



Physics 132

2nd Hour Exam
Time: 85:00 min

2nd Semester 2017/2018
Date: 13 /5/2018

Student Name:-----	Student NO-----
---------------------------	------------------------

✓	Sec	Instructor Name	Classes Time	✓	Sec	Instructor Name	Classes Time
○	1	Areej Abdel Rahman	S 9:00-9:50	○	8	Hazem Abu Sara	W 12:00-12:50
○	2	Hazem Abu Sara	M 12:00-12:50	○	9	Wael Karain	W 9:00-9:50
○	3	Areej Abdel Rahman	M 14:00-14:50	○	10	Abdallah Sayyed	W 14:00-14:50
○	4	Abdallah Sayyed	S 14:00-14:50	○	11	Abdallah Sayyed	W 11:00-11:50
○	5	Dua' Abu Mura	S 14:00-14:50	○	12	Areej Abdel Rahman	W 12:00-12:50
○	6	GHASSAN ABBAS	W 13:00-13:50	○			
○	7	Areej Abdel Rahman	M 15:00-15:50				

Answer Sheet:

Q#	a	b	c	d	e
1					
2					
3					
4					
5					
6					
7					
8					
9					
10					
11					
12					
13					
14					
15					
16					

Useful Formulae and Constants

1. $\epsilon_0 = 8.85 \times 10^{-12} \text{C}^2/\text{N}\cdot\text{m}^2$
2. $e = 1.6 \times 10^{-19} \text{C}$
3. $\mu_0 = 4\pi \times 10^{-7} \text{T}\cdot\text{m}/\text{A}$
4. $m_e = 9.11 \times 10^{-31} \text{Kg}$
5. $m_p = 1.67 \times 10^{-27} \text{Kg}$
6. $g = 10 \text{m}/\text{s}^2$
7. $\text{eV} = 1.6 \times 10^{-19} \text{J}$

Capacitance

1. $q = CV$
2. $C = \frac{\epsilon_0 A}{d}$
3. $\frac{1}{C_{eq}} = \sum \frac{1}{C_i}$ (Series connection)
4. $C_{eq} = \sum C_i$ (Parallel connection)
5. $U = \frac{q^2}{2C}$
6. $u = \frac{1}{2} \epsilon_0 E^2$
7. $\epsilon_0 \oint \kappa \vec{E} \cdot d\vec{A} = q$

Current and Resistance

8. $\vec{J} = ne\vec{v}_d$
9. $\vec{E} = \rho\vec{J}$
10. $R = \frac{\rho L}{A}$
11. $P = i^2 R$

Circuits

12. $\epsilon = \frac{dW}{dq}$
13. $V = \epsilon(1 - e^{-\frac{t}{RC}})$

Magnetic Fields

14. $\vec{F} = q\vec{v} \times \vec{B}$
15. $qvB = \frac{mv^2}{r}$
16. $f = \frac{qB}{2\pi m}$
17. $\vec{F} = i\vec{l} \times \vec{B}$
18. $\vec{\tau} = \vec{\mu} \times \vec{B}$
19. $U = -\vec{\mu} \cdot \vec{B}$
20. $W_a = U_f - U_i$

- 1- A potential difference of $300V$ is applied to a series connection of two capacitors of capacitance $C_1 = 3 \mu F$ and $C_2 = 6 \mu F$. What is the charge on C_1 ?
- a) $1200 \mu C$
 - b) $5400 \mu C$
 - c) $400 \mu C$
 - d) $200 \mu C$
 - e) $600 \mu C$ **
- 2- Two capacitors, $C_1 = 4 \mu F$ is charged so its charge is $q_1 = 80 \mu C$ and $C_2 = 6 \mu F$ is uncharged. The two capacitors are then connected in parallel. Find the charge on C_1 ?
- a) $80 \mu C$
 - b) $32 \mu C$ **
 - c) $48 \mu C$
 - d) $40 \mu C$
 - e) *zero*
- 3- A certain capacitor has a capacitance of C . After it is charged to a charge q and isolated, the two plates are brought closer together so its capacitance becomes $2C$. Find the work done by the agent?
- a) $-\frac{q^2}{2C}$
 - b) $\frac{q^2}{2C}$
 - c) $\frac{q^2}{C}$
 - d) $-\frac{q^2}{4C}$ **
 - e) $\frac{q^2}{4C}$

- 4- A slab of copper of thickness (b) is thrust into a parallel plate capacitor of plate area (A) and plate separation (d) as shown in the figure. What is the capacitance after the slab is introduced?

- a) $\frac{\epsilon_0 A}{d}$
 b) $\frac{\epsilon_0 A}{b}$
 c) $\frac{\epsilon_0 A}{d+b}$
 d) $\frac{\epsilon_0 A}{d-b}$ **
 e) 0

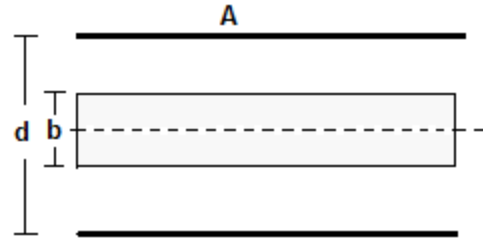

- 5- A isolated conducting sphere whose radius is R and has a charge Q . How much potential energy is stored in the electric field of this charged conductor?

- a) $\frac{kQ^2}{R}$
 b) $\frac{kQ^2}{2R}$ **
 c) $\frac{kQ}{R}$
 d) $\frac{kQ}{2R}$
 e) $\frac{kQ}{R^2}$

- 6- A certain wire has a resistance R . What is the resistance of a second wire, made of the same material, that is twice as long and has twice the radius?

- a) $2R$
 b) $4R$
 c) $R/2$ **
 d) $R/4$
 e) R

7- What is the current in a wire of radius (b) if the magnitude of the current density is variable and given by $J = ar$, in which a is constant and r is the radial distance?

- a) πba^3
- b) $2\pi ba^2$
- c) $\pi ba^3/3$
- d) $2\pi ba^3/3$
- e) $2\pi ab^3/3^{**}$

8- What is the value of 1 *Ampere.hour*?

- a) 3600 *Watt*
- b) 3600 *J*
- c) 3600 *C***
- d) 3600 *electrons*
- e) $1.6 \times 10^{-19} C$

9- In the circuit shown, the ideal batteries have *emfs*, $\varepsilon_1 = 20 V$, $\varepsilon_2 = 5 V$ and $R_1 = 3 \Omega$, $R_2 = 2 \Omega$. If the potential at a is $0 V$, what is the potential at b ?

- a) $+3 V$
- b) $+4 V$
- c) $-4 V$
- d) $-14 V^{**}$
- e) $+14 V$

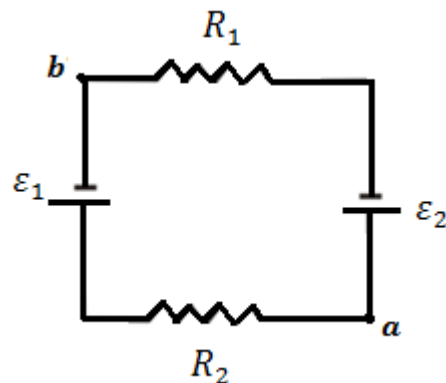

10- In the circuit shown find I_2 ?

- a) zero
- b) 3.5 A
- c) 7 A
- d) 2 A**
- e) 5 A

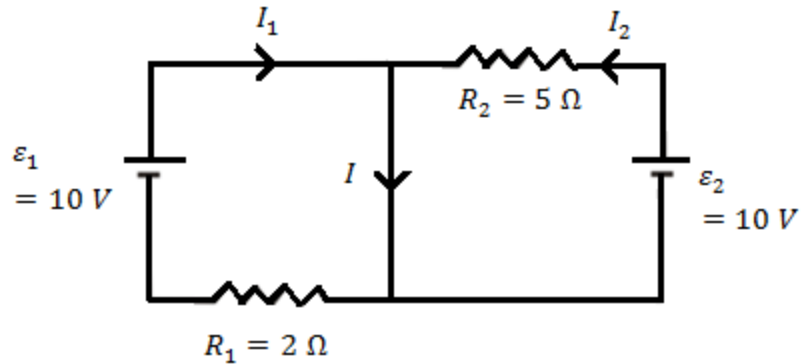

11- A capacitor with initial charge q_0 is discharged through a resistor. What is the time taken by the capacitor to lose two-thirds of its charge?

- a) 1.1τ **
- b) 0.41τ
- c) 0.693τ
- d) 0.18τ
- e) 0.48τ

12- In an RC series circuit, *emf* $\varepsilon = 10 V$, resistance $R = 2 M\Omega$, and capacitance $c = 2.5 \mu F$, the circuit closed at $t = 0$ to begin charging. Find the voltage across the capacitor at $t = 10 s$?

- a) 3.7 V
- b) 6.3 V
- c) 1.4 V
- d) 8.6 V**
- e) 9.5 V

13- At one instant, $\vec{v} = (200\hat{i} + 300\hat{j}) \text{ m/s}$ is the velocity of an electron in a uniform magnetic field $\vec{B} = (0.05\hat{i} - 0.15\hat{j}) \text{ T}$. At that instant find the force on the electron?

- a) $+72 \times 10^{-19} \hat{k} \text{ N}^{**}$
- b) $-72 \times 10^{-19} \hat{k} \text{ N}$
- c) $-45 \times 10^{-19} \hat{k} \text{ N}$
- d) $+88 \times 10^{-19} \hat{j} \text{ N}$
- e) $+88 \times 10^{-19} \hat{i} \text{ N}$

14- An electron moves with speed v into a region of uniform magnetic field B . The angle between them is $= 65^\circ$. Describe the motion of the electron and find the periodic time?

- a) Uniform circular motion, $T = \frac{2\pi m}{eB}$
- b) Nonuniform circular motion, $T = \frac{2\pi m}{eB} \cos 65$
- c) Helical motion, $T = \frac{2\pi m}{eB}^{**}$
- d) Helical motion, $T = \frac{2\pi m}{eB} \cos 65$
- e) Helical motion, $T = \frac{2\pi m}{eB} \sin 65$

15- The coil in the figure, which is parallel to the xz – plane, carries current $I = 2 \text{ A}$ in the direction indicated, has 3 turns and area of $4 \times 10^{-3} \text{ m}^2$, and lies in a uniform magnetic field $\vec{B} = (2\hat{i} - 4\hat{j} - 3\hat{k}) \text{ mT}$. What is the potential energy of the coil in the magnetic field?

- a) $-48 \mu\text{J}$
- b) $+24 \mu\text{J}$
- c) $+96 \mu\text{J}^{**}$
- d) $+72 \mu\text{J}$
- e) zero

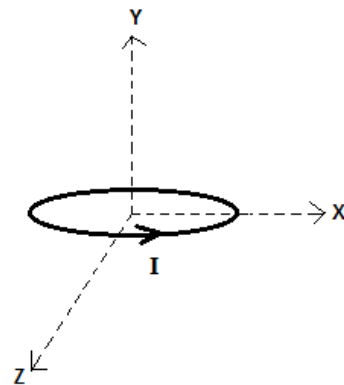

16- A magnetic field CAN:

- a) Exert a force on a charge at rest
- b) Accelerate a charge moving parallel to the field
- c) Change the momentum of a charge **
- d) Change the kinetic energy of a charge
- e) Not exist