

Chapter 5: FORCE AND MOTION — I

- An example of an inertial reference frame is:
 - any reference frame that is not accelerating
 - a frame attached to a particle on which there are no forces
 - any reference frame that is at rest
 - a reference frame attached to the center of the universe
 - a reference frame attached to Earthans: B
- An object moving at constant velocity in an inertial frame must:
 - have a net force on it
 - eventually stop due to gravity
 - not have any force of gravity on it
 - have zero net force on it
 - have no frictional force on itans: D
- In SI units a force is numerically equal to the _____, when the force is applied to it.
 - velocity of the standard kilogram
 - speed of the standard kilogram
 - velocity of any object
 - acceleration of the standard kilogram
 - acceleration of any objectans: D
- Which of the following quantities is NOT a vector?
 - Mass
 - Displacement
 - Weight
 - Acceleration
 - Forceans: A
- A newton is the force:
 - of gravity on a 1 kg body
 - of gravity on a 1 g body
 - that gives a 1 g body an acceleration of 1 cm/s^2
 - that gives a 1 kg body an acceleration of 1 m/s^2
 - that gives a 1 kg body an acceleration of 9.8 m/s^2ans: D

6. The unit of force called the newton is:
- A. $9.8 \text{ kg} \cdot \text{m}/\text{s}^2$
 - B. $1 \text{ kg} \cdot \text{m}/\text{s}^2$
 - C. defined by means of Newton's third law
 - D. 1 kg of mass
 - E. 1 kg of force

ans: B

7. A force of 1 N is:

- A. $1 \text{ kg}/\text{s}$
- B. $1 \text{ kg} \cdot \text{m}/\text{s}$
- C. $1 \text{ kg} \cdot \text{m}/\text{s}^2$
- D. $1 \text{ kg} \cdot \text{m}^2/\text{s}$
- E. $1 \text{ kg} \cdot \text{m}^2/\text{s}^2$

ans: C

8. The standard 1-kg mass is attached to a compressed spring and the spring is released. If the mass initially has an acceleration of $5.6 \text{ m}/\text{s}^2$, the force of the spring has a magnitude of:

- A. 2.8 N
- B. 5.6 N
- C. 11.2 N
- D. 0
- E. an undetermined amount

ans: B

9. Acceleration is always in the direction:

- A. of the displacement
- B. of the initial velocity
- C. of the final velocity
- D. of the net force
- E. opposite to the frictional force

ans: D

10. The term "mass" refers to the same physical concept as:

- A. weight
- B. inertia
- C. force
- D. acceleration
- C. volume

ans: B

11. The inertia of a body tends to cause the body to:
- A. speed up
 - B. slow down
 - C. resist any change in its motion
 - D. fall toward Earth
 - E. decelerate due to friction

ans: C

12. A heavy ball is suspended as shown. A quick jerk on the lower string will break that string but a slow pull on the lower string will break the upper string. The first result occurs because:

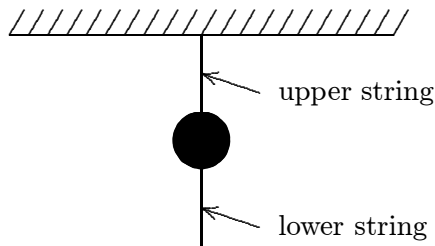

- A. the force is too small to move the ball
- B. action and reaction is operating
- C. the ball has inertia
- D. air friction holds the ball back
- E. the ball has too much energy

ans: C

13. When a certain force is applied to the standard kilogram its acceleration is 5.0 m/s^2 . When the same force is applied to another object its acceleration is one-fifth as much. The mass of the object is:

- A. 0.2 kg
- B. 0.5 kg
- C. 1.0 kg
- D. 5.0 kg
- E. 10 kg

ans: D

14. Mass differs from weight in that:

- A. all objects have weight but some lack mass
- B. weight is a force and mass is not
- C. the mass of an object is always more than its weight
- D. mass can be expressed only in the metric system
- E. there is no difference

ans: B

15. The mass of a body:
- A. is slightly different at different places on Earth
 - B. is a vector
 - C. is independent of the free-fall acceleration
 - D. is the same for all bodies of the same volume
 - E. can be measured most accurately on a spring scale
- ans: C
16. The mass and weight of a body:
- A. differ by a factor of 9.8
 - B. are identical
 - C. are the same physical quantities expressed in different units
 - D. are both a direct measure of the inertia of the body
 - E. have the same ratio as that of any other body placed at that location
- ans: E
17. An object placed on an equal-arm balance requires 12 kg to balance it. When placed on a spring scale, the scale reads 12 kg. Everything (balance, scale, set of weights and object) is now transported to the Moon where the free-fall acceleration is one-sixth that on Earth. The new readings of the balance and spring scale (respectively) are:
- A. 12 kg, 12 kg
 - B. 2 kg, 2 kg
 - C. 12 kg, 2 kg
 - D. 2 kg, 12 kg
 - E. 12 kg, 72 kg
- ans: C
18. Two objects, one having three times the mass of the other, are dropped from the same height in a vacuum. At the end of their fall, their velocities are equal because:
- A. anything falling in vacuum has constant velocity
 - B. all objects reach the same terminal velocity
 - C. the acceleration of the larger object is three times greater than that of the smaller object
 - D. the force of gravity is the same for both objects
 - E. none of the above
- ans: E
19. A feather and a lead ball are dropped from rest in vacuum on the Moon. The acceleration of the feather is:
- A. more than that of the lead ball
 - B. the same as that of the lead ball
 - C. less than that of the lead ball
 - D. 9.8 m/s^2
 - E. zero since it floats in a vacuum
- ans: B

20. The block shown moves with constant velocity on a horizontal surface. Two of the forces on it are shown. A frictional force exerted by the surface is the only other horizontal force on the block. The frictional force is:

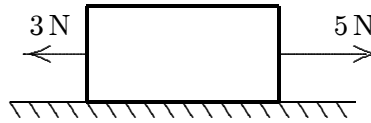

- A. 0
- B. 2 N, leftward
- C. 2 N, rightward
- D. slightly more than 2 N, leftward
- E. slightly less than 2 N, leftward

ans: B

21. Two forces, one with a magnitude of 3 N and the other with a magnitude of 5 N, are applied to an object. For which orientations of the forces shown in the diagrams is the magnitude of the acceleration of the object the least?

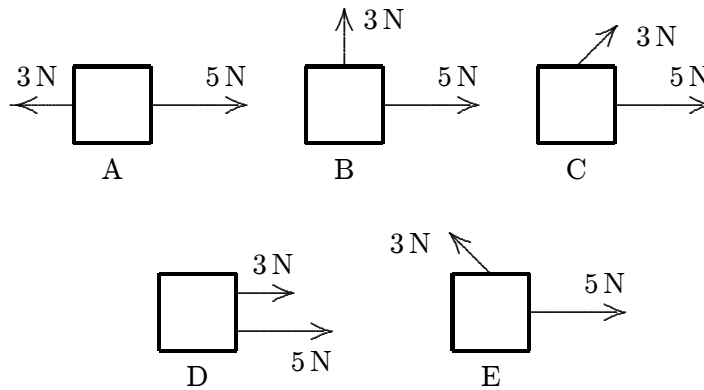

ans: A

22. A crate rests on a horizontal surface and a woman pulls on it with a 10-N force. Rank the situations shown below according to the magnitude of the normal force exerted by the surface on the crate, least to greatest.

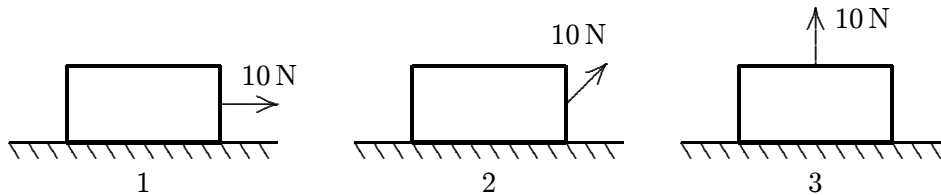

- A. 1, 2, 3
- B. 2, 1, 3
- C. 2, 3, 1
- D. 1, 3, 2
- E. 3, 2, 1

ans: E

23. A heavy wooden block is dragged by a force \vec{F} along a rough steel plate, as shown in the diagrams for two cases. The magnitude of the applied force \vec{F} is the same for both cases. The normal force in (ii), as compared with the normal force in (i) is:

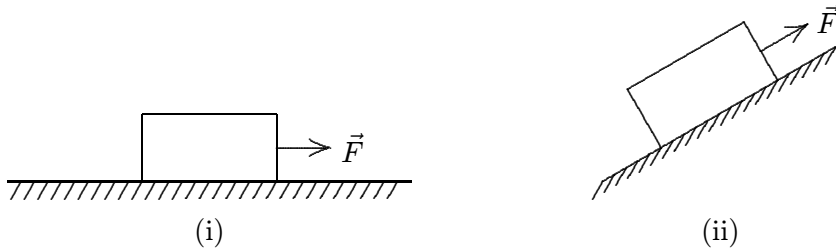

- A. the same
 B. greater
 C. less
 D. less for some angles of the incline and greater for others
 E. less or greater, depending on the magnitude of the applied force \vec{F} .
- ans: C
24. Equal forces \vec{F} act on isolated bodies A and B. The mass of B is three times that of A. The magnitude of the acceleration of A is:
- A. three times that of B
 B. 1/3 that of B
 C. the same as B
 D. nine times that of B
 E. 1/9 that of B
- ans: A
25. A car travels east at constant velocity. The net force on the car is:
- A. east
 B. west
 C. up
 D. down
 E. zero
- ans: E
26. A constant force of 8.0 N is exerted for 4.0 s on a 16-kg object initially at rest. The change in speed of this object will be:
- A. 0.5 m/s
 B. 2 m/s
 C. 4 m/s
 D. 8 m/s
 E. 32 m/s
- ans: B

27. A 6-kg object is moving south. A net force of 12 N north on it results in the object having an acceleration of:
- A. 2 m/s^2 , north
 - B. 2 m/s^2 , south
 - C. 6 m/s^2 , north
 - D. 18 m/s^2 , north
 - E. 18 m/s^2 , south
- ans: A
28. A 9000-N automobile is pushed along a level road by four students who apply a total forward force of 500 N. Neglecting friction, the acceleration of the automobile is:
- A. 0.055 m/s^2
 - B. 0.54 m/s^2
 - C. 1.8 m/s^2
 - D. 9.8 m/s^2
 - E. 18 m/s^2
- ans: B
29. An object rests on a horizontal frictionless surface. A horizontal force of magnitude F is applied. This force produces an acceleration:
- A. only if F is larger than the weight of the object
 - B. only while the object suddenly changes from rest to motion
 - C. always
 - D. only if the inertia of the object decreases
 - E. only if F is increasing
- ans: C
30. A 25-kg crate is pushed across a frictionless horizontal floor with a force of 20 N, directed 20° below the horizontal. The acceleration of the crate is:
- A. 0.27 m/s^2
 - B. 0.75 m/s^2
 - C. 0.80 m/s^2
 - D. 170 m/s^2
 - E. 470 m/s^2
- ans: B
31. A ball with a weight of 1.5 N is thrown at an angle of 30° above the horizontal with an initial speed of 12 m/s. At its highest point, the net force on the ball is:
- A. 9.8 N, 30° below horizontal
 - B. zero
 - C. 9.8 N, up
 - D. 9.8 N, down
 - E. 1.5 N, down
- ans: E

32. Two forces are applied to a 5.0-kg crate; one is 6.0 N to the north and the other is 8.0 N to the west. The magnitude of the acceleration of the crate is:
- A. 0.50 m/s^2
 - B. 2.0 m/s^2
 - C. 2.8 m/s^2
 - D. 10 m/s^2
 - E. 50 m/s^2
- ans: B

33. A 400-N steel ball is suspended by a light rope from the ceiling. The tension in the rope is:
- A. 400 N
 - B. 800 N
 - C. zero
 - D. 200 N
 - E. 560 N
- ans: A

34. A heavy steel ball B is suspended by a cord from a block of wood W. The entire system is dropped through the air. Neglecting air resistance, the tension in the cord is:
- A. zero
 - B. the difference in the masses of B and W
 - C. the difference in the weights of B and W
 - D. the weight of B
 - E. none of these
- ans: A

35. A circus performer of weight W is walking along a “high wire” as shown. The tension in the wire:

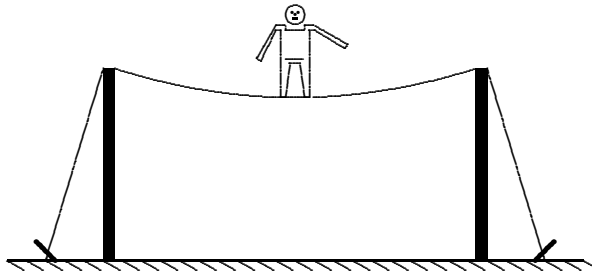

- A. is approximately W
 - B. is approximately $W/2$
 - C. is much less than W
 - D. is much more than W
 - E. depends on whether he stands on one foot or two feet
- ans: D

36. A 1000-kg elevator is rising and its speed is increasing at 3 m/s^2 . The tension force of the cable on the elevator is:
- A. 6800 N
 - B. 1000 N
 - C. 3000 N
 - D. 9800 N
 - E. 12800 N
- ans: E

- *37. A 5-kg block is suspended by a rope from the ceiling of an elevator as the elevator accelerates downward at 3.0 m/s^2 . The tension force of the rope on the block is:
- A. 15 N, up
 - B. 34 N, up
 - C. 34 N, down
 - D. 64 N, up
 - E. 64 N, down
- ans: B

38. A crane operator lowers a 16,000-N steel ball with a downward acceleration of 3 m/s^2 . The tension force of the cable is:
- A. 4900 N
 - B. 11,000 N
 - C. 16,000 N
 - D. 21,000 N
 - E. 48,000 N
- ans: B

39. A 1-N pendulum bob is held at an angle θ from the vertical by a 2-N horizontal force F as shown. The tension in the string supporting the pendulum bob (in newtons) is:

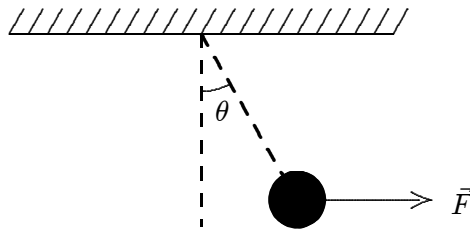

- A. $\cos \theta$
 - B. $2/\cos \theta$
 - C. $\sqrt{5}$
 - D. 1
 - E. none of these
- ans: C

40. A car moves horizontally with a constant acceleration of 3 m/s^2 . A ball is suspended by a string from the ceiling of the car. The ball does not swing, being at rest with respect to the car. What angle does the string make with the vertical?
- A. 17°
 - B. 35°
 - C. 52°
 - D. 73°
 - E. Cannot be found without knowing the length of the string

ans: A

41. A man weighing 700 N is in an elevator that is accelerating upward at 4 m/s^2 . The force exerted on him by the elevator floor is:
- A. 71 N
 - B. 290 N
 - C. 410 N
 - D. 700 N
 - E. 990 N

ans: E

42. You stand on a spring scale on the floor of an elevator. Of the following, the scale shows the highest reading when the elevator:
- A. moves upward with increasing speed
 - B. moves upward with decreasing speed
 - C. remains stationary
 - D. moves downward with increasing speed
 - E. moves downward at constant speed

ans: A

43. You stand on a spring scale on the floor of an elevator. Of the following, the scale shows the highest reading when the elevator:
- A. moves downward with increasing speed
 - B. moves downward with decreasing speed
 - C. remains stationary
 - D. moves upward with decreasing speed
 - E. moves upward at constant speed

ans: B

44. When a 25-kg crate is pushed across a frictionless horizontal floor with a force of 200 N , directed 20° below the horizontal, the magnitude of the normal force of the floor on the crate is:
- A. 25 N
 - B. 68 N
 - C. 180 N
 - D. 250 N
 - E. 310 N

ans: E

45. A block slides down a frictionless plane that makes an angle of 30° with the horizontal. The acceleration of the block is:
- A. 980 cm/s^2
 - B. 566 cm/s^2
 - C. 849 cm/s^2
 - D. zero
 - E. 490 cm/s^2
- ans: E
46. A 25-N crate slides down a frictionless incline that is 25° above the horizontal. The magnitude of the normal force of the incline on the crate is:
- A. 11 N
 - B. 23 N
 - C. 25 N
 - D. 100 N
 - E. 220 N
- ans: B
47. A 25-N crate is held at rest on a frictionless incline by a force that is parallel to the incline. If the incline is 25° above the horizontal the magnitude of the applied force is:
- A. 4.1 N
 - B. 4.6 N
 - C. 8.9 N
 - D. 11 N
 - E. 23 N
- ans: D
48. A 25-N crate is held at rest on a frictionless incline by a force that is parallel to the incline. If the incline is 25° above the horizontal the magnitude of the normal force of the incline on the crate is:
- A. 4.1 N
 - B. 4.6 N
 - C. 8.9 N
 - D. 11 N
 - E. 23 N
- ans: E
49. A 32-N force, parallel to the incline, is required to push a certain crate at constant velocity up a frictionless incline that is 30° above the horizontal. The mass of the crate is:
- A. 3.3 kg
 - B. 3.8 kg
 - C. 5.7 kg
 - D. 6.5 kg
 - E. 160 kg
- ans: D

50. A sled is on an icy (frictionless) slope that is 30° above the horizontal. When a 40-N force, parallel to the incline and directed up the incline, is applied to the sled, the acceleration of the sled is 2.0 m/s^2 , down the incline. The mass of the sled is:
- A. 3.8 kg
 - B. 4.1 kg
 - C. 5.8 kg
 - D. 6.2 kg
 - E. 10 kg
- ans: E
51. When a 40-N force, parallel to the incline and directed up the incline, is applied to a crate on a frictionless incline that is 30° above the horizontal, the acceleration of the crate is 2.0 m/s^2 , up the incline. The mass of the crate is:
- A. 3.8 kg
 - B. 4.1 kg
 - C. 5.8 kg
 - D. 6.2 kg
 - E. 10 kg
- ans: C
52. The “reaction” force does not cancel the “action” force because:
- A. the action force is greater than the reaction force
 - B. they are on different bodies
 - C. they are in the same direction
 - D. the reaction force exists only after the action force is removed
 - E. the reaction force is greater than the action force
- ans: B
53. A book rests on a table, exerting a downward force on the table. The reaction to this force is:
- A. the force of Earth on the book
 - B. the force of the table on the book
 - C. the force of Earth on the table
 - D. the force of the book on Earth
 - E. the inertia of the book
- ans: B
54. A lead block is suspended from your hand by a string. The reaction to the force of gravity on the block is the force exerted by:
- A. the string on the block
 - B. the block on the string
 - C. the string on the hand
 - D. the hand on the string
 - E. the block on Earth
- ans: E

55. A 5-kg concrete block is lowered with a downward acceleration of 2.8 m/s^2 by means of a rope. The force of the block on the rope is:
- A. 14 N, up
 - B. 14 N, down
 - C. 35 N, up
 - D. 35 N, down
 - E. 49 N, up
- ans: D
56. A 90-kg man stands in an elevator that is moving up at a constant speed of 5.0 m/s . The force exerted by him on the floor is about:
- A. zero
 - B. 90 N
 - C. 880 N
 - D. 450 N
 - E. 49 N
- ans: C
57. A 90-kg man stands in an elevator that has a downward acceleration of 1.4 m/s^2 . The force exerted by him on the floor is about:
- A. zero
 - B. 90 N
 - C. 760 N
 - D. 880 N
 - E. 1010 N
- ans: C
58. A 5-kg concrete block is lowered with a downward acceleration of 2.8 m/s^2 by means of a rope. The force of the block on Earth is:
- A. 14 N, up
 - B. 14 N, down
 - C. 35 N, up
 - D. 35 N, down
 - E. 49 N, up
- ans: E

59. Two blocks are connected by a string and pulley as shown. Assuming that the string and pulley are massless, the magnitude of the acceleration of each block is:

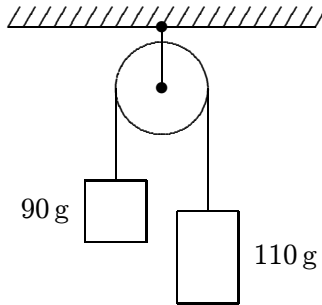

- A. 0.049 m/s^2
- B. 0.020 m/s^2
- C. 0.0098 m/s^2
- D. 0.54 m/s^2
- E. 0.98 m/s^2

ans: E

60. A 70-N block and a 35-N block are connected by a string as shown. If the pulley is massless and the surface is frictionless, the magnitude of the acceleration of the 35-N block is:

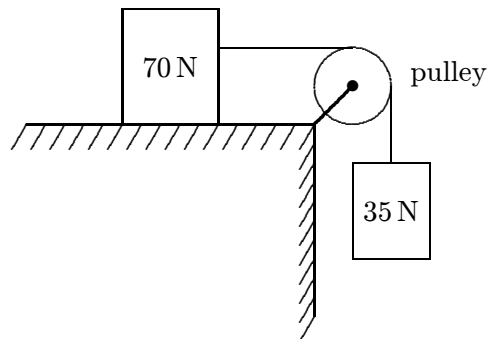

- A. 1.6 m/s^2
- B. 3.3 m/s^2
- C. 4.9 m/s^2
- D. 6.7 m/s^2
- E. 9.8 m/s^2

ans: B

61. A 13-N weight and a 12-N weight are connected by a massless string over a massless, frictionless pulley. The 13-N weight has a downward acceleration with magnitude equal to that of a freely falling body times:

A. 1
B. $1/12$
C. $1/13$
D. $1/25$
E. $13/25$

ans: D

62. A massless rope passes over a massless pulley suspended from the ceiling. A 4-kg block is attached to one end and a 5-kg block is attached to the other end. The acceleration of the 5-kg block is:

A. $g/4$
B. $5g/9$
C. $4g/9$
D. $g/5$
E. $g/9$

ans: E

63. Two blocks, weighing 250 N and 350 N, respectively, are connected by a string that passes over a massless pulley as shown. The tension in the string is:

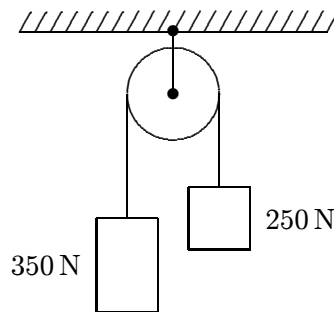

A. 210 N
B. 290 N
C. 410 N
D. 500 N
E. 4900 N

ans: B

64. Three books (X, Y, and Z) rest on a table. The weight of each book is indicated. The net force acting on book Y is:

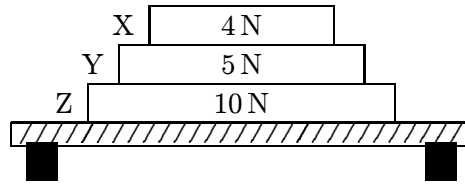

- A. 4 N down
- B. 5 N up
- C. 9 N down
- D. zero
- E. none of these

ans: D

65. Three books (X, Y, and Z) rest on a table. The weight of each book is indicated. The force of book Z on book Y is:

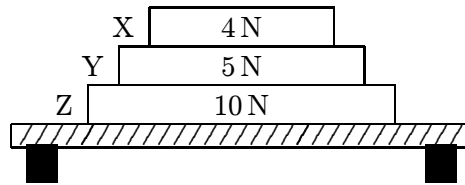

- A. 0
- B. 5 N
- C. 9 N
- D. 14 N
- E. 19 N

ans: C

66. Three blocks (A,B,C), each having mass M , are connected by strings as shown. Block C is pulled to the right by a force \vec{F} that causes the entire system to accelerate. Neglecting friction, the net force acting on block B is:

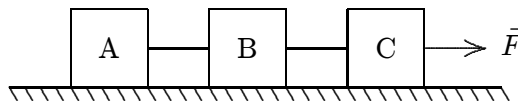

- A. zero
- B. $\vec{F}/3$
- C. $\vec{F}/2$
- D. $2\vec{F}/3$
- E. \vec{F}

ans: B

67. Two blocks with masses m and M are pushed along a horizontal frictionless surface by a horizontal applied force \vec{F} as shown. The magnitude of the force of either of these blocks on the other is:

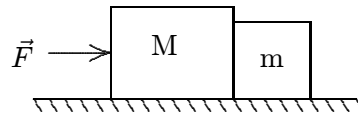

- A. $mF/(m + M)$
- B. mF/M
- C. $mF/(M - m)$
- D. $MF/(M + m)$
- E. MF/m

ans: A

68. Two blocks (A and B) are in contact on a horizontal frictionless surface. A 36-N constant force is applied to A as shown. The magnitude of the force of A on B is:

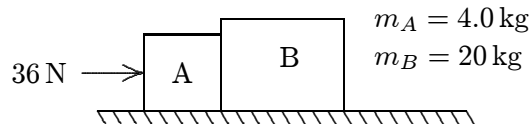

- A. 1.5 N
- B. 6.0 N
- C. 29 N
- D. 30 N
- E. 36 N

ans: D

69. A short 10-g string is used to pull a 50-g toy across a frictionless horizontal surface. If a 3.0×10^{-2} -N force is applied horizontally to the free end, the force of the string on the toy, at the other end, is:

- A. 0.15 N
- B. 6.0×10^{-3} N
- C. 2.5×10^{-2} N
- D. 3.0×10^{-2} N
- E. 3.5×10^{-2} N

ans: C