

Chapter 30: INDUCTION AND INDUCTANCE

1. The normal to a certain 1-m^2 area makes an angle of 60° with a uniform magnetic field. The magnetic flux through this area is the same as the flux through a second area that is perpendicular to the field if the second area is:
- A. 0.866 m^2
 - B. 1.15 m^2
 - C. 0.5 m^2
 - D. 2 m^2
 - E. 1 m^2

ans: C

2. Suppose this page is perpendicular to a uniform magnetic field and the magnetic flux through it is 5 Wb . If the page is turned by 30° around an edge the flux through it will be:
- A. 2.5 Wb
 - B. 4.3 Wb
 - C. 5 Wb
 - D. 5.8 Wb
 - E. 10 Wb

ans: B

3. A 2-T uniform magnetic field makes an angle of 30° with the z axis. The magnetic flux through a 3-m^2 portion of the xy plane is:
- A. 2.0 Wb
 - B. 3.0 Wb
 - C. 5.2 Wb
 - D. 6.0 Wb
 - E. 12 Wb

ans: C

4. A uniform magnetic field makes an angle of 30° with the z axis. If the magnetic flux through a 1-m^2 portion of the xy plane is 5 Wb then the magnetic flux through a 2-m^2 portion of the same plane is:
- A. 2.5 Wb
 - B. 4.3 Wb
 - C. 5 Wb
 - D. 5.8 Wb
 - E. 10 Wb

ans: E

5. 1 weber is the same as:
- A. 1 V/s
 - B. 1 T/s
 - C. 1 T/m
 - D. $1\text{ T}\cdot\text{m}^2$
 - E. 1 T/m^2

ans: D

6. 1 weber is the same as:

- A. $1 \text{ V} \cdot \text{s}$
- B. $1 \text{ T} \cdot \text{s}$
- C. 1 T/m
- D. 1 V/s
- E. 1 T/m^2

ans: A

7. The units of motional emf are:

- A. volt/second
- B. volt·meter/second
- C. volt/tesla
- D. tesla/second
- E. tesla·meter²/second

ans: E

8. Faraday's law states that an induced emf is proportional to:

- A. the rate of change of the magnetic field
- B. the rate of change of the electric field
- C. the rate of change of the magnetic flux
- D. the rate of change of the electric flux
- E. zero

ans: C

9. The emf that appears in Faraday's law is:

- A. around a conducting circuit
- B. around the boundary of the surface used to compute the magnetic flux
- C. throughout the surface used to compute the magnetic flux
- D. perpendicular to the surface used to compute the magnetic flux
- E. none of the above

ans: B

10. If the magnetic flux through a certain region is changing with time:

- A. energy must be dissipated as heat
- B. an electric field must exist at the boundary
- C. a current must flow around the boundary
- D. an emf must exist around the boundary
- E. a magnetic field must exist at the boundary

ans: D

11. A square loop of wire lies in the plane of the page. A decreasing magnetic field is directed into the page. The induced current in the loop is:
- counterclockwise
 - clockwise
 - zero
 - up the left edge and from right to left along the top edge
 - through the middle of the page

ans: B

12. As an externally generated magnetic field through a certain conducting loop increases in magnitude, the field produced at points inside the loop by the current induced in the loop must be:
- increasing in magnitude
 - decreasing in magnitude
 - in the same direction as the applied field
 - directed opposite to the applied field
 - perpendicular to the applied field

ans: D

13. At any instant of time the total magnetic flux through a stationary conducting loop is less in magnitude than the flux associated with an externally applied field. This might occur because:
- the applied field is normal to the loop and increasing in magnitude
 - the applied field is normal to the loop and decreasing in magnitude
 - the applied field is parallel to the plane of the loop and increasing in magnitude
 - the applied field is parallel to the plane of the loop and decreasing in magnitude
 - the applied field is tangent to the loop

ans: A

14. A long straight wire is in the plane of a rectangular conducting loop. The straight wire carries a constant current i , as shown. While the wire is being moved toward the rectangle the current in the rectangle is:

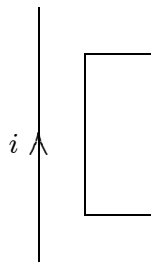

- zero
- clockwise
- counterclockwise
- clockwise in the left side and counterclockwise in the right side
- counterclockwise in the left side and clockwise in the right side

ans: C

15. A long straight wire is in the plane of a rectangular conducting loop. The straight wire carries an increasing current in the direction shown. The current in the rectangle is:

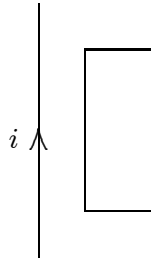

- A. zero
- B. clockwise
- C. counterclockwise
- D. clockwise in the left side and counterclockwise in the right side
- E. counterclockwise in the left side and clockwise in the right side

ans: C

16. A long straight wire is in the plane of a rectangular conducting loop. The straight wire initially carries a constant current i in the direction shown. While the current i is being shut off, the current in the rectangle is:

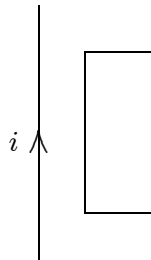

- A. zero
- B. clockwise
- C. counterclockwise
- D. clockwise in the left side and counterclockwise in the right side
- E. counterclockwise in the left side and clockwise in the right side

ans: B

17. A rectangular loop of wire is placed midway between two long straight parallel conductors as shown. The conductors carry currents i_1 and i_2 , as indicated. If i_1 is increasing and i_2 is constant, then the induced current in the loop is:

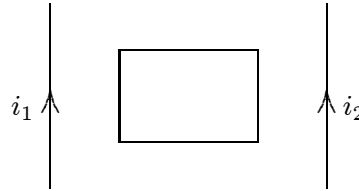

- A. zero
 B. clockwise
 C. counterclockwise
 D. depends on $i_1 - i_2$
 E. depends on $i_1 + i_2$
 ans: C
18. You push a permanent magnet with its north pole away from you toward a loop of conducting wire in front of you. Before the north pole enters the loop the current in the loop is:
 A. zero
 B. clockwise
 C. counterclockwise
 D. to your left
 E. to your right
 ans: C
19. A vertical bar magnet is dropped through the center of a horizontal loop of wire, with its north pole leading. At the instant when the midpoint of the magnet is in the plane of the loop, the induced current at point P, viewed from above, is:
 A. maximum and clockwise
 B. maximum and counterclockwise
 C. not maximum but clockwise
 D. not maximum but counterclockwise
 E. essentially zero
 ans: E
20. A circular loop of wire rotates about a diameter in a magnetic field that is perpendicular to the axis of rotation. Looking in the direction of the field at the loop the induced current is:
 A. always clockwise
 B. always counterclockwise
 C. clockwise in the lower half of the loop and counterclockwise in the upper half
 D. clockwise in the upper half of the loop and counterclockwise in the lower half
 E. sometimes clockwise and sometimes counterclockwise
 ans: E

21. In the experiment shown:

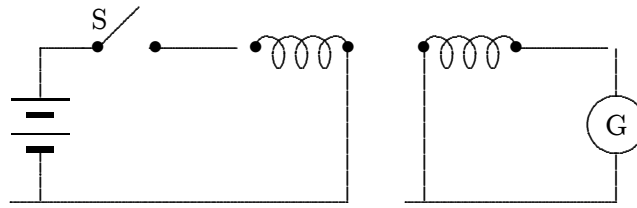

- A. there is a steady reading in G as long as S is closed
- B. a motional emf is generated when S is closed
- C. the current in the battery goes through G
- D. there is a current in G just after S is opened or closed
- E. since the two loops are not connected, the current in G is always zero

ans: D

22. The emf developed in a coil X due to the current in a neighboring coil Y is proportional to the:

- A. magnetic field in X
- B. rate of change of magnetic field in X
- C. resistance of X
- D. thickness of the wire in X
- E. current in Y

ans: B

23. One hundred turns of insulated copper wire are wrapped around an iron core of cross-sectional area 0.100m^2 . The circuit is completed by connecting the coil to a $10\text{-}\Omega$ resistor. As the magnetic field along the coil axis changes from 1.00 T in one direction to 1.00 T in the other direction, the total charge that flows through the resistor is:

- A. 10^{-2} C
- B. $2 \times 10^{-2}\text{ C}$
- C. 1 C
- D. 2 C
- E. 0.20 C

ans: D

24. In the circuit shown, there will be a non-zero reading in galvanometer G:

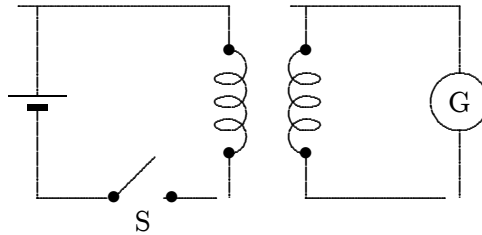

- A. only just after S is closed
- B. only just after S is opened
- C. only while S is kept closed
- D. never
- E. only just after S is opened or closed

ans: E

25. A magnet moves inside a coil. Consider the following factors:

- I. strength of the magnet
- II. number of turns in the coil
- III. speed at which the magnet moves

Which can affect the emf induced in the coil?

- A. I only
- B. II only
- C. III only
- D. I and II only
- E. I, II, III

ans: E

26. The graph shows the magnitude B of a uniform magnetic field that is perpendicular to the plane of a conducting loop. Rank the five regions indicated on the graph according to the magnitude of the emf induced in the loop, from least to greatest.

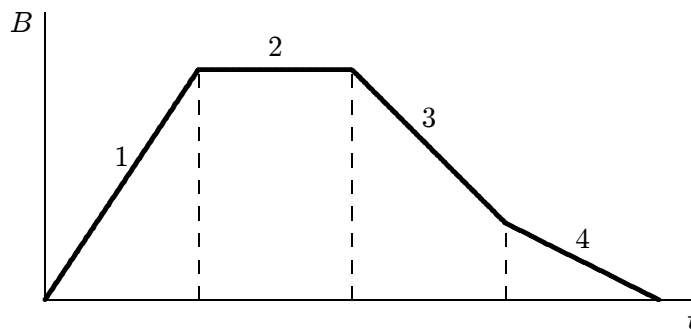

- A. 1, 2, 3, 4
- B. 2, 4, 3, 1
- C. 4, 3, 1, 2
- D. 1, 3, 4, 2
- E. 4, 3, 2, 1

ans: B

27. The circuit shown is in a uniform magnetic field that is into the page. The current in the circuit is 0.20 A. At what rate is the magnitude of the magnetic field changing? Is it increasing or decreasing?:

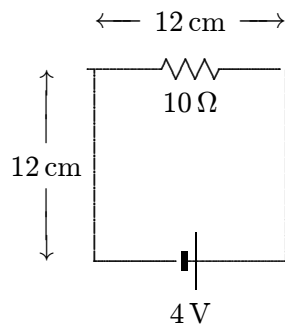

- A. zero
 B. 140 T/s, decreasing
 C. 140 T/s, increasing
 D. 420 T/s, decreasing
 E. 420 T/s, increasing
- ans: B
28. A changing magnetic field pierces the interior of a circuit containing three identical resistors. Two voltmeters are connected to the same points, as shown. V_1 reads 1 mV. V_2 reads:

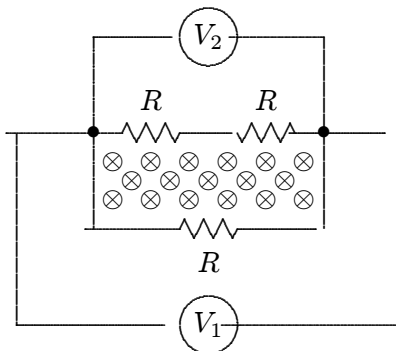

- A. 0
 B. $1/3$ mV
 C. $1/2$ mV
 D. 1 mV
 E. 2 mV
- ans: E

29. A circular loop of wire is positioned half in and half out of a square region of constant uniform magnetic field directed into the page, as shown. To induce a clockwise current in this loop:

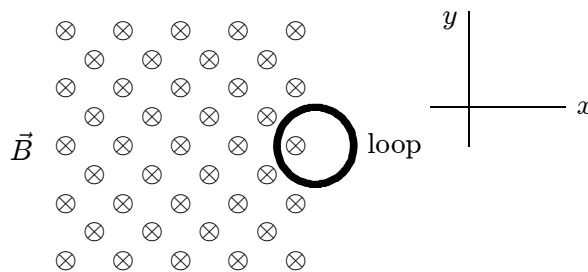

- A. move it in $+x$ direction
- B. move it in $+y$ direction
- C. move it in $-y$ direction
- D. move it in $-x$ direction
- E. increase the strength of the magnetic field

ans: A

30. The four wire loops shown have edge lengths of either L , $2L$, or $3L$. They will move with the same speed into a region of uniform magnetic field \vec{B} , directed out of the page. Rank them according to the maximum magnitude of the induced emf, least to greatest.

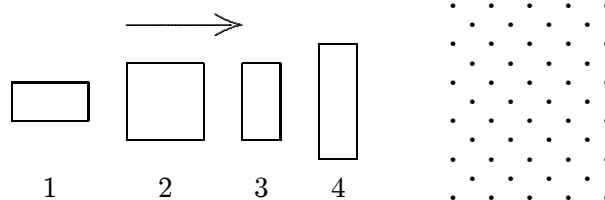

- A. 1 and 2 tie, then 3 and 4 tie
- B. 3 and 4 tie, then 1 and 2 tie
- C. 4, 2, 3, 1
- D. 1, then 2 and 3 tie, then 4
- E. 1, 2, 3, 4

ans: D

31. A square loop of wire moves with a constant speed v from a field-free region into a region of constant uniform magnetic field, as shown. Which of the five graphs correctly shows the induced current i in the loop as a function of time t ?

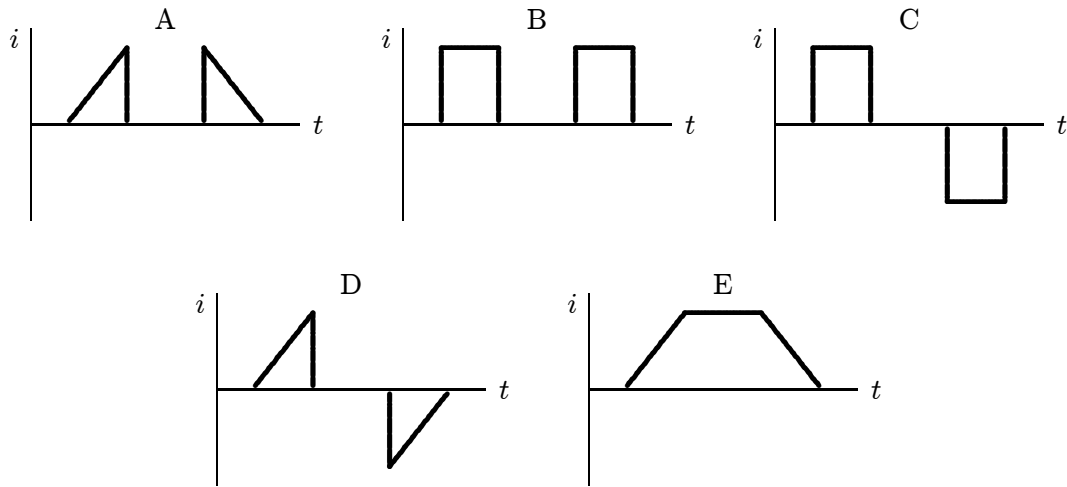
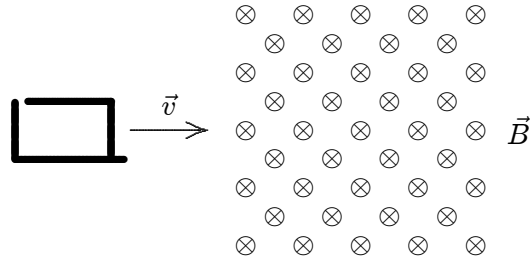

ans: C

32. The figure shows a bar moving to the right on two conducting rails. To make an induced current i in the direction indicated, a constant magnetic field in region A should be in what direction?

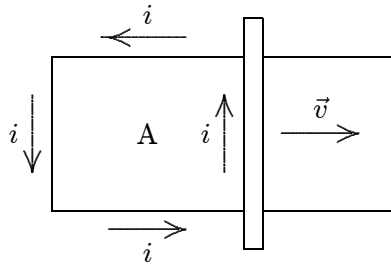

- A. Right
- B. Left
- C. Into the page
- D. Out of the page
- E. Impossible; this cannot be done with a constant magnetic field

ans: C

33. A car travels northward at 75 km/h along a straight road in a region where Earth's magnetic field has a vertical component of 0.50×10^{-4} T. The emf induced between the left and right side, separated by 1.7 m, is:
- A. 0
 - B. 1.8 mV
 - C. 3.6 mV
 - D. 6.4 mV
 - E. 13 mV
- ans: B

34. Coils P and Q each have a large number of turns of insulated wire. When switch S is closed, the pointer of galvanometer G is deflected toward the left. With S now closed, to make the pointer of G deflect toward the right one could:

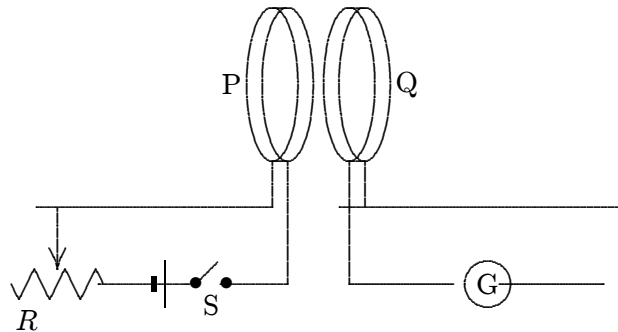

- A. move the slide of the rheostat R quickly to the right
 - B. move coil P toward coil Q
 - C. move coil Q toward coil P
 - D. open S
 - E. do none of the above
- ans: D
35. A rod lies across frictionless rails in a constant uniform magnetic field \vec{B} , as shown. The rod moves to the right with speed v . In order for the emf around the circuit to be zero, the magnitude of the magnetic field should:

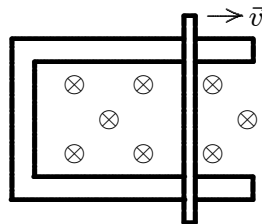

- A. not change
 - B. increase linearly with time
 - C. decrease linearly with time
 - D. increase quadratically with time
 - E. decrease quadratically with time
- ans: C

36. A rectangular loop of wire has area A . It is placed perpendicular to a uniform magnetic field B and then spun around one of its sides at frequency f . The maximum induced emf is:
- A. BAf
 - B. BA^2f
 - C. $2BAf$
 - D. $2\pi BAf$
 - E. $4\pi BAf$
- ans: D

37. A rectangular loop of wire is placed perpendicular to a uniform magnetic field and then spun around one of its sides at frequency f . The induced emf is a maximum when:
- A. the flux is zero
 - B. the flux is a maximum
 - C. the flux is half its maximum value
 - D. the derivative of the flux with respect to time is zero
 - E. none of the above
- ans: A

38. The diagram shows a circular loop of wire that rotates at a steady rate about a diameter O that is perpendicular to a uniform magnetic field. The maximum induced emf occurs when the point X on the loop passes:

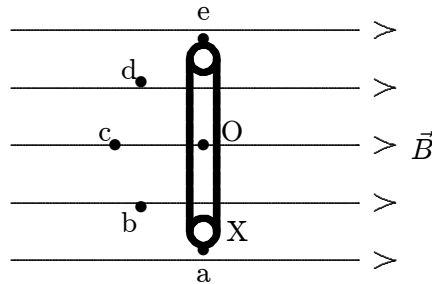

- A. a
 - B. b
 - C. c
 - D. d
 - E. e
- ans: C

39. A copper hoop is held in a vertical east-west plane in a uniform magnetic field whose field lines run along the north-south direction. The largest induced emf is produced when the hoop is:
- A. rotated about a north-south axis
 - B. rotated about an east-west axis
 - C. moved rapidly, without rotation, toward the east
 - D. moved rapidly, without rotation, toward the south
 - E. moved rapidly, without rotation, toward the northwest
- ans: B

40. A 10-turn conducting loop with a radius of 3.0 cm spins at 60 revolutions per second in a magnetic field of 0.50 T. The maximum emf generated is:
- A. 0.014 V
 - B. 0.53 V
 - C. 5.3 V
 - D. 18 V
 - E. 180 V
- ans: C
41. A single loop of wire with a radius of 7.5 cm rotates about a diameter in a uniform magnetic field of 1.6 T. To produce a maximum emf of 1.0 V, it should rotate at:
- A. 0
 - B. 2.7 rad/s
 - C. 5.6 rad/s
 - D. 35 rad/s
 - E. 71 rad/s
- ans: D
42. A merry-go-round has an area of 300 m^2 and spins at 2 rpm about a vertical axis at a place where Earth's magnetic field is vertical and has a magnitude of $5 \times 10^{-5} \text{ T}$. The emf around the rim is:
- A. 0
 - B. 0.5 mV
 - C. 3.1 mV
 - D. 15 mV
 - E. 30 mV
- ans: A

43. A copper penny slides on a horizontal frictionless table. There is a square region of constant uniform magnetic field perpendicular to the table, as shown. Which graph correctly shows the speed v of the penny as a function of time t ?

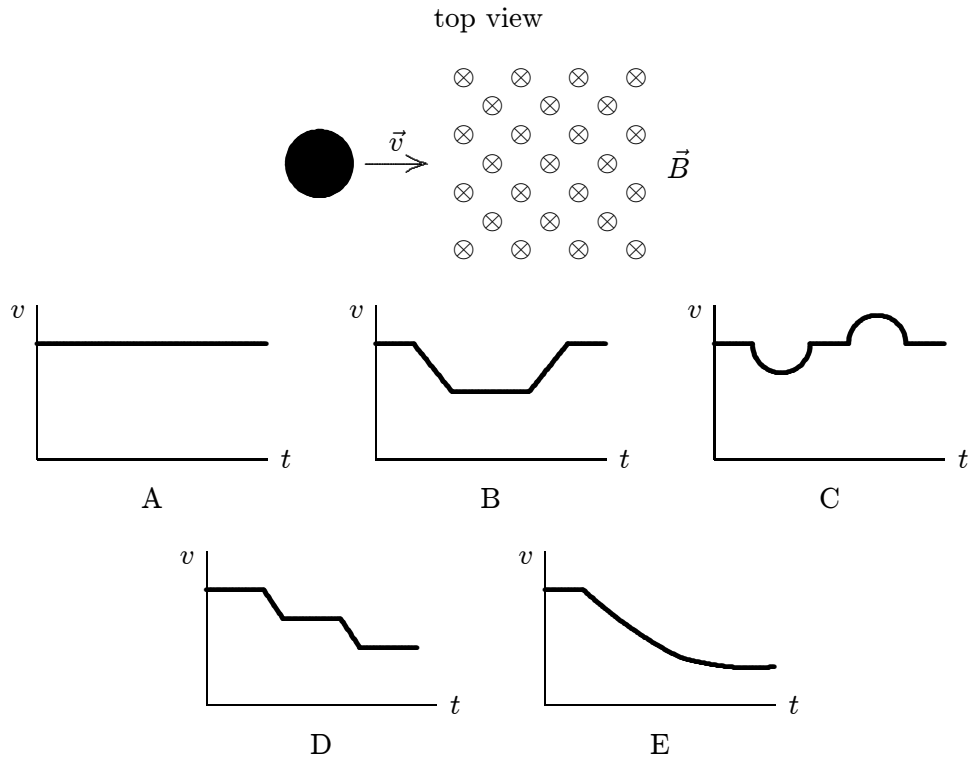

44. A rod with resistance R lies across frictionless conducting rails in a constant uniform magnetic field \vec{B} , as shown. Assume the rails have negligible resistance. The magnitude of the force that must be applied by a person to pull the rod to the right at constant speed v is:

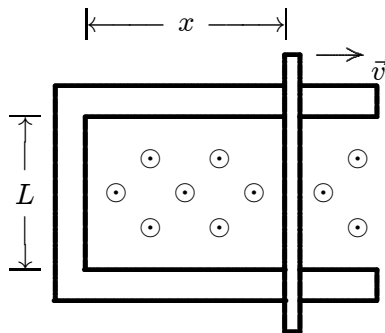

- A. 0
 B. BLv
 C. BLv/R
 D. B^2L^2v/R
 E. B^2Lxv/R

ans: D

45. A rod of length L and electrical resistance R moves through a constant uniform magnetic field \vec{B} , perpendicular to the rod. The force that must be applied by a person to keep the rod moving with constant velocity \vec{v} is:
- 0
 - BLv
 - BLv/R
 - B^2L^2v/R
 - $B^2L^2v^2/R$
- ans: A
46. As a loop of wire with a resistance of $10\ \Omega$ moves in a constant non-uniform magnetic field, it loses kinetic energy at a uniform rate of $4.0\ \text{mJ/s}$. The induced current in the loop:
- is 0
 - is $2\ \text{mA}$
 - is $2.8\ \text{mA}$
 - is $20\ \text{mA}$
 - cannot be calculated from the given data
- ans: D
47. As a loop of wire with a resistance of $10\ \Omega$ moves in a non-uniform magnetic field, it loses kinetic energy at a uniform rate of $5\ \text{mJ/s}$. The induced emf in the loop:
- is 0
 - is $0.2\ \text{V}$
 - is $0.28\ \text{V}$
 - is $2\ \text{V}$
 - cannot be calculated from the given data
- ans: B
48. An electric field is associated with every:
- magnetic field
 - time-dependent magnetic field
 - time-dependent magnetic flux
 - object moving in a magnetic field
 - conductor moving in a magnetic field
- ans: B
49. A cylindrical region of radius $R = 3.0\ \text{cm}$ contains a uniform magnetic field parallel to its axis. If the electric field induced at a point $R/2$ from the cylinder axis is $4.5 \times 10^{-3}\ \text{V/m}$ the magnitude of the magnetic field must be changing at the rate:
- 0
 - $0.30\ \text{T/s}$
 - $0.60\ \text{T/s}$
 - $1.2\ \text{T/s}$
 - $2.4\ \text{T/s}$
- ans: C

50. A cylindrical region of radius R contains a uniform magnetic field parallel to its axis. The field is zero outside the cylinder. If the magnitude of the field is changing at the rate dB/dt , the electric field induced at a point $2R$ from the cylinder axis is:
- A. zero
 - B. $2R dB/dt$
 - C. $R dB/dt$
 - D. $(R/2) dB/dt$
 - E. $(R/4) dB/dt$
- ans: E
51. A cylindrical region of radius R contains a uniform magnetic field, parallel to its axis, with magnitude that is changing linearly with time. If r is the radial distance from the cylinder axis, the magnitude of the induced electric field inside the cylinder is proportional to:
- A. R
 - B. r
 - C. r^2
 - D. $1/r$
 - E. $1/r^2$
- ans: B
52. A cylindrical region of radius R contains a uniform magnetic field, parallel to its axis, with magnitude that is changing linearly with time. If r is the radial distance from the cylinder axis, the magnitude of the induced electric field outside the cylinder is proportional to:
- A. R
 - B. r
 - C. r^2
 - D. $1/r$
 - E. $1/r^2$
- ans: D
53. The unit "henry" is equivalent to:
- A. volt·second/ampere
 - B. volt/second
 - C. ohm
 - D. ampere·volt/second
 - E. ampere·second/volt
- ans: A

54. The diagram shows an inductor that is part of a circuit. The direction of the emf induced in the inductor is indicated. Which of the following is possible?

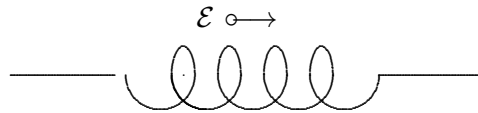

- A. The current is constant and rightward
 B. The current is constant and leftward
 C. The current is increasing and rightward
 D. The current is increasing and leftward
 E. None of the above
 ans: D
55. A 10-turn ideal solenoid has an inductance of 3.5 mH. When the solenoid carries a current of 2.0 A the magnetic flux through each turn is:
 A. 0
 B. 3.5×10^{-4} wb
 C. 7.0×10^{-4} wb
 D. 7.0×10^{-3} wb
 E. 7.0×10^{-2} wb
 ans : C
56. A 10-turn ideal solenoid has an inductance of 4.0 mH. To generate an emf of 2.0 V the current should change at a rate of:
 A. zero
 B. 5.0 A/s
 C. 50 A/s
 D. 250 A/s
 E. 500 A/s
 ans: E
57. A long narrow solenoid has length ℓ and a total of N turns, each of which has cross-sectional area A . Its inductance is:
 A. $\mu_0 N^2 A \ell$
 B. $\mu_0 N^2 A / \ell$
 C. $\mu_0 N A / \ell$
 D. $\mu_0 N^2 \ell / A$
 E. none of these
 ans: B

58. A flat coil of wire, having 5 turns, has an inductance L . The inductance of a similar coil having 20 turns is:
- A. $4L$
 - B. $L/4$
 - C. $16L$
 - D. $L/16$
 - E. L
- ans: C

59. An inductance L , resistance R , and ideal battery of emf \mathcal{E} are wired in series. A switch in the circuit is closed at time 0, at which time the current is zero. At any later time t the current i is given by:
- A. $(\mathcal{E}/R)(1 - e^{-Lt/R})$
 - B. $(\mathcal{E}/R)e^{-Lt/R}$
 - C. $(\mathcal{E}/R)(1 + e^{-Rt/L})$
 - D. $(\mathcal{E}/R)e^{-Rt/L}$
 - E. $(\mathcal{E}/R)(1 - e^{-Rt/L})$
- ans: E

60. An inductance L , resistance R , and ideal battery of emf \mathcal{E} are wired in series. A switch in the circuit is closed at time 0, at which time the current is zero. At any later time t the emf of the inductor is given by:
- A. $\mathcal{E}(1 - e^{-Lt/R})$
 - B. $\mathcal{E}e^{-Lt/R}$
 - C. $\mathcal{E}(1 + e^{-Rt/L})$
 - D. $\mathcal{E}e^{-Rt/L}$
 - E. $\mathcal{E}(1 - e^{-Rt/L})$
- ans: D

61. An inductance L , resistance R , and ideal battery of emf \mathcal{E} are wired in series. A switch in the circuit is closed at time 0, at which time the current is zero. At any later time t the potential difference across the resistor is given by:
- A. $\mathcal{E}(1 - e^{-Lt/R})$
 - B. $\mathcal{E}e^{-Lt/R}$
 - C. $\mathcal{E}(1 + e^{-Rt/L})$
 - D. $\mathcal{E}e^{-Rt/L}$
 - E. $\mathcal{E}(1 - e^{-Rt/L})$
- ans: E

62. An 8.0-mH inductor and a 2.0- Ω resistor are wired in series to an ideal battery. A switch in the circuit is closed at time 0, at which time the current is zero. The current reaches half its final value at time:
- A. 2.8 ms
 - B. 4.0 ms
 - C. 3 s
 - D. 170 s
 - E. 250 s
- ans: A

63. An 8.0-mH inductor and a 2.0- Ω resistor are wired in series to a 20-V ideal battery. A switch in the circuit is closed at time 0, at which time the current is zero. After a long time the current in the resistor and the current in the inductor are:
- A. 0, 0
 - B. 10 A, 10 A
 - C. 2.5 A, 2.5 A
 - D. 10 A, 2.5 A
 - E. 10 A, 0
- ans: B
64. An 8.0-mH inductor and a 2.0- Ω resistor are wired in series to a 20-V ideal battery. A switch in the circuit is closed at time 0, at which time the current is zero. Immediately after the switch is thrown the potential differences across the inductor and resistor are:
- A. 0, 20 V
 - B. 20 V, 0
 - C. 10 V, 10 V
 - D. 16 V, 4 V
 - E. unknown since the rate of change of the current is not given
- ans: B
65. An inductor with inductance L resistor with resistance R are wired in series to an ideal battery with emf \mathcal{E} . A switch in the circuit is closed at time 0, at which time the current is zero. A long time after the switch is thrown the potential differences across the inductor and resistor:
- A. 0, \mathcal{E}
 - B. \mathcal{E} , 0
 - C. $\mathcal{E}/2$, $\mathcal{E}/2$
 - D. $(L/R)\mathcal{E}$, $(R/L)\mathcal{E}$
 - E. cannot be computed unless the rate of change of the current is given
- ans: A
66. If both the resistance and the inductance in an LR series circuit are doubled the new inductive time constant will be:
- A. twice the old
 - B. four times the old
 - C. half the old
 - D. one-fourth the old
 - E. unchanged
- ans: E

67. When the switch S in the circuit shown is closed, the time constant for the growth of current in R_2 is:

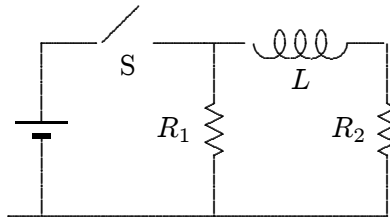

- A. L/R_1
 B. L/R_2
 C. $L/(R_1 + R_2)$
 D. $L(R_1 + R_2)/(R_1 R_2)$
 E. $(L/R_1 + L/R_2)/2$

ans: B

68. The diagrams show three circuits with identical batteries, identical inductors, and identical resistors. Rank them according to the current through the battery just after the switch is closed, from least to greatest.

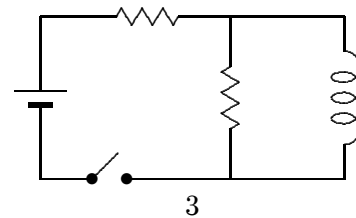
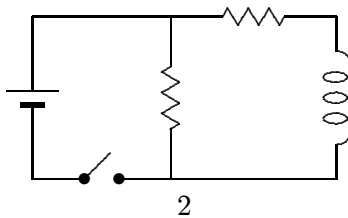
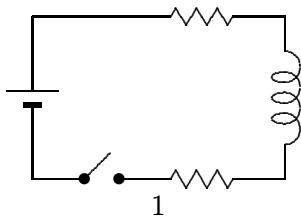

- A. 3, 2, 1
 B. 2 and 3 ties, then 1
 C. 1, 3, 2
 D. 1, 2, 3
 E. 3, 1, 2

ans: C

69. Immediately after switch S in the circuit shown is closed, the current through the battery is:

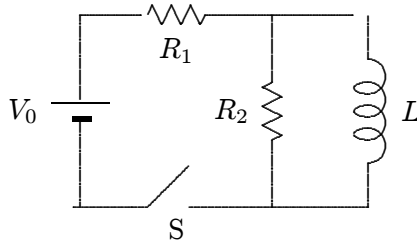

- A. 0
B. V_0/R_1
C. V_0/R_2
D. $V_0/(R_1 + R_2)$
E. $V_0(R_1 + R_2)/(R_1R_2)$
ans: D
70. A 3.5-mH inductor and a 4.5-mH inductor are connected in series. The equivalent inductance is:
A. 2.0 mH
B. 0.51 mH
C. 0.13 mH
D. 1.0 mH
E. 8.0 mH
ans: E
71. A 3.5-mH inductor and a 4.5-mH inductor are connected in series and a time varying current is established in them. When the total emf of the combination is 16 V, the emf of the larger inductor is:
A. 7.0 V
B. 9.0 V
C. 2.3 V
D. 28 V
E. 36 V
ans: B
72. A 3.5-mH inductor and a 4.5-mH inductor are connected in parallel. The equivalent inductance is:
A. 2.0 mH
B. 0.51 mH
C. 0.13 mH
D. 1.0 mH
E. 8.0 mH
ans: A

73. A 3.5-mH inductor and a 4.5-mH inductor are connected in parallel. When the total emf of the combination is 16 V, the rate of change of the current in the larger inductor is:
- A. 2.0×10^3 A/s
 - B. 3.6×10^3 A/s
 - C. 4.6×10^3 A/s
 - D. 7.0×10^3 A/s
 - E. 8.1×10^3 A/s
- ans: B
74. An inductor with inductance L and an inductor with inductance $2L$ are connected in parallel. When the rate of change of the current in the larger inductor is 1200 A/s the rate of change of the current in the smaller inductor is:
- A. 400 A/s
 - B. 1200 A/s
 - C. 1600 A/s
 - D. 2000 A/s
 - E. 2400 A/s
- ans: E
75. The stored energy in an inductor:
- A. depends, in sign, upon the direction of the current
 - B. depends on the rate of change of current
 - C. is proportional to the square of the inductance
 - D. has units J/H
 - E. none of the above
- ans: E
76. An inductance L and a resistance R are connected in series to an ideal battery. A switch in the circuit is closed at time 0, at which time the current is zero. The energy stored in the inductor is a maximum:
- A. just after the switch is closed
 - B. at the time $t = L/R$ after the switch is closed
 - C. at the time $t = L/R$ after the switch is closed
 - D. at the time $t = 2L/R$ after the switch is closed
 - E. a long time after the switch is closed
- ans: E
77. An inductance L and a resistance R are connected in series to an ideal battery. A switch in the circuit is closed at time 0, at which time the current is zero. The rate of increase of the energy stored in the inductor is a maximum:
- A. just after the switch is closed
 - B. at the time $t = L/R$ after the switch is closed
 - C. at the time $t = L/R$ after the switch is closed
 - D. at the time $t = (L/R) \ln 2$ after the switch is closed
 - E. a long time after the switch is closed
- ans: D

78. In each of the following operations, energy is expended. The LEAST percentage of returnable electrical energy will be yielded by:
- A. charging a capacitor
 - B. charging a storage battery
 - C. sending current through a resistor
 - D. establishing a current through an inductor
 - E. moving a conducting rod through a magnetic field
- ans: C
79. A current of 10 A in a certain inductor results in a stored energy of 40 J. When the current is changed to 5 A in the opposite direction, the stored energy changes by:
- A. 20 J
 - B. 30 J
 - C. 40 J
 - D. 50 J
 - E. 60 J
- ans: B
80. A 6.0-mH inductor is in a series circuit with a resistor and an ideal battery. At the instant the current in the circuit is 5.0 A the energy stored in the inductor is:
- A. 0
 - B. 7.5×10^{-2} J
 - C. 15×10^{-2} J
 - D. 30×10^{-2} J
 - E. unknown since the rate of change of the current is not given
- ans: B
81. A 6.0-mH inductor is in a circuit. At the instant the current is 5.0 A and its rate of change is 200 A/s, the rate with which the energy stored in the inductor is increasing is:
- A. 7.5×10^{-2} W
 - B. 120 W
 - C. 240 W
 - D. 3.0 W
 - E. 6.0 W
- ans: E
82. A 6.0-mH inductor and a 3.0- Ω resistor are wired in series to a 12-V ideal battery. A switch in the circuit is closed at time 0, at which time the current is zero. 2.0 ms later the energy stored in the inductor is:
- A. 0
 - B. 2.5×10^{-2} J
 - C. 1.9×10^{-2} J
 - D. 3.8×10^{-2} J
 - E. 9.6×10^{-3} J
- ans: C

83. The quantity B^2/μ_0 has units of:

- A. J
- B. J/H
- C. J/m
- D. J/m^3
- E. H/m^3

ans: D

84. A 0.20-cm radius cylinder, 3.0 cm long, is wrapped with wire to form an inductor. At the instant the magnetic field in the interior is 5.0 mT the energy stored in the field is about:

- A. 0
- B. $3.8 \times 10^{-6} \text{ J}$
- C. $7.5 \times 10^{-6} \text{ J}$
- D. $7.5 \times 10^{-4} \text{ J}$
- E. 9.9 J

ans: B

85. In the diagram, assume that all the magnetic field lines generated by coil 1 pass through coil 2. Coil 1 has 100 turns and coil 2 has 400 turns. Then:

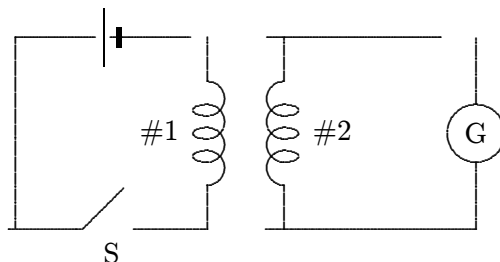

- A. the power supplied to coil 1 is equal to the power delivered by coil 2
- B. the emf around coil 1 will be one-fourth the emf around coil 2
- C. the current in coil 1 will be one-fourth the current in coil 2
- D. the emfs will be the same in the two coils
- E. none of the above

ans: E