

# Images Formed by Plane Mirrors

Tuesday, April 5, 2022 10:47 PM

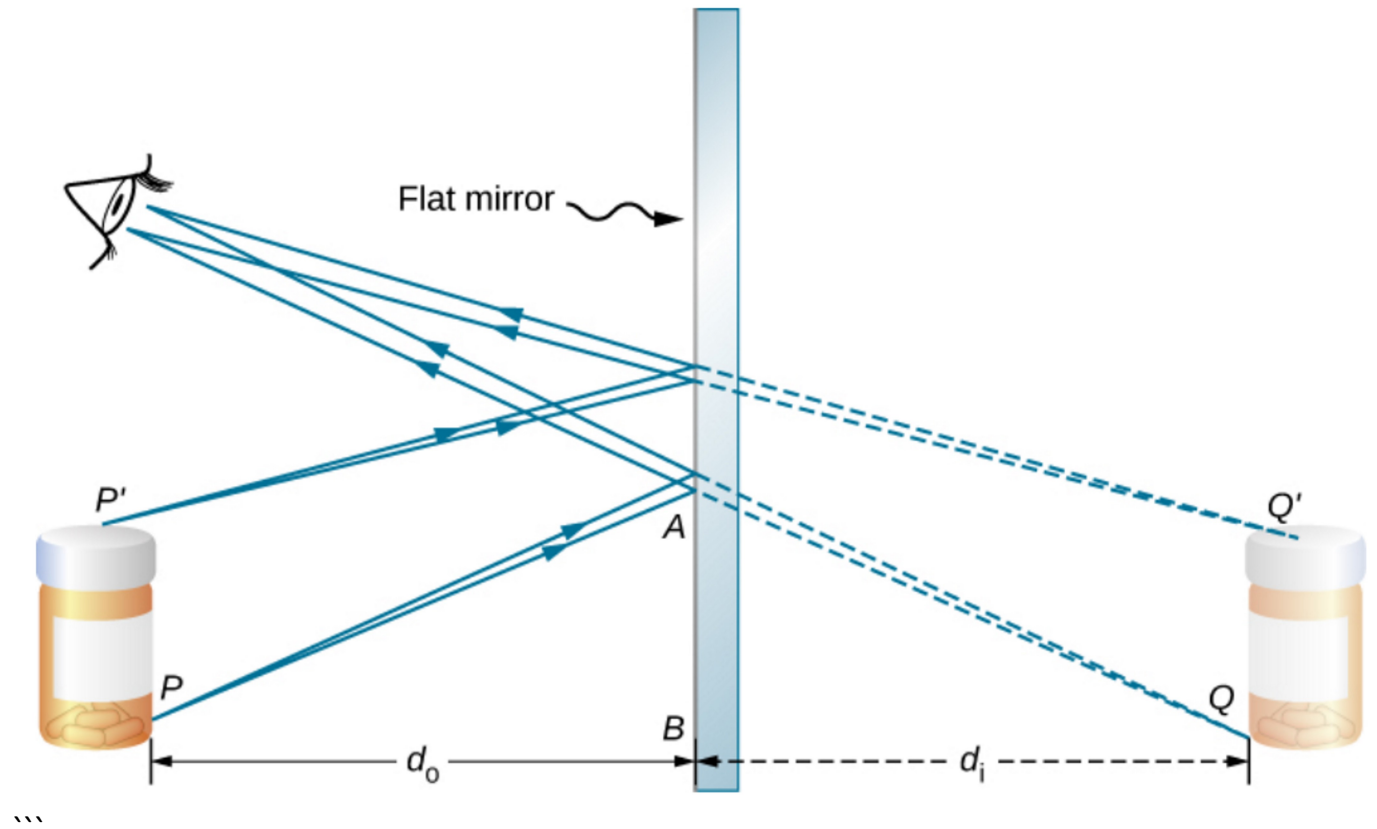

## Two plane mirrors at right angle

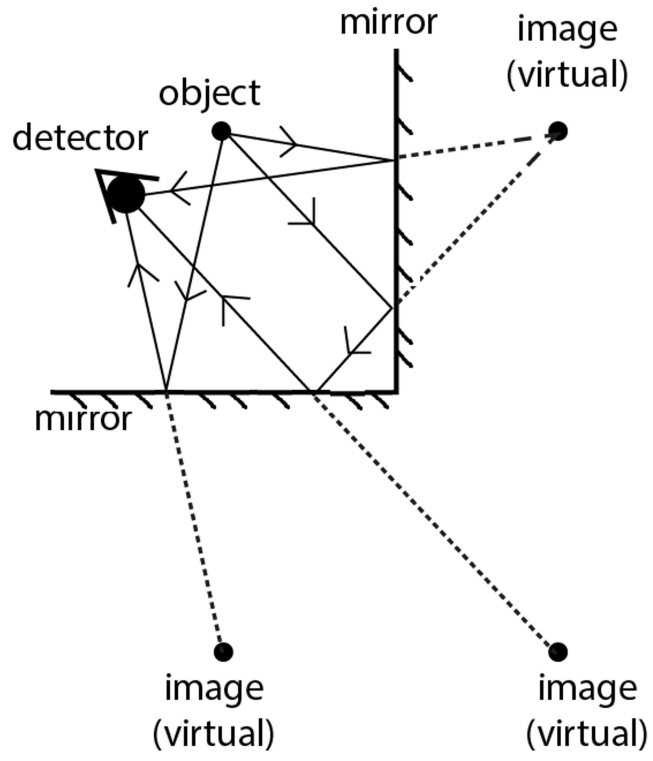

# Spherical Mirrors

Tuesday, April 5, 2022 10:51 PM

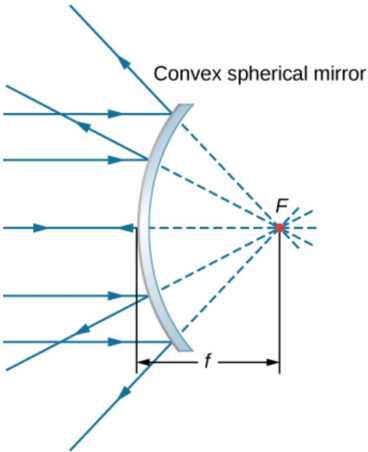
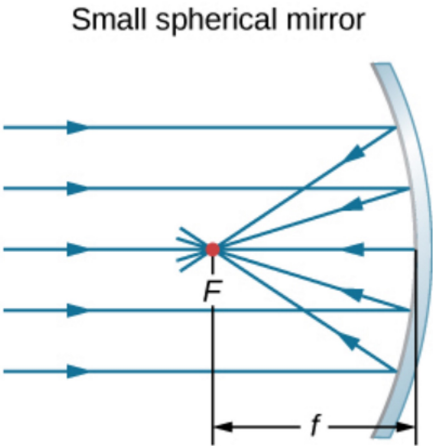
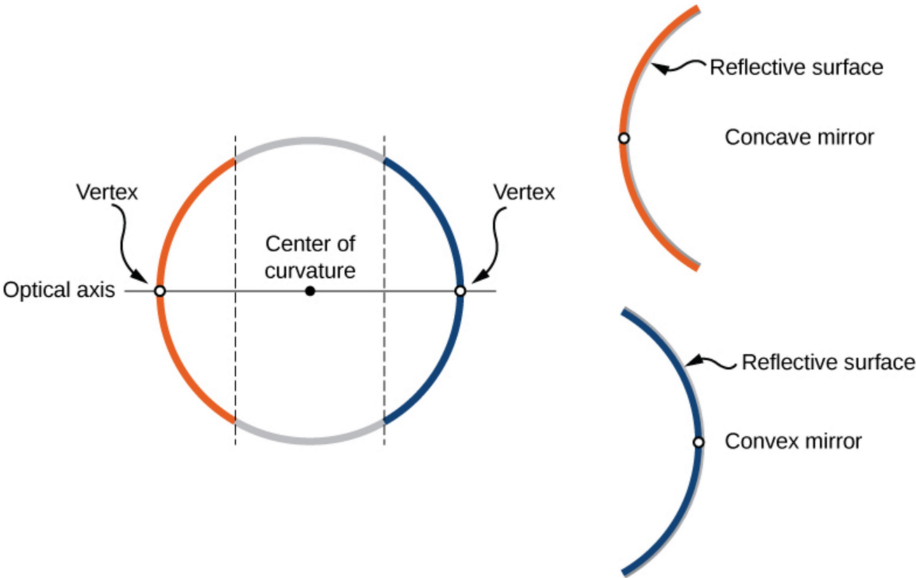



Convex mirror



Convex mirror



Concave mirror

## Using Ray Tracing to Locate Images

Tuesday, April 5, 2022 11:03 PM

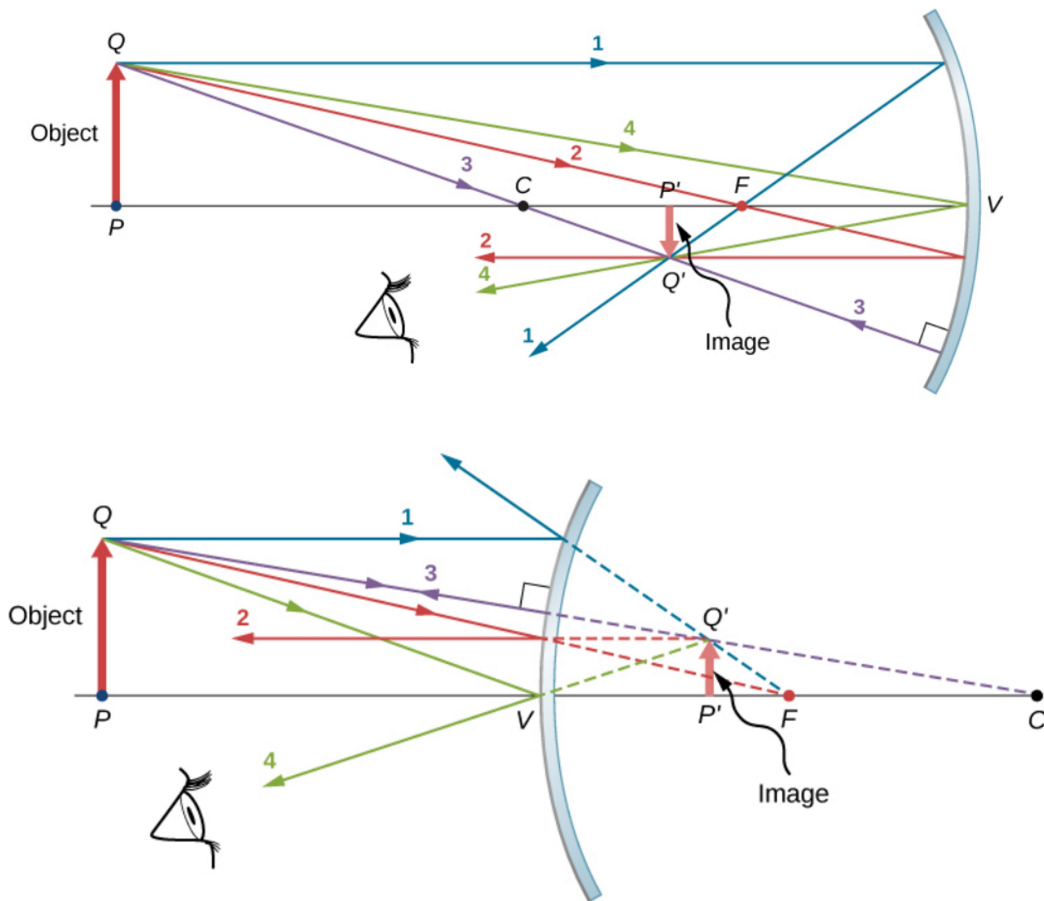

### Ray-Tracing Rules

Ray tracing is very useful for mirrors. The rules for ray tracing are summarized here for reference:

- A ray traveling parallel to the optical axis of a spherical mirror is reflected along a line that goes through the focal point of the mirror (ray 1 in Figure 2.3.5).
- A ray traveling along a line that goes through the focal point of a spherical mirror is reflected along a line parallel to the optical axis of the mirror (ray 2 in Figure 2.3.5).
- A ray traveling along a line that goes through the center of curvature of a spherical mirror is reflected back along the same line (ray 3 in Figure 2.3.5).
- A ray that strikes the vertex of a spherical mirror is reflected symmetrically about the optical axis of the mirror (ray 4 in Figure 2.3.5).

## Image Formation by Reflection—The Mirror Equation

Tuesday, April 5, 2022 11:11 PM

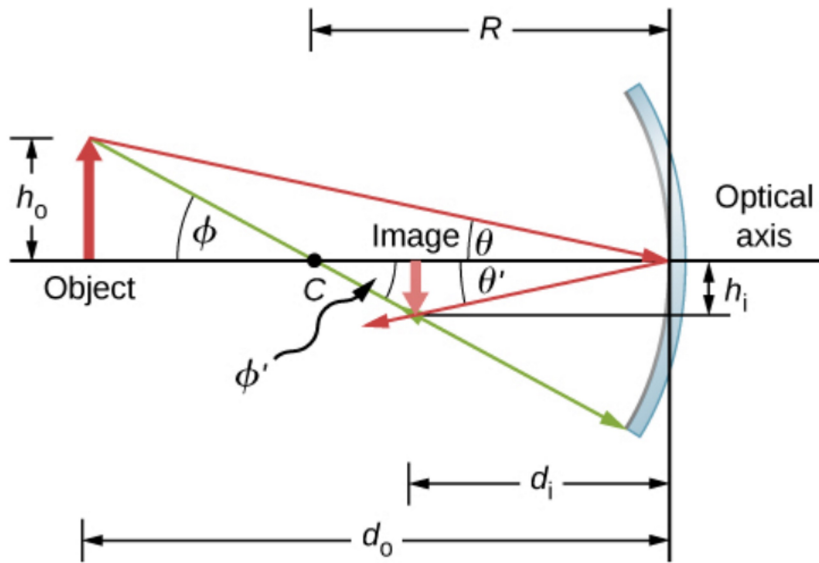

Figure 2.3.6: Image formed by a concave mirror.

$$\left. \begin{aligned} \tan \theta &= \frac{h_o}{d_o} \\ \tan \theta' &= -\tan \theta = \frac{h_i}{d_i} \end{aligned} \right\} = \frac{h_o}{d_o} = -\frac{h_i}{d_i}$$

$$-\frac{h_o}{h_i} = \frac{d_o}{d_i}.$$

$$\left. \begin{aligned} \tan \phi &= \frac{h_o}{d_o - R} \\ \tan \phi' &= -\tan \phi = \frac{h_i}{R - d_i} \end{aligned} \right\} = \frac{h_o}{d_o - R} = -\frac{h_i}{R - d_i}$$

$$-\frac{h_o}{h_i} = \frac{d_o - R}{R - d_i}.$$

$$\frac{d_o}{d_i} = \frac{d_o - R}{R - d_i}.$$

$$\frac{1}{d_o} + \frac{1}{d_i} = \frac{2}{R}.$$

$$\frac{1}{d_o} + \frac{1}{d_i} = \frac{1}{f}.$$

mirror equation

### Sign convention for spherical mirrors

Using a consistent sign convention is very important in geometric optics. It assigns positive or negative values for the quantities that characterize an optical system. Understanding the sign convention allows you to describe an image without constructing a ray diagram. This text uses the following sign convention:

1. The focal length  $f$  is positive for concave mirrors and negative for convex mirrors.
2. The image distance  $d_i$  is positive for real images and negative for virtual images.



# Image Magnification

Tuesday, April 5, 2022 11:19 PM

$$-\frac{h_o}{h_i} = \frac{d_o}{d_i}.$$

$$m = \frac{h_i}{h_o}.$$

linear magnification

$$m = \frac{h_i}{h_o} = -\frac{d_i}{d_o}.$$

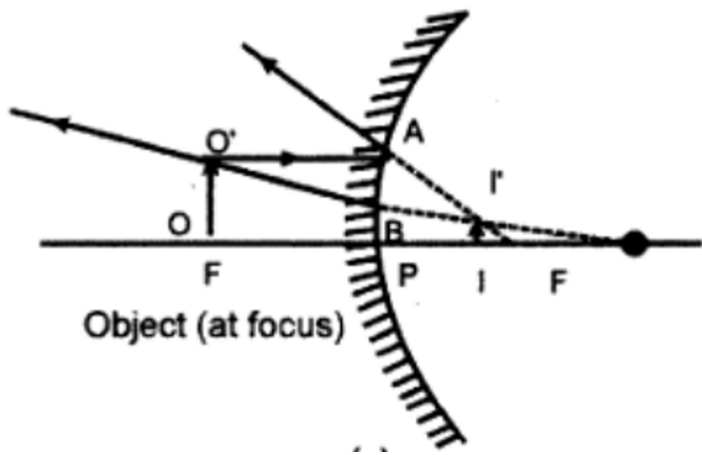
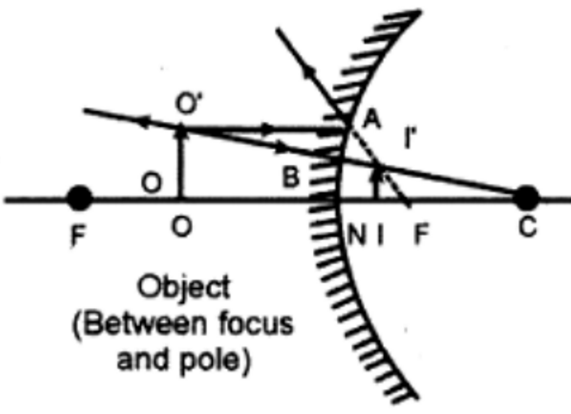
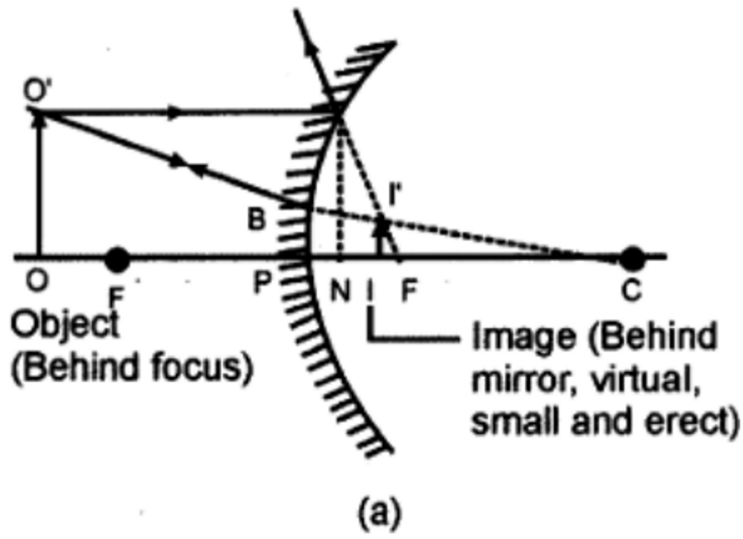

# Derivation of spherical mirror formula

Wednesday, April 6, 2022 8:33 PM

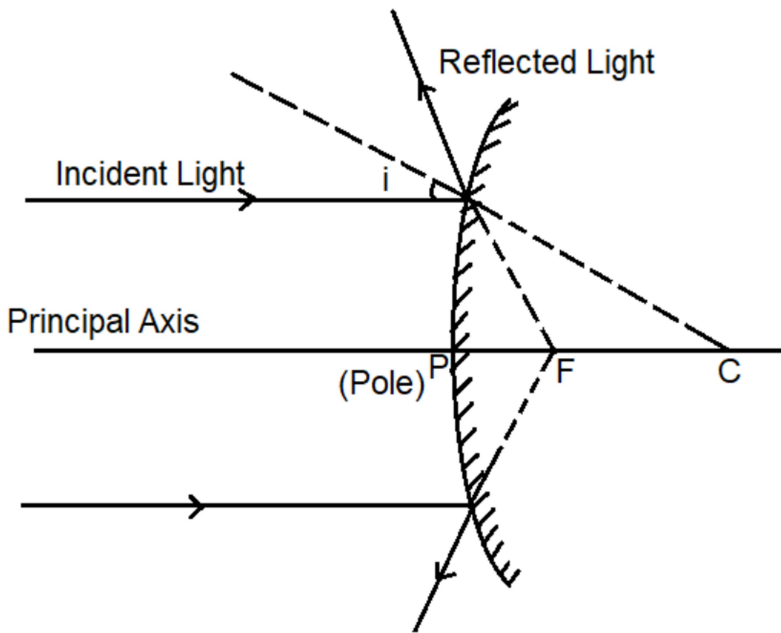
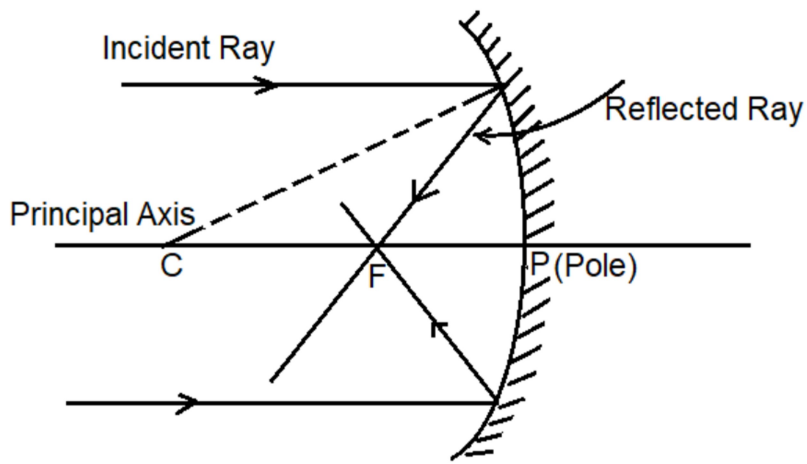

# Sign convention

Wednesday, April 6, 2022 8:35 PM

## Cartesian Sign Convention

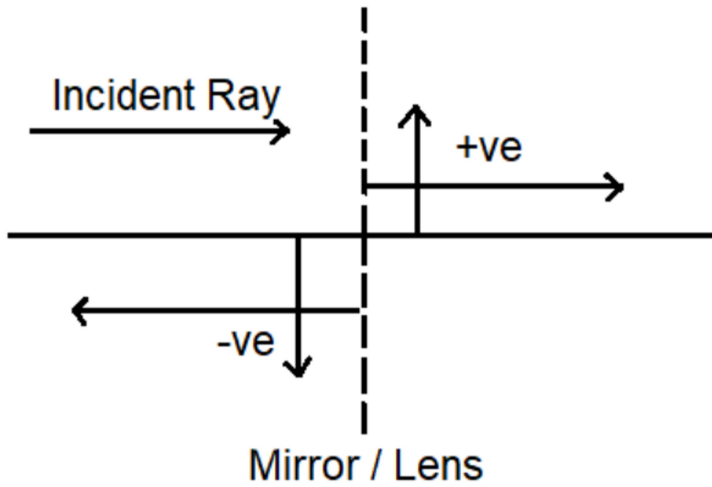

(i) All distances are measured from the pole of the mirror / lens / refracting surface which should be placed at the origin.

When applying the mirror formula, it is necessary to observe the following points:

- That all distances are measured from the mirror as the origin.
- All real distances are positive while all virtual distances are negative.
- A concave mirror has a positive focal length while a convex mirror has a negative focal length.

### Example

1. Determine the position, size and nature of the image of an object 4cm tall placed on the principal axis of a concave mirror of focal length 15cm at a distance 30cm from the mirror.

#### solution

$$u=30\text{cm}, f= 15\text{cm}, h_o=4\text{cm}$$

$$1/v=1/f-1/u$$

$$= 1/15 - 1/30 = 1/30$$

$$v = 30\text{cm}$$

$$\text{Also, } m=v/u = h_i/h_o$$

$$\text{Thus, } h_i=(30\text{cm} \times 4\text{cm})/30\text{cm} =4\text{cm}.$$

Thus the image formed is real and same size as the object.

**If an object is 30cm in front of a convex mirror that had a focal length of 60cm, how far behind the mirror will the image appear to an observer? How tall will the image be?**

If an object is 30cm in front of a convex mirror that had a focal length of 60cm, how far behind the mirror will the image appear to an observer? How tall will the image be?

$$d_i = -20\text{cm}, h_i = (2/3)h_o$$

# Mirror formula

Wednesday, April 6, 2022 8:48 PM

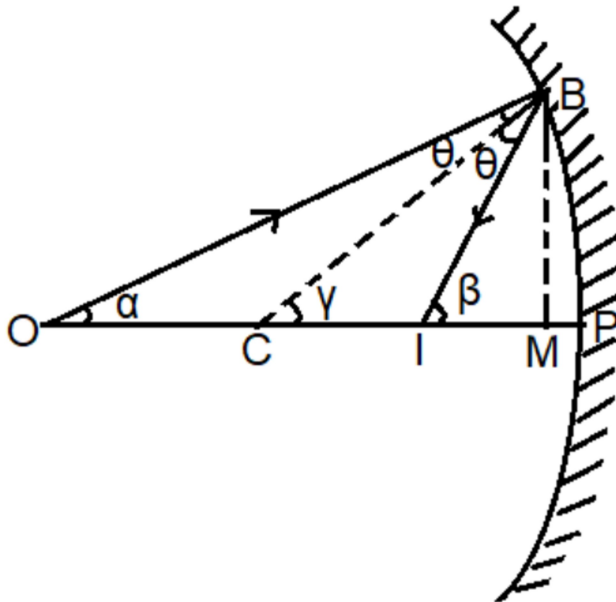

$$\alpha + \theta = \gamma, \gamma + \theta = \beta$$

$$\Rightarrow \alpha + \beta = 2\gamma$$

For small aperture of the mirror,  $\alpha, \beta, \gamma \rightarrow 0$

$\Rightarrow \alpha \approx \tan \alpha, \beta \approx \tan \beta, \gamma \approx \tan \gamma$  &  $M \rightarrow P$  (for paraxial rays)

$$\Rightarrow \tan \alpha + \tan \beta = 2 \tan \gamma$$

$$\frac{BM}{MO} + \frac{BM}{MI} = 2\frac{BM}{MC}$$

$$\frac{1}{MO} + \frac{1}{MI} = \frac{2}{MC}$$

$$\frac{1}{PO} + \frac{1}{PI} = \frac{2}{PC}$$

Applying Sign convention,

$$-\frac{1}{u} + \frac{1}{-v} = -\frac{2}{R}$$

$$\frac{1}{u} + \frac{1}{v} = \frac{2}{R}$$



$$u = \infty$$

$$\frac{1}{v} = \frac{2}{R}$$

If  $u = \infty$ ,  $v = f$

Hence,  $f = R/2$  and

$$\frac{1}{v} + \frac{1}{u} = \frac{1}{f}$$

# Simple telescope (Refracting and reflecting)

Wednesday, April 6, 2022 9:03 PM

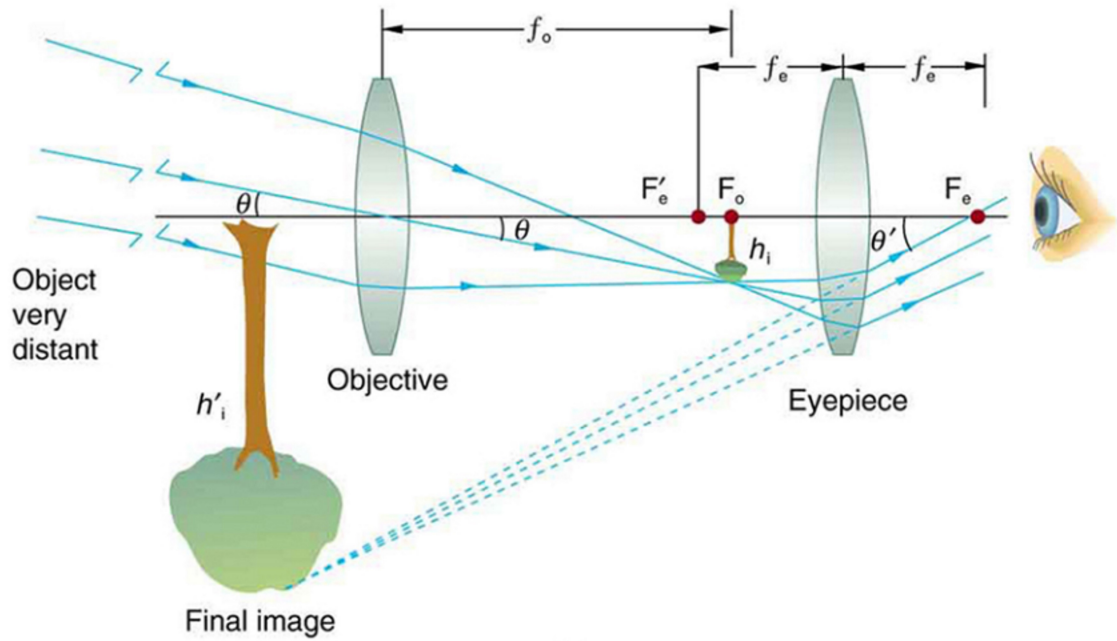

$$M = \frac{\theta'}{\theta} = -\frac{f_o}{f_e}$$

## Reflecting Telescopes

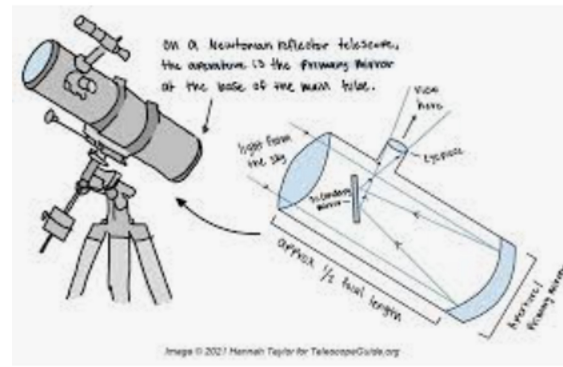
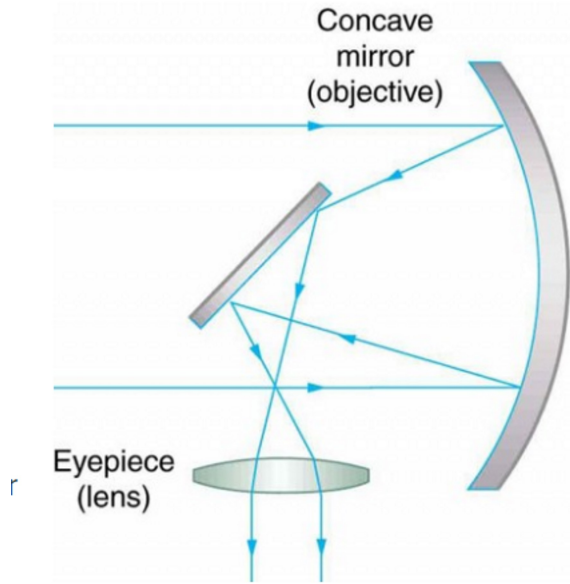

# Simple Microscope

Wednesday, April 6, 2022 9:23 PM

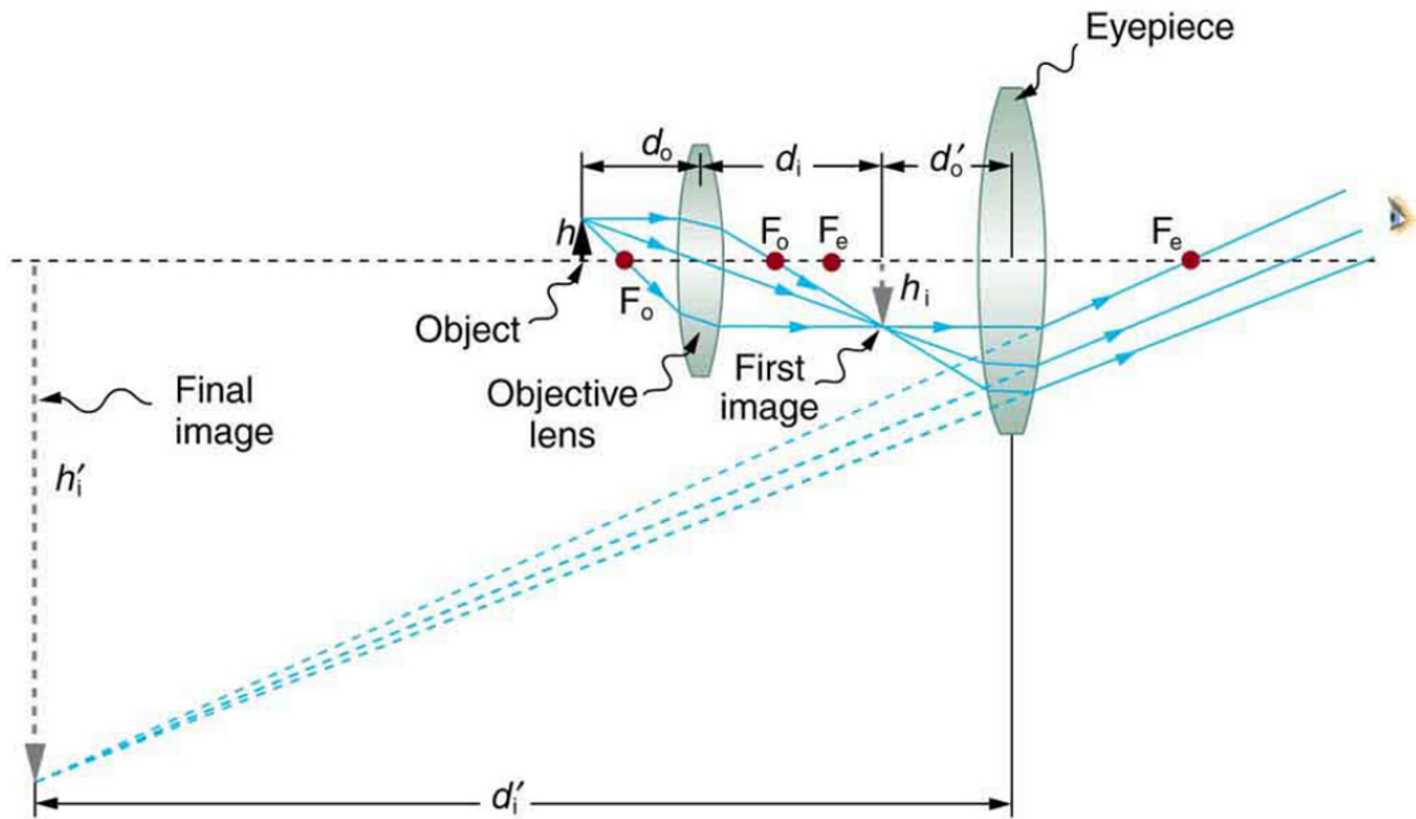
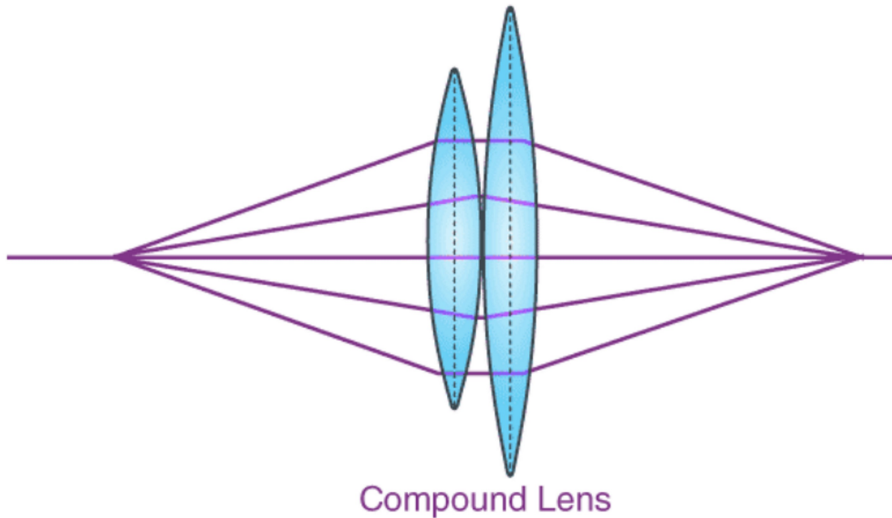

Figure 2. A compound microscope composed of two lenses, an objective and an eyepiece. The objective forms a case 1 image that is larger than the object. This first image is the object for the eyepiece. The eyepiece forms a case 2 final image that is further magnified.

$$m_o = -\frac{d_i}{d_o}$$

# Compound lenses

Wednesday, April 6, 2022 9:51 PM



$$\frac{1}{f} = \frac{1}{f_1} + \frac{1}{f_2}$$

$$\frac{1}{f} = \frac{1}{f_1} + \frac{1}{f_2} - \frac{d}{f_1 \cdot f_2}$$

## Application of Compound Lenses

We find compounded lenses used in telescopes and microscopes where two or more lenses are combined in order to:

- Reduce defects caused by using a single lens.
- Get an erect image of an object.
- Increase the magnification of the image.