

BIRZEIT UNIVERSITY



Construction Materials Laboratory Manual

[2016]

Table of Contents

Chapter One: Aggregates and their Tests	2
Chapter Two: Fresh Concrete Tests	33
Chapter Three: Job Mix Design (Developed from ACI and British Standard)	74
Chapter Four: Air Content of Freshly Mixed Concrete by the Pressure Method	101
Chapter Five: Non-destructive tests for Hardened concrete.....	108
Chapter Six: Core Test.....	128
Chapter Seven: Test on Asphalt and Bituminous Materials	139
Chapter eight: Test on Metals.....	157
References	166
Appendices.....	168

Chapter One: Aggregates and their Tests

1.1 Introduction

Aggregate may be defined as the solid materials contained in concrete which play no part in the chemical reactions that cause the concrete to set. Aggregate can be classified as Normal weight or Lightweight.

Normal weight aggregates generally consist of various combinations of naturally occurring sands, gravel and stones, and of different sizes of crushed rock. Their relative densities usually lie between 2.4 and 2.9 and their strength is at least as great as that of normal cement mortar.

Lightweight aggregates are generally manufactured (for example expanded clay or expanded shale) but can also be natural rock (for example pumice). Their relative densities usually lie between 1.2 and 2.0 and their strength is normally less than that of normal cement mortar

It is usual to consider the fine aggregate and the coarse aggregate in a concrete mix separately. The fine aggregate which could be either crushed or uncrushed is defined as containing a high proportion of particles passing a 5mm (0.197 in.) sieve, while the coarse aggregate is defined as containing a high proportion of particles retained by a 5mm (0.197 in.) sieve. In the US and elsewhere a 4.75mm (0.187 in.) sieve is used as the limit.

1.2 Type of fine aggregate

As previously mentioned, fine aggregate could be classified into two types which are crushed or uncrushed. Uncrushed aggregates are usually smoother than crushed aggregates and in comparison with concrete made with crushed fine aggregate, concrete containing uncrushed fine aggregate will generally have superior workability. Furthermore, Crushed aggregate is angular and uncrushed aggregate is smooth.

- An angularity of 0% corresponds to uncrushed aggregate.
- An angularity of 100% corresponds to crushed aggregate.

However, an angularity of 25% might be specified for a somewhat angular uncrushed aggregate or an angularity of 75% might be specified for a relatively smooth crushed aggregate. The overall angularities of the fine and coarse aggregate are calculated as the average of the angularities by volume, weighted by the reciprocal of the size.

1.3 Sampling of aggregate (Developed from AASHTO T 2)

The most important phase of an aggregate inspector's duties is securing a representative sample. At this point, all the money and time which will be expended on the remaining activities of testing and evaluation may be lost or rendered useless by an improper sampling technique. In other words, if the samples taken are not representative of the total material, it is impossible to end up with meaningful test results. At the completion of this instruction, the technician must

know how to obtain a proper sample. Without this knowledge, it is useless to proceed further into the areas of the test procedures.

Test samples should represent the total amount of the material being produced or used. This is normally accomplished by random sampling. All material should have an equal chance of being tested. Random samples are taken when the plant or operation is continuing at the usual rate. During production at the source, care must be taken to ensure the virgin material being processed is normal to the overall consistency of the available material. Clay pockets, boulders or varying seams in a gravel pit, mine, or quarry may create short-term variations in the consistency of the product.

There are four methods approved by AASHTO for securing aggregate samples. The method the technician uses depends on the type of aggregate they are sampling, the location of the sample, and the equipment available at the sampling location. The four methods include:

- Flowing Aggregate Stream (Bins or Belt Discharge)
- Conveyor Belt
- Stockpiles or Transportation Units
- Roadway (Bases and Subbases)

The most accurate way to ensure that aggregate, as produced, meets the requirements would be to test the entire stockpile. This would not only be impractical, but virtually impossible. Accurate, representative samples must be secured for testing to ensure the required characteristics are met.

Aggregate samples may be obtained at different stages of production or construction:

- Preliminary source investigation to determine potential end product. These samples are normally obtained by the party responsible for development of the source.
- During aggregate production at the source, samples of materials for control of the production at the source are obtained by the manufacturer, contractor or other parties responsible for the work such as private consultants.
- Control of the operations at the job site is also the responsibility of the producer, contractor or other qualified parties.
- Samples to determine acceptance or rejection by the purchaser are obtained by the purchaser or an authorized representative.

Samples secured for the purpose of quality testing such as soundness, clay content, resistance to abrasion, etc., should be obtained from the finished product when possible. Samples from the finished product to be tested for resistance to abrasion shall not be subject to further crushing or manual reduction in particle size unless the size of the finished product is such that it requires further reduction for testing purposes.

1.4 Common sampling errors

- Using improper sampling device
- Sampling in segregated areas
- Not obtaining enough increments
- Improper sampling method for aggregate types (sand, fine aggregate, coarse aggregate)
- Allowing overflowing in a stream flow device

1.5 Important definitions

- Fine Aggregate - Fine Aggregate - An aggregate sample with predominately material which will pass the 4.75 mm (#4) sieve.
- Coarse Aggregate - Normally an aggregate consisting of particles predominately larger than a 4.75 mm (#4) sieve. For the purposes of this test method, coarse aggregate is defined as any aggregate sample containing 50 percent or more particles retained on the 4.75 mm (#4) sieve.
- Combined Aggregate - An aggregate containing both coarse and fine particles in a relatively even amount.

1.6 Reduction of the sample (Developed from AASHTO T 248)

Aggregate and other materials sampled in the field need to be reduced to appropriate sizes for testing. It is, therefore, necessary to reduce field samples while minimizing the chance of variability during handling. In some instances a few particles on a given sieve might affect a gradation significantly enough to alter an interpretation of the field sample and subsequently the entire lot's compliance with specifications. The appropriate field sample reduction method is dependent chiefly on the nominal maximum size of the aggregate, the amount of free moisture in the sample, and the equipment available.

Minimum sample sizes for sieve analysis of aggregates are based on the maximum size of the product and the intended use. The following table lists the required minimum field sample and test sample sizes based on the smallest sieve through which at least 95% of the sample will pass. However, if the products which has a maximum sizes are over 1½ in. (37.5 mm) are normally visually inspected, an appropriate District Materials Engineer should be contacted.

Sieve size	Field sample(lbs./kg)	Test Sample(gms/kg)
1½ in. (37.5 mm)	50/23.0	5,000/5.0 ⁽²⁾
1 in. (25.0 mm)	30/13.5	3,500/3.5
¾ in. (19.0 mm)	20/9.0	2,000/2.0
½ in. (12.5 mm)	20/9.0	1,500/1.5
3/8 in. (9.5 mm)	10/4.5	1,000/1.0 ⁽¹⁾
#4 sieve (4.75mm)	10/4.5	500/0.5
#8 sieve (2.36mm)	10/4.5	200/0.2

⁽¹⁾ When testing fine aggregate for PC Concrete, the minimum test sample is 500 grams.

⁽²⁾ When testing 1 1/2" aggregate for Special Backfill, Granular Subbase, or Modified Subbase the minimum test sample is 2500 grams.

Table 1-1: List required minimum field sample and test sample sizes based on the smallest sieve

Source: Iowa Department of Transportation, (2002)

In order to select the appropriate reduction method for the aggregate to be tested, Table 1-2 should be used.

Reduction procedure		
Mechanical Splitter	Quartering	Miniature Stockpile
Fine Aggregates - Air Dry	Fine Aggregates - Free Moisture on the Particle Surface	Fine Aggregate – Free Moisture on the Particle Surface
Coarse Aggregates	Coarse Aggregates	Not Appropriate for Coarse Aggregate
Combined Aggregates	Combined Aggregates with Free Moisture on the Particle Surface	Not Appropriate for Combined Aggregate

Table 1-2: Selecting the appropriate method of reduction for aggregate

Source: Developed from Multi-Regional Aggregate Training and Certification Group (2006)

In this laboratory manual just the mechanical splitter and the quartering will be described.

1) Sample Reduction - Method A (Mechanical Splitter)

Mechanical splitters are commonly available in sizes adequate for aggregate having the largest particle size not over 37.5 mm (1½ in.). Furthermore, it is the preferred method of sample reduction and should be used when practicable. In order to perform the reduction of sample using this method, the following apparatus are needed:

- The mechanical sample splitter must have an even number of equal width chutes, not less than eight for coarse or combined aggregate, or twelve for fine aggregate.
- The chutes must discharge alternately to each side of the splitter.
- For coarse and combined aggregates the minimum width of the individual chutes shall be approximately fifty percent larger than the largest size particle in the sample to be reduced.
- For dry fine aggregate in which the entire sample will pass the 9.5 mm (¾ in.) sieve, the minimum width of the chutes shall be at least fifty percent larger than the largest particles in the sample with a maximum width of 19 mm (¾ in.).

- The splitter must be equipped with at least two receptacles (catch pans) to hold the two halves of the sample during splitting.
- It shall also be equipped with a hopper or straightedge pan with a width equal to or slightly less than the overall width of the assembly of chutes, by which the sample may be fed at a controlled rate into the chutes.
- The splitter and accessories shall be designed to allow the sample to flow smoothly without restriction or loss of material.

a) Sample preparation

Using the mechanical splitter to reduce a fine aggregate sample, the aggregate should be in an air-dry condition. The entire sample may be dried to at least a saturated surface dry condition using temperatures that do not exceed those specified for any of the tests intended to be performed on the material. However, if the damp, fine aggregate sample is too large to efficiently dry in this manner, a preliminary split may be performed using a mechanical splitter with chute openings no smaller than 37.5 mm (1½ in.). Reduce the sample to not less than 5000 g and dry this sample. Reduce the dried sample using a mechanical splitter with individual chute openings not to exceed 19 mm (¾ in.) to the required test sample size(s).

When reducing a coarse aggregate by mechanical splitting, the sample may be reduced in a damp condition taking care that any fine particles adhering to the chutes are brushed into the catch pans. Samples containing excess water should be allowed to drain before reduction is attempted. Combined aggregates may also be reduced in a damp condition, as long as the aggregate flows freely through the chute openings without plugging and any small particles adhering to the chutes are brushed into the catch pans. When practicable, allow all samples to attain an air-dry condition before using a mechanical splitter.

b) Reduction procedure

- Place the original sample, or portion thereof, in the hopper or pan and uniformly distribute it from edge to edge being sure the sample appears homogenous (well blended).
- Carefully introduce the sample into the chutes in a manner to allow the aggregate to flow freely through the openings and into the catch pans. Continue this procedure until the entire large sample has been halved, being careful that catch pans do not overflow.
- Remove the catch pans and set aside. Continue splitting the other half into quarters. Follow this procedure, being sure to split entire increments, until the desired test sample size is obtained.
- Retain the unused material until all desired tests are performed in case a retest is needed.

Figures 1-1 and 1-2 show respectively the large splitter riffle samplers for coarse and fine aggregate.

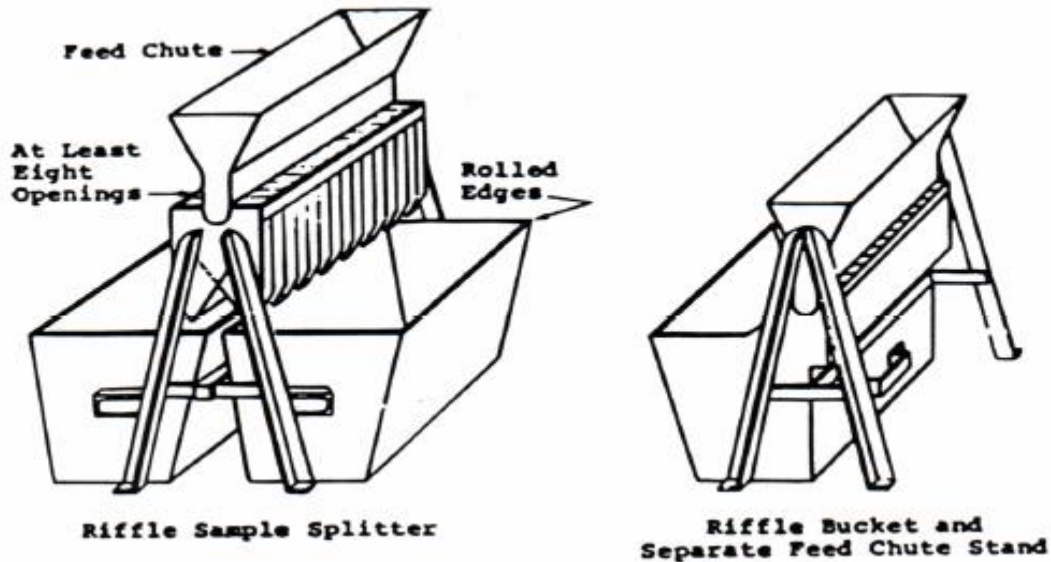

Fig.1-1: Large riffle samplers for coarse aggregate

Source: Developed from Developed from Multi-Regional Aggregate Training and Certification Group (2006)

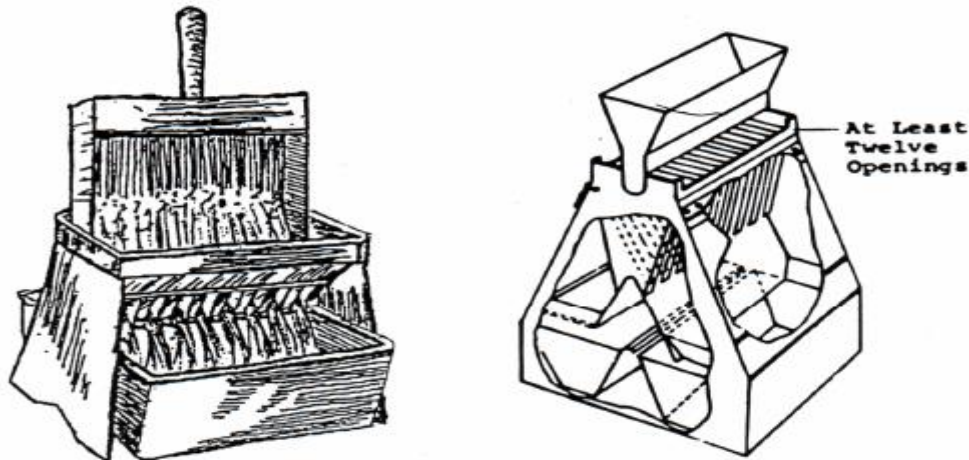

Fig.1-2: Riffle samplers for fine aggregate

Source: Developed from Developed from Multi-Regional Aggregate Training and Certification Group (2006)

2) Sample Reduction - Method B (Quartering)

The quartering method is fairly time intensive and thus is generally used in situations where an adequate mechanical splitter is unavailable. Table 1-3 can be used as outline of when it is appropriate to use the Mechanical Splitter or Quartering methods. Diligence and care is required to ensure that the samples obtained by quartering remain representative of the entire field sample. In order to carry out sample reduction using method B, all of the equipments listed below should be available.

	Drier Than SSD	Wetter Than SSD
Fine Aggregate (FA)	Mechanical Quartering	Quartering
Coarse Aggregate (CA)	Either	Either
Mixture FA/CA	Either	Either

Table 1-3: Outline for appropriate method of reduction for sampling

Source: Washington State Department of Transportation, 2006

a) The apparatus

- Straight-edged scoop.
- Flat-edged shovel or trowel.
- Broom or brush.
- Alternate method only - canvas blanket measuring approximately 2 m by 2.5 m

b) Sample Preparation

- Fine aggregate must be in a moist condition to use Method B - quartering, to reduce the sample. The material should be damp enough to allow it to stand in an almost vertical face.
- Coarse aggregate may be either damp or dry when using Method B. (Method A is the preferred sample reduction method for coarse aggregates).
- Combined aggregates must be in a moist condition to reduce the sample by Method B, again able to stand in an almost vertical face.

c) Reduction Procedure

- Place the original sample on a hard, clean, level surface.
- Mix the material thoroughly by turning the entire sample over with the shovel three times.
- With the last turning, shovel the entire sample into a conical pile by depositing each shovelful on top of the preceding one. Carefully flatten the conical pile to a uniform thickness and diameter by pressing down the apex with the shovel so that each quarter section of the resulting pile will contain the material originally in it. The pile diameter should be approximately four to eight times the thickness.
- Divide the flattened pile into four equal quarters with the shovel or trowel. Remove two diagonally opposite quarters, including all fine material.
- Brush the cleared spaces clean. Successively mix and quarter the remaining material in the same fashion as the original sample.
- Continue this process until the desired quantity is obtained.
- Save the unused portion of the original field sample until all testing is completed in case a retest is needed.

d) Alternative to B method

When the floor surface is uneven, another method which is known as Alternative to B method can be used. In method, the field sample may be placed on a canvas blanket and mixed with a shovel, or by alternatively lifting each corner of the blanket and pulling it over

the sample toward the diagonally opposite corner causing the material to be rolled. Flatten and divide the pile as described in Method B, or if the surface beneath the blanket is too uneven, insert a stick or pipe dividing the pile into two equal parts. Remove the stick leaving a fold in the canvas between the sample halves. Slide the stick under the canvas blanket again at a right angle to the first division and dissecting the two halves of the sample through their centers. Lift the stick evenly from both ends dividing the sample into equal quarters. Remove two diagonal parts including the fine material and clean the area. Successively mix and quarter the remaining material until the desired sample size is obtained.

Figure 1-3 and 1-4 show the procedure to carry out both the Method B and alternative to B method.



Figure 1-3: Method B

Source: Ibid



Figure 1-4: Alternative to B method

e) Common sampling reduction errors

- Failure to obtain a field sample.
- Failure to select proper method for sample reduction based on aggregate moisture content.

- Failure to uniformly distribute the field sample from edge to edge while placing it in the hopper or pan prior to pouring it through the chutes when using a mechanical splitter.
- Failure to, when using a mechanical splitter, control the rate at which the materials are poured through the chutes such that the material is free flowing into the receptacle pans below. This includes using a hopper or straight-edged pan that has a width equal to or slightly less than the overall width of the assembly of chutes.
- Failure to use or set mechanical splitters to meet the applicable requirements for number of chute openings and chute width.
- When using the quartering method or miniature stockpile method, failure to mix the sample thoroughly by turning the entire sample over three times.
- When using the quartering method, failure to brush the cleared spaces clean of fines after removing the two diagonally opposite quarters from the flattened field sample.
- When using the miniature stockpile method, failure to obtain the five (minimum) increments of material from random locations in the miniature stockpile. Do not take all five samples from the same location.

1.7 Tests for aggregates

1.7.1 Introduction

Aggregates are basically deposits, which are formed due to geological processes on their original rock like weathering and erosion, so aggregates shape, size and other properties depend essentially on the different process the rock was exposed to. They are generally occupy about 70 to 80% of the volume of concrete and can therefore be expected to have an important influence on its properties. They are granular materials, derived for the most part from natural rock, crushed stone, or natural gravels and sands, although synthetic materials such as slags and expanded clay or shale, for example, are used to some extent, mostly in lightweight concretes. In addition to their use as economical filler, aggregates generally provide concrete with better dimensional stability and wear resistance.

Aggregates are the inert particles that are bound together by the cementing agent (such as Portland cement) to form a mortar or a concrete. Mortar is a mixture of fine aggregate, a cementing material, and water. A mixture of only cement and water is referred to as “neat cement.” Concrete is composed of the ingredients of mortar plus coarse aggregates. The boundary size definition of fine aggregates is one that passes a 4.75 mm (#4) sieve. Coarse aggregate particle sizes are those that are retained on a 4.75 mm (#4) sieve opening. There is no real maximum size aggregate, but in most concretes for pavements and structures the upper limit is usually 5 cm (2 in.), but may be larger. Coarse aggregates are obtained from gravel or crushed stone, blast furnace slag, or recycled concrete. Trap rocks, granite, limestone, and sandstones are satisfactory for crushed stone. Fine aggregates are derived from the same sources except that in the place of gravel, naturally occurring sand is used. All aggregates should be composed of hard particles and free of injurious amounts of clay, loam, and vegetable matter. The principal characteristics of aggregates that affect the strength, durability, and workability of a concrete are cleanness, grading, hardness, and shape. Usually the aggregates are stronger than the concrete from which they are made. A coating of dirt or dust on the aggregate will reduce the strength of concrete because it prevents the particles from properly bonding to the mortar. A well-graded

aggregate mix is essential to obtaining an economical concrete of good quality. If poorly graded, even clean, sound aggregates will require excessive water for workability, resulting in lower strength, or the mix will require an excessive amount of cement to develop a given strength.

- **Quality:** aggregates are inert materials such as sand, pebbles, gravel, crushed stones and industrial by-products form some kind of aggregates which is light aggregates used to produce lightweight concrete to use it in special cases.
- **Classification:** it is convenient to divide aggregate into coarse and fine fractions. The coarse aggregate fraction is that retained on the No. 4 sieve (4.75-mm opening), while the fine aggregate fraction is that passing the No. 4 sieve (4.75-mm opening). Therefore, aggregates are a mixture of both coarse and fine fractions as it comes from the pit, riverbed, foreshore, quarry or crushing plants. Coarse aggregates may consist of natural picked gravel, crushed gravel and crushed stones. The most commonly used of fine aggregate is sand.
- **Properties:** aggregates should be hard, durable, strong and free from silt, organic matter and other undesirable impurities to use it in producing concretes and in construction. Soft, porous rock can limit strength and wear resistance; it may also break down during mixing and adversely affect workability by increasing the amount of fines. Rocks that tend to fracture easily along specific planes can also limit strength and wear resistance. Therefore, it is best to avoid aggregates that contain a significant proportion of weak or friable materials, or to remove these. Aggregates should also be free of impurities: silt, clay, dirt, or organic matter. If these materials coat the surfaces of the aggregate, they will interfere with the cement-aggregate bond. Silt, clay, and other fine materials will also increase the water requirements of the concrete; and organic matter may interfere with cement hydration.
- **Treatment:** if the aggregate available at the laboratory is not clean, it should be washed before being used. In addition, if the available aggregates are not properly graded, it should be screened and divide with hand or other mechanical methods to get the right proportions of each size of the aggregates. Such methods are mentioned in the pervious sections.
- **Storage:** aggregates should not store on dusty, muddy and grassy spots. Aggregates should be stored in stockpiles in individual units, which are not larger than a truckload, and in suitable layers; to prevent segregation. Furthermore, they should not run down slopes.

The final choice of the source of supply of any aggregate is not entirely based on the results achieved by performing tests in the laboratory. However, the degree of accuracy of the results attained in the lab is sufficient for the sample to decide whether it is acceptable commercially or not. Moreover, several experiments are applied to test for the abrasion, durability and right

grading-proportions of the aggregates. The experiments, which were performed in the concrete lab at Birzeit University, are included Sieve analysis of fine and coarse aggregates, Specific gravity and absorption of coarse and fine aggregates. All of these experiments will be studied in details in this manual.

Before studying the experiments that are usually carried out through the ENCE 315 “First Concrete Lab”, the following definitions should be mentioned. Some of these definitions are repeated for the convenience of the reader.

- Nominal Maximum Size - The largest sieve size listed in the applicable specification, upon which any material may be retained.
- Saturated Surface Dry (SSD) - An aggregate is considered to be in a saturated surface dry condition when there is no free moisture present but the aggregate is in a nonabsorbent state. In other words, the aggregate has all the moisture it can absorb and surface of the aggregate is dry.
- Air Dry - When the aggregate appears to be dry but still has some absorbed moisture in its pore structure.
- Fine Aggregate - Aggregate which has a nominal maximum size of the 4.75 mm (No. 4) sieve or smaller.
- Coarse Aggregate - Aggregate which is predominately larger than the 4.75 mm (No. 4) sieve.
- Combined Aggregate - Aggregate which has a blend of both coarse and fine particles.

The ASTM specification for the grading and quality of aggregates for normal weight concrete is defined by ASTM Designation: C 33. There are seven standard sieve openings for fine aggregate and up to 13 sieve sizes for coarse aggregates. The grading requirements are shown in Table 1-4 and figure 1-5.

Sieve Size (Specification E 11)	Percent Passing
9.5 mm (3/8 in.)	100
4.75 mm (No.4)	95–100
2.36 mm (No.8)	80–100
1.16 mm (No.16)	50–85
600 m (No.30)	25–60
300 m (No.50)	10–30
150 m (No.100)	2–10

Table 1-4: Grading Requirement for Fine Aggregates from ASTM Designation: C 33

Source: Kett, 2000

Nominal Sieve Size	Amounts Finer Than for Sieve Size, Weight Percent												
	100 mm (4 in.)	90 mm (3.5 in.)	75 mm (3 in.)	63 mm (2.5 in.)	50 mm (2 in.)	37.5 mm (1.5 in.)	25 mm (1 in.)	19 mm (0.75 in.)	12.5 mm (0.5 in.)	9.5 mm (3/8 in.)	4.75 mm (No.4)	2.36 mm (No.8)	1.18 mm (No.16)
37.5-90 mm (1.5-3.5 in.)	100	90-100		25-60		0-15		0-5					
37.5-63 mm (1.5-2.5 in.)			100	90-100	35-70	0-15		0-5					
25-50 mm (1-2 in.)				100	90-100	35-70	0-15		0-5				
4.75-50 mm (No.4-2 in.)				100	95-100		35-70		10-30		0-5		
19-37.5 mm (0.75-1.5 in.)					100	90-100	20-55	0-15		0-5			
4.75-37.5 mm (No.4-1.5 in.)					100	95-100		35-70		10-30	0-5		
12.5-25 mm (0.5-1 in.)						100	90-100	20-55	0-10	0-5			
9.5-25 mm (0.375-1 in.)						100	90-100	40-85	10-40	0-15	0-5		
4.75-25 mm (No.4-1 in.)						100	95-100		25-60		0-10	0-5	
9.5-19 mm (.375-.75 in.)							100	90-100	20-55	0-15	0-5		
4.75-19 mm (No.4-.75 in.)							100	90-100		20-55	0-10	0-5	
4.75-12.5 mm (No.4-0.5 in.)								100	90-100	40-70	0-15	0-5	
2.36-9.5 mm (No.8-.375 in.)									100	85-100	10-30	0-10	0-5

Fig.1-5: Grading Requirements for Coarse Aggregates from ASTM Designation: C 33

Source: Ibid.

1.8 Experiment 1: Total Moisture Content of Aggregate by drying (Developed from AASHTO T 255)





• Introduction

In order to ensure the aggregate performs as intended for the specific use, a variety of tests must be performed on the aggregate. One such test is the moisture content of an aggregate. The internal structure of an aggregate particle is made up of solid matter and voids that may or may not contain water. The moisture content in aggregate needs to be determined to identify aggregate absorption, a base to determine maximum allowable water concern for Portland cement concrete, moisture restrictions for hot mix asphalt, and determination of density. Basically, a known amount of material is taken, heated to drive off the moisture and the percentage moisture determined. Several methods of heating can be used, including:

- Hot plate
- Oven
- Microwave oven

The moisture conditions of aggregate are shown in Figure 1-6 (a). They are designated as

- Oven dry- fully absorbent
- Air dry- dry at the particle surface but containing some interior moisture, thus still somewhat absorbent
- Saturated surface dry (SSD)- neither absorbing water from nor contributing water to the concrete mixture
- Damp or wet- containing an excess of moisture on the surface (free water)

State	Oven dry	Air dry	Saturated, surface dry	Damp or wet
				
Total moisture	None	Less than potential absorption	Equal to potential absorption	Greater than absorption

Moisture conditions of aggregates

(a)

Figure 1-6: Aggregate in various moisture states**Source:** Mehta and Monteiro, 2006

- **Apparatus**

- Balance, general purpose
- Source of heat for Aggregate: a ventilated oven capable of maintaining a temperature of $110\pm 5^{\circ}\text{C}$ ($230\pm 9^{\circ}\text{F}$)
- Sample container for Aggregate: Should be suitable for method selected, not affected by heat and nonmetallic if using a microwave.
- Stirrer to mix sample while drying to assist in water evaporation

- **Procedure**

- Select the proper sample size based on the following chart (Table 1-5).

Aggregate Moisture Content Sample Sizes	
Nominal Maximum size mm (in.)	Minimum Sample Mass
4.75 (#4) or smaller	0.5 kg (1.1lbs.)
9.5 (3/8)	1.5 kg (3.3 lbs.)
12.5 (1/2)	2 kg (4.4 lbs.)
19 (3/4)	3 kg (6.6 lbs.)
25 (1)	4 kg (8.8 lbs.)
37.5 (1 1/2)	6 kg (13.2 lbs.)
50 (2)	8 kg (17.6 lbs.)

Table 1-5: selecting proper sample size for various aggregates

- Obtain the sample and protect it from moisture loss during transport to the testing facility. An airtight container or plastic bag is best for this purpose.
- Weigh the sample to the nearest 0.1% and record this mass as the original mass, W, of the sample.
- Dry the sample in a suitable container on a selected source of heat until the sample shows less than 0.1% change in mass over subsequent weighing. In the event that you encounter material with a nominal size aggregate over 37.5mm (1 1/2"), be aware that larger aggregate particles require longer drying times.
- Record the mass of the dried aggregate (after it has cooled sufficiently so as not to damage the scale) to the nearest 0.1% as the dry mass, D.

- **The source for heating**

Oven: The most common is probably an oven regulated at $110\pm 5^{\circ}\text{C}$ ($230\pm 9^{\circ}\text{F}$). An oven is a good choice when time is not of the essence. Samples dried in the oven, depending on the type of container you use and the moisture content of the sample, can take anywhere from one to several hours to dry to a constant mass. The benefit of using an oven is that it is very

unlikely that sensitive aggregate will overheat and fracture. If you are working with sensitive aggregates, then, an oven is probably your best choice. If you are working with a material that contains soils or highly absorbent items (such as clay), they may be affected by excessive moisture within the oven as other items are drying. Check the oven's evaporation rate in accordance to optimize drying time.

- **Calculation**

The calculation for moisture content (P) is as follows: Multiply the difference of the original mass (W) and dry mass (D) times 100 and divide that result by the dry mass (D).

$$P = 100(W - D)/D$$

Where: P = moisture content of sample, %

W = original (wet) mass of sample, g

D = dry mass of sample, g

- **Useful Notes:**

- Avoid heating the aggregate sample so fast that steam causes the aggregate to break or spatter.
- Surface moisture is determined by subtracting the percent of absorption from the total percent of evaporable moisture.

- **Common sources of error**

- Overheating
- Insufficient sample size
- Loss of material when stirring
- Predrying the sample
- Use of a volatile
- Performing the calculation

1.9 Experiment 2: Sieve analysis of coarse and fine aggregates (Developed from AASHTO T 27/ T 11 and ASTM Designation: C 136 and 117)

- **Introduction**

Grading is the distribution of particles of a granular material among various size ranges, usually expressed in terms of cumulative percentage larger or smaller than each of a series of sizes of sieve openings, or the percentage between certain ranges of sieve openings. There are several reasons for specifying grading limits and maximum aggregate size; the most important is their influence on workability and cost. For example, very coarse sands produce harsh and unworkable concrete mixtures, and very fine sands increase the water requirement (therefore, the cement requirement for a given water-cement ratio) and are uneconomical. Aggregates that do not have a large deficiency or excess of any particular size produce the most workable and economical concrete mixtures.

The maximum size of aggregate is conventionally designated by the sieve size on which 15 percent or more particles are retained. In general, the larger the maximum aggregate size, the smaller will be the surface area per unit volume which has to be covered by the cement paste of a given water-cement ratio. Since the price of cement may be 10 to 15 times as much as

the price of aggregate, any action that saves cement without reducing the strength and workability of concrete can result in significant economic benefit. In addition to cost economy, there are other factors that govern the choice of maximum aggregate size for a concrete mixture. According to one rule of thumb used in the construction industry, the maximum aggregate size should not be larger than one-fifth of the narrowest dimension of the form in which the concrete is to be placed; also, it should not be larger than three-fourths of the maximum clear distance between the reinforcing bars. As large particles tend to produce more micro cracks in the interfacial transition zone between the coarse aggregate and cement paste, with high-strength concrete mixtures the maximum aggregate size is generally limited to 19 mm.

Similarly, aggregate grading has also considerable effect on the cement paste requirement of a concrete mixture. The effect of aggregate packing with particles of varying sizes is demonstrated in Fig. 7-6a. One beaker is filled with 25-mm particles of relatively uniform size and shape; a second beaker is filled with a mixture of 25- and 9-mm particles. Below each beaker is a graduated cylinder holding the amount of water required to fill the voids in beaker above. It is evident that by combining two different aggregate sizes, the void content is decreased. If particles of several more sizes smaller than 9 mm are added to the 25-mm and 9-mm aggregate mixture, a further reduction in the void content will result. In practice, low void contents are achieved by using smoothly graded coarse aggregates with suitable proportions of graded sand.

The data show test results in which as low as 21 percent void content was obtained when 40 percent sand was mixed with a well-graded, 4.75 to 37 mm (No. 4 to 11/2) gravel. From standpoint of obtaining high workability of concrete mixtures, it is well known that the smallest percentage of voids corresponding to the greatest dry-rodded density with given aggregates is not the most satisfactory; the volume of cement paste to fill the voids should be somewhat more.

In practice, an empirical factor called the fineness modulus is often used as an index of the fineness of aggregate. The fineness modulus is computed from screen analysis data by adding the cumulative percentages of aggregate retained on each of a specified series of sieves, and dividing the sum by 100. The sieves used for determining the fineness modulus are: No. 100 (150 μm), No. 50 (300 μm), No. 30 (600 μm), No. 16 (1.18 mm), No. 8 (2.36 mm), No. 4 (4.75 mm), 3/8 in. (9.5 mm), 3/4 in. (19 mm), 1 1/2 in. (37.5 mm), and larger, increasing in the ratio of 2 to 1. Examples of the method for determining the fineness modulus of fine aggregates from three different sources are shown by the tabulated data in Fig. 1-7, together with a typical grading curve. It may be noted that the higher the fineness modulus, the coarser the aggregate.

The basic sieve analysis test procedures are the same for all types. Some test variations are needed to avoid overloading of sieves during the sieving operations. Also, this test method alone is not recommended when an accurate determination of the amount of material smaller than the 75 μm (#200) sieve is specified.

Sieve sizes commonly used to test a coarse aggregate are:

37.5mm (1½ in.); 25.0mm (1 in.); 19.0mm (¾ in.); 16mm (⅝ in.); 12.5mm (½ in.); 9.5mm (⅜ in.); 4.75 mm (#4); and 2.36mm (#8).

Sieve sizes commonly used to test a fine aggregate are:

4.75mm (#4); 2.36mm (#8); 1.18mm (#16); 600µm (#30); 300µm (#50); 150µm (#100); and 75µm (#200).

Date	January 14, 2005			January 14, 2005			January 14, 2005		
Source	A (fine sand for blending)			B (Concrete sand)			C (Concrete sand)		
Sample wt.	456 g			450 g			456 g		
Sieve size	Weight retained	Retained, %		Weight retained	Retained, %		Weight retained	Retained, %	
		Individual	Cumulative		Individual	Cumulative		Individual	Cumulative
No. 4	0	0	0	0	0	0	0	0	0
8	0	0	0	40.5	9.1	9	42.1	9.2	9
16	2.8	0.6	1	85.0	19.1	28	137.0	30.2	39
30	10.1	2.2	3	94.5	21.0	49	112.1	24.7	64
50	259.2	56.9	60	135.9	30.2	79	84.9	18.7	83
100	173.1	38.0	98	77.0	17.1	96	48.8	10.8	94
200	5.6	1.2	99	13.5	3.0	99	29.1	6.4	100
Fan	3.3	0.7	100	2.1	0.5	100	1.0	0.2	100
Total	454.1	F.M.	1.62	449.5	F.M.	2.61	455.0	F.M.	2.89

(a)

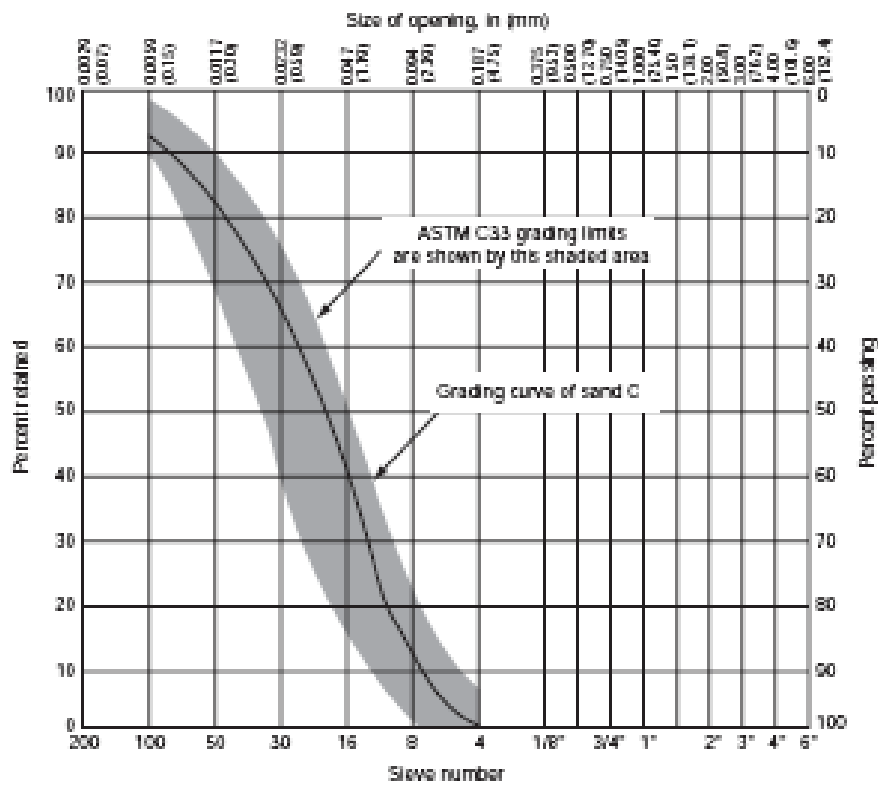

(b)

Figure 1-7:(a) Determination of the fineness modulus from sieve analysis data; (b) typical grading curve for sand with ASTM C 33 grading limits.

Source: Mehta and Monteiro, 2006

- **Apparatus**

- Balance – Accurate to 0.1 percent of the sample to be tested.
- Sieves – Mounted on substantial frames and constructed to prevent loss of material during sieving. Sieves with openings larger than 125mm (5 in.) may vary ± 2 percent in average openings and have a nominal wire diameter of 8.0mm (5/16 in.) or larger.
- Oven (or drying stove/hot plate) – An oven of appropriate size capable of maintaining a uniform temperature of $110^{\circ}\pm 5^{\circ}\text{C}$ ($230^{\circ}\pm 9^{\circ}\text{F}$). A drying stove or hot plate may be used as long as the temperature is controlled to prevent popping and splattering of the sample, and the temperature does not cause fracturing or chemical breakdown of the aggregate.
- Mechanical Sieve Shaker – A mechanical sieve shaker, if used shall impart a vertical, or lateral and vertical, motion to the sieve(s). This motion causes the aggregate particles to bounce and turn during sieving. The action should allow sieving to completion, as described in the test procedures, within a reasonable amount of time.
- Fiber-bristle Sieve Cleaning Brush – To aid in cleaning the finer-meshed sieves.

- **Sample preparation**

A field sample of the aggregate to be tested must be obtained by an appropriate method. Reduce the field sample to the required sample size for sieve analysis by following an approved method. Recommended sample sizes are in the following table 1-6.

Sample Sizes for Sieve Analysis Coarse Aggregate	
Nominal Maximum Size Square Openings mm (in.)	Minimum Mass of Test Sample kg (lb.)
9.5 ($\frac{3}{8}$)	1 (2)
12.5 ($\frac{1}{2}$)	2 (4)
19.0 ($\frac{3}{4}$)	5 (11)
25.0 (1)	10 (22)
37.5 ($1\frac{1}{2}$)	15 (33)
50.0 (2)	20 (44)
63.0 ($2\frac{1}{2}$)	35 (77)
75.0 (3)	60 (130)
90.0 ($3\frac{1}{2}$)	100 (220)
100.0 (4)	150 (330)
112.0 ($4\frac{1}{2}$)	200 (440)
125.0 (5)	300 (660)
150.0 (6)	500 (1100)

- **Sample Sizes for Sieve Analysis Fine Aggregate**

Aggregate samples with at least 95% passing the 2.36mm (#8) sieve need a minimum dry sample mass (weight) of 100 grams. Aggregate samples with at least 85% passing the 4.75mm (#4) sieve need a minimum dry sample mass (weight) of 500 grams.

- **Test Procedure**

- Dry the sample to a constant mass (weight) in the oven at a temperature of $110^{\circ}\pm 5^{\circ}\text{C}$ ($230^{\circ}\pm 9^{\circ}\text{F}$). A drying stove or hot plate may be used as long as the temperature is controlled to prevent popping and splattering of the sample, and the temperature does not cause fracturing or chemical breakdown of the aggregate. If aggregate fracturing happens during the drying process, throw out the sample and start a new one.
- When the sieve analysis is to be performed on coarse aggregate with a nominal maximum size of 12.5mm ($\frac{1}{2}$ in.) or larger, drying to a constant mass (weight) may not be needed if the material contains only a minimal amount of material passing the 4.75mm (#4) sieve and does not have highly absorptive particles (such as lightweight aggregates). The sample should be in an “air-dry” condition before testing (no visible moisture).
- When the sample is cool to a point safe to handle, weigh the sample to the nearest 0.1 percent based on the original dry mass (i.e. a 500 gram minimum sample mass must be weighed to the nearest 0.5 gram: 1000 to the nearest 1.0 gram, etc. – refer to the sample size charts in sample preparation section).
- The sample is now ready to be screened. Use the number of sieves needed to determine specification compliance. Additional sieves may be desirable to provide other information such as Fineness Modulus, or to aid in preventing the overload of consecutively smaller sieves.
- The amount of material on any given sieve must be limited to allow all particles the opportunity to pass through the sieve openings a number of times during the operation. The mass (weight) retained on sieves with openings smaller than 4.75mm (#4) must not exceed 6kg/m^2 (4 g/in.^2) of sieving surface. This amounts to 194 grams on a 203mm (8 in.) diameter sieve and approximately 450 gram on a 305mm (12 in.) diameter sieve. For sieves with openings 4.75mm (#4) and larger, the mass (weight) in kg/m^2 of sieving surface shall not exceed the product of 2.5 x (the sieve opening in mm). The mass (weight) of the sample must never be so large as to cause any deformation of the sieve cloth.
- To prevent overloading a sieve, place a sieve with larger openings above the given sieve when practical, or sieve the sample in smaller increments
- When using a mechanical sieve shaker nest the sieves, one on top of the next. The screen with the largest openings goes on top with decreasing opening sizes to the smallest, followed by the pan. Place the test sample, or portion of the sample if it is to be sieved in more than one increment, on the top sieve. Start the mechanical shaker, being sure the nest of sieves is properly secured in the shaker. The length of sieving time must be sufficient to allow for sieving to completion.
- When hand sieving a sample, a nest of sieves may be used, or it may be easier to sieve the sample one screen at a time. When using a nest of sieves, care must be taken to prevent material loss

- After sieving, aggregate trapped in the sieve mesh should be removed. Coarse aggregate sieves are cleaned by gently working the entrapped aggregates from the mesh by hand. Excessive banging and dropping may damage the sieve. A wire brush may be used on finer mesh sieves through the 0.60mm (#30) sieve. A fiber – bristle brush and gentle tapping of the sieve should be used to clean sieves smaller than the 0.60mm (#30) sieve.
 - Whether hand sieving or using a mechanical shaker, each sample increment must be sieved to completion.
 - For round sieves with openings 4.75mm (#4) and smaller, a check for sieving to completion by hand is to be performed as follows: Hold the individual round sieve, with a cover and snug fitting catch pan, in one hand and slightly tilted. Strike the sieve sharply with an upward motion against the heel of the other hand at an approximate speed of 150 times per minute. Turn the sieve about one-sixth revolution every 25 strokes.
 - For sizes larger than 4.75 (#4), check for sieving to completion with a single layer of material on the sieve surface.
 - Weigh any material passing the sieve in question and divide that mass (weight) by the original dry mass (weight) of the sample (x100) to determine the percent. If this percentage is greater than 0.5, longer sieving times or smaller increments may be needed on future samples.
 - Experience and multiple testing of the material will help the technician in determining the amount of material and length of sieving time needed to achieve sieving to completion. Excessive sieving times, especially when testing more abrasive aggregates, may cause the breakdown of some particles, altering the true gradation of the material. This must be avoided.
 - Each sample increment is weighed to at least the required accuracy and the mass (weight) is recorded as mass (weight) retained on the individual sieve. Each increment should be saved individually until the entire test procedure is completed.
 - The amount of material placed into the sieves must be the same as the total of the material retained in the sieves and the pan after sieving, within a tolerance of 0.3 percent. To check this, add the retained masses (weights) together, including the mass (weight) of the pan. Do not include the amount of washing loss of the sample if it has been tested before sieving. Divide this total by the dry mass (weight) of the sample before sieving (after washing if applicable) x 100. This result must be within 0.3 percent. If this result is over 0.3, the technician should check the sieves for any excessive retained material. Reweigh each increment after assuring the pan tare is correct. If the error cannot be found, the test result must not be used to accept or reject the material being tested and the test must be repeated with a new sample.
- **Calculations**
 - The percent of material retained on each sieve is calculated by dividing the mass (weight) retained on each sieve by the mass (weight) of the original dry sample, (before washing if applicable). This result is then multiplied by 100 to convert to percent and recorded to the nearest 0.1 percent.

- This column should, when added, equal 100 percent. Often, due to rounding, this column will not equal 100 percent exactly. The difference should be prorated to the sieves containing the larger amounts of material. If the total is not within 0.3 percent, an error in calculations may have been made and should be checked and corrected.
 - The percentage passing each sieve may now be determined by consecutively subtracting the percent retained, starting with the first sieve used which has no material retained (100 percent passing).
 - The percent passing the last sieve tested must equal the last result calculated in the percent retained column or subtraction error has occurred. This would be the 75 μ m (#200) sieve if the sample were tested.
 - The Fineness Modulus, when required, may now be calculated by adding the percent retained on each of the following sieves larger than the 75 μ m (#200) sieve and dividing that sum by 100: 150 μ m (#100); 300 μ m (#50); 600 μ m (#30); 1.18mm (#16); 2.36mm (#8); 4.75mm (#4); 9.5mm ($\frac{3}{8}$ in.); 19.0mm ($\frac{3}{4}$ in.); 37.5mm (1 $\frac{1}{2}$ in.); and larger, (i.e. doubling the previous sieve size).
- **Reporting**
 - Depending upon specification requirements the sieve analysis test results are reported as (1) percent passing each sieve, (2) percent retained on each sieve, (3) percent retained between consecutive sieves.
 - The percentages are to be reported to the nearest whole number, except when the percent passing the 75 μ m (#200) sieve is less than 10.0. This result is reported to the nearest 0.1 percent. The fineness modulus is reported to the nearest 0.01 percent.

• Data sheet

Sample Number				Sample Number			
Sieve Size	Weight Retained (g)	% Retained	% Passing	Sieve Size	Weight Retained (g)	% Retained	% Passing
2 in.				2 in.			
1 1/2 in.				1 1/2 in.			
1 in.				1 in.			
3/4 in.				3/4 in.			
1/2 in.				1/2 in.			
3/8 in.				3/8 in.			
#4				#4			
#8				#8			
#16				#16			
#30				#30			
#50				#50			
#100				#100			
#200				#200			
Pan				Pan			
Total				Total			
a. Wt. of sample (g) -				a. Wt. of sample (g) -			
b. Wt. of sample after washing (g) -				b. Wt. of sample after washing (g) -			
c. Loss in washing, (a - b) (g) -				c. Loss in washing, (a - b) (g) -			
d. Pan from dry sieve (g) -				d. Pan from dry sieve (g) -			
Total: 200, (c + d) (g) -				Total: 200, (c + d) (g) -			

Figure 1-8: Wash and Dry Sieve Analysis — Sieve Analysis for Fine and Coarse Aggregates (ASTM C136) and Mineral Aggregates by Washing (ASTM C117)

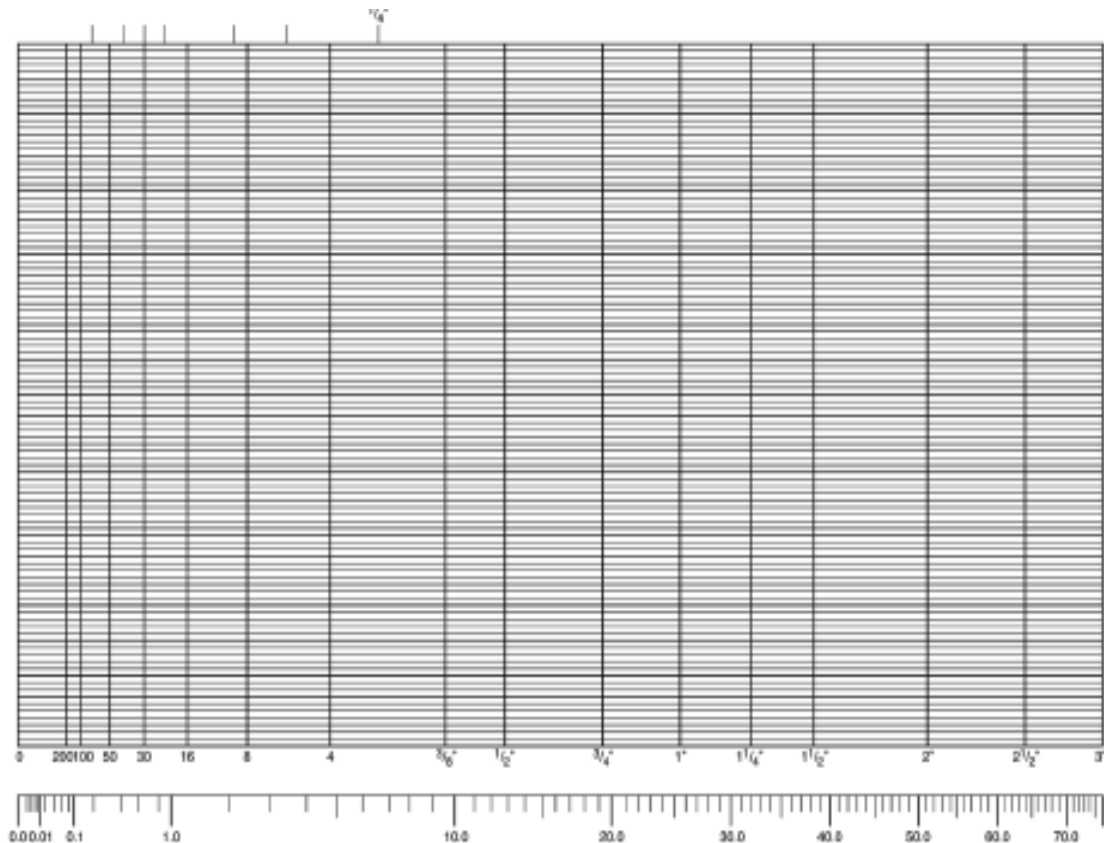

Figure 1-9: Millimeter gradation chart

- **Common testing errors**

1. Improper sample size
2. Overloading of sieves
3. Loss of material while performing test procedures
4. Insufficient sieve cleaning
5. Using damaged sieves (e.g. holes in screen, cracked, etc.)
6. Not sieving to completion
7. Using a balance not accurate enough for the sample to be tested
8. Not drying sample to a constant weight before test procedure

1.10 Experiment 3: Specific gravity for Coarse and fine aggregates (Developed from ASTM Designations: C 127 and C 128)

- **Purpose**

Determine the bulk and apparent specific gravities and absorption of coarse and fine aggregates. Absorption is the process by which water is drawn into and tends to fill the permeable pores in a porous solid body.

• Introduction

As previously mentioned, the aim of this experiment is to find the specific gravity for both fine and coarse aggregates, as well as to find the absorption. Specific Gravity is the ratio of the mass of a given volume of aggregate to the mass of an equal volume of water. Water, at a temperature of 23° C (73.4° F) has a specific gravity of "1" or 1 000 kg per cubic meter. Specific Gravity is important for several reasons. Some deleterious particles are lighter than the "good" aggregates. Tracking specific gravity can sometimes indicate a change of material or possible contamination. Differences in specific gravity can be used to separate the bad particles from the good using a heavy media liquid.

In Portland Cement Concrete the specific gravity of the aggregate is employed in calculating the percentage of voids and the solid volume of aggregates in computations of yield. The absorption is important in determining the net water-cement ratio in the concrete mix. Knowing the specific gravity of aggregates is also critical to the construction of water filtration systems, slope stabilization projects, railway bedding and many other applications.

This method determines the specific gravity of coarse and fine aggregates that have been soaked for a period of 15-19 hours. There are four determinations that may be made from this procedure. They are as follows:

1. Bulk specific Gravity (Gsb) (also known as Bulk Dry Specific Gravity)

The ratio of the mass in air of a unit volume of aggregate at a stated temperature to the mass in air of an equal volume of gas-free distilled water at a stated temperature (Figure1-10). This unit volume of aggregate is composed of the solid particles, including the permeable and impermeable voids (internal pore system), but does not include the voids between the aggregate particles.

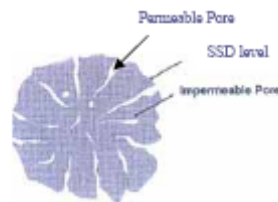

Figure 1-10:Diagram of bulk specific gravity

Where:

A = Oven dry mass

B = SSD mass in air

C = SSD Mass in water

The formula for Gsb is as follows:

$$Gsb = A / (B - C) \dots \dots \dots (1)$$

2. Bulk SSD Specific Gravitu (Gsb SSD)

The ratio of the mass in air of a unit volume of aggregate, INCLUDING the mass of water within the voids filled to the extent achieved by submerging in water for

approximately 15 hours, to the mass in air of an equal volume of gas-free distilled water at a stated temperature (Figure 1-11).

The formula for $G_{sb} SSD = B / (B - C)$

Where:

A = Oven dry mass

B = SSD mass in air

C = SSD Mass in water



Fig.1-11: Diagram of Bulk SSD specific gravity

3. Apparent Specific Gravity (G_{sa})

This ratio of the mass in air of a unit volume of the impermeable portion of aggregate (does not include the permeable pores in aggregate) to the mass in air of an equal volume of gas-free distilled water at a state temperature (Figure 1-12).

The formula for $G_{sa} = A / (A - C)$

Where:

A = Oven dry mass

B = SSD mass in air

C = SSD Mass in water

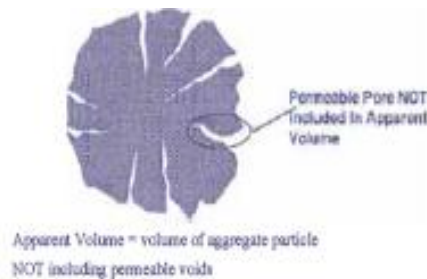

Figure 1-12: Diagram of Apparent specific gravity

4. Absorption (% Abs.)

The increase in mass of aggregate due to water in the pores of the material, but not including water adhering to the outside surface of the particles (Figure 1-13.)

$\% Abs. = [(B - A) / A] \times 100$

Where: A = Oven dry mass

B = SSD mass in air

C = SSD Mass in water

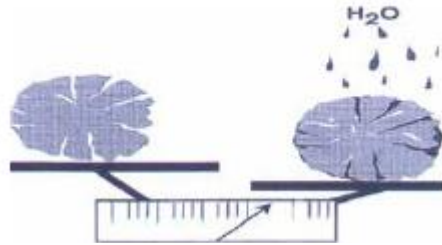

Figure 1-13: Increase in mass due to absorption of water

- **Equipment and Materials**

- Balance with a capacity of at least 2 kg with an accuracy to 0.1 grams
- Wire basket of 3.35 mm (No.6) or finer mesh with about a 1 liter capacity
- Six 500 ml pycnometers
- Conical sheet metal brass mold 40 mm (1 1/2 in.) in diameter at the top, 90 mm (3 1/2 in.) in diameter at the bottom, and 75 mm (3 in.) in height
- Metal tamping rod with a flat circular tamping face 25 mm (1 in.) in diameter, weighing 340 grams (12 oz)
- Suitable balance and apparatus for suspending sample in water
- Large splitter for coarse aggregate and a small splitter for fine aggregate
- 5 kg of coarse aggregates where the nominal maximum size is 37.5 mm (1 1/2 in.) or less and all material is retained on the 4.75 mm (No.4) sieve
- 3 kg of fine aggregates, all particles passing the 4.75 mm (No.4) sieve

- **Test procedure**

- 1. Coarse Aggregate**

- Select by quartering or use of a sample splitter approximately 5 kg of aggregate. Reject all material passing a No. 4 sieve.
- Thoroughly wash the sample to remove all dust or other coatings from the particles.
- Dry the sample to a constant weight at a temperature of 100 to 110°C (212 to 230°F). Cool at room temperature for about 15 min. and then immerse in water at room temperature for approximately 30 min.
- Remove sample from water and wipe the particles until all surface films are removed. Weigh the sample in this saturated surface dry condition to the nearest 0.5 g.
- Immediately after weighing, place the sample in a wire basket, suspend in water, and obtain the buoyant weight.
- Dry the sample to a constant weight at a temperature of 100 to 110°C (212° to 230°F), cool in room temperature for at least 30 min. and weigh.
- Computations
 - A = Weight of oven-dry sample in air (g)
 - B = Weight of saturated-surface-dry sample in air (g)
 - C = Weight of saturated sample in water (g)

$$\text{Bulk specific gravity (oven-dry)} = \frac{A}{B - C}$$

$$\text{Bulk specific gravity (SSD)} = \frac{B}{B - C}$$

$$\text{Apparent specific gravity} = \frac{A}{A - C}$$

$$\text{Absorption in percent} = \frac{(B - A) \times 100}{A}$$

2. Fine Aggregate

- Obtain by sample splitting or quartering 3000 grams of aggregate, including equal quantities of all fractions.
- Dry to a constant weight at a temperature of 100 to 110°C (212 to 230°F).
- Allow to cool and cover with water for about 30 min.
- Remove excess water and spread on a flat surface. Expose to a gentle moving flame until test sample approaches a free-flowing condition.
- Place a portion of the fine aggregate sample loosely into the mold. Tamp lightly 25 times and lift the mold vertically. If surface moisture is present, the fine aggregate will maintain its molded shape. Continue drying and testing until upon removal of the mold, the aggregate slumps slightly. This indicates that the saturated, surface-dry condition has been reached.
- Immediately introduce into the pycnometer 500.0 g of the fine aggregate. Fill the pycnometer almost to capacity and eliminate the air bubbles by agitation. Add water until the bottom of the meniscus is at the 500 cc line, etched on the pycnometer. Determine the total weight of the flask, including the sample, and the water.
- Carefully remove the fine aggregate and dry to a constant weight of 100 to 110°C (212 to 230°F) and cool for at least 30 min. and weigh.
- Computations
 - A = Weight of oven-dry sample in air (g)
 - B = Weight of pycnometer filled with water (g)
 - C = Weight of pycnometer with sample in water (g)

$$\text{Bulk specific gravity (oven-dry)} = \frac{A}{B + 500 - C}$$

$$\text{Apparent specific gravity} = \frac{A}{B - C + A}$$

$$\text{Bulk specific gravity (SSD condition)} = \frac{500}{B + 500 - C}$$

$$\text{Absorption, percent} = \frac{(500 - A) \times 100}{A}$$

3. Special Instructions

- Determine the specific gravities for three samples of both the coarse and fine aggregates. Test the fourth sample, if necessary, in order to obtain three sets of

results that vary from each other by no more than 2%. If these precisions are not met, rerun the entire test.

- Using the correct specific gravity is important in the design of a Portland cement concrete mix. The particular specific gravity used must be consistent with the moisture condition of the aggregates being batched, whether on an oven dry or a saturated surface dry condition (SSD). Either specific gravity may be used. In an oven-dry condition the aggregates do not possess any absorbed or surface water. In an SSD condition, the water permeable voids of the aggregates are filled with water but no additional free water is present.

- **Explanation of Computations and Data Sheets**

- Computations were explained separately under Test Procedure for both the coarse and fine aggregates.
- Data sheet (specific gravity data sheet) for both the fine and course aggregates the last value obtained in the laboratory will be (A) the weight of the oven-dry sample. Once SSD condition is obtained and weighed, value (C) is determined, which is in effect a measure of buoyancy. In the case of the coarse aggregate, (C) is obtained directly. To get the value (A), the aggregates are placed in an oven and dried to a constant weight. The four values, bulk (dry and SSD), apparent, effective, and absorption are then computed for each sample. Based upon the results, a decision needs to be made as whether or not to test the fourth sample for either or both of the aggregates. The final step in determining the accepted results is by averaging the values of those samples that fall within the guideline criteria as explained in (C). These values will then be used to compute the various mix design computations. It is for this reason that obtaining accurate specific gravities is so important. Do not hesitate to redo the entire procedure if the results are questionable.

Coarse Aggregates — ASTM Designation: C 127				
Passing _____ Sieve and Retained on _____ Sieve	Sample 1	Sample 2	Sample 3	Sample 4
(A) Wt. oven-dry sample (g)				
(B) Wt. SSD sample (g)				
(C) Wt. saturated sample in water (g)				
Bulk specific gravity				
Apparent specific gravity				
Effective specific gravity				
Absorption (%)				
Average values: bulk sp. gravity = ; apparent sp. gravity = ; effective sp. gravity = ; absorption = .				
Fine Aggregates — ASTM Designation: C 128				
(A) Wt. oven-dry sample (g)				
(B) Wt. pycnometer + water to calibration mark (g)				
(C) Pycnometer + water + sample to calibration mark (g)				
Bulk specific gravity				
Apparent specific gravity				
Effective specific gravity				
Absorption (%)				
Average values: bulk sp. gravity = ; apparent sp. gravity = ; absorption = .				

Figure 1-14: Coarse and Fine Aggregates Specific Gravity Data Sheet (ASTM Designations: C 127 and C 128)

- **Common testing errors**
- Improper identification of SSD, i.e. over or under-drying.
- Air entrapped in suspended sample or sample immersion container.
- Suspension apparatus in contact with another object, resulting in false readings.
- Loss of material during transfer to the drying pans.
- Weighing errors (i.e. Improper Tare weights or loss of material)
- Improper Pycnometer calibration
- Air entrapped in sand leading to false weight measurement, due to volume of pycnometer occupied by air.
- Improper surface moisture test due to one or more of the following:
 - Improper drop of tamper (too high or too low during compaction into the cone)

- Insufficient timing of test. Testing should be completed more frequently as the sample approaches SSD condition. Experience with the test and knowledge of the material's characteristics will increase the accuracy of the test.
- Excess airflow near the test sample resulting in uneven drying of the sample.
- Loss of material during transfer to the drying pans resulting in an inaccurate calculation.

1.11 Experiment 4: Rodded Unit Weight of coarse aggregates (Bulk density) (Developed from: ASTM Designation: C 29)

● Introduction

Bulk Density – the mass of a unit volume of bulk aggregate material. This volume includes the volume of the aggregate particles and the voids between the particles. It can be calculated for the rodding as follows:

This method is for aggregate in an oven-dry condition.

$$M = (G - T)/V$$

Or,

$$M = (G - T) \times F$$

Where:

M = bulk density of aggregate, kg/m³ (lb/ft³);

G = mass (weight) of aggregate plus the measure, kg (lb);

T = mass of the measure, kg (lb);

V = volume of measure, m³ (ft³);

F = factor for measure, m⁻³ (ft⁻³)

When bulk density based on aggregate in a saturated-surface dry (SSD) condition is desired, use the following formula:

$$MSSD = M[1 + (A/100)]$$

Where:

MSSD = bulk density in SSD condition, kg/m³(lb/ft³)

A = percent absorption,

● Purpose

Determination of the unit weight of coarse aggregates in a compacted condition. This test method is applicable to aggregates not exceeding 15 cm (6 in.) in nominal size. The unit weight so determined is necessary for the design of a concrete mixture by the absolute value method as explained beginning on pages 12 and 16, depending on the system of measurements.

● Equipment And Materials

- i) Balance accurate to 0.05 kg (0.1 lb) with a range to at least 25 kg (64 lb)
- ii) Straight steel tamping rod 16 mm (5/8 in.) diameter and about 60 cm (24 in.) in length with one end rounded in a hemispherical tip

- iii) Watertight metal bucket having approximately equal height to diameter ratio, but the height should always be between 80 to 150% of the diameter
- iv) Quantity of oven-dry aggregate sample should be at least 125% of the quantity required to fill the metal pail

- **Test Procedure**

- i) Calibrate the metal bucket to determine its volume by determining the net weight of water required to fill it and dividing it by the density of water. For this test procedure, it is sufficiently accurate to accept the density of water at room temperature to be 998 kg/m³ (62.3 lb/ft³).
- ii) Rodding the aggregates: Fill the bucket one third full and rod the aggregate layer with 25 strokes of the tamping rod, evenly distributed over the surface. Add another layer of aggregates so that the bucket is approximately two thirds full and repeat the rodding procedure. The third layer of aggregates should fill the pail to overflowing. Again repeat the tamping procedure and strike off the excess with the tamping rod. Manually try to balance the depressions below the top of the bucket with slight projections above the top. When tamping the first lift, do not permit the rod to penetrate to the bottom of the bucket. However, the subsequent lifts should penetrate to the top of the previous lift.
- iii) The rodded unit weight is computed in kg/m³ (lb/ft³) from the net weight of the rodded aggregates in the bucket divided by its volume.
- iv) Report the results for bulk density to the nearest 10 kg/m³ (1 lb/ft³).

- **Explanation Of Computations and Data sheets**

- Computations: Calculate the rodded unit weight as follows:
MSSD = Rodded unit weight of the saturated surface dry aggregate, kg/m³(lb/ft³)
G = Combined mass of the oven-dry aggregate and the bucket, kg(lb)
T = Mass of the bucket alone, kg(lbf)
V = Volume of the bucket, m³(ft³)
A = Percent absorption
$$MSSD = [(G - T) * (1 + A/100)]/V$$
- Calculate the rodded unit weight to the nearest 10 kg/m³ (1 lb/ft³). Conduct three tests. Average any two that do not differ by more than 40 kg/m³ (2.5 lb/ft³).
- Data sheet: There are no special data sheets for this test. Follow the instructions included
- Generally, at the concrete lab in Birzeit University, this test is carried out for oven-dry condition. Therefore, the same procedure mentioned here for the saturated surface dry conditions should be followed. However, the previously mentioned equation for the Oven dry condition should be employed.

Chapter Two: Fresh Concrete Tests

2.1.General Introduction

Concrete may be considered as composed of four basic separate ingredients: cement, coarse aggregates, fine aggregates, and water. Another way of looking at concrete is that of a graded mixture of fine and coarse aggregates held together by wetted cement. Still another way of viewing concrete is that the coarse aggregates are held together by a mortar which is composed of cement, fine aggregates, and water. The requirements of concrete are complex, but the ultimate aim is to produce the most economical combinations of concrete materials that will satisfy the performance requirements and specifications. A properly designed concrete mixture should possess the following physical properties:

- When still in the plastic state, it must be adequately workable.
- Must fulfill the required strength parameters.
- Durability to be able to withstand imposed forces and elements such as traffic abrasion for a concrete pavement.
- Other properties which may vary in importance with the location of the concrete in a structure are permeability and appearance.

2.1.1. Various Lab Test on Concrete

There are many tests which are conducted to check the quality of concrete. These tests are basically divided into two categories.

□ Various Lab Test on Fresh Concrete

Under these, the following tests will be carried out in laboratory:

- i. Slump test
- ii. Compacting factor
- iii. Vee-Bee test

□ Various Lab Test on Hardened Concrete

There are two kinds of tests which are done on hardened concrete. These are non-destructive test and destructive tests. Both of them will be done during this course. In non-destructive test, the sample is not destroyed and this test is very useful in determining the strength of existing buildings or structures where as in destructive test a sample is made and then destroyed to find out the strength of concrete. Compression and core tests are the example of destructive test. The nondestructive tests that will be carried out are the Rebound Hammer and Ultrasonic Pulse velocity tests.

2.1.2. Test to determine the workability of fresh concrete (Developed from ASTM C-125, 143, and ACI Standard 211.3.)

□ Definition of workability

Workability of concrete is defined in ASTM C-125 as the property determining the effort required to manipulate a freshly mixed quantity of concrete with minimum loss of homogeneity. The term manipulate includes the early-age operations of placing, compacting, and finishing. The effort required to place a concrete mixture is determined largely by the overall work needed to initiate and maintain flow, which depends on the rheological property of the lubricant (the cement paste) and the internal friction between the aggregate particles on the one hand, and the external friction between the concrete and the surface of the formwork on the other.

Consistency, measured by the slump-cone test or Vebe apparatus (described below), is used as a simple index for mobility or flowability of fresh concrete. The effort required to compact concrete is governed by the flow characteristics and the ease with which void reduction can be achieved without destroying the stability under pressure. Stability is an index for both the water-holding capacity (the opposite of bleeding) and the coarse-aggregate-holding capacity (the opposite of segregation) of a plastic concrete mixture. A qualitative measure of these two characteristics is generally covered by the term cohesiveness. It should be apparent by now that workability is a composite property, with at least two main components:

- Consistency (describes the ease of flow) and
- Cohesiveness (describes the stability or lack of bleeding and segregation characteristics.)

Like durability, workability is not a fundamental property of concrete; to be meaningful it must be related to the type of construction and the method of placement, compaction, and finishing. A concrete that can readily be placed in a massive foundation without segregation, may be entirely unworkable to form a thin structural member. Concrete judged to be workable when high-frequency vibrators are available for consolidation, would be unworkable if hand tamping is used. The significance of workability in concrete technology is obvious. It is one of the key properties that affect constructability. Regardless of the sophistication of the mix design procedure used and other considerations, such as cost, a concrete mixture that cannot be placed easily or compacted fully is not likely to yield the expected strength and durability characteristics.

- **Measurements**

The composite nature of workability as a property, and its dependence on the type of construction and methods of placing, compacting, and finishing are the reasons why no single test method can be designed to measure workability. The most universally used test, which measures only the consistency of concrete, is called the slump test. For the same purpose, the second test in order of importance is the Vebe test, which is more meaningful for mixtures with low consistency. The third test is the compacting factor test, which attempts to evaluate the compactibility characteristic of a concrete mixture. The slump test is covered by ASTM C-143, and the other two tests by ACI Standard 211.3. Only brief descriptions of the equipment and procedures are given below.

- i. Slump test. The equipment for the slump test is indeed very simple. It consists of a tamping rod and a truncated cone, 300 mm height and 100 mm diameter at the top, and 200 mm diameter at the bottom. The cone is filled with concrete and then slowly lifted. The unsupported concrete cone slumps down by its own weight; the decrease in the height of the slumped cone is called the slump of concrete. The sequence of steps in the ASTM C 143 test procedure are shown in Fig. 2-1. The slump test is not suitable for measuring the consistency of a very wet or very dry concrete mixture. Also, it is not a good measure of workability although it is a fairly good measure of the consistency or flow characteristic of plastic concrete. This test is not a satisfactory measure of the rheological behavior of concrete, the main reason why it is popular is that it provides a simple and convenient method for controlling the batch-to-batch uniformity of ready-mixed concrete. For example, a more than normal variation in slump may mean an unexpected change in the mixture proportions, aggregate grading, or moisture in aggregate. The test result enables the ready-mixed concrete plant operator to investigate and remedy the problem.

- **Purpose**

The purpose is to determine the consistency of a freshly mixed concrete by measuring the slump.

- **Materials and equipment**

- Frustum of a cone made of noncorrosive sheet metal not less than 1.14 mm (0.045 in.) thick, 30.5 cm (12 in.) in height, with a 20.8 cm (8 in.) base, having a diameter at the top of 10.2 cm (4 in.), with foot pieces and handles (Figure 2-2). There should also be a metal base plate with clamps that engages the foot pieces while the concrete is being poured into the slump cone and tamped with the tamping rod.

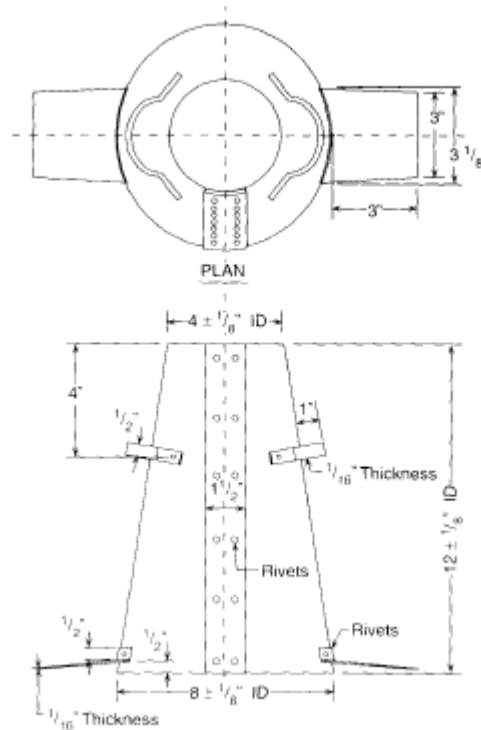

Figure 2-2: Mold for slump cone

- Round steel tamping rod 16 mm (5/8 in.) diameter, having the tamping end rounded to a hemispherical tip, approximately 60 cm (24 in.) long.
- Suitable, graduated metal scale approximately 50 cm (2 ft.) in length.
- **Test procedure**
 - Dampen the slump cone and the metal base plate, then engage the slump cone with the base plate clamps. The base plate should rest on a level surface.
 - Fill the slump cone in three lifts, tamping each lift 25 times with the tamping rod, starting from the center and working toward the perimeter. The bottom lift should be rodded the full depth down to the base plate. For the two other lifts, the strokes of the tamping rod should penetrate into the underlying concrete layer. The top lift should remain heaped above the top of the slump cone after completing the rodding. Each of the three lifts should contain approximately an equal volume of concrete. Therefore, the bottom layer should have a rodded depth of about 7 cm (2 1/2 in.) and the second lift to about 15 cm (6 in.).
 - Strike off the excess concrete with a screeding and rolling motion of the tamping rod.

- Remove the cone carefully with a slow vertical motion without any rotational or lateral motion. The entire procedure from the time the fresh concrete is ready for testing to this point should be no more than 5 min. The time from the filling of the slump cone to the determining of the slump should be within 2 1/2 min.
- Set the slump cone in an inverted position next to the concrete and measure the distance to the top of the original center of the specimen as shown in Figure 2-3.



Figure 2-3: Demonstration on use of a slump cone: (top) a low slump and (bottom) a high slump.

- **Explanation of Computations and data sheets**
 - i. Computations: Simply record the measured slump of the concrete to the nearest 6 mm (1/4 in.).
 - ii. Data Sheets: For this test, there is only one value to record and no special data sheets. Normally the percent of entrained air will be determined and recorded at the same time as the slump test is taken.

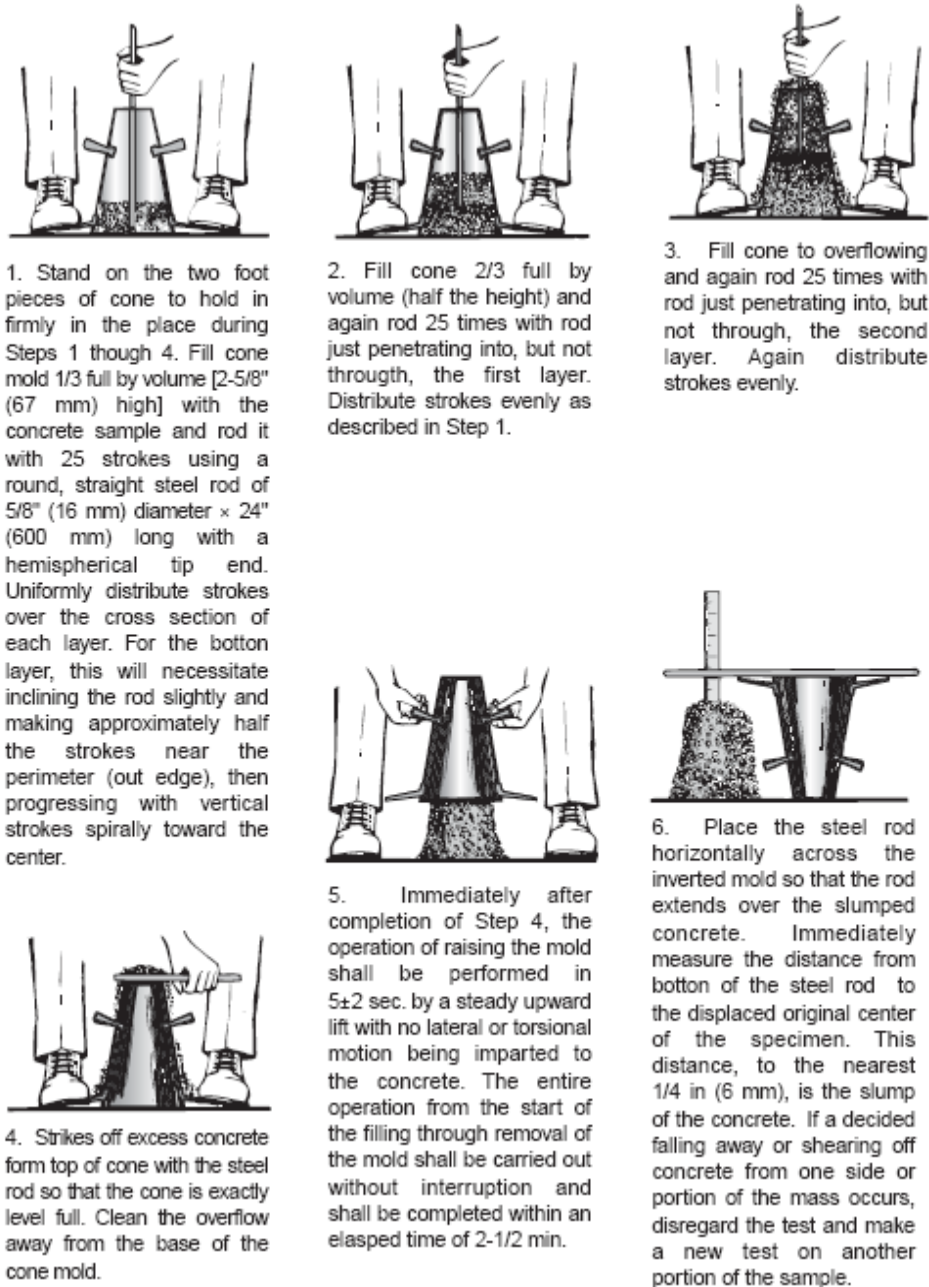

Figure 2-1: Sequence of steps in the slump test procedure.

- iii. There are three types of slump that are true, shear and collapse slumps. (see figure 2-4)

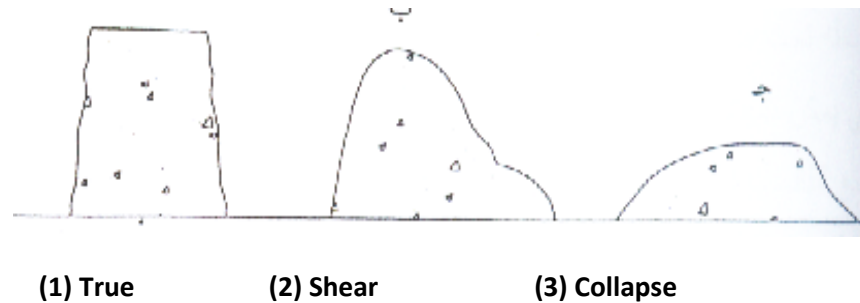

Figure 2-4: shapes of slumps

ii. Vee Bee Test

The equipment for the test, which was developed by Swedish engineer V. Bährner, is shown in Fig. 2-5a. It consists of a vibrating table, a cylindrical pan, a slump cone, and a glass or plastic disk attached to a freemoving rod that serves as a reference end point. The cone is placed in the pan, filled with concrete, and removed. The disk is brought into position on top of the concrete cone, and the vibrating table is set in motion. The time required to remold the concrete, from the conical to the cylindrical shape, is a measure of the consistency and is reported as Vebe seconds.

The Vebe time test is a more scientific test for workability than the slump test, in that it measures the work needed to compact the concrete. The freshly mixed concrete is packed into a similar cone to that used for the slump test. The cone stands within a special container on a platform, which is vibrated at a standard rate, after the cone has been lifted off the concrete. The time taken for the concrete to be compacted is measured. Vebe times range from 1 second for runny concrete to more than 12 seconds for stiff concrete. Unlike the slump test, the Vebe time test gives useful results for stiff concretes.

- **Procedure to determine workability of fresh concrete by Vee-Bee consistometer**
 1. A conventional slump test is performed, placing the slump cone inside the cylindrical part of the consistometer.
 2. The glass disc attached to the swivel arm is turned and placed on the top of the concrete in the pot.
 3. The electrical vibrator is switched on and a stop-watch is started, simultaneously.
 4. Vibration is continued till the conical shape of the concrete disappears and the concrete assumes a cylindrical shape.
 5. When the concrete fully assumes a cylindrical shape, the stop-watch is switched off immediately. The time is noted. The consistency of the concrete should be expressed in VB-degrees, which is equal to the time in seconds recorded above.

iii. Compacting Factor test

This test, developed in Great Britain, measures the degree of compaction achieved when a concrete mixture is subjected to a standard amount of work. The degree of compaction, called the compacting factor, is measured by the density ratio (i.e., the ratio of the density actually achieved in the test to the density of the same concrete when in a fully compacted condition). The apparatus consists essentially of two conical hoppers fitted with doors at the base and placed one above the other (Fig. 2-5b), and a 150 by 300 mm cylinder placed below the hoppers. The upper hopper, which is bigger than the lower, is filled with concrete and struck off without compacting. By opening the door at the bottom of the hopper, the concrete is allowed to fall by gravity into the lower hopper that overflows. This assures that a given amount of concrete is obtained in a standard state of compaction without the influence of human factor. The door of the lower hopper is released and the concrete falls into the cylinder. Excess material is struck off and the net weight of concrete in the known volume of the cylinder is determined, from which the density is easily calculated.

Compacting factor of fresh concrete is done to determine the workability of fresh concrete by compacting factor test as per IS: 1199 - 1959. The apparatus used is Compacting factor apparatus.

- **Procedure to determine workability of fresh concrete by compacting factor test**
 1. The sample of concrete is placed in the upper hopper up to the brim.
 2. The trap-door is opened so that the concrete falls into the lower hopper.
 3. The trap-door of the lower hopper is opened and the concrete is allowed to fall into the cylinder.
 4. The excess concrete remaining above the top level of the cylinder is then cut off with the help of plane blades.
 5. The concrete in the cylinder is weighed. This is known as weight of partially compacted concrete.
 6. The cylinder is filled with a fresh sample of concrete and vibrated to obtain full compaction. The concrete in the cylinder is weighed again. This weight is known as the weight of fully compacted concrete.

Compacting factor = (Weight of partially compacted concrete)/(Weight of fully compacted concrete)

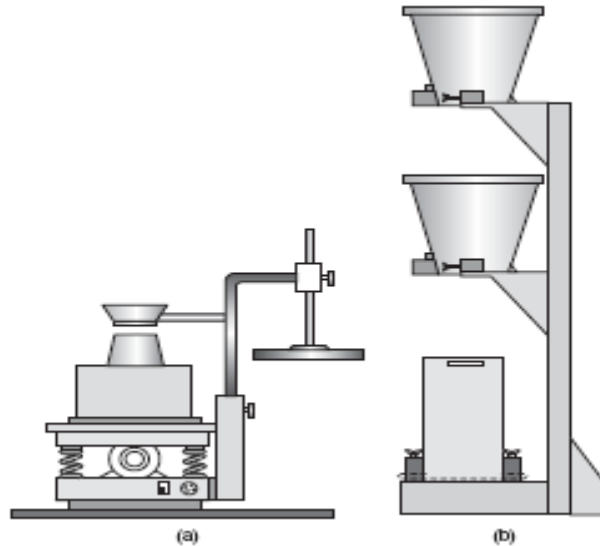

Figure 2-5: Equipment for measuring the consistency of concrete: (a) Vebe apparatus; (b) Compacting factor apparatus.

- **Factors affecting the workability and their control**

- Scanlon⁵ presents a comprehensive review of the test procedures and factors influencing the concrete workability. For obvious reasons, instead of workability it is more appropriate to consider how various factors affect consistency and cohesiveness because these two components of workability may be oppositely influenced by changing a particular variable. In general, through their influence on consistency and cohesiveness, the workability of concrete mixtures is affected by water content, cement content, aggregate grading and other physical characteristics, admixtures, and slump loss, as discussed below.
- Water content. ACI 211.1, Standard Practice for Proportioning Concrete Mixtures assumes that, for a given maximum size of coarse aggregate, the slump or the consistency of concrete is a direct function of the water content; that is, within limits it is independent of other factors such as aggregate grading and cement content. In predicting the influence of mixture proportions on the consistency, it should be noted that of the three factors, that is, water-cement ratio, aggregate-cement ratio, and water content, only two are independent. For example, when the aggregate-cement ratio is reduced but the water-cement ratio is kept constant, the water content increases and consequently the consistency. On the other hand, when the water content is kept constant but the aggregate-cement ratio is reduced, the water-cement ratio decreases and the consistency is not affected. Concrete mixtures with very high consistency tend to segregate and bleed, thereby adversely affecting the finishability; mixtures

with too low a consistency may be difficult to place and compact, and the coarse aggregate may segregate on placement.

- iii. Cement content. With conventional Portland-cement concrete at a given water content, a drastic reduction of the cement content would produce a harsh mixture with poor finishability. Concrete mixtures containing a very high cement content or high proportion of fine particles show excellent cohesiveness but tend to be sticky.
- iv. Aggregate characteristics. The particle size of coarse aggregate influences the water requirement for a given consistency. Also, very fine sands or angular sands require more water for a given consistency. Alternatively, they will produce harsh and unworkable mixtures at the water content that might have been adequate with a coarse or a well-rounded sand. As a rule of thumb, for similar consistency, concrete needs 2 to 3 percent more sand and 5 to 10 kg/m³ more mixing water by the absolute volume when crushed sand is used instead of a natural sand.
- v. Admixtures, when the water content of a concrete mixture is held constant, the addition of a water-reducing admixture increases the consistency. Entrained air increases the paste volume and improves the consistency of concrete for a given water content. It also increases cohesiveness by reducing bleeding and segregation. The improvement in consistency and cohesiveness by air entrainment is more pronounced in harsh and unworkable mixtures such as those used in mass concrete, which has a low cement content. Pozzolanic admixtures tend to reduce bleeding and improve the cohesiveness of concrete. Fly ash, when used as a partial replacement for fine aggregate, generally increases the consistency at a given water content.

- **Levels of Workability**

The British Department of the Environment (DOE) Method defines four levels of workability, which are given in the following table. Table 2 shows some typical values of reasonable slumps and Vebe times.

Description	Slump Range		Vebe Time Range
	mm	In.	Seconds
Very low	0 to 10	0 to	>12
Low	10 to 30	to 1	12 to 6
Normal	30 to 60	1 to 2	6 to 3
High	60 to 180	2 to 7	3 to 0

Table 2-1: levels of workability

Type of Construction	Suitable slump				Suitable Vebe time	
	mm		In.		Seconds	
	Min	Max	Min	Max	Max	Min
Uncongested precast concrete	0	25	0	1	-	12
Power vibrated pavements						
Mass concrete	0	50	0	2	-	4
Slabs	25	75	1	3	2	8
Footings						
Uncongested walls						
Columns	25	100	1	4	1	7
Beams						
Normally reinforced walls						
Congested narrow sections	100	175	4	7	0	2

Table 2-2: Some typical values of reasonable slumps and Vebe times

2.2. Making and Curing Concrete test specimens in the laboratory (Developed from ASTM Designation: C 192)

2.2.1. Purpose

Procedures for making and curing concrete test specimens under conditions of laboratory control.

2.2.2. Introduction

The term curing of concrete involves a combination of conditions that promote the cement hydration, namely time, temperature, and humidity conditions immediately after the placement of a concrete mixture into formwork. At a given water-cement ratio, the porosity of a hydrated cement paste is determined by the degree of cement hydration. Under normal temperature conditions, some of the constituent compounds of Portland cement begin to hydrate as soon as water is added, but the hydration reactions slow down considerably when the products of hydration coat the anhydrous cement grains. This is because hydration can proceed satisfactorily only under conditions of saturation; it almost stops when the vapor pressure of water in capillaries falls below 80 percent of the saturation humidity. Time and humidity are therefore important factors in the hydration process controlled by water diffusion. Also, like all chemical reactions, temperature has an accelerating effect on the hydration reactions.

- Time. It should be noted that the time-strength relations in concrete technology generally assume moist-curing conditions and normal temperatures. At a given water-cement ratio, the longer the moist curing period the higher the strength (Fig. 2-6), assuming that the hydration of anhydrous cement particles is still going on. In thin concrete elements, if water is lost by evaporation from the capillaries, air-curing conditions prevail, and strength will not increase with time (Fig. 2-7). The evaluation of compressive strength with time is of great concern to structural engineers. ACI Committee 209 recommends the following relationship for moist-cured concrete made with normal Portland cement (ASTM Type I):

$$f_{cm}(t) = f_{c28} \left(\frac{t}{4 + 0.85t} \right)$$

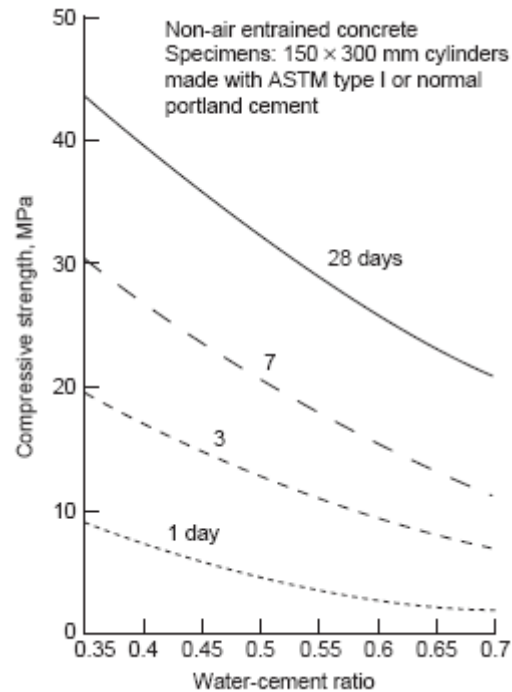

Figure 2-6: Influence of the water cement ratio and moist curing age on concrete strength.

For concrete specimens cured at 20°C, the CEB-FIP Models Code (1990) suggests the following relationship:

$$f_{cm}(t) = \exp\left\{s\left[1 - \sqrt{\frac{28}{t/t_1}}\right]\right\} f_{cm}$$

Where:

$f_{cm}(t)$ = mean compressive strength at age t days

f_{cm} = mean 28-day compressive strength

s = coefficient depending on the cement type, such as $s = 0.20$ for high early strength cements, $s = 0.25$ for normal hardening cements; $s = 0.38$ for slow hardening cements

$t_1 = 1$ day

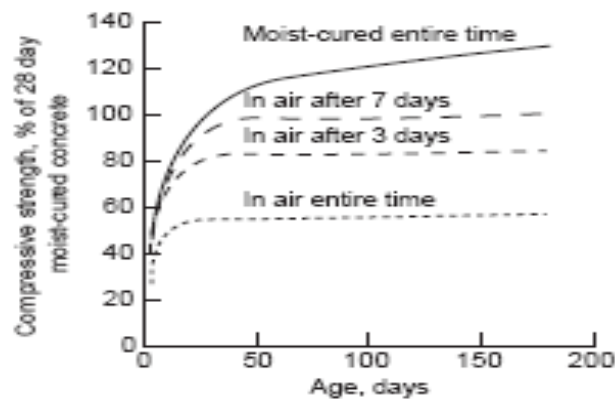

Notes: The curing age would not have any beneficial effect on the concrete strength unless curing is carried out in the presence of moisture.

Figure 2-7: Influence of curing conditions on strength.

- Humidity.** The influence of the curing humidity on concrete strength is obvious from the data in Fig. 2-7, which show that after 180 days at a given water-cement ratio, the strength of the continuously moist-cured concrete was three times greater than the strength of the continuously air-cured concrete. Furthermore, probably as a result of microcracking in the interfacial transition zone caused by drying shrinkage, a slight retrogression of strength occurs in thin members of moist-cured concrete when they are subjected to air-drying. The rate of water loss from concrete soon after the placement depends not only on the surface/volume ratio of the concrete element but also on temperature, relative humidity, and velocity of the surrounding air. A minimum period of 7 days of moist-curing is generally recommended with concrete containing normal portland cement; obviously, with concrete mixtures containing either a blended portland cement or a mineral admixture, longer curing period is desirable to ensure strength contribution from the pozzolanic reaction. Moist curing is provided by spraying or ponding or by covering the concrete surface with wet sand, sawdust, or cotton mats. Since the amount of mixing water used in a concrete mixture is usually more than needed for Portland cement hydration (estimated to be about 30 percent by weight of cement), proper application of an impermeable membrane soon after the concrete placement provides an acceptable way to maintain the strength development at a satisfactory rate. However, moist-curing should be the preferred method when control of cracking due to autogenous shrinkage or thermal shrinkage is important.
- Temperature.** With moist-cured concrete the influence of temperature on strength depends on the time-temperature history of casting and curing. This can be illustrated with the help of three cases: concrete cast and cured at the same temperature, concrete cast at different temperatures but cured at a normal

temperature, and concrete cast at a normal temperature but cured at different temperatures. In the temperature range 5 to 46°C, when concrete is cast and cured at a specific constant temperature, it is generally observed that up to 28 days, the higher the temperature the more rapid the cement hydration and the strength gain. From the data in Fig. 2-8, it is evident that the 28-day strength of specimens cast and cured at 5°C was about 80 percent of those cast and cured at 21 to 46°C. At later ages, when the differences in the degree of cement hydration disappear, so do the differences in the concrete strength. On the other hand, as explained below, it has been observed that the higher the casting and curing temperature, the lower will be the ultimate strength.

The data in Fig. 2-8b represent a different time-temperature history of casting and curing. The casting temperature (i.e., the temperature during the first 2 h after making concrete) was varied between 10 and 46°C; thereafter, all concrete mixtures were moist-cured at a constant temperature of 21°C. The data show that ultimate strengths (180-day) of the concrete cast at 5 or 13°C were higher than those cast at 21, 30, 38, or 46°C. From microscopic studies many researchers have concluded that, with low temperature casting, a relatively more uniform microstructure of the hydrated cement paste (especially the pore size distribution) accounts for the higher strength. With concrete mixtures cast at 21°C and subsequently cured at different temperatures from below freezing to 21°C, the effect of the curing temperature on strength is shown in Fig. 2-8c. In general, the lower the curing temperature, the lower would be the strength up to 28 days. At a curing temperature near freezing, the 28-day strength was about one-half of the strength of the concrete cured at 21°C; hardly any strength developed at the below-freezing curing temperature. Since the hydration reactions of Portland cement compounds are slow, it appears that adequate temperature levels must be maintained for a sufficient time to provide the needed activation energy for the reactions to begin. This enables the strength development process that is associated with progressive filling of voids with hydration products, to proceed unhindered. The influence of time-temperature history on concrete strength has several important applications in the concrete construction practice. Since the curing temperature is far more important to the strength than the placement temperature, ordinary concrete mixtures that are placed in cold weather must be maintained above a certain minimum temperature for a sufficient length of time. Concrete cured in summer or in a tropical climate can be expected to have a higher early strength but a lower ultimate strength than the same concrete cured in winter or in a colder climate. In the precast concrete products industry, steam curing is used to accelerate strength development to achieve quicker mold release. In massive elements, when no measures for temperature control are taken, for a long time the temperature of concrete will remain at a much higher level than the

environmental temperature. Therefore, compared to the strength of the specimens cured at normal laboratory temperature, the in situ concrete strength will be higher at early ages and lower at later ages.

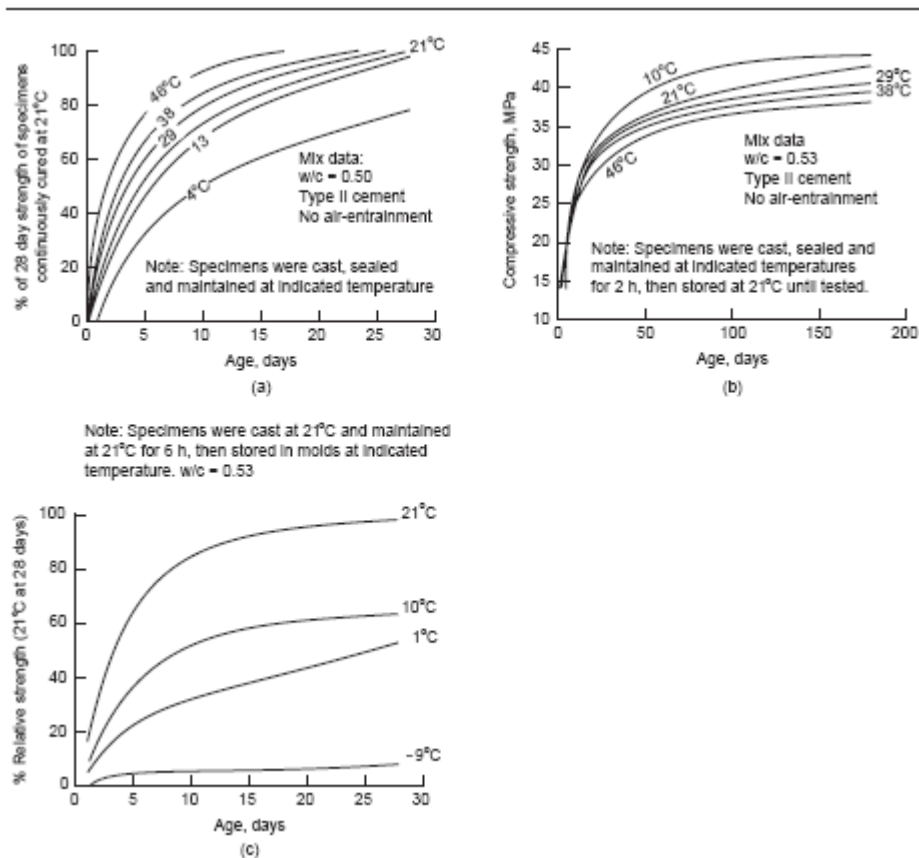

Concrete casting and curing temperatures control the degree of cement hydration and thus have a profound influence on the rate of strength development as well as the ultimate strength.

Figure 2-8: Influence of casting and curing temperatures on concrete strength.

2.2.3. Equipments and materials

- Molds, forms, and tamping rods as specified for the particular specimens being prepared
- Vibrating table
- Appropriate apparatus for determining the slump, percent of air entrainment, and yield in accordance with the appropriate ASTM Designations
- Scales
- Concrete mixer
- Necessary hand tools such as shovels, pails, trowels, scoops, pans, curing materials with which to cover the freshly made specimens, and rubber gloves
- Cement, aggregates, water, and additives (if required)

2.2.4. Test procedure

- The moisture content of the aggregates must be determined prior to any mixing operations in order to be able to calculate how much water needs to be added. An adjustment also must be made to the weight of aggregates required, based on the amount of absorbed and free water present.
- Just prior to the start of mixing, the mixer must be “battered” with a small quantity of a mortar mix, consisting of fine aggregates, cement, and water in the approximate proportions to closely simulate the test batch. The quantity should be just sufficient to coat the inside of the drum of the mixer. The purpose is to prevent the loss of mortar from the concrete to coat the drum.
- When additives are called for in the concrete mix, disperse them in the initial three quarters of the estimated mixing water. The additives should be thoroughly dispersed in the mixing water. If more than one additive is called for, disperse each additive in separate mixing water containers.
- Before starting the rotation of the drum, charge the mixer with the coarse aggregates and about one quarter of the mixing water. Start the mixer and add the fine aggregate, cement, and one half of the estimated required mixing water in that order. Mix for 3 min. after all of the ingredients have been added, followed by a 3 min. rest period. During this time take a slump test to determine how much of the remaining mixing water should be added in order to obtain the required slump. Except as necessary for conducting the slump test, keep the open end of the mixer covered during the rest period to prevent loss of moisture. This is followed by a final 2 min. of mixing.
- At the completion of mixing, deposit the concrete in a suitable, clean damp pan. If necessary remix the fresh concrete by shovel or trowel until it appears uniform. Then take whatever tests are called for such as the final slump test, compacting factor and Vee bee test as described above. Based on these tests a further adjustment may need to be made to the mix design. The trial mixtures should have a slump of ± 20 mm (± 0.75 in.), of the maximum permitted. Reduce the mixing water by 5 kg (10 lb) for each 25 mm (1 in.) in required slump reduction and, of course, the converse is likewise true to increase the slump. Once the mix has been redesigned, taking the above factors into account and the yield, a new trial batch needs to be made and tested for conformity with specifications.
- Once a satisfactory mix has been produced, prepare the specimens for the testing program. The quantity of each mix in the laboratory should be based upon the volume of concrete required to prepare the specimens or the maximum mixing capacity of the mixing drum, as specified by the lab technician, whichever is smaller.
- All specimens should be removed from their molds or forms and placed in the curing facility not less than 16 hours nor more than 32 hours after casting.
- The specimens are to remain in the curing environment until just before they are ready for testing. All specimens should be tested while their surfaces are still thoroughly moist. Curing for all specimens may be carried out by continuous immersion in saturated lime water. However, for flexure, specimens must be in a saturated lime solution for at least 20 hours prior to testing at a temperature of $23 \pm 1.7^\circ\text{C}$ ($73.4 \pm 3^\circ\text{F}$).

2.2.5. Explanation of computations and data sheets

- Computations: The only computations necessary involve the mix design and modifications as indicated by the results of the trial batches, as described herein.
- Data Sheets: Those used in this procedure are according to the specimens prepared, such as for compression, flexure, tension, bond, Young's modulus, Poisson's ratio, etc., each of which has its own specially prepared data sheet. These tables are initially to be filled out when the specimens are prepared and completed at the time of testing. The mix design is based on the initial computations and then as modified by the trial batches. The tables were designed both for the concrete mixture used as well as the test results of the specimens.

2.2.6. Notes

- This procedure should be followed for the Job mix design experiments with some adjustment.
- At this stage, the instructor will give the data for such mix design, and the students will not do any calculation.
- After carrying out some experiments such as slump, vee bee and compacting factors, the students have to fill 5 small cubes (10*10*10) and two small prisms with two lifts of freshly mixed concrete, tamping each lift 25 times with the tamping rod. As well as they have to fill two large cubes (15*15) and two cylinders with three lifts of freshly mixed concrete, tamping each lift 25 times with the tamping rod. Also tap each lift lightly with a mallet 10 to 15 times.
- For all of the samples the student have to Strike off the excess concrete with the tamping rod and finish to a smooth surface with a steel trowel.
- The students have to do that for the other three trials of freshly mixed concrete.
- Compacting for each specimen could be carried out manually or using a vibrating table which is available at Birzeit Concrete lab.
- The table below shows the data for the mixtures which are performed at Birzeit Concrete lab

W/C Ratio	Water liter	Cement Kg	Sand Kg	Aggregate Kg
	0.5	1	2	4
0.6	6.336	10.560	20.8	41.6
0.7	7.368	10.526	20.8	41.4
0.8	8.310	10.388	20.8	41.4
0.9	9.230	10.256	20.5	40.958

- The least curing time is 7 days. However, most of the specimens are cured for 28 days.
- The curing conditions are according to the ASTM specifications mentioned in the test procedure above.
- At this stage, the students just record the slump, vee bee and the compacting factors. Furthermore, in their reports they have to comment about the recorded values.

2.3. Compressive Strength of Cylindrical and Cubical Concrete Specimens (Developed from ASTM Designation: C 39)

2.3.1. Purpose

The purpose is to determine the compressive strength of both cylindrical and cubical specimens. Knowing that, the same procedure can be carried out for drilled cylindrical. The method is limited to concrete having a density of at least 800 kg/m^3 (50 lb/ft^3). The 28-day compressive strength (f_c') of molded cylinders is normally used in design.

2.3.2. Introduction

The strength of concrete is the property most valued by designers and quality control engineers. In solids, there exists a fundamental inverse relationship between porosity (volume fraction of voids) and strength. Consequently, in multiphase materials such as concrete, the porosity of each component of the microstructure can become strength-limiting. Natural aggregates are generally dense and strong; therefore, it is the porosity of the cement paste matrix as well as the interfacial transition zone between the matrix and coarse aggregate, which usually determines the strength characteristic of normal-weight concrete. Although the water-cement ratio is important in determining the porosity of both the matrix and the interfacial transition zone and hence the strength of concrete, factors such as compaction and curing conditions (degree of cement hydration), aggregate size and mineralogy, admixtures types, specimen geometry and moisture condition, type of stress, and rate of loading can also have an important effect on strength. In this chapter, the influence of various factors on concrete strength is examined in detail.

- Definition

The strength of a material is defined as the ability to resist stress without failure. Failure is sometimes identified with the appearance of cracks. However, microstructural investigations of ordinary concrete show that unlike most structural materials concrete contains many fine cracks even before it is subjected to external stresses. In concrete, therefore, strength is related to the stress required to cause failure and it is defined as the maximum stress the concrete sample can withstand. In tension testing, the fracture of the

test piece usually signifies failure. In compression, the test piece is considered to have failed even when no signs of external fracture are visible; however, the internal cracking has reached such an advanced state that the specimen is unable to carry a higher load.

- **Significance**

In concrete design and quality control, strength is the property generally specified. This is because, compared to most other properties, testing of strength is relatively easy. Furthermore, many properties of concrete, such as elastic modulus, watertightness or impermeability, and resistance to weathering agents including aggressive waters, are believed to be dependent on strength and may therefore be deduced from the strength data. The compressive strength of concrete is several times greater than other types of strength, therefore a majority of concrete elements are designed to take advantage of the higher compressive strength of the material. Although in practice most concrete is subjected simultaneously to a combination of compressive, shearing, and tensile stresses in two or more directions, the uniaxial compression tests are the easiest to perform in laboratory, and the 28-day compressive strength of concrete determined by a standard uniaxial compression test is accepted universally as a general index of the concrete strength.

- **Failure modes in concrete**

With a material such as concrete, which contains void spaces of various size and shape in the matrix and microcracks at the interfacial transition zone, the failure modes under stress are very complex and vary with the type of stress. A brief review of the failure modes, however, will be useful in understanding and control of the factors that influence concrete strength. Under uniaxial tension, relatively less energy is needed for the initiation and growth of cracks in the matrix. Rapid propagation and interlinkage of the crack system, consisting of preexisting cracks at the interfacial transition zone and newly formed cracks in the matrix, account for the brittle failure. In compression, the failure mode is less brittle because considerably more energy is needed to form and to extend cracks in the matrix. It is generally agreed that, in a uniaxial compression test on medium- or low-strength concrete, no cracks are initiated in the matrix up to about 50 percent of the failure stress; at this stage a stable system of cracks, called shear-bond cracks, already exists in the vicinity of coarse aggregate. At higher stress levels, cracks are initiated within the matrix; their number and size increases progressively with increasing stress levels. The cracks in the matrix and the interfacial transition zone (shear-bond cracks) eventually join up, and generally a failure surface develops at about 20° to 30° from the direction of the load, as shown in Fig. 2-9.



Figure 2-9: Typical failure mode of concrete in compression.

- **Compressive strength and factors affecting it**

The response of concrete to applied stress depends not only on the stress type but also on how a combination of various factors affects porosity of the different structural components of concrete. The factors include properties and proportions of materials that make up the concrete mixture, degree of compaction, and conditions of curing. From the standpoint of strength, the relationship between water-cement ratio and porosity is undoubtedly the most important factor because, independent of other factors, it affects the porosity of both the cement mortar matrix and the interfacial transition zone between the matrix and the coarse aggregate.

Direct determination of porosity of the individual structural components of concrete—the matrix and the interfacial transition zone—is impractical, and therefore precise models of predicting concrete strength cannot be developed. However, over a period of time many useful empirical relations have been found, which, for practical use, provide enough indirect information about the influence of numerous factors on compressive strength (compressive strength being widely used as an index of all other types of strength). Although the actual response of concrete to applied stress is a result of complex interactions between various factors, to facilitate a clear understanding of these factors they can be separately discussed under three categories: (1) characteristics and proportions of materials, (2) curing conditions, and (3) testing parameters. Figure 2-10 shows Interplay of factors influencing the concrete strength.

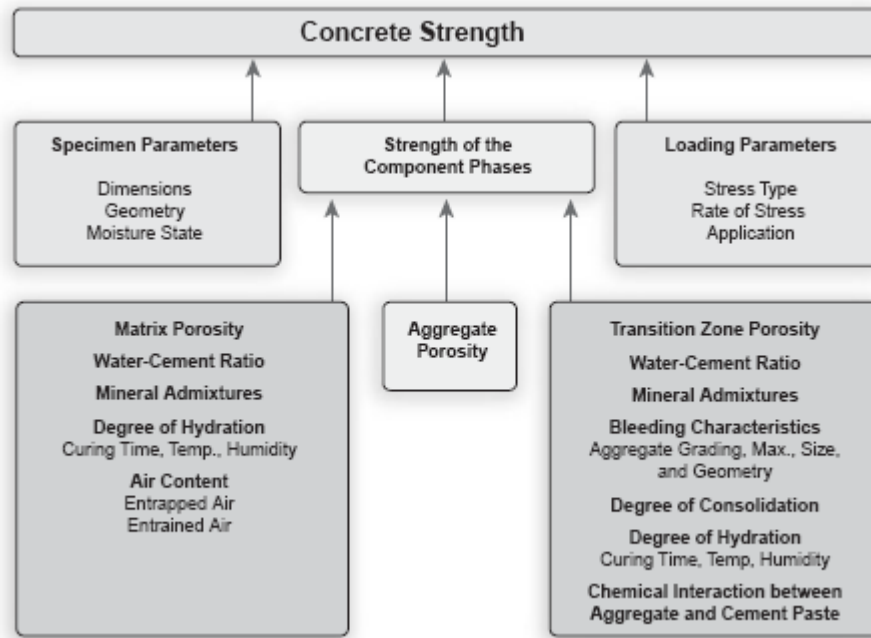

Figure 2-9: Interplay of factors influencing the concrete strength.

2.3.3. Equipment and Materials

- Reusable steel or wax-coated cardboard disposable cylindrical molds, 15 cm (6 in.) in diameter by 30 cm (12 in.) in height or 10 cm (4 in.) in diameter by 20 cm (8 in.) in height
- Reusable steel or wax-coated cardboard disposable cubical molds, both small (10*10*10) and large (15*15*15)
- Moist storage facility for curing the fresh concrete specimens
- Straight steel tamping rod that is 16 mm (5/8 in.) in diameter and about 60 cm (24 in.) in length with one end rounded in a hemispherical tip
- Rubber mallet weighing about 0.6 kg (1.3 lb)
- A set of special steel caps of appropriate diameter with a neoprene pad contact with the concrete for capping the specimen
- Testing machine capable of applying load continuously at the rate of 0.14 to 0.34 MPa/s (20 to 50 psi/s) with a maximum load capacity of at least 150,000 kg (400,000 lb).
- Spacers

2.3.4. Test procedure

- Preparation of cylindrical and cubical specimens.
 - Prepare and cure the specimens.
 - Perform compacting factor, slump, and vee bee tests on the fresh concrete prior to casting the specimens.

- Fill the cylinders and large cubes with three lifts of freshly mixed concrete, tamping each lift 25 times with the tamping rod. Also tap each lift lightly with a mallet 10 to 15 times.
- Strike off the excess concrete with the tamping rod and finish to a smooth surface with a steel trowel.
- Fill the small cubes with 2 lifts of freshly mixed concrete, tamping each lift 25 times with the tamping rod.
- Strike off the excess concrete with the tamping rod and finish to a smooth surface with a steel trowel.
- It is recommended that specimens be prepared and tested in groups of three.
- Curing of the concrete specimens.
 - Allow the specimens to set for about 24 hours at normal room temperature, with the top surface covered to prevent loss of moisture.
 - Strip the mold from the specimens and place in the curing facility until ready for testing.
- Compression Testing Procedure for the cylindrical specimens .
 - Remove the specimen from the curing facility just prior to testing. Specimens shall be tested while still in a moist condition.
 - Measure the diameter of the specimen, determined at right angles to each other about mid-height of the specimen. Average the two values to the nearest 0.25 mm (0.01 in.).
 - Center the capped specimens in the testing machine and load at the prescribed rate of 0.14 to 0.34 MPa/s (20 to 50 psi/s).
 - Load to failure.
 - Record the ultimate load, the angle of fracture, and any other pertinent aspects of failure such as voids.
- Compression Testing Procedure for the small and large cubical specimens .
 - Remove the specimen from the curing facility just prior to testing. Specimens shall be tested while still in a moist condition.
 - Measure the dimensions for all cubes.
 - Record the weight of all of the specimens as SSD and soaked in water.
 - Center the specimens in the testing machine and load at the prescribed rate of 0.14 to 0.34 MPa/s (20 to 50 psi/s).
 - Load to failure
 - Record the ultimate load, the angle of fracture, and any other pertinent aspects of failure such as voids.

2.3.5. Explanation for computation and data sheets

- **Cylindrical specimens**
 - **Computations:** Determine the compressive strength of each specimen by dividing the maximum load to failure by the average cross-sectional area as explained in No. 3b above. The compressive strength of the mix should be based upon the average of the test results of the three specimens. The usual practice in industry is to prepare and test only two specimens. Based on the researcher's experience, three specimens are recommended in a learning laboratory. If any one of the three specimens is badly honeycombed or obviously deficient in some other aspect, it may be discarded and not included in the test results for that mix. The results of any one specimen whose value differs from the average of the other two by more than 10% should be carefully examined. They may indicate testing, handling, or mixing problems. The value of any set should be carried to the nearest 100 kPa (10 psi) for the average of all specimen results used. The standard recognized cylinder size is 15 cm (6 in.) diameter by 30 cm (12 in.) in height. However, an accepted alternative size is 10 cm (4 in.) diameter by 20 cm (8 in.) in height. The smaller cylinders are becoming increasingly popular because they require less material, are easier to handle, and less storage space is needed. However, the latter tend to break at slightly higher strengths. Therefore, the values determined should be multiplied by 0.95 in order to better correlate with the standard of 15-cm (6 in.) diameter specimens.
 - **Data Sheet:** The following page includes the data sheet for this test.

Data Sheet (ASTM C 39)

Date specimens were cast:						
Description of test specimens:						
Concrete mix design: C.A. ; F.A. ; P.C. ; Water						
Additives ; Maximum size C.A. ; F.M.						
Spec. No.	Days Cured	Area cm ² /in. ²	Load kg/lb	Fract. Angle	Stress MPa/psi	% f'_c

* f'_c based upon average 28-day strength for the concrete mix.

Figure 2-10: Data sheet

- **Cubical specimens**
 - **Computations:** Determine the compressive strength of each specimen by dividing the maximum load to failure by the average cross-sectional area. The compressive strength of the mix should be based upon the average of the test results of the three specimens. The usual practice in industry is to prepare and test only two specimens. Based on the researcher's experience, three specimens are recommended in a learning laboratory. If any one of the three specimens is badly honeycombed or obviously deficient in some other aspect, it may be discarded and not included in the test results for that mix. The results of any one specimen whose value differs from the average of the other two by more than 10% should be carefully examined. They may indicate testing, handling, or mixing problems. The value of any set should be carried to the nearest 100 kPa (10 psi) for the average of all specimen results used. The standard recognized cube size is $15 \times 15 \times 15 \text{ cm}^3$. However, an accepted alternative size is $10 \times 10 \times 10 \text{ cm}^3$. The smaller cubes are becoming increasingly popular because they require less material, are easier to handle, and less storage space is needed. However, the latter tend to break at slightly higher strengths. Therefore, the values determined should be multiplied by 0.975 in order to better correlate with the standard of 15-cm specimens.
 - **Data Sheet:** The following page includes the data sheet for this test.

Date specimens were cast:								
Description of test specimens:								
Concrete mix design: C.A. ; F.A. ; P.C. ; Water								
Additives; Maximum size C.A. ; F.M.								
<i>Spec. No.</i>	<i>Days Cured</i>	<i>Weight of Spec. (kg)</i> <i>SSD</i>	<i>Weight of Spec. soaked</i> <i>(kg)</i>	<i>Area</i> <i>² cm</i>	<i>load</i> <i>Kg</i>	<i>Fract. Angle</i>	<i>Stress MPa</i>	<i>%f_c'</i>

2.3.6. Reports

- Students have to find the density of both small and large cubes
- Students have to draw five graphs which are(Yvs.X):
 - The compressive strength or stress for all specimens vs. w/c
 - The compressive strength or stress for small cubes vs. large ones
 - The compressive strengths or stress for all specimens vs. time of curing (just for small cubes)
 - The compressive strength or stress vs. (for both large and small cubes)
 - The compressive strength or stress of large cubes vs. cylindrical specimens
- For that graphs they have to find the factor to be multiplied in order to correlate the small cubes with the standard ones. As well as they should have to find the factors to be multiplied in order to correlate the large cube with the standard cylindrical specimen.
- These correlations factors should be compared to the standard mentioned above.

2.4. Testing methods for tensile strength

Direct tension tests of concrete are seldom carried out, mainly because the specimen holding devices introduce secondary stresses that cannot be ignored. The most commonly used tests for estimating the tensile strength of concrete are the splitting tension test and the third-point flexural loading test (Fig. 2-11). In the splitting tension test a 15- by 30- cm concrete cylinder is subjected to compression loads along two axial lines which are diametrically opposite. The load is applied continuously at a constant rate within the splitting tension stress range of 0.7 to 1.3 MPa until the specimen fails. The compressive stress produces a transverse tensile stress, which is uniform along the vertical diameter. The splitting tension strength is computed from the formula

$$T = \frac{2P}{\pi Ld}$$

Where T = tensile strength

P = failure load

L= length

d = diameter of the specimen

Compared to direct tension, the splitting tension test is known to overestimate the tensile strength of concrete by 10 to 15 percent

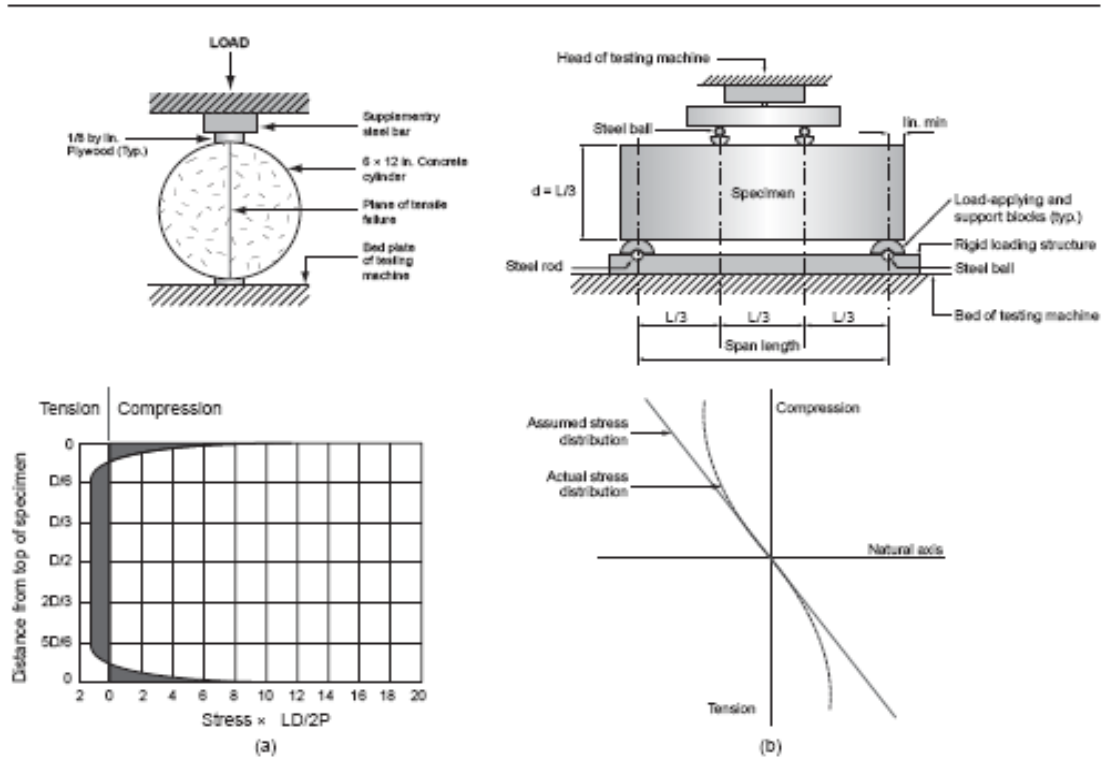

Figure 2-11 : (a) Splitting tension test: top, diagrammatic arrangement of the test; bottom, stress distribution across the loaded diameter of a cylinder compressed between two plates. (b) Flexural test by third-point loading: top, diagrammatic arrangement of the test; bottom, stress distribution across the depth of a concrete beam under flexure.

In the third-point flexural loading test, a 150- by 150- by 500 mm concrete beam is loaded at a rate of 0.8 to 1.2 MPa/min (125 to 175 psi/min.). Flexural strength is expressed in terms of the modulus of rupture, which is the maximum stress at rupture computed from the flexure formula

$$R = \frac{PL}{bd^2}$$

Where R = modulus of rupture

P = maximum indicated load

L = span length

b = width

d = depth of the specimen

The formula is valid only if the fracture in the tension surface is within the middle third of the span length. If the fracture is outside by not more than 5 percent of the span length, a modified formula is used:

$$R = \frac{3Pa}{bd^2}$$

Where a is equal to the average distance between the line of fracture and the nearest support measured on the tension surface of the beam. When the fracture is outside by more than 5 percent of the span length, the results of the test are rejected.

The flexure test is usually preferred for quality control of concrete for highway and airport pavements, where the concrete is loaded in bending rather than in axial tension. The CEB-FIP Model Code (1990) suggests the following relationship between direct tension strength (f_{ctm}) and flexural strength ($f_{ct,fl}$)

$$f_{ctm} = f_{ct,fl} \frac{2(h/h_o)^{0.7}}{1 + 2.0(h/h_o)^{0.7}}$$

Where h is the depth of the beam in mm, $h_o = 100$ mm, and strengths are expressed in MPa units.

2.4.1. Splitting tensile strength for cylindrical concrete specimens (Developed from ASTM Designation: C 496)

- **Purpose**

The purpose is to determine the splitting tensile strength of cylindrical concrete specimens. This test procedure is also referred to as the “Brazil Test” because it was developed by a Brazilian engineer.

- **Equipments and materials**

- Testing machine used before for cylindrical specimens ; if the diameter or the largest dimension of the upper bearing face is less than the length of the test cylinder, a supplementary bar is to be used with a length at least the length of the specimen, 5.1 cm (2 in.) wide and a thickness not less than the overhang distance between the bearing face of the testing machine and the specimen; the bar must be machined to within 0.025 mm
- Wood-bearing strips of 3.2-mm (1/8-in.) thick plywood strips, 25-mm (1-in.) wide, slightly longer than the length of the specimen; these wood strips are to be

- placed between the steel bars and the specimen to take account of deviations in the surface of the specimen, and are to be used only once and then discarded
- Suitable apparatus for aligning the specimen (Figure 2-12)

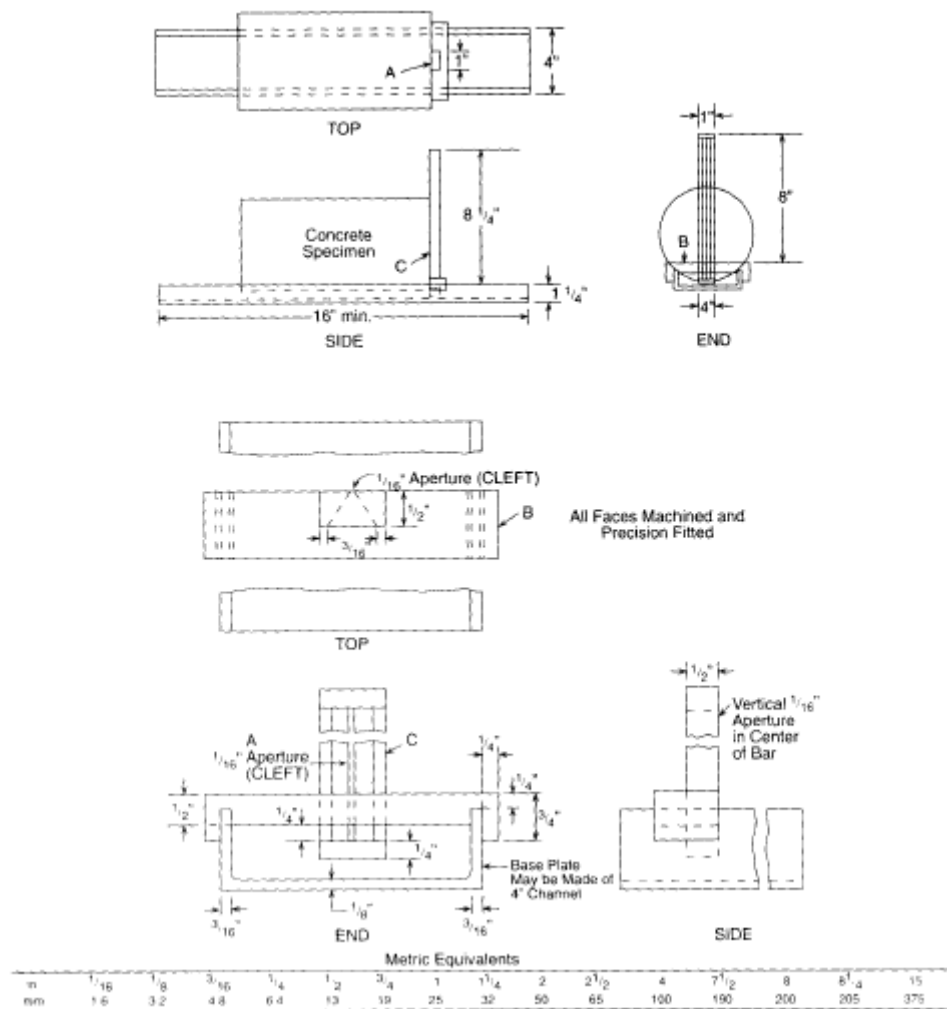

Figure 2-12: Details of an apparatus for aligning a specimen

• **Test Procedure**

- Draw diametral lines, cutting the axis of the cylinder at each end with the aid of a suitable alignment apparatus and then connect the diametral lines (figure 2-12b).

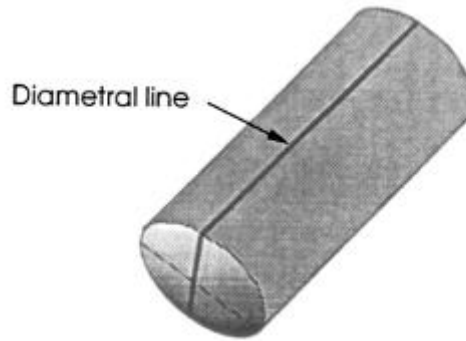

Figure 2-12b: Diametral line.

- Determine the diameter of the concrete specimen by averaging diameter measurements to the nearest 0.25 mm (0.01 in.), one at each end of the specimen and one at the center. Compute the length of the specimen by measuring the length at two locations, approximately 180° apart, to the nearest 2.5 mm (0.1 in.) and averaging them.
- Center one of the plywood strips on the lower platen of the compression machine and center one of the diametral lines of the specimen over the middle of the wood strip 2-13).

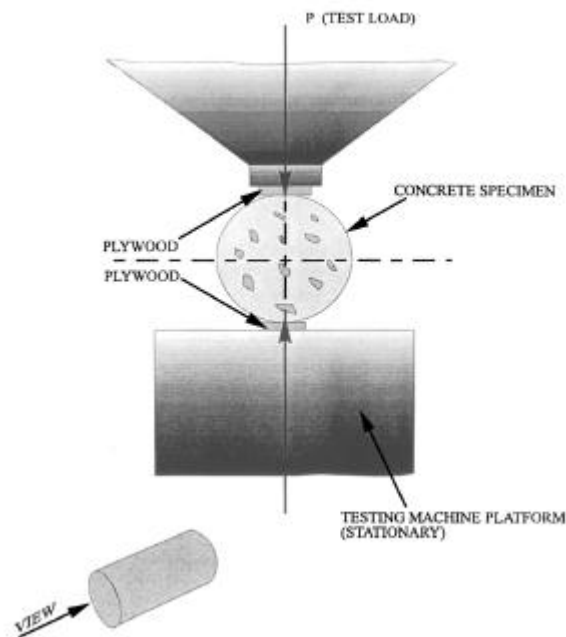

Figure 2-13: Diagram of a concrete cylinder in the testing machine showing the front view of the diameter of the specimen and setup in profile.

- Center another wood strip over the top diametral line of the specimen. Where necessary, carefully center the 5.1-cm (2-in.) wide steel bar over the wood strip.
 - Slowly lower the pressure head of the compression machine to the top of the steel bar or wood strip, as the case may be, until there is just enough pressure for the specimen to be held in place.
 - Apply a steady load on a 15.2 cm (6 in.) diameter \times 30.5 cm (12 in.) high concrete cylinder at an approximate rate of 4500 kg of mass per minute or 10,000 lb of force per minute. This translates to a stressing rate of 689 to 1380 kPa /min (100 to 200 psi/min). Record the load at failure, type of failure, and the appearance of the concrete at the plane of fracture.
- **Explanation of Computation and Data Sheet**
 - Computations: The tensile splitting strength of a concrete cylinder is computed from the Formula which is stated above.
 - Data Sheet: Note the data and computed results on the following illustrative data sheet. Under the Remarks column for specimen No. 1, it was noted that the failure took place because of coarse aggregate (C.A.) fracturing. In the other two specimens, the failure took place in the mortar; that is, between the coarse aggregate particles. An important consideration in the testing of concrete mixes is the percent a particular strength parameter compares to the 28-day $f'c$. The same consideration holds true for bond strength, tensile strength, etc. The standard by which all concrete strengths are compared is that of $f'c$ for the identical mix, cured under the identical conditions, and at the same age. Three parameters of measuring the tension strength of Portland cement concrete are included in this book. They are the modulus of rupture (M.R.), and the direct tension test. The first two are indirect evaluations of direct tensile strength, while the last is a direct evaluation.

Date of Test: 4/10/99 Date Specimens were Cast: 3/12/99 Description of Specimen: Moist cured for 28 days, the same mix design as used for compression specimens Length of Specimen, m or in. = 12.0 in. Diameter of Specimen in m or in. = 6.00 in. f'_c Concrete Mix Tested under ASTM Designation: C 39 = 5800 psi				
Specimen Number	Max. Load, Kg (mass) or lb/f	Splitting Strength, kPa or psi	Percent f'_c	Remarks
1	50,000 lb/f	442 psi	7.7	C.A. fractures
2	55,000 lb/f	486 psi	8.4	Mortar break
3	53,000 lb/f	469 psi	8.1	Mortar break
Average		466 psi	8.0	

Note: $T = (2 \times P)/(\pi \times l \times d)$

Figure 2-14: Illustrative example

Date of Test:

Date Specimens were Cast:

Description of Specimen:

Length of Specimen, m or in. =

Diameter of Specimen in m or in. =

f'_c of Concrete Mix Tested under ASTM Designation: C 39 =

Specimen Number	Max. Load, Kg (mass) or lb/f	Splitting Strength, kPa or psi	Percent f'_c	Remarks

Note: $T = (2 \times P)/(\pi \times l \times d)$

Figure 2-15: Data sheet

2.4.2. Flexural strength of concrete using simple beam with third-point loading (Developed from ASTM Designation: C 78)

- **Purpose**

The purpose is to determine the flexural strength of a concrete beam with loading at the third points.

- **Equipment and materials**

- Rigid steel forms 51 cm (20 in.) long by 15 cm (6 in.) in the other two dimensions
- Point loading apparatus capable of maintaining the specified span length and distance between load applying blocks and support blocks to within ± 0.13 cm (± 0.05 in.)
- Suitable loading machine capable of applying the loads at a uniform rate without interruption (See Figures 2-16 and 2-17 for details of the test beam and the loading apparatus.)

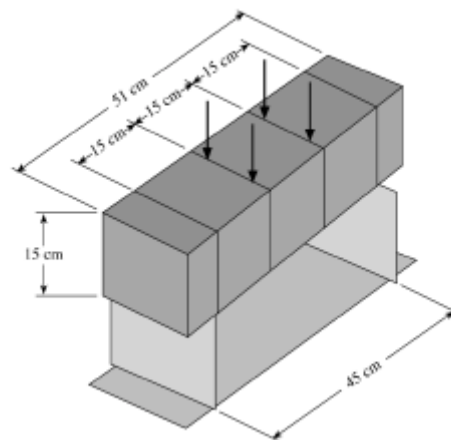

Figure 2-16: Three-dimensional view of test beam in loading apparatus.

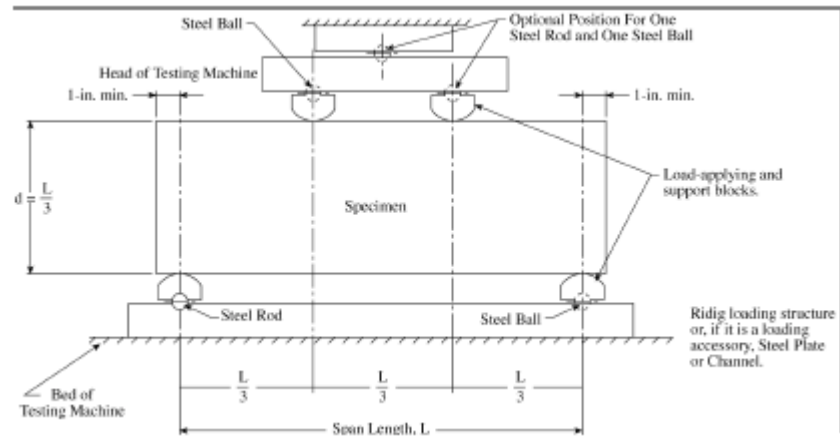

Figure 2-17: Diagrammatic view of third-point loading apparatus.

○ Test procedure

- Preparation: Make the specimens in accordance with the concrete batch procedure. Test the concrete for slump. Fill the beam forms with three lifts of concrete, tamping each lift 25 times with the 16 mm (5/8 in.) tamping rod or fill the form in one lift and consolidate the concrete with a mechanical vibrating table. Be careful not to over vibrate since that would cause segregation.
- Curing: Allow the specimens to remain in the steel forms with the top properly covered for about 24 hours at normal room temperature. Strip the forms and place the specimens in the curing facility until ready for testing.
- Testing: Remove the specimens from the curing facility and mark the beam where it will be in contact with the supports and at the opposite side where it will be in contact with the third-point loading. Remember that none of these contact points should be on the top or hand-finished surface of the specimen. In other words, the beam should be tested 90° to its casting position. This should assure proper contact at the load points. However, this should be checked. Use 6.4-mm (1/4-in.) thick leather shims, 3 cm (1 in.) long, for the full width of the specimen, wherever a gap in excess of 0.10 mm (0.004 in.) exists between the loading and support points and the specimen.
 - Begin the test as soon as possible while the specimen is still moist from the curing room.
 - Apply an initial load of 2300 kg (5000 lb) rapidly; continue loading at a rate of 450 kg (1000 lb) per minute until failure.

- Record the ultimate load, the exact location of fracture, and the type of failure.
 - If the failure occurs more than 5% of the length, 2.25 cm (0.9 in.) outside the middle third of the beam in the tension surface, discard the results of that specimen.
 - After the test, measure the cross-section at each end and at the center. Compute the average height and depth.
- **Notes**
 - This procedure is similar to the one carried out for the beam.
 - For the prisms, similar testing procedure is followed except that there is no flexural steel.
 - **Explanation for computations and data sheet**
 - Computations: The flexure strength (usually referred to as the modulus of rupture) is computed from the earlier stated equation. Compute the modulus of rupture to the nearest 0.05 MPa (5psi).
 - Data sheet Following is a data sheet with sample computations. The third column with the average $b \times d$ refers to the depth and height dimensions, respectively. In the illustrative example, the U.S. Standard of Measurements are used. It should be noted that the results for specimens 5 and 9 were disregarded. Specimen 5 broke at 3.9 in. from the closest support. Where the specimen breaks outside of the middle third of the beam, it must fracture within 5% of the middle third. Since in this test the distance between supports was 18 in., the minimum distance of the break from the nearest support must be 5.1 in. The distance as measured from the top face of the beam, in the position as tested, was only 3.9 in. In the case of beam specimen 9, the failure took place outside of the middle third. However, it was acceptable because the average distance of the fracture, again measured along the top surface, was within the 5% criterion. Nevertheless, the result of this specimen was rejected because its value of 623 psi differed by more than 16% from the values of the other two specimens which were quite close.

Date specimens were cast: 3/1/99; Comments:							
Description of test specimens: 6 in. x 6 in. x 21 in. beams; Distance between supports – 18 in.							
Specimen No.	Days Cured	Average $b \times d$ cm or in.	Load kg/lb	Location of Fracture	M.R. MPa/psi	% f'_c	Remarks
1	7	6.03 in. x 6.00 in.	7700 lb	Middle third	638 psi		$f'_c = 6450$ psi
2	7	5.98 in. x 6.02 in.	7600 lb	Middle third	631 psi		
3	7	6.00 in. x 5.99 in.	8450 lb	Middle third	707 psi		
Average	7				660 psi	10.2	
4	14	5.97 in. x 6.01 in.	8300 lb	Middle third	687 psi		
5	14	6.03 in. x 6.00 in.	7800 lb	3.9 in. from support	–	–	Disregard
6	14	6.01 in. x 5.99 in.	8450 lb	Middle third	705 psi		
Average					695 psi	10.8	
7	21	5.98 in. x 6.01 in.	10,500 lb	Middle third	875 psi		
8	21	6.04 in. x 5.98 in.	10,000 lb	Middle third	833 psi		
9	21	5.97 in. x 6.01 in.	8450 lb	5.3 in. from support	623 psi	–	Δ too great
Average					855 psi	13.3	
10	28	6.01 in. x 6.00 in.	10,600 lb	Middle third	882 psi		
11	28	6.03 in. x 5.99 in.	11,750 lb	Middle third	978 psi		
12	28	5.98 in. x 5.99 in.	9250 lb	Middle third	775 psi		
Average					880 psi	13.6	

Figure 2-18: Illustrative example

Date specimens were cast: _____ ; Comments: _____							
Description of test specimens: _____ ; Distance between supports: _____							
Specimen No.	Days Cured	Average $b \times d$ cm or in.	Load kg/lb	Location of Fracture	M.R. MPa/psi	% f'_c	Remarks
1							
2							
3							
Average							
4							
5							
6							
Average							
7							
8							
9							
Average							
10							
11							
12							
Average							

Figure 2-19: Data sheet

Chapter Three: Job Mix Design (Developed from ACI and British Standard)

3.1. Purpose

The overall aim of this experiment is to describe how the economical mix design concrete can be carried out.

3.2. Introduction

The proportioning of concrete mixtures is the process of arriving at the right combination of cement, aggregates, water, and admixtures for making concrete according to given specifications. For reasons described below, this process is considered an art rather than a science. Although many engineers do not feel comfortable with matters that cannot be reduced to an exact set of numbers, with an understanding of the underlying principles and, with some practice, the art of proportioning concrete mixtures can be mastered. Given an opportunity, the exercise of this art is very rewarding because the effect of mix proportioning on the cost of concrete and several important properties of both fresh and hardened concrete can be clearly seen.

One purpose of mix proportioning is to obtain a product that will perform according to certain predetermined requirements. Conventionally, the two most essential requirements are the workability of fresh concrete and the strength of hardened concrete at a specified age. Workability is the property that determines the ease with which a concrete mixture can be placed, compacted, and finished. Durability is another important property, but it is generally assumed that under normal exposure conditions durability will be satisfactory if the concrete mixture develops the necessary strength. Of course, under severe conditions, such as freeze-thaw cycles or exposure to sulfate water, the proportioning of concrete mixture will require special attention.

Another purpose of mix proportioning is to obtain a concrete mixture satisfying the performance requirements at the lowest possible cost. This involves decisions regarding the selection of ingredients that are not only suitable but also available at reasonable prices. The overall objective of proportioning concrete mixtures can therefore be summarized as selecting the suitable ingredients among the available materials and determining the most economical combination that will produce concrete with certain minimum performance characteristics.

The tools available to the engineer to achieve this objective are limited. An obvious constraint in concrete mixture proportioning is that within a fixed volume you cannot alter one component independent of others. For example, in a cubic meter of concrete, if the aggregate component is increased, the cement paste component decreases. With concrete-making materials of given characteristics and with given job conditions (i.e., structural design, and equipment for handling

concrete), the variables generally under the control of a mix designer are as follows: the cement paste-aggregate ratio in the mixture, the water-cement ratio in the cement paste, the sand-coarse aggregate ratio in the aggregates, and the use of admixtures.

The task of mixture proportioning is complicated by the fact that certain desired properties of concrete may be oppositely affected by changing a specific variable. For example, the addition of water to a stiff concrete mixture with a given cement content will improve the flowability of fresh concrete but at the same time will reduce the strength. In fact, workability itself is composed of two main components [i.e., consistency (ease of flow) and cohesiveness (resistance to segregation)], and both tend to be affected in an opposite manner when water is added to a given concrete mixture. The process of mixture proportioning boils down to the art of balancing various conflicting requirements.

3.3. Basic Considerations

Before discussing the specific principles underlying the procedures commonly used for mixture proportioning, let us examine some of the general considerations such as cost, workability, strength, and durability of concrete.

3.3.1. Cost

The most obvious consideration when choosing concrete-making materials is that they are technically acceptable and, at the same time, economically attractive. In other words, when a material is available from two or more sources and a significant price differential exists, the least expensive source of supply is usually selected unless there are demonstrable technical reasons that the material will not be suitable for the job at hand.

In spite of the usually small differences in the price of aggregates from various local sources, the overall savings for a large project are worthy of consideration. Assume that a concrete mixture composed of 1800 kg/m³ of total aggregate is required for a 6 million cubic meter concrete job, and that the two sources capable of furnishing suitable aggregates have a 10-cent/tonne price difference between them. A simple computation will show that a cost saving of over \$1 million is possible if the less expensive aggregate is selected.

A key consideration governing many of the principles behind the procedures for proportioning concrete mixtures is the recognition that cement costs much more than aggregates; therefore, all possible steps should be taken to reduce the cement content of a concrete mixture without sacrificing the desired performance characteristics of concrete, such as strength and durability.

3.3.2. Workability

Workability of fresh concrete has a direct effect on the pumpability and constructability because it determines the ease with which a concrete mixture can be handled without harmful

segregation. In all likelihood, a concrete mixture that is difficult to place and consolidate will not only increase the cost of handling but will also have poor strength, durability, and appearance. Similarly, mixtures prone to segregate and bleed are more expensive to finish and will yield less durable concrete. Thus, workability can affect both the cost and the quality of concrete mixtures. However, there is a problem. The term workability represents many diverse characteristics of fresh concrete that are difficult to measure quantitatively. This is another reason why the proportioning of concrete mixtures for a desirable but not fully definable measure of workability remains an art as well as a science. Clearly, mere knowledge of mixture design procedures is not sufficient without an understanding of the basic principles involved. General considerations guiding the workability of concrete mixtures are as follows:

- The consistency of concrete should be no more than necessary for the ease of placing, compaction, and finishing.
- The water requirement for a given consistency increases with both sand/coarse aggregate ratio and the amount of fines in the sand. Whenever possible, the cohesiveness and finishability of concrete should be improved by increasing the sand/coarse aggregate ratio alone rather than by increasing the proportion of fine particles in the sand.
- For concrete mixtures requiring high consistency at the time of placement, the use of water-reducing and set-retarding admixtures should be considered rather than the addition of extra water at the job site; water that has not been accounted for in the mixture proportioning is frequently responsible for the failure of concrete to perform according to design specifications.

3.3.3. Strength and durability

Strength and impermeability of hydrated cement pastes are mutually related through capillary porosity, which is controlled by the water-cement ratio and the degree of hydration. With the exception of frost resistance, the durability of concrete is generally controlled by permeability. Consequently, in routine mix designing operations only the workability and strength of concrete are specified; consideration of durability is ignored unless special environmental exposures require it. With normally available cements and aggregates, structural concretes of consistency and strength adequate for most purposes, that is, 100- to 150-mm slump and 20 to 40 MPa 28-day compressive strength, can be produced without any difficulty. When strength or durability considerations require a lower water-cement ratio, this is generally achieved by lowering the water demand at a given cement content through control of the aggregate grading and the use of water-reducing admixtures. This approach not only is more economical but also would reduce the chances of cracking due to high thermal shrinkage and high drying shrinkage when the water-cement ratio is lowered by using a high cement content.

3.3.4. Ideal aggregate grading

Considerations of cost, workability, strength, and durability may lead to the assumption that the most dense aggregate packing with a minimum content of voids will be the most economical

because it requires the least amount of cement paste. This assumption has led to a number of theoretical studies on the packing density of granular materials, which is defined as the solid volume in a unit total volume. The objective of such studies has been to obtain mathematical expressions or ideal grading curves that help determine the ideal combination of different size fractions of aggregate particles to produce the minimum void space. De Larrard¹ provides an excellent review of models to predict the packing density of granular mixtures. Besides being uneconomic, the use of ideal aggregate grading is not prevalent in concrete field practice because often it does not produce the best workability. In the United States, the grading limits specified by ASTM C 33 are usually followed. Not only they are broad and therefore economically attractive, but also are based on practical experience with a large number of concrete mixtures. Using aggregates outside the limits of ASTM C 33 have caused workability problems and produced large voids in concrete. However, using aggregates that meet the requirements of ASTM C 33 may not necessarily produce satisfactory concrete mixtures because the grading limits happen to be too broad to guarantee optimum packing density. Shilstone² reported that combined mixture containing the coarse and the fine aggregates is often deficient of particles in the size range 4.75 to 9.5 mm. This can be remedied by substituting a portion (e.g., 15 to 30 percent by mass) of the coarse aggregate with pea-size (4.75 to 9.5 mm) gravel or crushed rock.

3.4. Specific Principles

When reviewing the following specific principles for selecting concrete mixture proportions, it will be helpful to remember again that the underlying goal is to strike a reasonable balance between the workability, strength, durability, and cost of concrete.

3.4.1. Workability

As already stated, workability embodies certain characteristics of fresh concrete, such as consistency and cohesiveness. Consistency, broadly speaking, is a measure of the wetness of the concrete mixture, which is commonly evaluated in terms of slump (i.e., the wetter the mixture, the higher the slump). If the water content is a key factor affecting the cost economy, it should be noted that there is almost a direct proportionality between the slump and the water content, with a given set of materials. To obtain the specified slump, the mixture water requirement generally decreases as: (1) the maximum size of a well-graded aggregate is increased; (2) the content of angular and rough-textured particles in the aggregate is reduced; (3) the amount of entrained air in the concrete mixture is increased; and (4) coal fly ash is used as a partial replacement for a cement.

Cohesiveness is a measure of compactibility and finishability, which is generally evaluated by trowelability and visual judgment of resistance to segregation. In trial mixtures when cohesiveness is judged as poor, it can usually be improved by taking one or more of the following steps: increase the sand/coarse aggregate ratio, partially replace the cement or sand with coal fly ash, and increase the cement paste/aggregate ratio. Obviously, due to its lower

density, fly ash has the ability to increase the cement mortar/aggregate ratio by volume without an increase in the cement, water, or sand content of the mixture.

As the slump of fresh concrete is a measure of the ease with which the concrete mixture flows during the placement, and as the test for slump is simple and quantitative, most *mix-design procedures rely on slump as a crude index of workability*; it is assumed that mixtures containing adequate cement content (with or without mineral admixtures) and well-graded aggregate will have a satisfactory degree of cohesiveness. It should be noted that several laboratory trial mixtures are usually necessary before arriving at a qualitative notion of workability judged as satisfactory for a given job. Due to differences in equipment, further adjustment in the mixture proportions may be needed after a field trial or after some experience with full-size batch leads. This is yet another reason why past experience is recognized as so important in concrete mix-proportioning. It is worth mentioning here that there are no standard requirements for workability because they may vary from one job to another, depending on the type of construction and the equipment used to transport and consolidate concrete. For example, the workability of concrete desired for a slip-formed unreinforced pavement will not be the same as for a congested reinforced column, and the workability desired for pumped concrete in a high-rise structure will not be the same as for mass concrete placed by crane or belt conveyor.

3.4.2. Strength

From the standpoint of structural safety, the strength of concrete specified by the designer is treated as the minimum required strength. Therefore, to account for variations in materials; methods of mixing, transportation, and placement of concrete; and curing and testing of concrete specimens, ACI Building Code 318 requires a certain degree of strength overdesign, which is based on statistical considerations. In other words, depending on the variability of test results, the mixture proportions selected must yield a mean or average strength higher than the minimum or the specified strength. It should be noted that the average strength, not the specified strength, is used in mixture design calculations.

Although other factors also influence strength, the tables and charts used for the purposes of mixture proportioning assume that strength is solely dependent on the water-cement ratio and the content of entrained air in concrete. A more accurate relationship between the strength and water-cement ratio for a given set of materials and conditions may be available from past experience or should be developed from trial mixtures. Depending on the moisture state of the aggregate, corrections in the amounts of mixing water, sand, and coarse aggregate are necessary to make sure that the water-cement ratio in the concrete mixture is correct.

3.4.3. Durability

As stated earlier, when concrete is subject to normal conditions of exposure, the mix-proportioning procedures ignore durability because strength is considered to be an index of

general durability. However, under conditions that may tend to shorten the service life of concrete, its durability may be enhanced by special considerations in mixture proportioning. For example, entrained air is required with all exposed concrete in climates where freezing and thawing cycles occur. Concrete exposed to chemical attack by deicing salts or acidic or sulfate waters may require the use of water-reducing and mineral admixtures. In such a situation, although a higher water-cement ratio would have satisfied the strength requirement, a lower water-cement ratio is usually specified considering the exposure conditions.

3.5. Procedures

A concrete mix design can be proportioned from existing statistical data using the same materials, proportions, and concreting conditions. When there are no existing records or they are insufficient, the concrete mixture must be determined by trial mixtures. In a laboratory class situation, no body of field experience with the materials is assumed to exist. In concrete proportioning by the method of trial mixtures, certain design objectives must be established beforehand. These are as follows:

- Required 28-day compressive strength, f'_c or some other strength parameter such as the modulus of rupture.
- Portland cement content based upon water/cement (w/c) ratio and under certain conditions the minimum specified cement content.
- Maximum allowable water/cement ratio.
- Maximum size of the large aggregates.
- Acceptable range of slumps and the percent of air for an air-entrained concrete.

Once these parameters have been established, trial mixes can then be formulated and the specimens prepared. In practice, three mixtures would be prepared with three specimens each. A water/cement (w/c) ratio would be determined from reference tables for one-mix design. Other mix designs would then be computed somewhat above and below the first w/c ratio. However, as you will note, the highest w/c ratio must never exceed a certain limiting value that is obtained from an appropriate table for the particular structure and environmental conditions. The three mixes should produce a range of strengths (f'_{cr}), be within the specified slump ± 20 mm (3/4 in.) and at an air content $\pm 0.5\%$ of the maximum permitted. f'_{cr} will be defined twice later in this section. Each test consists of three specimens. In practice the w/c ratio as the abscissa is plotted against the strength as the ordinate. From the resulting curve a w/c is taken off at the desired f'_{cr} . The difference between f'_c and f'_{cr} is explained later in this section. Several proportioning methods are available. The one that will be described in this book is based on the absolute volume method from the American Concrete Institute's Committee 211, "Standard Practice for Selecting Proportions for Normal, Heavyweight and Mass Concrete." In order to use this method, certain physical properties of the materials need to be determined in the laboratory before designing the mixtures. These are as follows:

- Apparent specific gravity of the portland cement.
- Bulk specific gravities and percent of moisture present in the saturated surface dry (SSD) condition for both the coarse and fine aggregates.
- Rodded unit weight of the coarse aggregates.
- Fineness modulus of the fine aggregates.
- Free moisture present in both the coarse and the fine aggregates.

<i>Sieve Size</i>	<i>Percentage of Individual Fraction Retained by Weight</i>	<i>Cumulative Percentage Passing by Weight</i>	<i>Cumulative Percentage Retained by Weight</i>
9.5 mm (3/8 in.)	0	100	0
4.74 mm (No.4)	2	98	2
2.36 mm (No.8)	13	85	15
1.18 mm (No.16)	20	65	35
600 m (No.30)	20	45	55
300 m (No.50)	24	21	79
150 m (No.100)	18	3	97
Pan	3	0	–
Total	100		283

$$\text{Fineness Modulus} = 283/100 = 2.83$$

Figure 3-1: Example of a fineness modulus computation

The term fineness modulus may be used to define either a coarse or a fine aggregate in accordance with ASTM Designation: C 125. However, in this book reference will only be made to the fineness modulus (FM) for the fine aggregate. The FM is a factor obtained by adding the percentage of material in the sample that is coarser than each of the following sieves (cumulative percentage retained) and dividing the sum by 100. The computation is illustrated in Figure 3-1.

In describing the mix design procedure it will be necessary to consider the same absolute volume method separately for both systems of measurements. The size of the design batch for the S.I. system will be the cubic meter, while for the U.S. Standard System of Measurements it will be the cubic yard. Two other values that need to be considered in trial mix proportioning are the unit weight and the yield. The unit weight of freshly mixed concrete is expressed in a weight per volume while the yield is calculated by dividing the total weight of all the materials batched by the unit weight of the freshly mixed concrete. The term batch is not unique to concrete works. It is simply the quantity of materials required for a single operation. To produce concrete of uniform quality the materials must be accurately introduced into the mixer by mass or weight, depending upon the system of measurements used. However, a one cubic meter batch or a one cubic yard batch does not mean that the resultant quantity produced is exactly one cubic meter or one cubic yard. The reason for that is the variability in yield. Concrete should be thoroughly mixed until a uniform appearance is obtained. All concrete specimens in the laboratory should be prepared in accordance with ASTM Designation: C 192 which is included in this book. Concrete

mixers, whether stationary or mobile, have a rated maximum capacity and rotational speed. These provisions of the equipment manufacturer should be followed. Generally the maximum recommended mixing quantity is about 57.5% of the volume of the drum. Shrink mixing, a method of overloading the drum, is poor practice and should not be permitted.

The various tables that are introduced for the mix design computations were taken from the PCA Engineering Bulletin, Design and Control of Concrete Mixtures, from both the U.S. and Canadian editions. In some instances the tables were modified to facilitate their use in the book for application to concrete mix designs in either the S.I. or U.S. Standard Systems of measurements. Where it was not deemed practical to use the same table for both systems of measurements, the tables were introduced separately under the respective mix design methods for each system. Tables 3-1, 3-2, 3-3 and 3-4 were modified to be applicable to both measurement systems. The other necessary tables are included under the discussion for each of the two systems of measurements. Tables 3-1, 3-2 and 3-3 are self explanatory and their use will be illustrated in the design examples shown under each of the two systems of measurements. However, Table 3-4 requires a little explanation. When there exists a body of data for the particular materials and mix design, a standard deviation is computed. This standard deviation is introduced into two equations that in turn yield a modification factor. In effect, the design objective then becomes to prepare a concrete with a compressive strength of f'_{cr} , which is greater than the specified design concrete strength f'_c . Since there are variations in the results obtained in any concrete, the objective is to design the most economical mix that will still result in a high degree of assurance that the concrete will not be less than f'_c . Since in a teaching laboratory each group starts off at time zero, there is no assumed existing body of data and, therefore, Table 3-4 will be used. There are other refinements in developing the ultimate f'_{cr} that will not be introduced in this book because a classroom environment does not permit the amount of time required for the more detailed procedure. For further information, the reader is referred to the appropriate chapter in the applicable Portland Cement Association (PCA) Design and Control of Concrete Mixtures and the Recommended Practice for Evaluation of Strength Test Results of Concrete by the ACI Committee 214 Report. What follows is an explanation of the proportioning of normal weight and strength concrete mixtures by the absolute volume method for both the S.I. and the U.S. Standard systems of measurement. Several of the mix design tables that could not be accommodated for both of the systems of measurements simultaneously, are shown separately in Tables 3-5 through 3-8.

With regards to Table 3-5 (Volume of Coarse Aggregate Per Unit Volume of Concrete), a modification is sometimes used. In structures, where there is less demand for workability, such as in concrete flatwork (pavements being a prime example), the quantity of coarse aggregates may be increased by about 10%. Conversely, when more workability is required such as in a pumpcrete, the quantity of coarse aggregates are generally decreased by a similar amount. This factor will be used in the illustrative example for concrete mix design. A relationship exists between the compressive strength of a concrete and its flexural strength, both taken at 28 days.

While the connection between the two values are far from precise, it is sufficiently valid for initial mix design purposes. However, before the design is used, its flexural strength adequacy should be tested. The w/c ratio should be adjusted, up or down, in order to obtain the most economical concrete mix that satisfies the other requirements. The approximate corresponding compressive strength for a given flexural strength can be derived from the following equations:

$$f'_c = \left(\frac{MR}{K}\right)^2 \text{ --- In MPa for the S.I. system}$$

$$K=0.7 \text{ to } 0.8$$

$$f'_c = \left(\frac{MR}{K}\right)^2 \text{ --- in psi for the standard U.S. system}$$

$$K=7.5 \text{ to } 10$$

MR stands for modulus of rupture, which is the flexural strength based upon ASTM Designation: C 78. The higher K-values are applicable for the stronger the concretes. These equations will be used in the illustrative examples, with K = 0.8 and 10.

Exposure Condition	Maximum W/C Ratio by Weight for Normal Weight Concrete
Concrete protected from exposure to freezing and thawing or the application of deicer chemicals	Select the w/c ratio on the basis of strength, workability, and finishing needs
Concrete intended to be watertight: <ul style="list-style-type: none"> • Concrete exposed to fresh water • Concrete exposed to brackish water or sea water 	0.5 0.45
Concrete exposed to freezing and thawing in a moist condition ^a : <ul style="list-style-type: none"> • Curbs, gutters, guardrails, or other thin sections • Other elements • In the presence of deicing chemicals 	0.45 0.5 0.45
For corrosion protection for reinforced concrete exposed to deicing salts, brackish water, sea water, or spray from these sources	0.4

^a Air-entrained concrete.

Table 3-1: Maximum Water Cement Ratio for Various Exposure Conditions

Maximum Size of Aggregate, mm (in.)	Volume of Rodded Coarse Aggregates per Unit Volume of Concrete for Different Fineness Moduli of Fine Aggregates as per ASTM Designation: C 29 ^a			
	2.40	2.60	2.80	3.00
9.5 mm (3/8 in.)	0.5	0.48	0.46	0.44
12.5 mm (1/2 in.)	0.59	0.57	0.55	0.53
19 mm (3/4 in.)	0.66	0.64	0.62	0.60
25 mm (1 in.)	0.71	0.69	0.67	0.65
37.5 mm (1.5 in.)	0.75	0.73	0.71	0.69
50 mm (2 in.)	0.78	0.76	0.74	0.72
76 mm (3 in.)	0.82	0.80	0.78	0.76

^a Volume of either dry- or SSD-rodded. It is important to differentiate in computing the adjusted moisture content for the concrete mix.

Table 3-2: Volume of Coarse Aggregate Per Unit Volume of Concrete as per ASTM Designation: C 29

Concrete Construction	Slump in mm (in.)	
	Maximum	Minimum
Reinforced foundation and footings	75 mm (3 in.)	25 mm (1 in.)
Plain footings, caissons, and substructure walls	75 mm (3 in.)	25 mm (1 in.)
Beams and reinforced walls	100 mm (4 in.)	25 mm (1 in.)
Building columns	75 mm (3 in.)	25 mm (1 in.)
Pavements and slabs	75 mm (3 in.)	25 mm (1 in.)
Mass concrete	50 mm (2 in.)	25 mm (1 in.)

Table3-3: Recommended Slumps for Various Types of Construction

Specified Compressive Strength, f'_c , MPa (psi)	Required Average Compressive Strength, f'_{cr} , MPa (psi)
Less than 20 MPa (3000 psi)	$f'_c + 6.9$ MPa (1000 psi)
20 to 35 MPa (3000 – 5000 psi)	$f'_c + 8.3$ MPa (1200 psi)
Over 35 MPa (5000 psi)	$f'_c + 9.6$ MPa (1400 psi)

Table 3-4: Required Average Compressive Strength When Data is Not Available to Establish a Standard Deviation

Maximum Size of Aggregates (mm)	Portland Cement ^a (kg/m ³)
40	282
20	324
14	354
10	366

^a Cement quantities need to be increased in cases of severe environmental conditions such as for tremie concrete (concrete placed under water) to $\geq 390 \text{ kg/m}^3$, or for a very cold climate where the concrete is subject to freezing and thawing cycles; the cement content should be $\geq 335 \text{ kg/m}^3$.

Table 3-5: Minimum Portland Cement Requirements for Normal-Density Concrete Placed in Slabs and Pavements

3.5.1. The International System of Measurements

Illustrative Problem for Concrete Mix Design by the Absolute Volume Method

- **Design parameters**

Design the concrete for an unreinforced, air entrained pavement in a very cold climate; there is no statistical data available for the proposed mix design; 25 cm thick; specified 28-day concrete flexural strength of 4.7 MPa; the coarse aggregates have a bulk specific gravity of 2.70; a rodded density of 1650 kg/m^3 at the saturated surface dry (SSD) condition, and a moisture content of 1.5% above the SSD condition; the fine aggregates have a bulk specific gravity of 2.65 with a fineness modulus of 2.75 and a moisture of 5% above the (SSD) condition. The apparent specific gravity of the Portland cement = 3.15.

- **Design Solution**

For structural concrete the required compressive strength is specified. Only in the case of pavements is the flexural strength criterion used instead. However, since the mix design tables are predicated on compressive strength, Equation 1 is used to determine the approximate equivalent compressive strength, f'_c .

$$f'_c = \left(\frac{MR}{0.8}\right)^2 = \left(\frac{4.7}{0.8}\right)^2 = 34.5 \text{ MPa}$$

Step 1

Determine the required mix design strength, f'_{cr} , from Table 3-4 = $34.5 + 8.3 = 42.8$ MPa.

Step 2

This is the estimated w/c ratio from Table 3-6. Since the table does not show the w/c ratio beyond a strength of 35 MPa, an estimate was made to specify a 0.35 w/c ratio which is very low. In practice a water reducing or superplasticizer additive very likely would have to be added in order that the concrete mix is sufficiently workable at the 0.35 w/c ratio. Check Table 3-1 to assure that the maximum w/c ratio is not exceeded. However, because of the fairly high percent of entrained air the mix may still prove to be sufficiently workable. Only after the trial batch is prepared and the slump measured will the engineer (or the student) know what modifications needs to be made to the mix for workability. It is simply too complex and time consuming a subject to cover in an undergraduate laboratory course. The student does not have the time to go back and adjust the mix because of the 28-day strength. In the case of an air-entrained concrete, the student will only be able to adjust the slump by changing the w/c ratio and the percent of entrained air. Check whether the cement content equals or exceeds the recommended quantity shown in Table 3-5, if applicable to the design structure.

Compressive Strength at 28 Days, MPa.	Water/Portland Cement Ratio by Mass	
	Nonair-Entrained Concrete	Air-Entrained Concrete
40	0.42	-
35	0.47	0.39
30	0.54	0.45
25	0.61	0.52
20	0.69	0.60
15	0.79	0.70

Table 3-6: Approximate Relationship Between W/C and the Concrete Compressive Strength

Air Content Category ^a	Range of Air Content in Percentage at Indicated Nominal Maximum Sizes of Coarse Aggregates		
	10 mm	14-20mm	28-40mm
1	6-9	5-8	4-7
2	5-8	4-7	3-6

^a Category 1 is for concrete exposed to freezing and thawing. Category 2 is for concrete not exposed to freezing and thawing.

Table 3-7: Air Content Requirements by Category

Step 3

In selecting the maximum size of coarse aggregate, there are a number of criteria that need to be met. They will all be enumerated here even though not all are applicable in this illustrative design problem. The criteria for the maximum permissible size of aggregate are as follows:

- Not to exceed one fifth the narrowest dimension between the insides of a form.
- Three quarters of the clear space between reinforcing bars, ducts, or any other appurtenances embedded in the concrete.
- Three quarters of the clear space between the reinforcing bars and the inside face of the forms.
- In the case of an unreinforced concrete slab, one third the minimum slab thickness, where the concrete is not uniform in depth.

There are several other less frequently encountered criteria which will not be enumerated here. It is generally most economical to specify the largest coarse aggregate size practical for the design conditions. In the case of the 25 cm pavement thickness, this would translate to 75 mm aggregate, which is on the high side, but if available and economical, should be used. Generally speaking, a 50 mm aggregate is the largest size that is commonly encountered. For this design exercise the 75 mm maximum size stone will be specified. Furthermore, in the case of a paving concrete, it is desirable to specify a crushed gravel because of the need for maximum traction between the pavement surface and the vehicles.

Step 4

The air content depends principally upon the environment under which the structure will be functioning. Refer to Table 3-7. The structure in this problem would qualify as a Category 1, exposed to freezing and thawing, for an air content of 4 to 7%. Table 3-8 indicates a target percent of entrained air at 4.5, which is in the 4 to 7% range shown on Table 2-7. For many reasons, it is not possible to specify and expect to repeatedly obtain

an exact percent of air. Furthermore, the author is of the opinion that slightly more air is preferable to less air. Therefore, a target percent air will be chosen: -1% to $+2\%$. In the case of this illustrative design example, a target percent air of 5% (-1% to $+2\%$) for a range of 4 to 7% was chosen.

Slump (mm)	Water Per kg/m ³ of Concrete for Indicated Maximum Size of Aggregate in mm ^a			
	10	20	40	80
Nonair-Entrained Concrete				
25–50	207	190	166	130
75–100	228	205	181	145
150–175	243	216	190	160
Approximate % entrained air	3	2	1	0.3
Air-Entrained Concrete				
25–50	181	168	150	122
75–100	202	184	165	133
150–175	216	197	174	154
Recommended Percent Air for Level of Exposure	Slumps for concrete with aggregates larger than 40 mm are made after the removal of the +40 mm particles by <u>wet screening</u>			
Mild exposure	4.5	3.5	2.5	1.5
Moderate exposure	6.0	5.0	4.5	3.5
Severe exposure	7.5	6.0	5.5	4.5

^a The water estimates in the above table are for angular crushed stone. The quantities may be reduced by about 10 kg for subangular coarse aggregates, 20 kg for gravel with some crushed particles, and 25 kg for rounded gravel to produce the slumps shown. A change in water content by 2 kg/m³ will affect the slump by about 10 mm. Of course, an increase in water will raise the slump and conversely a decrease in air content by 1% will increase water demand for the same slump by about 3 kg/m³.

Figure 3-8: Approximate Water and Air Content Requirements for Various Slumps and Maximum Size Aggregates in the Concrete Mix

Step 5

The desired concrete slump must be specified. For this purpose refer to Table 3-3 which shows 2.5 to 7.5 cm.

Step 6

Compute the quantities for the 1 m³ trial batch and then an adjustment will be made, taking into consideration the yield of the resultant concrete mix. First, the amount of air-entraining agent, which is usually a liquid made from wood resin, sulphonated hydrocarbons, fatty and resinous acids, or synthetic materials, is determined from the manufacturers' specifications. Usually it is in terms of an amount per 100 kg of portland cement in the mix for each additional percent of entrained air desired. The total quantity is never enough to significantly affect the overall volume of mixing materials. Coarse aggregate quantity is estimated from Table 3-2, bearing in mind the maximum size of coarse aggregates and the fineness modulus of the fine aggregates. In the case of this illustrative problem, they are 7.5 and 2.75 cm, respectively. This results in an interpolated volume of dry-rodded coarse aggregates of 0.78.

Slump from Table 3-3 shows 2.5 to 7.5 cm. Water content from Table 11 = 122 kg/m³, using the lower slump of 2.5 to 5.0 cm and the more desirable range from the author's experience in slipform paving operations. Cement content based upon w/c ratio of 0.35 = 122/0.35 = 349 kg/m³. Referring to Table 2-5, the minimum recommended Portland cement content for this mix is 335 kg. Table 2-1 permits a w/c ratio of 0.45 for this concrete. Therefore, the design w/c ratio and design cement quantity is satisfactory for the trial mix. Coarse aggregates were found to have a rodded SSD condition density of 1650 kg/m³. For a m³ batch of concrete, the required weight of coarse aggregates = 0.78 × 1650 = 1287 + 10% (as explained Before) = 1416 kg.

At this point the quantity of all the materials in the mix has been accounted for except for the fine aggregates. The latter is found by subtracting the volume of the air, cement, coarse aggregates, and water from a cubic meter to estimate the fine aggregate quantity in the batch.

Air	=	0.05	=	0.050m ³
Cement	=	349/(3.15×1000)	=	0.111 m ³
Coarse aggregate	=	1416/(2.70×1000)	=	0.524m ³
Water	=	122/(1×1000)	=	0.122m ³
Total Volume	=			0.807m ³

Computed volume of fine aggregates = 1.000 – 0.807 = 0.193 m³

Weight of fine aggregates in the concrete batch = $0.193 \times 2.65 \times 1000 = 511 \text{ kg}$

Total weight of all the ingredients in the 1 m^3 concrete batch = 349 kg (cement) + 1416 kg (coarse aggregates) + 511 kg (fine aggregates) + 122 kg (water) = 2,398 kg. A moisture correction at this point is needed to compensate for the moisture in the aggregates above that present for the SSD condition. The new trial batch weights are as follows:

Coarse aggregates	=	1416×1.015	=	1437kg
Fine aggregate	=	511×1.05	=	537kg
Water	=	$122 - 1416 \times 0.015 - 511 \times 0.05$	=	75kg
Cement			=	349kg

Total materials after water adjustment remains the same: 2398 kg

Assume that all the allotted water was used in the mixing process and that the slump and the air were within specified limits. Therefore, there need be no adjustment made in the ingredients. Otherwise changes would have to be made in total water, air-entraining agent, and possibly the need to introduce a water reducing additive. In the laboratory, mixes will normally be based batches made from 5, 10, or at the most 15 kg of Portland cement. For example, consider a 10 kg batch. The quantities would be as follows:

Cement			=	10kg
Coarse aggregates	=	$10/349 \times 1437$	=	41.2kg
Fine aggregate	=	$10/349 \times 537$	=	15.4kg
Water	=	$10/349 \times 75$	=	2.1kg

Total Weight of the batch = 68.7 kg

Two additional computations need to be made in order to adjust the batch to result in a 1 m^3 volume. These are the unit weight and the yield. From the 10 kg trial batch, a bucket of 0.025 m^3 was filled and weighed. The result was 61.1 kg or 2444 kg/m^3 . The latter value is designated as W. The actual weight of the materials computed for the 1 cubic meter batch is designated as W1. The yield is as follows:

$$Y = W1/W = 2398 \text{ kg}/2444 \text{ kg/m}^3 = 0.981 \text{ m}^3$$

Therefore, all of the quantities in the final mix need to be increased because the yield is less than 1. If the yield were greater than 1, the weight of the ingredients would have had to be decreased. The following is the final mix design adjustment, although, in the field, constant measurements need to be made in order to check the aggregates, unit weight of the freshly mixed concrete, and the yield:

Cement	=	349.0/0.981	=	356kg
Coarse aggregates	=	1437/0.981	=	1465kg
Fine aggregate	=	537/0.981	=	565kg
Water	=	75/0.981	=	76kg

Total Weight of final adjusted materials/m³ = 2462 kg

In the above computations the specific gravity of water is always assumed to be 1 and the density at 1 gm/cm³. The variation in this value because of temperature differentials is too insignificant for this type of work. The actual specific gravities of the Portland cement should be determined in the laboratory. However, if the specific gravity for the Portland cement has not been determined, a value of 3.15 may be used, probably without appreciable error. This was the approach that was taken in the computations for the illustrative concrete mix design problem. The specific gravities of other cementitious materials such as fly ash or silica fume, or other pozzolans must be determined in the laboratory or obtained from the producer. Their values will vary substantially from 3.15.

3.5.2. The system of Birzeit University for measurements (Developed from British standard)

- The material information such sieve analyses of both fine and coarse aggregate, specific gravities and absorption capacities of aggregate should be known.
- Choice of slump— generally specified for a particular job. If it is not given, appropriate value may be chosen from tables 2-2 or 3-3. As a general rule, the lowest slump which permit adequate placement should be selected.
- Maximum aggregate size— the largest maximum aggregate size that will conform to the following limitations:
 - Max. size should not be larger than 1/5th the min. dimension of structural members, 1/3rd the thickness of a slab or 3/4th the clearance between reinforcing rods and forms. These restrictions limit max. aggregate size to 1.5 inches, except in mass applications.

- Current thought suggests that a reduced max aggregate size for a given w/c ratio can achieve higher strengths. Moreover, in many areas, the largest available sizes are $\frac{3}{4}$ inch to 1in.
- Estimation of mixing water and air content- this can be obtained from table 3-9 which shows approximate mixing water for different slumps and nominal max sizes of aggregate

Aggregate		Water content, kg/m ³ (lb/yd ³) for:				
Max size	Type	Slump,mm	0-10	10-30	30-60	60-180
Mm(in.)		(in)	$(0-\frac{1}{2})$	$(\frac{1}{2}-1)$	$(1-2\frac{1}{2})$	$(2\frac{1}{2}-7)$
		Vebe time,s	>12	6-12	3-6	0-3
10($\frac{3}{8}$)	Uncrushed		150(255)	180(306)	205(345)	225(380)
	Crushed		180(306)	205(345)	230(390)	250(420)
20($\frac{3}{4}$)	Uncrushed		135(230)	160(270)	180(305)	195(330)
	Crushed		170(285)	190(320)	210(355)	225(380)
40($1\frac{1}{2}$)	Uncrushed		115(195)	140(235)	160(270)	175(295)
	Crushed		155(260)	175(295)	190(320)	205(345)

Table 3-9: Approximate free water contents to give various level of workability according to the 1988 British method

- w/c ratio– this component is governed by strength and durability requirements.
 1. Strength—without strength vs. w/c ratio data for a certain material, a conservative estimate can be made for accepted 28-day compressive strength from table 3-10 and figure 3-2.

Type of cement	Type of coarse aggregate	Compressive strength ^a (MPa (psi)) at the age of days:			
		3	7	28	91
Ordinary Portland (Type I)	Uncrushed	22(3200)	30(4400)	42(6100)	49(7100)
Sulfate-resisting Portland (Type V)	Crushed	27(3900)	36(5200)	49(7100)	56(8100)
Rapid-hardening Portland (Type III)	Uncrushed	29(4200)	37(5400)	48(7000)	54(7800)
	Crushed	34(4900)	43(6200)	56(8000)	61(8900)

^a Measured on cubes

Table 3-10: Approximate compressive strength of concretes made with a free w/c ratio of 0.5 according to the 1988 British method

2. Durability- if there is a severe exposure condition such as freezing and thawing, exposure to seawater, or sulfates, the w/c ratio requirements may have to be adjusted.

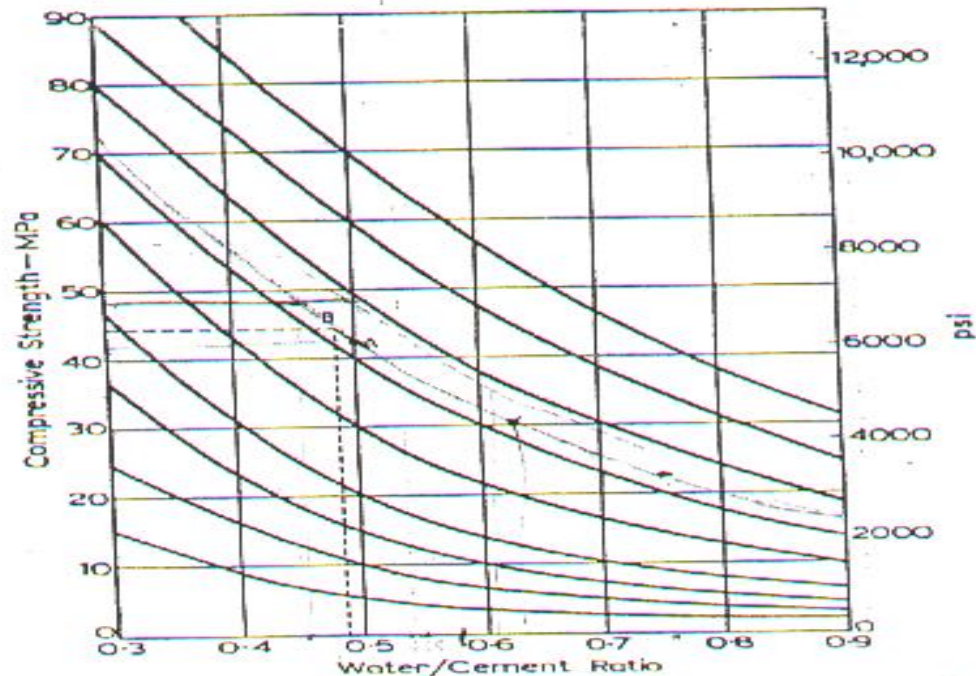

Figure 3-2: Relation between compressive strength and free water/ cement ratio for use in British mix selection method

- Calculation of cement content– once the water content and w/c ratio is determined, the amount of cement per unit weight of concrete is found by dividing the estimated water content by the w/c ratio. However, min cement content is required to ensure good finishability, workability, and strength.

$$\text{Weight of cement} = \frac{\text{weightOfWater}(kg)}{(w/c)}$$

At this stage check the weight of the cement with the minimum cement content which is given by the lab technician. If the Cement_{calculated} < Min cement, then use the min for the rest of calculations

- Estimation of aggregate content
The mass of the aggregate is found by subtracting the mass of cement, water, air from the total concrete density .
- Total concrete density is given by figure 3-3. You have to know the water content kg per m³ and the specific gravity of aggregate.

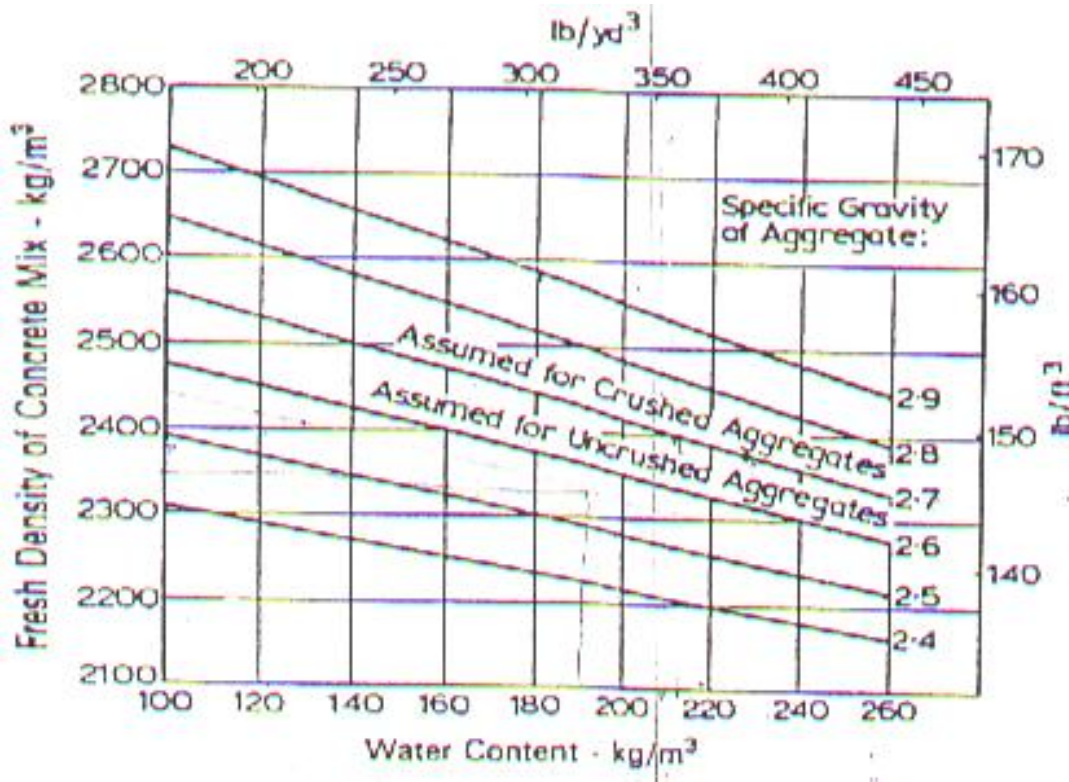

Figure 3-3: Estimated wet density for fully compacted concrete (specific gravity is given)

- Estimation of coarse and fine aggregate by two methods:
 - Using the information obtained from sieve analysis experiments which could be carried out by following steps:
 - The graphical method
 - A graph of the required aggregate is prepared by first drawing a rectangular box. Using the usual linear ordinates for percent passing, but choosing the scale of sieve size so that the grading plots as a straight line. This is readily done by drawing an inclined straight diagonal line and marking on it the sizes corresponding to the various percentages passing. The scale of this graph can be performed based on figure 3-4 below.
 - Sitting the percentages of each size of aggregates retained on each sieve for different types of aggregates used and joint each curve for the type of aggregate used ,then drawing tangent for each curve
 - The opposite ends of these tangent lines are joined together.
- The proportions for mixing purposes are read off from the points where these joining lines cross the straight line that joints the opposite ends of the rectangle .

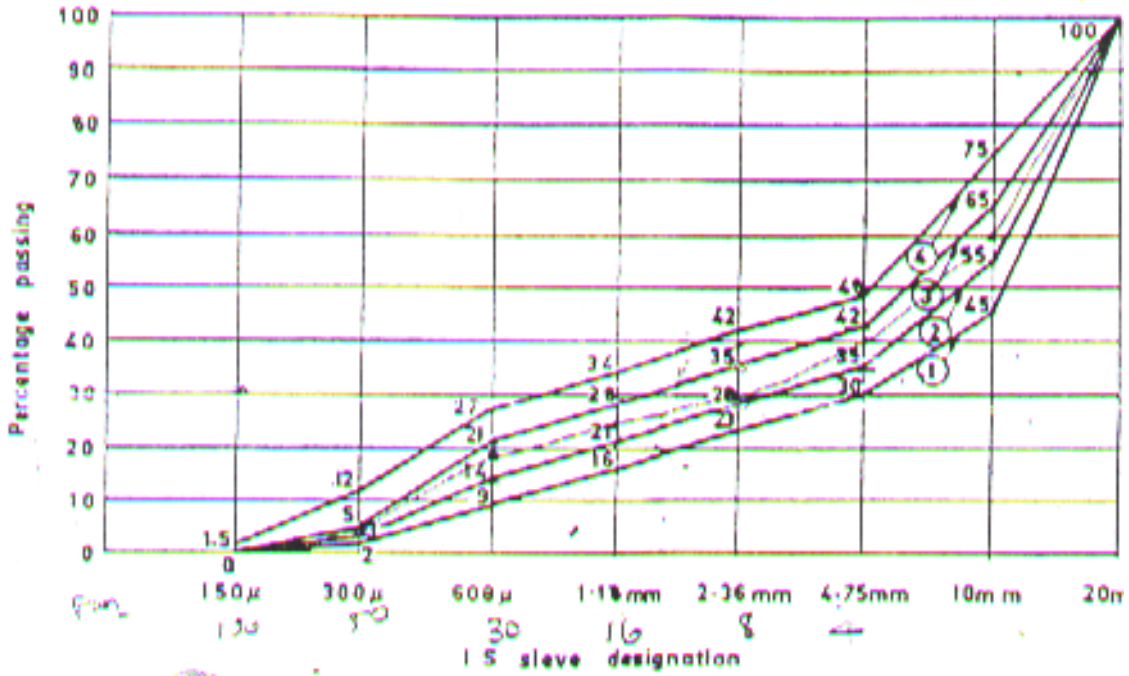

Figure 3-4: the graph used to carry out the new scale for students graphs

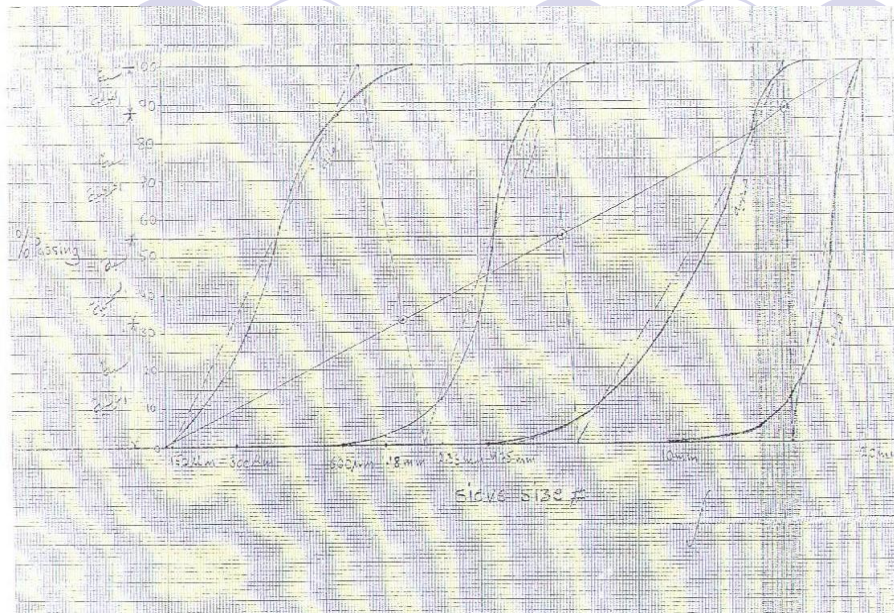

Figure 3-5: Example for the graph to be done by the students

- As well as the amount of various kinds of aggregates can be calculated using the following graphs and tables:

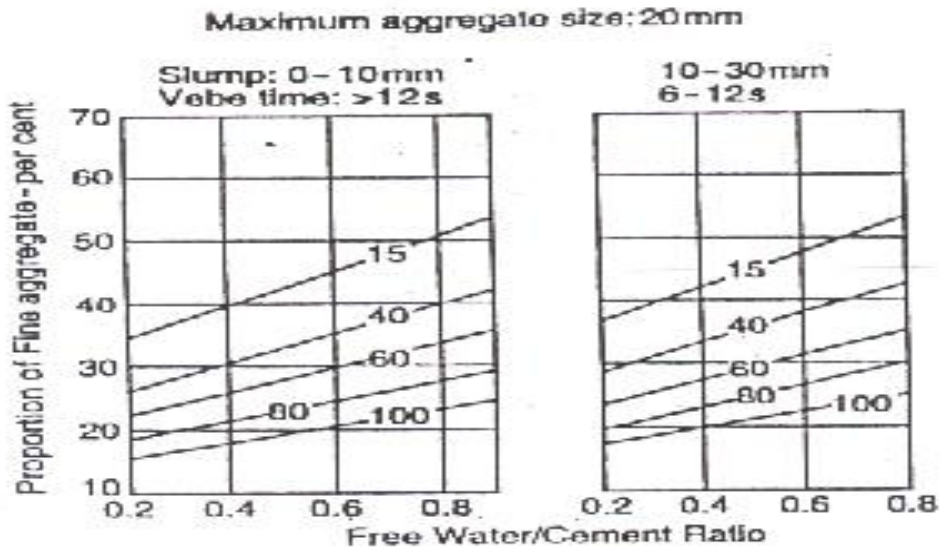

Figure 3-6:

Recommended proportion of fine aggregate as a function of free w/c ratio for various workabilities and maximum size.

- From the previous graph the proportion of fine aggregate is obtained, then the proportions of the coarse aggregate can be obtained via the following table

Total coarse aggregate	5-10mm	10-20mm	20-40mm
100	33	67	-
100	18	27	55

Table 3-11: Recommended proportion of Coarse aggregate

- Estimate the net quantities of water, cement and saturated surface dry aggregate that would be required in a trial mix, and make corrections for variations in the materials or the moisture content of aggregate.
- Since the aggregate to be used in the trial mix at BZU lab is air dried one, the amount of water for various kinds of aggregates have to be changed. I.e the amount of water have to be increased an amount equal to the effective absorption multiply by the weight of aggregate as SSD. See the following equations that should be used.

$$W_{abs} = (EA) \times (W_{agg.SSD})$$

Where: W_{abs} = the amount of water to be added

- EA: effective absorption of aggregate “as mentioned before”. Its value is calculated via the following equation:

$$EA = \left(\frac{W_{agg\ SSD} - W_{AD}}{W_{agg\ SSD}} \right) \times 100$$

- Where
 - $W_{agg\ SSD}$ is the weight of aggregates which is known through the mix design tables or figures.
 - W_{AD} = weight of aggregate as air dry.
- Finally the total amount of water to be added to the mix will be equal to: (W_{water} (known from job mix tables) + W_{abs}).
- Since the weight of the mix can not be changed, therefore the weight of air dried aggregates have to be adjusted according to the following equation:

$$\begin{aligned} W_{stockpile\ (airdry)} &= (W_{agg\ SSD} - W_{abs}) \\ &= W_{agg\ SSD} (1 - EA) \end{aligned}$$

- As well as, if the aggregates or part of them are wet the amount of water to be subtracted can be calculated via the following equations:

$$W_{given} = (SM) \times (W_{agg\ SSD})$$

- Where
 - SM= surface moisture
 - $W_{agg\ SSD}$ is the weight of aggregates which is known through the mix design tables or figures.

$$SM = \left(\frac{W_{wet} - W_{SSD}}{W_{SSD}} \right) \times 100$$

- Hence, the water to be added to the mix will be:

$$= (W_{water\ (from\ tables)} - W_{given})$$
- For the earlier mentioned reason, the weight of aggregates have to adjusted using the following equation:

$$W_{stockpile\ (wet)} = W_{agg\ SSD} (1 + SM)$$

- Make trail laboratory mixes and effect adjustments, as necessary to suit actual operating conditions.

Chapter Four: Air Content of Freshly Mixed Concrete by the Pressure Method

(Developed from ASTM Designation: C 231)

4.1. Introduction

By entrained air is meant that is intentionally introduced into concrete in the form of uniformly distributed bubbles in an appropriate amount to produce a desired interbubble spacing and resultant desirable effect. With regard to fresh concrete – air entrainment reduces mixing water requirement, increases plasticity, reduces bleeding and segregation and reduces unit weight.

Many factors affect the amount the air entrained, other conditions being equal and within practical limits, the air entrainment at the conclusion of mixing is greater for:

- 1- Greater amounts of air entrainment
- 2- More of the fine aggregates and leaner mixes
- 3- Smaller maximum size of aggregates from 1.5 and down
- 4- Wetter consistencies and less of finely divided mineral admixtures
- 5- Stronger mixing action and longer mixing
- 6- Lower temperature of concrete

There are various methods of determining the air content of fresh concrete which are :

- 1- Pressure method
- 2- Volumetric method
- 3- Gravimetric method

The most important and widely used method in addition to that it was the one used in this experiment is the pressure method which is carried out at BZU Laboratory

▪ The pressure method

It is based on the principle of Boyle's law that increases in pressure on a gas decreases its volume in proportion, the method makes use of the fact that in concrete only the air is compressible. Pressure is applied to a concrete sample and the reduction in volume is observed, the amount of air "entrained & entrapped" is then calculated or indicated by a calibrated gage. The air content is calculated by the following formula:

$$\text{Air content} = h_1 - h_2 - G$$

Where h_1 is the reading on column scale at air pressure 0.18

h_2 is the reading on column scale after releasing the air pressure

G the aggregate correction factor (0.03)

The method is applicable for concretes for those containing highly porous aggregates, in some cases, however, a correction for absorption and porosity can be determined by making a pressure test in a sample of the aggregates alone. The air meter consists of a bowl and a cover of being attached in order to form a rigid, pressure tight assembly. The cover is fitted with a graduated transparent tube, an air pump, and a pressure gage.

4.2. Purpose

The purpose is to determine the air content of freshly mixed concrete made with relatively dense aggregates by observing the change in volume of the concrete with a change in pressure.

4.3. Equipments and materials

- Air meters, types A (Figure 4-1)
- Steel trowel
- Funnel with a spout that can extend to the bottom of the top section
- Steel tamping rod 16 mm (5/8 in.) in diameter, rounded to a hemispherical shape at both ends
- Flat, steel strike-off at least $3 \times 20 \times 300$ mm ($1/4 \times 3/4 \times 12$ in.)
- Metal or plastic calibrated cup having a capacity at least equal to the volume of the bowl
- Rubber mallet about 0.60 kg (1.25 lb)
- Vibrator
- 37.5 mm (1 1/2 in.) sieve with a sieving area ≥ 0.19 m² (2 ft²).

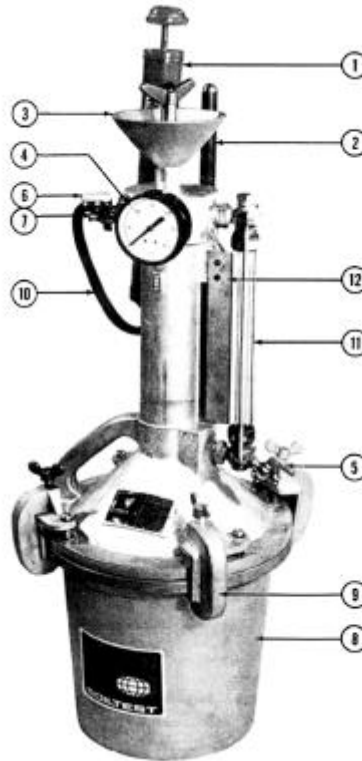

Figure 4-1: Diagram of a air meter: (1) hand pump, (2) tamping rod, (3) funnel and thumb valve, (4) pressure gauge, (5) petcock (drain), (6) petcock (air), (7) snifter valve, (8) container, (9) clamps and thumb screws, (10) hose attachment, (11) water glass, (12) graduated scale.
(Courtesy of ELE International, Inc., Soiltest Products Division, Lake Bluff, IL.)

4.4. Test procedures

1. An initial calibration should be performed on the meter used in accordance with the instructions included with the unit.
2. A determination needs to be made of the voids in the aggregates in order to deduct their volume from the measured air content of the concrete. This is called the aggregate correction factor. The steps are as follows:
 - a. Prepare separate samples of fine and coarse aggregates in the quantities which will be used in a volume of concrete that will exactly fill the container. The necessary weights of aggregates are computed as follows:

$$F_s = S/B \times F_b ; C_s = S/B \times C_b$$

- F_s = Quantity of fine aggregate in concrete sample (kg or lb)
- S = Volume of the measuring bowl in m^3 or ft^3
- B = Volume of concrete produced per batch, obtained in accordance with ASTM Designation: C 138, in m^3 or yd^3

- F_b = Quantity of saturated surface dry fine aggregate used in the batch in kg or lb
 - C_s = Quantity of coarse aggregate required for concrete sample in kg or lb
 - C_b = Quantity of saturated surface dry coarse aggregate used in the batch in kg or lb
- b. Fill the mixing bowl one third full of water. Add the mix of fine and coarse aggregates, F_s and C_s , as computed above, a small amount at a time. Deposit the aggregates so as to trap as little air as possible. Tap the sides of the bowl and lightly rod the top 2.5 cm (1 in.) of the aggregates 10 times. Also, stir after each addition of aggregates to eliminate entrapped air.
 - c. Proceed in accordance with the instructions for the particular air meter to determine the percent of air voids in the aggregates. This quantity is designated as “G” and it will be deducted from percent of entrained air of the sample tested.
3. Determine the percent of entrained air in the concrete sample, A1, by following the instructions accompanying the particular air meter in the laboratory. Of course, this air meter must meet the specifications for ASTM Designation: C 231 and it must be so stipulated in the accompanying instructional material.
 4. Following are representative type A air meter (Figure 4-1) along with detailed instructions for its use. Other manufacturers produce similar units, all meeting the ASTM Designation: C 231 specifications. Their instructions may contain certain differences which must be followed.

4.4.1. Operating Instructions for Determining Entrained-Air with a Air Meter

- **Determination of air in the aggregates:**
 - Fill the container about half full of water. Pour the fine aggregate slowly into the container and stir vigorously by hand, so that the aggregate will be completely inundated with no air entrapped around or between the particles. Note: Much care should be taken in performing this operation or the air entrapped between the particles will not be completely removed and the test will show erroneous results.
 - Fill the container with water. Wipe the contact surfaces clean and clamp the top section of the apparatus firmly in the container.
 - Close the petcock at the bottom of the water glass and open the petcock and funnel valve at the top. Fill the apparatus with water to a level slightly above the arrow mark on the graduated scale.
 - Close the funnel valve and adjust the water level to the arrow mark on the graduated scale by means of the lower petcock. (The distance between the arrow mark or initial

- water level and the zero mark corrects for the expansion of the apparatus under the applied pressure of 15 psi and does not represent air.)
- Close the top petcock and apply pressure with the pump until the gauge reads exactly 15 psi or the correct operating pressure.
 - Read and record the subsidence of the water level. Repeat the test on other samples until it is apparent from the results obtained that all the air between the fine aggregate particles is being stirred out.
 - Repeat the above procedure with the sample of coarse aggregate. The sum of the readings obtained for the two samples is the subsidence of the water level due to the air within the aggregate particles, and is the correction to be applied in determining the air content of the concrete. The test can be applied to the sample of fine and coarse aggregate combined, but more difficulty will be experienced in stirring out entrapped air.
- **Determination of air content in concrete: procedure**
- Fill the container with concrete in three equal lifts, rodding each 25 times with 5/8 in. bullet-pointed rod. Strike off the surface. Small variations in the strike-off will have little effect on results.
 - Wipe the contact surfaces clean and clamp the top section of the apparatus firmly to the container.
 - Close the petcock at the bottom of the water glass and open the petcock and funnel valve at the top. Fill the apparatus with water to a level slightly above the arrow mark on the graduated scale. Close the funnel valve and adjust the water level to the arrow mark on the graduated scale by means of the lower petcock.
 - Close the top petcock and apply pressure with the pump until the gauge reads exactly 15 psi or the correct operating pressure.
 - Read the subsidence of the water level and subtract from this value the correction for air held within the pores of the aggregate particles. The resulting value is the percentage of air in the concrete.
 - Release the pressure, opening the top petcock. Release the water by opening the C Clamps. Remove the top and clean the apparatus at once and permit it to dry. It may be necessary to clean the water glass occasionally by removing the nuts at the top and bottom of the water gauge assembly. The threads on the thumb screws and on the funnel valve should be oiled occasionally.
- Corrective air pressure to be used for air contents exceeding limits of scale Correction multiples to be used for the Acme air meter when the air content is so great that a reading is not obtainable using 15 lb pressure.
- Try 10 lb pressure, multiplying reading by 1.25
 - 5 lb = reading \times 2.03
 - 10 lb = reading \times 1.25
 - 15 lbs = reading \times 1.00

4.5. Explanation of computations and data sheet

- Computations: The only computations necessary for this procedure is that involved in determining the air voids in the aggregates, both coarse and fine. Calculate the amount of aggregates that are in the concrete volume equal to the volume of the air meter bowl. This is of course determined by carefully determining the net weight of water required to fill the bowl and then taking that proportional value of the batch to find the weights for the coarse and fine aggregates. Follow the instructions in No. 2 above to obtain G, the air voids in the aggregates. The computed air content of the concrete is obtained from the equation:

$$A_s = A_1 - G$$

Where:

- A_s = Percent entrained air in the concrete specimen
 - A_1 = Apparent percent of air in the concrete specimen since it includes the permeable air voids in the aggregates
 - G = Correction factor in percent for air voids in the aggregates
- Data Sheet: The steps required for the determination are shown below in a convenient data sheet. Batches are generally in m³ or yd³ in accordance with the yield calculation made from ASTM Designation: C 138, in order to compute batch yields to a whole m³ or yd³. A first step, therefore, is to determine the yield of the batch, if this has not already been performed. The batch volume, B, should be to a whole, even m³ or yd³ with the quantities for each component of the mix adjusted to reflect a whole m³ or yd³, F_b and C_b (see equations in Test Procedures). Illustrative example for the data sheet is shown below in table 4-1

Air Content of Fresh Mixed Concrete by the Pressure Method
Weight of measuring bowl and water in kg or lb =
Net weight of measuring bowl in kg or lb =
Volume of measuring bowl in m ³ or yd ³ =
Quantity of F.A. required for test, $F_s = \text{Bowl volume}/\text{batch volume} \times \text{F.A. in batch in kg or lb} =$
Quantity of C.A. required for test, $C_s = \text{Bowl volume}/\text{batch volume} \times \text{C.A. in batch in kg or lb} =$
G =
H1
Hs

Table 4-1: illustrative example for Air content of fresh mixed concrete by the pressure method's data sheet

Chapter Five: Non-destructive tests for Hardened concrete

5.1. General

One of many factors connected with the quality of concrete is its hardness. Efforts to measure the surface hardness of a mass of concrete were first recorded in the 1930s; tests were based on impacting the concrete surface with a specified mass activated by a standard amount of energy. Early methods involved measurements of the size of indentation caused by a steel ball either fixed to a pendulum or spring hammer, or fired from a standardized testing pistol. Later, however, the height of rebound of the mass from the surface was measured. Although it is difficult to justify a theoretical relationship between the measured values from any of these methods and the strength of a concrete, their value lies in the ability to establish empirical relationships between test results and quality of the surface layer. Unfortunately, these are subject to many specific restrictions including concrete and member details, as well as equipment reliability and operator technique.

The rebound principle is more widely accepted: the most popular equipment, the Schmidt Rebound Hammer, has been in use worldwide for many years. Recommendations for the use of the rebound method are given in BS EN 12504-2 and ASTM C805. During this course, both the ultrasonic and the hammer tests will be discussed in details.

Rebound Number of Hardened Concrete by The Swiss Hammer (Developed from: ASTM Designation: C 805)

Introduction

The Swiss engineer Ernst Schmidt first developed a practicable rebound test hammer in the late 1940s, and modern versions are based on this. Figure 5.1 shows the basic features of a typical type N hammer, which weighs less than 2 kg, and has an impact energy of approximately 2.2 Nm. The spring-controlled hammer mass slides on a plunger within a tubular housing. The plunger retracts against a spring when pressed against the concrete surface and this spring is automatically released when fully tensioned, causing the hammer mass to impact against the concrete through the plunger. When the spring-controlled mass rebounds, it takes with it a rider which slides along a scale and is visible through a small window in the side of the casing. The rider can be held in position on the scale by depressing the locking button. The equipment is very simple to use, and may be operated either horizontally or vertically, either upwards or downwards. The plunger is pressed strongly and steadily against the concrete at right angles to its surface, until the spring-loaded mass is triggered from its locked position. After the impact, the scale index is read while the hammer is still in the test position. Alternatively, the locking button may be pressed to enable the reading to be retained, or results can be recorded automatically by an attached paper recorder. The scale reading is known as the rebound number, and is an arbitrary measure since it depends on the energy stored in the given spring and on the

mass used. This version of the equipment is most commonly used, and is most suitable for concretes in the 20–60N/mm² strength range. For low strength, concrete in the 5–25N/mm² strength range it is recommended that a pendulum type rebound hammer is used which has an enlarged hammer head (Type P).

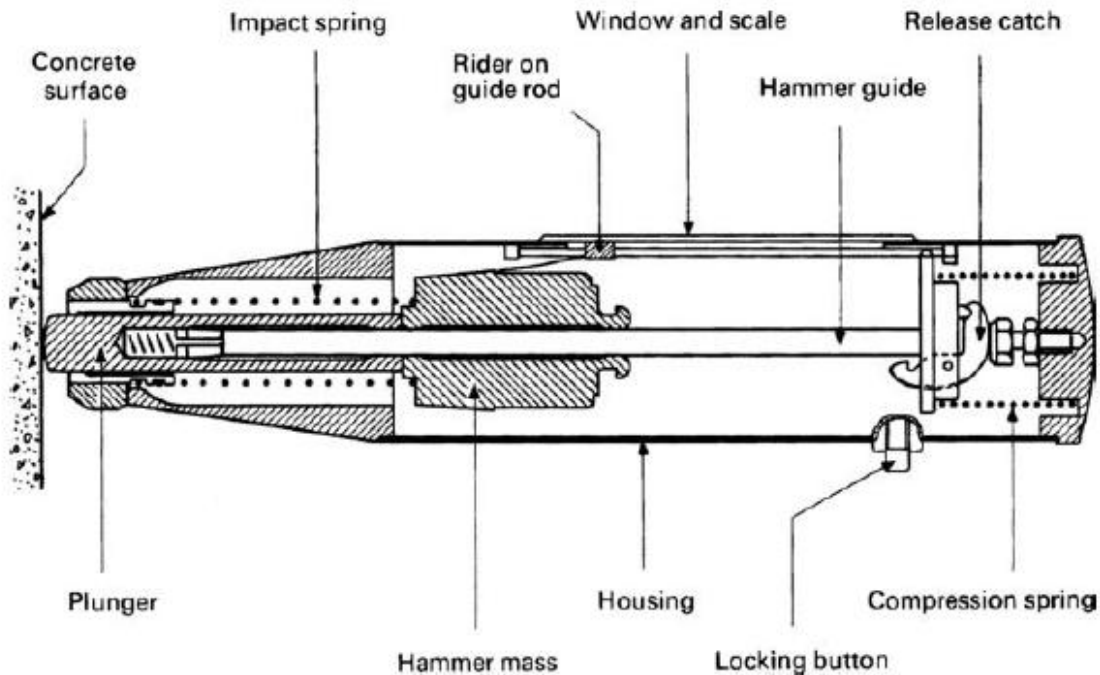

Figure 5-1: Typical rebound hammer.

The test is based on the principle that the rebound of an elastic mass depends on the hardness of the surface upon which it impinges, and in this case will provide information about a surface layer of the concrete defined as no more than 30mm deep. The results give a measure of the relative hardness of this zone, and this cannot be directly related to any other property of the concrete. Energy is lost on impact due to localized crushing of the concrete and internal friction within the body of the concrete, and it is the latter, which is a function of the elastic properties of the concrete constituents, that makes theoretical evaluation of test results extremely difficult. Many factors influence results but all must be considered if rebound number is to be empirically related to strength.

As previously mentioned, the results obtained using the rebound hammer are significantly influenced by all many factors. Since each of these factors may affect the readings obtained, any attempts to compare or estimate concrete strength will be valid only if they are all standardized for the concrete under test and for the correlation specimens. These influences have different magnitudes. Hammer orientation will also influence measured values although correction factors can be used to allow for this effect.

These factors are as following:

- Mix characteristics
 - (i) Cement type: Variations in fineness of Portland cement are unlikely to be significant – their influence on strength correlation is less than 10%. Super-sulfated cement, however, can be expected to yield strengths 50% lower than suggested by a Portland cement correlation, whereas high alumina cement concrete may be up to 100% stronger.
 - (ii) Cement content: Changes in cement content do not result in corresponding changes in surface hardness. The combined influence of strength, workability and aggregate/cement proportions leads to a reduction of hardness relative to strength as the cement content increases. The error in estimated strength, however, is unlikely to exceed 10% from this cause for most mixes
 - (iii) Coarse aggregate type: The influence of aggregate type and proportions can be considerable, since strength is governed by both paste and aggregate characteristics. The rebound number will be influenced more by the hardened paste. For example, crushed limestone may yield a rebound number significantly lower than for a gravel concrete of similar strength which may typically be equivalent to a strength difference of 6–7N/mm². A particular aggregate type may also yield different rebound number/strength correlations depending on the source and nature, and Figure 5-2 compares typical curves for hard and soft gravels. These have measured hardness expressed in terms of the Mohs' number of 7 and 3 respectively.

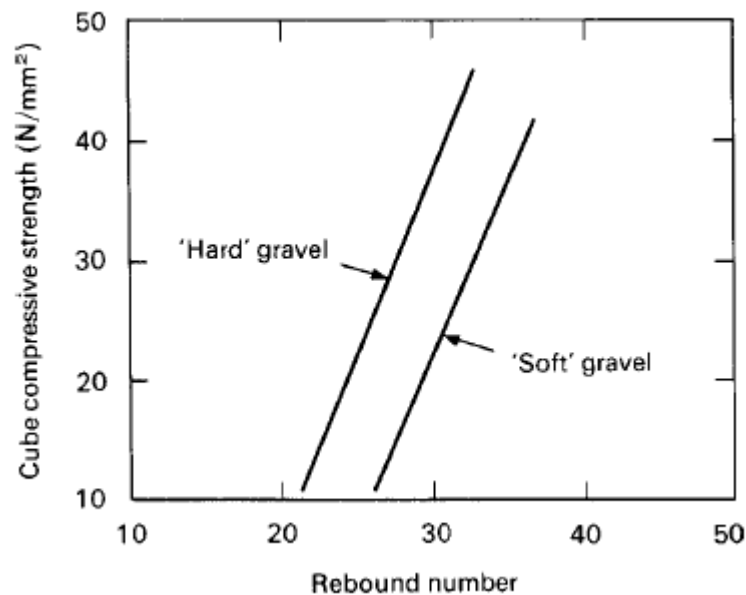

Figure 5-2: Comparison of hard and soft gravels – vertical hammer.

- Member characteristics

(i) Mass: The effective mass of the concrete specimen or member under test must be sufficiently large to prevent vibration or movement caused by the hammer impact. Any such movement will result in a reduced rebound number. For some structural members the slenderness or mass may be such that this criterion is not fully satisfied, and in such cases absolute strength prediction may be difficult. BS EN 12504-2 requires that a member is at least 100mm thick and fixed within a structure. Strength comparisons between or within individual members must also take account of this factor. The mass of correlation specimens may be effectively increased by clamping them firmly in a heavy testing machine.

(ii) Compaction: Since a smooth, well-compacted surface is required for the test, variations of strength due to internal compaction differences cannot be detected with any reliability. All calibrations must assume full compaction.

(iii) Surface type: Hardness methods are not suitable for open-textured or exposed aggregate surfaces. Trowelled or floated surfaces may be harder than moulded surfaces, and will certainly be more irregular. Although they may be smoothed by grinding, this is laborious and it is best to avoid trowelled surfaces in view of the likely overestimation of strength from hardness readings. The absorption and smoothness of the mould surface will also have a considerable effect. Calibration specimens will normally be cast in steel moulds which are smooth and non-absorbent, but more absorbent shuttering may well produce a harder surface, and hence internal strength may be overestimated. Although moulded surfaces are preferred for on-site testing, care must be taken to ensure that strength correlations are based on similar surfaces, since considerable errors can result from this cause.

(iv) Age, rate of hardening and curing type: The relationship between hardness and strength has been shown to vary as a function of time, and variations in initial rate of hardening, subsequent curing and exposure conditions will further influence this relationship. Where heat treatment or some other form of accelerated curing has been used, a specific calibration will be necessary. The moisture state may also be influenced by the method of curing. For practical purposes the influence of time may be regarded as unimportant up to the age of three months, but for older concretes it may be possible to develop reduction factors which take account of the concrete's history.

(v) Surface carbonation: Concrete exposed to the atmosphere will normally form a hard carbonated skin, whose thickness will depend upon the exposure conditions and age. It may exceed 20mm for old concrete although it is unlikely to be significant at ages of less than three months. Examination of gravel concrete specimens which had been exposed to an outdoor 'city-centre' atmosphere for six months showed a carbonated depth of only 4 mm. This was not sufficient to influence the rebound number/strength relationship in comparison with similar specimens stored in a laboratory atmosphere although for these specimens no

measurable skin was detected. In extreme cases, however, it is known that the overestimate of strength from this cause may be up to 50%, and is thus of great importance. When significant carbonation is known to exist, the surface layer ceases to be representative of the concrete within an element.

(vi) Moisture condition: The hardness of a concrete surface is lower when wet than when dry, and the rebound/strength relationship will be influenced accordingly. This effect is illustrated by Figure 5-3, based on early work by the US army, from which it will be seen that a wet surface test may lead to an underestimate of strength of up to 20%. Field tests and strength calibrations should normally be based on dry surface conditions, but the effect of internal moisture on the strength of control specimens must not be overlooked.

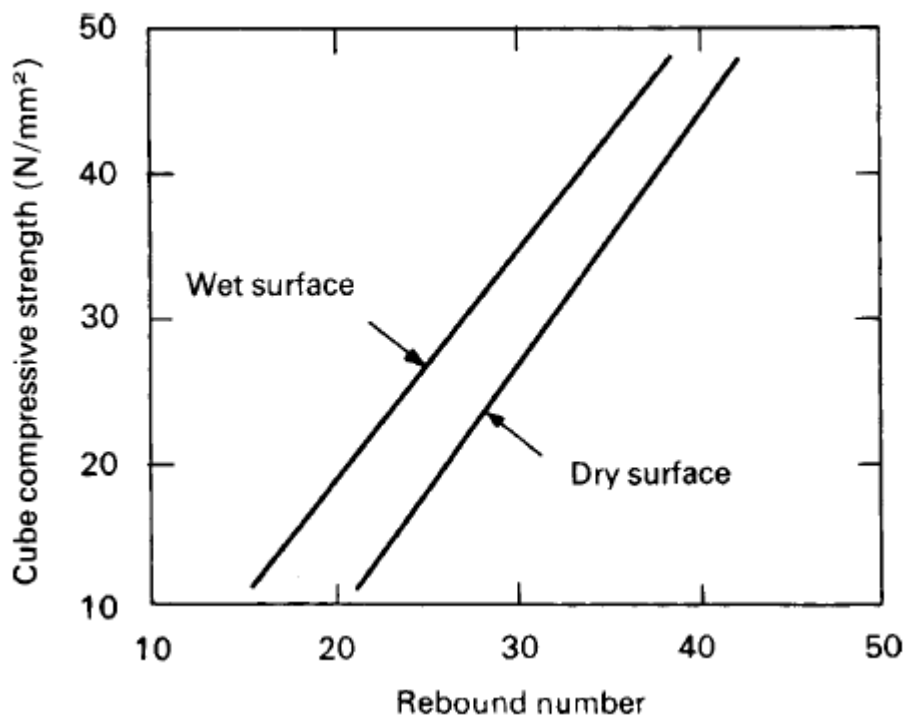

Figure 5-3: Influence of surface moisture condition – horizontal hammer

(vii) Stress state and temperature. Both these factors may influence hardness readings, although in normal practical situations this is likely to be small in comparison with the many other variables. Particular attention should, however, be paid to the functioning of the test hammer if it is to be used under extremes of temperature, noting the limits of 10 to 35C in BS EN 12504-2.

▪ Purpose

The purpose is to measure the rebound of a spring-loaded hardened steel I plunger after it has struck a smooth, solid, concrete surface. Only empirical relationships can be obtained between

rebound hardness and the strength of the concrete. Unlike the standard test for the concrete strength, ASTM Designation: C 39, this is a nondestructive test. In 1948 a Swiss engineer, Dr. Ernst Schmidt, developed the first generally accepted impact hammer. It is sometimes referred to as the “Swiss hammer.”

Materials and equipment

- a) Spring-loaded steel rebound hammer which when released strikes a steel 1 plunger in contact with the concrete surface. The rebound distance of the steel hammer from the steel plunger is measured on a linear scale attached to the frame of the hammer; note the detail of the hammer and its method of use in Figures 5-1 and 5-4
- b) Medium-grain, textured, silicon carbide abrasive stone for grinding smooth any loose mortar or other imperfections on the surface of the concrete to be tested
- c) High carbon tool steel test anvil, with dimensions of 15 cm diameter (6 in.) by 15 cm (6 in.) in height, with a fixture to center the rebound hammer over the impact area (hardened to a Rockwell 65-67 C) and designed to keep the device perpendicular to the concrete surface, the results of the test hammer should be verified twice a year by use of the test anvil (Figure 5-5)

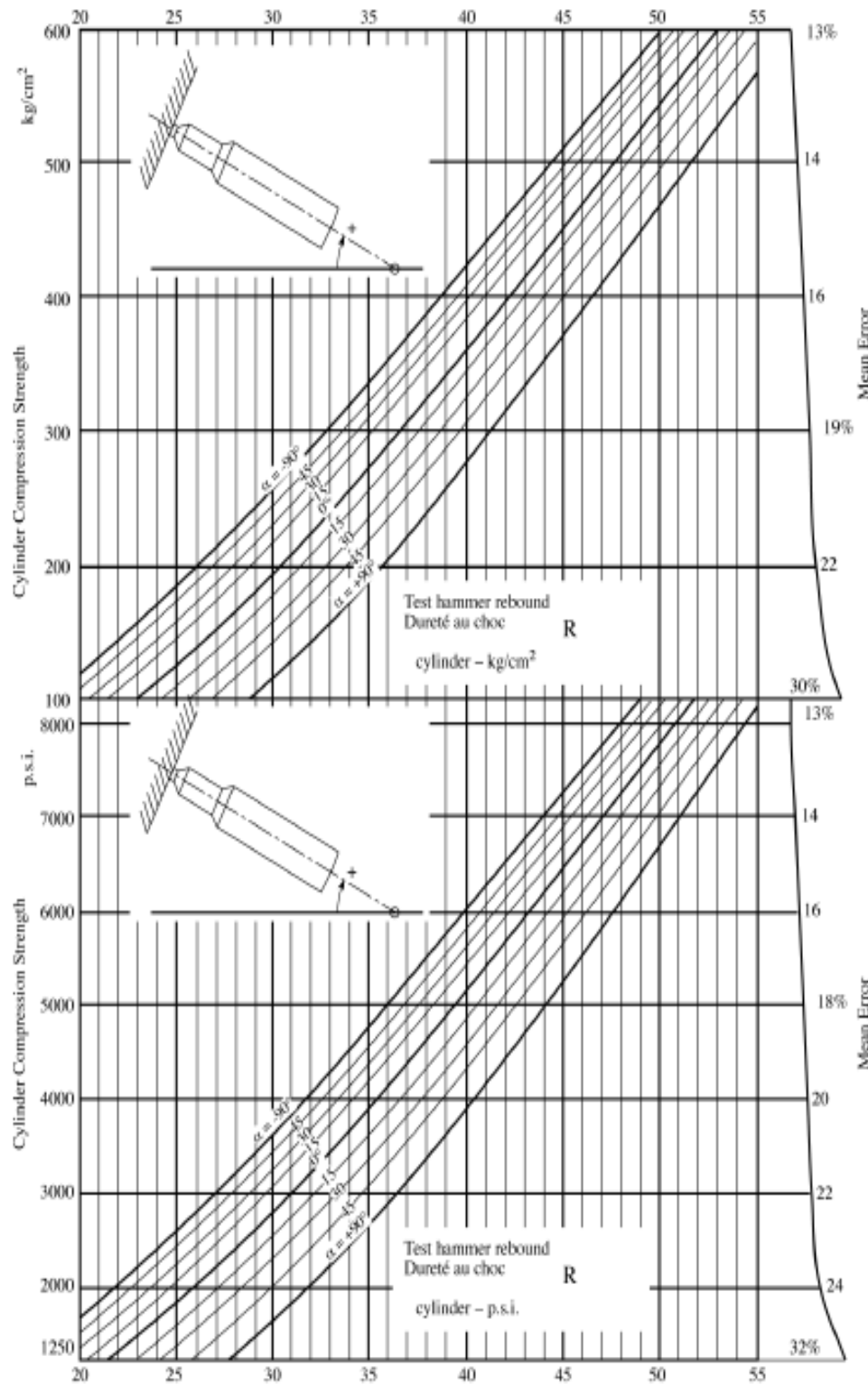

Figure 5-4: Typical impact hammer calibration curves.

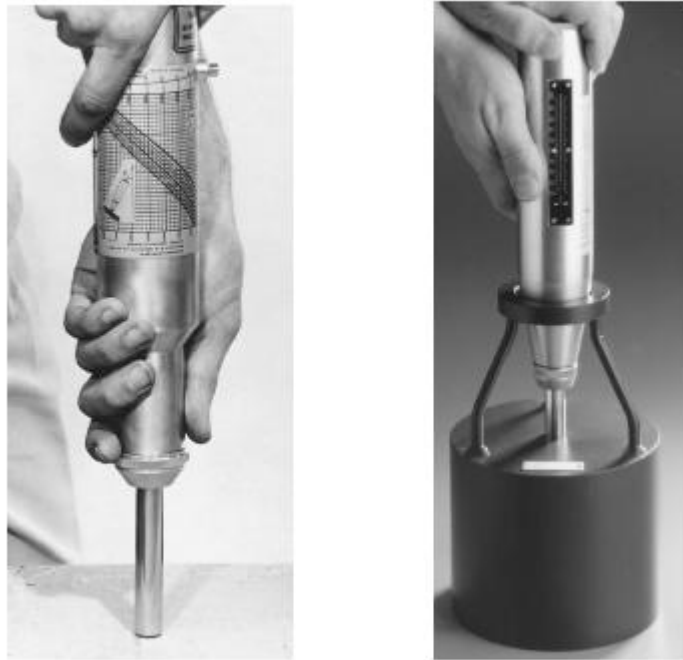

Figure 5-5: (left) the impact hammer in operation in the vertical position, directed downward, and (right) the calibration anvil for the impact hammer.

Test procedure

1. The test hammer should be held perpendicular to the concrete surface. The plunger should be depressed by applying a gradual increase in pressure until it impacts. A reading is then taken from the scale on the side of the test hammer, while holding it firmly against the concrete. A button is provided to lock the pointer on the scale after impact in the event that it is not convenient to take the reading while holding the test hammer against the concrete. The latter case is particularly true when the hammer is held in an overhead position. Estimate the rebound on the scale to the nearest whole number.
2. Conversion graphs or tables are provided with the instrument to indicate a measure of compressive strength with the reading obtained from the test hammer scale. A typical set of such graphs is shown in Figure 5-4. Each instrument will come with its own set of graphs or tables prepared by the manufacturer.
3. Take 10 readings from each test area, with all the readings separated by at least 2.5 cm (1 in.). Disregard any reading where an impression is made on the surface of the concrete after the hammer impact, whether through crushing or breaking the surface or for any other visible surface imperfection.

4. If the rebound number on the anvil deviates from the nominal value shown on the manufacturer's instructions, the following formula applies:

$$R = r/n \text{ (specified value on the anvil/Ra)}$$

Where n = number of individual measurements, r , on the concrete, R_a = rebound number of the test hammer on the anvil, and R = number measured on the concrete.

▪ **Explanation of computations and data sheet**

1. Computations: Take the average of the 10-rebound readings. Discard those readings that differ from this average by 6 or more units. Compute the new average and determine the resultant compressive concrete strength. However, if more than two readings from the original set of 10, differ by more than 6, the entire set should be discarded and 10 new rebound readings taken at new locations within the test area.

2. Data Sheet: Ten readings are shown on the following data sheet. The average of the 10 was found to be 49. However, two of the readings at 56 and 71 are 6 or more above the average of 49. Therefore, they are discarded and a new average for the remaining 8 values were computed to be 46. From the psi graph (Figure 5-4), the compressive strength of the concrete was found to be 5400 psi for a vertically held hammer in a downward position. If a third value was 6 or more above the average of 49, the entire set would have been discarded. A blank data sheet is shown below and two additional ones are included in Appendix. Again, it must be emphasized that no theoretical relationship exists between the plunger rebound and the concrete strength. The rebound hammer should only be used in checking concrete uniformity and in comparing one concrete with another, not for any measure of absolute concrete strength.

Illustrative Example (ASTM C 805)

<i>Test Number</i>	<i>Readings</i>	<i>Remarks</i>
1	45	Test on 28-day concrete cylindrical test specimen, 6 × 12 in. height. Hammer held in a vertical position downward.
2	51	
3	37	
4	56	
5	39	
6	71	
7	47	
8	44	
9	50	
10	53	
Average of 10 readings = 49		
Reading nos. discarded, 4 and 6		
New average = 46		
Concrete compressive strength, kPa or psi = 5400 psi		

Table 5-1: Illustrative example for ten readings taken using the hammer

Test number	Readings	Remarks
1		
2		
3		
4		
5		
6		
7		
8		
9		
10		
Average of 10 readings =		
Reading nos. discarded,=		
New average =		
Concrete compressive strength, kPa or psi =		

Table 5-2: Example for the data sheet

5.1.1. The Ultrasonic pulse velocity method (Developed from BS EN 12504-4 and ASTM C597).

▪ Background

The first reports of the measurement of the velocity of mechanically generated pulses through concrete appeared in the USA in the mid-1940s. It was found that the velocity depended primarily upon the elastic properties of the material and was almost independent of geometry. The potential value of this approach was apparent, but measurement problems were considerable, and led to the development in France, a few years later, of repetitive mechanical pulse equipment. At about the same time, work was undertaken in Canada and the United Kingdom using electro-acoustic transducers, which were found to offer greater control on the type and frequency of pulses generated. This form of testing has been developed into the modern ultrasonic method, employing pulses in the frequency range of 20–150 kHz, generated and recorded by electronic circuits. Ultrasonic testing of metals commonly uses a reflective pulse technique with much higher frequencies, but this cannot readily be applied to concrete because of the high scattering which occurs at matrix/aggregate interfaces and microcracks. Concrete testing is thus at present based largely on pulse velocity measurements using through-transmission techniques. The method has become widely accepted around the world, and commercially produced robust lightweight equipment suitable for site as well as laboratory use is readily available.

It was found that UPV methods, where the amplitude of the signal was studied, could be used to estimate microcrack growth in concrete and hence to study mechanical damage, whilst Pavlakovic et al. have used a guided wave technique to study damage in post-tensioned tendons in bridges. Krause et al. have studied ultrasonic imaging with an array system to examine defects behind dense steel reinforcement, including cover to pipe ducts and ungrouted tendon ducts. Koehler has further examined the use of specialized Synthetic Aperture Focussing Techniques (SAFT) to provide 3D visualization of defects in concrete structures, such as gravel pockets, and to locate tendon ducts. Krause and Wiggerhauser also successfully used ultrasonic 2D and 3D methods to establish the position of tendon ducts in a bridge deck, and Popovics has recently reviewed some of these techniques together with tomography. Andrews has suggested that there is much scope for new applications with the development of improved fidelity transducers and computer interpretation. Study of pulse attenuation characteristics has been shown by the authors to provide useful data relating to deterioration of concrete due to alkali–silica reaction although there are practical problems of achieving consistent coupling on site. Hillger and Kroggel have both described the development of pulse-echo techniques to permit detection of defects and cracks from tests on one surface as well as the use of a vacuum coupling system, and the application of signal processing techniques to yield information about internal defects and features is the subject of current research as noted above. Another interesting development, described by Sack and

Olson, involves the use of rolling transmitter and receiver scanners, which do not need any coupling medium, with a computer data acquisition system that permits straight line scans of up to 9m to be made within a timescale of less than 30 seconds.

Although it is likely that many of these developments will expand into commercial use in the future, the remainder of this chapter will concentrate upon conventional pulse velocity techniques. If the method is properly used by an experienced operator, a considerable amount of information about the interior of a concrete member can be obtained. However, since the range of pulse velocities relating to practical concrete qualities is relatively small (3.5–4.8 km/s), great care is necessary, especially for site usage. Furthermore, since it is the elastic properties of the concrete which affect pulse velocity, it is often necessary to consider in detail the relationship between elastic modulus and strength when interpreting results. Recommendations for the use of this method are given in BS EN 12504-4 and also in ASTM C597.

- **Purpose**

The purpose is to measure the time required for a pulse to cross a length of cubical, cylindrical specimens and beam in order to make an expectation on their material or structural behavior. Unlike the standard test for the concrete strength, ASTM Designation: C 39, this is a nondestructive test.

- **Theory**

Three types of waves are generated by an impulse applied to a solid mass. Surface waves having an elliptical particle displacement are the slowest, whereas shear or transverse waves with particle displacement at right angles to the direction of travel are faster. Longitudinal waves with particle displacement in the direction of travel (sometimes known as compression waves) are the most important since these are the fastest and generally provide more useful information. Electro-acoustical transducers primarily produce waves of this type; other types generally cause little interference because of their lower speed. The wave velocity depends upon the elastic properties and mass of the medium, and hence if the mass and velocity of wave propagation are known it is possible to assess the elastic properties. For an infinite, homogeneous, isotropic elastic medium, the compression wave velocity is given by:

$$V = \sqrt{\frac{K \cdot E_d}{\rho}} \text{ (km/s)}$$

where E_d = Dynamic modulus of elasticity (N/mm²)

ρ = density (kg/m³)

$$K = \frac{(1-\nu)}{(1+\nu)(1-2\nu)}$$

and ν = dynamic Poisson's ratio

Operation is relatively straightforward but requires great care if reliable results are to be obtained. One essential is good acoustical coupling between the concrete surface and the face of the transducer, and this is provided by a medium such as petroleum jelly, liquid soap or grease. Air pockets must be eliminated, and it is important that only a thin separating layer exists – any surplus must be squeezed out. A light medium, such as petroleum jelly or liquid soap, has been found to be the best for smooth surfaces, but a thicker grease is recommended for rougher surfaces which have not been cast against smooth shutters. If the surface is very rough or uneven, grinding or preparation with plaster of Paris or quick-setting mortar may be necessary to provide a smooth surface for transducer application. It is also important that readings are repeated by complete removal and re-application of transducers to obtain a minimum value for the transit time. Although the measuring equipment is claimed to be accurate to ± 0.1 microseconds, if a transit time accuracy of $\pm 1\%$ is to be achieved it may typically be necessary to obtain a reading to $\pm 0.7s$ over a 300mm path length. This can only be achieved with careful attention to measurement technique, and any dubious readings should be repeated as necessary, with special attention to the elimination of any other source of vibration, however slight, during the test. The path length must also be measured to an accuracy of $\pm 1\%$. This should present little difficulty with paths over about 500 mm, but for shorter paths it is recommended that calipers be used.

a) Transducer arrangement

There are three basic ways in which the transducers may be arranged, as shown in Figure 5-6. These are:

- (i) Opposite faces (direct transmission)
- (ii) Adjacent faces (semi-direct transmission)
- (iii) Same face (indirect transmission).

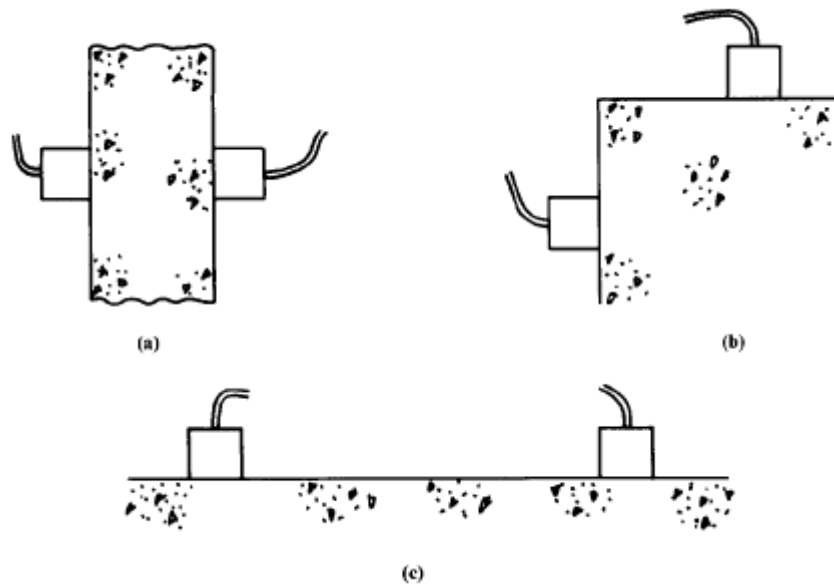

Figure 5-6: Types of reading: (a) Direct; (b) semi-direct; (c) indirect.

b) Practical factors influencing measured results

i) Temperature

The operating temperature ranges to be expected in temperate climates are unlikely to have an important influence on pulse velocities, but if extreme temperatures are encountered, their effect can be estimated from Figure 5-7.

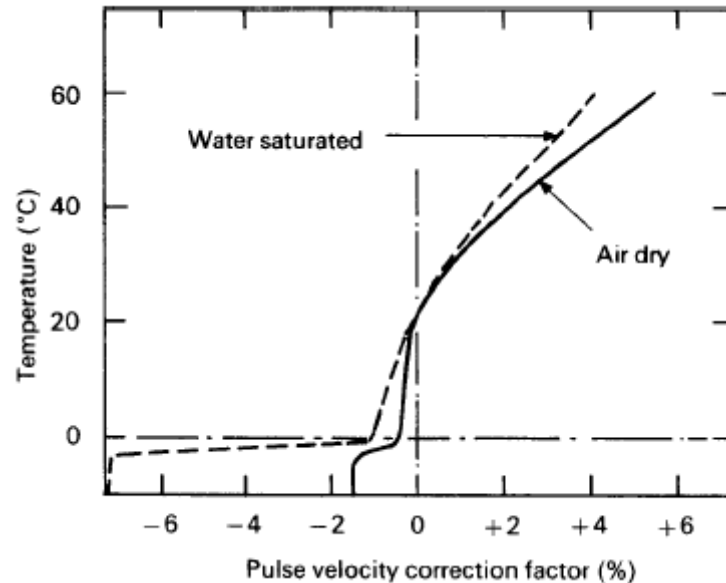

Figure 5-7: Effect of temperature

ii) Stress history

It has been generally accepted that the pulse velocity of laboratory cubes is not significantly affected until a stress of approximately 50% of the crushing strength is reached. It has been clearly shown that, under service conditions in which stresses would not normally exceed one-third cube strength, the influence of compressive stress on pulse velocity is insignificant, and that pulse velocities for prestressed concrete members may be used with confidence. Only if a member has been seriously overstressed will pulse velocities be affected. Tensile stresses have been found to have a similarly insignificant effect, but potentially cracked regions should be treated with caution, even when measurements are parallel to cracks, since these may introduce path widths below acceptable limits.

iii) Path Length

Pulse velocities are not generally influenced by path length provided that this is not excessively small, in which case the heterogeneous nature of the concrete may become important. Physical limitations of the time-measuring equipment may also introduce errors where short path lengths are involved. These effects are shown in Figure 5-8, in which a laboratory specimen has been incrementally reduced in length by sawing. BS EN 12504-4 recommends minimum path lengths of 100 and 150mm for concrete with maximum aggregate sizes of 20 and 40mm respectively. For unmodelled surfaces, a minimum length of 150mm should be

adopted for direct, or 400mm for indirect, readings. There is evidence that the measured velocity will decrease with increasing path length, and a typical reduction of 5% for a path length increase from approximately 3 to 6m is reported. This is because attenuation of the higher frequency pulse components results in a less clearly defined pulse onset. The characteristics of the measuring equipment are therefore an important factor. If there is any doubt about this, it is recommended that some verification tests be performed, although in most practical situations path length is unlikely to present a serious problem.

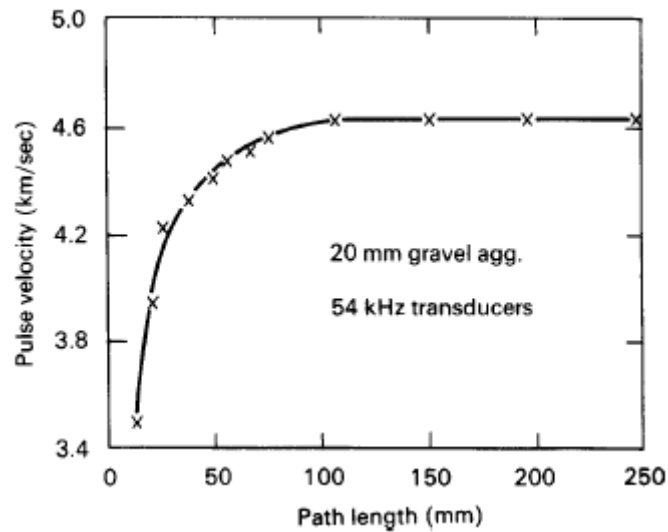

Figure 5-8: Effect of short path length

iv) Moisture conditions

The pulse velocity through saturated concrete may be up to 5% higher than through the same concrete in a dry condition, although the influence will be less for high-strength than for low-strength concretes. The effect of moisture condition on both pulse velocity and concrete strength is thus a further factor contributing to calibration difficulties, since the moisture content of concrete will generally decrease with age. A moist specimen shows a higher pulse velocity, but lower measured strength than a comparable dry specimen, so that drying out results in a decrease in measured pulse velocity relative to strength. The effect is well illustrated by the results in Figure 5-9 which relate to otherwise identical laboratory specimens, and demonstrates the need to correlate test cube moisture and structure moisture during strength calibration. It is thus apparent that strength correlation curves are of limited value for application to in-place concrete unless based on the appropriate moisture conditions.

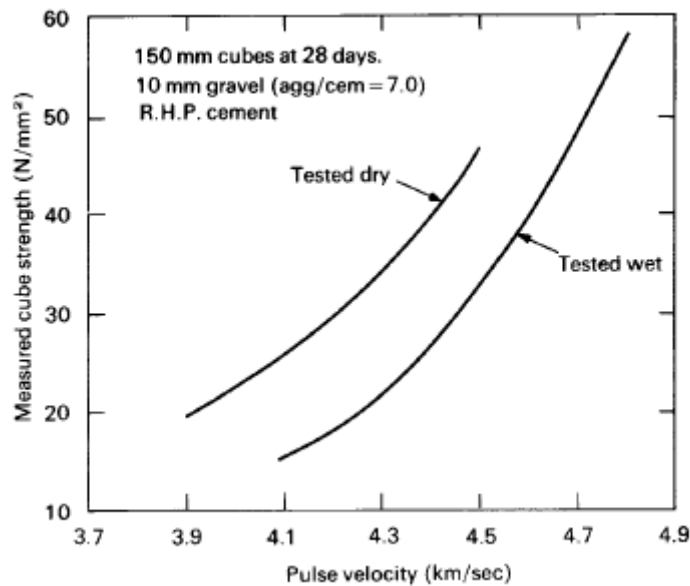

Figure 5-9: Effect of moisture conditions

v) Reinforcement

Reinforcement, if present, should be avoided if at all possible, since considerable uncertainty is introduced by the higher velocity of pulses in steel coupled with possible compaction shortcomings in heavily reinforced regions. There will, however, often be circumstances in which it is impossible to avoid reinforcing steel close to the pulse path, and corrections to the measured value will then be necessary. Corrections are not easy to establish, and the influence of the steel may dominate over the properties of the concrete so that confidence in estimated concrete pulse velocities will be reduced.

c) Applications

The applications of pulse velocity measurements are so wide-ranging that it would be impossible to list or describe them all. The principal applications are outlined below – the method can be used both in the laboratory and on site with equal success.

i) Measurement of concrete uniformity

This is probably the most valuable and reliable application of the method in the field. There are many published reports of the use of ultrasonic pulse velocity surveys to examine the strength variations within members. The statistical analysis of results, coupled with the production of pulse velocity contours for a structural member, may often also yield valuable information concerning variability of both material and construction standards. Readings should be taken

on a regular grid over the member. A spacing of 1m may be suitable for large uniform areas, but this should be reduced for small or variable units.

ii) Detection of cracking and honeycombing

A valuable application of the ultrasonic pulse velocity techniques which does not require detailed correlation of pulse velocity with any other property of the material is in the detection of honeycombing and cracking. Since the pulse cannot travel through air, the presence of a crack or void on the path will increase the path length (as it goes around the flaw) and increase attenuation so that a longer transit time will be recorded. The apparent pulse velocity thus obtained will be lower than for the sound material. Since compression waves will travel through water, it follows that this philosophy will apply only to cracks or voids which are not water-filled. It has been examined this in detail and concluded that although water filled cracks cannot be detected, water-filled voids will show a lower velocity than the surrounding concrete. Voids containing honeycombed concrete of low pulse velocity will behave similarly. A given void is more difficult to detect as the path length increases, but the absolute minimum size of detectable defect will be set by the diameter of the transducer used.

iii) Strength estimation

Unless a suitable correlation curve can be obtained, it is virtually impossible to predict the absolute strength of a body of in-situ concrete by pulse velocity measurements. Although it is possible to obtain reasonable correlations with both compressive and flexural strength in the laboratory, enabling the strength of comparable specimens to be estimated to $\pm 10\%$, the problems of relating these to in-situ concrete are considerable.

iv) Other applications like the assessment of concrete deterioration and Measurement of layer thickness.

▪ **Equipment**

b) The test equipment must provide a means of generating a pulse, transmitting this to the concrete, receiving and amplifying the pulse and measuring and displaying the time taken. Transducers with natural frequencies between 20 and 150 kHz are the most suitable for use with concrete, and these may be of any type.

c) Lubricating material

▪ **Procedure**

- a) First, the surface of hardened concrete which will be tested should be lubricated with the lubricating material to eliminate any effects from the voids or cracks on the surface and also to remove the effects caused from the bad finish.
- b) Then, the transducers of the device will be placed on the surface of the concrete by using one of the three methods mentioned before. Also the distance between the transducers should be measured.
- c) A button in the device is pressed in, and the reading for the time is taken in microseconds from the monitor in the device.
- d) After that, the velocity of the waves will be calculated by using the following equation.

$$\text{Velocity} = \text{distance} / \text{time}$$
- e) After the velocity has been calculated, using the chart given from the lab technician, approximation strength for the specimens will be finding.

▪ **Data Sheet**

A blank data sheet is shown below and two additional ones are included in Appendix.

Type of specimen	Arrangement of transducers	Distance (cm)	Time (μs)	Velocity (Km/sec)	Strength (Mpa)

Table 5-4: Example for the data sheet to be used

Chapter Six: Core Test

Developed from BS EN 12504-1 and ASTM C42 and ACI 318

6.1. Purpose of the experiment

The aims of this experiment are to examine and carry out compression test for a core cuts from hardened concrete beam and to perform a visual inspection of the interior regions of the member. In this experiment, other physical properties like density and water absorption can be measured.

6.2. Theory

The examination and compression testing of cores cut from hardened concrete is a well-established method, enabling visual inspection of the interior regions of a member to be coupled with strength estimation. Other physical properties which can be measured include density, water absorption, indirect tensile strength and movement characteristics including expansion due to alkali–aggregate reactions. Cores are also frequently used as samples for chemical analysis following strength testing.

Core location will be governed primarily by the basic purpose of the testing, bearing in mind the likely strength distributions within the member, related to the expected stress distributions. Where serviceability assessment is the principal aim, tests should normally be taken at points of likely minimum strength, for example from the top surface at near midspan for simple beams and slabs, or from any face near the top of lifts for columns or walls. If the member is slender, however, and core cutting may impair future performance, cores should be taken at the nearest non-critical locations. Aesthetic considerations concerning the appearance after coring may also sometimes influence the choice of locations. Alternatively, areas of suspect concrete may have been located by other methods.

Where the core is to be used for compression testing, British and American Standards require that the diameter is at least three times the nominal maximum aggregate size. In many countries, including the UK, a minimum diameter of 100mm is used, with 150mm preferred, although in Australia 75mm is considered to be generally acceptable. In general, the accuracy decreases as the ratio of aggregate size to core diameter increases and 100mm diameter cores should not be used if the maximum aggregate size exceeds 25 mm, and this should preferably be less than 20mm for 75mm cores. The choice of core diameter will also be influenced by the length of specimen which is possible. It is generally accepted that cores for compression testing should have a length/diameter ratio of between 1.0 and 2.0, but opinions vary concerning the optimum value. BS EN 12504-1 (135) recommends a ratio of 2.0 if results are to be related to cylinder strengths or 1.0 for cube strengths.

The Concrete Society suggest that cores should be kept as short as possible ($l/d = 1.0 \rightarrow 1.2$) for reasons of drilling costs, damage, variability along length, and geometric influences on testing. The number of cores required will depend upon the reasons for testing and the volume of concrete involved. The number of cores must be sufficient to be representative of the concrete under examination as well as provide a strength estimate of acceptable accuracy. ACI 318 requires that at least three cores are always used.

There are many factors influencing measured core compressive strength. These factors may be divided into two basic categories according to whether they are related to concrete characteristics or testing variables.

- **Concrete characteristics**

The moisture condition of the core will influence the measured strength – a saturated specimen has a value 10–15% lower than a comparable dry specimen. It is thus very important that the relative moisture conditions of core and in-situ concrete are taken into account in determining actual in-situ concrete strengths. If the core is tested while saturated, comparison with standard control specimens which are also tested saturated will be more straightforward but there is evidence that moisture gradients within a core specimen will also tend to influence measured strength. This introduces additional uncertainties when procedures involving only a few days of either soaking or air drying are used since the effects of this conditioning are likely to penetrate only a small distance below the surface. The curing regime, and hence strength development, of a core and of the parent concrete will be different from the time of cutting. This effect is very difficult to assess, and in mature concrete may be ignored, but should be considered for concrete of less than 28 days old.

Voids in the core will reduce the measured strength, and this effect can be allowed for by measurement of the excess voidage when comparing core results with standard control specimens from the point of view of material specification compliance. Figure 6.1 shows the influence of this effect. Under normal circumstances an excess voidage of 0.5–1.0% would be expected. Higher values imply increasingly poorer compaction and should certainly be less than 2.5%.

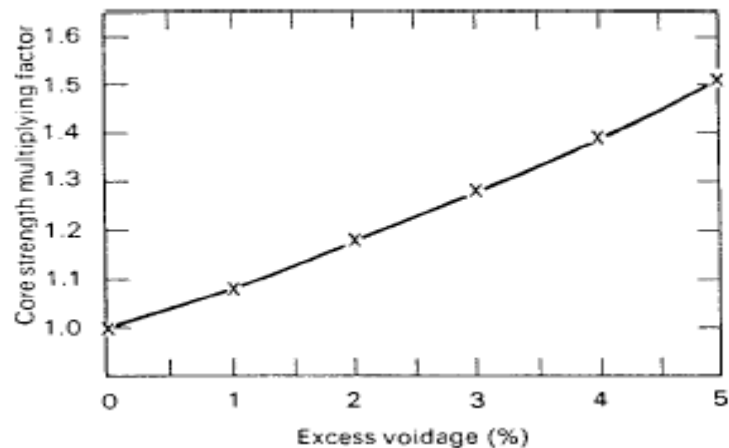

Figure 6-1: Excess voidage corrections

▪ **Testing variables**

These are numerous, and in many cases will have a significant influence upon measured strength. The most significant factors are outlined below.

- .1. Length/diameter ratio of core. As the ratio increases, the measured strength will decrease due to the effect of specimen shape on stress distributions whilst under test. Since the standard cylinder used in many parts of the world has a length/diameter ratio of 2.0, this is normally regarded as the datum for computation of results, and the relationship between this and a standard cube is established. It is claimed that correction factors to an equivalent length/diameter ratio of 2.0 will move towards 1.0 for soaked cores and as concrete strength increases. This issue is widely recognized to be subject to many uncertainties, but the average values shown in Figure 6-2 are based on the Concrete Society recommendations. These differ from ASTM (136) suggestions which recognize, but do not allow for, strength effects and are also limited to cylinder strengths in the range 13–41N/mm².

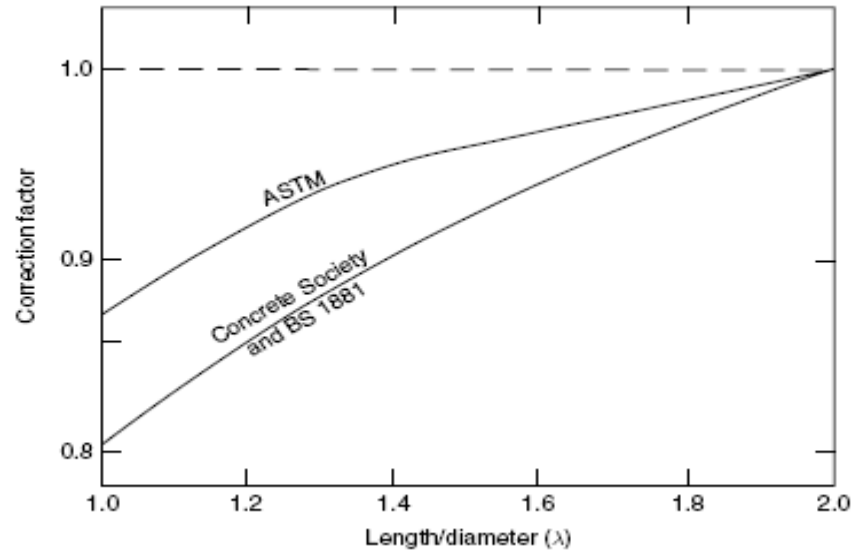

Figure 6-2: Length/diameter ratio influence

- .2. Diameter of core. The diameter of core may influence the measured strength and variability. Measured concrete strength will generally decrease as the specimen size increases; for sizes above 100mm this effect will be small, but for smaller sizes this effect may become significant. However, as the diameter decreases, the ratio of cut surface area to volume increases, and hence the possibility of strength reduction due to cutting damage will increase. It is generally accepted that a minimum diameter/maximum aggregate size ratio of 3 is required to make test variability acceptable.
- .3. Direction of drilling. As a result of layering effects, the measured strength of specimen drilled vertically relative to the direction of casting is likely to be greater than that for a horizontally drilled specimen from the same concrete. Published data on this effect are variable, but an average difference of 8% is suggested although there is evidence that this effect may be influenced by concrete workability and is not found with lightweight aggregate concretes. Whereas standard cylinders are tested vertically, cubes will normally be tested at right angles to the plane of casting and hence can be related directly to horizontally drilled cores.
- .4. Method of capping. Provided that the materials recommended in the procedure have been used, their strength is greater than that of the core, and the caps are sound, flat, perpendicular to the axis of the core and not excessively thick, the influence of capping will be of no practical significance.
- .5. Reinforcement. Published research results indicate that the reduction in measured strength due to reinforcement may be less than 10%, but the variables of size, location and bond make it virtually impossible to allow accurately for this effect.

Reinforcement must therefore be avoided wherever possible, but in cases where it is present the measured core strength may be corrected but treated with caution. Recent developments in coring technology in Germany have resulted in a drilling machine with an automatic detection and stop facility before reinforcement is cut. Experienced drillers will also look at the colour of the cutting fluid. A sudden darkening is often an indication of reinforcement.

It is suggested that for a core containing a bar perpendicular to the axis of the core the following correction factor may be applied to the measured core strength although it is sometimes recommended that the core should be disregarded if the correction is greater than 10%:

$$\text{Corrected strength} = \text{measured strength} \times \left[1.0 + 1.5 \left(\frac{\phi_t}{\phi_c} \cdot \frac{b}{l}\right)\right]$$

Where ϕ_t = bar diameter

ϕ_c = core diameter

b = distance of bar axis from nearer end of core

l = core length (uncapped)

Multiple bars within a core can similarly be allowed for by the expression

$$\text{Corrected strength} = \text{measured strength} \times \left[1.0 + 1.5 \left(\frac{\sum \phi_t \cdot b}{\phi_c \cdot l}\right)\right]$$

If the spacing of two bars is less than the diameter of the larger bar, only the bar with the higher value of (ϕ_t , b) should be considered.

- Estimation of an equivalent cube strength corresponding to a particular core result must initially account for two main factors. These are
 - .1. The effect of the length/diameter ratio, which requires a correction factor, illustrated by Figure 6.2, to be applied to convert the core strength to an equivalent standard cylinder strength.
 - .2. Conversion to an equivalent cube strength using an appropriate relationship between the strength of cylinders and cubes.

Corrections for the length/diameter ratio of the core have been discussed above. Subsequent conversion to a cube strength is usually based on the generally accepted average relationship that cube strength = 1.25 cylinder strength (for $l/d = 2.0$). Within the range of 20–50N/mm² cylinder strengths this produces values within 10% of those given by the average factor 1.25, but the discrepancies increase for lower- and higher-strength concretes. Such discrepancies will, however, be partially offset for cores with l/d close to 1.0 by the errors resulting from the use of (l/d) ratio correction factors which are not strength-related. Particular care will be needed to take account of this issue when dealing with cores of high-strength concrete, which is increasingly being used worldwide.

The Concrete Society recommends a procedure incorporating the correction factors of Figure 6-2, coupled with an allowance of 6% strength differential between a core with a cut surface relative to a cast cylinder. A strength reduction of 15% is also incorporated to allow for the weaker top surface zone of a corresponding cast cylinder, before conversion to an equivalent cube strength by the multiplication factor of 1.25. An 8% difference between vertical and horizontally drilled cores is also incorporated with the resulting expressions emerging.

- **Horizontally drilled core:**

$$\text{Estimated in-situ cube strength} = \frac{2.5f_{\lambda}}{1.5 + 1/\lambda}$$

- **Vertically drilled core:**

$$\text{Estimated in-situ cube strength} = \frac{2.3f_{\lambda}}{1.5 + 1/\lambda}$$

Where f_{λ} is the measured strength of a core with length /diameter = λ

It is interesting to note that, using these expressions, the strength of a horizontally drilled core of length/diameter $\lambda = 1$ will be the same as the estimated cube strength. The cube strengths evaluated in this way will be estimates of the actual in-situ strength of the concrete in a wet condition and may underestimate the strength of the dry concrete by 10–15%.

An average recommended relationship between in-situ concrete and standard specimens is that the ‘potential’ strength of a standard specimen made from a particular mix is about 30% higher than the actual ‘fully compacted’ insitu strength. If this value is used to estimate a potential strength for comparison with specifications, the uncertainty of the relationship must be remembered. Potential strength estimations are increasingly

unpopular due to the difficulties of accounting for all variable factors. The expressions for cube strength will change as follows:

Horizontally drilled core:

$$\text{Estimated potential cube strength} = \frac{3.25f_{\lambda}}{1.5 + 1/\lambda}$$

Vertically drilled core:

$$\text{Estimated potential cube strength} = \frac{3.0f_{\lambda}}{1.5 + 1/\lambda}$$

A worked example of evaluation of core results using the Concrete Society recommendations is given in Appendix of this book. ACI 318 suggests that an average in-situ strength of at least 85% the minimum specified value is adequate, and that cores may be tested after air-drying for 7 days if the structure is to be dry. This is based on equivalent cylinder strengths derived from ASTM C42 factors. The effect of the calculation method can be considerable, as illustrated in Figure 6.3, and this emphasizes the importance of agreement between all parties of the method to be used in advance of the testing.

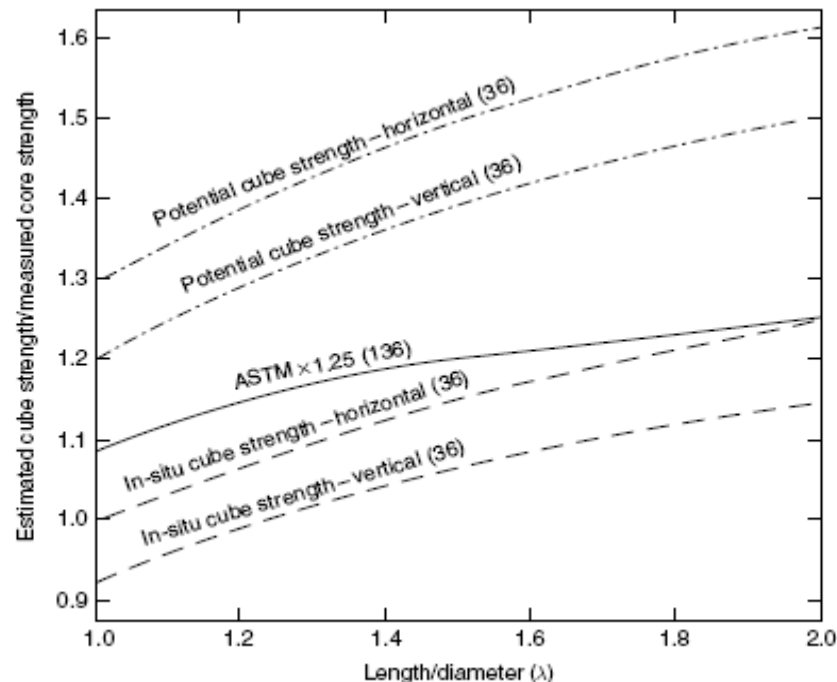

Figure 6-3: Effect of calculation method

6.3. Equipment

A core is usually cut by means of a rotary cutting tool with diamond bits, as shown in Figure 6.4. The equipment is portable, but it is heavy and must be firmly supported and braced against the concrete to prevent relative movement which will result in a distorted or broken core, and a water supply is also necessary to lubricate the cutter. Vacuum-assisted equipment can be used to obtain a firm attachment for the drilling rig without resorting to expansion bolts or cumbersome bracing. Uniformity of pressure is important, so it is essential that drilling is performed by a skilled operator. Hand-held equipment is available for cores up to 75mm diameter. A cylindrical specimen is obtained, which may contain embedded reinforcement, and which will usually be removed by breaking off by insertion of a cold chisel down the side of the core, once a sufficient depth has been drilled. The core, which will have a rough inner end, may then be removed using the drill or tongs, and the hole made good. A typical photograph of this type is shown in Figure 6-5. Cores should be securely wrapped in several layers of 'clingfilm' and then placed in a labelled polythene bag for return to the testing laboratory.

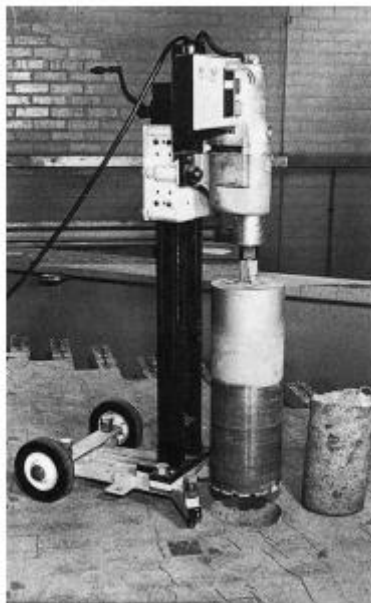

Figure 6-4: Core cutting drill



Figure 6-5: Typical core.

6.4. Procedure

- **Core size and location**

Where the core is to be used for compression testing, it is required that the diameter is at least three times the nominal maximum aggregate size. Since the compression test will be carried out for the core, a length/diameter ratio should be between 1.0 and 2.0.

- **Drilling**

A core is usually cut by means of a rotary cutting tool with diamond bits, as shown in Figure 6-4.

- **Testing**

Each core must be trimmed and the ends either ground or capped before visual examination, assessment of voidage, and density determinations.

- Visual examination

Aggregate type, size and characteristics should be assessed together with grading. These are usually most easily seen on a wet surface, but for other features to be noted, such as aggregate distribution, honeycombing, cracks, defects and drilling damage, a dry surface is preferable. Precise details of the location and size of reinforcement passing through the core must also be recorded. This estimated value of excess voidage will be required when attempting to calculate the potential strength. If a more detailed description of the voids is required, this should refer to small voids (0.5–3 mm), medium voids (3–6 mm) and large voids (>6mm) with the term ‘honeycombing’ being used if these are interconnected. It is also helpful to describe whether voids are empty, or the nature of their contents.

- **Trimming**
Trimming, preferably with a masonry or water-lubricated diamond saw, should give a core of a suitable length with parallel ends which are normal to the axis of the core. If possible, reinforcement and unrepresentative concrete should be removed.
- **Capping**
Core should be capped with high alumina cement mortar or sulfur–sand mixture to provide parallel end surfaces normal to the axis of the core. (Other materials should not be used as they have been shown to give unreliable results.) Caps should be kept as thin as possible, but if the core is hand trimmed they may be up to about the maximum aggregate size at the thickest points.
- **Density determination**

This is recommended in all cases, and is best measured by the following procedure:

- Measure volume (V_u) of trimmed core by water displacement
- Establish density of capping materials (D_c)
- Before compressive testing, weigh soaked/surface-dry capped core in air and water to determine gross weight W_t and volume V_t
- If reinforcement is present this should be removed from the concrete after compression testing, and the weight W_s and volume V_s determined
- Calculate saturated density of concrete in the uncapped core from

$$D_a = \frac{W_t - D_c (V_t - V_u) - W_s}{V_u - V_s}$$

If no steel is present, W_s and V_s are both zero. The value thus obtained may be used, if required, to assess the excess voidage of the concrete using the relationship

$$\text{Estimated excess voidage} = \frac{D_p - D_a}{D_p - 500} \times 100\%$$

Where D_p = the potential density based on available values for 28-day-old cubes of the same mix. In addition, D_a is the actual density.

- **Compression test**

The standard procedure in the United Kingdom is to test cores in a saturated condition; therefore, this procedure will be followed in BZU concrete laboratory. Hence, testing should be not less than two days after capping and immersion in water. The mean diameter must be measured to the nearest 1mm by caliper, with measurements on two axes at quarter- and mid-points along the length of the core, and the core length also measured to the nearest 1 mm. Compression testing will be

carried out at a rate within the range 12–24N/(mm².min) in a suitable testing machine and the mode of failure noted. If there is cracking of the caps, or separation of cap and core, the result should be considered as being of doubtful accuracy. Ideally cracking should be similar all round the circumference of the core, but a diagonal shear crack is considered satisfactory, except in short cores or where reinforcement or honeycombing is present.

The procedure for compression test was discussed in detail in chapter 2, so students can refer to that chapter and read the procedure.

6.5. Data Sheet

- The lab technician will give the required data sheet for this experiment. This paper will be added to this book as soon as it available.

Chapter Seven: Test on Asphalt and Bituminous Materials

Penetration Test

1. Introduction

Because of their excellent binding and water proofing properties, bituminous materials are largely used in roadway construction. Many factors like constituents, temperature and others affect the consistency of bituminous materials. Most of bituminous grades remain in semi-solid or in plastic manner at temperatures between 25 and 50 °C while having high viscosity which make them don't flow as liquid and, as such, can't be mixed with aggregates. However, some grades of cutback bitumen and bituminous emulsion are liquid within these ranges of temperature and need not heating when mixing them with aggregates.

The process by which the viscosity of bituminous materials determined is not simple. Indirect methods like penetration test are used to determine the consistency of paving grade bitumen. Bituminous materials are graded and classified depending on their origin and refining process. The penetration test is used to grade them by determining their consistency. The test is performed by measuring the depth (in units of one tenth of a millimeter or hundreds of centimeters) to which a standard needle will penetrate vertically under specified conditions of standard weight, temperature and duration. The total weight of the needle is 100 g and the sample is maintained at 25 °C for five seconds. The depth of the needle will be greater for softer bitumen. The test is very simple and quick to be performed.

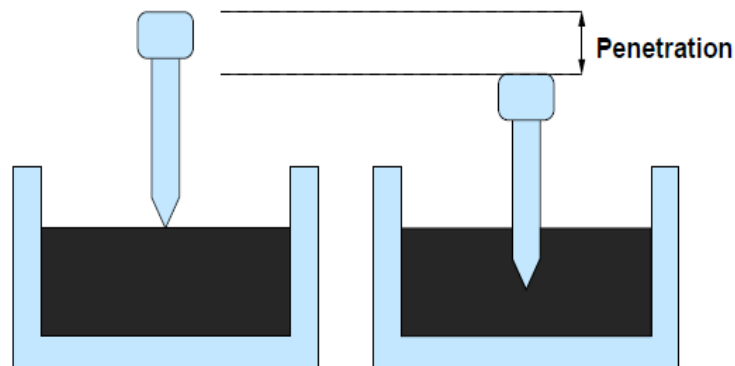

Figure 1 penetration test

2. Apparatus

The following apparatus are used to conduct the test:

- Penetrometer:

This consists of the standard penetration needle assembly and calibrated dial. Once released, the bitumen will be penetrated by the standard needle without considerable friction between them. The length of the needle is 50 mm and has a diameter of 1 mm with a pointed end. This end has conical shape with length of 5 mm (tapers from 1.0 mm to 0.15 mm diameter). The other end of the needle is fixed to a shank of 3 mm. The total weight of the needle assembly is 100 g. The penetration value is measured using calibrated dial in units of tenth of a mm. The test should be performed within duration of 5 seconds and standard temperature of 25 °C. Some penetrometers operate automatically where the test duration is automatically controlled. So, the needle is released, the assembly is operated for an exact duration of 5 seconds.

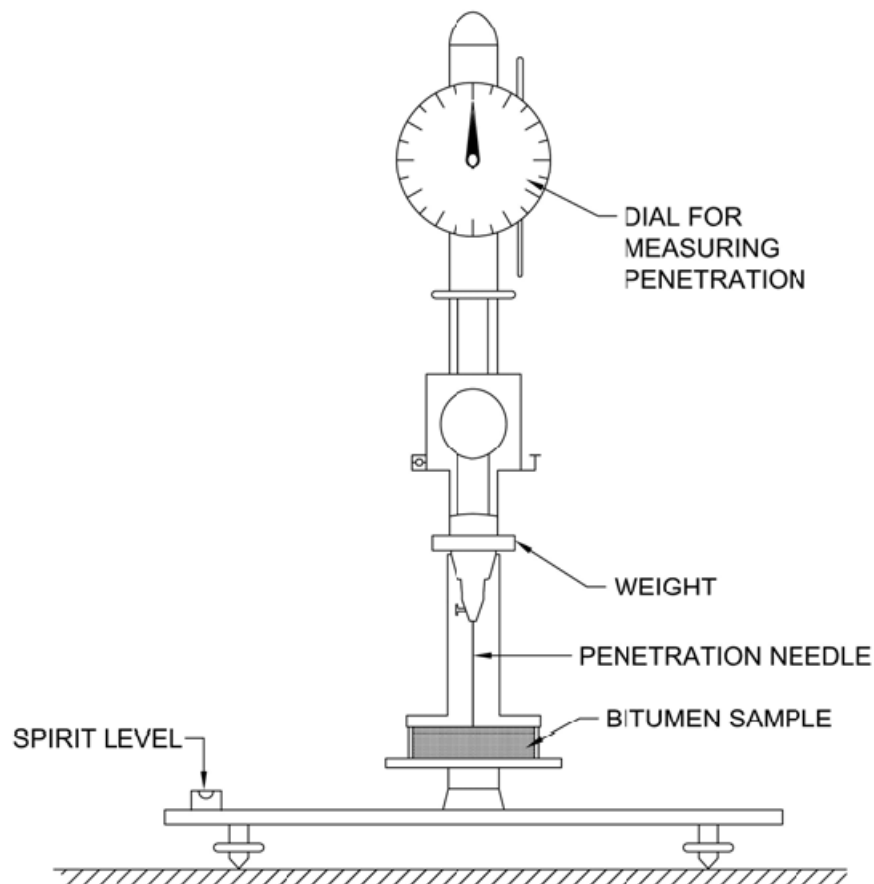

Figure 2 penetrometer

- Container:

The bitumen specimen is placed in a cylindrical metal or glass container of diameter 55 mm and depth of 33 mm. the cylinder base is flat and smooth. If the penetration value is more than 225, a container with 70 mm diameter and 45 mm depth may be used.

- **Water Bath:**
Bath contains at least 10 liters of water that is thermostatically controlled to keep the specimen at 25 ± 1 °C. The specimen should be immersed in the water to a depth of at least 100 mm and put of a perforated shelf placed at least 50 mm from the bottom of the water bath to eliminate any vibrations.
- **Thermometer:**
A thermometer that can read up to 0.2 °C may be used to measure the water temperature if the temperature is not automatically read.
- **Timer device:**
Stop watch with 0.1 second accuracy is used. If automatically controlled penetrometer is used, then no need for a stop watch.
- **Transfer tray:**
A small plate that can keep the bitumen container fully immersed in the water.

3. Procedures:

- I. The specimen should be prepared before being placed in the water bath. This can be done by heating the specimen to a pouring consistency (75 to 100 °C above bitumen softening point). The sample should be stirred thoroughly to make homogenous and free from air bubbles and water.
- II. The sample is poured in container of 35 mm depth (at least 15 mm more the expected penetration). And the sample contained is placed on transfer plate for 60 to 90 minutes in the room temperature.
- III. The sample and the transfer plate is placed in the water bath for a period of 60 minutes in 25 °C.
- IV. The sample container is removed from the water bath and placed under the needle of the penetrometer. The needle assembly is lowered until placed to just touch the top surface of the specimen. Failing to do so will result in errors in the penetration readings. The needle assembly is clamped in this position.
- V. Dial pointer is set to read zero using appropriate controller or the initial reading must be observed and recorded.
- VI. The needle is released for exactly 5 seconds by pushing a button on the penetrometer and the final reading is recorded. The needle is raised and the needle is removed.
- VII. The test should be repeated on the same sample to get three measurements. the locations between each trial should be spaced at least 10 mm and the minimum distance between the edge of the specimen (container wall) and the needle location should be 10 mm.

4. Results

The penetration value for each trial is calculated by taken the difference between the intial and final readings. The average value of the three consistent trials is determined. It should be noted that the penetration value is greatly affected by the following:

- Pouring temperature: higher pouring temperature would cause hardening of the bitumen and thus lower penetration values.
- Size of the needle
- The weight of the needle assembly: as the weight of the needle assembly increases, the depth of penetration will be increased.
- The test temperature: higher temperature than specified will result in higher penetration values.
- The duration of releasing the needle: if the penetration time is increased, then the needle would penetrate more of the specimen and increase the penetration depth.
- Period of cooling the specimen.

5. Applications of penetration test

Penetration test is one of the reliable tests that is adopted to determine the grade of the bitumen material by measuring its hardness. The test is widely used because of its simplicity and quickness of doing the experiment. The penetration grade of different types of bitumen materials is reported as 80/100, 30/40, 60/70 etc. 80/100 indicates the penetration value of various types of bitumen ranges from 80 to 100.

The penetration value of various types of bitumen materials ranges from 20 to 225. The suitable type is chosen based on climate conditions, the type of the construction. Harder grade of bitumen (lower penetration values) is used in warm region.

This test is not suitable for estimating the consistency of softer liquid materials like cutback or tars. The consistency of such materials is assessed by conducting viscosity test.

OBSERVATION SHEET

Results of Penetration Test

- i. Pouring Temperature, °C =
- ii. Period of cooling in atmosphere, minutes =
- iii. Room temperature, °C =
- iv. Period of immersing at test temp. , minutes =
- v. Actual test temperature, °C =

Readings	Sample NO.				Sample NO.			
	Test 1	Test 2	Test 3	Average	Test 1	Test 2	Test 3	Average
Penetrometer dial reading								
i. Initial								
ii. Final								
Penetration value								

Mean penetration value =

Grade of bitumen =

Remarks:

Ductility Test

1. Introduction

Bituminous materials should be ductile enough so that they form thin films around the aggregates when being used in the bituminous mixes. This will improve the physical interlocking of the aggregates. However, if the bituminous material doesn't possess sufficient ductility, it would crack and thus, the pavement surface would be pervious and this would result in damaging to the pavement structure. It should be noted that penetration and ductility properties are not the same. The chemical composition and the type of source of the bitumen determine the penetration and ductility properties of the bitumen. So, it is noted that certain bitumen might satisfy the penetration specification but not the ductility one. To ensure that both properties are satisfied in the field, both tests should be performed.

Ductility of bitumen may be understood as the property by which bitumen undergo great deformation or elongation. Ductility value is expressed as the distance in centimeters to which a standard briquette of the bitumen can be stretched before the thread breaks. So, one end of the specimen is pulled while the other is fixed in place until the specimen breaks. The test is performed at 25 ± 0.5 °C and a rate of pull of 50 ± 2.5 mm/min. Figure shows the ductility test concept.

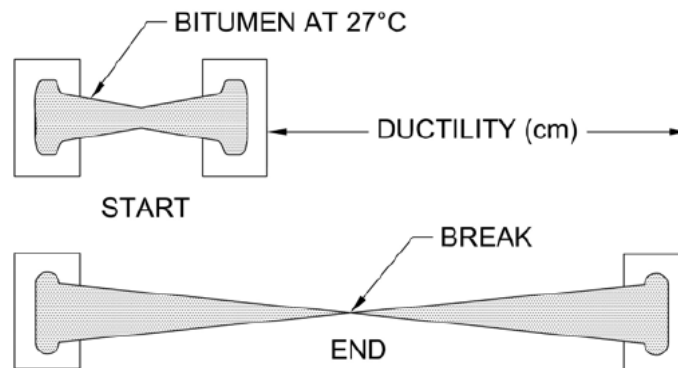

Figure 3 ductility test concept

2. Apparatus:

The following apparatus are used to conduct the ductility experiment:

- Briquette Mould:
A mold made of brass with shape and dimensions as shown in figure 4. There are circular holes at both ends of the mould which are used fix them with the testing machine.

- Ductility Machine:

It is a machine that operates at constant temperature of 25 °C water bath and a pulling device at standard rate of 50 ± 2.5 mm/min. A central threaded rod is connected to a motor that generate power which rotate the rod. A gear system provides movement to the movable end of the clip and the other end of the clip is held fixed in position.

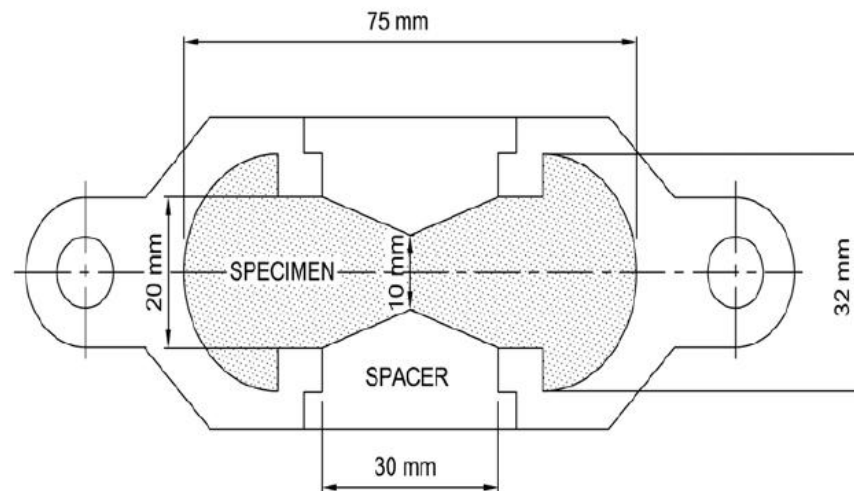

Figure 4 ductility test specimen and the mould

3. Procedures:

- I. The bitumen sample is melt to a temperature of 75 °C to 100 °C above the softening point (the material becomes soft above certain temperature) so that it becomes liquid. The molten bitumen is poured in the mould and placed on a brass plate.
- II. A mixture of equal parts of glycerin and dextrin is prepared. This mixture is applied to the brass mould to prevent the bitumen specimen from sticking to surface of the mould.
- III. The bitumen specimen is poured into the mould. Three samples are prepared and allowed to cool in the air for 40 minutes.
- IV. The assembly along with the sample is kept a water bath maintained at 25 °C for a period of about half an hour.
- V. The sides of the mould are removed and the assembly is secured in the machine. The pointer should read zero at the scale or alternatively, write down the initial reading. And the machine is switched on. One end of the mould will move while the other one will remain in fixed.
- VI. Observe the sample and note the distance when the specimen breaks. This will be the final reading.
- VII. If the reading doesn't stop until 75 cm, then the machine may be stopped and the ductility value is reported as greater than 75 cm.

The ductility value of bitumen depends on its grade. The table below indicates the ductility values for different grades of bitumen:

Grade	Ductility (cm)
S -35	50
S - 55	75
S - 65	75
S - 90	75
S - 200	75

Results:

The distance stretched by the moving end of the specimen up to the breaking point measured in cm is recorded as the ductility value. The average of the three tests is reported as the ductility of the specimens. All values should be consistent such that these values are within $\pm 5\%$ of the mean value.

The ductility value depends on the following factors:

- i. Test temperature.
- ii. Pouring temperature.
- iii. Dimensions of the briquette (especially the cross section of the test sample at the minimum width 10 X 10 mm).
- iv. Rate of pulling.
- v. Period of cooling.

Application of the ductility test:

The bitumen used in pavement mixture should achieve minimum ductility value which is considered essential for good pavement performance. Because the temperature increases and decreases repeatedly, deformations occur in bituminous pavements. Moreover, deformations occur due to friction between aggregates that results from the traffic loads. If the bitumen has low ductility, it will crack and defects happen in the pavement mixture. Ductility values ranges from 5 to 100. Usually, a minimum value of 50 or 75 cm is adopted for bituminous construction.

OBSERVATION SHEET

Table Results of Ductility Test

- i. Grade of bitumen =
- ii. Pouring temperature, °C =
- iii. Test temperature, °C =
- iv. Period of cooling, minutes,
 - a) In air =
 - b) In water bath before trimming =
 - c) In water bath after trimming =

Test Property	Briquette number			Mean Value
	1	2	3	
Ductility Value (cm)				

Remarks:

Viscosity Test

1. Introduction

Viscosity is one of the fluid properties of bituminous materials and it is defined as a measure of the resistance of fluid to flow. Or it is seen as the property that retards the flow of a liquid due to internal friction. So, high viscosity will slow the movement or rate of flow.

The paving mixes are greatly influenced by this characteristic. There is a suitable temperature range where viscosity is most appropriate to achieve good compaction of bituminous mix. Low or high values of this property during compacting or mixing may result in lower stability values. If the viscosity is low, the mix will resist compaction and it will be heterogeneous, hence low stability values. On the other hand, at low viscosity values, the bitumen will lubricate the aggregate particles instead of providing uniform film over aggregate.

Indirect methods like orifice type viscometers are used to indirectly find the viscosity of liquid binders like cutback and emulsions. Viscosity is expressed as the time in seconds taken by 50 ml bitumen sample to pass through the orifice of a cup, under standard test conditions and specified temperature.

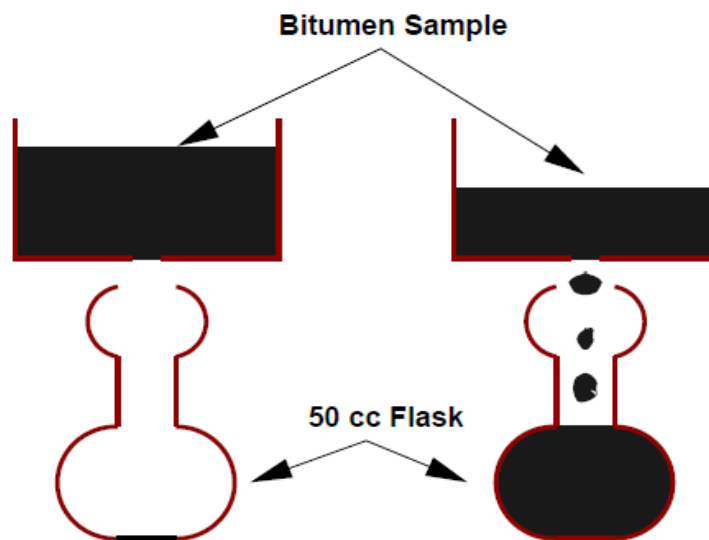

Figure 5 viscosity test concept

The ability of bituminous binder to spread, penetrate into the voids and coat the aggregate, and hence the properties of the pavement mixes, depends largely on the degree of fluidity of binder. Each type and grade of bitumen has suitable range of temperature where fluidity of viscosity is suitable to produce good paving mix.

The viscosity of liquid bituminous binders like tars and emulsion is tested by indirect method using orifice type viscometer. The viscosity value is the time taken in seconds to allow a specified quantity of binder to flow through specified orifice size of a cup at a given temperature. Viscosity of bitumen emulsion is determined using Saybolt Furol viscometer.

2. Apparatus

- Oil tube with over flow rim at the top and outlet orifice of internal diameter 3.15 mm and stopper cork at the bottom.
- Receiver with wide mouth and a marking neck denoting 50 ml volume of the liquid.
- Water bath that is thermostatically controlled.
- Stirring device.
- Support to hold the oil tube.
- Timing device with an accuracy of 0.1 second.
- Two thermometers to check the temperatures of the bath and the sample in the tube.



Figure 6 Saybolt Furol Viscometer.

3. Procedures

- I. Establish and control the bath temperature to be as the test temperature (25 °C).
- II. Insert a cork stopper into the air chamber at the bottom of the viscometer. Fit the cork tightly enough to prevent the escape of air so that no oil will be on the cork when it is withdrawn later.

- III. If the test temperature is above the room temperature, then heat the sample to not more than 1.7 °C above test temperature.
- IV. Stir the sample well and then strain it through 150 µm wire cloth in the filter funnel directly into the viscometer until the level is above the overflow rim.
- V. Stir the sample in the viscometer with the appropriate viscosity thermometer equipped thermometer support. When the temperature remains constant around the test temperature during 1 min of continuous stirring, remove the thermometer.
- VI. Check to be sure that the receiving flask is in the proper position, then snap the cork from the viscometer using attached chord and start the timer at the same instant.
- VII. Stop the time the instant the oil reaches the graduation mark on the receiving flask. Record the efflux time in seconds to the nearest 0.1 sec.

Indirect measure of viscosity is achieved by orifice viscometer. The higher the duration, the more viscous is the material. It should be noted that test result would be affected if the test temperature is not correctly maintained throughout the test. Fake results are obtained if the orifice is clogged or if lumps are present in the bituminous material sample.

OBSERVATION SHEET

Viscosity Tests

Absolute Viscosity of Bitumen

Type of bitumen =

Specified test temperature, °C =

Actual test temperature, °C =

Sample NO.	Time, t second for 50 ml flow	Saybolt – Furol viscosity, second

Remarks:

Extraction of bituminous binder

1. Introduction

This test method is used to determine the percentage of bitumen in hot-mixed paving mixture and pavement samples. The paving bitumen is extracted with benzene using extraction equipment applicable to this particular method. The bitumen content is calculated by difference from the mass of the extracted aggregate. The bitumen content is expressed as mass percent of the moisture free mixture.

2. Apparatus

- I. Oven, capable of maintain temperature at 110 ± 5 °C.
- II. Flat pan.
- III. Balance having accuracy of at least 0.01 % of the sample mass.
- IV. Extraction apparatus, consisting of bowl that can revolve at controlled speed 3600 r/min. the speed may be controlled manually or with a speed control. The apparatus should be provided with a container for catching the solvent thrown from the bowl and a drain for removing the solvent.
- V. Filter rings, felt or paper, to fit the rim of the bowl.

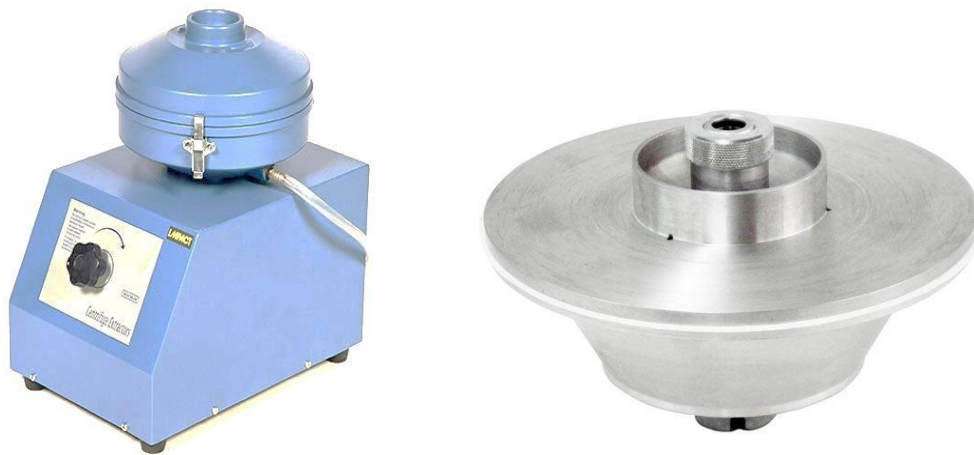

Figure 7 Centrifugal extractor

3. Procedures

- I. If the mixture is not sufficiently soft to separate with trowel, it should be place in a large flat pan and warmed to 110 ± 5 °C only until it can be handled or mixed. Split or quarter the specimen until the mass required is obtained. The table below presents the size of the sample required based on the nominal maximum aggregate size.

Nominal Maximum Aggregate Size Standard, mm	Minimum Mass of Sample Kg
4.75	0.5
9.5	1
12.5	1.5
19.0	2
25.0	3
37.5	4

- II. Place a weight (A) of 650 to 2500-g test portion into a bowl and cover it with piece of paper. Allow sufficient time for the solvent to disintegrate the test portion (not over one hour). The mass of the filter paper should be determined first.
- III. Place the bowl containing the test portion and the solvent in the extraction apparatus. Clamp the cover on the bowl tightly and place a beaker under the drain to collect the extract.
- IV. Start the centrifuge revolving slowly and gradually increase the speed to the maximum 3600 r/min or until the solvent ceases to flow from the drain. Allow the machine to stop.
- V. Add benzene again to the mix from the appropriate place to the bowl and leave it for approximately 1 hour so that it can disintegrate again with the paving mix. Repeat operating the machine as before. It should be noted that this procedures should be repeated until the color of the extract that comes out of the machine is not darker than straw color.
- VI. Remove the filter ring from the bowl and record carefully it weight along with all material held with it.

- VII. Remove all material from the bowl to pan of known weight. Place it in the oven with a temperature of 110 ± 5 °C for 24 hours and recorded the weight of the specimen (B).
- VIII. The weight of the bitumen extracted could be obtained by subtracting the weight of the sample obtained left in the bowl (B) from the original weight (A). So, the bitumen content could be easily expressed as a percentage.

OBSERVATION SHEET

Extraction of Bituminous Materials Test

Wt. of the sample before adding benzene (W1)	
Wt. of the sample after washing and drying in the oven (W2)	
Wt. of the filter before washing (W3)	
Wt. of the filter after washing and drying in the oven (W4)	

$$\text{Bitumenous \%} = \frac{W1 - 2 + W3 - W4}{W2 + (W3 - W4)} * 100\%$$

Remarks:

Chapter eight: Test on Metals

Hardness Test

1. Introduction

Hardness is the property of a material to resist plastic deformation, usually by penetration. In other words, it is a measure of resistance of how resistant a material is for permanent change in its shape when being subjected to compressive load. Hardness may also refer to stiffness or resistance to scratching, abrasion or cutting. The greater the hardness of a metal, the greater resistance it has to plastic deformation.

Indentation hardness tests are used to determine the hardness of a material to deformation. Hardness indentation is referred to the resistance of a material to indentation. In this usual type of hardness, a pointed or rounded indenter is pressed into a surface under a substantially static load.

2. Hardness measurement

Hardness could be measured as macro-, micro-, or nano- scale based on the forces applied and the resulted displacements. Macro-hardness is obtained using quick and simple method for bulk material from small sample. It is commonly used for quality control of surface treatments processes. Macro-hardness would not be used to test materials that have fine microstructure, non-homogenous, or prone to cracking. This is because such method will be highly variable and will not identify individual surface features. Instead, micro-hardness measurements are suitable.

Micro-hardness is determined by forcing an indenter into a surface of the material under 15 to 1000 gf load. The indentation is so small and they are measured by a microscope. Micro-indenter works by pressing a tip into a sample and continuously measuring the applied load, penetration depth and cycle time. Nano-indentation tests measure the hardness by indenting very small, on the order of 1 nano-Newton, indentation forces and measuring the depth of the indentation that was made.

3. Hardness measurement methods

Three types of tests are used to measure the hardness of metals. These are; the Brinell hardness test, the Rockwell hardness test and the Vickers hardness test. It can be generally assumed that strong metal is also a hard metal. The hardness of a metal is measured by determining the metal resistance to the penetration of a non-deformable ball or cone. So, the depth which a ball or cone will sink into under a given load and with specified period of time is determined.

3.1. Rockwell hardness test

This test measures the hardness based on the net increase in depth of the impression left by the load applied. The hardness is expressed in R, L, M, E and K scales. The depth of penetration of an indenter under certain test conditions is determined in this test. The indenter may be a steel ball of specified diameter or a spherical diamond-tipped cone of 120° angle and 0.2 mm tip radius called Brale. The type of the indenter and the test load determine the hardness scale. This test measures the difference in depth caused by two different forces using dial gauge. Plastics are measured using this method. A minor load e.g. 10 Kg is first applied, which causes an initial penetration. Then, the dial is set to zero and major load is applied, the depth reading is taken while removing of the major load and keeping the minor one. The hardness number may be read directly from hardness scale. The Rockwell hardness number (HR) is calculated as follows:

$$HR = E - e$$

F_0 = preliminary minor load in Kg.

F_1 = additional major load in Kg.

F = total load in Kg

e = permanent increase in depth of penetration due to major load F_1 measured in units of 0.002mm.

E = a constant depending on the form of indenter: 100 units for diamond indenter, 130 units for steel ball indenter.

HR = Rockwell hardness number

D = diameter of steel ball.

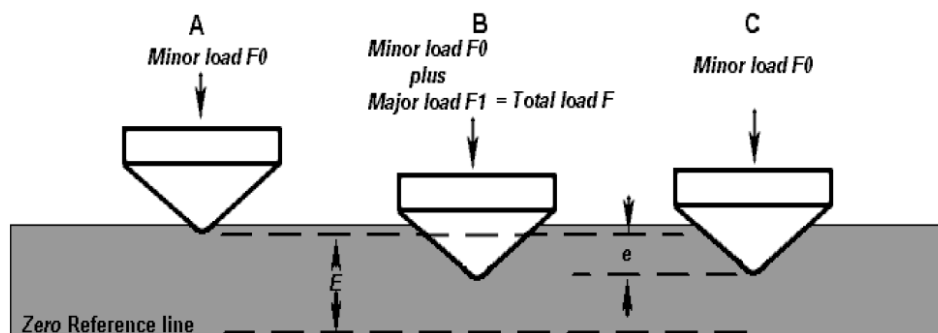

3.2. Brinell hardness test

In this method, the hardness is determined by measuring the diameter of the indentation left by forcing a hard steel or carbide sphere of specified diameter under specified load into the surface of a specimen. The Brinell hardness or Brinell number is obtained by dividing the applied load (Kg) by the actual surface area of indentation (mm^2). A desk top machine to press a 10mm diameter steel ball into the surface of the specimen by applying a load of 500 Kg for soft metals, 1500 Kg aluminum casting and 3000 Kg for materials such as iron and steel. The load is applied in a period of 10 to 15 seconds.

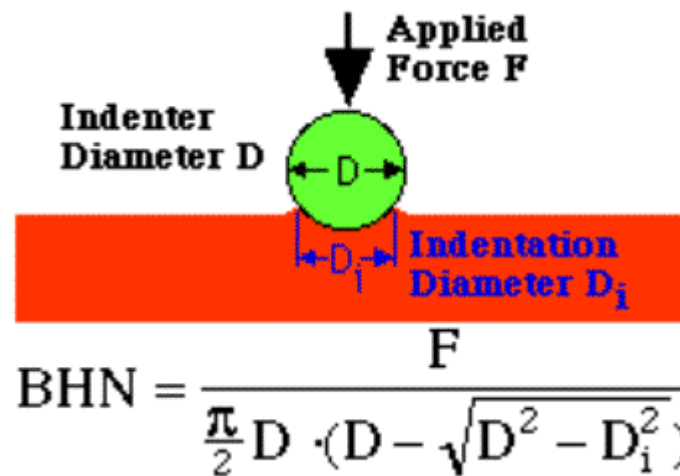

Figure 8 Hardness indentation using Brinell method

BHN = the Brinell hardness number

F = the imposed load in Kg

D = the diameter of the spherical indenter in mm.

D_i = the diameter of the resulting indenter impression in mm.

Several tests are usually carried out over an area in the specimen. Each test might result in different number because of the minor variation in quality of the specimen and due to the fact that the test relies on careful measurement of the diameter of the depression. Small errors in reading the diameter will lead to small variation in BHN values. As such, the test result is usually reported as a range of values rather than one single value.

3.3. Vickers Hardness test

This method is used to measure the hardness of metals with extremely hard surfaces. The specimen is subjected to a standard pressure for a standard length of time by means of a pyramid-shaped diamond. The Vickers hardness value is read from a conversion table that converts the diagonal of the resulting indentation measured under microscope. So, the size of the impression produced by a load caused by pyramid-shaped diamond indenter is used to measure the hardness of a material. The square-based indenter has opposite sides that meet at the apex at an angle of 136° . The diamond is pressed into the surface of the specimen at loads up to about 120 Kg where the size of the impression is measured using a calibrated microscope. The Vickers number (HV) is calculated using the following formula:

$$HV = 1.854(F/D_2)$$

HV = Vickers number

F = the applied load in Kg

D_2 = area of the indentation in mm^2

The Vickers test is reliable for measuring the hardness of metals and ceramic materials.

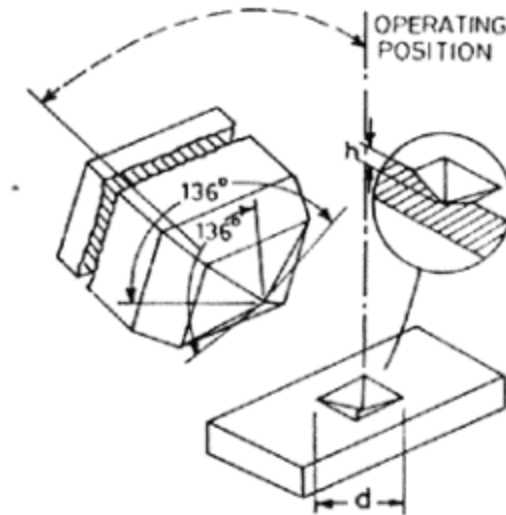

Figure 9 Hardness indentation using Vickers method

Bending test of reinforcing steel bars

1. Introduction

Reinforcing steel bars in reinforced concrete structures are mainly used to carry tensile stresses after the concrete cracks. This is because concrete has very high compressive strength **combined** with very low tensile strength. These reinforcing bars are sometimes subjected to bending and re-bending in the site before they can be used. This will result in loading and re-loading of the bars. Some structures like domes and shells require that bending of bars so that the shape of the structure can be achieved. Moreover, bars are bent at the beam - column joints. Bending test is a simple qualitative test that is used to evaluate the quality of the materials by their ability to resist cracking during continuous bend. ASTM E-290 covers the bending testing of bars primarily for evaluating their ductility. The bending specimen shall be tested by the naked eye to identify any cracks, open defects or surface irregularity that may appear at the convex surface.

If the specimen fractures, the material has failed the test. When complete fracture doesn't occur, the criterion for failure is the number of cracks or other surface irregularity seen by the unaided eye at the convex surface of the specimen after bending.

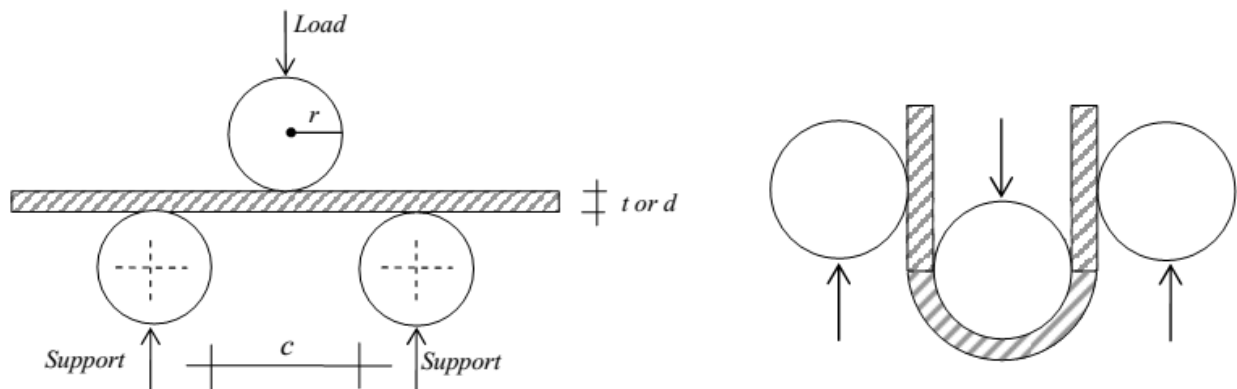

2. procedures

- I. The test set-up is shown in the figure. The bar being tested is supported by two pins with a distance of three times of the bar diameter plus the plunger. The plunger is placed midway between the supports and the bar is bent to an angle of 180° or 45° as intended. The testing machine is shown in the figure below.
- II. For the re-bend part, the bar has to be heated to a 100° for an hour, and then the bar is re-bended again.

- III. The specimen is checked in each case for any possible defects or cracks as explained earlier.

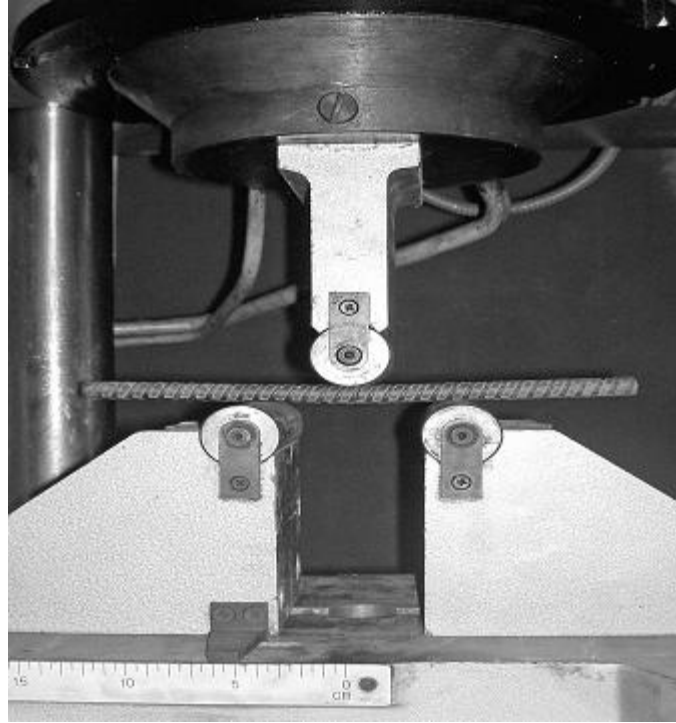

Figure 10 bend re-bend testing machine

Tension testing of reinforcing steel bars

tension test is one of the important tests conducted to determine properties of the steel reinforcing bars like yielding strength (σ_y), ultimate strength (σ_u), Young's Modulus (E) ... etc. The primary goal of performing tension test is to determine the relationship between average normal stress and average normal strain in reinforcing steel. Typical relationship is presented in the figure below:

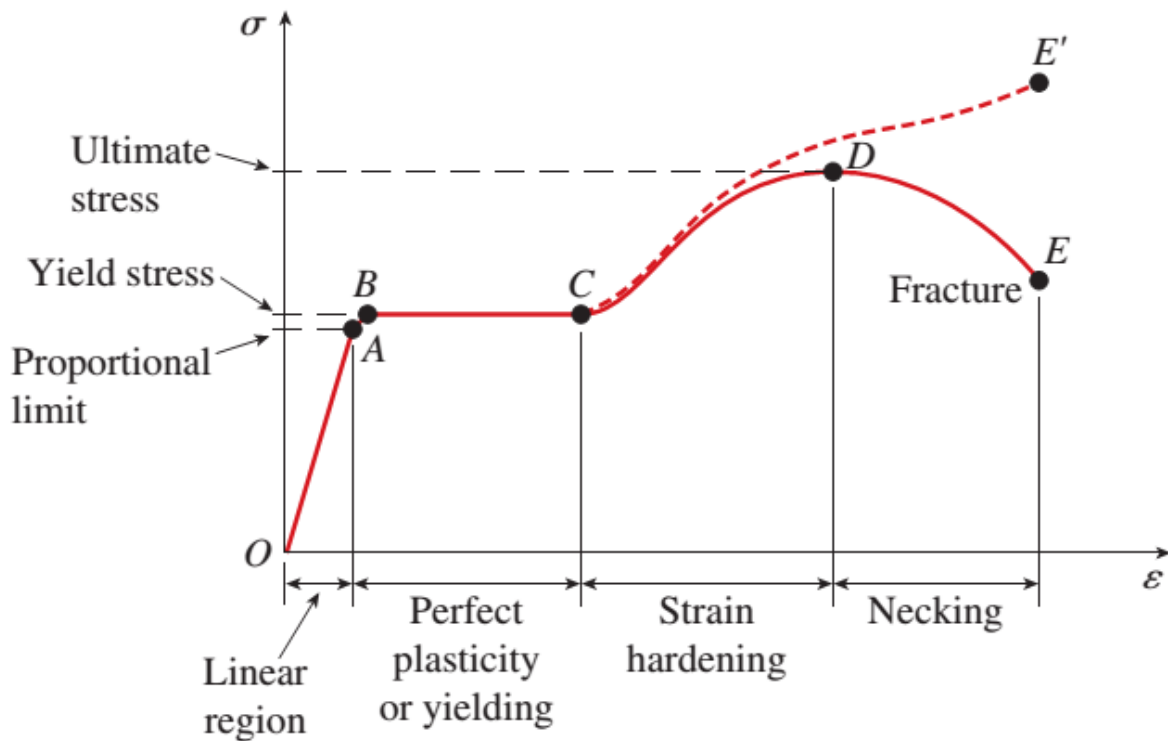

Figure 11 typical stress strain diagram

Test specimen is made into standard shape and size to perform the test. Two small punch marks are placed along the specimen length to measure the gauge-length distance L and the original cross sectional area A is recorded as well. An axial tension load (without bending) is applied at the end the specimen. The tension machine like the one shown in the figure below is used to stretch the specimen at slow constant rate until it fails. The machine is designed to read the load required to maintain uniform stretching of the sample.

The load P and the deformation δ is recorded by the machine at frequent intervals. δ is used then to determine the average normal strain in the specimen which is required to draw stress strain curve.



Figure 12 tension test machine

OBSERVATION SHEET

Tension Test of Mild Steel

Average diameter of specimen =

Area of cross section =

Gauge length =

Least count of extensometer =

0.4% of gauge length = (Div.)

Load, Kg	Elongation (Divisions)	Stress	Strain

Maximum load =

Breaking load =

Results:

Yield stress (0.2% proof stress) (from graph) =

Yield stress (at 0.4% of gauge length) (directly from the experiment) =

Modulus of elasticity =

Percentage elongation =

Tensile strength =

References

Bungey, J.H., Millard , S.G. and Grantham, M.G.(2006). **Testing of Concrete in Structures**. 4th ed. Taylor & Francis: London.

Department of Transportation (2006) **Aggregate Production and Testing: Construction Inspector's Training Manual**. Washington State, Department of Transportation. Environmental and Engineering Program, Construction office.

Kett, I. (2000),**Engineering Concrete: Mix Design and Test Methods**. CRC Press LLC: Washington D.C.

Kosmatka S.H. and Panarese W.C. (1994) **Design and Control of Concrete Mixtures**. 13th ed. Portland Cement Association: Illinois

Matls. I.M. (2002) **Aggregate Sampling Methods and Determination of Minimum Size of Samples for Sieve Analysis**. Office of materials. IOWA Department of Transportation

Mehta, P. K. and Monteiro, P. J. M.(2006). **Concrete Microstructure, Properties, and Materials**. Department of Civil and Environmental Engineering. University of California at Berkeley. 3rd ed. McGraw-Hill: New York.

Multi-Regional Aggregate Training and Certification Group.(2006) **Aggregate Technician Training Manual: Aggregate Sampling and Testing for Transportation Engineering Technicians**. AASHTO Standard Test Methods.

Newman J. and Choo B. S.(2003). **Advanced Concrete Technology: Constituent Materials**. Butterworth-Heinemann, An imprint of Elsevier: Oxford

Singh, A. and Gautam K. (2004), **Comparison Of ISI and ACI Methods For Absolute Volume Concrete Mix Design**. University of Hawaii at Manoa, USA.

Road Research Laboratory, **Bituminous Materials in Road Construction**, H.M.S.O., London

Roberts, F.L, Kandhal, P.S, Brown E.R, Lee, D.Y and Kennedy, T.W, **Hot Mix Asphalt Materials, Mixture Design and Construction**, (Second Edition 1996), NAPA Education Foundation, Maryland.

Shell Bitumen, **Shell Bitumen Hand Book**, (Fifth Edition), Thomas Telford Publishing, London

ASTM D5 / D5M – 13: Standard Test Method for Penetration of Bituminous Materials.

ASTM D445 – 15a: Test Method for Kinematic Viscosity of Transparent and Opaque Liquids (and Calculation of Dynamic Viscosity).

ASTM D445 – 15a: Standard Test Method for Kinematic Viscosity of Transparent and Opaque Liquids (and Calculation of Dynamic Viscosity).

ASTM D113 – 07: Standard Test Method for Ductility of Bituminous Materials.

ASTM D2172 / D2172M – 11: Standard Test Methods for Quantitative Extraction of Bitumen from Bituminous Paving Mixtures.

ASTM E18 – 16: Standard Test Methods for Rockwell Hardness of Metallic Materials.

ASTM E92 – 16: Standard Test Methods for Vickers Hardness and Knoop Hardness of Metallic Materials.

ASTM E10 - 15a: Standard Test Method for Brinell Hardness of Metallic Materials.

ASTM E290 – 14: Standard Test Methods for Bend Testing of Material for Ductility.

ASTM E8 / E8M - 16a: Standard Test Methods for Tension Testing of Metallic Materials.

Appendices

A: Measurement Conversion Factors between the S.I. System and the U.S. Standard Units

Table 18 Partial List of Factors to Convert the U.S. Standard Units of Measurements to the S.I. System^a

<i>Convert From</i>	<i>Multiply By</i>	<i>Dimension Obtained</i>
cubic feet	0.028317	cubic meters
cubic yards	0.76456	cubic meters
feet	30.480	centimeters
feet	0.30480	meters
gallon (U.S.)	3.77853	liters
inches	2.5400	centimeters
miles (U.S.)	1.6093	kilometers
ounces	28.349	grams
pounds	453.59	grams
pounds	0.45359	kilograms
quarts	0.94633	liters
square feet	0.092903	square meters
square inches	6.4516	square centimeters
square yards	0.83613	square meters
stress (ksi)	6.8948	megapascals (MPa)
stress (psi)	6,894.8	pascals (Pa) ^b
stress (psi)	0.0068948	megapascals (MPa)
temperature (°F)	$t_c = (t_f - 32)/1.8$	degree Celsius (°C)
temperature (°F)	$t_k = (t_f + 459.7)/1.8$	degree Kelvin (°K)
temperature (°K)	$t_c = t_k - 273.2$	degree Celsius (°C)
tons (short)	0.90718	metric tons
yards	0.91440	meters

a: For a complete guide to the S.I. System, refer to ASTM Designation: E 380.

b: One pascal (Pa) = 1 Newtons per meter square, N/m². Since the pascal is a very small quantity, in practice, one uses multiples of this unit, namely, the kilopascal (kPa = 10³ N/m²), the mega Pascal (MPa = 10⁶ N/m²), and the gigapascal (GPa = 10⁹ N/m²).

B: Additional Copies of Laboratory Data Sheets

1-Seive analysis data sheet

<i>Sample Number</i>				<i>Sample Number</i>			
<i>Sieve Size</i>	<i>Weight Retained (g)</i>	<i>% Retained</i>	<i>% Passing</i>	<i>Sieve Size</i>	<i>Weight Retained (g)</i>	<i>% Retained</i>	<i>% Passing</i>
2 in.				2 in.			
1 1/2 in.				1 1/2 in.			
1 in.				1 in.			
3/4 in.				3/4 in.			
1/2 in.				1/2 in.			
3/8 in.				3/8 in.			
#4				#4			
#8				#8			
#16				#16			
#30				#30			
#50				#50			
#100				#100			
#200				#200			
Pan				Pan			
Total				Total			
a. Wt. of sample (g)	-			a. Wt. of sample (g)	-		
b. Wt. of sample after washing (g)	-			b. Wt. of sample after washing (g)	-		
c. Loss in washing, (a - b) (g)	-			c. Loss in washing, (a - b) (g)	-		
d. Pan from dry sieve (g)	-			d. Pan from dry sieve (g)	-		
Total: 200, (c + d) (g)	-			Total: 200, (c + d) (g)	-		

Figure B-1: Wash and Dry Sieve Analysis — Sieve Analysis for Fine and Coarse Aggregates (ASTM C136) and Mineral Aggregates by Washing (ASTM C117)

2- Specific gravity data sheet

Coarse Aggregates — ASTM Designation: C 127				
Passing _____ Sieve and Retained on _____ Sieve	Sample 1	Sample 2	Sample 3	Sample 4
(A) Wt. oven-dry sample (g)				
(B) Wt. SSD sample (g)				
(C) Wt. saturated sample in water (g)				
Bulk specific gravity				
Apparent specific gravity				
Effective specific gravity				
Absorption (%)				
Average values: bulk sp. gravity = ; apparent sp. gravity = ; effective sp. gravity = ; absorption = .				
Fine Aggregates — ASTM Designation: C 128				
(A) Wt. oven-dry sample (g)				
(B) Wt. pycnometer + water to calibration mark (g)				
(C) Pycnometer + water + sample to calibration mark (g)				
Bulk specific gravity				
Apparent specific gravity				
Effective specific gravity				
Absorption (%)				
Average values: bulk sp. gravity = ; apparent sp. gravity = ; absorption = .				

Figure B-2: Coarse and Fine Aggregates Specific Gravity Data Sheet (ASTM Designations: C 127 and C 128)

5-Splitting tensile strength

Date of Test: Date Specimens were Cast: Description of Specimen: Length of Specimen, m or in. = Diameter of Specimen in m or in. = f'_c of Concrete Mix Tested under ASTM Designation: C 39 =				
Specimen Number	Max. Load, Kg (mass) or lb/f	Splitting Strength, kPa or psi	Percent f'_c	Remarks

Note: $T = (2 \times P) / (\pi \times l \times d)$

Figure B-5: Data sheet

6- Flexural strength of concrete using simple beam with third point loading

Date specimens were cast: _____ ; Comments: _____							
Description of test specimens: _____ ; Distance between supports: _____							
Specimen No.	Days Cured	Average <i>b x d</i> cm or in.	Load kg/lb	Location of Fracture	M.R. MPa/psi	% f'_c	Remarks
1							
2							
3							
Average							
4							
5							
6							
Average							
7							
8							
9							
Average							
10							
11							
12							
Average							

Figure B-6: Data sheet

7- Air content of freshly mixed concrete by pressure method

Air Content of Fresh Mixed Concrete by the Pressure Method
Weight of measuring bowl and water in kg or lb =
Net weight of measuring bowl in kg or lb =
Volume of measuring bowl in m ³ or yd ³ =
Quantity of F.A. required for test, $F_s = \text{Bowl volume}/\text{batch volume} \times \text{F.A. in batch in kg or lb} =$
Quantity of C.A. required for test, $C_s = \text{Bowl volume}/\text{batch volume} \times \text{C.A. in batch in kg or lb} =$
G =
H1
Hs

Table B-7: Illustrative example for Air content of fresh mixed concrete by the pressure method's data sheet

8-Rebound Number of Hardened Concrete by the Swiss hammer

Test number	Readings	Remarks
1		
2		
3		
4		
5		
6		
7		
8		
9		
10		
Average of 10 readings =		
Reading nos. discarded,=		
New average =		
Concrete compressive strength, kPa or psi =		

Table B-8: Example for the data sheet

C: Example of evaluation of core results

A 100mm diameter core drilled horizontally from a wall of concrete with 20mm maximum aggregate size contains one 20mm reinforcing bar normal to the core axis and located at 35mm from one end. Measured water-soaked concrete density = 2320kg/m³ after correction for included reinforcement.

- Measured crushing force = 160kN (following BS EN 12504 (135) procedure)
- Failure mode – normal.
- Measured core length after capping = 120mm.

- **Concrete Society in-situ cube strength**

$$\text{Measured core strength} = \frac{160 \times 10^3}{\pi \times \frac{100^2}{4}} = 20.5 \text{ N/mm}^2$$

$$\text{Core length/diameter ratio} = 120/100 = 1.2$$

$$\text{Estimated in-situ cube strength} = \frac{2.5}{1.5 + \frac{1}{1.2}} \times 20.5 \text{ for a horizontal core}$$

$$= 22 \text{ N/mm}^2$$

$$\text{Reinforcement correction factor} = 1 + 1.5 \left(\frac{20}{100} \times \frac{35}{120} \right)$$

$$= 1.09$$

$$\text{Corrected in-situ cube strength} = 22 \times 1.09 \text{ N/mm}^2 \pm 12\% \text{ for an individual result}$$

$$= 24.0 \pm 3 \text{ N/mm}^2$$

- **Concrete Society potential cube strength**

$$\text{Measured core strength} = 20.5 \text{ N/mm}^2$$

$$\text{Core length/diameter ratio} = 1.2$$

$$\text{Estimated potential cube strength} = \frac{3.25}{1.5 + \frac{1}{1.2}} \times 20.5 \text{ for a horizontal core}$$

$$= 28.5 \text{ N/mm}^2$$

$$\text{Reinforcement correction factor} = 1.09$$

$$\text{Potential density of concrete} = 2350 \text{ kg/m}^3 \text{ (mean value from cubes)}$$

$$\text{Excess voidage} = \left(\frac{2350 - 2320}{2350 - 500} \right) \times 100\% \\ = 1.6\%$$

$$\text{Strength Multiplying factor} = 1.14$$

$$\text{Corrected Potential cube strength} = 28.5 \times 1.09 \times 1.14 \\ = 35.5 \text{ N/mm}^2$$

(*Note:* Accuracy cannot be realistically quoted for a single result but the mean estimated potential cube strength from a group of at least four cores may be quoted to between $\pm 15\%$ and $\pm 30\%$ subject to a procedure described by Technical Report No. 11 to eliminate abnormally low results. In this instance because of the use of reinforcement and excess voidage correction factors, the estimated accuracy for a group of four is unlikely to be as high as $\pm 15\%$).

