

Reinforced Concrete Drawings

Chapter

3

Basics and Concepts

Part 2
Section

3.1

A. Introduction - SIMPLE THEORY

- Reinforced concrete is a combination of concrete and steel. Concrete is very strong in compression, but relatively weak in tension. Beams or columns made from plain concrete would have to be very large. By placing steel bars in those parts of the concrete subject to tension, acceptable sizes can be obtained.
- The reinforced concrete detailer should have an understanding of the behavior of the structural members under simple loading conditions to be able to locate the main reinforcement.

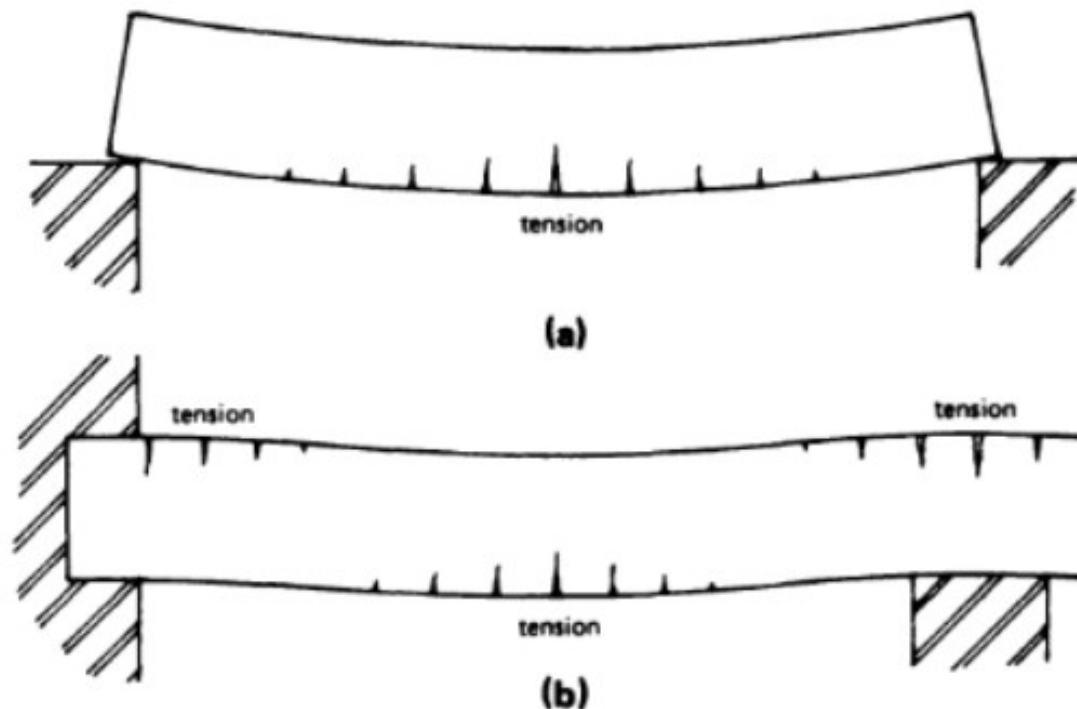

Introduction - SIMPLE THEORY

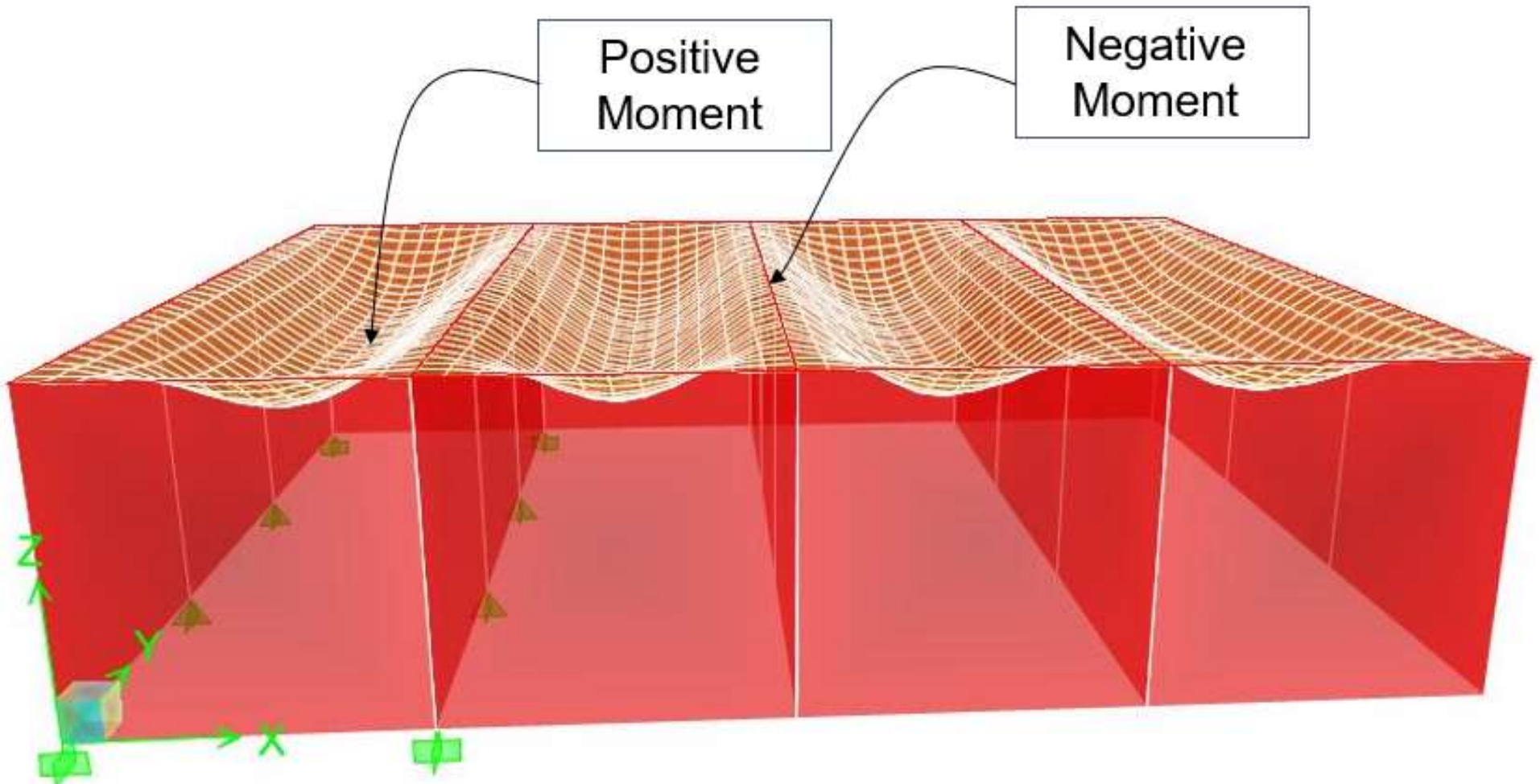

Introduction - SIMPLE THEORY

However;

- In more advanced work, reinforcement is also used to carry some of the compressive load in the concrete to further reduce the size of members.
- Reinforced concrete must have some reinforcement for reasons other than strength. In the case of the beam shown in figure stirrups will collapse when the concrete is placed, unless they are made into a rigid 'cage'. This is done by adding hanger bars, which complete the cage and hold the stirrups during the concreting operation. The hanger bars can be quite small.

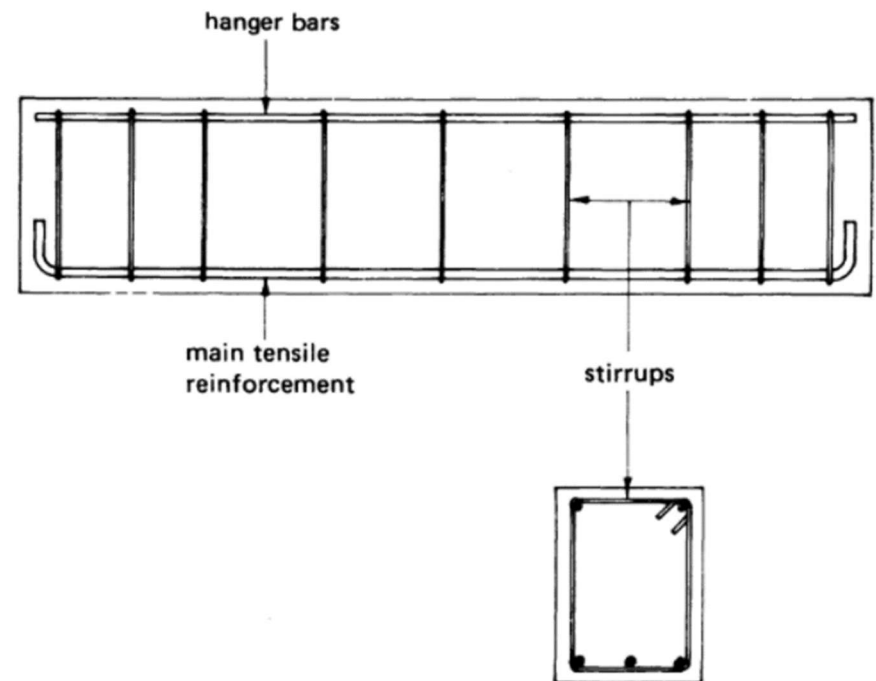

Introduction - SIMPLE THEORY

- Minimum steel is also required to control cracks in concrete (shrinkage, temperature ...).
- Reinforcement also enhance ductility of concrete which is extremely important in seismic design.

But:

Reinforcement amount shall be limited as excessive reinforcement can initiate brittle, sudden failure

Introduction - Types of drawings

The main purpose of preparing concrete structural drawings is to explain the shape and position of all the parts of the structure. Such drawings are used to progress the Architect's concept and then to enable construction of the structure on site. The drawings consists of:

- 1. General arrangement drawings:** plans, sections and elevations showing layout, dimensions and levels of all concrete members within the structure. The drawings also shows the location of all holes, openings and items affecting the concrete work in addition to notes on specifications, finishes and the north point
- 2. Reinforcement drawings:** describe and locate the reinforcement in relation to the outline of the concrete work. Reinforcement drawings are primarily for the use of the steel fixers. It is preferable that general arrangement and reinforcement drawings be kept separate, but for simple structures a combined drawing may be appropriate.
- 3. Standard details:** those details that are used on a repetitive basis.

Introduction - List of drawings

For a typical concrete building project the structural drawings usually include:

- General notes
- Center lines of the structural elements.
- Foundation Plan and details
- Ground beams and slab on grade
- Columns and walls details
- Floors plans
- Framing details (beams and joints)
- Stair case details
- External works details

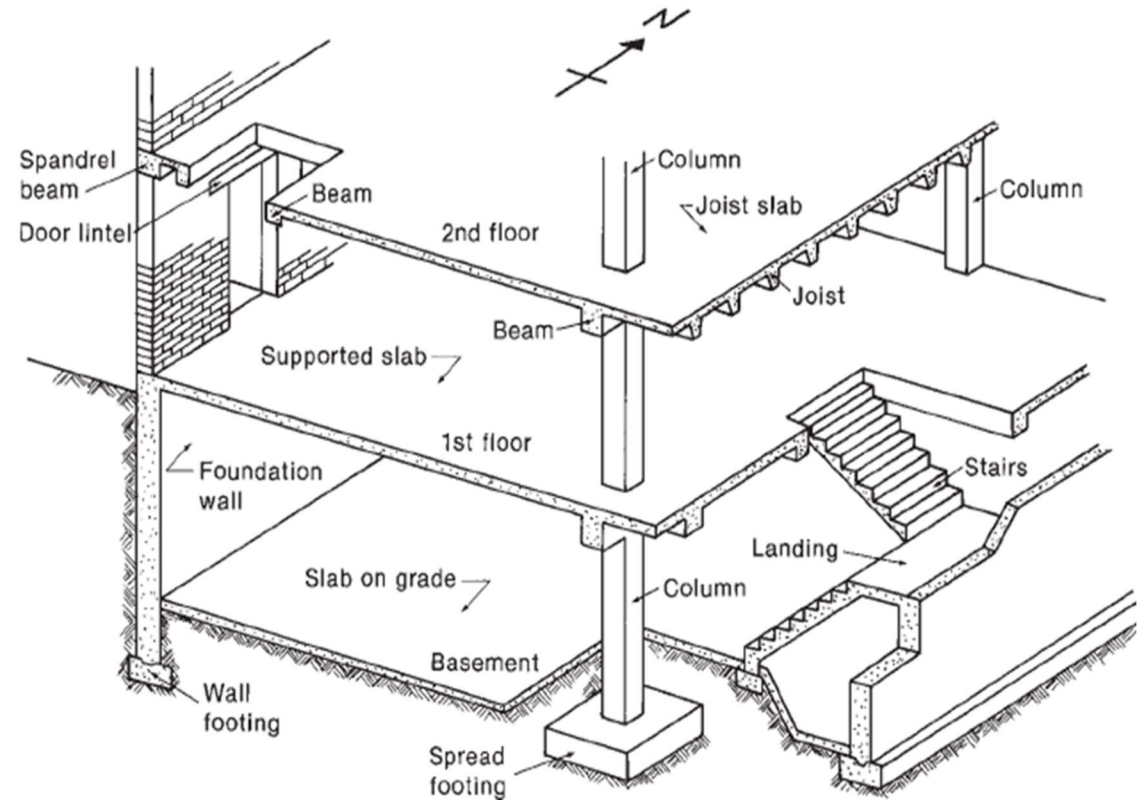

B. Standards of practice

Detailing Standards

- ACI Detailing Manual
- BS / EU Standards

EUROPEAN STANDARD **EN 1992-1-1**
NORME EUROPÉENNE
EUROPÄISCHE NORM

December 2004

ICS 91.010.30; 91.080.40

Incorporating corrigenda January 2008 and November 2010
Supersedes ENV 1992-1-1:1991, ENV 1992-1-3:1994,
ENV 1992-1-4:1994, ENV 1992-1-5:1994, ENV 1992-1-6:1994, ENV 1992-3:1998

English version

Eurocode 2: Design of concrete structures - Part 1-1: General rules and rules for buildings

Eurocode 2: Calcul des structures en béton - Partie 1-1 : Règles générales et règles pour les bâtiments

Eurocode 2: Bemessung und konstruktion von Stahlbeton- und Spannbetontragwerken - Teil 1-1: Allgemeine Bemessungsregeln und Regeln für den Hochbau

This European Standard was approved by CEN on 16 April 2004.

CEN members are bound to comply with the CEN/CENELEC Internal Regulations which stipulate the conditions for giving this European Standard the status of a national standard without any alteration. Up-to-date lists and bibliographical references concerning such national standards may be obtained on application to the Central Secretariat or to any CEN member.

This European Standard exists in three official versions (English, French, German). A version in any other language made by translation under the responsibility of a CEN member into its own language and notified to the Central Secretariat has the same status as the official versions.

CEN members are the national standards bodies of Austria, Belgium, Cyprus, Czech Republic, Denmark, Estonia, Finland, France, Germany, Greece, Hungary, Iceland, Ireland, Italy, Latvia, Lithuania, Luxembourg, Malta, Netherlands, Norway, Poland, Portugal, Slovakia, Slovenia, Spain, Sweden, Switzerland and United Kingdom.

ACI DETAILING MANUAL-2004

Including:

- Details and Detailing of Concrete Reinforcement (ACI 315-99)
- Manual of Structural and Placing Drawings for Reinforced Concrete Structures (ACI 315R-04)
- Supporting Reference Data

ACI COMMITTEE 315 DETAILS OF CONCRETE REINFORCEMENT

Ronald D. Flach
Chair

Anthony L. Felder
Secretary

Richard H. Birley
Charles K. Davidson
Robert E. Doyle
Gustav G. Erlemann
Paul Gordon
Bruce H. Hirsch
David F. Horton
Dennis L. Hunter

Robert W. Johnson
David W. Johnston
David G. Kittridge
Douglas D. Lee
A. Murray Lount
Javed B. Malik

Paul Nims
Vice Chair
Peter Meza
Donald E. Milks
David Niday
Roy H. Reiterman
Thomas G. Schmaltz
William G. Sebastian, Jr.
Milton R. Sees
Avanti C. Shroff



American Concrete Institute
Advancing concrete knowledge

PUBLICATION SP-66 (04)
AMERICAN CONCRETE INSTITUTE
FARMINGTON HILLS

Standards of practice - Thickness of lines & Scales

- The following suggested line thicknesses are considered suitable for reinforced concrete drawings.

Line Type	Thickness, mm
Concrete outlines generally and general arrangement drawings	0.35
Concrete outlines on reinforcement drawings	0.35
Main reinforcing bar	0.7
Links	0.35 – 0.7
Dimension lines and centerlines	0.25

- The following scales are recommended as a suitable for concrete work

Drawing	Scale
General arrangement (as plans)	1:100
Wall and Slab detail	1:50
Beam and Column elevations	1:50
Beam and column sections	1:20

T = TOB BARS

B = BOTTOM BARS

BU = BENT UP BARS

Standards of practice

Reinforcement Cover (C)

- It is essential for the steel bars to be protected by a sufficient layer of concrete, known as 'cover', to protect them from moisture that will rust the steel, and from the heat of any fire that could degrade the steel and lead to a structural collapse.
- The amount of cover will depend upon the quality of the concrete and the degree of exposure to the elements in the case of rusting. For fire resistance it will depend upon the length of time that the structure is required to resist a fire, the type of concrete aggregate and whether any additional protective covering is to be provided. The following table show the minimum required cover according to ACI 318

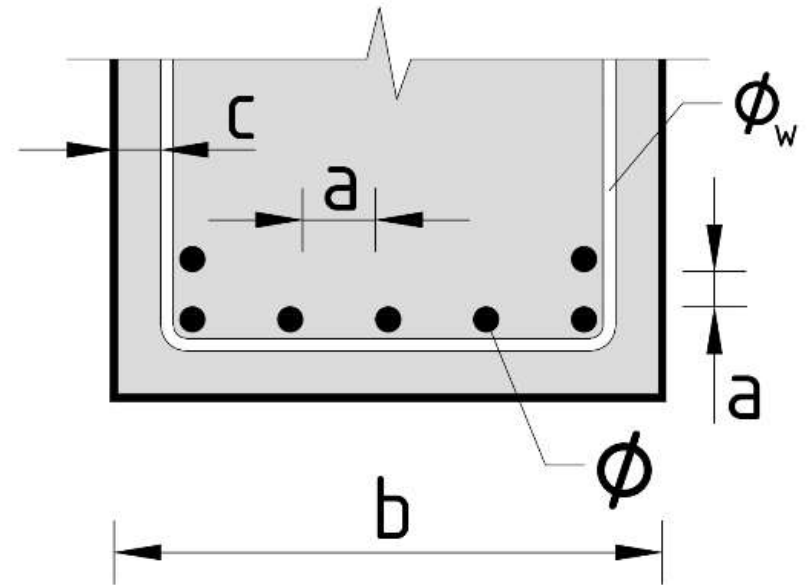

Standards of practice

ASTM STANDARD REINFORCING BARS

Bar size, no.*	Nominal diameter, mm	Nominal area, mm ²	Nominal mass, kg/m
10	9.5	71	0.560
13	12.7	129	0.994
16	15.9	199	1.552
19	19.1	284	2.235
22	22.2	387	3.042
25	25.4	510	3.973
29	28.7	645	5.060
32	32.3	819	6.404
36	35.8	1006	7.907
43	43.0	1452	11.38
57	57.3	2581	20.24

*Bar numbers approximate the number of millimeters of the nominal diameter of the bar.

Bar size (mm)	Cross-section (mm ²)	Mass per metre run (kg/m)
6	28.3	0.222
8	50.3	0.395
10	78.5	0.616
12	113.1	0.888
16	201.1	1.579
20	314.2	2.466
25	490.9	3.854
32	804.2	6.313
40	1256.6	9.864
50	1963.5	15.413

Table 20.6.1.3.1—Specified concrete cover for cast-in-place nonprestressed concrete members

Concrete exposure	Member	Reinforcement	Specified cover, mm
Cast against and permanently in contact with ground	All	All	75
		No. 19 through No. 57 bars	50
Exposed to weather or in contact with ground	All	No. 16 bar, MW200 or MD200 wire, and smaller	40
		No. 43 and No. 57 bars	40
Not exposed to weather or in contact with ground	Slabs, joists, and walls	No. 36 bar and smaller	20
		Primary reinforcement, stirrups, ties, spirals, and hoops	40
	Beams, columns, pedestals, and tension ties		

Locally available reinforcing bars

Standards of practice

Spacing limits for reinforcement (a)

- The minimum clear spacing between parallel bars in a layer shall be at least the greatest of d_b , $4/3d_{agg}$, and 25 mm.
- Where parallel reinforcement is placed in two or more layers, bars in the upper layers shall be placed directly above bars in the bottom layer with clear distance between layers not less than 25 mm.
- In spirally reinforced or tied reinforced compression members, clear distance between longitudinal bars shall be not less than $1.5d_b$, $4/3d_{agg}$ nor less than 40 mm.

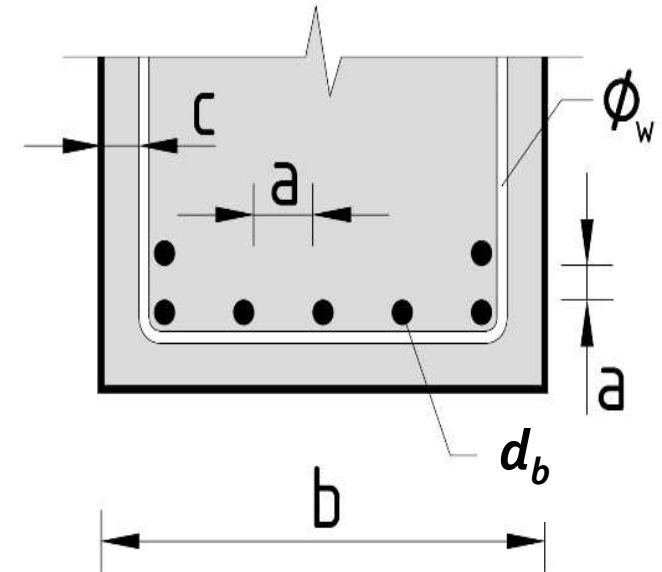

Standards of practice

Standard hooks and bend diameter

Table 25.3.1—Standard hook geometry for development of deformed bars in tension

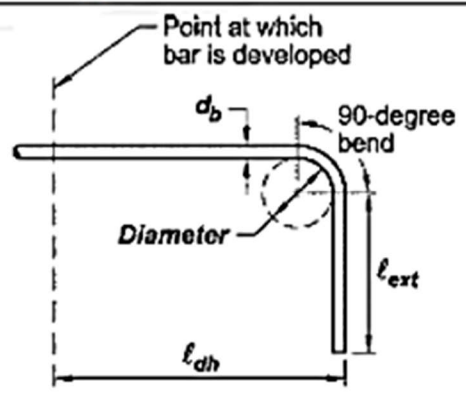
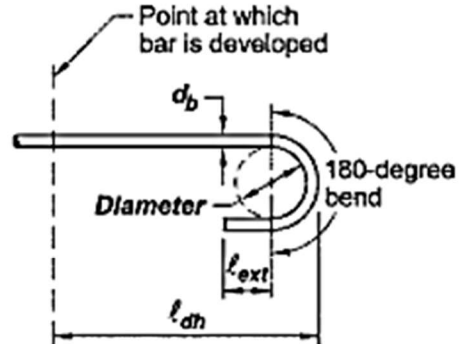
Type of standard hook	Bar size	Minimum inside bend diameter, mm	Straight extension ⁽¹⁾ ℓ_{ext} , mm	Type of standard hook
90-degree hook	No. 10 through No. 25	$6d_b$	$12d_b$	
	No. 29 through No. 36	$8d_b$		
	No. 43 and No. 57	$10d_b$		
180-degree hook	No. 10 through No. 25	$6d_b$	Greater of $4d_b$ and 65 mm	
	No. 29 through No. 36	$8d_b$		
	No. 43 and No. 57	$10d_b$		

⁽¹⁾A standard hook for deformed bars in tension includes the specific inside bend diameter and straight extension length. It shall be permitted to use a longer straight extension at the end of a hook. A longer extension shall not be considered to increase the anchorage capacity of the hook.

Standards of practice

Standard hooks and bend diameter

Table 25.3.2—Minimum inside bend diameters and standard hook geometry for stirrups, ties, and hoops

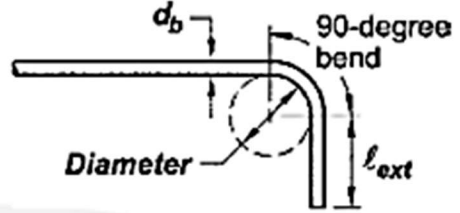
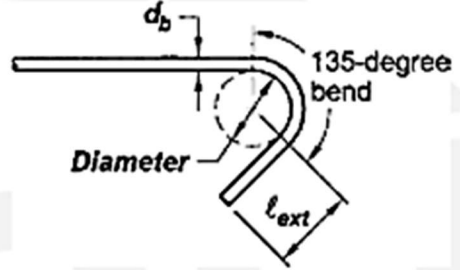
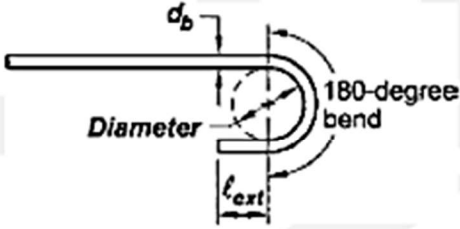
Type of standard hook	Bar size	Minimum inside bend diameter, mm	Straight extension ^[1] ℓ_{ext} mm	Type of standard hook
90-degree hook	No. 10 through No. 16	$4d_b$	Greater of $6d_b$ and 75 mm	
	No. 19 through No. 25	$6d_b$	$12d_b$	
135-degree hook	No. 10 through No. 16	$4d_b$	Greater of $6d_b$ and 75 mm	
	No. 19 through No. 25	$6d_b$		
180-degree hook	No. 10 through No. 16	$4d_b$	Greater of $4d_b$ and 65 mm	
	No. 19 through No. 25	$6d_b$		

^[1]A standard hook for stirrups, ties, and hoops includes the specific inside bend diameter and straight extension length. It shall be permitted to use a longer straight extension at the end of a hook. A longer extension shall not be considered to increase the anchorage capacity of the hook.

Standards of practice

Anchorage and lap lengths

The bond between the concrete and reinforcement determines the anchorage and lap lengths. Anchorage lengths, lap lengths should be determined by the Detailer / designer .

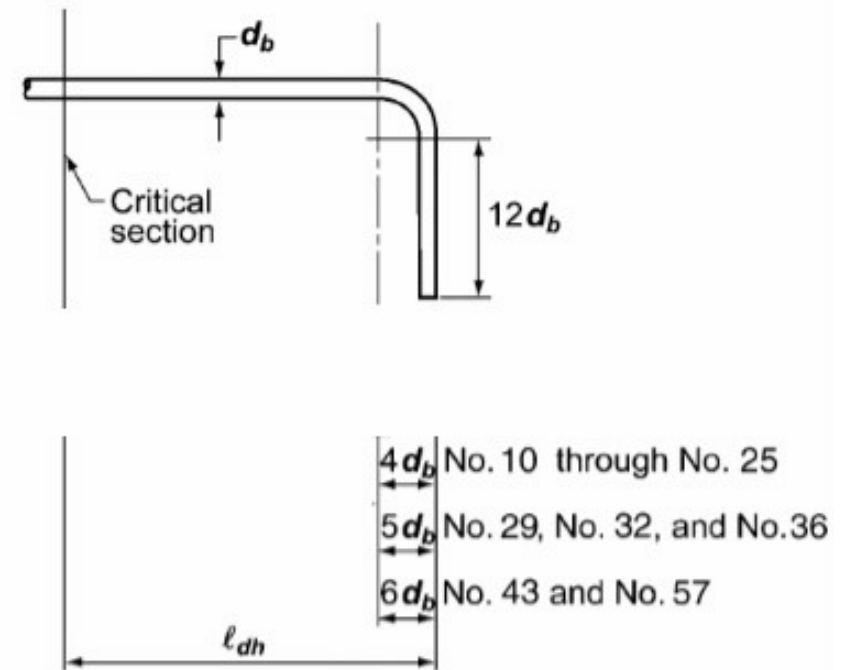
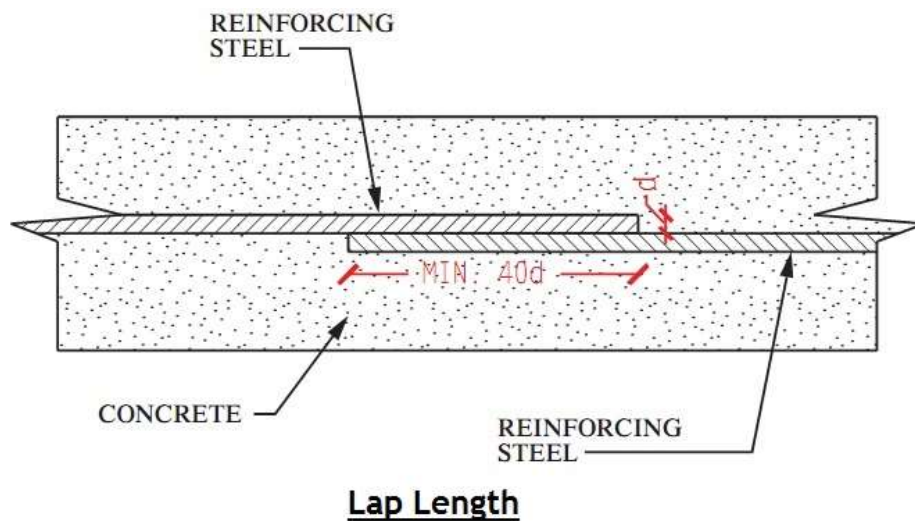

Anchorage (development) length

Standards of practice

Laps in reinforcement

Laps between bars should normally be staggered and not located in areas of high moments/forces (e.g. plastic hinges). They should normally be arranged symmetrically in any section. However, All secondary reinforcement may be lapped at the same location.

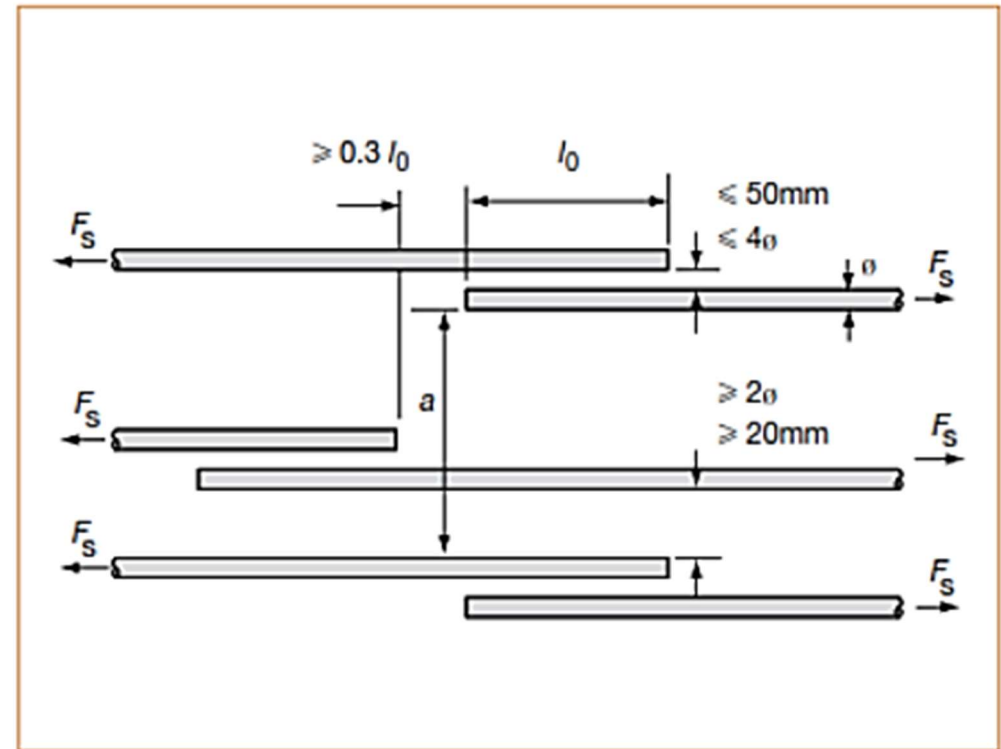

Mechanical couplers for bars

Where the reinforcement in a section is congested, mechanical couplers may be used to good effect. There are two distinct types of mechanical couplers : tension couplers and compression couplers. Several types of coupler are available for tensile and compressive bars. The following Figure shows typical examples of commonly available couplers.

Standards of practice



Note that Welding can be used to Connect bars. However, its seldom used in practice.

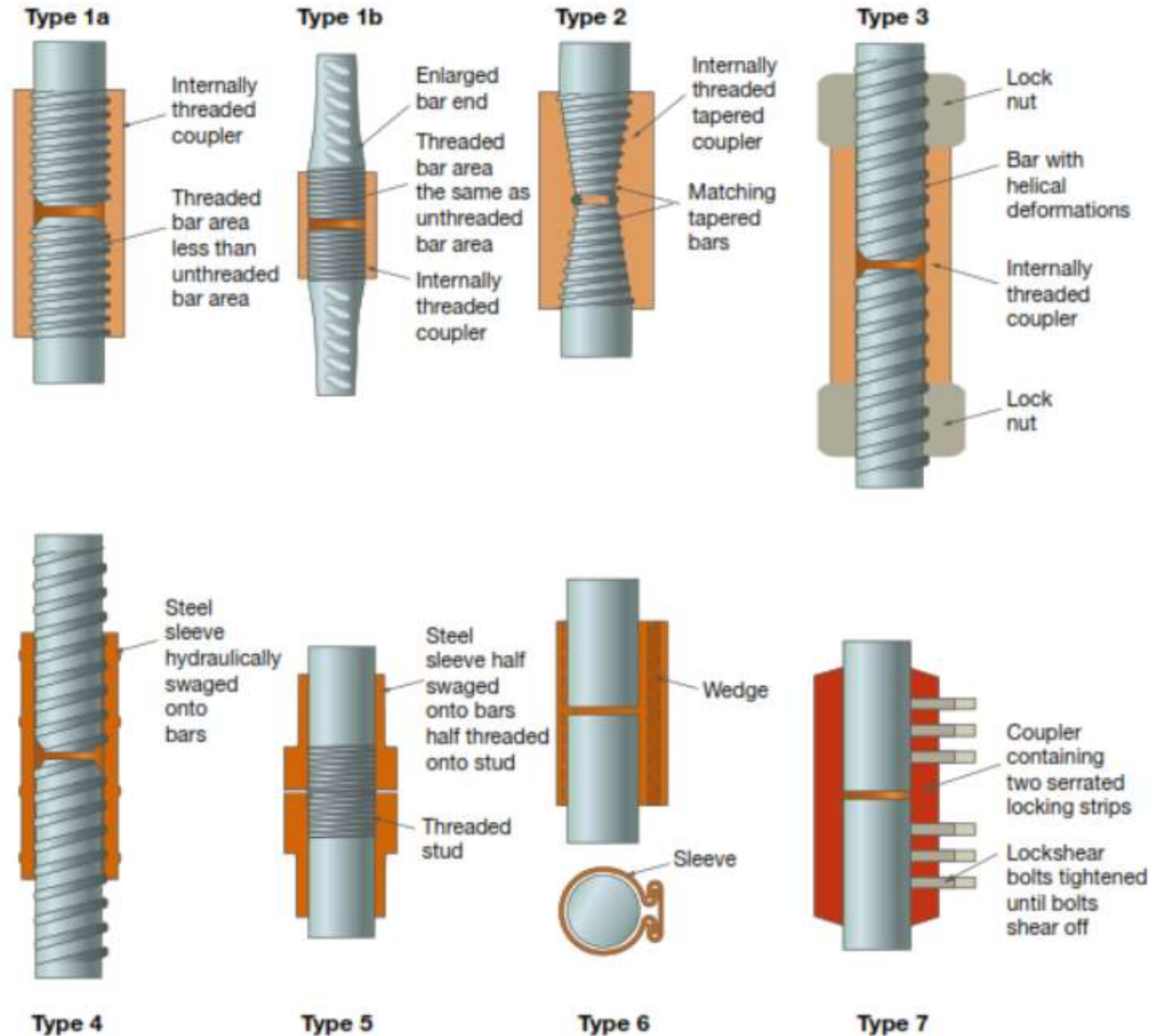

Standards of practice

Reinforcement Bar Symbols and notation

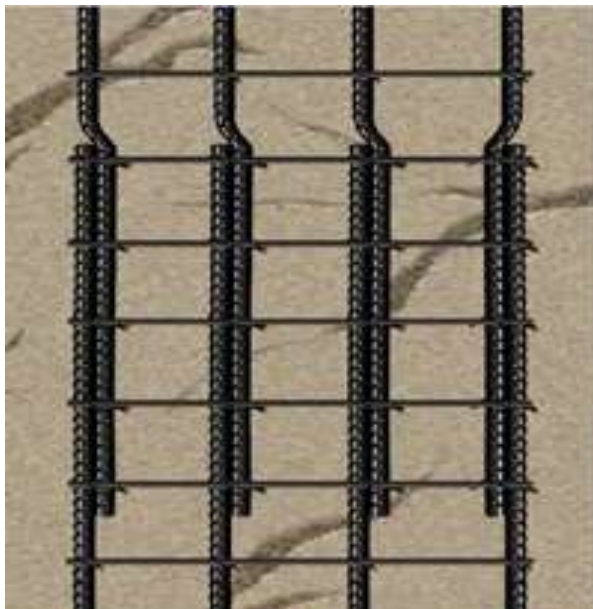

DESCRIPTION	EXAMPLE
Bar bent in elevation	
Bar bent toward observer	
Bar bent away from observer	
Hooked bar in elevation	
Hooked bar in plan	
Bar lapped inside	
Bars lapped (same plane)	
Bar lapped (cranked)	
Bar in section	1.5 x scale, where necessary

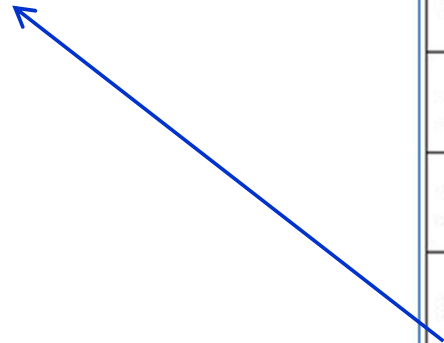

Standards of practice

Reinforcement notation

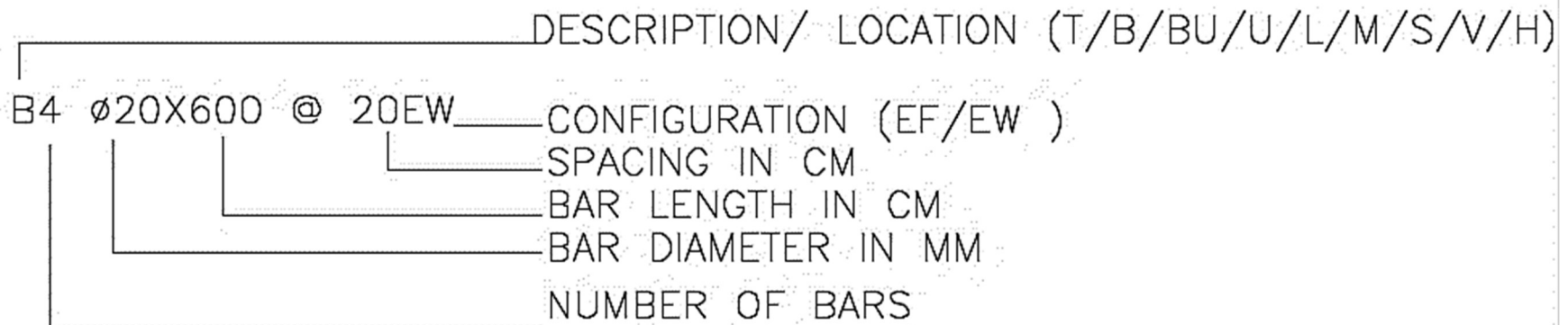

NOTATION OF REINFORCEMENT BARS

T	TOB BARS	M	LACER BARS AT SIDE FACES
B	BOTTOM BARS	S	STIRRUPS
BU	BENT UP BARS	V	VIRTICAL BARS
U	U SHAPED BARS	H	HORIZONTAL BARS
L	L SHAPED BARS	EF/EW	EACH FACE/ EACH WAY