

Joints Details

Chapter 3
Section

3-7

Beam - column Joints

- In RC buildings, portions of columns that are common to beams at their intersections are called beam-column joints.
- The function of a beam-column joint in a frame is to transfer the loads and moments at the ends of the beams into the columns.
- This particular junction of structural members is one of the most vulnerable, in terms of failure tendency during earthquakes.
- Studies showed that sound detailing of the joint reinforcement enhances the property of the joint significantly.



Type of joints

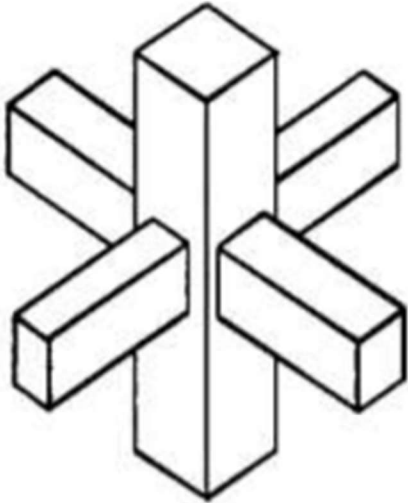

a) Interior

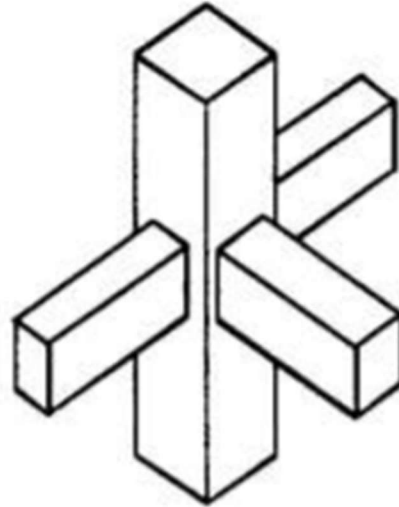

b) Exterior

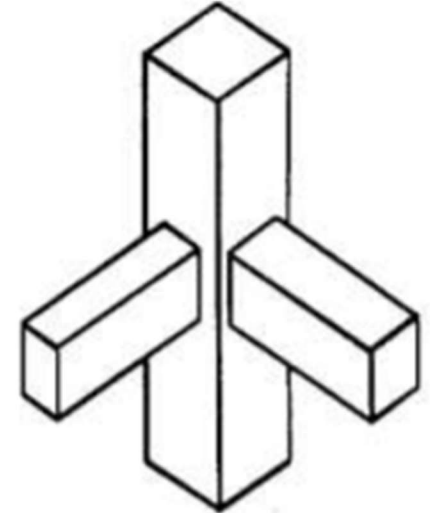

c) Corner

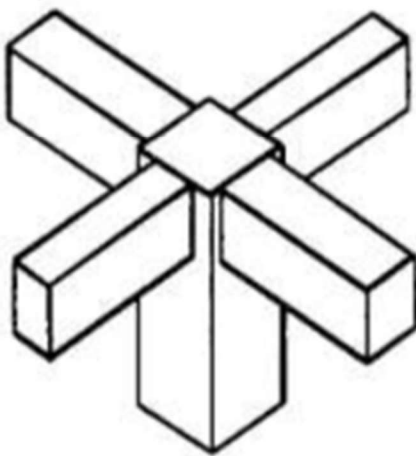

d) "Roof"-interior

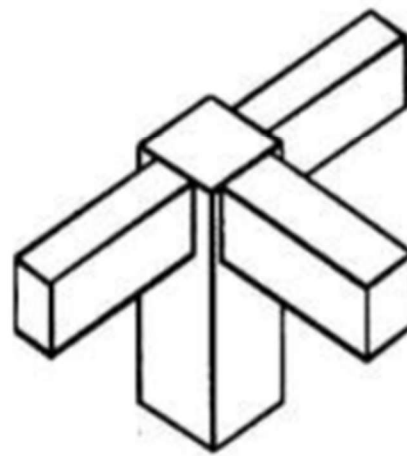

e) "Roof"-exterior

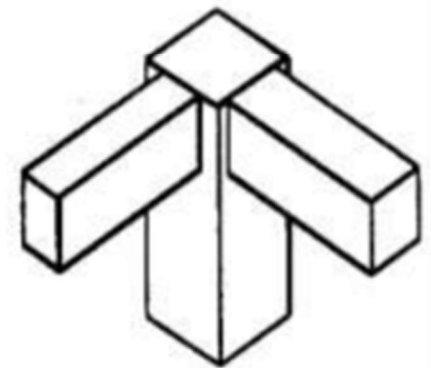

f) "Roof"-corner

Design and detailing notes

1. Designer to ensure that the joint will work in reality as it has been modeled in the analysis stage. This include the correct proportion of joint dimension to ensure full transition of loads between members

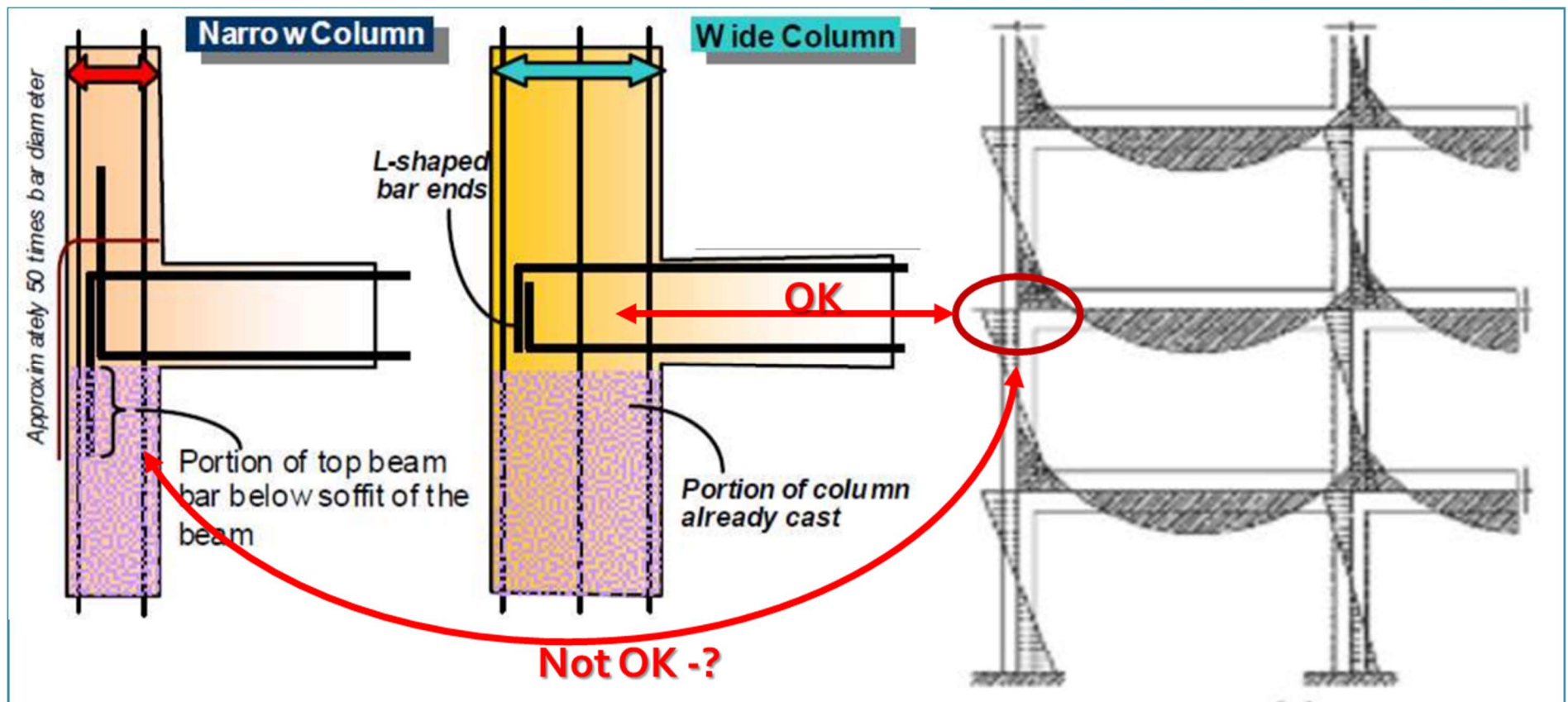

Design and detailing notes

2. Designer to ensure that the joint can carry the applied stress safely. The joint is usually subjected to horizontal and vertical shear which leads to diagonal compression and tension struts. The latter will cause diagonal cracks in the joint and may lead to joint failure. In this case designer needs to introduce joint reinforcement (Ties) that cross the cracks and maintain joint integrity.

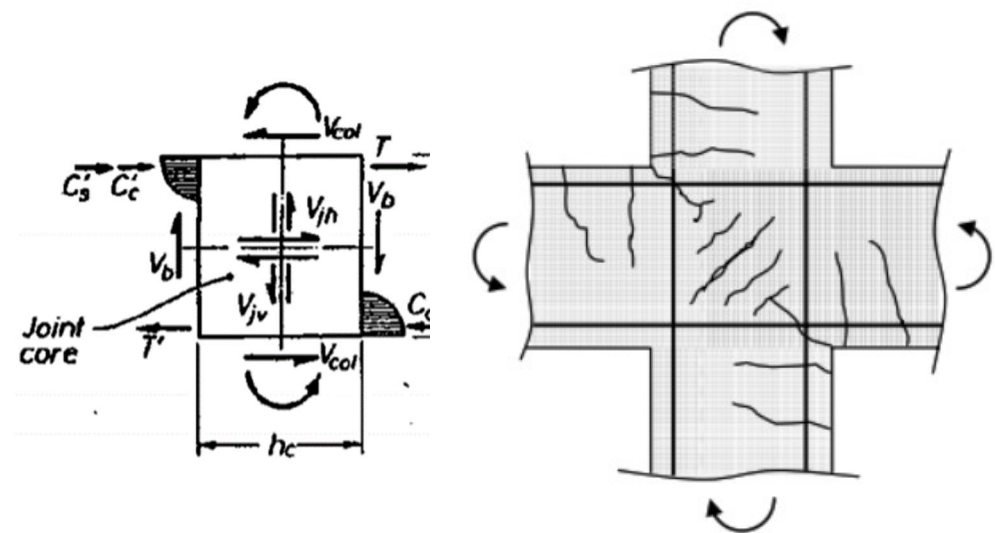
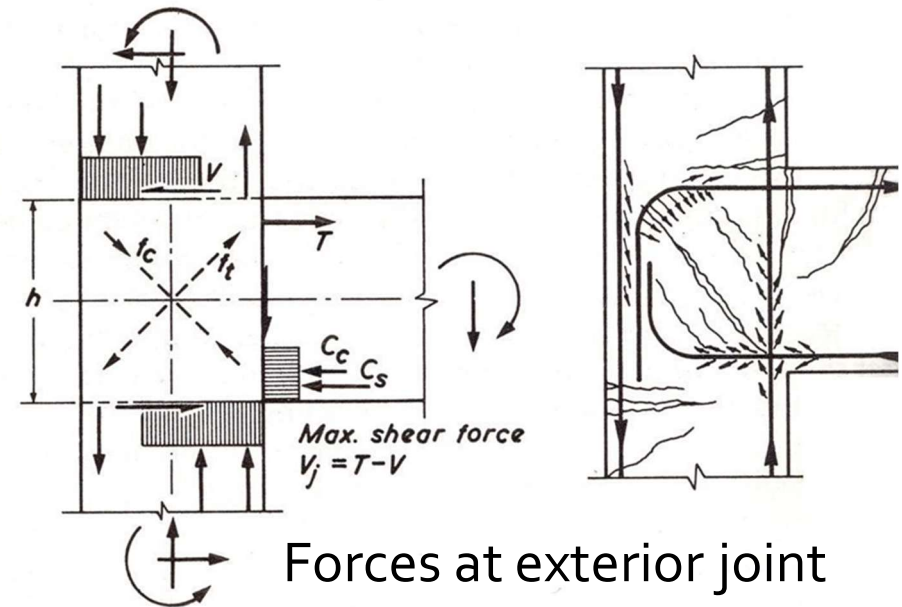

Forces at interior joint

Joint Reinforcement

Intermediate corner joint reinforcement

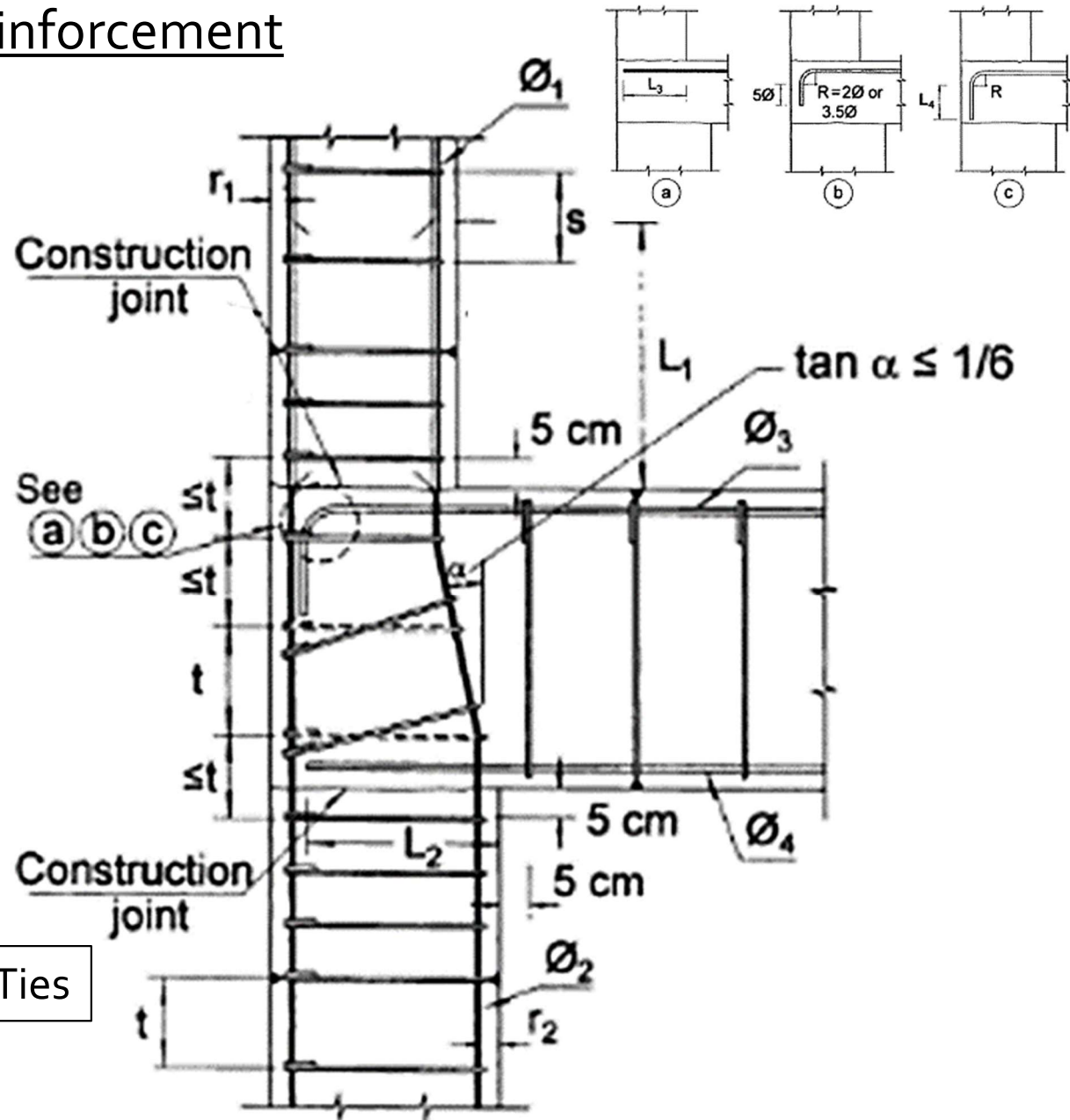
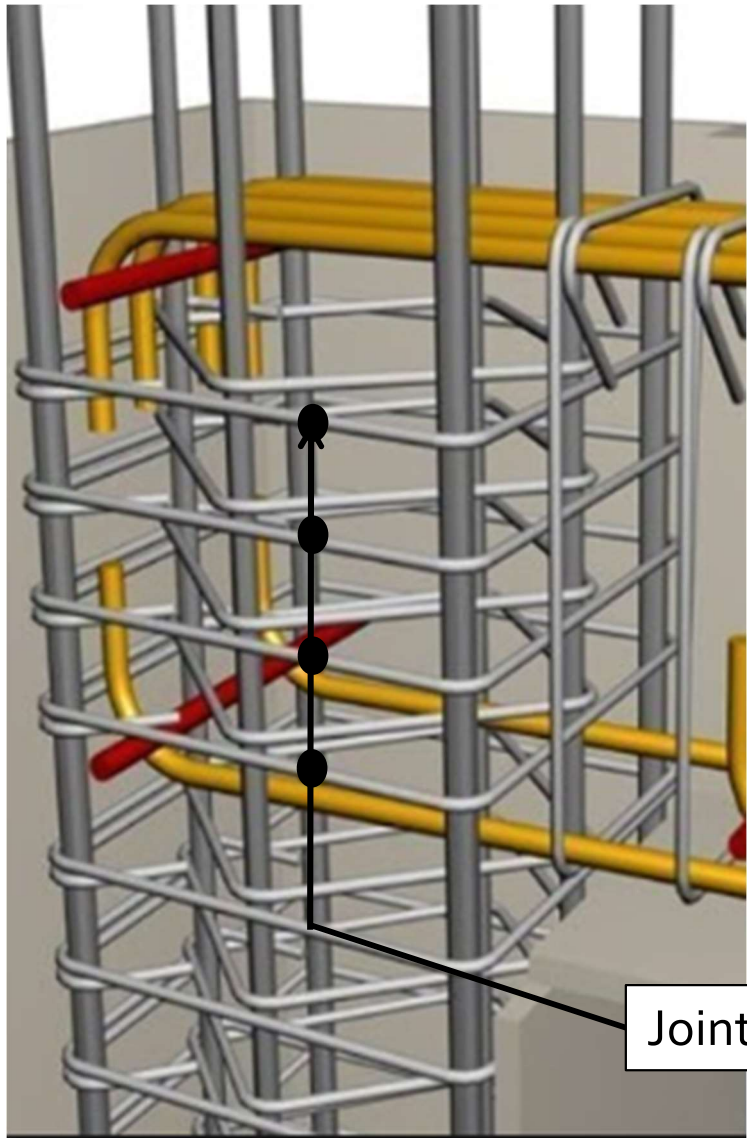

Joint Reinforcement

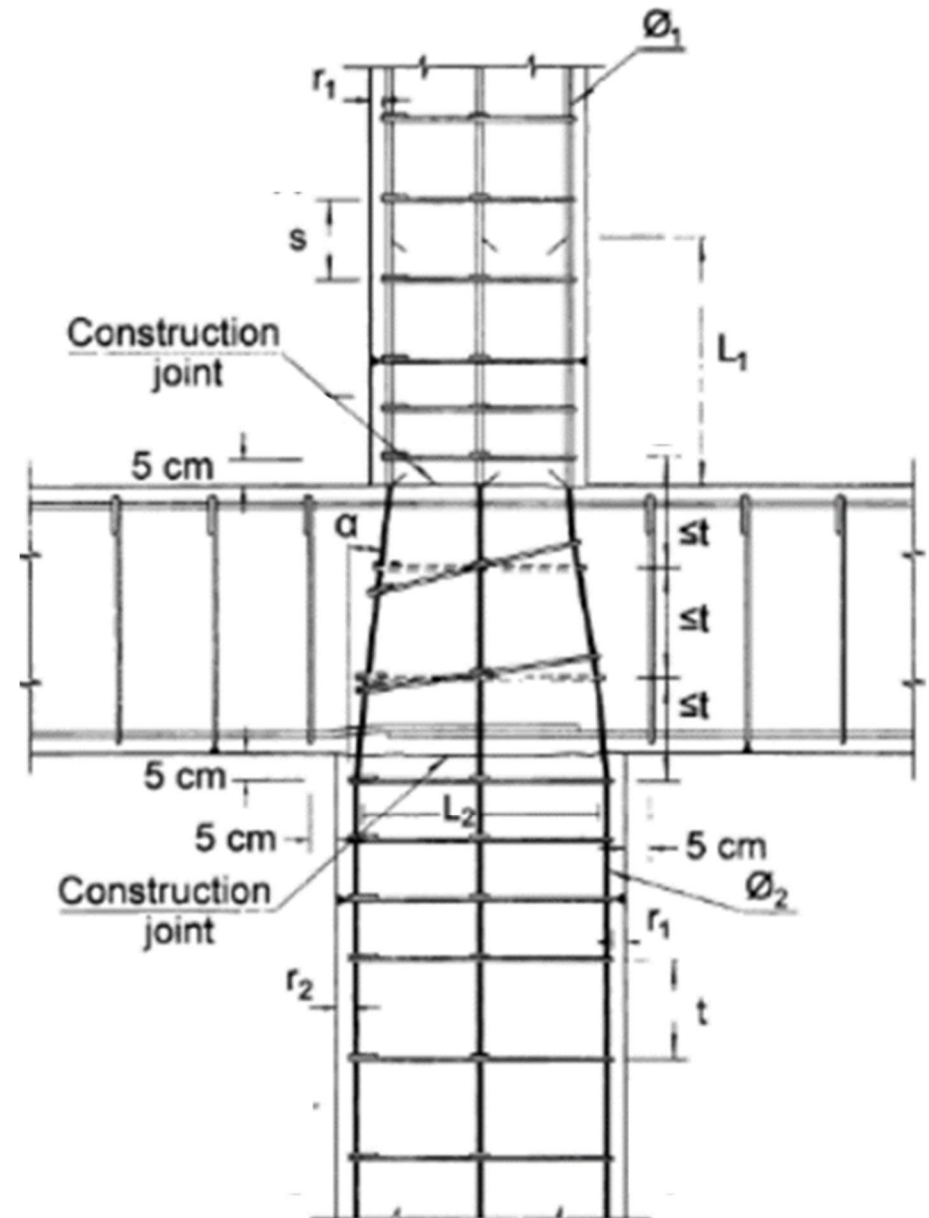
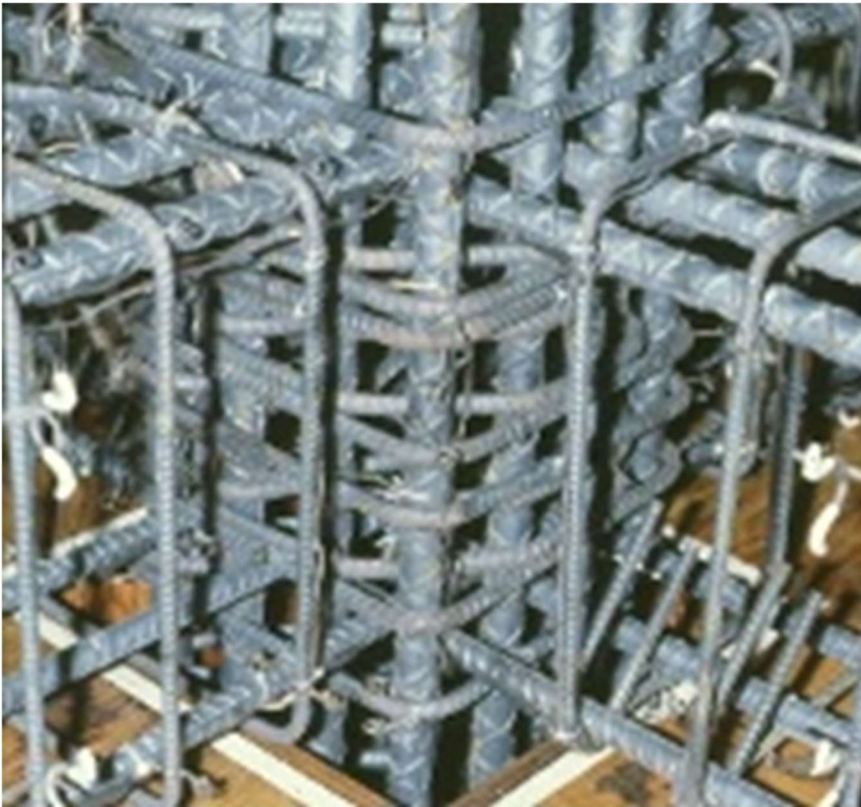

Inside joint in intermediate floor

Joint Reinforcement

Knee joint

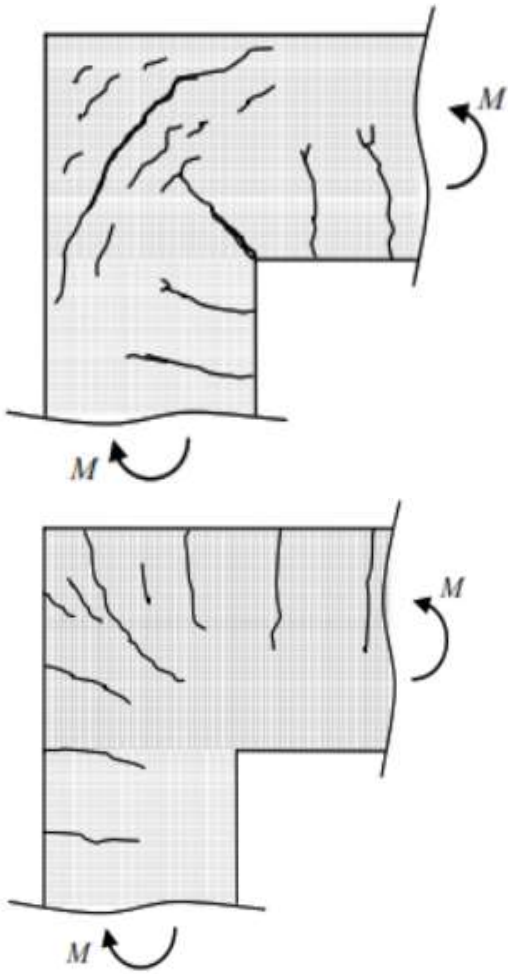

Crack pattern

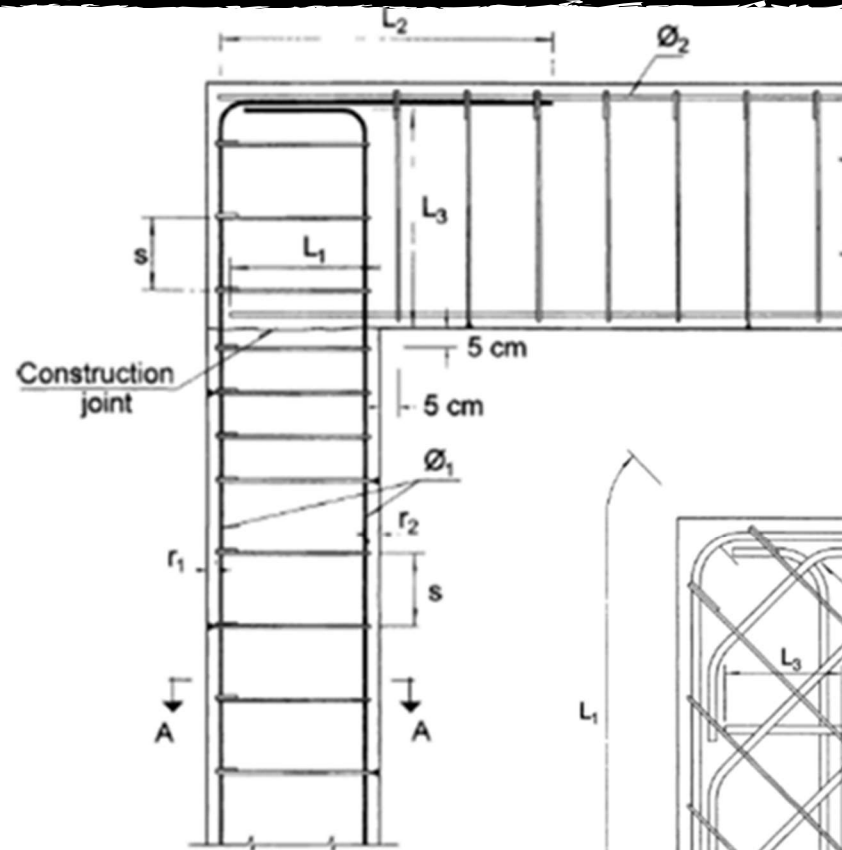

Corner joint on last storey

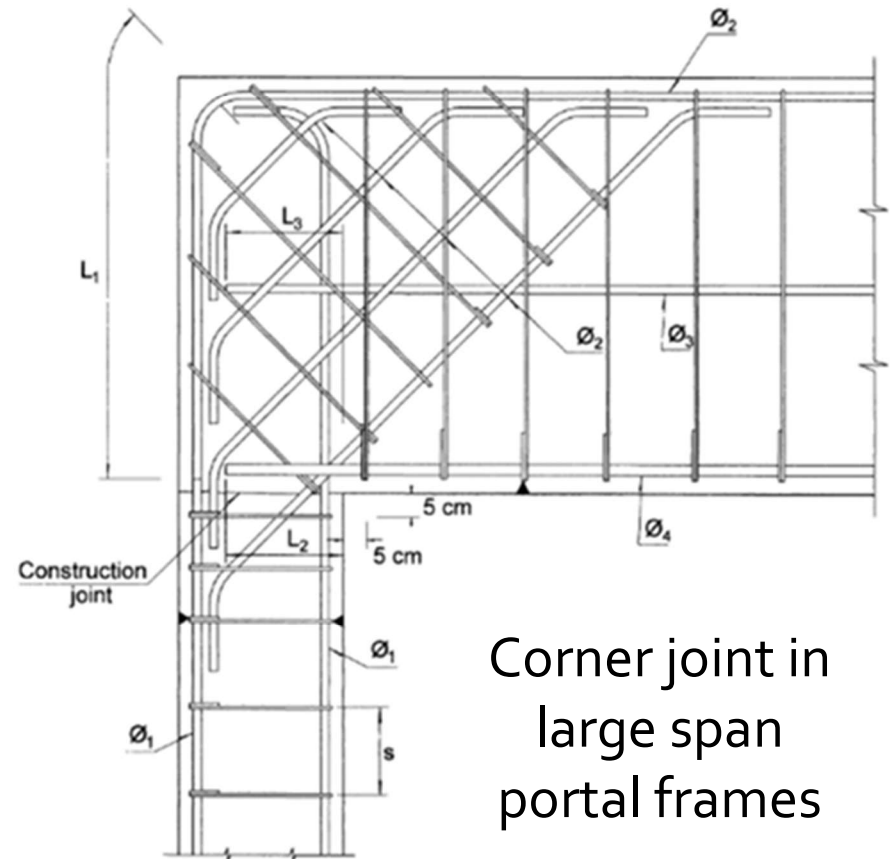

Corner joint in large span portal frames

Earthquake Details

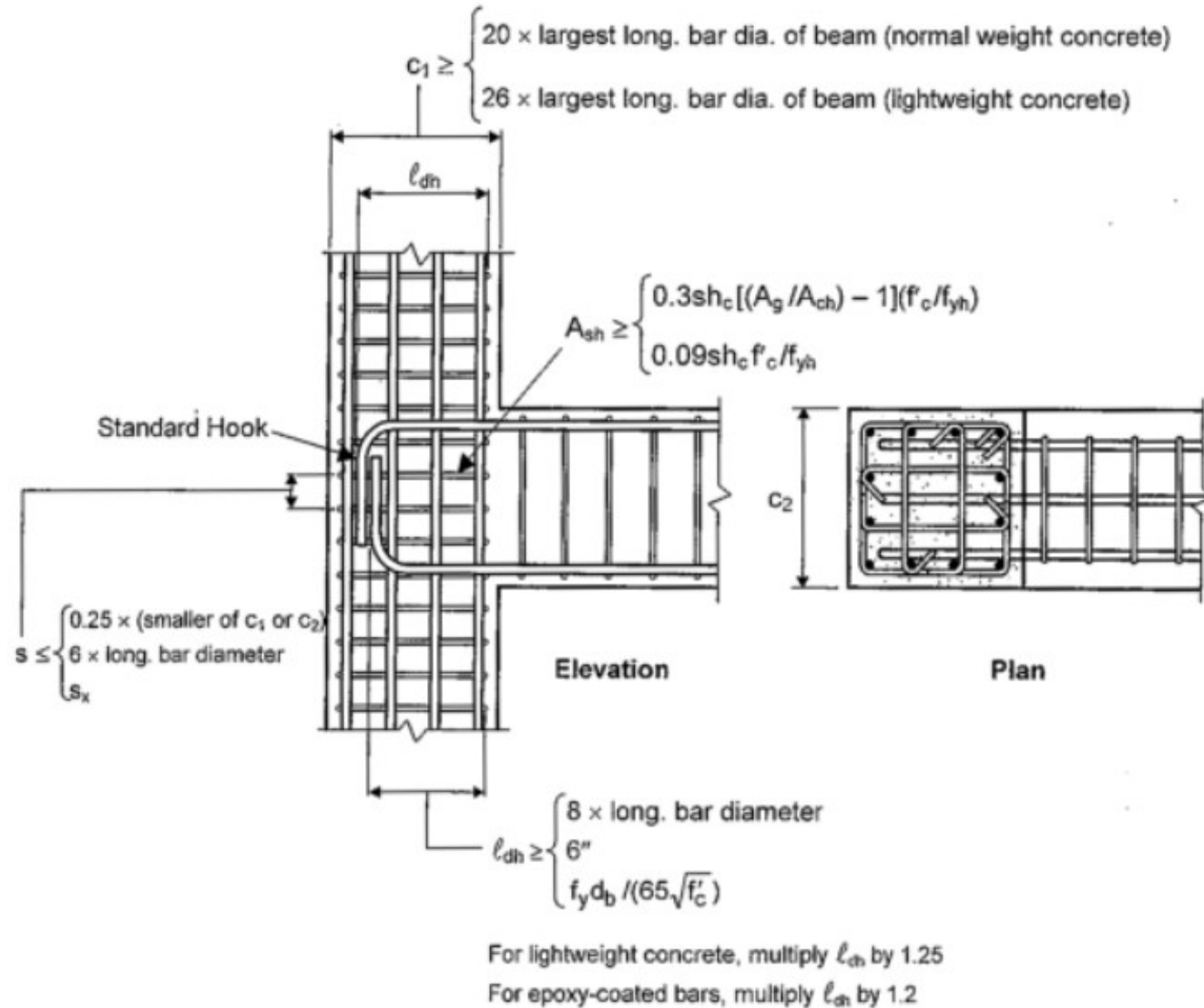

General Requirements and Transverse Reinforcement Requirements for Joints not Confined by Structural Members

Earthquake Details

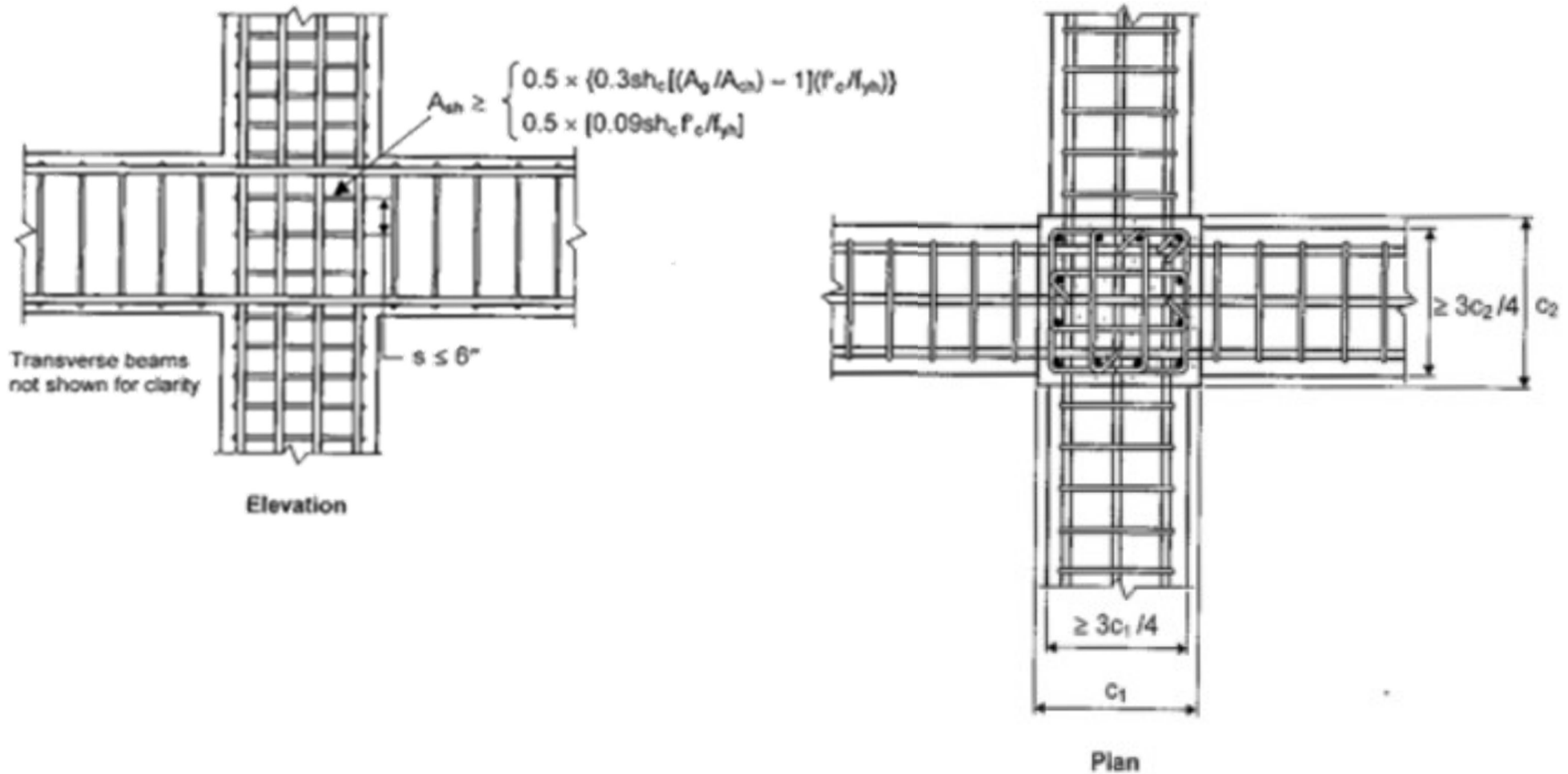

Transverse Reinforcement Requirements for Joints Confined by Structural Members