

Birzeit University
Faculty of Engineering
Department of Civil and Environmental Engineering

ENCE 3331, Structural Analysis I

Homework 5

Due Tuesday, April 21st, 2020.

There will be a quiz on this HW material on the same day

Problem 1:

The following truss is made of steel ($\alpha = 12 \times 10^{-6} \frac{1}{C}$). Using virtual work method, determine the vertical deflection of joint C, and G due to the following:

1. The concentrated forces at G and H.
2. If the truss was designed and fabricated at 20°C and the temperature decreased later to -20°C, but only members AF and FG were affected by this change.
3. If members HD, and FB were fabricated 5 cm shorter than designed.
4. Due to conditions 1 & 2.
5. Due to conditions 1 & 3.
6. Due to conditions 1, 2, and 3 simultaneously.

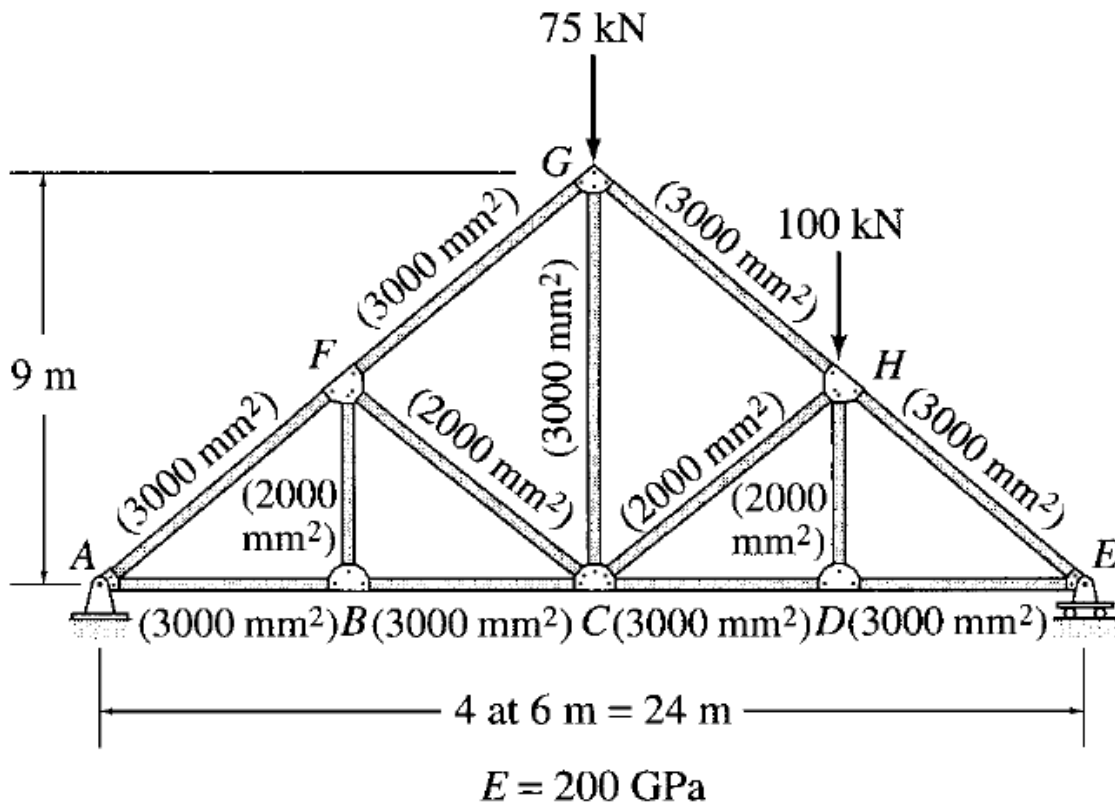

Problem 2:

The given truss is made of steel. Determine the minimum required cross-sectional area for each member if the maximum allowable drift (horizontal sway) is 3 cm. Use virtual work method.

(assume all members have the same cross-sectional area)

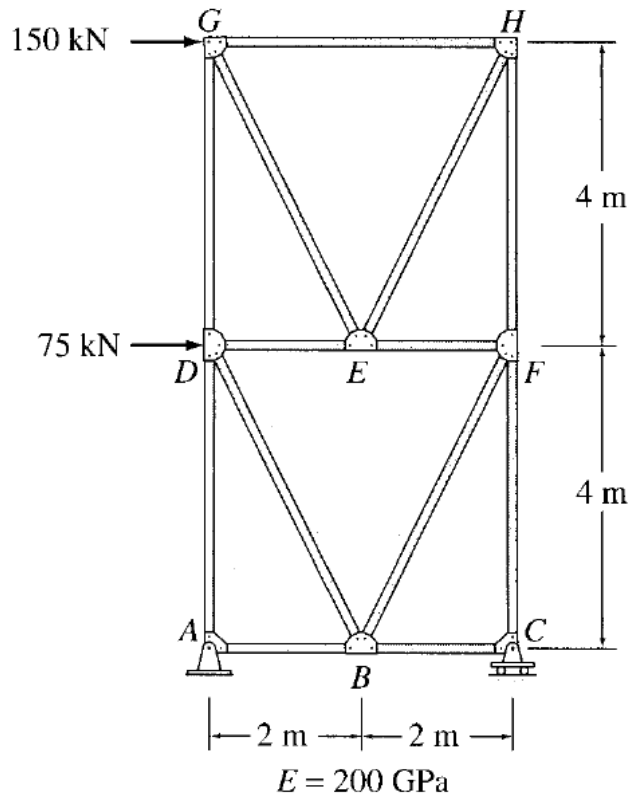

Problem 3:

The given truss members have the same cross-sectional area and are made from the same material, Determine:

1. The vertical deflection of point D
2. The horizontal displacement of joint F
3. The rotation of member CD.

