

Seismic design of RC buildings following ACI 318-14

Design outline

Special shear wall system:

Minimum reinforcement ratios for longitudinal and horizontal reinforcement

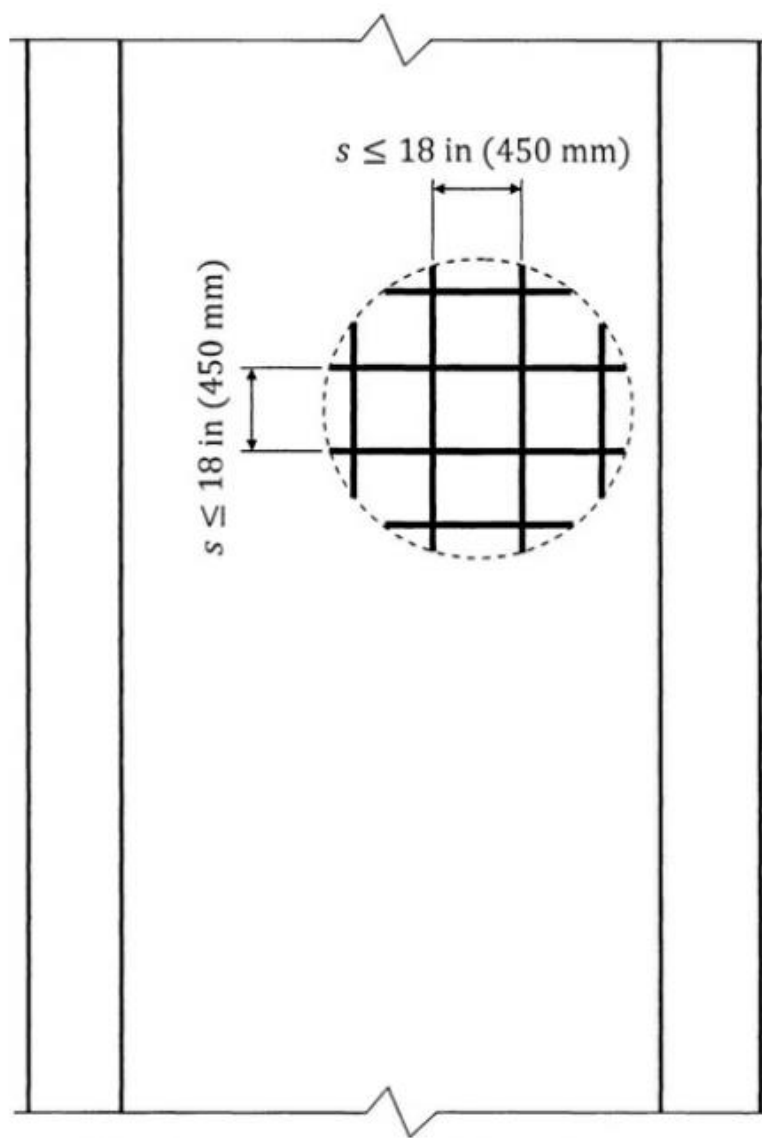

All other reinforcement not shown for clarity

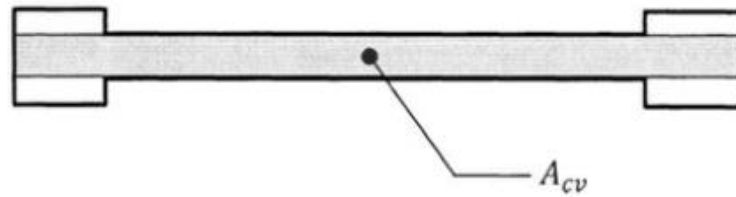

- For $V_u \leq A_{cv}\lambda\sqrt{f'_c}$ [In SI: $V_u \leq 0.083A_{cv}\lambda\sqrt{f'_c}$]:
 $\rho_\ell \geq 0.0012$ for No. 5 (No. 16) bars and smaller
 ≥ 0.0015 for No. 6 (No. 19) bars and larger
 $\rho_t \geq 0.0020$ for No. 5 (No. 16) bars and smaller
 ≥ 0.0025 for No. 6 (No. 19) bars and larger
- For $V_u > A_{cv}\lambda\sqrt{f'_c}$ [In SI: $V_u > 0.083A_{cv}\lambda\sqrt{f'_c}$]:
 $\rho_\ell \geq 0.0025$
 $\rho_t \geq 0.0025$
- For $V_u > 2A_{cv}\lambda\sqrt{f'_c}$ [In SI: $V_u > 0.17A_{cv}\lambda\sqrt{f'_c}$]
or $h_w/\ell_w \geq 2.0$:
Provide at least two curtains of reinforcement

Special shear wall systems

- Shear strength of special shear walls, categorized for tall and squat walls

Shear Strength	<p>The nominal shear strength shall not exceed the following:</p> $V_n = A_{cv}(\alpha_c \lambda \sqrt{f'_c} + \rho_t f_y)$ <p>where $\alpha_c = 3.0$ for $h_w/\ell_w \leq 1.5$ [In SI: $\alpha_c = 0.25$] $\alpha_c = 2.0$ for $h_w/\ell_w \geq 2.0$ [In SI: $\alpha_c = 0.17$] α_c varies linearly between 3.0 [0.25] and 2.0 [0.17] for h_w/ℓ_w between 1.5 and 2.0</p>	18.10.4.1
	<p>The value of h_w/ℓ_w to be used when determining V_n by ACI 18.10.4.1 for segments of a wall shall be the greater of the ratios for the entire wall and the segment of the wall considered.</p>	18.10.4.2
	<p>Walls shall have distributed shear reinforcement in two orthogonal directions in the plane of the wall. Reinforcement ratio ρ_ℓ must be greater than or equal to reinforcement ratio ρ_t where $h_w/\ell_w \leq 2.0$.</p>	18.10.4.3

Special shear wall systems: design for flexure and axial forces

- Shear walls are designed like a column element, an interaction diagram can be constructed for a wall using strain compatibility analysis based on the reinforcement that is in the section
- Factored axial force and bending moment points must fall within or on the design strength interaction diagram
- Walls with flanges, e.g. walls encasing the elevator shaft, a portion of the flange is considered to be effective in resisting the combined effect of axial forces and bending moments

Special shear wall systems: design for flexure and axial forces

Effective width of wall flanges

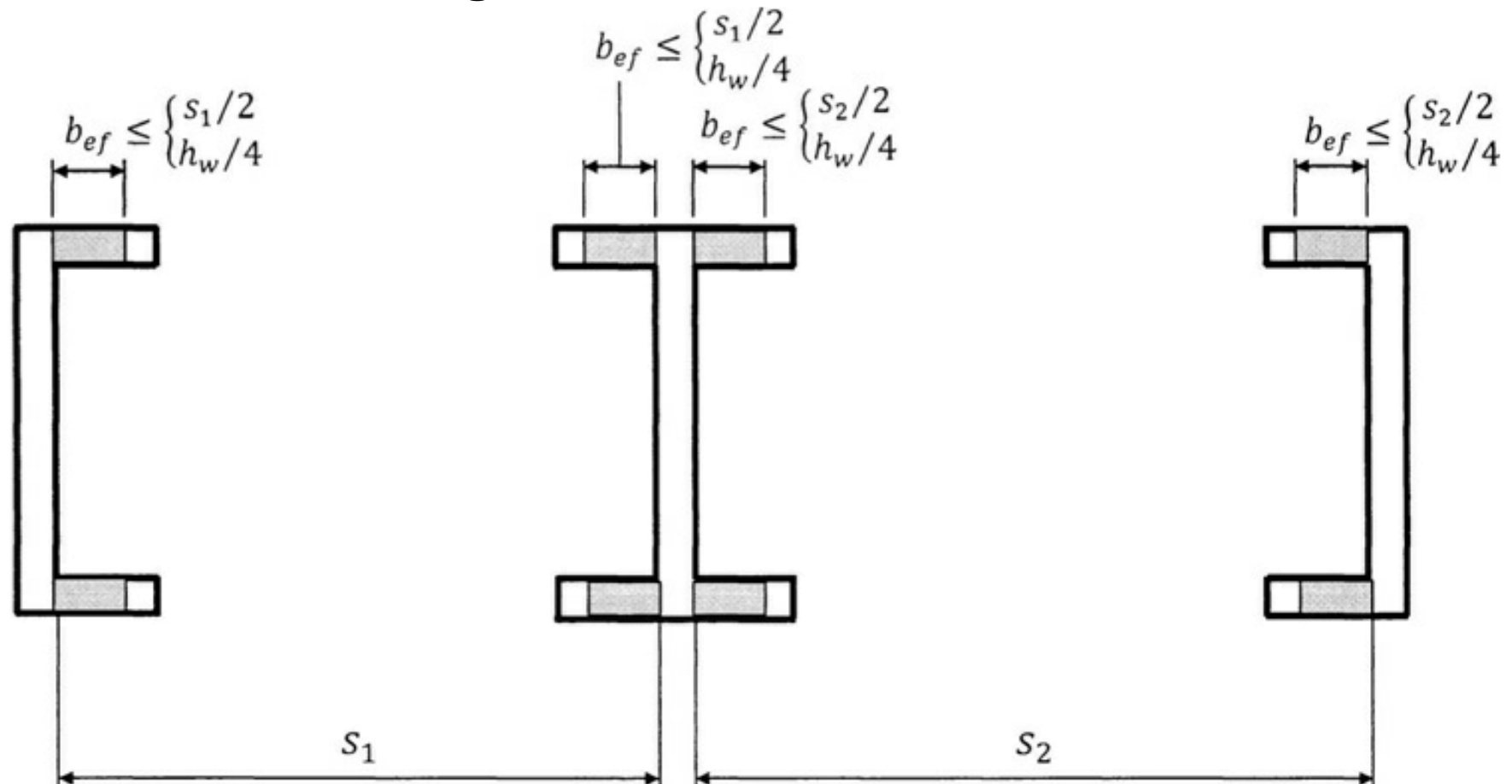

Special shear walls:
Boundary elements

what is the force that boundary element are designed to resist?

There are two approaches to decide when a boundary element is needed :

Approach I: displacement-based

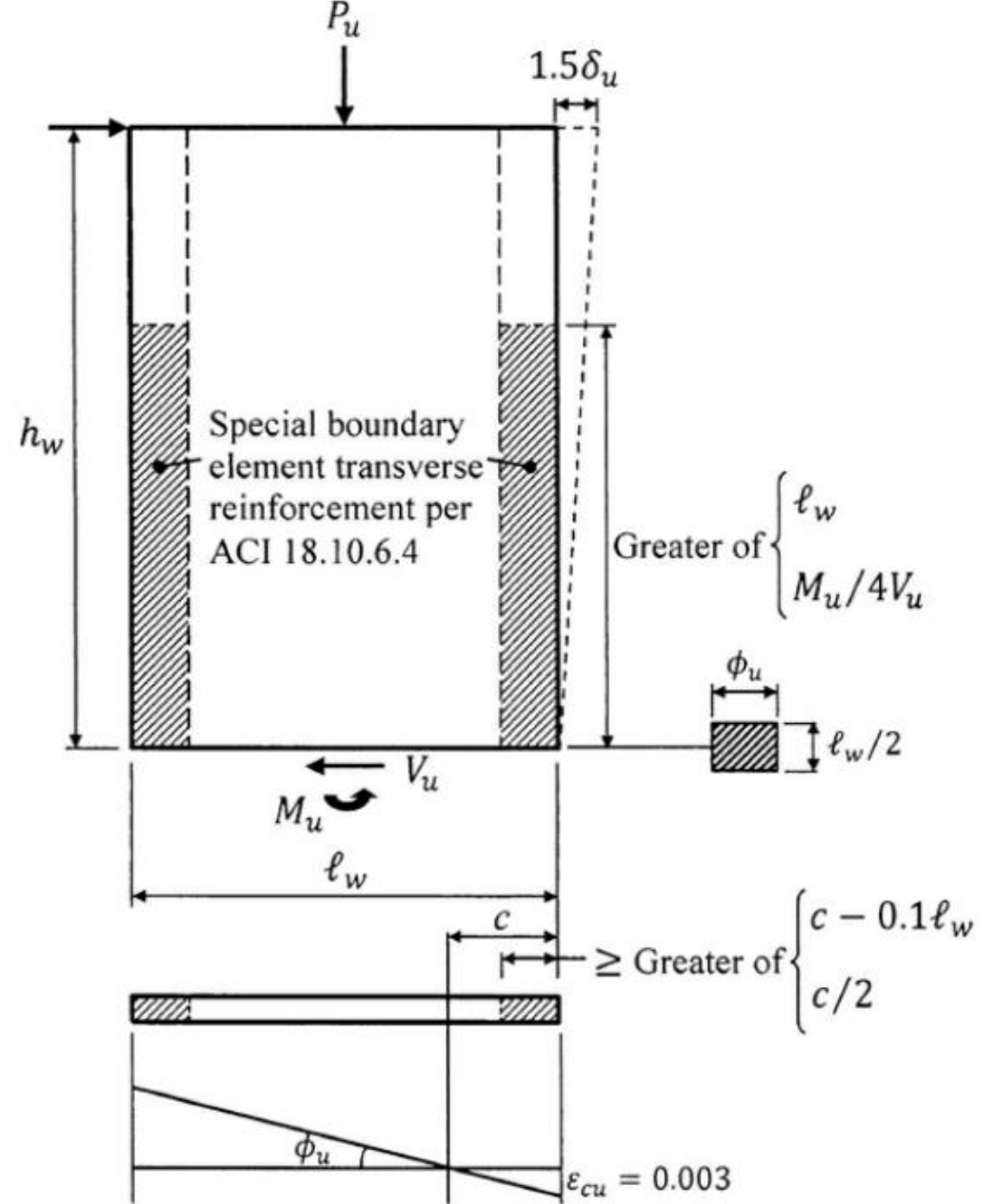

Special boundary elements required where $c \geq \frac{\ell_w}{600(1.5\delta_u/h_w)}$

Special shear walls: boundary elements

Approach II: Compressive stress approach

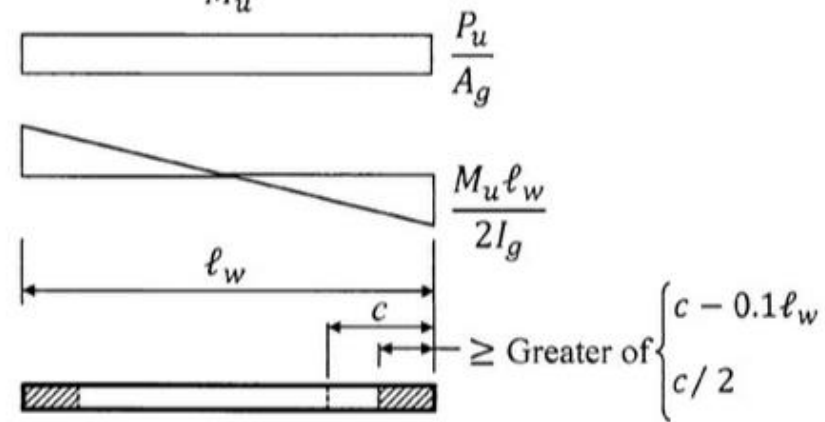
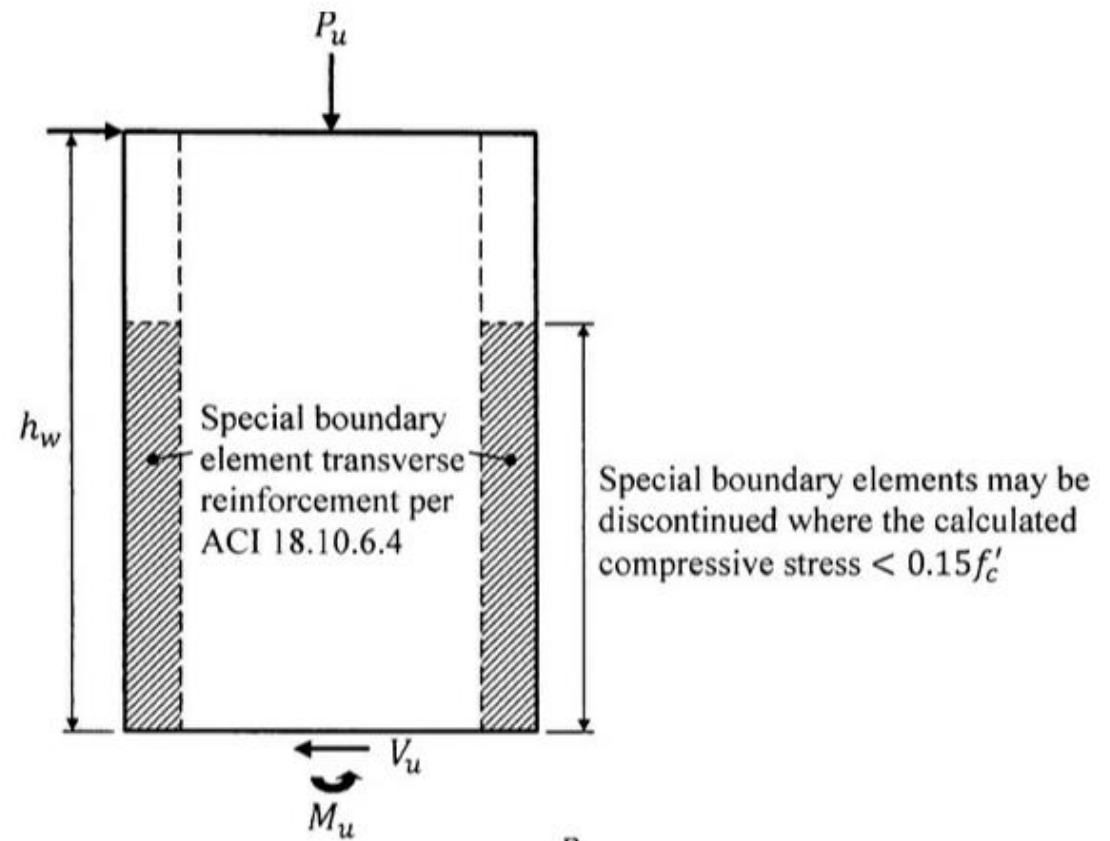

Special boundary elements required where $\frac{P_u}{A_g} + \frac{M_u \ell_w}{2I_g} > 0.2f'_c$

Special shear walls: detailing of boundary elements

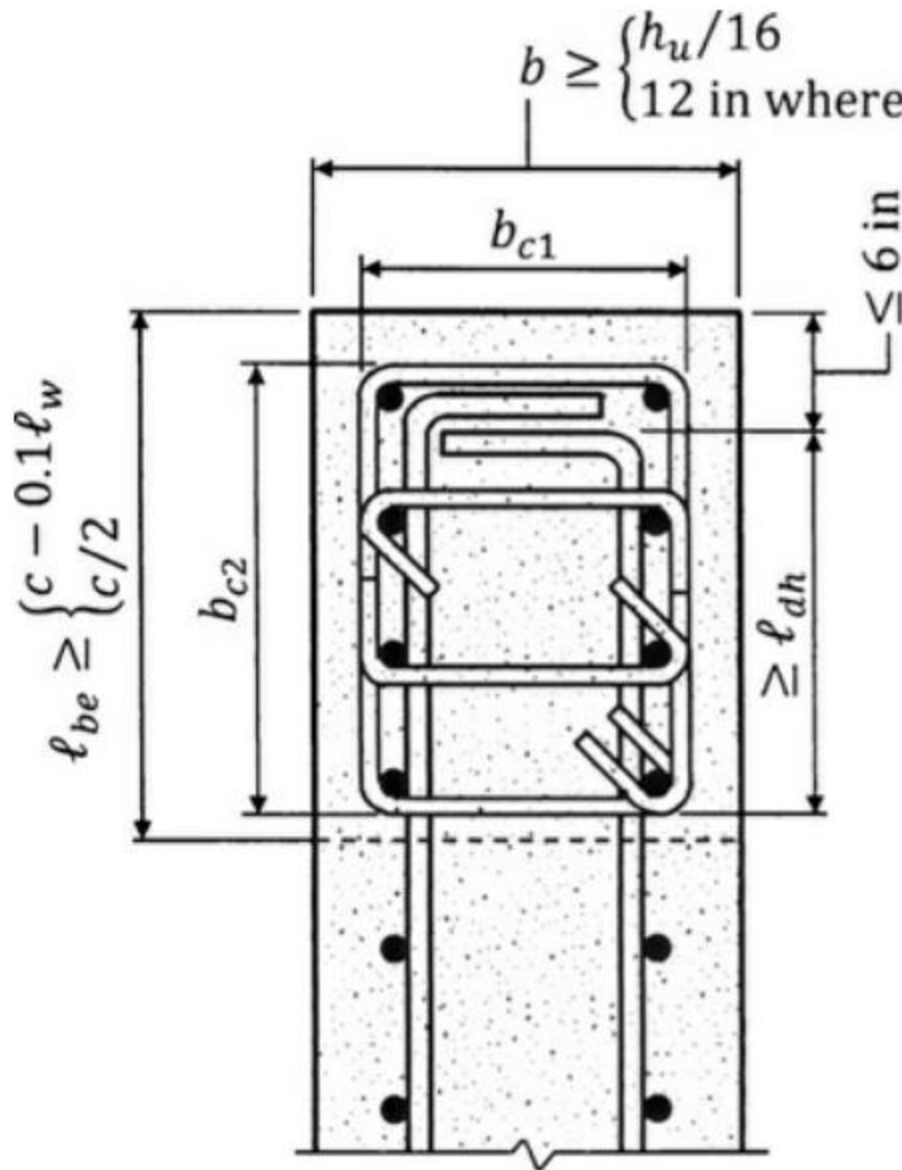

Special shear walls: detailing of boundary elements

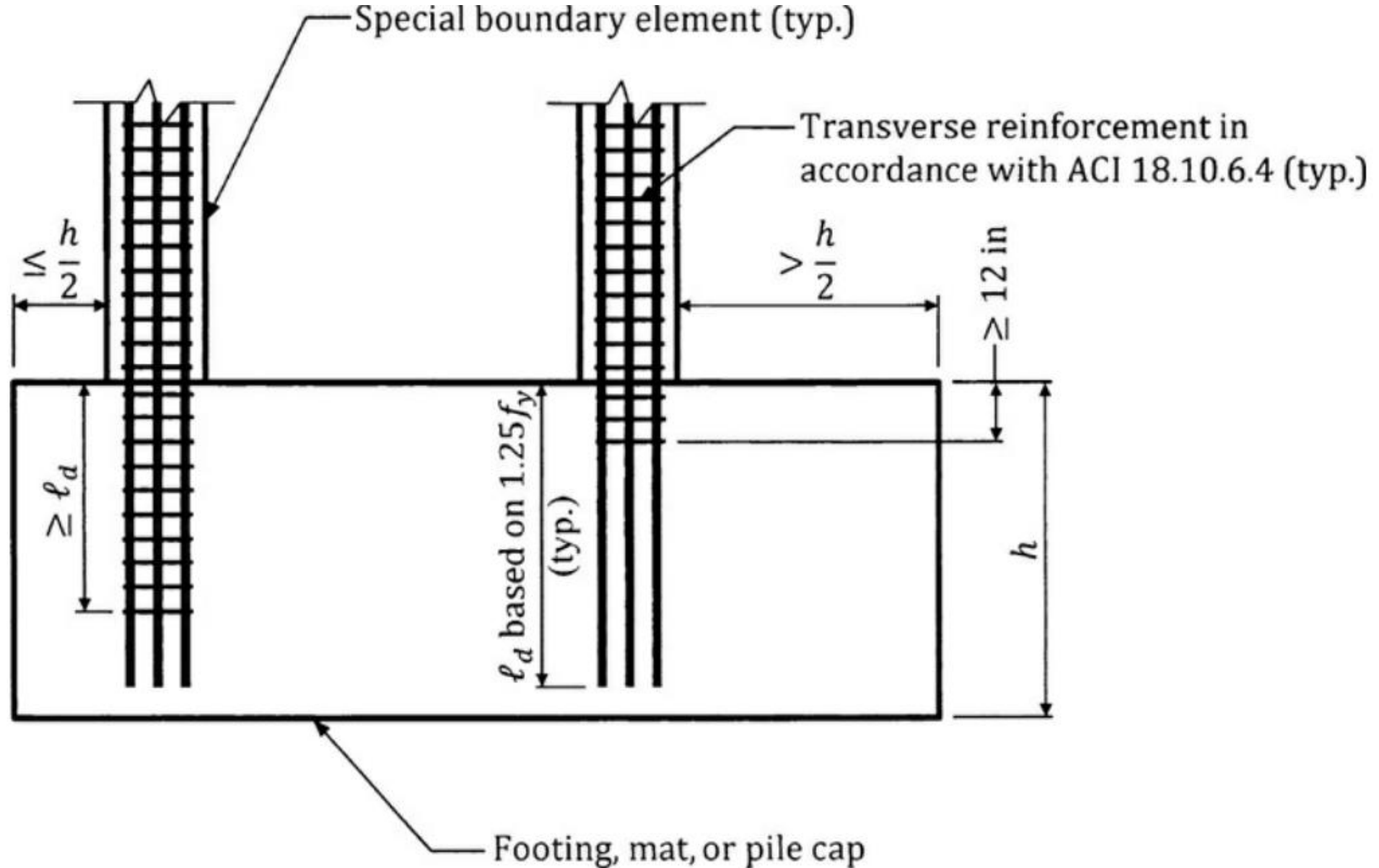

Coupling beams:

Coupling beams are beams that connect two structural walls together and are typically aligned vertically above openings in the wall over its height

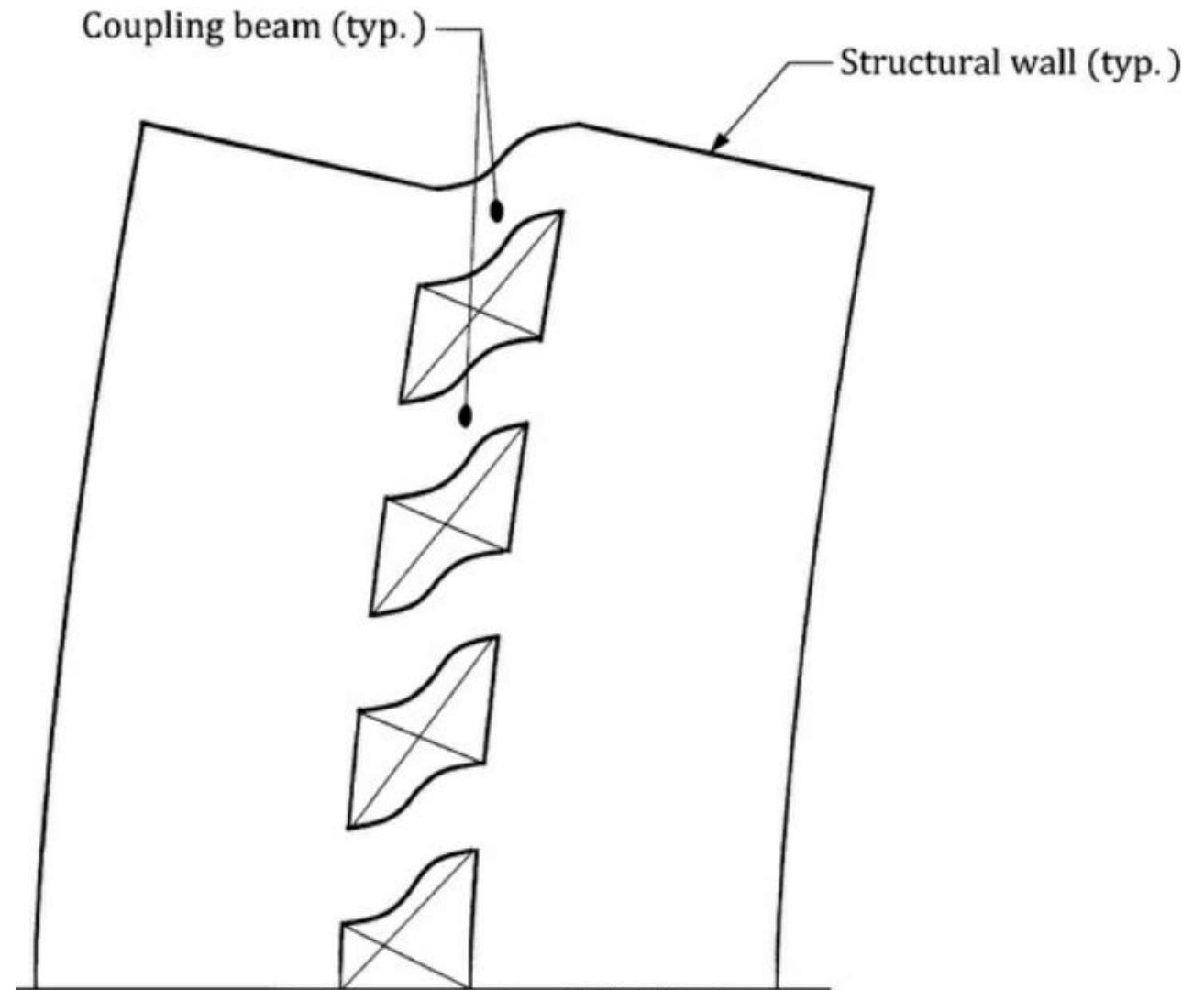

Detail of a coupling beam

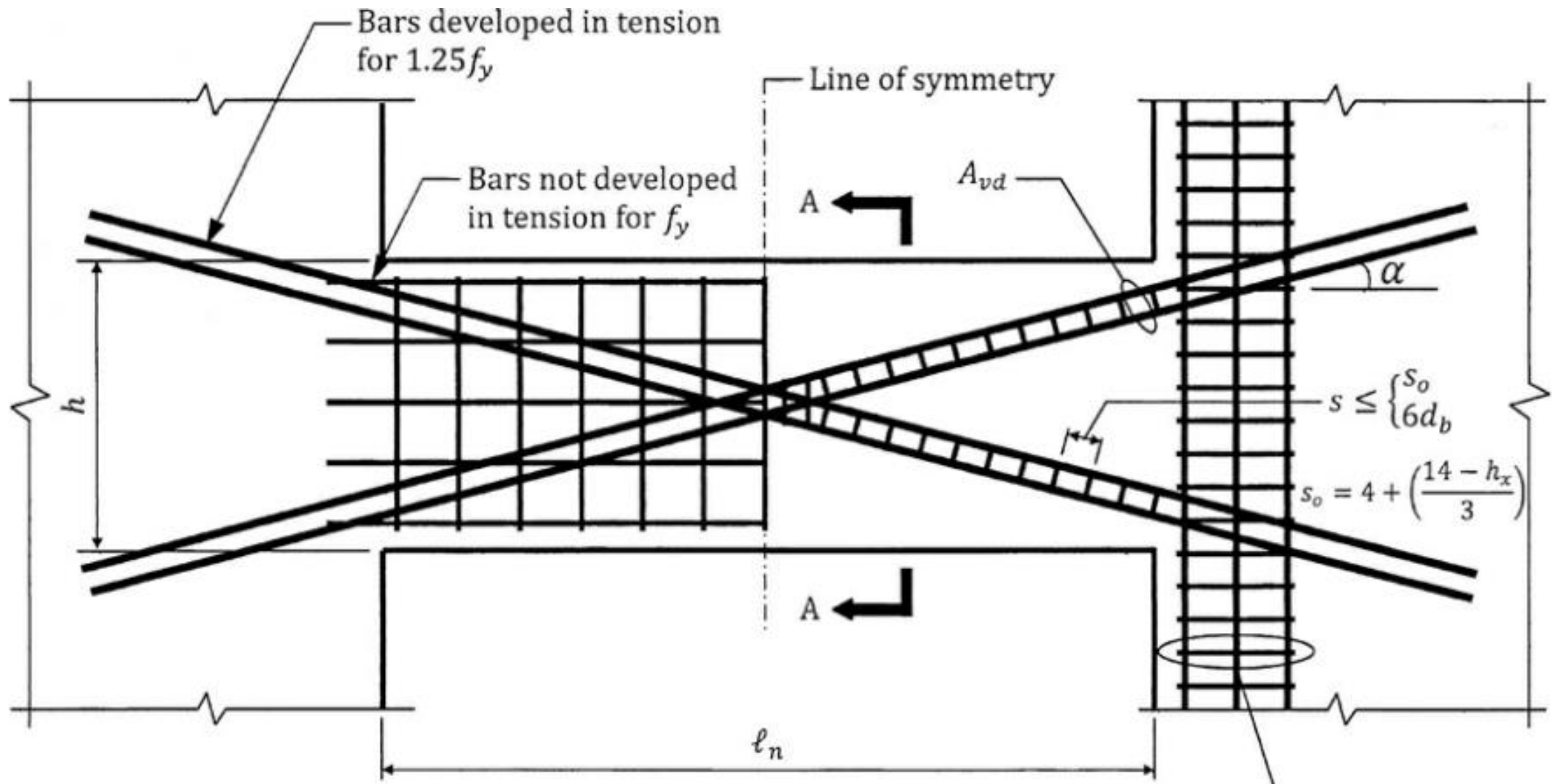

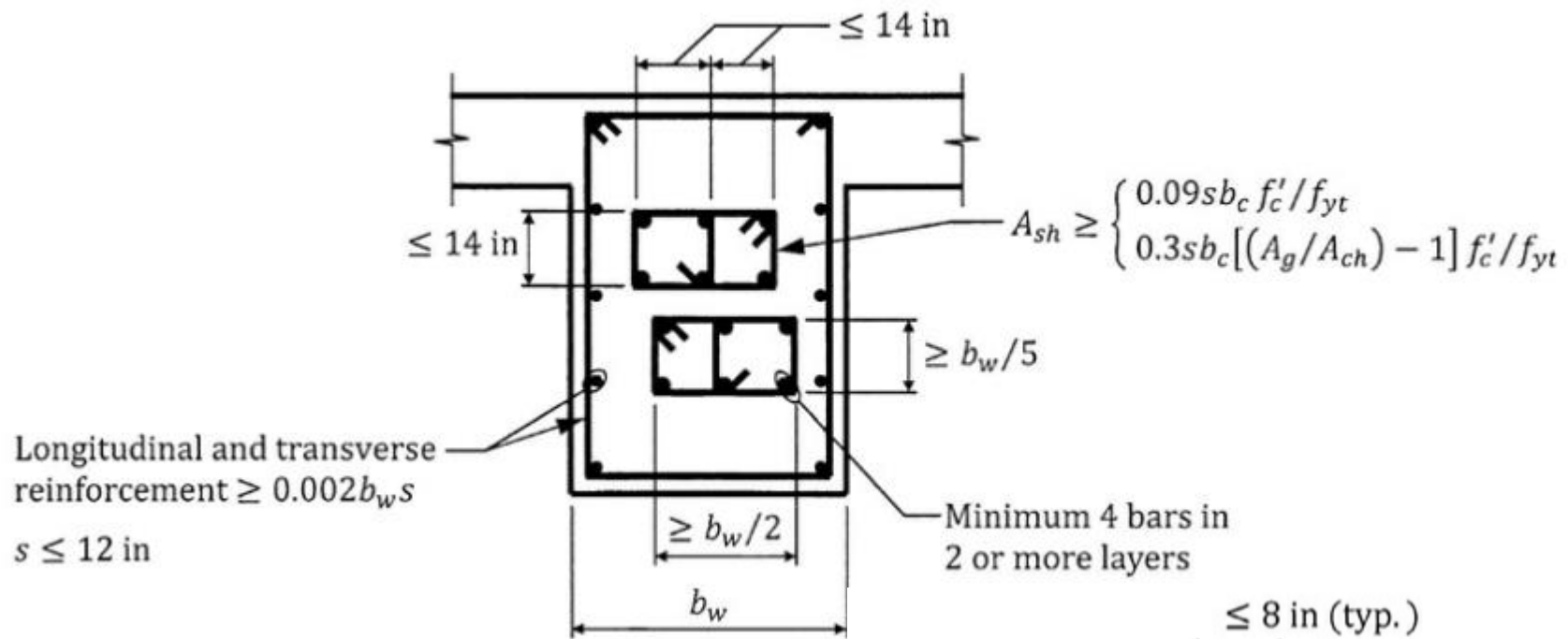

- Typical cross-section a coupling beam

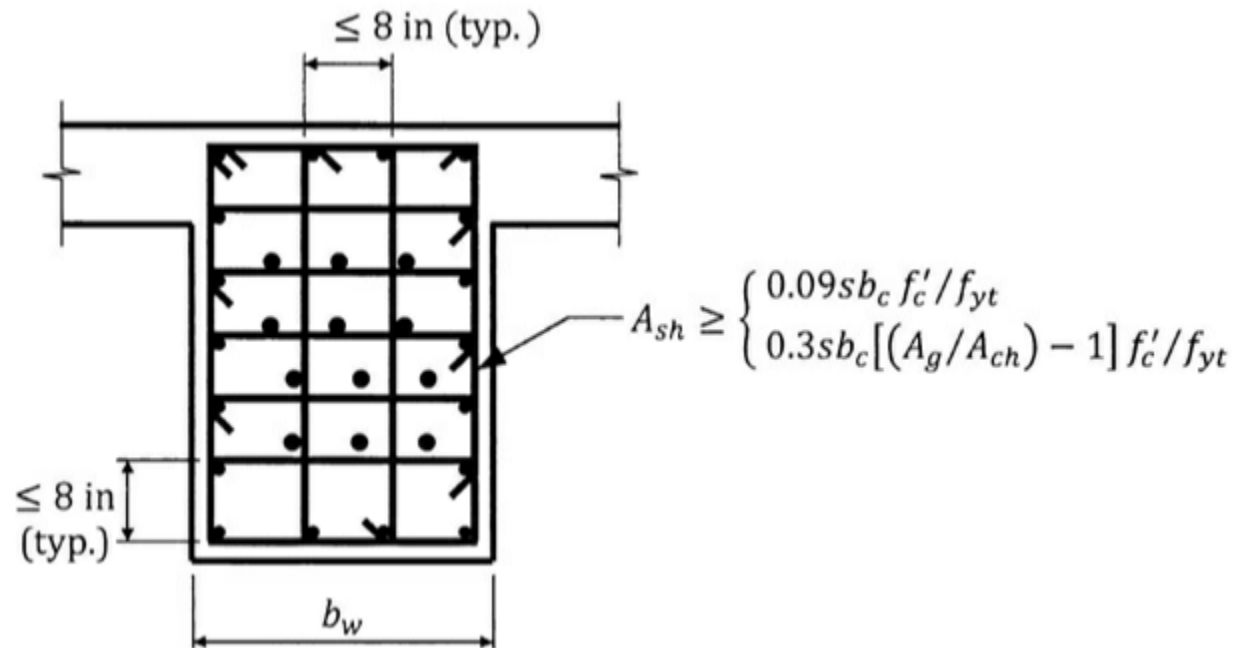

Section A-A

Foundation:

- Provisions ACI 18.13 for foundations in buildings of SDC D,E,F
- 18.13.2 for footings, foundation mats, and pile caps
 - Gives requirements for anchoring of reinforcement in vertical elements of seismic force resisting system to these foundation elements

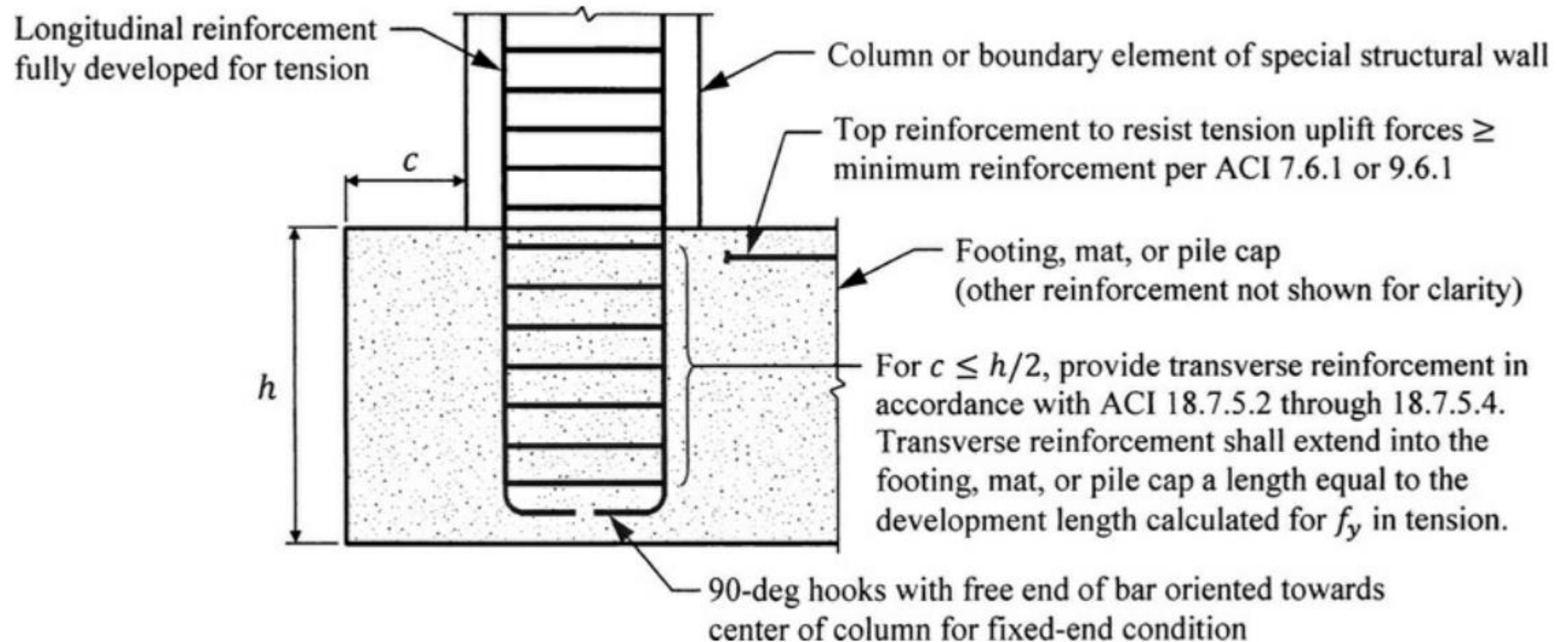

Foundation:

- Provisions ACI 18.13 for foundations in buildings of SDC D,E,F
- 18.13.2 for footings, foundation mats, and pile caps
 - Gives requirements for anchoring of reinforcement in vertical elements of seismic force resisting system to these foundation elements
- 18.13.3 for grade beams and slabs on ground
 - Sets minimum dimension and minimum reinforcement
- 18.13.4 for piles, piers and caissons
 - Indicates the type of effects to take into account in design and the minimum reinforcement allowable for these elements

Members not designated as part of the seismic force resisting system

- The provisions are applicable to the beams and columns in a building frame system where it is assumed that structural walls provide the total resistance to the earthquake effects
- The designer need to check the deformation levels that structural members “not part of lateral resisting system” are subjected and the minimum reinforcement needed to comply with forces caused by such deformations

Members not designated as part of the seismic force resisting system

- Where the induced moments and shears do not exceed the design moment and shear strength of the beam, the detailing requirements of ACI 18.14.3.2 must be satisfied

- (a) Beams shall satisfy 18.6.3.1. Transverse reinforcement shall be provided throughout the length of the beam at spacing not to exceed $d/2$. Where factored axial force exceeds $A_g f'_c / 10$, transverse reinforcement shall be hoops satisfying 18.7.5.2 at spacing s_o , according to 18.14.3.2(b).
- (b) Columns shall satisfy 18.7.4.1, 18.7.5.2, and 18.7.6. The maximum longitudinal spacing of hoops shall be s_o for the full column length. Spacing s_o shall not exceed the lesser of six diameters of the smallest longitudinal bar enclosed and 150 mm
- (c) Columns with factored gravity axial forces exceeding $0.35P_o$ shall satisfy 18.14.3.2(b) and 18.7.5.7. The amount of transverse reinforcement provided shall be one-half of that required by 18.7.5.4 and spacing shall not exceed s_o for the full column length.

Members not designated as part of the seismic force resisting system

- Where the induced moments and shears exceed the design moment and shear strength of the beam or where these values are not calculated, the detailing requirements of ACI 18.14.3.3 must be satisfied
 - (a) Materials, mechanical splices, and welded splices shall satisfy the requirements for special moment frames in 18.2.5 through 18.2.8.
 - (b) Beams shall satisfy 18.14.3.2(a) and 18.6.5.
 - (c) Columns shall satisfy 18.7.4, 18.7.5, and 18.7.6.
 - (d) Joints shall satisfy 18.8.3.1.
- Slab-Column connections must satisfy 18.14.5 related to shear reinforcement in the slab and eliminate punching failure