



FACULTY OF ENGINEERING AND TECHNOLOGY

COMPUTER SCIENCE DEPARTMENT

COMP1310

Introduction to Computer and Computing Ethics

COMPUTER BASICS

What is a computer and what is made of?

What is a Computer

- *A computer* is a device that **receives** data, **store** it and **process** it and **produce** useful information.
- So what is the difference between data and information?

Data vs. Information

- Data: raw facts representing objects and events.
 - *For example, all the names, birthdates, and genders of the students in Birzeit University*
- Information: data that is organized, meaningful and useful.
 - *For example,*
 - the percentage of female vs male students.
 - the distribution of students according to age.
 - *Decisions are made based on information, not data.*

Fundamental Characteristics of Computers

What do we look for when we want a computer?

What do we expect we use a computer?

- Speed
- Reliability
- Storage capabilities

Computer System Components

- Hardware: the physical components of a computer system.
 - *e.g., monitor, keyboard, mouse, hard drive*

- Software: the programs that execute on the computer.
 - *e.g., word processing program, Web browser*

- People:
 1. *Programmer: writes software*
 2. *End-User: purchases and uses software*

Example of Computer Specifications

		Desktop System 1	Desktop System 2
HARDWARE	CPU	2.2 GHz Intel Celeron 450	3.2 GHz Intel Core i5
	Memory		
	Cache	512 KB cache	4 MB cache
	RAM	4 GB RAM	8 GB RAM
	Hard Drive	320 GB hard drive	1 TB hard drive
	CD-ROM/DVD	DVD+/-RW drive	DVD+/-RW drive
	Input/Output		
	Keyboard	USB multifunction keyboard	wireless multifunction keyboard
	Pointing Device	USB optical mouse	wireless optical mouse
	Screen	20" HD flatscreen monitor	24" HD flatscreen monitor
	Speakers	Multimedia Speaker System	Dolby Surround Sound Speakers
Network Adapter	Integrated 10/100/1000 Ethernet	Integrated 10/100/1000 Ethernet Integrated wireless card & antenna	
SOFTWARE	Operating System	Windows 7 Home Premium	Windows 7 Professional
	Web Browser	Internet Explorer 8	Internet Explorer 8
	Productivity Suite	Microsoft Works 9	Microsoft Office Professional 2007
	Security	McAfee Security Center	McAfee Security Center

Computer Classes

- Personal Computers
- Portable Computers
- Servers
- Super Computers
- Handheld Devices
- Embedded Systems

Personal Computers

- There are three main types of personal computers:
 - *Desktop computers: less powerful but affordable; used for a variety of user applications such as email, Web browsing, document processing*
 - *Laptop computers: similar functionality to desktops, but mobile*
 - *Palmtop computers: portable, but limited applications and screen size*

The Hardware Components of a Desktop

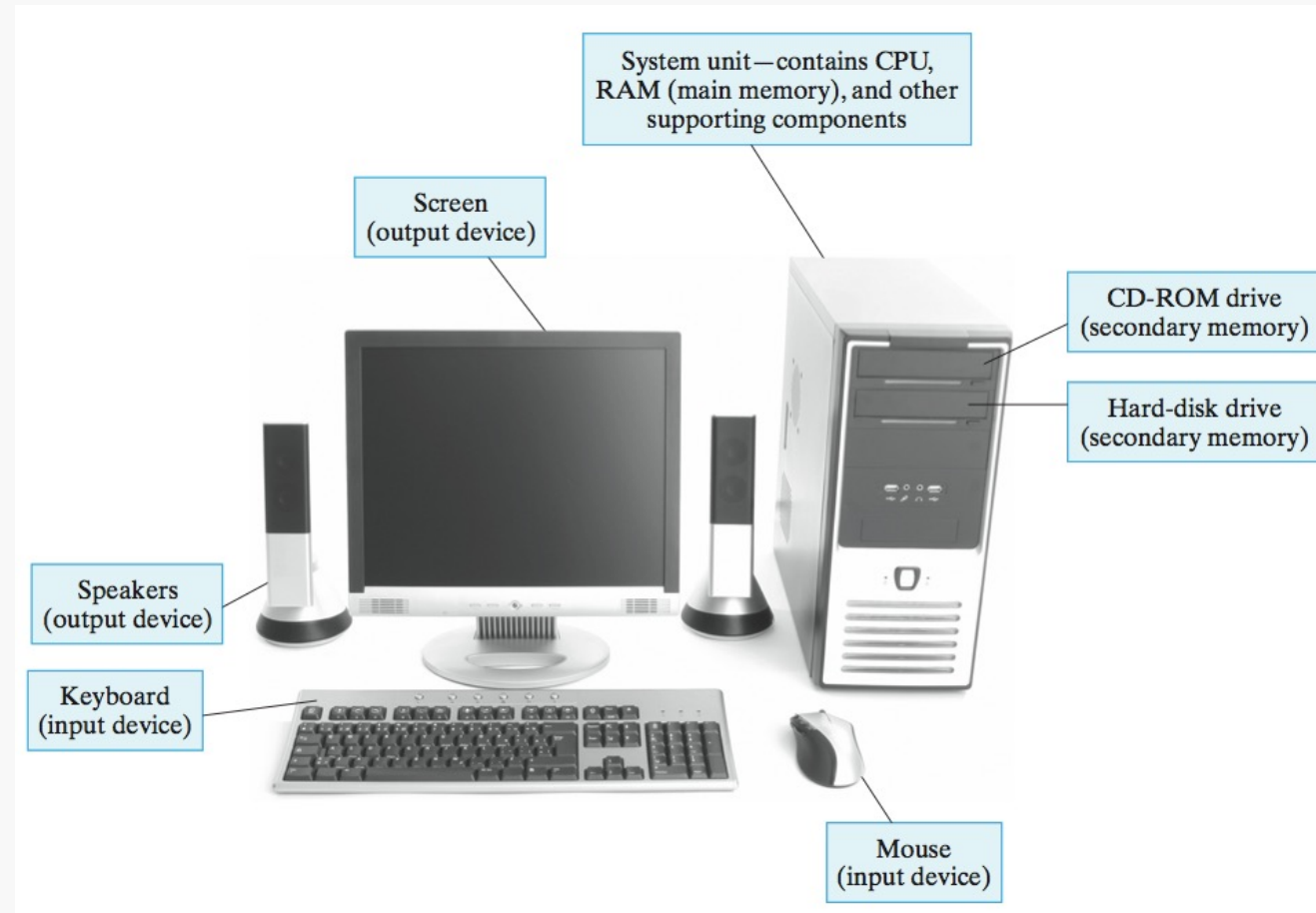

Super Computers

- Super computers are powerful but expensive.
- They are used for complex computations such as weather forecasting, engineering design and modeling

Hardware Components

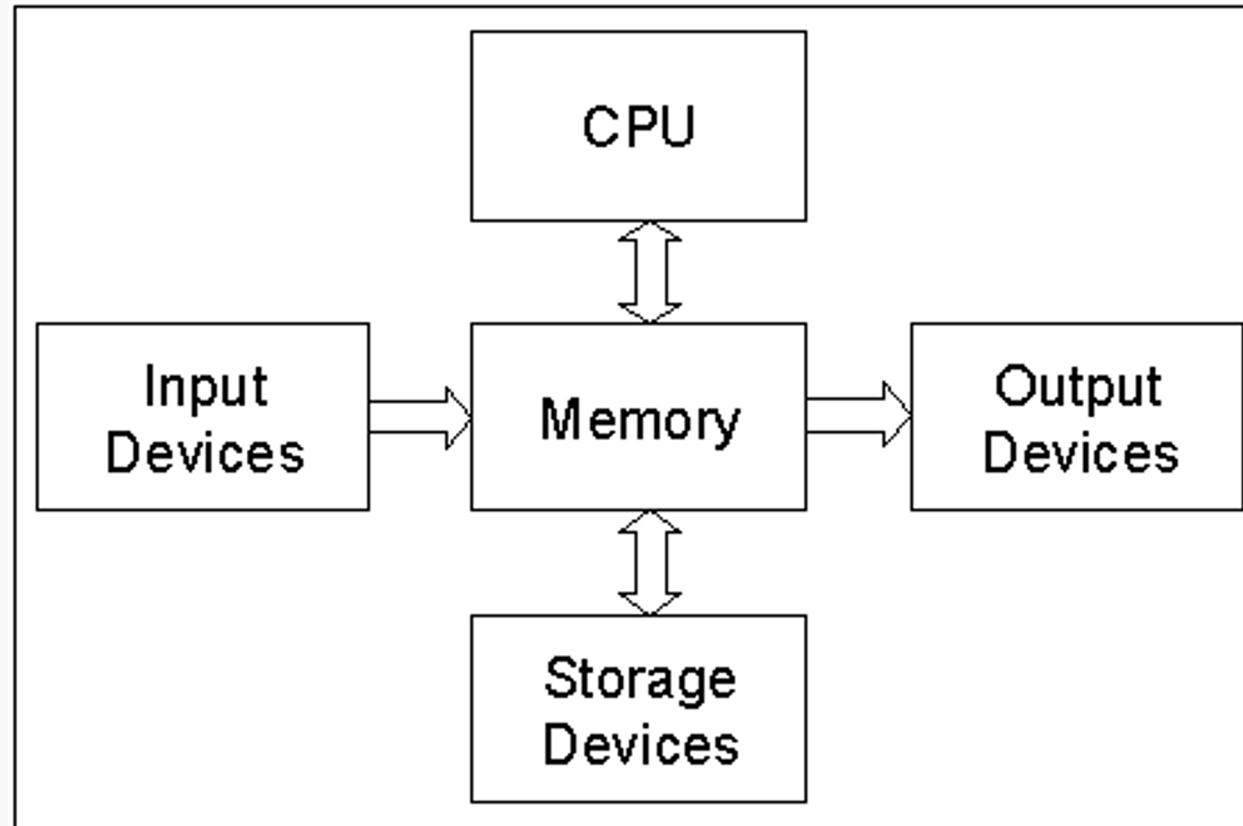

Central Processing Unit (CPU)

- Also called the *processor*.
- The CPU is the "brains" of the computer.
- Consists of electronic circuits.
- The CPU is made up of three main parts:
 - *Control Unit (CU)*
 - *Arithmetic Logic Unit (ALU)*
 - *Registers*

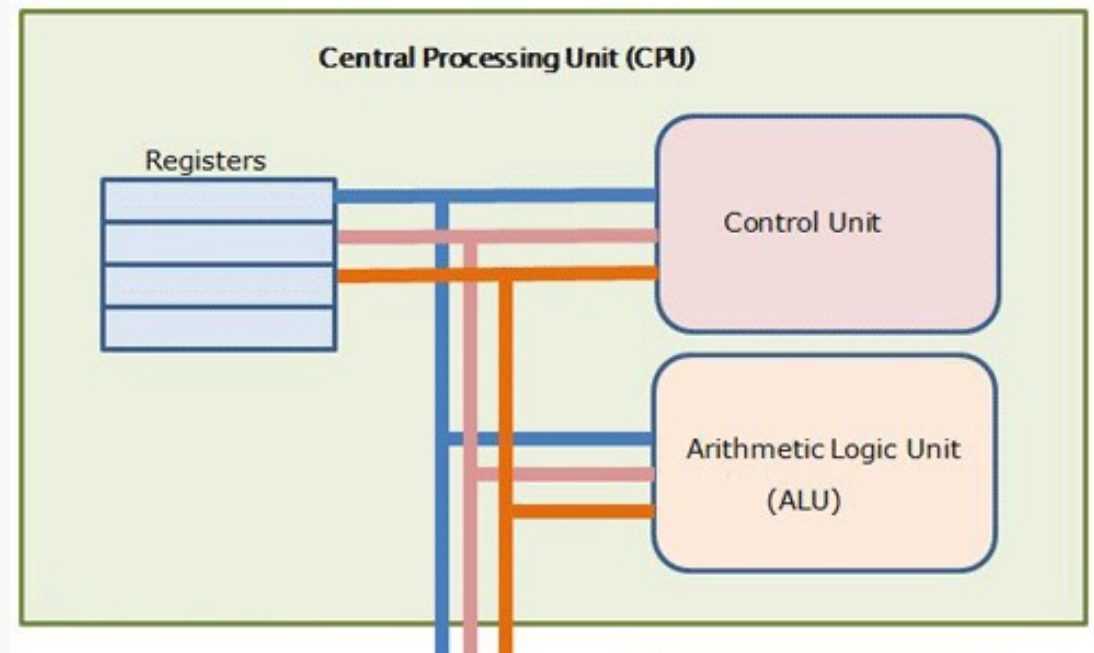

Control Unit

1. Directs the computer system to execute stored program instructions.
2. Communicate with memory and ALU
3. Sends data and instructions from secondary storage to memory as needed.

Arithmetic Logic Unit

- Execute all arithmetic and logical operations
 - *Arithmetic operation: addition, subtraction, multiplication, division*
 - *Logical operations: compare numbers, letters or special characters (equal to, less than, greater than,..)*

Registers

- High-speed temporary storage areas
 - *Storage locations located within the CPU*
- Work under direction of control unit
 - *Accept, hold, and transfer instructions or data*
 - *Keep track of where the next instruction to be executed or needed data is stored*

Memory

- The memory is that part of a computer that stores programs and data.
- Modern computers are *digital* devices, meaning they store and process information as *binary digits (bits)*
- two values of a *bit* are written as **0** and **1**, but the values could just as easily be represented as off and on, open and closed, true and false, volts and no volts, etc.

Memory – cont.

- Memory capacity is usually specified in bytes.
- A **byte** is a collection of 8 bits, and thus can represent $2^8 = 256$ different values.
 - *A byte is sufficient to represent a single character*
- A **kilobyte** is equal to 2^{10} bytes = 1,042 bytes.
 - *A kilobyte can store a few paragraphs (roughly 1 thousand characters)*
- A **megabyte** is equal to 2^{20} bytes = 1,048,576 bytes.
 - *A megabyte can store a book (roughly 1 million characters)*
- A **gigabyte** is equal to 2^{30} bytes = 1,073,741,824 bytes.
 - *A gigabyte can store a small library (roughly 1 billion characters)*
- A **terabyte** is equal to 2^{40} bytes = 1,099,511,627,776 bytes.
 - *A terabyte can store a book repository (roughly 1 trillion characters)*

Memory – cont.

- Modern computers use a combination of memory types, each with its own performance and cost characteristics.
 - *Main memory (or primary memory) is fast and expensive.*
 - *Secondary memory is slower but cheaper.*
 - Uses different technologies (magnetic signals on hard disk, reflective spots on CD)
 - Non-volatile
 - Permanent – useful for storing long-term data
 - examples: hard disk, flash drive, compact disk (CD)

RAM vs. ROM

RAM

- Random Access Memory
- Volatile
- Temporary storage
- Read and Write
- Allows the computer to read data quickly to run applications.

ROM

- Read only memory
- Non-volatile
- Permanent storage
- Read only
- Stores the program required to initially boot the computer.

Memory – cont.

- More main memory allows for quick access to more data and programs
- More secondary memory allows for storing more long-term data

Input and Output Devices (I/O)

- Input devices allow the computer to receive data from external sources
 - *examples: keyboard, mouse, microphone, scanner*
- Output devices allow the computer to display or broadcast its results
 - *examples: monitor, speaker, printer*
- How would you classify a touch screen?

Software

- Software refers to the programs that execute on that hardware.
- A software program is a collection of instructions for the computer to carry out in order to complete some task
 - e.g., word processing programs such as MS Office Word, web browsers such as Chrome or Firefox, illustration programs such as Adobe Photoshop, ...

Operating System (OS)

- An operating system is an interface between hardware and applications.
- It is responsible for the management and coordination of activities and the sharing of the limited resources of the computer.

Operating Systems (OS) – cont.

- It is a collection of programs that controls how the CPU, memory, and I/O devices work together.
- It manages the execution of all application programs, controlling how data and instructions are loaded into memory and accessed by the CPU.
- A graphical user interface operating system provides an interface for the user to interact with the computer.