

HTML 1: Overview

Abdallah Karakra & Sobhi Ahmed

Chapter 2

HTML DEFINED

What Is HTML and Where Did It Come from?

HTML

- HTML is defined as a **markup language**.
- **markup** is a way to indicate information about the content that is distinct from the content.
- This “information about content” in HTML is implemented via **tags**.

Paragraph	<code><p> Some text </p></code>	Some text
Bold	<code> Bold text </code>	Bold text
Italics	<code><i> Italic text </i></code>	<i>Italic text</i>

What Is HTML and Where Did It Come from?

HTML

The term comes from the days of print, when editors would write instructions on manuscript pages that might be revision instructions to the author or copy editor.

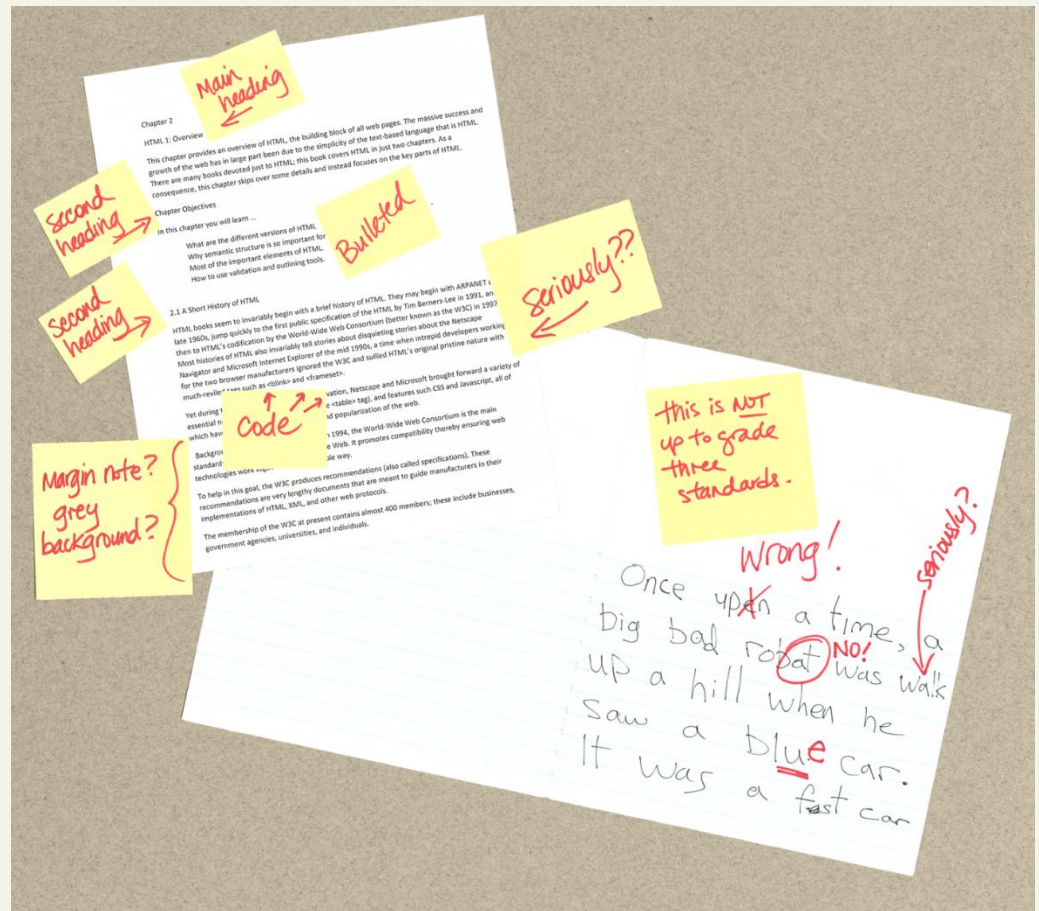

Html Versions

Since the early days of the web, there have been many versions of HTML:

Version	Year
HTML	1991
HTML 2.0	1995
HTML 3.2	1997
HTML 4.01	1999
XHTML	2000
HTML5	2014

What Is HTML and Where Did It Come from?

HTML 5

- Widely implemented in modern browsers
- The current W3C recommendation for web development
- Still relatively new and not always taught.

HTML SYNTAX

HTML Syntax

Elements and Attributes

- HTML documents are composed of **textual content** and **HTML elements**
- HTML element encompasses
 - the **element name** within angle brackets (i.e., the **tag**) and
 - HTML elements can also contain **attributes**.
 - **the content** within the tag.



HTML Syntax

- Elements and Attributes

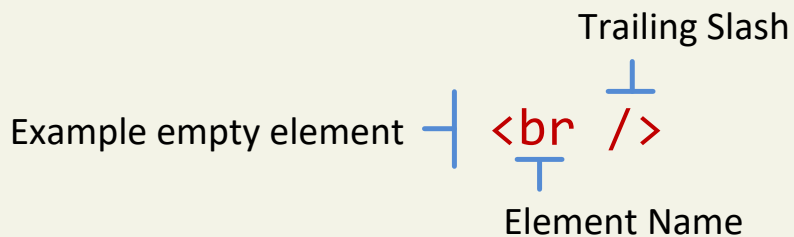

In HTML5, the trailing slash in empty elements is optional.

HTML Syntax

Elements and Attributes

An **empty element** does not contain any text content; instead, it is an **instruction to the browser to do something**.

In HTML5, the trailing slash in empty elements is optional.

Example empty element ``

Element name Trailing slash (*optional*)

Example empty element `
`

Element Name Trailing Slash

Elements and Attributes

More syntax

HTML documents are composed of **textual content** and **HTML elements**.

An **HTML element** can **contain text, other elements**, or **be empty**. It is identified in the HTML document by tags.

HTML elements can also contain attributes. An **HTML attribute** is a **name=value** pair that provides more information about the HTML element.

Elements and Attributes



- **Element name :a**
- **Attribute → name: href
value: http://www.centralpark.com**
- **Content: Central Park**
- **<a> : opening tag**
- **: closing tag**

Hierarchy of elements (Nesting HTML elements)

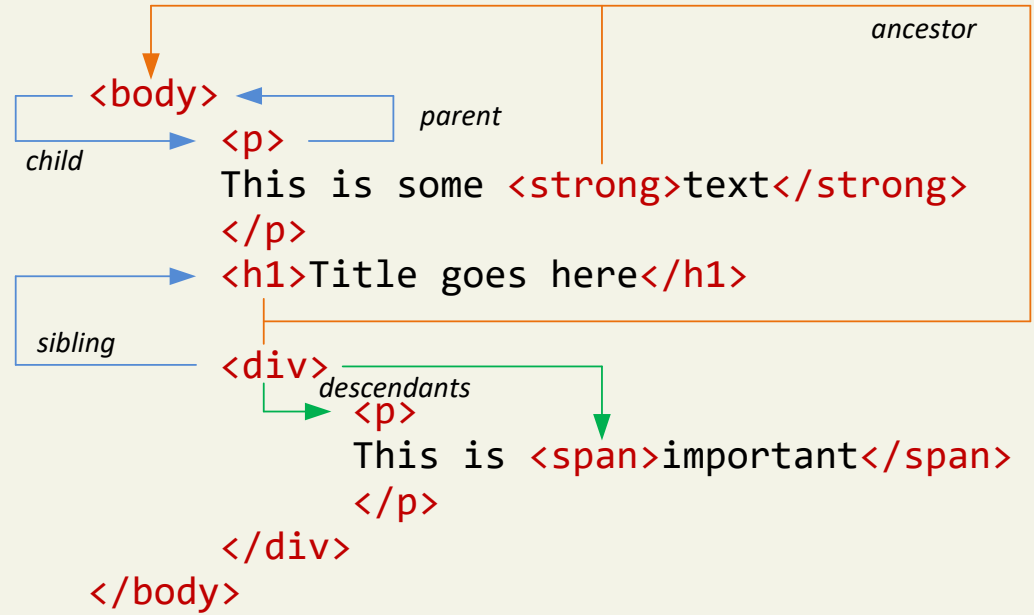

Often an HTML element will contain other HTML elements. In such a case, the container element is said to be a parent of the contained, or child, element. Any elements contained within the child are said to be **descendants** of the parent element; likewise, any given child element, may have a variety of **ancestors**.

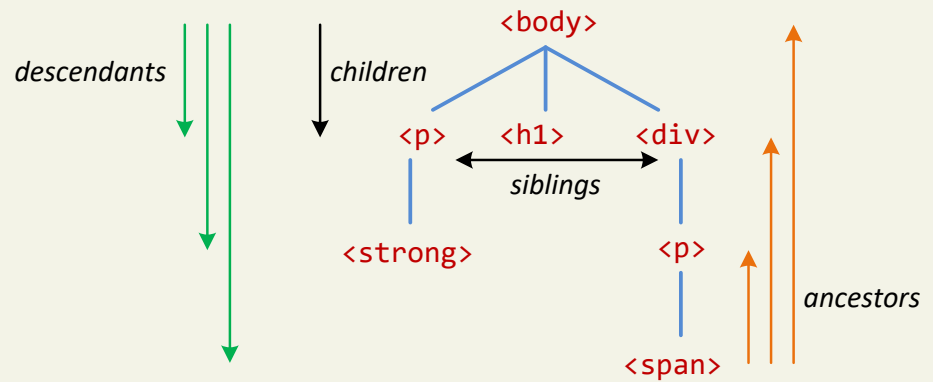

HTML Syntax

Nesting HTML Elements

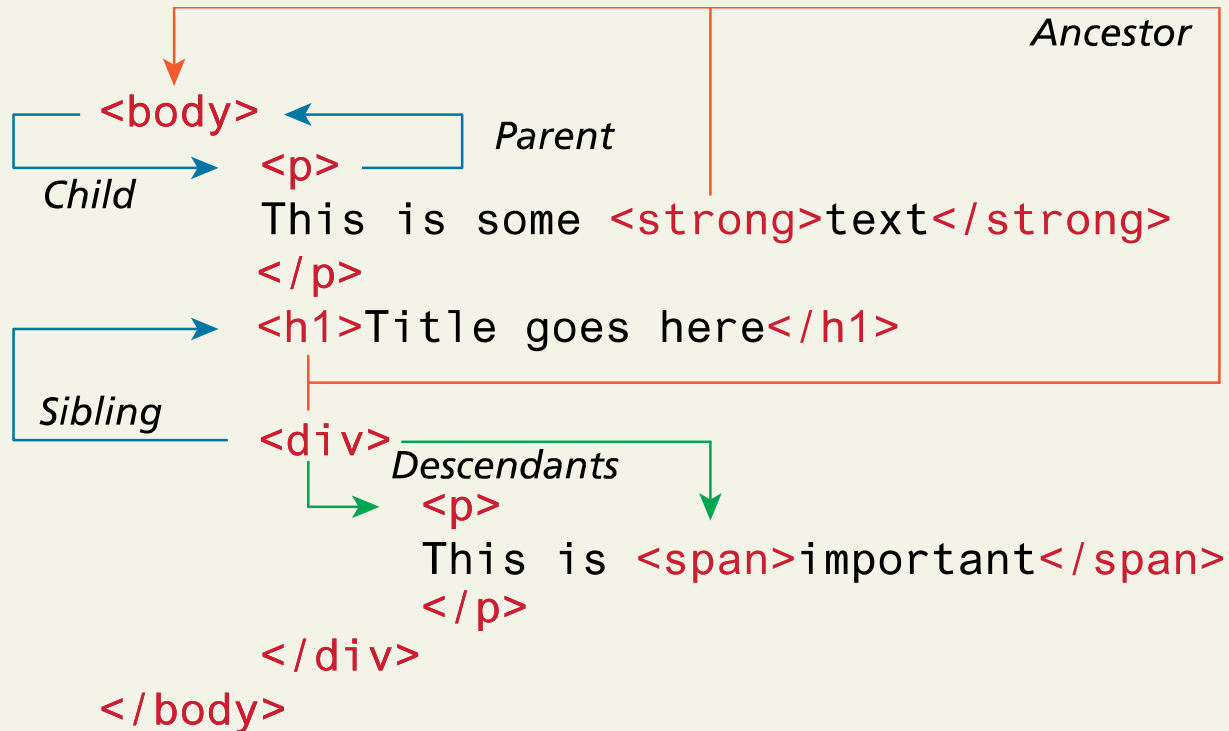

HTML Syntax

Nesting HTML Elements

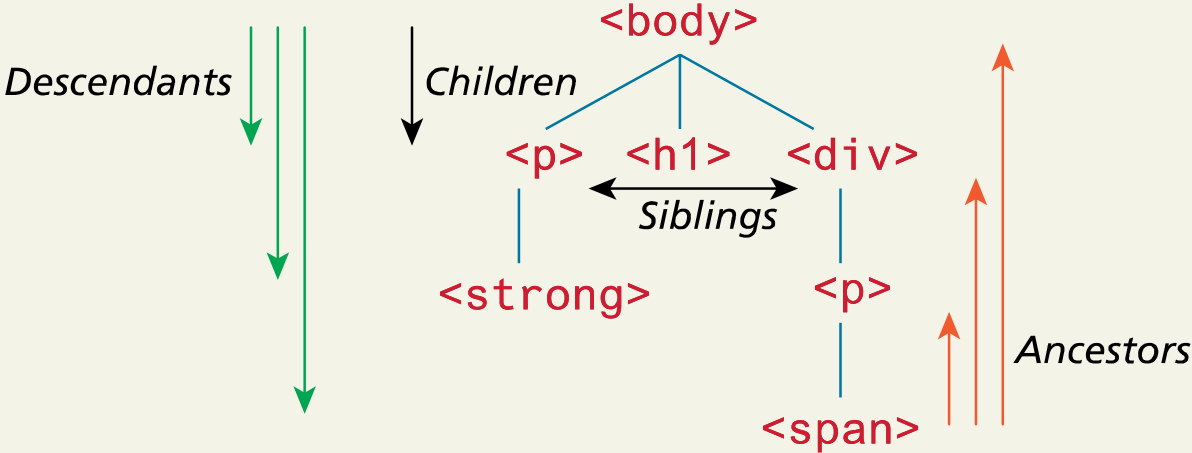

Nesting HTML elements

In order to properly construct a hierarchy of elements, your browser expects each HTML nested element to be properly nested.

That is, a child's ending tag must occur before its parent's ending tag.

Correct Nesting

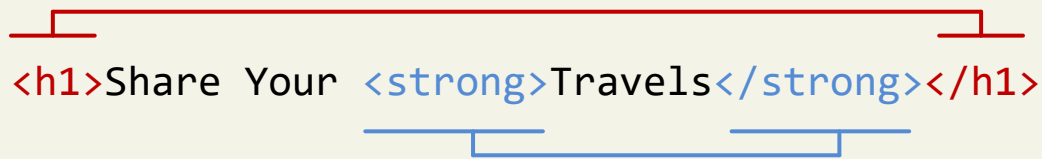

```
<h1>Share Your <strong>Travels</strong></h1>
```

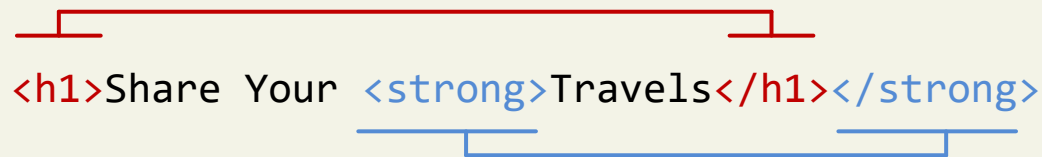

```
<h1>Share Your <strong>Travels</h1></strong>
```

Incorrect Nesting

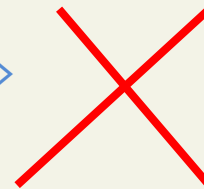

Section 3 of 6

SEMANTIC MARKUP

Hypertext Markup Language (HTML)

- Describes the *content* and *structure* of information on a web page
- **Not the same as the presentation** (appearance on screen)



Semantic Markup

- That is, the element itself conveys **some information about the type of content contained between the opening and closing tags.**
- For example, when a browser encounters an **h1 heading** it interprets that tag to mean that the contents of the h1 element constitute the **most important heading** of the section that contains the element.
- The semantic meaning of an h1 tag is that it is used to identify the most important header of a specific web page or section

semantic elements like `<header>`, `<footer>`, `<article>`, and `<section>`.

Structure

All of the tags that we will use to describe the basic structural information in a document, such as articles, headings, lists, paragraphs, links, images, navigation, footers, and so on.

Section 4 of 6

STRUCTURE OF HTML

STRUCTURE OF HTML

```
<!DOCTYPE html>
<html>
  <head>
    information about the page
  </head>
  <body>
    page contents
  </body>
</html>
```

- The **header** describes the page and the **body** contains the page's contents
- an HTML page is saved into a file ending with **extension .html**
- **DOCTYPE** tag tells browser to interpret our page's code as **HTML5**, the latest/greatest version of the language

Simplest HTML document



```
<!DOCTYPE html>
<html>
  <head>
    <title> A Very Small Document</title>
  </head>
  <body>
    This is a simple document with no much content
  </body>
</html>
```

Simplest HTML document

```
<!DOCTYPE html>
<html>
  <head>
    <title> A Very Small Document</title>
  </head>
  <body>
    This is a simple document with no much content
  </body>
</html>
```

The title of the web page

- Placed within the head of the page
- Displayed in the web browser's title bar and when bookmarking the page

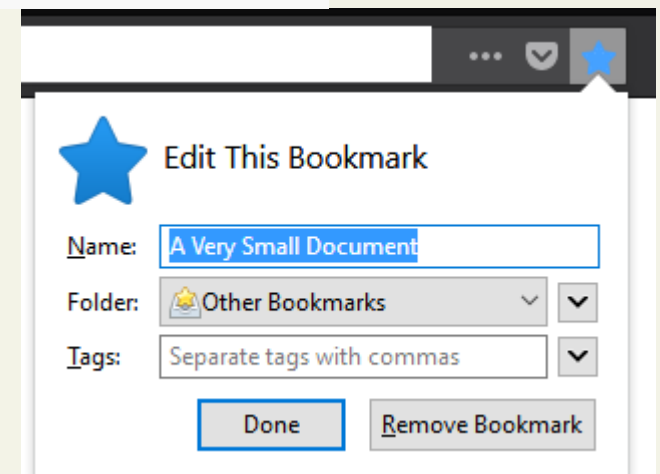

A more complete document

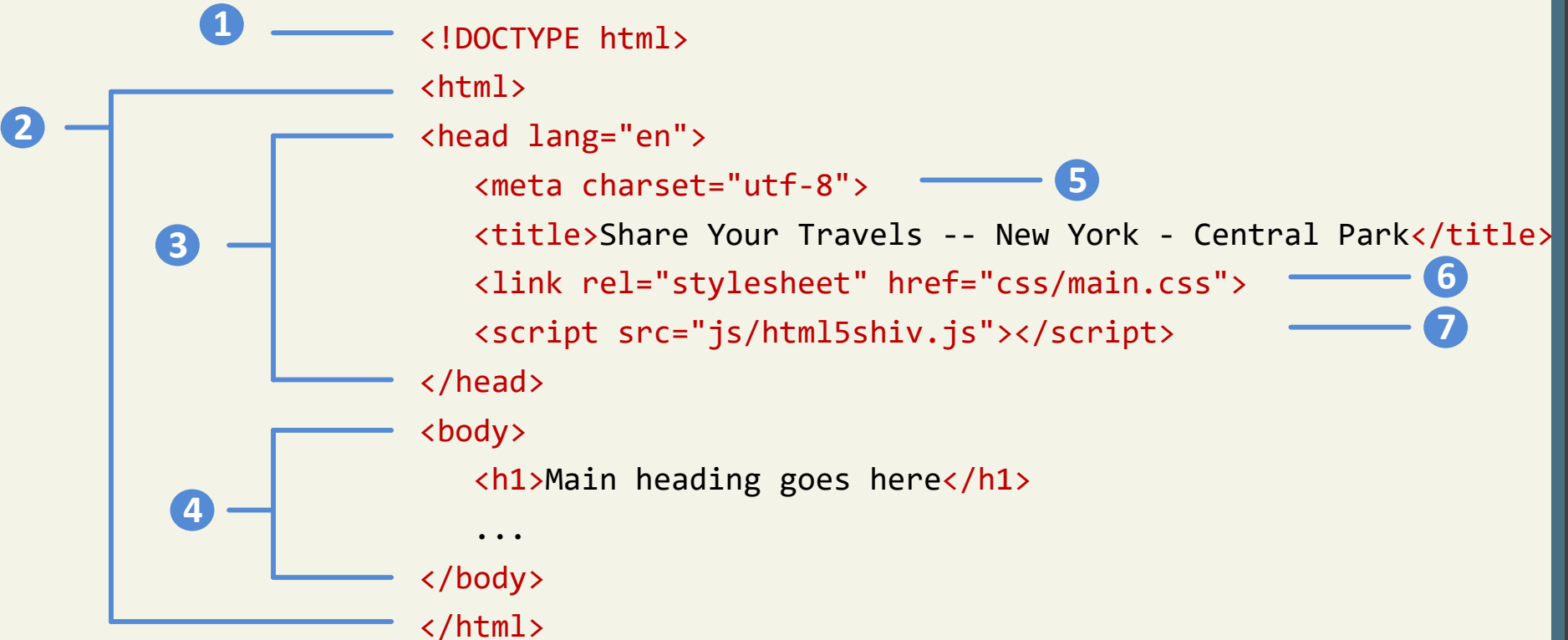

CSS: for presentation
JavaScript: for dynamic

1 DOCTYPE

(short for **Document Type Definition**) (DTD)

XHTML 1.0

```
<!DOCTYPE html PUBLIC "-//W3C//DTD XHTML 1.0  
Transitional//EN"  
http://www.w3.org/TR/xhtml1/DTD/xhtml1-  
transitional.dtd>
```

Tells the browser (or any other client software that is reading this HTML document) **what type of document it is about to process.**

Notice that it **does not indicate what version of HTML** is contained within the document: **it only specifies that it contains HTML.**



HTML, Head, and Body

- 2 The `<html>` element is sometimes called the **root element** as it contains all the other HTML elements in the document.

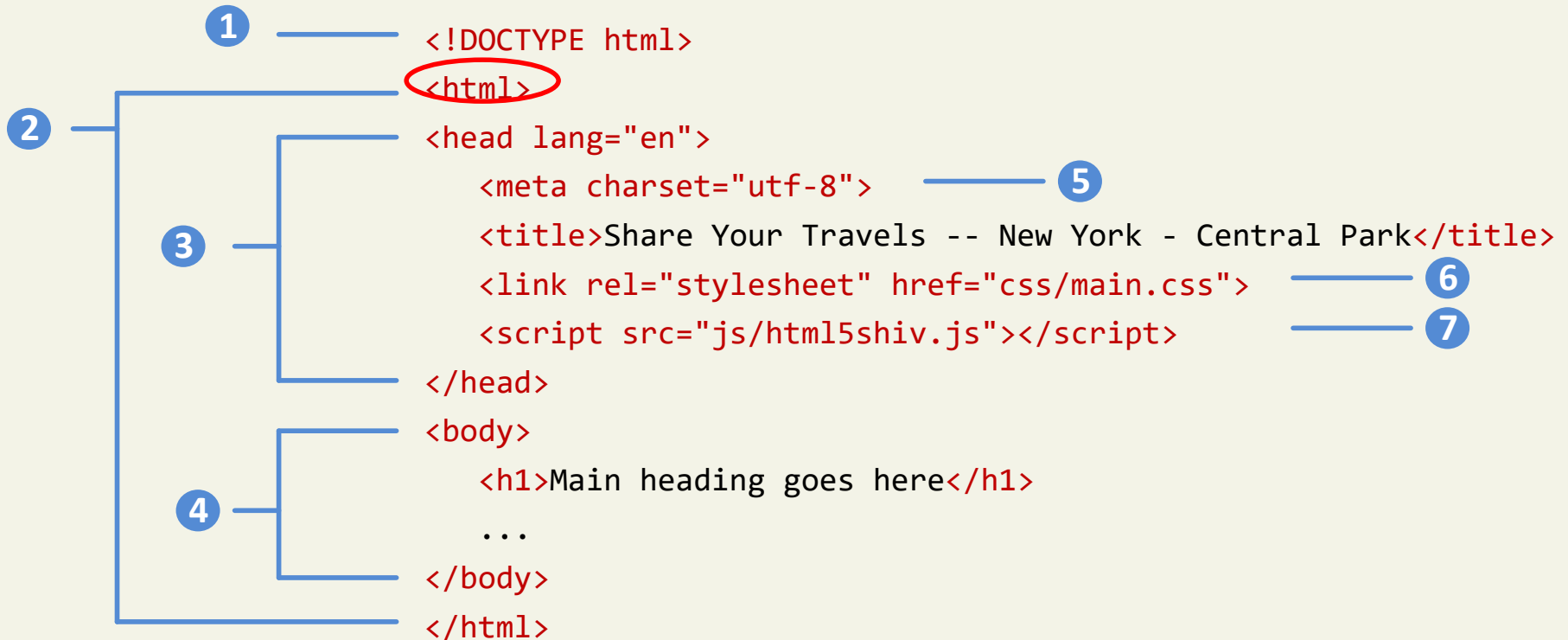

Head and Body

HTML pages are divided into two sections: the **head** and the **body**, which correspond to the `<head>` and `<body>` elements.

- 3 The head contains **descriptive elements *about* the document**
- 4 The body contains **content that will be displayed by the browser.**



Inside the head

There are no brains

You will notice that the `<head>` element contains a variety of additional elements.

- 5 The first of these is the `<meta>` element. Our example declares that the character encoding for the document is UTF-8.

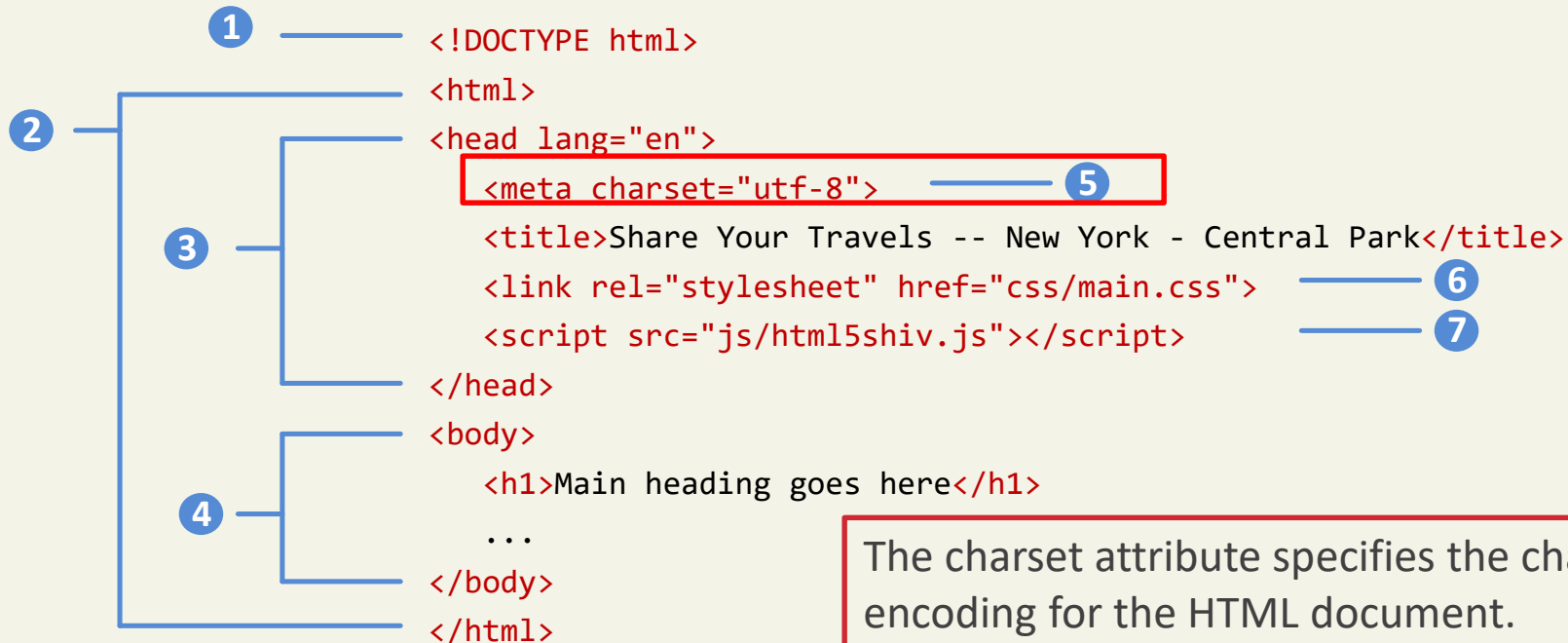

The charset attribute specifies the character encoding for the HTML document.

UTF-8 : Character encoding for Unicode

Inside the head

No brains but metas, styles and javascripts

- 6 Our example specifies an external CSS style sheet file that is used with this document.
- 7 It also references an external Javascript file.

```
1  <!DOCTYPE html>
   <html>
2  <head lang="en">
   <meta charset="utf-8"> 5
   <title>Share Your Travels -- New York - Central Park</title>
   <link rel="stylesheet" href="css/main.css"> 6
   <script src="js/html5shiv.js"></script> 7
   </head>
4  <body>
   <h1>Main heading goes here</h1>
   ...
   </body>
   </html>
```

CSS: for presentation
JavaScript: for dynamic

Section 5 of 6

QUICK TOUR OF HTML

Why a quick tour?

HTML5 contains many structural and presentation elements – too many to completely cover in this presentation.

Rather than comprehensively cover all these elements, this presentation will provide a quick overview of the most common elements.

Paragraph: `<p>`

paragraphs of text (block)

`<p>`

This paragraph contains a lot of lines in the source code, but the browser ignores it.

`</p>`

`<p>`

This paragraph contains a lot of spaces in the source code, but the browser ignores it.

`</p>`

`<p>`

The number of lines in a paragraph depends on the size of your browser window. If you resize the browser window, the number of lines in this paragraph will change.

`</p>`

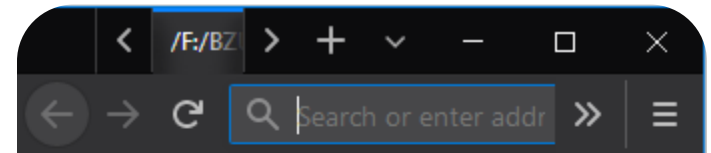
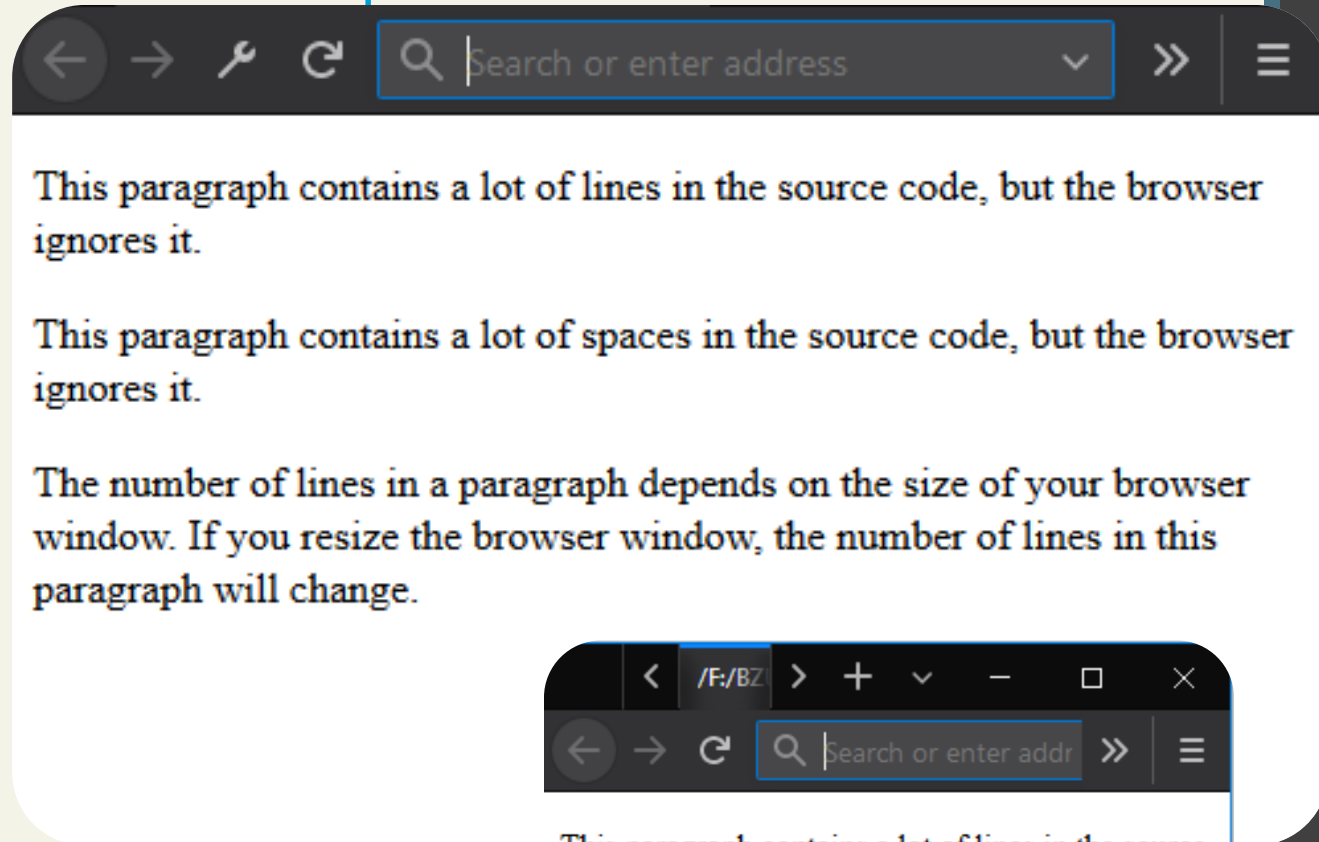

This paragraph contains a lot of lines in the source code, but the browser ignores it.

This paragraph contains a lot of spaces in the source code, but the browser ignores it.

The number of lines in a paragraph depends on the size of your browser window. If you resize the browser window, the number of lines in this paragraph will change.

Headings: `<h1>`, `<h2>`, ..., `<h6>`

headings to separate major areas of the page (block)

```
<h1>Birzeit University</h1>
```

```
<h2>Faculty of Engineering and Technology</h2>
```

```
<h3>Department of Computer Science</h3>
```

```
<h4>Birzeit University</h4>
```

```
<h5>Faculty of Engineering and Technology</h5>
```

```
<h6>Department of Computer Science</h6>
```

Birzeit University

Faculty of Engineering and Technology

Department of Computer Science

Birzeit University

Faculty of Engineering and Technology

Department of Computer Science

Tip: Use h1 to h6 elements only for headings. Do not use them just to make text bold or big. Use other tags for that.

Horizontal rule: `<hr>`

a horizontal line to visually separate sections of a page (block)

```
<p>First paragraph</p>  
<hr />  
<p>Second paragraph</p>
```

First paragraph

Second paragraph

Links: <a>

links, or "anchors", to other pages (inline)

```
<p> Search
```

```
<a href="http://www.google.com/">Google</a> or our  
<a href="lectures.html">Lecture Notes</a>. </p>
```

Search Google or our Lecture Notes.



- Uses the **href attribute** to specify the **destination URL**
- can be **absolute (to another web site)** or **relative (to another page on this site)**
- anchors are inline elements

Line break:

forces a line break (inline)

```
<p>Birzeit Uiniversity <br /> Computer Science.</p>
```

```
<p>Department <br /> Welcome Comp334 Students </p>
```

Birzeit Uiniversity
Computer Science.

Department
Welcome Comp334 Students

- Warning: Don't over-use br (guideline: ≥ 2 in a row is bad)

Images:

inserts a graphical image into the page (inline)

```

```

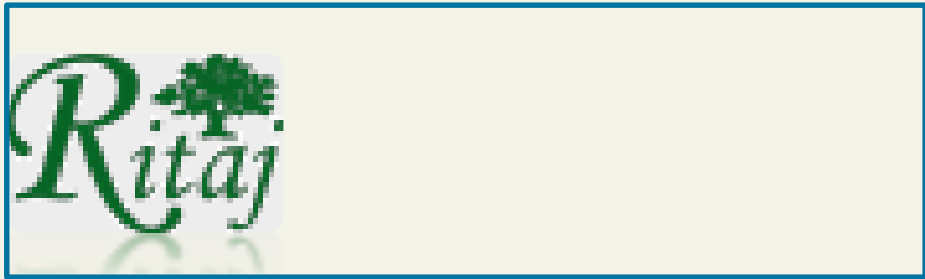

- The **src** attribute **specifies the image URL**
- HTML5 also requires an alt attribute describing the image

More about images

```
<a href="http://www.ritaj.birzeit.edu/">  </a>
```

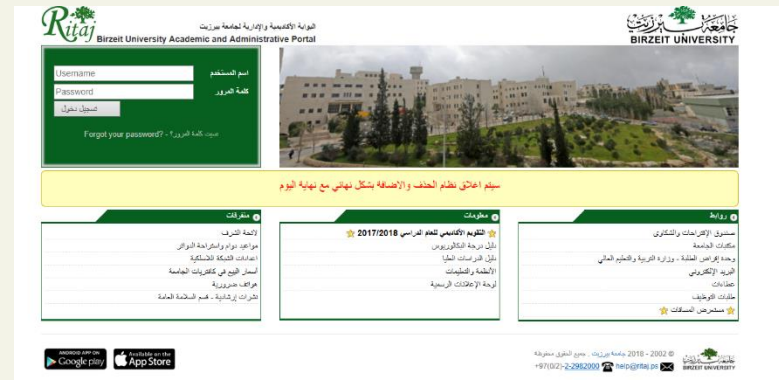
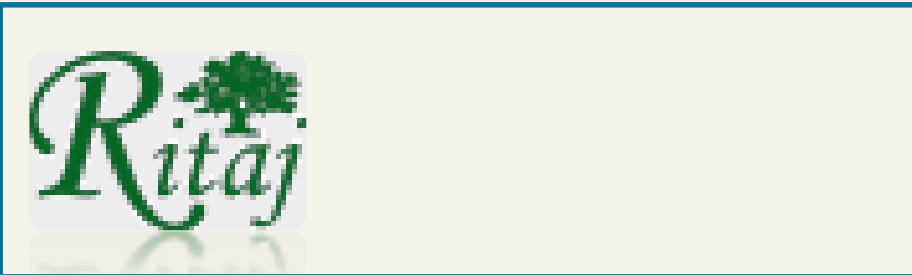

If placed in an **a** anchor, the image becomes a link

Phrase elements : ``, ``

em: emphasized text (usually rendered in *italic*)

strong: strongly emphasized text (usually rendered in **bold**)

```
<p> HTML is <em>really</em>,  
<strong>REALLY</strong> fun! </p>
```

HTML is *really*, **REALLY** fun!

Nesting tags

```
<p> HTML is <em>really</em>,  
<strong>REALLY</strong> fun! </p>
```

```
<p>  
  <em>  
    </em>  
  <strong>  
    </strong>  
</p>
```

- Tags must be correctly nested
(a closing tag must match the most recently opened tag)
- The browser may render it correctly anyway, but it is invalid HTML
(how would we get the above effect in a valid way?)

Comments: `<!-- ... -->`

comments to document your HTML file or "comment out" text

```
<!-- Author: Abdallah Karakra, Web Application Course-->  
<p>Computer Science courses have <!-- NOT --> a lot of  
fun!</p>
```

Computer Science courses have a lot of fun!

- Many web pages are not thoroughly commented (or at all)
- Still useful at top of page and for disabling code

Unordered list: ``, ``

`ul` represents a bulleted list of items (block)

`li` represents a single item within the list (block)

```
<ul>  
  <li>Coffee</li>  
  <li>Tea</li>  
  <li>Milk</li>  
</ul>
```

- Coffee
- Tea
- Milk

More about unordered lists

a list can contain other lists

```
<ul>
  <li>Chapter 1:
    <ul>
      <li>section 1</li>
      <li>section 2</li>
    </ul>
  </li>

  <li>Chapter 2:
    <ul>
      <li>section 1</li>
      <li>Section 2</li>
    </ul>
  </li>
</ul>
```

- Chapter 1:
 - section 1
 - section 2
- Chapter 2:
 - section 1
 - Section 2

Lists

<h2>Unordered List with Disc Bullets</h2>

```
<ul style="list-style-type:disc">  
  <li>Coffee</li>  
  <li>Tea</li>  
  <li>Milk</li>  
</ul>
```

Unordered List with Disc Bullets

- Coffee
- Tea
- Milk

<h2>Unordered List with Circle Bullets</h2>

```
<ul style="list-style-type:circle">  
  <li>Coffee</li>  
  <li>Tea</li>  
  <li>Milk</li>  
</ul>
```

Unordered List with Circle Bullets

- Coffee
- Tea
- Milk

Style	Description
list-style-type:disc	The list items will be marked with bullets (default)
list-style-type:circle	The list items will be marked with circles
list-style-type:square	The list items will be marked with squares
list-style-type:none	The list items will not be marked

Ordered list:

ol represents a numbered list of items (block)

```
<p>An Ordered HTML List:</p>  
<ol>  
  <li>Coffee </li>  
  <li>Tea</li>  
  <li>Milk</li>  
</ol>
```

An Ordered HTML List:

1. Coffee
2. Tea
3. Milk

Ordered list: More examples

```
<h2>Ordered List with Letters</h2>
```

```
<ol type="A">  
  <li>Coffee</li>  
  <li>Tea</li>  
  <li>Milk</li>  
</ol>
```

Ordered List with Letters

- A. Coffee
- B. Tea
- C. Milk

```
<h2>Ordered List with Roman Numbers</h2>
```

```
<ol type="I">  
  <li>Coffee</li>  
  <li>Tea</li>  
  <li>Milk</li>  
</ol>
```

Ordered List with Roman Numbers

- I. Coffee
- II. Tea
- III. Milk

Type	Description
type="1"	The list items will be numbered with numbers (default)
type="A"	The list items will be numbered with uppercase letters
type="a"	The list items will be numbered with lowercase letters
type="I"	The list items will be numbered with uppercase roman numbers
type="i"	The list items will be numbered with lowercase roman numbers

Definition list: `<dl>`, `<dt>`, `<dd>`

*dl represents a list of definitions of terms (block)
dt represents each term, and dd its definition*

```
<dl>  
  <dt>Coffee</dt>  
    <dd>- black hot drink</dd>  
  <dt>Milk</dt>  
    <dd>- white cold drink</dd>  
</dl>
```

Coffee

- black hot drink

Milk

- white cold drink

Quotations: `<blockquote>`

a lengthy quotation (block)

```
<p>As Abdallah Karakra said in his A-RSA Paper:</p>
```

```
<blockquote>
```

```
  Even though, RSA seems to be robust and secure, attackers  
  succeeded to exploit some properties of RSA algorithm and its  
  implementation to carry out some attacks.
```

```
</blockquote>
```

As Abdallah Karakra said in his A-RSA Paper:

→ Even though, RSA seems to be robust and secure, attackers succeeded to exploit some properties of RSA algorithm and its implementation to carry out some attacks.

The `<blockquote>` tag specifies a **section** that is quoted from another source.

Browsers usually **indent** `<blockquote>` elements.

Inline quotations: `<q>`

```
<p>WWF's goal is to:  
<q>Build a future where people live in harmony with  
nature.</q> We hope they succeed.</p>
```

WWF's goal is to: “Build a future where people live in harmony with nature.” We hope they succeed.

The `<q>` tag defines a **short quotation**.
Browsers normally insert quotation marks around the quotation.

HTML Character Entities

a way of representing any Unicode character within a web page

character(s)	entity
< >	< >
é è ñ	é è ñ
™ ©	™ ©
π δ Δ	π δ Δ
И	И
" &	" &

HTML-encoding text

```
<p> <a  
href=&quot;http://google.com/search?q=Birzeit&amp;ie=utf-8&quot;&gt;  
Search Google for Birzeit &lt;/a&gt; &lt;/p&gt;
```

```
<p> <a href="http://google.com/search?q=Birzeit&ie=utf-8"> Search Google for Birzeit </a> </p>
```

Deletions and insertions: ``, `<ins>`

content that should be considered deleted or added to the document (inline)

```
<p>  
<del>Final Exam</del><ins>Midterm</ins>is on<del>Aug 29</del><ins>Apr 17</ins>  
</p>
```

~~Final Exam~~ Midterm is on ~~Aug 29~~ Apr 17.

Tip: Use `` and `<ins>` to markup updates and modifications in a document

Preformatted text: `<pre>`

a large section of pre-formatted text (block)

```
<pre>
  Web application course
is a fun course
Be fun

</pre>
```

```
    Web application course
is a fun course
Be fun
```

displayed with exactly the whitespace / line breaks given in the text

Web Standards

It is important to write proper HTML code and follow proper syntax.

Why use valid HTML and web standards?

- More **rigid** and **structured language**
- More interoperable **across different web browsers**
- More likely that our pages will **display correctly in the future**

<https://validator.w3.org/>

checks your HTML code to make sure it follows the official HTML syntax

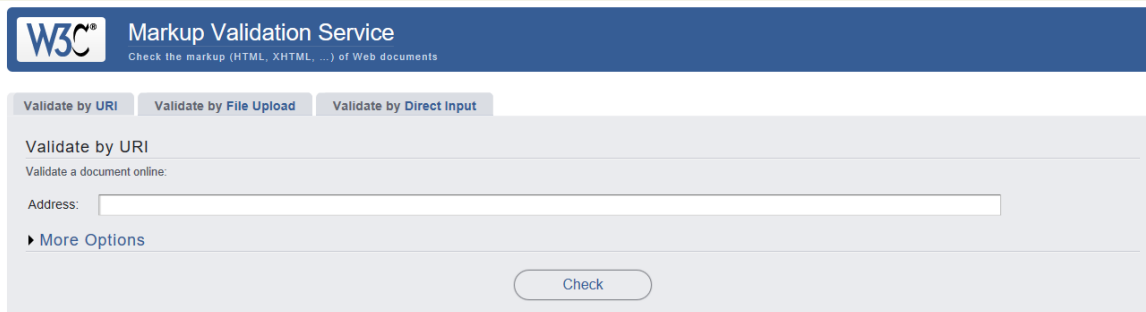

The screenshot shows the W3C Markup Validation Service interface. At the top, there is a blue header with the W3C logo and the text "Markup Validation Service" and "Check the markup (HTML, XHTML, ...) of Web documents". Below the header, there are three tabs: "Validate by URI", "Validate by File Upload", and "Validate by Direct Input". The "Validate by URI" tab is selected. Underneath, there is a section titled "Validate by URI" with the text "Validate a document online:". Below this, there is a label "Address:" followed by a text input field. At the bottom of the form, there is a "Check" button and a link for "More Options".

This validator checks the [markup validity](#) of Web documents in HTML, XHTML, SMIL, MathML, etc. If you wish to validate specific content such as [RSS/Atom feeds](#) or [CSS stylesheets](#), [MobileOK content](#), or to [find broken links](#), there are [other validators and tools](#) available. As an alternative you can also try our [non-DTD-based validator](#).

https://validator.w3.org/

Nu Html Checker

This tool is an ongoing experiment in better HTML checking, and its behavior remains subject to change

Showing results for uploaded file `smallDocument.html`

Checker Input

Show source outline image report

Check by

Uploaded files with `.xhtml` or `.xht` extensions are parsed using the XML parser.

Document checking completed. No errors or warnings to show.

Used the HTML parser.

Total execution time 2 milliseconds.

[About this checker](#) • [Report an issue](#) • Version: 18.2.20

Nu Html Checker

This tool is an ongoing experiment in better HTML checking, and its behavior remains subject to change

Showing results for `smallDocument.html`

Checker Input

Show source outline image report

Check by

`smallDocument.html`

1. **IO Error** Missing scheme

2. **IO Error** Missing scheme

The result cannot be determined due to a non-document-error.

Sample Document

```
<!DOCTYPE html>
<html>
<head lang="en">
  <meta charset="utf-8">
  <title>Share Your Travels -- New York - Central Park</title>
  <link rel="stylesheet" href="css/main.css">
  <script src="js/html5shiv.js"></script>
</head>
```

view page in browser

<body>

1 `<h1>Share Your Travels</h1>`

2 `<h2>New York - Central Park</h2>`

`<p>Photo by Randy Connolly</p>`

`<p>This photo of Conservatory Pond in`

`Central Park` 3

New York City was taken on October 22, 2011 with a

`Canon EOS 30D camera.`

`</p>` 4

5 ``

`<h3>Reviews</h3>`

6 `<div>`

`<p>By Ricardo on <time>September 15, 2012</time></p>`

`<p>Easy on the HDR buddy.</p>`

`</div>`

`<div>`

`<p>By Susan on <time>October 1, 2012</time></p>`

`<p>I love Central Park.</p>`

`</div>` 8

`<p><small>Copyright © 2012 Share Your Travels</small></p>`

`</body>` 9

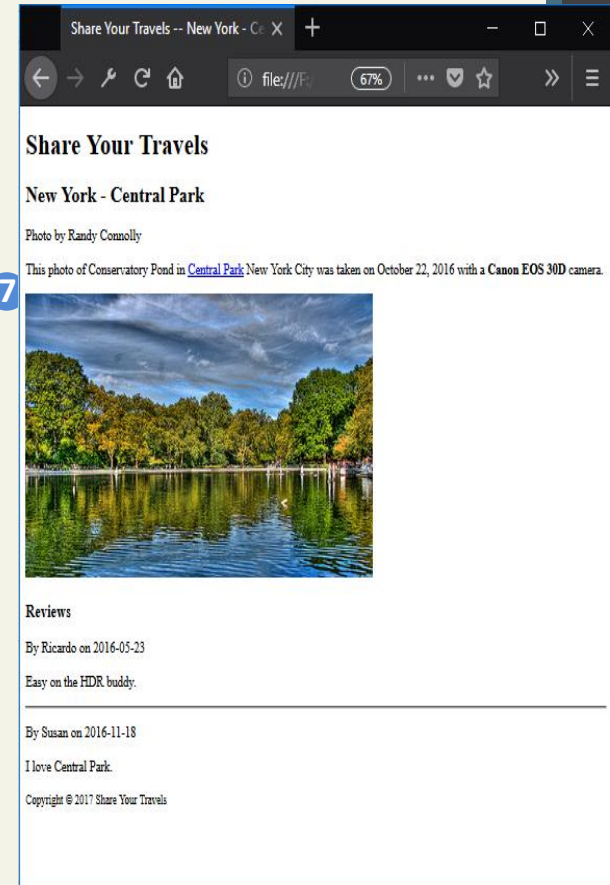

1 Headings

<h1>, <h2>, <h3>, etc

HTML provides six levels of heading (**h1**, **h2**, **h3**, ...), with the higher heading number indicating a heading of less importance.

Headings are an essential way for document authors use to show their readers the structure of the document.

<body>

1

<h1>Share Your Travels</h1>

<h2>New York - Central Park</h2>

My Term Paper Outline

1. Introduction

2. Background

2.1 Previous Research

2.2 Unresolved issues

3. My Solution

3.1 Methodology

3.2 Results

3.3 Discussion

4. Conclusion

```
<!DOCTYPE html>
<html>
<head lang="en">
  <meta charset="utf-8">
  <title>Term Paper Outline</title>
</head>
<body>
  <h1>Term Paper Outline</h1>

  <h2>Introduction</h2>

  <h2>Background</h2>
  <h3>Previous Research</h3>
  <h3>Unresolved Issues</h3>

  <h2>My Solution</h2>
  <h3>Methodology</h3>
  <h3>Results</h3>
  <h3>Discussion</h3>

  <h2>Conclusion</h2>
</body>
</html>
```

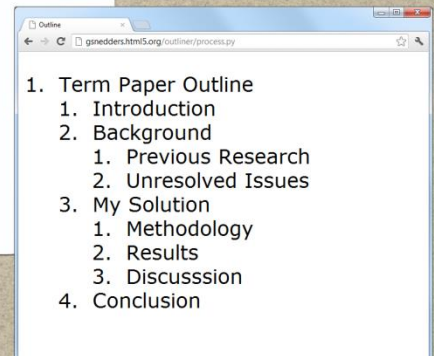

Headings

The browser has its own default styling for each heading level.

However, these are easily modified and customized via CSS.

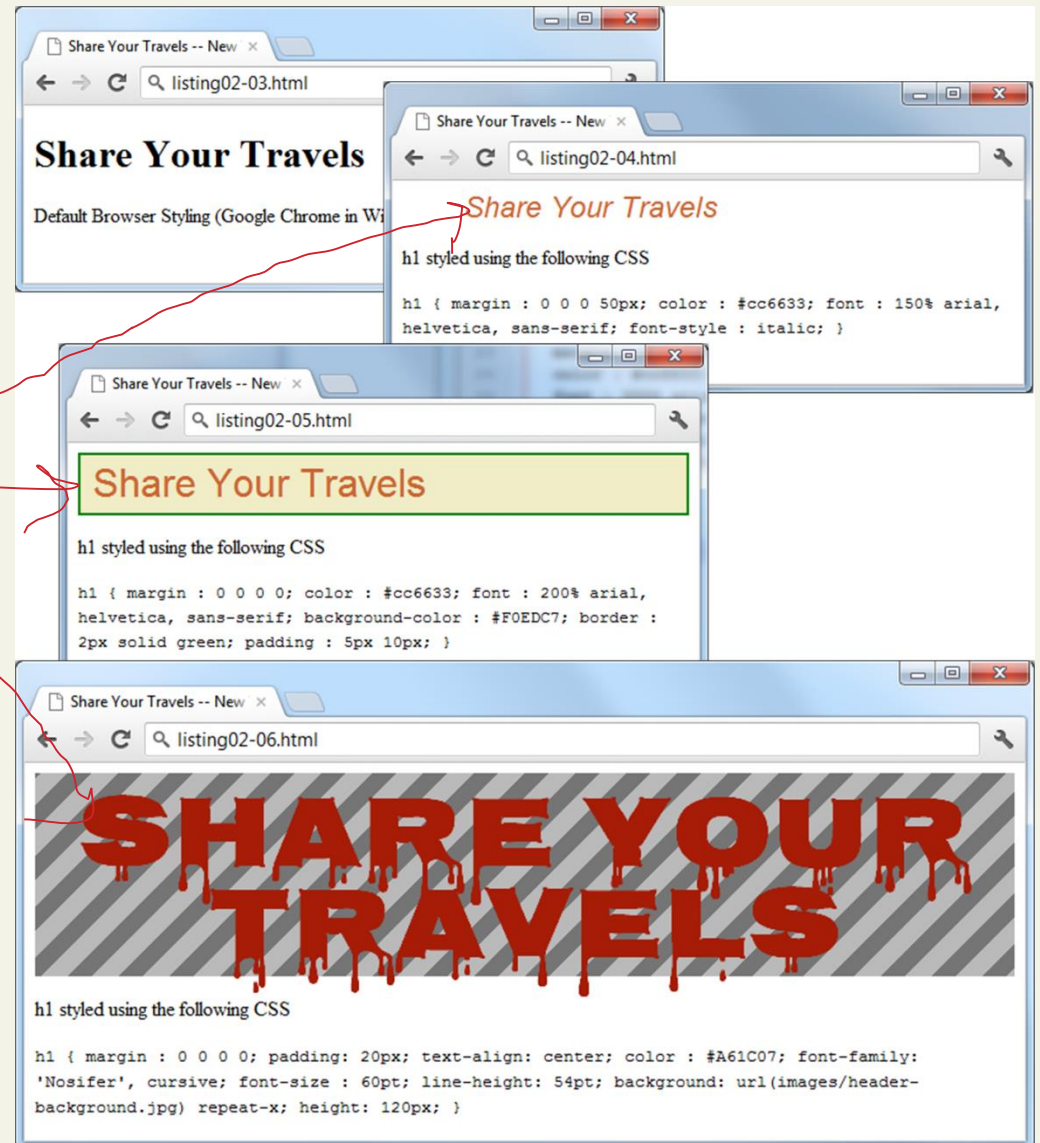

Headings

Be semantically accurate

In practice, specify a heading level that is semantically accurate.

Do not choose a heading level because of its default presentation

- e.g., choosing `<h3>` because you want your text to be bold and 16pt

Rather, choose the heading level because it is appropriate

- e.g., choosing `<h3>` because it is a third level heading and not a primary or secondary heading

2 Paragraphs

<p>

Paragraphs are the **most basic unit of text in an HTML document.**

Notice that the `<p>` tag is a container and can contain HTML and other **inline HTML elements**

inline HTML elements refers to HTML elements that do not cause a paragraph break but are part of the regular “flow” of the text.

2

```
<p>Photo by Randy Connolly</p>
<p>This photo of Conservatory Pond in
  <a href="http://www.centralpark.com/">Cen
  New York City was taken on October 22, 20
  <strong>Canon EOS 30D</strong> camera.
</p>
```

6 Divisions

<div>

This <div> tag is also a **container element** and is used to **create a logical grouping of content**

A logical grouping of content (text and other HTML elements, including containers such as <p> and other <div> elements).

To justify more than **one element as a group**, use DIV tags all elements enclosed in DIV are **formatted similarly**

```
<div style="color:#0000FF">  
  <h3>This is a heading in a div element</h3>  
  <p>This is some text in a div element.</p>  
</div>
```

This is a heading in a div element

This is some text in a div element.

3 Links

`<a>`

Links are created using the `<a>` element (the “a” stands for anchor).

A link has two main parts: the **destination** and the **label**.

```
<a href="http://www.centralpark.com">Central Park</a>
```

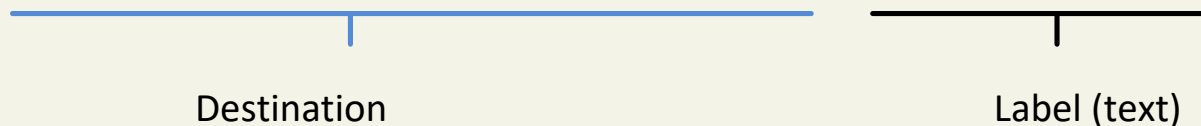

```
<a href="index.html"></a>
```



Types of Links

You can use the anchor element to create a wide range of links:

- Links to **external sites** (or to individual resources such as images or movies on an external site).
- Links to **other pages or resources within the current site**.
- Links to **other places within the current page**.
- Links to **particular locations on another page**.
- Links that are instructions to **the browser to start the user's email program**.
- Links that are instructions to **the browser to execute a Javascript function**.

Link to external site

<http://www.centralpark.com>>Central Park

Link to resource on external site

<http://www.centralpark.com/logo.gif>>Central Park

Link to another page on same site as this page

<index.html>>Home

Link to another place on the same page

<#top>>Go to Top of Document

Link to specific place on another page

<productX.html#reviews>>Reviews for product X

Link to email

<mailto://person@somewhere.com>>Someone

Link to javascript function

[javascript://OpenAnnoyingPopup\(\);](javascript://OpenAnnoyingPopup();)>See This

Link to telephone (automatically dials the number when user clicks on it using a smartphone browser)

<tel:+18009220579>>Call toll free (800) 922-0579

Different
link
destinations

Links to other places within the current page.

```
<h2 id="top">Top of page!</h2>
```

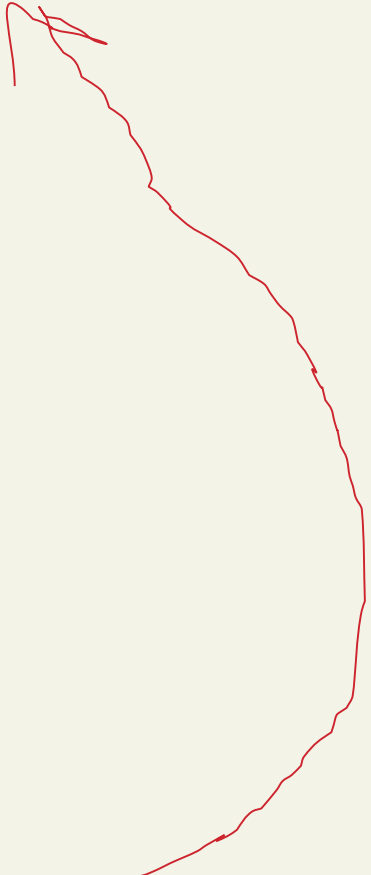

```
<a href="#top">Go to top</a>
```

Link to an element with a specified **id within a page** (the name attribute is not supported in HTML5):

```
https://www.w3schools.com/  
tags/tryit.asp?filename=tryht  
ml5\_a\_href\_anchor
```

Links to other places within the current page.

Top of page!

In my younger and more vulnerable years my father gave me some advice that I've been turning over in my mind ever since.

"Whenever you feel like criticizing any one," he told me, "just remember that all the people in this world haven't had the advantages that you've had."

```
<!DOCTYPE html>
<html>
<body>
<h2 id="top">Top of page!</h2>
```

```
<p>In my younger and more vulnerable years my father gave me some advice that I've been turning over in my mind ever since.</p>
<p>"Whenever you feel like criticizing any one," he told me, "just remember that all the people in this world haven't had the advantages that you've had."</p>
<p>He didn't say any more, but we've always been unusually communicative in a reserved way, and I understood that he meant a great deal more than that. In consequence, I'm inclined to reserve all judgments, a habit that has opened up many curious natures to me and also made me the victim of a few veteran bores. The abnormal mind is quick to detect and attach itself to this quality when it appears in a normal person, and so it came about that in college I was unjustly accused of being a politician, because I was privy to the secret griefs of wild, unknown men. Most of the confidences unsought-frequently I have feigned sleep, preoccupation, or a hostile levity when I realized by some unmistakable sign that an intimate revelation was quivering on the horizon; for the intimate revelations of young men, or at least the terms in which they express them, are usually plagiaristic and marred by obvious suppressions. Reserving judgments is a matter of infinite hope. I am still a little afraid of missing something if I forget that, as my father snobbishly suggested, and I snobbishly repeat, a sense of the fundamental decencies is parcelled out unequally at birth.</p>
<p>And, after boasting this way of my tolerance, I come to the admission that it has a limit. Conduct may be founded on the hard rock or the wet marshes, but after a certain point I don't care what it's founded on. When I came back from the East last autumn I felt that I wanted the world to be in uniform and at a sort of moral attention forever; I wanted no more riotous excursions with privileged glimpses into the human heart. Only Gatsby, the man who gives his name to this book, was exempt from my reaction-Gatsby, who represented everything for which I have an unaffected scorn. If personality is an unbroken series of successful gestures, then there was something gorgeous about him, some heightened sensitivity to the promises of life, as if he were related to one of those intricate machines that register earthquakes ten thousand miles away. This responsiveness had nothing to do with that flabby impressionability which is dignified under the name of the "creative temperament"-it was an extraordinary gift for hope, a romantic readiness such as I have never found in any other person and which it is not likely I shall ever find again. No-Gatsby turned out all right at the end; it is what preyed on Gatsby, what foul dust floated in the wake of his dreams that temporarily closed out my interest in the abortive sorrows and short-elations of men.</p>
```

```
<a href="#top">Go to top</a>
</body>
</html>
```

when it appears in a normal person, and so it came about that in college I was unjustly accused of being a politician, because I was privy to the secret griefs of wild, unknown men. Most of the confidences were unsought-frequently I have feigned sleep, preoccupation, or a hostile levity when I realized by some unmistakable sign that an intimate revelation was quivering on the horizon; for the intimate revelations of young men, or at least the terms in which they express them, are usually plagiaristic and marred by obvious suppressions. Reserving judgments is a matter of infinite hope. I am still a little afraid of missing something if I forget that, as my father snobbishly suggested, and I snobbishly repeat, a sense of the fundamental decencies is parcelled out unequally at birth.

And, after boasting this way of my tolerance, I come to the admission that it has a limit. Conduct may be founded on the hard rock or the wet marshes, but after a certain point I don't care what it's founded on. When I came back from the East last autumn I felt that I wanted the world to be in uniform and at a sort of moral attention forever; I wanted no more riotous excursions with privileged glimpses into the human heart. Only Gatsby, the man who gives his name to this book, was exempt from my reaction-Gatsby, who represented everything for which I have an unaffected scorn. If personality is an unbroken series of successful gestures, then there was something gorgeous about him, some heightened sensitivity to the promises of life, as if he were related to one of those intricate machines that register earthquakes ten thousand miles away. This responsiveness had nothing to do with that flabby impressionability which is dignified under the name of the "creative temperament"-it was an extraordinary gift for hope, a romantic readiness such as I have never found in any other person and which it is not likely I shall ever find again. No-Gatsby turned out all right at the end; it is what preyed on Gatsby, what foul dust floated in the wake of his dreams that temporarily closed out my interest in the abortive sorrows and short-winded elations of men.

[Go to top](#)

URL Absolute Referencing

For external resources

When referencing a **page or resource on an external site**, a full **absolute reference** is required: that is,

- the protocol (typically, http://),
- the domain name,
- any paths, and then finally
- the file name of the desired resource.

`http://www.funwebdev.com/index.php`

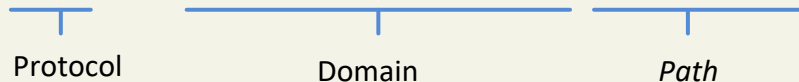
Protocol Domain Path

URL Relative Referencing

An essential skill

We also need to be able to successfully reference files within our site.

This requires learning the syntax for so-called **relative referencing**.

When referencing a resource that is on the same server as your HTML document, then you can use briefer relative referencing. **If the URL does not include the “http://” then the browser will request the current server for the file.**

URL Relative Referencing

If all the resources for the site reside within the same **directory** (also referred to as a **folder**), then you can reference those other resources simply via their filename.

However, most real-world sites contain too many files to put them all within a single directory.

For these situations, a relative pathname is required along with the filename.

The **pathname** tells the browser where to locate the file on the server.

Pathnames

Pathnames on the web follow Unix conventions.

- Forward slashes (“/”) are used to separate directory names from each other and from file names.
- Double-periods (“..”) are used to reference a directory “above” the current one in the directory tree.

URL Relative Referencing

Share-Your-Travels

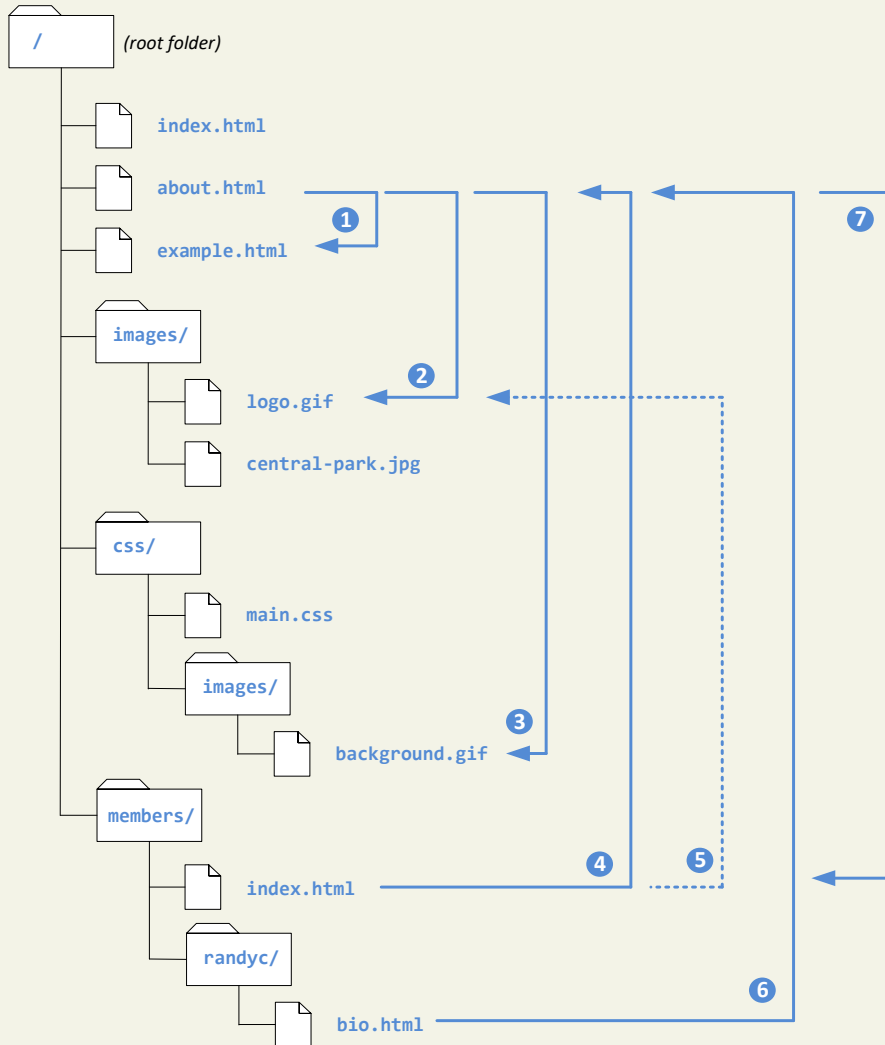

Relative Link Type	Example
1 Same Directory To link to a file within the same folder, simply use the file name.	To link to example.html from about.html (in Figure 2.18), use: <pre></pre>
2 Child Directory To link to a file within a subdirectory, use the name of the subdirectory and a slash before the file name.	To link to logo.gif from about.html , use: <pre></pre>
3 Grandchild/Descendant Directory To link to a file that is multiple subdirectories <i>below</i> the current one, construct the full path by including each subdirectory name (separated by slashes) before the file name.	To link to background.gif from about.html , use: <pre></pre>
4 Parent/Ancessor Directory Use <code>../</code> to reference a folder <i>above</i> the current one. If trying to reference a file several levels above the current one, simply string together multiple <code>../</code> .	To link to about.html from index.html in members , use: <pre></pre> To link to about.html from bio.html , use: <pre></pre>

URL Relative Referencing

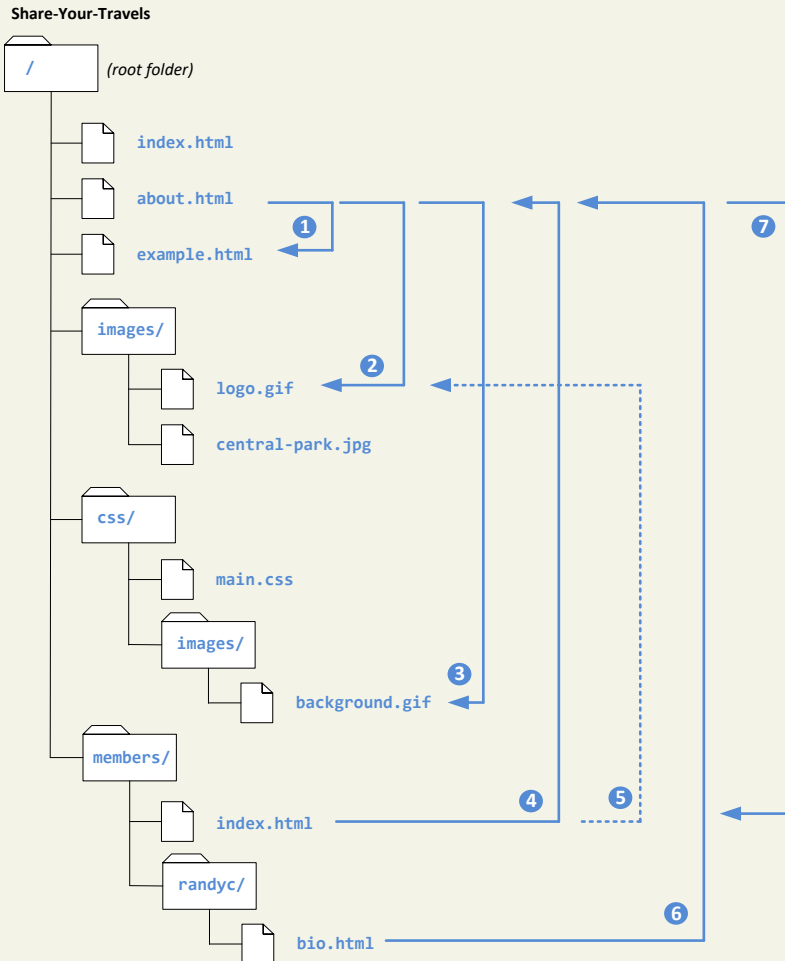

5 Sibling Directory

Use “../” to move up to the appropriate level, and then use the same technique as for child or grandchild directories.

To link to [logo.gif](#) from [index.html](#) in [members](#), use:

```
<a href="../../images/about.html">
```

To link to [background.gif](#) from [bio.html](#), use:

```
<a href="../../css/images/background.gif">
```

6 Root Reference

An alternative approach for ancestor and sibling references is to use the so-called **root reference** approach. In this approach, begin the reference with the root reference (the “/”) and then use the same technique as for child or grandchild directories. **Note that these will only work on the server! That is, they will not work when you test it out on your local machine.**

To link to [about.html](#) from [bio.html](#), use:

```
<a href="/about.html">
```

To link to [background.gif](#) from [bio.html](#), use:

```
<a href="/images/background.gif">
```

7 Default Document

Web servers allow references to directory names without file names. In such a case, the web server will serve the default document, which is usually a file called [index.html](#) (apache) or [default.html](#) (IIS). **Again, this will only generally work on the web server.**

To link to [index.html](#) in [members](#) from [about.html](#), use either:

```
<a href="members">
```

Or

```
<a href="/members">
```

Inline Text Elements

Do not disrupt the flow

Inline elements **do not disrupt the flow of text** (i.e., cause a line break).

HTML5 defines over 30 of these elements.

e.g., `<a>`, `
`, ``, ``

`<a>`, `` , `
` , `<cite>` , `<code>` , `` , `<mark>` , `<small>`

`` , `` , `<time>`

Images

Specifies the URL of the image to display
(note: uses standard relative referencing).

Text in title attribute will be displayed in a pop-up
tool tip when user moves mouse over image.

```

```

Text in alt attribute provides a brief
description of image's content for users who
are unable to see it.

Specifies the width and height of
image in pixels

Lists

Notice that the list item element can contain other HTML elements

```
<ul>  
  <li><a href="index.html">Home</a></li>  
  <li>About Us</li>  
  <li>Products</li>  
  <li>Contact Us</li>  
</ul>
```

```
<ol>  
  <li>Introduction</li>  
  <li>Background</li>  
  <li>My Solution</li>  
  <li>  
    <ol>  
      <li>Methodology</li>  
      <li>Results</li>  
      <li>Discussion</li>  
    </ol>  
  </li>  
  <li>Conclusion</li>  
</ol>
```

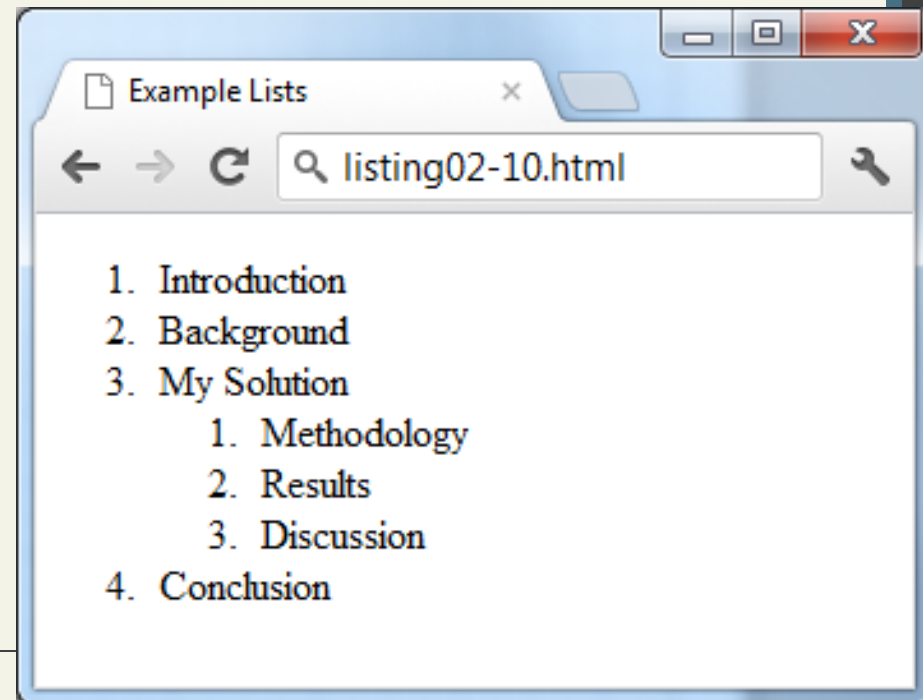
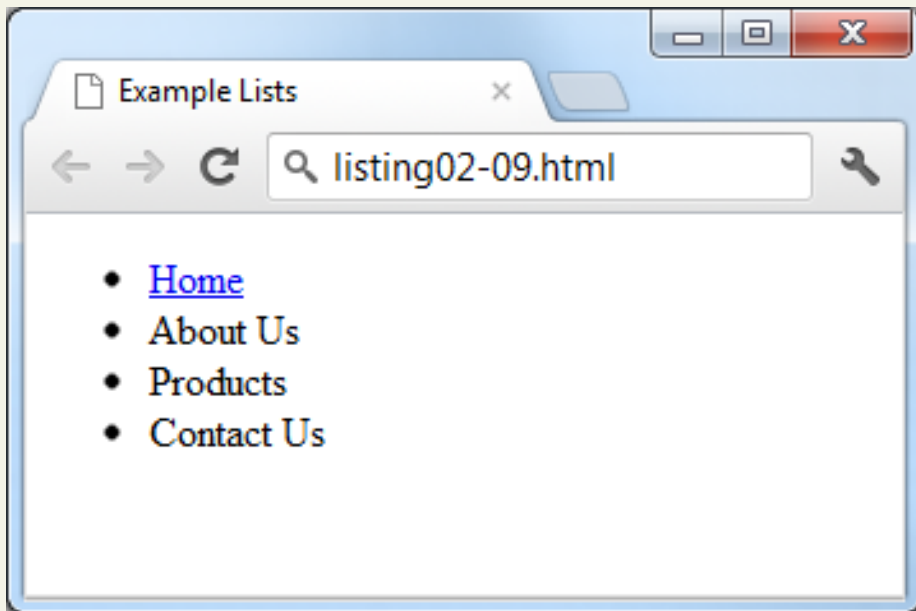

Character Entities

These are special characters for symbols for which

- there is either no easy way to type them via a keyboard
- or which have a reserved meaning in HTML (like “<”)

Entity	Description
 	Nonbreakable space
<	<
>	>
©	©
™	™

Section 6 of 6

HTML SEMANTIC ELEMENTS

HTML5 Semantic Elements

Why are they needed?

One substantial problem with modern, pre-HTML5 semantic markup:

most complex web sites are absolutely packed solid with `<div>` elements.

Unfortunately, all these `<div>` elements can make the resulting markup confusing and hard to modify.

Developers typically try to bring some sense and order to the `<div>` chaos by using **id or class names** that provide some clue as to their meaning.

HTML5 Semantic Structure Elements

Html4 Structure

div id = "header"

div id =
"menu"

div class = "post"

div class = "post"

div id = "footer"

Html5 Structure

header

nav

article

article

footer

VS

HTML5 Semantic Structure Elements

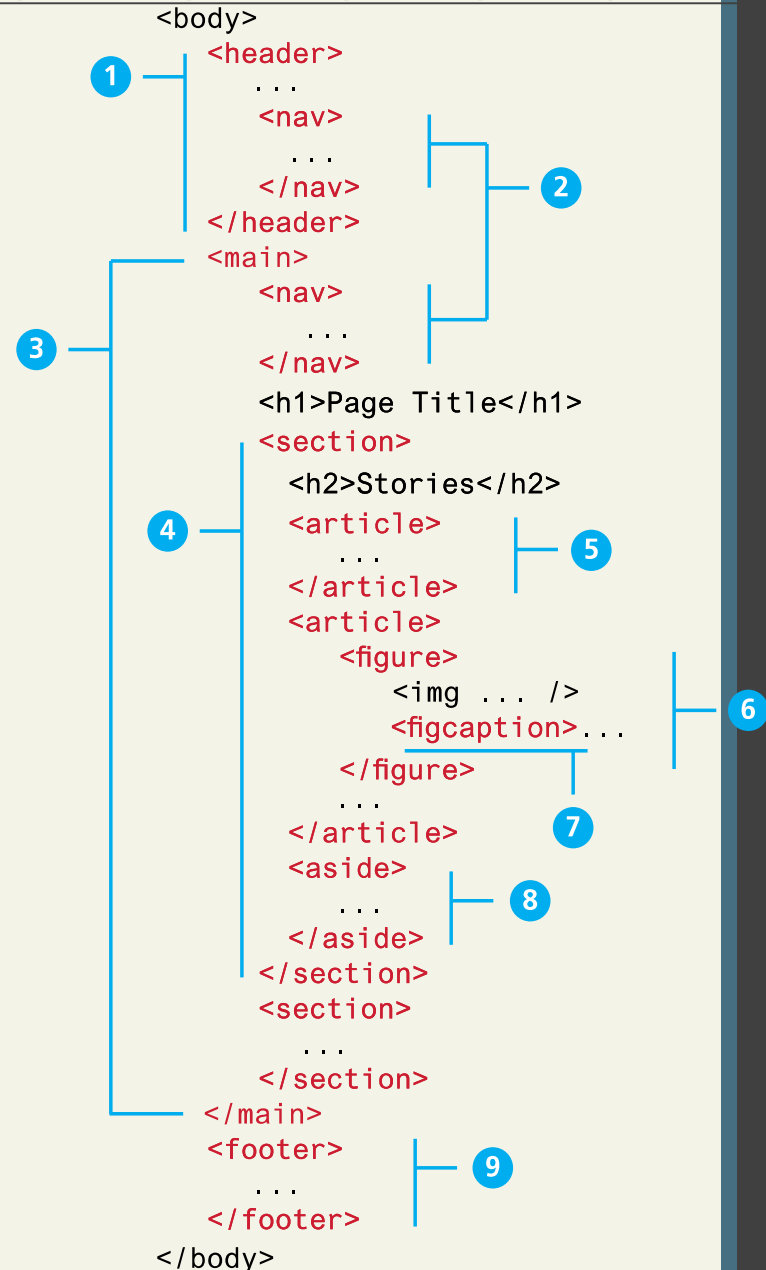
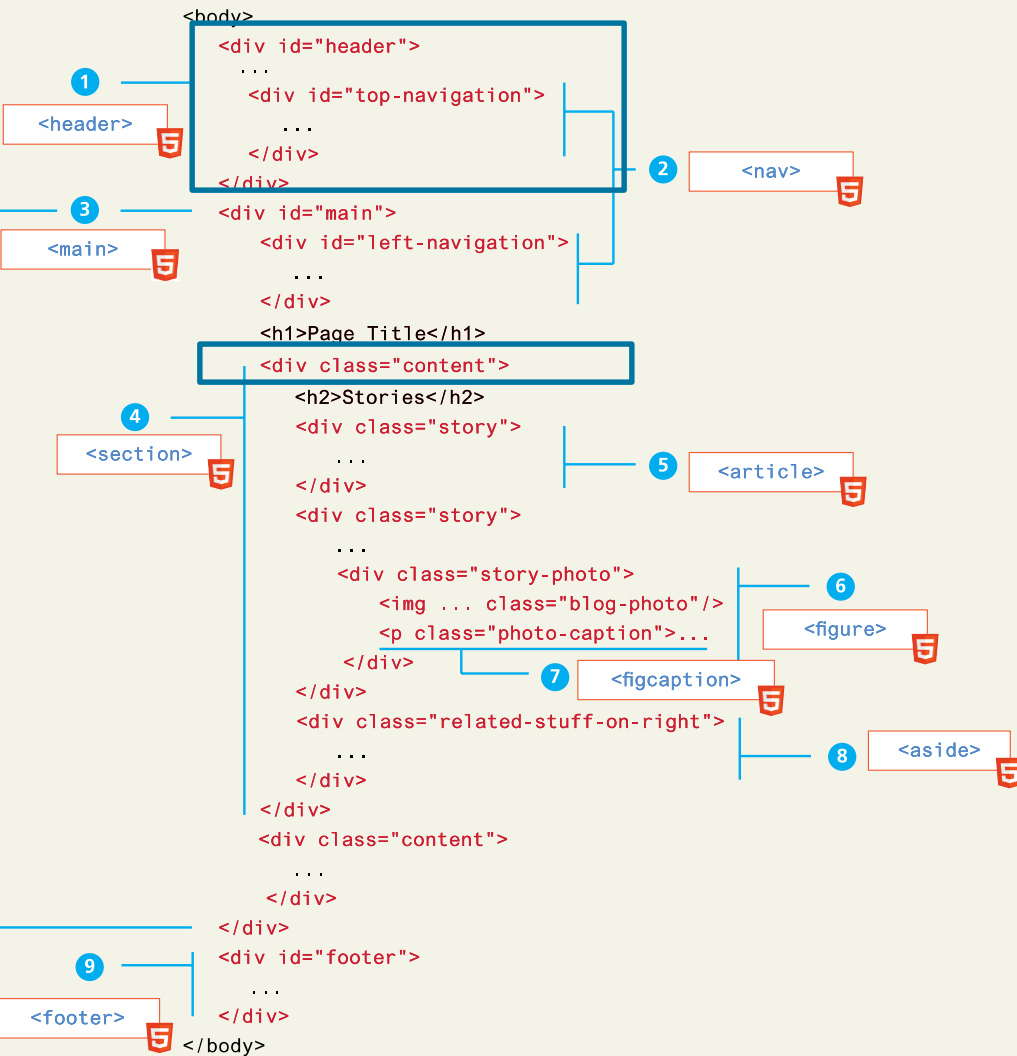

Header and Footer

<header> <footer>

Most web site pages have a recognizable **header and footer section**.

Typically the **header** contains

- the site **logo**
- **title** (and perhaps additional subtitles or taglines)
- horizontal **navigation links**, and
- perhaps one or two **horizontal banners**.

1

```
<header>
  ...
  <nav>
    ...
  </nav>
</header>
```

Smashing HTML5!

HTML5 in the year 2022-2009

home portfolio blog contact

Header and Footer

`<header>` `<footer>`

The typical footer contains less important material, such as

- **smaller text** versions of the navigation,
- **copyright** notices,
- information about the site's **privacy policy**, and
- perhaps twitter feeds or links to other **social sites**.

```
<footer>  
  . . .  
</footer>
```

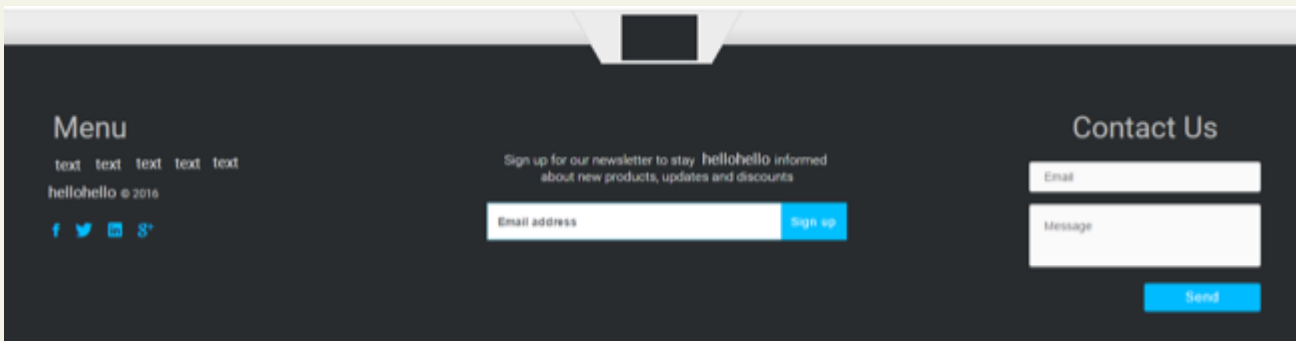

Header and Footer

`<header>` `<footer>`

`<footer>`
...
`</footer>`



9

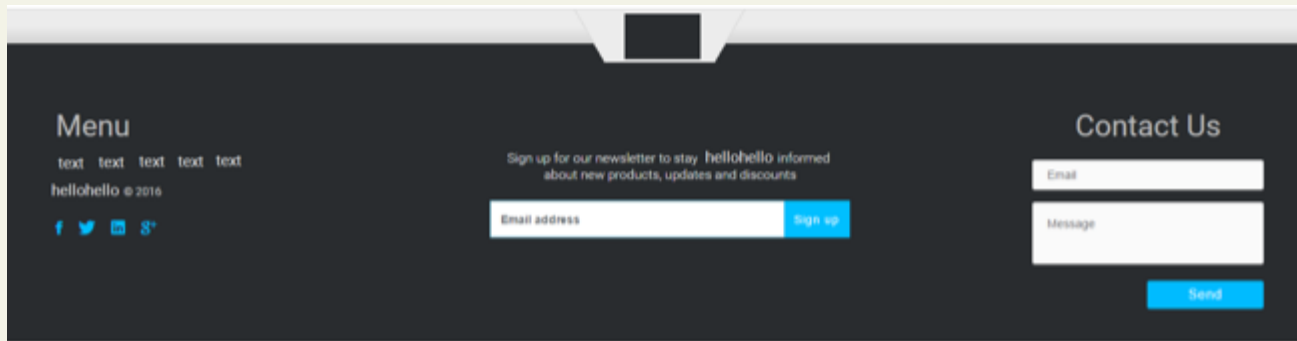

Header and Footer

Both the HTML5 `<header>` and `<footer>` element can be used **not only** for *page* headers and footers, they can also be used for header and footer elements within other HTML5 containers, such as `<article>` or `<section>`.

```
<header>
```

```
  
```

```
  <h1>Fundamentals of Web Development</h1>
```

```
  ...
```

```
</header>
```

```
<article>
```

```
  <header>
```

```
    <h2>HTML5 Semantic Structure Elements </h2>
```

```
    <p>By <em>Randy Connolly</em></p>
```

```
    <p><time>September 30, 2012</time></p>
```

```
  </header>
```

```
  ...
```

```
</article>
```

2 Heading Groups

`<hgroup>`

The `<hgroup>` element can be used to group related headings together within one container.

```
<header>
  <hgroup>
    <h1>Chapter Two: HTML 1</h1>
    <h2>An Introduction</h2>
  </hgroup>
</header>
<article>
  <hgroup>
    <h2>HTML5 Semantic Structure Elements </h2>
    <h3>Overview</h3>
  </hgroup>
</article>
```

Example:

```
<hgroup>
  <h1>Article title</h1>
  <h2>Article subtitle</h2>
</hgroup>
```

3 Navigation

<nav>

The <nav> element represents a **section of a page** that contains **links to other pages or to other parts within the same page.**

Like the other new HTML5 semantic elements, the browser does not apply any **special presentation to the <nav> element.**



3 Navigation

<nav>

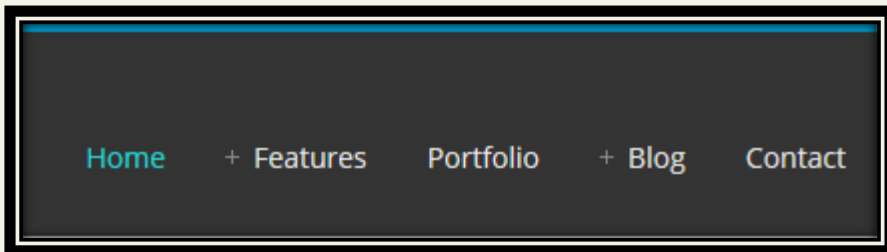
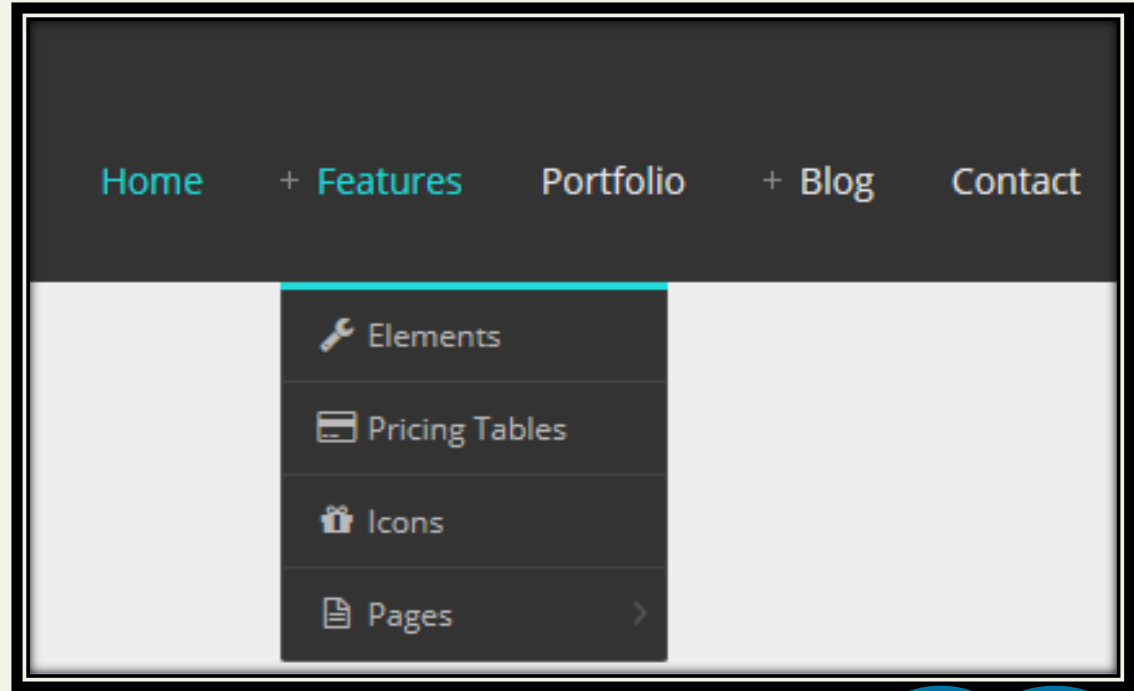
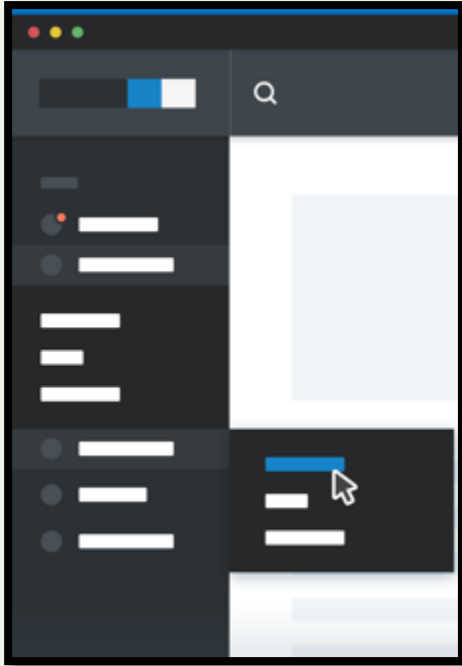

Navigation

```
<header>  
    
  <h1>Fundamentals of Web Development</h1>  
  <nav role="navigation">  
    <ul>  
      <li><a href="index.html">Home</a></li>  
      <li><a href="about.html">About Us</a></li>  
      <li><a href="browse.html">Browse</a></li>  
    </ul>  
  </nav>  
</header>
```



HTML5 Semantic Structure Elements

Main

- `<main>` is meant to contain the **main unique content of the document**.
- `<main>` provides a semantic replacement for markup such as `<div id="main">` or `<div id="main-content">`

Note: There must not be more than one `<main>` element in a document. The `<main>` element must NOT be a descendant of an `<article>`, `<aside>`, `<footer>`, `<header>`, or `<nav>` element.

Articles and Sections

`<article>` `<section>`

The `<article>` element represents a section of content that forms an independent part of a document or site; for example, **a magazine or newspaper article, or a blog entry.**

The `<section>` **element represents a section of a document, typically with a title or heading.**

Sections versus Divs

How to decide which to use

- `<section>` element is **not** a generic container element. HTML already has the `<div>` element for such uses.
- When an element is needed only for **styling purposes** or as a convenience for scripting, it makes sense to use the `<div>` element instead.

```
<section>
```

```
<h1>WWF</h1>
```

```
<p>The World Wide Fund for Nature (WWF) is an international organization working on issues regarding the conservation, research and restoration of the environment, formerly named the World Wildlife Fund. WWF was founded in 1961.</p>
```

```
</section>
```

Figure and Figure Captions

`<figure>` `<figcaption>`

The W3C Recommendation indicates that the `<figure>` element can be used not just for images but for any type of *essential* content that could be moved to a different location in the page or document and the rest of the document would still make sense.

Figure could be moved to a different location in document ...

But it has to exist in the document (i.e., the figure isn't optional).

```
<p>This photo was taken on October 22, 2011 with a Canon EOS 30D camera.</p>
<figure>
  <br/>
  <figcaption>Conservatory Pond in Central Park</figcaption>
</figure>
<p>
  It was a wonderfully beautiful autumn Sunday, with strong sunlight and expressive clouds. I was very fortunate that my one day in New York was blessed with such weather!
</p>
```



Figure and Figure Captions

Note however ...

The **<figure>** element should **not** be used to wrap every image.

For instance, it makes no sense to wrap the site logo or non-essential images such as banner ads and graphical embellishments within `<figure>` elements.

Instead, **only use the `<figure>` element for circumstances where the image (or other content) has a caption and where the figure is essential to the content but its position on the page is relatively unimportant.**

Figure and Figure Captions



```
<p>This photo was taken on October 22, 2011 with a Canon EOS 30D camera.</p>
```

```
<figure>
```

```
  <br/>
```

```
  <figcaption>Conservatory Pond in Central Park</figcaption>
```

```
</figure>
```

```
<p>
```

```
It was a wonderfully beautiful autumn Sunday, with strong sunlight and  
expressive clouds. I was very fortunate that my one day in New York was  
blessed with such weather!
```

```
</p>
```

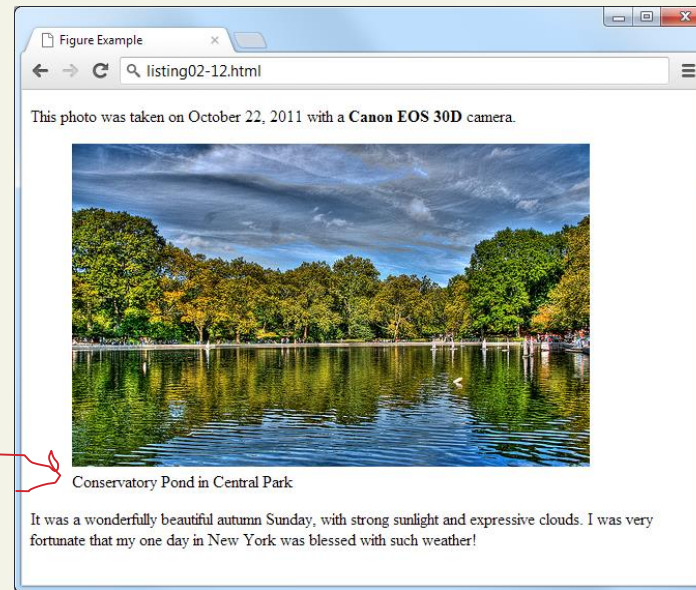

9 Aside

<aside>

The **<aside>** element could be used for sidebars, groups of advertising images, or any other grouping of non-essential elements.

```
<aside>  
  <h4>Epcot Center</h4>  
  <p>The Epcot Center is a theme park in Disney World, Florida.</p>  
</aside>
```

Epcot Center

The Epcot Center is a theme park in Disney World, Florida.

What You've Learned

1 HTML **Defined** and its **History**

2 HTML **Syntax**

3 **Semantic** Markup

4 **Structure** of HTML

5 Quick Tour of **HTML**

6 HTML **Semantic Elements**