

Interfacing Circuits

- ▶ Measurement of resistance
 - Voltage dividers
 - Wheatstone Bridge
 - Temperature compensation for strain gauges
- ▶ AC bridges
 - Measurement of capacitance
 - Measurement of impedance

Capacitors and inductors

- ▶ A capacitor is an element capable of storing charge
 - The amount of charge is proportional to the voltage across the capacitor

$$Q = CV$$

- C is known as the capacitance (measured in Farads)
- Taking derivatives

$$\frac{dQ}{dt} = \frac{d(CV)}{dt} \Rightarrow I = C \frac{dV}{dt}$$

- Therefore, a capacitor is an element whose rate of voltage change is proportional to the current through it
- ▶ Similarly, an inductor is an element whose rate of current change is proportional to the voltage applied across it

$$V = L \frac{dI}{dt}$$

- L is called the inductance and is measured in Henrys

High Pass Filter

- High pass filter

- The current through cap and resistor is

$$I = \frac{V_{in}}{Z} = \frac{V_{in}}{R + \frac{1}{j\omega C}}$$

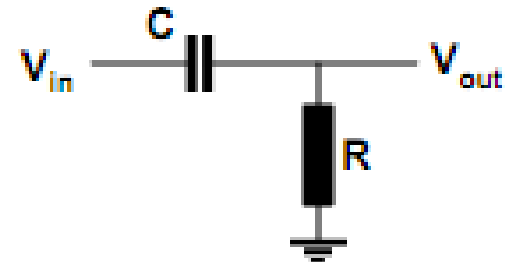

- The output voltage is equal to the voltage differential across the resistor

$$V_{out} = RI = R \frac{V_{in}}{R + \frac{1}{j\omega C}}$$

- If we focus on amplitude and ignore phase

$$|V_{out}| = R \frac{|V_{in}|}{\left| R + \frac{1}{j\omega C} \right|} = R \frac{|V_{in}|}{\sqrt{R^2 + \left(\frac{1}{\omega C} \right)^2}} = |V_{in}| \frac{\omega RC}{\sqrt{(\omega RC)^2 + 1}}$$

- Asymptotic behavior...

- Corner frequency $\omega_{CORNER} = \frac{1}{RC} \Rightarrow 20 \log_{10} \frac{|V_{out}|}{|V_{in}|} = 20 \log_{10} \frac{1}{\sqrt{1+1}} = -3.010 \text{ dB}$

Voltage divider

▶ Assumptions

- Interested in measuring the fractional change in resistance x of the sensor:
 $R_s = R_0(1+x)$
 - R_0 is the sensor resistance in the absence of a stimuli
- Load resistor expressed as $R_L = R_0 k$ for convenience

▶ The output voltage of the circuit is

$$\begin{aligned} V_{out} &= V_{CC} \frac{R_s}{R_s + R_L} = \\ &= V_{CC} \frac{R_0(1+x)}{R_0(1+x) + R_0 k} = V_{CC} \frac{1+x}{1+x+k} \end{aligned}$$

Questions

What if we reverse R_s and R_L ?

How can we recover R_s from V_{out} ?

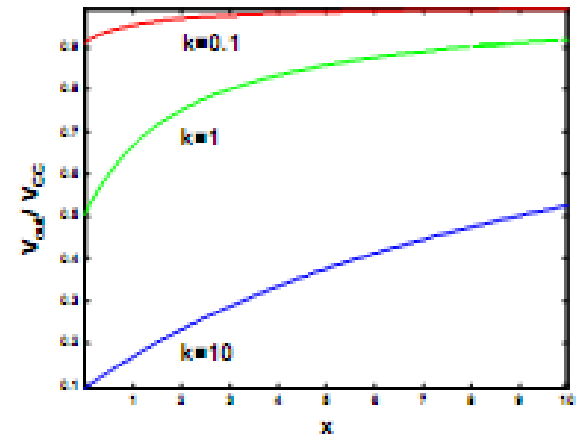
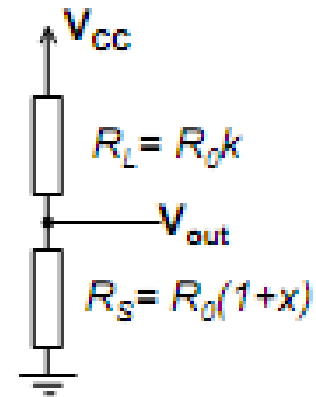

Voltage Divider

- What is the sensitivity of this circuit?

$$\begin{aligned} S &= \frac{dV_{out}}{dx} = \frac{d}{dx} \left(V_{cc} \frac{1+x}{1+x+k} \right) = \\ &= V_{cc} \frac{(1+x+k) - (1+x)}{(1+x+k)^2} = \\ &= V_{cc} \frac{k}{(1+x+k)^2} \end{aligned}$$

- For which R_L do we achieve maximum sensitivity?

$$\frac{dS}{dk} = 0 \Rightarrow \frac{d}{dk} \left(V_{cc} \frac{k}{(1+x+k)^2} \right) = 0 \Rightarrow \frac{(1+x+k)^2 - k2(1+x+k)}{(1+x+k)^2} = 0 \Rightarrow k = 1+x$$

- This is, the sensitivity is maximum when $R_L = R_S$

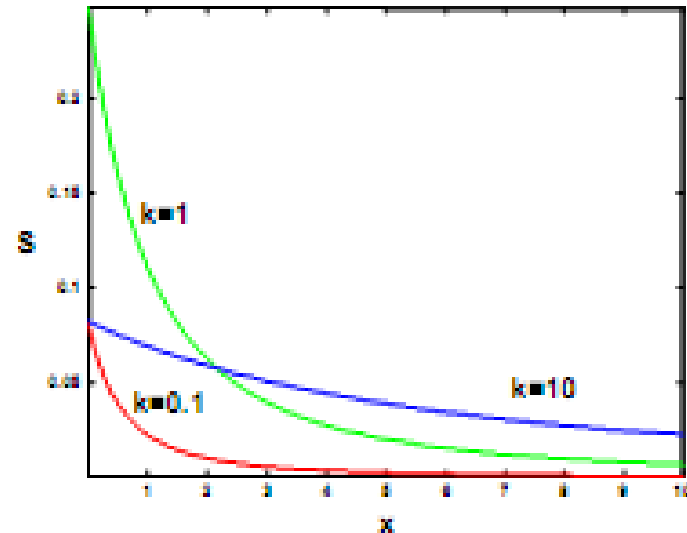

Wheatstone bridge

- A circuit that consists of two dividers

- A reference voltage divider (left)
- A sensor voltage divider

- Wheatstone bridge operating modes

- Null mode
 - R_4 adjusted until the balance condition is met:

$$V_{out} = 0 \Leftrightarrow R_3 = R_4 \frac{R_2}{R_1}$$

- Advantage: measurement is independent of fluctuations in V_{CC}

- Deflection mode

- The unbalanced voltage V_{out} is used as the output of the circuit

$$V_{out} = V_{CC} \left(\frac{R_3}{R_2 + R_3} - \frac{R_4}{R_3 + R_4} \right)$$

- Advantage: speed

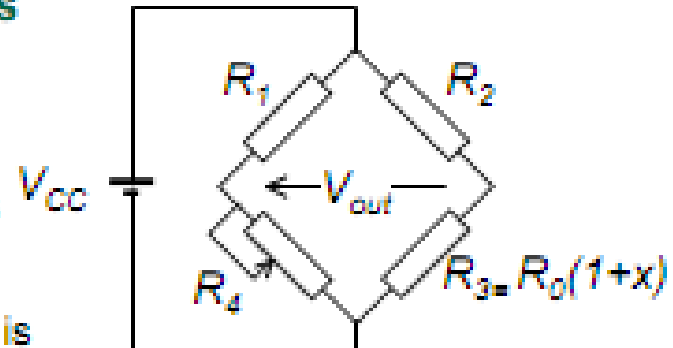

Wheatstone bridge

■ Assumptions

- Want to measure sensor fractional resistance changes $R_S = R_0(1+x)$
- Bridge is operating near the balance condition:

$$k = \frac{R_1}{R_4} = \frac{R_2}{R_0}$$

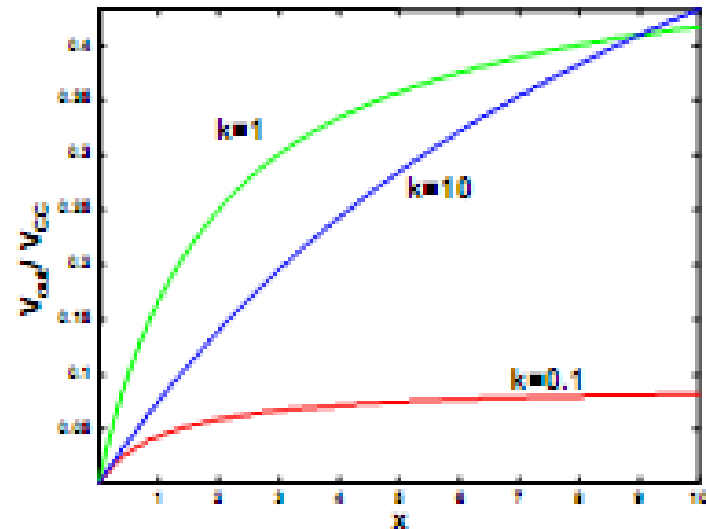

■ The output voltage becomes

$$\begin{aligned} V_{out} &= V_{CC} \left(\frac{R_0(1+x)}{R_0k + R_0(1+x)} - \frac{R_4}{R_4k + R_4} \right) = \\ &= V_{CC} \left(\frac{(1+x)}{k + (1+x)} - \frac{1}{k+1} \right) = V_{CC} \frac{kx}{(1+k)(1+k+x)} \end{aligned}$$

- ▶ What is the sensitivity of the Wheatstone bridge?

$$\begin{aligned} S &= \frac{dV_{out}}{dx} = V_{cc} \frac{d}{dx} \left(\frac{kx}{(1+k)(1+k+x)} \right) = \\ &= V_{cc} \frac{k(1+k)(1+k+x) - kx(1+k)}{(1+k)^2(1+k+x)^2} = \\ &= V_{cc} \frac{k}{(1+k+x)^2} \end{aligned}$$

- ❑ The sensitivity of the Wheatstone bridge is the same as that of a voltage divider
 - You can think of the Wheatstone bridge as a DC offset removal circuit
- ❑ So what are the advantages, if any, of the Wheatstone bridge?

Voltage divider vs. Wheatstone for small x

- ▶ The figures below show the output of both circuits for small fractional resistance changes
 - The voltage divider has a large DC offset compared to the voltage swing, which makes the curves look “flat” (zero sensitivity)
 - Imagine measuring the height of a person standing on top of a tall building by running a large tape measure from the street
- ▶ The sensitivity of both circuits is the same!
 - However, the Wheatstone bridge sensitivity can be boosted with a gain stage
 - Assuming that our DAQ hardware dynamic range is 0–5VDC, $0 < x < 0.01$ and $k=1$, estimate the maximum gain that could be applied to each circuit

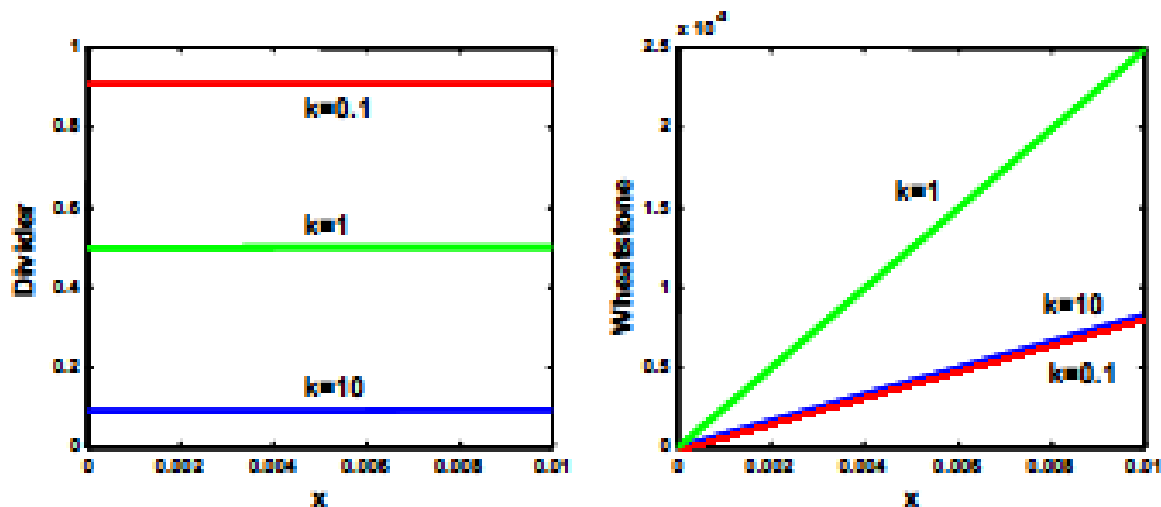

Compensation in a Wheatstone bridge

- ▶ Strain gauges are quite sensitive to temperature
 - A Wheatstone bridge and a dummy strain gauge may be used to compensate for this effect
 - The “active” gauge R_A is subject to temperature (x) and strain (y) stimuli
 - The dummy gauge R_D , placed near the “active” gauge, is only subject to temperature
 - The gauges are arranged according to the figures below
 - The effect of $(1 + y)$ on the right divider cancels out

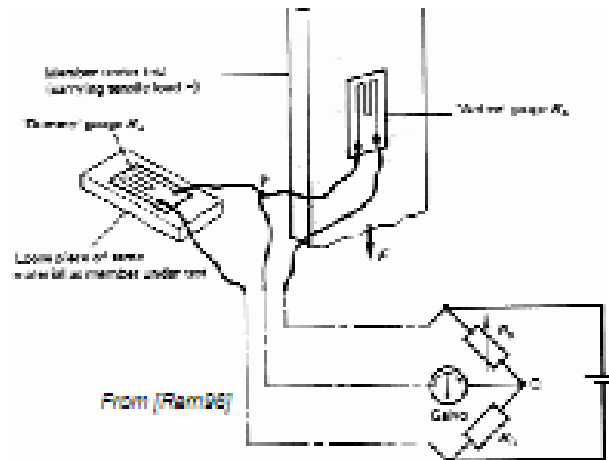
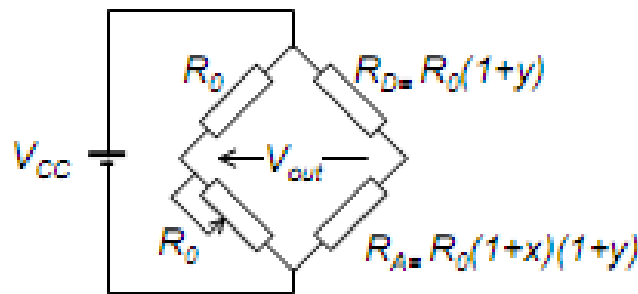

AC bridges

- **The structure of the Wheatstone bridge can be used to measure capacitive and inductive sensors**

- Resistance replaced by generalized impedance
- DC bridge excitation replaced by an AC source

- **The balance condition becomes**

$$\frac{Z_1}{Z_4} = \frac{Z_2}{Z_3}$$

- which yields two equalities, for real and imaginary components

$$R_1 R_3 - X_1 X_3 = R_2 R_4 - X_2 X_4$$

$$R_1 X_3 + X_1 R_3 = R_2 X_4 + X_2 R_4$$

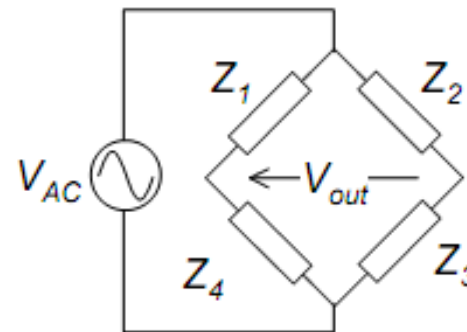

- **There is a large number of AC bridge arrangements**

- These are named after their respective developer

DIODES

A diode is the electronic equivalent of a hydraulic check valve:

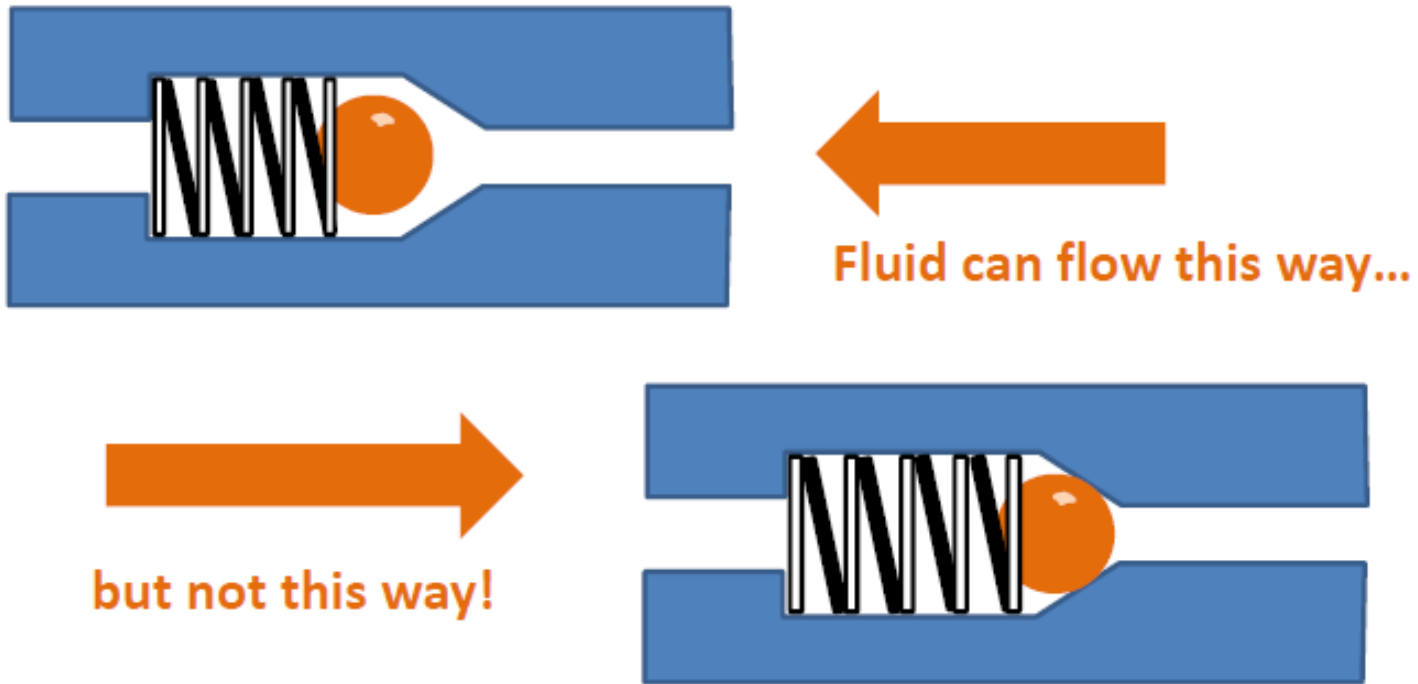

AC Bridges

■ Capacitance measurement

- Schering bridge
- Wien bridge

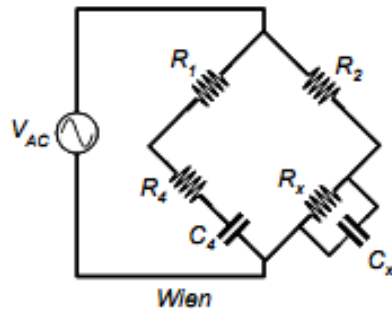
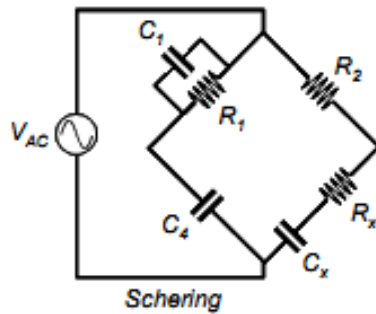

■ Inductance measurement

- Hay bridge
- Owen bridge

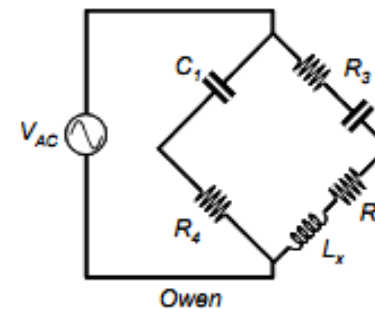
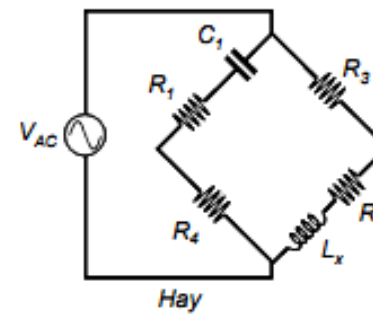

DIODES

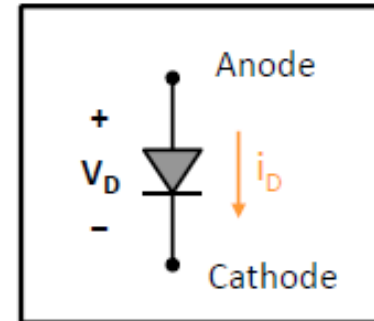

Approximation:

- Forward Bias:

If $V_D > V_Y$ ($\sim 0.6-0.7$ V)

⇒ Diode conducts (short circuit)

- Reverse Bias:

If $V_Z < V_D < V_Y$

⇒ Diode does not conduct (open circuit)

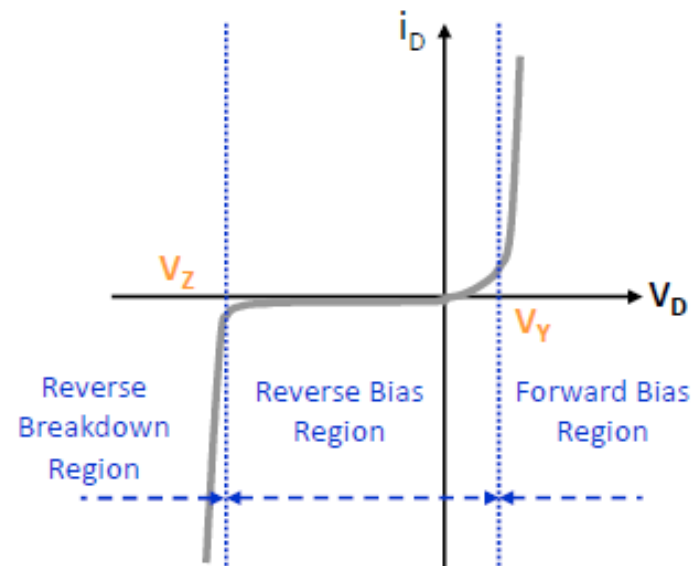

If you exceed the breakdown voltage, you will likely destroy the diode!

DIODES: PRACTICAL CONSIDERATIONS

When a diode is forward biased, if the voltage across the diode is larger than V_Y then the diode can be modeled as a short circuit in series with a V_Y volt battery, e.g.

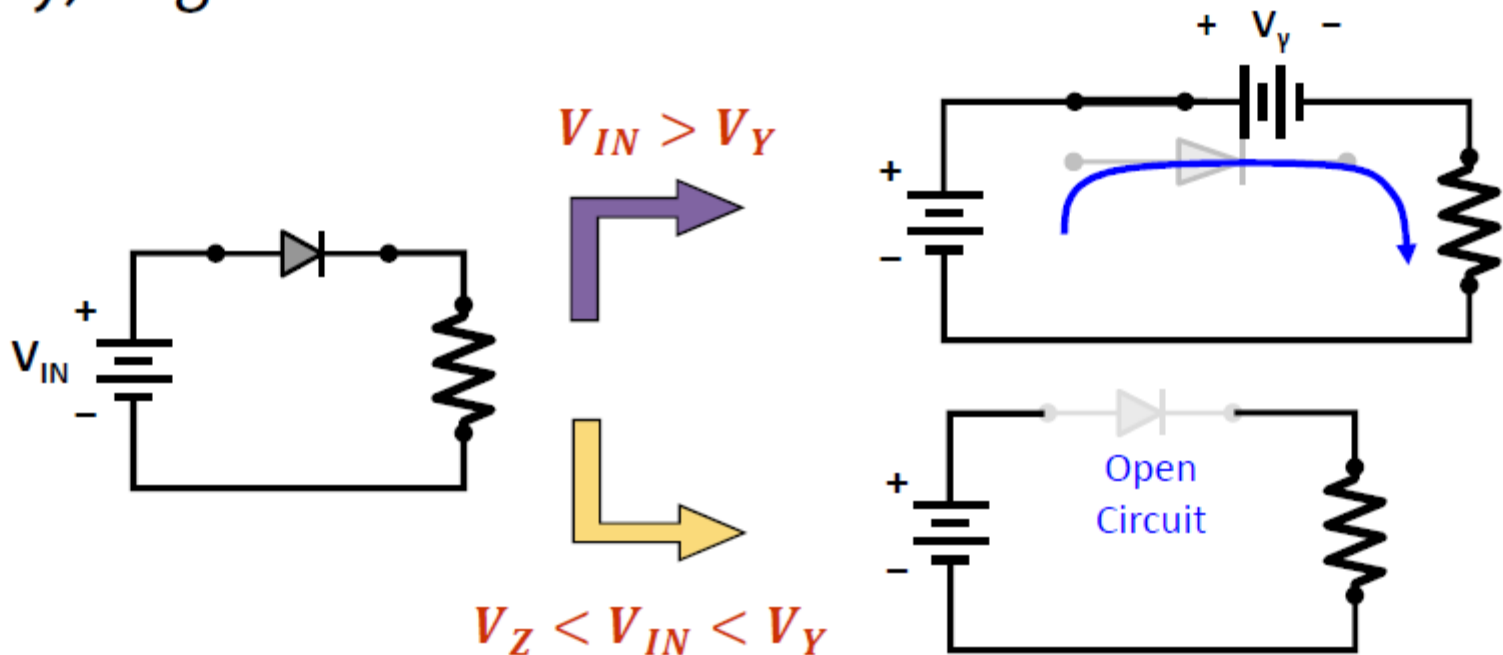

PRACTICAL CONSIDERATIONS

In addition to watching out for the maximum permissible reverse bias voltage, one has to ensure that the maximum allowable current (I_0) is not exceeded. Placing a *current limiting* resistor in series with the diode takes care of this problem.

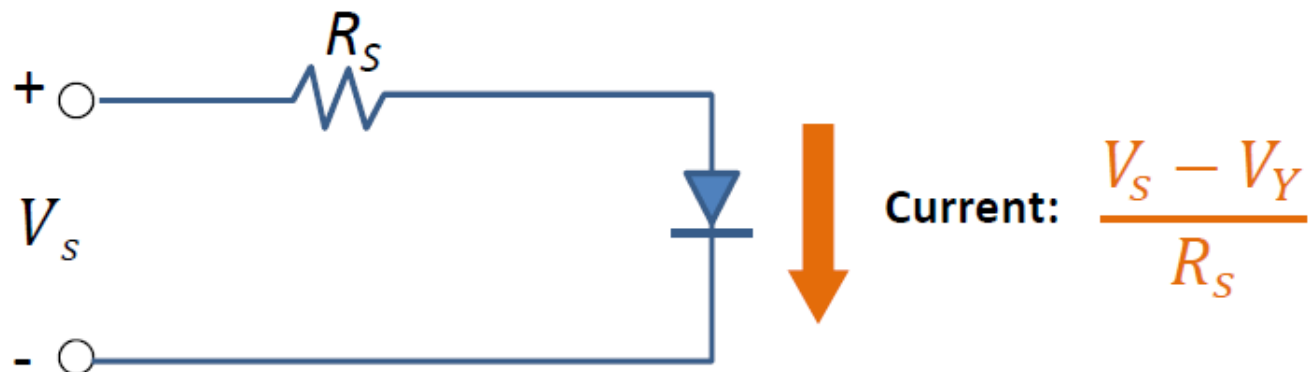

DIODE APPLICATION: RECTIFICATION

Rectification of AC Signals

- Half-wave rectifier

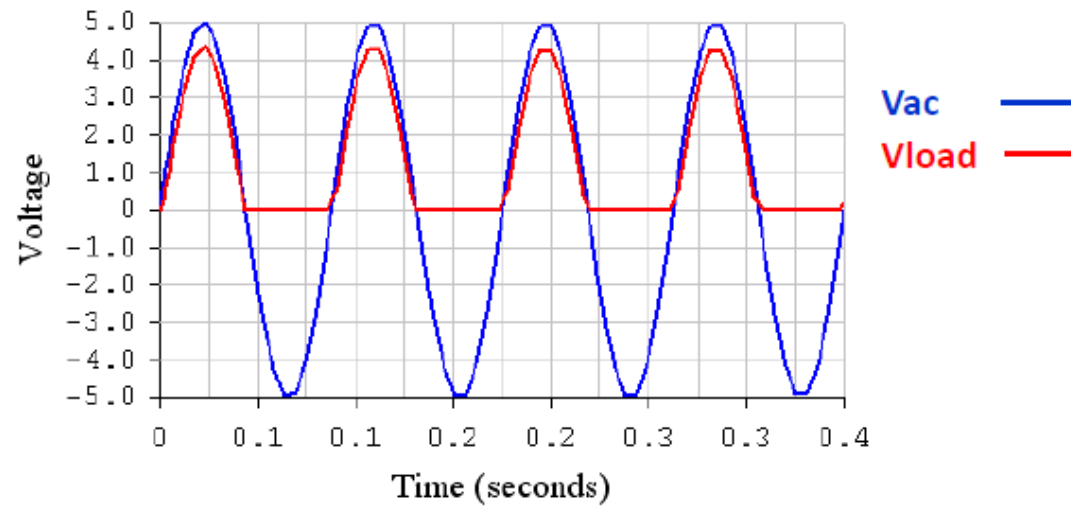
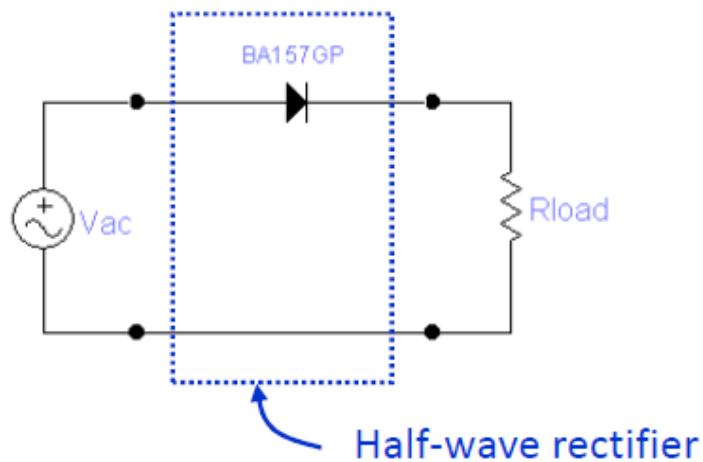

DIODE APPLICATION: RECTIFICATION

Rectification of AC Signals

- Bridge rectifier

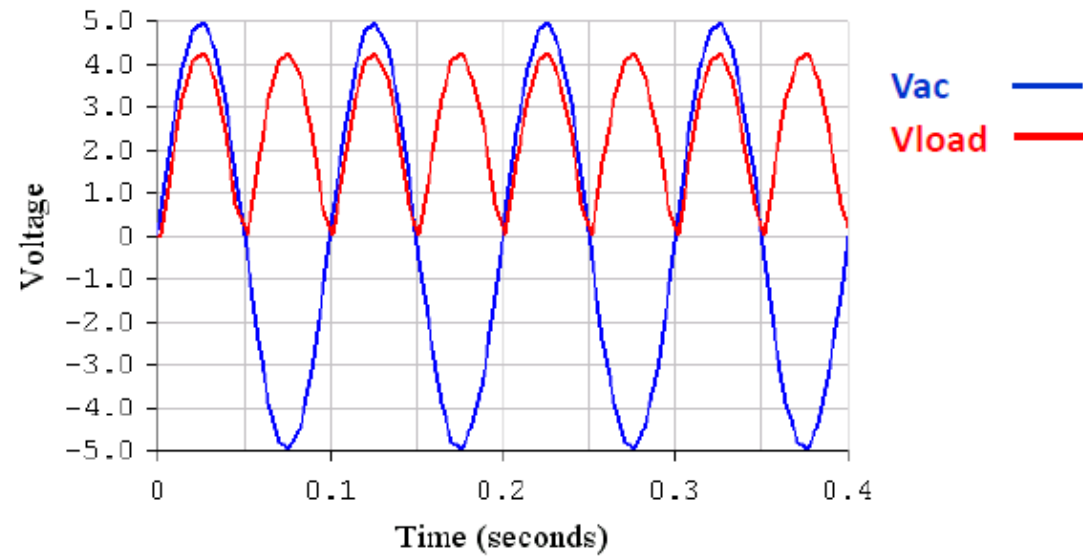
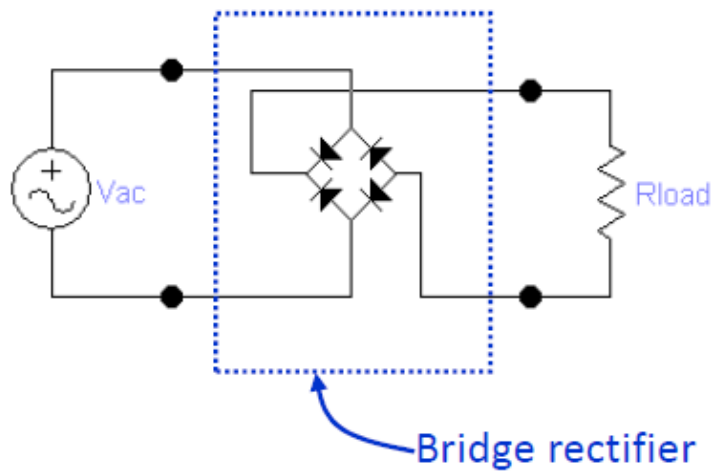

DC POWER SUPPLY

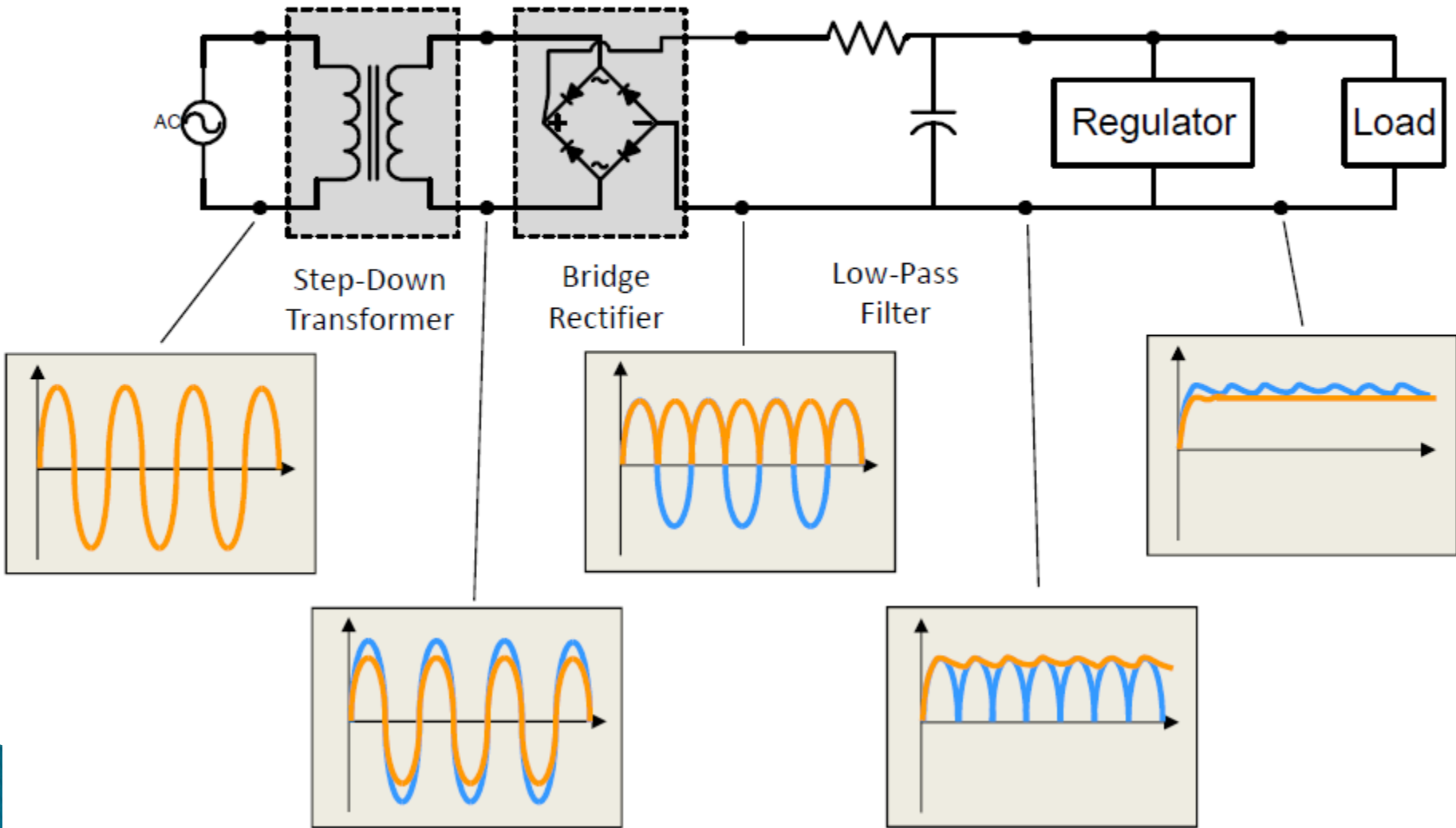

OTHER DIODE APPLICATIONS

Diode Peak Detector

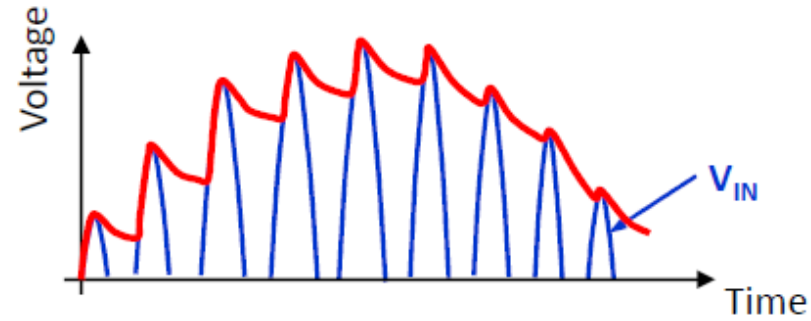
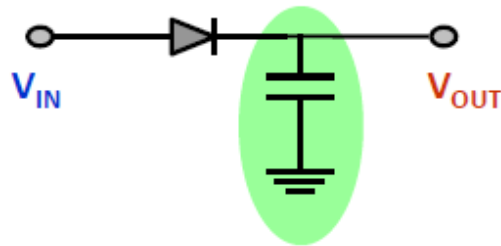

Diode Limiter

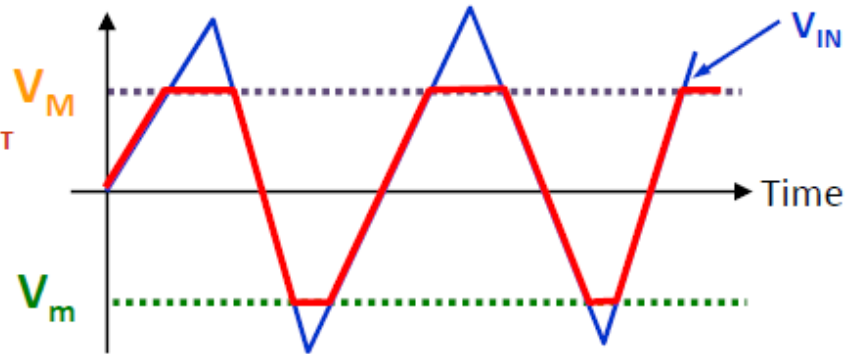
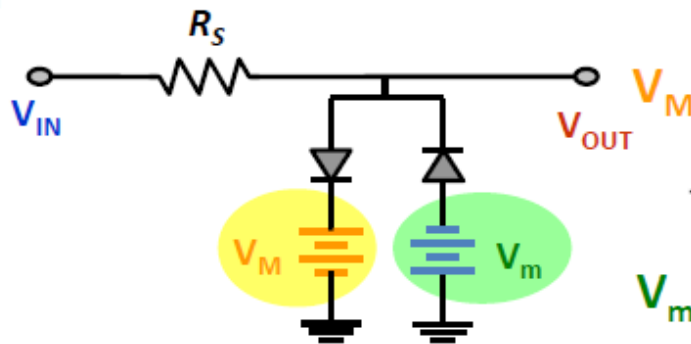

Bias Diode Clamp

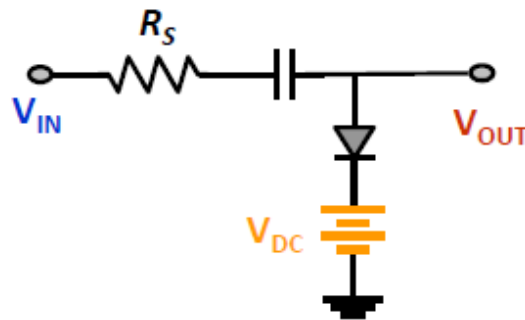

$$V_{OUT} = V_{IN} - V_{PEAK} + V_{DC}$$

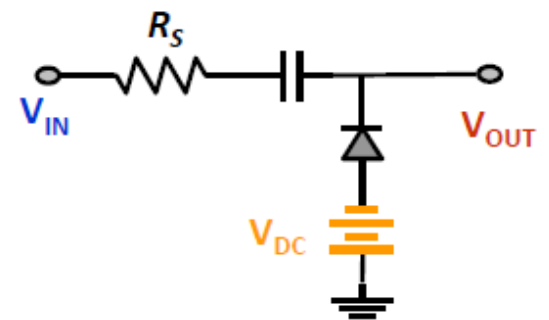

$$V_{OUT} = V_{IN} + V_{PEAK} - V_{DC}$$

ZENER DIODES

A special-purpose diode that operates in the reverse breakdown region

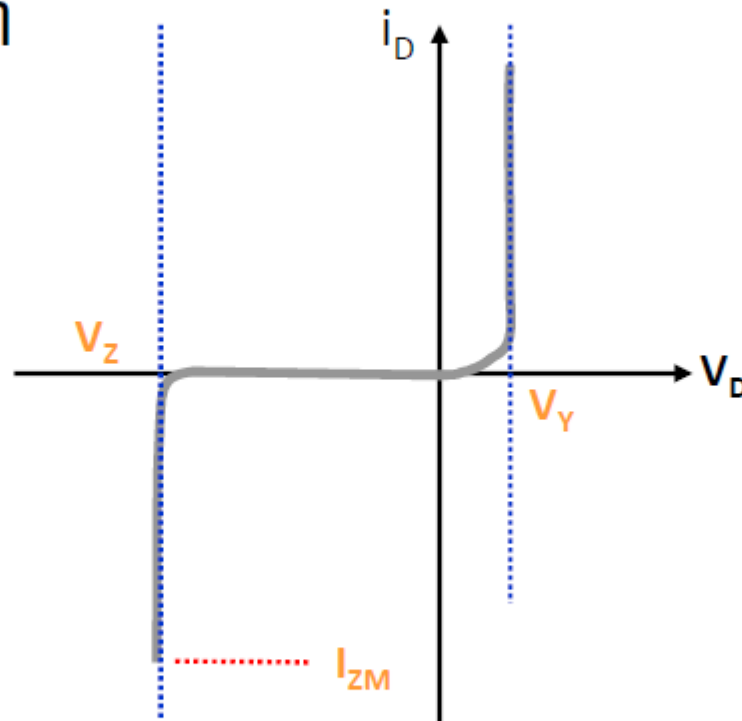

Exhibits steep breakdown curve with well defined breakdown voltage V_Z ; can maintain nearly constant voltage for a wide range of currents

ZENER DIODES

A zener diode can be modeled as a device having two parallel branches:

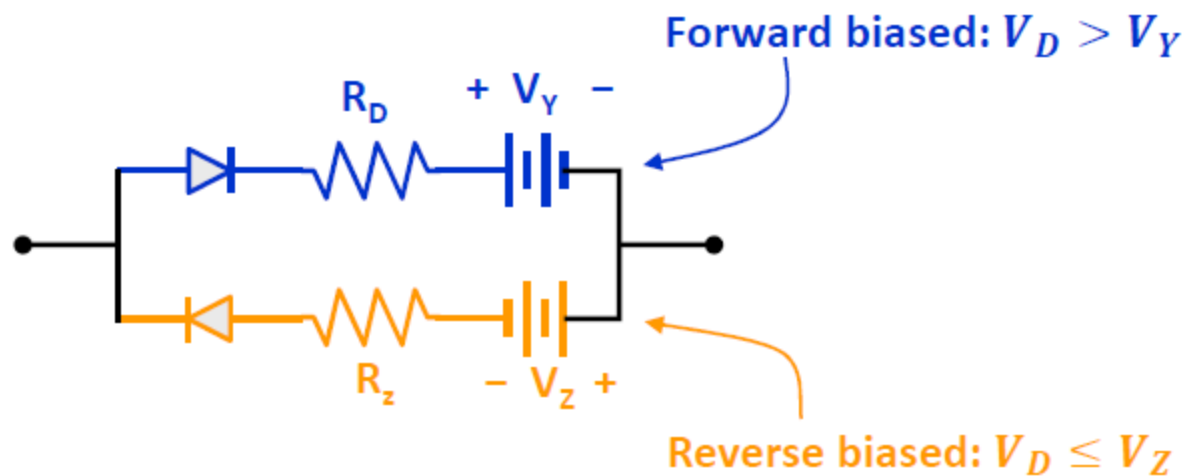
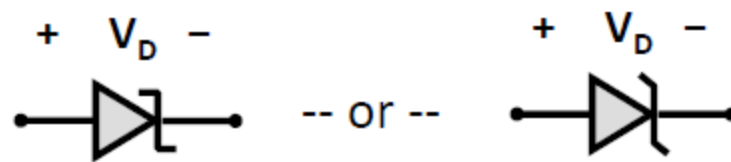

ZENER DIODE APPLICATION: VOLTAGE REGULATOR

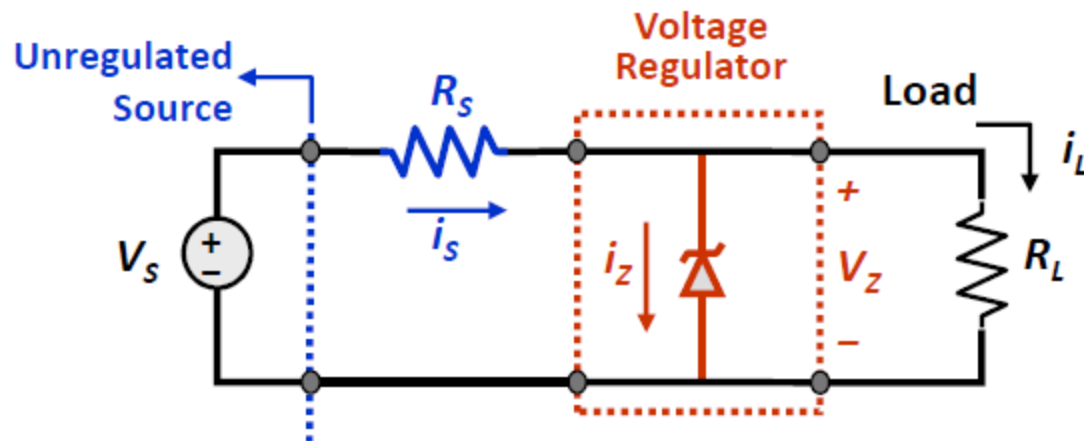

- Load voltage equals V_Z if the Zener diode is in the reverse breakdown region: $i_L = \frac{V_Z}{R_L}$
- Load current comes from KCL: $i_L = i_S - i_Z$
- Source current is: $i_S = \frac{V_S - V_Z}{R_S}$
- Zener diode is usually rated by its maximum allowable power dissipation: $P_{Z,max} = i_{Z,max} \cdot V_Z$

VOLTAGE REGULATION: PRACTICAL CONSIDERATION

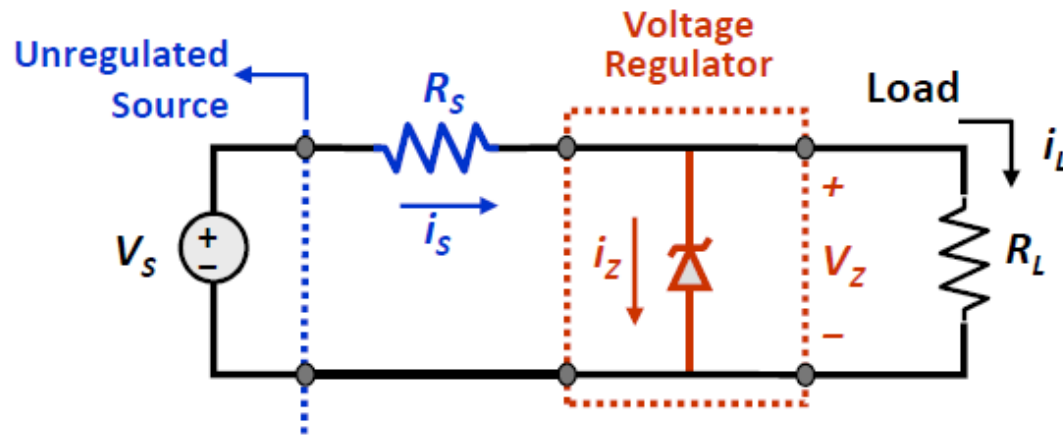

Source voltage ripple is lowered by a factor of $\frac{R_s}{R_z}$ at the load, assuming the load resistance remains constant. Thus, to reduce voltage ripple by a factor of 100, select R_s so that $R_s = 100 R_z$

VOLTAGE REGULATION:

PRACTICAL CONSIDERATION

Zener regulators are usually smaller, cheaper, and easier to implement, and are suitable for low power voltage regulation. However, IC voltage regulators are generally more efficient, especially for widely varying current loads, and at higher power levels.

- Zener diode performance changes with temperature, while IC voltage regulators are compensated for thermal variations.
 - Since the zener diode splits current with the load, the voltage drop across the zener diode can be influenced by the load current. In comparison, an IC voltage regulator is designed to draw a nearly constant bias current, regardless of fluctuations in load voltage and current.
- 

LIGHT-EMITTING DIODES

LEDs are diodes that emits photons when forward biased. The intensity of the light is related to the amount of current flowing through the diode

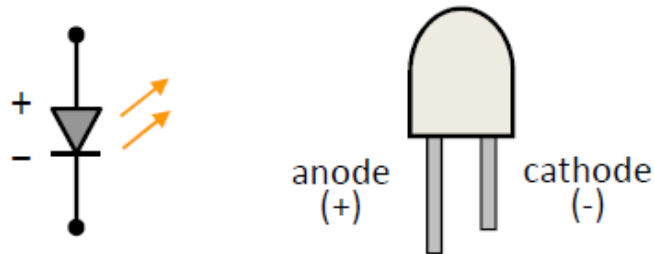

LIGHT-EMITTING DIODES

LEDs exhibit a voltage drop of 1.5 to 2.5 volts when forward biased

A series current-limiting resistor ($\sim 330\Omega$ for a 5 volt source) is needed to prevent excess forward current

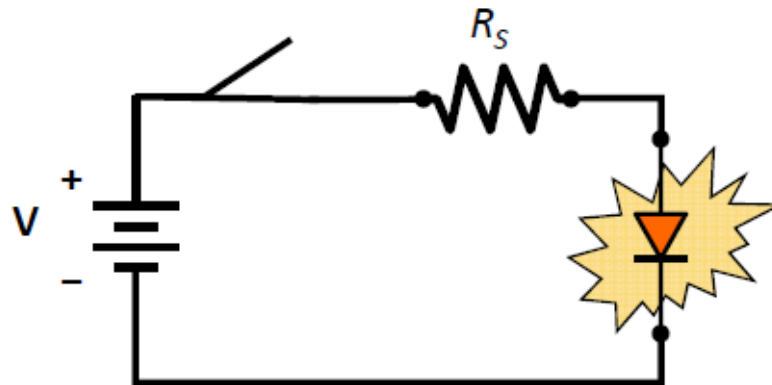

PHOTODIODES

Light sensitive $p-n$ junctions are called *photodiodes*

Such devices are optimized to generate reverse (leakage) current in the presence of light. As the light intensity increases, additional electrons are kicked into the conduction band, allowing for greater current flow.

A photodiode can be used as a light sensor



OPTOCOUPPLERS

Uses the current-to-light and light-to-current conversion properties of LED and photodiode to couple two circuits while maintaining electronic isolation

- Extremely useful when connecting high-power circuits to low-power control circuits
- Not suited for analog signals

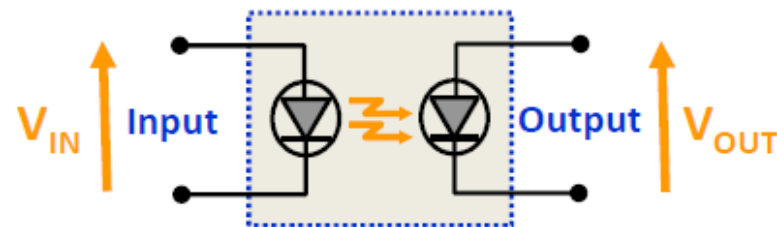

SCHOTTKY DIODES

At high frequencies ($> 1\text{MHz}$), ordinary diodes cannot shut off quick enough to avoid noticeable current. This is corrected by a Schottky diode, which uses a precious metal on one side of the p - n junction, and doped silicon on the other.

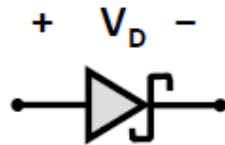

ELECTRO-MECHANICAL RELAY SWITCH

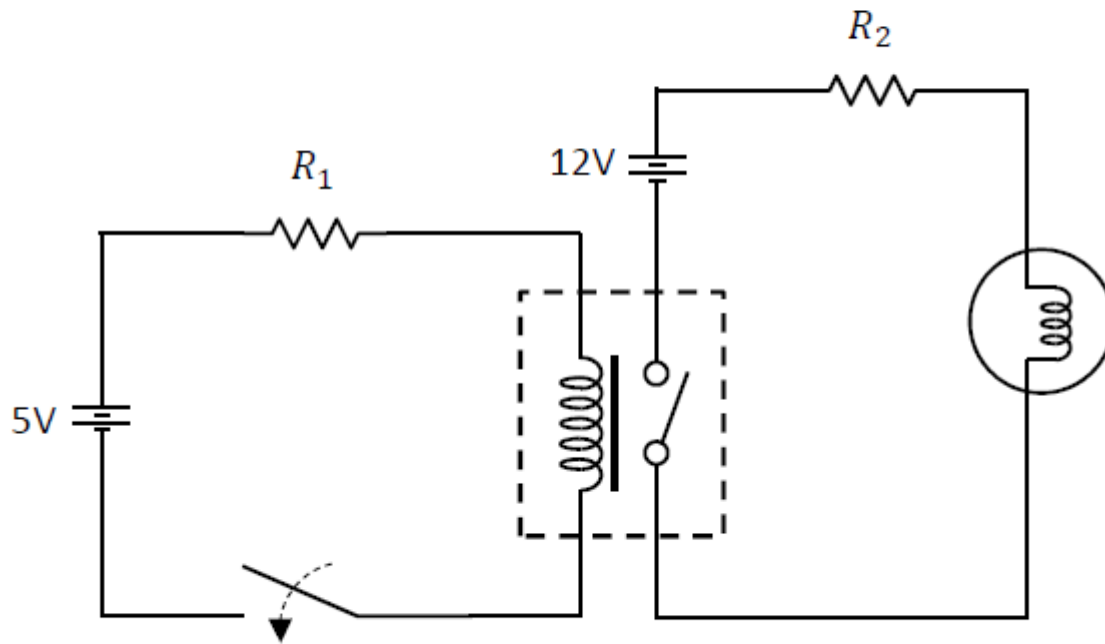

SPST

ELECTRO-MECHANICAL RELAY SWITCH

Pros:

- Inexpensive
- Large selection
- When properly sized, can handle high currents and voltages
- Resistant to electrical surges

Cons:

- Bulky
- Prone to "sticking" or mechanical fatigue
- Slow (5 to 15 msec) switching time
- Limited cycle rate
- Substantial current needed to pull in relay

ELECTRONIC SWITCHING

As we will see, transistors can be made to behave as switches in a wide variety of applications.

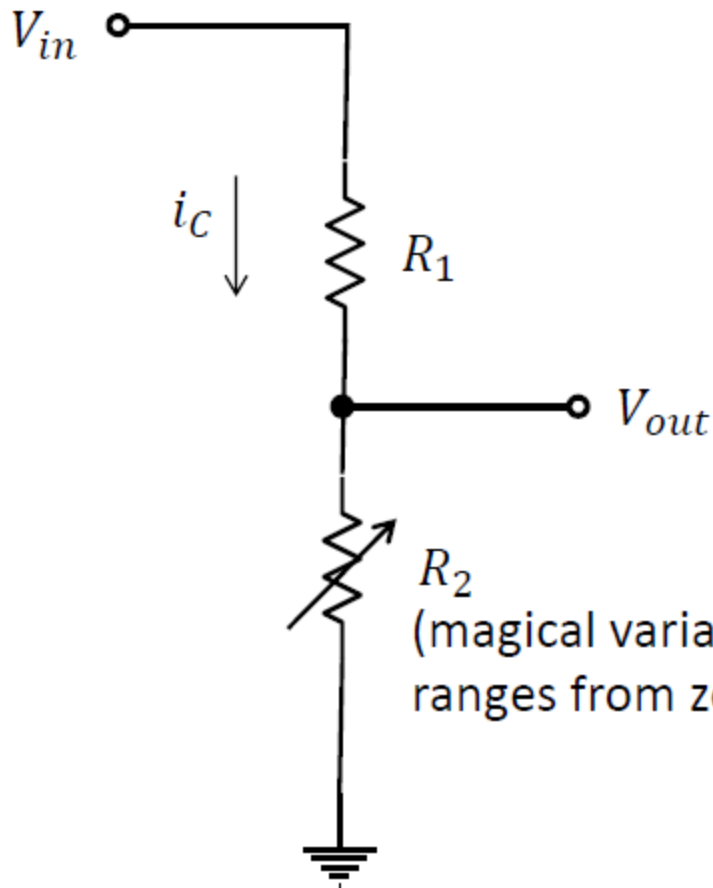

$$V_{out} = \frac{R_2}{R_1 + R_2} V_{in}$$

VOLTAGE DIVIDER

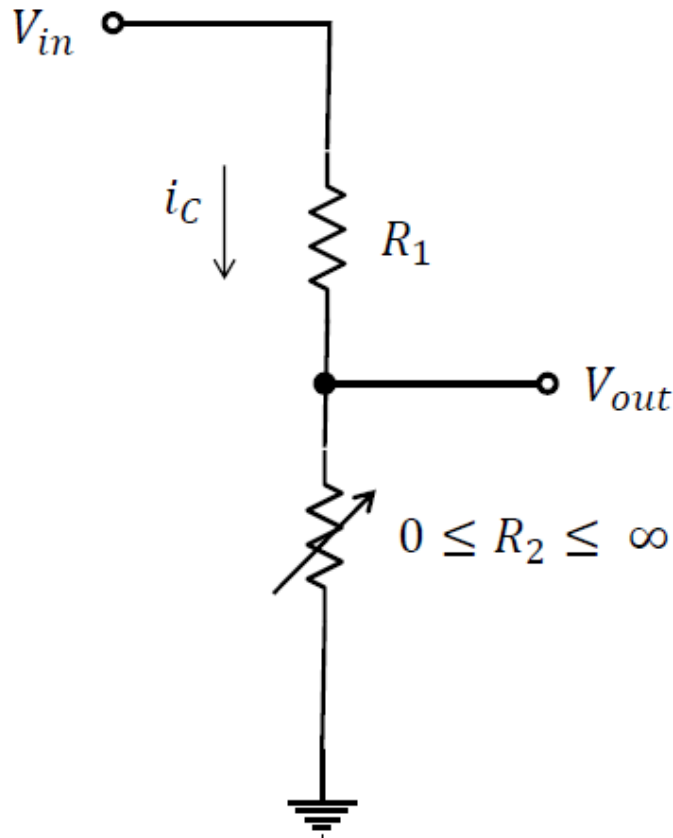

$$V_{out} = \frac{R_2}{R_1 + R_2} V_{in}$$

$$V_{out} = V_{in} - i_C R_1$$

V_{out} is dependent on i_C ,
which in turn is controlled
by adjustments to R_2

VOLTAGE DIVIDER

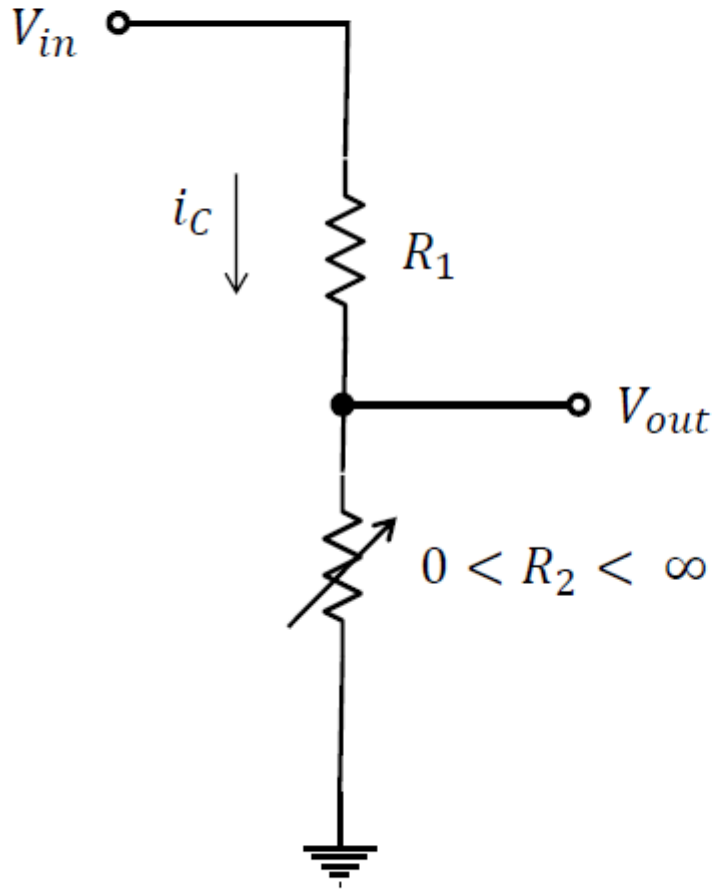

$$V_{out} = \frac{R_2}{R_1 + R_2} V_{in}$$

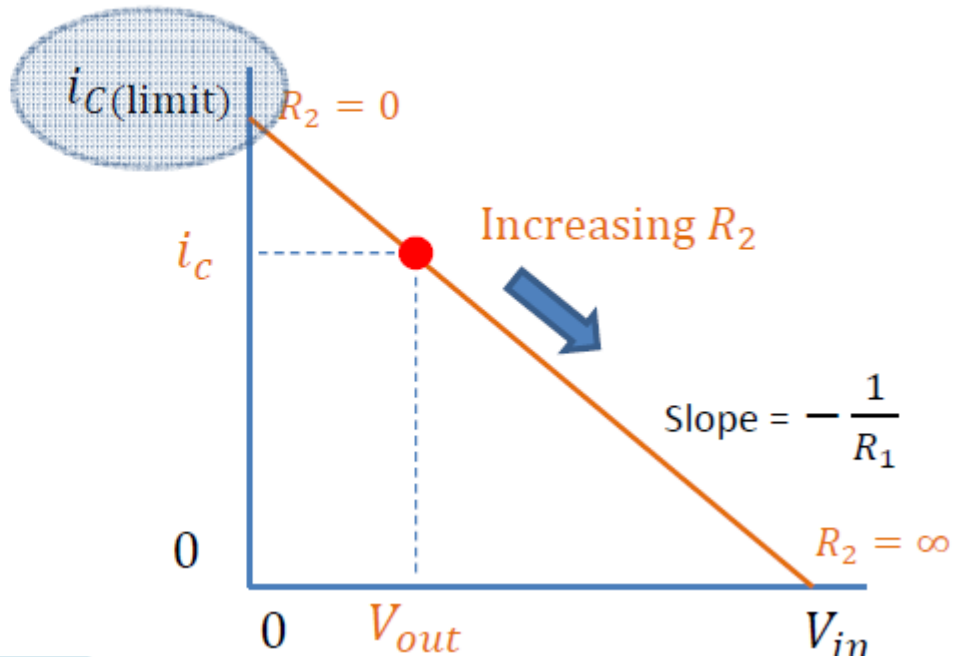

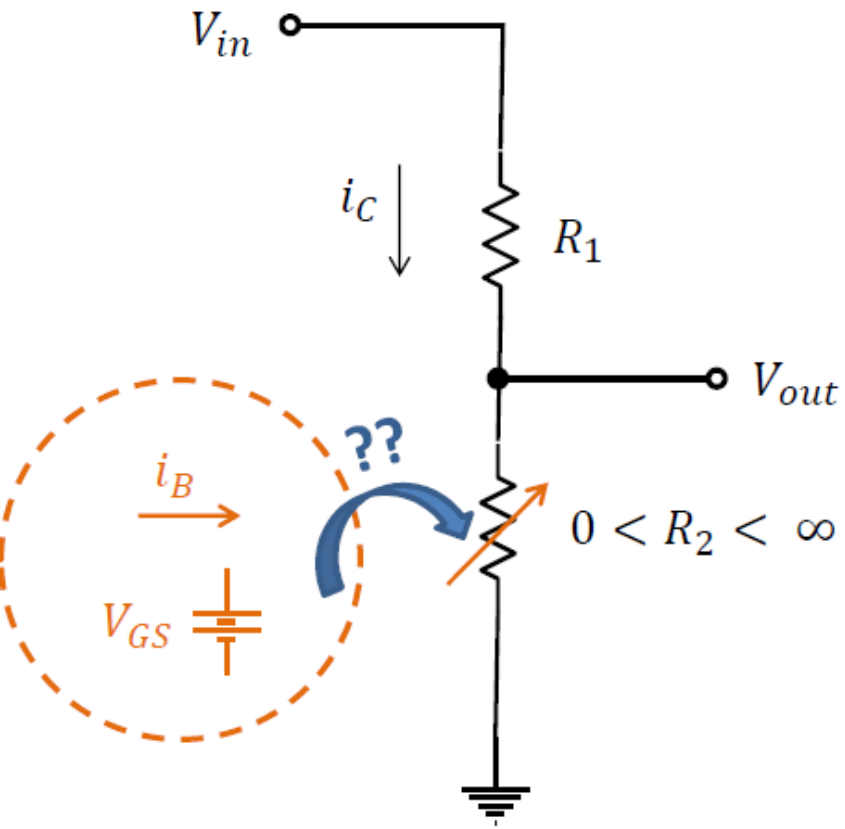

$$V_{out} = \frac{R_2}{R_1 + R_2} V_{in}$$

$$V_{out} = V_{in} - (i_B \beta) R_1$$

What if we could control i_C with a small input signal?

VOLTAGE DIVIDER

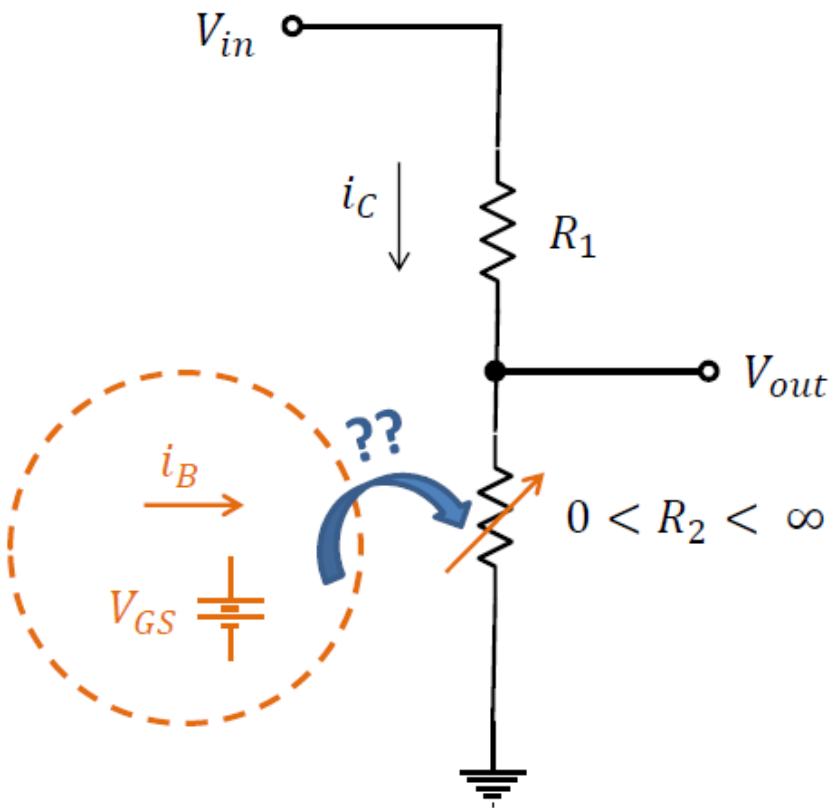

What if we could control i_C with a small input signal?

$$V_{out} = \frac{R_2}{R_1 + R_2} V_{in}$$

$$V_{out} = V_{in} - (i_B \beta) R_1$$

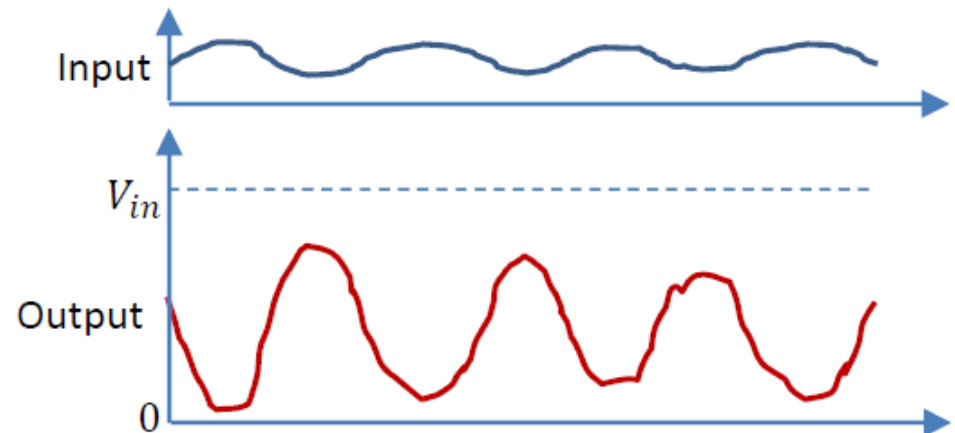

VOLTAGE DIVIDER

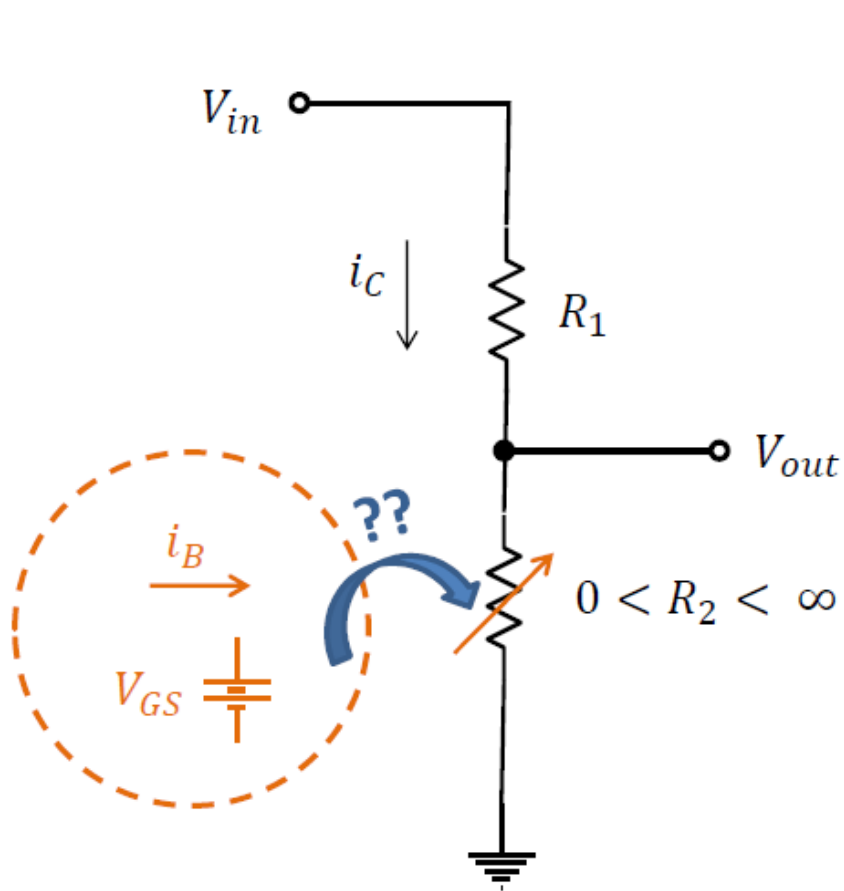

What if we could control i_c with a small input signal?

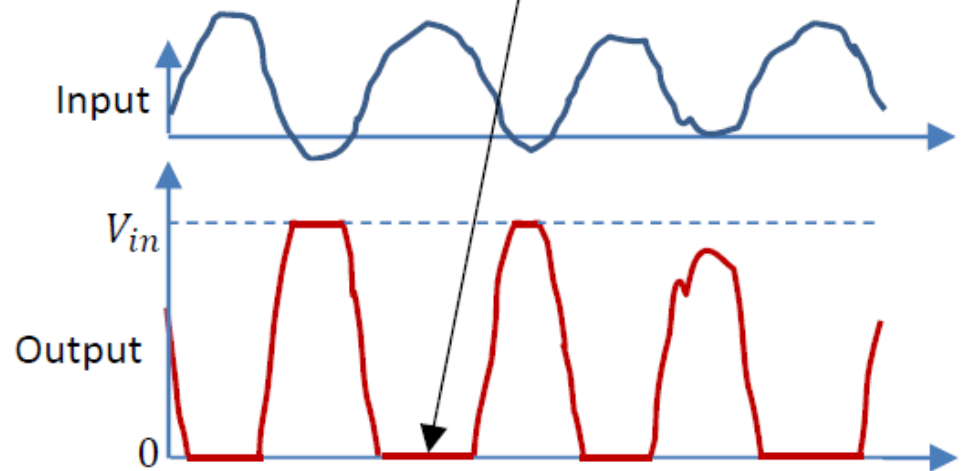
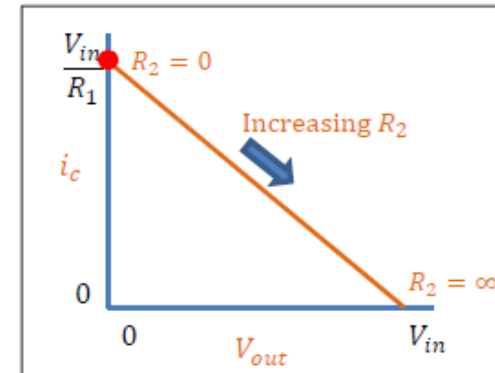

VOLTAGE DIVIDER

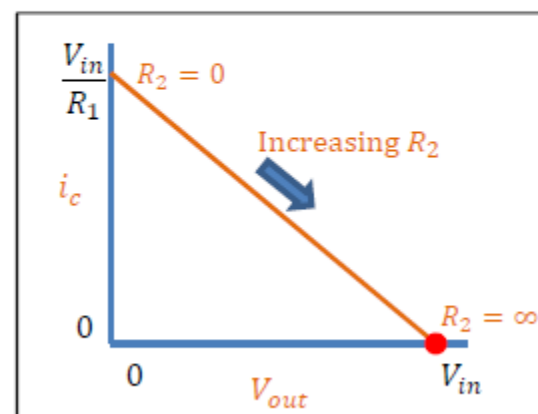
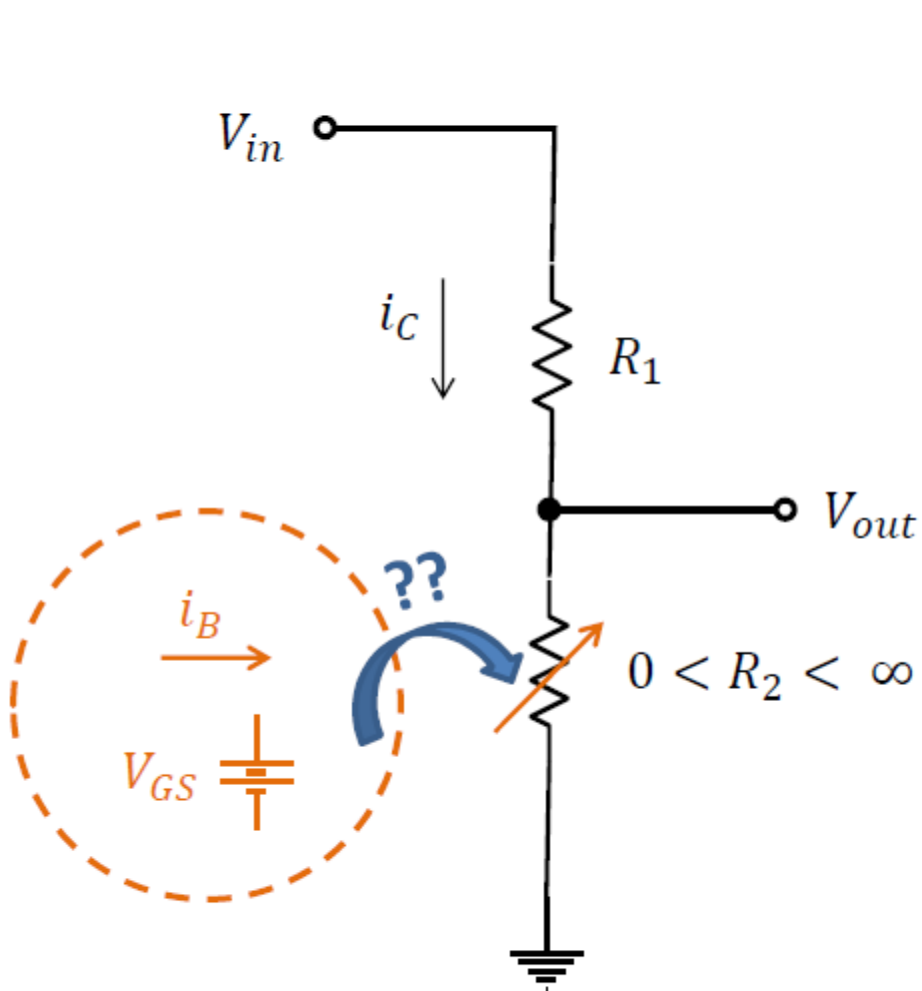

What if we could control i_C with a small input signal?

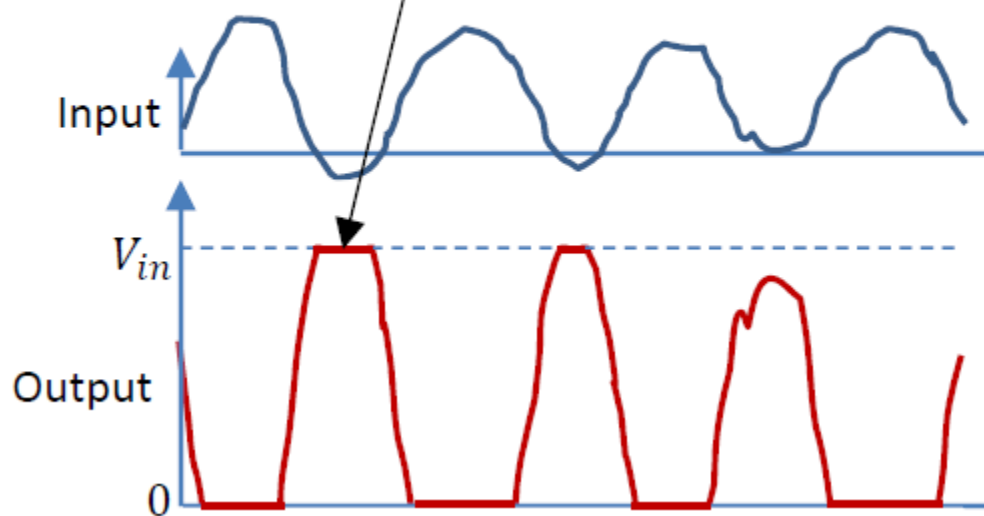

TRANSISTORS

Magical variable resistor is called a transistor!

TRANSISTORS

Three-terminal semiconductor devices capable of performing two fundamental operations:

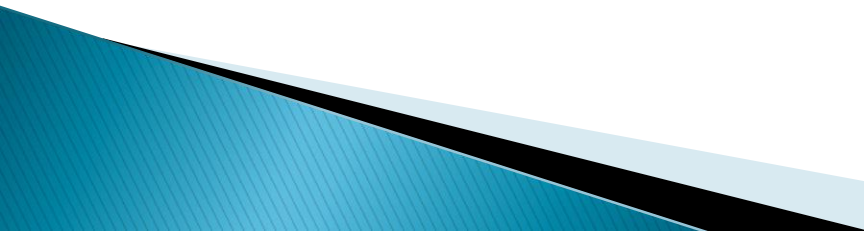
- Amplification – magnify a signal (voltage/current) by transferring energy from an external source
 - Switching – controlling a relative large current between or voltage across two terminals using a small control current or voltage
- 

TRANSISTORS

Two major types of transistors:

Bipolar Junction Transistor (BJT)

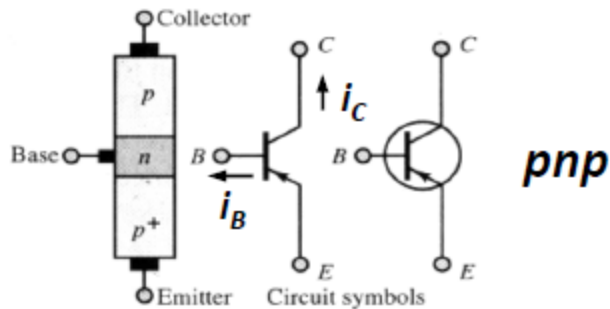
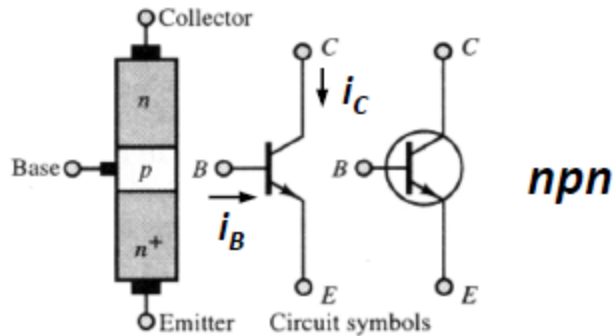

Field Effect Transistor (FET)

MOSFET n-channel

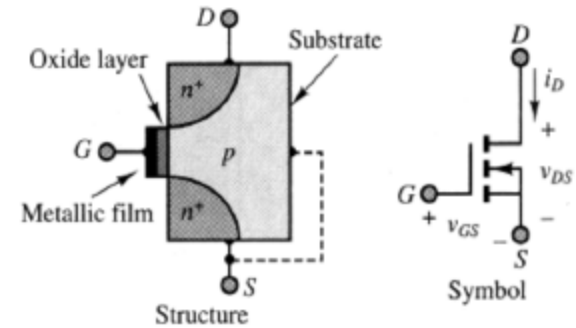

MOSFET p-channel

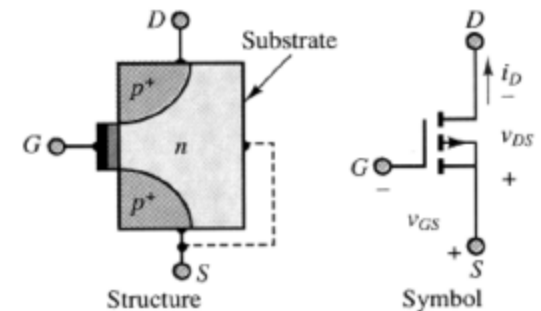

TRANSISTORS

Two major types of transistors:

Bipolar Junction Transistor (BJT)

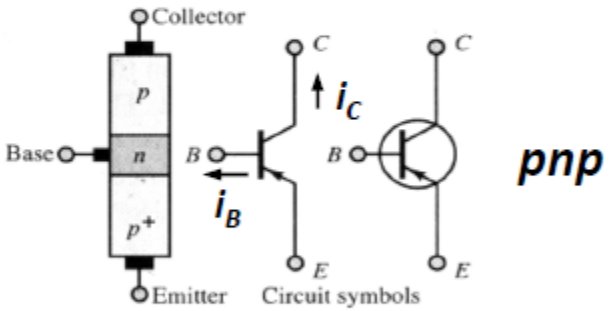
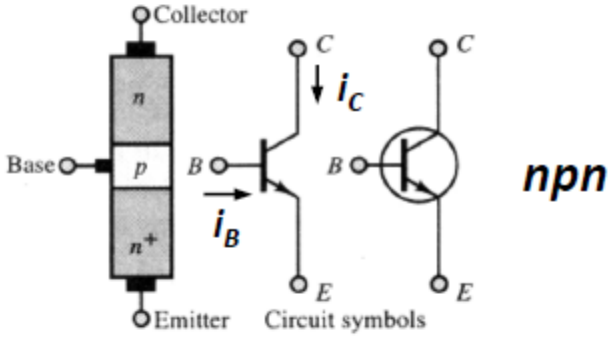

Current controlled

Field Effect Transistor (FET)

MOSFET n-channel

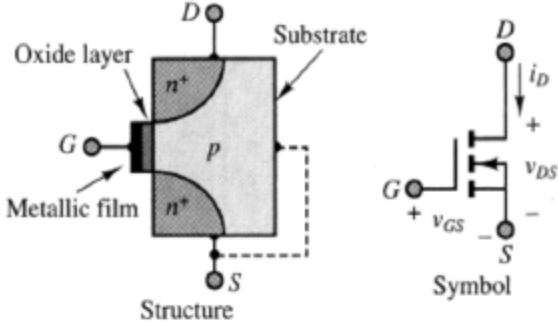

MOSFET p-channel

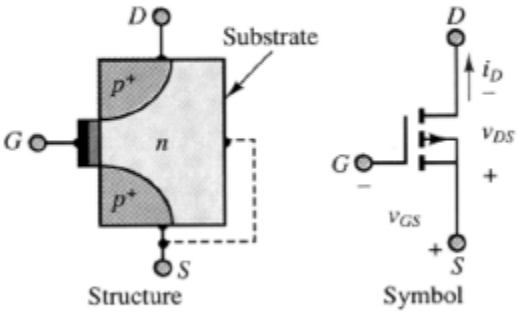

Voltage controlled

BIPOLAR JUNCTION TRANSISTOR (BJT)

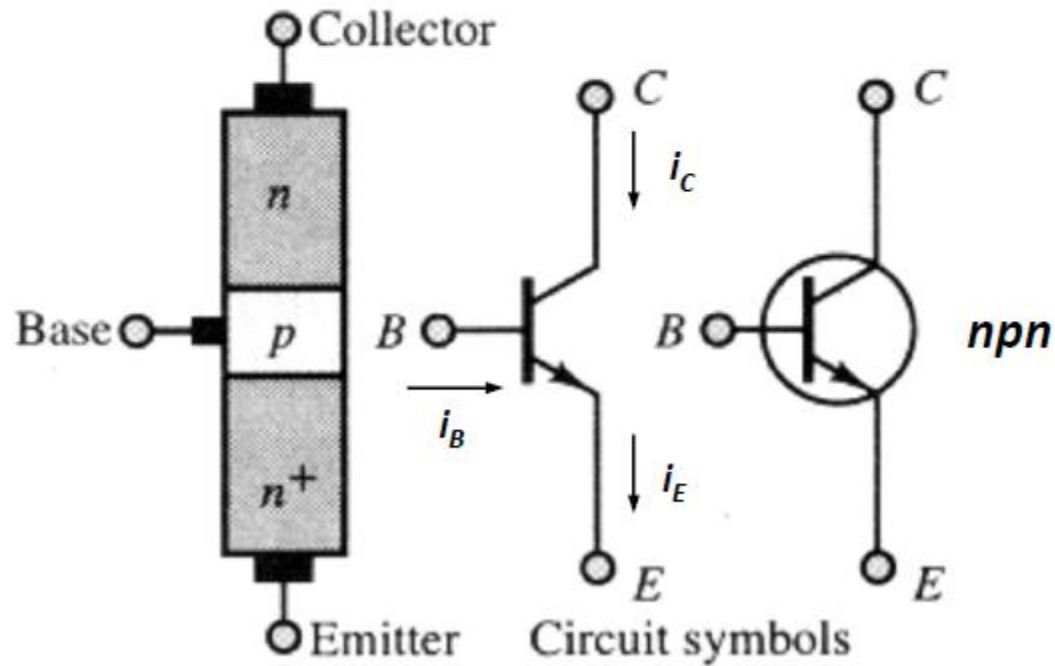

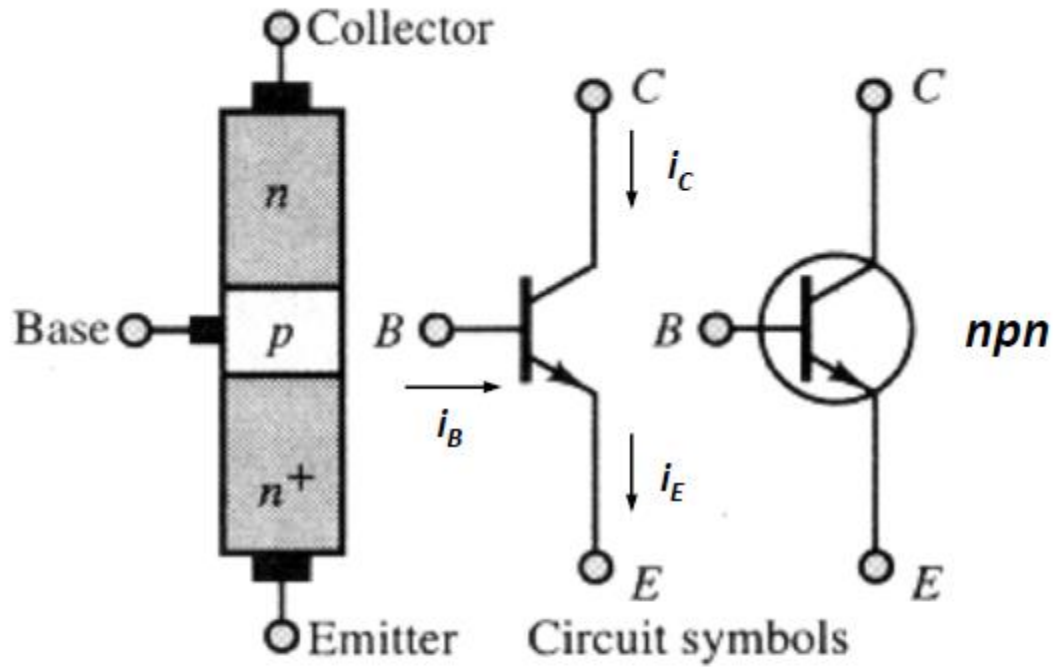

(usually > 0.98) (usually 50 to 300)

BIPOLAR JUNCTION TRANSISTOR (BJT)

$$i_E = i_C + i_B$$

$$\frac{i_E}{i_C} = 1 + \frac{i_B}{i_C}$$

$$\frac{1}{\alpha_{dc}} = 1 + \frac{1}{\beta_{dc}}$$

$$\beta_{dc} = \frac{\alpha_{dc}}{1 - \alpha_{dc}} \quad \leftrightarrow \quad \alpha_{dc} = \frac{\beta_{dc}}{\beta_{dc} + 1}$$

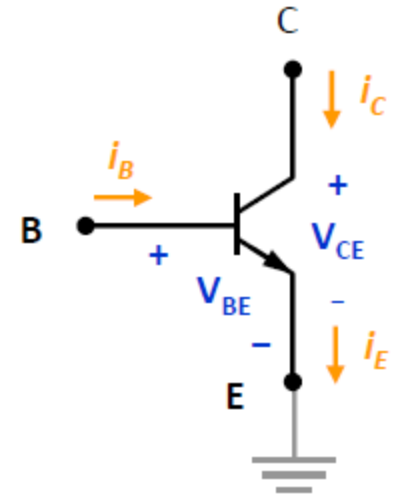

BIPOLAR JUNCTION TRANSISTOR (BJT)

Can be viewed as a current-controlled current source

Three operation modes:

Active Linear – Current Amplification

$$i_C = i_B \beta$$

Cutoff – Open Switch (no collector current)

$$i_C \approx 0, R_{CE} \approx \infty$$

Saturation – Closed Switch ($V_{CE} \rightarrow 0$)

$$i_C \approx i_{C(\text{limit})}, R_{CE} \approx 0$$

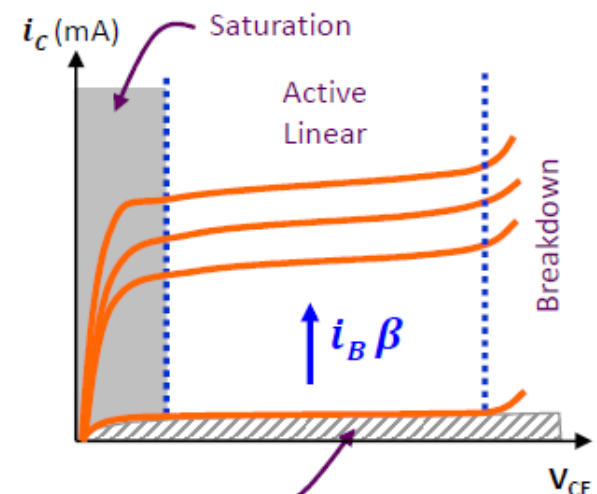
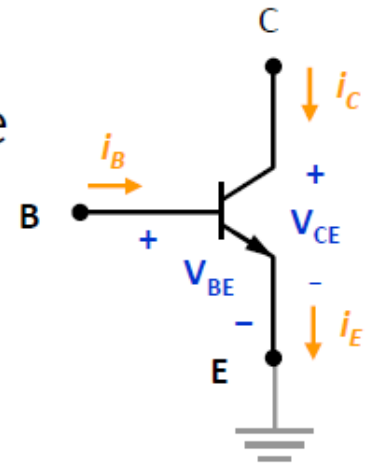

BIPOLAR JUNCTION TRANSISTOR (BJT)

Can be viewed as a current-controlled current source

Active Linear – Current Amplification

$$(V_{BE} = V_Y \text{ \& } V_{CE} > V_Y) \Rightarrow i_C = i_B \beta;$$

- i_C is proportional to i_B
- Current amplification factor β (20 ~ 200) is often denoted as h , hf , or h_{FE} in data sheets.
- Power dissipated: $P = i_C \cdot V_{CE}$

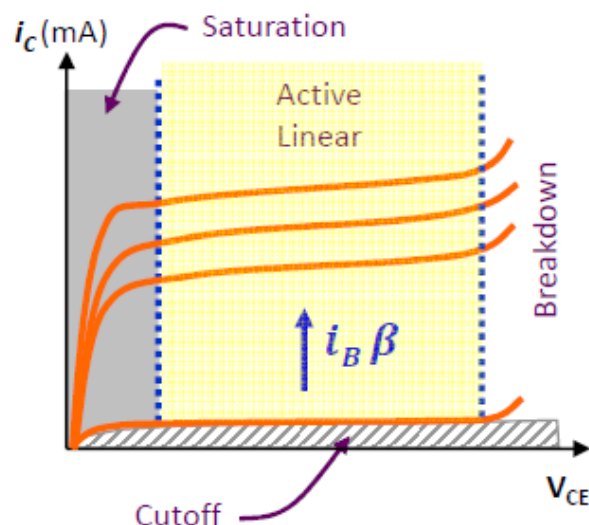
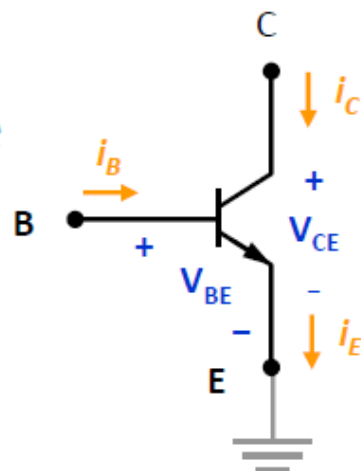

BIPOLAR JUNCTION TRANSISTOR (BJT)

Can be viewed as a current-controlled current source

Cutoff – No collector current flow.

$$V_{BE} < V_Y \Rightarrow i_B = 0 \Rightarrow i_C \approx 0; V_{CE} \geq 0$$

➤ $V_Y = 0.6 \sim 0.7 \text{ V}$

➤ From C to E can be viewed as open switch.

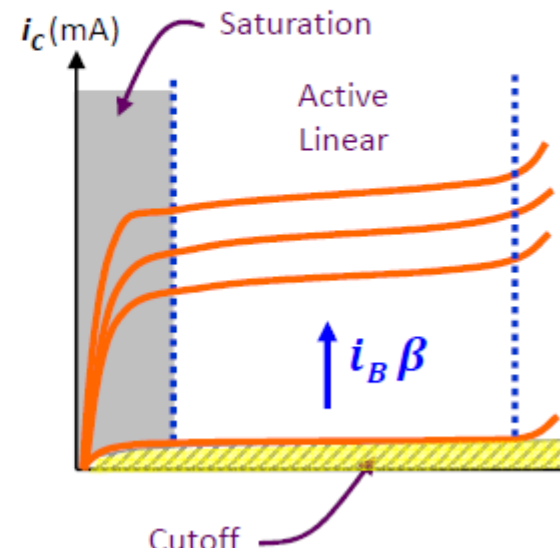
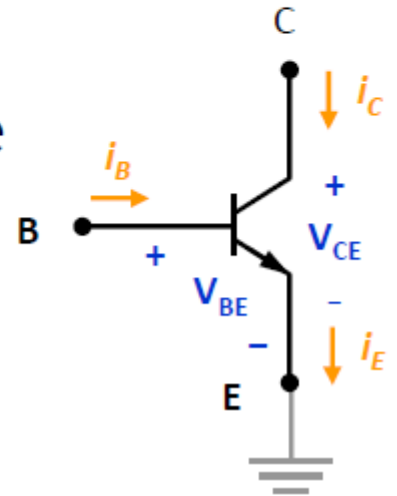

BIPOLAR JUNCTION TRANSISTOR (BJT)

Can be viewed as a current-controlled current source

Saturation – Closed Switch.

$$\left(V_{BE} = V_Y \ \& \ i_B > \frac{i_C(\text{limit})}{\beta} \right) \Rightarrow V_{CE} = V_{SAT} \approx 0.2 \text{ V}$$

- $i_C(\text{limit})$ is controlled by the collector circuit.
- From C to E can be viewed as closed switch.

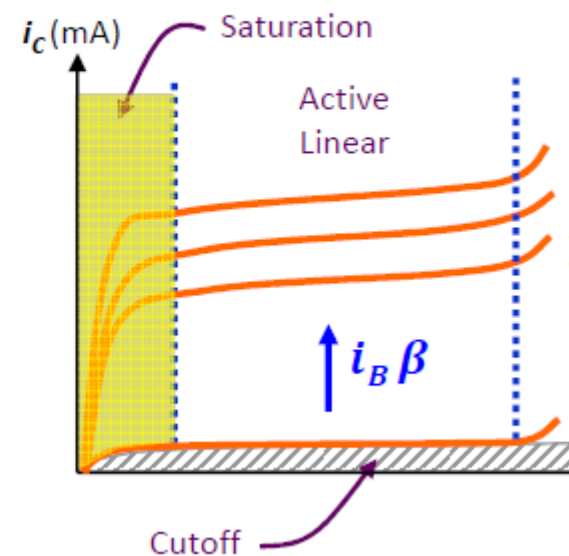
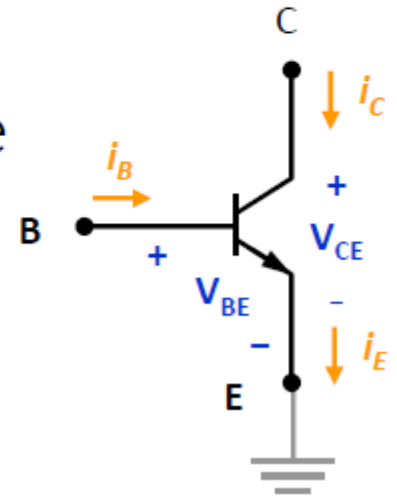

BJT SWITCH CIRCUIT

By carefully controlling the base-emitter voltage and current, the transistor can be made to toggle between the cut-off and the saturation regions, causing it to act as a switch:

- Point A** [$i_B \approx 0$ or *small* $V_{IN} (< 0.6 \text{ V})$]
 - transistor is *cutoff*
 - $i_C \approx i_E \approx 0 \Rightarrow V_{OUT} \approx V_{CC}$
 - Switch is open!
- Point B** [$i_B > i_{B(sat)}$ or *large* $V_{IN} (> 0.7 \text{ V})$]
 - transistor is *saturated*.
 - $V_{OUT} = V_{CE(sat)} \approx 0.2 \text{ V}$ (very small!)
 - Switch is closed!

$$i_B = \frac{V_{IN} - V_{BE(SAT)}}{R_B}; \quad i_C \approx \frac{V_{CC} - V_{CE(SAT)}}{R_L}$$

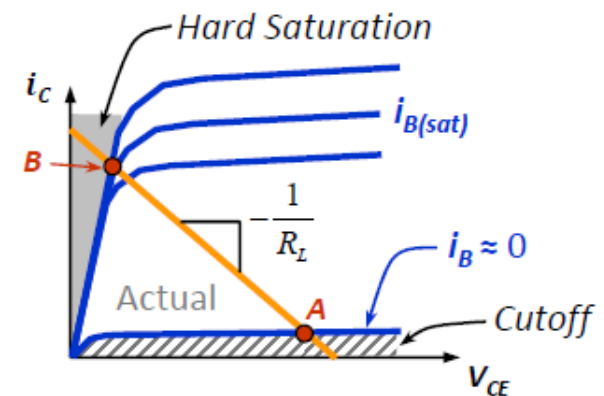
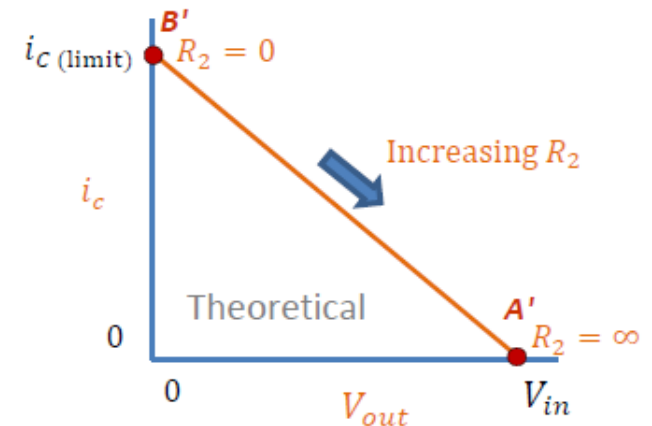
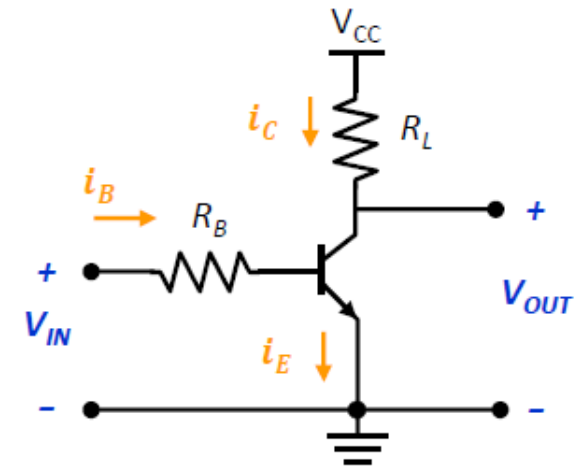

BJT SWITCH CIRCUIT

Suggested design rule:

Choose circuit values such that, when V_{in} goes high,

$$i_B \approx \frac{i_{C(\text{limit})}}{10}$$

Since $\beta_{dc} > 20$ in most cases, this should force the transistor into hard saturation.

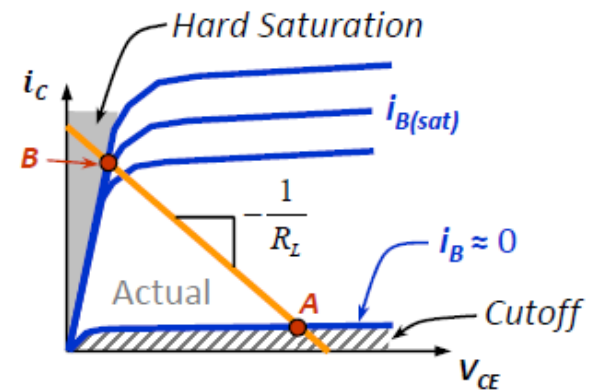
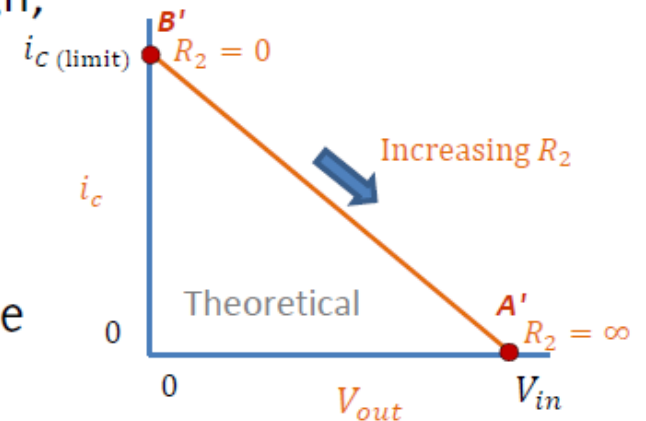
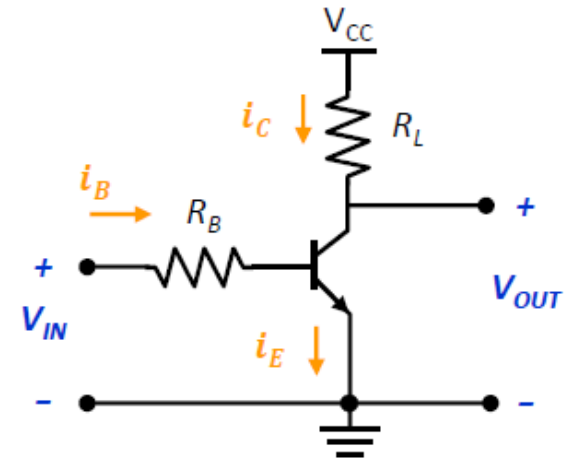

BJT SWITCHING CHARACTERISTICS

Turn-ON and Turn-OFF Time

- turn-ON time $t_{ON} = t_D + t_R$
- turn-OFF time $t_{OFF} = t_S + t_F$

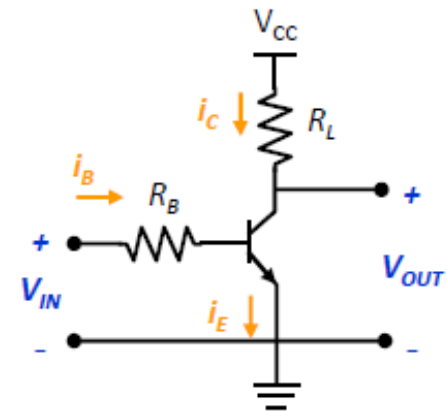

Typical values for 2N3904 transistor:

- $t_d = 35$ nsec
- $t_r = 35$ nsec
- $t_s = 200$ nsec
- $t_f = 50$ nsec

turn-ON time = 70 nsec

turn-OFF time = 250 nsec

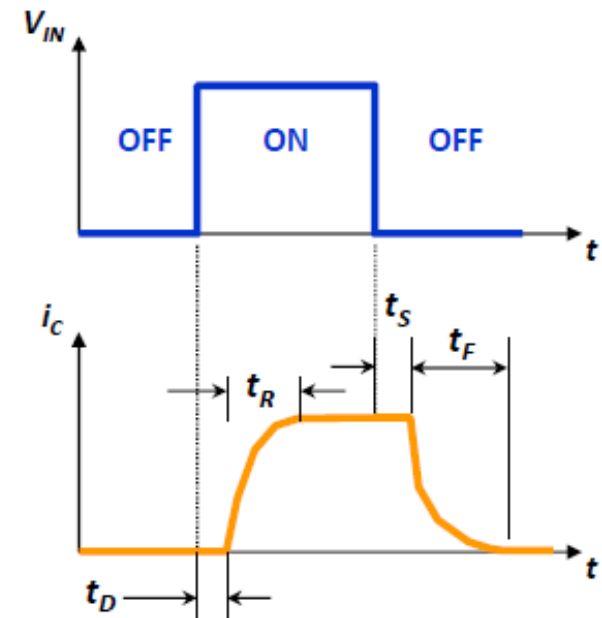

BJT EXAMPLES

LED Driver (BJT as a switch to turn on/off an LED)

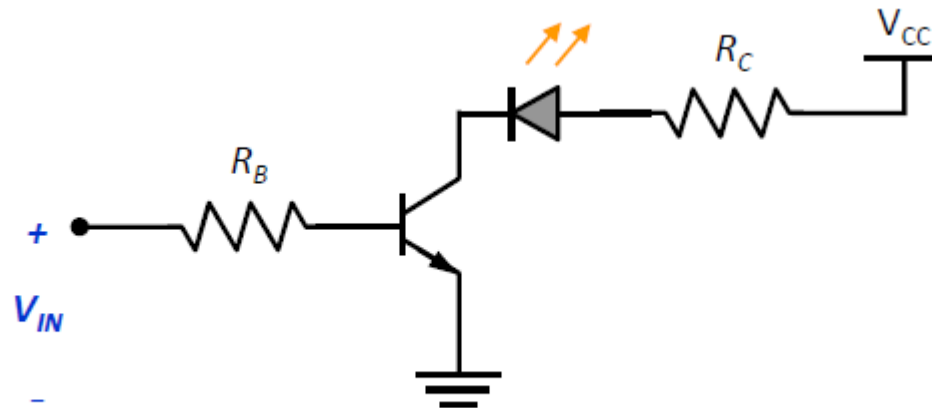

LED Driver (BJT as a switch to turn on/off an LED)

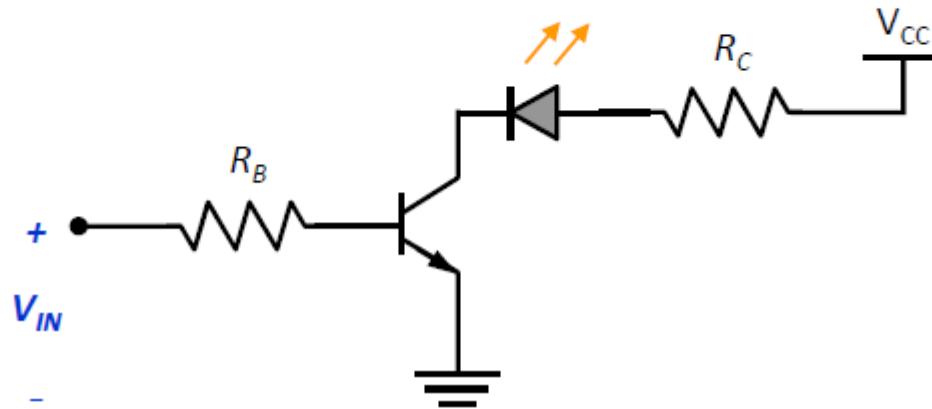

Quick Review:

If $V_{in} = 5V$, and $V_{cc} = 15V$, choose appropriate values for R_B and R_C , so that the LED current is 15 mA. Assume the LED drops 1.8V when lit.

BJT EXAMPLES

LED Driver (BJT as a switch to turn on/off an LED)

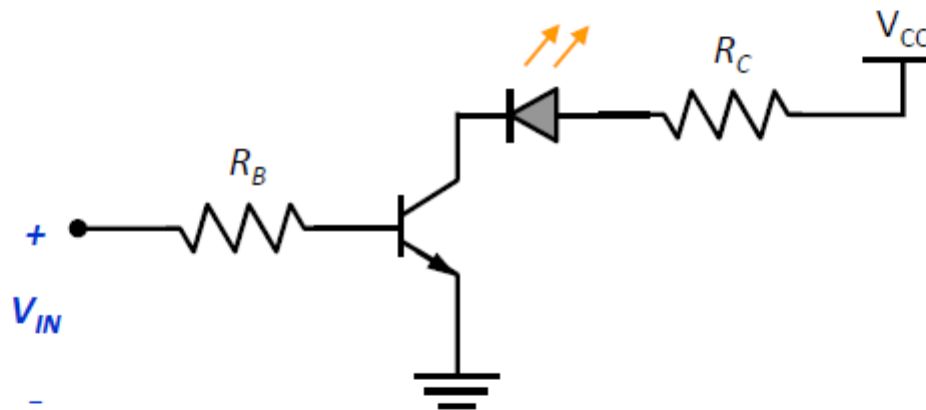

$$R_C = (V_{CC} - V_{LED}) / I_{LED} = (15 - 2V) / 13 \text{ mA} = 1 \text{ k}\Omega$$

$$R_B = (V_{in} - 0.7) / (I_{LED} / 10) = 4.3 \text{ V} / 1.3 \text{ mA} = 3307 \Omega \approx 3.3 \text{ k}\Omega$$

BJT EXAMPLES

Darlington Transistor (or Darlington Pair)

- Composite current gain is the product of the two stages
- β can sometime exceeds 10,000
- Most often found in power electronics that is designed to drive large current load
- Smaller than two individual transistors because the collector is shared

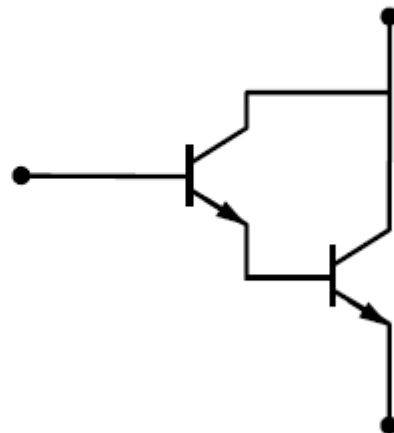

npn Darlington

BJT EXAMPLES

Phototransistor

- Special class of transistors whose junction between the base and emitter allows it to act as a photodiode.
- Slower than a photodiode, but with the gain of a transistor.

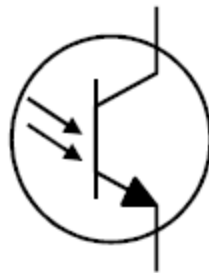

BJT EXAMPLES

Photo-interrupter (Optical Switch)

- LED + phototransistor pair that can be used to detect the presence of an object that may partially or completely interrupt the light between the LED and the phototransistor

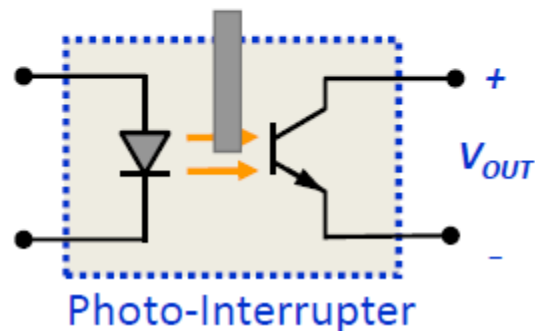

BJT EXAMPLES

Opto-Isolator

- LED + Phototransistor pair.

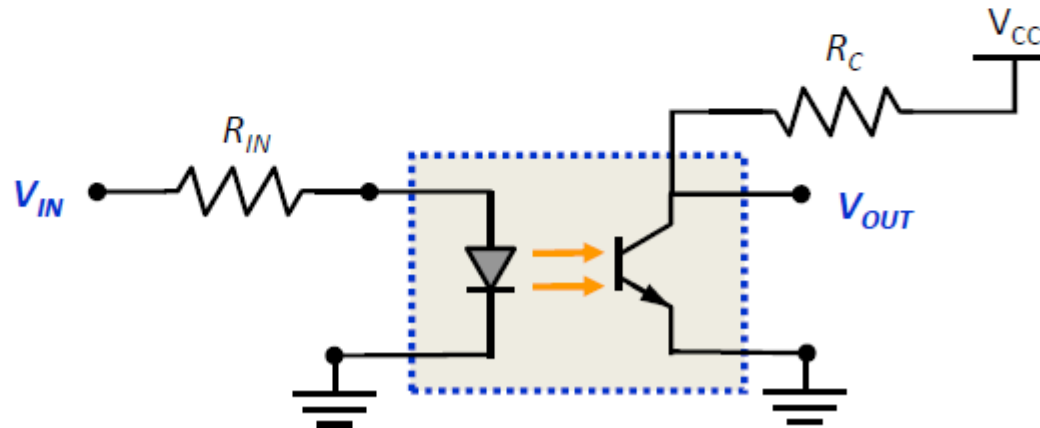

FIELD-EFFECT TRANSISTOR (FET)

Metal-Oxide-Semiconductor (MOS) FET

Uses a metal gate insulated from the silicon substrate by a thin layer of silicon oxide

- Operates in either the enhancement mode or the depletion mode.
- Has little (almost none) gate current – very high input impedance at the gate – good for digital applications

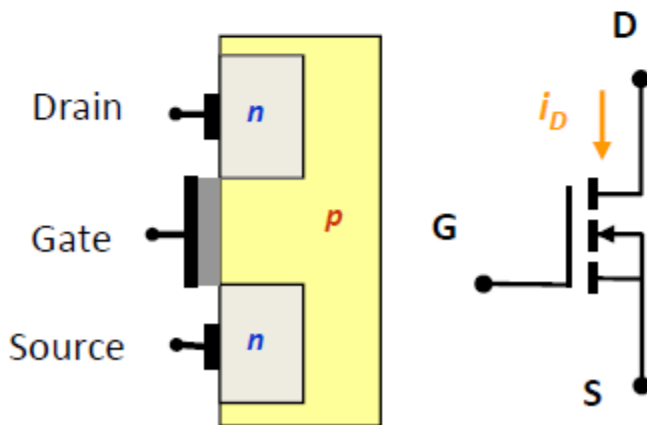

n-channel MOSFET

MOSFET OPERATION (ENHANCEMENT-MODE)

V_T is the *threshold voltage*, or voltage across the gate and the substrate where an n-channel begins to form, allowing the drain-to-source junction to start conducting.

Four operation region:

- Cutoff state – Transistor is turned OFF
 $V_{GS} < V_T \Rightarrow i_D \approx 0; V_{DS} \approx V_{DD}$
- Ohmic state – Linear (or triode) region
 $(V_{GS} > V_T \ \& \ V_{DS} < V_{GS} - V_T \ll V_{DD}) \Rightarrow i_D \approx V_{DD}/R_D ;$
 - i_D is controlled by the drain circuit
 - From D to S can be viewed as closed with a voltage-controlled (small) resistor
- Constant current – Saturation (or active) region
 $(V_{GS} > V_T \ \& \ V_{DS} > V_{GS} - V_T) \Rightarrow i_D \propto (V_{GS} - V_T)^2$
 - i_D is controlled by the gate-source voltage
 - Power dissipated: $P = i_D \cdot V_{DS}$
- Breakdown – Transistor will get VERY HOT!

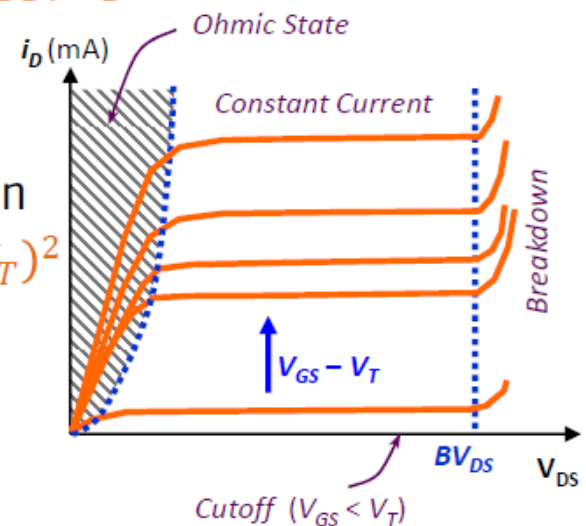
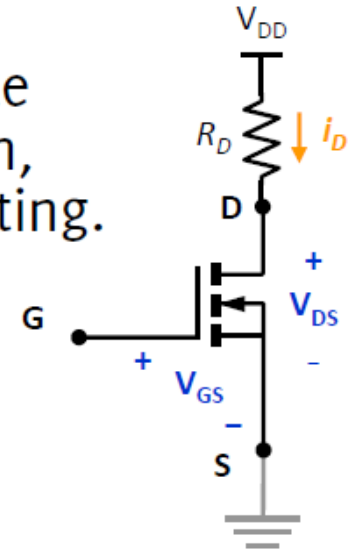

MOSFET SWITCH CIRCUIT

By carefully controlling the gate voltage, a MOSFET transistor can be made to toggle between the cut-off and Ohmic regions, causing it to act as a switch:

- **Point A** ($V_{IN} < V_T$)
 - transistor is cutoff
 - $i_D \approx i_S \approx 0 \Rightarrow V_{OUT} \approx V_{DD}$
 - Switch open!
- **Point B** ($V_{IN} > V_T$)
 - transistor is in Ohmic region
 - $V_{OUT} = V_{DD} - V_{DS} = V_{DD} - i_D(V_{G1}) \cdot R_D$
 - Switch closed!

The MOSFET transistor can be viewed as a gate voltage controlled switch or it can also be viewed as an inverter!

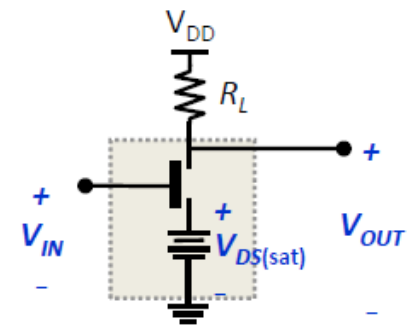
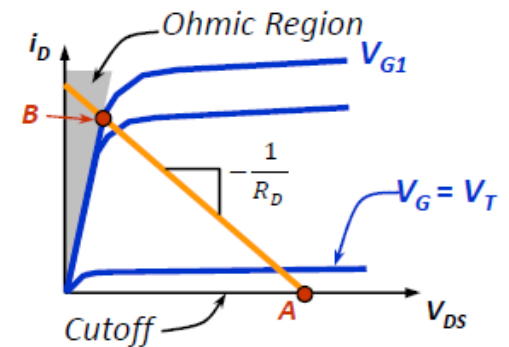
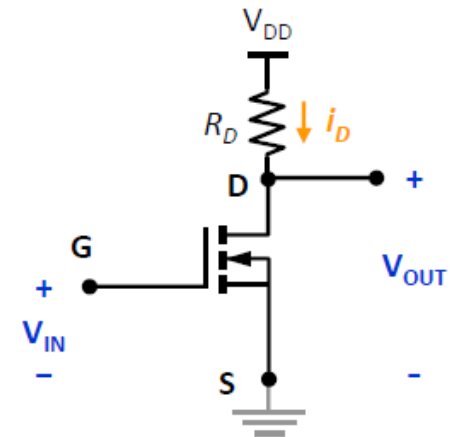

BJT VS. MOSFET (SWITCHING)

Both can be used as current amplifiers:

- BJT: collector current (i_C) proportional (linear) to base current (i_B).
- MOSFET: drain current (i_D) proportional to square of gate voltage (V_G).

Both can be used as three terminal switches or voltage inverters.

- BJT: switching circuit give rise to TTL logics.
- MOSFET: switching circuit give rise to CMOS logics.

BJT usually has larger current capacity than similar sized MOSFET.

MOSFET has much higher input impedance than BJT and is normally off, which translates to less operating power.

MOSFETs are more easily fabricated into integrated circuit form.

MOSFETs less prone to go into thermal runaway.

MOSFETs are susceptible to static voltage (exceed gate breakdown voltage ~ 50 V).

SOME MOSFET EXAMPLES

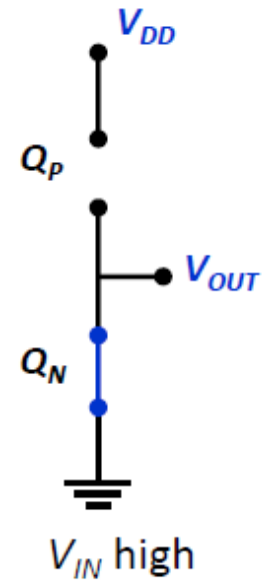
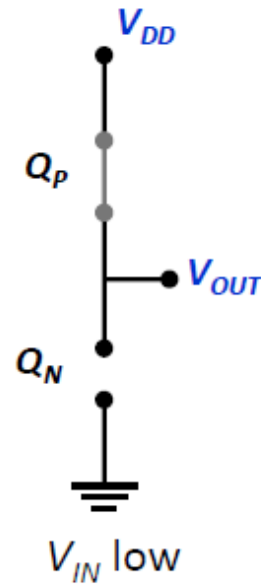
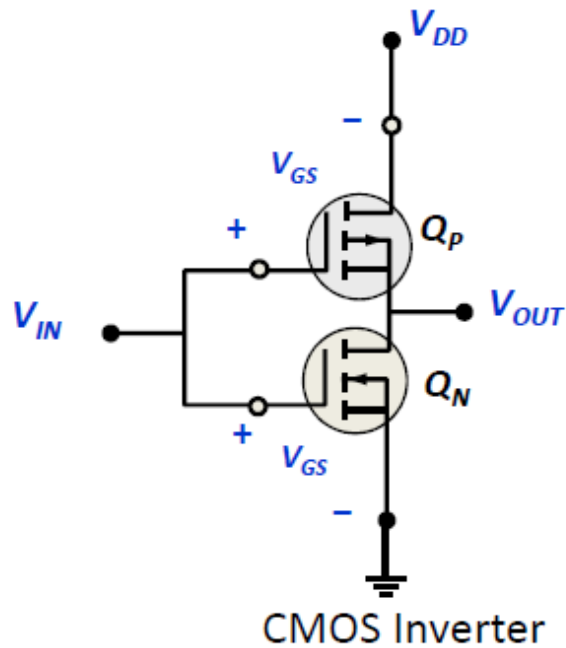

Complementary Metal-Oxide Semiconductor (CMOS) Inverter

POWER AMPLIFICATION

Provide sufficient power to the electro-mechanical or electro-optical devices.

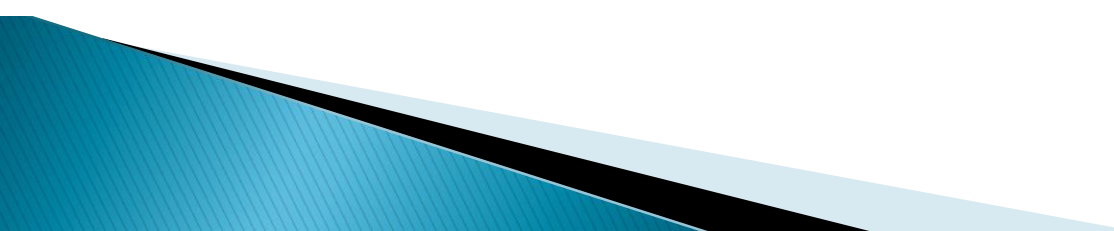
- Many electro-mechanical loads have a low resistance, requiring an emphasis on current gain
 - Unlike power amps for communication and audio systems, DC response is often necessary.
 - For most mechanical systems, power stage bandwidth (-3 dB) is rarely above 10 kHz.
- 

POWER AMPLIFICATION

“High Power”

- >100 mA, >5V
- Actuators
 - DC motors
 - Stepper motors
 - Solenoids
- Some sensors
 - IR sensors
- Big LEDs

“Low Power”

- ~ 10 mA, 3.3 or 5 V
- Microcontrollers
 - Controlling motors
 - Reading sensors
 - Processing controllers
- Some sensors
- Small LEDs

Transistors use
“low power”
to control
“high power”

POWER AMPLIFICATION

Low Power NPN (2N3904)

i_c (max): 200 mA

P_D : 625 mW

β : 100-300

High-Power NPN (2N3055)

i_c (max): 15 A

P_D : 115 W

β : 20-70

POWER AMPLIFICATION

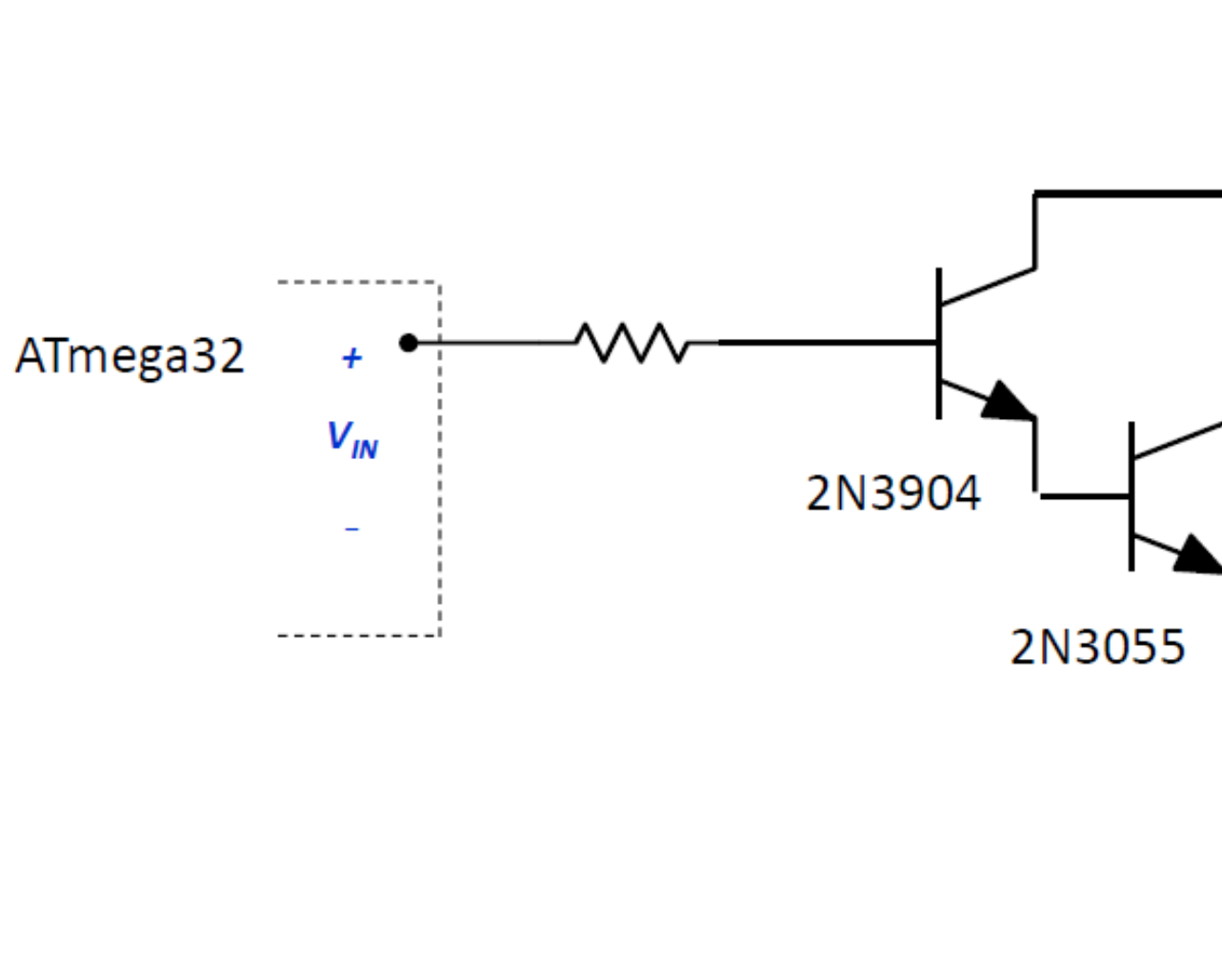

POWER AMPLIFICATION

Medium Power Darlington Pair (TIP120)

i_c (max): 4 A

P_D : 65 W

β : 2500

POWER AMPLIFICATION

Forward/Reverse Control

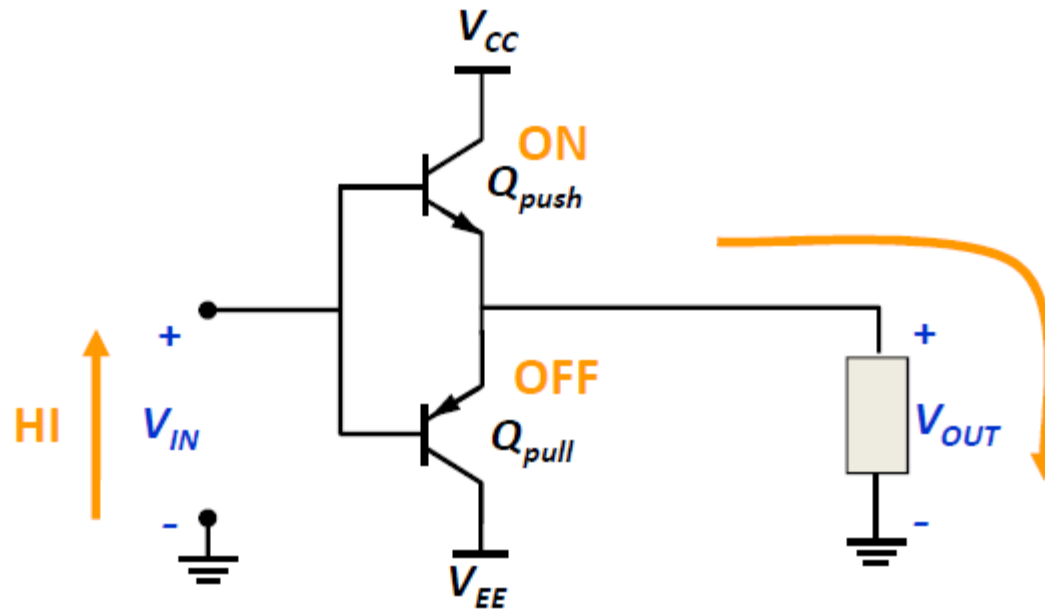

POWER AMPLIFICATION

Forward/Reverse Control

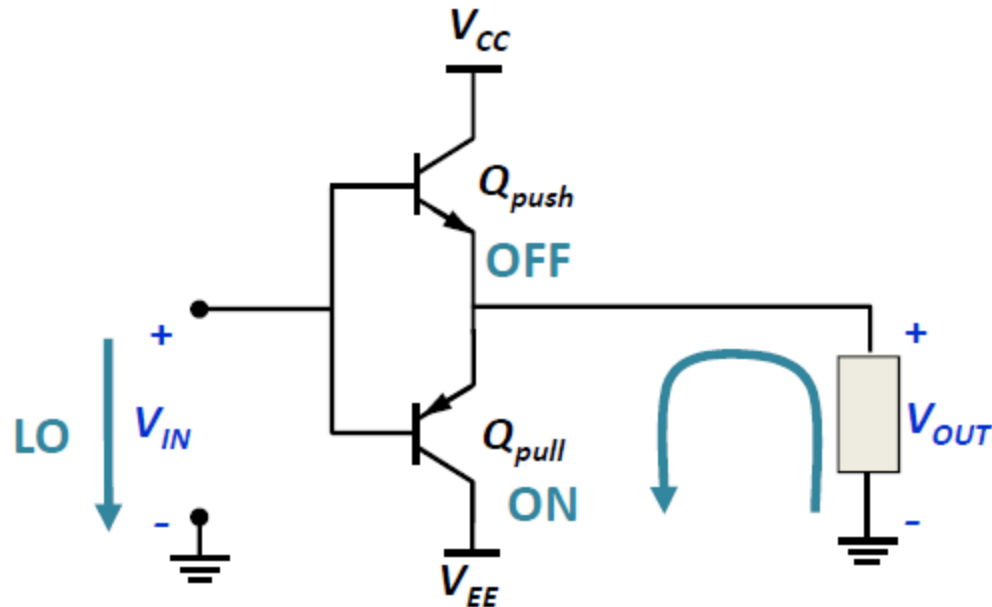

TRANSISTOR SWITCHES

Controlling current to actuators and sensors -- where to place the load?

- Can be connected directly to a digital output (if the digital output stage can supply the required base current)

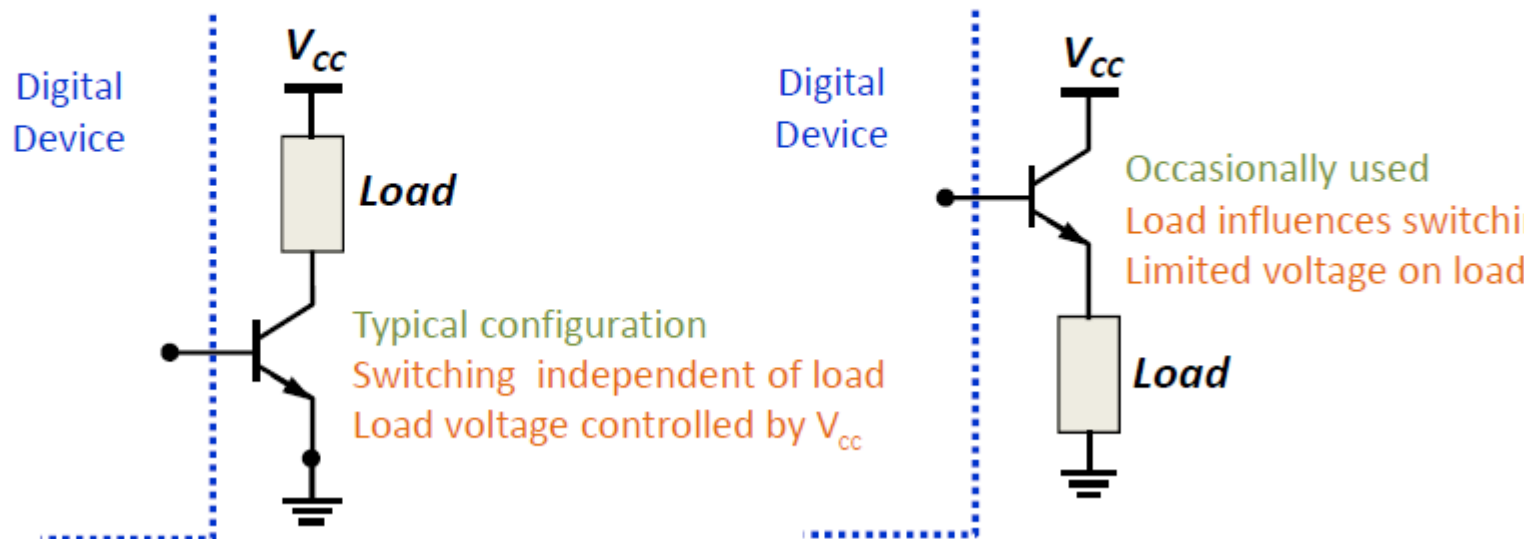

OPEN-COLLECTOR OUTPUT

- Digital device output is the open-collector of a BJT transistor.
- Base-emitter junction of BJT transistor turned on/off with digital output
- Need to connect the output (collector) to a voltage source through pull-up resistor R_P to obtain anticipated output
- Can drive an analog device if capable of sinking adequate current. If not, need to use another more “powerful” transistor

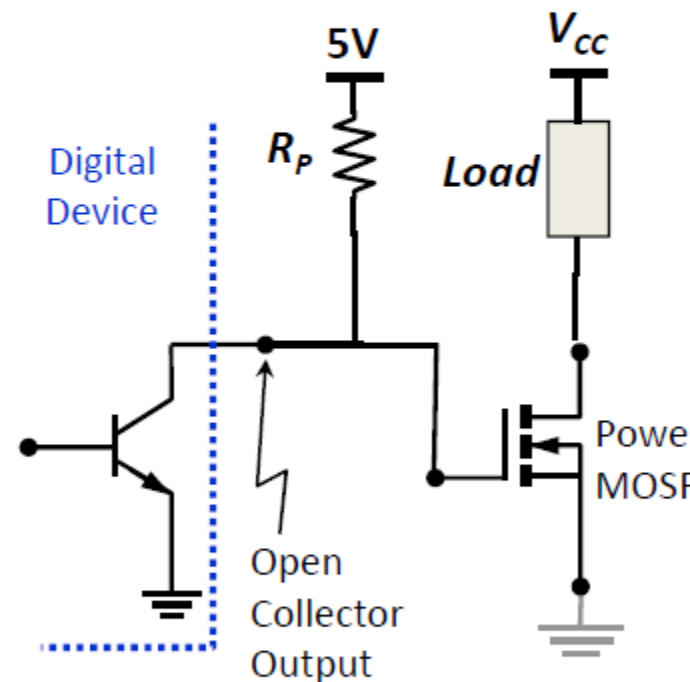

DRIVING INDUCTIVE LOADS

- Inductive loads are very common in electro-mechanical devices, e.g. motors, solenoids, and voice-coil motor etc.
- Voltage across an inductor is —
- A large voltage will build-up across the inductor to switch-off the inductor current. This voltage can be large enough to damage the transistor (inductor kickback).

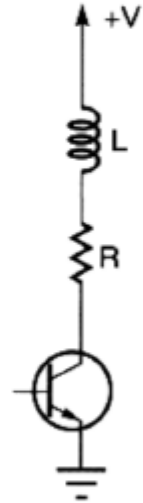

DRIVING INDUCTIVE LOADS

- To avoid this, a freewheeling (kickback) diode can be added in parallel with the inductive load:

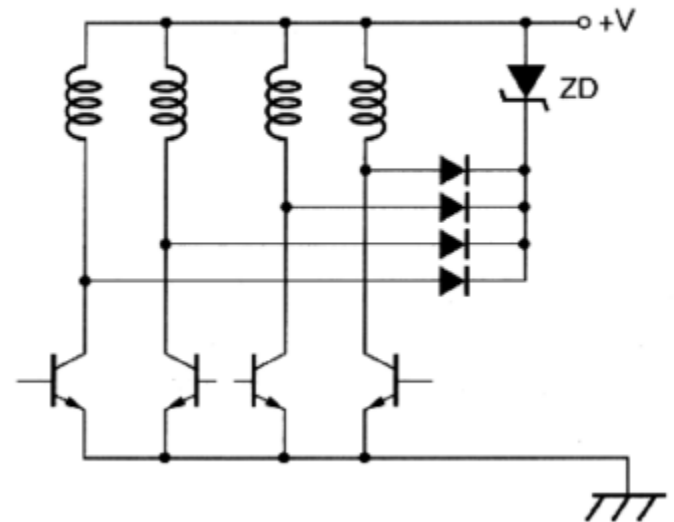
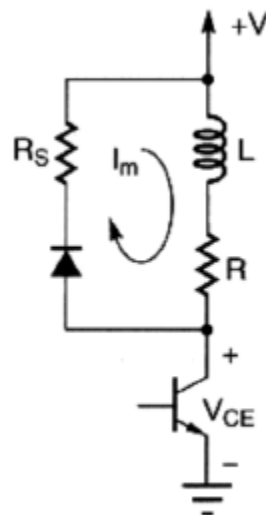
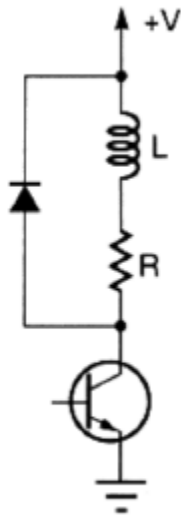

AMPLIFIERS

“Class A”

- Transistor in linear amplification region at all times
- Requires only a single transistor; simple to build
- *Maximum* efficiency of 25% with capacitive coupling

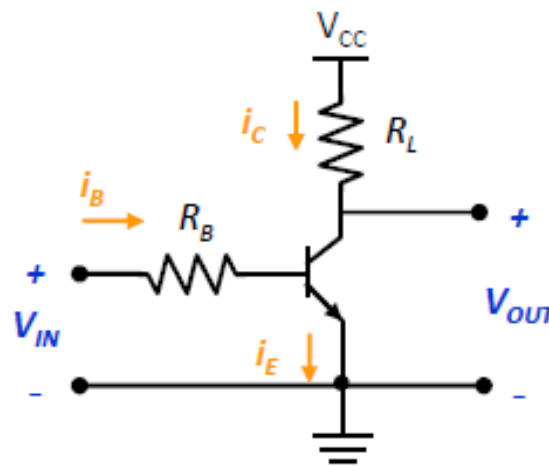

AMPLIFIERS

“Class B”

- Push-pull amplifier
- Maximum efficiency of 78%
- Typical efficiency of 70%

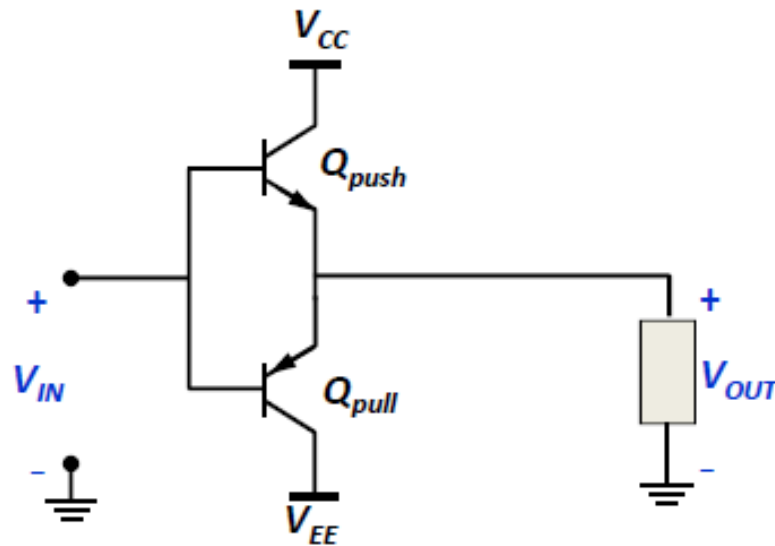

AMPLIFIERS

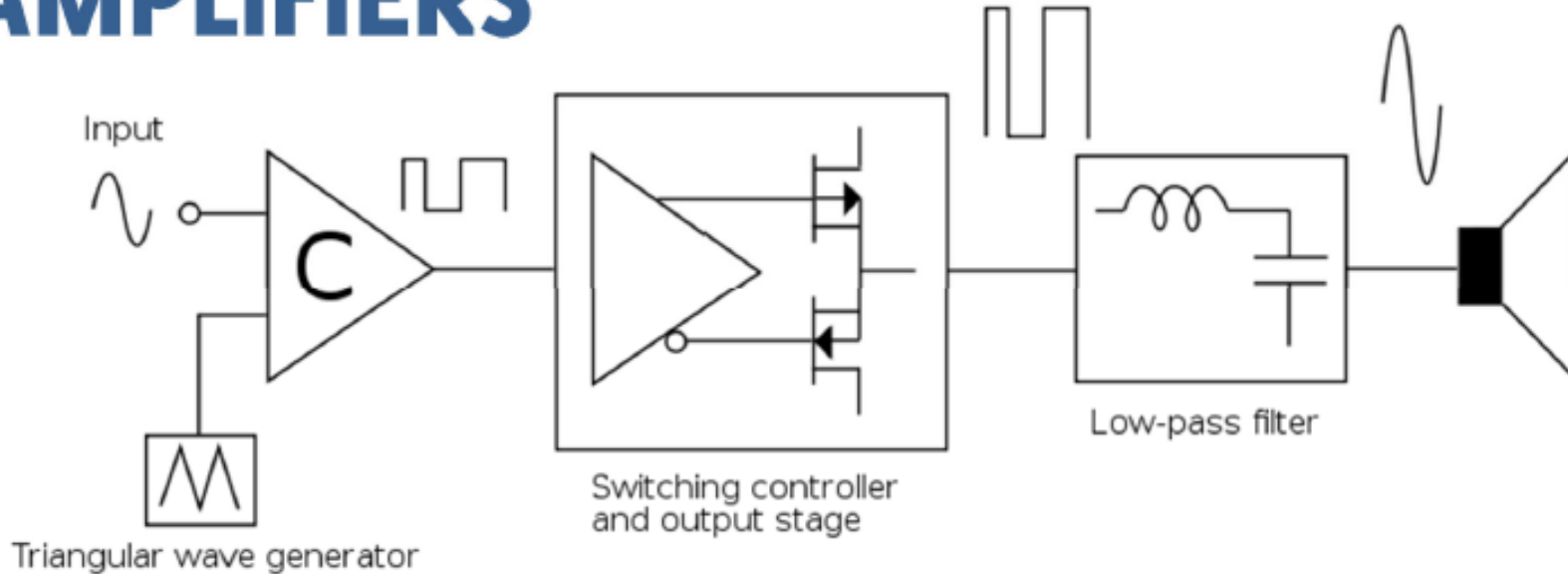

“Class D” amplifier

- Transistors act in saturation mode (switching on and off)
- Motor acts as low-pass filter
- Maximum efficiency of 100%
- Typical efficiency of 80% to 95%

OPERATIONAL AMPLIFIERS (OP-AMPS)

5 terminal device capable of performing many useful operations:

- Addition
 - Subtraction
 - Amplification
 - Integration
 - Filtering
- 

OPERATIONAL AMPLIFIERS (OP-AMPS)

Op Amp Operation (Difference Amplifier)

- $E^+ > E^-$ then the output is driven in the Positive direction
- $E^- > E^+$ then the output is driven in the Negative direction

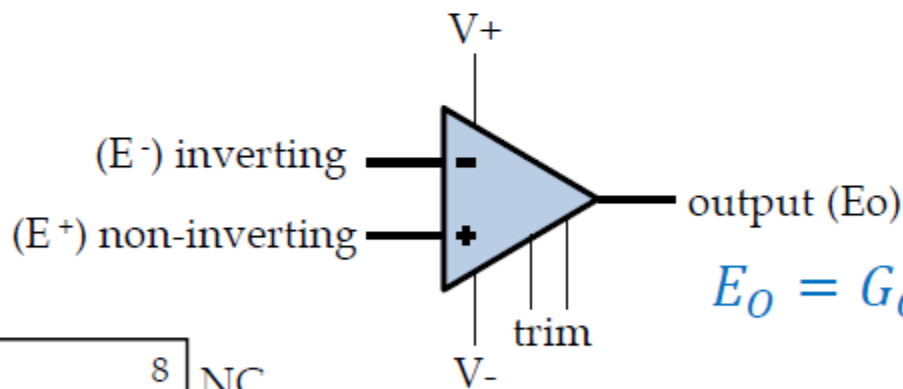

$$E_o = G_o(E^+ - E^-)$$

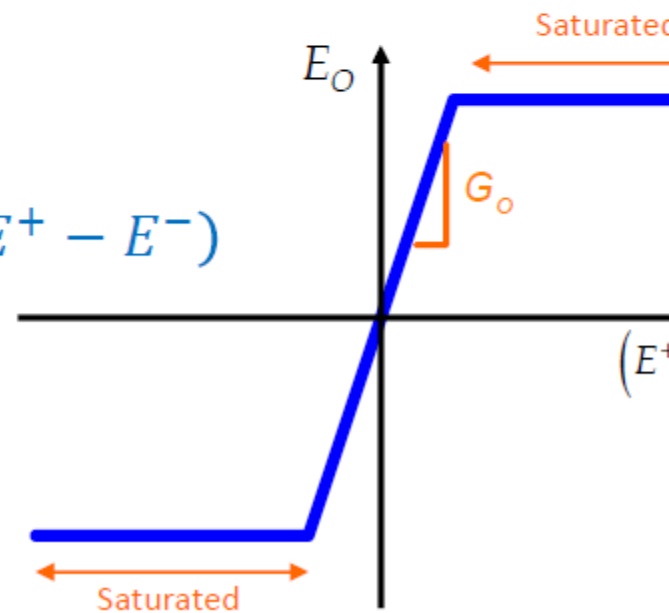
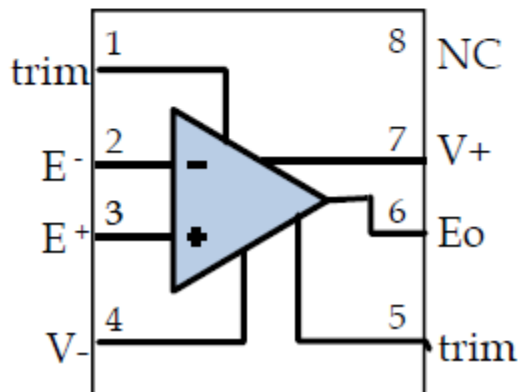

OP-AMP MODEL

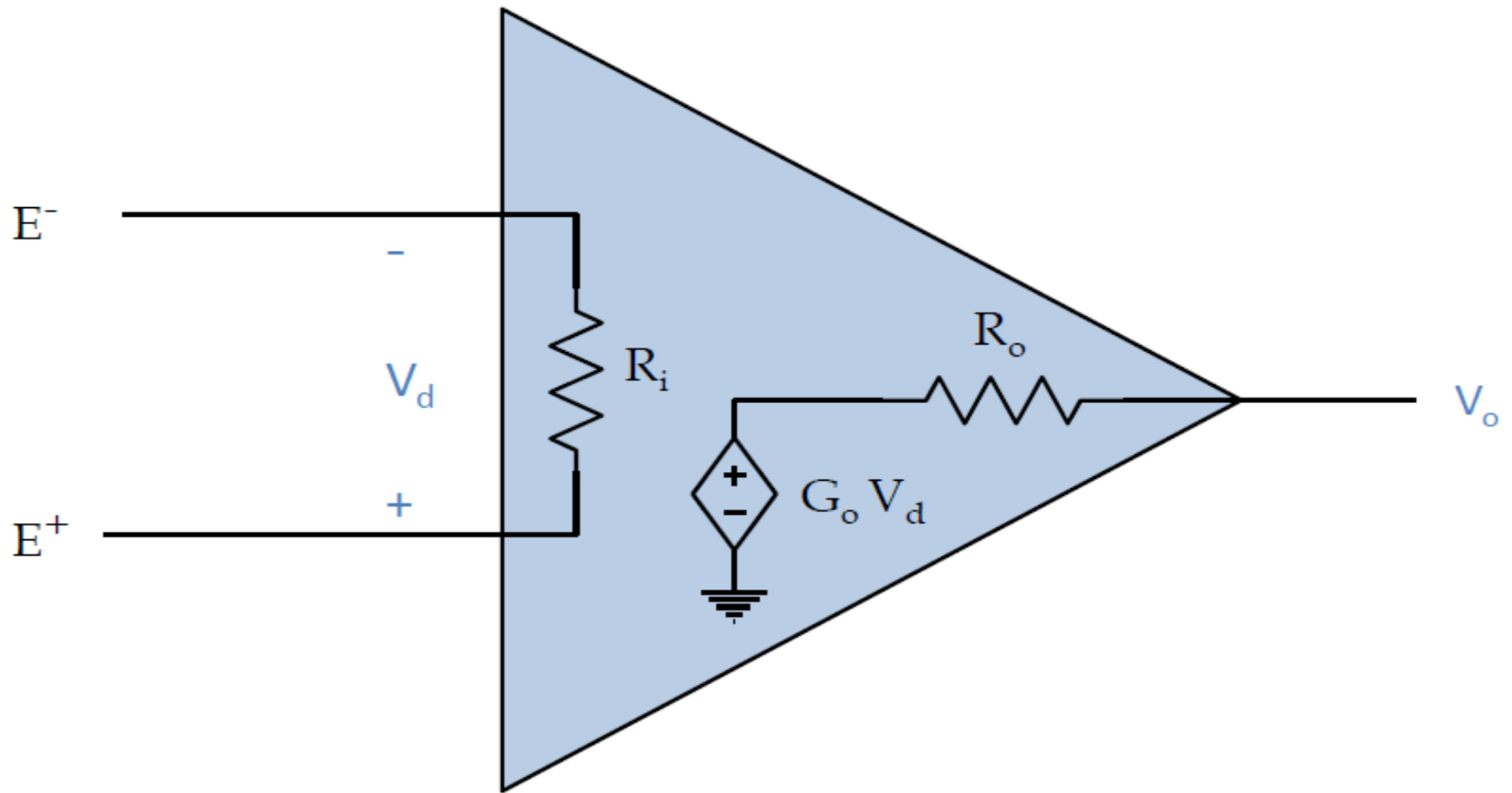

OP-AMP CHARACTERISTICS

<u>Ideal</u>		<u>Reality</u>
Infinite	High Open Loop Gain	10^4 to 10^6
Infinite	High Input Impedance	300 K Ω to 1000 G Ω
0	Low Output Impedance	10 Ω to 5 K Ω (150 - 200 typical)
Infinite	High Bandwidth	
0	Zero Offset	

Implications:

- Seldom used in open-loop mode
- Almost exclusively used in feedback mode

OP-AMP MODEL

If $R_i = \infty$, input currents are zero

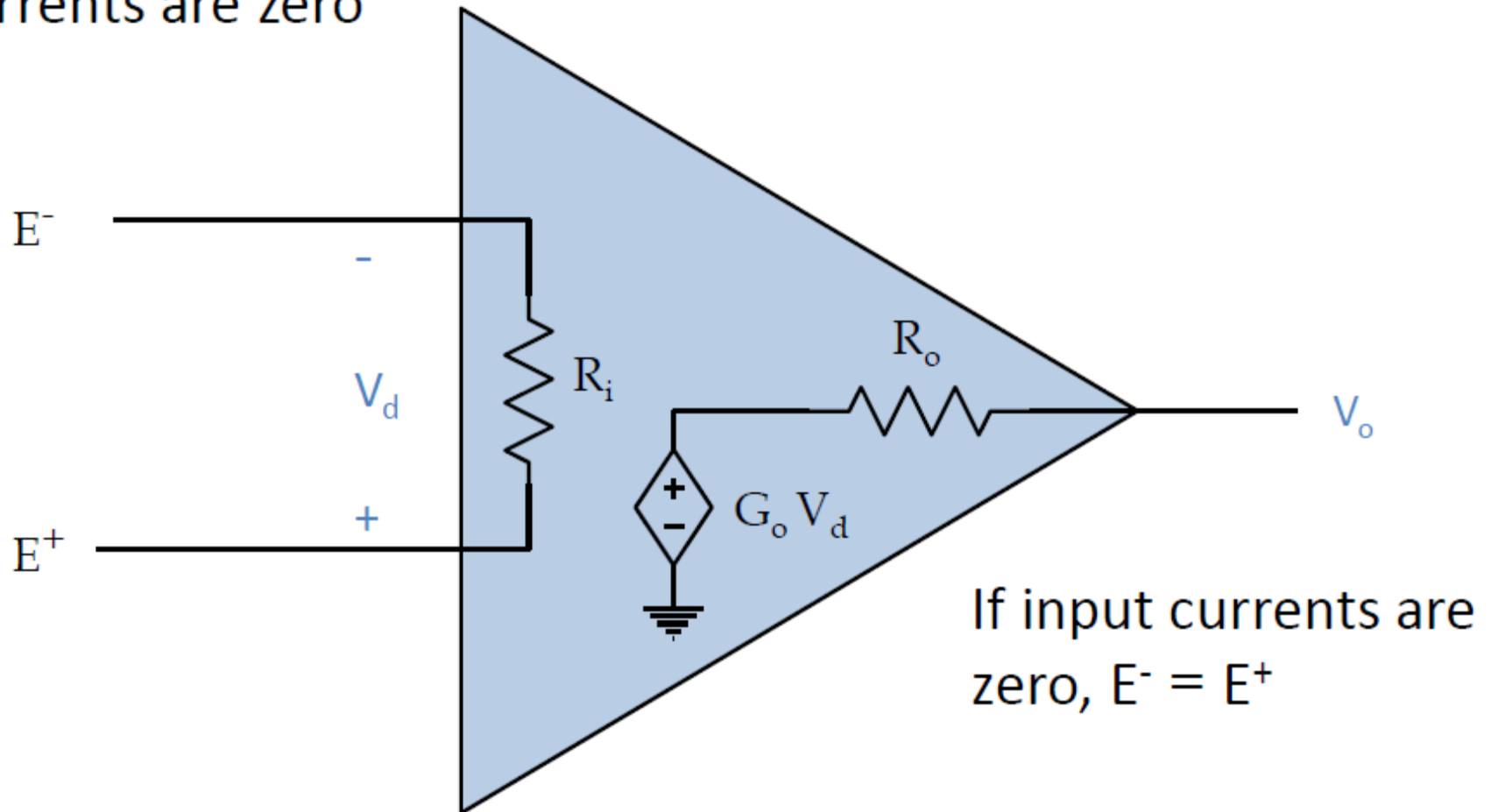

If input currents are zero, $E^- = E^+$

THE GOLDEN RULES:

1. The inputs draw no current

- Op-amp draws very little input current (0.5 mA for a 741C) (due to high input impedance); we round it to zero for practical calculation.

2. The op-amp will do whatever is necessary to bring the voltage difference between the inputs to zero

- It “looks” at the input terminals and changes its output voltage such that the external feedback network will bring the input difference to zero.

These rules only apply when the op-amp is operated:

- Within its listed specifications
- In negative feedback mode

OP-AMP EXAMPLES

- Inverting Amplifier

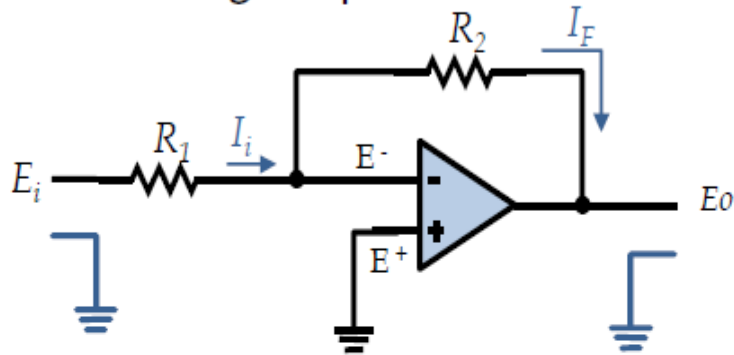

$$\frac{E_i - E^-}{R_1} = I_i = I_F = \frac{E^- - E_O}{R_2}$$

$$E^- = E^+ = 0$$

$$\frac{E_O}{E_i} = -\frac{R_2}{R_1} \Rightarrow E_O = -\frac{R_2}{R_1} E_i$$

- Non-inverting Amplifier

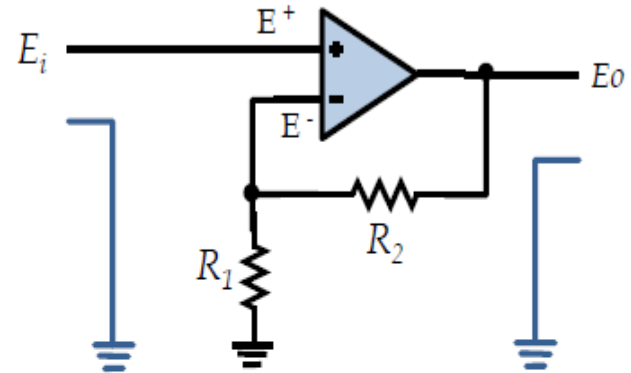

$$E_i = \left(\frac{R_1}{R_1 + R_2} \right) E_O \Rightarrow E_O = \left(\frac{R_1 + R_2}{R_1} \right) E_i$$

$$E_O = \left(1 + \frac{R_2}{R_1} \right) E_i$$

PRACTICAL OP AMPS

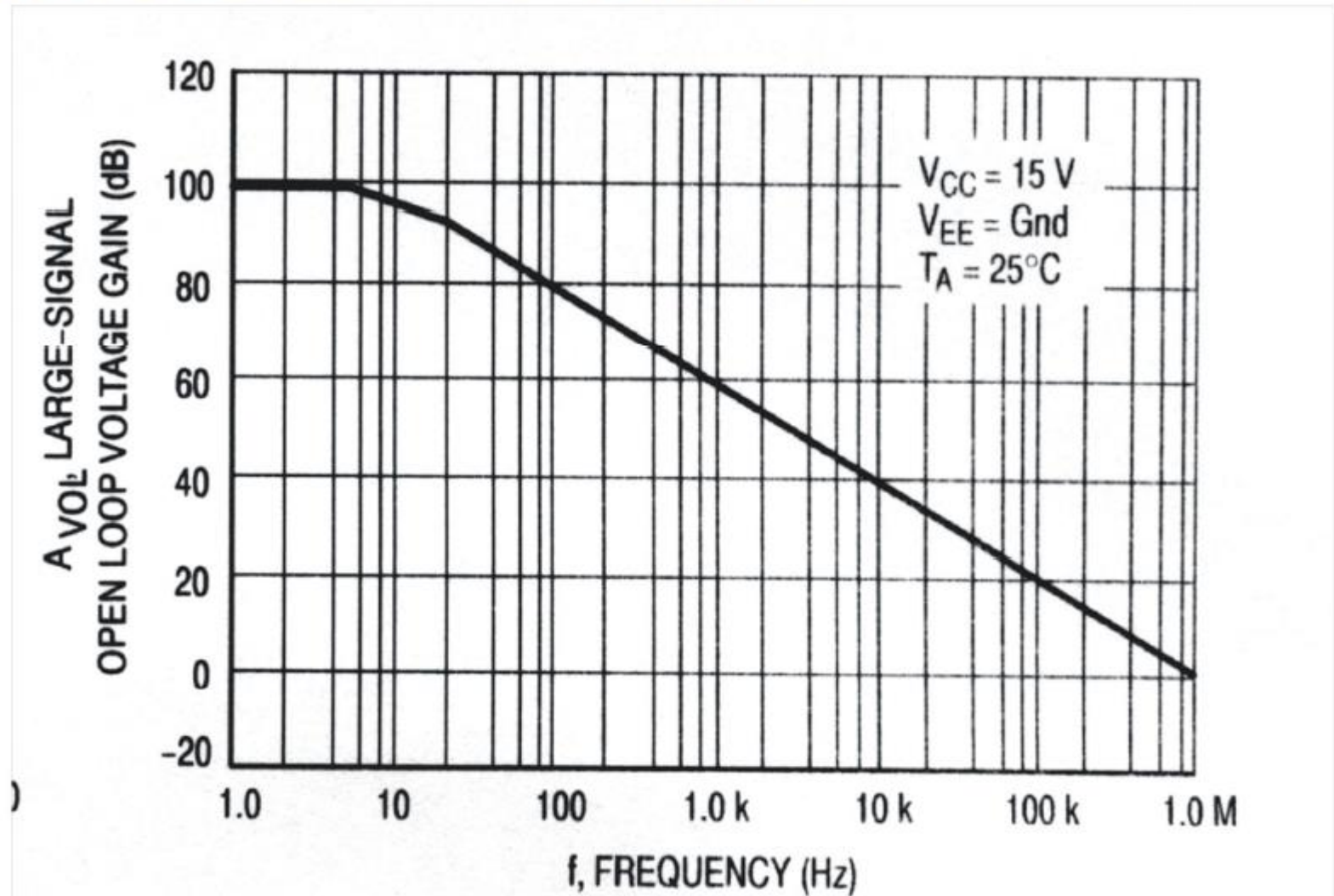

Figure 5. Open Loop Frequency

WHAT'S INSIDE?

741 op-amp schematic

Input Differential Amplifier

Output Amplifier

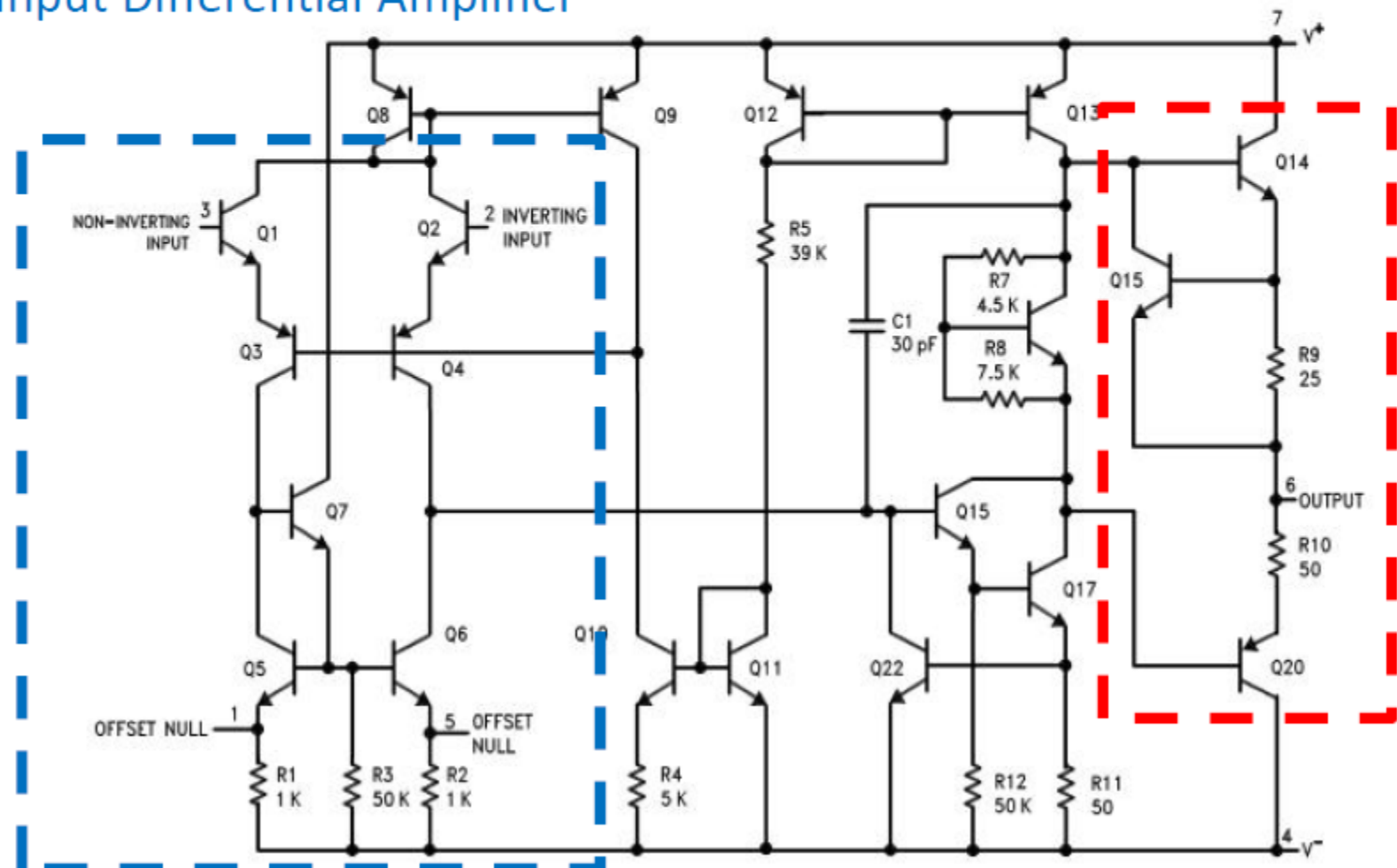

ASIDE: AMPLIFIERS

When driving a motor, should we operate a transistor in linear amplification mode or saturation mode?

- Linear amplification mode controls speed with the base current/voltage
- Saturation mode controls speed with duration of on/off periods
 - Similar to modulation
 - Motor acts as a low-pass filter

Define efficiency in terms of power

$$\eta = \frac{P_{out}}{P_{in}}$$

The ideal operational amplifier

- ▶ The ideal operational amplifier
 - Terminals
 - Basic ideal op-amp properties
- ▶ Op-amp families
- ▶ Operational amplifier circuits
 - Comparator and buffer
 - Inverting and non-inverting amplifier
 - Summing and differential amplifier
 - Integrating and differentiating amplifier
 - Current-voltage conversion

The ideal op-amp

- ▶ Primary op-amp terminals
 - Inverting input
 - Non-inverting input
 - Output
 - Power supply

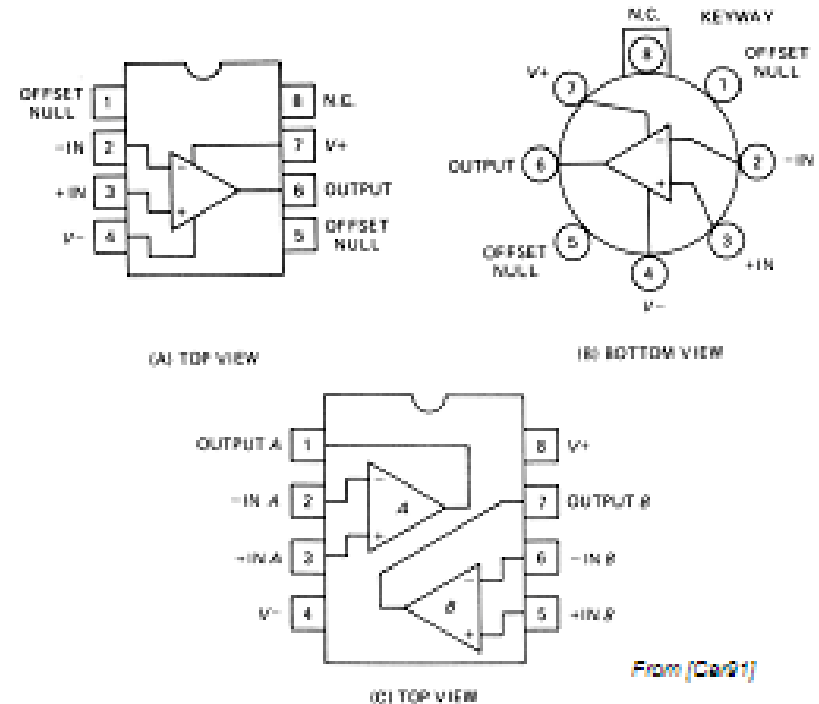

Fig. 12-6 Packaging for industry standard op-amp (741) in (A) DIP and (B) metal can packages, (C) dual op-amp such as 1458 device.

Ideal op-amp characteristics

- ▶ The ideal op-amp is characterized by seven properties
 - Knowledge of these properties is sufficient to design and analyze a large number of useful circuits
- ▶ Basic op-amp properties
 - Infinite open-loop voltage gain
 - Infinite input impedance
 - Zero output impedance
 - Zero noise contribution
 - Zero DC output offset
 - Infinite bandwidth
 - Differential inputs that stick together

Ideal Op-Amp Properties

- ▶ Property No.1: Infinite Open-Loop Gain
 - Open-Loop Gain A_{vol} is the gain of the op-amp without positive or negative feedback
 - In the ideal op-amp A_{vol} is infinite
 - Typical values range from 20,000 to 200,000 in real devices
- ▶ Property No.2: Infinite Input Impedance
 - Input impedance is the ratio of input voltage to input current

$$Z_{in} = \frac{V_{in}}{I_{in}}$$

- When Z_{in} is infinite, the input current $I_{in}=0$
 - High-grade op-amps can have input impedance in the T Ω range
 - Some low-grade op-amps, on the other hand, can have mA input currents

Ideal Op-Amp Properties

▶ Property No. 3: Zero Output Impedance

- The ideal op-amp acts as a perfect internal voltage source with no internal resistance
 - This internal resistance is in series with the load, reducing the output voltage available to the load
 - Real op-amps have output-impedance in the 100–20Ω range
- Example

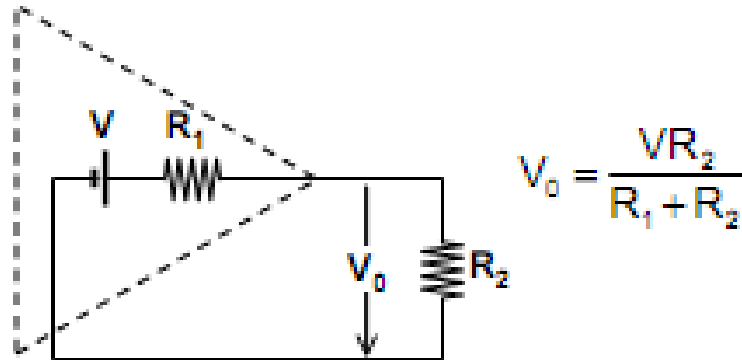

$$V_0 = \frac{VR_2}{R_1 + R_2}$$

Ideal Op-Amp Properties

- ▶ Property No.4: Zero Noise Contribution
 - In the ideal op-amp, zero noise voltage is produced internally
 - This is, any noise at the output must have been at the input as well
 - Practical op-amp are affected by several noise sources, such as resistive and semiconductor noise
 - These effects can have considerable effects in low signal-level applications
- ▶ Property No. 5: Zero output Offset
 - The output offset is the output voltage of an amplifier when both inputs are grounded
 - The ideal op-amp has zero output offset, but real op-amps have some amount of output offset voltage

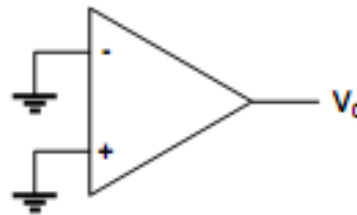

Ideal Op–Amp Properties

- ▶ **Property No. 6: Infinite Bandwidth**
 - The ideal op–amp will amplify all signals from DC to the highest AC frequencies
 - In real opamps, the bandwidth is rather limited
 - This limitation is specified by the Gain–Bandwidth product (GB), which is equal to the frequency where the amplifier gain becomes unity
 - Some op–amps, such as the 741 family, have very limited bandwidth of up to a few KHz
- ▶ **Property No. 7: Differential Inputs Stick Together**
 - In the ideal op–amp, a voltage applied to one input also appears at the other input

Operational amplifier types

▶ General-Purpose Op-Amps

- These devices are designed for a very wide range of applications
 - These op-amps have limited bandwidth but in return have very good stability (they are called frequency compensated)
 - Non-compensated op-amps have wider frequency response but have a tendency to oscillate

▶ Voltage Comparators

- These are devices that have no negative feedback networks and therefore saturate with very low (μV) input signal voltages
 - Used to compare signal levels of the inputs

▶ Low Input Current Op-Amps

- Op-amps with very low (pico-amp) input currents, as opposed to μA or mA input currents found in other devices

▶ Low Noise Op-Amps

- Optimized to reduce internal noise
 - Typically employed in the first stages of amplification circuits

▶ Low Power Op-Amps

- Optimized for low power consumption
 - These devices can operate at low power-supply voltages (i.e., $\pm 1.5\text{VDC}$)

▶ Low Drift Op-Amps

- Internally compensated to minimize drift caused by temperature
 - Typically employed in instrumentation circuits with low-level input signals

Operational amplifier types

- ▶ **Wide Bandwidth Op–Amps**
 - These devices have a very high GB product (i.e., 100MHz) compared to 741–type op–amps (0.3–1.2MHz)
 - These devices are sometimes called video op–amps
- ▶ **Single DC Supply Op–Amps**
 - Devices that operate from a monopolar DC power supply voltage
- ▶ **High–Voltage Op–Amps**
 - Devices that operate at high DC power supply voltages (i.e. $\pm 44\text{VDC}$) compared to most other op–amps ($\pm 6\text{V}$ to $\pm 22\text{V}$)
- ▶ **Multiple Devices**
 - Those that have more than one op–amp in the same package (i.e., dual or quad op–amps)
- ▶ **Instrumentation Op–Amps**
 - These are DC differential amplifiers made with 2–3 internal op–amps
 - Voltage gain is commonly set with external resistors

Families of operational amplifiers

Table 12-1
Families of Operational Amplifiers

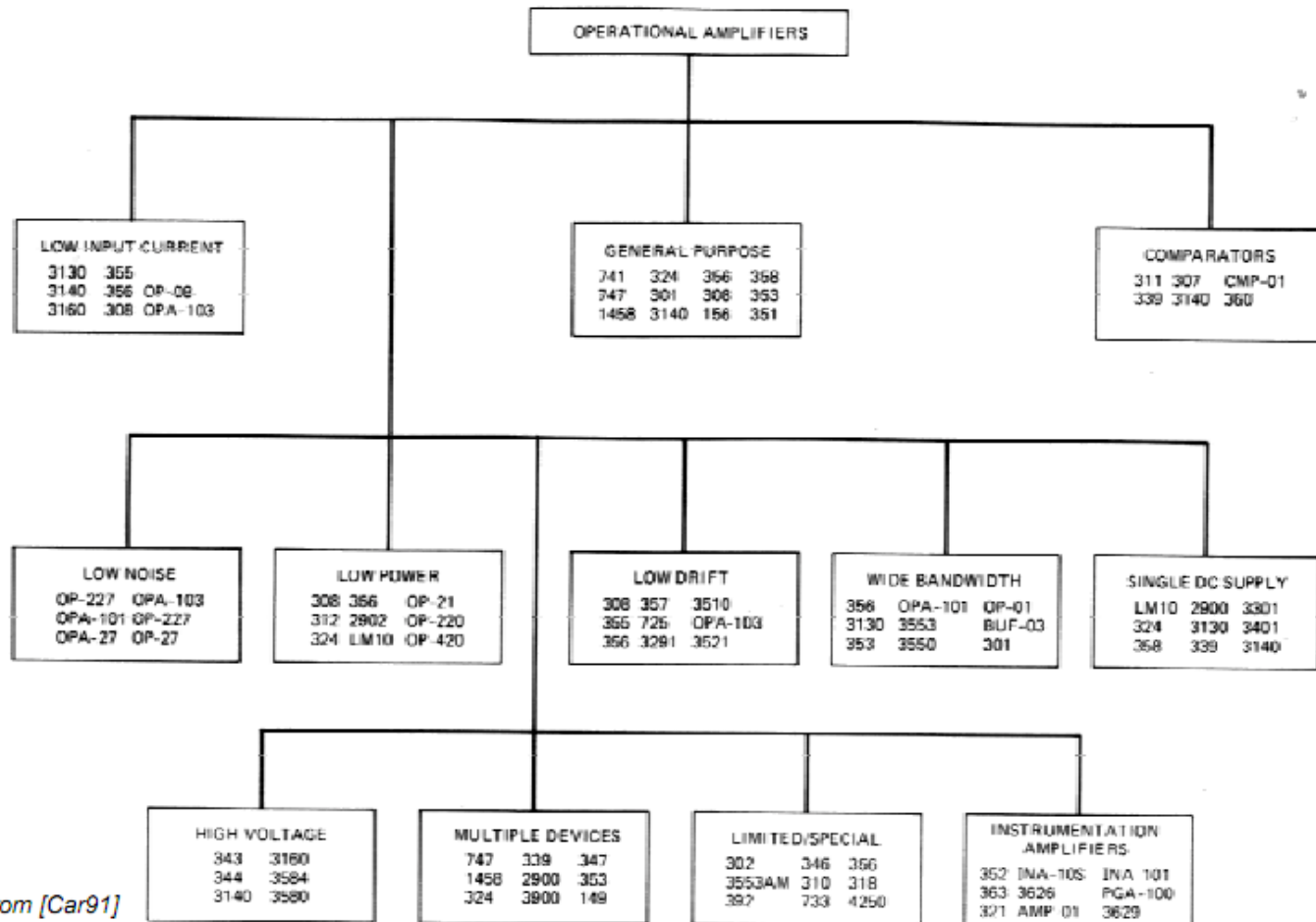

From [Car91]

Op-amp practical circuits

■ Voltage comparator

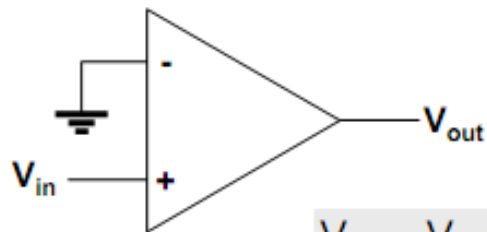

$$V_{out} = V_{CC} \text{sign}(V_{in})$$

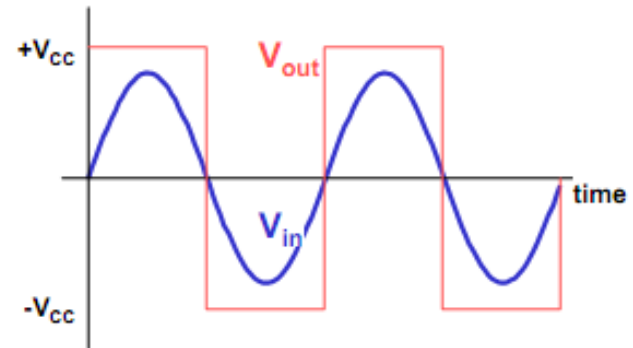

■ Voltage follower

- What is the main use of this circuit?
 - Buffering

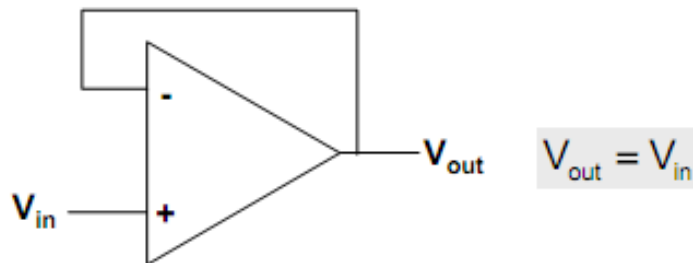

$$V_{out} = V_{in}$$

Inverting and non-inverting amplifiers

■ Non-inverting amplifier

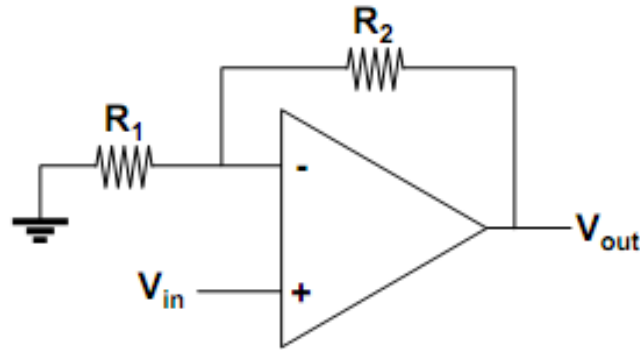

$$V_{out} = \left(1 + \frac{R_2}{R_1}\right) V_{in}$$

■ Inverting amplifier

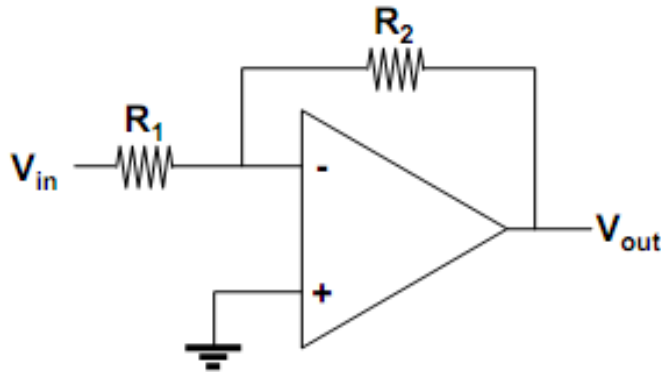

$$V_{out} = -\frac{R_2}{R_1} V_{in}$$

Summing and differential amplifier

■ Summing amplifier

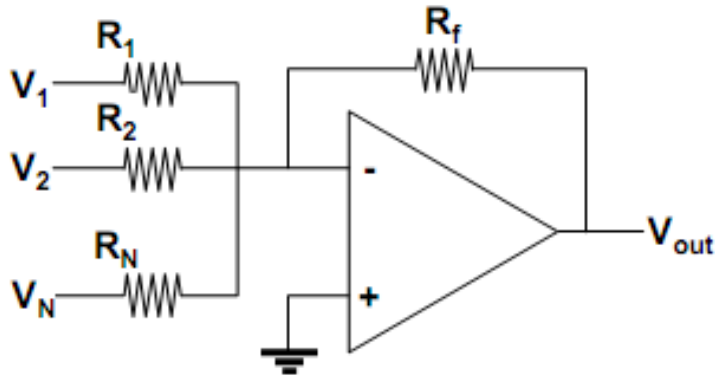

$$V_{out} = - \left(V_1 \frac{R_f}{R_1} + V_2 \frac{R_f}{R_2} + \dots + V_N \frac{R_f}{R_N} \right)$$

■ Differential amplifier

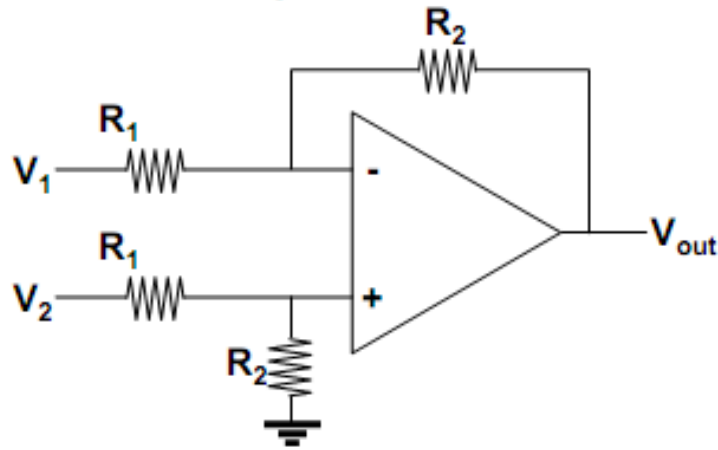

$$V_{out} = \frac{R_2}{R_1} (V_2 - V_1)$$

Integrating and differentiating amplifier

■ Integrating amplifier

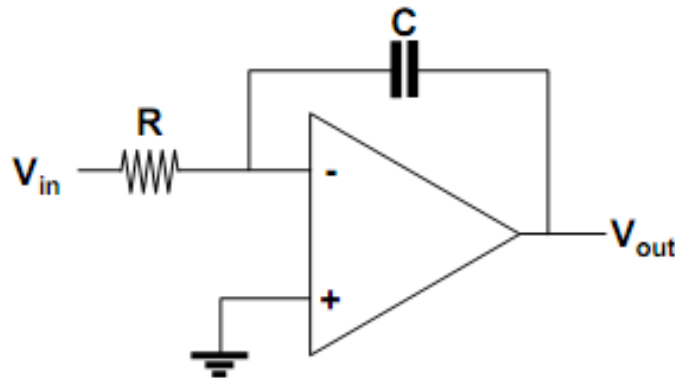

$$V_{out} = -\frac{1}{j\omega CR} V_{in} = -\frac{1}{RC} \int V_{in} dt$$

■ Differentiating amplifier

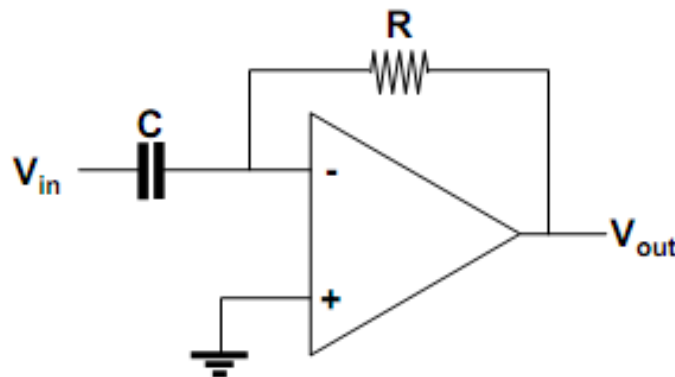

$$V_{out} = -\frac{R}{\frac{1}{j\omega C}} V_{in} = -RC \frac{dV_{in}}{dt}$$

Current to voltage conversion

■ Current-to-voltage

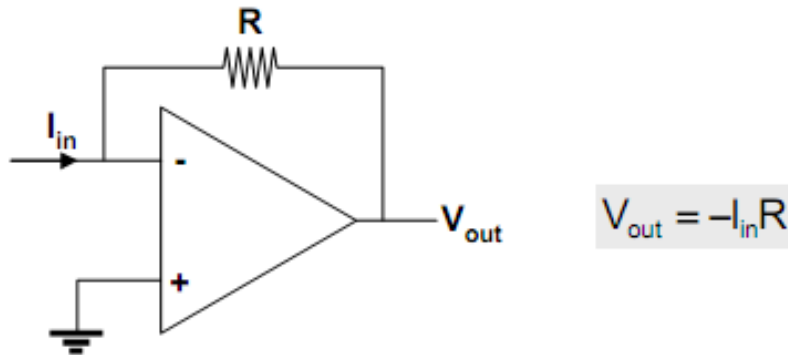

■ Voltage to current

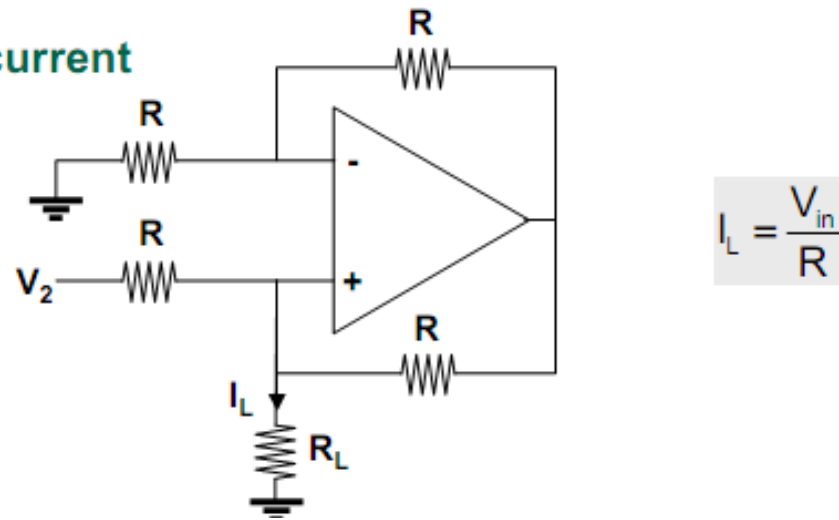

References

- ▶ [1] J. C. Whitaker, 1996, The Electronics Handbook, CRC Press
 - ▶ [2] P. Elgar, 1998, Sensors for Measurement and Control, Addison Wesley Longman, Essex, UK.
 - ▶ [3] R. Pallas–Areny and J. G. Webster, 1991, Sensors and Signal Conditioning, Wiley, New York
- 