

Basic Parameter Extraction

- There are a number of very basic speech parameters which can be easily calculated for use, in simple applications:
 - Short Time Energy
 - Short Time Zero Cross Count (ZCC)
 - Pitch Period
- All of the above parameters are typically estimated for frames of speech between 10 and 20 ms long

Short Time Energy

- The short-time energy of speech may be computed by dividing the speech signal into frames of N samples and computing the total squared values of the signal samples in each frame.
- Splitting the signal into frames can be achieved by multiplying the signal by a suitable window function $w(n)$ $\{n=0, 1, 2, 3, \dots, N-1\}$, which is zero for n outside the range $(0, N-1)$

Rectangular Window

- A simple rectangular window of duration of 12.5 ms is suitable for this purpose. For a window starting at sample m , the short-time energy E_m is defined as

$$E_m = \sum_n [s(n) w(m-n)]^2$$
$$w(n) = \begin{cases} 1 & 0 \leq n \leq N-1 \\ 0 & \textit{otherwise} \end{cases}$$



$$E_m = \sum_n [s(n)]^2 h(m-n)$$
$$h(n) = [w(n)]^2$$

Linear filter representation

- The above equation (see previous slide) can thus be interpreted as



The signal $s(n)^2$ is filtered by a linear filter with impulse response $h(n)$.

The choice of the impulse response $h(n)$ or equivalently the window, determines the nature of the short-time energy representation.

To see how the choice of window affects the short-time energy, let us observe that if $h(n)$ was very long and of constant amplitude E_m would change very little with time

Such a window would be equivalent of a very narrowband lowpass filter. Clearly what is desired is some lowpass filtering, so that the short-time energy reflects the amplitude variations of the speech signal.

We wish to have a short duration window to be responsive to rapid amplitude changes. But a window that is too short will not provide sufficient averaging to produce a smooth energy function.

Note: Rectangular window

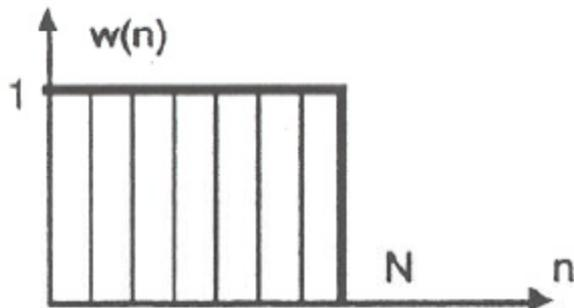

$$w(n) = \begin{cases} 1 & 0 \leq n \leq N-1 \\ 0 & \text{otherwise} \end{cases}$$

$$W(z) = \sum_{n=0}^{N-1} w(n)z^{-n} = 1 + z^{-1} + z^{-2} + z^{-3} + \dots + z^{-(N-1)} = \frac{1 - z^{-N}}{1 - z^{-1}}$$

$$W(\theta) = W(z)|_{z=e^{j\theta}} = \frac{1 - e^{-jN\theta}}{1 - e^{-j\theta}};$$

$$W(\theta) = e^{-j\frac{N-1}{2}\theta} \frac{\text{Sin}\frac{N\theta}{2}}{\text{Sin}\frac{\theta}{2}}$$

↑
↑
Phase term
Magnitude

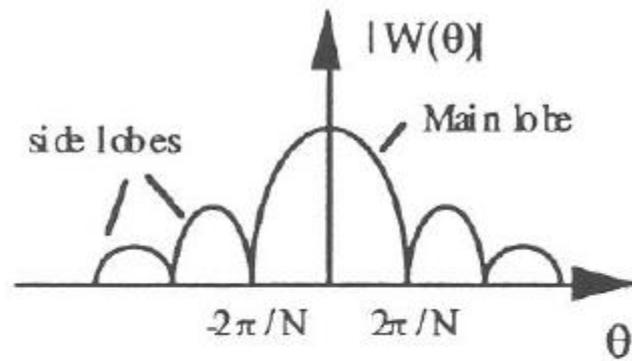

If N is too small, E_m will fluctuate very rapidly depending on exact details of the waveform.

If N is too large, E_m will change very slowly and thus will not adequately reflect the changing properties of the speech signal.

Choice of Window Size

- Unfortunately this implies that no single value of N is entirely satisfactory.
- A suitable practical choice for N is on the order of 100-200 samples for a 10 kHz sampling rate (10-20 ms duration)

Speech with DC offset removed

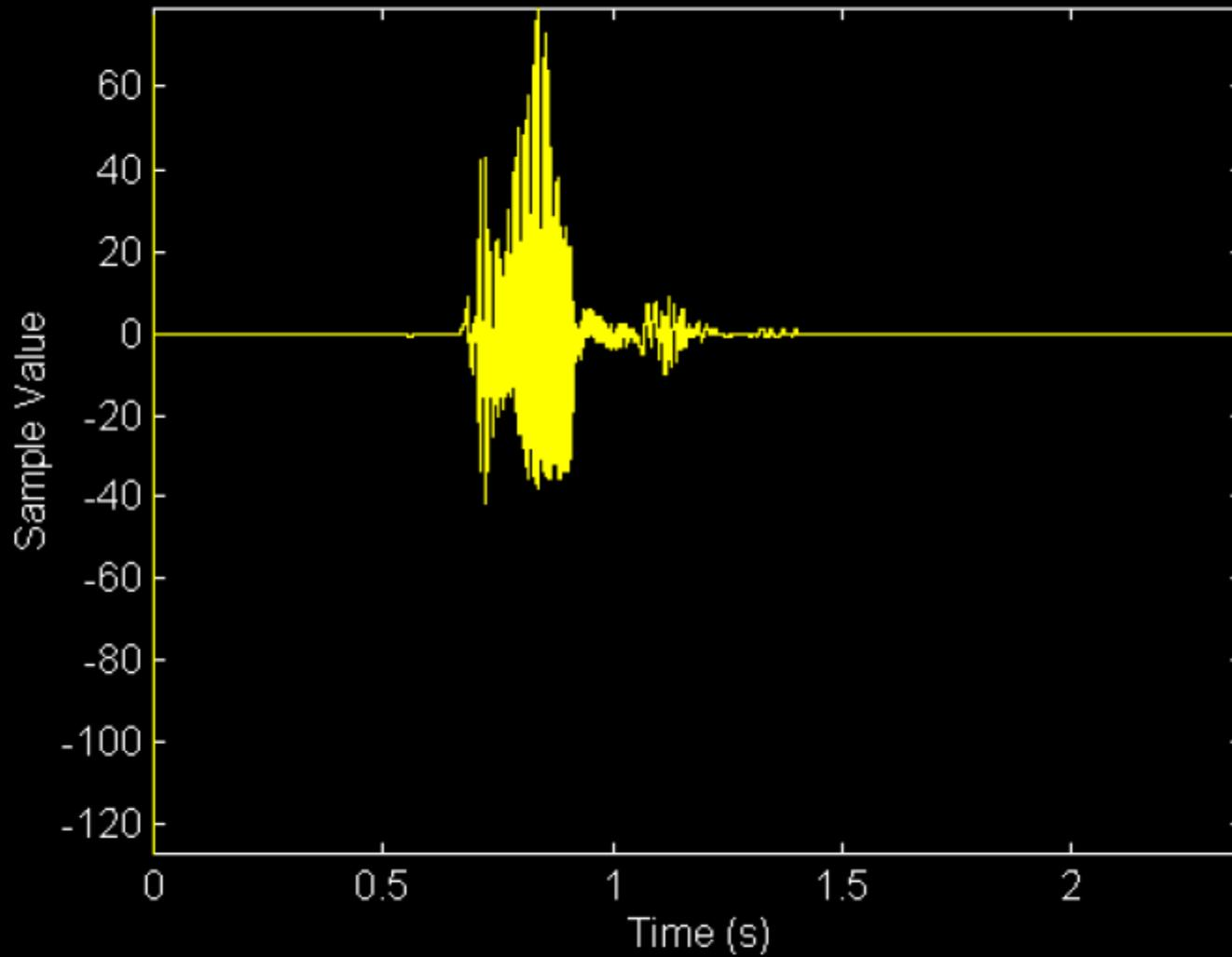

Short Time Average Energy Plot for Utterance

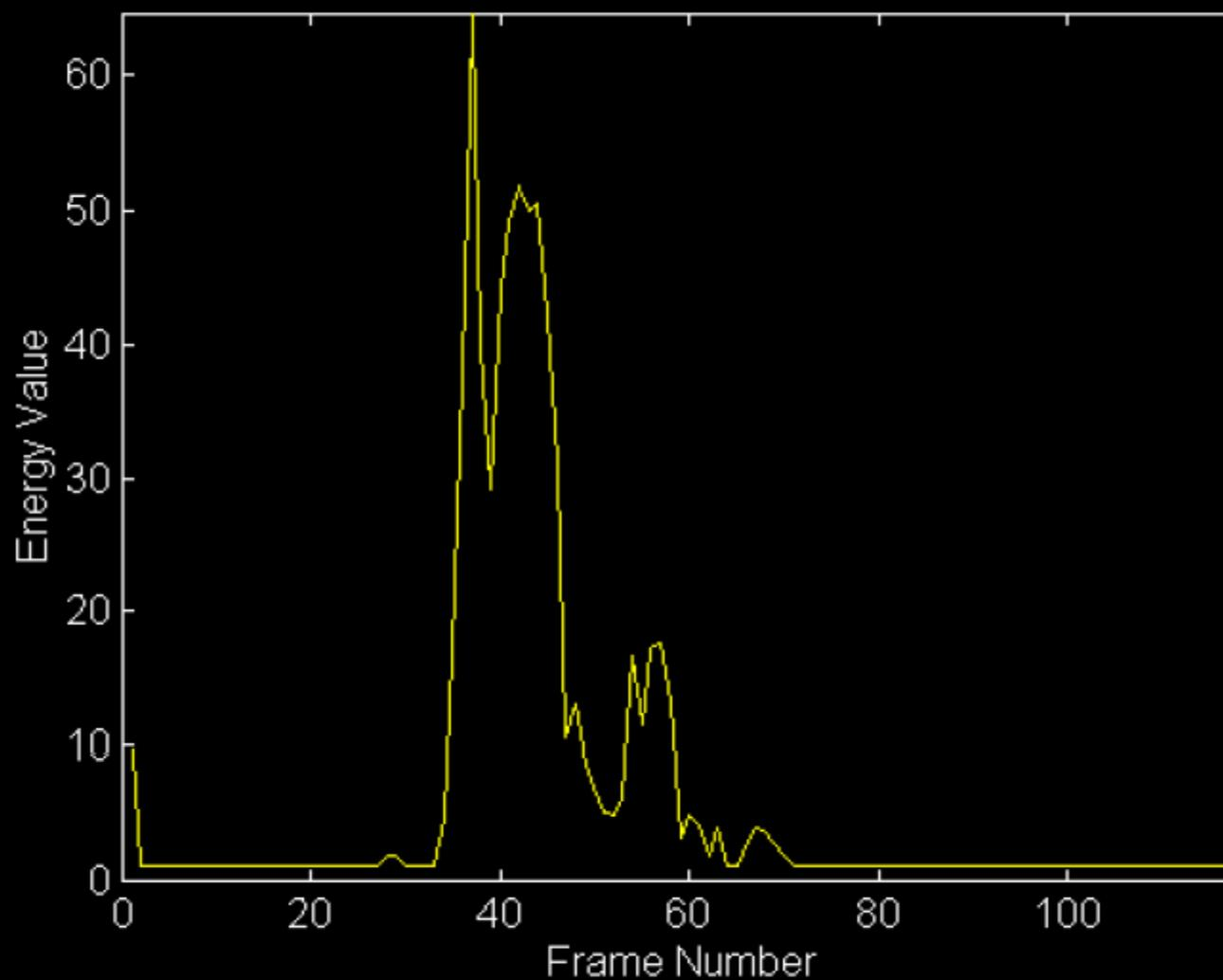

Note that a recursive lowpass filter $H(z)$ can also be used to calculate the short-time energy:

$$H(z) = \frac{1}{1 - az^{-1}} \quad 0 < a < 1$$

It can be easily verified that the frequency response $H(\theta)$ has the desired lowpass property. Such a filter can be implemented by a simple difference equation:

$$E(n) = a E(n-1) + [s(n)]^2$$

$E(n)$ is the energy at the time instant n

The structure for calculating the short-time energy recursively

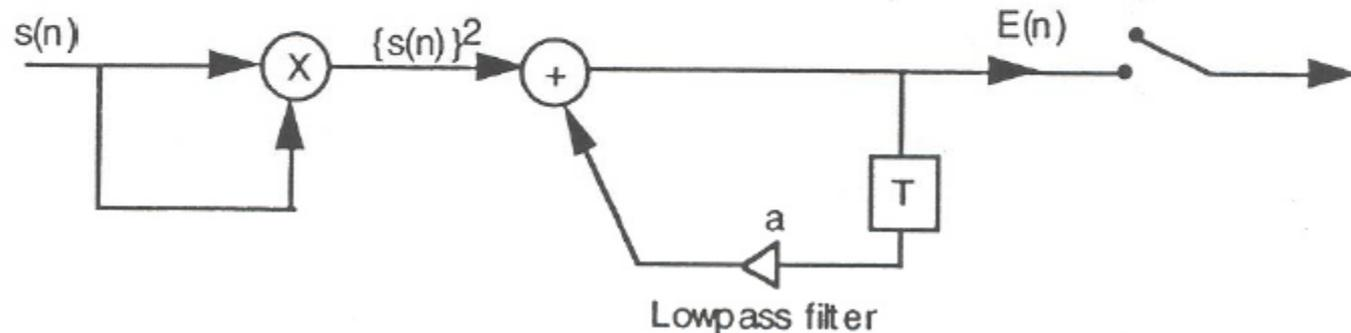

The quantity $E(n)$ must be computed at each sample of input speech signal, even though a much lower sampling rate suffice.

The value 'a' can be calculated using

$$a = e^{(-f_c 2\pi / f_s)}$$

f_c is the cut-off frequency and f_s is the sampling frequency (e.g $f_c=30$ Hz, $f_s = 8000$ Hz)

Short Time Zero Crossing Count

- The Short Time ZCC is calculated for a block of N samples of speech as

$$ZCC_i = \sum_{k=1}^{N-1} 0.5 | \text{sign}(s[k]) - \text{sign}(s[k-1]) |$$

- The ZCC essentially counts how many times the signal crosses the time axis during the frame
 - It “reflects” the frequency content of the frame of speech
 - High ZCC implies high frequency
- It is essential that any constant DC offset is removed from the signal prior to ZCC calculation

Speech with DC offset removed

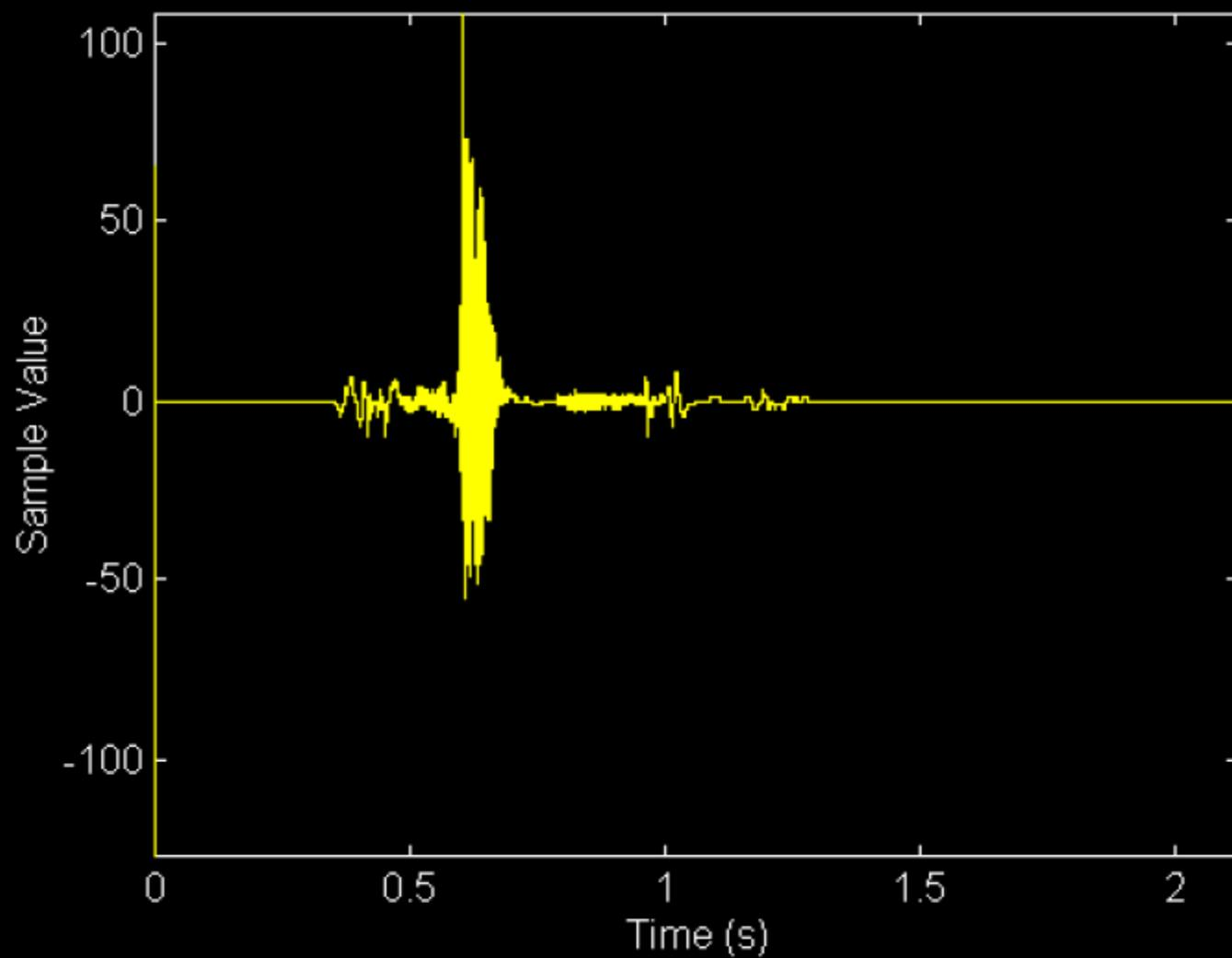

Short Time ZCC Plot for Utterance

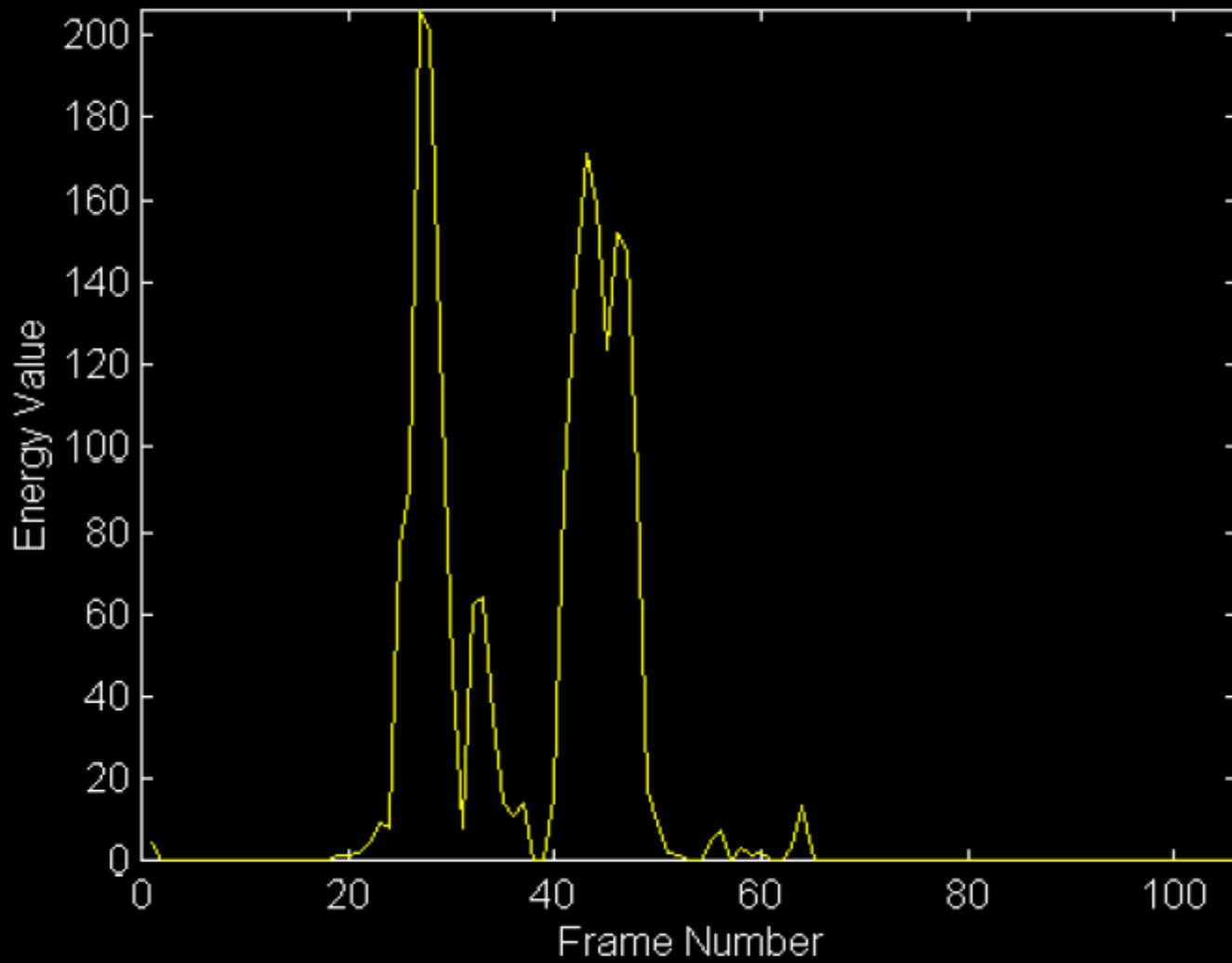

Uses of Energy and ZCC

- Short Time Energy and ZCC can form the basis for :
 - Automated speech “end point” detection
 - Needs to be able to operate with background noise
 - Needs to be able to ignore “short” background noises and intra-word silences (temporal aspects)
 - Voiced\Unvoiced speech detection
 - High Energy + Low ZCC – Voiced Speech
 - Low Energy + High ZCC – Unvoiced Speech
 - Parameters on which simple speech recognition\speaker verification\identification systems could be based

Speech Signal "ONE"

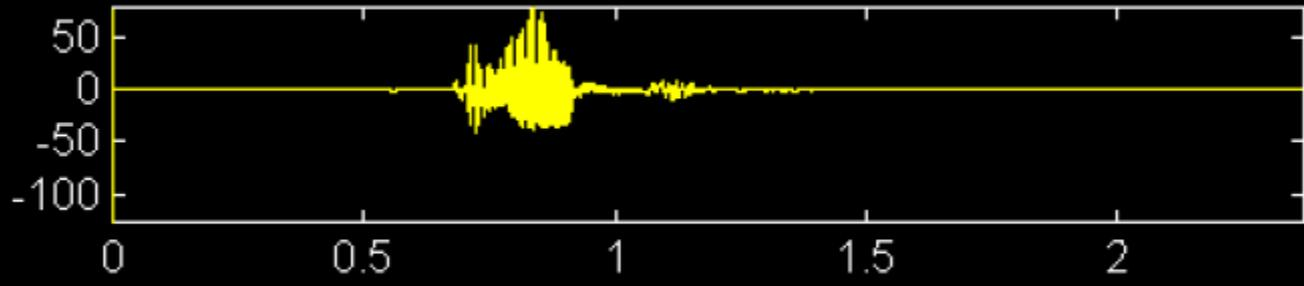

Short Time Energy

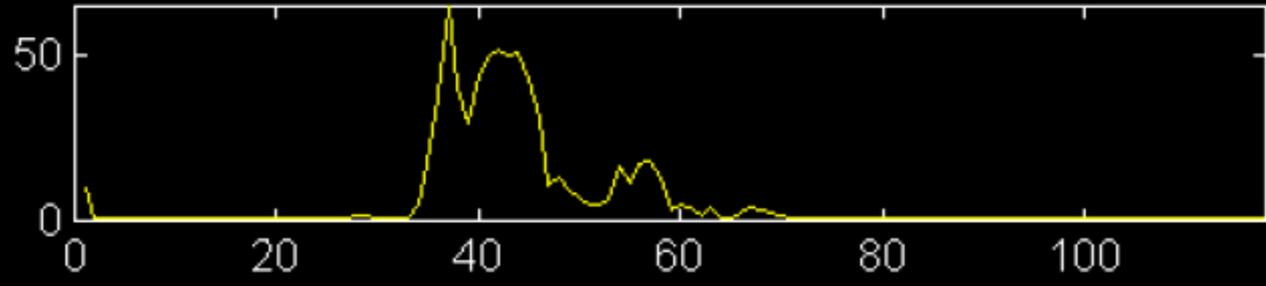

Short Time ZCC

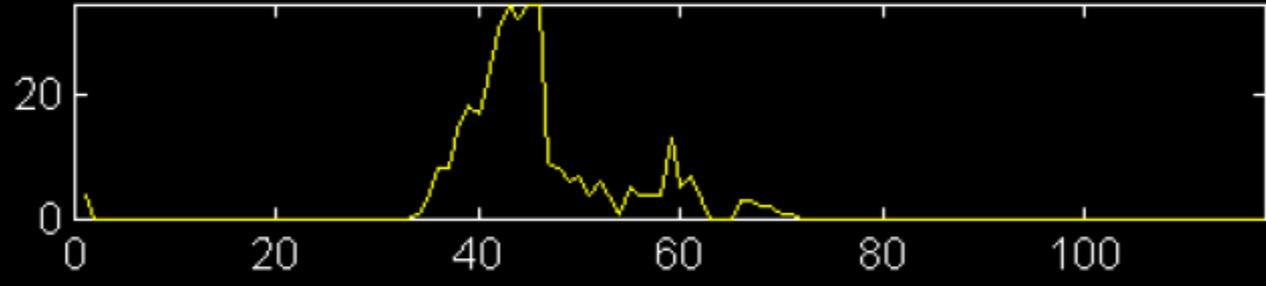

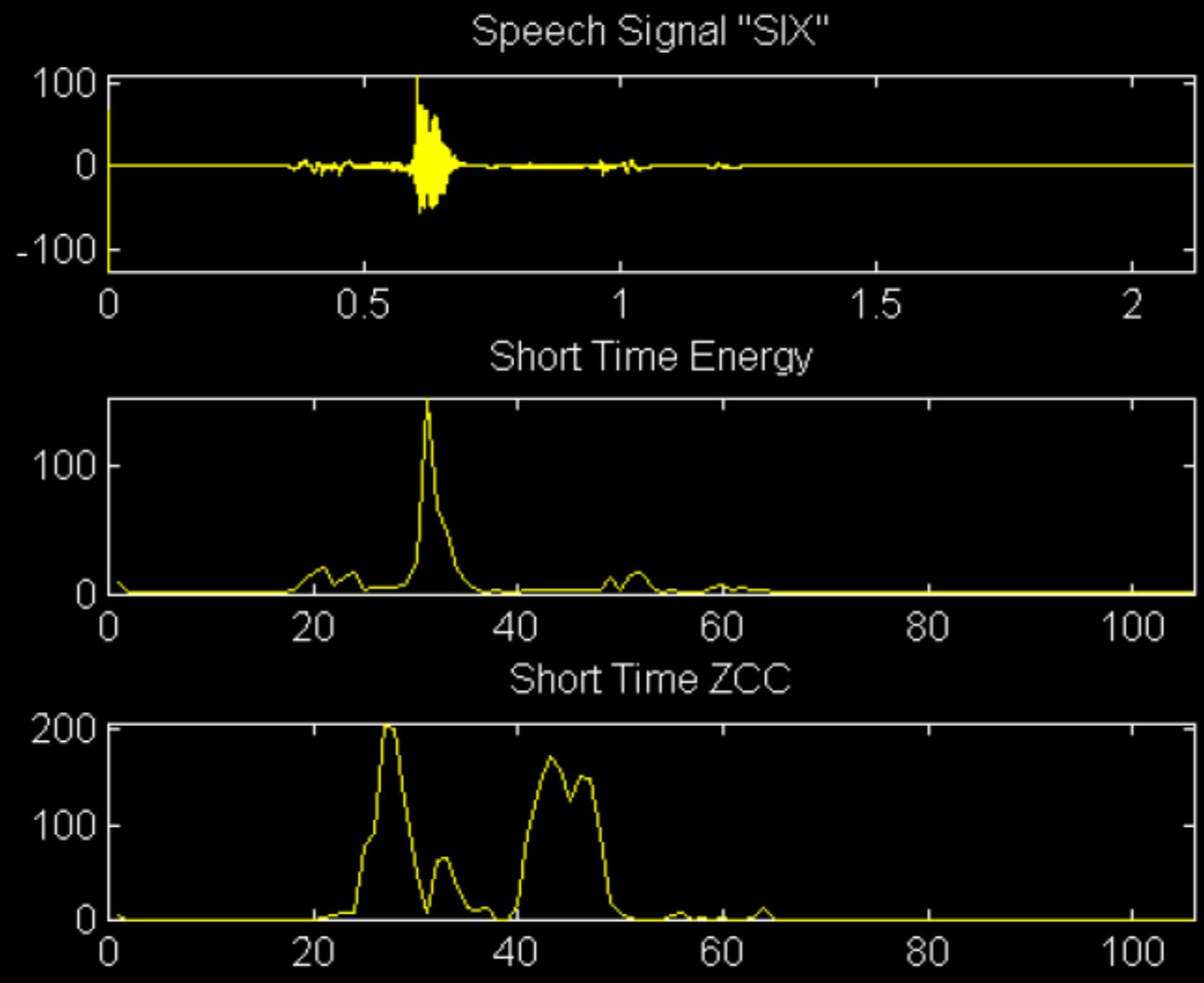

Speech Signal "NINE"

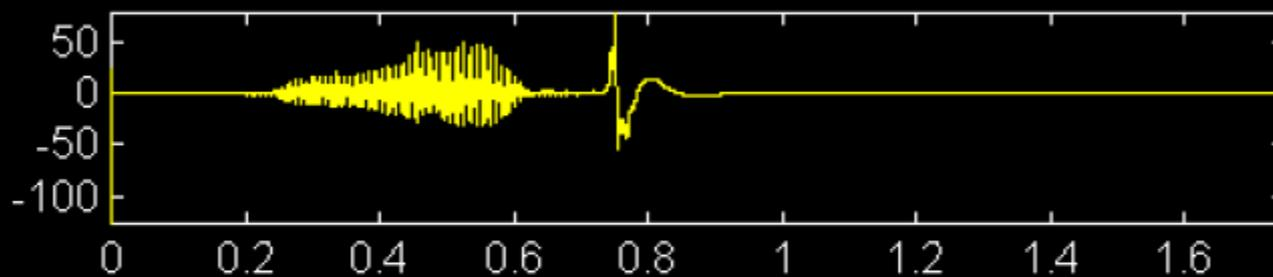

Short Time Energy

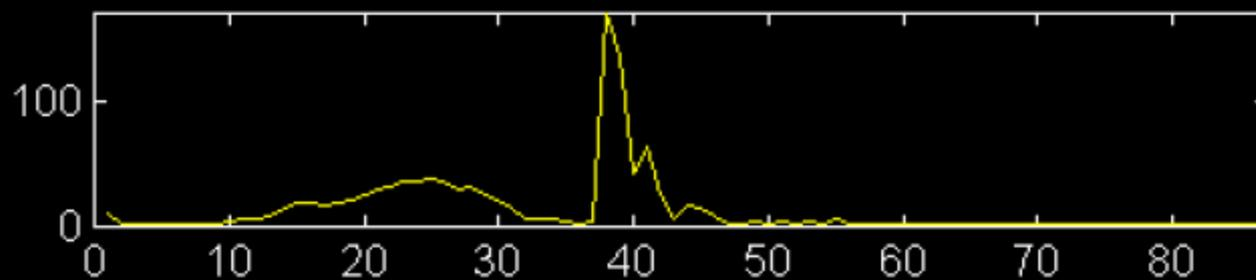

Short Time ZCC

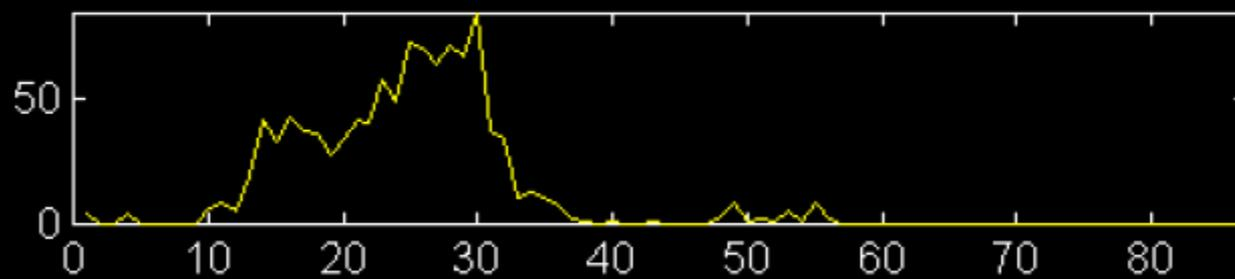

Pitch Period Estimation

- Pitch period is equal to the inverse of the fundamental frequency of vibration of the vocal chords
- It only makes sense to speak about the pitch period of a VOICED frame of speech
- Number of techniques used to determine pitch period
 - Time Domain
 - Frequency Domain

Voiced Segment of Speech

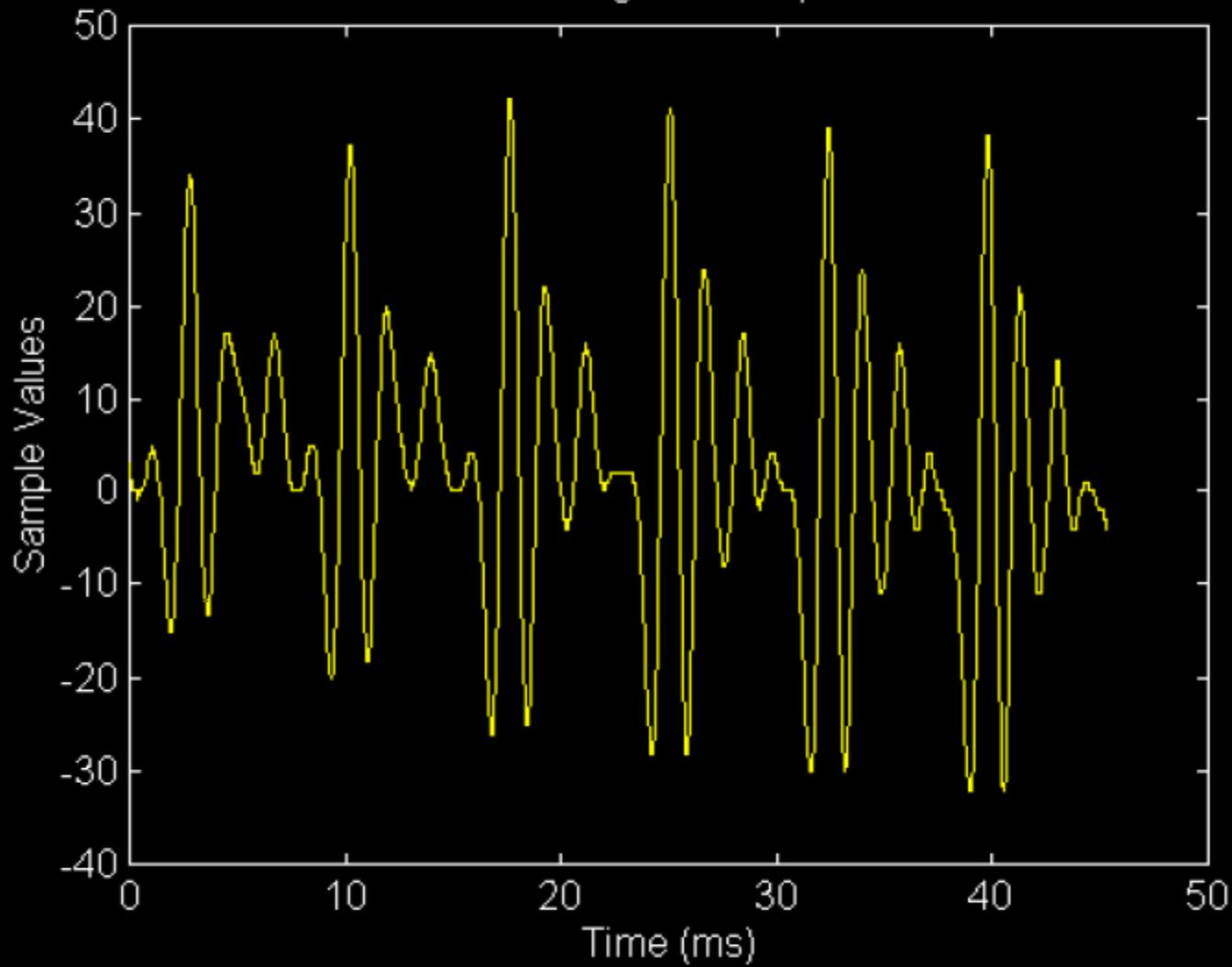

Time Domain Methods

- Since pitch frequency is typically less than 600-700 Hz, the speech signals are first low passed filtered to remove components above this frequency range
- The two most commonly used techniques are:
 - Short Time Autocorrelation Function
 - Average Magnitude Difference Function (AMDF)
- During voiced speech, the speech signal is “quasi-periodic”
- Either technique attempts to determine the period (in samples between “repetitions” of the voiced speech signal)

Autocorrelation Function

- Correlation is a very commonly used technique in DSP to determine the “time difference” between two signals, where one is a “nearly perfect” delayed version of the other
- Autocorrelation is the application of the same technique to determine the unknown “period” of a quasi-periodic signal such as speech
- The autocorrelation function for a delay value of k samples is:

$$\phi(k) = \frac{1}{N} \sum_{n=0}^{N-1} s[n]s[n+k]$$

Autocorrelation Function

- Clearly, $\phi(k=0)$ would be equal to the average energy of the signal $s[n]$ over the N sample frame
- If $s[n]$ was perfectly periodic with a period of P samples then $s[n+P]=s[n]$
- Therefore, $\phi(k=P)=\phi(k=0)=\text{Average Energy}$
- While this is NOT exactly true for speech signals, the autocorrelation function with k equal to the pitch would result in a large value
- For the various k values between 0 and P , the various terms ($s[n]s[n+k]$) in the autocorrelation function would tend to be a mixture of positive and negative values
- These would tend to cancel each other out in the autocorrelation sum to yield very low values for $\phi(k)$

Autocorrelation Function

- This, for a given frame of N samples of VOICED speech, a plot of $\phi(k)$ versus k would exhibit distinct peaks at k values of $0, P, 2P, \dots$, where P is the pitch period
- The graph of $\phi(k)$ would be of quite small values between these peaks
- This pitch period for that frame is simply got by measuring the distance, in samples, between the peaks of the graphs of the autocorrelation function

Autocorrelation Function for Frame

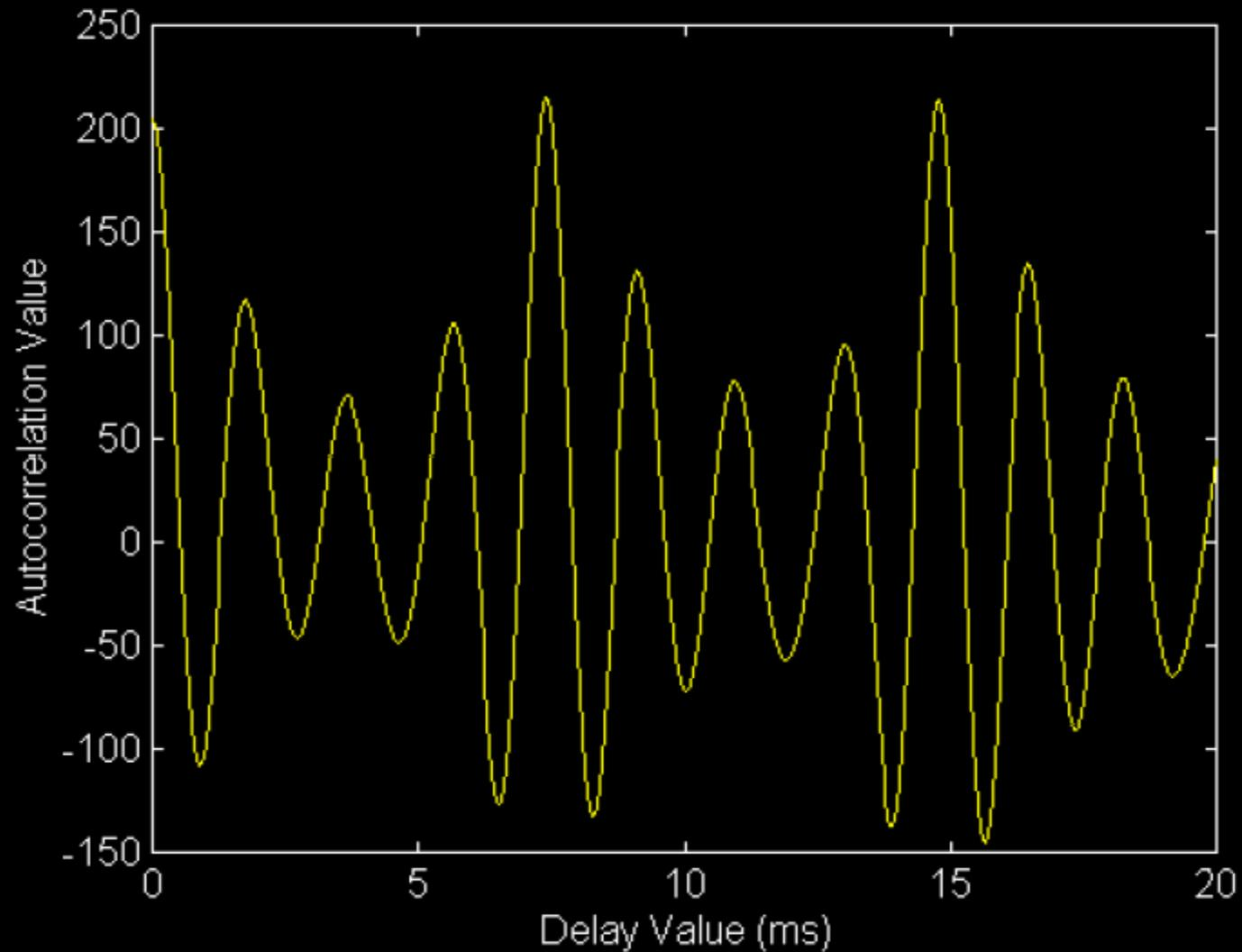

A block diagram of the implementation of the autocorrelation function is shown below:

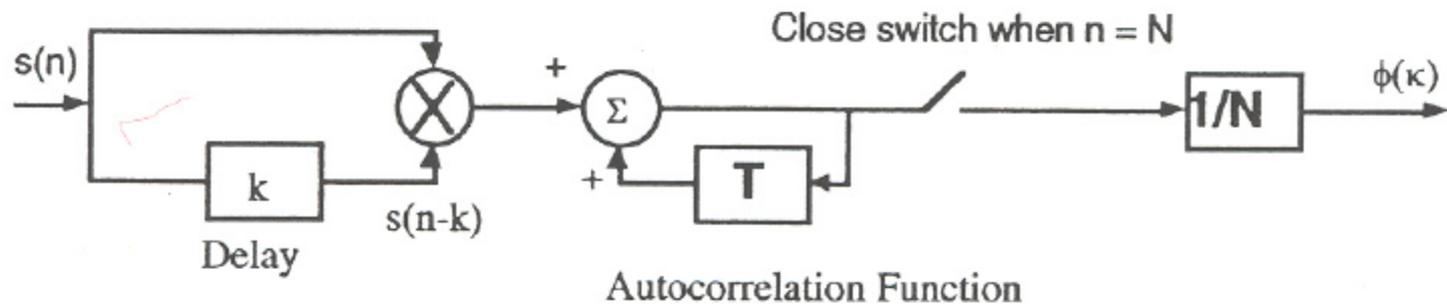

$$\phi(k) = \frac{1}{N} \sum_{n=0}^{N-1} s[n]s[n+k]$$

Average Magnitude Difference Function

- The AMDF is similar but opposite to the Autocorrelation Function
- For a delay of k samples, the AMDF is defined as

$$D(k) = \frac{1}{N} \sum_{n=0}^{N-1} |s[n] - s[n+k]|$$

Average Magnitude Difference Function

- For a given frame of VOICED speech, a plot of AMDF ($D(k)$) versus different values of delays (k), will exhibit deep “nulls” at $k=0, P, 2P, \dots$
- If is used as an alternative to autocorrelation as on some processor architectures, it may be less computationally intensive to implement
- Care should be taken with both techniques to support the “overlap” into adjacent frames introduced by the the autocorrelation and AMDF

Average Magnitude Difference Function for Frame

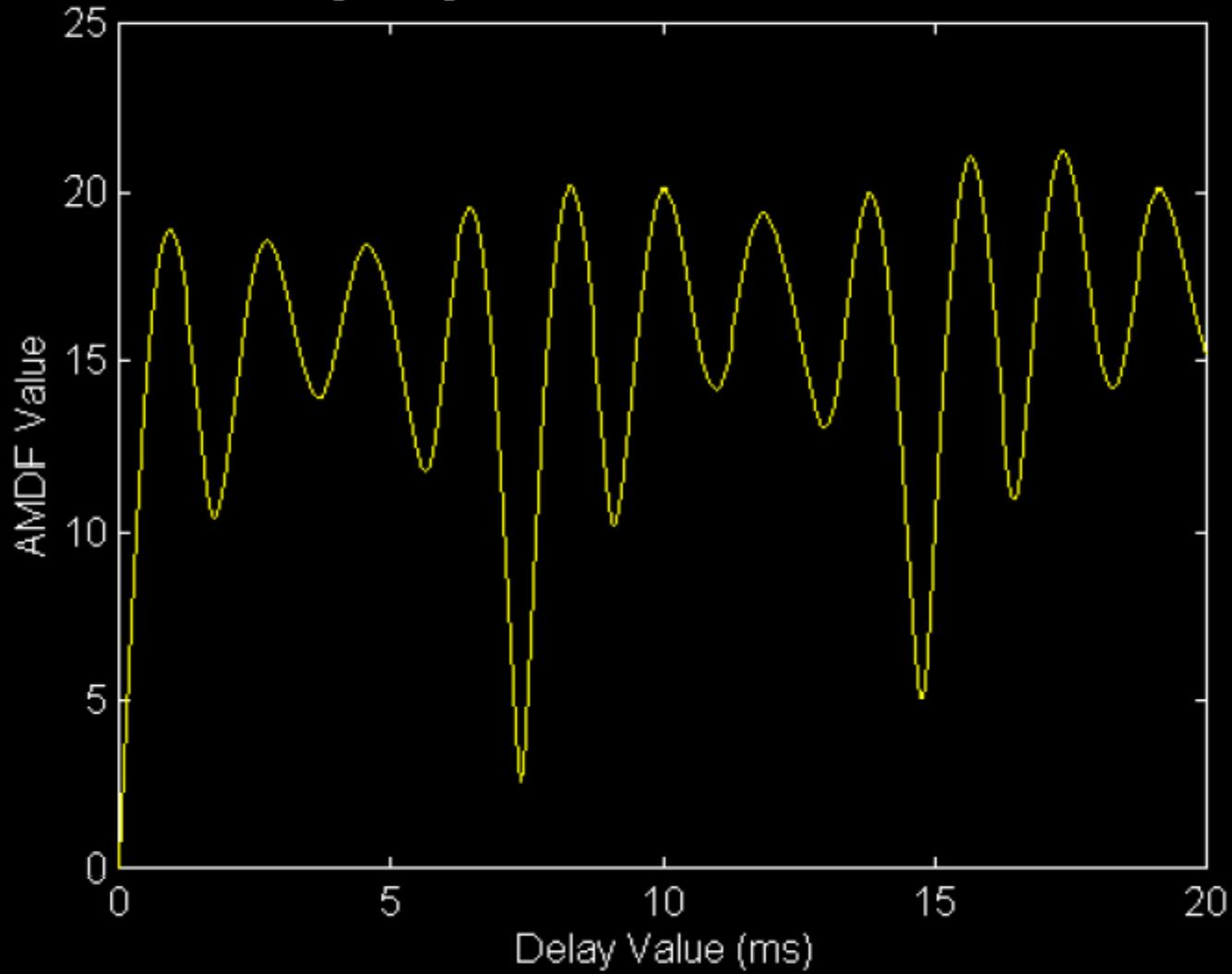

A block diagram implementation of the AMDF function:

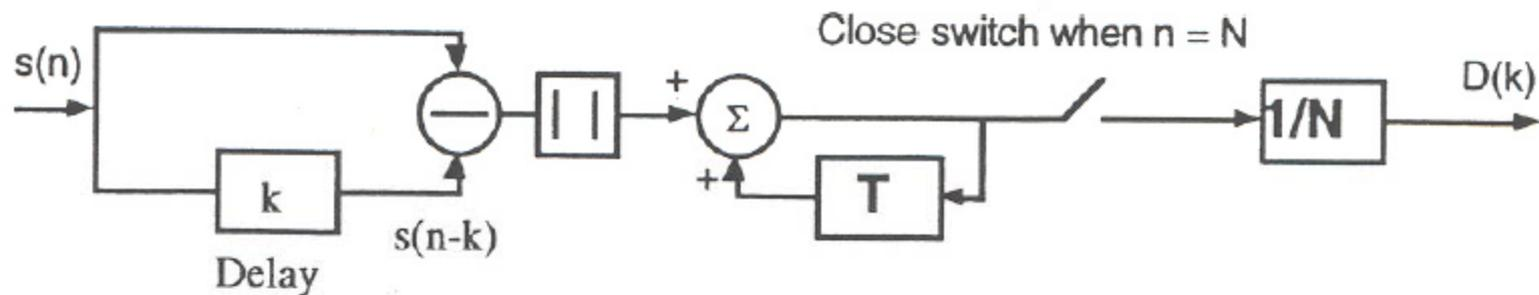

$$D(k) = \frac{1}{N} \sum_{n=0}^{N-1} |s[n] - s[n+k]|$$

Pre-emphasis Filter

- Recall transfer function of vocal tract:

$$\frac{S(z)}{E(z)} = A_v \frac{1}{(1-z^{-1})^2} \frac{1}{1 + \sum_{k=1}^p a_k z^{-k}} (1-z^{-1})$$

- There is an -6dB/octave trend as frequency increases .
- It is desirable to compensate for this by pre-processing the speech. This has an effect of cancelling out the effect of glottis and is known as pre-emphasis.

Pre-emphasis

- The high-pass filtering function can be achieved by use of the following difference equation:

$$y(n) = s(n) - as(n - 1)$$

- Normally a is chosen between 0.9 and 1

Exercise: Pre-emphasis filter

1- Use MATLAB to plot the frequency response of a pre-emphasis filter with the following transfer function:

$$H(z) = 1 - 0.95z^{-1}$$

2 – Plot the spectra of a frame of speech before and after pre-emphasis filter has been applied?

Short-time Fourier Transfer - review

- Spectrogram maybe attained through use of STFT.
- FT is carried out on a short sequence of signal
- The signal maybe windowed e.g. Hamming window
- Overlapping should be also carried out.
- Following formula for calculating STFT with window w of length N :

$$STFT(k, b) = \sum_{m=0}^{N-1} w(m-b)s(m)e^{\frac{-j2\pi km}{N}}$$

STFT Exercise

- 1. Generate a signal composed of 4 tones of different frequencies**
 - Two tones should be present constantly and other two tones occurring at different times.
 - signal should be about 1 sec in length in total and tones should have different levels.
- 2. Write a Matlab script to perform the STFT**
 - include Hamming window
 - 50% overlapping of frames
- 3. Plot spectrogram of a signal**
- 4. Investigate effect of**
 - changing frame size
 - changing number of points in FFT
- 5. Record your own speech signal and generate spectrograms.**

Exercises ...

- Find and plot short-time energy of your recorded speech.
- Find and plot Short-Time Zero-Crossing Counts (ZCC) of your speech signal
- Use Auto-Correlation and Average Magnitude functions to Find and plot Fundamental frequency (Pitch period) of yourself.