



Faculty of Engineering and Technology
Electrical and Computer Engineering Department

Circuits Lab
(ENEE2102)

Prepared By
Electrical and Computer Engineering Department

2018

Table of contents

Experiment #1	Introduction to PSPICE and report writing	4
Experiment #2	Introduction to measurements and lab devices	30
Experiment #3	Simple Resistive Circuits	42
Experiment #4	Network theorems	49
Experiment #5	First and second order circuits	56
Experiment #6	Flux produced by field coils	68
Experiment #7	Impedance and sinusoidal steady state	73
Experiment #8	AC & DC power analysis and design	82
Experiment #9	Passive filters analysis	90
Experiment #10	Active filters analysis	102
Experiment #11	Two port networks	109
Data Tables		116

Lab Safety Instructions and Rules

General Behavior

- During the laboratory session, it is required to have an experimental setup checked and approved by the instructor before starting data collection.
- Never hurry. Work deliberately and carefully.
- Smoking, eating, drinking and use of cell phones is not allowed during the laboratory session.
- Please don't yell, scream, or make any sudden loud noises that could startle others who are concentrating on their work.
- When you are done with your experiment or project, all components must be dismantled and returned to proper locations.
- Dress properly during all laboratory activities. Long hair, dangling jewelry, and loose or baggy clothing are a hazard in the laboratory. Long hair must be tied back and dangling jewelry and loose or baggy clothing must be secured.



First Aid & fire

- First aid equipment and fire extinguisher are available in the lab, ask your instructor about the nearest kit.



Academic Instructions for Performing Experiments

- Each Student should prepare for the lab by reviewing the theoretical background for the circuits under test.
- Students will work in groups of 2-3 students maximum.
- Each group should prepare a report and submit it at the beginning of next lab session.
- **Data sheet should be signed by the instructor before you leave the laboratory, otherwise your report will not be accepted.**

Experiment 1

Introduction to PSPICE and report writing

➤ **Objectives:**

This experiment provides an introduction to the basics of circuit's simulation using "PSPICE 9.1 schematic" which will be used in pre-labs through this course. Also, an introduction to technical report writing is provided.

➤ **Equipment Required:**

1. Personal computer with PSPICE 9.1 and Microsoft word.

➤ **Introduction:**

Through the course this lab students have to prepare for experiments by studying theoretical background related to experiment, and by doing pre-labs which includes simulation of circuits.

Computer simulation programs, such as PSPICE, simulates the behavior of electric circuits on a digital computer and tries to emulate both the signal generators and measurement equipment such as multimeters, oscilloscopes, and curve tracers. Though, by using PSPICE it is like you have a virtual circuit lab on your personal computer.

Also, by using PSPICE students can easily subject the circuit to various stimuli (such as input signals and power supply variations) and to see the results plotted out graphically using PSPICE's post processor called Probe. Therefore, students can obtain results before they come to lab, and the laboratory experiments become reinforcement to the subject matter at hand.

We will be using PSPICE 9.1 student version for simulation, and you can use newer versions provided by OrCAD. The first part of this experiment is dedicated to introduce students to the different applications of PSPICE that are related to the lab.

The second part of this experiment is dedicated to introduce students to the guidelines of report writing. The Bachelor of Science degree in Electrical Engineering involves numerous courses that require written reports. These courses also include laboratories, which require reports too. The fact is, once you graduate, industry will require you to write well. In some cases, you will be involved in writing proposals or possibly final design reports. Certainly,

you will always be required to write short reports and memos detailing your activities. The second part of this experiment is dedicated to introduce you to the basic guidelines of report writing.

➤ **Installing PSPICE 9.1**

- To download PSPICE 9.1 student version, visit the following link:

<http://www.electronics-lab.com/downloads/circutedesignsimulation/?page=5>

You will find a list of programs, scroll down until you see **PSPICE 9.1 Student Version**, then click download. The setup is straight forward, however, in case you needed help check the following video and follow steps.

<https://www.youtube.com/watch?v=tCFjjHY94Ro>

➤ **Building and simulating circuits**

- To open PSPICE 9.1, search your computer for “**Schematic**” and open the program. This is shown in figure.1 for windows 10 users. **Note: zoom in to see figure details if not clear.**

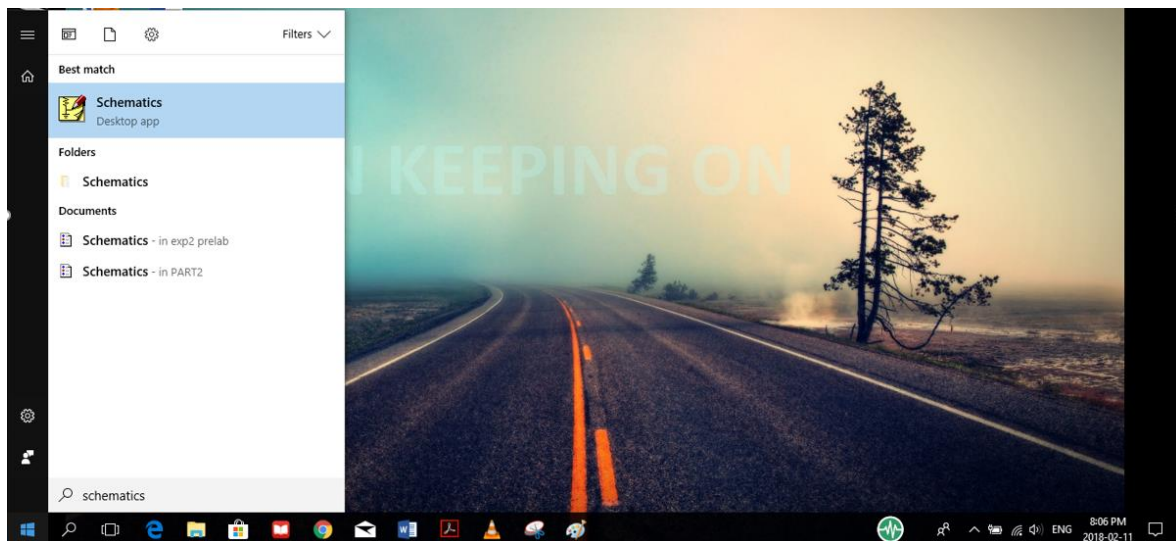

Figure.1

- Click on Schematics icon, then you will see the window shown on figure.2

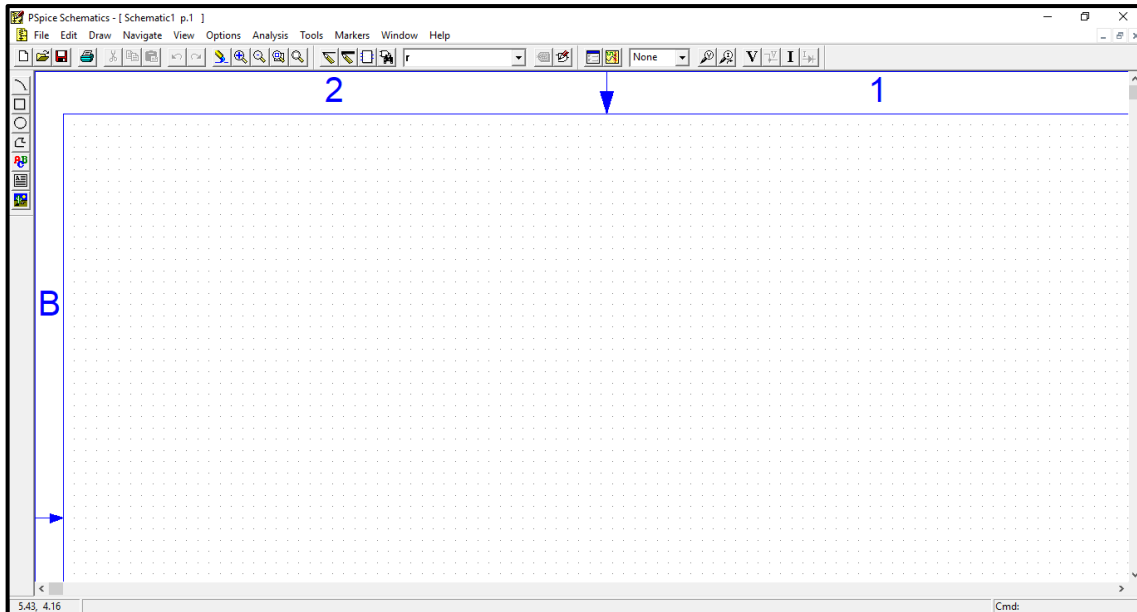

Figure.2

- To build the circuit of figure.3 on PSPICE, click on “get new part” icon shown in figure.4:

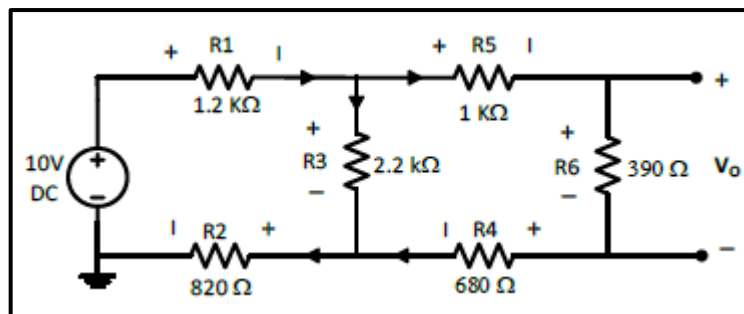

Figure.3

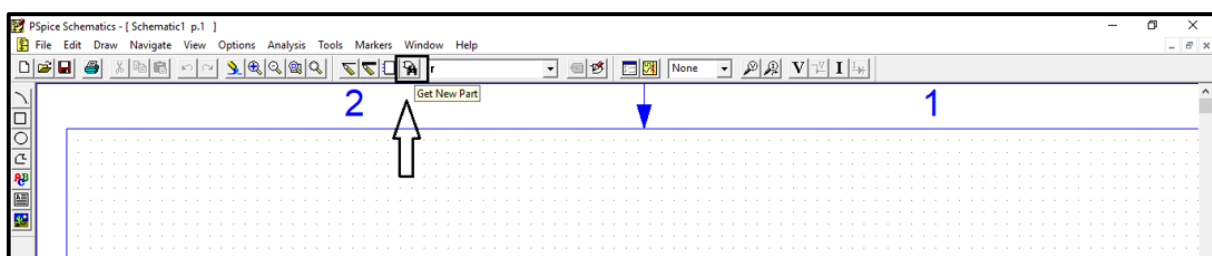

Figure.4

- When you click on get new part icon, you will see the window shown on the left side in figure.5. This is a list of all components available in the program. Click on “advanced” so you can see the picture of part you want to add as shown on the right side in figure.5.

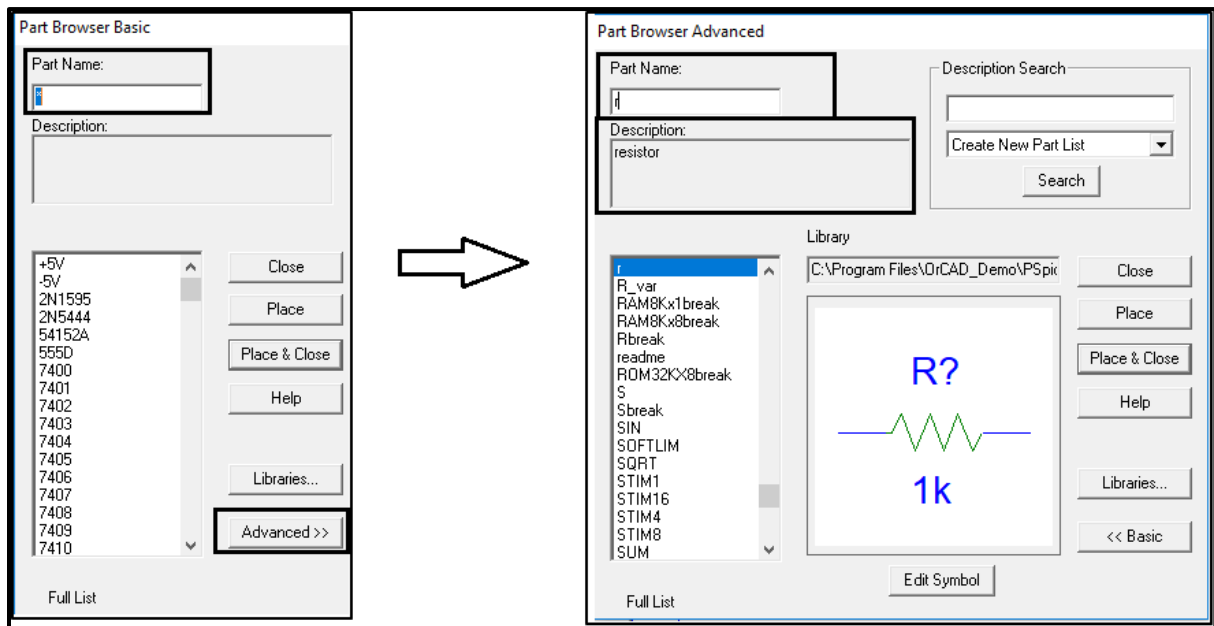

Figure.5

- To add a circuit part, you can search by typing part name in the specified field. After finding the part you want, click on “place and close”, then click wherever you want to add a part. After you finish adding components, click on “Esc” on your keyboard to end the mode.
- Note that each circuit element in PSPICE have a specific name that might be different from its name in circuit analysis. Table.1 provides the names of mostly used circuit elements in the circuit lab.

Table.1

Circuit element	Part name in PSPICE
Resistor	R
Capacitor	C
Inductor	L
DC Voltage source	vdc
DC Current source	Idc
Periodic square voltage source	vpulse
AC Voltage source: two types	vsin (sinusoidal voltage source used in transient analysis)
	vac (variable frequency source used in ac sweep analysis)
ground	gnd_analog
Operational amplifier	ua741

- Note that when you place parts, each circuit part in PSPICE has a name and a value as shown in figure.6 Always make sure to place circuit parts in PSPICE in a similar way to the circuit given in manual. For example, check the way the parts are placed in figure.6.

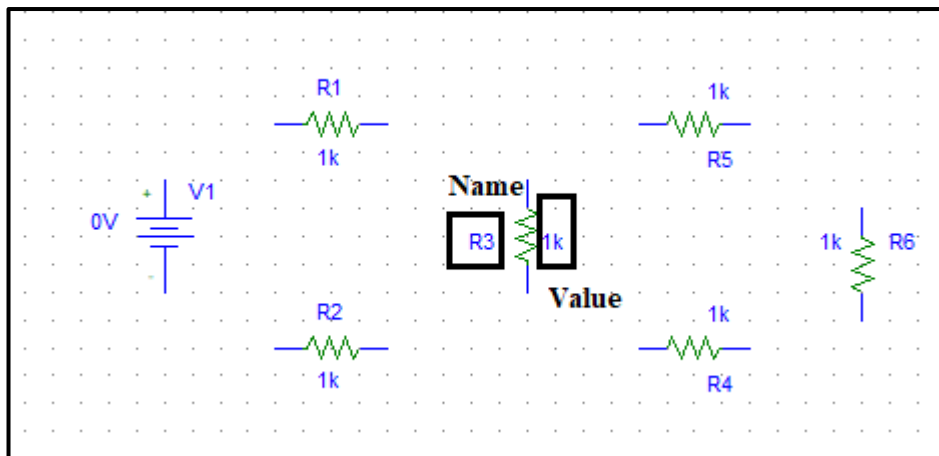

Figure.6

- To connect the components, click on “draw wire” icon shown in figure.7, a **common mistake** that students do is clicking on “draw bus” icon which is next to “draw wire”. Avoid doing this mistake!
- Also avoid drawing wire over components (shorting parts). Click where you want each vertex of the wire. Each click ends a wire segment and starts a new one

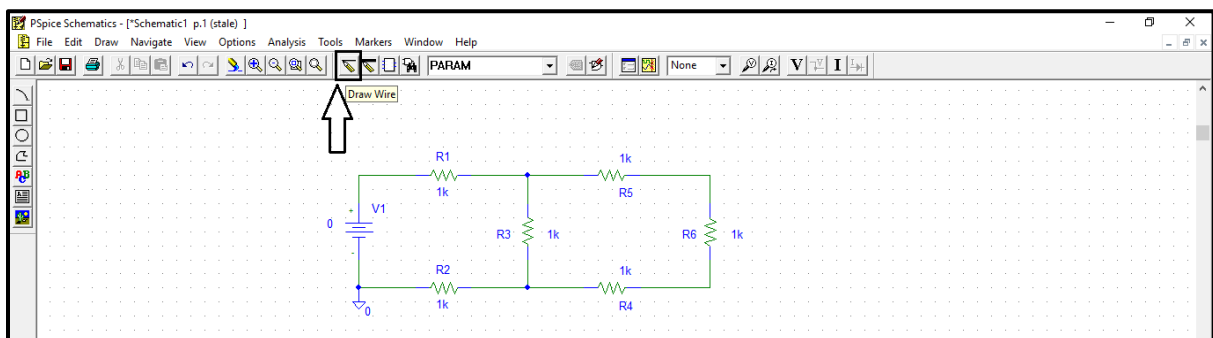

Figure.7

- To change a part value e.g. resistance, voltage source ... etc. double click on its value and the window in figure.8 will show up, type the value you want inside the box then click ok.

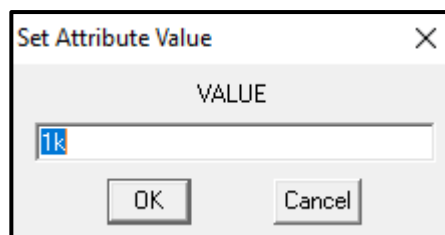

Figure.8

- When elements such as resistors and voltage sources are given values, it is convenient to use unit prefixes. PSPICE supports the prefixes listed in Table.2. Note that the letter must immediately follow the value – no spaces. Also, PSPICE is case insensitive so, there is no difference between 1M and 1m in PSPICE.

Table.2

PSPICE Unit Prefixes		
K - kilo - 10^3	MEG - mega - 10^6	G - giga - 10^9
M - Millie - 10^{-3}	U - micro - 10^{-6}	N - Nano - 10^{-9}

- PSPICE requires that all schematics have a ground**, the voltage there will be zero and all other node voltages are referenced to it. **If you do not place a ground, you will get an error and will not be able to simulate your circuit.** The part you need is either the analog ground (GND_analog) or the earth ground (GND_earth) which are equivalent, you can get them from “get new part option”. In this example, we used GND_analog.
- Your schematic is finished now and ready for saving, click on “save” then on “simulate” button as shown in figure.9.

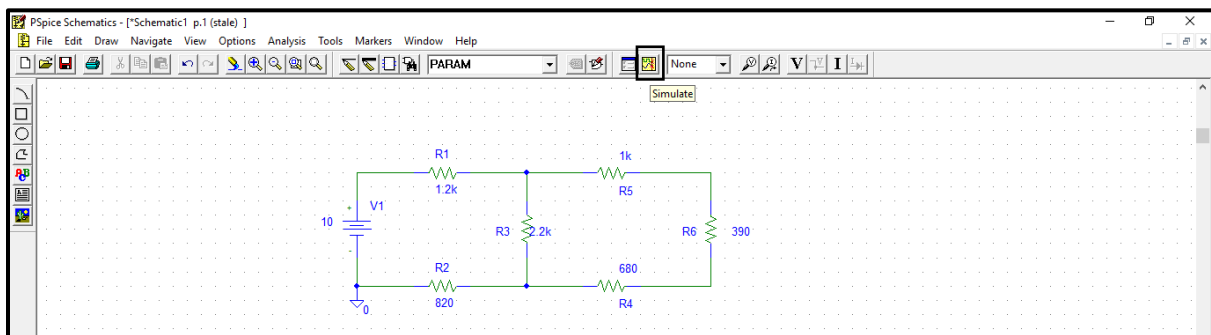

Figure.9

- When you click on “simulate” button the window shown in figure.10 will show up (simulation output window), if your circuit doesn’t have any errors you will see the message in the box in figure.10.

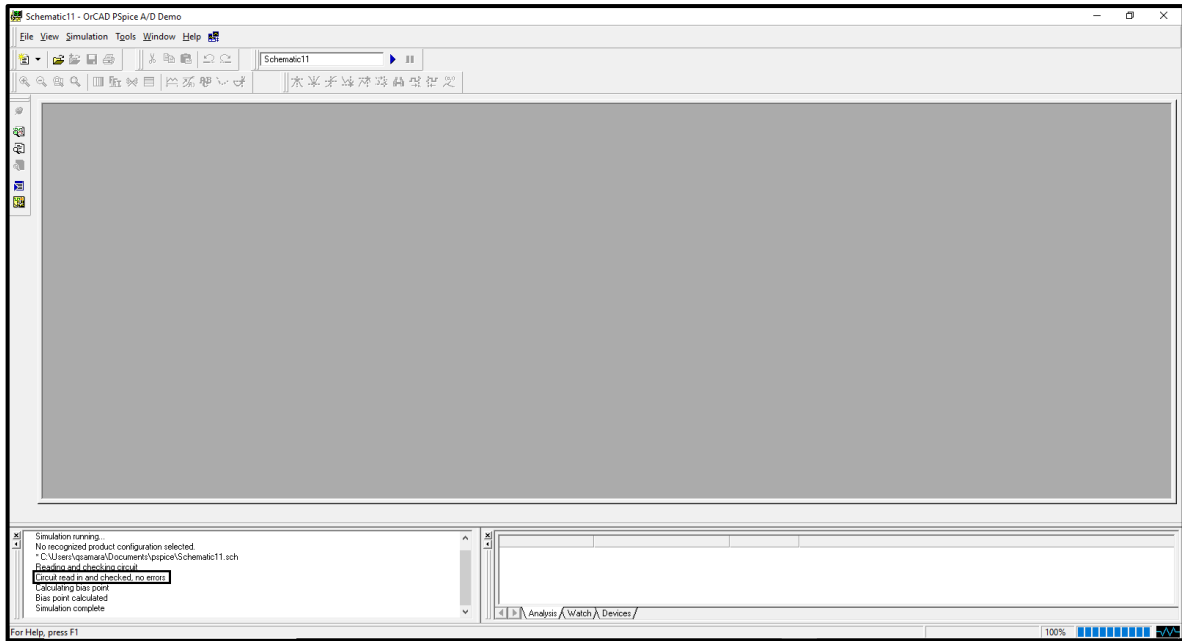

Figure.10

- Return to the schematics window and click on “V” and “I” buttons shown in figure.11. By clicking on these buttons, PSPICE displays the voltage on each node “with respect to ground” and the current on each branch.

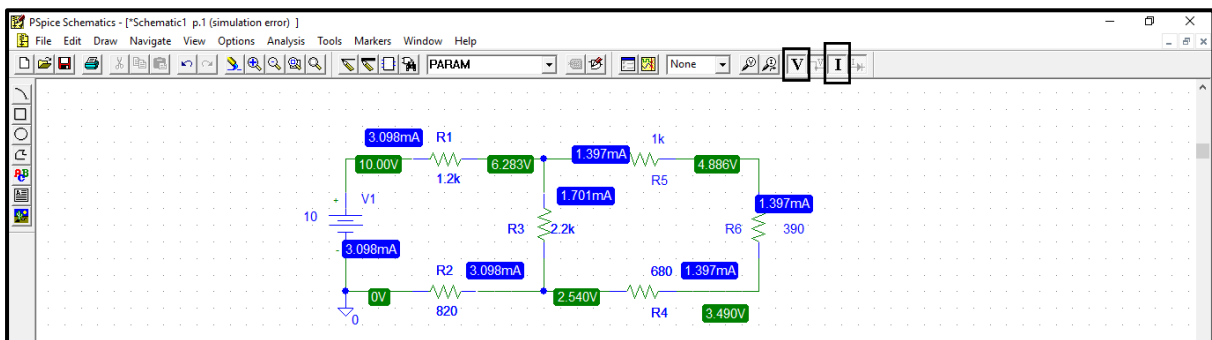

Figure.11

- The Passive Sign Convention and PSPICE:**

All currents and voltages in PSPICE and Schematics obey the passive sign convention shown in Figure.12. The voltage across the element is defined positive at node 1 with respect to node 2, and current is entering a device from its “1” end and leaving its “2” end.

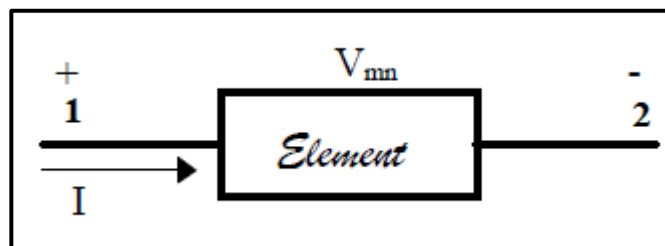

Figure.12

All two leaved passive components have an **implied** “1” end and a “2” end (not visible on schematic). Whenever you place a component, it takes a default position, for example, a resistor, capacitor, or inductor will take a default position with its “1” end to the left as shown in figure13-(a). A component may be rotated by activating it, then right-clicking and selecting Rotate, or by typing the letter “r” (see b). Each rotation moves the component counterclockwise by 90°. To get the “1” end facing up, you must rotate the component 3 times from its default position as indicated in (c).

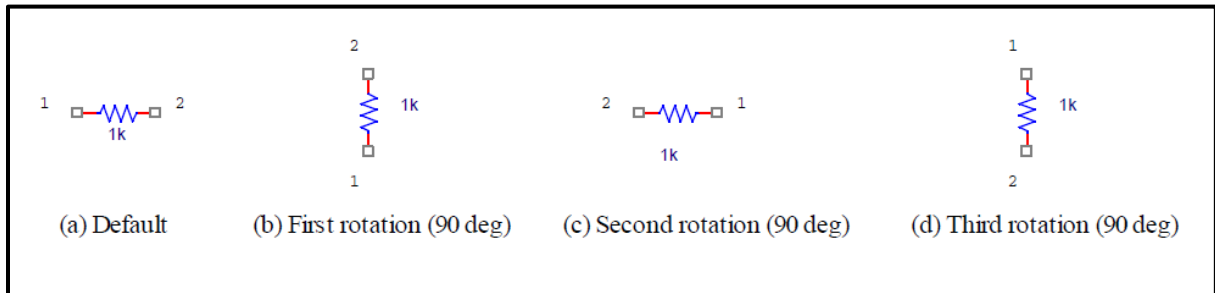

Figure.13

- Knowing about component layout is important when you are viewing your results in Probe to be discussed later.

➤ **Types of Analysis Performed by PSPICE**

PSPICE is capable of performing four main types of analysis: Bias Point, DC Sweep, AC Sweep/Noise, and Time Domain (transient).

- **Bias Point:**

The Bias Point analysis is the starting point for all analysis. In this mode, the simulator calculates the DC operating point of the circuit. **This is the type which was explained in the previous section.**

- **DC Sweep**

The DC Sweep analysis varies a circuit part e.g. voltage source, global parameter (resistor) over a specified range in an assigned number of increments in a linear or logarithmic fashion.

- **Time Domain (transient)**

The Time Domain (transient) analysis is probably the most popular analysis. In this mode, you can plot the various outputs as a function of time.

- **AC Sweep/Noise**

The AC Sweep/Noise analysis varies the operating frequency in a linear or logarithmic manner. It linearizes the circuit around the DC operating point and then calculates the network variables as functions of frequency.

➤ **Example on DC Sweep**

- To perform a DC sweep for the same circuit of the previous section, click on the “setup analysis” icon shown in figure 14.

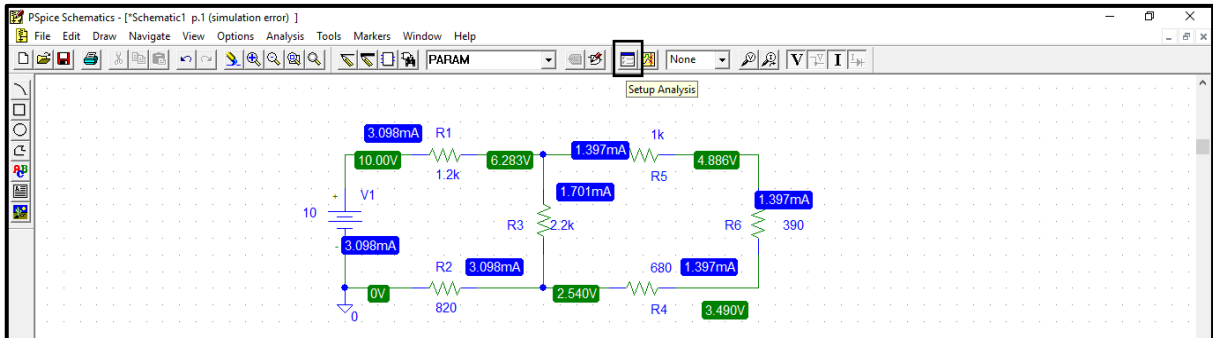

Figure.14

- The window shown in figure.15 will show up:

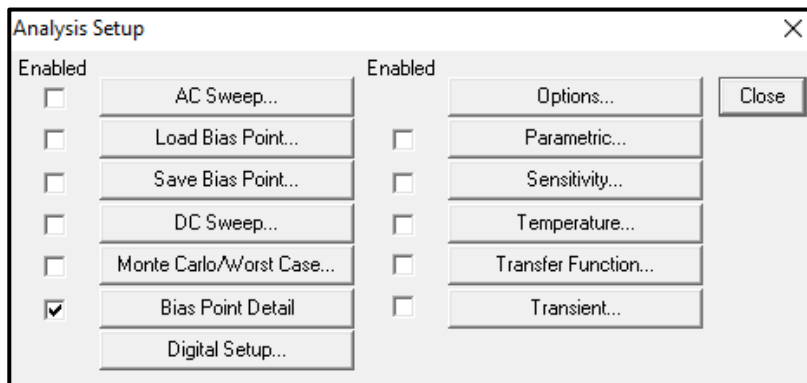

Figure.15

- Click on “DC sweep” and the window shown in figure 16 will show up, you have to fill the spaces indicated inside boxes in figure.16.

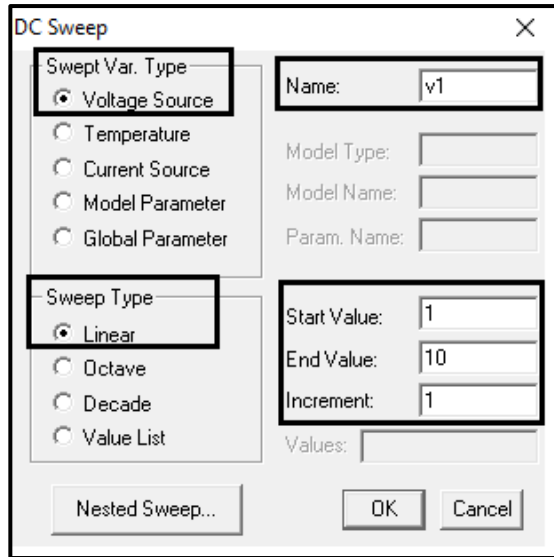

Figure.16

- Click on simulate, then the simulation output window will be as shown in figure.17:

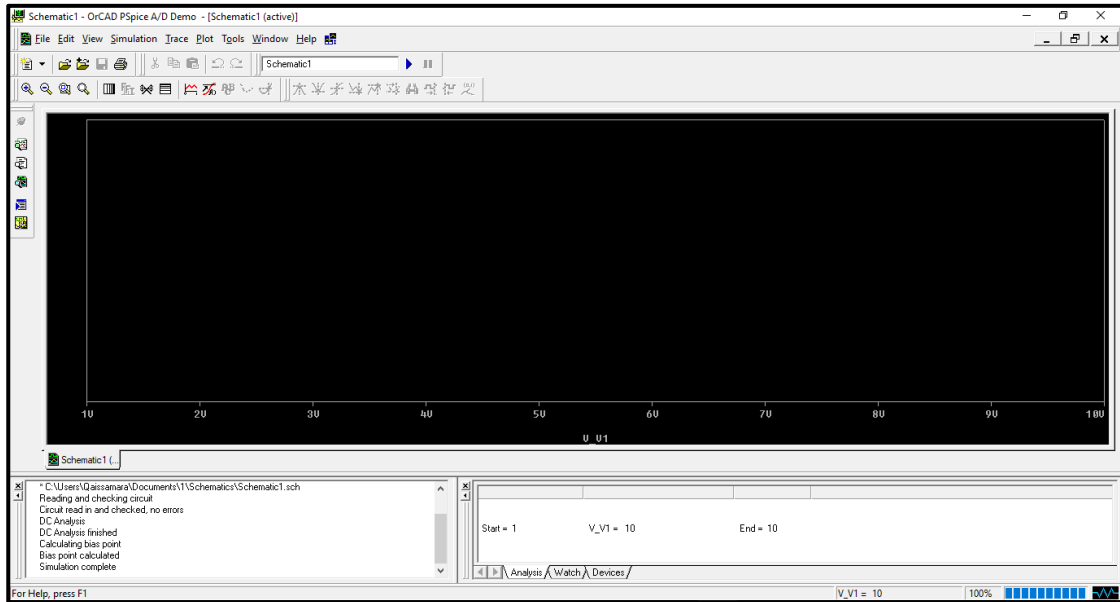

Figure.17

- The output now is displayed as curve rather than a point, to display the voltage across R6 for example click on “Voltage Marker” and place it where you want as shown in figure.18.

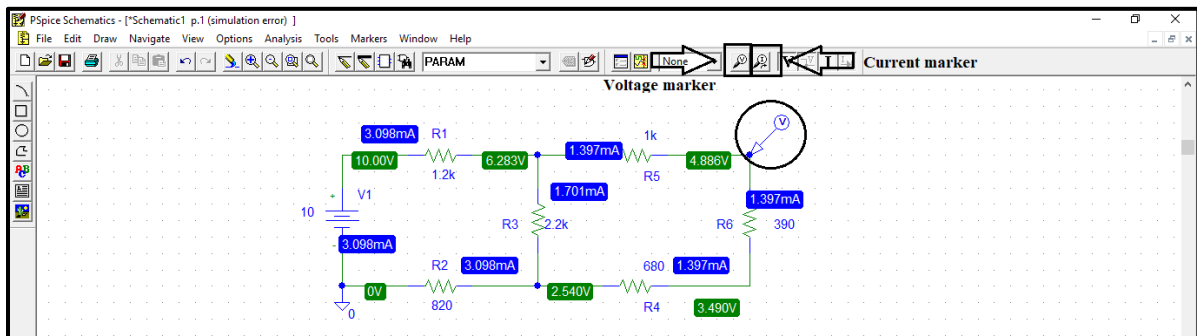

Figure.18

- When you place the marker, the output simulation window will be as shown in figure.19. this is a curve of the voltage at the node you placed the marker **with respect to ground**.

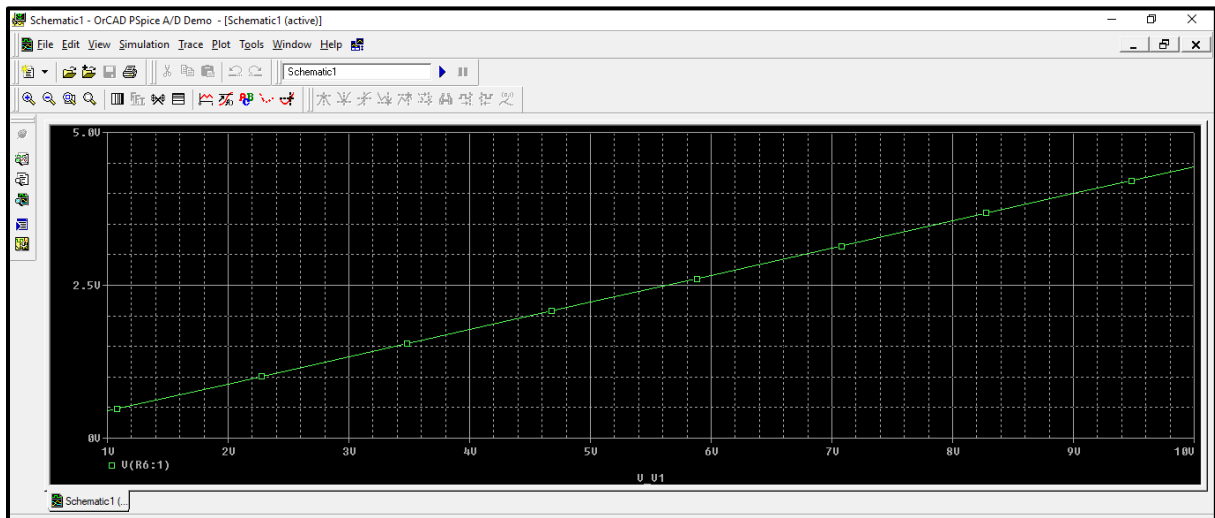

Figure.19

- If you want to display the voltage on R6 only, then go to schematic window, click on marker, and select “mark voltage differential” as shown in figure.20. (you will place two markers)

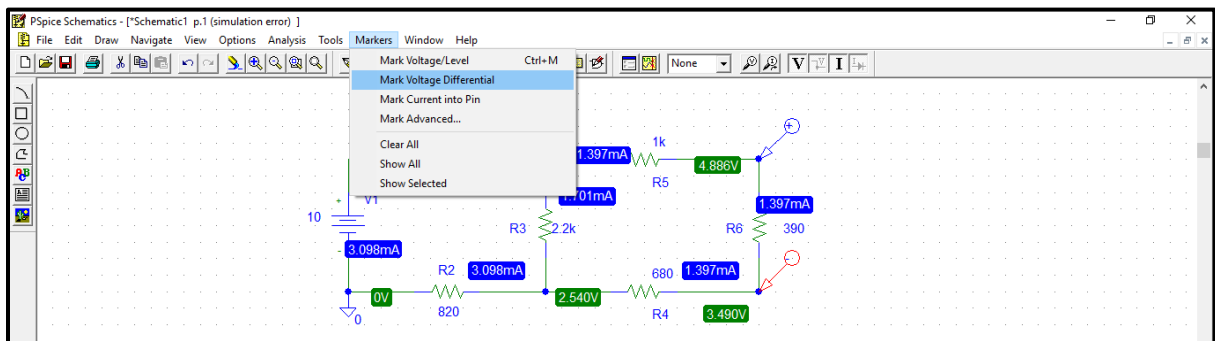

Figure.20

- The output now will be as shown in figure.21. **Note the difference on y-axis range!**

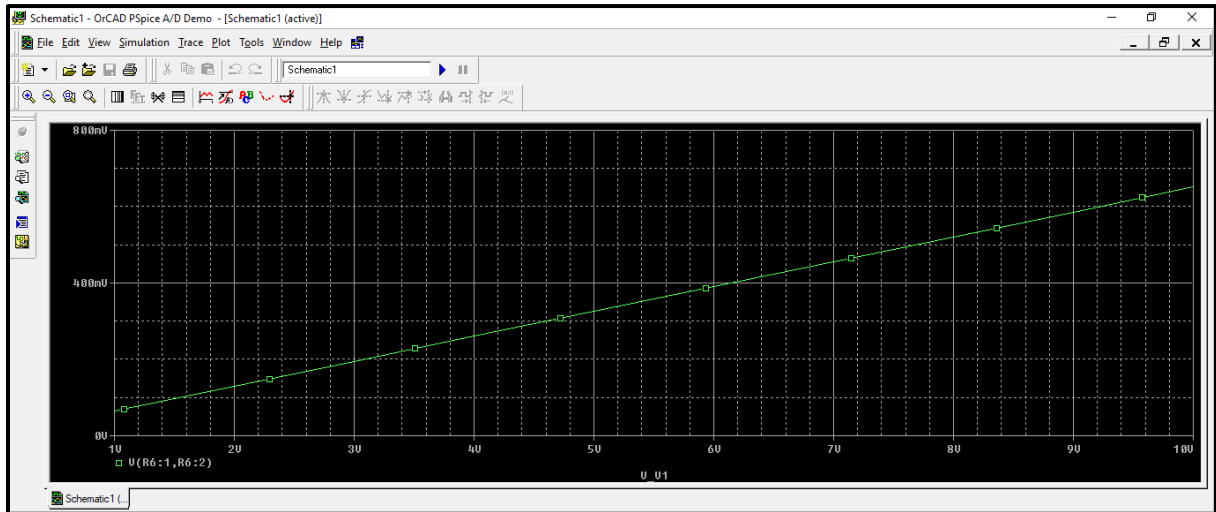

Figure.21

- You also can add curves, (traces) from simulation output window by clicking on traces and select add trace as shown in figure 22. You show current trace by clicking upon Current Maker (note that current marker must be placed on the terminals of a part to display current).

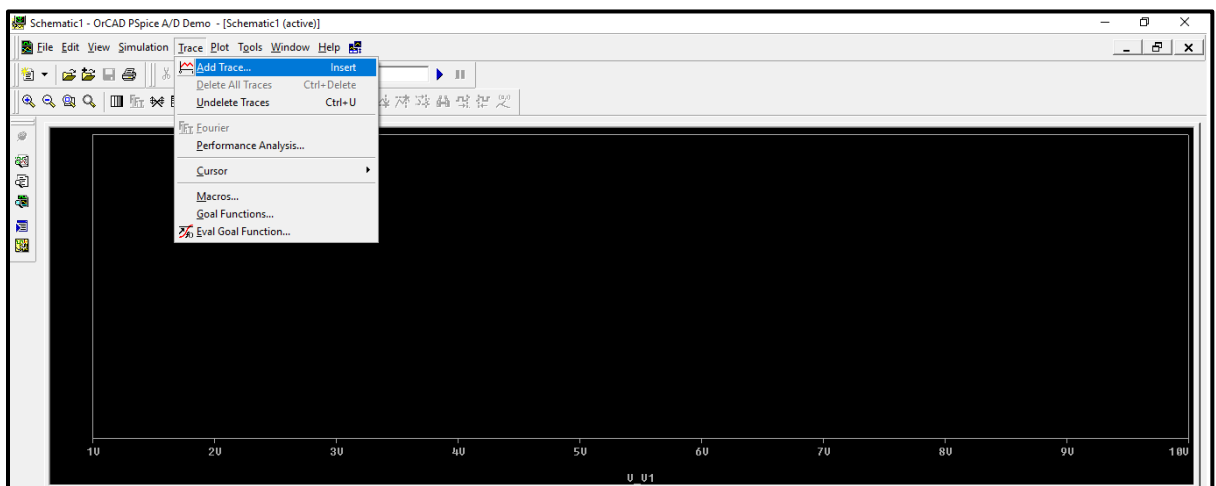

Figure.22

- Then the window shown in figure 23 will show up, in this window you will find a list of all variables in the circuit: (voltages and currents on all parts) to add a trace just click on it and it will show up in the field indicated in the box in figure.23.

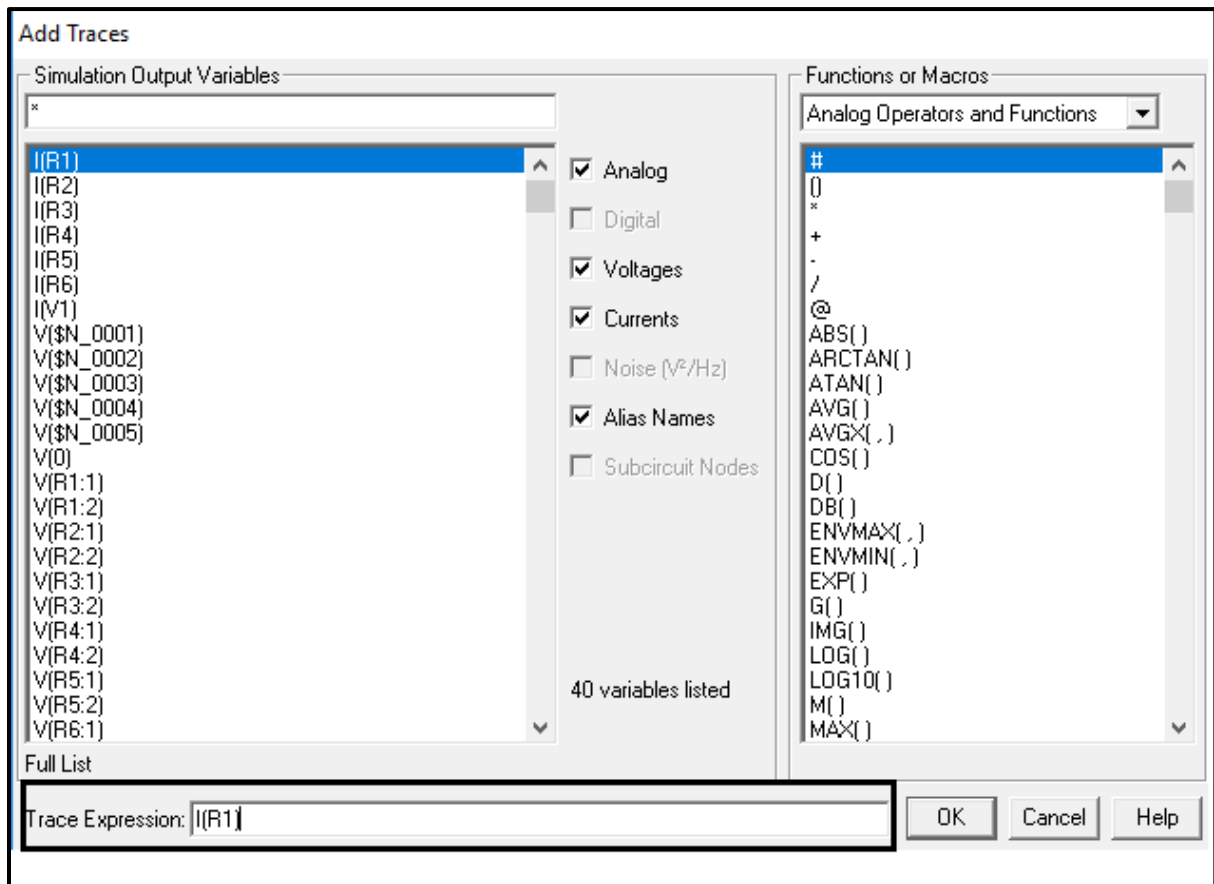

Figure.23

- When you finish selecting variables click on ok, and the trace you selected will be shown in simulation output window as shown in figure.24.

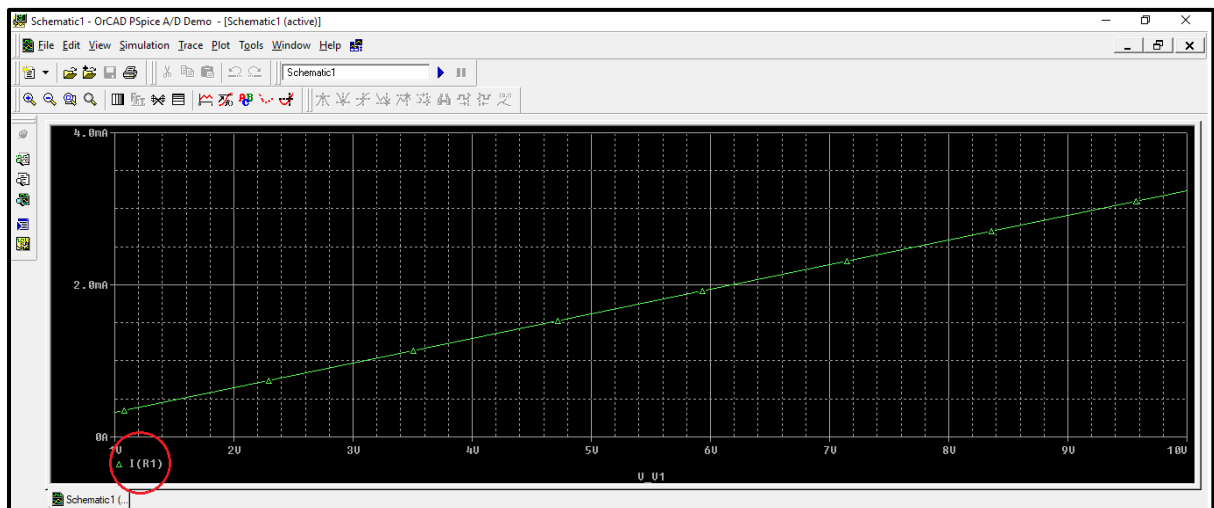

Figure.24

- In the “add trace window you can also add a trace that is a combination of more than one circuit variable e.g. to add a trace of the power dissipated in R6, note the equation inserted in figure 25.

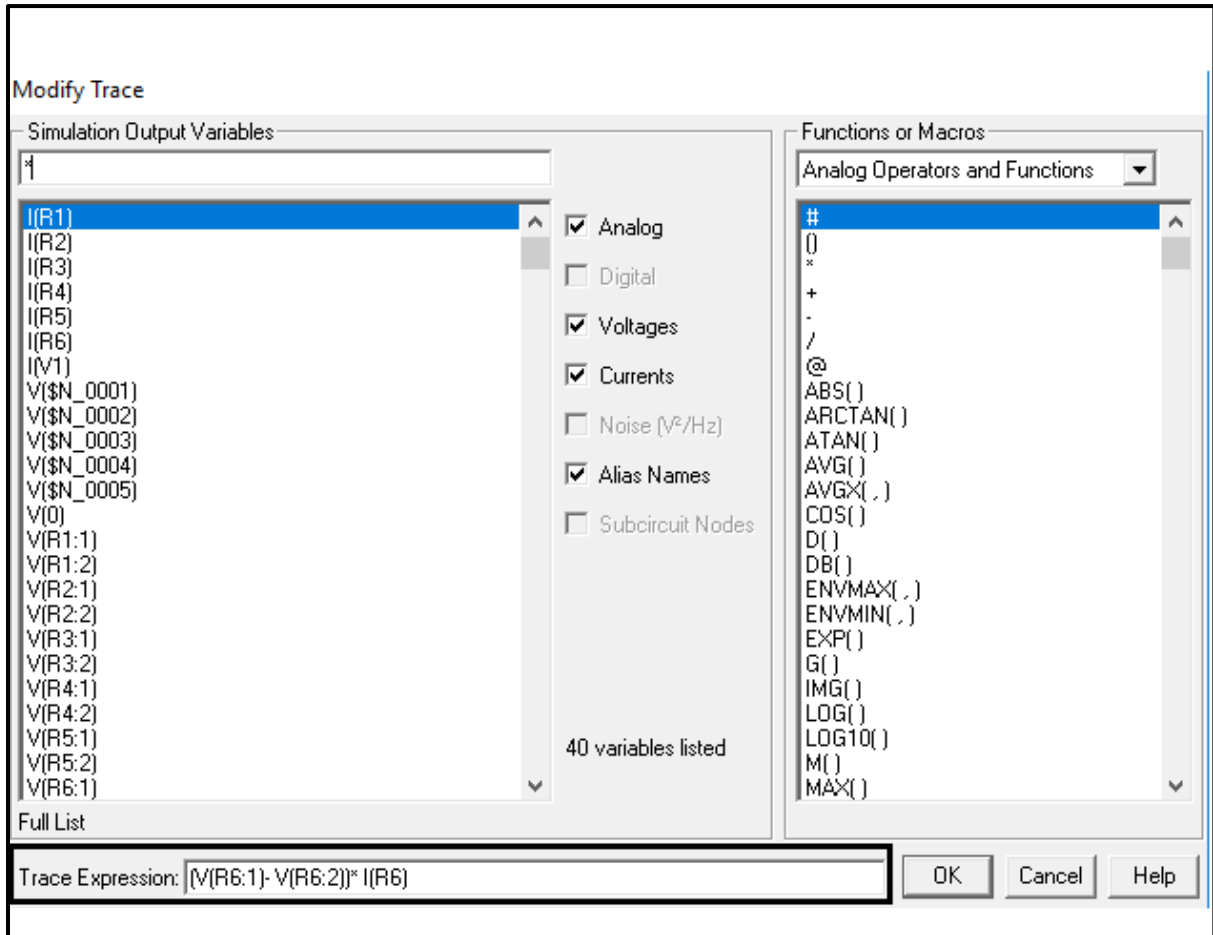

Figure.25

- The output is displayed in figure.26, note that the y-axis unit now is Watt.

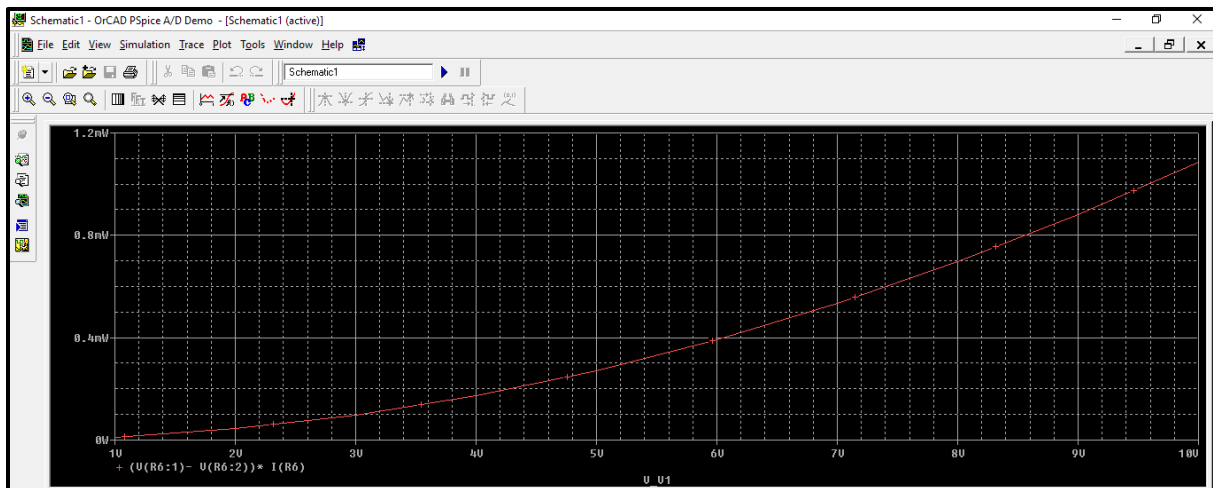

Figure.26

- To perform a DC sweep for a resistor in the same circuit, you need to add “param” part, go to “get new part” and search for “param”, as shown in figure.27.

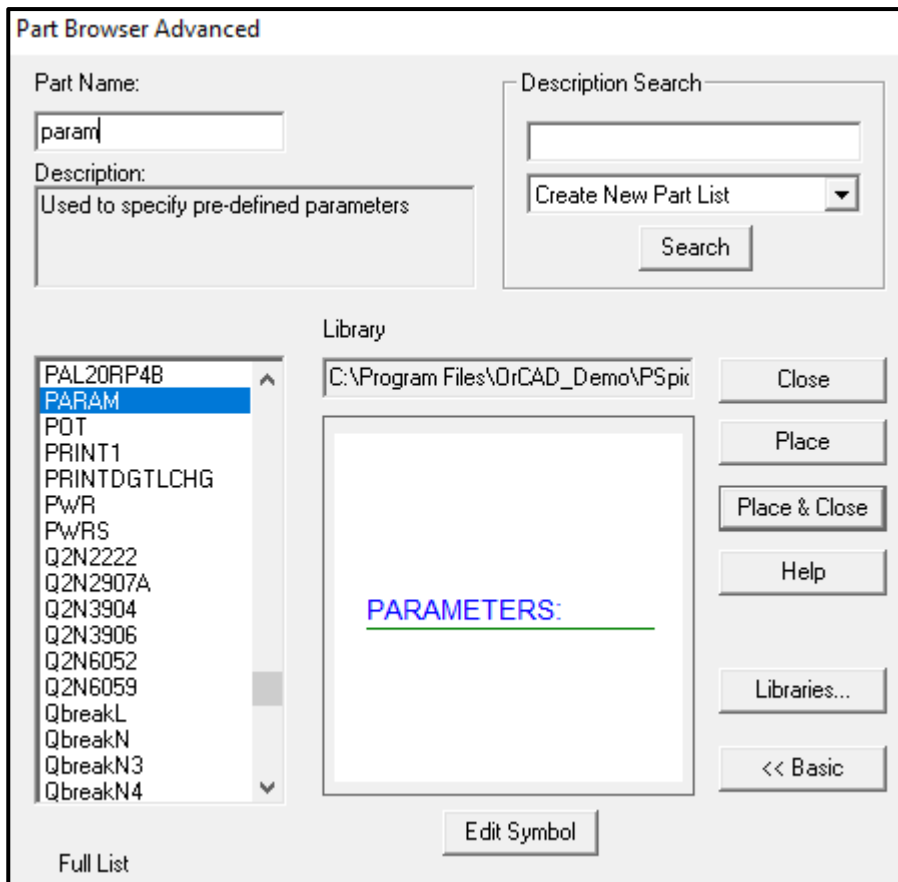

Figure.27

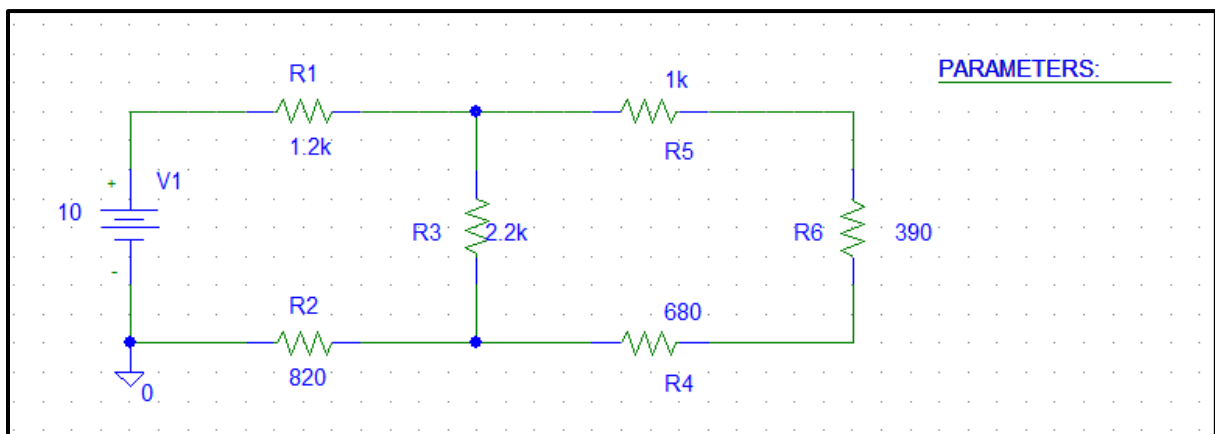

Figure.28

- Double click on “param”, and the window shown in figure.29 will show up, insert parameters as shown in figure.

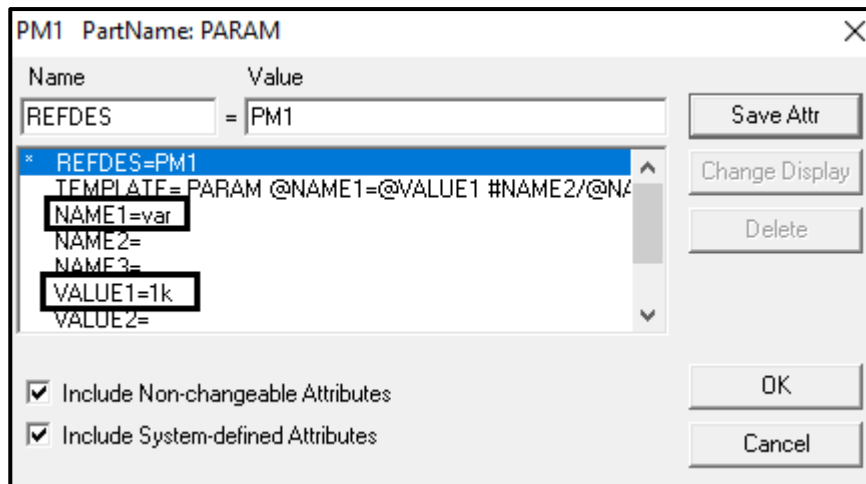

Figure.29

- Click on “setup analysis” and select DC sweep, fill in parameters as shown in figure 30.

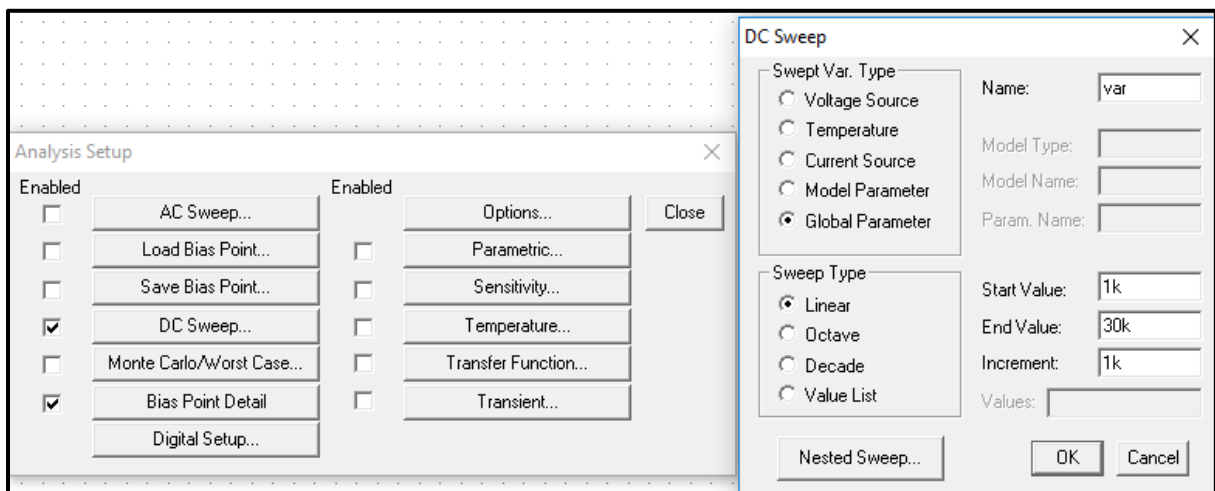

Figure.30

- Type the name of the global parameter inside curly brackets {}, as shown in figure 31.

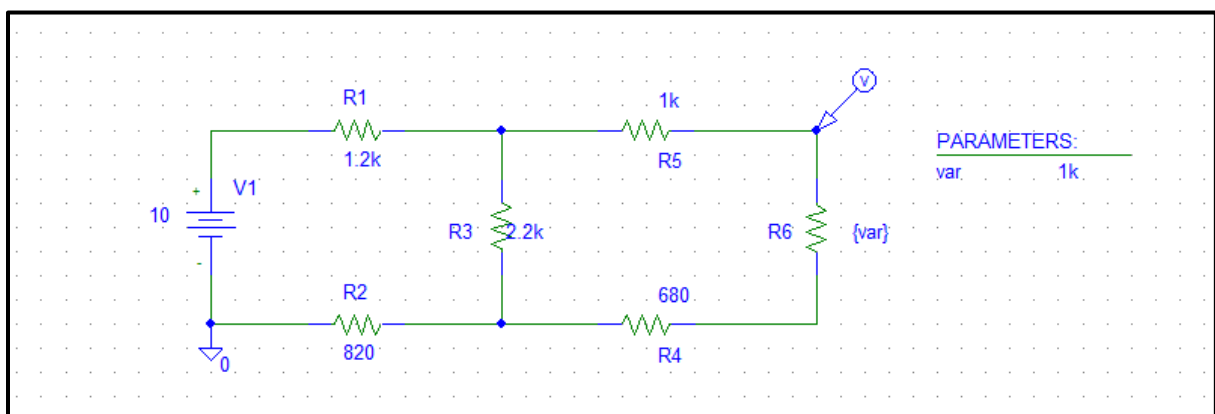

Figure.31

- Click simulate and check the output as shown in figure.32.

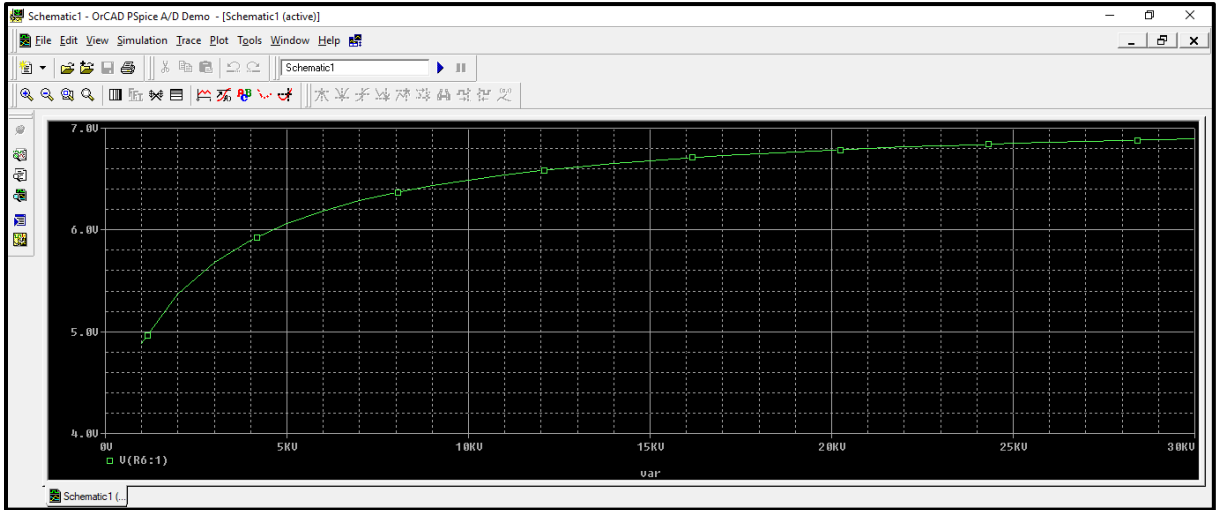

Figure.32

- To change trace properties such as width and color, right click on the trace and select properties as shown in figure.33.

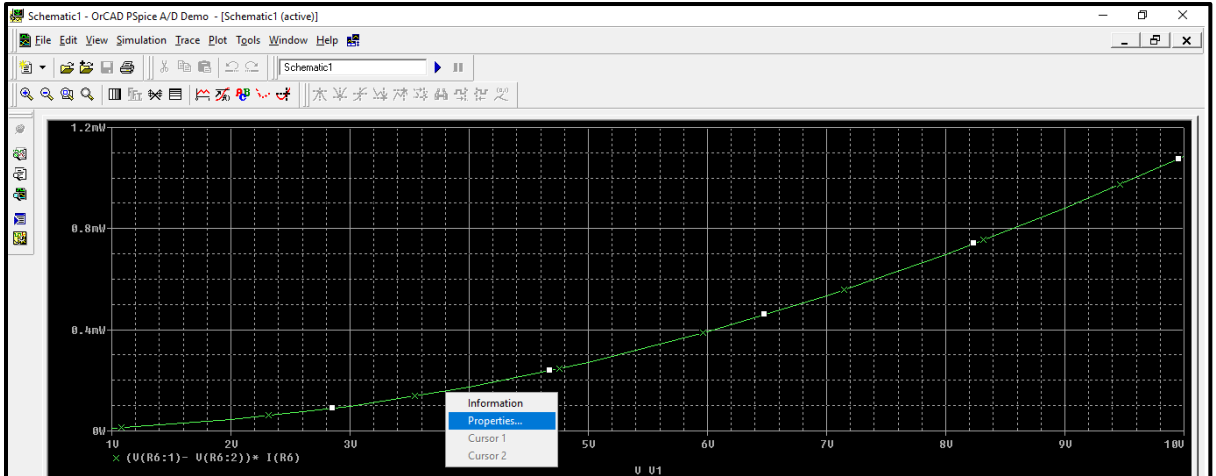

Figure.33

- The window shown in figure.34 will show up, you can change trace properties.

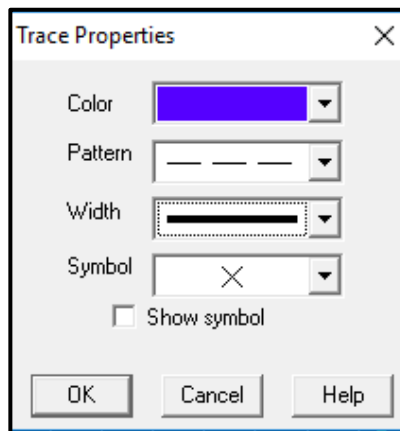

Figure.34

- After changing trace properties, the simulation output window will be shown in figure.35, **always make sure to increase the trace width in your prelab.**

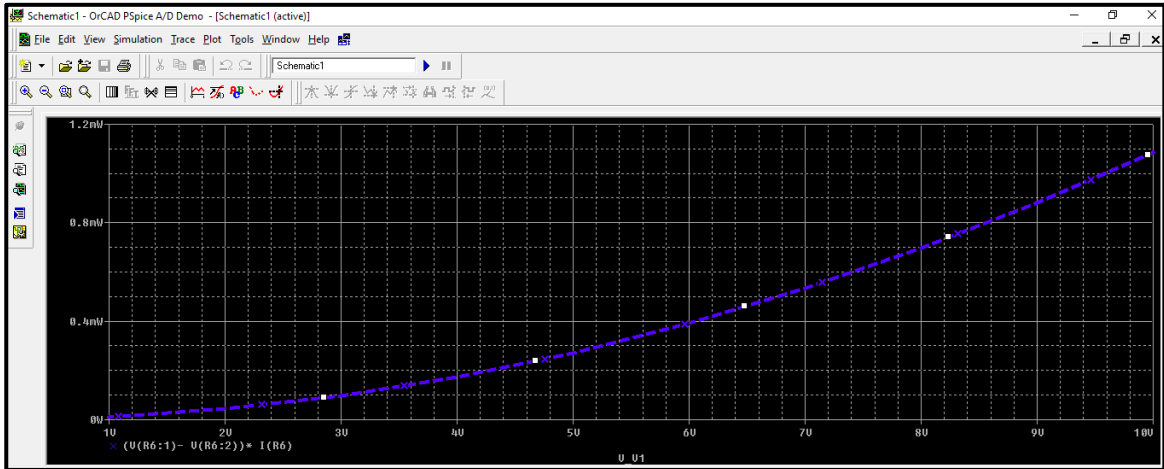

Figure.35

- **To copy the output curve to a word document,** go to the simulation output window and click on window then select “copy to clipboard”, then select ok as shown in figure.36.

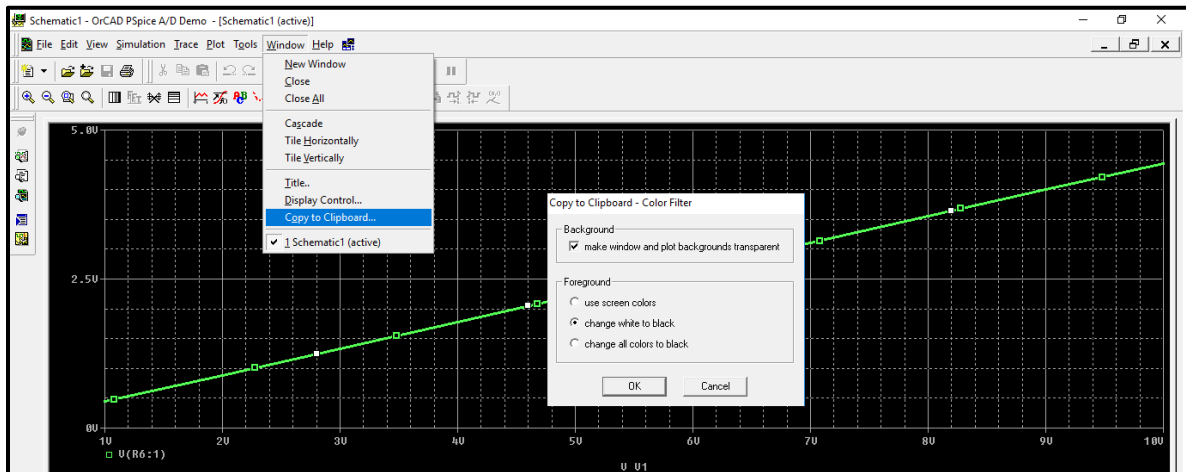
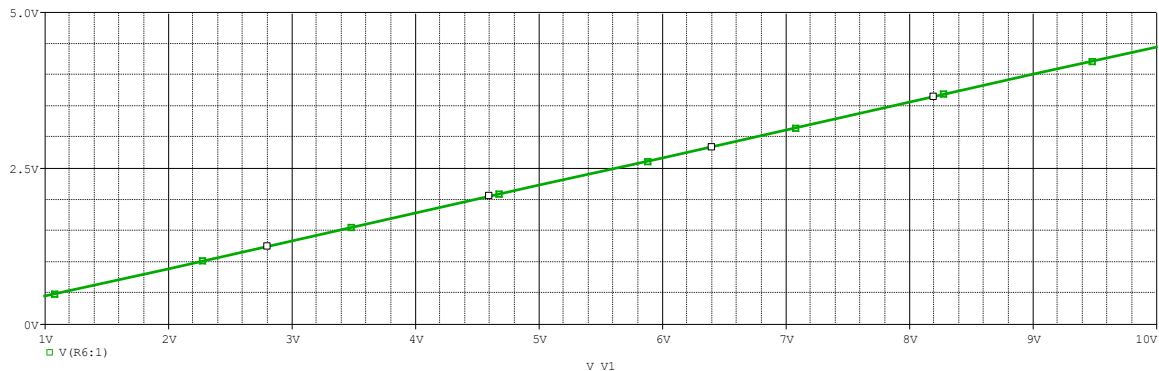

Figure.36

- Then click “paste” or “ctrl+v” inside word document and the output curve is copied a shown.



➤ Example on Transient analysis

- The circuit shown in figure.37 contains a square wave source which is a function of time, so we will use transient analysis.

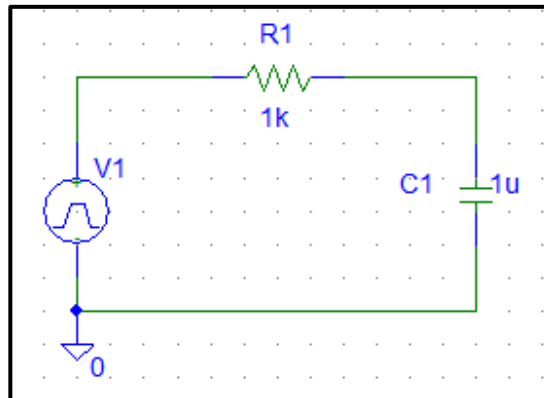

Figure.37

- The source name is “vpulse” and can be found on the components list as shown in figure.38.

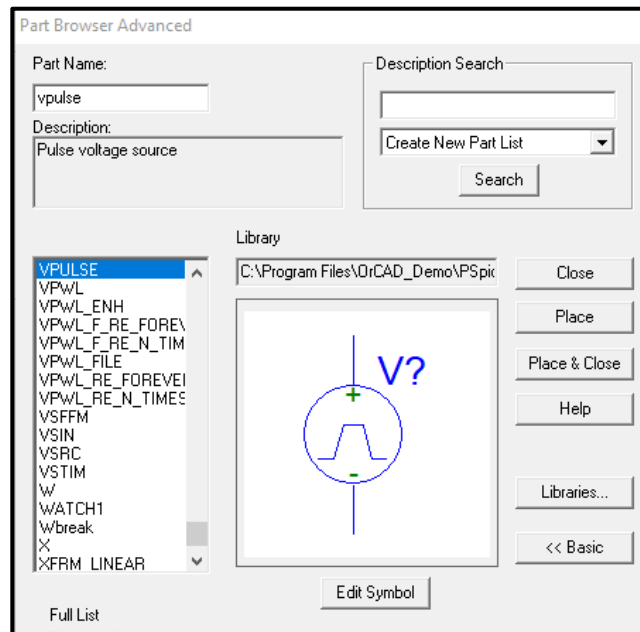

Figure.38

- Double click on the source to insert its parameters, the window in figure.39 will show up.

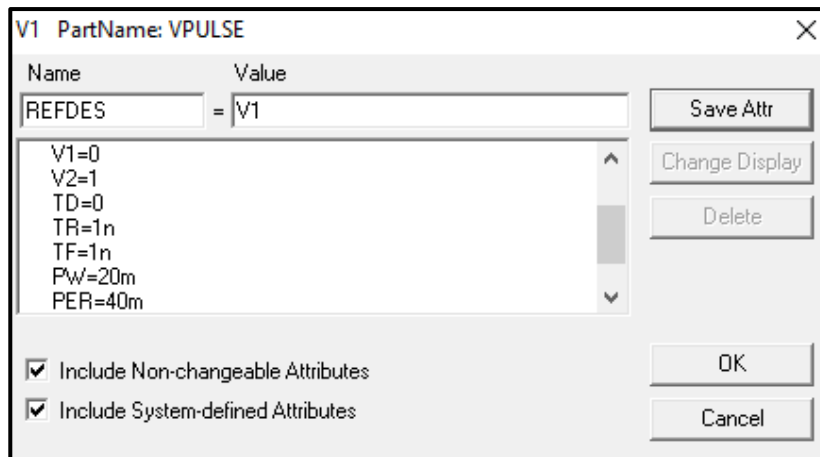

Figure.39

- Table.3 provides the details of this parameters.

Table.3

Parameter	Description	Value
V1	Lowest value	Usually 0
V2	Highest value	Depending on the question e.g. 1
TD	Delay Time	Usually 0
TR	Rise Time	1n
TF	Fall Time	1n
PW	Pulse Width	(1/ 2xFrequency) e.g. 20m
PER	Period	(1/ Frequency) e.g. 40m

- To perform a transient analysis for the circuit of figure.37, click on the “setup analysis” icon and select “Transient”, the window in figure.40 will show up.
- There are **two important parameters** that must be determined carefully in transient analysis so you can picture the output properly, these are: **Final time, and step ceiling.**
- **Final time** is the time till which you want to see the output signal, it is usually selected three times the period of the source.
- **Step ceiling** controls the accuracy (**smoothness**) of the output plots, it is usually obtained by dividing the final time on 10^4 .

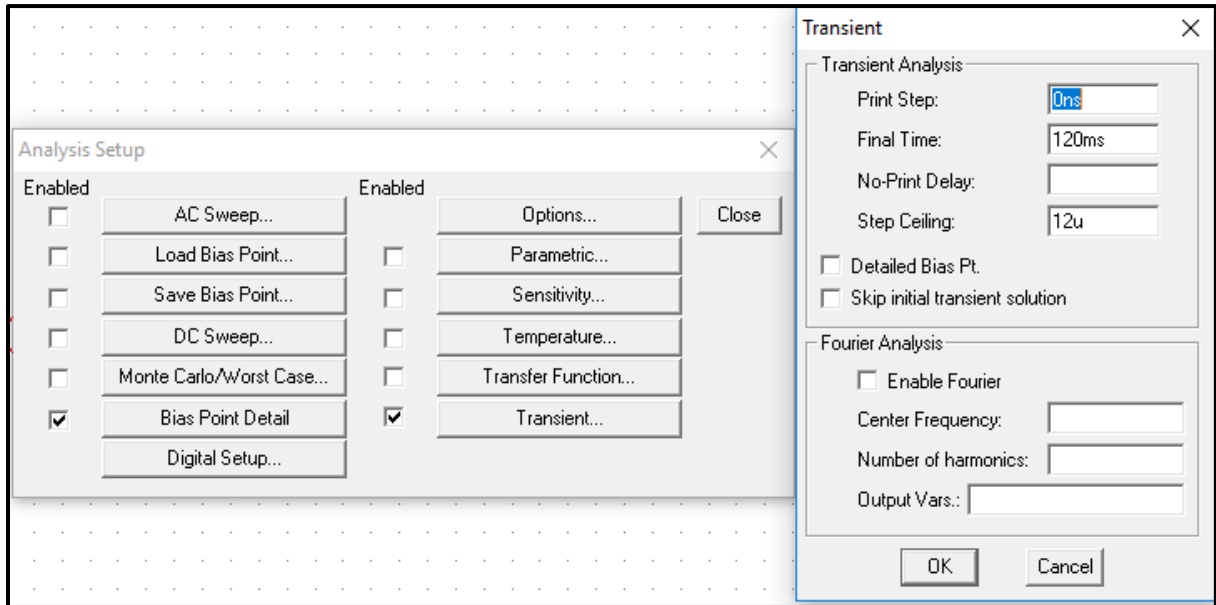

Figure.40

- The output is now displayed in figure.41.

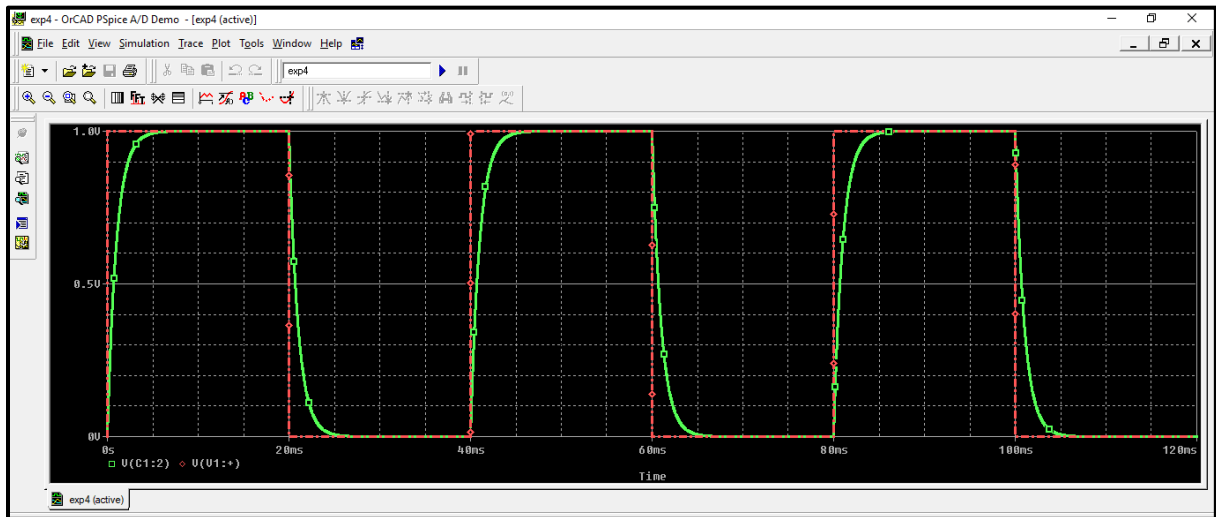

Figure.41

- Cursors are often used to determine certain points on traces to use cursors click on “toggle cursors” icon shown in figure.42.
- There are two cursors in PSPICE (a1), and (a2), you can move between them by clicking the right and the left buttons of the mouse.
- Each cursor has a reading of x-axis and a reading of y-axis, look at figure.42.

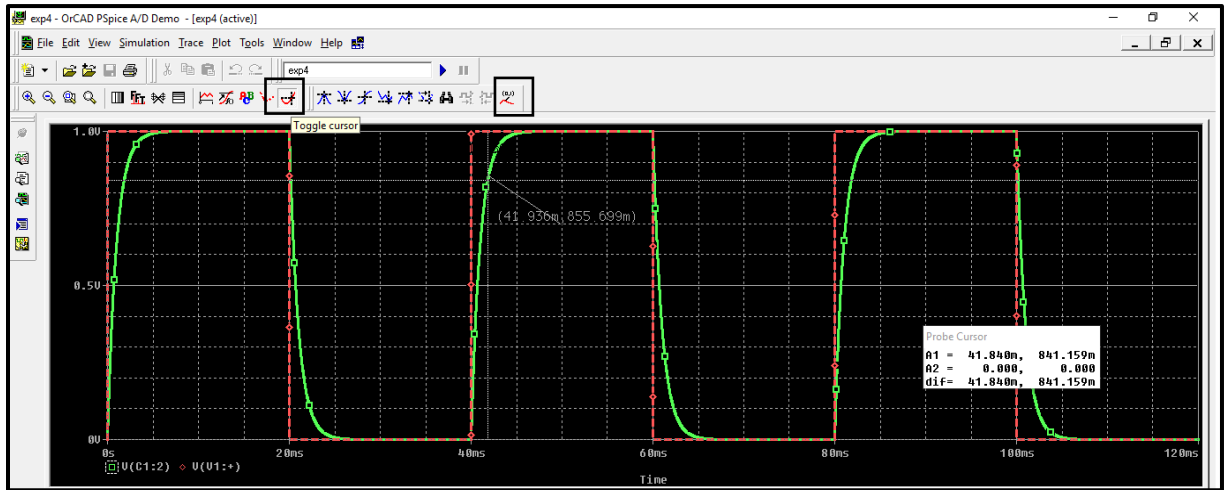

Figure.42

- Another example on transient analysis, sinusoidal voltage source (vsin).

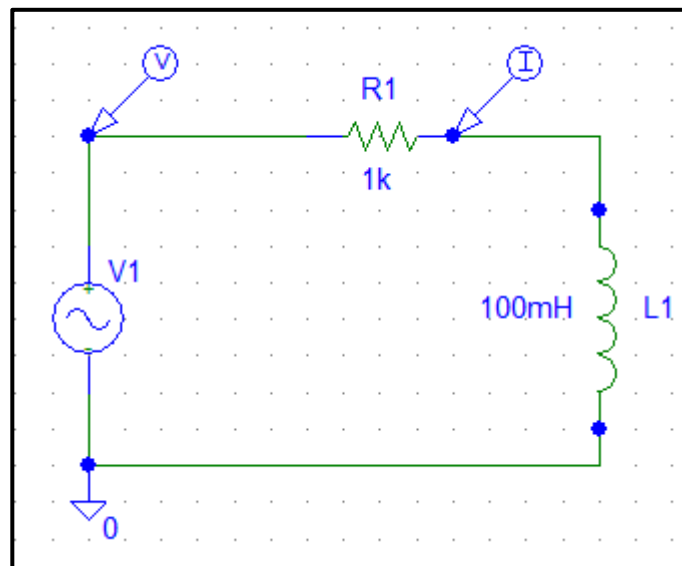

Figure.43

- Source settings.

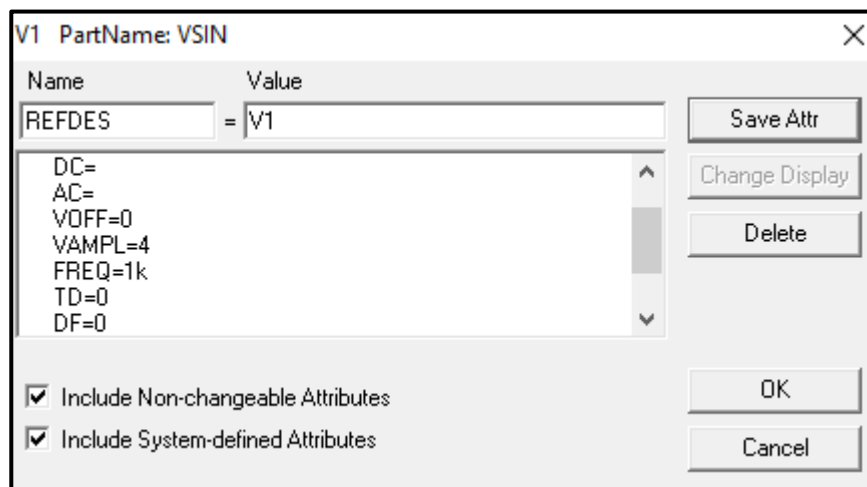

Figure.44

- In the simulation output window, we are viewing the current and voltage, but the voltage is in the range of (-4 to 4) and the current is in the range of (-4m to 4m) so we need **to add a separate y-axis to the output window.**
- Click on “plot”, then select “add y-axis”, note that you have different y-axes as shown in figure.45, you can move between axes by clicking on the axis you want to add a trace to.

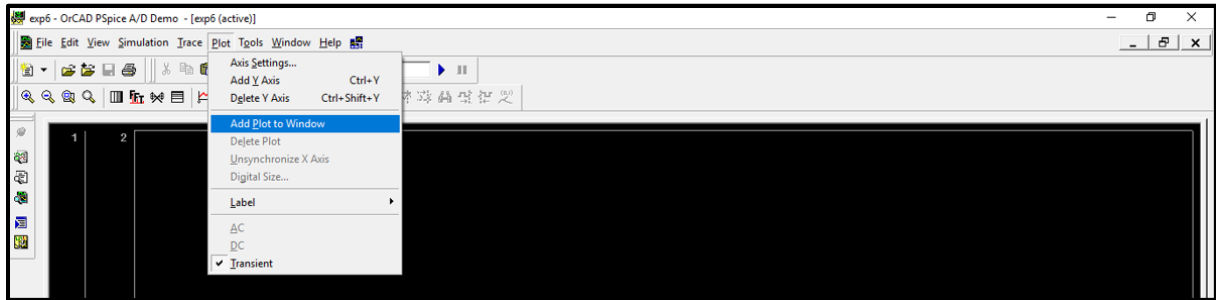

Figure.45

- Voltage and current traces are shown in figure.46, each trace is on a different y-axis range.

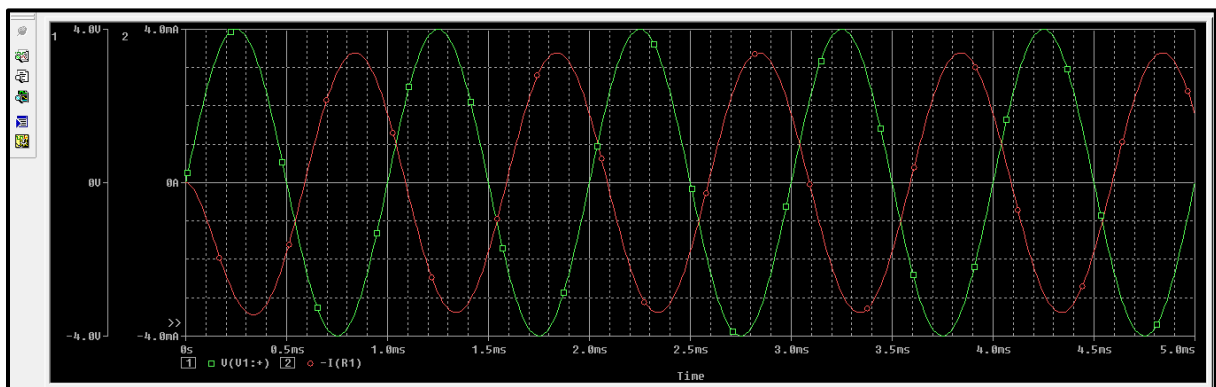

Figure.46

➤ Example on AC sweep analysis

- The circuit shown in figure.47 contains an (vac) source which is used for AC sweep analysis.
- Double click on the ac source to insert setting: only insert voltage magnitude to 1.

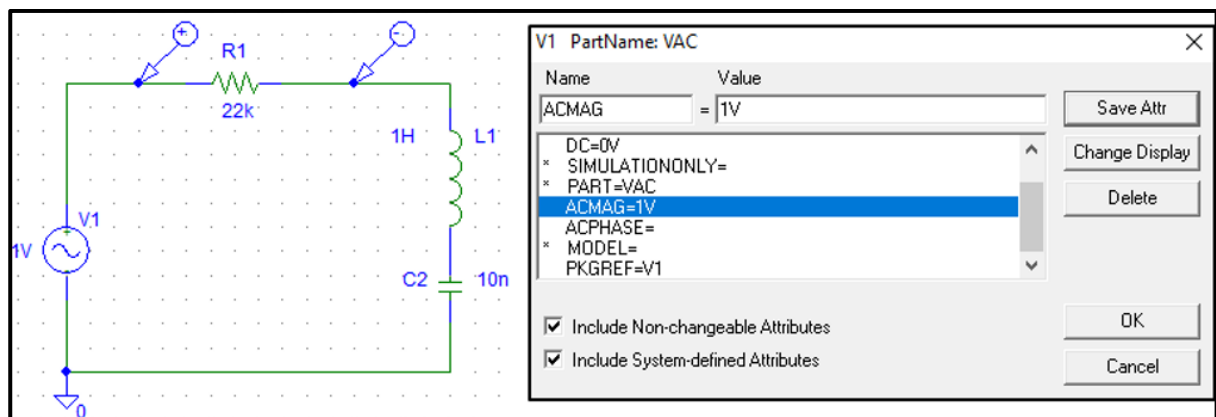

Figure.47

- Setup analysis setting: usually select “AC sweep type” to decade.

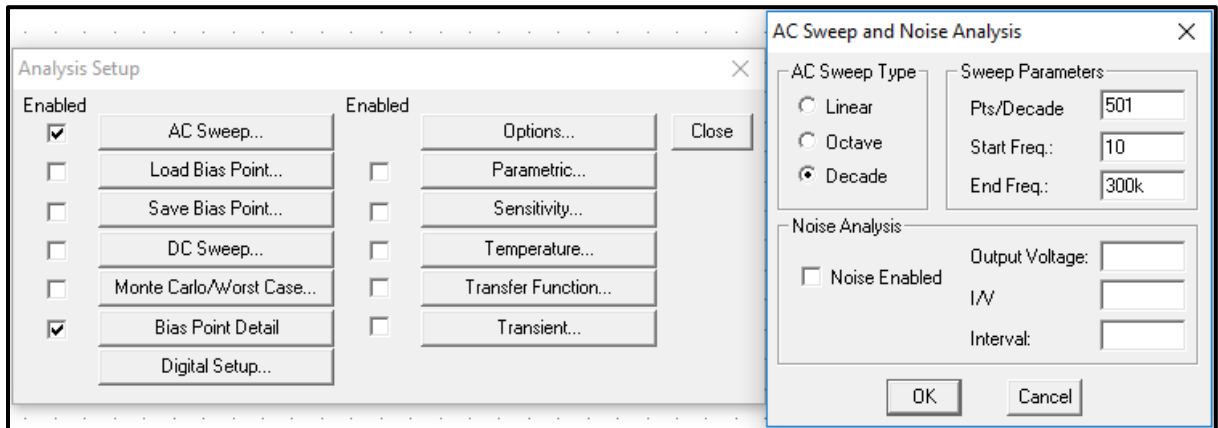

Figure.48

- Output window:

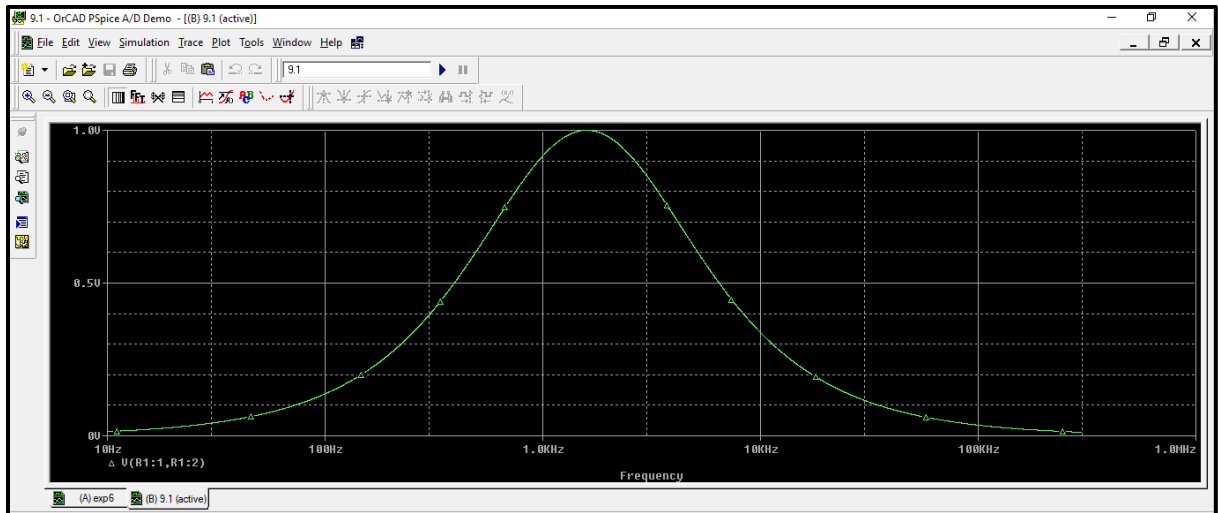

Figure.49

- To get the magnitude in dB:

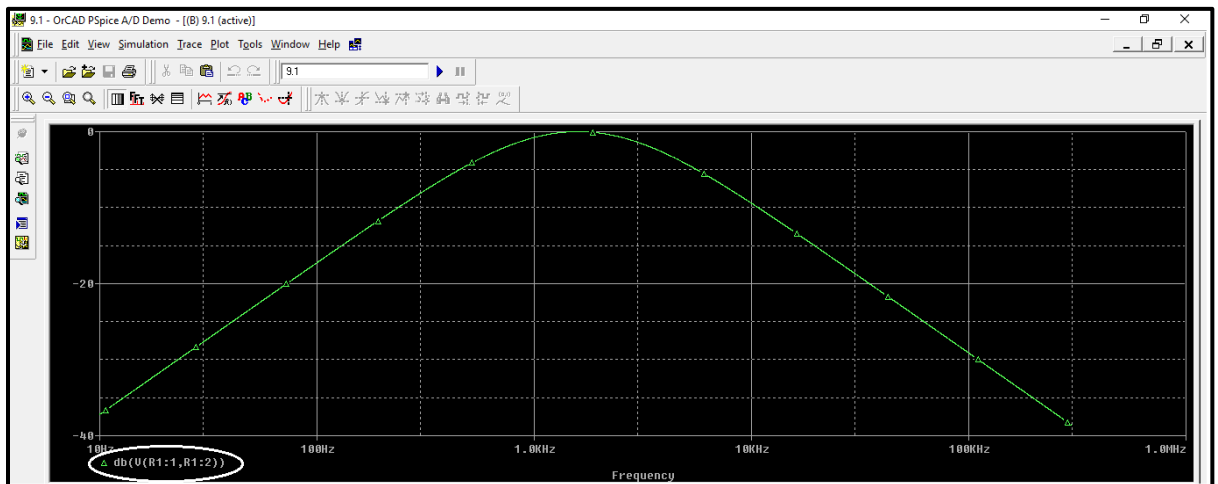

Figure.50

- To get the phase:

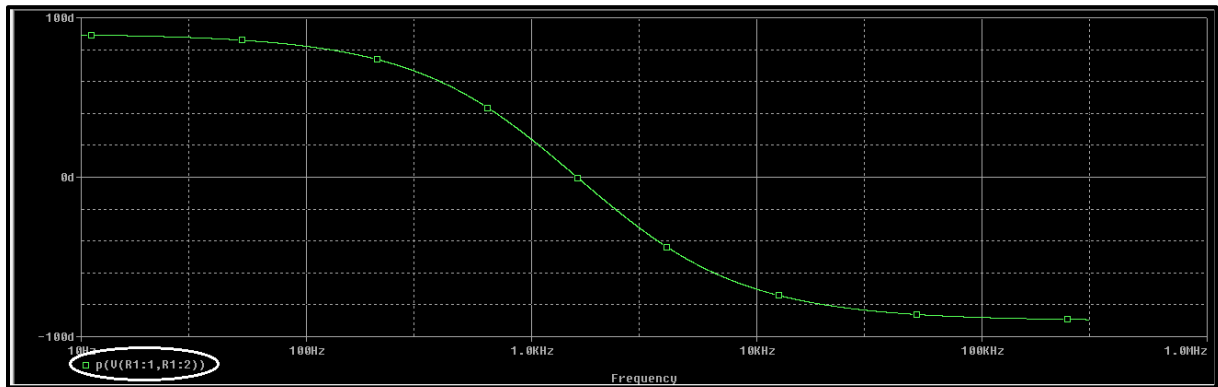

Figure.51

- Another example:

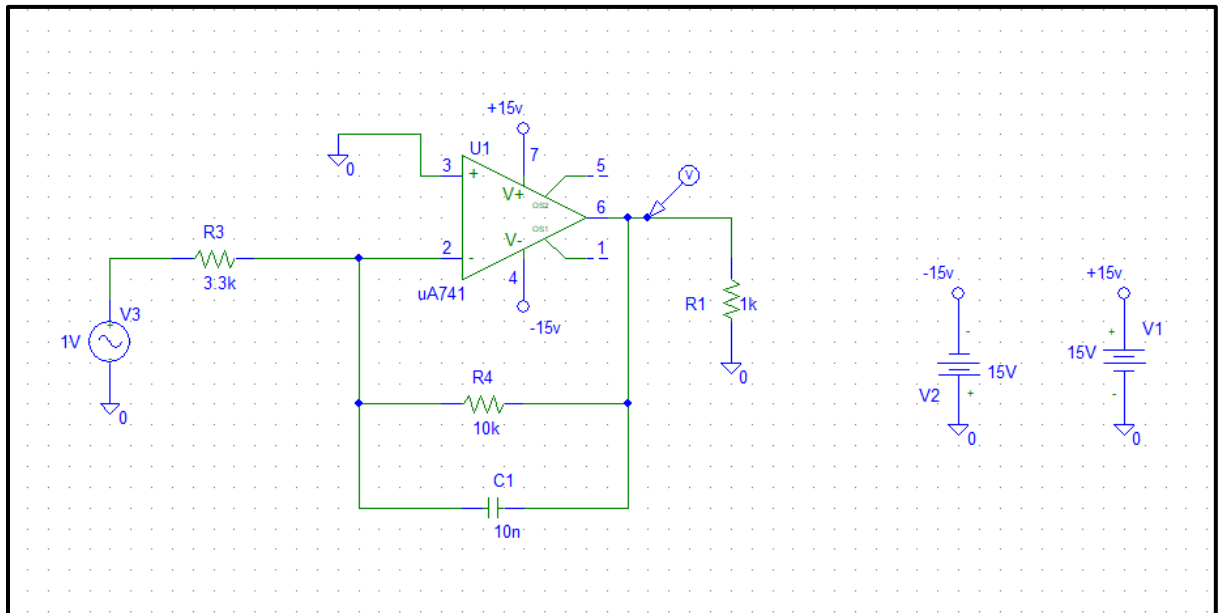

Figure.52

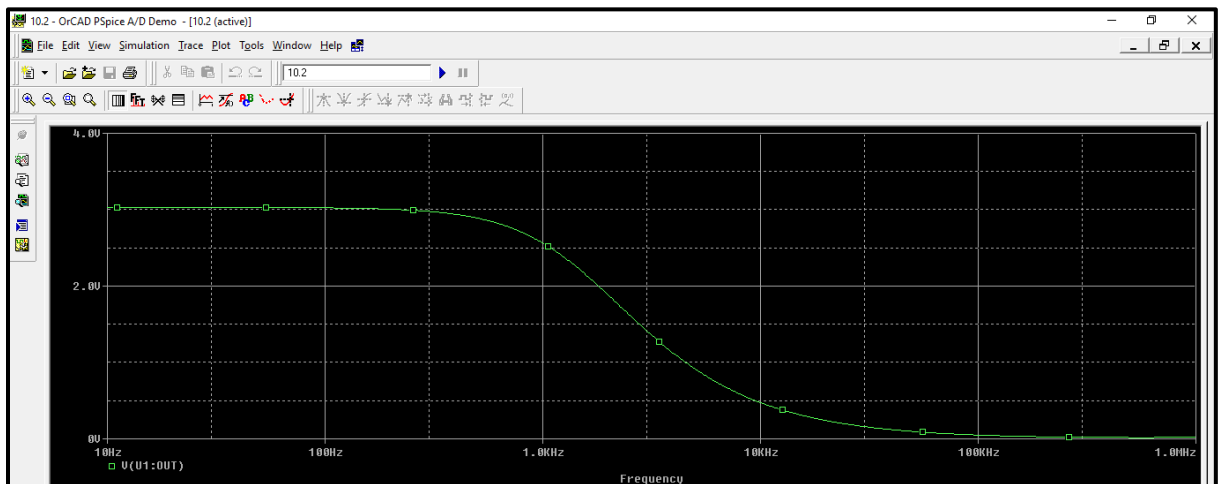

Figure.53

➤ **Report writing guidelines**

An experiment report is an important tool to communicate the experiment results and findings to others, it should be organized and written in clear a way. **Reports should be original and contain the basic required elements detailed below, copying from any source will result in a zero grade and proper academic punishment.**

The report must contain the following sections:

1. Cover page

Cover page must contain: course number and name, section number, lab experiment name and number, author name, date performed, lab partner(s) name(s), and the instructor's name.

2. Table of contents:

A list sections headings and page numbers.

3. Abstract

This section provides a brief summary explaining the aim of the experiment, and the methods used. Use your own words, do not copy objectives from manual.

4. Theory

This section should include any relevant theory along with mathematical formulas. The following should be considered when writing the theory section:

- Avoid copying from lab manual, summarize the theory in your own words.
- If you used information from any resources, state them in references.
- Explain symbols in the mathematical formulas, and use graphical representation of formulas (curves) where applicable.

5. Procedure

This section describes in detail the way the experiment was conducted. This is very important so that anyone who reads it should be able to re-produce the experiment and its results. In this section, what was measured and how it was measured should be provided.

6. Data, Calculations, and Analysis of results:

- Your report must include a section for data aside from the sheet you used to record data in the lab, which must be attached at the end of your report. The data should be

recorded in clear and readable fashion, be provided in tables where possible, and should have units.

- Calculations should be performed to get the required quantities from measured ones, you must show **a detailed sample calculation showing any equations used**.
- You have to discuss all results comparing with what was theoretically expected from prelab exercise and explaining any differences. Discuss results **qualitatively** i.e. no need to state numeric results for each result as the experiments usually contains measurements of many quantities, it is enough to state the general behavior of results. The discussion should contain answers to the following questions:
 - Is the result acceptable?
 - What is the behavior of graphs/plots?
 - What are the possible sources of error?
- Any questions in the procedure section must be answered in this section when discussing results.

7. Conclusions

Restate the main objectives and how or to what degree they were achieved. What principles were validated by the experiment? Were there any major experimental complications? How the result can be improved in the future if the experiment is repeated (optional)?

8. References:

List any references you used in writing your report, examples on IEEE references formatting are given below:

example of textbook:

[1] J.W. Nilsson and S.A. Riedel, Electric Circuits. Reading, MA: Addison-Wesley, 5th ed., 1996, pp. 111-113.

example of Internet web page:

[2] Approximate material properties in isotropic materials. Milpitas, CA: Specialty Engineering Associates, Inc. web site: www.ultrasonic.com, downloaded Aug. 20, 2001.

General Format Guidelines

1. Use bold font with size (14 point) for titles (Times Roman or Arial), and 12 points elsewhere. Also, use 1.5 line spacing, and justify all paragraphs.
2. Place page numbers on all pages, bottom (though title page is page 1, don't display the number 1 on the title page).

- Equations are centered and the equation numbers are right justified. The equation number is placed in (). See example.

$$F(s) = \int_{-\infty}^{\infty} e^{-st} f(t) dt \quad (1)$$

- Center all tables and include a **heading and caption with the appropriate table number above each table**. For example, “Table 1: Voltage measurements for Part 3”
- Figures must be centered, and the **figure number and caption are centered beneath** the figure. For example, “Figure 1: Circuit schematic of Butterworth filter”.
- All graphs must be done with a computer (e.g. Microsoft Excel or even Matlab).
- All graphs require labels and units on the axes, and require a legend for more than one set of y-axis data.
- Include a leading zero when a number’s magnitude is less than 1 (use 0.83 instead of writing .83). Include a space between any number and an associated unit (i.e., 3.4 mA, not 3.4mA).
- Use your word processor for Greek symbols for common engineering quantities as β , π , ϕ , ω , and Ω . Also use Microsoft word to make any necessary superscripts and subscripts. (Use $V = 10R^2$ instead of $V = 10R^{\wedge}2$).
- Verb Tense:
 - Use past tense when describing a procedure that was implemented in order to produce your results. For example, “After constructing the circuit of Fig. 1, power was applied.”
 - Use present tense when analyzing the results and making conclusions. For example, “The data shows that the efficiency of the process is 92%.” Also, when making reference to a figure or data within the report, use present tense. For example, “The test setup is shown in Fig. 1.”

Report Grading Guidelines

The laboratory report grade will depend on the following:

- Is the report written well and in good English?
- Does the theory contain the necessary illustrative figures? Are these figures meaningful and clear?
- Do data and calculated quantities have correct units?
- Are calculations made correctly?
- Does the report contain all information to reproduce the experiment?
- Is the result correct and consistent with what is expected?

- Are the graphs complete, correct and properly labeled (title, axis labels)?
- Are all elements of the report included?
- Is the report submitted on time?

A sample report will be sent to you through Ritaj, where you will see all the guidelines are considered in writing that report, always refer to this sample report and to the guidelines when writing your report.

Experiment 2

Introduction to measurements and lab devices

➤ **Objectives:**

1. In this experiment, we shall study how to use the digital multi-meter, power supply, function wave generator, and the oscilloscope.
2. To make some measurements in the lab.
3. Measuring Phase between two signals.

➤ **Equipment Required:**

1. Board, resistors, capacitors and wires.
2. Digital Multi-meter GDM-8135.
3. Oscilloscope TDS 2002B.
4. Power Supply Unit TK286 [0-20V] Variable DC.
5. Function Wave Generator GFG-8215a.

➤ **Introduction:**

- **Board:**

Used to build circuits on it. Each adjacent four holes marked with a white line forms one node (short circuit), circuit elements are connected between nodes, the board is shown in Figure 2.1.

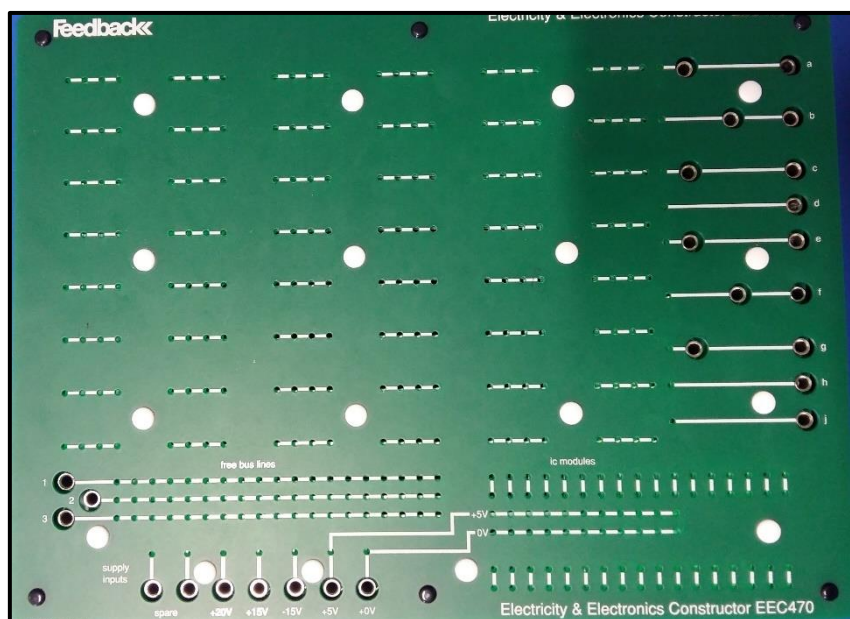

Figure 2.1: board.

- **Power Supply Unit:**

Power supply unit provide AC and DC voltage output. We will use the Power Supply Unit (Feedbak 92-445) shown in Figure 2.2.

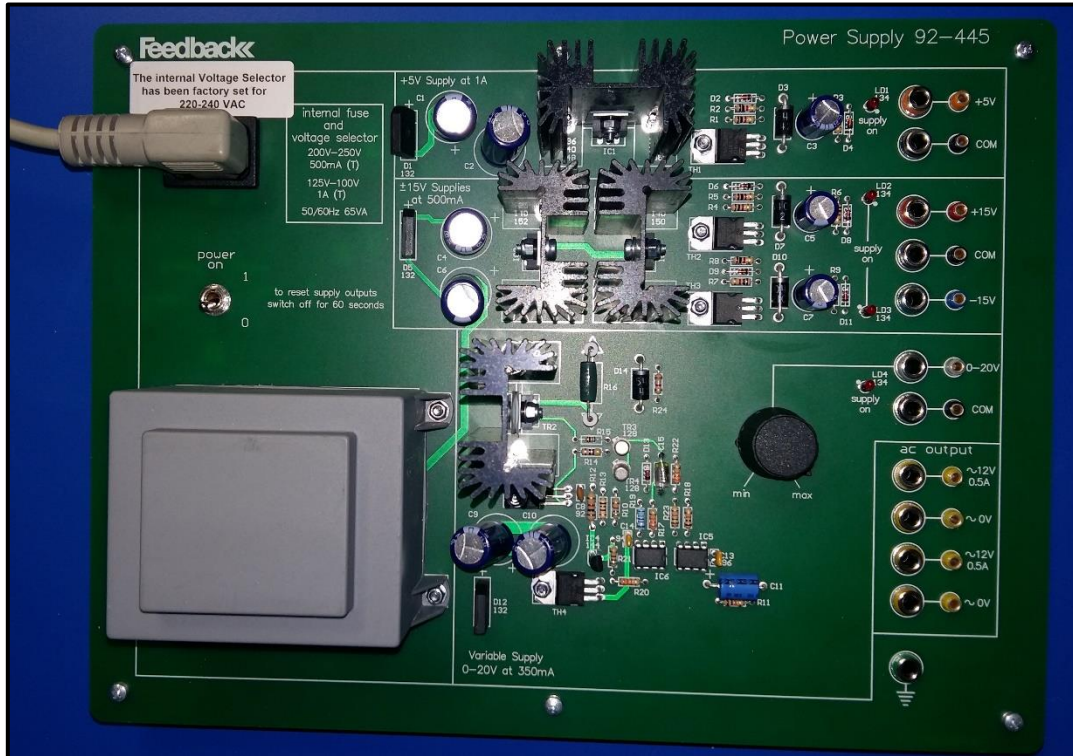

Figure 2.2: Power supply unit.

- **Digital Multimeter:**

Digital Multimeters are used to measure resistance, voltage and current. This makes the multimeter one of the most important instruments. We use the GDM-8135 in the lab as shown in Figure 2.3. This is typical of such instruments. The power switch is located on the lower right of the front panel, with green color.



Figure 2.3: Digital Multimeter GDM-8135, connected as ammeter.

- The multimeter has three buttons indicated above that determine which type of measurement is being made. For example, if you want to measure resistance, you have to select the resistance mode button. Likewise, current and voltage modes can easily be set.
- Next, you need to attach cables to the multimeter ports. You may use cable with a connector as shown in Figure 2.4.



Figure 2.4: Cable with a connector.

- A black cable inserted in the black port called 'common' or COM. Another red cable is inserted in one of the three red ports depending on the quantity to be measured.
- **To measure voltage or resistance**, the red cable is inserted in the upper red port which is marked (V- Ω).



- **To measure current**, the red cable is inserted in one of the two lower red ports which are marked 2A max, 20A max. The First port is fused and can measure currents up to 20 A. The second port is used to measure small currents of 2A or less and is fused.
 - In circuit lab you will have two multimeters, one is configured to measure currents, and the other is configured to measure voltages and resistances. So, cables are connected to the appropriate ports, and you do not need to reconnect them each time you want to measure a different quantity.
- **Measuring resistance:**
- Use the multimeter configured to measure voltage and resistance (the one with the red cable attached to the (V- Ω) port). To measure resistance, you need to set the multimeter to the resistance mode by pushing the '**K Ω** ' button.

- You must connect the Ohmmeter cables **in parallel** with the element in the circuit for which you want to measure the resistance, as shown in figure 1.5.

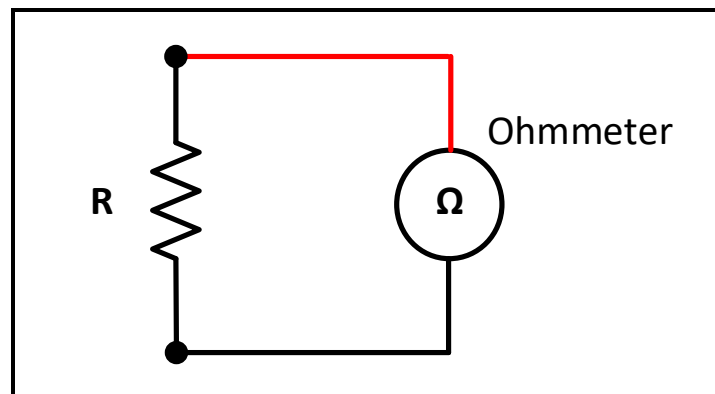

Figure 2.5: Multimeter connection to measure resistance.

- An Ohmmeter usually employs an internal battery across the resistance you are trying to measure. The battery drives a current into the resistor, which is measured by a current sensor. The value of the resistance is calculated by dividing the battery voltage by the current. **Hence, be careful not to connect any external power supply to the resistor you are trying to measure because an extra current can damage the ohmmeter.** Also isolate the resistor you want to measure from the circuit, since the multimeter calculates the overall Thevenin resistance connected to its terminals.
- Selecting suitable range:** You will see numbers appear on the multimeter display.
 - If these numbers are all zero, then the range setting on the multimeter is too high and you should lower it. The range of measurement is selected by the buttons below the multimeter display.
 - If only the number 1 appears in the left most position, then the range setting is too low and the resistance value is 'out of range'. In this case, increase the range setting.
 - If the display shows actual values, then this is the value of the resistor. Try out different range settings to see which one gives you the most precision.
 - Remember to check your range setting before reading the display e.g. if the range setting is 20 KΩ the display unit is kΩ, if it is 200 Ω the display unit is Ω.
- **Measuring voltage:**
 - Use the multimeter configured to measure voltage and resistance (the one with the red cable attached to the (V-Ω) port). To measure voltage, set the multimeter to the voltage mode by pushing the 'V' button.
 - A voltmeter is connected **in parallel** with the circuit element where the voltage measurement is desired as shown in figure 2.6. Since the voltage across parallel elements

is the same, the voltage measured by the meter will be the same as the voltage across the element to which the meter is connected.

- The internal impedance of the voltmeter is very large, to avoid drawing extra current, thus disturbing the voltage it is trying to measure.

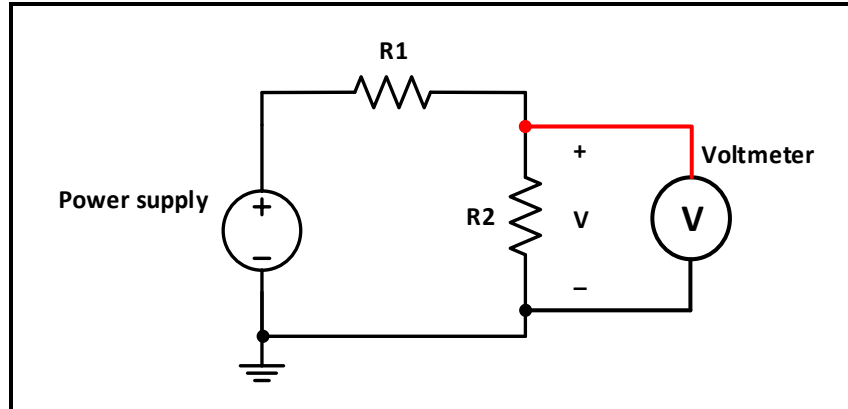

Figure 2.6: Multimeter connection to measure voltage.

- There are two different types of voltage measurements: AC and DC. The button to the left of the voltage mode button toggles the multimeter from AC to DC mode.
- When measuring voltage in DC mode, the multimeter measures the time average of the signal. In AC mode, the multimeter measures the R.M.S (root mean square) of the signal.
- **A common mistake** is to measure AC voltage in DC mode, the reading will be zero since the average value of AC voltage is zero.
- The red cable is connected to the higher voltage, while the black cable is connected to the lower voltage to produce positive measurement in DC mode.

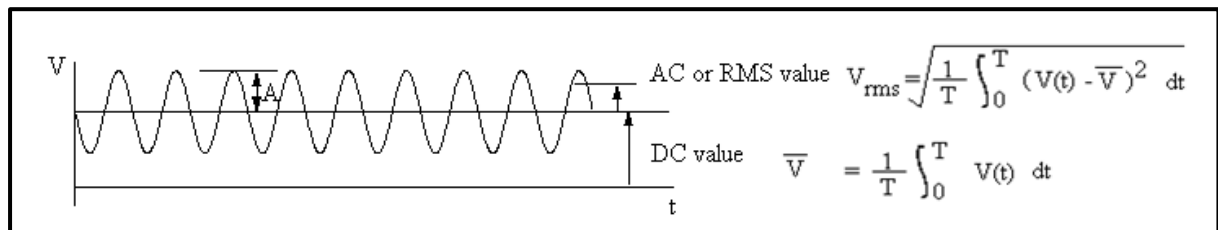

Figure 2.7: Sinusoidal signal

- **Selecting suitable range** for voltage measurement is done in the same way for resistance measurement. Note that the unit of measurement is (mV) or (V) depending on the selected range.
- **To protect the instrument**, you should always select the highest range first when making measurements of unknown voltages, then lower it till you find the suitable range.

- Measuring current:

- Use the multimeter configured to measure current (the one with the red cable attached to the (2A) port). To measure current, set the multimeter to the current mode by pushing the 'mA' button.
- An ammeter is connected **in series** with the element in the circuit through which you want to measure the current. This means, for example, if you want to measure the current through a cable between two devices, you will have to disconnect that cable, and reconnect it through the meter, as shown in figure 2.8.
- Since the current in each element of a series circuit is the same, the current flow through the meter will be the same as the current flow to the element of interest.
- The ammeter has a very small internal resistance so it does not disturb the current it is trying to measure. Due to this fact, however, **if it is connected by accident in parallel with the circuit element, a large amount of current will flow through it, thus damaging it. That is why ammeters are usually protected by a current limiting fuse.**

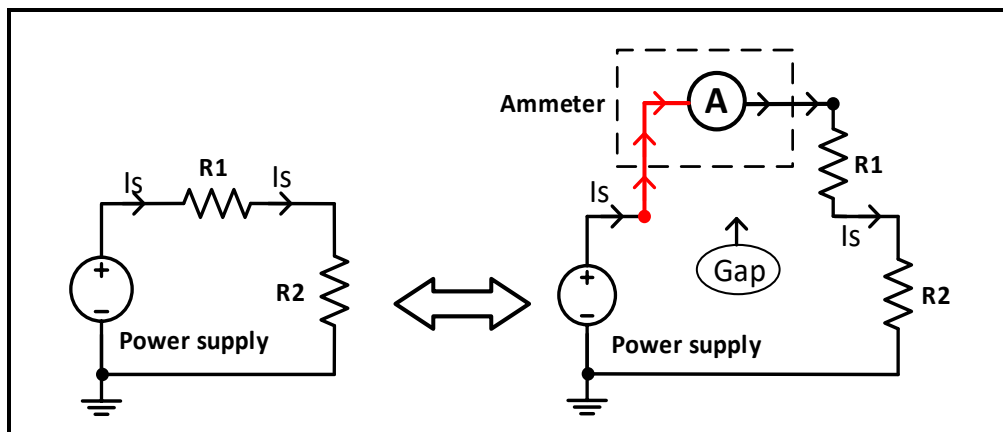

Figure 2.8: Multimeter connection to measure current.

- Current measurement has AC and DC modes similar to voltage measurement.
- The red cable is connected such that the current flows into it and leaves out the black cable to produce positive measurement in DC mode.
- **Selecting suitable range** for current measurement is done in the same way for resistance measurement. Note that the unit of measurement is (mA) or (μ A) depending on the selected range.
- **To protect the instrument**, you should always select the highest range first when making measurements of unknown currents, then lower it till you find the suitable range.

- **Function Wave Generator:**

The function generator can be used to produce three different kinds of signals as a function of time, square wave, triangular wave and sine wave.

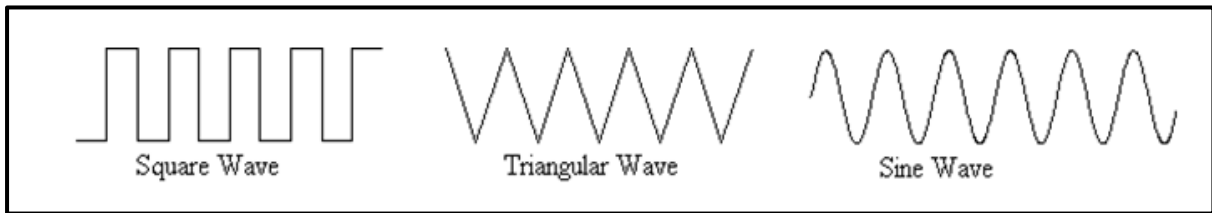

Figure 2.9: Waveforms

The function buttons determine the type of signal the instrument produces. With the sine-wave button pushed in, a sine wave will be produced, for example. The function generator also has range settings to determine the frequency range of the signal. The amplitude of the output signal is controlled using “AMPL” knob. The Function Wave Generator used in lab is the GFG-8215a as shown in Figure 1.10



Figure 2.10: Function Wave Generator GFG-8215a

- **Oscilloscope:**

The oscilloscope is a device designed to display a voltage signal in visual form. It can be used for some quantitative measurements, such as voltage amplitude and frequency, it also can be used to compare two separate signals and estimate their relative characteristics. The scope used in lab is the Tektronix TDS 2002B as shown in Figure 2.11.

- **Basic Set Up:**

The oscilloscope is turned on using the power button indicated in figure 2.11. After a few seconds a horizontal line should appear on the screen. The line, called a 'trace' is a plot of voltage (on the vertical scale) against time (on the horizontal scale).

- **Note:** Autoset button used to get the signal direct without any setting on oscilloscope.



Figure 2.11: Oscilloscope Tektronix TDS 2002B

The TDS 2002B is a digital oscilloscope that functions very much like a computer. Most of the settings can be changed through various menus accessible from the top control panel:

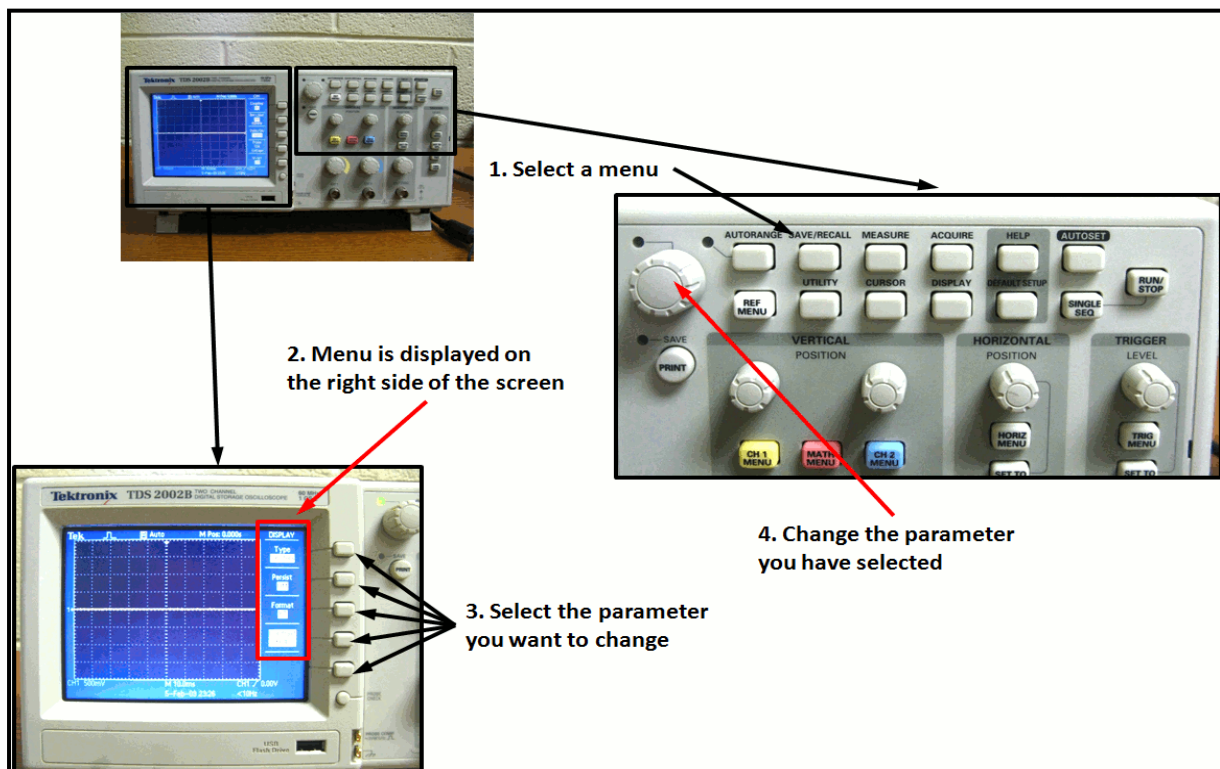

Figure 2.12: Oscilloscope menu

Note that the oscilloscope screen has graduations (or 'divisions'). This is to enable you to make quantitative measurements of signals displayed. You can also try the *MEASURE* and *CURSOR* menus. The *MEASURE* menu allows you to measure various quantities (frequency, mean, peak-to-peak, etc...) for one or two channels. The *CURSOR* menu uses two lines to measure any feature on the vertical or horizontal axes. Try these out for yourself. In the section of the front panel labeled "VERTICAL" set the **CH 1 MENU** and **CH 2 MENU** In the HORIZONTAL section set the SEC/DIV knob to 5ms/div (as you turn the

knob, you should see the value at the bottom of the screen (just above the date) change). You should see a trace on the screen. Adjust the intensity and focus if needed. Center the line using the position knobs in the HORIZONTAL and VERTICAL sections.

- **Connecting Signals:**

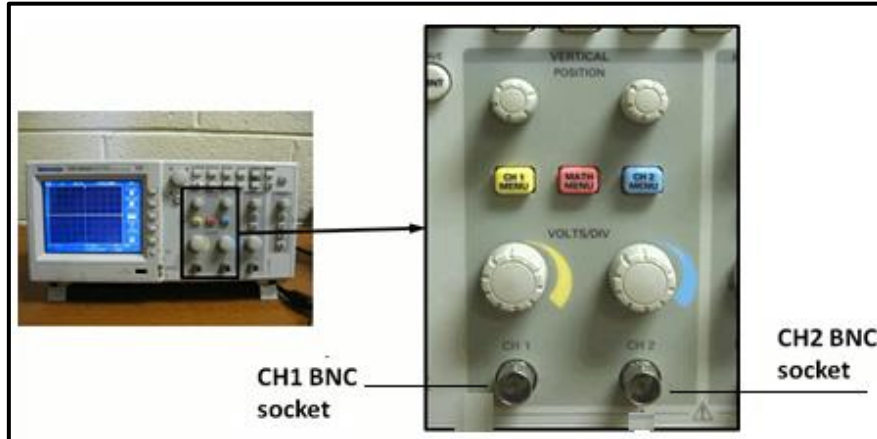

Figure 2.13: connecting signals to oscilloscope

Signals are connected to the scope through one of two BNC sockets, located as shown above. These accept cables with connectors of the type shown below.



BNC connector

There are two sockets, because the scope can simultaneously display up to two signals. The signals and connectors are identified as CH 1 and CH 2, for channels 1 and 2. Note that the signal is actually provided to the scope through the central pin of the BNC sockets. The outer shield is a ground connection (not just a common) **so you must be a little careful what you connect to it. (E.g. if you set the power supply to provide 5V relative to ground and then connect the 5V to the BNC shield the resulting mismatch might cause problems the scope.)**

When you have made your connections, you need to tell the oscilloscope what to display using the **CH 1 MENU** and **CH 2 MENU** buttons. Pressing these buttons will toggle the display of their respective channel. Channel 1 signal appears as a yellow trace, while Channel 2 signal is blue. It is therefore possible to display the signals from both channels at the same time.



The **MATH MENU** button can be used to display an arithmetic combination of two signals. You can select from addition, subtraction, multiplication, addition or Fourier Transform (FFT). The resulting signal is plotted in red.

- Setting the Vertical Scale:

Scopes give you the same control over displaying a signal as you would have over plotting it on a piece of graph paper. You can independently control the origin and the scale of the voltage displayed on the vertical axis. There are duplicate controls for the two channels.

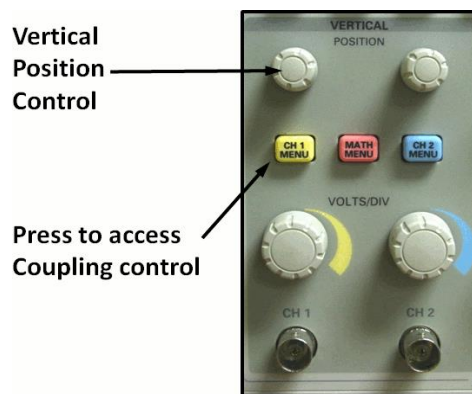

The vertical 'POSITION' controls are used to set the origin. Turning the POSITION control for CH1 for examples simply moves the signal up and down on the screen (i.e. the origin is moving up and down). If your objective is to make an absolute voltage measurement (rather than just look at the form of the signal) you will want to know quantitatively where the origin you've set is. You can do this by selecting GND coupling to plot zero volts on the screen.

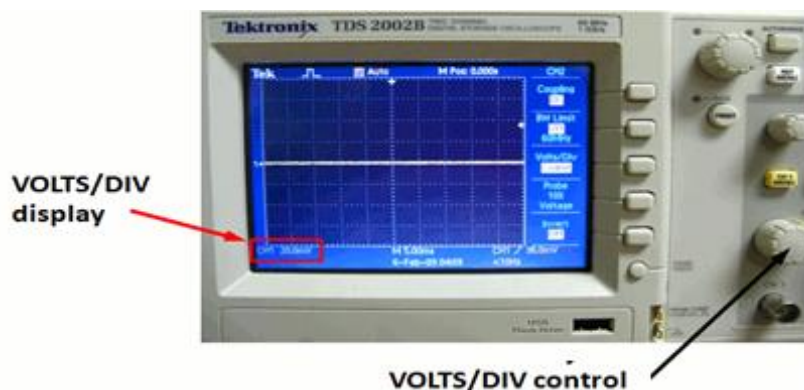

For controlling the scale of the voltage axis there is a VOLTS/DIV control. This sets the voltage represented by each of the large vertical divisions on the screen. The actual value set is indicated by the number in their lower left corner of the screen and may be varied from 5 mV per division to 5 V per division.

If you need finer resolution in the increments of VOLTS/DIV you can press the **CH 1 MENU** and change *Volts/Div* from Coarse to Fine. Note that it is perfectly possible to set the

POSITION and/or VOLTS/DIV control so that the signal you want to look at, or even the voltage origin, is off the screen so that you see no trace. If you think this has happened the best way to get your signal back is to increase the VOLTS/DIV setting, and then to rotate POSITION knob until the trace appears.

- **Setting the Horizontal Scale:**

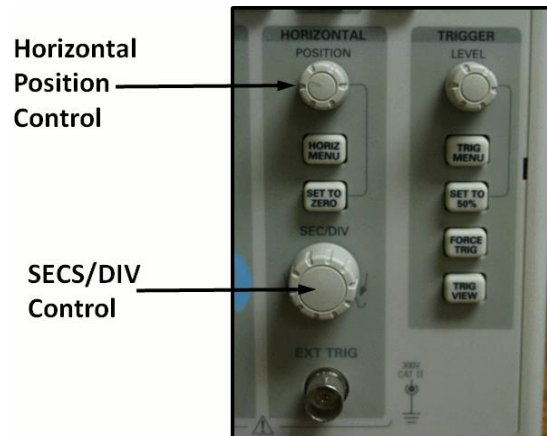

The controls for the horizontal (time) axis are located as shown in the picture. The same horizontal scale is used for both channels, so there is only one set of controls. For controlling the time origin (i.e. for moving the signal horizontally across the screen) there is a POSITION control. For controlling the scale of the time axis there is a knob labeled 'SEC/DIV'. This sets the time represented by each of the large horizontal divisions on the screen. The actual value set is indicated at the bottom of the screen (just above the date) and may be varied from 5 nanoseconds per division to 50 seconds per division.

- **Resistor Color Code:**

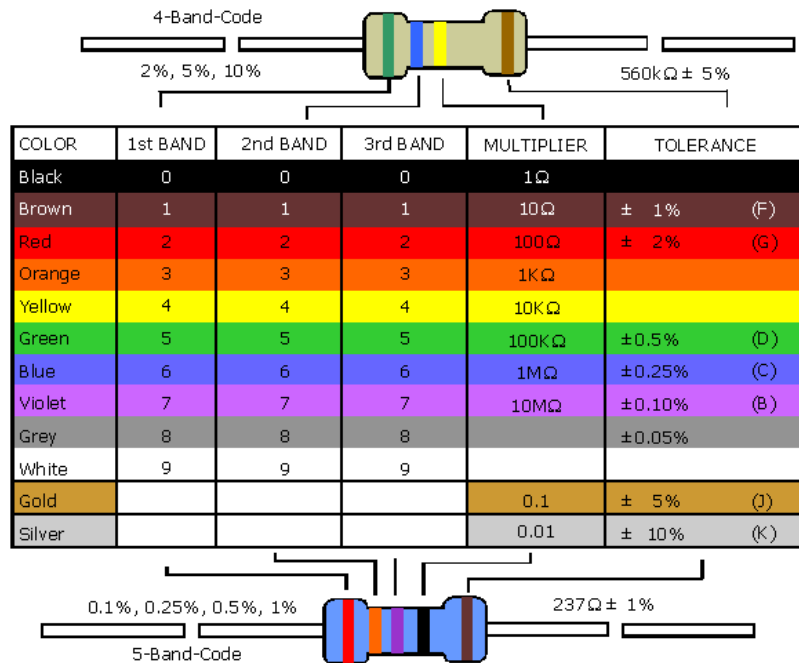

➤ **Procedure**

Part A: Measuring resistance

1. Use digital multi meter (DMM) to measure resistances you have been given, record results.

Part B: Measuring voltage

1. Connect the circuit shown in figure 2.14, set the input power supply to 10V, measure the voltage across each resistor, record and discuss results.

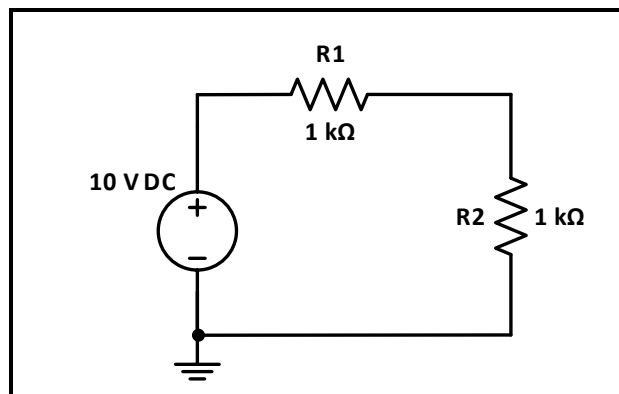

Figure 2.14

Part C: Measuring current

1. For the same circuit of figure.2.14 measure the current through each resistor, record and discuss results.

Part D: Using oscilloscope and function wave generator

1. Connect the circuit shown in Figure 2.15, set the input voltage to sinusoidal voltage at 8 V_{PP} and 1 kHz (you will need to connect channel 1 of the oscilloscope to the input voltage).

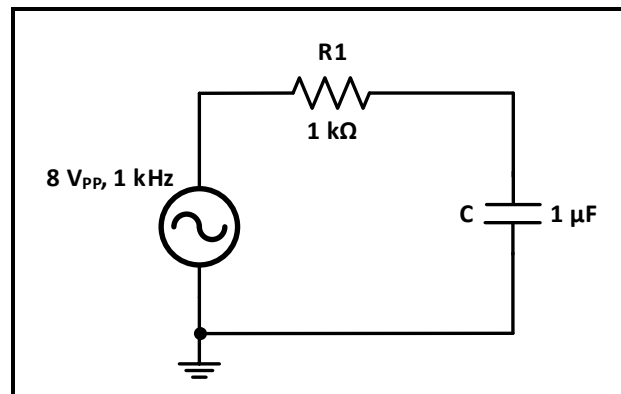

Figure 2.15

2. Connect channel 2 of the oscilloscope to the capacitor, use measure menu to view characteristics of the voltage across capacitor.
3. Use DMM to measure the current in the circuit, and the voltage across the resistor and the capacitor.

Experiment 3

Simple Resistive Circuits

➤ **Objectives:**

1. To verify the KVL and KCL.
2. To verify the voltage divider rule.
3. To verify the current divider rule.
4. To examine the effects of short and open circuited resistor in electrical circuits.

➤ **Equipment Required:**

1. Digital Multimeter.
2. Power Supply.
3. Board, wires, and resistances.

➤ **Introduction:**

Kirchhoff's Voltage Law: states that the algebraic sum of all the voltages around any closed path (loop or mesh) is zero.

Applying Kirchhoff's voltage law to the first and the second loops in the circuit shown in Figure 3.1 yields:

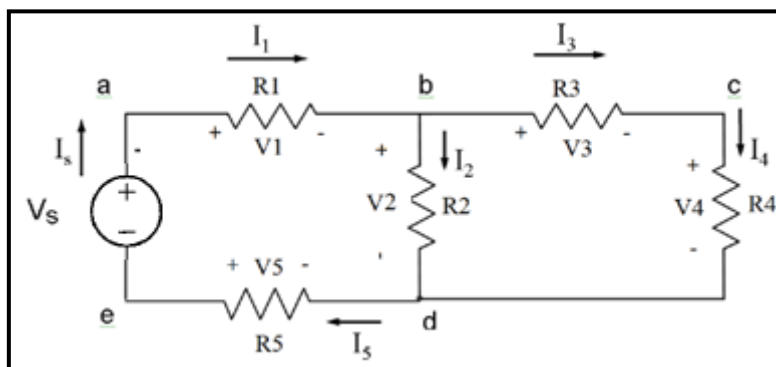

Figure 3.1

Loop 1: $-V_s + V_1 + V_2 - V_5 = 0$ 1- a

Loop 2: $-V_2 + V_3 + V_4 = 0$ 1- b

Kirchhoff's Current Law: states that the algebraic sum of all the currents at any node is zero. Applying Kirchhoff's current law to the first four nodes in the circuit shown in Figure 2.1 yields the following equations;

Node a: $-I_s + I_1 = 0$ (2-a)

Node b: $-I_1 + I_2 + I_3 = 0$ (2-b)

Node c: $-I_3 + I_4 = 0$ (2-c)

Node d: $-I_2 - I_4 + I_5 = 0$ (2-d)

The Voltage-Divider and Current-Divider Circuits

At times—especially in electronic circuits—developing more than one voltage level from a single voltage supply is necessary. One way of doing this is by using a **voltage-divider circuit**, such as the one in Figure 3.2.

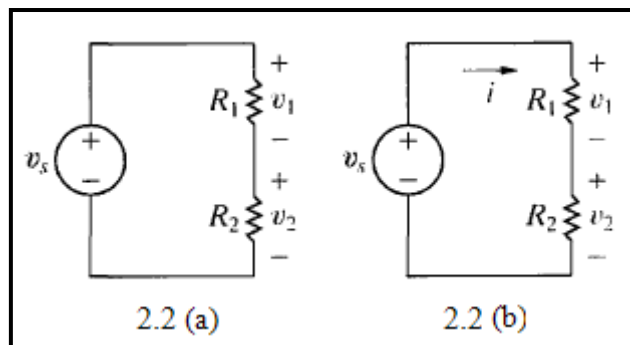

Figure 3.2 (a) A voltage-divider circuit and (b) the voltage-divider circuit with current *i* indicated.

We analyze this circuit by directly applying Ohm's law and Kirchhoffs laws. To aid the analysis, we introduce the current *i* as shown in Figure 2.2 (b). From Kirchhoffs current law, R1 and R2 carry the same current. Applying Kirchhoffs voltage law around the closed loop yields

$v_s = iR_1 + iR_2$(3)

$i = \frac{v_s}{R_1 + R_2}$ (4)

Now we can use Ohm's law to calculate *v*1 and *v*2:

$v_1 = iR_1 = v_s \frac{R_1}{R_1 + R_2}$ (5)

$v_2 = iR_2 = v_s \frac{R_2}{R_1 + R_2}$ (6)

Equations (5) and (6) show that v_1 and v_2 are fractions of v_s . Each fraction is the ratio of the resistance across which the divided voltage is defined to the sum of the two resistances. Because this ratio is always less than 1.0, the divided voltages v_1 and v_2 are always less than the source voltage v_s .

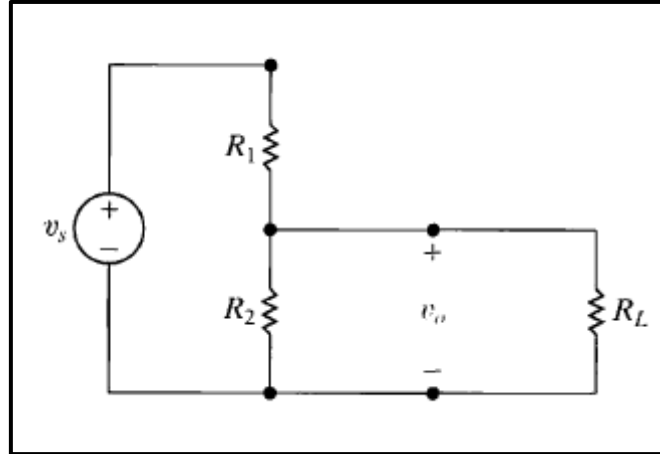

Figure 3.3: A voltage divider connected to a load R_L

If you desire a particular value of v_2 , and v_s is specified, an infinite number of combinations of R_1 and R_2 yield the proper ratio. For example, suppose that v_s equals 15 V and v_2 is to be 5 V. Then $v_2/v_s = 1/3$ and, from Eq. 2, we find that this ratio is satisfied whenever $R_2 = 0.5 R_1$. Other factors that may enter into the selection of R_1 and hence R_2 , include the power losses that occur in dividing the source voltage and the effects of connecting the voltage-divider circuit to other circuit components. Consider connecting a resistor R_L in parallel with R_2 , as shown in Figure 2.3. The resistor R_L acts as a load on the voltage-divider circuit. A **load** on any circuit consists of one or more circuit elements that draw power from the circuit. With the load R_L connected, the expression for the output voltage becomes

$$v_o = \frac{R_{eq}}{R_1 + R_{eq}} v_s \dots\dots\dots(7)$$

$$R_{eq} = \frac{R_2 R_L}{R_2 + R_L} \dots\dots\dots(8)$$

$$v_o = \frac{R_2}{R_1 [1 + (R_2/R_L)] + R_2} v_s \dots\dots\dots(9)$$

Note that Eq.(9) reduces to Eq.(6) as $R_L \rightarrow \infty$, the voltage ratio v_o/v_s is essentially undisturbed by the addition of the load on the divider. Another characteristic of the voltage-divider circuit of interest is the sensitivity of the divider to the tolerances of the resistors. By tolerance we mean a range of possible values. The resistances of commercially available resistors always vary within some percentage of their stated value.

➤ **Prelab:**

**** (Refer to procedure section for circuits figures)**

When asked to find voltages and currents using PSPICE, you have to attach a clear picture of your PSPICE circuit in your pre-lab document with voltages and current shown on it, **in all experiments of this manual.**

• **Part A: Kirchhoff's Laws**

1. Simulate the circuit of Figure 3.4 using PSPICE to find the voltage across and the current through each resistor.

• **Part B: Voltage Divider**

1. Simulate the circuit of Figure 3.5 using PSPICE to find the voltages V_{1-2} , V_{2-3} , and V_{3-0} .
2. For the circuit of Figure 3.6: R_p is a 10 k Ω potentiometer (three-terminal resistor), Calculate R_{AB} and R_{BC} so that $V_o = 3$ V.
3. For the circuit shown in Figure 3.7, use PSPICE to find the value of V_o for $R_L = 1$ k Ω , 10 k Ω , 100 k Ω , 500 k Ω .

• **Part C: Current Divider**

1. Simulate the circuit of Figure 3.8 using PSPICE to find the value of current in each resistor in the circuit.

• **Part D: Short-and-Open Circuited Resistor in Series-Parallel Circuits**

1. Simulate the circuit of Figure 3.9 using PSPICE to find the voltage across and the current through each resistor.

➤ **Procedure:**

Part A: Kirchhoff's Laws

1. Connect the circuit of Figure 3.4, set V_{in} to 10 V.

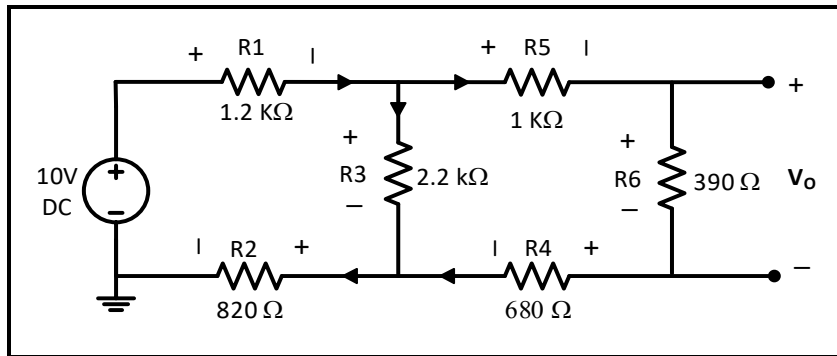

Figure 3.4

2. Measure the current through and the **voltage drop across** each resistor using Digital Multimeter (DMM), record results in Table 3.1.

Question 1: Using measured values of I and V , verify KCL on the upper middle node, verify KVL on the left loop.

Part B: Voltage Divider

1. For the circuit of Figure 3.5:

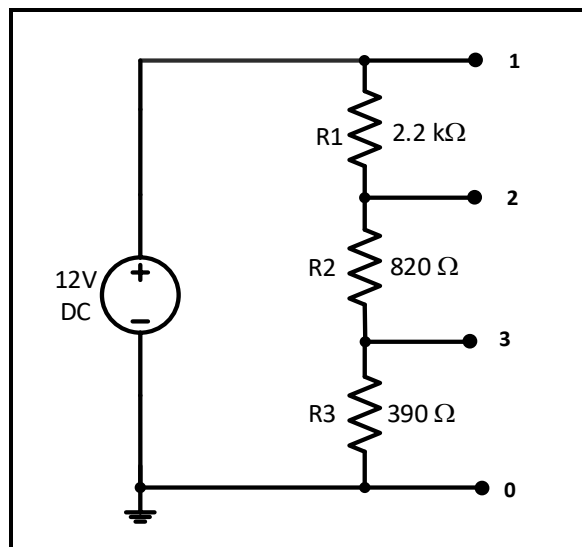

Figure 3.5

- a. Connect the circuit, set the power supply output to 12 V.
- b. Measure voltages V_{1-2} , V_{2-3} , and V_{3-0} , record results in Table 3.2.

Question 2: From measured values, around which resistor did the largest and smallest voltage drops occurred? Explain why?

Question 3: Using measured values of V , verify that $(V_{1-2} + V_{2-3} + V_{3-0} = 12V)$.

2. For the circuit of Figure 3.6:

- a. Connect the circuit with the power supply set to 12 V.
- b. Change the pot. till $V_o = 3V$, measure R_{AB} , R_{BC} and record results in Table 3.3.

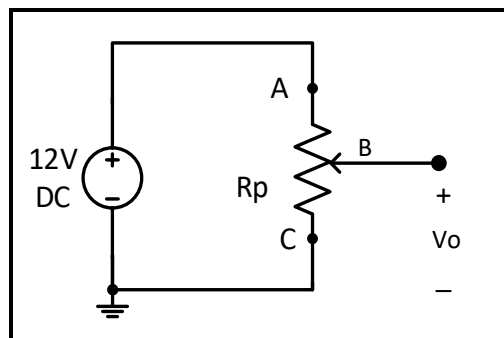

Figure 3.6

3. Connect the circuit of Figure 3.7.

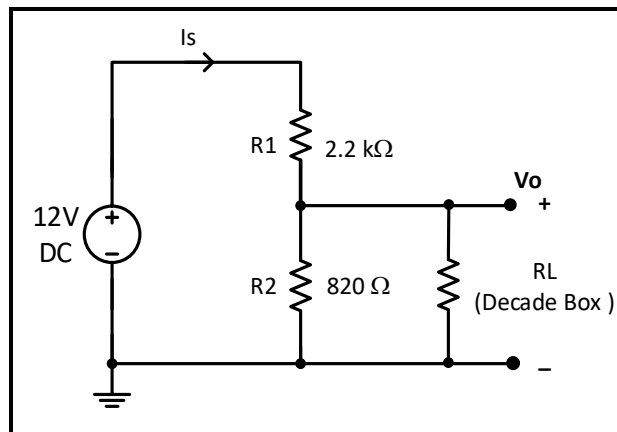

Figure 3.7

- a. Measure V_o for $R_L = 1\text{ k}\Omega$, $10\text{ k}\Omega$, $100\text{ k}\Omega$, $500\text{ k}\Omega$ and ∞ , record results in Table 3.4.

Question 4: Using measured values, plot V_o vs. R_L . Explain the change in V_o as R_L is changed.

Part C: Current Divider

1. Connect the circuit shown in Figure 3.8, set V_{in} to 15 V.

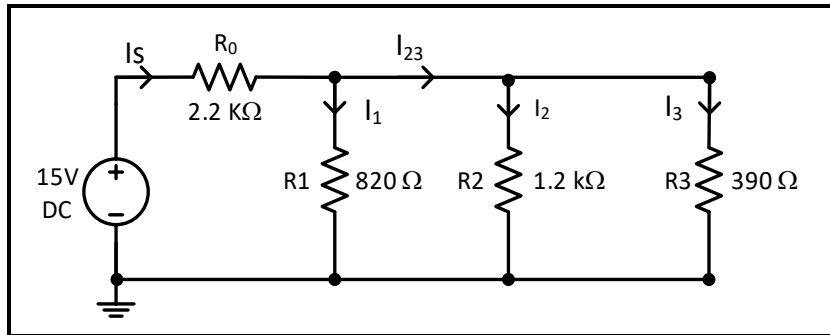

Figure 3.8

2. Measure the values of I_s , I_1 , I_{23} , I_2 , and I_3 , record results in Table 3.5.

Question 5: From measured values of I , through which resistor did the largest and smallest currents passed? Explain why?

Question 6: Using measured values of I , verify that $(I_s = I_1 + I_2 + I_3)$.

Part D: Short-and-Open Circuited Resistor in Series-Parallel Circuits

1. Connect the circuit of Figure 3.9, set V_{in} to 12 V.

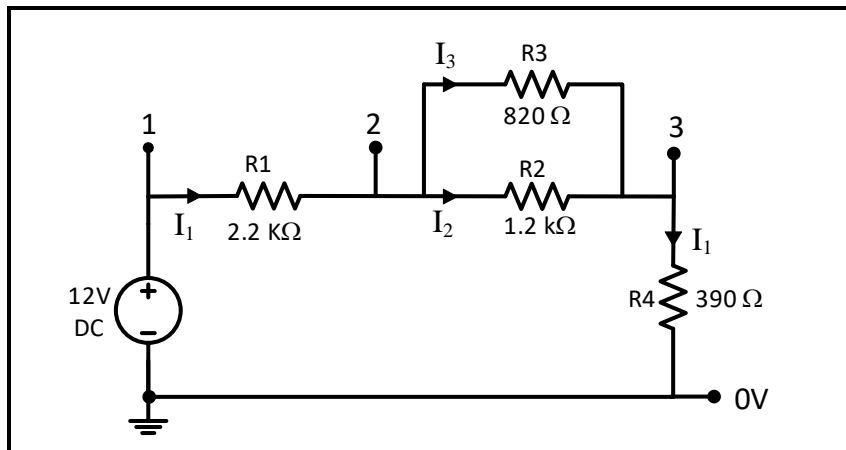

Figure 3.9

2. Measure voltages V_{1-2} , V_{2-3} , and V_{3-0} , and currents I_1 , I_2 , and I_3 , record results in Table 3.6.
3. **Replace R_1 by a short circuit.** Measure the resulting voltages V_{1-2} , V_{2-3} , and V_{3-0} , and currents I_1 , I_2 , and I_3 , record results Table 3.6.
4. Reinsert R_1 back in the circuit, replace R_2 by short circuit, repeat same measurements in step (3), and record results in Table 3.6.
5. Return the circuit to the original state of figure 3.9, consider now **removing R_1** . Measure the resulting voltages V_{1-2} , V_{2-3} , and V_{3-0} , and current I_1 if this were to occur. Record results in Table 3.7.

6. Reinsert R_1 back in the circuit, remove R_2 , repeat same measurements in step (5), and record results in Table 3.7.

Question 7: What is the value of the short circuit voltage? Is there any current in the circuit when a resistor is open circuit?

Before Leaving the Laboratory

Be sure the following is completed before you leave the laboratory.

- (a) Check to be sure that you have all the required measured values.
- (b) Have the laboratory instructor check your laboratory readings.
- (c) Restore your laboratory station (equipment and chairs) to the condition they were in when you arrived.

Thank you for your cooperation.

Experiment 4

Network Theorems

➤ **Objectives:**

1. To verify the proportionality and superposition theorems.
2. To verify Thevenin's theorem.
3. To verify that a network can be replaced by an equivalent Δ -Y network.
4. To verify the reciprocity theorem of single-source DC network.

➤ **Equipment Required:**

1. Digital Multimeter.
2. Power Supply.
3. Board, wires, and resistances.

➤ **Introduction:**

Solving for currents and voltages in multi-loop electric circuits can be quite complicated, particularly for AC circuits. The Kirchhoff's voltage law and Kirchhoff's current law always apply but using them may lead to long systems of equations. Certain theorems help with network analysis:

Superposition Theorem:

For multiple-source circuits, the circuit respond from each source can be calculated individually, and the results added (superimposed).

Thevenin's Theorem:

Combinations of voltage sources and resistors with two terminals can be replaced by a single ideal voltage source and a series resistor.

Delta-to-Wye (Pi-to-Tee) Equivalent Circuits:

Any pi network can be transformed to an equivalent T network. This is also known as the Wye-Delta transformation, which is the terminology used in power distribution and electrical engineering. The pi is equivalent to the Delta and the T is equivalent to the Wye (or Star) form

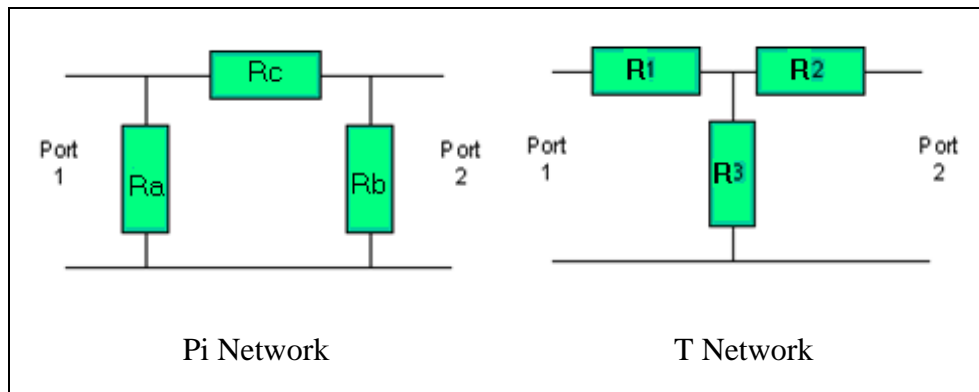

The impedances of the pi network (R_a , R_b , and R_c) can be found from the impedances of the T network with the following equations:

$$R_a = (R_1 * R_2) + (R_1 * R_3) + (R_2 * R_3) / R_2$$

$$R_b = (R_1 * R_2) + (R_1 * R_3) + (R_2 * R_3) / R_1$$

$$R_c = (R_1 * R_2) + (R_1 * R_3) + (R_2 * R_3) / R_3$$

Note the common numerator in all these expressions which can prove useful in reducing the amount of computation necessary.

The impedances of the T network (R_1 , R_2 , R_3) can be found from the impedances of the equivalent pi network with the following equations:

$$R_1 = (R_a * R_c) / (R_a + R_b + R_c)$$

$$R_2 = (R_b * R_c) / (R_a + R_b + R_c)$$

$$R_3 = (R_a * R_b) / (R_a + R_b + R_c)$$

Note the common denominator in these expressions.

➤ **Prelab:**

**** (Refer to procedure section for circuits figures)**

Part A: Proportionality

1. For the circuit of Figure 4.1, use PSPICE to generate a plot of (V_O) (use differential voltage marker), for a V_{in} sweep from 0 to 15 V in a 1.5V step, use cursors to mark data point at $V_{in} = 5$ and 10 V.

Part B: Superposition

1. Use PSPICE to determine the voltages at all nodes and the current in all the branches for the circuits in **Figures 4.2 to 4.4**.

Part C: Thevenin's Theorem

1. Find and draw the Thevenin equivalent with respect to the terminals X, Y for the circuit in Figure 4.5 (**Show calculation of $V_{Thevenin}$ and $R_{Thevenin}$**).
2. Simulate the circuit of Figure 4.5 using PSPICE to determine the value of voltage around and current through the 680 Ω resistor.
3. Simulate Thevenin equivalent circuit that you found in step 1 shown in Figure 4.7 using PSPICE to determine the value of voltage around and current through the 680 Ω resistor.

Part D: Δ -Y Transformation

1. For the circuit of Figure 4.8 calculate the equivalent Y for the Δ formed by the three 3.3k Ω resistors, draw the resulting circuit.
2. Simulate the circuit of Figure 4.8 using PSPICE, find the value of the current I, and calculate voltage V_{ab} from simulation results.
3. Simulate the circuit resulting from replacing the Δ formed by 3.3 k Ω resistors with the equivalent Y found in step 1.

Part E: Reciprocity Theorem

1. Simulate the circuits of Figure 4.9 and Figure 4.10 using PSPICE to find the value of the current (I).

➤ **Procedure:**

Part A: The Proportionality Theorem

1. Connect the circuit of Figure 4.1.

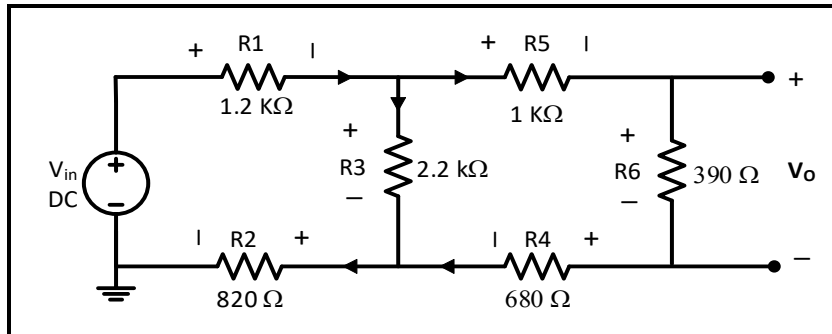

Figure 4.1

2. Set V_{in} to 5 then 10 V respectively. In each case measure V_o and record it in Table 4.1.

Question 1: Using measured values of V_o calculate K for both cases in the previous step, record results in Table 4.1. Compare results and discuss.

Part B: The Superposition Theorem

1. Connect the circuit of Figure 4.2 and set the power supply voltages as indicated.

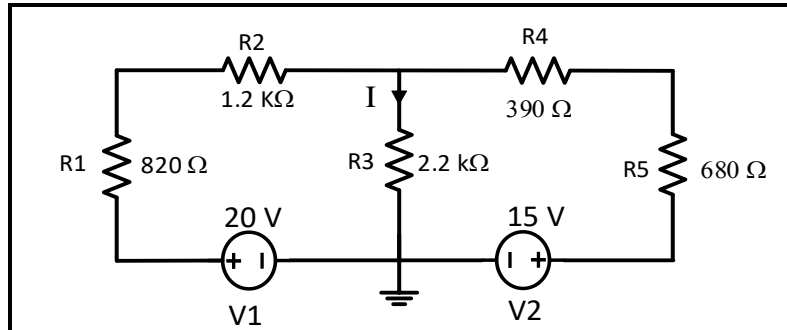

Figure 4.2

2. Measure the voltage across and the current through the 2.2 kΩ resistor, record results in Table 4.2.
3. Connect the circuit of Figure 4.3.

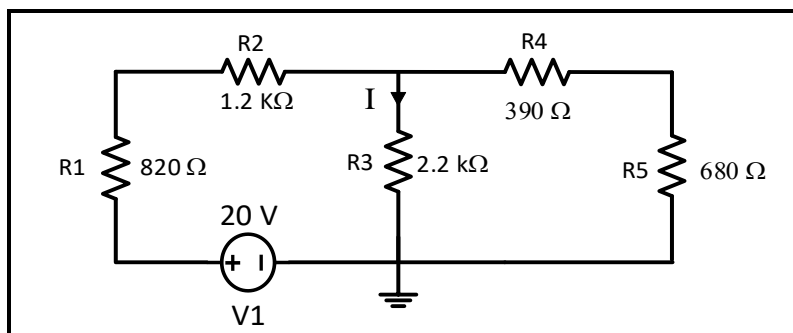

Figure 4.3

4. Measure the voltage across and the current through the $2.2\text{ k}\Omega$ resistor, record results in Table 4.2.
5. Connect the circuit of Figure 4.4

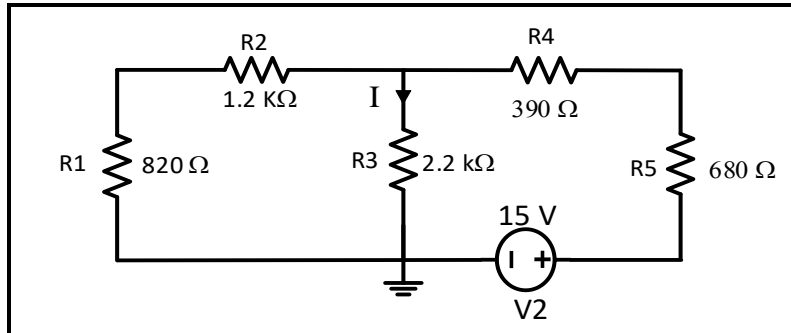

Figure 4.4

6. Measure the voltage across and the current through the $2.2\text{ k}\Omega$ resistor, record results in Table 4.2.

Question 2: Add the voltage and current measurements made in steps 2 and 4 record results in Table 4.2. Does the sum equal the voltage and current measurement in step 6?

Part C: Thevenin Theorem

1. Connect the circuit of Figure 4.5 and set the power supply voltage to 10V.

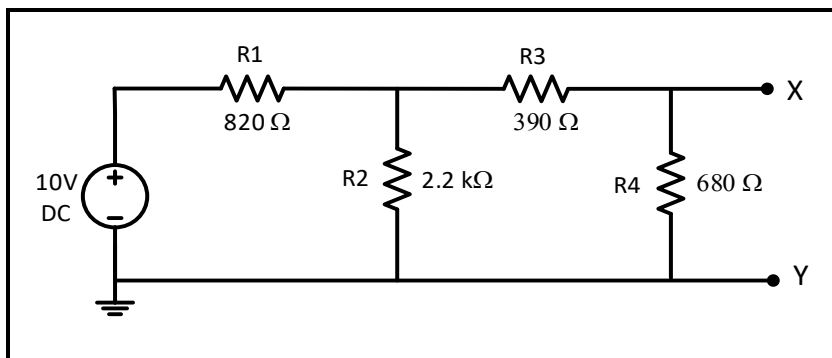

Figure 4.5

2. Measure the voltage across and the current through the $680\ \Omega$ resistor, record results in the Table 4.3.
3. Remove the $680\ \Omega$ resistor from the circuit and measure the open circuit voltage between terminals X and Y, record results in the Table 4.4.
4. Short circuit the terminals X and Y and measure the short circuit current I_{XY} , record results in the Table 4.4.

5. The first method to calculate R_{Th} is by: $R_{Th} = \frac{V_{OC}}{I_{SC}}$, calculate R_{Th} and record result in Table 4.4.
6. The second method to calculate R_{Th} is by using test voltage source. First kill all independent sources in the circuit (set the voltage source to zero as shown in figure 4.6)
7. Connect a 4 V test voltage source to points X and Y, measure the resulting current, and finally calculate $R_{Th} = \frac{V_T}{I_T}$. Record results in Table 4.5

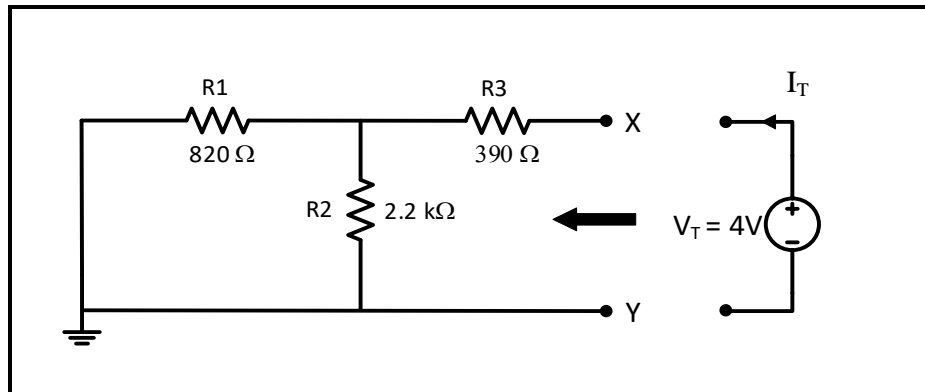

Figure 4.6

8. The third method to calculate R_{Th} is by connecting an **ohm meter** between points X and Y in place of the test source in figure 4.6, **measure R_{Th}** , record result in Table 4.6.
9. Based on your calculation of $V_{Thevenin}$ and $R_{Thevenin}$ in your pre lab, connect Thevenin's equivalent circuit for the circuit of Figure 4.5 as shown in figure 4.7 (use decade box for $R_{Thevenin}$), measure the voltage across and the current through the 680 Ω resistor, record results in Table 4.7.

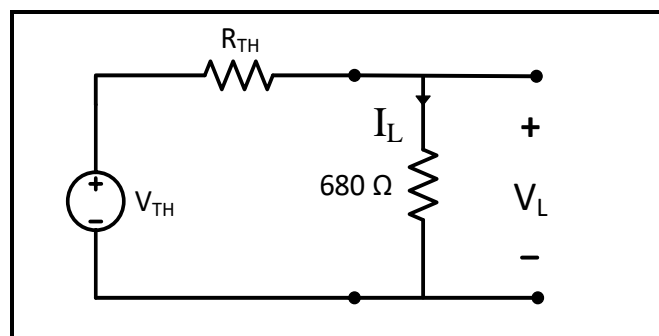

Figure 4.7

Question 3: Compare the measured values of load voltage and current in Thevenin's circuit and in the original circuit in figure 4.5. Compare the value of R_{Th} in the three methods of measurement.

Part D: Δ -Y Transformation

1. Connect the circuit of Figure 4.8.

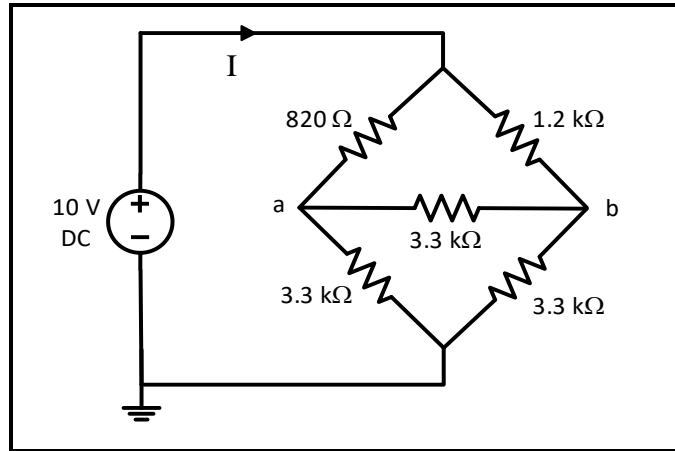

Figure 4.8

2. Measure the current I and the voltage V_{ab} , record results in the Table 4.8.
3. Connect the equivalent Y network you found in your pre-lab, measure the current I and the voltage V_{ab} , record results in the Table 4.8.

Question 4: Compare the values of I and V_{ab} in wye and delta circuits and discuss.

Part E: The Reciprocity Theorem

1. Connect the circuit of Figure 4.9, measure and record the current I in Table 4.9.

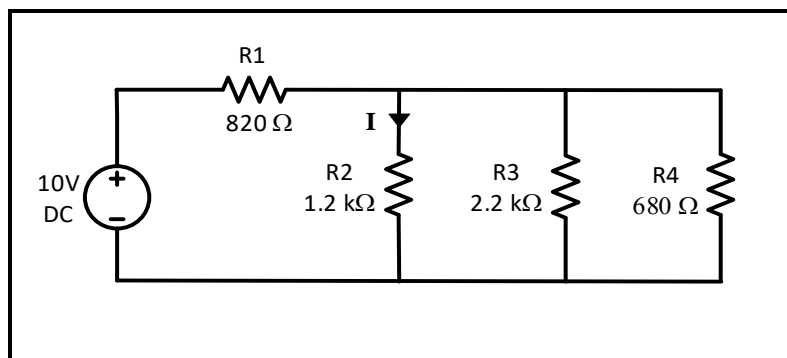

Figure 4.9

2. Connect the circuit of Figure 4.10, measure and record the current I in Table 4.9.

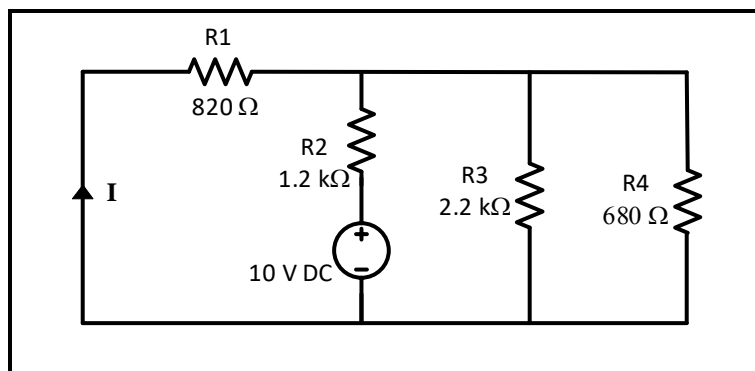

Figure 4.10

Question 5: Compare the currents measurements in steps 1 and 2.

Experiment 5

First and Second Order Circuits

➤ **Objectives:**

1. To examine the behavior of first-order circuits in response to a step input.
2. To examine the behavior of second-order circuits in response to a step input.

➤ **Equipment Required:**

1. Function generator
2. Digital Multimeter.
3. Oscilloscope
4. Board, wires, capacitors, inductor box, and resistances.

➤ **Introduction:**

- **First-Order Circuits with DC sources (Step Response):**

Unit Step function is defined as:

$$\begin{cases} u(t) = 0 & \text{for } t \leq 0^- \\ u(t) = 1 & \text{for } t \leq 0^+ \end{cases}$$

Defining $t' = t - t_0$, one can see that $u(t') = u(t - t_0)$ is:

$$\begin{cases} u(t - t_0) = 0 & \text{for } t \leq t_0^- \\ u(t - t_0) = 1 & \text{for } t \leq t_0^+ \end{cases}$$

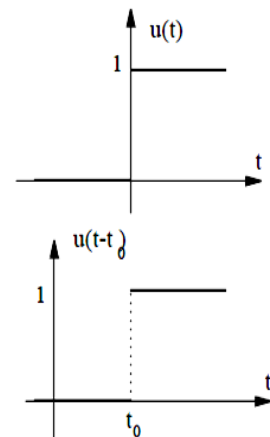

Step functions are one way to illustrate switched circuit as is shown in the following.

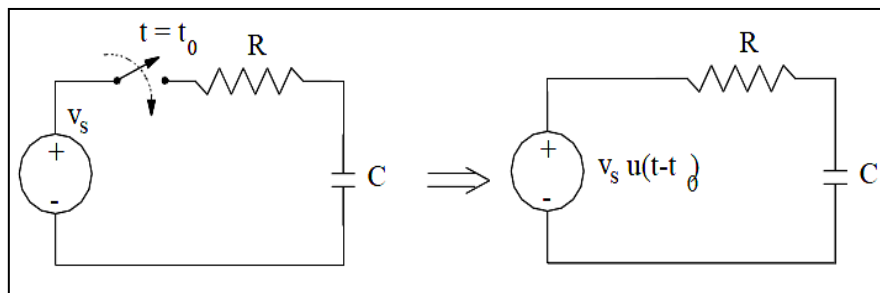

Figure 5.1

- **Step response of an RC circuit:**

Consider the RC circuit above. The switch closes at time $t = 0$ and the capacitor has an initial voltage of V_0 . For $t > 0$, KVL results in $Ri_c + V_C = V_s$, or:

$$RC \frac{dv_c}{dt} + v_c = V_s$$

$$V_c(0^+) = V_c(0^-) = V_0$$

We have found the natural solution to RC circuit to be:

$$v_{C,n} = K e^{-\frac{t}{\tau}} \quad \text{and} \quad \tau = RC$$

To find the forced response, $V_{C,f} = A$. Substituting for $V_{C,f}$ in the differential equation, we get:

$$RC \frac{dA}{dt} + A = V_s \quad \rightarrow \quad v_{C,f} = A = V_s$$

$$v_C = v_{C,n} + v_{C,f} = K e^{-\frac{t}{\tau}} + V_s$$

Constant K is found from the initial condition: $V_c(0^+) = V_c(0^-) = V_0$:

Thus, the capacitor voltage waveform is:

$$V_c(t) = K e^{-t/T} + V_s \quad \text{for } t \geq 0$$

$$V_c(0^+) = K + V_s$$

So

$$K = V_c(0^+) - V_s$$

$$V_c(t) = V_s + (V_c(0^+) - V_s) e^{-t/T}$$

$$V_c(\infty) = V_s$$

$$V_c(t) = V_c(\infty) + [V_c(0^+) - V_c(\infty)] e^{-t/T}$$

$$V_c(0^+) = \text{initial voltage}$$

$$V_c(\infty) = \text{Final voltage}$$

$$V_c(t) = V_c(\infty) + [V_c(0^+) - V_c(\infty)] e^{-t/T}$$

If we wait long enough, (mathematically: $t \rightarrow \infty$, practically: 5τ) the circuit will reach DC steady condition again, current in the capacitor becomes zero and its voltage reaches V_s as can be seen either from the circuit or from the expression for $V_C(t)$.

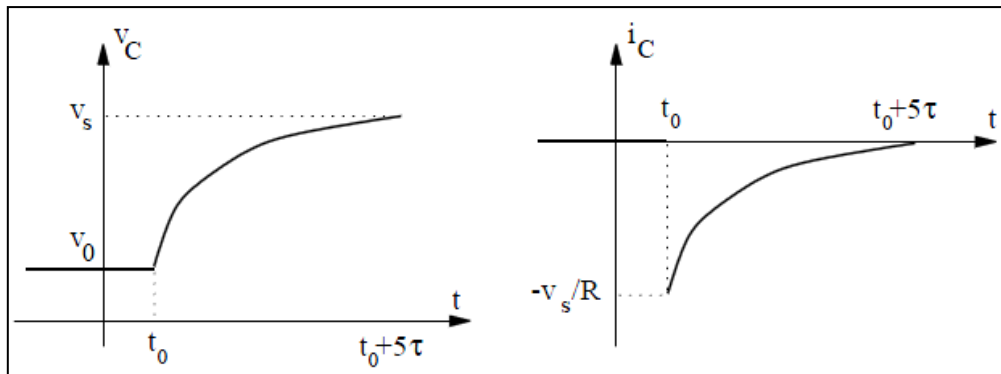

Figure 5.2

If the switch was closed at time $t = t_0$ instead of time zero, the capacitor voltage waveform would be:

$$v_C(t) = v_C(\infty) + [v_C(t_0^+) - v_C(\infty)] e^{-(t-t_0)/T}$$

Since V_0 is the initial value of V_C and V_s is its final value, the above equation can be re-written as:

$$v_C \text{ at Time } t = \left[\begin{array}{c} \text{Initial Value of} \\ v_C \end{array} - \begin{array}{c} \text{Final Value of} \\ v_C \end{array} \right] \times e^{-\frac{t-t_0}{\tau}} + \begin{array}{c} \text{Final Value of} \\ v_C \end{array}$$

In fact, all voltages and currents in the circuit (also called “Response”) will have the same waveform:

$$\text{Response at Time } t = \left[\begin{array}{c} \text{Initial Value of} \\ \text{Response} \end{array} - \begin{array}{c} \text{Final Value of} \\ \text{Response} \end{array} \right] \times e^{-\frac{t-t_0}{\tau}} + \begin{array}{c} \text{Final Value of} \\ \text{Response} \end{array}$$

- Step response of an RL circuit:

Consider the RL circuit shown in Figure 5.3

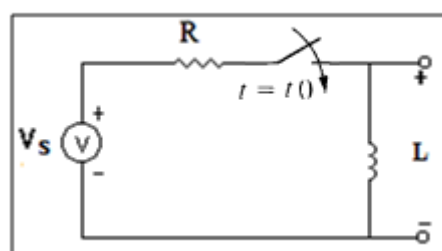

Figure 5.3

The switch closes at time $t = t_0$ and the inductor has an initial current of $I_L(t_0^-)$. We can find the inductor current waveform following the procedure similar to one used for step response of RC circuits. Alternatively, we can use the “Response” formula identified above. Here the response of interest is i_L . The time constant of the circuit is $\tau = L/R$. The final value of the

Response is $iL(t \rightarrow \infty)$ when the switch is closed and circuit has reached a DC steady state condition. Replacing the inductor with a short circuit, we find $iL(t \rightarrow \infty) = i_s = V_s / R$. Substituting in the response formula above, we get

$$iL(t) = iL(\infty) + [iL(t_0^+) - iL(\infty)] e^{-(t-t_0)/T} \quad t \geq t_0$$

The Natural and Step Response of a Series RLC Circuit

The procedures for finding the natural or step responses of a series RLC circuit are the same as those used to find the natural or step responses of a parallel RLC circuit, because both circuits are described by differential equations that have the same form. We begin by summing the voltages around the closed path in the circuit shown in Figure 5.4 Thus

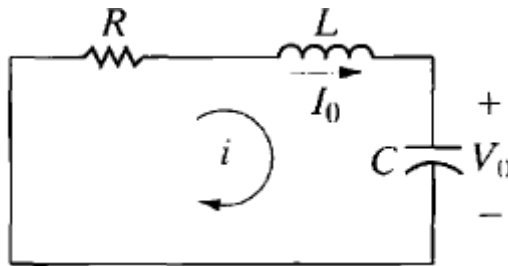

Figure 5.4 A circuit used to illustrate the natural response of a series RLC circuit.

$$Ri + L \frac{di}{dt} + \frac{1}{C} \int_0^t i d\tau + V_0 = 0. \quad \dots\dots\dots(5.1)$$

We now differentiate Eq 4.1 once with respect to t to get

$$R \frac{di}{dt} + L \frac{d^2i}{dt^2} + \frac{i}{C} = 0. \quad \dots\dots\dots(5.2)$$

which we can rearrange as

$$\frac{d^2i}{dt^2} + \frac{R}{L} \frac{di}{dt} + \frac{i}{LC} = 0. \quad \dots\dots\dots(5.3)$$

From Eq. 5.3, the characteristic equation for the series RLC circuit is

$$s^2 + \frac{R}{L}s + \frac{1}{LC} = 0. \quad \dots\dots\dots(5.4)$$

The roots of the characteristic equation are

$$s_{1,2} = -\frac{R}{2L} \pm \sqrt{\left(\frac{R}{2L}\right)^2 - \frac{1}{LC}}, \quad \dots\dots\dots(5.5)$$

Or

$$s_{1,2} = -\alpha \pm \sqrt{\alpha^2 - \omega_0^2}. \quad \dots\dots\dots(5.6)$$

The neper frequency (α) for the series RLC circuit is

$$\alpha = \frac{R}{2L} \text{ rad/s}, \dots\dots\dots(5.7)$$

and the expression for the resonant radian frequency is

$$\omega_0 = \frac{1}{\sqrt{LC}} \text{ rad/s}. \dots\dots\dots(5.8)$$

Note that the equation for neper frequency of the series RLC circuit differs from that of the parallel RLC circuit, but the equations for resonant and damped radian frequencies are the same.

The current response will be overdamped, underdamped, or critically damped according to whether $\omega^2 < \alpha^2$, $\omega^2 > \alpha^2$, or $\omega^2 = \alpha^2$, respectively.

Thus the three possible solutions for the current are as follows:

$$\begin{aligned} i(t) &= A_1 e^{s_1 t} + A_2 e^{s_2 t} \text{ (overdamped),} \\ i(t) &= B_1 e^{-\alpha t} \cos \omega_d t + B_2 e^{-\alpha t} \sin \omega_d t \text{ (underdamped),} \\ i(t) &= D_1 t e^{-\alpha t} + D_2 e^{-\alpha t} \text{ (critically damped).} \end{aligned} \dots\dots\dots(5.9)$$

When you have obtained the natural current response, you can find the natural voltage response across any circuit element. For convenience, we assume that zero energy is stored in the circuit at the instant the switch is closed.

Applying Kirchhoff's voltage law to the circuit shown in Figure 4.5 gives

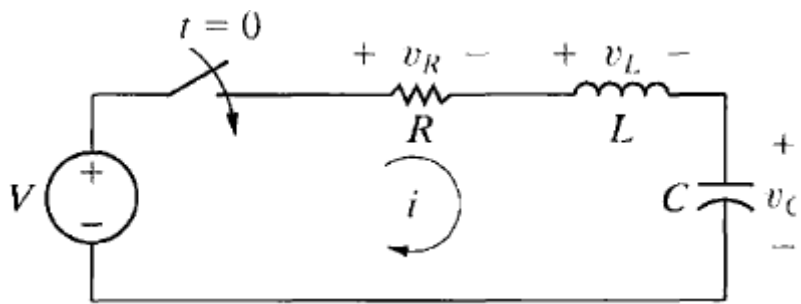

Figure 5.5: A circuit used to illustrate the step response of a series RLC circuit

$$V = Ri + L \frac{di}{dt} + v_C \dots\dots\dots(5.10)$$

The current (i) is related to the capacitor voltage (v_C) by the expression

$$i = C \frac{dv_C}{dt} \dots\dots\dots(5.11)$$

from which

$$\frac{di}{dt} = C \frac{d^2v_C}{dt^2} \dots\dots\dots(5.12)$$

Substitute Eqs. 5.11 and 5.12 into Eq. 5.10 and write the resulting expression as

$$\frac{d^2v_C}{dt^2} + \frac{R}{L} \frac{dv_C}{dt} + \frac{v_C}{LC} = \frac{V}{LC} \dots\dots\dots(5.13)$$

The three possible solutions for v_C are as follows:

$$v_C = V_f + A'_1 e^{s_1 t} + A'_2 e^{s_2 t} \text{ (overdamped),}$$

$$v_C = V_f + B'_1 e^{-\alpha t} \cos \omega_d t + B'_2 e^{-\alpha t} \sin \omega_d t \text{ (underdamped),}$$

$$v_C = V_f + D'_1 t e^{-\alpha t} + D'_2 e^{-\alpha t} \text{ (critically damped),}$$

where V_f is the final value of v_C . Hence, from the circuit shown in Figure 5.5, the final value of v_C is the dc source voltage V

Note: Study the Natural and Step Response of a parallel RLC Circuit

➤ **Prelab**

**** (Refer to procedure section for circuits figures)**

When simulating the circuits in all following parts, use a (V_{Pulse}) source from PSPICE library as the input voltage source, and connect a 50Ω resistance in series with source (output resistance of the source), an example of the settings of the source are as shown below.

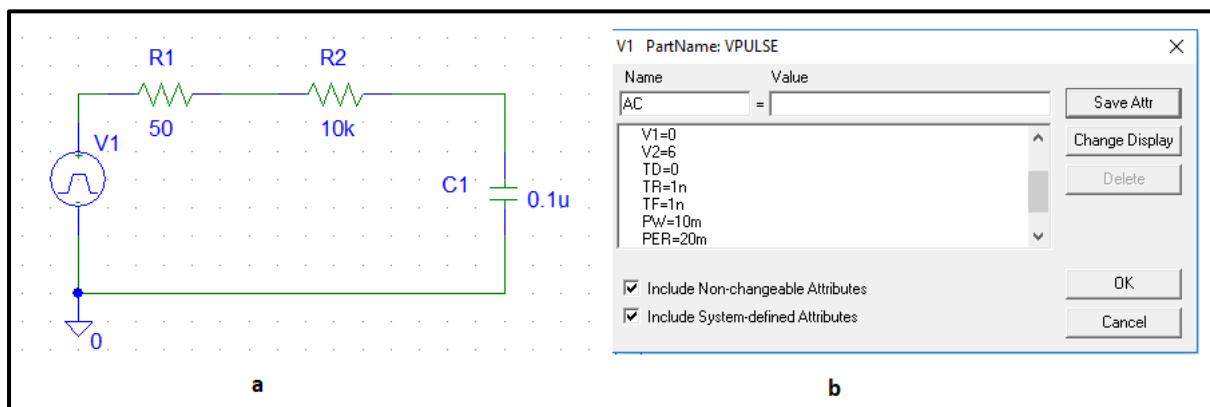

Figure 5.6: Simulation example and details.

Part A: Step response of First-order RC circuit

For the circuit of Figure 5.8:

1. Calculate $V_C(t)$ using the general solution formula, show calculation of time constant (τ).
2. Use PSPICE to do transient analysis of the circuit. **Show $V_C(t)$ and use cursors to measure time constant (τ).**
3. For the same circuit show $V_R(t)$ using a **differential voltage marker**, and use **cursors to measure time constant (τ).**

Part B: Step response of First-order RL circuit

For the circuit of Figure 5.10:

1. Calculate $V_L(t)$ using the general solution formula, show calculation of time constant (τ).
2. Use PSPICE to do transient analysis of the circuit. **Show $V_L(t)$ and use cursors to measure time constant (τ).**
3. For the same circuit show $V_R(t)$ using a **differential voltage marker**, and use **cursors to measure time constant (τ).**

Part C: Step response of second-order Series RLC circuit

For the circuit of Figure 5.12:

1. For $R = 10 \text{ k}\Omega$, calculate the roots of the characteristic equation and write an expression for $V_C(t)$. Use PSPICE to do transient analysis of the circuit, and show $V_C(t)$.
2. Calculate the critical resistance R_C that will result in equal roots ($S_1 = S_2 = -\alpha$) and write an expression for $V_C(t)$. Use PSPICE to do transient analysis of the circuit and show $V_C(t)$.
3. For $R = 500 \text{ }\Omega$, calculate the roots of the characteristic equation, **showing the value of α and ω_d** and write an expression for $V_C(t)$. Use PSPICE to do transient analysis of the circuit, show $V_C(t)$, and measure **α and ω_d using cursors as shown in figure 5.7.**

Part D: Step response of second-order parallel RLC circuit

For the circuit of Figure 5.13:

1. For $R = 4 \text{ k}\Omega$, calculate the roots of the characteristic equation **showing the value of α and ω_d** . Write an expression of $V_C(t)$. Use PSPICE to do transient analysis of the circuit, show $V_C(t)$, and measure **α and ω_d using cursors as shown in figure 5.7.**

- Calculate the critical resistance R_C that will result in equal roots ($S_1 = S_2 = -\alpha$) and write an expression for $V_C(t)$. Use PSPICE to do transient analysis of the circuit and show $V_C(t)$.
- For $R = 150 \Omega$, calculate the roots of the characteristic equation and write an expression for $V_C(t)$. Use PSPICE to do transient analysis of the circuit, and show $V_C(t)$.

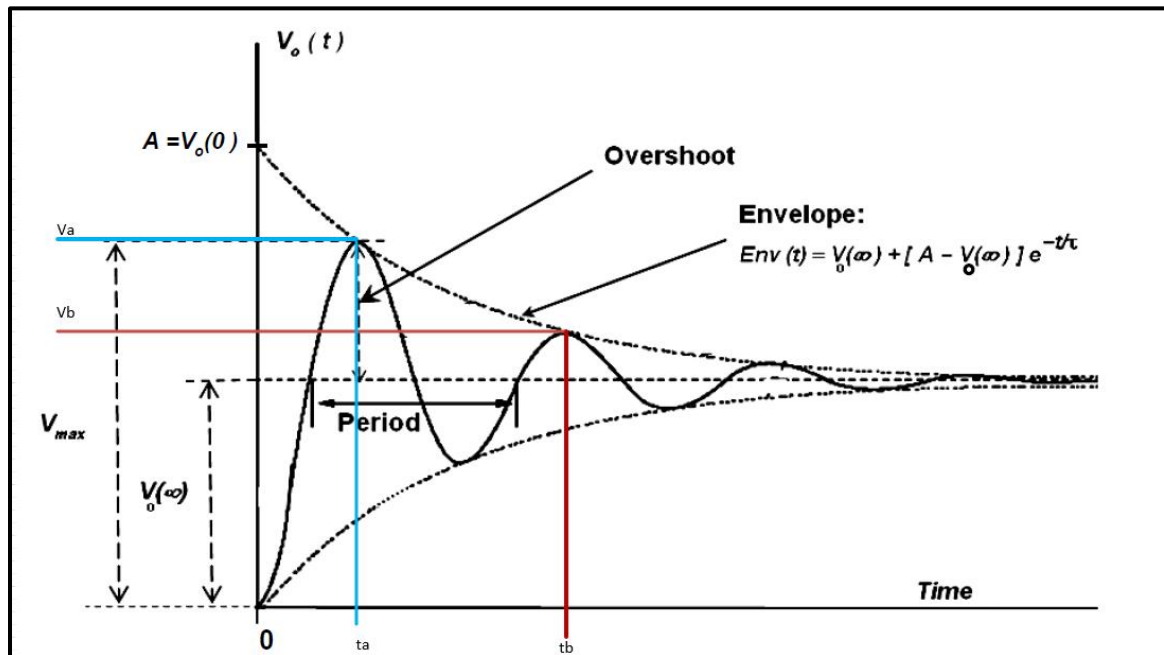

Figure 5.7: Example of calculating α and ω_d of underdamped response

Decay time constant $\tau = \frac{t_b - t_a}{\ln\left(\frac{V_a - V_o(\infty)}{V_b - V_o(\infty)}\right)}$ (5.14)

Damping Coefficient $\alpha = \frac{1}{\tau}$ (5.15)

Damped radian frequency $\omega_d = \frac{2\pi}{t_b - t_a}$ (5.16)

➤ Procedure

Part A: Step response of First-order RC circuit

- Connect the circuit shown in Figure 5.8, with the function generator set to produce a square wave of: $V_{in} = 6 V_{PP}$, $f = 50 \text{ Hz}$, and DC offset 3 V.

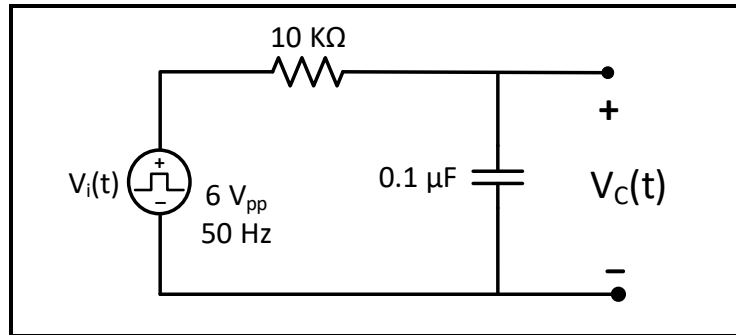

Figure 5.8

2. Measure the actual value of the $10\text{ k}\Omega$ resistor, record result in Table 4.1.
3. Set the oscilloscope to display the waveform $V_C(t)$ produced by this circuit.
4. Estimate the value of τ_c with the help of cursors on the screen of the scope, **take a picture of the waveform (with the value of τ_c shown) to be included in lab report.**

Question 1: Use the computed value of τ_c in step 4, and the **actual value** of your resistor plus the **output resistance** of the function generator to compute the value of the capacitance C ($\tau_c = RC$). The result should equal $0.1\text{ }\mu\text{F} \pm 20\%$.

5. **Repeat steps 1-4 for the circuit of Figure 5.9**, but this time showing $V_R(t)$ instead of $V_C(t)$, and estimating the value of τ_R .

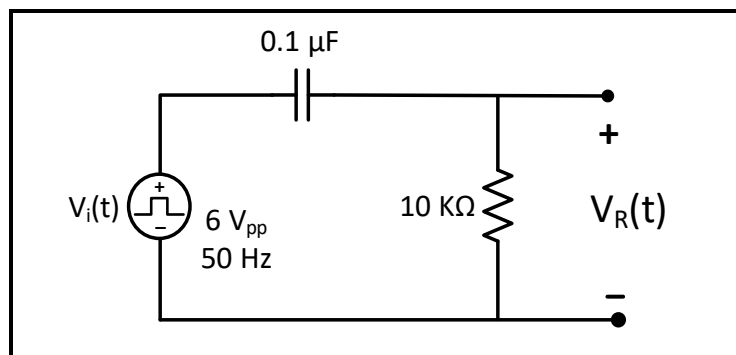

Figure 5.9

Question 2: In your report discuss the behavior of the graphs of $V_C(t)$ and $V_R(t)$, also compare the experimental values of time constant with the values calculated in prelab.

Part B: Step response of first-order RL circuit

1. Connect the circuit shown in Figure 5.10, with the function generator set to produce a square wave of: $V_{in} = 6\text{ V}_{pp}$, $f = 50\text{ Hz}$, and DC offset 3 V .
2. Measure the DC resistance of the inductor, and the actual value of the $1\text{ k}\Omega$ resistor using DMM, record result in Table 5.2.

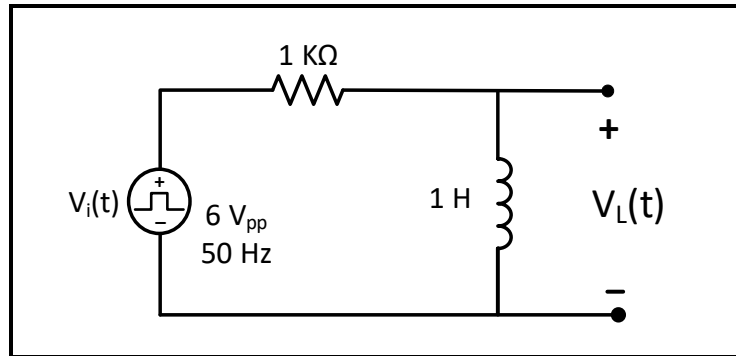

Figure 5.10

3. Set the oscilloscope to display the waveform $V_L(t)$ produced by this circuit.
4. Estimate the value of τ_L with the help of cursors on the screen of the scope, **take a picture of the waveform (with the value of τ_L shown) to be included in lab report.**

Question 3: Use the computed value of τ_L in step 4, and the **actual value** of your resistor plus the output resistance of the function generator plus the resistance of the inductor to compute the value of the Inductance L ($\tau_L = L/R$). The result should equal $1\text{H} \pm 20\%$.

5. **Repeat steps 1-4 for the circuit of Figure 5.11**, but this time showing $V_R(t)$ instead of $V_L(t)$, and estimating the value of τ_R .

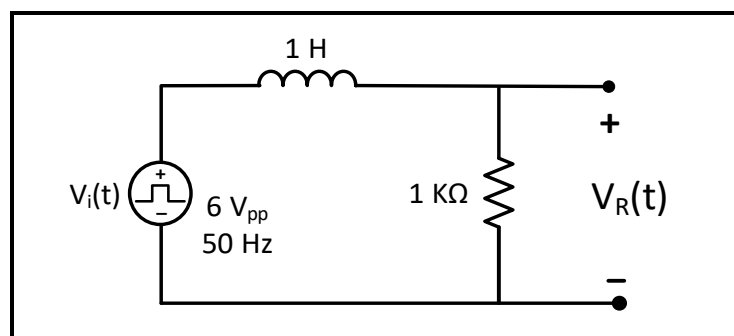

Figure 5.11

Question 4: In your report discuss the behavior of the graphs of $V_L(t)$ and $V_R(t)$, also compare the experimental values of time constant with the values calculated in prelab.

Part C: Step response of second-order Series RLC circuit

1. Connect the circuit shown in Figure 5.12, with the function generator set to produce a square wave of: 3V_{PP} , $f = 100\text{Hz}$, and DC offset 1.5V (**Use decade box for R**)

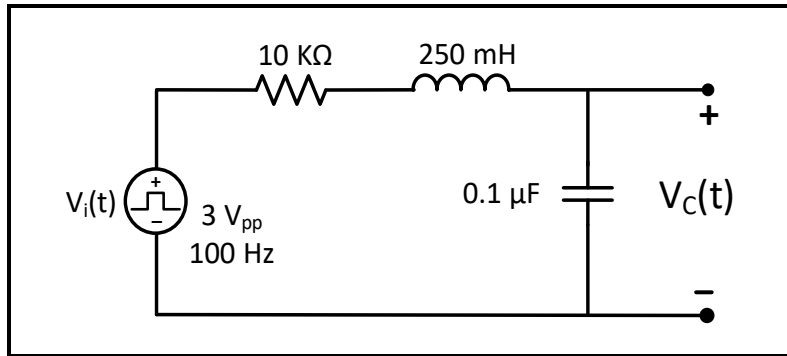

Figure 5.12

2. Measure the DC resistance of the inductor using DMM.
3. Connect CH2 of the oscilloscope across the capacitor.
4. Adjust the variable resistor over its entire range (10 k Ω to 1 k Ω) and note how the output waveform $V_C(t)$ varies.
5. Consider the following cases:

Case A: Over damped response

1. Set the variable resistor to 10 k Ω .
2. Take a picture of the resulting waveform, **to be included in lab report.**

Case B: Critically damped response

1. Set the variable resistor to the critical resistance ($R_{critical}$) found in the prelab.
2. Take a picture of the resulting waveform $V_C(t)$, **to be included in lab report.**

Question 5: Discuss the difference between the over and critical damped response as seen in the graphs

Case C: Under damped response

1. Set the variable resistor so that the total circuit resistance is equal to 500 Ω .
Notice that the total resistance of the circuit is the sum of: the value of the variable resistor, the output resistance of the function generator, and the parasitic resistance of the inductor.
2. Use cursors to find the values of V_a , t_a , V_b , t_b , and $V(\infty)$, as shown in figure 5.7, record results in Table 5.3.
3. Take a picture of $V_c(t)$ (with the value of cursors shown), **to be included in lab report.**

Question 6: Using measured values in step 2 of case (c), calculate decay-envelope time constant (τ), the damping coefficient (α), and damped frequency (ω_d), compare these values with theoretical values calculated in prelab.

Part D: Step response of second-order parallel RLC circuit

1. Connect the circuit in Figure 5.13, keeping the previous setting of the function generator (Square wave output, $3 V_{pp}$, DC offset 1.5 V, $f = 100$ Hz), (Use decade box for R).

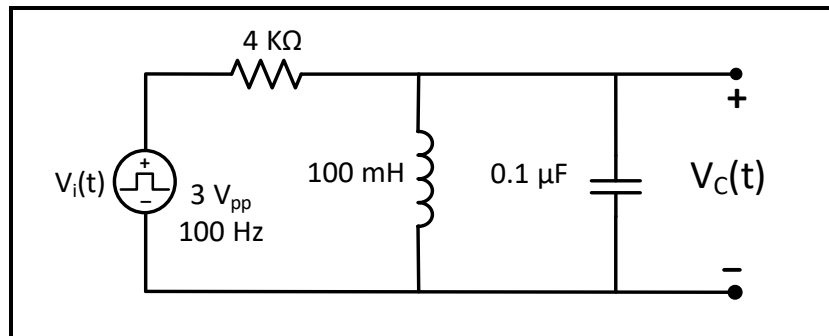

Figure 5.13

2. Measure the DC resistance of the inductor using DMM.
3. Connect CH2 of the oscilloscope across the capacitor.
4. Adjust the variable resistor over its entire range ($4 k\Omega$ to 100Ω) and note how the output waveform $V_C(t)$ varies.
5. Consider the following cases:

Case A: Under damped response

1. Set the variable resistor so that the total circuit resistance is equal to $4 k\Omega$.
Notice that the total resistance of the circuit is the sum of the value of the variable resistor, the output resistance of the function generator and the parasitic resistance of the inductor.
2. Use cursors to find the values of V_a , t_a , V_b , t_b , and $V(\infty)$, as shown in figure 5.7, record results in Table 5.4.
3. Take a picture of $V_C(t)$ (with the value of cursors shown), **to be included in lab report.**

Question 7: Using measured values in step 2 of case (a), calculate decay-envelope time constant (τ), the damping coefficient (α), and damped frequency (ω_d), compare these values with theoretical values calculated in prelab.

Case B: Critically damped response

1. Set the variable resistor to the critical resistance $R_{critical}$ found in the prelab.
2. Take a picture of the resulting waveform $V_C(t)$, **to be included in lab report.**

Case C: Over damped response

1. Set the variable resistor to 150Ω .
2. Take a picture of $V_C(t)$ as displayed by the oscilloscope, **to be included in lab report.**

Question 8: Discuss the difference between the over and critical damped response as seen in the graphs

Before Leaving the Laboratory

Be sure the following is completed before you leave the laboratory.

- (d) Check to be sure that you have all the required measured values.
- (e) Have the laboratory instructor check your laboratory readings.
- (f) Restore your laboratory station (equipment and chairs) to the condition they were in when you arrived.

Thank you for your cooperation.

Experiment 6

Flux Produced by Field Coils

➤ **Objectives:**

The aim of this experiment is to recognize some of basic information about the flux produced by field coils, and to explore the operation of transformer in circuits.

➤ **Equipment Required:**

1. Power supply
2. Function generator.
3. Digital Multimeter
4. Oscilloscope
5. Board, wires, capacitors, and resistances.
6. Dissectable Transformer and compass.

➤ **Introduction:**

The experiment shows that when current flows in a conductor, a flux is produced in the direction as given by the right-hand grip rule, the thumb represents the direction of the current and the fingers represents the direction of the flux surrounding the conductor. When a conductor is wound on a core made from a ferromagnetic material, this gives a low reluctance magnetic circuit with negligible flux leakage. The strength of magnetic field is measured as flux density **B**:

$$B = \phi / A,$$

Where:

Φ = flux in a section of the magnetic circuit.

A= Area of the section.

When the flux through a coil increases or decreases, an emf is induced in the coil, which is proportional to the rate of change of flux. The magnitude of this emf is

$$E = N \frac{d\phi}{dt} \quad [\text{Volts}]$$

where $d\Phi$ = change of flux [weber], dt = change in time [second], N = no. of turns in coil, E = average emf [volt]

Due to the residual magnetism in the steel lamination of the conductor's core, the coil still produces a weak magnetic field if the supply is switched off from the coil.

A change in the value of current flowing in one coil causes a corresponding change in the flux linking the second coil, An e.m.f is therefore induced in the other coil, as it occurs in the transformer.

The current drawn by primary winding from the ac supply produces an alternating flux, which links all the coils, which embrace the core. The voltage induced in the secondary can be measured directly but a voltage will also be induced in the primary winding since its turns are linked by the same flux. The voltage produced in the secondary windings depends on the ratio of the primary to secondary turns and magnetic flux, which links the two windings.

The induced voltage in the primary is referred to as the back e.m.f it is almost equal in value to the a.c supply voltage and will always act in opposition to it. So, tending to reduce the current taken from the supply. The voltage in each turn of both the primary and the secondary windings will be the same, consequently the value of the voltage induced in the secondary will depend on the ratio of the number of turns in the secondary to those in the primary.

When there are more secondary than primary turns the primary is said, "step up" and the secondary voltage is higher than that on the primary. With fewer secondary than primary turns the transformer is "step down" and output voltage is lower than the supply. For the same number of turns for each winding, the transformer is "one to one".

The voltage induced by the alternating flux in any coil wound round the core may be expressed as a given value of volts per turn.

Let number of turns in primary = N_1 , and let number of turns in secondary N_2

Voltage per turn = k

Then primary voltage, $V_1 = k N_1$, and the secondary voltage, $V_2 = k N_2$

$$V_1/V_2 = K_1 N_1 / K_2 N_2 = N_1/N_2 \dots\dots\dots(1)$$

Taking k as constant

Load current in the secondary will produce a flux, which tends to reduce the main flux. This leads to an increase in primary current sufficient to maintain the flux in the core at its original value. To do this, the (additional current) x (number of turns in the primary) will become equal to the load (load current) x (number of turns in the secondary). This may be expressed as primary ampere-turns = secondary ampere-turns.

$$I_1 N_1 = I_2 N_2$$

$$\text{And, } I_1/I_2 = N_2/N_1 \dots\dots\dots(2)$$

Combining equations (1) and (2)

$$V_1/V_2 = I_2/I_1 \text{ for ideal transformer.}$$

➤ **Procedure**

Part A: ELECTRO-MAGNETIC CIRCUITS

1. Make the connection shown in Figure 6.1:
 - a. Stand the coil vertically in front of the compass.

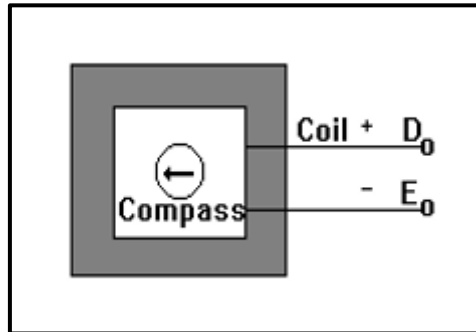

Figure 6.1

- b. Set the output of the power supply to 6 V, then turn on the power supply.
 - c. Note that the pole of the compass needle is deflected toward the center of the coil.
Why?

2. Make the connection as shown in Figure 6.2:

- a. Terminals F and E are connected together, and D and G are connected to the power supply.

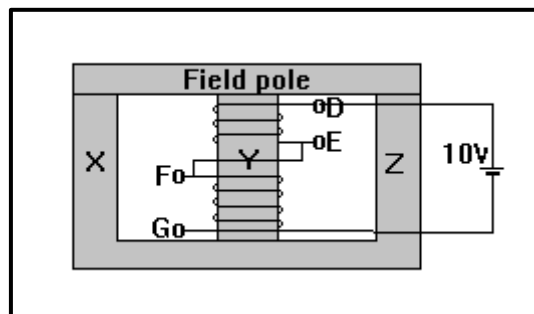

Figure 6.2

- b. Set the output of the DC power supply to 10 volts, then turn on the power.
 - c. Use a compass to identify the field poles, and the direction of flux at the ends (X, Y, Z) with field pole fitted.
 - d. Try to remove the field pole, **what happens? Why?**
 - e. Switch off the dc supply, try to remove the field pole, **what happens? Why?**
3. Reverse the connection of the coils in figure 6.2 and repeat steps 2: (a – e). **What do you find?**

4. Make the connection as shown in Figure 6.3
 - a. Set the output of the DC power supply to 10 volts.

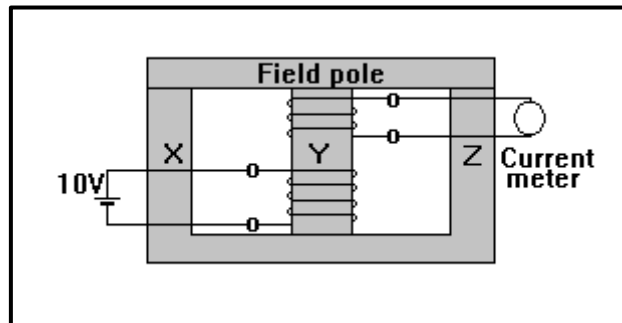

Figure 6.3

- b. Set the digital multi-meter to DC current range, then close the field pole to attach the ends X, Y, and Z.
 - c. Switch the 10 V DC supply on and off, there will be a change in the meter reading at each operation. **Discuss why?**
5. Remove the field pole and repeat step 4: (a-c), **what do you notice? Comment?**

Part B: Transformer

B.1: Phase Relationship between Transformer Primary and Secondary Voltages

1. Connect the circuit of Figure 6.4, with $V_{in}(t)$ as a sinusoidal voltage $8 V_{PP}$ and $f = 5$ kHz.

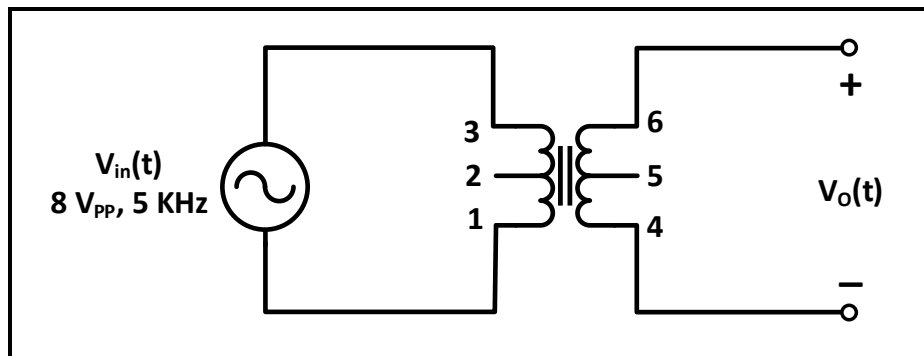

Figure 6.4

- a. Connect CH1 of oscilloscope to the input and CH2 to the output of transformer.
 - b. From the oscilloscope observe the RMS value of primary and the secondary voltages, and observe the phase relationship between the two voltages, record results in Table 6.1

Question 1: Calculate the turns ratio $a = N_p/N_s = V_p/V_s$. Record results in Table 6.1.

B.2: Voltage, Current, Turns Ratio, and Impedance transformation:

1. Connect the circuit of Figure 6.5, set $V_{in}(t)$ to sinusoidal voltage with $6 V_{PP}$ and $f = 5$ kHz.

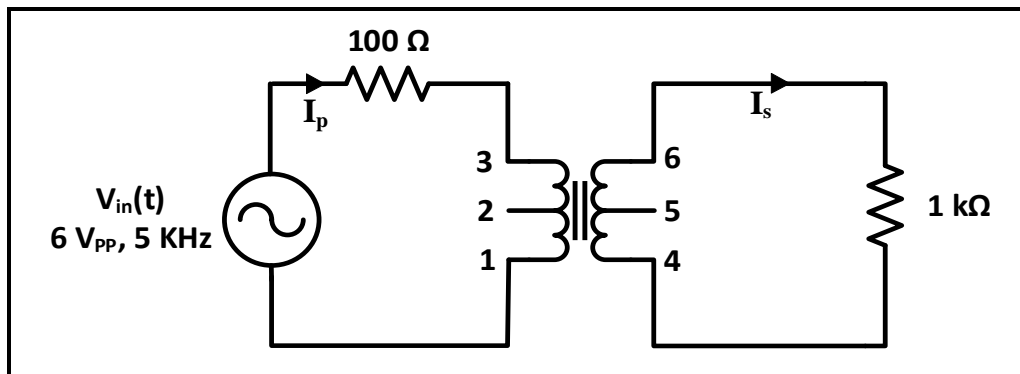

Figure 6.5

- a. Measure the primary and the secondary voltages and currents (V_P , V_S , I_P , I_S), **using DMM**, record results in Table 6.2.

Question 2: Calculate the turns ratio a using ($a = V_P/V_S$), record results in Table 6.3, is this a step-up or step-down transformer?

Question 3: Calculate the magnitude of the reflected impedance Z_P theoretically, record results in Table 6.3.

Question 4: Calculate the magnitude of the reflected impedance ($Z_P = V_{in} / I_P$) using the measurements of step (a), record results in Table 6.3 and compare with theoretical calculation in previous question.

Question 5: Using the measured values of I_P , V_P , I_S , V_S calculate the apparent power of the primary and secondary sides of the transformer, record results in Table 6.3. Are those equal?

2. Connect the circuit of Figure 6.6, set $V_{in}(t)$ to sinusoidal voltage with $4 V_{PP}$ and $f = 5$ kHz

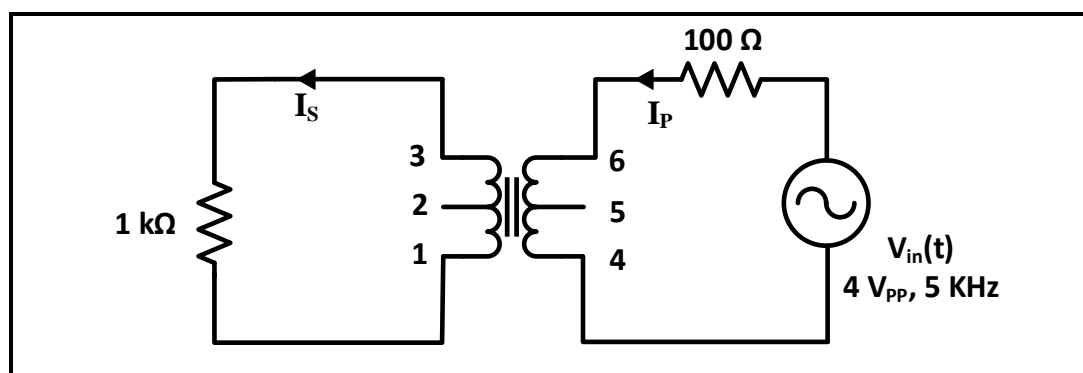

Figure 6.6

- a. Measure V_P , V_S , I_P , and I_S , using DMM, record results in Table 6.4.

Question 6: Calculate the turn's ratio using ($a = I_S/I_P$) record results in Table 6.4. Is this value equal to the calculated value in question 2? Is the transformer being used as step-up or step-down transformer?

Experiment 7

Impedance and Sinusoidal Steady State

➤ **Objectives:**

1. Examine the frequency dependent behavior of impedance.
2. Examine the sinusoidal steady-state response of RL, and RC circuits.
3. Measuring of self-inductance and capacitance

➤ **Equipment Required:**

1. Function generator
2. Digital Multimeter.
3. Oscilloscope
4. Board, wires, capacitors, inductor box, and resistances.
5. DC Power Supply.

➤ **Introduction:**

The general equation for a sinusoidal source is

$$v = V_m \cos(\omega t + \phi) \text{ (voltage source)}$$

$$i = I_m \cos(\omega t + \phi) \text{ (current source)}$$

Where V_m (or I_m) is the maximum amplitude, ω is the frequency, and ϕ is the phase angle.

The frequency, ω , of a sinusoidal response is the same as the frequency of the sinusoidal source driving the circuit. The amplitude and phase angle of the response are usually different from those of the source.

The best way to find the steady-state voltages and currents in a circuit driven by sinusoidal sources is to perform the analysis in the frequency domain. The following mathematical transforms allow us to move between the time and frequency domains.

The phasor transform (from the time domain to the frequency domain):

$$V = V_m e^{j\phi} = \mathcal{P}\{V_m \cos(\omega t + \phi)\}.$$

The inverse phasor transform (from the frequency domain to the time domain):

$$\mathcal{P}^{-1}\{V_m e^{j\phi}\} = \Re\{V_m e^{j\phi} e^{j\omega t}\}$$

The V-I Relationship for a Resistor:

From Ohm's law, if the current in a resistor varies sinusoidally with time that is, if $i = I_m \cos(\omega t + \theta_i)$ the voltage at the terminals of the resistor, as shown in Figure 7.1 is

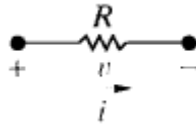

Figure 7.1: A resistive element carrying a sinusoidal current

$$v = R [I_m \cos(\omega t + \theta_i)]$$

$$v = RI_m [\cos(\omega t + \theta_i)]$$

Where I_m is the maximum amplitude of the current in amperes and θ_i is the phase angle of the current. The phasor transform of this voltage is

$$\mathbf{V} = RI_m e^{j\theta_i} = RI_m \angle \theta_i.$$

But $I_m \angle \theta_i$ is the phasor representation of the sinusoidal current, so we can write as $\mathbf{V} = RI$ which states that the phasor voltage at the terminals of a resistor is simply the resistance times the phasor current. There is no phase shift between the current and voltage. Figure 7.2 depicts this phase relationship, where the phase angle of both the voltage and the current waveforms is 60° . The signals are said to be in phase because they both reach corresponding values on their respective curves at the same time.

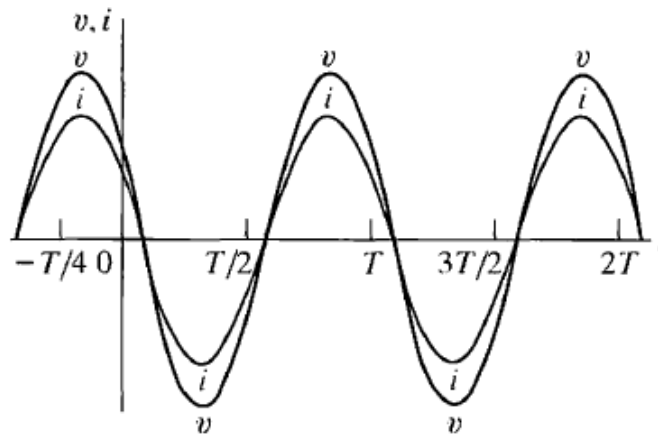

Figure 7.2: Voltage and current at the terminals of a resistor are in phase.

The V-I Relationship for an Inductor:

We derive the relationship between the phasor current and phasor voltage at the terminals of an inductor by assuming a sinusoidal current and using $L di/dt$ to establish the corresponding voltage. Thus, for $i = I_m \cos(\omega t + \theta_i)$, the expression for the voltage is

$$v = L di/dt = -\omega L I_m \sin(\omega t + \theta_i).$$

The phasor representation of the voltage given: $\mathbf{v} = j\omega L \mathbf{I}$

The equation states that the phasor voltage at the terminals of an inductor equals $j\omega L$ times the phasor current. Figure 7.3 shows the frequency domain equivalent circuit for the inductor.

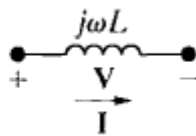

Figure 7.3: The frequency-domain equivalent circuit for an inductor

$$v = (\omega L \angle 90^\circ) I_m \angle \theta_i$$

$$v = \omega L I_m \angle (90^\circ + \theta_i)$$

Which indicates that the voltage and current are out of phase by exactly 90° . In particular, the voltage leads the current by 90° , or, equivalently, the current lags behind the voltage by 90° .

Figure 7.4 illustrates this concept of voltage leading current or current lagging voltage.

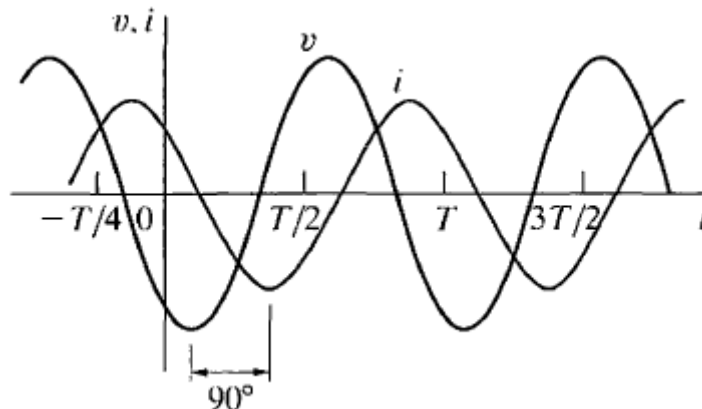

Figure 7.4: A plot showing the phase relationship between the current and voltage at the terminals of an inductor ($\theta_i = 60^\circ$).

The V-I Relationship for a Capacitor:

The relationship between the phasor current and phasor voltage at the terminals of a capacitor $i = c \, dv/dt$, and assume that

$$v = V_m \cos(\omega t + \theta_v), \text{ then}$$

$$I = j\omega C v$$

The voltage as a function of the current

$$V = 1/j\omega c I$$

The equivalent circuit for the capacitor in the phasor domain is as shown in Figure 7.5

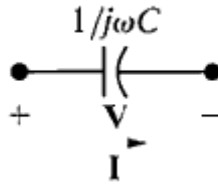

Figure 7.5: The frequency domain equivalent circuit of a capacitor.

The voltage across the terminals of a capacitor lags behind the current by exactly 90° .

$$V = 1/\omega C \angle -90^\circ I_m \angle \theta_i$$

$$V = I_m / \omega C \angle (\theta_i - 90^\circ)$$

The current leads the voltage by 90° . Figure 7.6 shows the phase relationship between the current and voltage at the terminals of a capacitor.

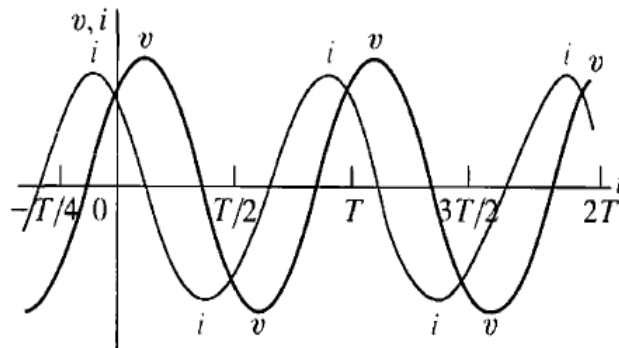

Figure 7.6: A plot showing the phase relationship between the current and voltage at the terminals of a capacitor ($\theta_i = 60^\circ$).

Impedance and Reactance:

$$V = ZI$$

Where Z represents the impedance of the circuit element. Solving for Z in equation, you can see that impedance is the ratio of a circuit element's voltage phasor to its current phasor. Thus the impedance of a resistor is R , the impedance of an inductor is $j\omega L$, the impedance of mutual inductance is $j\omega M$, and the impedance of a capacitor is $1/\omega C$. In all cases, impedance is measured in ohms.

Note that, although impedance is a complex number, it is not a phasor. Remember, a phasor is a complex number that shows up as the coefficient of e^{jt} . Thus, although all phasors are complex numbers, not all complex numbers are phasors. Impedance in the frequency domain is the quantity analogous to resistance, inductance, and capacitance in the time domain. The imaginary part of the impedance is called reactance. The values of impedance and reactance for each of the component values are summarized in Table 7.1. And finally, a reminder. If the reference direction for the current in a passive circuit element is in the direction of the voltage

rise across the element, you must insert a minus sign into the equation that relates the voltage to the current.

TABLE 7.1: Impedance and Reactance Values

Circuit Element	Impedance	Reactance
Resistor	R	—
Inductor	$j\omega L$	ωL
Capacitor	$j(-1/\omega C)$	$-1/\omega C$

➤ **Prelab:**

➤ **Part A: Impedance Measurement**

1. For the circuits shown in Figures 7.7 - 7.10 **calculate the magnitude** of the impedances Z_R , Z_C , Z_L , and Z_{RC} respectively, for the following frequencies: 250, 500, 1000 and 2000 Hz.

➤ **Part B: Phase Measurement**

1. For the circuit shown in Figure 7.11:
 - a. Use PSPICE to do transient analysis of the circuit, show $V_{in}(t)$ and $V_R(t)$ on one plot (you may need to use different Y-axes).
 - b. Use cursors to measure the time difference between the peaks of the two signals, then use the following relationship to calculate the phase shift using the measured time $\{\Delta\theta = 360^\circ \times f \times \Delta t\}$.
2. Repeat the same procedure in step 1 above for the circuit shown in Figure 7.12.

➤ **Procedure**

➤ **Part A: Impedance Measurement**

1. Connect the circuit in Figure 7.7, set V_{in} to sinusoidal voltage at $8 V_{pp}$, $f = 250$ Hz

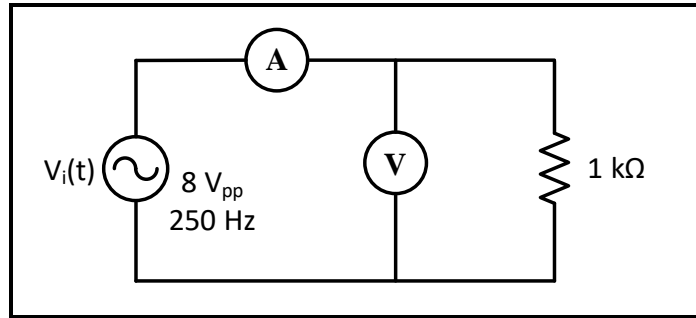

Figure 7.7

- a. Measure current and voltage of the resistor **using DMM**, record results in Table 7.1.
- b. Repeat step (a) for $f = 500$ Hz, 1000 Hz and 2000 Hz, record results in Table 7.1.

Question 1: Using measured values of $|I|$ and $|V|$ calculate $|Z_R|$ for each value of f recording results in Table 7.1. How does changing frequency affects the impedance Z_R ?

2. Connect the circuit in Figure 7.8, set V_{in} to sinusoidal voltage at $8 V_{pp}$, $f = 250$ Hz.

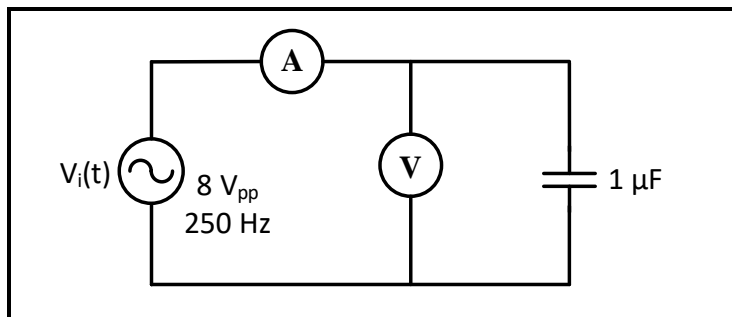

Figure 7.8

- a. Repeat steps (a) and (b) in (1) for the circuit in Figure 7.8 record results in Table 7.2.

Question 2: Using measured values of $|I|$ and $|V|$ calculate $|Z_C|$ for each value of f recording results in Table 7.2. How does changing frequency affects the impedance Z_C ?

3. Connect the circuit in Figure 7.9, set V_{in} to sinusoidal voltage at $8 V_{pp}$, $f = 250$ Hz.

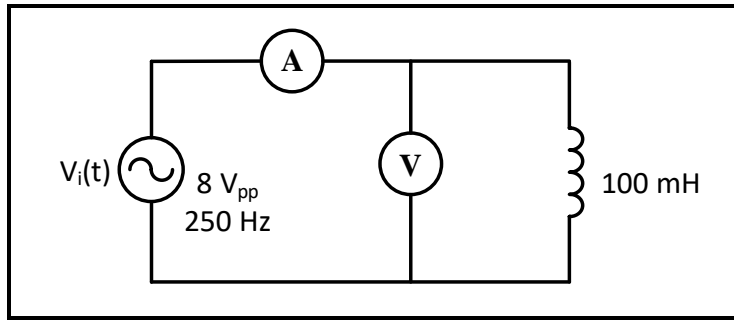

Figure 7.9

a. Repeat steps (a) and (b) in (1) for the circuit of Figure 7.9 record results in Table 7.3.

Question 3: Using measured values of $|I|$ and $|V|$ calculate $|Z_L|$ for each value of (f) recording results in Table 7.3. How does changing frequency affects the impedance Z_L ?

4. Connect the circuit in Figure 7.10, set V_{in} to sinusoidal voltage at $8 V_{PP}$, and $f = 250$ Hz.

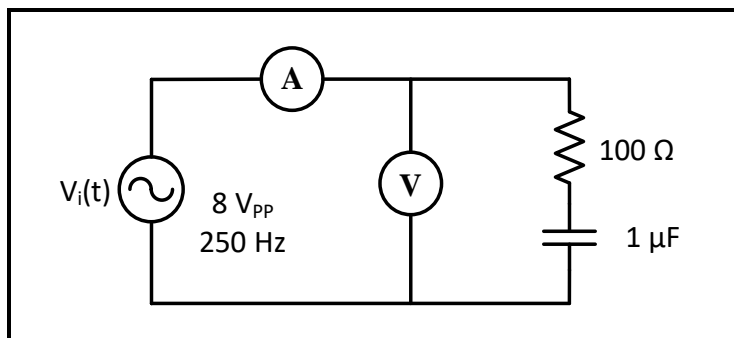

Figure 7.10

a. Repeat steps (a) and (b) in (1) for the circuit in Figure 6.10 record results in Table 7.4.

Question 4: Using measured values of $|I|$ and $|V|$ calculate $|Z_{RC}|$ for each value of (f) recording results in Table 7.4. How does changing frequency affects the impedance Z_{RC} compared to Z_C in step 2?

➤ **Part B: Phase shift measurement**

1. Connect the circuit in Figure 7.11, set V_{in} to sinusoidal voltage at $8 V_{PP}$ and $f = 50$ Hz.

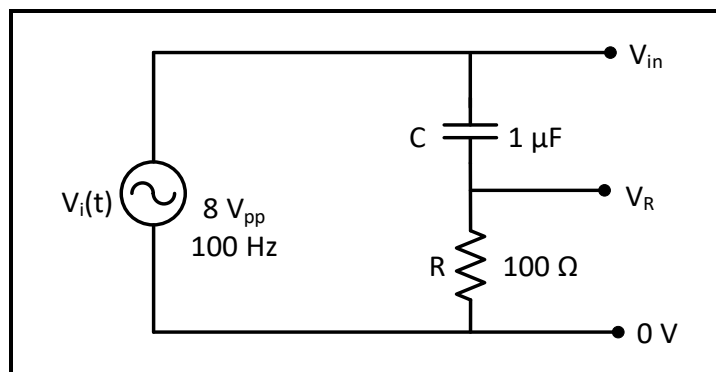

Figure 7.11

- a. Connect CH1 of oscilloscope across V_{in} and CH2 across V_R . Measure the time difference (Δt) between $V_{in}(t)$ and $V_R(t)$ using cursors, record result in Table 7.5, take a picture of the scope screen to be added to the report.

Note that V_R has the same waveform as the current in the circuit, and V_{in} will approximately equal $\approx V_C$ since Z_C is much higher than Z_R .

Question 5: Using measured value of (Δt) calculate the phase shift ($\Delta\theta$), record result in Table 7.5. If (V_{in}) represents (V_C), and (V_R) represents current (I_C), which one of the voltage and the current lags the other?

2. Connect the circuit in Figure 7.12, set V_{in} to sinusoidal voltage at $8 V_{pp}$ and $f = 1 \text{ KHz}$.

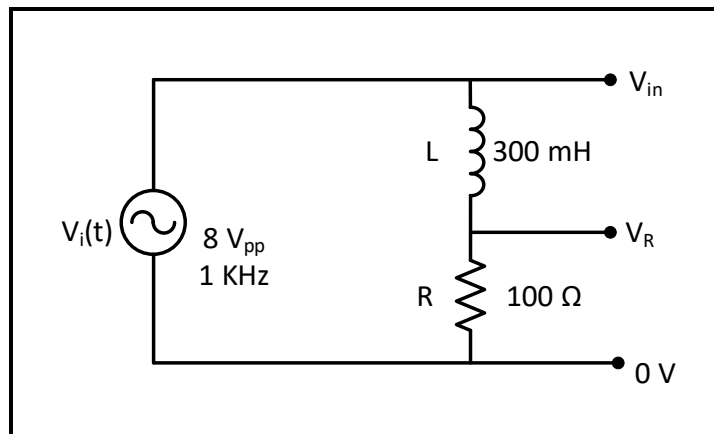

Figure 7.12

- a. Connect CH1 of oscilloscope across V_{in} and CH2 across V_R . Measure the time difference between $V_{in}(t)$ and $V_R(t)$ using cursors, record results in Table 7.6, take a picture of the scope screen to be added to the report.

Note that the voltage V_R has the same waveform as the current in the circuit, and V_{in} will approximately equal $\approx V_L$ since Z_L is much higher than Z_R .

Question 6: Using measured value of (Δt) calculate the phase shift ($\Delta\theta$), record result in Table 7.6. If (V_{in}) represents (V_L), and (V_R) represents current (I_L), which one of the voltage and the current lags the other?

➤ Part C: Inductance and Capacitance Measurement

1. Connect the circuit of Figure 7.13, set V_{in} to sinusoidal voltage at $6 V_{pp}$, and $f = 1 \text{ kHz}$.

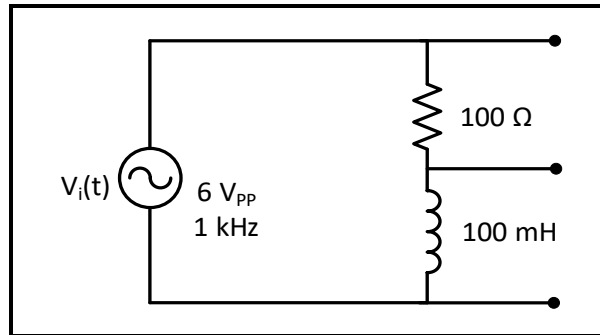

Figure 7.13

- a. Measure current in the circuit $|I|$, voltage across resistor $|V_R|$, and voltage across inductor $|V_L|$ using DMM, record results in Table 7.7.

Question 7: Using measured values of $|I|$ and $|V|$, calculate the self-inductance of the coil, record result in Table 7.7 and compare to theoretical value.

2. Connect the circuit of Figure 7.14, set V_{in} to sinusoidal voltage at $6 V_{PP}$, $f = 1 \text{ kHz}$.

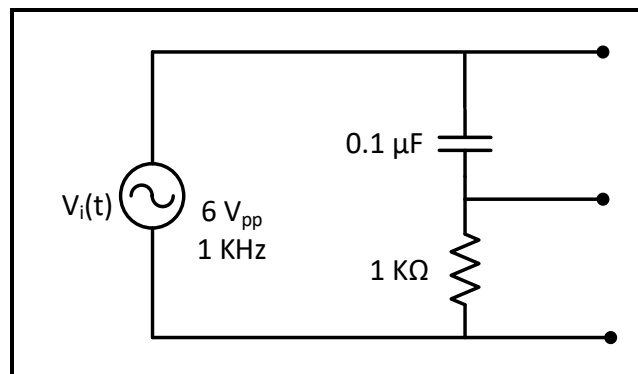

Figure 7.14

- a. Measure current in the circuit $|I|$, voltage across resistor $|V_R|$, and voltage across capacitor $|V_C|$ using DMM, record results in Table 7.8.

Question 8: Using measured values of $|I|$ and $|V|$ calculate the capacitance of the capacitor record results in Table 7.8 and compare to theoretical value.

Before Leaving the Laboratory

Be sure the following is completed before you leave the laboratory.

- (g) Check to be sure that you have all the required measured values.
- (h) Have the laboratory instructor check your laboratory readings.

- (i) Restore your laboratory station (equipment and chairs) to the condition they were in when you arrived.

Thank you for your cooperation.

Experiment 8

AC & DC Power Analysis and Design

➤ **Objectives:**

1. Examine AC and DC circuit power analysis and maximum power transfer design.

➤ **Equipment Required:**

1. Digital Multimeter.
2. Function Generator.
3. Oscilloscope.
4. Resistors.
5. Inductor 100mH.

➤ **Introduction:**

To understand power factor, we'll first start with the definition of some basic terms:

KW is Working Power (also called Actual Power or Active Power or Real Power).

It is the power that actually powers the equipment and performs useful work.

KVAR is Reactive Power.

It is the power that magnetic equipment (transformer, motor and relay) needs to produce the magnetizing flux.

KVA is Apparent Power

Power Factor (P.F.) is the ratio of Working Power to Apparent Power.

$$PF = KW / ((KW)^2 + (KVAR)^2)^{0.5} = P_{av} / P_a$$

$$PF = \cos (\theta_v - \phi_i)$$

The "Power Triangle" Figure 8.1 illustrates this relationship between KW, KVA, KVAR, and Power Factor:

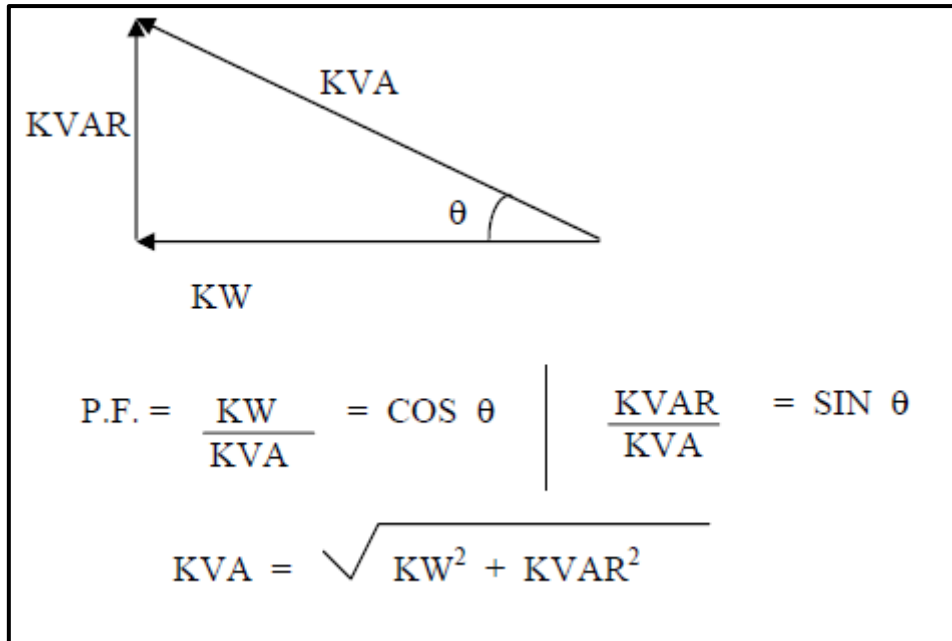

Figure 8.1

Note:

- KVAR would be very small.
- KW and KVA would be almost equal
- The angle θ (formed between KW and KVA) would approach zero
- Cosine θ would then approach one
- Power Factor would approach one

Since power factor is defined as the ratio of KW to KVA, we see that low power factor results when KW is small in relation to KVA. What causes a large KVAR in a system?

The answer is...inductive loads.

Inductive loads (which are sources of Reactive Power) include:

- Transformers
- Induction motors
- Induction generators (wind mill generators)
- High intensity discharge (HID) lighting

Power Factor correction:

You want to improve your power factor for several different reasons. Some of the benefits of improving your power factor include:

1. Lower utility fees
2. Increased system capacity and reduced system losses in your electrical system
3. Increased voltage level in your electrical system and cooler, more efficient motors

Thus, it comes as no surprise that one way to increase power factor is to add capacitors to the system. This and other ways of increasing power factor are listed below:

1. Installing capacitors (KVAR Generators) Minimizing operation of idling or lightly loaded motors.
2. Avoiding operation of equipment above its rated voltage.

The Maximum Power Transfer Theorem is not so much a means of analysis as it is an aid to system design. Simply stated, the maximum amount of power will be dissipated by a load resistance when that load resistance is equal to the Thevenin/Norton resistance of the network supplying the power. If the load resistance is lower or higher than the Thevenin/Norton resistance of the source network, its dissipated power will be less than the maximum.

Maximum power is transferred from the source to the load when the resistance of the circuit is equal to the resistance of the load.

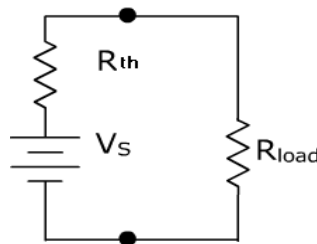

Figure 8.2: $R_{Load} = R_{Th}$

The efficiency factor is based on the percentage of total power generated by the source that is delivered to the load.

$$\text{Efficiency}(\%) = \frac{P_{out}}{P_{in}} \times 100$$

Maximum power is delivered to the load when $R_{load} = R_{int}$, therefore, the efficiency would be equal to 50 percent.

For the sinusoidal steady state:



Figure 8.3: Finding maximum average power transfer: (a) circuit with a load, (b) Thevenin equivalent

Consider the circuit in Figure 7.3, where an ac circuit is connected to a load Z_L and is represented by its Thevenin equivalent. The load is usually represented by an impedance, which may model an electric motor, an antenna, a TV, and so forth. In rectangular form, the Thevenin impedance Z_{TH} and the load impedance Z_L are

$$Z_{TH} = R_{TH} + jX_{TH}$$

$$Z_L = R_L + jX_L$$

The current through the load is

$$I = \frac{V_{TH}}{Z_{TH} + Z_L} = \frac{V_{TH}}{((R_{TH} + jX_{TH}) + (R_L + jX_L))}$$

The average power delivered to the load is

$$P = \frac{1}{2} |I|^2 R_L = \frac{V_{TH}}{Z_{TH} + Z_L} = \frac{|V_{TH}|^2 R_L / 2}{((R_{TH} + R_L)^2 + (X_{TH} + X_L)^2)}$$

Our objective is to adjust the load parameters R_L and X_L so that P is maximum. To do this we set $\partial P / \partial R_L$ and $\partial P / \partial X_L$ equal to zero. From the previous equation, we obtain Setting $\partial P / \partial X_L$ to zero gives $X_L = -X_{TH}$

and setting $\partial P / \partial R_L$ to zero results in $R_L = \sqrt{(R_{TH})^2 + (X_{TH} + X_L)^2}$

Combining the two previous equations leads to the conclusion that for maximum average power transfer, Z_L must be selected so that $X_L = -X_{TH}$ and $R_L = R_{TH}$

$$Z_L = R_L + jX_L = R_{TH} - jX_{TH} = Z_{TH}^*$$

For maximum average power transfer, the load impedance Z_L must be equal to the complex conjugate of the Thevenin impedance Z_{TH}

➤ **Prelab:**

1. Make a DC sweep for R_L in the circuit of Figure 8.5 to produce a plot of (P_{LOAD} vs. R_L) for the range of values of R_L shown in Table 8.2, use cursors to find the value of R_L that results in maximum power transfer to R_L .

2. For the circuit of Figure 8.6:

Note: Use **RMS** values for these calculations. All phase angles must be referenced to V_S whose angle is zero.

- Use phasor analysis to calculate V_L and I_L , assume the input voltage $V_{in} = 8 V_{PP} \angle 0^\circ$.
 - Calculate the complex power of the load” S_L .
 - Calculate the parallel capacitance needed to correct the load power factor to unity.
 - Use PSPICE to do transient analysis of the circuit in Figure 8.6, show $I(t)$ and $V_L(t)$ (indicated on circuit) on one graph, you will need different Y-axis, and measure the power factor (from the time difference between the two waveforms).
 - Repeat the previous step with the added capacitor to show power factor improvement.
3. For the circuit of Figure 8.8, design a load that is when connected to the output terminals of the circuit will extract maximum average power, then calculate magnitude of P_{Max} .

➤ **Procedure:**

➤ **Part A: DC power measurement**

1. Connect the circuit of Figure 8.4

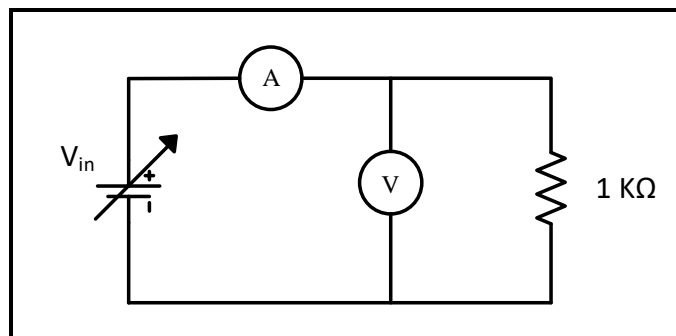

Figure 8.4

2. Measure the resistor current as input voltage is varied according to Table 8.1. Record results in the same table.

Question 1: Calculate the power of R using the data in Table 8.1. Record results in Table 8.1.

Question 2: Use excel to draw a graph of (power vs. current). Deduce the relationship between the power and the current through a resistor.

➤ **Part B: Maximum DC power transfer**

1. Connect the circuit of Figure 8.5, with the output of the power supply set to 15 V.

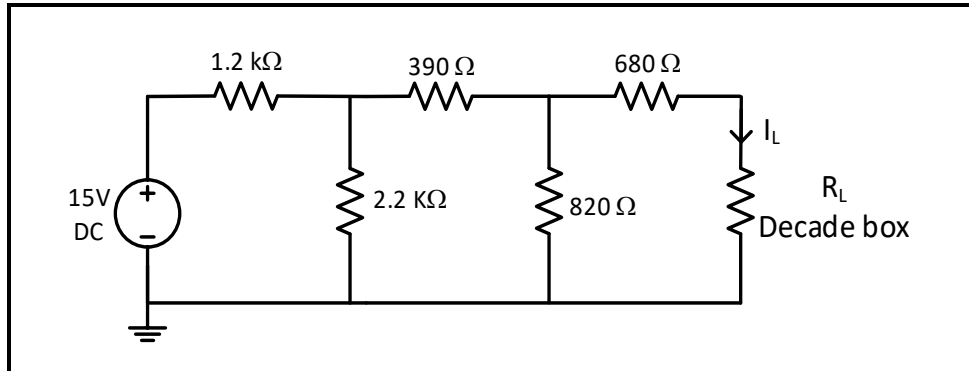

Figure 8.5

2. Measure the current I_L for each value of the load resistor R_L shown in Table 8.2, record results in the same table.
3. Measure the equivalent resistor to the left of variable resistor after killing the source, record result below Table 8.2.

Question 3: Calculate the power dissipated by R_L , record results in Table 8.2.

Question 4: Use excel to plot a graph of power dissipated by the load against corresponding value of load. From the graph determine the load resistance which dissipated maximum power, compare it with the value measured in step 3, and discuss the behavior of the graph.

➤ **Part C: Power factor measurement**

1. Connect the circuit of Figure 8.6, set the function generator to produce a sinusoidal voltage at 8 V_{pp} and $f = 1$ KHz.

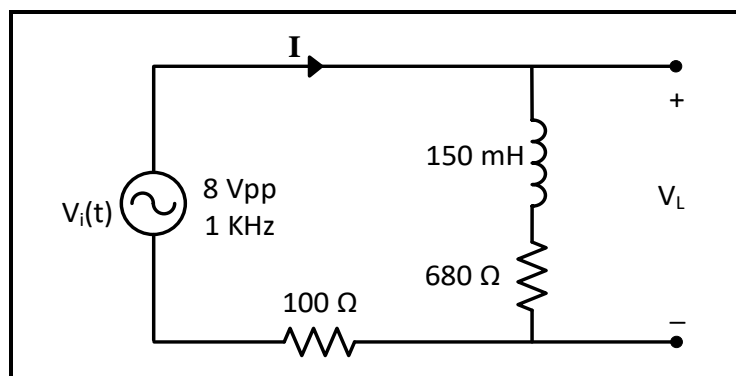

Figure 8.6

2. Connect CH1 of the oscilloscope across V_{in} and CH2 across the 100 Ω resistor (the voltage across the resistor has the same waveform and angle as the current since $V = I \times R$).

3. Use cursors to measure the time difference between V_{in} and $V_{100\Omega}$, record result in Table 8.3, take a picture of the oscilloscope screen with cursors shown, to be added to the report.

4. Measure the RMS value of: V_L and I using **DMM**, record results in Table 8.3.

Question 5: Calculate the phase shift $\Delta\theta$ between V_{in} and $V_{100\Omega}$ signals using $\{\Delta\theta = 360^\circ \times f \times \Delta t\}$, ($\Delta\theta$ here represents the angle of the current, as the input voltage is assumed to be at zero angle), record results in Table 8.3.

Question 6: Calculate the power factor of the circuit using measured data in Table 8.3, record results in Table 8.3. Indicate whether the load power factor is leading or lagging,

Question 7: Calculate the average power P and the reactive power Q delivered to the load using measured data in Table 8.3, record results in Table 8.3.

➤ **PART D: Power factor correction**

1. For the circuit of figure 8.6: connect the capacitor value that you calculated in your prelab to correct the power factor to unity, in parallel with the load as shown in figure 8.7.

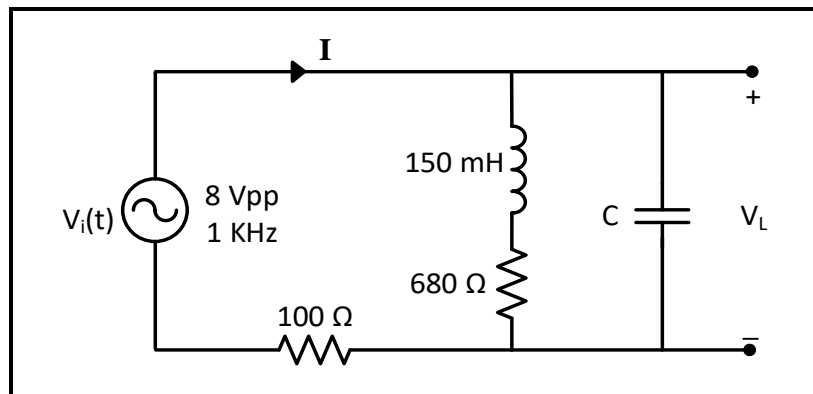

Figure 8.7

2. Connect CH1 of the oscilloscope across V_{in} and CH2 across the $100\ \Omega$ resistor, take a picture of the oscilloscope screen to be added to the report.

3. Measure the RMS value of: V_L and I using **DMM**, record results in Table 8.4.

Question 8: Calculate the new: power factor, average power P , and reactive power Q of the load using the data in Table 8.4, record results in the same table. Discuss the effect of adding the capacitor on the measured and calculated values of Table 8.4.

➤ **PART E: Maximum average power transfer**

1. For the circuit shown in Figure 8.8: connect the load, that you designed in your prelab in order to get the maximum power transfer to the load, to the circuit terminals.

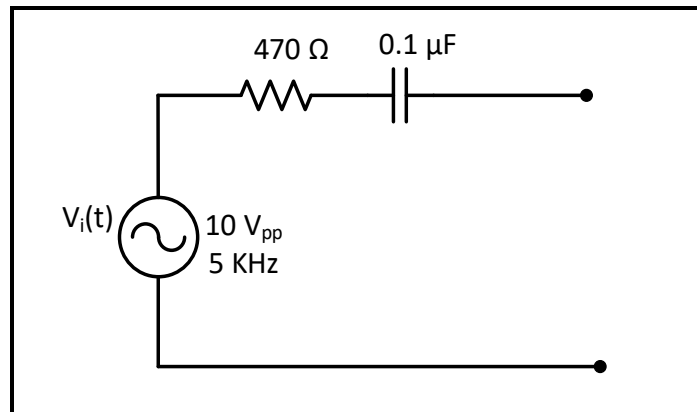

Figure 8.8

2. Measure the load current, record result in the indicated place in data sheet.

Question 9: Calculate the average power that is delivered to the load ($P = I^2 \times R$), compare it with the value of P_{Max} calculated in prelab.

➤ **PART F: Measuring power using Wattmeter**

1. Connect the circuit of Figure 8.9, with the output of the power supply set to 12 V_{RMS} .

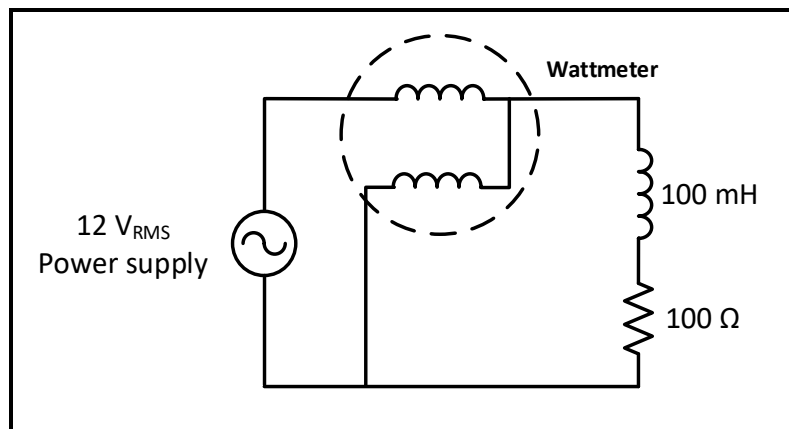

Figure 8.9

2. Measure power dissipated by total circuit (Resistor + Inductor), record results in Table 8.5.
3. Measure power dissipated by 100 Ω alone using wattmeter, record result in Table 8.5.
4. Measure power dissipated by 100 mH alone using wattmeter, record results in Table 8.5.

Before Leaving the Laboratory

Be sure the following is completed before you leave the laboratory.

- (j) Check to be sure that you have all the required measured values.
- (k) Have the laboratory instructor check your laboratory readings.

(1) Restore your laboratory station (equipment and chairs) to the condition they were in when you arrived.

Thank you for your cooperation.

Experiment 9

Passive Filters Analysis

➤ **Objectives:**

1. Analysis of first order passive filters.

➤ **Equipment's Required:**

1. Digital Multimeter GDM-8135.
2. Oscilloscope TDS 2002B.
3. Function Wave Generator GFG-8215a.
4. Resistors, capacitors, and inductors.

➤ **Introduction:**

Low-Pass first order Filter:

The series RC circuit shown in Figure 9.1 behaves as a low-pass filter. Note that the circuit's output is defined as the output across the Resistive load. We use three frequency regions to develop the behavior of the series RC circuit in

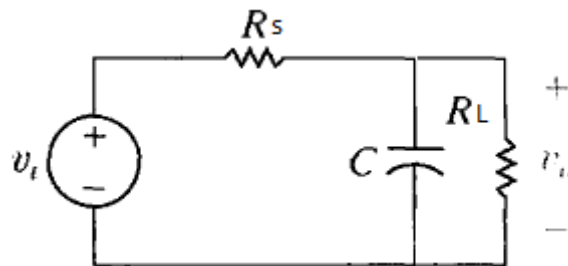

Figure 9.1 RC low pass filter

1. Zero frequency: The impedance of the capacitor is infinite, and the capacitor acts as an open circuit and therefore,

$$V_o = \frac{R_L}{R_L + R_S} V_s$$

2. As the frequency increases, the impedance of the parallel combination of C and R_L decreases, causing the output voltage to get smaller.
3. At infinite frequency: The impedance of the capacitor is zero, and the capacitor acts as a short circuit. The output voltage is thus zero.

A low pass first-order transfer function is of the form

$$H(S) = K \frac{\omega_c}{S + \omega_c}$$

$$K = \frac{R_L}{(R_L + R_s)}$$

$$\omega_c = 1/C (R_L || R_s)$$

$$|H(j\omega)| = \frac{k}{\sqrt{(1 + (\omega/\omega_c)^2)}}$$

Another circuit that behave as a first order low pass filter is shown in Figure 9.2

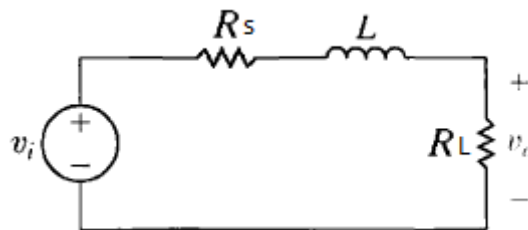

Figure 9.2 RL low pass filter

$$H(S) = K \frac{\omega_c}{S + \omega_c}$$

$$K = R_L / (R_L + R_s)$$

$$\omega_c = (R_L + R_s) / L$$

$$|H(j\omega)| = \frac{k}{\sqrt{(1 + (\omega/\omega_c)^2)}}$$

High-Pass first order Filters:

A series RC circuit is shown in Figure 9.3. In contrast to its low-pass the output voltage here is defined across the resistive load, not the capacitor. Because of this, the effect of the

changing capacitive impedance is different than it was in the low-pass configuration

At $\omega = 0$, the capacitor behaves like an open circuit, so there is no current flowing in the resistor and $V_o = 0$.

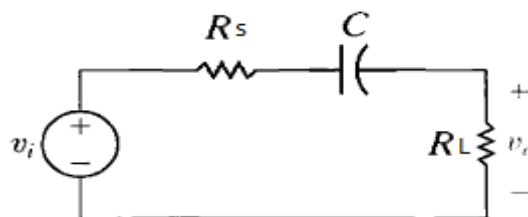

Figure 9.3 RC high pass filter

As the frequency of the voltage source increases, the impedance of the capacitor decreases causing the output voltage to increase.

When the frequency of the source is infinite ($\omega = \infty$), the capacitor behaves as a short circuit, and thus the output voltage reaches its maximum value which is equal to

$$V_o = \frac{R_L}{R_L + R_S} V_s$$

A high pass first-order transfer function is of the form

$$H(S) = K \frac{S}{S + \omega_c}$$

$$K = R_L / (R_L + R_S)$$

$$\omega_c = 1/C (R_L + R_S)$$

$$|H(j\omega)| = \frac{k}{\sqrt{1 + (\omega_c/\omega)^2}}$$

Another circuit that behave as a first order high pass filter is shown in Figure 9.4

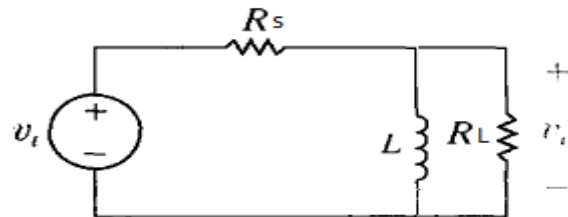

Figure 9.4 RL high pass filter

$$H(S) = K \frac{S}{S + \omega_c}$$

$$K = R_L / (R_L + R_S)$$

$$\omega_c = (R_L \parallel R_S) / L$$

$$|H(j\omega)| = \frac{k}{\sqrt{1 + (\omega_c/\omega)^2}}$$

RLC Bandpass Filter:

Figure 9.5 depicts a series RLC circuit. We want to consider the effect of changing the source frequency on the magnitude of the output voltage. As before, changes to the source frequency result in changes to the impedance of the capacitor and the inductor. The qualitative analysis is somewhat more complicated, because the circuit has both an inductor and a capacitor.

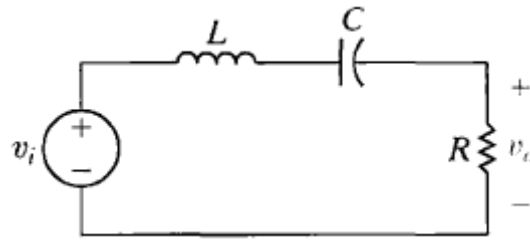

Figure 9.5 Bandpass Filter

At $\omega = 0$, the capacitor behaves like an open circuit, and the inductor behaves like a short circuit. The open circuit representing the impedance of the capacitor prevents current from reaching the resistor, and the resulting output voltage is zero.

At $\omega = \infty$, the capacitor behaves like a short circuit, and the inductor behaves like an open circuit. The inductor now prevents current from reaching the resistor, and again the output voltage is zero.

But what happens in the frequency region between $\omega = 0$ and $\omega = \infty$? Between these two extremes, both the capacitor and the inductor have finite impedances. In this region, voltage supplied by the source will drop across both the inductor and the capacitor, but some voltage will reach the resistor. Remember that the impedance of the capacitor is negative, whereas the impedance of the inductor is positive. Thus, at some frequency, the impedance of the capacitor and the impedance of the inductor have equal magnitudes and opposite signs; the two impedances cancel out, causing the output voltage to equal the source voltage. This special frequency is the center frequency, ω_0 . On either side of ω_0 , the output voltage is less than the source voltage. Note that at ω_0 , the series combination of the inductor and capacitor appears as a short circuit. Resonance in AC circuits implies a special frequency determined by the values of the resistance, capacitance, and inductance. For series resonance the condition of resonance is straightforward and it is characterized by minimum impedance and zero phase. The resonance of a series RLC circuit occurs when the inductive and capacitive reactance's are equal in magnitude but cancel each other because they are 180 degrees apart in phase. The sharp minimum in impedance which occurs is useful in tuning applications. The sharpness of the minimum depends on the value of R and is characterized by the "Q" of the circuit.

Use S domain voltage division to write an equation for the transfer function:

$$H(s) = \frac{(R/L)s}{s^2 + (R/L)s + (1/LC)}$$

IF $V_i = V_m \cos(\omega t)$, then $i = I_m \cos(\omega t + \theta)$

The frequency at which the reactance's of the inductance and the capacitance cancel each other is the resonant frequency (or the unity power factor frequency) of this circuit. This occurs at

$$\omega_o = \frac{1}{\sqrt{LC}}$$

Since $i = VR / R$, then the current i can be studied by studying the voltage across the resistor.

The current i has the expression

$$i = I_m \cos(\omega t + \theta)$$

$$I_m = \frac{V_m}{\sqrt{R^2 + \left(\omega L - \frac{1}{\omega C}\right)^2}}$$

$$\theta = -\tan^{-1} \left(\frac{\omega L - \frac{1}{\omega C}}{R} \right)$$

The bandwidth of the series circuit is defined as the range of frequencies in which the amplitude of the current is equal to or greater than $(1 / 2^{0.5})$ times its maximum amplitude, as shown in fig. 2. This yields the bandwidth $B = \omega_2 - \omega_1 = R/L$ where

$$\omega_{2,1} = \sqrt{\left(\frac{R}{2L}\right)^2 + \frac{1}{LC}} \pm \frac{R}{2L}$$

$\omega_{2,1}$ are called the half power frequencies or the 3 dB frequencies, i.e the frequencies at which the value of I_m equals the maximum possible value divided by $2^{0.5} = 1.414$.

The quality factor

$$Q = \frac{\omega_o}{B} = \frac{1}{R} \sqrt{\frac{L}{C}}$$

Then the maximum value of :

1- VR occurs at $\omega = \omega_o$

2- VL occurs at $\frac{\omega_o}{\sqrt{1 - \frac{R^2 C}{2L}}}$

3- VC occurs at $\omega_o \sqrt{1 - \frac{R^2 C}{2L}}$

The bandwidth from the cutoff frequencies:

$$\beta = \omega_{c2} - \omega_{c1} = \frac{R}{L}$$

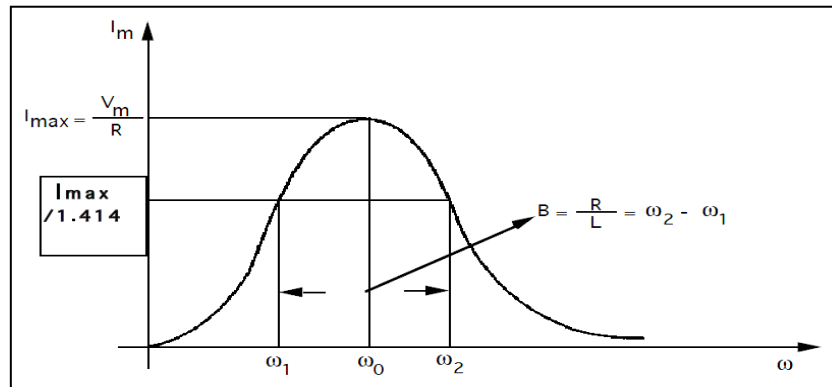

Figure 9.6 Frequency Response of band pass filter

Band reject Filters:

We turn now to the last of the four filter categories—the band reject filter. This filter passes source voltages outside the band between the two cutoff frequencies to the output (the pass band) and attenuates source voltage before they reach the output at frequencies between the two cutoff frequencies (the stop band). Band pass filters and band reject filters thus perform complementary functions in the frequency domain. Band reject filters are characterized by the same parameters as band pass filters: the two cutoff frequencies, the center frequency, the bandwidth, and the quality factor. Again, only two of these five parameters can be specified independently.

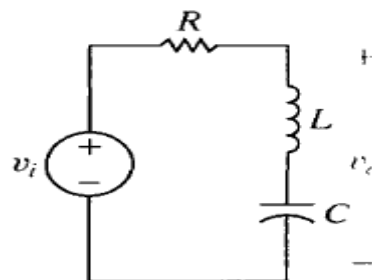

Figure 9.7 A series RLC band reject filter.

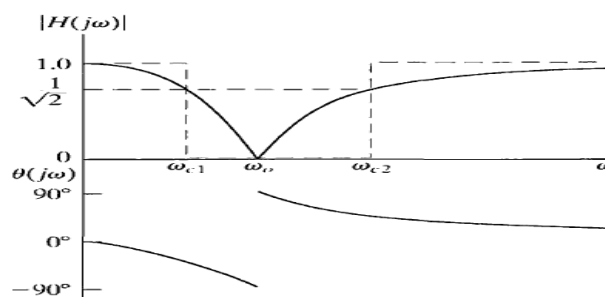

Figure 9.8 The frequency response plot for the series RLC band reject filter

For the band reject filter, the center frequency is still defined as the frequency for which the sum of the impedances of the capacitor and inductor is zero. In the band pass filter, the magnitude at the center frequency was a maximum, but in the band reject filter, this magnitude is a minimum. This is because in the band reject filter, the center frequency is not in the pass band; rather, it is in the stop band. It is easy to show that the center frequency is given by

$$\omega_o = \sqrt{\frac{1}{LC}}$$

the cutoff frequencies

$$\omega_{c1} = -\frac{R}{2L} + \sqrt{\left(\frac{R}{2L}\right)^2 + \frac{1}{LC}},$$

$$\omega_{c2} = \frac{R}{2L} + \sqrt{\left(\frac{R}{2L}\right)^2 + \frac{1}{LC}}.$$

$$\beta = R/L.$$

The quality factor, Q:

$$Q = \sqrt{\frac{L}{R^2C}}$$

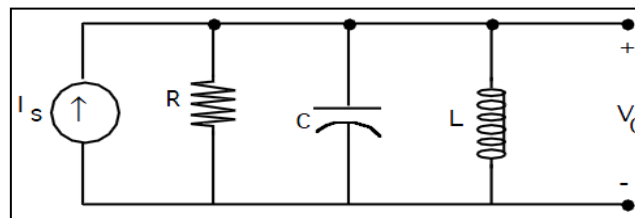

Figure 9.9 A Parallel band pass filter.

If $I_s = I_m \cos(\omega t)$, then $V_o = V_m \cos(\omega t + \theta)$ where

$$V_m = \frac{I_m}{\sqrt{\frac{1}{R^2} + \left(\omega C - \frac{1}{\omega L}\right)^2}}$$

$$\theta = -\tan^{-1}\left(R\left(\omega C - \frac{1}{\omega L}\right)\right)$$

The resonant frequency is

$$\omega_o = \frac{1}{\sqrt{LC}}$$

The 3 dB frequencies are:

$$\omega_{2,1} = \sqrt{\left(\frac{1}{2RC}\right)^2 + \frac{1}{LC}} \pm \frac{1}{2RC}$$

The bandwidth $B = \omega_2 - \omega_1 = 1/RC$.

The quality factor:

$$Q = \frac{\omega_0}{B} = R\sqrt{\frac{C}{L}}$$

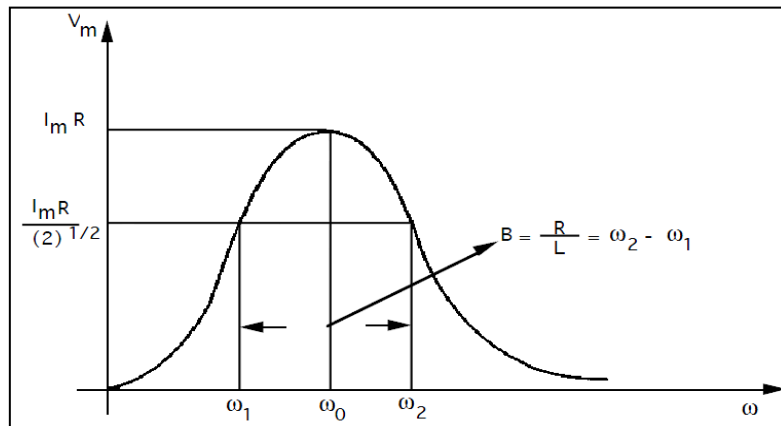

Figure 9.10 Frequency Response of the band pass filter

➤ **Pre-Lab**

1. Calculate the cut-off frequency (f_c) for the high pass and low pass filters shown in Figures 9.13 and 9.14 (use the formulas in the introduction of experiment).
2. Simulate the circuits mentioned in step 1 using ac sweep with a Vac source at 1 V amplitude, for each of the circuits plot the magnitude in decibel scale (dB (Vo)) and phase $p(V_o)$.
3. The setting of Vac source are shown in the figure 9.11.

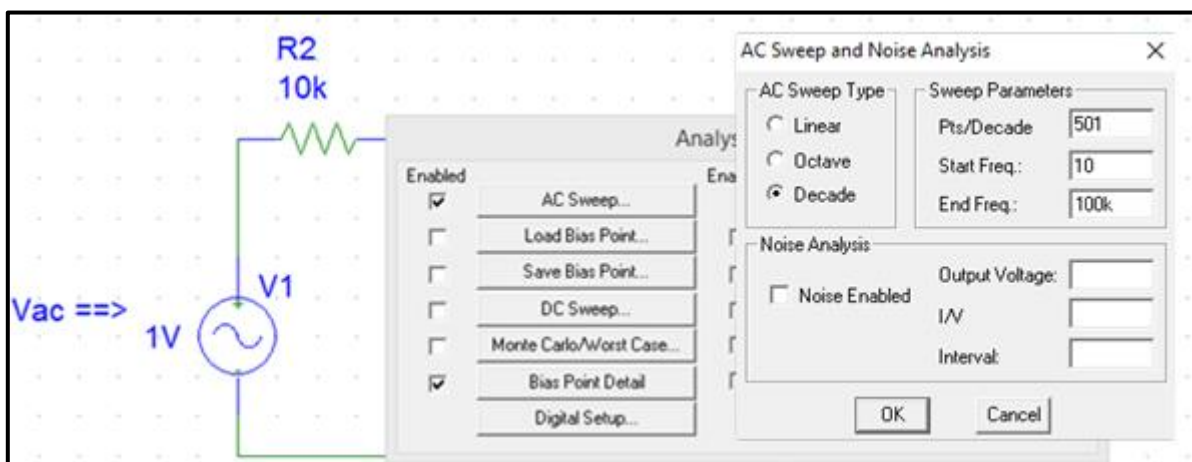
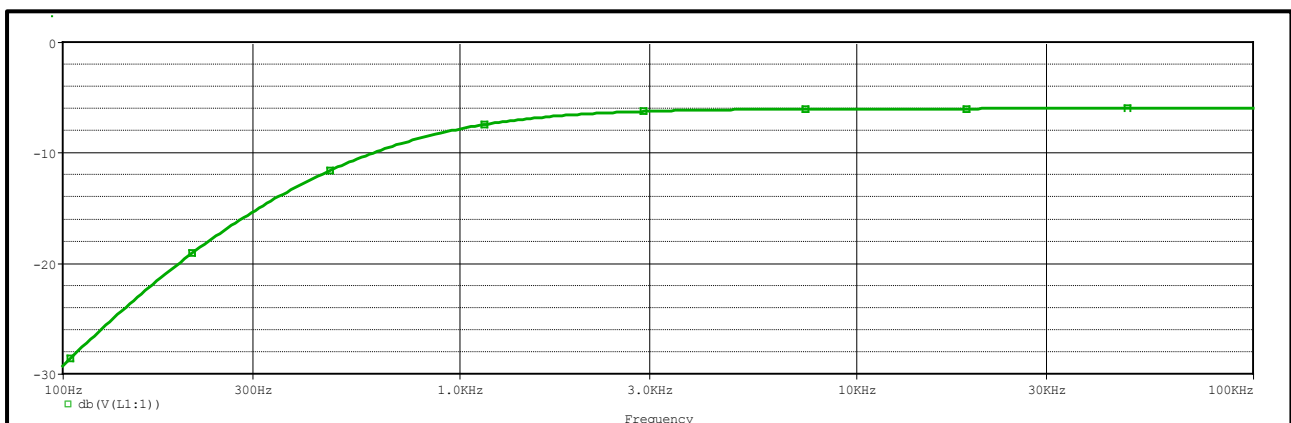

Figure 9.11



4. The output waveform will be similar to the figure 9.12.

Figure 9.12

5. Calculate the center frequency (f_0), two cut-off frequencies (f_{C1} and f_{C2}), and bandwidth (β) in Hertz for the circuit in Figure 9.15 with two values of R (3.2 k Ω and 1.6 k Ω)
6. Repeat step 2 for the circuits mentioned in step 5.

7. Calculate the center frequency (f_0), two cut-off frequencies (f_{C1} and f_{C2}), and bandwidth (β) in Hertz for the circuit in Figure 9.16 with two values of R (7.1 k Ω and 3.5 k Ω)
8. Repeat step 2 for the circuits mentioned in step 7.

➤ **Procedure:**

➤ **Part A: First-order RC High Pass Filter**

1. Connect the circuit of Figure 9.13, with a sinusoidal input voltage at 1 V_{RMS}.

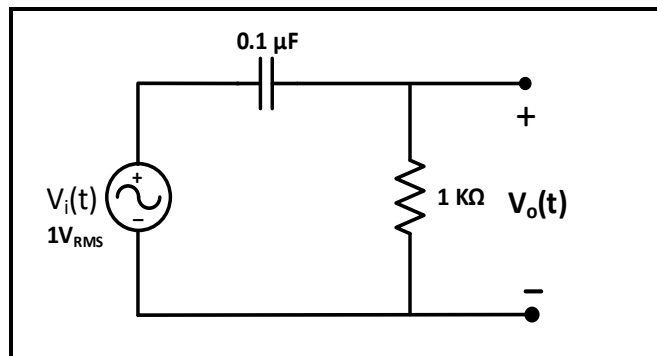

Figure 9.13

2. Observe the filter's response by increasing frequency starting from a low value (30 Hz) to a high value (30 kHz) while monitoring V_O **using DMM**, notice the range of frequencies where V_O is minimum (near 0), and the range where V_O is maximum (near to 1 V).
3. To determine the cutoff frequency (f_C) **experimentally**, connect **DMM** across V_O and change the frequency until V_O is around $V_{max}/\sqrt{2}$, at this point the frequency is (f_C), record its value in Table 9.1.
4. Change the frequency according to Table 9.1, measure V_O **using DMM** and record results in the same table.

Question 1: In your report use data in Table 9.1 to plot $\{(20 \log V_O) \text{ vs. } (f)\}$ using excel (use decade scale x-axis), discuss the plot's behavior comparing experimental value of (f_C) to its theoretical value.

➤ **Part B: First-order RC Loaded Low Pass Filter**

1. Connect the circuit of Figure 9.14, with a sinusoidal input voltage at 1 V_{RMS}.

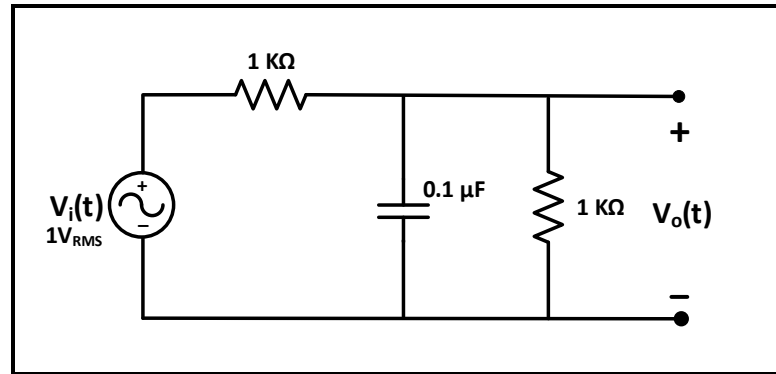

Figure 9.14

2. Observe the filter's response by increasing frequency starting from a low value (30 Hz) to a high value (200 kHz) while monitoring V_O using DMM, notice the range of frequencies where V_O is minimum (near 0), and the range where V_O is maximum (near to 0.5 V).
3. Repeat steps (3-4) in part A for the circuit of figure 9.14 but change frequency according to Table 9.2 staying in the range (30 Hz-200 kHz), and record results in the same table.

Question 2: Repeat same procedure in question 1 for data in Table 9.2 and discuss the effect of loading the filter on V_O and f_C .

➤ **Part C: Parallel RLC Band Pass Filter**

1. Connect the circuit of Figure 9.15, with a sinusoidal input voltage at 1 V_{RMS} , use decade box for R.

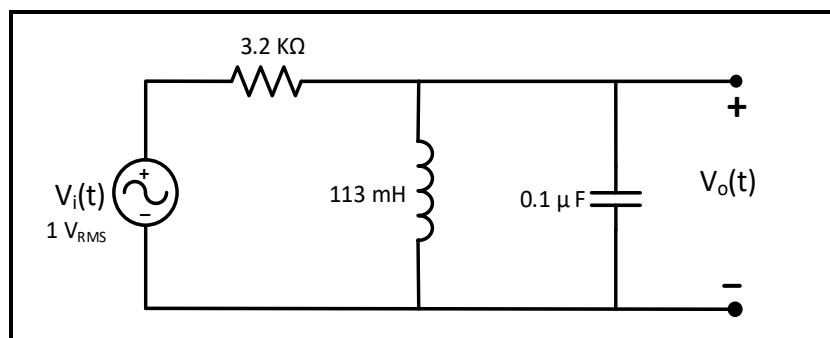

Figure 9.15

2. Observe filter's response by increasing the frequency starting from a low value (100 Hz) to a high value (30 kHz) while monitoring V_O using DMM, notice the range of frequencies where V_O is minimum (near to 0), and the range where V_O is maximum (near to 1 V).
3. To determine the center frequency (f_0) experimentally, change the frequency until V_O is around $V_{Max} = 1$ V, at this point (f) is the center frequency (f_0) record its value in Table 9.3.

4. To determine cutoff frequencies (f_{C1} and f_{C2}) **experimentally**, change the frequency until V_O is around $(V_{\max}/\sqrt{2})$, there will be two points, record the two values of (f) in Table 9.3.
5. Connect the **DMM** across V_O , then change the frequency in steps so that V_O is equal to the values listed in Table 9.3, record the corresponding values of frequency in Table 9.3.

Question 3: In your report use data in Table 9.3 to plot $\{(20\log V_O) \text{ vs. } (f)\}$ using excel (use log scale for x-axis). From the plot calculate the bandwidth (β) and discuss the plot's behavior comparing experimental values of (f_0), (f_{C1} and f_{C2}), and (β) to their theoretical value.

6. Repeat steps (3-5) for the circuit of figure 9.15 using $R = 1.6 \text{ k}\Omega$, record results in Table 9.4.

Question 4: Repeat same procedure in question 3 for data in Table 9.4 and discuss the effect of changing R on the values of (f_0), (f_{C1} and f_{C2}), and (β) as compared to previous question.

➤ **Part D: Series RLC Band Reject Filter**

1. Connect the circuit of Figure 9.16, with a sinusoidal input voltage at 1 V_{RMS} , use decade box for R.

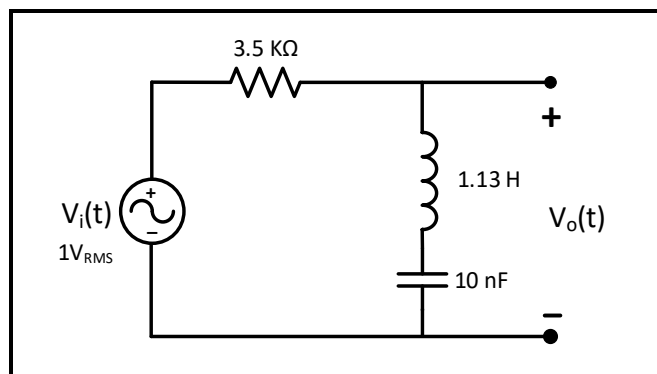

Figure 9.16

2. Observe filter's response by increasing frequency starting from a low value (100 Hz) to a high value (10 kHz) while monitoring V_O **using DMM**, notice the range of frequencies where V_O is minimum (near to 0 V), and the range where V_O is maximum (near to 1 V).
3. To determine center frequency (f_0) **experimentally**, change frequency until V_O is around V_{Min} , at this point (f) is the center frequency (f_0) record its value in Table 9.5.
4. To determine cutoff frequencies (f_{C1} and f_{C2}) **experimentally**, change the frequency until V_O is around $(V_{\max}/\sqrt{2})$, there will be two points, record the two values of (f) in Table 9.5.

5. Connect the **DMM** across V_O , then change the frequency in steps so that V_O is equal to the values listed in Table 9.5, record the corresponding values of frequency in Table 9.5.

Question 5: Repeat the same procedure in question 3 for the data in Table 9.5.

6. **Repeat steps (3-5) for the circuit of figure 9.16 using $R = 7.1 \text{ k}\Omega$, record results in Table 9.6.**

Question 6: Repeat same procedure in question 3 for data in Table 9.6 and discuss the effect of changing R on the values of (f_0) , $(f_{C1}$ and $f_{C2})$, and (β) as compared to previous question.

Before Leaving the Laboratory

Be sure the following is completed before you leave the laboratory.

(m) Check to be sure that you have all the required measured values.

(n) Have the laboratory instructor check your laboratory readings.

(o) Restore your laboratory station (equipment and chairs) to the condition they were in when you arrived.

Thank you for your cooperation.

Experiment 10

Active Filters Analysis

➤ **Objectives:**

1. Analysis of Active filters.

➤ **Equipment's Required:**

1. Digital Multimeter GDM-8135.
2. Oscilloscope TDS 2002B.
3. Function Wave Generator GFG-8215a.
4. DC power supply.
5. uA74a IC.
6. Discrete Components

➤ **Introduction:**

First-Order Low-Pass and High-Pass Filters:

Consider the circuit in Figure 10.1. Qualitatively, when the frequency of the source is varied, only the impedance of the capacitor is affected. At very low frequencies, the capacitor acts like an open circuit, and the op amp circuit acts like an amplifier with a gain of $-R_2/R_1$. At very high frequencies, the capacitor acts like a short circuit, thereby connecting the output of the op amp circuit to ground. The op amp circuit in Figure 10.1 thus functions as a low-pass filter with a passband gain $K = -R_2/R_1$

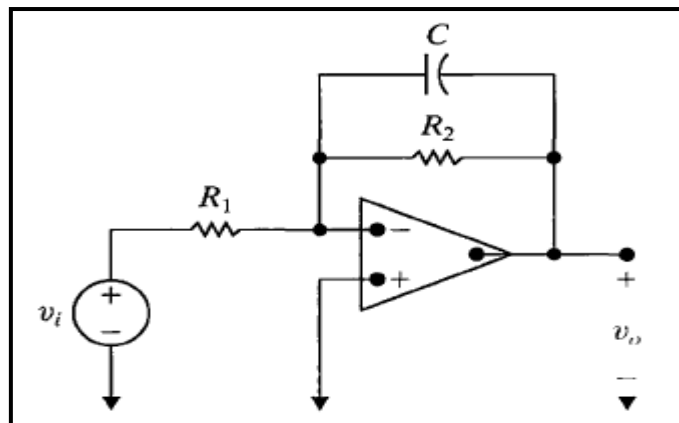

Figure 10.1: First Order Active Low Pass Filter

To confirm this qualitative assessment, we can compute the transfer function $H(s) = V_0(s)/V_i(s)$. Note that the circuit in Figure 10.1 has the general form of the circuit shown in

Figure 10.2, where the impedance in the input path (Z_i) is the resistor R_1 and the impedance in the feedback path (Z_f) is the parallel combination of the resistor R_2 and the capacitor C .

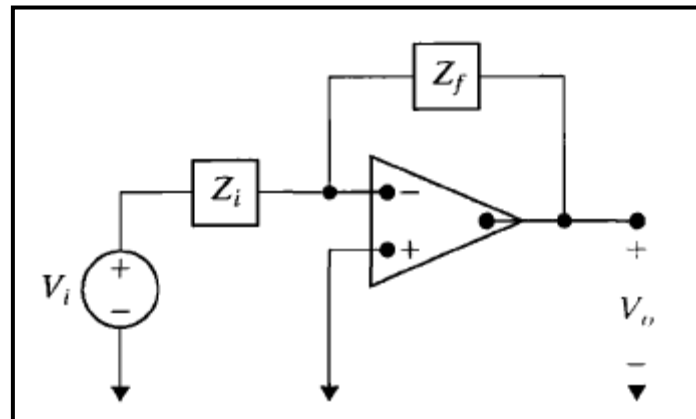

Figure 10.2: General Form of Filter Circuits

The circuit in Figure 10.2 is analogous to the inverting amplifier circuit, so its transfer function is Z_f/Z_i . Therefore, the transfer function for the circuit in Figure 10.1 is:

$$H(s) = -\frac{Z_f}{Z_i} = \frac{-R_2 \parallel (\frac{1}{sC})}{R_1} = -K \frac{\omega_c}{s + \omega_c}$$

$$K = \frac{R_2}{R_1}, \quad \omega_c = \frac{1}{R_2 C}$$

The circuit in Figure 10.3 is a first-order high-pass filter. This circuit also has the general form of the circuit in Figure 10.2, only now the impedance in the input path is the series combination of R_1 and C , and the impedance in the feedback path is the resistor R_2 . The transfer function for the circuit in Figure 10.3 is thus

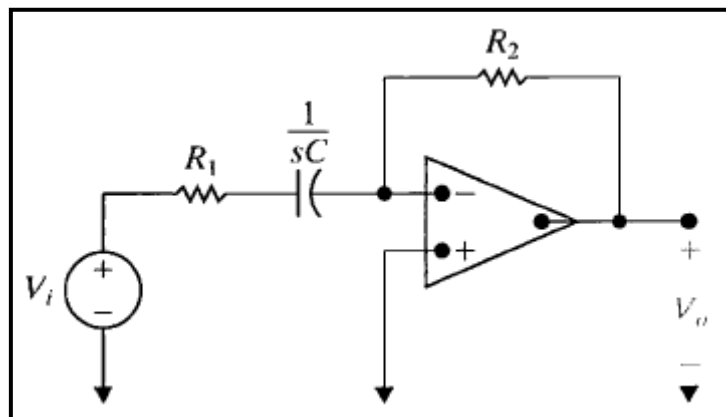

Figure 10.3: First Order Active High Pass Filter

$$H(s) = -\frac{Z_f}{Z_i} = \frac{-R_2}{R_1 + (\frac{1}{sC})} = -K \frac{s}{s + \omega_c}$$

$$K = \frac{R_2}{R_1}, \quad \omega_c = \frac{1}{R_1 C}$$

Second -Order Low-Pass and High-Pass Butterworth Filters:

Second order Butterworth filters may be designed using the circuit shown in Figure 10.4 illustrated as a low pass filter. Interchanging the positions of both R with both C will result in a high pass filter at the same critical frequency. In either case the critical frequency, f_c is:

$$f_c = \frac{1}{2\pi RC}$$

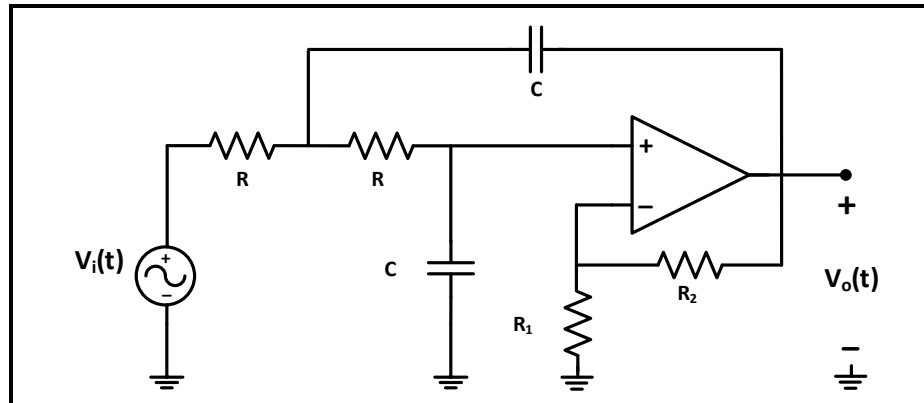

Figure 10.4: Second Order Butterworth low Pass Filter

Active Band pass and band reject filters:

Review section 15.5 in your circuit course textbook.

➤ Pre-Lab

1. Calculate the cut-off frequencies for the low pass and high pass filter circuits shown in Figure 10.5, 10.6, 10.7, and 10.8.
2. Simulate the circuits in step 1 using ac sweep, use Vac source with 1 V amplitude, and use UA741 Op-amp with +/-15V bias
3. For each circuit: plot the magnitude and phase. Don't forget to indicate the cutoff frequencies on these plots.
4. Calculate the resonant/center frequency and the two cut-off frequencies for the band-pass and band-reject filter circuits given in Figure 10.9 and Figure 10.10.
5. Repeat steps 2, 3 for circuits in step 4.

➤ **Procedure:**

➤ **Part A: First order active low-pass filter**

1. Connect the circuit of Figure 10.5, with a sinusoidal input voltage at 1 V_{RMS} .

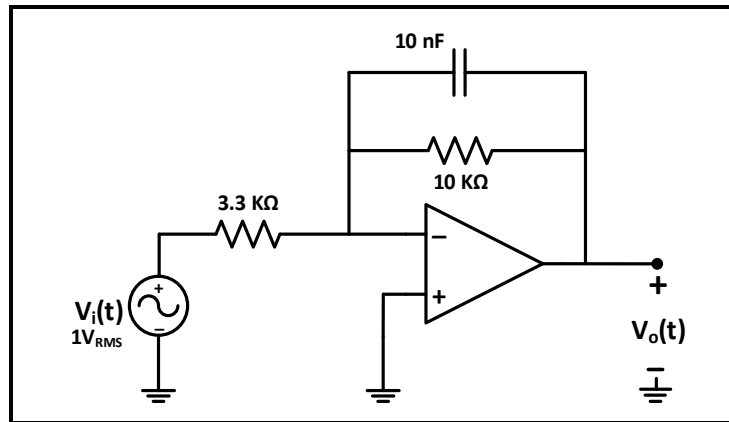

Figure 10.5: First order Active Low Pass Filter

2. Observe the filter's response by increasing the frequency starting from a low value (30 Hz) to a high value (150 kHz) while monitoring V_O **using DMM**, notice the range of frequencies where V_O is minimum (near 0), and the range where V_O is maximum (near to 3 V) Why?
3. To determine the cutoff frequency **experimentally**, change the frequency until V_O is around $V_{\text{max}}/\sqrt{2}$, at this point the frequency is (f_C), record the value in Table 10.1.
4. Change the frequency according to Table 10.1, measure V_O **using DMM** and record results in the same table.

Question 1: In your report use data in Table 10.1 to plot $\{(20\log V_O) \text{ vs. } (f)\}$ using excel (use decade scale x-axis), discuss the plot's behavior comparing experimental value of (f_C) to its theoretical value, also discuss the effect of using active filters on V_O .

➤ **Part B: Second Order Low Pass Butterworth Filter**

1. Connect the circuit of Figure 10.6, with a sinusoidal input voltage at 1 V_{RMS} .

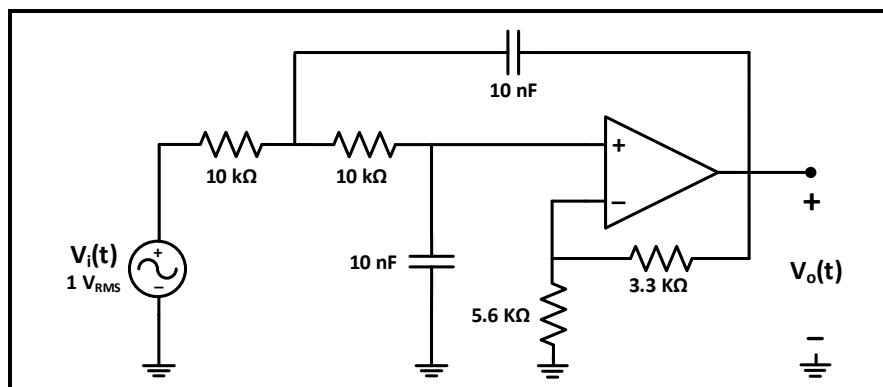

Figure 10.6: Second Order Low Pass Butterworth Filter

2. Repeat the same steps in part A for the circuit of figure 10.6 but change frequency according to Table 10.2 **staying in the range (100 Hz-30 kHz)**, and record results in the same table.

Question 2: In your report use data in Table 10.2 to plot $\{(20\log V_O) \text{ vs. } (f)\}$ using excel (use decade scale x-axis), discuss the plot's behavior comparing experimental value of (f_c) to its theoretical value, also compare second and first order filters behavior.

➤ **Part C: First order active high -pass filter**

1. Connect the circuit of Figure 10.7, with a sinusoidal input voltage at $1 V_{RMS}$, use decade box for $R = 30 K\Omega$.

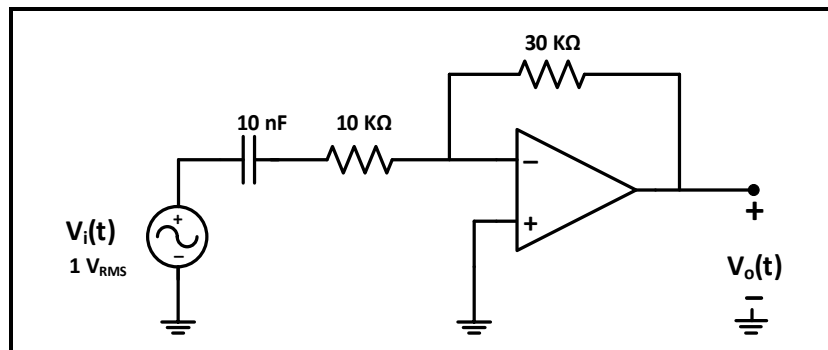

Figure 10.7: First Order Active High-Pass Filter

2. Repeat the same steps in part A for the circuit of figure 10.7 but change frequency according to Table 10.3 **staying in the range (30 Hz-10 kHz)**, and record results in the same table.

Question 3: Repeat the same procedure in question 1 for the data in Table 10.3.

➤ **Part D: Second Order High Pass Butterworth Filter**

1. Connect the circuit of Figure 10.8, with a sinusoidal input voltage at $1 V_{RMS}$.

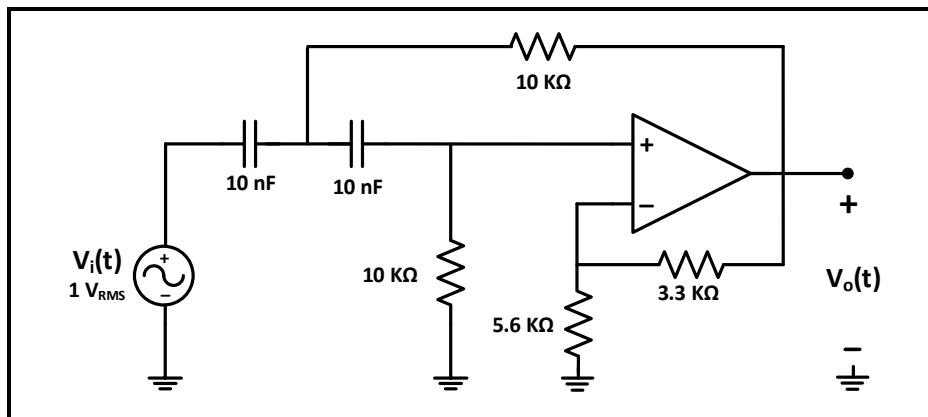

Figure 10.8: Second Order High Pass Butterworth Filter

- Repeat the same steps in part A for the circuit of figure 10.8 but change frequency according to Table 10.4 **staying in the range (100 Hz-10 kHz)**, and record results in the same table.

Question 4: Repeat the same procedure in question 2 for the data in Table 10.4.

➤ **Part E: Active band-pass filter**

- Connect the circuit of Figure 10.9, with a sinusoidal input voltage at $1 V_{RMS}$.

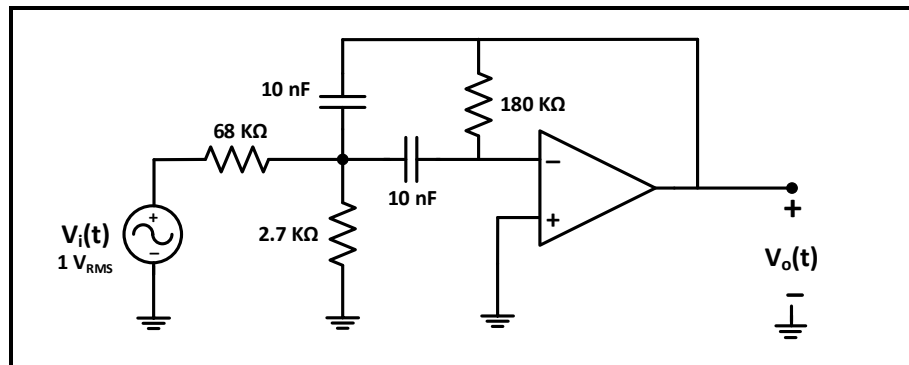

Figure 10.9: Active band pass filter

- Observe the filter's response by increasing the frequency starting from a low value (30 Hz) to a high value (10 kHz) while monitoring V_O **using DMM**, notice the range of frequencies where V_O is minimum (near to 0), and the range where V_O is maximum (near to 1.2 V).
- To determine center frequency (f_0) **experimentally**, change frequency until V_O is around V_{Max} , at this point (f) is the center frequency (f_0) record its value in Table 10.5.
- To determine cutoff frequencies (f_{C1} and f_{C2}) **experimentally**, change the frequency until V_O is around $(V_{max}/\sqrt{2})$, there will be two points, record the two values of (f) in Table 10.5.
- Connect the **DMM** across V_O , then change the frequency in steps so that V_O is equal to the values listed in Table 10.5, record the corresponding values of frequency in the same table.

Question 5: In your report use data in Table 10.5 to plot $\{(20\log V_O) \text{ vs. } f\}$ using excel (use log scale for x-axis). From the plot calculate the bandwidth (β) and discuss the plot's behavior comparing experimental values of (f_0), (f_{C1} and f_{C2}), and (β) to their theoretical value.

➤ **Part F: Active band-reject filter**

- Connect the circuit of Figure 10.10, with a sinusoidal input voltage at $1 V_{RMS}$.

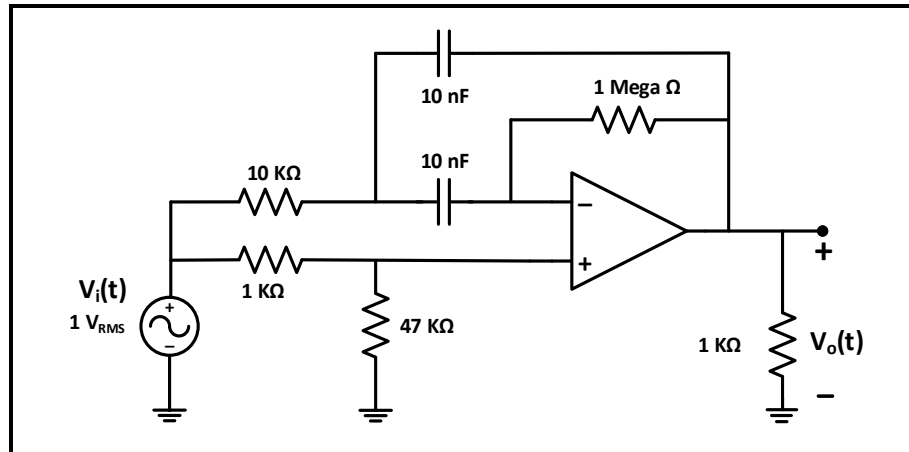

Figure 10.10: Active band reject filter

2. Observe the filter's response by increasing the frequency starting from a low value (30 Hz) to a high value (300 Hz) while monitoring V_O **using DMM**, notice the range of frequencies where V_O is minimum (near to 0.1 V), and the range where V_O is maximum (near to 1 V).
3. To determine center frequency (f_0) **experimentally**, change frequency until V_O is around V_{Min} , at this point (f) is the center frequency (f_0) record its value in Table 10.6.
4. To determine cutoff frequencies (f_{C1} and f_{C2}) **experimentally**, change the frequency until V_O is around $(V_{max}/\sqrt{2})$, there will be two points, record the two values of (f) in Table 10.6.
5. Connect the **DMM** across V_O , then change the frequency in steps so that V_O is equal to the values listed in Table 10.6, record the corresponding values of frequency in the same table.

Question 6: Repeat the same procedure in question 5 for the data in Table 10.6.

Before Leaving the Laboratory

Be sure the following is completed before you leave the laboratory.

- (p) Check to be sure that you have all the required measured values.
- (q) Have the laboratory instructor check your laboratory readings.
- (r) Restore your laboratory station (equipment and chairs) to the condition they were in when you arrived.

Thank you for your cooperation.

Experiment 11

Two-Port Networks

➤ **Objectives:**

To investigate the various parameters of two port networks.

➤ **Equipment's Required:**

1. Digital Multimeter GDM-8135.
2. Oscilloscope TDS 2002B.
3. Function Wave Generator GFG-8215a.
4. DC power supply
5. Circuit board and circuit elements.

➤ **Introduction:**

The Terminal Equations: In viewing a circuit as a two-port network, we are interested in relating the current and voltage at one port to the current and voltage at the other port. Figure 11.1 shows the reference polarities of the terminal voltages and the reference directions of the terminal currents. The references at each port are symmetric with respect to each other; that is, at each port the current is directed into the upper terminal, and each port voltage is a rise from the lower to the upper terminal. This symmetry makes it easier to generalize the analysis of a two-port network and is the reason for its universal use in the literature.

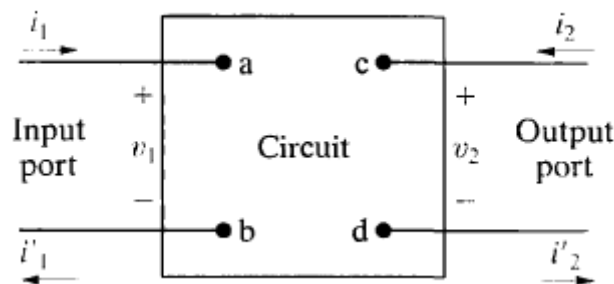

Figure 11.1 The two-port building block

The most general description of the two-port network is carried out in the s domain. For purely resistive networks, the analysis reduces to solving resistive circuits. Sinusoidal steady-state problems can be solved either by first finding the appropriate s -domain expressions and

then replacing s with $j\omega$, or by direct analysis in the frequency domain. Here, we write all equations in the s domain; resistive networks and sinusoidal steady-state solutions become special cases. Figure 11.2 shows the basic building block in terms of the s -domain variables I_1, V_1, I_2 , and V_2 .

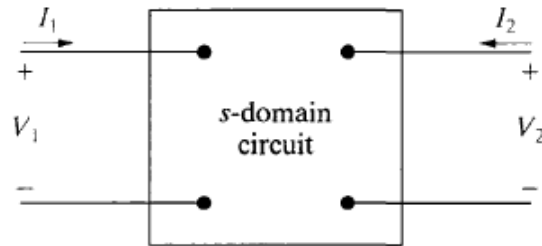

Figure 11.2 The S-domain two-port basic building block.

Of these four terminal variables, only two are independent. Thus for any circuit, once we specify two of the variables, we can find the two remaining unknowns. For example, knowing V_1 and V_2 and the circuit within the box, we can determine I_1 and I_2 . Thus we can describe a two port network with just two simultaneous equations. However, there are six different ways in which to combine the four variables:

$$V_1 = z_{11}I_1 + z_{12}I_2,$$

$$V_2 = z_{21}I_1 + z_{22}I_2;$$

$$I_1 = y_{11}V_1 + y_{12}V_2,$$

$$I_2 = y_{21}V_1 + y_{22}V_2;$$

$$V_1 = a_{11}V_2 - a_{12}I_2,$$

$$I_1 = a_{21}V_2 - a_{22}I_2;$$

$$V_2 = b_{11}V_1 - b_{12}I_1,$$

$$I_2 = b_{21}V_1 - b_{22}I_1;$$

$$V_1 = h_{11}I_1 + h_{12}V_2,$$

$$I_2 = h_{21}I_1 + h_{22}V_2;$$

$$I_1 = g_{11}V_1 + g_{12}I_2,$$

$$V_2 = g_{21}V_1 + g_{22}I_2.$$

The Two-Port Parameters:

We can determine the parameters for any circuit by computation or measurement. The computation or measurement to be made comes directly from the parameter equations. For example, suppose that the problem is to find the z parameters for a circuit.

$$z_{11} = \left. \frac{V_1}{I_1} \right|_{I_2=0} \Omega,$$

$$z_{12} = \left. \frac{V_1}{I_2} \right|_{I_1=0} \Omega,$$

$$z_{21} = \left. \frac{V_2}{I_1} \right|_{I_2=0} \Omega,$$

$$z_{22} = \left. \frac{V_2}{I_2} \right|_{I_1=0} \Omega.$$

That the four z parameters can be described as follows:

- Z11 is the impedance seen looking into port 1 when port 2 is open.
- Z12 is a transfer impedance. It is the ratio of the port 1 voltage to the port 2 current when port 1 is open.
- Z21 is a transfer impedance. It is the ratio of the port 2 voltage to the port 1 current when port 2 is open.
- Z22 is the impedance seen looking into port 2 when port 1 is open.

Therefore the impedance parameters may be either calculated or measured by first opening port 2 and determining the ratios V_1/I_1 and V_2/I_2 , and then opening port 1 and determining the ratios V_1/I_2 and V_2/I_1 .

Each parameter is the ratio of a voltage to a current and therefore is an impedance with the dimension of ohms.

We use the same process to determine the remaining port parameters, which are either calculated or measured. A port parameter is obtained by either opening or shorting a port. Moreover, a port parameter is an impedance, an admittance, or a dimensionless ratio. The dimensionless ratio is the ratio of either two voltages or two currents. The following equations summarize these observations.

$y_{11} = \frac{I_1}{V_1} \Big _{V_2=0} \text{ S},$	$y_{12} = \frac{I_1}{V_2} \Big _{V_1=0} \text{ S},$	$h_{11} = \frac{V_1}{I_1} \Big _{V_2=0} \Omega,$	$h_{12} = \frac{V_1}{V_2} \Big _{I_1=0},$
$y_{21} = \frac{I_2}{V_1} \Big _{V_2=0} \text{ S},$	$y_{22} = \frac{I_2}{V_2} \Big _{V_1=0} \text{ S}.$	$h_{21} = \frac{I_2}{I_1} \Big _{V_2=0},$	$h_{22} = \frac{I_2}{V_2} \Big _{I_1=0} \text{ S}.$
$a_{11} = \frac{V_1}{V_2} \Big _{I_2=0},$	$a_{12} = -\frac{V_1}{I_2} \Big _{V_2=0} \Omega,$	$g_{11} = \frac{I_1}{V_1} \Big _{I_2=0} \text{ S},$	$g_{12} = \frac{I_1}{I_2} \Big _{V_1=0},$
$a_{21} = \frac{I_1}{V_2} \Big _{I_2=0} \text{ S},$	$a_{22} = -\frac{I_1}{I_2} \Big _{V_2=0}.$	$g_{21} = \frac{V_2}{V_1} \Big _{I_2=0},$	$g_{22} = \frac{V_2}{I_2} \Big _{V_1=0} \Omega.$
$b_{11} = \frac{V_2}{V_1} \Big _{I_1=0},$	$b_{12} = -\frac{V_2}{I_1} \Big _{V_1=0} \Omega,$		
$b_{21} = \frac{I_2}{V_1} \Big _{I_1=0} \text{ S},$	$b_{22} = -\frac{I_2}{I_1} \Big _{V_1=0}.$		

➤ **Prelab:**

1. Simulate the circuits in Figures 11.3 to Figure 11.5 and use current and voltage values resulting from simulation to calculate the Z-parameters for each circuit, note that you must apply the same steps in the procedure.
2. Simulate the circuits in Figures 11.6 to Figure 11.8 and use current and voltage values resulting from simulation to calculate the A-parameters for each circuit, note that you must apply the same steps in the procedure. (The amplitude of the sinusoidal voltage source used in simulating circuits in this step must be $(4 \times 2 \times \sqrt{2})$ and its frequency is 1 kHz).
3. In your prelab: when simulating circuits in step 1, you have to insert a snapshot of the circuit with current and voltage values shown on it in the prelab, and when simulating circuits in step 2 you have to insert a snapshot of the circuit and the plot of the required voltages and currents in your prelab).

➤ **Procedure:**

➤ **Part A: Z-parameters and series interconnected two port networks**

1. Connect the circuit of Figure 11.3.

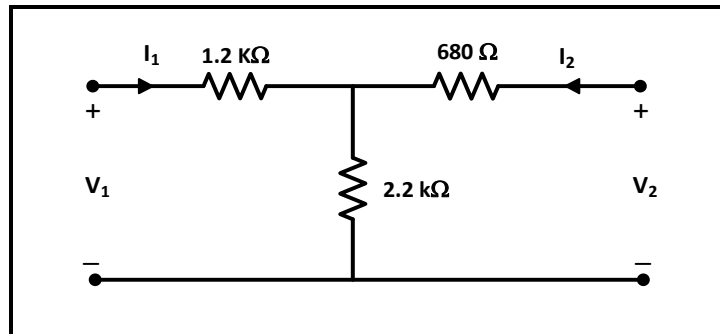

Figure 11.3

- a. Leave output port (V_2) open circuit, apply 10 V DC voltage source to input port (V_1), measure input current (I_1) and output voltage (V_2), and record results in table 11.1.
- b. Leave input port (V_1) open circuit, apply a 10 V DC voltage source to output port (V_2), measure output current (I_2) and input voltage (V_1), and record results in table 11.1.

Question 1: Using data in Table 11.1 calculate Z-parameters for the circuit of figure 11.3.

2. Connect the circuit shown in figure 11.4, repeat steps 1-(a-b) **but using 5 V DC** voltage source, and record results in Table 11.2.

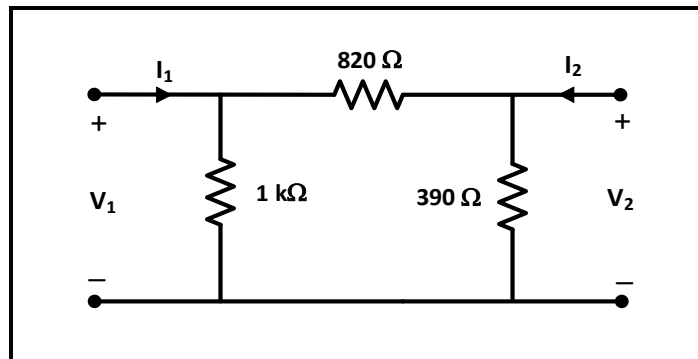

Figure 11. 4

Question 2: Using data in Table 11.2 calculate Z-parameters for the circuit of figure 11.4.

3. Connect the two circuits in figures 11.3 and 11.4 as series interconnected two port networks as shown in figure 11.5.

- a. Repeat steps 1-(a-b) for the circuit connection in figure 11.5, and record results in Table 11.3.

Question 3: Using data in Table 11.3 calculate Z-parameters for the circuit of figure 11.5, verify that the Z-parameters of the circuit in figure 11.5 is equal to the sum of the Z-parameters of the circuits in figures 11.3 and 11.4.

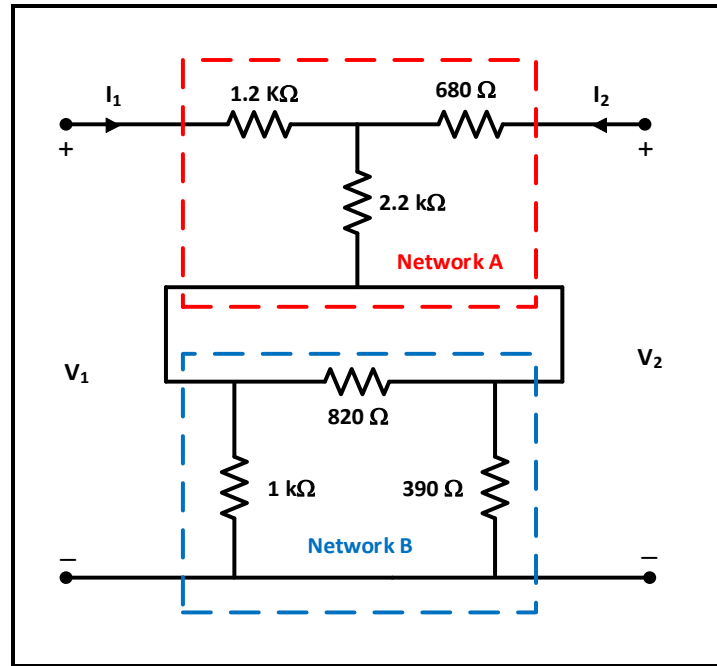

Figure 11.5

➤ **Part B: A-parameters and cascade interconnected two port networks**

1. Connect the circuit of Figure 11.6.

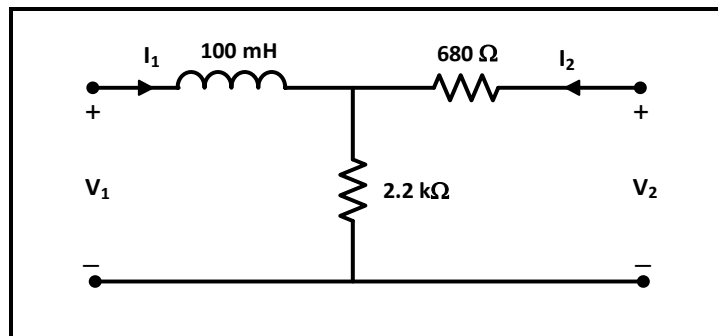

Figure 11.6

- b. Leave output port (V_2) open circuit, apply sinusoidal voltage of ($4 V_{RMS}$ and 1 kHz) to input port (V_1), measure input current (I_1) and output voltage (V_2), and record results in table 11.4.
- c. Make output port (V_2) short circuit, apply sinusoidal voltage of ($4 V_{RMS}$ and 1 kHz) to input port (V_1), measure input current (I_1) and output current (I_2), and record results in table 11.4.

Question 4: Using data in Table 11.4 calculate A-parameters for the circuit of figure 11.6.

2. Connect the circuit shown in figure 11.7, repeat steps 1-(a-b), and record results in Table 11.5.

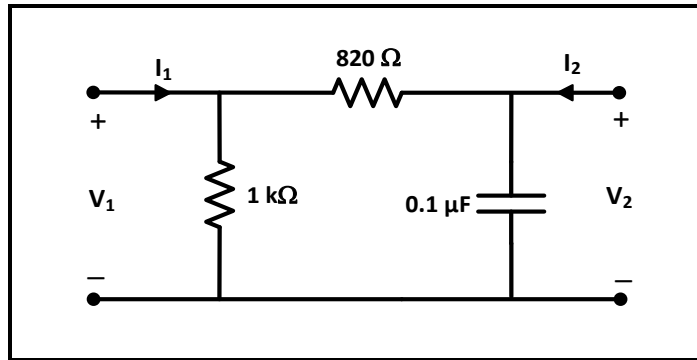

Figure 11. 7

Question 5: Using data in Table 11.5 calculate A-parameters for the circuit of figure 11.7.

3. Connect the two circuits in figures 11.6 and 11.7 as cascade interconnected two port networks as shown in figure 11.8.

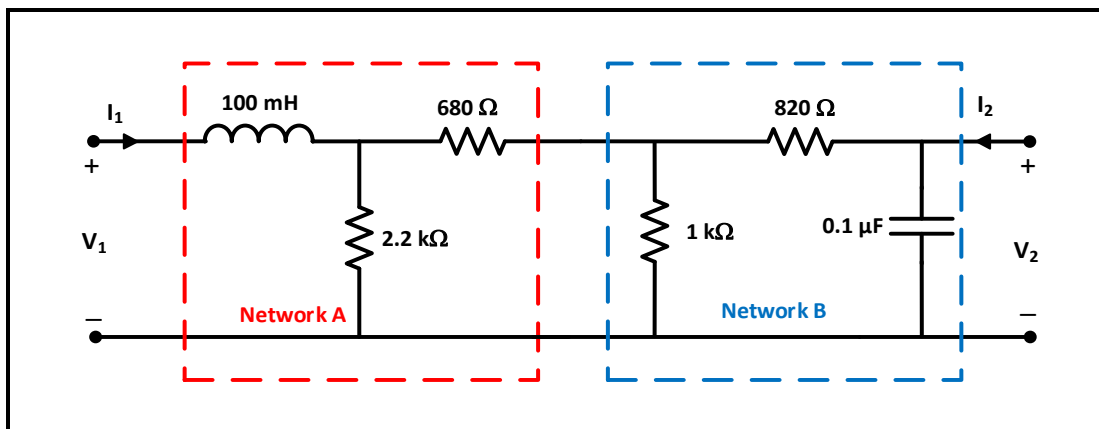

Figure 11. 8

- a. Repeat steps 1-(a-b) for circuit connection in figure 11.8, record results in Table 11.6.

Question 6: Using data in Table 11.6 calculate A-parameters for the circuit of figure 11.8, verify that A-parameters of circuit in figure 11.8 is equal to the **matrix multiplication** of A-parameters of the circuits in figures 11.6 and 11.7.

$$\begin{vmatrix} a_{11} & a_{12} \\ a_{21} & a_{22} \end{vmatrix}_{\text{Figure 11.8}} = \begin{vmatrix} a_{11} & a_{12} \\ a_{21} & a_{22} \end{vmatrix}_{\text{Figure 11.6}} \times \begin{vmatrix} a_{11} & a_{12} \\ a_{21} & a_{22} \end{vmatrix}_{\text{Figure 11.7}}$$

Before Leaving the Laboratory

Be sure the following is completed before you leave the laboratory.

- Check to be sure that you have all the required measured values.
- Have the laboratory instructor check your laboratory readings.
- Restore your laboratory station (equipment and chairs) to the condition they were in when you arrived.

Thank you for your cooperation.

Experiment 3 - Data Tables:

Part A: Kirchhoff's Laws

Table 3.1: Voltages and currents for circuit of figure 3.4

	1.2 K Ω	820 Ω	2.2 K Ω	1 K Ω	680 Ω	390 Ω
Voltage [V]						
Current [mA]						

Part B: Voltage Divider

Table 3.2

Voltage [V]	V ₁₋₂	V ₂₋₃	V ₃₋₀

Table 3.3: potentiometer values

R _{AB} [K Ω]	R _{BC} [K Ω]

Table 3.4: Voltage measurements as the resistance change from 1k to ∞

R _L	Open circuit	500 K Ω	100 K Ω	10 K Ω	1 K Ω
V _O [V]					

Part C: Current Divider

Table 3.5

I _s [mA]	I ₁ [mA]	I ₂ [mA]	I ₃ [mA]	I ₂₃ [mA]

Part D: Short-and-Open Circuited Resistor in Series-Parallel Circuits

Table 3.6: Short Circuit with R_1 , R_2 and R_3

	Normal	R_1 S C	R_2 S C
I_1 [mA]			
I_2 [mA]			
I_3 [mA]			
V_{1-2} [V]			
V_{2-3} [V]			
V_{3-0} [V]			

Table 3.7: Open Circuit with R_1 , R_2 and R_3

	R_1 O C	R_2 O C
V_{1-2} [V]		
V_{2-3} [V]		
V_{3-0} [V]		
I_1 [mA]		

Experiment 4 - Data Tables:

Part A: The Proportionality Theorem

Table 4.1

V_i	V_o [V]	$(K = V_o / V_{in})$
5 V		
10 V		

Part B: The Superposition Theorem

Table 4.2

	V (2.2 k Ω) [V]	I (2.2 k Ω) [mA]
Total Response ($V_1 = 20$ V, $V_2 = 15$ V)		
Response 1 ($V_1 = 20$ V, $V_2 = 0$ V)		
Response 2 ($V_1 = 0$ V, $V_2 = 15$ V)		
Response 1 + Response 2		

Part C: Thevenin Theorem

Table 4.3

V (680 Ω) [V]	I (680 Ω) [mA]

Table 4.4

V (open circuit) [V]	I (Short circuit) [mA]	R_{TH} (Calculate) [Ω]

Table 4.5

V_{Test} (SET)	I_{Test} (Measure) [mA]	R_{TH} (Calculate) [Ω]
4 V		

Table 4.6

R_{Th} [Ω]

Table 4.7

V (680 Ω) [V]	I (680 Ω) [mA]

Part D: Δ -Y Transformation

Table 4.8

	I [mA]	V_{ab} [V]
Delta circuit		
Wye circuit		

Part E: The Reciprocity Theorem

Table 4.9

I_1 [mA]	I_2 [mA]

Experiment 5 - Data Tables:

Part A: Step response of first-order RC circuit

Table 5.1

R_{Actual}	

Part B: Step response of first-order RL circuit

Table 5.2

R_{Actual}	R_{Inductor}

Part C: Step response of second-order Series RLC circuit

Case C: under damped response

Table 5.3

V_a	t_a	V_b	t_b	$V(\infty)$

Part D: Step response of second-order parallel RLC circuit

Case A: under damped response

Table 5.4

V_a	t_a	V_b	t_b	$V(\infty)$

Experiment 6 - Data Tables:

B.1: Phase Relationship between Transformer Primary and Secondary Voltages

Table 6.1

Measure			Calculate
V_P	V_S	θ	a (turns ratio)

B.2: Voltage, Current, Turns Ratio, and Impedance transformation

1.

Table 6.2

Measure			
V_P	V_S	I_P	I_S

Table 6.3

Calculate				
a	$Z_{P, \text{Theo}}$	$Z_{P, \text{exp}}$	S_P	S_S

2.

Table 6.4

Measure				Calculate
V_P	V_S	I_P	I_S	a

Experiment 7 - Data Tables:

Part A: Impedance Measurement

1.

Table 7.1

f [Hz]	250	500	1000	2000
V				
I				
Z _R				

2.

Table 7.2

f [Hz]	250	500	1000	2000
V				
I				
Z _C				

3.

Table 7.3

f [Hz]	250	500	1000	2000
V				
I				
Z _L				

4.

Table 7.4

f [Hz]	250	500	1000	2000
V				
I				
Z _{RC}				

Part B: Phase Measurement

1.

Table 7.5

Δt	$\Delta\theta$

2.

Table 7.6

Δt	$\Delta\theta$

Part C: Inductance and Capacitance Measurement

1.

Table 7.7

f [Hz]	$ V_R $	$ V_L $	$ I $	L
1 kHz				

2.

Table 7.8

f	$ V_R $	$ V_C $	$ I $	C
1 kHz				

Experiment 8 - Data Tables:

Part A: DC power measurement

Table 8.1

V_{in} [V]	0	2	4	6	8	10
I [mA]						
P [mW]						

Part B: Maximum DC power transfer

Table 8.2

R_L	0	100	400	700	1k	1.1k	1.2k	1.3k	1.4k	1.5k	1.7k
I [mA]											
P [mW]											

$R_{eq} =$

Part C: Power factor measurement

Table 8.3

Measure			Calculate			
V_L	I	Δt	θ_L	Pf	P [mW]	Q [mVAR]

Part D: Power factor correction

Table 8.4

Measure			Calculate			
V_L	I	Δt	θ_L	Pf	P [mW]	Q [mVAR]

PART E: Maximum average power transfer,

$I_L =$

PART F: Measuring power using Wattmeter

Table 8.5

Total Power (P_T)	Resistor Power (P_R)	Inductor Power (P_L)

Experiment 9 - Data Tables:

Part A: First-order RC High Pass Filter

Table 9.1

f [kHz]	0.03	0.1	0.3	0.6	0.9	fc	3	10	20	30
V _o [V _{RMS}]						V _{max} /√2				V _{max}
20log($\frac{V_o}{V_i}$) [dB]										

Part B: First-order RC loaded Low Pass Filter

Table 9.2

f [kHz]	0.03	0.3	2	fc	5	7.5	12	30	100	200
V _o [V _{RMS}]	V _{max}			V _{max} /√2						
20log($\frac{V_o}{V_i}$) [dB]										

Part C: Passive Band Pass Filter

For R = 3.2 kΩ

Table 9.3

V _o [V _{RMS}]	0.03	0.15	0.3	0.5	V _{max} /√2	V _{max}	V _{max} /√2	0.5	0.3	0.15	0.03
f [kHz]					f _{c1}	f ₀	f _{c2}				
20log($\frac{V_o}{V_i}$) [dB]											

For R = 1.6 kΩ

Table 9.4

V_o [V _{RMS}]	0.03	0.15	0.3	0.5	$V_{max}/\sqrt{2}$	V_{max}	$V_{max}/\sqrt{2}$	0.5	0.3	0.15	0.03
f [kHz]					f_{c1}	f_0	f_{c2}				
$20\log\left(\frac{V_o}{V_i}\right)$ [dB]											

Part D: Passive Band Reject Filter

For R = 3.5 Ω

Table 9.5

V_o [V _{RMS}]	V_{max}	$V_{max}/\sqrt{2}$	0.5	0.3	0.15	V_{min}	0.15	0.3	0.5	$V_{max}/\sqrt{2}$	V_{max}
f [kHz]		f_{c1}				f_0				f_{c2}	
$20\log\left(\frac{V_o}{V_i}\right)$ [dB]											

For R = 7.1 kΩ

Table 9.6

V_o [V _{RMS}]	V_{max}	$V_{max}/\sqrt{2}$	0.5	0.3	0.15	V_{min}	0.15	0.3	0.5	$V_{max}/\sqrt{2}$	V_{max}
f [kHz]		f_{c1}				f_0				f_{c2}	
$20\log\left(\frac{V_o}{V_i}\right)$ [dB]											

Experiment 10 - Data Tables:

Part A: First order active low pass filter

Table 10.1

f [kHz]	0.03	0.1	1	fc	3	4.5	10	30	100	150
V _o [V _{RMS}]	V _{max}			V _{max} /√2						
20log($\frac{V_o}{V_i}$) [dB]										

Part B: Second Order Low Pass Butterworth Filter

Table 10.2

f [kHz]	0.1	0.3	1	1.3	fc	2	3	4.5	10	30
V _o [V _{RMS}]	V _{max}				V _{max} /√2					
20log($\frac{V_o}{V_i}$) [dB]										

Part C: First order active high pass filter

Table 10.3

f [kHz]	0.03	0.1	0.3	0.6	0.75	1	fc	3	6	10
V _o [V _{RMS}]							V _{max} /√2			V _{max}
20log($\frac{V_o}{V_i}$) [dB]										

Part D: Second Order High Pass Butterworth Filter

Table 10.4

f [kHz]	0.1	0.3	0.6	0.8	1	1.25	f_c	2	3	10
V_o [V_{RMS}]							$V_{\max}/\sqrt{2}$			V_{\max}
$20\log\left(\frac{V_o}{V_i}\right)$ [dB]										

Part E: Active band-pass filters

Table 10.5

V_o [V_{RMS}]	0.05	0.25	0.5	0.75	$V_{\max}/\sqrt{2}$	V_{\max}	$V_{\max}/\sqrt{2}$	0.75	0.5	0.25	0.05
f [kHz]					f_{c1}	f₀	f_{c2}				
$20\log\left(\frac{V_o}{V_i}\right)$ [dB]											

Part F: Active band-reject filter

Table 10.6

V_o [V_{RMS}]	V_{\max}	$V_{\max}/\sqrt{2}$	0.5	0.3		V_{\min}		0.3	0.5	$V_{\max}/\sqrt{2}$	V_{\max}
f [kHz]		f_{c1}				f₀				f_{c2}	
$20\log\left(\frac{V_o}{V_i}\right)$ [dB]											

Experiment 11 - Data Tables:

Table 11.1

Input conditions		Measure		Calculate	
$V_1 = 10 \text{ V}$	$I_2 = 0$	$I_1 =$	$V_2 =$	$Z_{11} =$	$Z_{21} =$
$I_1 = 0$	$V_2 = 10 \text{ V}$	$V_1 =$	$I_2 =$	$Z_{12} =$	$Z_{22} =$

Table 11.2

Input conditions		Measure		Calculate	
$V_1 = 5 \text{ V}$	$I_2 = 0$	$I_1 =$	$V_2 =$	$Z_{11} =$	$Z_{21} =$
$I_1 = 0$	$V_2 = 5 \text{ V}$	$V_1 =$	$I_2 =$	$Z_{12} =$	$Z_{22} =$

Table 11.3

Input conditions		Measure		Calculate	
$V_1 = 10 \text{ V}$	$I_2 = 0$	$I_1 =$	$V_2 =$	$Z_{11} =$	$Z_{21} =$
$I_1 = 0$	$V_2 = 10 \text{ V}$	$V_1 =$	$I_2 =$	$Z_{12} =$	$Z_{22} =$

Table 11.4

Input conditions		Measure		Calculate	
$V_1 = 4 V_{RMS}$	$I_2 = 0$	$I_1 =$	$V_2 =$	$a_{11} =$	$a_{21} =$
$V_1 = 4 V_{RMS}$	$V_2 = 0$	$I_1 =$	$I_2 =$	$a_{12} =$	$a_{22} =$

Table 11.5

Input conditions		Measure		Calculate	
$V_1 = 4 V_{RMS}$	$I_2 = 0$	$I_1 =$	$V_2 =$	$a_{11} =$	$a_{21} =$
$V_1 = 4 V_{RMS}$	$V_2 = 0$	$I_1 =$	$I_2 =$	$a_{12} =$	$a_{22} =$

Table 11.6

Input conditions		Measure		Calculate	
$V_1 = 4 V_{RMS}$	$I_2 = 0$	$I_1 =$	$V_2 =$	$a_{11} =$	$a_{21} =$
$V_1 = 4 V_{RMS}$	$V_2 = 0$	$I_1 =$	$I_2 =$	$a_{12} =$	$a_{22} =$