



**Electrical Engineering Department  
Prelab7**

**Student Name: abed.hmeadan      Id:1161306**

**Instructor: Dr.Mohammed jubran      section:1**

T.A :Eng dalal hamdan

Date:12/10/2018

## Part A: Impedance Measurement

1. For the circuits shown in Figures 7.7 - 7.10 calculate the magnitude of the impedances  $Z_R$ ,  $Z_C$ ,  $Z_L$ , and  $Z_{RC}$  respectively, for the following frequencies: 250, 500, 1000 and 2000 Hz.

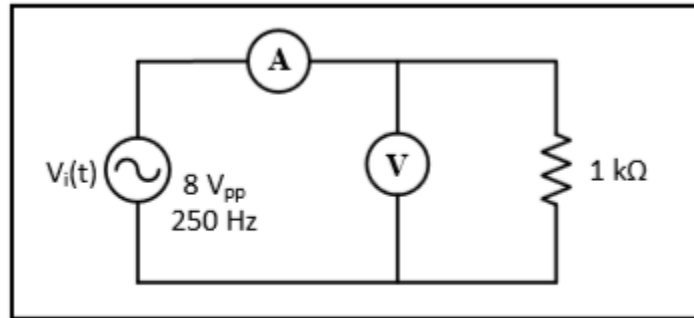

Figure 7.7

$$Z_R = 1 \text{ k}\Omega$$

at any frequency(constant)

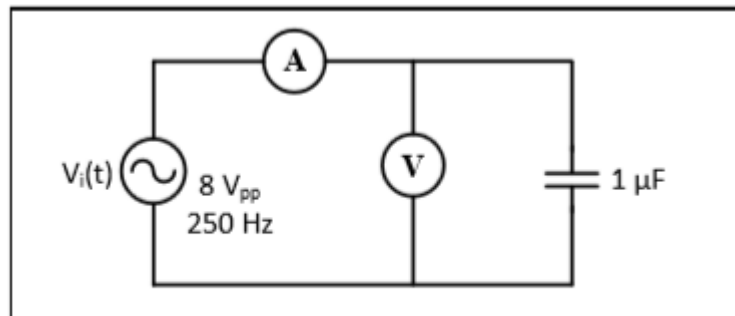

Figure 7.8

$$Z_c = 1/\omega c = 1/(250 * 2 * \pi * 1 * 10^{-6}) = 636.6 \Omega \quad f = 250 \text{ Hz}$$

$$Z_c = 1/(500 * 2 * \pi * 10^{-6}) = 318.3 \Omega \quad f = 500 \text{ Hz}$$

$$Z_c = 1/(1000 * 2 * \pi * 10^{-6}) = 159.2 \Omega \quad f = 1000 \text{ Hz}$$

$$Z_c = 1/(2000 * 2 * \pi * 10^{-6}) = 79.6 \Omega \quad f = 2000 \text{ Hz}$$

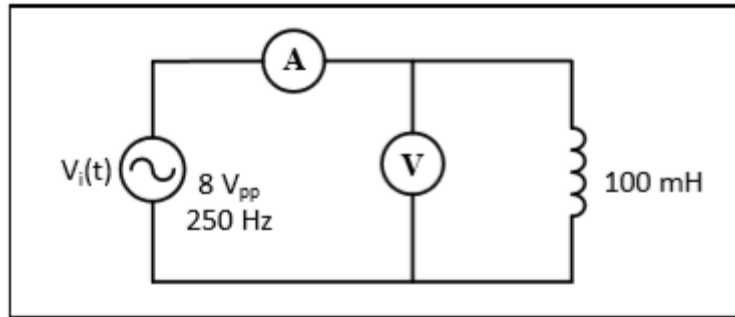

Figure 7.9

$$Z_L = \omega * L = 2 * \pi * 250 * 0.1 = 157 \Omega \quad f=250 \text{ Hz}$$

$$Z_L = \omega * L = 2 * \pi * 500 * 0.1 = 314 \Omega \quad f=500 \text{ Hz}$$

$$Z_L = \omega * L = 2 * \pi * 1000 * 0.1 = 628 \Omega \quad f=1000 \text{ Hz}$$

$$Z_L = \omega * L = 2 * \pi * 2000 * 0.1 = 1256 \Omega \quad f=2000 \text{ Hz}$$

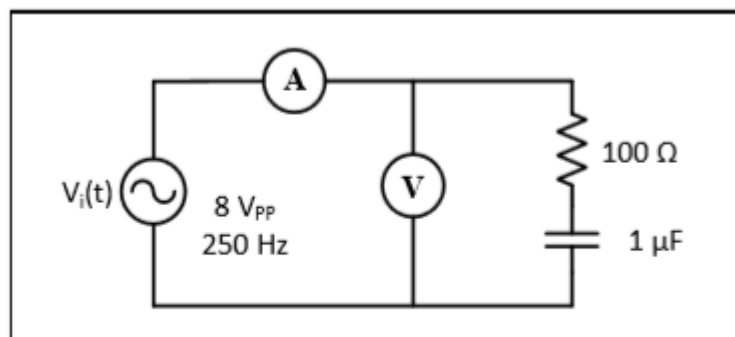

Figure 7.10

$$Z_R = 100 \Omega \text{ (do not be affected by frequency)}$$

$$Z_{RC} = \sqrt{(Z_R^2 + Z_C^2)}$$

$$Z_{RC} = \sqrt{(100^2 + 636.6^2)} = 644 \Omega \quad f=250\text{Hz}$$

$$Z_{RC} = \sqrt{(100^2 + 318.3^2)} = 333.6 \Omega \quad f=500\text{Hz}$$

$$Z_{RC} = \sqrt{(100^2 + 159.1^2)} = 188 \Omega \quad f=1000\text{Hz}$$

$$Z_{RC} = \sqrt{(100^2 + 79.5^2)} = 127 \Omega \quad f=2000\text{Hz}$$

## Part B: Phase Measurement

1. For the circuit shown in Figure 7.11
  - a. Use PSpICE to do transient analysis of the circuit, show  $V_{in}(t)$  and  $V_R(t)$  on one plot

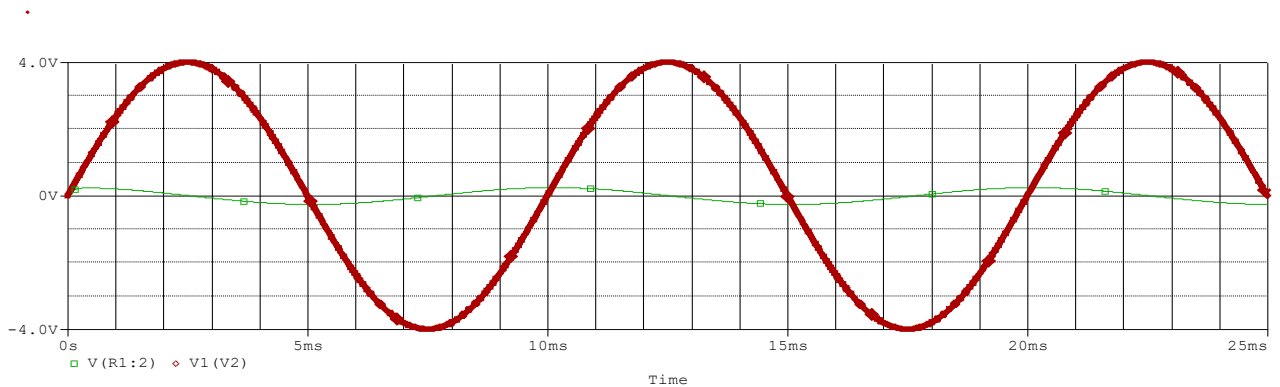
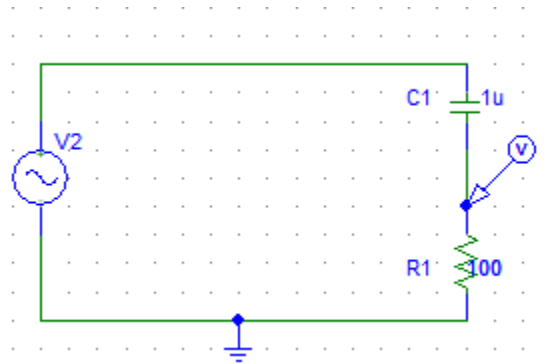

- b. Use cursors to measure the time difference between the peaks of the two signals, then use the following relationship to calculate the phase shift using the measured time  $\{\Delta\theta = 360^\circ \times f \times \Delta t\}$ .

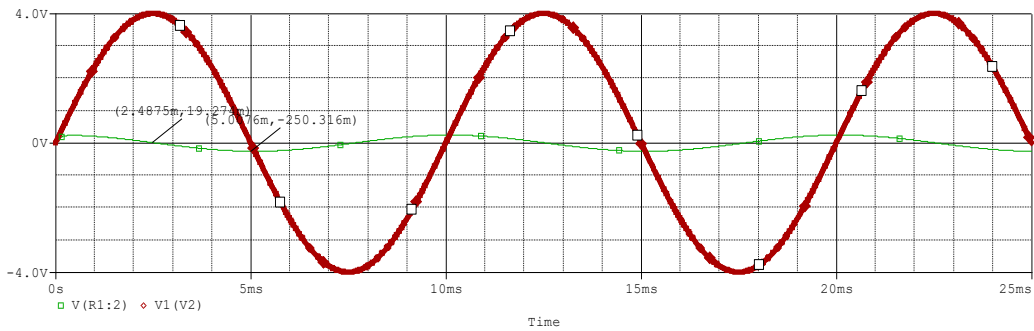

From the figure above

$$\Delta t = (5 - 7.5) \text{ms} = -2.5 \text{ms}$$

$$\Delta \theta = 360 * f * \Delta t = 360 * 100 * 2.5 * 10^{-3} = -90^\circ$$

Repeat the same procedure in step 1 above for the circuit shown in Figure 7.12

- a. Use PSpice to do transient analysis of the circuit, show  $V_{in}(t)$  and  $V_R(t)$  on one plot

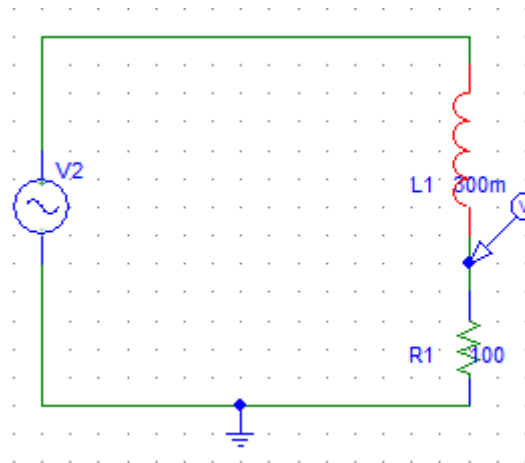

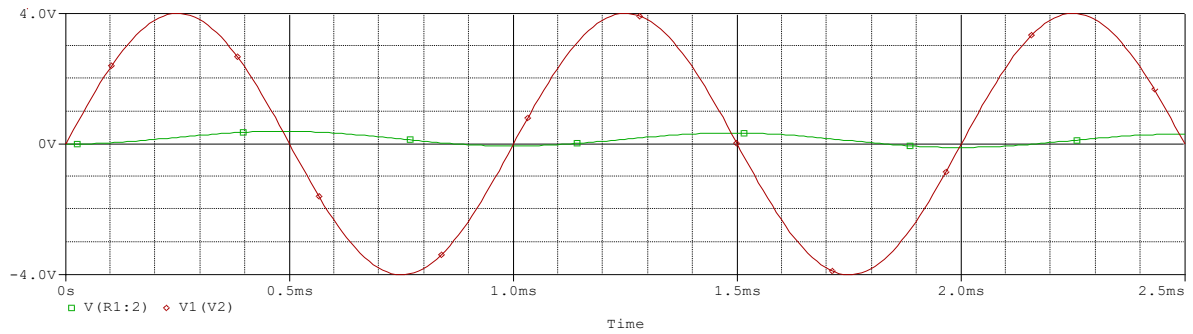

b. Use cursors to measure the time difference between the peaks of the two signals, then use the following relationship to calculate the phase shift using the measured time  $\{\Delta\theta = 360^\circ \times f \times \Delta t\}$ .

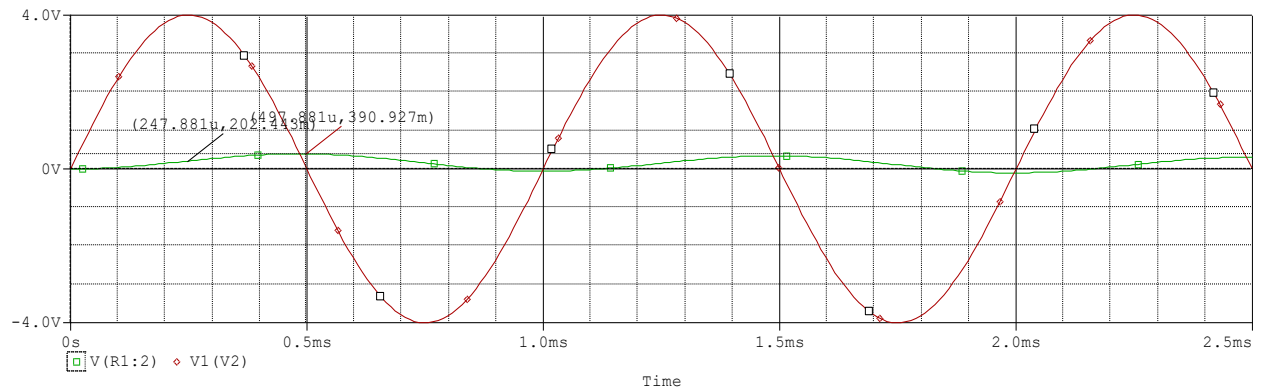

From the figure above

$$\Delta t = (0.5 - 0.25) \text{ms} = 0.25 \text{ms}$$

$$\Delta\theta = 360 \times f \times \Delta t = 360 \times 1000 \times 0.25 \times 10^{-3} = 90^\circ$$