

CH4 Homework Problems

part2

D 4.116 In the circuit of Fig. P4.116, v_{sig} is a small sine-wave signal with zero average. The transistor β is 100.

- Find the value of R_E to establish a dc emitter current of about 0.5 mA.
- Find R_C to establish a dc collector voltage of about +5 V.
- For $R_L = 10 \text{ k}\Omega$ and the transistor $r_o = 200 \text{ k}\Omega$, draw the small-signal equivalent circuit of the amplifier and determine its overall voltage gain.

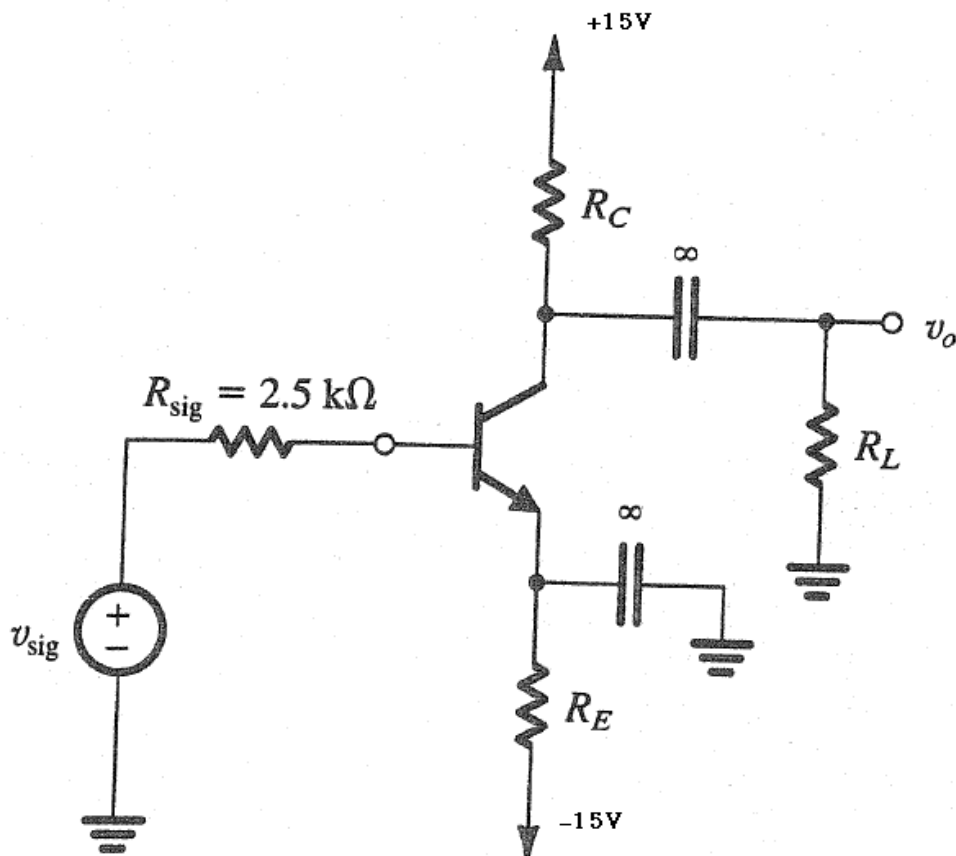

Figure P4.116

***4.119** The BJT in the circuit of Fig. P4.119 has $\beta = 100$.

- Find the dc collector current and the dc voltage at the collector.
- Replacing the transistor by its T model, draw the small-signal equivalent circuit of the amplifier. Analyze the resulting circuit to determine the voltage gain v_o/v_i .

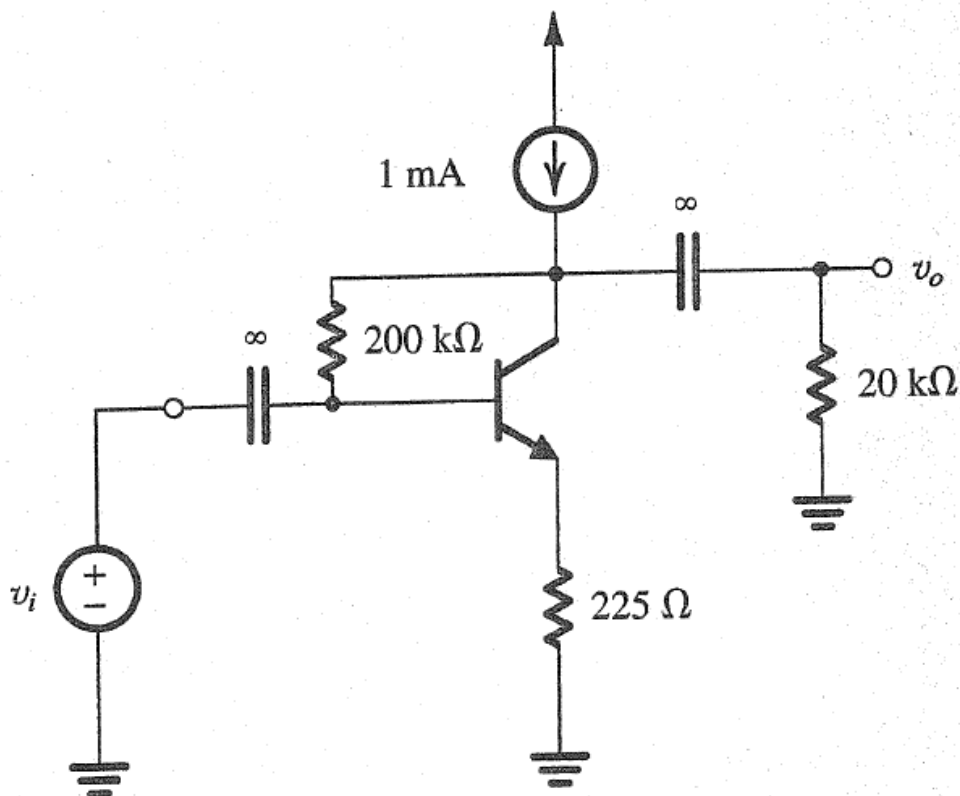

Figure P4.119

4.121 For the circuit in Fig. P4.121, find the input resistance R_{in} and the voltage gain v_o/v_{sig} . Assume that the source provides a small signal v_{sig} and that $\beta = 100$.

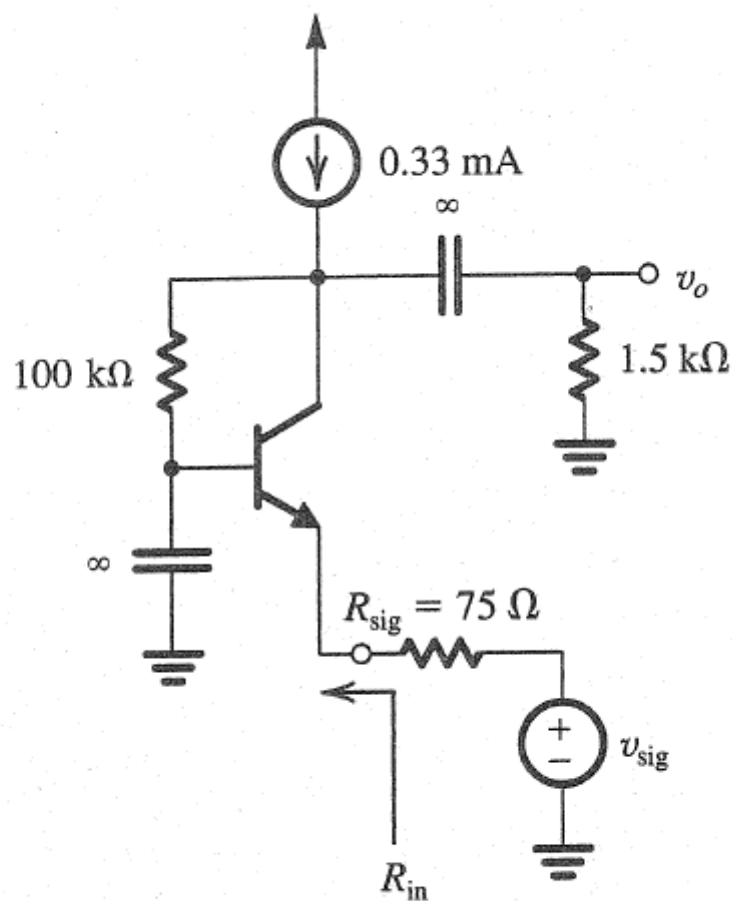

Figure P4.121

****4.124** For the follower circuit in Fig. P4.124, let transistor Q_1 have $\beta = 50$ and transistor Q_2 have $\beta = 100$, and neglect the effect of r_o . Use $V_{BE} = 0.7$ V.

(a) Find the dc emitter currents of Q_1 and Q_2 . Also, find the dc voltages V_{B1} and V_{B2} .

(b) If a load resistance $R_L = 1$ k Ω is connected to the output terminal, find the voltage gain from the base to the emitter of Q_2 , v_o/v_{b2} , and find the input resistance R_{ib2} looking into the base of Q_2 . (*Hint: Consider Q_2 as an emitter follower fed by a voltage v_{b2} at its base.*)

(c) Replacing Q_2 with its input resistance R_{ib2} found in (b), analyze the circuit of emitter follower Q_1 to determine its input resistance R_{in} , and the gain from its base to its emitter, v_{e1}/v_{b1} .

(d) If the circuit is fed with a source having a 100-k Ω resistance, find the transmission to the base of Q_1 , v_{b1}/v_{sig} .

(e) Find the overall voltage gain v_o/v_{sig} .

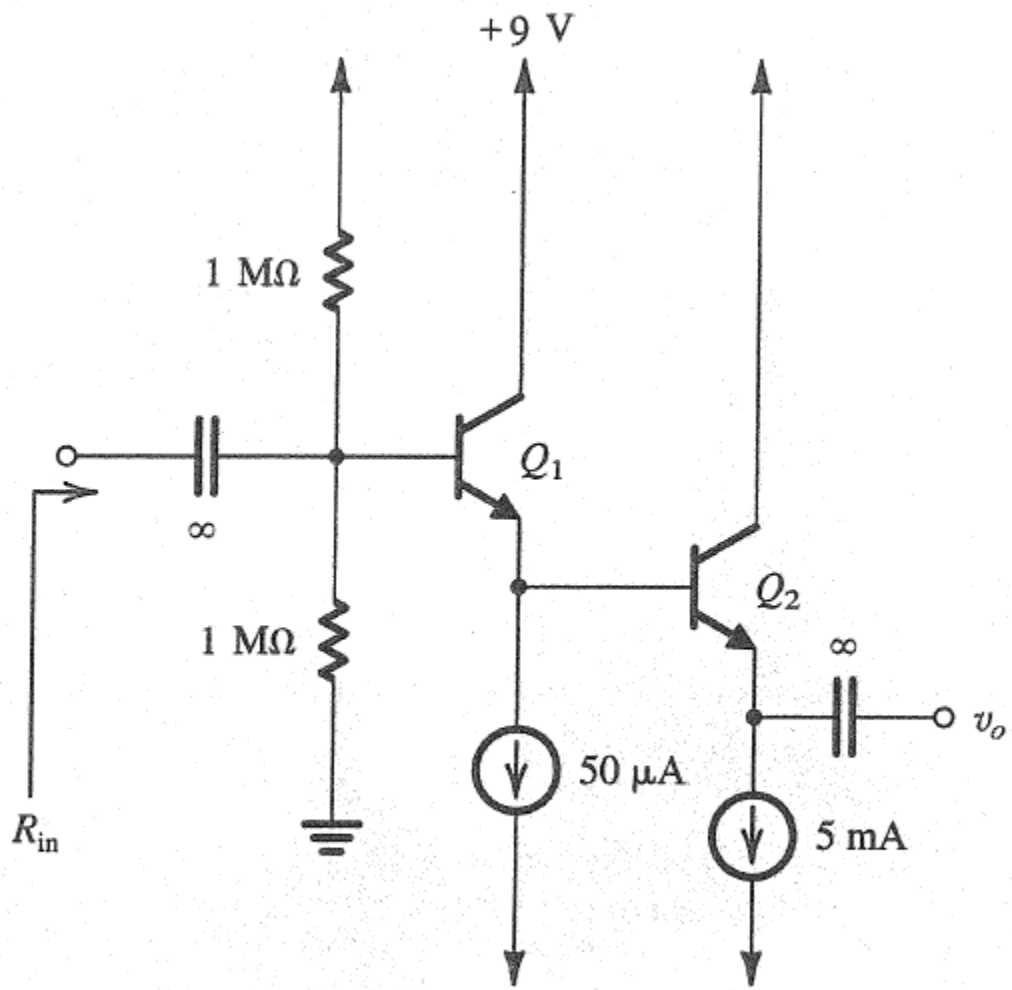

Figure P4.124