

ENEE233 CH5 Homework Problems

D 5.30 Design the circuit of Fig. 5.21 to establish a drain current of 1 mA and a drain voltage of 0 V. The MOSFET has $V_t = 1$ V, $\mu_n C_{ox} = 60 \mu\text{A}/\text{V}^2$, $L = 3 \mu\text{m}$, and $W = 100 \mu\text{m}$.

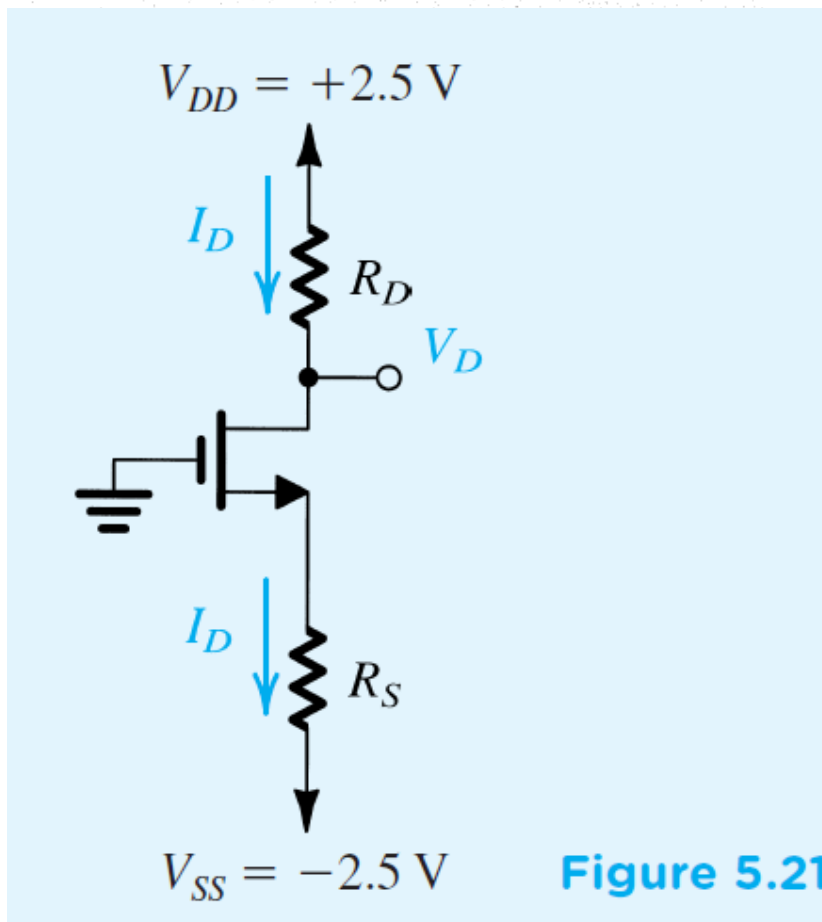

D 5.33 The NMOS transistors in the circuit of Fig. P5.33 have $V_t = 0.5$ V, $\mu_n C_{ox} = 250$ $\mu\text{A}/\text{V}^2$, $\lambda = 0$, and $L_1 = L_2 = 0.25$ μm . Find the required values of gate width for each of Q_1 and Q_2 , and the value of R , to obtain the voltage and current values indicated.

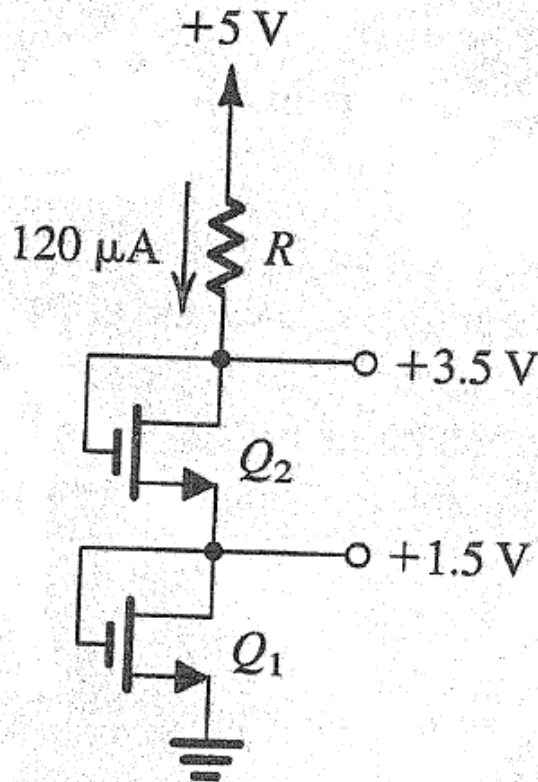

Figure P5.33

5.54 In the circuit of Fig. P5.54, the NMOS transistor has $|V_t| = 0.9$ V and $V_A = 50$ V and operates with $V_D = 2$ V. What is the voltage gain v_o/v_i ? What do V_D and the gain become for I increased to 1 mA?

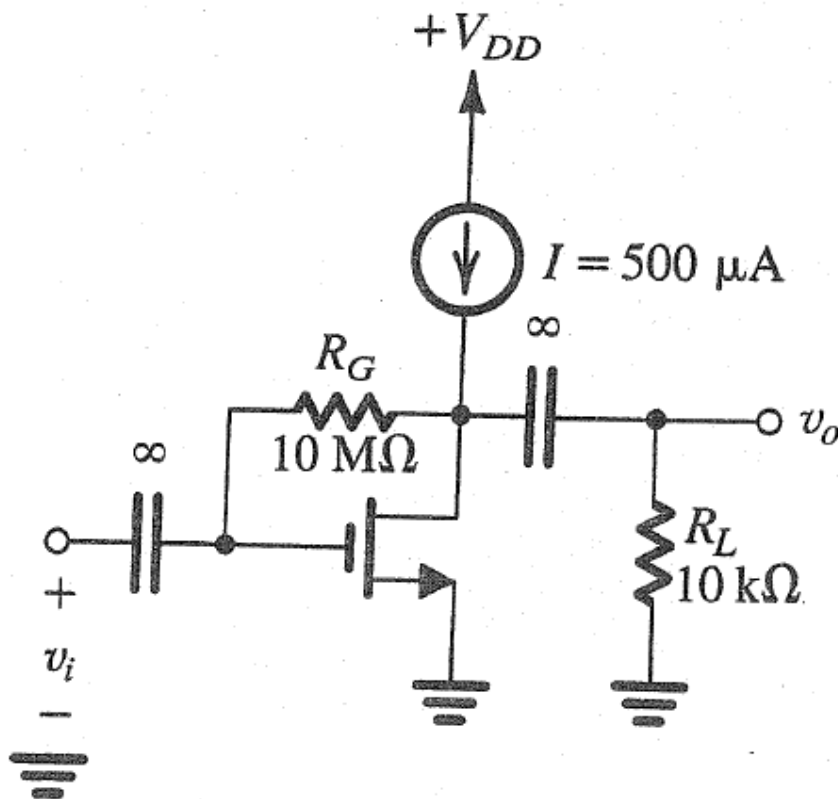

Figure P5.54

D *5.82 The MOSFET in the circuit of Fig. P5.82 has $V_t = 1$ V, $k_n' W/L = 0.8$ mA/V², and $V_A = 40$ V.

- (a) Find the values of R_S , R_D , and R_G so that $I_D = 0.1$ mA, the largest possible value for R_D is used while a maximum signal swing at the drain of ± 1 V is possible, and the input resistance at the gate is 10 M Ω .
- (b) Find the values of g_m and r_o at the bias point.
- (c) If terminal Z is grounded, terminal X is connected to a signal source having a resistance of 1 M Ω , and terminal Y is connected to a load resistance of 40 k Ω , find the voltage gain from signal source to load.
- (d) If terminal Y is grounded, find the voltage gain from X to Z with Z open-circuited. What is the output resistance of the source follower?
- (e) If terminal X is grounded and terminal Z is connected to a current source delivering a signal current of 10 μ A and having a resistance of 100 k Ω , find the voltage signal that can be measured at Y. For simplicity, neglect the effect of r_o .

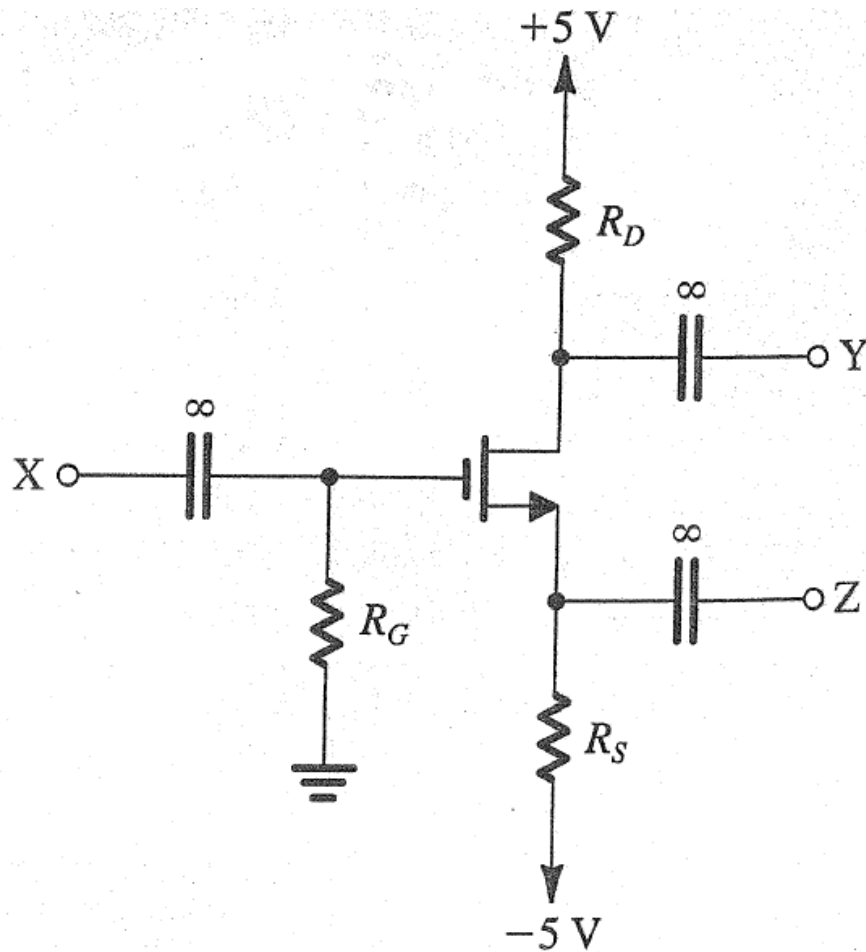
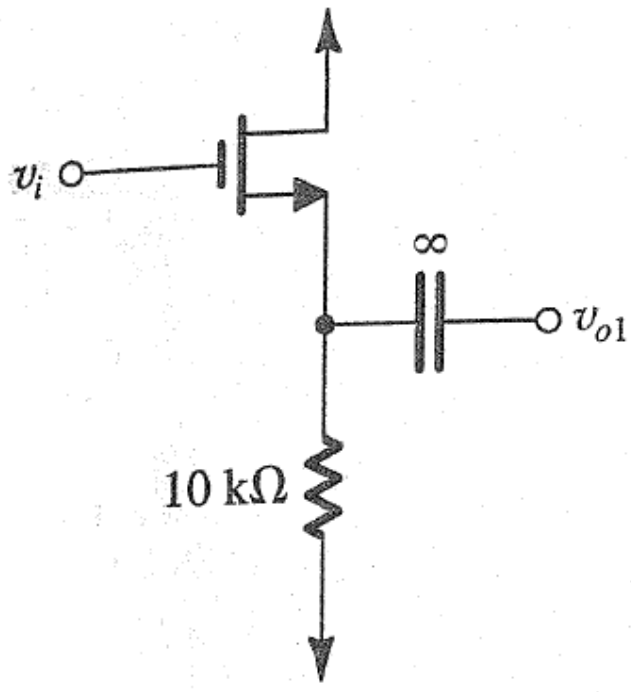
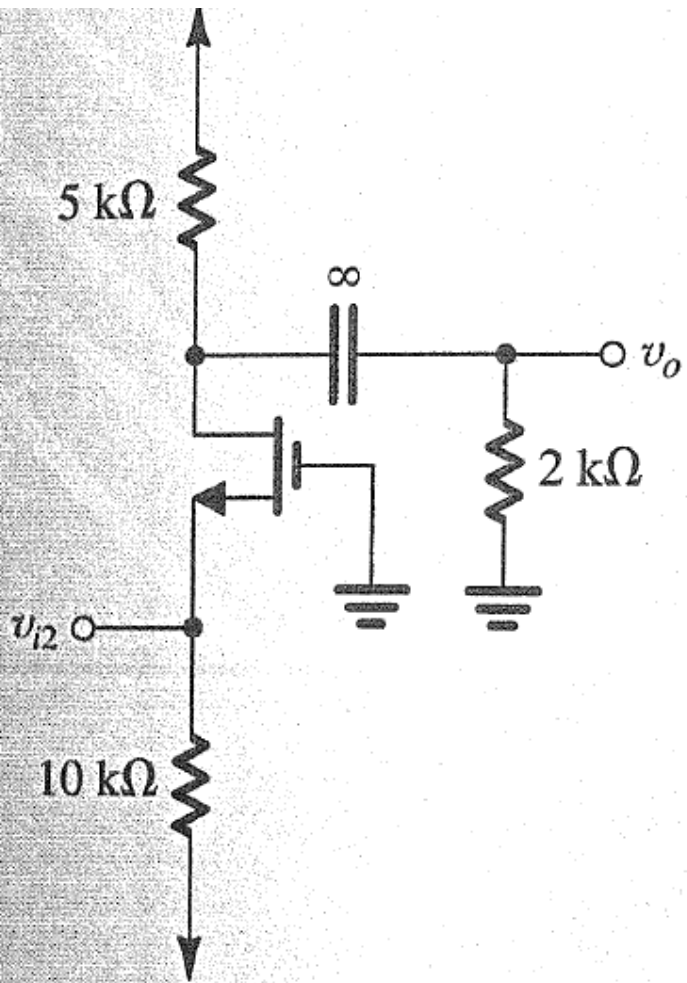

Figure P5.82

- *5.83 (a) The NMOS transistor in the source-follower circuit of Fig. P5.83(a) has $g_m = 5 \text{ mA/V}$ and a large r_o . Find the open-circuit voltage gain and the output resistance.
- (b) The NMOS transistor in the common-gate amplifier of Fig. P5.83(b) has $g_m = 5 \text{ mA/V}$ and a large r_o . Find the input resistance and the voltage gain.
- (c) If the output of the source follower in (a) is connected to the input of the common-gate amplifier in (b), use the results of (a) and (b) to obtain the overall voltage gain v_o/v_i .



(a)



(b)

Figure P5.83