

# **Instructor's Resource Manual to accompany**

## **ELECTRONIC DEVICES, Sixth Edition and ELECTRONIC DEVICES: ELECTRON FLOW VERSION, Fourth Edition**

**Thomas L. Floyd**



Upper Saddle River, New Jersey  
Columbus, Ohio

---

**Copyright © 2002 by Pearson Education, Inc., Upper Saddle River, New Jersey 07458.** All rights reserved. Printed in the United States of America. This publication is protected by Copyright and permission should be obtained from the publisher prior to any prohibited reproduction, storage in a retrieval system, or transmission in any form or by any means, electronic, mechanical, photocopying, recording, or likewise. For information regarding permission(s), write to: Rights and Permissions Department.

Instructors of classes using Floyd, *Electronic Devices, Sixth Edition*, and *Electronic Devices: Electron Flow Version, Fourth Edition*, may reproduce material from the instructor's resource manual for classroom use.

10 9 8 7 6 5 4 3 2 1



ISBN 0-13-092257-9

# Contents

## Solutions for End-of-Chapter Problems

<b>Chapter 1</b>	<b>3</b>
<b>Chapter 2</b>	<b>6</b>
<b>Chapter 3</b>	<b>18</b>
<b>Chapter 4</b>	<b>26</b>
<b>Chapter 5</b>	<b>35</b>
<b>Chapter 6</b>	<b>46</b>
<b>Chapter 7</b>	<b>61</b>
<b>Chapter 8</b>	<b>72</b>
<b>Chapter 9</b>	<b>79</b>
<b>Chapter 10</b>	<b>87</b>
<b>Chapter 11</b>	<b>100</b>
<b>Chapter 12</b>	<b>107</b>
<b>Chapter 13</b>	<b>119</b>
<b>Chapter 14</b>	<b>126</b>
<b>Chapter 15</b>	<b>134</b>
<b>Chapter 16</b>	<b>140</b>
<b>Chapter 17</b>	<b>145</b>
<b>Chapter 18</b>	<b>151</b>
<b>Results for System Applications</b>	<b>157</b>
<b>Summary of EWB/Multisim Circuit Files</b>	<b>167</b>
<b>Test Item File</b>	<b>185</b>



# Chapter 1

## Introduction

---

### *Section 1-1 Atomic Structure*

1. An atom with an atomic number of 6 has **6 electrons** and **6 protons**
2. The third shell of an atom can have  $2n^2 = 2(3)^2 = 18$  **electrons**

### *Section 1-2 Semiconductors, Conductors, and Insulators*

3. The materials represented in Figure 1-40 in the textbook are  
(a) insulator                      (b) semiconductor                      (c) conductor
4. An atom with four valence electrons is a **semiconductor**.

### *Section 1-3 Covalent Bonds*

5. In a silicon crystal, each atom forms **four** covalent bonds.

### *Section 1-4 Conduction in Semiconductors*

6. When heat is added to silicon, more free electrons and holes are produced.
7. Current is produced in silicon at the **conduction** band and the **valence** band.

### *Section 1-5 N-Type and P-Type Semiconductors*

8. Doping is the carefully controlled addition of trivalent or pentavalent atoms to pure (intrinsic) semiconductor material for the purpose of increasing the number of majority carriers (free electrons or holes).
9. Antimony is a pentavalent (donor) material used for doping to increase free electrons. Boron is a trivalent (acceptor) material used for doping to increase the holes.

### *Section 1-6 The Diode*

10. The electric field across the *pn* junction of a diode is created by donor atoms in the *n* region losing free electrons to acceptor atoms in the *p* region. This creates positive ions in the *n*-region near the junction and negative ions in the *p* region near the junction. A field is then established between the ions.
11. The barrier potential of a diode represents an energy gradient that must be overcome by conduction electrons and produces a voltage drop, not a source of energy.

# Chapter 1

---

## *Section 1-7 Biasing the Diode*

12. To forward-bias a diode, the positive terminal of a voltage source must be connected to the **p region**.
13. A series resistor is needed to **limit the current** through a forward-biased diode to a value which will not damage the diode because the diode itself has very little resistance.

## *Section 1-8 Voltage-Current Characteristic of a Diode*

14. To generate the forward bias portion of the characteristic curve, connect a voltage source across the diode for forward bias, and place an ammeter in series with the diode and a voltmeter across the diode. Slowly increase the voltage from zero and plot the forward voltage versus the current.
15. A temperature increase would cause the barrier potential to decrease from 0.7 V to 0.6 V.

## *Section 1-9 Diode Models*

16. (a) The diode is reverse-biased. (b) The diode is forward-biased.  
(c) The diode is forward-biased. (d) The diode is forward-biased.
17. (a)  $V_R = \left( \frac{50 \text{ M}\Omega}{50 \text{ M}\Omega + 10 \text{ }\Omega} \right) (5 \text{ V} - 8 \text{ V}) \cong -3 \text{ V}$   
(b)  $V_F = 0.7 \text{ V}$   
(c)  $V_F = 0.7 \text{ V}$   
(d)  $V_F = 0.7 \text{ V}$

## *Section 1-10 Testing a Diode*

18. (a) Since  $V_D = 25 \text{ V} = 0.5V_S$ , the diode is **open**.  
(b) The diode is forward-biased but since  $V_D = 15 \text{ V} = V_S$ , the diode is **open**.  
(c) The diode is reverse-biased but since  $V_R = 2.5 \text{ V} = 0.5V_S$ , the diode is **shorted**.  
(d) The diode is reverse-biased and  $V_R = 0 \text{ V}$ . The diode is **operating properly**.
19.  $V_A = V_{S1} = +25 \text{ V}$   
 $V_B = V_{S1} - 0.7 \text{ V} = 25 \text{ V} - 0.7 \text{ V} = +24.3 \text{ V}$   
 $V_C = V_{S2} + 0.7 \text{ V} = 8 \text{ V} + 0.7 \text{ V} = +8.7 \text{ V}$   
 $V_D = V_{S2} = +8.0 \text{ V}$

## **EWB/Multisim Troubleshooting Problems**

The solutions showing instrument connections for problems 20 through 28 are available in the Solutions folder for Chapter 1 on the CD-ROM provided with the textbook. The solutions may be accessed using the password *ED5FLOYD*. The faults in the circuit files may be accessed using the password *book* (all lowercase).

- 20. Diode shorted
- 21. Diode open
- 22. Diode open
- 23. Diode shorted
- 24. No fault
- 25. Diode shorted
- 26. Diode leaky
- 27. Diode open
- 28. Diode shorted

# Chapter 2

## Diode Applications

---

### Section 2-1 Half-Wave Rectifiers

1. See Figure 2-1.

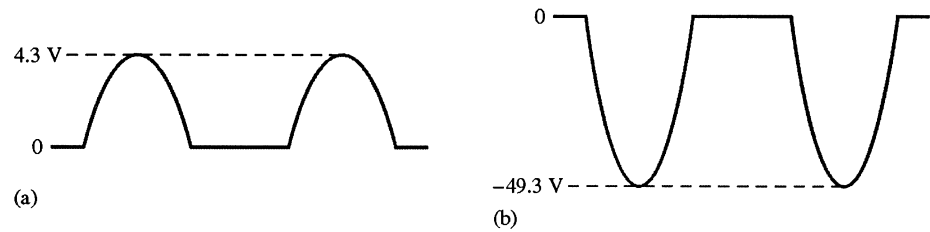

Figure 2-1

2. (a) 
$$I_F = \frac{V_{(p)in} - 0.7 \text{ V}}{R} = \frac{5 \text{ V} - 0.7 \text{ V}}{47 \Omega} = \frac{4.3 \text{ V}}{47 \Omega} = 91.5 \text{ mA}$$

(b) 
$$I_F = \frac{V_{(p)in} - 0.7 \text{ V}}{R} = \frac{50 \text{ V} - 0.7 \text{ V}}{3.3 \text{ k}\Omega} = \frac{49.3 \text{ V}}{3.3 \text{ k}\Omega} = 14.9 \text{ mA}$$

3. 
$$V_{sec} = nV_{pri} = (0.2)115 \text{ V} = 23 \text{ V rms}$$

4. 
$$V_{sec} = nV_{pri} = (0.5)115 \text{ V} = 57.5 \text{ V rms}$$

$$V_{p(sec)} = 1.414(57.5 \text{ V}) = 81.3 \text{ V}$$

$$V_{avg(sec)} = \frac{V_{p(sec)}}{\pi} = \frac{81.3 \text{ V}}{\pi} = 25.9 \text{ V}$$

$$P_{L(p)} = \frac{(V_{p(sec)} - 0.7 \text{ V})^2}{R_L} = \frac{(80.6 \text{ V})^2}{220 \Omega} = 29.5 \text{ W}$$

$$P_{L(avg)} = \frac{(V_{avg(sec)})^2}{R_L} = \frac{(25.9 \text{ V})^2}{220 \Omega} = 3.05 \text{ W}$$

### Section 2-2 Full-Wave Rectifiers

5. (a) 
$$V_{avg} = \frac{V_p}{\pi} = \frac{5 \text{ V}}{\pi} = 1.59 \text{ V}$$

(b) 
$$V_{avg} = \frac{2V_p}{\pi} = \frac{2(100 \text{ V})}{\pi} = 63.7 \text{ V}$$

(c) 
$$V_{avg} = \frac{2V_p}{\pi} + 10 \text{ V} = \frac{2(10 \text{ V})}{\pi} + 10 \text{ V} = 16.4 \text{ V}$$

(d) 
$$V_{avg} = \frac{2V_p}{\pi} - 15 \text{ V} = \frac{2(40 \text{ V})}{\pi} - 15 \text{ V} = 10.5 \text{ V}$$



6. (a) Center-tapped full-wave rectifier  
 (b)  $V_{p(sec)} = (0.25)(1.414)110 \text{ V} = 38.9 \text{ V}$   
 (c)  $\frac{V_{p(sec)}}{2} = \frac{38.9 \text{ V}}{2} = 19.4 \text{ V}$   
 (d) See Figure 2-2.  $V_{RL} = 19.4 \text{ V} - 0.7 \text{ V} = 18.7 \text{ V}$

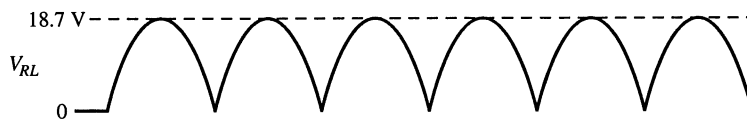

**Figure 2-2**

(e)  $I_F = \frac{\frac{V_{p(sec)}}{2} - 0.7 \text{ V}}{R_L} = \frac{18.7 \text{ V}}{1.0 \text{ k}\Omega} = 18.7 \text{ mA}$

(f)  $\text{PIV} = 19.4 \text{ V} + 18.7 \text{ V} = 38.1 \text{ V}$

7.  $V_{avg} = \frac{110 \text{ V}}{2} = 55 \text{ V}$  for each half

$$V_{avg} = \frac{V_p}{\pi}$$

$$V_p = \pi V_{avg} = \pi(55 \text{ V}) = 173 \text{ V}$$

8. See Figure 2-3.

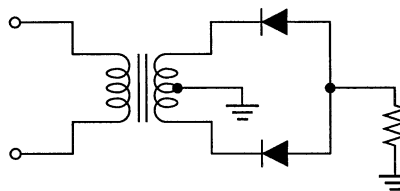
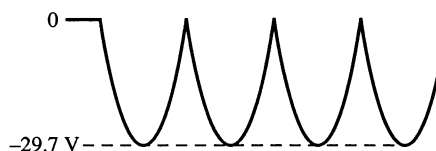

**Figure 2-3**

9.  $\text{PIV} = V_p = \frac{\pi V_{avg(out)}}{2} = \frac{\pi(50 \text{ V})}{2} = 78.5 \text{ V}$

10.  $\text{PIV} = V_{p(out)} = 1.414(20 \text{ V}) = 28.3 \text{ V}$

11. See Figure 2-4.



**Figure 2-4**

## Chapter 2

### Section 2-3 Power Supply Filters and Regulators

12.  $V_{r(pp)} = (1.414)(0.5 \text{ V}) = 707 \text{ mV pp}$

$$r = \frac{V_{r(pp)}}{V_{DC}} = \frac{707 \text{ mV}}{75 \text{ V}} = \mathbf{0.00943}$$

13.  $V_{r(pp)} = \frac{V_{p(in)}}{fR_L C} = \frac{30 \text{ V}}{(120 \text{ Hz})(600 \Omega)(50 \mu\text{F})} = \mathbf{8.33 \text{ V pp}}$

$$V_{DC} = \left(1 - \frac{1}{2fR_L C}\right) V_{p(in)} = \left(1 - \frac{1}{(240 \text{ Hz})(600 \Omega)(50 \mu\text{F})}\right) 30 \text{ V} = \mathbf{25.8 \text{ V}}$$

14.  $\%r = \left(\frac{V_{r(pp)}}{V_{DC}}\right) 100 = \left(\frac{8.33 \text{ V}}{25.8 \text{ V}}\right) 100 = \mathbf{32.3\%}$

15.  $V_{r(pp)} = (0.01)(18 \text{ V}) = 108 \text{ mV}$

$$V_{r(pp)} = \left(\frac{1}{fR_L C}\right) V_{p(in)}$$

$$C = \left(\frac{1}{fR_L V_r}\right) V_{p(in)} = \left(\frac{1}{(120 \text{ Hz})(1.5 \text{ k}\Omega)(180 \text{ mV})}\right) 18 \text{ V} = \mathbf{556 \mu\text{F}}$$

16.  $V_{r(pp)} = \frac{V_{p(in)}}{fR_L C} = \frac{80 \text{ V}}{(120 \text{ Hz})(10 \text{ k}\Omega)(10 \mu\text{F})} = 6.67 \text{ V}$

$$V_{DC} = \left(1 - \frac{1}{2fR_L C}\right) V_{p(in)} = \left(1 - \frac{1}{(240 \text{ Hz})(10 \text{ k}\Omega)(10 \mu\text{F})}\right) 80 \text{ V} = 46.7 \text{ V}$$

$$r = \frac{V_{r(pp)}}{V_{DC}} = \frac{6.67 \text{ V}}{46.7 \text{ V}} = \mathbf{0.143}$$

17.  $V_{p(sec)} = (1.414)(36 \text{ V}) = 50.9 \text{ V}$

$$V_{r(rect)} = V_{p(sec)} - 1.4 \text{ V} = 50.9 \text{ V} - 1.4 \text{ V} = 49.5 \text{ V}$$

$$\text{Neglecting } R_{surge}, V_{r(pp)} = \left(\frac{1}{fR_L C}\right) V_{p(rect)} = \left[\frac{1}{(120 \text{ Hz})(3.3 \text{ k}\Omega)(100 \mu\text{F})}\right] 49.5 \text{ V} = \mathbf{1.25 \text{ V}}$$

$$V_{DC} = \left(1 - \frac{1}{2fR_L C}\right) V_{p(rect)} = V_{p(rect)} - \frac{V_{r(pp)}}{2} = 49.5 \text{ V} - 0.625 \text{ V} = \mathbf{48.9 \text{ V}}$$

18.  $V_{p(sec)} = 1.414(36 \text{ V}) = 50.9 \text{ V}$   
See Figure 2-5.

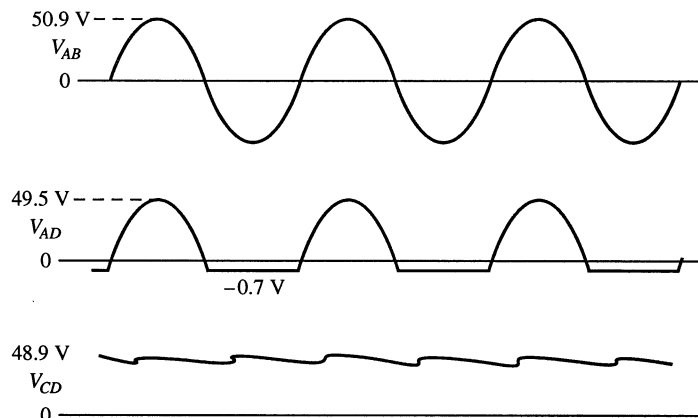

Figure 2-5

19. Load regulation =  $\left( \frac{V_{NL} - V_{FL}}{V_{FL}} \right) 100\% = \left( \frac{15.5 \text{ V} - 14.9 \text{ V}}{14.9 \text{ V}} \right) 100\% = 4\%$
20.  $V_{FL} = V_{NL} - (0.005)V_{NL} = 12 \text{ V} - (0.005)12 \text{ V} = 11.94 \text{ V}$

### Section 2-4 Diode Limiting and Clamping Circuits

21. See Figure 2-6.

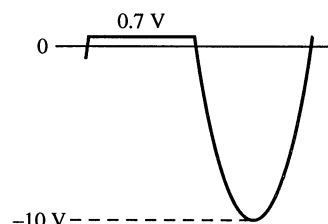

Figure 2-6

22. Apply Kirchhoff's law at the peak of the positive half cycle:

$$\begin{aligned} \text{(b)} \quad 25 \text{ V} &= V_R + V_R + 0.7 \text{ V} \\ 2V_R &= 24.3 \text{ V} \\ V_R &= \frac{24.3 \text{ V}}{2} = 12.15 \text{ V} \\ V_{out} &= V_R + 0.7 \text{ V} = 12.15 \text{ V} + 0.7 \text{ V} = 12.85 \text{ V} \\ &\text{See Figure 2-7(a).} \end{aligned}$$

$$\begin{aligned} \text{(c)} \quad V_R &= \frac{11.3 \text{ V}}{2} = 5.65 \text{ V} \\ V_{out} &= V_R + 0.7 \text{ V} = 5.65 \text{ V} + 0.7 \text{ V} = 6.35 \text{ V} \\ &\text{See Figure 2-7(b).} \end{aligned}$$

# Chapter 2

- (d)  $V_R = \frac{4.3 \text{ V}}{2} = 2.15 \text{ V}$   
 $V_{out} = V_R + 0.7 \text{ V} = 2.15 \text{ V} + 0.7 \text{ V} = 2.85 \text{ V}$   
 See Figure 2-7(c).

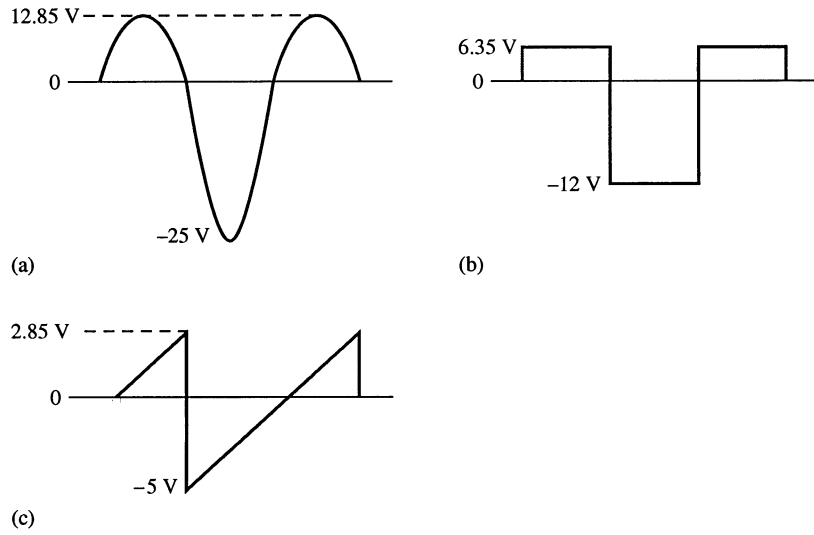

**Figure 2-6**

23. See Figure 2-8.

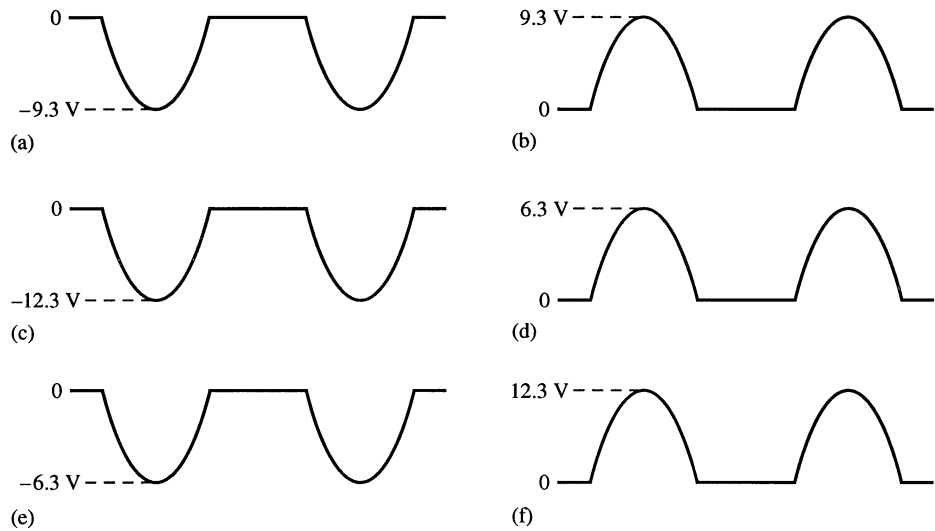

**Figure 2-8**

24. See Figure 2-9.

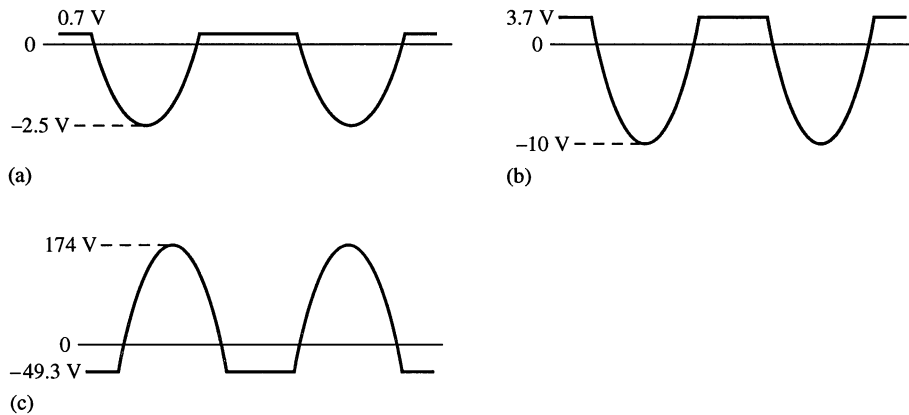

Figure 2-9

25. See Figure 2-10.

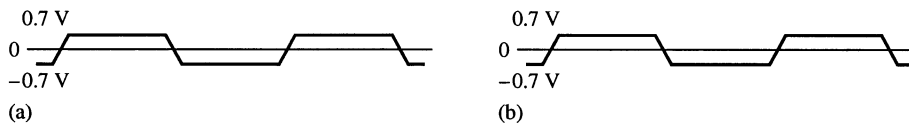

Figure 2-10

26. See Figure 2-11.

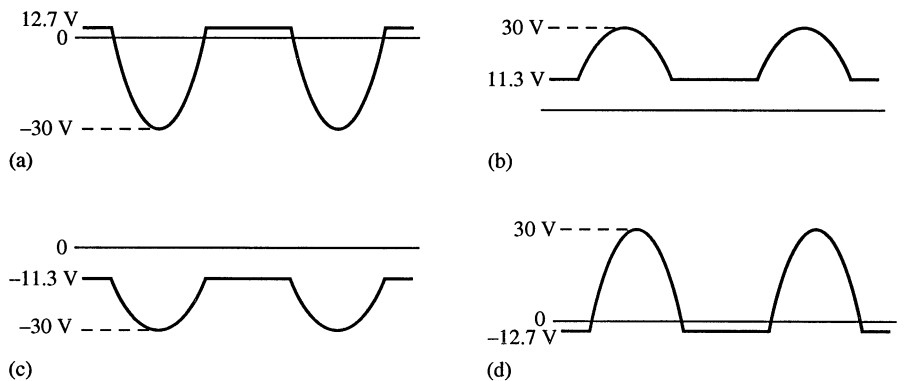

Figure 2-11

27. (a) A sine wave with a positive peak at 0.7 V, a negative peak at  $-7.3$  V, and a dc value of  $-3.3$  V.  
 (b) A sine wave with a positive peak at 29.3 V, a negative peak at  $-0.7$  V, and a dc value of  $+14.3$  V.  
 (c) A square wave varying from  $+0.7$  V to  $-15.3$  V with a dc value of  $-7.3$  V.  
 (d) A square wave varying from  $+1.3$  V to  $-0.7$  V with a dc value of  $+0.3$  V.
28. (a) A sine wave varying from  $-0.7$  V to  $+7.3$  V with a dc value of  $+3.3$  V.  
 (b) A sine wave varying from  $-29.3$  V to  $+7.3$  V with a dc value of  $+14.3$  V.  
 (c) A square wave varying from  $-0.7$  V to  $+15.3$  V with a dc value of  $+7.3$  V.  
 (d) A square wave varying from  $-1.3$  V to  $+0.7$  V with a dc value of  $-0.3$  V.

# Chapter 2

## Section 2-5 Voltage Multipliers

29.  $V_{OUT} = 2V_{p(in)} = 2(1.414)(20\text{ V}) = 56.6\text{ V}$   
See Figure 2-12.

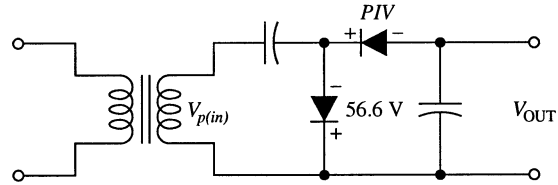
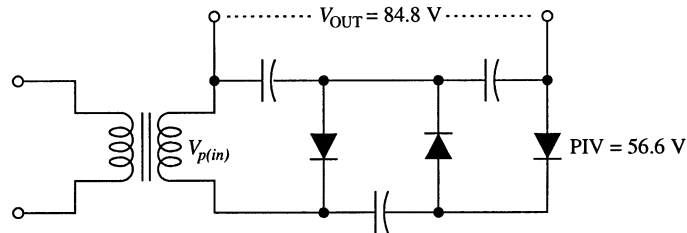
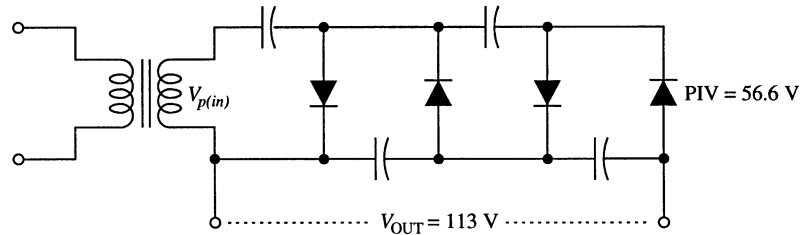

Figure 2-12

30.  $V_{OUT(trip)} = 3V_{p(in)} = 3(1.414)(20\text{ V}) = 84.8\text{ V}$   
 $V_{OUT(quad)} = 4V_{p(in)} = 4(1.414)(20\text{ V}) = 113\text{ V}$   
See Figure 2-13.



(a) Tripler



(b) Quadrupler

Figure 2-13

## Section 2-6 The Diode Data Sheet

31. The PIV is specified as the peak repetitive reverse voltage = 50 V.  
32. The PIV is specified as the peak repetitive reverse voltage = 400 V.  
33. Use the specified  $I_{FSM} = 800\text{ A}$ .

$$R_{surge(min)} = \frac{50\text{ V}}{800\text{ A}} = 6.25\text{ m}\Omega$$

### Section 2-7 Troubleshooting

34. If a bridge rectifier diode opens, the output becomes a half-wave voltage resulting in an increased ripple at 60 Hz.

$$35. \quad V_{avg} = \frac{2V_p}{\pi} = \frac{2(115 \text{ V})(1.414)}{\pi} \cong 104 \text{ V}$$

The output of the bridge is correct. However, the 0 V output from the filter indicates that the **surge resistor is open** or that the **capacitor is shorted**.

36. (a) Correct  
 (b) Incorrect. Open diode.  
 (c) Correct  
 (d) Incorrect. Open diode.

$$37. \quad V_{sec} = \frac{115 \text{ V}}{5} = 23 \text{ V rms}$$

$$V_{p(sec)} = 1.414(23 \text{ V}) = 32.5 \text{ V}$$

The peak voltage for each half of the secondary is

$$\frac{V_{p(sec)}}{2} = \frac{32.5 \text{ V}}{2} = 16.3 \text{ V}$$

The peak inverse voltage for each diode is  $PIV = 2(16.3 \text{ V}) + 0.7 \text{ V} = 33.2 \text{ V}$

The peak current through each diode is

$$I_p = \frac{\frac{V_{p(sec)}}{2} - 0.7 \text{ V}}{R_L} = \frac{16.3 \text{ V} - 0.7 \text{ V}}{330 \Omega} = 47.3 \text{ mA}$$

The diode ratings exceed the actual PIV and peak current.

The circuit should not fail.

### System Application Problems

38. (a) No voltage between TP1 and TP2:  
*Possible causes:* fuse blown or power cord not plugged in.  
*Corrective action:* check fuse and power plug. Replace fuse or insert plug.
- (b) No voltage between TP3 and TP4, 110 V from TP1 to TP2:  
*Possible causes:* open primary or shorted secondary.  
*Corrective action:* check windings with ohmmeter. Replace transformer.
- (c) 50 V between TP3 and TP4, input voltage correct:  
*Possible causes:* partially shorted primary or wrong turns ratio.  
*Corrective action:* check primary winding and transformer rating. Replace transformer.
- (d) 25 V between TP3 and TP4, input voltage correct:  
*Possible causes:* partially shorted secondary or wrong turns ratio.  
*Corrective action:* check secondary winding and transformer rating. Replace transformer.

## Chapter 2

---

- (e) Full-wave voltage with peak of 50 V from TP7 to ground:  
*Possible cause:* Filter capacitor open.  
*Corrective action:* check capacitor with ohmmeter. Replace capacitor.
- (f) Excessive 120 Hz ripple at TP7:  
*Possible causes:* leaky filter capacitor or excessive loading.  
*Corrective action:* check capacitor and load. Replace capacitor or correct load condition.
- (g) 60 Hz ripple at TP7:  
*Possible cause:* open diode in bridge.  
*Corrective action:* check diodes with ohmmeter and replace defective one.
- (h) No voltage at TP7:  
*Possible causes:* open surge resistor, blown fuse, open winding, shorted  $C$ .  
*Corrective action:* check all and replace defective component.
39. Something must be causing a diode to open. Check all the diodes for opens this time. You will most likely find one. The PIV or the maximum surge current must have been exceeded. Excessive PIV could be caused by some shorted primary windings which would produce an excessive secondary voltage. If caused by excessive surge current, a small limiting resistor will have to be placed in series with  $C_1$ .
40. If the top diode in textbook Figure 2-87 were reversed, two forward-biased diodes would be placed in series across the secondary during the negative half-cycle which, most likely, would blow the diodes open and result in no voltage at TP8.

### *Advanced Problems*

41. 
$$V_r = \left( \frac{1}{fR_L C} \right) V_{p(in)}$$
$$C = \left( \frac{1}{fR_L V_r} \right) V_{p(in)} = \left( \frac{1}{(120 \text{ Hz})(3.3 \text{ k}\Omega)(0.5 \text{ V})} \right) 35 \text{ V} = 177 \text{ }\mu\text{F}$$



42. 
$$V_{DC} = \left(1 - \frac{1}{2fR_L C}\right) V_{p(in)}$$

$$\frac{V_{DC}}{V_{p(in)}} = \left(1 - \frac{1}{2fR_L C}\right)$$

$$\frac{1}{2fR_L C} = 1 - \frac{V_{DC}}{V_{p(in)}}$$

$$\frac{1}{2fR_L \left(1 - \frac{V_{DC}}{V_{p(in)}}\right)} = C$$

$$C = \frac{1}{(240 \text{ Hz})(1.0 \text{ k}\Omega)(1 - 0.933)} = \frac{1}{(240 \text{ Hz})(1.0 \text{ k}\Omega)(0.067)} = 62.2 \text{ }\mu\text{F}$$

Then

$$V_r = \left(\frac{1}{fR_L C}\right) V_{p(in)} = \left(\frac{1}{(120 \text{ Hz})(1.0 \text{ k}\Omega)(62.2 \text{ }\mu\text{F})}\right) 15 \text{ V} = 2 \text{ V}$$

43. The capacitor input voltage is

$$V_{p(in)} = (1.414)(24 \text{ V}) - 1.4 \text{ V} = 32.5 \text{ V}$$

$$R_{surge} = \frac{V_{p(in)}}{I_{surge}} = \frac{32.5 \text{ V}}{50 \text{ A}} = 651 \text{ m}\Omega$$

The nearest standard value is 680 mΩ.

44. See Figure 2-14.

The voltage at point A with respect to ground is

$$V_A = 1.414(9 \text{ V}) = 12.7 \text{ V}$$

Therefore,

$$V_B = 12.7 \text{ V} - 0.7 \text{ V} = 12 \text{ V}$$

$$V_r = 0.05 V_B = 0.05(12 \text{ V}) = 0.6 \text{ V peak to peak}$$

$$C = \left(\frac{1}{fR_L V_r}\right) V_B = \left(\frac{1}{(120 \text{ Hz})(680 \text{ }\Omega)(0.6 \text{ V})}\right) 12 \text{ V} = 245 \text{ }\mu\text{F}$$

The nearest standard value is 270 μF.

Let  $R_{surge} = 1.0 \text{ }\Omega$ .

$$I_{surge(max)} = \frac{12 \text{ V}}{1.0 \text{ }\Omega} = 12 \text{ A}$$

$$I_O = \frac{12 \text{ V}}{680 \text{ }\Omega} = 17.6 \text{ mA}$$

$$PIV = 2V_{p(out)} + 0.7 \text{ V} = 24.7 \text{ V}$$

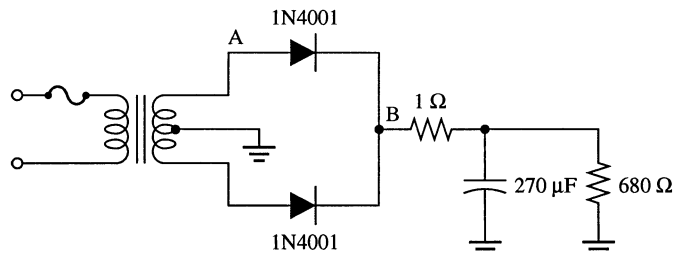

Figure 2-14

## Chapter 2

45. See Figure 2-15.

$$I_{L(max)} = 100 \text{ mA}$$

$$R_L = \frac{9 \text{ V}}{100 \text{ mA}} = 90 \Omega$$

$$V_r = 1.414(0.25 \text{ V}) = 0.354 \text{ V}$$

$$V_r = 2(0.35 \text{ V}) = 0.71 \text{ V peak to peak}$$

$$V_r = \left( \frac{1}{(120 \text{ Hz})(90 \Omega)C} \right) 9 \text{ V}$$

$$C = \frac{9 \text{ V}}{(120 \text{ Hz})(90 \Omega)(0.71 \text{ V})} = 1174 \mu\text{F}$$

Use  $C = 1200 \mu\text{F}$ .

Each half of the supply uses identical components. 1N4001 diodes are feasible since the average current is  $(0.318)(100 \text{ mA}) = 31.8 \text{ mA}$ .

$R_{surge} = 1.0 \Omega$  will limit the surge current to an acceptable value.

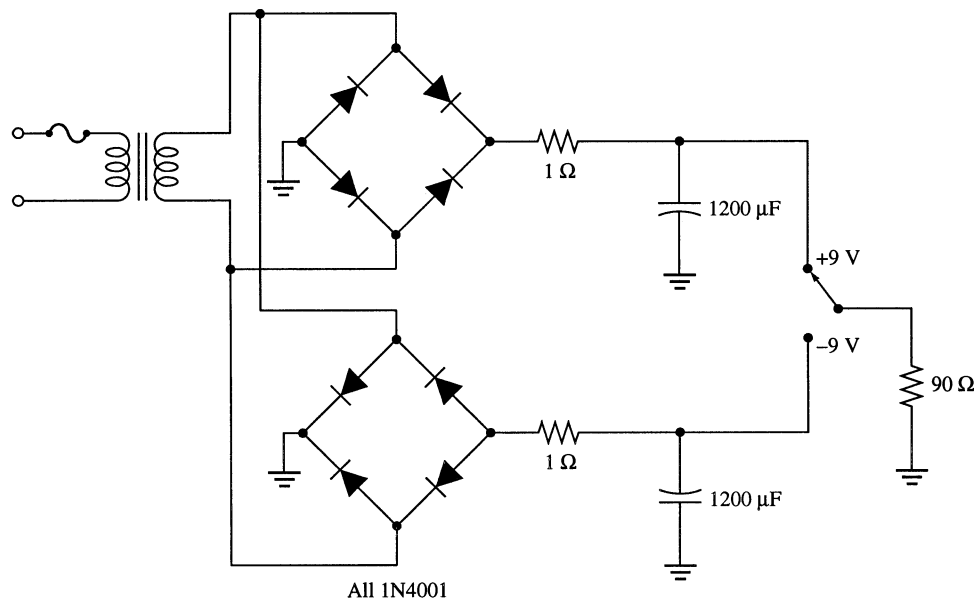

Figure 2-15

46. Both positive and negative limiting of a sinusoidal voltage is not achievable with a single dc source.
47.  $V_{C1} = (1.414)(110 \text{ V}) - 0.7 \text{ V} = 155 \text{ V}$   
 $V_{C2} = 2(1.414)(110 \text{ V}) - 2(0.7 \text{ V}) = 310 \text{ V}$

### **EWB/Multisim Troubleshooting Problems**

The solutions showing instrument connections for Problems 48 through 56 are available in the Solutions folder for Chapter 2 on the CD-ROM provided with the textbook. The solutions may be accessed using the password *ED5FLOYD*. The faults in the circuit files may be accessed using the password *book* (all lowercase).

- 48. Diode shorted
- 49. Diode leaky
- 50. Diode open
- 51. Bottom diode open
- 52. Reduced transformer turns ratio
- 53. Open filter capacitor
- 54. Diode leaky
- 55.  $D_1$  open
- 56. Load resistor open

# Chapter 3

## Special-Purpose Diodes

---

### Section 3-1 Zener Diodes

1. See Figure 3-1.

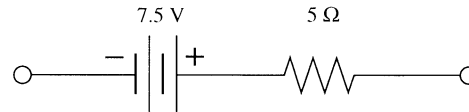

Figure 3-1

2.  $I_{ZK} \cong 3 \text{ mA}$   
 $V_Z \cong -8.5 \text{ V}$

3. 
$$Z_Z = \frac{\Delta V_Z}{\Delta I_Z} = \frac{5.65 \text{ V} - 5.6 \text{ V}}{30 \text{ mA} - 20 \text{ mA}} = \frac{0.05 \text{ V}}{10 \text{ mA}} = 5 \Omega$$

4.  $\Delta I_Z = 50 \text{ mA} - 25 \text{ mA} = 25 \text{ mA}$   
 $\Delta V_Z = \Delta I_Z Z_Z = (+25 \text{ mA})(15 \Omega) = +0.375 \text{ V}$   
 $V_Z = V_{ZT} + \Delta V_Z = 4.7 \text{ V} + 0.375 \text{ V} = \mathbf{5.08 \text{ V}}$

5.  $\Delta T = 70^\circ\text{C} - 25^\circ\text{C} = 45^\circ\text{C}$   

$$V_Z = 6.8 \text{ V} + \frac{(6.8 \text{ V})(0.0004/^\circ\text{C})}{45^\circ\text{C}} = 6.8 \text{ V} + 0.12 \text{ V} = \mathbf{6.92 \text{ V}}$$

### Section 3-2 Zener Diode Applications

6.  $V_{\text{IN}(\text{min})} = V_Z + I_{ZK}R = 14 \text{ V} + (1.5 \text{ mA})(560 \Omega) = \mathbf{14.8 \text{ V}}$
7.  $\Delta V_Z = (I_{ZT} - I_{ZK})Z_Z = (28.5 \text{ mA})(20 \Omega) = 0.57 \text{ V}$   
 $V_{\text{OUT}} = V_{ZT} - \Delta V_Z = 14 \text{ V} - 0.57 \text{ V} = 13.43 \text{ V}$   
 $V_{\text{IN}(\text{min})} = I_{ZK}R + V_{\text{OUT}} = (1.5 \text{ mA})(560 \Omega) + 13.43 \text{ V} = \mathbf{14.3 \text{ V}}$
8.  $\Delta V_Z = I_Z Z_Z = (40 \text{ mA} - 30 \text{ mA})(30 \Omega) = 0.3 \text{ V}$   
 $V_Z = 12 \text{ V} + \Delta V_Z = 12 \text{ V} + 0.3 \text{ V} = 12.3 \text{ V}$   

$$R = \frac{V_{\text{IN}} - V_Z}{40 \text{ mA}} = \frac{18 \text{ V} - 12.3 \text{ V}}{40 \text{ mA}} = \mathbf{143 \Omega}$$

9.  $V_Z \cong 12 \text{ V} + 0.3 \text{ V} = 12.3 \text{ V}$   
See Figure 3-2.

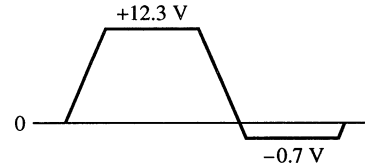

**Figure 3-2**

10.  $V_{Z(\min)} = V_Z - \Delta I_Z Z_Z = 5.1 \text{ V} - (49 \text{ mA} - 1 \text{ mA})(7 \Omega)$   
 $= 5.1 \text{ V} - (48 \text{ mA})(7 \Omega) = 5.1 \text{ V} - 0.336 = 4.76 \text{ V}$   
 $V_R = 8 \text{ V} - 4.76 \text{ V} = 3.24 \text{ V}$   
 $I_T = \frac{V_R}{R} = \frac{3.24 \text{ V}}{22 \Omega} = 147 \text{ mA}$   
 $I_{L(\max)} = 147 \text{ mA} - 1 \text{ mA} = \mathbf{146 \text{ mA}}$   
 $V_{Z(\max)} = 5.1 \text{ V} + (70 \text{ mA} - 49 \text{ mA})(7 \Omega) = 5.1 \text{ V} + 0.34 \text{ V} = 5.44 \text{ V}$   
 $V_R = 8 \text{ V} - 5.44 \text{ V} = 2.56 \text{ V}$   
 $I_T = \frac{2.56 \text{ V}}{22 \Omega} = 116 \text{ mA}$   
 $I_{L(\min)} = 116 \text{ mA} - 70 \text{ mA} = \mathbf{46 \text{ mA}}$
11. % Load regulation =  $\frac{V_{Z(\max)} - V_{Z(\min)}}{V_{Z(\min)}} \times 100\% = \frac{5.44 \text{ V} - 4.76 \text{ V}}{4.76 \text{ V}} \times 100\% = \mathbf{14.3\%}$
12. With no load and  $V_{IN} = 6 \text{ V}$ :  
 $I_Z \cong \frac{V_{IN} - V_Z}{R + Z_Z} = \frac{6 \text{ V} - 5.1 \text{ V}}{29 \Omega} = 31 \text{ mA}$   
 $V_{OUT} = V_Z - \Delta I_Z Z_Z = 5.1 \text{ V} - (35 \text{ mA} - 31 \text{ mA})(7 \Omega) = 5.1 \text{ V} - 0.028 \text{ V} = 5.07 \text{ V}$   
 With no load and  $V_{IN} = 12 \text{ V}$ :  
 $I_Z \cong \frac{V_{IN} - V_Z}{R + Z_Z} = \frac{12 \text{ V} - 5.1 \text{ V}}{29 \Omega} = 238 \text{ mA}$   
 $V_{OUT} = V_Z + \Delta I_Z Z_Z = 5.1 \text{ V} + (238 \text{ mA} - 35 \text{ mA})(7 \Omega) = 5.1 \text{ V} + 1.42 \text{ V} = 6.52 \text{ V}$   
 % Line regulation =  $\frac{\Delta V_{OUT}}{\Delta V_{IN}} \times 100\% = \frac{6.52 \text{ V} - 5.07 \text{ V}}{12 \text{ V} - 6 \text{ V}} \times 100\% = \mathbf{24.2\%}$
13. % Load regulation =  $\frac{V_{NL} - V_{FL}}{V_{FL}} \times 100\% = \frac{8.23 \text{ V} - 7.98 \text{ V}}{7.98 \text{ V}} \times 100\% = \mathbf{3.13\%}$
14. % Line regulation =  $\frac{\Delta V_{OUT}}{\Delta V_{IN}} \times 100\% = \frac{0.2 \text{ V}}{10 \text{ V} - 5 \text{ V}} \times 100\% = \mathbf{4\%}$
15. % Load regulation =  $\frac{V_{NL} - V_{FL}}{V_{FL}} \times 100\% = \frac{3.6 \text{ V} - 3.4 \text{ V}}{3.4 \text{ V}} \times 100\% = \mathbf{5.88\%}$

## Chapter 3

### Section 3-3 Varactor Diodes

16. At 5 V,  $C = 20$  pF  
At 20 V,  $C = 10$  pF  
 $\Delta C = 20$  pF  $- 10$  pF = **10 pF** (decrease)

17. From the graph,  $V_R = 3$  V @ 25 pF

18. 
$$f_r = \frac{1}{\sqrt{2\pi LC_T}}$$

$$C_T = \frac{1}{4\pi^2 L f_r^2} = \frac{1}{4\pi^2 (2 \text{ mH})(1 \text{ MHz})^2} = 12.7 \text{ pF}$$

Since they are in series, each varactor must have a capacitance of  $2C_T = \mathbf{25.4 \text{ pF}}$

19. Each varactor has a capacitance of 25.4 pF. Therefore, from the graph,  $V_R \cong \mathbf{2.5 \text{ V}}$ .

### Section 3-4 Optical Diodes

20. Assuming  $V_F = 1.2$  V,  
$$I_F = \frac{24 \text{ V} - 1.2 \text{ V}}{680 \Omega} = 33.5 \text{ mA}$$

From the graph, the radiant power is approximately **80 mW**.

21. See Figure 3-3.

$$R = \frac{5 \text{ V} - 0.7 \text{ V}}{30 \text{ mA}} = 143 \Omega$$

Use nearest standard 1% value of 147  $\Omega$  or 5% value of 150  $\Omega$ .

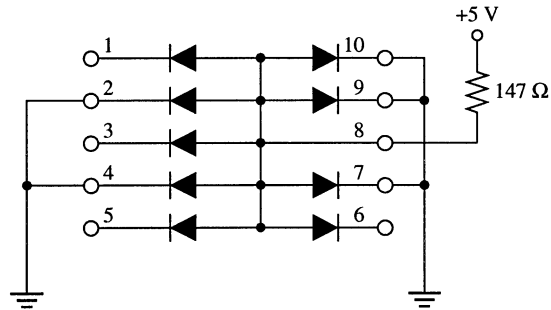

Figure 3-3

22. 
$$I_R = \frac{10 \text{ V}}{200 \text{ k}\Omega} = 50 \mu\text{A}$$

23. (a)  $R = \frac{V_S}{I} = \frac{3 \text{ V}}{100 \mu\text{A}} = 30 \text{ k}\Omega$

(b)  $R = \frac{V_S}{I} = \frac{3 \text{ V}}{350 \mu\text{A}} = 8.57 \text{ k}\Omega$

(c)  $R = \frac{V_S}{I} = \frac{3 \text{ V}}{510 \mu\text{A}} = 5.88 \text{ k}\Omega$

24. The microammeter reading will increase.

### *Section 3-5 Other Types of Diodes*

25.  $R = \frac{\Delta V}{\Delta I} = \frac{125 \text{ mV} - 200 \text{ mV}}{0.25 \text{ mA} - 0.15 \text{ mA}} = \frac{-75 \text{ mV}}{0.10 \text{ mA}} = -750 \Omega$

26. Tunnel diodes are used in oscillators.

27. The reflective ends cause the light to bounce back and forth, thus increasing the intensity of the light. The partially reflective end allows a portion of the reflected light to be emitted.

### *Section 3-6 Troubleshooting*

28. (a) All voltages are correct.  
 (b)  $V_3$  should be 12 V. Zener is open.  
 (c)  $V_1$  should be 110 V. Fuse is open.  
 (d) Capacitor  $C_1$  is open.  
 (e) Transformer winding open.

29. (a) With  $D_5$  open,  $V_{\text{OUT}} \cong 30 \text{ V}$   
 (b) With  $R$  open,  $V_{\text{OUT}} = 0 \text{ V}$   
 (c) With  $C$  leaky,  $V_{\text{OUT}}$  has excessive **120 Hz ripple limited to 12 V**  
 (d) With  $C$  open,  $V_{\text{OUT}}$  is **full wave rectified voltage limited to 12 V**  
 (e) With  $D_3$  open,  $V_{\text{OUT}}$  has **60 Hz ripple limited to 12 V**  
 (f) With  $D_2$  open,  $V_{\text{OUT}}$  has **60 Hz ripple limited to 12 V**  
 (g) With  $T$  open,  $V_{\text{OUT}} = 0 \text{ V}$   
 (h) With  $F$  open,  $V_{\text{OUT}} = 0 \text{ V}$

30. The voltage reading is too low. Inspection of the circuit board reveals that the second diode from the top is connected backwards.

31. The input voltage is correct but there is 0 V at the rectifier output. Possible causes are open fuse, open transformer, or open resistor. Cannot be isolated further with given measurements.

32. The LED ( $D_6$ ) will not light when any of the following faults occur:  $D_6$  open,  $R_1$  open,  $R_2$  open, fuse blown, transformer winding open,  $D_5$  shorted, or  $C_1$  shorted.

## Chapter 3

---

33. The photodiode  $D_1$  will not respond when there is:  
No dc voltage  
 $R_1$  open  
 $D_1$  open  
A short in the threshold, counter, and display circuits.

Step 1: Check for 5.1 V dc.

Step 2: Check for a dc voltage at the  $D_1$  cathode.

### Data Sheet Problems

34. From the data sheet of textbook Figure 3-7:
- (a) @ 25°C:  $P_{D(\max)} = 1.0 \text{ W}$  for a 1N4738
  - (b) For a 1N4751:
    - @ 70°C:  $P_{D(\max)} = 1.0 \text{ W} - (6.67 \text{ mW}/^\circ\text{C})(20^\circ\text{C}) = 1.0 \text{ W} - 133 \text{ mW} = 867 \text{ mW}$
    - @ 100°C:  $P_{D(\max)} = 1.0 \text{ W} - (6.67 \text{ mW}/^\circ\text{C})(50^\circ\text{C}) = 1.0 \text{ W} - 333 \text{ mW} = 667 \text{ mW}$
  - (c)  $I_{ZK} = 0.5 \text{ mA}$  for a 1N4738
  - (d) @ 25°C:  $I_{ZM} = 1 \text{ W}/27 \text{ V} = 37.0 \text{ mA}$  for a 1N4750
  - (e)  $\Delta Z_Z = 700 \Omega - 7.0 \Omega = 693 \Omega$  for a 1N4740
  - (f) @ 25°C:  $V_{Z(\max)} = 6.8 \text{ V} + (4 \text{ mV}/^\circ\text{C})(25^\circ\text{C}) = 6.8 \text{ V} + 100 \text{ mV} = 6.9 \text{ V}$  for a 1N4736
  - (g) @ 75°C:  $V_{Z(\min)} = 20 \text{ V} + (15 \text{ mV}/^\circ\text{C})(50^\circ\text{C}) = 20 \text{ V} + 750 \text{ mV} = 20.8 \text{ V}$  for a 1N4747
35. From the data sheet of textbook Figure 3-22:
- (a)  $V_{R(\max)} = 60 \text{ V}$  for a 1N5139
  - (b) For a 1N5141:
    - @ 60°C:  $P_{D(\max)} = 400 \text{ mW} - (2.67 \text{ mW}/^\circ\text{C})(35^\circ\text{C}) = 400 \text{ mW} - 93.5 \text{ mW} = 307 \text{ mW}$
  - (c) For a 1N5148:
    - @ 80°C:  $P_{D(\max)} = 2.0 \text{ W} - (13.3 \text{ mW}/^\circ\text{C})(55^\circ\text{C}) = 2.0 \text{ W} - 732 \text{ mW} = 1.27 \text{ W}$
  - (d)  $C_D \cong 21 \text{ pF}$  for a 1N5148
  - (e) For maximum figure of merit a 1N5139 is best.
  - (f) For  $V_R = 60 \text{ V}$ ,  $C_D = 13.5 \text{ pF}/2.8 = 4.82 \text{ pF}$  for a 1N5142.
36. From the data sheet of textbook 3-31:
- (a) 9 V cannot be applied in reverse across an MLED81.
  - (b) When 5.1 V is used to forward-bias the MLED81 for  $I_F = 100 \text{ mA}$ ,  $V_F \cong 1.42 \text{ V}$   
$$R = \frac{5.1 \text{ V} - 1.42 \text{ V}}{100 \text{ mA}} = \frac{3.68 \text{ V}}{100 \text{ mA}} = 36.8 \Omega$$
  - (c) At 45°C maximum power dissipation is  
 $100 \text{ mW} - (2.2 \text{ mW}/^\circ\text{C})(20^\circ\text{C}) = 100 \text{ mW} - 44 \text{ mW} = 56 \text{ mW}$   
If  $V_F = 1.5 \text{ V}$  and  $I_F = 50 \text{ mA}$ ,  $P_D = 75 \text{ mW}$ . The power rating is **exceeded**.
  - (d) For  $I_F = 30 \text{ mA}$ , maximum axial radiant intensity is approximately **4.3 mW/sr**.
  - (e) For  $I_F = 20 \text{ mA}$  and  $\theta = 20^\circ$ , radiant intensity is 90% or maximum or  $(0.9)(20 \text{ mW/sr}) = 18 \text{ mW/sr}$
37. From the data sheet of textbook Figure 3-36:
- (a) With no incident light and a 10 k $\Omega$  series resistor, the voltage across MRD821 is approximately equal to the **reverse bias source voltage**.
  - (b) Reverse current is greatest at about **940 nm**.
  - (c) At  $T_A \cong 60^\circ\text{C}$ , dark current is about **40 nA**.



- (d) Sensitivity is maximum for  $\lambda = 940 \text{ nm}$ .
- (e) At 900 nm the sensitivity is about 80% of maximum  $(0.8)(50 \mu\text{A/mW/cm}^2) = 40 \mu\text{A/mW/cm}^2$
- (f) For  $\lambda = 900 \text{ nm}$ ,  $\theta = 40^\circ$  and an irradiance of  $3 \text{ mW/cm}^2$   
 $I_D = (0.8)(0.87)(50 \mu\text{A/mW/cm}^2)(3 \text{ mW/cm}^2) = 104 \mu\text{A}$

### Advanced Problems

38. See Figure 3-4.

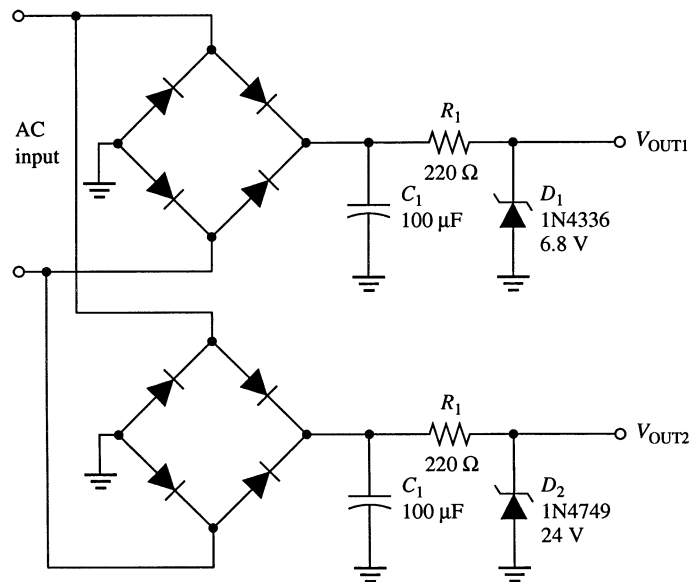

**Figure 3-4**

39.  $V_{OUT(1)} \cong 6.8 \text{ V}$ ,  $V_{OUT(2)} \cong 24 \text{ V}$

40. For a  $1.0 \text{ k}\Omega$  load on each output:

$$I_{OUT(1)} \cong \frac{6.8 \text{ V}}{1.0 \text{ k}\Omega} = 6.8 \text{ mA}$$

$$I_{OUT(2)} \cong \frac{24 \text{ V}}{1.0 \text{ k}\Omega} = 24 \text{ mA}$$

$$I_{Z1} \cong 37 \text{ mA for } V_{ZT}$$

$$I_{Z2} \cong 10.5 \text{ mA for } V_{ZT}$$

$$I_T = 6.8 \text{ mA} + 24 \text{ mA} + 37 \text{ mA} + 10.5 \text{ mA} = 78.3 \text{ mA}$$

The fuse rating should be  $100 \text{ mA}$  or  $1/8 \text{ A}$ .

41. See Figure 3-5.

Use a 1N4738 zener.

$$I_T = 35 \text{ mA} + 31 \text{ mA} = 66 \text{ mA}$$

$$R = \frac{24 \text{ V} - 8.2 \text{ V}}{66 \text{ mA}} = 239 \Omega$$

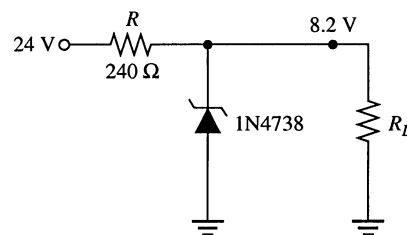

**Figure 3-5**

## Chapter 3

42. Use a 1N5148 varactor diode.  
 From the graph in textbook Figure 3-22, the maximum and minimum varactor capacitances are roughly  $C_{\max} \cong 80 \text{ pF @ } 1 \text{ V}$  and  $C_{\min} \cong 12 \text{ pF @ } 60 \text{ V}$   
 Use these capacitance values to calculate an inductance range for 350 kHz and 850 kHz:

$$L_{\max} = \left( \frac{1}{2\pi f_{\min} \sqrt{C_{\min}}} \right)^2 = 2.92 \text{ mH}$$

$$L_{\min} = \left( \frac{1}{2\pi f_{\max} \sqrt{C_{\max}}} \right)^2 = 2.58 \text{ mH}$$

Choose  $L = 2.7 \text{ mH}$  and calculate required  $C_{\min}$  and  $C_{\max}$ :

$$C_{\min} = \left( \frac{1}{2\pi f_{\max} \sqrt{L}} \right)^2 = 13 \text{ pF}$$

$$C_{\max} = \left( \frac{1}{2\pi f_{\min} \sqrt{L}} \right)^2 = 77 \text{ pF}$$

From the graph in Figure 3-22, the reverse voltages for these capacitance values are approximately:

$$V_{R(\max)} \cong 50 \text{ V for } 13 \text{ pF}$$

$$V_{R(\min)} \cong 1.2 \text{ V for } 77 \text{ pF}$$

Let  $V_{\text{BIAS}} = 100 \text{ V}$ .

$$V_{R(\min)} = \left( \frac{R_3}{R_2 + R_3 + R_4 + R_5} \right) V_{\text{BIAS}}$$

$$V_{R(\max)} = \left( \frac{R_3 + R_4}{R_2 + R_3 + R_4 + R_5} \right) V_{\text{BIAS}}$$

Let  $R_2 + R_3 + R_4 + R_5 = 100 \text{ k}\Omega$ .

$$R_3 = \frac{V_{R(\min)}(R_2 + R_3 + R_4 + R_5)}{V_{\text{BIAS}}} = \frac{1.2 \text{ V}(100 \text{ k}\Omega)}{100 \text{ V}} = 1.2 \text{ k}\Omega$$

$$R_4 = \frac{V_{R(\max)}(R_2 + R_3 + R_4 + R_5)}{V_{\text{BIAS}}} - R_3 = \frac{50 \text{ V}(100 \text{ k}\Omega)}{100 \text{ V}} - 1.2 \text{ k}\Omega = 49 \text{ k}\Omega$$

Use  $R_4 = 50 \text{ k}\Omega$ .

$$R_2 + R_5 = 100 \text{ k}\Omega - 50.2 \text{ k}\Omega = 49.8 \text{ k}\Omega$$

Let  $R_5 = 1.2 \text{ k}\Omega$ .

$$R_2 = 49.8 \text{ k}\Omega - 1.2 \text{ k}\Omega = 48.6 \text{ k}\Omega$$

Use  $R_2 = 47 \text{ k}\Omega$ .

All other component values are the same as in textbook Figure 3-24.

43. See Figure 3-6.

$$R = \frac{V_D}{I} = \frac{12\text{ V} - 0.7\text{ V}}{20\text{ mA}} = 565\ \Omega$$

Use standard value of 560  $\Omega$ .

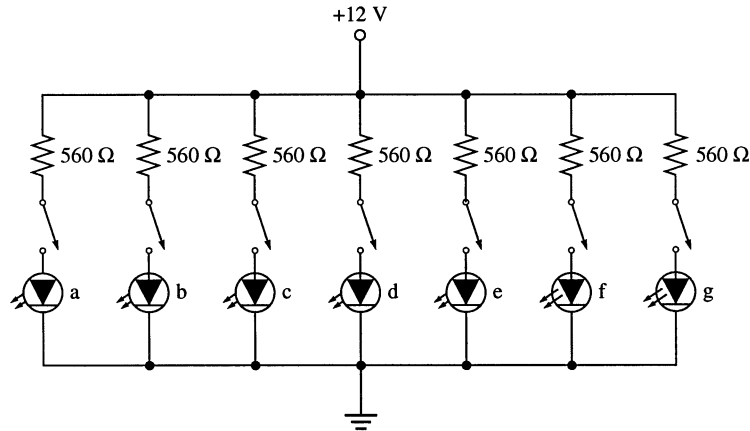

**Figure 3-6**

44. See Figure 3-7.

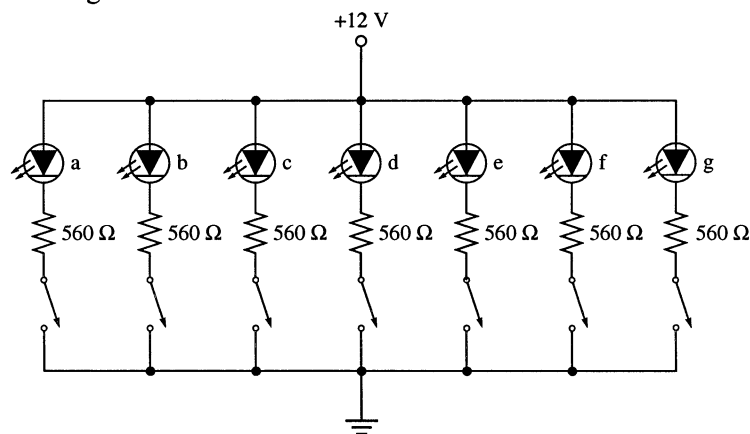

**Figure 3-7**

## EWB/Multisim Troubleshooting Problems

The solutions showing instrument connections for Problems 45 through 48 are available in the Solutions folder for Chapter 3 on the CD-ROM provided with the textbook. The solutions may be accessed using the password *ED5FLOYD*. The faults in the circuit files may be accessed using the password *book* (all lowercase).

- 45. Zener diode open
- 46. Capacitor open
- 47. Zener diode shorted
- 48. Resistor open

# Chapter 4

## Bipolar Junction Transistors (BJTs)

---

### *Section 4-1 Transistor Structure*

1. Majority carriers in the base region of an *npn* transistor are **holes**.
2. Because of the narrow base region, the minority carriers invading the base region find a limited number of partners for recombination and, therefore, move across the junction into the collector region rather than out of the base lead.

### *Section 4-2 Basic Transistor Operation*

3. The base is narrow and lightly doped so that a small recombination (base) current is generated compared to the collector current.
4.  $I_B = 0.02I_E = 0.02(30 \text{ mA}) = 0.6 \text{ mA}$   
 $I_C = I_E - I_B = 30 \text{ mA} - 0.6 \text{ mA} = \mathbf{29.4 \text{ mA}}$
5. The base must be negative with respect to the collector and positive with respect to the emitter.
6.  $I_C = I_E - I_B = 5.34 \text{ mA} - 475 \mu\text{A} = \mathbf{4.87 \text{ mA}}$

### *Section 4-3 Transistor Characteristics and Parameters*

7.  $\alpha_{DC} = \frac{I_C}{I_E} = \frac{8.23 \text{ mA}}{8.69 \text{ mA}} = \mathbf{0.947}$
8.  $\beta_{DC} = \frac{I_C}{I_B} = \frac{25 \text{ mA}}{200 \mu\text{A}} = \mathbf{125}$
9.  $I_B = I_E - I_C = 20.5 \text{ mA} - 20.3 \text{ mA} = 0.2 \text{ mA} = 200 \mu\text{A}$   
 $\beta_{DC} = \frac{I_C}{I_B} = \frac{20.5 \text{ mA}}{200 \mu\text{A}} = \mathbf{102.5}$
10.  $I_E = I_C + I_B = 5.35 \text{ mA} + 50 \mu\text{A} = 5.40 \text{ mA}$   
 $\alpha_{DC} = \frac{I_C}{I_E} = \frac{5.35 \text{ mA}}{5.40 \text{ mA}} = \mathbf{0.99}$
11.  $I_C = \alpha_{DC}I_E = 0.96(9.35 \text{ mA}) = \mathbf{8.98 \text{ mA}}$

$$12. \quad I_C = \frac{V_{R_C}}{R_C} = \frac{5 \text{ V}}{1.0 \text{ k}\Omega} = 5 \text{ mA}$$

$$\beta_{DC} = \frac{I_C}{I_B} = \frac{5 \text{ mA}}{50 \text{ }\mu\text{A}} = 100$$

$$13. \quad \alpha_{DC} = \frac{\beta_{DC}}{\beta_{DC} + 1} = \frac{100}{101} = 0.99$$

$$14. \quad I_B = \frac{V_{BB} - V_{BE}}{R_B} = \frac{4 \text{ V} - 0.7 \text{ V}}{4.7 \text{ k}\Omega} = \frac{3.3 \text{ V}}{4.7 \text{ k}\Omega} = 702 \text{ }\mu\text{A}$$

$$I_C = \frac{V_{CC} - V_{CE}}{R_C} = \frac{24 \text{ V} - 8 \text{ V}}{470 \text{ }\Omega} = 34 \text{ mA}$$

$$I_E = I_C + I_B = 34 \text{ mA} + 702 \text{ }\mu\text{A} = 34.7 \text{ mA}$$

$$\beta_{DC} = \frac{I_C}{I_B} = \frac{34 \text{ mA}}{702 \text{ }\mu\text{A}} = 48.4$$

$$15. \quad (a) \quad V_{BE} = 0.7 \text{ V}$$

$$I_B = \frac{V_{BB} - V_{BE}}{R_B} = \frac{4.3 \text{ V}}{3.9 \text{ k}\Omega} = 1.1 \text{ mA}$$

$$I_C = \beta_{DC} I_B = 50(1.1 \text{ mA}) = 55 \text{ mA}$$

$$V_{CE} = V_{CC} - I_C R_C = 15 \text{ V} - (55 \text{ mA})(180 \text{ }\Omega) = 5.10 \text{ V}$$

$$V_{BC} = V_{BE} - V_{CE} = 0.7 \text{ V} - 5.10 \text{ V} = -4.40 \text{ V}$$

$$(b) \quad V_{BE} = -0.7 \text{ V}$$

$$I_B = \frac{V_{BB} - V_{BE}}{R_B} = \frac{-3 \text{ V} - (-0.7 \text{ V})}{27 \text{ k}\Omega} = \frac{-2.3 \text{ V}}{27 \text{ k}\Omega} = -85.2 \text{ }\mu\text{A}$$

$$I_C = \beta_{DC} I_B = 125(-85.2 \text{ }\mu\text{A}) = -10.7 \text{ mA}$$

$$V_{CE} = V_{CC} - I_C R_C = -8 \text{ V} - (-10.7 \text{ mA})(390 \text{ }\Omega) = -3.83 \text{ V}$$

$$V_{BC} = V_{BE} - V_{CE} = 0.7 \text{ V} - (-3.83 \text{ V}) = 3.13 \text{ V}$$

$$16. \quad (a) \quad I_{C(\text{sat})} = \frac{V_{CC}}{R_C} = \frac{15 \text{ V}}{180 \text{ }\Omega} = 83.3 \text{ mA}$$

$$I_B = \frac{V_{BB} - V_{BE}}{R_B} = \frac{5 \text{ V} - 0.7 \text{ V}}{3.9 \text{ k}\Omega} = 1.1 \text{ mA}$$

$$I_C = \beta_{DC} I_B = 50(1.1 \text{ mA}) = 55 \text{ mA}$$

$$I_C < I_{C(\text{sat})}$$

Therefore, the transistor is **not saturated**.

## Chapter 4

---

$$(b) I_{C(\text{sat})} = \frac{V_{CC}}{R_C} = \frac{8 \text{ V}}{390 \Omega} = 20.5 \text{ mA}$$

$$I_B = \frac{V_{BB} - V_{BE}}{R_B} = \frac{3 \text{ V} - 0.7 \text{ V}}{27 \text{ k}\Omega} = 85.2 \mu\text{A}$$

$$I_C = \beta_{DC} I_B = 125(85.2 \mu\text{A}) = 10.7 \text{ mA}$$

$$I_C < I_{C(\text{sat})}$$

Therefore, the transistor is **not saturated**.

17.  $V_B = 2 \text{ V}$

$$V_E = V_B - V_{BE} = 2 \text{ V} - 0.7 \text{ V} = 1.3 \text{ V}$$

$$I_E = \frac{V_E}{R_E} = \frac{1.3 \text{ V}}{1.0 \text{ k}\Omega} = 1.3 \text{ mA}$$

$$I_C = \alpha_{DC} I_E = (0.98)(1.3 \text{ mA}) = 1.27 \text{ mA}$$

$$\beta_{DC} = \frac{\alpha_{DC}}{1 - \alpha_{DC}} = \frac{0.98}{1 - 0.98} = 49$$

$$I_B = I_E - I_C = 1.3 \text{ mA} - 1.27 \text{ mA} = 30 \mu\text{A}$$

18. (a)  $V_B = V_{BB} = 10 \text{ V}$

$$V_C = V_{CC} = 20 \text{ V}$$

$$V_E = V_B - V_{BE} = 10 \text{ V} - 0.7 \text{ V} = 9.3 \text{ V}$$

$$V_{CE} = V_C - V_E = 20 \text{ V} - 9.3 \text{ V} = 10.7 \text{ V}$$

$$V_{BE} = 0.7 \text{ V}$$

$$V_{BC} = V_B - V_C = 10 \text{ V} - 20 \text{ V} = -10 \text{ V}$$

(b)  $V_B = V_{BB} = -4 \text{ V}$

$$V_C = V_{CC} = -12 \text{ V}$$

$$V_E = V_B - V_{BE} = -4 \text{ V} - (-0.7 \text{ V}) = -3.3 \text{ V}$$

$$V_{CE} = V_C - V_E = -12 \text{ V} - (-3.3 \text{ V}) = -8.7 \text{ V}$$

$$V_{BE} = -0.7 \text{ V}$$

$$V_{BC} = V_B - V_C = -4 \text{ V} - (-12 \text{ V}) = 8 \text{ V}$$

19. For  $\beta_{DC} = 100$ :

$$I_E = \frac{V_B - V_{BE}}{R_E} = \frac{10 \text{ V} - 0.7 \text{ V}}{10 \text{ k}\Omega} = 930 \mu\text{A}$$

$$\alpha_{DC} = \frac{\beta_{DC}}{1 + \beta_{DC}} = \frac{100}{101} = 0.990$$

$$I_C = \alpha_{DC} I_E = (0.990)(930 \mu\text{A}) = 921 \mu\text{A}$$

For  $\beta_{DC} = 150$ :

$$I_E = 930 \mu\text{A}$$

$$\alpha_{DC} = \frac{\beta_{DC}}{1 + \beta_{DC}} = \frac{150}{151} = 0.993$$

$$I_C = \alpha_{DC} I_E = (0.993)(930 \mu\text{A}) = 924 \mu\text{A}$$

$$\Delta I_C = 924 \mu\text{A} - 0.921 \mu\text{A} = 3 \mu\text{A}$$

20.  $P_{D(\max)} = V_{CE}I_C$   
 $V_{CE(\max)} = \frac{P_{D(\max)}}{I_C} = \frac{1.2 \text{ W}}{50 \text{ mA}} = 24 \text{ V}$

21.  $P_{D(\max)} = 0.5 \text{ W} - (75^\circ\text{C})(1 \text{ mW}/^\circ\text{C}) = 0.5 \text{ W} - 75 \text{ mW} = 425 \text{ mW}$

**Section 4-4 The Transistor as an Amplifier**

22.  $V_{out} = A_v V_{in} = 50(100 \text{ mV}) = 5 \text{ V}$

23.  $A_v = \frac{V_{out}}{V_{in}} = \frac{10 \text{ V}}{300 \text{ mV}} = 33.3$

24.  $A_v = \frac{R_C}{r'_e} = \frac{560 \Omega}{10 \Omega} = 56$   
 $V_c = V_{out} = A_v V_{in} = 56(50 \text{ mV}) = 2.8 \text{ V}$

**Section 4-5 The Transistor as a Switch**

25.  $I_{C(\text{sat})} = \frac{V_{CC}}{R_C} = \frac{5 \text{ V}}{10 \text{ k}\Omega} = 500 \mu\text{A}$

$I_{B(\text{min})} = \frac{I_{C(\text{sat})}}{\beta_{DC}} = \frac{500 \mu\text{A}}{150} = 3.33 \mu\text{A}$

$I_{B(\text{min})} = \frac{V_{IN(\text{min})} - 0.7 \text{ V}}{R_B}$

$R_B I_{B(\text{min})} = V_{IN(\text{min})} - 0.7 \text{ V}$

$V_{IN(\text{min})} = R_B I_{B(\text{min})} + 0.7 \text{ V} = (3.33 \mu\text{A})(1.0 \text{ M}\Omega) + 0.7 \text{ V} = 4.03 \text{ V}$

26.  $I_{C(\text{sat})} = \frac{15 \text{ V}}{1.2 \text{ k}\Omega} = 12.5 \text{ mA}$

$I_{B(\text{min})} = \frac{I_{C(\text{sat})}}{\beta_{DC}} = \frac{12.5 \text{ mA}}{50} = 250 \mu\text{A}$

$R_{B(\text{min})} = \frac{V_{IN} - 0.7 \text{ V}}{I_{B(\text{min})}} = \frac{4.3 \text{ V}}{250 \mu\text{A}} = 17.2 \text{ k}\Omega$

$V_{IN(\text{cutoff})} = 0 \text{ V}$

**Section 4-6 Transistor Packages and Terminal Identification**

27. See Figure 4-1.

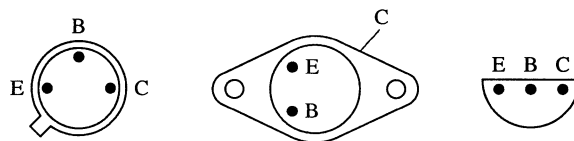

Figure 4-1

## Chapter 4

---

28. (a) Small-signal  
(b) Power  
(c) Power  
(d) Small-signal  
(e) RF

### Section 4-7 Troubleshooting

29. With the positive probe on the emitter and the negative probe on the base, the ohmmeter indicates an **open**, since this reverse-biases the base-emitter junction. With the positive probe on the base and the negative probe on the emitter, the ohmmeter indicates a **very low resistance**, since this forward-biases the base-collector junction.
30. (a) Transistor's collector junction or terminal is open.  
(b) Collector resistor is open.  
(c) Operating properly.  
(d) Transistor's base junction or terminal open (no base or collector current).

31. (a) 
$$I_B = \frac{5\text{ V} - 0.7\text{ V}}{68\text{ k}\Omega} = 63.2\ \mu\text{A}$$
$$I_C = \frac{9\text{ V} - 3.2\text{ V}}{3.3\text{ k}\Omega} = 1.76\text{ mA}$$
$$\beta_{DC} = \frac{I_C}{I_B} = \frac{1.76\text{ mA}}{63.2\ \mu\text{A}} = 27.8$$

(b) 
$$I_B = \frac{4.5\text{ V} - 0.7\text{ V}}{27\text{ k}\Omega} = 141\ \mu\text{A}$$
$$I_C = \frac{24\text{ V} - 16.8\text{ V}}{470\ \Omega} = 15.3\text{ mA}$$
$$\beta_{DC} = \frac{I_C}{I_B} = \frac{15.3\text{ mA}}{141\ \mu\text{A}} = 109$$

### System Application Problems

32. With the remote switches closed,  $Q_1$  should be on and  $Q_2$  should be off, keeping the relay contacts (pins 10 and 11) open. When a remote switch opens,  $Q_1$  should turn off and  $Q_2$  should turn on, energizing the relay and closing the contacts. If the  $Q_1$  collector or base is open, such that  $Q_1$  is off all the time,  $Q_2$  will stay on all the time, so this is not the problem. Most likely,  $Q$  has failed so that it remains off all the time or  $R_3$ , or  $R_4$ , could be open. Also, the relay could be faulty.
33. With the remote switches closed,  $Q_1$  and  $Q_3$  should be on and  $Q_2$  and  $Q_4$  should be off keeping the relay contacts (pins 10 and 11) open. When a remote switch opens,  $Q_1$  (or  $Q_3$ ) should turn off and  $Q_2$  (or  $Q_4$ ) should turn on, thus energizing the relay and closing the contacts (pins 10 and 11). If the  $Q_1$  (or  $Q_3$ ) collector or base is open, such that  $Q_1$  (or  $Q_3$ ) is off all the time,  $Q_2$  (or  $Q_4$ ) will stay on all the time. Most likely, either  $Q_2$  (or  $Q_4$ ) or its associated circuitry is faulty such that it remains on all the time. An internally open junction



in  $Q_1$  or  $Q_3$  or an open resistor ( $R_1$  or  $R_6$ ) could cause this problem. Also, the relay may be faulty.

34. The constant 0.1 V at pin 9 indicates that  $Q_6$  is saturated. Most likely  $Q_5$  has failed such that it always acts as an open switch keeping  $Q_6$  saturated. First look for obvious problems such as a burned resistor ( $R_{11}$ ) or a bad contact. Next check the  $Q_5$  collector with pin 7 connected to pin 6. You should see approximately 0.1 V at the  $Q_5$  collector. If  $Q_5$  is open, you will see approximately 3.6 V at the collector.

### ***Data Sheet Problems***

35. From the data sheet of textbook Figure 4-19:
- (a) For a 2N3903,  $V_{CEO(max)} = 40 \text{ V}$
  - (b) For a 2N3904,  $I_{C(max)} = 200 \text{ mA}$
  - (c) For a 2N3903 @  $25^\circ\text{C}$ ,  $P_{D(max)} = 625 \text{ mW}$
  - (d) For a 2N3904 @  $T_C = 25^\circ\text{C}$ ,  $P_{D(max)} = 1.5 \text{ W}$
  - (e) For a 2N3903 with  $I_C = 1 \text{ mA}$ ,  $h_{FE(min)} = 35$
36. For a 2N3904 with  $T_A = 65^\circ\text{C}$ :
- $$P_{D(max)} = 625 \text{ mW} - (65^\circ\text{C} - 25^\circ\text{C})(5.0 \text{ mW}/^\circ\text{C})$$
- $$= 625 \text{ mW} - 40^\circ\text{C}(5.0 \text{ mW}/^\circ\text{C}) = 625 \text{ mW} - 200 \text{ mW} = 425 \text{ mW}$$
37. For a 2N3903 with  $T_C = 45^\circ\text{C}$ :
- $$P_{D(max)} = 1.5 \text{ W} - (45^\circ\text{C} - 25^\circ\text{C})(12 \text{ mW}/^\circ\text{C})$$
- $$= 1.5 \text{ W} - 20^\circ\text{C}(12 \text{ mW}/^\circ\text{C}) = 1.5 \text{ W} - 240 \text{ mW} = 1.26 \text{ W}$$
38. For the circuits of textbook Figure 4-56:
- (a)  $I_B = \frac{3 \text{ V} - 0.7 \text{ V}}{330 \Omega} = \frac{2.3 \text{ V}}{330 \Omega} = 6.97 \text{ mA}$   
 $h_{FE} = 15$   
 $I_C = 15(6.97 \text{ mA}) = 105 \text{ mA}$   
 $V_C = 30 \text{ V} - (105 \text{ mA})(270 \Omega) = 30 \text{ V} - 28.2 \text{ V} = 1.8 \text{ V}$   
 $V_{CE} = 1.8 \text{ V} - 0.7 \text{ V} = 1.1 \text{ V}$   
 $P_D = (1.1 \text{ V})(105 \text{ mA}) = 112 \text{ mW}$   
 At  $50^\circ\text{C}$ ,  $P_{D(max)} = 625 \text{ mW} - (50^\circ\text{C} - 25^\circ\text{C})(5.0 \text{ mW}/^\circ\text{C}) = 500 \text{ mW}$   
**No parameter is exceeded.**
  - (b)  $V_{CEO} = 45 \text{ V}$  which **exceeds**  $V_{CEO(max)}$ .
39. For the circuits of textbook Figure 4-57:
- (a)  $I_B = \frac{5 \text{ V} - 0.7 \text{ V}}{10 \text{ k}\Omega} = \frac{4.3 \text{ V}}{10 \text{ k}\Omega} = 4.30 \mu\text{A}$   
 $h_{FE(max)} = 150$   
 $I_C = 150(4.30 \mu\text{A}) = 64.5 \text{ mA}$   
 $I_{C(sat)} = \frac{9 \text{ V}}{1.0 \text{ k}\Omega} = 9 \text{ mA}$   
**The transistor is saturated.**

## Chapter 4

---

$$(b) I_B = \frac{3 \text{ V} - 0.7 \text{ V}}{100 \text{ k}\Omega} = \frac{2.3 \text{ V}}{100 \text{ k}\Omega} = 23 \mu\text{A}$$

$$h_{FE(\max)} = 300$$

$$I_C = 300(23 \mu\text{A}) = 6.90 \text{ mA}$$

$$I_{C(\text{sat})} = \frac{12 \text{ V}}{560 \Omega} = 21.4 \text{ mA}$$

**The transistor is not saturated.**

$$40. \quad I_{B(\min)} = \frac{I_C}{h_{FE(\max)}} = \frac{10 \text{ mA}}{150} = 66.7 \mu\text{A}$$

$$I_{B(\max)} = \frac{I_C}{h_{FE(\min)}} = \frac{10 \text{ mA}}{50} = 200 \mu\text{A}$$

41. For the circuits of textbook Figure 4-58:

$$(a) I_B = \frac{8 \text{ V} - 0.7 \text{ V}}{68 \text{ k}\Omega} = \frac{7.3 \text{ V}}{68 \text{ k}\Omega} = 107 \mu\text{A}$$

$$h_{FE} = 150$$

$$I_C = 150(107 \mu\text{A}) = 16.1 \text{ mA}$$

$$V_C = 15 \text{ V} - (16.1 \text{ mA})(680 \Omega) = 15 \text{ V} - 10.95 \text{ V} = 4.05 \text{ V}$$

$$V_{CE} = 4.05 \text{ V} - 0.7 \text{ V} = 3.35 \text{ V}$$

$$P_D = (3.35 \text{ V})(16.1 \text{ mA}) = 53.9 \text{ mW}$$

$$\text{At } 40^\circ\text{C}, P_{D(\max)} = 360 \text{ mW} - (40^\circ\text{C} - 25^\circ\text{C})(2.06 \text{ mW}/^\circ\text{C}) = 329 \text{ mW}$$

**No parameter is exceeded.**

$$(b) I_B = \frac{5 \text{ V} - 0.7 \text{ V}}{4.7 \text{ k}\Omega} = \frac{4.3 \text{ V}}{4.7 \text{ k}\Omega} = 915 \mu\text{A}$$

$$h_{FE} = 300$$

$$I_C = 300(915 \mu\text{A}) = 274 \text{ mA}$$

$$I_{C(\text{sat})} \cong \frac{35 \text{ V} - 0.3 \text{ V}}{470 \Omega} = 73.8 \text{ mA}$$

The transistor is in hard saturation. Assuming  $V_{CE(\text{sat})} = 0.3 \text{ V}$ ,

$$P_D = (0.3 \text{ V})(73.8 \text{ mA}) = 22.1 \text{ mW}$$

**No parameter is exceeded.**

### *Advanced Problems*

$$42. \quad \beta_{DC} = \frac{\alpha_{DC}}{1 - \alpha_{DC}}$$

$$\beta_{DC} - \beta_{DC}\alpha_{DC} = \alpha_{DC}$$

$$\beta_{DC} = \alpha_{DC}(1 + \beta_{DC})$$

$$\alpha_{DC} = \frac{\beta_{DC}}{(1 + \beta_{DC})}$$

43.  $I_C = 150(500 \mu\text{A}) = 75 \text{ mA}$   
 $V_{CE} = 15 \text{ V} - (180 \Omega)(75 \text{ mA}) - 0.7 \text{ V} = 0.8 \text{ V}$   
 Since  $V_{CE(\text{sat})} = 0.3 \text{ V} @ I_C = 50 \text{ mA}$ , the transistor comes out of saturation, although marginally.

44. From the data sheet,  $\beta_{DC(\text{min})} = 15$  (for  $I_C = 100 \text{ mA}$ )

$$I_{B(\text{max})} = \frac{150 \text{ mA}}{15} = 10 \text{ mA}$$

$$R_{B(\text{min})} = \frac{3 \text{ V} - 0.7 \text{ V}}{10 \text{ mA}} = \frac{2.3 \text{ V}}{10 \text{ mA}} = 230 \Omega$$

Use the standard value of  $240 \Omega$  for  $R_B$ .

To avoid saturation, the load resistance cannot exceed about

$$\frac{9 \text{ V} - 1 \text{ V}}{150 \text{ mA}} = 53.3 \Omega$$

See Figure 4-2.

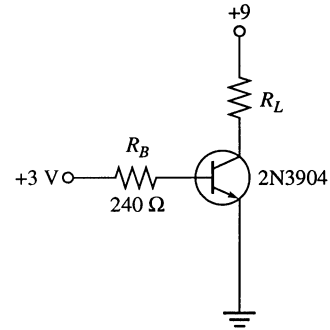

**Figure 4-2**

45. Since  $I_B = 10 \text{ mA}$  for  $I_C = 150 \text{ mA}$ ,

$$R_{B(\text{min})} = \frac{9 \text{ V} - 0.7 \text{ V}}{10 \text{ mA}} = \frac{8.3 \text{ V}}{10 \text{ mA}} = 830 \Omega$$

Use  $910 \Omega$ . The load cannot exceed  $53.3 \Omega$ .

See Figure 4-3.

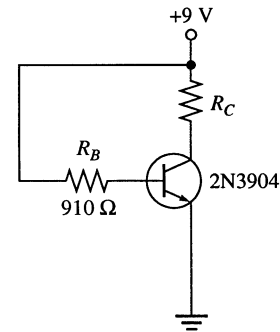

**Figure 4-3**

46.  $R_{C(\text{min})} = A_v r'_e = 50(8 \Omega) = 400 \Omega$  (Use  $430 \Omega$ )

$$I_C = \frac{12 \text{ V} - 5 \text{ V}}{430 \Omega} = 16.3 \text{ mA}$$

Assuming  $h_{FE} = 100$ ,

$$I_B = \frac{16.3 \text{ mA}}{100} = 163 \mu\text{A}$$

$$R_{B(\text{max})} = \frac{4 \text{ V} - 0.7 \text{ V}}{163 \mu\text{A}} = 20.3 \text{ k}\Omega \text{ (Use } 18 \text{ k}\Omega)$$

See Figure 4-4.

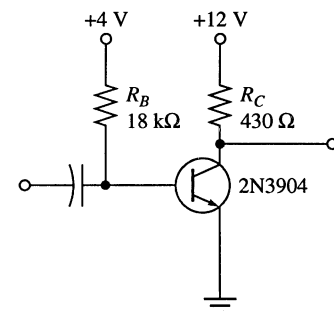

**Figure 4-4**

## Chapter 4

---

### **EWB/Multisim Troubleshooting Problems**

The solutions showing instrument connections for Problems 47 through 54 are available in the Solutions folder for Chapter 4 on the CD-ROM provided with the textbook. The solutions may be accessed using the password *ED5FLOYD*. The faults in the circuit files may be accessed using the password *book* (all lowercase).

- 47.  $R_B$  shorted
- 48.  $R_C$  open
- 49. Collector-emitter shorted
- 50. Collector-emitter open
- 51.  $R_E$  leaky
- 52. Collector-emitter shorted
- 53.  $R_B$  open
- 54.  $R_C$  open

# Chapter 5

## Transistor Bias Circuits

---

### Section 5-1 The DC Operating Point

1. The transistor is biased too close to **saturation**.

2.  $I_C = \beta_{DC} I_B = 75(150 \mu\text{A}) = 11.3 \text{ mA}$   
 $V_{CE} = V_{CC} - I_C R_C = 18 \text{ V} - (11.3 \text{ mA})(1.0 \text{ k}\Omega) = 18 \text{ V} - 11.3 \text{ V} = 6.75 \text{ V}$   
**Q-point:  $V_{CEQ} = 6.75 \text{ V}$ ,  $I_{CQ} = 11.3 \text{ mA}$**

3.  $I_{C(\text{sat})} \cong \frac{V_{CC}}{R_C} = \frac{18 \text{ V}}{1.0 \text{ k}\Omega} = \mathbf{18 \text{ mA}}$

4.  $V_{CE(\text{cutoff})} = \mathbf{18 \text{ V}}$

5. Horizontal intercept (cutoff):  
 $V_{CE} = V_{CC} = \mathbf{20 \text{ V}}$   
 Vertical intercept (saturation):  
 $I_{C(\text{sat})} = \frac{V_{CC}}{R_C} = \frac{20 \text{ V}}{10 \text{ k}\Omega} = \mathbf{2 \text{ mA}}$

6.  $I_B = \frac{V_{BB} - 0.7 \text{ V}}{R_B}$   
 $V_{BB} = I_B R_B + 0.7 \text{ V} = (20 \mu\text{A})(1.0 \text{ M}\Omega) + 0.7 \text{ V} = \mathbf{20.7 \text{ V}}$   
 $I_C = \beta_{DC} I_B = 50(20 \mu\text{A}) = \mathbf{1 \text{ mA}}$   
 $V_{CE} = V_{CC} - I_C R_C = 20 \text{ V} - (1 \text{ mA})(10 \text{ k}\Omega) = \mathbf{10 \text{ V}}$

7. See Figure 5-1.  
 $V_{CE} = V_{CC} - I_C R_C$   
 $R_C = \frac{V_{CC} - V_{CE}}{I_C} = \frac{10 \text{ V} - 4 \text{ V}}{5 \text{ mA}} = \mathbf{1.2 \text{ k}\Omega}$   
 $I_B = \frac{I_C}{\beta_{DC}} = \frac{5 \text{ mA}}{100} = 0.05 \text{ mA}$   
 $R_B = \frac{10 \text{ V} - 0.7 \text{ V}}{0.05 \text{ mA}} = \mathbf{186 \text{ k}\Omega}$   
 $P_{D(\text{min})} = V_{CE} I_C = (4 \text{ V})(5 \text{ mA}) = \mathbf{20 \text{ mW}}$

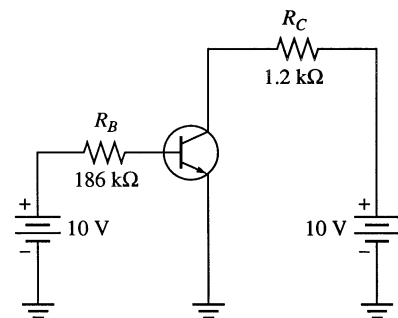

Figure 5-1

## Chapter 5

8. 
$$I_B = \frac{V_{BB} - V_{BE}}{R_B} = \frac{1.5 \text{ V} - 0.7 \text{ V}}{10 \text{ k}\Omega} = 80 \mu\text{A}$$
$$I_{C(\text{sat})} = \frac{V_{CC}}{R_C} = \frac{8 \text{ V}}{390 \Omega} = 20.5 \text{ mA}$$
$$I_C = \beta_{DC} I_B = 75(80 \mu\text{A}) = 6 \text{ mA}$$

The transistor is biased in the linear region because  $0 < I_C < I_{C(\text{sat})}$ .

### Section 5-2 Voltage-Divider Bias

9. 
$$\beta_{DC(\text{min})} R_E = 10 R_2$$
$$\beta_{DC(\text{min})} = \frac{10 R_2}{R_E} = \frac{47 \text{ k}\Omega}{680 \Omega} = 69.1$$
10. 
$$I_{C(\text{sat})} = \frac{V_{CC}}{R_C + R_E} = \frac{15 \text{ V}}{2.18 \text{ k}\Omega} = 6.88 \text{ mA}$$
$$V_{E(\text{sat})} = I_{C(\text{sat})} R_E = (6.88 \text{ mA})(680 \Omega) = 4.68 \text{ V}$$
$$V_B = V_{E(\text{sat})} + 0.7 \text{ V} = 4.68 \text{ V} + 0.7 \text{ V} = 5.38 \text{ V}$$
$$\left( \frac{R_2 \parallel \beta_{DC} R_E}{R_1 + R_2 \parallel \beta_{DC} R_E} \right) 15 \text{ V} = 5.38 \text{ V}$$
$$(R_2 \parallel \beta_{DC} R_E)(15 \text{ V}) = (5.38 \text{ V})(R_1 + R_2 \parallel \beta_{DC} R_E)$$
$$(R_2 \parallel \beta_{DC} R_E)(15 \text{ V}) - (R_2 \parallel \beta_{DC} R_E)(5.38 \text{ V}) = R_1(5.38 \text{ V})$$
$$(R_2 \parallel \beta_{DC} R_E)(15 \text{ V} - 5.38 \text{ V}) = (22 \text{ k}\Omega)(5.38 \text{ V})$$
$$R_2 \parallel \beta_{DC} R_E = \frac{(22 \text{ k}\Omega)(5.38 \text{ V})}{15 \text{ V} - 5.38 \text{ V}} = 12.3 \text{ k}\Omega$$
$$\frac{1}{R_2} + \frac{1}{\beta_{DC} R_E} = \frac{1}{12.3 \text{ k}\Omega}$$
$$\frac{1}{R_2} + \frac{1}{102 \text{ k}\Omega} = \frac{1}{12.3 \text{ k}\Omega}$$
$$\frac{1}{R_2} = 71.5 \mu\text{S}$$
$$R_2 = 14 \text{ k}\Omega$$
11. 
$$V_B = \left( \frac{R_2}{R_1 + R_2} \right) V_{CC} = \left( \frac{2 \text{ k}\Omega}{24 \text{ k}\Omega} \right) 15 \text{ V} = 1.25 \text{ V}$$
$$V_E = 1.25 \text{ V} - 0.7 \text{ V} = 0.55 \text{ V}$$
$$I_E = \frac{V_E}{R_E} = \frac{0.55 \text{ V}}{680 \Omega} = 809 \mu\text{A}$$
$$I_C \cong 809 \mu\text{A}$$
$$V_{CE} = V_{CC} - I_C R_C - V_E = 15 \text{ V} - (809 \mu\text{A})(1.5 \text{ k}\Omega + 680 \Omega) = 13.2 \text{ V}$$

12. 
$$V_B = \left( \frac{R_2 \parallel \beta_{DC} R_E}{R_1 + R_2 \parallel \beta_{DC} R_E} \right) V_{CC} = \left( \frac{15 \text{ k}\Omega \parallel (110)(1.0 \text{ k}\Omega)}{47 \text{ k}\Omega + 15 \text{ k}\Omega \parallel (110)(1.0 \text{ k}\Omega)} \right) 9 \text{ V} = 1.97 \text{ V}$$

$$V_E = V_B - 0.7 \text{ V} = 1.97 \text{ V} - 0.7 \text{ V} = 1.27 \text{ V}$$

$$I_C \cong I_E = \frac{V_E}{R_E} = \frac{1.27 \text{ V}}{1.0 \text{ k}\Omega} = 1.27 \text{ mA}$$

$$V_C = V_{CC} - I_C R_C = 9 \text{ V} - (1.27 \text{ mA})(2.2 \text{ k}\Omega) = 6.21 \text{ V}$$

13. See Figure 5-2.

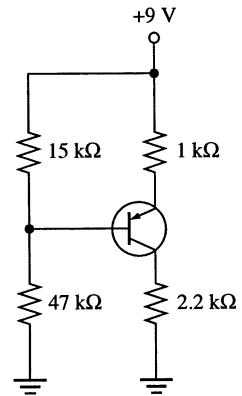

Figure 5-2

14. (a)  $R_{IN(base)} = \beta_{DC} R_E = 50(560 \Omega) = 28 \text{ k}\Omega$

$$V_B = \left( \frac{5.6 \text{ k}\Omega \parallel 28 \text{ k}\Omega}{33 \text{ k}\Omega + 5.6 \text{ k}\Omega \parallel 28 \text{ k}\Omega} \right) (-12 \text{ V}) = \left( \frac{4.67 \text{ k}\Omega}{37.7 \text{ k}\Omega} \right) (-12 \text{ V}) = -1.49 \text{ V}$$

(b)  $R_{IN(base)} = 50(1120 \Omega) = 56 \text{ k}\Omega$

$$V_B = \left( \frac{5.6 \text{ k}\Omega \parallel 56 \text{ k}\Omega}{33 \text{ k}\Omega + 5.6 \text{ k}\Omega \parallel 56 \text{ k}\Omega} \right) (-12 \text{ V}) = \left( \frac{5.09 \text{ k}\Omega}{38.1 \text{ k}\Omega} \right) (-12 \text{ V}) = -1.6 \text{ V}$$

15. (a)  $V_{EQ} = V_B + 0.7 \text{ V} = -1.49 \text{ V} + 0.7 \text{ V} = -0.79 \text{ V}$

$$I_{CQ} \cong I_E = \frac{V_E}{R_E} = \frac{-0.79 \text{ V}}{560 \Omega} = -1.41 \text{ mA}$$

$$V_{CQ} = V_{CC} - I_C R_C = -12 \text{ V} - (-1.41 \text{ mA})(1.8 \text{ k}\Omega) = -9.46 \text{ V}$$

$$V_{CEQ} = V_{CQ} - V_{EQ} = -9.46 \text{ V} - (-0.79 \text{ V}) = -8.67 \text{ V}$$

(b)  $P_{D(min)} = I_{CQ} V_{CEQ} = (-1.41 \text{ mA})(-8.67 \text{ V}) = 12.2 \text{ mW}$

### Section 5-3 Other Bias Methods

16.  $V_{BB} = V_{CC}; V_E = 0 \text{ V}$

$$I_B = \frac{V_{CC} - 0.7 \text{ V}}{R_B} = \frac{12 \text{ V} - 0.7 \text{ V}}{22 \text{ k}\Omega} = \frac{11.3 \text{ V}}{22 \text{ k}\Omega} = 514 \mu\text{A}$$

$$I_C = \beta_{DC} I_B = 90(514 \mu\text{A}) = 46.3 \text{ mA}$$

$$V_{CE} = V_{CC} - I_C R_C = 12 \text{ V} - (46.3 \text{ mA})(100 \Omega) = 7.37 \text{ V}$$

17. 
$$I_{CQ} = 180(514 \mu\text{A}) = 92.5 \text{ mA}$$

$$V_{CEQ} = 12 \text{ V} - (92.5 \text{ mA})(100 \Omega) = 2.75 \text{ V}$$

18.  $I_C$  changes in the circuit with a common  $V_{CC}$  and  $V_{BB}$  supply because a change in  $V_{CC}$  causes  $I_B$  to change which, in turn, changes  $I_C$ .

## Chapter 5

$$19. \quad I_B = \frac{V_{BB} - V_{BE}}{R_B} = \frac{9 \text{ V} - 0.7 \text{ V}}{15 \text{ k}\Omega} = 553 \mu\text{A}$$

$$I_{C(\text{sat})} = \frac{V_{CC}}{R_C} = \frac{9 \text{ V}}{100 \Omega} = 90 \text{ mA}$$

For  $\beta_{DC} = 50$ :

$$I_C = \beta_{DC} I_B = 50(553 \mu\text{A}) = \mathbf{27.7 \text{ mA}}$$

$$V_{CE} = V_{CC} - I_C R_C = 9 \text{ V} - (27.67 \text{ mA})(100 \Omega) = \mathbf{6.23 \text{ V}}$$

For  $\beta_{DC} = 125$ :

$$I_C = \beta_{DC} I_B = 125(553 \mu\text{A}) = \mathbf{69.2 \text{ mA}}$$

$$V_{CE} = V_{CC} - I_C R_C = 9 \text{ V} - (69.2 \text{ mA})(100 \Omega) = \mathbf{2.08 \text{ V}}$$

Since  $I_C < I_{C(\text{sat})}$  for the range of  $\beta_{DC}$ , the circuit remains **biased in the linear region**.

$$20. \quad I_{C(\text{sat})} = \frac{V_{CC}}{R_C} = \frac{9 \text{ V}}{100 \Omega} = 90 \text{ mA}$$

At  $0^\circ\text{C}$ :

$$\beta_{DC} = 110 - 110(0.5) = 55$$

$$I_B = \frac{V_{CC} - V_{BE}}{R_B} = \frac{9 \text{ V} - 0.7 \text{ V}}{15 \text{ k}\Omega} = 553 \mu\text{A}$$

$$I_C = \beta_{DC} I_B = 55(553 \mu\text{A}) = 30.4 \text{ mA}$$

$$V_{CE} = V_{CC} - I_C R_C = 9 \text{ V} - (30.4 \text{ mA})(100 \Omega) = 5.96 \text{ V}$$

At  $70^\circ\text{C}$ :

$$\beta_{DC} = 110 + 110(0.75) = 193$$

$$I_B = 553 \mu\text{A}$$

$$I_C = \beta_{DC} I_B = 193(553 \mu\text{A}) = 107 \text{ mA}$$

$I_C > I_{C(\text{sat})}$ , therefore the transistor is in saturation at  $70^\circ\text{C}$ .

$$\Delta I_C = I_{C(\text{sat})} - I_{C(0^\circ)} = 90 \text{ mA} - 30.4 \text{ mA} = \mathbf{59.6 \text{ mA}}$$

$$\Delta V_{CE} \cong V_{CE(0^\circ)} - V_{CE(\text{sat})} = 5.96 \text{ V} - 0 \text{ V} = \mathbf{5.96 \text{ V}}$$

21. Assuming  $V_B \cong 0 \text{ V}$ ,

$$V_E \cong V_B - V_{BE} = 0 \text{ V} - 0.7 \text{ V} = -0.7 \text{ V}$$

$$I_E \cong \frac{V_E - V_{EE}}{R_E + R_B / \beta_{DC}} = \frac{-0.7 \text{ V} - (-5 \text{ V})}{2.2 \text{ k}\Omega + 22 \text{ k}\Omega / 100} = \frac{4.3 \text{ V}}{2.42 \text{ k}\Omega} = 1.78 \text{ mA}$$

$$I_C \cong I_E$$

$$I_B = \frac{1.78 \text{ mA}}{100} = 17.8 \mu\text{A}$$

$$V_B = (17.8 \mu\text{A})(22 \text{ k}\Omega) = \mathbf{-391 \text{ mV}}$$

$$V_E = -391 \text{ mV} - 0.7 \text{ V} = \mathbf{-1.10 \text{ V}}$$

$$V_C = V_{CC} - I_C R_C = 5 \text{ V} - (1.78 \text{ mA})(1.0 \text{ k}\Omega) = \mathbf{3.22 \text{ V}}$$

22. Assume that at saturation,  $V_{CE} \cong 0 \text{ V}$ .

Since  $V_E = -1.10 \text{ V}$  and  $V_{C(\text{sat})} \cong V_{E(\text{sat})}$

$$I_{C(\text{sat})} = \frac{V_{CC} - V_{C(\text{sat})}}{R_C} = \frac{5 \text{ V} - (-1.10 \text{ V})}{1.0 \text{ k}\Omega} = 6.1 \text{ mA}$$

$$R_{E(\text{min})} \cong \frac{V_{RE}}{I_{C(\text{sat})}} = \frac{3.9 \text{ V}}{6.1 \text{ mA}} = \mathbf{639 \Omega}$$



23. At 100° C:  
 $V_{BE} = 0.7 \text{ V} - (2.5 \text{ mV}/^\circ\text{C})(75^\circ\text{C}) = 0.513 \text{ V}$   
 $I_E = \frac{V_{EE} - V_{BE}}{R_E} = \frac{5 \text{ V} - 0.513 \text{ V}}{2.2 \text{ k}\Omega} = 2.04 \text{ mA}$

At 25° C:  
 $I_E = \frac{5 \text{ V} - 0.7 \text{ V}}{2.2 \text{ k}\Omega} = \frac{4.3 \text{ V}}{2.2 \text{ k}\Omega} = 1.95 \text{ mA}$   
 $\Delta I_E = 2.04 \text{ mA} - 1.95 \text{ mA} = \mathbf{0.09 \text{ mA}}$

24. A change in  $\beta_{DC}$  does not affect the circuit when  $R_E \gg R_B/\beta_{DC}$ .  
 Since

$$I_E = \frac{V_{EE} - V_{BE}}{R_E + R_B / \beta_{DC}}$$

In the equation, if  $R_B/\beta_{DC}$  is much smaller than  $R_E$ , the effect of  $\beta_{DC}$  is negligible.

25. Assume  $\beta_{DC} = 100$ .

$$I_C \cong I_E = \frac{V_{EE} - V_E}{R_E} = \frac{10 \text{ V} - 0.7 \text{ V}}{470 \Omega + 10 \text{ k}\Omega / 100} = \mathbf{16.3 \text{ mA}}$$

$$V_{CE} = V_{EE} - V_{CC} - I_C(R_C + R_E) = 20 \text{ V} - 13.1 \text{ V} = \mathbf{-6.95 \text{ V}}$$

26.  $V_B = 0.7 \text{ V}$

$$I_C = \frac{V_{CC} - V_{BE}}{R_C + R_B / \beta_{DC}} = \frac{3 \text{ V} - 0.7 \text{ V}}{1.8 \text{ k}\Omega + 33 \text{ k}\Omega / 90} = \mathbf{1.06 \text{ mA}}$$

$$V_C = V_{CC} - I_C R_C = 3 \text{ V} - (1.06 \text{ mA})(1.8 \text{ k}\Omega) = \mathbf{1.09 \text{ V}}$$

27.  $I_C = 1.06 \text{ mA}$  from Problem 26.

$$I_C = 1.06 \text{ mA} - (0.25)(1.06 \text{ mA}) = 0.795 \text{ mA}$$

$$I_C = \frac{V_{CC} - V_{BE}}{R_C + R_B / \beta_{DC}}$$

$$R_C = \frac{V_{CC} - V_{BE} - I_C R_B / \beta_{DC}}{I_C} = \frac{3 \text{ V} - 0.7 \text{ V} - (0.795 \text{ mA})(33 \text{ k}\Omega) / 90}{0.795 \text{ mA}} = \mathbf{2.53 \text{ k}\Omega}$$

28.  $I_C = 0.795 \text{ mA}$  from Problem 27.

$$V_{CE} = V_{CC} - I_C R_C = 3 \text{ V} - (0.795 \text{ mA})(2.63 \text{ k}\Omega) = 0.989 \text{ V}$$

$$P_{D(\min)} = V_{CE} I_C = (0.989 \text{ V})(0.795 \text{ mA}) = \mathbf{786 \mu\text{W}}$$

29. See Figure 5-3.

$$I_C = \frac{V_{CC} - V_{BE}}{R_C + R_B / \beta_{DC}} = \frac{12 \text{ V} - 0.7 \text{ V}}{1.2 \text{ k}\Omega + 47 \text{ k}\Omega / 200} = \mathbf{7.87 \text{ mA}}$$

$$V_C = V_{CC} - I_C R_C = 12 \text{ V} - (7.87 \text{ mA})(1.2 \text{ k}\Omega) = \mathbf{2.56 \text{ V}}$$

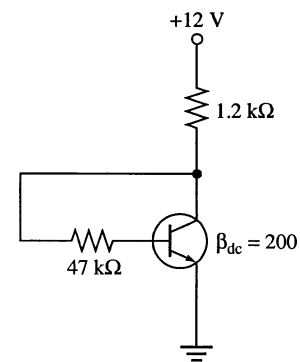

**Figure 5-3**

## Chapter 5

---

### Section 5-4 Troubleshooting

30.  $V_1 = 0.7 \text{ V}$ ,  $V_2 = 0 \text{ V}$

$$I_B = \frac{8 \text{ V} - 0.7 \text{ V}}{33 \text{ k}\Omega} - \frac{0.7 \text{ V}}{10 \text{ k}\Omega} = 221 \mu\text{A} - 70 \mu\text{A} = 151 \mu\text{A}$$

$$I_C = 200(151 \mu\text{A}) = 30.2 \text{ mA}$$

$$I_{C(\text{sat})} = \frac{8 \text{ V}}{2.2 \text{ k}\Omega} = 3.64 \text{ mA}, \text{ so } V_C \cong V_E = 0 \text{ V}$$

If the problem is corrected,

$$V_1 = \left( \frac{10 \text{ k}\Omega}{10 \text{ k}\Omega + 33 \text{ k}\Omega} \right) 8 \text{ V} = 1.86 \text{ V}$$

$$V_2 = V_E = 1.86 \text{ V} - 0.7 \text{ V} = 1.16 \text{ V}$$

$$I_E = \frac{1.16 \text{ V}}{1.0 \text{ k}\Omega} = 1.16 \text{ mA}$$

$$V_3 = V_C = 8 \text{ V} - (1.16 \text{ mA})(2.2 \text{ k}\Omega) = 5.45 \text{ V}$$

31. (a) Open collector  
(b) No problems  
(c) Transistor shorted from collector-to-emitter  
(d) Open emitter

32. For  $\beta_{DC} = 35$ :

$$V_B = \left( \frac{4.5 \text{ k}\Omega}{14.5 \text{ k}\Omega} \right) (-10 \text{ V}) = -3.1 \text{ V}$$

For  $\beta_{DC} = 100$ :

$$V_B = \left( \frac{5.17 \text{ k}\Omega}{15.17 \text{ k}\Omega} \right) (-10 \text{ V}) = -3.4 \text{ V}$$

The measured base voltage at point 4 is within the correct range.

$$V_E = -3.1 \text{ V} + 0.7 \text{ V} = -2.4 \text{ V}$$

$$I_C \cong I_E = \frac{-2.4 \text{ V}}{680 \Omega} = -3.53 \text{ mA}$$

$$V_C = -10 \text{ V} - (-3.53 \text{ mA})(1.0 \text{ k}\Omega) = -6.47 \text{ V}$$

Allowing for some variation in  $V_{BE}$  and for resistor tolerances, the measured collector and emitter voltages are correct.

33. (a) The  $680 \Omega$  resistor is open:

Meter 1: **10 V**

Meter 2: **floating**

$$\text{Meter 3: } V_B = \left( \frac{5.6 \text{ k}\Omega}{15.6 \text{ k}\Omega} \right) (-10 \text{ V}) = -3.59 \text{ V}$$

Meter 4: **10 V**

- (b) The 5.6 kΩ resistor is open.

$$I_B = \frac{9.3 \text{ V}}{10 \text{ k}\Omega + 35(680 \Omega)} = 275 \mu\text{A}$$

$$I_C = 35(275 \mu\text{A}) = 9.6 \text{ mA}$$

$$I_{C(\text{sat})} = \frac{10 \text{ V}}{1680 \Omega} = 5.95 \text{ mA}$$

The transistor is saturated.

Meter 1: **10 V**

Meter 2:  $(5.95 \text{ mA})(680 \Omega) = \mathbf{4.05 \text{ V}}$

Meter 3:  $4.05 \text{ V} + 0.7 \text{ V} = \mathbf{4.75 \text{ V}}$

Meter 4:  $10 \text{ V} - (5.95 \text{ mA})(1.0 \text{ k}\Omega) = \mathbf{4.05 \text{ V}}$

- (c) The 10 kΩ resistor is open. The transistor is off.

Meter 1: **10 V**

Meter 2: **0 V**

Meter 3: **0 V**

Meter 4: **10 V**

- (d) The 1.0 kΩ resistor is open. Collector current is zero.

Meter 1: **10 V**

$$\text{Meter 3: } \left( \frac{5.6 \text{ k}\Omega \parallel 680 \Omega}{10 \text{ k}\Omega + 5.6 \text{ k}\Omega \parallel 680 \Omega} \right) (10 \text{ V}) + 0.7 \text{ V} = 0.57 \text{ V} + 0.7 \text{ V} = \mathbf{1.27 \text{ V}}$$

Meter 2:  $1.27 \text{ V} - 0.7 \text{ V} = \mathbf{0.57 \text{ V}}$

Meter 4: **floating**

- (e) A short from emitter to ground.

Meter 1: **10 V**

Meter 2: **0 V**

Meter 3: **0.7 V**

$$I_B \cong \frac{(10 \text{ V} - 0.7 \text{ V})}{10 \text{ k}\Omega} = \frac{9.3 \text{ V}}{10 \text{ k}\Omega} = 0.93 \text{ mA}$$

$$I_{C(\text{min})} = 35(0.93 \text{ mA}) = 32.6 \text{ mA}$$

$$I_{C(\text{sat})} = \frac{10 \text{ V}}{1.0 \text{ k}\Omega} = 10 \text{ mA}$$

The transistor is saturated.

Meter 4:  $\cong \mathbf{0 \text{ V}}$

- (f) An open base-emitter junction. The transistor is off.

Meter 1: **10 V**

Meter 2: **0 V**

$$\text{Meter 3: } \left( \frac{5.6 \text{ k}\Omega}{15.6 \text{ k}\Omega} \right) (10 \text{ V}) = \mathbf{3.59 \text{ V}}$$

Meter 4: **10 V**

## Chapter 5

### System Application Problems

34. With  $R_1$  shorted:  
 $V_B = 0 \text{ V}$ ,  $V_E = 0 \text{ V}$ ,  $V_C = V_{CC} = 9.1 \text{ V}$
35. Faults that will cause the transistor of textbook Figure 5-30 to go into cutoff:  
 $R_1$  **open**,  $R_2$  **shorted**, base lead or BE junction **open**.
36.  $R_{IN(\text{base})} = 70(470 \Omega) = 32.9 \text{ k}\Omega$   
 $R_{IN} = 2.7 \text{ k}\Omega \parallel 32.9 \text{ k}\Omega = 2.50 \text{ k}\Omega$   
 $V_B = \left( \frac{2.50 \text{ k}\Omega}{2.50 \text{ k}\Omega + 5.6 \text{ k}\Omega} \right) 5.1 \text{ V} = \left( \frac{2.50 \text{ k}\Omega}{8.10 \text{ k}\Omega} \right) 5.1 \text{ V} = 1.57 \text{ V}$   
 $V_E = 1.57 \text{ V} - 0.7 \text{ V} = \mathbf{0.872 \text{ V}}$   
So,  $I_C \cong I_E = \frac{0.872 \text{ V}}{470 \Omega} = \mathbf{1.86 \text{ mA}}$   
 $V_C = 5.1 \text{ V} - (1.86 \text{ mA})(1.0 \text{ k}\Omega) = \mathbf{3.24 \text{ V}}$
37. The following measurements would indicate an open CB junction:  
 $V_C = V_{CC} = \mathbf{+9.1 \text{ V}}$   
 $V_B$  **normal**  
 $V_E \cong \mathbf{0 \text{ V}}$

### Data Sheet Problems

38. For  $T = 45^\circ\text{C}$  and  $R_2 = 2.7 \text{ k}\Omega$   
 $R_{IN(\text{base})} = 2.7 \text{ k}\Omega \parallel (30)(470 \Omega) = 2.7 \text{ k}\Omega \parallel 14.1 \text{ k}\Omega = 2.27 \text{ k}\Omega \text{ min}$   
 $R_{IN(\text{base})} = 2.7 \text{ k}\Omega \parallel (300)(470 \Omega) = 2.7 \text{ k}\Omega \parallel 141 \text{ k}\Omega = 2.65 \text{ k}\Omega \text{ max}$   
 $V_{B(\text{min})} = \left( \frac{2.27 \text{ k}\Omega}{2.27 \text{ k}\Omega + 5.6 \text{ k}\Omega} \right) 9.1 \text{ V} = \left( \frac{2.27 \text{ k}\Omega}{7.87} \right) 9.1 \text{ V} = \mathbf{2.62 \text{ V}}$   
 $V_{E(\text{min})} = 2.62 \text{ V} - 0.7 \text{ V} = \mathbf{1.92 \text{ V}}$   
So,  $I_C \cong I_E = \frac{1.92 \text{ V}}{470 \Omega} = 4.09 \text{ mA}$   
 $V_{C(\text{max})} = 9.1 \text{ V} - (4.09 \text{ mA})(1.0 \text{ k}\Omega) = \mathbf{5.01 \text{ V}}$   
 $V_{B(\text{max})} = \left( \frac{2.65 \text{ k}\Omega}{2.65 \text{ k}\Omega + 5.6 \text{ k}\Omega} \right) 9.1 \text{ V} = \left( \frac{2.65 \text{ k}\Omega}{8.25 \text{ k}\Omega} \right) 9.1 \text{ V} = \mathbf{2.92 \text{ V}}$   
 $V_{E(\text{max})} = 2.92 \text{ V} - 0.7 \text{ V} = \mathbf{2.22 \text{ V}}$   
So,  $I_C \cong I_E = \frac{2.22 \text{ V}}{470 \Omega} = 4.73 \text{ mA}$   
 $V_{C(\text{min})} = 9.1 \text{ V} - (4.73 \text{ mA})(1.0 \text{ k}\Omega) = \mathbf{4.37 \text{ V}}$

For  $T = 55^\circ\text{C}$  and  $R_2 = 1.24 \text{ k}\Omega$ :

$$R_{\text{IN(base)}} = 1.24 \text{ k}\Omega \parallel (30)(470 \Omega) = 1.24 \text{ k}\Omega \parallel 14.1 \text{ k}\Omega = 1.14 \text{ k}\Omega \text{ min}$$

$$R_{\text{IN(base)}} = 1.24 \text{ k}\Omega \parallel (300)(470 \Omega) = 1.24 \text{ k}\Omega \parallel 141 \text{ k}\Omega = 1.23 \text{ k}\Omega \text{ max}$$

$$V_{\text{B(min)}} = \left( \frac{1.14 \text{ k}\Omega}{1.14 \text{ k}\Omega + 5.6 \text{ k}\Omega} \right) 9.1 \text{ V} = \left( \frac{1.14 \text{ k}\Omega}{6.74 \text{ k}\Omega} \right) 9.1 \text{ V} = 1.54 \text{ V}$$

$$V_{\text{E(min)}} = 1.54 \text{ V} - 0.7 \text{ V} = \mathbf{0.839 \text{ V}}$$

$$\text{So, } I_{\text{C}} \cong I_{\text{E}} = \frac{0.839 \text{ V}}{470 \Omega} = 1.78 \text{ mA}$$

$$V_{\text{C(max)}} = 9.1 \text{ V} - (1.78 \text{ mA})(1.0 \text{ k}\Omega) = \mathbf{7.32 \text{ V}}$$

$$V_{\text{B(max)}} = \left( \frac{1.23 \text{ k}\Omega}{1.23 \text{ k}\Omega + 5.6 \text{ k}\Omega} \right) 9.1 \text{ V} = \left( \frac{1.23 \text{ k}\Omega}{6.83 \text{ k}\Omega} \right) 9.1 \text{ V} = 1.64 \text{ V}$$

$$V_{\text{E(max)}} = 1.64 \text{ V} - 0.7 \text{ V} = \mathbf{0.938 \text{ V}}$$

$$\text{So, } I_{\text{C}} \cong I_{\text{E}} = \frac{0.938 \text{ V}}{470 \Omega} = 2.0 \text{ mA}$$

$$V_{\text{C(min)}} = 9.1 \text{ V} - (2.0 \text{ mA})(1.0 \text{ k}\Omega) = \mathbf{7.10 \text{ V}}$$

39. At  $T = 45^\circ\text{C}$  for minimum  $\beta_{\text{DC}}$ :  
 $P_{\text{D(max)}} = (5.01 \text{ V} - 1.92 \text{ V})(4.09 \text{ mA}) = (3.09 \text{ V})(4.09 \text{ mA}) = 12.6 \text{ mW}$   
 At  $T = 55^\circ\text{C}$  for minimum  $\beta_{\text{DC}}$ :  
 $P_{\text{D(max)}} = (7.32 \text{ V} - 0.839 \text{ V})(1.78 \text{ mA}) = (6.48 \text{ V})(1.78 \text{ mA}) = 11.5 \text{ mW}$   
 For maximum beta values, the results are comparable and nowhere near the maximum.  
 $P_{\text{D(max)}} = 625 \text{ mW} - (5.0 \text{ m}^\circ\text{C})(30^\circ\text{C}) = 475 \text{ mW}$   
**No ratings are exceeded.**
40. For the data sheet of Figure 5-51 in the textbook:  
 (a) For a 2N2222A,  $I_{\text{C(max)}} = \mathbf{800 \text{ mA}}$  continuous  
 (b) For a 2N2118,  $V_{\text{BE(max)}} = \mathbf{5.0 \text{ V}}$  for reverse breakdown or  $V_{\text{BE(max)}} = \mathbf{2.6 \text{ V}}$  for saturation
41. For a 2N2222 @  $T = 100^\circ\text{C}$ :  
 $P_{\text{D(max)}} = 0.8 \text{ W} - (4.57 \text{ mW}/^\circ\text{C})(100^\circ\text{C} - 25^\circ\text{C}) = 0.8 \text{ W} - 343 \text{ mW} = \mathbf{457 \text{ mW}}$
42. If  $I_{\text{C}}$  changes from 1 mA to 500 mA in a 2N2219, the percentage change in  $\beta_{\text{DC}}$  is  
 $\Delta\beta_{\text{DC}} = \left( \frac{30 - 50}{50} \right) 100\% = \mathbf{-40\%}$

### Advanced Problems

43. See Figure 5-4.

$$R_{\text{C}} = \frac{V_{\text{CC}} - V_{\text{CEQ}}}{I_{\text{CQ}}} = \frac{15 \text{ V} - 5 \text{ V}}{5 \text{ mA}} = 2 \text{ k}\Omega$$

Assume  $\beta_{\text{DC}} = 100$ .

$$I_{\text{BQ}} = \frac{I_{\text{CQ}}}{\beta_{\text{DC}}} = \frac{5 \text{ mA}}{100} = 50 \mu\text{A}$$

$$R_{\text{B}} = \frac{V_{\text{CC}} - V_{\text{BE}}}{I_{\text{BQ}}} = \frac{15 \text{ V} - 0.7 \text{ V}}{50 \mu\text{A}} = 286 \text{ k}\Omega$$

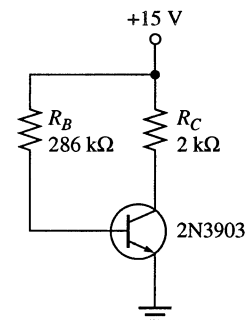

Figure 5-4

# Chapter 5

44. See Figure 5-5.  
Assume  $\beta_{DC} = 200$ .

$$I_{BQ} = \frac{I_{CQ}}{\beta_{DC}} = \frac{10 \text{ mA}}{200} = 50 \mu\text{A}$$

$$\text{Let } R_B = 1.0 \text{ k}\Omega$$

$$R_E = \frac{12 \text{ V} - (50 \mu\text{A})(1.0 \text{ k}\Omega) - 0.7 \text{ V}}{10 \text{ mA}} = \frac{11.3 \text{ V}}{10 \text{ mA}} = 1.13 \text{ k}\Omega$$

$$R_C = \frac{12 \text{ V} - (-12 \text{ V} + 11.3 \text{ V} + 4 \text{ V})}{10 \text{ mA}} = \frac{8.7 \text{ V}}{10 \text{ mA}} = 870 \Omega$$

870  $\Omega$  and 1.13 k $\Omega$  are not standard values.  $R_C = 820 \Omega$  and  $R_E = 1.2 \text{ k}\Omega$  give  $I_{CQ} \cong 9.38 \text{ mA}$ ,  $V_{CEQ} \cong 5.05 \text{ V}$ .

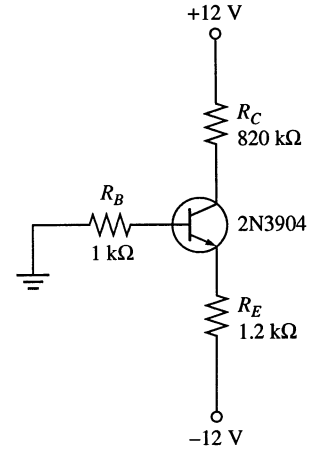

Figure 5-5

45. See Figure 5-6.  
 $\beta_{DC(\min)} \cong 70$ . Let  $R_E = 1.0 \text{ k}\Omega$ .

$$V_E = I_E R_E = 1.5 \text{ mA}(1.0 \text{ k}\Omega) = 1.5 \text{ V}$$

$$V_B = 1.5 \text{ V} + 0.7 \text{ V} = 2.2 \text{ V}$$

$$R_C = \frac{V_{CC} - V_{CEQ} - V_E}{I_{CQ}} = \frac{9 \text{ V} - 1.5 \text{ V} - 3 \text{ V}}{1.5 \text{ mA}} = 3 \text{ k}\Omega$$

$$R_1 + R_2 = \frac{V_{CC}}{I_{CC(\max)} - I_{CQ}} = \frac{9 \text{ V}}{5 \text{ mA} - 1.5 \text{ mA}} = 2.57 \text{ k}\Omega \text{ min}$$

Assuming  $\beta_{DC} R_E \gg R_2$ ,

$$\frac{R_1}{R_2} = \frac{6.8 \text{ V}}{2.2 \text{ V}} = 3.09$$

$$R_1 = 3.09 R_2$$

$$R_1 + R_2 = R_2 + 3.09 R_2 = 2.57 \text{ k}\Omega$$

$$4.09 R_2 = 2.57 \text{ k}\Omega$$

$$R_2 = \frac{2.57 \text{ k}\Omega}{4.09} = 628 \Omega$$

So,  $R_2 \cong 620$  and  $R_1 = 1.92 \text{ k}\Omega \cong 2 \text{ k}\Omega$ .

From this,

$$R_{IN(\text{base})} = 70(1.0 \text{ k}\Omega) = 70 \text{ k}\Omega \gg R_2$$

$$\text{so, } V_B = \left( \frac{620 \Omega}{2.62 \text{ k}\Omega} \right) 9 \text{ V} = 2.13 \text{ V}$$

$$V_E = 2.13 \text{ V} - 0.7 \text{ V} = 1.43 \text{ V}$$

$$I_{CQ} \cong I_E = \frac{1.43 \text{ V}}{1.0 \text{ k}\Omega} = 1.43 \text{ mA}$$

$$V_{CEQ} = 9 \text{ V} - (1.43 \text{ mA})(1.0 \text{ k}\Omega + 3 \text{ k}\Omega) = 3.28 \text{ V}$$

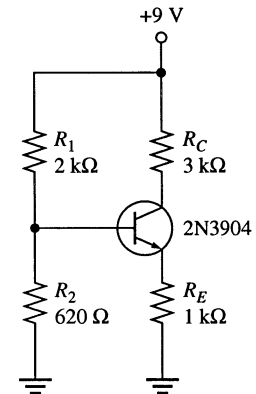

Figure 5-6

46. See Figure 5-7.

$$\beta_{DC} \cong 75.$$

$$I_{BQ} = \frac{10 \text{ mA}}{75} = 133 \mu\text{A}$$

$$R_C = \frac{V_{CC} - V_{CE}}{I_{CQ}} = \frac{5 \text{ V} - 1.5 \text{ V}}{10 \text{ mA}} = 350 \Omega \text{ (use } 360 \Omega \text{)}$$

$$R_B = \frac{V_{CE} - 0.7 \text{ V}}{I_{BQ}} = \frac{1.55 \text{ V} - 0.7 \text{ V}}{133 \mu\text{A}} = 6 \text{ k}\Omega \text{ (use } 6.2 \text{ k}\Omega \text{)}$$

$$I_{CQ} = \frac{5 \text{ V} - 0.7 \text{ V}}{360 \Omega + 6.2 \text{ k}\Omega / 75} = 9.71 \text{ mA}$$

$$V_{CEQ} = V_C = 5 \text{ V} - (9.71 \text{ mA})(360 \Omega) = 1.50 \text{ V}$$

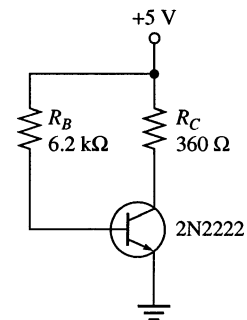

**Figure 5-7**

47. The 2N3904 in textbook Figure 5-49 **can be replaced** with a 2N2222 and maintain the same voltage range from 45°C to 55°C because the voltage-divider circuit is essentially  $\beta$  independent and the  $\beta_{DC}$  parameters of the two transistors are comparable.
48. For the 2N2222 using the data sheet of Figure 5-51 and Figure 5-52 at  $I_C = 150 \text{ mA}$  and  $V_{CE} = 1.0 \text{ V}$ :  
 At  $T = -55^\circ\text{C}$ ,  $h_{FE(\text{min})} = (0.45)(50) = \mathbf{22.5}$   
 At  $T = 25^\circ\text{C}$ ,  $h_{FE(\text{min})} = (0.63)(50) = \mathbf{31.5}$   
 At  $T = 175^\circ\text{C}$ ,  $h_{FE(\text{min})} = (0.53)(50) = \mathbf{26.6}$
49. If the ADC loading of the temperature conversion circuit changes from 100 kΩ to 10 kΩ, the Q-point will have a reduced  $V_{CEQ}$  because the current through  $R_C$  will consist of the same  $I_C$  and a larger  $I_L$ .  $I_{CQ}$  is unaffected in the sense that the transistor collector current is the same, although the collector resistance current is larger. The transistor saturates sooner so that lower temperatures do not register as well, if at all.
50. It is not feasible to operate the circuit from a 5.1 V dc supply and maintain the same range of output voltages because the output voltage at 54°C is 7.06 V.

## EWB/Multisim Troubleshooting Problems

The solutions showing instrument connections for Problems 51 through 56 are available in the Solutions folder for Chapter 5 on the CD-ROM provided with the textbook. The solutions may be accessed using the password *ED5FLOYD*. The faults in the circuit files may be accessed using the password *book* (all lowercase).

51.  $R_C$  open
52.  $R_B$  open
53.  $R_2$  open
54. Collector-emitter shorted
55.  $R_C$  shorted
56. Base-emitter open

# Chapter 6

## BJT Amplifiers

---

### Section 6-1 Amplifier Operation

1. Approximately 1 mA
2. From the graph of Figure 6-4, the highest value of dc collector current is about 6 mA.

### Section 6-2 Transistor AC Equivalent Circuits

$$3. \quad r'_e = \frac{25 \text{ mV}}{I_E} = \frac{25 \text{ mV}}{3 \text{ mA}} = 8.33 \Omega$$

$$4. \quad \beta_{ac} = h_{fe} = 200$$

$$5. \quad I_C = \beta_{DC} I_B = 130(10 \mu\text{A}) = 1.3 \text{ mA}$$

$$I_E = \frac{I_C}{\alpha_{DC}} = \frac{1.3 \text{ mA}}{0.99} = 1.31 \text{ mA}$$

$$r'_e = \frac{25 \text{ mV}}{I_E} = \frac{25 \text{ mV}}{1.31 \text{ mA}} = 19 \Omega$$

$$6. \quad \beta_{DC} = \frac{I_C}{I_B} = \frac{2 \text{ mA}}{15 \mu\text{A}} = 133$$

$$\beta_{ac} = \frac{\Delta I_C}{\Delta I_B} = \frac{0.35 \text{ mA}}{3 \mu\text{A}} = 117$$

### Section 6-3 The Common-Emitter Amplifier

7. See Figure 6-1.

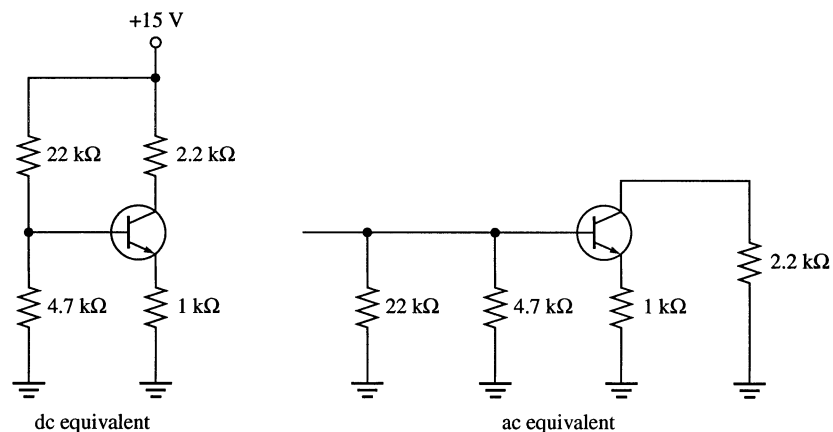

Figure 6-1



8. (a)  $V_B = \left( \frac{4.7 \text{ k}\Omega}{4.7 \text{ k}\Omega + 22 \text{ k}\Omega} \right) 15 \text{ V} = 2.64 \text{ V}$   
 $V_E = 2.64 \text{ V} - 0.7 \text{ V} = 1.94 \text{ V}$   
 $I_E = \frac{1.94 \text{ V}}{1.0 \text{ k}\Omega} = 1.94 \text{ mA}$   
 $r'_e \cong \frac{25 \text{ mV}}{I_E} = \frac{25 \text{ mV}}{1.94 \text{ mA}} = 12.9 \Omega$   
 $R_{in(base)} = \beta_{ac}(r'_e + R_E) = 100(1012.9 \Omega) \cong 101 \text{ k}\Omega$
- (b)  $R_{in} = R_{in(base)} \parallel R_1 \parallel R_2 = 101 \text{ k}\Omega \parallel 22 \text{ k}\Omega \parallel 4.7 \text{ k}\Omega = 3.73 \text{ k}\Omega$
- (c)  $A_v = \frac{R_C}{R_E + r'_e} = \frac{2.2 \text{ k}\Omega}{12.02 \Omega} = 2.17$
9. (a)  $R_{in(base)} = \beta_{ac}r'_e = 100(12.9 \Omega) = 1.29 \text{ k}\Omega$
- (b)  $R_{in} = 1.29 \text{ k}\Omega \parallel 22 \text{ k}\Omega \parallel 4.7 \text{ k}\Omega = 968 \Omega$
- (c)  $A_v = \frac{R_C}{r'_e} = \frac{2.2 \text{ k}\Omega}{12.9 \Omega} = 171$
10. (a)  $R_{in(base)} = \beta_{ac}r'_e = 100(12.9 \Omega) = 1.29 \text{ k}\Omega$
- (b)  $R_{in} = 1.29 \text{ k}\Omega \parallel 22 \text{ k}\Omega \parallel 4.7 \text{ k}\Omega = 968 \Omega$
- (c)  $A_v = \frac{R_C}{r'_e} = \frac{R_C \parallel R_L}{r'_e} = \frac{2.2 \text{ k}\Omega \parallel 10 \text{ k}\Omega}{12.9 \Omega} = 140$
11. (a)  $V_B = \left( \frac{R_2 \parallel \beta_{DC}R_E}{R_1 + R_2 \parallel \beta_{DC}R_E} \right) V_{CC} = \left( \frac{12 \text{ k}\Omega \parallel 75(1.0 \text{ k}\Omega)}{47 \text{ k}\Omega + 12 \text{ k}\Omega \parallel 75(1.0 \text{ k}\Omega)} \right) 18 \text{ V} = 3.25 \text{ V}$
- (b)  $V_E = V_B - 0.7 \text{ V} = 2.55 \text{ V}$
- (c)  $I_E = \frac{V_E}{R_E} = \frac{2.55 \text{ V}}{1.0 \text{ k}\Omega} = 2.55 \text{ mA}$
- (d)  $I_C \cong I_E = 2.55 \text{ mA}$
- (e)  $V_C = V_{CC} - I_C R_C = 18 \text{ V} - (2.55 \text{ mA})(3.3 \text{ k}\Omega) = 9.59 \text{ V}$
- (f)  $V_{CE} = V_C - V_E = 9.59 \text{ V} - 2.55 \text{ V} = 7.04 \text{ V}$
12. From Problem 11,  $I_E = 2.55 \text{ mA}$
- (a)  $R_{in(base)} = \beta_{ac}r'_e \cong \beta_{ac} \left( \frac{25 \text{ mV}}{I_E} \right) = 70 \left( \frac{25 \text{ mV}}{2.55 \text{ mA}} \right) = 686 \Omega$
- (b)  $R_{in} = R_1 \parallel R_2 \parallel R_{in(base)} = 47 \text{ k}\Omega \parallel 12 \text{ k}\Omega \parallel 686 \Omega = 640 \Omega$
- (c)  $A_v = \frac{R_C \parallel R_L}{r'_e} = \frac{3.3 \text{ k}\Omega \parallel 10 \text{ k}\Omega}{9.8 \Omega} = 253$
- (d)  $A_i = \beta_{ac} = 70$
- (e)  $A_p = A_v A_i = (253)(70) = 17,710$

## Chapter 6

$$13. \quad V_b = \left( \frac{R_{in}}{R_{in} + R_s} \right) V_{in} = \left( \frac{640 \Omega}{640 \Omega + 600 \Omega} \right) 12 \mu\text{V}$$

Attenuation of the input network is

$$\left( \frac{R_{in}}{R_{in} + R_s} \right) = \left( \frac{640 \Omega}{640 \Omega + 600 \Omega} \right) = 0.516$$

$$A'_v = 0.516 A_v = 0.516(253) = 131$$

$$\theta = 180^\circ$$

$$14. \quad V_B = \left( \frac{R_2 \parallel \beta_{DC} R_E}{R_1 + R_2 \parallel \beta_{DC} R_E} \right) V_{CC} = \left( \frac{3.3 \text{ k}\Omega \parallel 150(100 \Omega)}{12 \text{ k}\Omega + 3.3 \text{ k}\Omega \parallel 150(100 \Omega)} \right) 8 \text{ V} = 1.47 \text{ V}$$

$$I_E = \frac{V_B - 0.7 \text{ V}}{R_E} = \frac{1.47 \text{ V} - 0.7 \text{ V}}{100 \Omega} = 7.7 \text{ mA}$$

$$r'_e = \frac{25 \text{ mV}}{I_E} = \frac{25 \text{ mV}}{7.7 \text{ mA}} = 3.25 \Omega$$

$$A_{v(\min)} = \frac{R_C}{R_E + r'_e} = \frac{330 \Omega}{100 \Omega + 3.25 \Omega} = 3.2$$

$$A_{v(\max)} = \frac{R_C}{r'_e} = \frac{330 \Omega}{3.25 \Omega} = 102$$

15. Maximum gain is at  $R_e = 0 \Omega$ .

$$R_{IN(\text{base})} = \beta_{DC} R_E = 150(100 \Omega) = 15 \text{ k}\Omega$$

$$V_B = \left( \frac{R_2 \parallel R_{IN(\text{base})}}{R_1 + R_2 \parallel R_{IN(\text{base})}} \right) V_{CC} = \left( \frac{3.3 \text{ k}\Omega \parallel 15 \text{ k}\Omega}{12 \text{ k}\Omega + 3.3 \text{ k}\Omega \parallel 15 \text{ k}\Omega} \right) 8 \text{ V} = 1.47 \text{ V}$$

$$I_E = \frac{V_B - V_{BE}}{R_E} = \frac{1.47 \text{ V} - 0.7 \text{ V}}{100 \Omega} = 7.7 \text{ mA}$$

$$r'_e \cong \frac{25 \text{ mV}}{7.7 \text{ mA}} = 3.25 \Omega$$

$$A_{v(\max)} = \frac{R_C \parallel R_L}{r'_e} = \frac{330 \Omega \parallel 600 \Omega}{3.25 \Omega} = 65.5$$

Minimum gain is at  $R_e = 100 \Omega$ .

$$A_{v(\min)} = \frac{R_C \parallel R_L}{R_E + r'_e} = \frac{212.9 \Omega}{103.25 \Omega} = 2.06$$

16.  $R_{in} = R_1 \parallel R_2 \parallel \beta_{ac} r'_e = 3.3 \text{ k}\Omega \parallel 12 \text{ k}\Omega \parallel 150(3.25 \Omega) = 410 \Omega$

Attenuation of the input network is

$$\frac{R_{in}}{R_{in} + R_s} = \frac{410 \Omega}{410 \Omega + 300 \Omega} = 0.5777$$

$$A_v = \frac{R_c}{r'_e} = \frac{330 \Omega \parallel 1.0 \text{ k}\Omega}{3.25 \Omega} = 76.3$$

$$A'_v = 0.5777 A_v = 0.5777(76.3) = 44$$

17. See Figure 6-2.

$$r'_e \cong \frac{25 \text{ mV}}{2.55 \text{ mA}} = 9.8 \Omega$$

$$R_e \geq 10r'_e$$

Set  $R_e = 100 \Omega$ .

The gain is reduced to

$$A_v = \frac{R_C}{R_e + r'_e} = \frac{3.3 \text{ k}\Omega}{109.8 \Omega} = 30.1$$

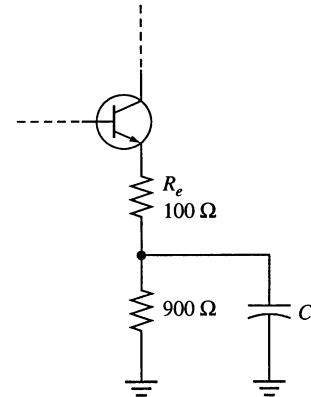

Figure 6-2

### Section 6-4 The Common-Collector Amplifier

18.  $V_B = \left( \frac{R_2}{R_1 + R_2} \right) V_{CC} = \left( \frac{4.7 \text{ k}\Omega}{14.7 \text{ k}\Omega} \right) 5.5 \text{ V} = 1.76 \text{ V}$

$$I_E = \frac{V_B - 0.7 \text{ V}}{R_E} = \frac{1.76 \text{ V} - 0.7 \text{ V}}{1.0 \text{ k}\Omega} = 1.06 \text{ mA}$$

$$r'_e \cong \frac{25 \text{ mV}}{1.06 \text{ mA}} = 23.6 \Omega$$

$$A_v = \frac{R_E}{R_E + r'_e} = \frac{1.0 \text{ k}\Omega}{1.0 \text{ k}\Omega + 23.6 \Omega} = 0.977$$

19.  $R_{in} = R_1 \parallel R_2 \parallel \beta_{ac}(r'_e + R_E) \cong R_1 \parallel R_2 \parallel \beta_{ac} R_E = 10 \text{ k}\Omega \parallel 4.7 \text{ k}\Omega \parallel 100 \text{ k}\Omega = 3.1 \text{ k}\Omega$

$$V_{OUT} = V_B - 0.7 \text{ V} = \left( \frac{R_2}{R_1 + R_2} \right) V_{CC} - 0.7 \text{ V} = \left( \frac{4.7 \text{ k}\Omega}{14.7 \text{ k}\Omega} \right) 5.5 \text{ V} - 0.7 \text{ V} = 1.06 \text{ V}$$

20. The voltage gain is **reduced** because  $A_v = \frac{R_e}{R_e + r'_e}$ .

## Chapter 6

21. 
$$V_B = \left( \frac{R_2}{R_1 + R_2} \right) V_{CC} = \left( \frac{4.7 \text{ k}\Omega}{14.7 \text{ k}\Omega} \right) 5.5 \text{ V} = 1.76 \text{ V}$$

$$I_E = \frac{V_B - V_{BE}}{R_E} = \frac{1.76 \text{ V} - 0.7 \text{ V}}{1.0 \text{ k}\Omega} = 1.06 \text{ mA}$$

$$r'_e \cong \frac{25 \text{ mV}}{I_E} = \frac{25 \text{ mV}}{1.06 \text{ mA}} = 23.6 \Omega$$

$$A_v = \frac{R_E \parallel R_L}{r'_e + R_E \parallel R_L}$$

$$A_v(r'_e + R_E \parallel R_L) = R_E \parallel R_L$$

$$R_E \parallel R_L - A_v(R_E \parallel R_L) = A_v r'_e$$

$$(R_E \parallel R_L)(1 - A_v) = A_v r'_e$$

$$(R_E \parallel R_L) = \frac{A_v r'_e}{(1 - A_v)} = \frac{0.9(23.6 \Omega)}{1 - 0.9} = 212.4 \Omega$$

$$R_L R_E = 212.4 R_L + 212.4 R_E$$

$$R_L R_E - 212.4 R_L = 212.4 R_E$$

$$R_L = \frac{212.4 R_E}{R_E - 212.4} = \frac{(212.4 \Omega)(1000 \Omega)}{1000 \Omega - 212.4 \Omega} = 270 \Omega$$

22. (a)  $V_{C1} = 10 \text{ V}$

$$V_{B1} = \left( \frac{R_2}{R_1 + R_2} \right) V_{CC} = \left( \frac{22 \text{ k}\Omega}{55 \text{ k}\Omega} \right) 10 \text{ V} = 4 \text{ V}$$

$$V_{E1} = V_{B1} - 0.7 \text{ V} = 4 \text{ V} - 0.7 \text{ V} = 3.3 \text{ V}$$

$$V_{C2} = 10 \text{ V}$$

$$V_{B2} = V_{E1} = 3.3 \text{ V}$$

$$V_{E2} = V_{B2} - 0.7 \text{ V} = 3.3 \text{ V} - 0.7 \text{ V} = 2.6 \text{ V}$$

(b)  $\beta'_{DC} = \beta_{DC1} \beta_{DC2} = (150)(100) = 15,000$

(c) 
$$I_{E1} = \frac{V_{E1}}{\beta_{DC2} R_E} = \frac{3.3 \text{ V}}{(100)(1.5 \text{ k}\Omega)} = 22 \mu\text{A}$$

$$r'_{e1} \cong \frac{25 \text{ mV}}{I_{E1}} = \frac{25 \text{ mV}}{22 \mu\text{A}} = 1.14 \text{ k}\Omega$$

$$I_{E2} = \frac{V_{E2}}{R_E} = \frac{2.6 \text{ V}}{1.5 \text{ k}\Omega} = 1.73 \text{ mA}$$

$$r'_{e2} \cong \frac{25 \text{ mV}}{I_{E2}} = \frac{25 \text{ mV}}{1.73 \text{ mA}} = 14.5 \Omega$$

(d)  $R_{in} = R_1 \parallel R_2 \parallel R_{in(\text{base1})}$

$$R_{in(\text{base1})} = \beta_{ac1} \beta_{ac2} R_E = (150)(100)(1.5 \text{ k}\Omega) = 22.5 \text{ M}\Omega$$

$$R_{in} = 33 \text{ k}\Omega \parallel 22 \text{ k}\Omega \parallel 22.5 \text{ M}\Omega = 13.2 \text{ k}\Omega$$

23.  $R_{in(base)} = \beta_{ac1}\beta_{ac2}R_E = (150)(100)(1.5 \text{ k}\Omega) = 22.5 \text{ M}\Omega$   
 $R_{in} = R_2 \parallel R_1 \parallel R_{in(base)} = 22 \text{ k}\Omega \parallel 33 \text{ k}\Omega \parallel 22.5 \text{ M}\Omega = 13.2 \text{ k}\Omega$   
 $I_{in} = \frac{V_{in}}{R_{in}} = \frac{1 \text{ V}}{13.2 \text{ k}\Omega} = 75.8 \text{ }\mu\text{A}$   
 $I_{in(base1)} = \frac{V_{in}}{R_{in(base1)}} = \frac{1 \text{ V}}{22.5 \text{ M}\Omega} = 44.4 \text{ nA}$   
 $I_e \cong \beta_{ac1}\beta_{ac2}I_{in(base1)} = (150)(100)(44.4 \text{ nA}) = 667 \text{ }\mu\text{A}$   
 $A'_i = \frac{I_e}{I_{in}} = \frac{667 \text{ }\mu\text{A}}{75.8 \text{ }\mu\text{A}} = 8.8$

### Section 6-5 The Common-Base Amplifier

24. The main disadvantage of a common-base amplifier is **low input impedance**. Another disadvantage is **unity current gain**.

25.  $V_E = \left( \frac{R_2}{R_1 + R_2} \right) V_{CC} - V_{BE} = \left( \frac{10 \text{ k}\Omega}{32 \text{ k}\Omega} \right) 24 \text{ V} - 0.7 \text{ V} = 6.8 \text{ V}$   
 $I_E = \frac{6.8 \text{ V}}{620 \text{ }\Omega} = 10.97 \text{ mA}$   
 $R_{in(emitter)} = r'_e \cong \frac{25 \text{ mV}}{I_E} = \frac{25 \text{ mA}}{10.97 \text{ mA}} = 2.28 \text{ }\Omega$   
 $A_v = \frac{R_C}{r'_e} = \frac{1.2 \text{ k}\Omega}{2.28 \text{ }\Omega} = 526$   
 $A_i \cong 1$   
 $A_p = A_i A_v \cong 526$

26. (a) Common-base (b) Common-emitter (c) Common-collector

### Section 6-6 Multistage Amplifiers

27.  $A'_v = A_{v1}A_{v2} = (20)(20) = 400$

28.  $A'_{v(\text{dB})} = 10 \text{ dB} + 10 \text{ dB} + 10 \text{ dB} = 30 \text{ dB}$   
 $20 \log A'_v = 30 \text{ dB}$   
 $\log A'_v = \frac{30}{20} = 1.5$   
 $A'_v = 31.6$

## Chapter 6

29. (a)  $V_E = \left( \frac{R_2}{R_1 + R_2} \right) V_{CC} - V_{BE} = \left( \frac{8.2 \text{ k}\Omega}{33 \text{ k}\Omega + 8.2 \text{ k}\Omega} \right) 15 \text{ V} - 0.7 \text{ V} = 2.29 \text{ V}$

$$I_E = \frac{V_E}{R_E} = \frac{2.29 \text{ V}}{1.0 \text{ k}\Omega} = 2.29 \text{ mA}$$

$$r'_e \cong \frac{25 \text{ mV}}{I_E} = \frac{25 \text{ mV}}{2.29 \text{ mA}} = 10.9 \Omega$$

$$R_{in(2)} = R_5 \parallel R_4 \parallel \beta_{ac} r'_e = 8.2 \text{ k}\Omega \parallel 33 \text{ k}\Omega \parallel 175(10.9 \Omega) = 1.48 \text{ k}\Omega$$

$$A_{v1} = \frac{R_C \parallel R_{in(2)}}{r'_e} = \frac{3.3 \text{ k}\Omega \parallel 1.48 \text{ k}\Omega}{10.9 \Omega} = 93.6$$

$$A_{v2} = \frac{R_C}{r'_e} = \frac{3.3 \text{ k}\Omega}{10.9 \Omega} = 302$$

(b)  $A'_v = A_{v1} A_{v2} = (93.6)(302) = 28,267$

(c)  $A_{v1(\text{dB})} = 20 \log(93.6) = 39.4 \text{ dB}$

$$A_{v2(\text{dB})} = 20 \log(302) = 49.6 \text{ dB}$$

$$A'_{v(\text{dB})} = 20 \log(28,267) = 89.0 \text{ dB}$$

30. (a)  $A_{v1} = \frac{R_C \parallel R_{in(2)}}{r'_e} = \frac{3.3 \text{ k}\Omega \parallel 1.48 \text{ k}\Omega}{10.9 \Omega} = 93.6$

$$A_{v2} = \frac{R_C \parallel R_L}{r'_e} = \frac{3.3 \text{ k}\Omega \parallel 18 \text{ k}\Omega}{10.9 \Omega} = 255$$

(b)  $R_{in(1)} = R_1 \parallel R_2 \parallel r'_e = 33 \text{ k}\Omega \parallel 8.2 \text{ k}\Omega \parallel 175(10.9 \Omega) = 1.48 \text{ k}\Omega$

Attenuation of the input network is

$$\frac{R_{in(1)}}{R_{in(1)} + R_s} = \frac{1.48 \text{ k}\Omega}{1.48 \text{ k}\Omega + 75 \Omega} = 0.95$$

$$A'_v = (0.95)A_{v1}A_{v2} = (0.95)(93.6)(255) = 22,675$$

(c)  $A_{v1(\text{dB})} = 20 \log(93.6) = 39.4 \text{ dB}$

$$A_{v2(\text{dB})} = 20 \log(255) = 48.1 \text{ dB}$$

$$A'_{v(\text{dB})} = 20 \log(22,675) = 87.1 \text{ dB}$$

31.  $V_{B1} = \left( \frac{R_2}{R_1 + R_2} \right) V_{CC} = \left( \frac{22 \text{ k}\Omega}{122 \text{ k}\Omega} \right) 12 \text{ V} = 2.16 \text{ V}$

$$V_{E1} = V_{B1} - 0.7 \text{ V} = 1.46 \text{ V}$$

$$I_{C1} \cong I_{E1} = \frac{V_{E1}}{R_4} = \frac{1.46 \text{ V}}{4.7 \text{ k}\Omega} = 0.311 \text{ mA}$$

$$V_{C1} = V_{CC} - I_{C1}R_3 = 12 \text{ V} - (0.311 \text{ mA})(22 \text{ k}\Omega) = 5.16 \text{ V}$$

$$V_{B2} = V_{C1} = 5.16 \text{ V}$$

$$V_{E2} = V_{B2} - 0.7 \text{ V} = 5.16 \text{ V} - 0.7 \text{ V} = 4.46 \text{ V}$$

$$I_{C2} \cong I_{E2} = \frac{V_{E2}}{R_6} = \frac{4.46 \text{ V}}{10 \text{ k}\Omega} = 0.446 \text{ mA}$$

$$V_{C2} = V_{CC} - I_{C2}R_5 = 12 \text{ V} - (0.446 \text{ mA})(10 \text{ k}\Omega) = \mathbf{7.54 \text{ V}}$$

$$r'_{e2} \cong \frac{25 \text{ mV}}{I_{E2}} = \frac{25 \text{ mV}}{0.446 \text{ mA}} = 56 \Omega$$

$$R_{in(2)} = \beta_{ac} r'_{e2} = (125)(56 \Omega) = 7 \text{ k}\Omega$$

$$r'_{e1} \cong \frac{25 \text{ mV}}{I_{E1}} = \frac{25 \text{ mV}}{0.311 \text{ mA}} = 80.4 \Omega$$

$$A_{v1} = \frac{R_3 \parallel R_{in(2)}}{r'_{e1}} = \frac{22 \text{ k}\Omega \parallel 7 \text{ k}\Omega}{80.4 \text{ k}\Omega} = \mathbf{66}$$

$$A_{v2} = \frac{R_5}{r'_{e2}} = \frac{10 \text{ k}\Omega}{56 \Omega} = \mathbf{179}$$

$$A'_v = A_{v1}A_{v2} = (66)(179) = \mathbf{11,814}$$

32. (a)  $20 \log(12) = \mathbf{21.6 \text{ dB}}$   
 (b)  $20 \log(50) = \mathbf{34.0 \text{ dB}}$   
 (c)  $20 \log(100) = \mathbf{40.0 \text{ dB}}$   
 (d)  $20 \log(2500) = \mathbf{68.0 \text{ dB}}$

33. (a)  $20 \log\left(\frac{V_2}{V_1}\right) = 3 \text{ dB}$       (b)  $20 \log\left(\frac{V_2}{V_1}\right) = 6 \text{ dB}$       (c)  $20 \log\left(\frac{V_2}{V_1}\right) = 10 \text{ dB}$

$$\log\left(\frac{V_2}{V_1}\right) = \frac{3}{20} = 0.15 \quad \log\left(\frac{V_2}{V_1}\right) = \frac{6}{20} = 0.3 \quad \log\left(\frac{V_2}{V_1}\right) = \frac{10}{20} = 0.5$$

$$\frac{V_2}{V_1} = \mathbf{1.41} \quad \frac{V_2}{V_1} = \mathbf{2} \quad \frac{V_2}{V_1} = \mathbf{3.16}$$

(d)  $20 \log\left(\frac{V_2}{V_1}\right) = 20 \text{ dB}$       (b)  $20 \log\left(\frac{V_2}{V_1}\right) = 40 \text{ dB}$

$$\log\left(\frac{V_2}{V_1}\right) = \frac{20}{20} = 1 \quad \log\left(\frac{V_2}{V_1}\right) = \frac{40}{20} = 2$$

$$\frac{V_2}{V_1} = \mathbf{10} \quad \frac{V_2}{V_1} = \mathbf{100}$$

## Chapter 6

### Section 6-7 Troubleshooting

$$34. \quad V_E = \left( \frac{R_1}{R_1 + R_2} \right) 10 \text{ V} - 0.7 \text{ V} = \left( \frac{10 \text{ k}\Omega}{57 \text{ k}\Omega} \right) 10 \text{ V} - 0.7 \text{ V} = 1.05 \text{ V}$$

$$I_E = \frac{V_E}{R_4} = \frac{1.05 \text{ V}}{1.0 \text{ k}\Omega} = 1.05 \text{ mA}$$

$$V_C = 10 \text{ V} - (1.05 \text{ mA})(4.7 \text{ k}\Omega) = 5.07 \text{ V}$$

$$V_{CE} = 5.07 \text{ V} - 1.05 \text{ V} = 4.02 \text{ V}$$

$$r'_{CE} \cong \frac{V_{CE}}{I_E} = \frac{4.02 \text{ V}}{1.05 \text{ mA}} = 3.83 \text{ k}\Omega$$

With  $C_2$  shorted:

$$R_{IN(2)} = R_6 \parallel \beta_{DC} R_8 = 10 \text{ k}\Omega \parallel 125(1.0 \text{ k}\Omega) = 9.26 \text{ k}\Omega$$

Looking from the collector of  $Q_1$ :

$$(r'_{CE} + R_4) \parallel R_{IN(2)} = (3.83 \text{ k}\Omega + 1.0 \text{ k}\Omega) \parallel 9.26 \text{ k}\Omega = 3.17 \text{ k}\Omega$$

$$V_{C1} = \left( \frac{3.17 \text{ k}\Omega}{3.17 \text{ k}\Omega + 4.7 \text{ k}\Omega} \right) 10 \text{ V} = 4.03 \text{ V}$$

35.  $Q_1$  is in **cutoff**.  $I_C = 0 \text{ A}$ , so  $V_{C2} = 10 \text{ V}$ .

36. (a) Reduced gain  
 (b) No output signal  
 (c) Reduced gain  
 (d) Bias levels of first stage will change.  $I_C$  will increase and  $Q_1$  will go into saturation.  
 (e) No signal at the  $Q_1$  collector  
 (f) Signal at the  $Q_2$  base. No output signal.

37.  $r'_e = 10.9 \Omega$                        $R_m = 1.48 \text{ k}\Omega$   
 $A_{v1} = 93.6$                                $A_{v2} = 302$

Test Point	DC Volts	AC Volts (rms)
Input	0 V	25 $\mu\text{A}$
$Q_1$ base	2.99 V	20.8 $\mu\text{V}$
$Q_1$ emitter	2.29 V	0 V
$Q_1$ collector	7.44 V	1.95 mV
$Q_2$ base	2.99 V	1.95 mV
$Q_2$ emitter	2.29 V	0 V
$Q_2$ collector	7.44 V	589 mV
Output	0 V	589 mV



**System Application Problems**

38. For the block diagram of textbook Figure 6-40 with no output from the power amplifier or preamplifier and only one faulty block, the power amplifier must be ok because the fault must be one that affects the preamplifier's output prior to the power amplifier. Check the input to the preamplifier.

39. For the circuit of textbook Figure 6-53, the dc and ac operating parameters are

$$V_{B1} = \left( \frac{15 \text{ k}\Omega}{83 \text{ k}\Omega} \right) 9 \text{ V} = (0.181)9 \text{ V} = 1.63 \text{ V}$$

$$V_E = 1.63 \text{ V} - 0.7 \text{ V} = 0.93 \text{ V}$$

$$I_{E1} = 927 \text{ }\mu\text{A}$$

$$r'_e = \frac{25 \text{ mV}}{927 \text{ }\mu\text{A}} = 27 \text{ }\Omega$$

$$A_{v(1)} = \frac{2.2 \text{ k}\Omega}{27 \text{ }\Omega} = 81.5 \text{ unloaded}$$

$$V_{B2} = \left( \frac{22 \text{ k}\Omega \parallel (200)(1.22 \text{ k}\Omega)}{100 \text{ k}\Omega + 22 \text{ k}\Omega \parallel (200)(1.22 \text{ k}\Omega)} \right) 9 \text{ V} = 0.81 \text{ V}$$

$$I_{E2} = \frac{0.81 \text{ V}}{1.22 \text{ k}\Omega} = 665 \text{ }\mu\text{A}$$

$$r'_e = \frac{25 \text{ mV}}{665 \text{ }\mu\text{A}} = 37.6 \text{ }\Omega$$

$$A_{v(2)} = \frac{4.7 \text{ k}\Omega}{220 \text{ }\Omega + 37.6 \text{ }\Omega} = 18.2 \text{ unloaded}$$

$$Z_{in(2)} = 100 \text{ k}\Omega \parallel 22 \text{ k}\Omega \parallel (200)(288 \text{ }\Omega) = 13.7 \text{ k}\Omega$$

So, the loaded gain of  $Q_1$  is equal to

$$\frac{13.7 \text{ k}\Omega}{13.7 \text{ k}\Omega + 2.2 \text{ k}\Omega} = 0.862 \text{ of the unloaded gain}$$

(a) With  $C_2$  open, the input circuit is developed in Figure 6-3.

From this,

$$A_v = \frac{R_C}{R_4 \parallel (r'_e + (R_1 \parallel R_2) / \beta_{ac})}$$

$$= \frac{2.2 \text{ k}\Omega}{1.0 \text{ k}\Omega \parallel (27 \text{ }\Omega + (68 \text{ k}\Omega \parallel 15 \text{ k}\Omega) / 200)} = 27.1 \text{ unloaded}$$

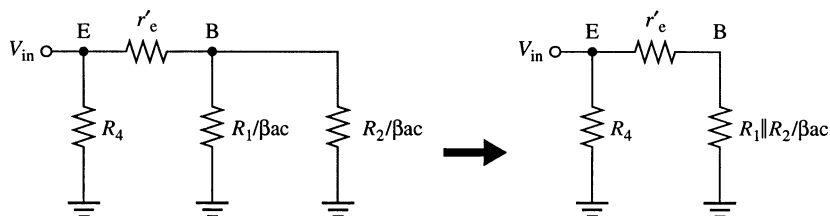

Figure 6-3

## Chapter 6

The loading factor is unchanged and stage 2 is unaffected so the overall ac gain is

$$A_v' = (0.862)(27.1)(18.2) = 425$$

$$V_{out(2)} = 2 \text{ mV}(425) = \mathbf{850 \text{ mV rms}}$$

$$V_{C(2)} = 9 \text{ V} - (4.7 \text{ k}\Omega)(665 \text{ }\mu\text{A}) = \mathbf{5.87 \text{ V dc}}$$

(b) If  $C_1$  is open, no input is applied so

$$V_{out(2)} = \mathbf{0 \text{ V}}$$

$$V_{C(2)} = \mathbf{5.87 \text{ V}}$$

(c) If  $C_3$  is open, no signal is coupled to  $Q_2$ .

$$V_{out(2)} = \mathbf{0 \text{ V}}$$

$$V_{C(2)} = \mathbf{5.87 \text{ V}}$$

(d) If  $C_4$  is open, the gain of stage 2 changes to

$$A_v = \frac{R_7}{r_{e(2)}' + R_8 + R_9} = \frac{4.7 \text{ k}\Omega}{37.6 \text{ }\Omega + 220 \text{ }\Omega + 1.0 \text{ k}\Omega} = 3.74$$

$$V_{out(2)} = (2 \text{ mV})(27.1)(3.74) = \mathbf{203 \text{ mV rms}}$$

$$V_{C(2)} = \mathbf{5.87 \text{ V}}$$

(e) If the  $Q_1$  collector is internally open, no signal reaches the base of  $Q_2$ .

$$V_{out} = \mathbf{0 \text{ V}}$$

$$V_{C(2)} = \mathbf{5.87 \text{ V}}$$

(f) If the  $Q_2$  emitter is shorted to ground, the transistor saturates.

$$V_{out} = \mathbf{0 \text{ V}}$$

$$V_{C(2)} = \mathbf{0 \text{ V}}$$

$$40. \quad V_{B2} = \left( \frac{220 \text{ k}\Omega \parallel (200)(1.22 \text{ k}\Omega)}{100 \text{ k}\Omega + 220 \text{ k}\Omega \parallel (200)(1.22 \text{ k}\Omega)} \right) 9 \text{ V} = 4.83 \text{ V}$$

$$V_E = 4.83 \text{ V} - 0.7 \text{ V} = 4.13 \text{ V}$$

$$I_E = \frac{4.13 \text{ V}}{1.22 \text{ k}\Omega} = 3.38 \text{ mA}$$

$$r_e' = \frac{25 \text{ mV}}{3.38 \text{ mA}} = 7.39 \text{ }\Omega$$

$$V_{C(2)} = 9 \text{ V} - (4.7 \text{ k}\Omega)(3.38 \text{ mA}) = -6.9 \text{ V}$$

The transistor is saturated, so  $V_{out} = \mathbf{0 \text{ V}}$ .

$$V_{C(2)} = \left( \frac{1.22 \text{ k}\Omega}{5.92 \text{ k}\Omega} \right) 9 \text{ V} = \mathbf{1.85 \text{ V}}$$

41. (a)  $Q_1$  is in **cutoff**.

$$(b) \quad V_{C1} = \mathbf{9 \text{ V}}$$

(c)  $V_{C2}$  is unchanged and at  $\mathbf{5.87 \text{ V}}$

**Data Sheet Problems**

42. From the data sheet in textbook Appendix C:  
 (a) for a 2N3947,  $\beta_{ac(\min)} = h_{fe(\min)} = 100$   
 (b) For a 2N3947,  $r'_{e(\min)}$  cannot be determined since  $h_{re(\min)}$  is not given.  
 (c) For a 2N3947,  $r'_{c(\min)}$  cannot be determined since  $h_{re(\min)}$  is not given.
43. From the 2N3947 data sheet in Appendix C:  
 (a) For a 2N3947,  $\beta_{ac(\max)} = 700$   
 (b) For a 2N3947,  $r'_{e(\max)} = \frac{h_{re}}{h_{oe}} = \frac{20 \times 10^{-4}}{50 \mu S} = 40 \Omega$   
 (c) For a 2N3947,  $r'_{c(\max)} = \frac{h_{re} + 1}{h_{oe}} = \frac{20 \times 10^{-4} + 1}{50 \mu S} = 20 \text{ k}\Omega$
44. For maximum current gain, a 2N3947 should be used.
45. In the circuit of textbook Figure 6-53, a leaky coupling capacitor would affect the biasing of the transistors, attenuate the ac signal, and decrease the frequency response.
46. See Figure 6-4.

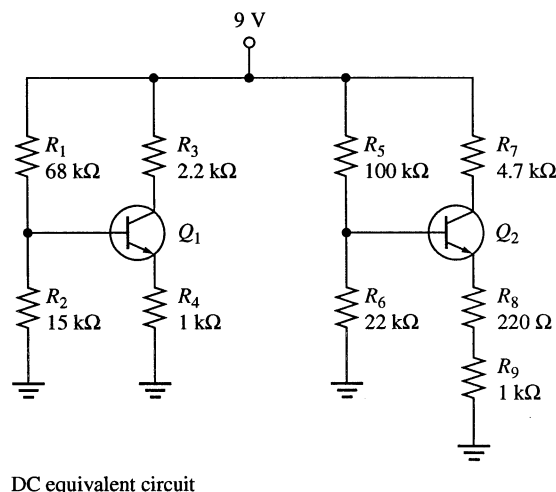
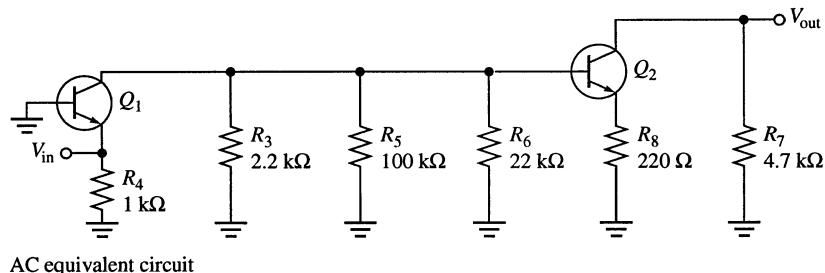

**Figure 6-4**

## Chapter 6

47. See Figure 6-5.

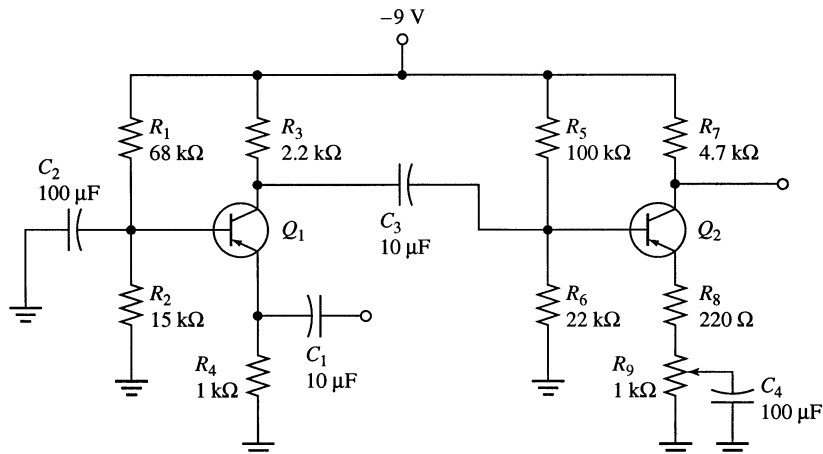

Figure 6-5

48.  $R_C > (100)(330 \Omega) = 33 \text{ k}\Omega$   
 To prevent cutoff,  $V_C$  must be no greater than  
 $12 \text{ V} - (100)(1.414)(25 \text{ mV}) = 8.46 \text{ V}$   
 In addition,  $V_C$  must fall no lower than  $8.46 \text{ V} - 3.54 \text{ V} = 4.93 \text{ V}$  to prevent saturation.  
 $R_C = 100(R_E + r'_e)$

$$r'_e = \frac{25 \text{ mV}}{I_E}$$

$$12 \text{ V} - I_C R_C = 8.46 \text{ V}$$

$$I_C R_C = 3.54 \text{ V}$$

$$I_C(100(R_E + r'_e)) = 3.54 \text{ V}$$

$$I_C \left( 100 \left( 330 \Omega + \frac{25 \text{ mV}}{I_C} \right) \right) \cong 3.54 \text{ V}$$

$$(33 \text{ k}\Omega)I_C + 2.5 \text{ V} = 3.54 \text{ V}$$

$$I_C = 31.4 \mu\text{A}$$

$$r'_e \cong \frac{25 \text{ mV}}{31.4 \mu\text{A}} = 797 \Omega$$

$$R_C = 100(330 \Omega + 797 \Omega) = 113 \text{ k}\Omega$$

$$\text{Let } R_C = 120 \text{ k}\Omega.$$

$$V_C = 12 \text{ V} - (31.4 \mu\text{A})(120 \text{ k}\Omega) = 8.23 \text{ V}$$

$$V_{C(\text{sat})} = 8.23 \text{ V} - 3.54 \text{ V} = 4.69 \text{ V}$$

$$\frac{R_{E(\text{tot})}}{R_C} = \frac{4.69 \text{ V}}{7.31 \text{ V}}$$

$$R_{E(\text{tot})} = (0.642)(120 \text{ k}\Omega) = 77 \text{ k}\Omega. \text{ Let } R_E = 68 \text{ k}\Omega.$$

$$V_E = (31.4 \mu\text{A})(68 \text{ k}\Omega) = 2.14 \text{ V}$$

$$V_B = 2.14 \text{ V} + 0.7 \text{ V} = 2.84 \text{ V}$$

$$\frac{R_2}{R_1} = \frac{2.84 \text{ V}}{9.16 \text{ V}} = 0.310$$

$$R_2 = 0.310R_1. \text{ If } R_1 = 20 \text{ k}\Omega, R_2 = 6.2 \text{ k}\Omega.$$

The amplifier circuit is shown in Figure 6-6.

The amplifier circuit is shown in Figure 6-6.

From the design:

$$V_B = \left( \frac{6.2 \text{ k}\Omega}{26.2 \text{ k}\Omega} \right) 12 \text{ V} = 2.84 \text{ V}$$

$$V_E = 2.14 \text{ V}$$

$$I_C \cong I_E = \frac{2.14 \text{ V}}{68.3 \text{ k}\Omega} = 31.3 \text{ }\mu\text{A}$$

$$r'_e = \frac{25 \text{ mV}}{31.3 \text{ }\mu\text{A}} = 798 \text{ }\Omega$$

$$A_v = \frac{120 \text{ k}\Omega}{795 \text{ }\Omega + 330 \text{ }\Omega} = 106 \text{ or } 40.5 \text{ dB}$$

$$V_C = 12 \text{ V} - (31.3 \text{ }\mu\text{A})(120 \text{ k}\Omega) = 8.24 \text{ V}$$

The design is a close fit.

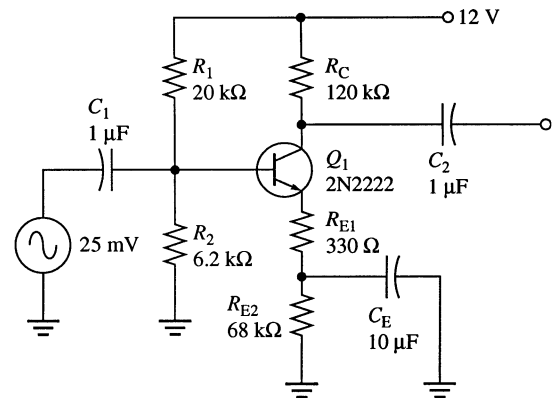

**Figure 6-6**

49. See Figure 6-7.

$$R_{in} = 120 \text{ k}\Omega \parallel 120 \text{ k}\Omega \parallel (100)(5.1 \text{ k}\Omega) = 53.6 \text{ k}\Omega \text{ minimum}$$

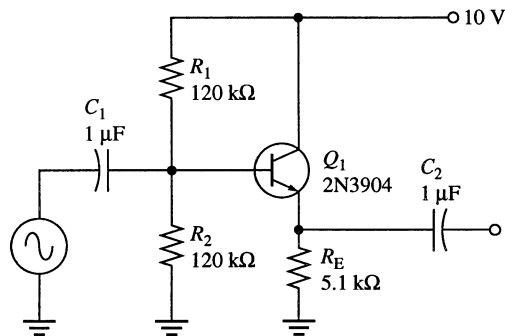

**Figure 6-7**

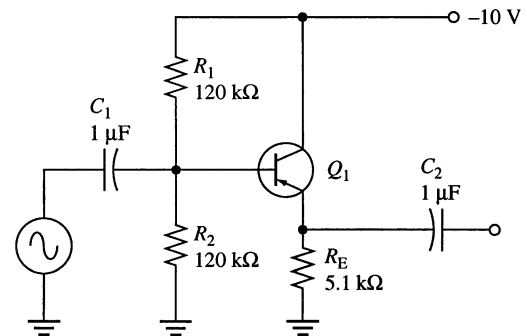

**Figure 6-8**

50. See Figure 6-8.

51. See Figure 6-9.

$$I_C = \frac{6 \text{ V} - 0.7 \text{ V}}{510 \text{ }\Omega + 2 \text{ k}\Omega/100} = 10 \text{ mA}$$

$$r'_e = \frac{25 \text{ mV}}{10 \text{ mA}} = 2.5 \text{ }\Omega$$

$$A_v = \frac{180 \text{ }\Omega}{2.5 \text{ }\Omega} = 72.4$$

This is reasonably close ( $\approx 3.3\%$  off) and can be made closer by putting a  $7.5 \text{ }\Omega$  resistor in series with the  $180 \text{ }\Omega$  collector resistor.

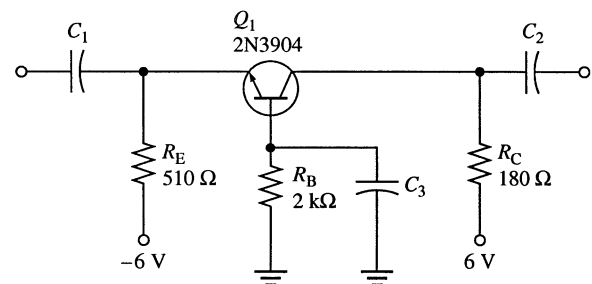

**Figure 6-9**

## Chapter 6

---

52. The cutoff frequency of  $C_3$  is

$$\frac{1}{2\pi(10 \mu\text{F})(22 \text{ k}\Omega + (100 \text{ k}\Omega \parallel 22 \text{ k}\Omega \parallel (200)(220 \Omega + 33 \Omega))} = 0.45 \text{ Hz}$$

- The cutoff frequency of  $C_2$  is

$$\frac{1}{2\pi(10 \mu\text{F})(1.0 \text{ k}\Omega \parallel 27 \Omega)} = 606 \text{ Hz}$$

- $C_2$  must be increased to

$$\frac{1}{2\pi(10 \text{ Hz})(1.0 \text{ k}\Omega \parallel 27 \Omega)} = 606 \mu\text{F} \text{ (nearest standard value is } 680 \mu\text{F)}$$

53.  $I_C \cong I_E$

$$A_v = \frac{R_C}{r'_e} \cong \frac{R_C}{25 \text{ mV}/I_E} \cong \frac{R_C}{25 \text{ mV}/I_C} = \frac{R_C I_C}{25 \text{ mV}} = \frac{V_{R_C}}{25 \text{ mV}} = 40V_{R_C}$$

### EWB/Multisim Troubleshooting Problems

The solutions showing instrument connections for Problems 54 through 59 are available in the Solutions folder for Chapter 6 on the CD-ROM provided with the textbook. The solutions may be accessed using the password *ED5FLOYD*. The faults in the circuit files may be accessed using the password *book* (all lowercase).

54.  $C_2$  open
55.  $C_2$  shorted
56.  $R_E$  leaky
57.  $C_1$  open
58.  $C_2$  open
59.  $C_3$  open

# Chapter 7

## Field-Effect Transistors (FETs)

---

### Section 7-1 The JFET

- A greater  $V_{GS}$  **narrows** the depletion region.
  - The channel resistance **increases** with increased  $V_{GS}$ .
- The gate-to-source voltage of an  $n$ -channel JFET must be zero or negative in order to maintain the required reverse-bias condition.
- See Figure 7-1.

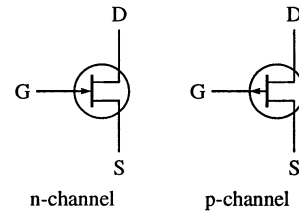

Figure 7-1

- See Figure 7-2.

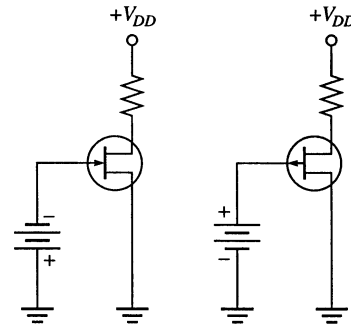

Figure 7-2

### Section 7-2 JFET Characteristics and Parameters

- $V_{DS} = V_P = 5 \text{ V}$  at point where  $I_D$  becomes constant.
- $V_{GS(\text{off})} = -V_P = -6 \text{ V}$   
The device is **on**, because  $V_{GS} = -2 \text{ V}$ .
- By definition,  $I_D = I_{DSS}$  when  $V_{GS} = 0 \text{ V}$  for values of  $V_{DS} > V_P$ .  
Therefore,  $I_D = 10 \text{ mA}$ .
- Since  $V_{GS} > V_{GS(\text{off})}$ , the JFET is off and  $I_D = 0 \text{ A}$ .

## Chapter 7

9.  $V_P = -V_{GS(off)} = -(-4 \text{ V}) = 4 \text{ V}$   
 The voltmeter reads  $V_{DS}$ . As  $V_{DD}$  is increased,  $V_{DS}$  also increases. The point at which  $I_D$  reaches a constant value is  $V_{DS} = V_P = 4 \text{ V}$ .

10. 
$$I_D = I_{DSS} \left( 1 - \frac{V_{GS}}{V_{GS(off)}} \right)^2$$

$$I_D = 5 \text{ mA} \left( 1 - \frac{0 \text{ V}}{-8 \text{ V}} \right)^2 = 5 \text{ mA}$$

$$I_D = 5 \text{ mA} \left( 1 - \frac{-1 \text{ V}}{-8 \text{ V}} \right)^2 = 3.83 \text{ mA}$$

$$I_D = 5 \text{ mA} \left( 1 - \frac{-2 \text{ V}}{-8 \text{ V}} \right)^2 = 2.81 \text{ mA}$$

$$I_D = 5 \text{ mA} \left( 1 - \frac{-3 \text{ V}}{-8 \text{ V}} \right)^2 = 1.95 \text{ mA}$$

$$I_D = 5 \text{ mA} \left( 1 - \frac{-4 \text{ V}}{-8 \text{ V}} \right)^2 = 1.25 \text{ mA}$$

$$I_D = 5 \text{ mA} \left( 1 - \frac{-5 \text{ V}}{-8 \text{ V}} \right)^2 = 0.703 \text{ mA}$$

$$I_D = 5 \text{ mA} \left( 1 - \frac{-6 \text{ V}}{-8 \text{ V}} \right)^2 = 0.313 \text{ mA}$$

$$I_D = 5 \text{ mA} \left( 1 - \frac{-7 \text{ V}}{-8 \text{ V}} \right)^2 = 0.078 \text{ mA}$$

$$I_D = 5 \text{ mA} \left( 1 - \frac{-8 \text{ V}}{-8 \text{ V}} \right)^2 = 0 \text{ mA}$$

See Figure 7-3.

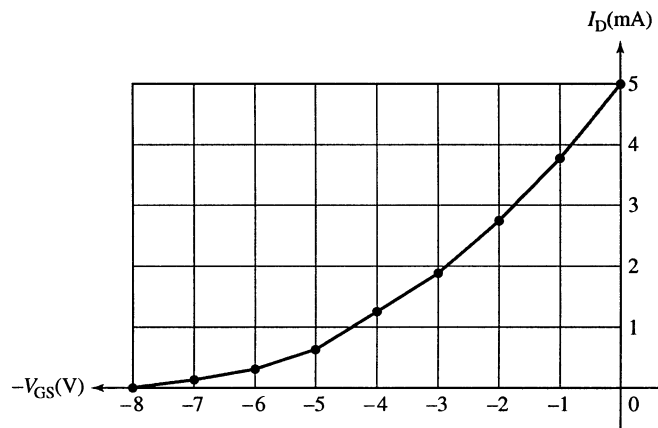

Figure 7-3



$$11. \quad I_D = I_{DSS} \left( 1 - \frac{V_{GS}}{V_{GS(off)}} \right)^2$$

$$1 - \frac{V_{GS}}{V_{GS(off)}} = \sqrt{\frac{I_D}{I_{DSS}}}$$

$$\frac{V_{GS}}{V_{GS(off)}} = 1 - \sqrt{\frac{I_D}{I_{DSS}}}$$

$$V_{GS} = V_{GS(off)} \left( 1 - \sqrt{\frac{I_D}{I_{DSS}}} \right)$$

$$V_{GS} = -8 \text{ V} \left( 1 - \sqrt{\frac{2.25 \text{ mA}}{5 \text{ mA}}} \right) = -8 \text{ V}(0.329) = -2.63 \text{ V}$$

$$12. \quad g_m = g_{m0} \left( 1 - \frac{V_{GS}}{V_{GS(off)}} \right) = 3200 \mu\text{S} \left( 1 - \frac{-4 \text{ V}}{-8 \text{ V}} \right) = 1600 \mu\text{S}$$

$$13. \quad g_m = g_{m0} \left( 1 - \frac{V_{GS}}{V_{GS(off)}} \right) = 2000 \mu\text{S} \left( 1 - \frac{-2 \text{ V}}{-7 \text{ V}} \right) = 1429 \mu\text{S}$$

$$y_{fs} = g_m = 1429 \mu\text{S}$$

$$14. \quad R_{IN} = \frac{V_{GS}}{I_{GSS}} = \frac{10 \text{ V}}{5 \text{ nA}} = 2000 \text{ M}\Omega$$

$$15. \quad V_{GS} = 0 \text{ V}: I_D = I_{DSS} \left( 1 - \frac{V_{GS}}{V_{GS(off)}} \right)^2 = 8 \text{ mA}(1 - 0)^2 = 8 \text{ mA}$$

$$V_{GS} = -1 \text{ V}: I_D = 8 \text{ mA} \left( 1 - \frac{-1 \text{ V}}{-5 \text{ V}} \right)^2 = 8 \text{ mA}(1 - 0.2)^2 = 8 \text{ mA}(0.8)^2 = 5.12 \text{ mA}$$

$$V_{GS} = -2 \text{ V}: I_D = 8 \text{ mA} \left( 1 - \frac{-2 \text{ V}}{-5 \text{ V}} \right)^2 = 8 \text{ mA}(1 - 0.4)^2 = 8 \text{ mA}(0.6)^2 = 2.88 \text{ mA}$$

$$V_{GS} = -3 \text{ V}: I_D = 8 \text{ mA} \left( 1 - \frac{-3 \text{ V}}{-5 \text{ V}} \right)^2 = 8 \text{ mA}(1 - 0.6)^2 = 8 \text{ mA}(0.4)^2 = 1.28 \text{ mA}$$

$$V_{GS} = -4 \text{ V}: I_D = 8 \text{ mA} \left( 1 - \frac{-4 \text{ V}}{-5 \text{ V}} \right)^2 = 8 \text{ mA}(1 - 0.8)^2 = 8 \text{ mA}(0.2)^2 = 0.320 \text{ mA}$$

$$V_{GS} = -5 \text{ V}: I_D = 8 \text{ mA} \left( 1 - \frac{-5 \text{ V}}{-5 \text{ V}} \right)^2 = 8 \text{ mA}(1 - 1)^2 = 8 \text{ mA}(0)^2 = 0 \text{ mA}$$

### Section 7-3 JFET Biasing

$$16. \quad V_{GS} = -I_D R_S = -(12 \text{ mA})(100 \Omega) = -1.2 \text{ V}$$

## Chapter 7

$$17. \quad R_S = \left| \frac{V_{GS}}{I_D} \right| = \left| \frac{-4 \text{ V}}{5 \text{ mA}} \right| = 800 \, \Omega$$

$$18. \quad R_S = \left| \frac{V_{GS}}{I_D} \right| = \left| \frac{-3 \text{ V}}{2.5 \text{ mA}} \right| = 1.2 \text{ k}\Omega$$

19. (a)  $I_D = I_{DSS} = 20 \text{ mA}$   
 (b)  $I_D = 0 \text{ A}$   
 (c)  $I_D$  increases

20. (a)  $V_S = (1 \text{ mA})(1.0 \text{ k}\Omega) = 1 \text{ V}$   
 $V_D = 12 \text{ V} - (1 \text{ mA})(4.7 \text{ k}\Omega) = 7.3 \text{ V}$   
 $V_G = 0 \text{ V}$   
 $V_{GS} = V_G - V_S = 0 \text{ V} - 1 \text{ V} = -1 \text{ V}$   
 $V_{DS} = 7.3 \text{ V} - 1 \text{ V} = 6.3 \text{ V}$

(b)  $V_S = (5 \text{ mA})(100 \, \Omega) = 0.5 \text{ V}$   
 $V_D = 9 \text{ V} - (5 \text{ mA})(470 \, \Omega) = 6.65 \text{ V}$   
 $V_G = 0 \text{ V}$   
 $V_{GS} = V_G - V_S = 0 \text{ V} - 0.5 \text{ V} = -0.5 \text{ V}$   
 $V_{DS} = 6.65 \text{ V} - 0.5 \text{ V} = 6.15 \text{ V}$

(c)  $V_S = (-3 \text{ mA})(470 \, \Omega) = -1.41 \text{ V}$   
 $V_D = -15 \text{ V} - (3 \text{ mA})(2.2 \text{ k}\Omega) = -8.4 \text{ V}$   
 $V_G = 0 \text{ V}$   
 $V_{GS} = V_G - V_S = 0 \text{ V} - (-1.41 \text{ V}) = 1.41 \text{ V}$   
 $V_{DS} = -8.4 \text{ V} - (-1.41 \text{ V}) = -6.99 \text{ V}$

21. From the graph,  $V_{GS} \cong -2 \text{ V}$  at  $I_D = 9.5 \text{ mA}$ .

$$R_S = \left| \frac{V_{GS}}{I_D} \right| = \left| \frac{-2 \text{ V}}{9.5 \text{ mA}} \right| = 211 \, \Omega$$

$$22. \quad I_D = \frac{I_{DSS}}{2} = \frac{14 \text{ mA}}{2} = 7 \text{ mA}$$

$$V_{GS} = \frac{V_{GS(\text{off})}}{3.414} = \frac{-10 \text{ V}}{3.414} = -2.93 \text{ V}$$

Since  $V_G = 0 \text{ V}$ ,  $V_S = V_G$ .

$$R_S = \left| \frac{V_{GS}}{I_D} \right| = \frac{2.93 \text{ V}}{7 \text{ mA}} = 419 \, \Omega \text{ (The nearest standard value is } 430 \, \Omega\text{.)}$$

$$R_D = \frac{V_{DD} - V_D}{I_D} = \frac{24 \text{ V} - 12 \text{ V}}{7 \text{ mA}} = 1.7 \text{ k}\Omega \text{ (The nearest standard value is } 1.8 \text{ k}\Omega\text{.)}$$

Select  $R_G = 1.0 \text{ M}\Omega$ . See Figure 7-4.

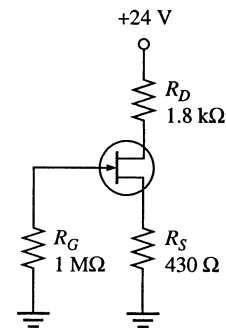

Figure 7-4

23.  $R_{IN(\text{total})} = R_G \parallel R_{IN}$   
 $R_{IN} = \left| \frac{V_{GS}}{I_{GSS}} \right| = \left| \frac{-10 \text{ V}}{20 \text{ nA}} \right| = 500 \text{ M}\Omega$   
 $R_{IN(\text{total})} = 10 \text{ M}\Omega \parallel 500 \text{ M}\Omega = \mathbf{9.8 \text{ M}\Omega}$
24. For  $I_D = 0$   
 $V_{GS} = -I_D R_S = (0)(330 \Omega) = 0 \text{ V}$   
 For  $I_D = I_{DSS} = 5 \text{ mA}$   
 $V_{GS} = -I_D R_S = -(5 \text{ mA})(330 \Omega) = -1.65 \text{ V}$   
 From the graph in Figure 7-61 in the textbook, the  $Q$ -point is  
 $V_{GS} \cong \mathbf{-0.95 \text{ V}}$  and  $I_D \cong \mathbf{2.9 \text{ mA}}$
25. For  $I_D = 0$ ,  
 $V_{GS} = 0 \text{ V}$   
 For  $I_D = I_{DSS} = 10 \text{ mA}$ ,  
 $V_{GS} = -I_D R_S = (10 \text{ mA})(390 \Omega) = 3.9 \text{ V}$   
 From the graph in Figure 7-62 in the textbook, the  $Q$ -point is  
 $V_{GS} \cong \mathbf{2.1 \text{ V}}$  and  $I_D \cong \mathbf{5.3 \text{ mA}}$
26. Since  $V_{R_D} = 9 \text{ V} - 5 \text{ V} = 4 \text{ V}$   
 $I_D = \frac{V_{R_D}}{R_D} = \frac{4 \text{ V}}{4.7 \text{ k}\Omega} = 0.85 \text{ mA}$   
 $V_S = I_D R_S = (0.85 \text{ mA})(3.3 \text{ k}\Omega) = 2.81 \text{ V}$   
 $V_G = \left( \frac{R_2}{R_1 + R_2} \right) V_{DD} = \left( \frac{2.2 \text{ M}\Omega}{12.2 \text{ M}\Omega} \right) 9 \text{ V} = 1.62 \text{ V}$   
 $V_{GS} = V_G - V_S = 1.62 \text{ V} - 2.81 \text{ V} = -1.19 \text{ V}$   
 $Q$ -point:  $I_D = \mathbf{0.85 \text{ mA}}$ ,  $V_{GS} = \mathbf{-1.19 \text{ V}}$
27. For  $I_D = 0$   
 $V_{GS} = V_G = \left( \frac{R_2}{R_1 + R_2} \right) V_{DD} = \left( \frac{2.2 \text{ M}\Omega}{5.5 \text{ M}\Omega} \right) 12 \text{ V} = 4.8 \text{ V}$   
 For  $V_{GS} = 0 \text{ V}$ ,  $V_S = 4.8 \text{ V}$   
 $I_D = \frac{V_S}{R_S} = \frac{|V_G - V_{GS}|}{R_S} = \frac{4.8 \text{ V}}{3.3 \text{ k}\Omega} = 1.45 \text{ mA}$   
 The  $Q$ -point is taken from the graph in Figure 7-64 in the textbook.  
 $I_D \cong \mathbf{1.9 \text{ mA}}$ ,  $V_{GS} = \mathbf{-1.5 \text{ V}}$

## Section 7-4 The MOSFET

28. See Figure 7-5.



**Figure 7-5**

## Chapter 7

29. An  $n$ -channel D-MOSFET with a positive  $V_{GS}$  is operating in the **enhancement mode**.
30. An E-MOSFET has no physical channel or depletion mode. A D-MOSFET has a physical channel and can be operated in either depletion or enhancement modes.
31. MOSFETs have a very high input resistance because the gate is insulated from the channel by an  $\text{SiO}_2$  layer.

### Section 7-5 MOSFET Characteristics and Parameters

32. (a)  $n$  channel

$$\begin{aligned}
 \text{(b)} \quad I_D &= I_{DSS} \left( 1 - \frac{V_{GS}}{V_{GS(\text{off})}} \right)^2 & I_D &= 8 \text{ mA} \left( 1 - \frac{-5 \text{ V}}{-5 \text{ V}} \right)^2 = \mathbf{0 \text{ mA}} \\
 I_D &= 8 \text{ mA} \left( 1 - \frac{-4 \text{ V}}{-5 \text{ V}} \right)^2 = \mathbf{0.32 \text{ mA}} & I_D &= 8 \text{ mA} \left( 1 - \frac{-3 \text{ V}}{-5 \text{ V}} \right)^2 = \mathbf{1.28 \text{ mA}} \\
 I_D &= 8 \text{ mA} \left( 1 - \frac{-2 \text{ V}}{-5 \text{ V}} \right)^2 = \mathbf{2.88 \text{ mA}} & I_D &= 8 \text{ mA} \left( 1 - \frac{-1 \text{ V}}{-5 \text{ V}} \right)^2 = \mathbf{5.12 \text{ mA}} \\
 I_D &= 8 \text{ mA} \left( 1 - \frac{0 \text{ V}}{-5 \text{ V}} \right)^2 = \mathbf{8 \text{ mA}} & I_D &= 8 \text{ mA} \left( 1 - \frac{1 \text{ V}}{-5 \text{ V}} \right)^2 = \mathbf{11.5 \text{ mA}} \\
 I_D &= 8 \text{ mA} \left( 1 - \frac{2 \text{ V}}{-5 \text{ V}} \right)^2 = \mathbf{15.7 \text{ mA}} & I_D &= 8 \text{ mA} \left( 1 - \frac{3 \text{ V}}{-5 \text{ V}} \right)^2 = \mathbf{20.5 \text{ mA}} \\
 I_D &= 8 \text{ mA} \left( 1 - \frac{4 \text{ V}}{-5 \text{ V}} \right)^2 = \mathbf{25.9 \text{ mA}} & I_D &= 8 \text{ mA} \left( 1 - \frac{5 \text{ V}}{-5 \text{ V}} \right)^2 = \mathbf{32 \text{ mA}}
 \end{aligned}$$

- (c) See Figure 7-6.

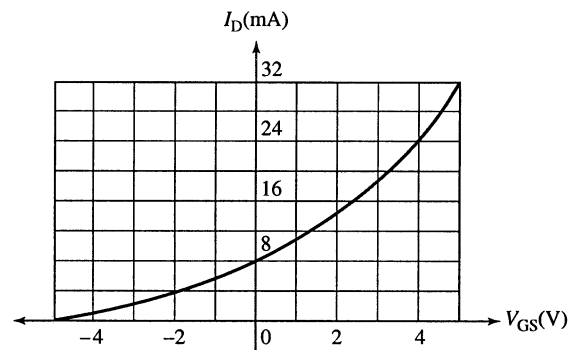

Figure 7-6

$$33. \quad I_D = I_{DSS} \left( 1 - \frac{V_{GS}}{V_{GS(off)}} \right)^2$$

$$I_{DSS} = \frac{I_D}{\left( 1 - \frac{V_{GS}}{V_{GS(off)}} \right)^2} = \frac{3 \text{ mA}}{\left( 1 - \frac{-2 \text{ V}}{-10 \text{ V}} \right)^2} = 4.69 \text{ mA}$$

$$34. \quad K = \frac{I_{D(on)}}{(V_{GS} - V_{GS(th)})^2} = \frac{10 \text{ mA}}{(-12 \text{ V} + 3 \text{ V})^2} = 0.12 \text{ mA/V}^2$$

$$I_D = K(V_{GS} - V_{GS(off)})^2 = (0.12 \text{ mA/V}^2)(-6 \text{ V} + 3 \text{ V})^2 = 1.08 \text{ mA}$$

### Section 7-6 MOSFET Biasing

35. (a) Depletion  
(b) Enhancement  
(c) Zero bias  
(d) Depletion

$$36. \quad (a) \quad V_{GS} = \left( \frac{10 \text{ M}\Omega}{14.7 \text{ M}\Omega} \right) 10 \text{ V} = 6.8 \text{ V} \quad \text{This MOSFET is on.}$$

$$(b) \quad V_{GS} = \left( \frac{1.0 \text{ M}\Omega}{11 \text{ M}\Omega} \right) (-25 \text{ V}) = -2.27 \text{ V} \quad \text{This MOSFET is off.}$$

37. Since  $V_{GS} = 0 \text{ V}$  for each circuit,  $I_D = I_{DSS} = 8 \text{ mA}$ .
- (a)  $V_{DS} = V_{DD} - I_D R_D = 12 \text{ V} - (8 \text{ mA})(1.0 \text{ k}\Omega) = 4 \text{ V}$   
 (b)  $V_{DS} = V_{DD} - I_D R_D = 15 \text{ V} - (8 \text{ mA})(1.2 \text{ k}\Omega) = 5.4 \text{ V}$   
 (c)  $V_{DS} = V_{DD} - I_D R_D = -9 \text{ V} - (-8 \text{ mA})(560 \Omega) = -4.52 \text{ V}$

38. (a)  $I_{D(on)} = 3 \text{ mA @ } 4 \text{ V}, V_{GS(th)} = 2 \text{ V}$

$$V_{GS} = \left( \frac{R_2}{R_1 + R_2} \right) V_{DD} = \left( \frac{4.7 \text{ M}\Omega}{14.7 \text{ M}\Omega} \right) 10 \text{ V} = 3.2 \text{ V}$$

$$K = \frac{I_{D(on)}}{(V_{GS} - V_{GS(th)})^2} = \frac{3 \text{ mA}}{(4 \text{ V} - 2 \text{ V})^2} = \frac{3 \text{ mA}}{(2 \text{ V})^2} = 0.75 \text{ mA/V}^2$$

$$I_D = K(V_{GS} - V_{GS(th)})^2 = (0.75 \text{ mA/V}^2)(3.2 \text{ V} - 2 \text{ V})^2 = 1.08 \text{ mA}$$

$$V_{DS} = V_{DD} - I_D R_D = 10 \text{ V} - (1.08 \text{ mA})(1.0 \text{ k}\Omega) = 10 \text{ V} - 1.08 \text{ V} = 8.92 \text{ V}$$

(b)  $I_{D(on)} = 2 \text{ mA @ } 4 \text{ V}, V_{GS(th)} = 1.5 \text{ V}$

$$V_{GS} = \left( \frac{R_2}{R_1 + R_2} \right) V_{DD} = \left( \frac{10 \text{ M}\Omega}{20 \text{ M}\Omega} \right) 5 \text{ V} = 2.5 \text{ V}$$

$$K = \frac{I_{D(on)}}{(V_{GS} - V_{GS(th)})^2} = \frac{2 \text{ mA}}{(3 \text{ V} - 1.5 \text{ V})^2} = \frac{2 \text{ mA}}{(1.5 \text{ V})^2} = 0.89 \text{ mA/V}^2$$

$$I_D = K(V_{GS} - V_{GS(th)})^2 = (0.89 \text{ mA/V}^2)(2.5 \text{ V} - 1.5 \text{ V})^2 = 0.89 \text{ mA}$$

$$V_{DS} = V_{DD} - I_D R_D = 5 \text{ V} - (0.89 \text{ mA})(1.5 \text{ k}\Omega) = 5 \text{ V} - 1.34 \text{ V} = 3.66 \text{ V}$$

## Chapter 7

---

39. (a)  $V_{DS} = V_{GS} = 5 \text{ V}$   
$$I_D = \frac{V_{DD} - V_{DS}}{R_D} = \frac{12 \text{ V} - 5 \text{ V}}{2.2 \text{ k}\Omega} = 3.18 \text{ mA}$$
- (b)  $V_{DS} = V_{GS} = 3.2 \text{ V}$   
$$I_D = \frac{V_{DD} - V_{DS}}{R_D} = \frac{8 \text{ V} - 3.2 \text{ V}}{4.7 \text{ k}\Omega} = 1.02 \text{ mA}$$
40.  $V_{DS} = V_{DD} - I_D R_D = 15 \text{ V} - (1 \text{ mA})(8.2 \text{ k}\Omega) = 6.8 \text{ V}$   
 $V_{GS} = V_{DS} - I_G R_G = 6.8 \text{ V} - (50 \text{ pA})(22 \text{ M}\Omega) = 6.799 \text{ V}$

### Section 7-7 Troubleshooting

41. When  $I_D$  goes to zero, the possible faults are:  
 $R_D$  or  $R_S$  open, JFET drain-to-source open, no supply voltage, or ground connection open.
42. If  $I_D$  goes to 16 mA, the possible faults are:  
The JFET is shorted from drain-to-source or  $V_{DD}$  has increased.
43. If  $V_{DD}$  is changed to  $-20 \text{ V}$ ,  $I_D$  will change very little or none because the device is operating in the constant-current region of the characteristic curve.
44. The device is off. The gate bias voltage must be less than  $V_{GS(th)}$ . The gate could be shorted or partially shorted to ground.
45. The device is saturated, so there is very little voltage from drain-to-source. This indicates that  $V_{GS}$  is too high. The  $1.0 \text{ M}\Omega$  bias resistor is probably **open**.

### System Application Problems

46. With the  $100 \mu\text{F}$  capacitor open, power supply noise or ripple *could* affect the sensor outputs, producing false readings and alarms.
47. From the graph in textbook Figure 7-53:  
For  $\text{pH} = 5$ ,  $V_{\text{OUT}} = 300 \text{ mV}$   
For  $\text{pH} = 9$ ,  $V_{\text{OUT}} = -400 \text{ mV}$
48. A possible problem is that the voltmeter has an input resistance of  $1 \text{ M}\Omega$  instead of  $10 \text{ M}\Omega$  and is loading the sensor output.
49.  $V_{\text{OUT}} \cong 15 \text{ V} - (2.9 \text{ mA})(1 \text{ k}\Omega) = 15 \text{ V} - 2.9 \text{ V} = 12.1 \text{ V}$

### Data Sheet Problems

50. The 2N5457 is an ***n*-channel JFET**.

51. From the data sheet in textbook Figure 7-14:  
 (a) For a 2N5457,  $V_{GS(off)} = -0.5 \text{ V}$  minimum  
 (b) For a 2N5457,  $V_{DS(max)} = 25 \text{ V}$   
 (c) For a 2N5458 @  $25^\circ\text{C}$ ,  $P_{D(max)} = 310 \text{ mW}$   
 (d) For a 2N5459,  $V_{GS(rev)} = -25 \text{ V}$  maximum
52.  $P_{D(max)} = 310 \text{ mW} - (2.82 \text{ mW}/^\circ\text{C})(65^\circ\text{C} - 25^\circ\text{C}) = 310 \text{ mW} - 113 \text{ mW} = 197 \text{ mW}$
53.  $g_{m0(min)} = y_{fs} = 2000 \mu\text{S}$
54. Typical  $I_D = I_{DSS} = 9 \text{ mA}$
55. From the data sheet in textbook Figure 7-41:  
 Minimum  $V_{GS(th)} = 1 \text{ V}$
56. For a 2N7008 with  $V_{GS} = 10 \text{ V}$ ,  $I_D = 500 \text{ mA}$
57. From the data sheet graph in textbook Figure 7-52:  
 At  $V_{GS} = +3 \text{ V}$ ,  $I_D \cong 13 \text{ mA}$   
 At  $V_{GS} = -2 \text{ V}$ ,  $I_D \cong 0.4 \text{ mA}$
58.  $y_{fs} = 1500 \mu\text{S}$  at  $f = 1 \text{ kHz}$  and at  $f = 1 \text{ MHz}$  for both the 2N3796 and 2N3797.  
 There is **no change** in  $y_{fs}$  over the frequency range.
59. For a 2N3796,  $V_{GS(off)} = -3.0 \text{ V}$  typical

### Advanced Problems

60. For the circuit of textbook Figure 7-71:

$$I_D = I_{DSS} \left( 1 - \frac{V_{GS}}{V_{GS(off)}} \right)^2 \text{ where } V_{GS} = I_D R_S$$

From the 2N5457 data sheet:

$$I_{DSS(min)} = 1.0 \text{ mA and } V_{GS(off)} = -0.5 \text{ V minimum}$$

$$I_D = 66.3 \mu\text{A}$$

$$V_{GS} = -(66.3 \mu\text{A})(5.6 \text{ k}\Omega) = -0.371 \text{ V}$$

$$V_{DS} = 12 \text{ V} - (66.3 \mu\text{A})(10 \text{ k}\Omega + 5.6 \text{ k}\Omega) = 11.0 \text{ V}$$

61. For the circuit of textbook Figure 7-72:

$$V_C = \left( \frac{3.3 \text{ k}\Omega}{13.3 \text{ k}\Omega} \right) 9 \text{ V} = (0.248)(9 \text{ V}) = 2.23 \text{ V}$$

From the equation,

$$I_D = I_{DSS} \left( \frac{V_{GS}}{1 - V_{GS(off)}} \right)^2 \text{ where } V_{GS} = V_G - I_D R_S$$

$I_D$  is maximum for  $I_{DSS(max)}$  and  $V_{GS(off)}$  max, so that

$$I_{DSS} = 16 \text{ mA and } V_{GS(off)} = -8.0 \text{ V}$$

$$I_D = 3.58 \text{ mA}$$

$$V_{GS} = 2.23 \text{ V} - (3.58 \text{ mA})(1.8 \text{ k}\Omega) = 2.23 \text{ V} - 6.45 \text{ V} = -4.21 \text{ V}$$

## Chapter 7

---

62. From the 2N5457 data sheet:

$$I_{DSS(\min)} = 1.0 \text{ mA and } V_{GS(\text{off})} = -0.5 \text{ minimum}$$

$$I_{D(\min)} = \mathbf{66.3 \mu A}$$

$$V_{DS(\max)} = 12 \text{ V} - (66.3 \mu A)(15.6 \text{ k}\Omega) = \mathbf{11.0 \text{ V}}$$

and

$$I_{DSS(\max)} = 5.0 \text{ mA and } V_{GS(\text{off})} = -6.0 \text{ maximum}$$

$$I_{D(\max)} = \mathbf{677 \mu A}$$

$$V_{DS(\min)} = 12 \text{ V} - (677 \mu A)(15.6 \text{ k}\Omega) = \mathbf{1.4 \text{ V}}$$

63.  $V_{pH} = +300 \text{ mV}$

$$I_D = (2.9 \text{ mA})(1 + 0.3 \text{ V}/5.0 \text{ V})^2 = (2.9 \text{ mA})(1.06)^2 = 3.26 \text{ mA}$$

$$V_{DS} = 15 \text{ V} - (3.26 \text{ mA})(2.76 \text{ k}\Omega) = 15 \text{ V} - 8.99 \text{ V} = \mathbf{+6.01 \text{ V}}$$

64.  $1 \text{ mA} = I_{DSS} \left( 1 - \frac{(1 \text{ mA})R_S}{V_{GS(\text{off})}} \right)^2$

$$1 \text{ mA} = 2.9 \text{ mA} \left( 1 - \frac{(1 \text{ mA})R_S}{-0.5 \text{ V}} \right)^2$$

$$0.345 = \left( 1 - \frac{(1 \text{ mA})R_S}{-0.5 \text{ V}} \right)^2$$

$$0.587 = 1 - \frac{(1 \text{ mA})R_S}{-0.5 \text{ V}}$$

$$0.413 = \frac{(1 \text{ mA})R_S}{-0.5 \text{ V}}$$

$$R_S = 2.06 \text{ k}\Omega$$

Use  $R_S = \mathbf{2.2 \text{ k}\Omega}$ .

Then  $I_D = 963 \mu A$

$$V_{GS} = V_S = (963 \mu A)(2.2 \text{ k}\Omega) = 2.19 \text{ V}$$

$$\text{So, } V_D = 2.19 \text{ V} + 4.5 \text{ V} = 6.62 \text{ V}$$

$$R_D = \frac{9 \text{ V} - 6.62 \text{ V}}{963 \mu A} = 2.47 \text{ k}\Omega$$

Use  $R_D = \mathbf{2.4 \text{ k}\Omega}$ .

$$\text{So, } V_{DS} = 9 \text{ V} - (963 \mu A)(4.6 \text{ k}\Omega) = 4.57 \text{ V}$$



65. Let  $I_D = 20 \text{ mA}$ .

$$R_D = \frac{4 \text{ V}}{20 \text{ mA}} = 200 \Omega$$

Let  $V_S = 2 \text{ V}$ .

$$R_S = \frac{2 \text{ V}}{20 \text{ mA}} = 100 \Omega$$

For the 2N7008:

$$K = \frac{I_{D(\text{on})}}{(V_{GS(\text{on})} - V_{GS(\text{th})})^2} = \frac{500 \text{ mA}}{(10 \text{ V} - 1 \text{ V})^2} = 6.17 \text{ mA/V}^2$$

Let  $I_D = 20 \text{ mA}$ .

$$(V_{GS} - 1 \text{ V})^2 = \frac{20 \text{ V}}{6.17 \text{ mA/V}^2} = 3.24$$

$$V_{GS} - 1 \text{ V} = 1.8 \text{ V}$$

$$V_{GS} = 2.8 \text{ V}$$

$$V_G = V_S + 2.8 \text{ V} = 4.8 \text{ V}$$

For the voltage divider:

$$\frac{R_1}{R_2} = \frac{7.2 \text{ V}}{4.8 \text{ V}} = 1.5$$

Let  $R_2 = 10 \text{ k}\Omega$ .

$$R_1 = (1.5)(10 \text{ k}\Omega) = 15 \text{ k}\Omega$$

### EWB/Multisim Troubleshooting Problems

The solutions showing instrument connections for Problems 66 through 74 are available in the Solutions folder for Chapter 7 on the CD-ROM provided with the textbook. The solutions may be accessed using the password *ED5FLOYD*. The faults in the circuit files may be accessed using the password *book* (all lowercase).

66.  $R_S$  shorted

67.  $R_D$  shorted

68.  $R_G$  shorted

69.  $R_1$  open

70. Drain-source open

71.  $R_D$  open

72.  $R_2$  shorted

73. Drain-source shorted

74.  $R_1$  shorted

# Chapter 8

## FET Amplifiers

---

### Section 8-1 FET Amplification

1. (a)  $I_D = g_m V_{gs} = (6000 \mu\text{S})(10 \text{ mV}) = 60 \mu\text{A}$   
 (b)  $I_D = g_m V_{gs} = (6000 \mu\text{S})(150 \text{ mV}) = 900 \mu\text{A}$   
 (c)  $I_D = g_m V_{gs} = (6000 \mu\text{S})(0.6 \text{ V}) = 3.6 \text{ mA}$   
 (d)  $I_D = g_m V_{gs} = (6000 \mu\text{S})(1 \text{ V}) = 6 \text{ mA}$
2.  $A_v = g_m R_d$   

$$R_d = \frac{A_v}{g_m} = \frac{20}{3500 \mu\text{S}} = 5.71 \text{ k}\Omega$$
3.  $A_v = \left( \frac{R_D r'_{ds}}{R_D + r'_{ds}} \right) g_m = \left( \frac{(4.7 \text{ k}\Omega)(12 \text{ k}\Omega)}{16.7 \text{ k}\Omega} \right) 4.2 \text{ mS} = 14.2$
4.  $R_d = R_D \parallel r'_{ds} = 4.7 \text{ k}\Omega \parallel 12 \text{ k}\Omega = 3.38 \text{ k}\Omega$   

$$A_v = \frac{g_m R_d}{1 + g_m R_s} = \frac{(4.2 \text{ mS})(3.38 \text{ k}\Omega)}{1 + (4.2 \text{ mS})(1.0 \text{ k}\Omega)} = 2.73$$

### Section 8-2 Common-Source Amplifiers

5. (a) *N*-channel D-MOSFET with zero-bias.  
 $V_{GS} = 0 \text{ V}$ .  
 (b) *P*-channel JFET with self-bias.  
 $V_{GS} = -I_D R_S = (-3 \text{ mA})(330 \Omega) = -0.99 \text{ V}$   
*N*-channel E-MOSFET with voltage-divider bias.  
 (c)  $V_{GS} = \left( \frac{R_2}{R_1 + R_2} \right) V_{DD} = \left( \frac{4.7 \text{ k}\Omega}{14.7 \text{ k}\Omega} \right) 12 \text{ V} = 3.84 \text{ V}$
6. (a)  $V_G = 0 \text{ V}$ ,  $V_S = 0 \text{ V}$   
 $V_D = V_{DD} - I_D R_D = 15 \text{ V} - (8 \text{ mA})(1.0 \text{ k}\Omega) = 7 \text{ V}$   
 (b)  $V_G = 0 \text{ V}$   
 $V_S = -I_D R_D = -(3 \text{ mA})(330 \Omega) = -0.99 \text{ V}$   
 $V_D = V_{DD} - I_D R_D = -10 \text{ V} - (-3 \text{ mA})(1.5 \text{ k}\Omega) = -5.5 \text{ V}$   
 (c)  $V_G = \left( \frac{R_2}{R_1 + R_2} \right) V_{DD} = \left( \frac{4.7 \text{ k}\Omega}{14.7 \text{ k}\Omega} \right) 12 \text{ V} = 3.84 \text{ V}$   
 $V_S = 0 \text{ V}$   
 $V_D = V_{DD} - I_D R_D = 12 \text{ V} - (6 \text{ mA})(1.0 \text{ k}\Omega) = 6 \text{ V}$

7. (a) *n*-channel D-MOSFET  
 (b) *n*-channel JFET  
 (c) *p*-channel E-MOSFET
8. From the curve in Figure 8-18(a) in the textbook:  
 $I_{d(pp)} \cong 3.9 \text{ mA} - 1.3 \text{ mA} = \mathbf{2.6 \text{ mA}}$
9. From the curve in Figure 8-18(b) in the textbook:  
 $I_{d(pp)} \cong 6 \text{ mA} - 2 \text{ mA} = \mathbf{4 \text{ mA}}$   
 From the curve in Figure 8-18(c) in the textbook:  
 $I_{d(pp)} \cong 4.5 \text{ mA} - 1.3 \text{ mA} = \mathbf{3.2 \text{ mA}}$
10.  $V_D = V_{DD} - I_D R_D = 12 \text{ V} - (2.83 \text{ mA})(1.5 \text{ k}\Omega) = \mathbf{7.76 \text{ V}}$   
 $V_S = I_D R_S = (2.83 \text{ mA})(1.0 \text{ k}\Omega) = \mathbf{2.83 \text{ V}}$   
 $V_{DS} = V_D - V_S = 7.76 \text{ V} - 2.83 \text{ V} = \mathbf{4.93 \text{ V}}$   
 $V_{GS} = V_G - V_S = 0 \text{ V} - 2.83 \text{ V} = \mathbf{-2.83 \text{ V}}$

11.  $A_v = g_m R_d = g_m (R_D \parallel R_L) = 5000 \mu\text{S} (1.5 \text{ k}\Omega \parallel 10 \text{ k}\Omega) = 6.52$   
 $V_{pp(out)} = (2.828)(50 \text{ mV})(6.52) = \mathbf{920 \text{ mV}}$

12.  $A_v = g_m R_d$   
 $R_d = 1.5 \text{ k}\Omega \parallel 1.5 \text{ k}\Omega = 750 \Omega$   
 $A_v = (5000 \mu\text{S})(750 \Omega) = 3.75$   
 $V_{out} = A_v V_{in} = (3.75)(50 \text{ mV}) = \mathbf{188 \text{ mV rms}}$

13. (a)  $A_v = g_m R_d = g_m (R_D \parallel R_L) = 3.8 \text{ mS} (1.2 \text{ k}\Omega \parallel 22 \text{ k}\Omega) = 3.8 \text{ mS} (1138 \Omega) = \mathbf{4.32}$   
 (b)  $A_v = g_m R_d = g_m (R_D \parallel R_L) = 5.5 \text{ mS} (2.2 \text{ k}\Omega \parallel 10 \text{ k}\Omega) = 5.5 \text{ mS} (1.8 \text{ k}\Omega) = \mathbf{9.92}$

14. See Figure 8-1.

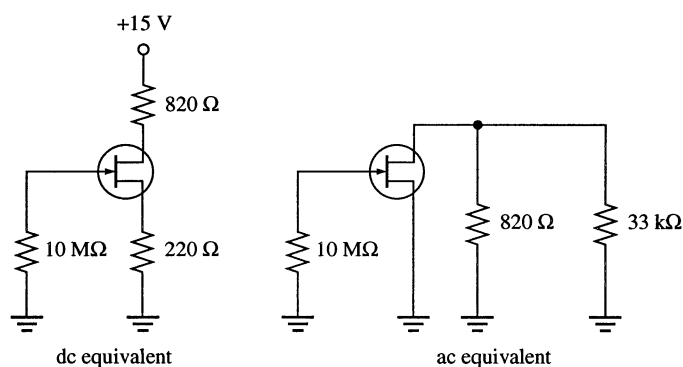

**Figure 8-1**

15.  $I_D = \frac{I_{DSS}}{2} = \frac{15 \text{ mA}}{2} = \mathbf{7.5 \text{ mA}}$

## Chapter 8

16.  $V_{GS} = (7.5 \text{ mA})(220 \Omega) = 1.65 \text{ V}$   
 $g_{m0} = \frac{2I_{DSS}}{|V_{GS(off)}|} = \frac{2(15 \text{ mA})}{4 \text{ V}} = 7.5 \text{ mS}$   
 $g_m = (7.5 \text{ mS})(1 - 1.65 \text{ V}/4 \text{ V}) = 4.41 \text{ mS}$   
 $A_v = \frac{g_m R_d}{1 + g_m R_S} = \frac{(4.41 \text{ mS})(820 \Omega \parallel 3.3 \text{ k}\Omega)}{1 + (4.41 \text{ mS})(220 \Omega)} = \frac{(4.41 \text{ mS})(657 \Omega)}{1 + 0.97} = 1.47$
17.  $A_v = g_m R_d = (4.41 \text{ mS})(820 \Omega \parallel 3.3 \text{ k}\Omega \parallel 4.7 \text{ k}\Omega) = (4.41 \text{ mS})(576 \Omega) = 2.54$
18.  $I_D = \frac{I_{DSS}}{2} = \frac{9 \text{ mA}}{2} = 4.5 \text{ mA}$   
 $V_{GS} = -I_D R_S = -(4.5 \text{ mA})(330 \Omega) = -1.49 \text{ V}$   
 $V_{DS} = V_{DD} - I_D(R_D + R_S) = 9 \text{ V} - (4.5 \text{ mA})(1.33 \text{ k}\Omega) = 3 \text{ V}$
19.  $A_v = g_m R_d = g_m (R_D \parallel R_L) = 3700 \mu\text{S}(1.0 \text{ k}\Omega \parallel 10 \text{ k}\Omega) = 3700 \mu\text{S}(909 \Omega) = 3.36$   
 $V_{out} = A_v V_{in} = (3.36)(10 \text{ mV}) = 33.6 \text{ mV rms}$
20.  $V_{GS} = \left( \frac{R_2}{R_1 + R_2} \right) V_{DD} = \left( \frac{6.8 \text{ k}\Omega}{24.8 \text{ k}\Omega} \right) 20 \text{ V} = 5.48 \text{ V}$   
 $K = \frac{I_{D(on)}}{(V_{GS} - V_{GS(th)})^2} = \frac{18 \text{ mA}}{(10 \text{ V} - 2.5 \text{ V})^2} = 0.32 \text{ mA/V}^2$   
 $I_D = K(V_{GS} - V_{GS(th)})^2 = 0.32 \text{ mA/V}^2(5.48 \text{ V} - 2.5 \text{ V})^2 = 2.84 \text{ mA}$   
 $V_{DS} = V_{DD} - I_D R_D = 20 \text{ V} - (2.84 \text{ mA})(1.0 \text{ k}\Omega) = 17.2 \text{ V}$
21.  $R_{IN} = \left| \frac{V_{GS}}{I_{GSS}} \right| = \left| \frac{-15 \text{ V}}{25 \text{ nA}} \right| = 600 \text{ M}\Omega$   
 $R_{in} = 10 \text{ M}\Omega \parallel 600 \text{ M}\Omega = 9.84 \text{ M}\Omega$
22.  $A_v = g_m R_d = 48 \text{ mS}(1.0 \text{ k}\Omega \parallel 10 \text{ M}\Omega) \cong 4.8$   
 $V_{out} = A_v V_{in} = 4.8(10 \text{ mV}) = 48 \text{ mV rms}$   
 $I_D = I_{DSS} = 15 \text{ mA}$   
 $V_D = 24 \text{ V} - (15 \text{ mA})(1.0 \text{ k}\Omega) = 9 \text{ V}$   
 See Figure 8-2.

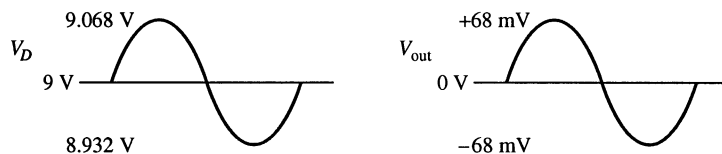

Figure 8-2

$$23. \quad V_{GS} = \left( \frac{R_2}{R_1 + R_2} \right) V_{DD} = \left( \frac{47 \text{ k}\Omega}{94 \text{ k}\Omega} \right) 18 \text{ V} = 9 \text{ V}$$

$$K = \frac{I_{D(\text{on})}}{(V_{GS} - V_{GS(\text{th})})^2} = \frac{8 \text{ mA}}{(12 \text{ V} - 4 \text{ V})^2} = 0.125 \text{ mA/V}^2$$

$$I_{D(\text{on})} = K(V_{GS} - V_{GS(\text{th})})^2 = 0.125 \text{ mA/V}^2 (9 \text{ V} - 4 \text{ V})^2 = 3.13 \text{ mA}$$

$$V_{DS} = V_{DD} - I_D R_D = 18 \text{ V} - (3.125 \text{ mA})(1.5 \text{ k}\Omega) = 13.3 \text{ V}$$

$$A_v = g_m R_D = 4500 \mu\text{S}(1.5 \text{ k}\Omega) = 6.75$$

$$V_{ds} = A_v V_{in} = 6.75(100 \text{ mV}) = 675 \text{ mV rms}$$

### Section 8-3 Common-Drain Amplifiers

$$24. \quad R_s = 1.2 \text{ k}\Omega \parallel 10 \text{ M}\Omega \cong 1.2 \text{ k}\Omega$$

$$A_v = \frac{g_m R_s}{1 + g_m R_s} = \frac{(5500 \mu\text{S})(1.2 \text{ k}\Omega)}{1 + (5500 \mu\text{S})(1.2 \text{ k}\Omega)} = 0.868$$

$$R_{IN} = \left| \frac{V_{GS}}{I_{GSS}} \right| = \left| \frac{-15 \text{ V}}{50 \text{ pA}} \right| = 3 \times 10^{11} \Omega$$

$$R_{in} = 10 \text{ M}\Omega \parallel 3 \times 10^{11} \Omega \cong 10 \text{ M}\Omega$$
  

$$25. \quad R_s = 1.2 \text{ k}\Omega \parallel 10 \text{ M}\Omega \cong 10 \text{ M}\Omega$$

$$A_v = \frac{g_m R_s}{1 + g_m R_s} = \frac{(3000 \mu\text{S})(10 \text{ M}\Omega)}{1 + (3000 \mu\text{S})(10 \text{ M}\Omega)} = 0.783$$

$$R_{IN} = \left| \frac{V_{GS}}{I_{GSS}} \right| = \left| \frac{-15 \text{ V}}{50 \text{ pA}} \right| = 3 \times 10^{11} \Omega$$

$$R_{in} = 10 \text{ M}\Omega \parallel 3 \times 10^{11} \Omega \cong 10 \text{ M}\Omega$$
  

$$26. \quad \text{(a) } R_s = 4.7 \text{ k}\Omega \parallel 47 \text{ k}\Omega = 4.27 \text{ k}\Omega$$

$$A_v = \frac{g_m R_s}{1 + g_m R_s} = \frac{(3000 \mu\text{S})(4.27 \text{ k}\Omega)}{1 + (3000 \mu\text{S})(4.27 \text{ k}\Omega)} = 0.928$$
  

$$\text{(b) } R_s = 1.0 \text{ k}\Omega \parallel 100 \Omega = 90.9 \Omega$$

$$A_v = \frac{g_m R_s}{1 + g_m R_s} = \frac{(4300 \mu\text{S})(90.9 \Omega)}{1 + (4300 \mu\text{S})(90.9 \Omega)} = 0.281$$
  

$$27. \quad \text{(a) } R_s = 4.7 \text{ k}\Omega \parallel 10 \text{ k}\Omega = 3.2 \text{ k}\Omega$$

$$A_v = \frac{g_m R_s}{1 + g_m R_s} = \frac{(3000 \mu\text{S})(3.2 \text{ k}\Omega)}{1 + (3000 \mu\text{S})(3.2 \text{ k}\Omega)} = 0.906$$
  

$$\text{(b) } R_s = 100 \Omega \parallel 10 \text{ k}\Omega = 99 \Omega$$

$$A_v = \frac{g_m R_s}{1 + g_m R_s} = \frac{(4300 \mu\text{S})(99 \Omega)}{1 + (4300 \mu\text{S})(99 \Omega)} = 0.299$$

## Chapter 8

---

### Section 8-4 Common-Gate Amplifiers

28.  $A_v = g_m R_d = 4000 \mu\text{S}(1.5 \text{ k}\Omega) = 6.0$

29.  $R_{in(\text{source})} = \frac{1}{g_m} = \frac{1}{4000 \mu\text{S}} = 250 \Omega$

30.  $A_v = g_m R_d = 3500 \mu\text{S}(10 \text{ k}\Omega) = 35$

$$R_{in} = R_S \parallel \left( \frac{1}{g_m} \right) = 2.2 \text{ k}\Omega \parallel \left( \frac{1}{3500 \mu\text{S}} \right) = 253 \Omega$$

### Section 8-5 Troubleshooting

31. (a)  $V_{D1} = V_{DD}$ ; No signal at  $Q_1$  drain; No output signal  
(b)  $V_{D1} \cong 0 \text{ V}$  (floating); No signal at  $Q_1$  drain; No output signal  
(c)  $V_{GS1} = 0 \text{ V}$ ;  $V_S = 0 \text{ V}$ ;  $V_{D1}$  less than normal; Clipped output signal  
(d) Correct signal at  $Q_1$  drain; No signal at  $Q_2$  gate; No output signal  
(e)  $V_{D2} = V_{DD}$ ; Correct signal at  $Q_2$  gate; No  $Q_2$  drain signal or output signal

32. (a)  $V_{out} = 0 \text{ V}$  if  $C_1$  is open.

(b)  $A_{v1} = g_m R_d = 5000 \mu\text{S}(1.5 \text{ k}\Omega) = 7.5$

$$A_{v2} = \frac{g_m R_d}{1 + g_m R_s} = \frac{7.5}{1 + (5000 \mu\text{S})(470 \Omega)} = 2.24$$

$$A_v = A_{v1} A_{v2} = (7.5)(2.24) = 16.8$$

$$V_{out} = A_v V_{in} = (16.8)(10 \text{ mV}) = 168 \text{ mV}$$

- (c) No effect on  $V_{out}$  unless  $V_D$  is so low that clipping occurs.

- (d) No  $V_{out}$  because there is no signal at the  $Q_2$  gate.

### System Application Problems

33. The  $10 \mu\text{F}$  capacitor between the drain of  $Q_1$  and the gate of  $Q_2$  is open.

34. At test point 2: 250 mV is correct  
At test point 3: 800 mV is approximately correct  
At test point 4: 530 mV is too low  
At test point 5: 2.12 V is too low but consistent with TP4  
Most likely, the coupling capacitor between stage 1 and stage 2 is leaky. Replace.

35.  $V_{D2} = 12 \text{ V} - (5.10 \text{ mA})(1.5 \text{ k}\Omega) = 4.35 \text{ V}$

$$V_{d1} = (100 \text{ mV})(2200 \mu\text{S})(1.5 \text{ k}\Omega) = 330 \text{ mV}$$

$$V_{d2} = (330 \text{ mV})(2600 \mu\text{S})(1.5 \text{ k}\Omega) = 1.29 \text{ V rms}$$

**Data Sheet Problems**

36. The 2N3796 FET is an *n*-channel D-MOSFET.
37. (a) For a 2N3796, the typical  $V_{GS(off)} = -3.0$  V  
 (b) For a 2N3797,  $V_{DS(max)} = 20$  V  
 (c) At  $T_A = 25^\circ\text{C}$ ,  $P_{D(max)} = 200$  mW  
 (d) For a 2N3797,  $V_{GS(max)} = \pm 10$  V
38.  $P_D = 200 \text{ mW} - (1.14 \text{ mW}/^\circ\text{C})(55^\circ\text{C} - 25^\circ\text{C}) = 166 \text{ mW}$
39. For a 2N3796 with  $f = 1$  kHz,  $g_{m0} = 900 \mu\text{S}$  minimum
40. At  $V_{GS} = 3.5$  V and  $V_{DS} = 10$  V,  
 $I_{D(min)} = 9.0$  mA,  $I_{D(typ)} = 14$  mA,  $I_{D(max)} = 18$  mA
41. For a zero-biased 2N3796,  $I_{D(typ)} = 1.5$  mA
42.  $A_{v(max)} = (1800 \mu\text{S})(2.2 \text{ k}\Omega) = 3.96$

**Advanced Problems**

43.  $R_{d(min)} = 1.0 \text{ k}\Omega \parallel 4 \text{ k}\Omega = 800 \Omega$   
 $A_{v(min)} = (2.5 \text{ mS})(800 \Omega) = 2.0$   
 $R_{d(max)} = 1.0 \text{ k}\Omega \parallel 10 \text{ k}\Omega = 909 \Omega$   
 $A_{v(max)} = (7.5 \text{ mS})(909 \Omega) = 6.82$
44.  $I_{DSS(typ)} = 2.9$  mA  
 $R_D + R_S = \frac{12 \text{ V}}{2.9 \text{ mA}} = 414 \text{ k}\Omega$   
 $\frac{1}{g_m} = \frac{1}{2300 \mu\text{S}} = 435 \Omega$   
 If  $R_S = 0 \Omega$ , then  $R_D \cong 4 \text{ k}\Omega$  (3.9 k $\Omega$  standard)  
 $A_v = (2300 \mu\text{S})(3.9 \text{ k}\Omega) = 8.97$   
 $V_{DS} = 24 \text{ V} - (2.9 \text{ mA})(3.9 \text{ k}\Omega) = 24 \text{ V} - 11.3 \text{ V} = 12.7 \text{ V}$   
 The circuit is a common-source zero-biased amplifier with a drain resistor of 3.9 k $\Omega$ .
45. To maintain  $V_{DS} = 12$  V for the range of  $I_{DSS}$  values:  
 For  $I_{DSS(min)} = 2$  mA  
 $R_D = \frac{12 \text{ V}}{2 \text{ mA}} = 6 \text{ k}\Omega$   
 For  $I_{DSS(max)} = 6$  mA  
 $R_D = \frac{12 \text{ V}}{6 \text{ mA}} = 2 \text{ k}\Omega$   
 To maintain  $A_v = 9$  for the range of  $g_m(v_{fs})$  values:  
 For  $g_{m(min)} = 1500 \mu\text{S}$

## Chapter 8

---

$$R_D = \frac{9}{1500 \mu\text{S}} = 6 \text{ k}\Omega$$

For  $g_{m(\text{max})} = 3000 \mu\text{S}$

$$R_D = \frac{9}{3000 \mu\text{S}} = 3 \text{ k}\Omega$$

A drain resistance consisting of a 2.2 k $\Omega$  fixed resistor in series with a 5 k $\Omega$  variable resistor will provide more than sufficient range to maintain a gain of 9 over the specified range of  $g_m$  values. The dc voltage at the drain will vary with adjustment and depends on  $I_{\text{DSS}}$ .

The circuit cannot be modified to maintain both  $V_{\text{DS}} = 12 \text{ V}$  and  $A_v = 9$  over the full range of transistor parameter values.

### EWB/Multisim Troubleshooting Problems

The solutions showing instrument connections for Problems 46 through 54 are available in the Solutions folder for Chapter 8 on the CD-ROM provided with the textbook. The solutions may be accessed using the password *ED5FLOYD*. The faults in the circuit files may be accessed using the password *book* (all lowercase).

- 46. Drain-source shorted
- 47.  $C_2$  open
- 48.  $C_1$  open
- 49.  $R_S$  shorted
- 50. Drain-source open
- 51.  $R_1$  open
- 52.  $R_D$  open
- 53.  $R_2$  open
- 54.  $C_2$  open



# Chapter 9

## Power Amplifiers

### Section 9-1 Class A Power Amplifiers

1. (a)  $V_B = \left( \frac{R_2}{R_1 + R_2} \right) V_{CC} = \left( \frac{330 \Omega}{1.0 \text{ k}\Omega + 330 \text{ k}\Omega} \right) 15 \text{ V} = 3.72 \text{ V}$   
 $V_E = V_B - V_{BE} = 3.72 - 0.7 \text{ V} = 3.02 \text{ V}$   
 $I_{CQ} \cong I_E = \frac{V_E}{R_{E1} + R_{E2}} = \frac{3.02 \text{ V}}{8.2 \Omega + 36 \Omega} = 68.4 \text{ mA}$   
 $V_{CEQ} = V_{CC} - (I_C)(R_{E1} + R_{E2} + R_L)$   
 $= 15 \text{ V} - (68.4 \text{ mA})(8.2 \Omega + 35 \Omega + 100 \Omega) = 5.14 \text{ V}$

(b)  $A_v = \frac{R_L}{R_{E1} + r'_e} = \frac{100 \Omega}{8.2 \Omega + 0.37 \Omega} = 11.7$   
 $R_{in} = \beta_{ac}(R_{E1} + r'_e) \parallel R_1 \parallel R_2$   
 $= 100(8.2 \Omega + 0.37 \Omega) \parallel 330 \Omega \parallel 1.0 \text{ k}\Omega = 192 \Omega$   
 $A_p = A_v^2 \left( \frac{R_{in}}{R_L} \right) = 11.7^2 \left( \frac{192 \Omega}{100 \Omega} \right) = 263$

The computed voltage and power gains are slightly higher if  $r'_e$  is ignored.

2. (a) If  $R_L$  is removed, there is no collector current; hence, the power dissipated in the transistor is **zero**.
- (b) Power is dissipated only in the bias resistors plus a small amount in  $R_{E1}$  and  $R_{E2}$ . Since the load resistor has been removed, the base voltage is altered. The base voltage can be found from the Thevenin equivalent drawn for the bias circuit in Figure 9-1.

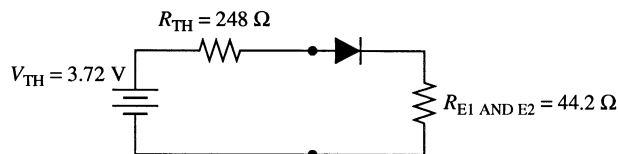

**Figure 9-1**

Applying the voltage-divider rule and including the base-emitter diode drop of 0.7 V result in a base voltage of 1.2 V. The power supply current is then computed as

$$I_{CC} = \frac{V_{CC} - 1.2 \text{ V}}{R_1} = \frac{15 \text{ V} - 1.2 \text{ V}}{1.0 \text{ k}\Omega} = 13.8 \text{ mA}$$

## Chapter 9

Power from the supply is then computed as

$$P_T = I_{CC}V_{CC} = (13.8 \text{ mA})(15 \text{ V}) = \mathbf{207 \text{ mW}}$$

(c)  $A_v = 11.7$  (see problem 1(b)).  $V_{in} = 500 \text{ mV}_{pp} = 177 \text{ mV}_{rms}$ .

$$V_{out} = A_v V_{in} = (11.7)(177 \text{ mV}) = 2.07 \text{ V}$$

$$P_{out} = \frac{V_{out}^2}{R_L} = \frac{2.07 \text{ V}^2}{100 \Omega} = \mathbf{42.8 \text{ mW}}$$

3. The changes are shown in Figure 9-2. The advantage of this arrangement is that the load resistor is referenced to ground.

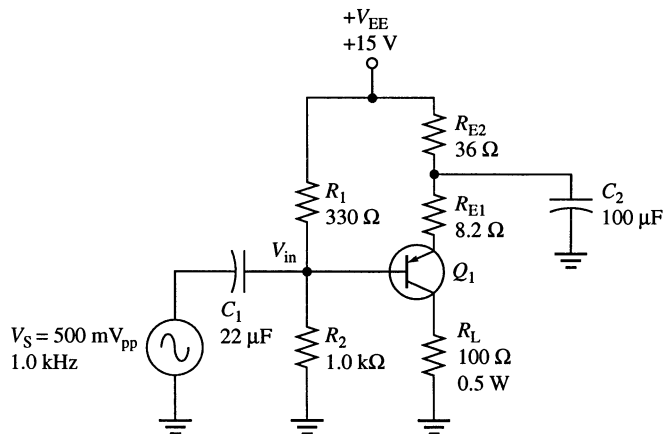

Figure 9-2

4. A CC amplifier has a voltage gain of approximately 1. Therefore,

$$A_p = \frac{R_{in}}{R_{out}} = \frac{2.2 \text{ k}\Omega}{50 \Omega} = \mathbf{44}$$

5. (a)  $R_{IN(\text{base})} = \beta_{DC}(R_{E1} + R_{E2}) = (125)(79.7) = 9.96 \text{ k}\Omega$

Since  $R_{IN(\text{base})} > 10R_2$ , it can be neglected.

$$V_B = \left[ \frac{R_2}{R_1 + R_2} \right] V_{CC} = \left( \frac{510 \Omega}{680 \Omega + 510 \Omega} \right) 12 \text{ V} = \left( \frac{510 \Omega}{1190 \Omega} \right) 12 \text{ V} = 5.14 \text{ V}$$

$$V_E = V_B - 0.7 \text{ V} = 5.14 \text{ V} - 0.7 \text{ V} = 4.44 \text{ V}$$

$$I_{CQ} \cong I_E = \frac{V_E}{R_E} = \frac{4.44 \text{ V}}{79.7 \Omega} = 55.7 \text{ mA}$$

$$V_{CQ} = V_{CC} - I_{CQ}R_C = 12 \text{ V} - (55.7 \text{ mA})(100 \Omega) = 6.43 \text{ V}$$

$$V_{CEQ} = V_C - V_E = 6.43 \text{ V} - 4.44 \text{ V} = 1.99 \text{ V}$$

$$R_c = R_C \parallel R_L = 100 \Omega \parallel 100 \Omega = 50 \Omega$$

$$V_{ce(\text{cutoff})} = V_{CEQ} + I_{CQ}R_c = 1.99 \text{ V} + 55.7 \text{ mA}(50 \Omega) = 4.78 \text{ V}$$

Since  $V_{CEQ}$  is closer to saturation,  $I_c$  is limited to

$$I_{c(p)} = \frac{V_{CEQ}}{R_c} = \frac{1.99 \text{ V}}{50 \Omega} = \mathbf{39.8 \text{ mA}}$$

$V_{out}$  is limited to

$$V_{out(p)} = V_{CEQ} = \mathbf{1.99 \text{ V}}$$

(b)  $R_{IN(base)} = \beta_{DC}(R_{E1} + R_{E2}) = (120)(142 \Omega) = 17 \text{ k}\Omega$

Since  $R_{IN(base)} < 10R_2$ , it is taken into account.

$$V_B = \left[ \frac{R_2 \parallel R_{IN(base)}}{R_1 + R_2 \parallel R_{IN(base)}} \right] V_{CC} = \left( \frac{4.7 \text{ k}\Omega \parallel 17 \text{ k}\Omega}{12 \text{ k}\Omega + 4.7 \text{ k}\Omega \parallel 17 \text{ k}\Omega} \right) 12 \text{ V} = \left( \frac{3.68 \text{ k}\Omega}{15.68 \text{ k}\Omega} \right) 12 \text{ V} = 2.82 \text{ V}$$

$$V_E = V_B - 0.7 \text{ V} = 2.82 \text{ V} - 0.7 \text{ V} = 2.12 \text{ V}$$

$$I_{CQ} \cong I_E = V_E / R_E = 2.12 \text{ V} / 142 \Omega = 14.9 \text{ mA}$$

$$V_{CQ} = V_{CC} - I_{CQ}R_C = 12 \text{ V} - (14.9 \text{ mA})(470 \Omega) = 5.0 \text{ V}$$

$$V_{CEQ} = V_{CQ} - V_E = 5.0 \text{ V} - 2.12 \text{ V} = 2.88 \text{ V}$$

$$R_c = R_C \parallel R_L = 470 \Omega \parallel 470 \Omega = 235 \Omega$$

$$V_{ce(cutoff)} = V_{CEQ} + I_{CQ}R_c = 2.88 \text{ V} + 14.9 \text{ mA}(235 \Omega) = 6.38 \text{ V}$$

Since  $V_{CEQ}$  is closer to saturation,  $I_c$  is limited to

$$I_{c(p)} = \frac{V_{CEQ}}{R_c} = \frac{2.88 \text{ V}}{235 \Omega} = 12.3 \text{ mA}$$

$$V_{out} \text{ is limited to } V_{out(p)} = V_{CEQ} = 2.88 \text{ V}$$

6. (a)  $A_p = A_v^2 \left( \frac{R_{in}}{R_L} \right)$

$$A_v \cong \frac{R_c}{R_{E1}} = \frac{R_C \parallel R_L}{R_{E1}} = \frac{100 \Omega \parallel 100 \Omega}{4.7 \Omega} = \frac{50 \Omega}{4.7 \Omega} = 10.6$$

$$R_{in} = R_1 \parallel R_2 \parallel R_{in(base)} = R_1 \parallel R_2 \parallel \beta_{ac}R_{E1}$$

$$R_{in} = 680 \Omega \parallel 510 \Omega \parallel (125)(4.7 \Omega) = 680 \Omega \parallel 510 \Omega \parallel 588 \Omega = 195 \Omega$$

$$A_p = (10.6)^2 \left( \frac{195 \Omega}{100 \Omega} \right) = 219$$

(b)  $A_v \cong \frac{R_c}{R_{E1}} = \frac{R_C \parallel R_L}{R_{E1}} = \frac{470 \Omega \parallel 470 \Omega}{22 \Omega} = \frac{235 \Omega}{22 \Omega} = 10.7$

$$R_{in} = 12 \text{ k}\Omega \parallel 4.7 \text{ k}\Omega \parallel (120)(22 \Omega) = 12 \text{ k}\Omega \parallel 4.7 \text{ k}\Omega \parallel 2.64 \text{ k}\Omega = 1.48 \text{ k}\Omega$$

$$A_p = (10.7)^2 \left( \frac{1.48 \text{ k}\Omega}{470 \Omega} \right) = 361$$

## Chapter 9

7.  $R_{IN(base)} = \beta_{DC} R_E = 90(130 \Omega) = 11.7 \text{ k}\Omega$   
 $R_2 \parallel R_{IN(base)} = 1.0 \text{ k}\Omega \parallel 11.7 \text{ k}\Omega = 921 \Omega$   
 $V_B = \left( \frac{R_2 \parallel R_{IN(base)}}{R_1 + R_2 \parallel R_{IN(base)}} \right) V_{CC} = \left( \frac{921 \Omega}{5.62 \text{ k}\Omega} \right) 24 \text{ V} = 3.93 \text{ V}$   
 $V_E = V_B - 0.7 \text{ V} = 3.93 \text{ V} - 0.7 \text{ V} = 3.23 \text{ V}$   
 $I_{CQ} \cong I_E = \frac{V_E}{R_E} = \frac{3.23 \text{ V}}{130 \Omega} = 24.8 \text{ mA}$   
 $V_C = V_{CC} - I_{CQ} R_C = 24 \text{ V} - (24.8 \text{ mA})(560 \Omega) = 13.9 \text{ V}$   
 $V_{CEQ} = V_C - V_E = 13.9 \text{ V} - 3.23 \text{ V} = 10.7 \text{ V}$   
 $P_{D(min)} = P_{DQ} = I_{CQ} V_{CEQ} = (24.8 \text{ mA})(10.7 \text{ V}) = \mathbf{265 \text{ mW}}$

8. From Problem 7:  $I_{CQ} = 24.8 \text{ mA}$  and  $V_{CEQ} = 10.7 \text{ V}$   
 $V_{ce(cutoff)} = V_{CEQ} + I_{CQ} R_c = 10.7 \text{ V} + (24.8 \text{ mA})264 \Omega = 17.2 \text{ V}$   
 The  $Q$ -point is closer to cutoff than to saturation.  
 $P_{out} = 0.5 I_{CQ}^2 R_c = 0.5(24.8 \text{ mA})^2 264 \Omega = \mathbf{81.2 \text{ mW}}$   
 $eff = \frac{P_{out}}{P_{DC}} = \frac{P_{out}}{V_{CC} I_{CQ}} = \frac{P_{out}}{V_{CC} I_{CQ}} = \frac{81.2 \text{ mW}}{(24 \text{ V})(24.8 \text{ mA})} = \mathbf{0.136}$

### Section 9-2 Class B and Class AB Push-Pull Amplifiers

9. (a)  $V_{B(Q1)} = 0 \text{ V} + 0.7 \text{ V} = \mathbf{0.7 \text{ V}}$   
 $V_{B(Q2)} = 0 \text{ V} - 0.7 \text{ V} = \mathbf{-0.7 \text{ V}}$   
 $V_E = \mathbf{0 \text{ V}}$   
 $I_{CQ} = \frac{V_{CC} - (-V_{CC}) - 1.4 \text{ V}}{R_1 + R_2} = \frac{9 \text{ V} - (-9 \text{ V}) - 1.4 \text{ V}}{1.0 \text{ k}\Omega + 1.0 \text{ k}\Omega} = \mathbf{8.3 \text{ mA}}$   
 $V_{CEQ(Q1)} = \mathbf{9 \text{ V}}$   
 $V_{CEQ(Q2)} = \mathbf{-9 \text{ V}}$

(b)  $V_{out} = V_{in} = 5.0 \text{ V rms}$   
 $P_{out} = \frac{(V_{out})^2}{R_L} = \frac{5.0 \text{ V}^2}{50 \Omega} = \mathbf{0.5 \text{ W}}$

10.  $I_{c(sat)} = \frac{V_{CC}}{R_L} = \frac{9.0 \text{ V}}{50 \Omega} = 180 \text{ mA}$   
 $V_{ce(cutoff)} = 9 \text{ V}$

These points define the ac load line as shown in Figure 9-3. The  $Q$ -point is at a collector current of 8.3 mA (see problem 9) and the dc load line rises vertically through this point.

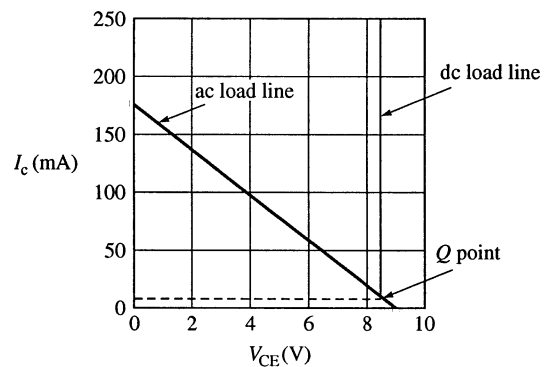

Figure 9-3

11. (a)  $V_{B(Q1)} = 7.5 \text{ V} + 0.7 \text{ V} = \mathbf{8.2 \text{ V}}$   
 $V_{B(Q2)} = 7.5 \text{ V} - 0.7 \text{ V} = \mathbf{6.8 \text{ V}}$   
 $V_E = \frac{15 \text{ V}}{2} = \mathbf{7.5 \text{ V}}$   
 $I_{CQ} = \frac{V_{CC} - 1.4 \text{ V}}{R_1 + R_2} = \frac{15 \text{ V} - 1.4 \text{ V}}{1.0 \text{ k}\Omega + 1.0 \text{ k}\Omega} = \mathbf{6.8 \text{ mA}}$   
 $V_{CEQ(Q1)} = 15 \text{ V} - 7.5 \text{ V} = \mathbf{7.5 \text{ V}}$   
 $V_{CEQ(Q2)} = 0 \text{ V} - 7.5 \text{ V} = \mathbf{-7.5 \text{ V}}$
- (b)  $V_{in} = V_{out} = 10 \text{ V}_{pp} = 3.54 \text{ V rms}$   
 $P_L = \frac{(V_L)^2}{R_L} = \frac{(3.54 \text{ V})^2}{75 \Omega} = \mathbf{167 \text{ mW}}$
12. (a) Maximum peak voltage =  $7.5 \text{ V}_p$ .  $7.5 \text{ V}_p = 5.30 \text{ V rms}$   
 $P_{L(\max)} = \frac{(V_L)^2}{R_L} = \frac{(5.30 \text{ V})^2}{75 \Omega} = \mathbf{375 \text{ mW}}$
- (b) Maximum peak voltage =  $12 \text{ V}_p$ .  $12 \text{ V}_p = 8.48 \text{ V rms}$   
 $P_{L(\max)} = \frac{(V_L)^2}{R_L} = \frac{(8.48 \text{ V})^2}{75 \Omega} = \mathbf{960 \text{ mW}}$
13. (a)  $C_2$  open or  $Q_2$  open  
 (b) power supply off, open  $R_1$ ,  $Q_1$  base shorted to ground  
 (c)  $Q_1$  has collector-to-emitter short  
 (d) one or both diodes shorted
14. (a)  $I_{R1} \cong \frac{V_{DD} - (-V_{DD})}{R_1 + R_2 + R_3} = \frac{48 \text{ V}}{105.6 \text{ k}\Omega} = 455 \mu\text{A}$   
 $V_B = V_{DD} - I_{R1}(R_1 + R_2) = 24 \text{ V} - 455 \mu\text{A}(5.6 \text{ k}\Omega) = 21.5 \text{ V}$   
 $V_E = V_B + 0.7 \text{ V} = 21.5 \text{ V} + 0.7 \text{ V} = 22.2 \text{ V}$   
 $I_E = \frac{V_{DD} - V_E}{R_4 + R_5} = \frac{24 \text{ V} - 22.2 \text{ V}}{1.1 \text{ k}\Omega} = 1.64 \text{ mA}$   
 $V_{R6} = V_{TH(Q1)} - V_{TH(Q2)} = 2.75 \text{ V} - (-2.75 \text{ V}) = 5.5 \text{ V}$   
 $R_6 = \frac{V_{R6}}{I_{R6}} \cong \frac{V_{R6}}{I_E} = \frac{5.5 \text{ V}}{1.64 \text{ mA}} = \mathbf{3.35 \text{ k}\Omega}$
- (b)  $r'_e \cong \frac{25 \text{ mV}}{I_E} = \frac{25 \text{ mV}}{1.64 \text{ mA}} = 15.2 \Omega$   
 $A_v = \frac{R_7}{R_5 + r'_e} = \frac{15 \text{ k}\Omega}{115.2 \Omega} = 130$   
 $V_{out} = A_v V_{in} = 130(50 \text{ mV}) = \mathbf{6.5 \text{ V}}$
- (c)  $P_L = \frac{V_{out}^2}{R_L} = \frac{(6.5 \text{ V})^2}{33 \Omega} = \mathbf{1.28 \text{ W}}$

## Chapter 9

---

### Section 9-3 Class C Amplifiers

$$15. \quad P_{D(\text{avg})} = \left(\frac{t_{\text{on}}}{T}\right) V_{CE(\text{sat})} I_{C(\text{sat})} = (0.1)(0.18 \text{ V})(25 \text{ mA}) = 450 \mu\text{W}$$

$$16. \quad f_r = \frac{1}{2\pi\sqrt{LC}} = \frac{1}{2\pi\sqrt{(10 \text{ mH})(0.001 \mu\text{F})}} = 50.3 \text{ kHz}$$

$$17. \quad V_{\text{out(pp)}} = 2V_{CC} = 2(12 \text{ V}) = 24 \text{ V}$$

$$18. \quad P_{\text{out}} = \frac{0.5V_{CC}^2}{R_c} = \frac{0.5(15 \text{ V})^2}{50 \Omega} = 2.25 \text{ W}$$

$$P_{D(\text{avg})} = \left(\frac{t_{\text{on}}}{T}\right) V_{CE(\text{sat})} I_{C(\text{sat})} = (0.1)(0.18 \text{ V})(25 \text{ mA}) = 0.45 \text{ mW}$$

$$\eta = \frac{P_{\text{out}}}{P_{\text{out}} + P_{D(\text{avg})}} = \frac{2.25 \text{ W}}{2.25 \text{ W} + 0.45 \text{ mW}} = 0.9998$$

### Section 9-4 Troubleshooting

19. With  $C_1$  open, only the negative half of the input signal appears across  $R_L$ .
20. One of the transistors is open between the collector and emitter or a coupling capacitor is open.
21.
  - (a) No dc supply voltage
  - (b) Diode  $D_1$  or  $D_2$  open
  - (c) Circuit is OK
  - (d)  $Q_1$  shorted from collector to emitter

### System Application Problems

22. For the block diagram of textbook Figure 9-34 with no signal from the power amplifier or preamplifier, but with the microphone working, the problem is in the power amplifier or preamplifier. Check for an output from the preamp. If one is present, the preamp is not at fault.
23. For the circuit of Figure 9-35 with the base-emitter junction of the 2N6043 open, the dc output will be approximately 6 V with a signal output having the positive alternations of the input signal.
24. For the circuit of Figure 9-35 with the base-emitter junction of the 2N6040 open, the dc output will be 0 V with no signal output.
25. On the circuit board of Figure 9-49, the input coupling capacitor  $C_1$  has been installed backwards. The positive lead should connect into the circuit.

**Data Sheet Problems**

26. From the 2N6040 data sheet of textbook Figure 9-36:  
 (a)  $\beta_{DC(min)} = 100 @ I_C = 8.0 \text{ A}, V_{CE} = 4 \text{ V}$   
 $\beta_{DC(min)} = 1000 @ I_C = 4.0 \text{ A}, V_{CE} = 4 \text{ V}$   
 (b) For a 2N6041,  $V_{CE(max)} = 80 \text{ V}$   
 (c)  $P_{D(max)} = 75 \text{ W} @ T_C = 25^\circ\text{C}$   
 (d)  $I_{C(max)} = 8.0 \text{ A continuous or } 16.0 \text{ A peak}$
27.  $P_D = 75 \text{ W} - (65^\circ\text{C} - 25^\circ\text{C})(0.6 \text{ W}/^\circ\text{C}) = 75 \text{ W} - 24 \text{ W} = 51 \text{ W}$
28.  $P_D = 2.2 \text{ W} - (80^\circ\text{C} - 25^\circ\text{C})(0.0175 \text{ W}/^\circ\text{C}) = 2.2 \text{ W} - 963 \text{ mW} = 1.24 \text{ W}$
29. As the frequency increases, the small-signal current gain **decreases**.
30.  $h_{fe} \cong 2800 @ f = 2 \text{ kHz}$   
 $h_{fe} \cong 700 @ f = 100 \text{ kHz}$

**Advanced Problems**

31.  $T_C$  is much closer to the actual junction temperature than  $T_A$ . In a given operating environment,  $T_A$  is always less than  $T_C$ .

32.  $I_{C(sat)} = \frac{24 \text{ V}}{330 \Omega + 100 \Omega} = \frac{24 \text{ V}}{430 \Omega} = 55.8 \text{ mA}$

$V_{CE(cutoff)} = 24 \text{ V}$

$V_{BQ} = \left( \frac{1.0 \text{ k}\Omega}{1.0 \text{ k}\Omega + 4.7 \text{ k}\Omega} \right) 24 \text{ V} = 4.21 \text{ V}$

$V_{EQ} = 4.21 \text{ V} - 0.7 \text{ V} = 3.51 \text{ V}$

$I_{EQ} \cong I_{CQ} = \frac{3.51 \text{ V}}{100 \Omega} = 35.1 \text{ mA}$

$R_c = 330 \Omega \parallel 330 \Omega = 165 \Omega$

$V_{CQ} = 24 \text{ V} - (35.1 \text{ mA})(165 \Omega) = 12.4 \text{ V}$

$V_{CEQ} = 12.4 \text{ V} - 3.51 \text{ V} = 8.90 \text{ V}$

$I_{c(sat)} = 35.1 \text{ mA} + \frac{8.90 \text{ V}}{165 \Omega} = 89.1 \text{ mA}$

$V_{ce(cutoff)} = 8.90 \text{ V} - (35.1 \text{ mA})(165 \Omega) = 14.7 \text{ V}$

See Figure 9-4.

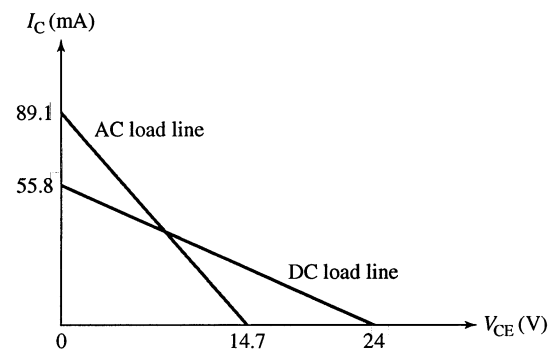

Figure 9-4

## Chapter 9

33. See Figure 9-5.

$$I_{R1} \cong I_{R2} = \frac{15 \text{ V}}{86 \Omega} = 174 \text{ mA}$$

$$V_B \cong \left( \frac{18 \Omega}{86 \Omega} \right) 15 \text{ V} = 3.14 \text{ V}$$

$$V_E = 3.14 \text{ V} - 0.7 \text{ V} = 2.44 \text{ V}$$

$$I_E \cong I_C = \frac{2.44 \text{ V}}{4.85 \Omega} = 503 \text{ mA}$$

$$V_C = 15 \text{ V} - (10 \Omega)(503 \text{ mA}) = 9.97 \text{ V}$$

$$V_{CE} = 7.53 \text{ V}$$

$$r'_e = \frac{25 \text{ mV}}{503 \text{ mA}} = 0.05 \Omega$$

The ac resistance affecting the load line is

$$R_c + R_e + r'_e = 10 \Omega$$

$$\beta_{ac} = \beta_{DC} \geq 100$$

$$I_{c(sat)} = 503 \text{ mA} + \frac{7.53 \text{ V}}{10.2 \Omega} = 1.24 \text{ A}$$

$$V_{ce(cutoff)} = 7.53 \text{ V} + (503 \text{ mA})(10.2 \Omega) = 12.7 \text{ V}$$

The  $Q$ -point is closer to cutoff so

$$P_{out} = (0.5)(503 \text{ mA})^2(10.2 \Omega) = 1.29 \text{ W}$$

As loading occurs, the  $Q$ -point will still be closer to cutoff. The circuit will have

$$P_{out} \geq 1 \text{ W for } R_L \geq 37.7 \Omega. \text{ (39 } \Omega \text{ standard)}$$

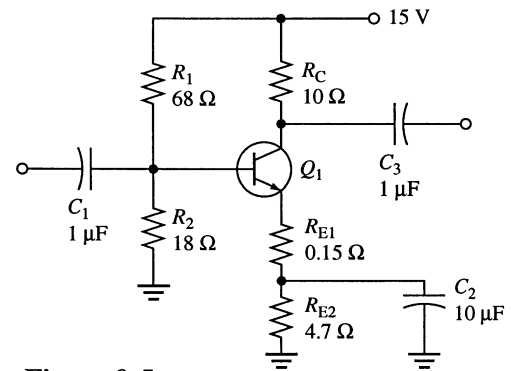

Figure 9-5

34. To modify the circuit of textbook Figure 9-39, to operate on dc power for 8 hours continuously, remove the rectifier connections (with a switch possibly) and connect the power terminals of the preamp and amplifier boards to a 12 V battery (possibly with the same switch as that which disconnects the power supply). Because the preamp operates on 9 V, a zener or other regulator must be used to set the proper voltage on this board.

### EWB/Multisim Troubleshooting Problems

The solutions showing instrument connections for Problems 35 through 39 are available in the Solutions folder for Chapter 9 on the CD-ROM provided with the textbook. The solutions may be accessed using the password *ED5FLOYD*. The faults in the circuit files may be accessed using the password *book* (all lowercase).

35.  $C_{in}$  open

36.  $R_{E2}$  open

37.  $Q_1$  collector-emitter open

38.  $D_2$  shorted

39.  $Q_2$  drain-source open



# Chapter 10

## Amplifier Frequency Response

---

### Section 10-1 Basic Concepts

1. If  $C_1 = C_2$ , the critical frequencies are equal, and they will both cause the gain to decrease at 40 dB/decade below  $f_c$ .
2. At sufficiently high frequencies, the reactances of the coupling capacitors become very small and the capacitors appear effectively as shorts; thus, negligible signal voltage is dropped across them.
3. BJT:  $C_{be}$ ,  $C_{bc}$ , and  $C_{ce}$   
FET:  $C_{gs}$ ,  $C_{gd}$ , and  $C_{ds}$
4. Low-frequency response:  $C_1$ ,  $C_2$ , and  $C_3$   
High-frequency response:  $C_{bc}$ ,  $C_{be}$ , and  $C_{ce}$

$$5. \quad V_E \cong \left( \frac{R_2}{R_1 + R_2} \right) V_{CC} - 0.7 \text{ V} = \left( \frac{4.7 \text{ k}\Omega}{37.7 \text{ k}\Omega} \right) 20 \text{ V} - 0.7 \text{ V} = 1.79 \text{ V}$$

$$I_E = \frac{V_E}{R_E} = \frac{1.79 \text{ V}}{560 \Omega} = 3.2 \text{ mA}$$

$$r'_e = \frac{25 \text{ mV}}{3.2 \text{ mA}} = 7.8 \Omega$$

$$A_v = \frac{R_c}{r'_e} = \frac{2.2 \text{ k}\Omega \parallel 5.6 \text{ k}\Omega}{7.8 \Omega} = 202$$

$$C_{in(miller)} = C_{bc}(A_v + 1) = 4 \text{ pF}(202 + 1) = \mathbf{812 \text{ pF}}$$

$$6. \quad C_{out(miller)} = C_{bc} \left( \frac{A_v + 1}{A_v} \right) = 4 \text{ pF} \left( \frac{203}{202} \right) = \mathbf{4 \text{ pF}}$$

7.  $I_D = 3.36 \text{ mA}$  using Eq. 8-5 and a programmable calculator.

$$V_{GS} = -(3.36 \text{ mA})(1.0 \text{ k}\Omega) = -3.36 \text{ V}$$

$$g_{m0} = \frac{2(10 \text{ mA})}{8 \text{ V}} = 2.5 \text{ mS}$$

$$g_m = (2.5 \text{ mS}) \left( 1 - \frac{3.36 \text{ V}}{8 \text{ V}} \right) = 1.45 \text{ mS}$$

$$A_v = g_m R_d = (1.45 \text{ mS})(1.0 \text{ k}\Omega \parallel 10 \text{ k}\Omega) = 1.32$$

$$C_{gd} = C_{rss} = 3 \text{ pF}$$

$$C_{in(miller)} = C_{gd}(A_v + 1) = 3 \text{ pF}(2.32) = \mathbf{6.95 \text{ pF}}$$

$$C_{out(miller)} = C_{gd} \left( \frac{A_v + 1}{A_v} \right) = 3 \text{ pF} \left( \frac{2.32}{1.32} \right) = \mathbf{5.28 \text{ pF}}$$

## Chapter 10

### Section 10-2 The Decibel

8.  $A_p = \frac{P_{out}}{P_{in}} = \frac{5 \text{ W}}{0.5 \text{ W}} = 10$

$$A_p(\text{dB}) = 10 \log \left( \frac{P_{out}}{P_{in}} \right) = 10 \log 10 = \mathbf{10 \text{ dB}}$$

9.  $V_{in} = \frac{V_{out}}{A_v} = \frac{1.2 \text{ V}}{50} = \mathbf{24 \text{ mV rms}}$

$$A_v(\text{dB}) = 20 \log(A_v) = 20 \log 50 = \mathbf{34.0 \text{ dB}}$$

10. The gain reduction is  $20 \log \left( \frac{25}{65} \right) = \mathbf{-8.3 \text{ dB}}$

11. (a)  $10 \log \left( \frac{2 \text{ mW}}{1 \text{ mW}} \right) = \mathbf{3.01 \text{ dBm}}$

(b)  $10 \log \left( \frac{1 \text{ mW}}{1 \text{ mW}} \right) = \mathbf{0 \text{ dBm}}$

(c)  $10 \log \left( \frac{4 \text{ mW}}{1 \text{ mW}} \right) = \mathbf{6.02 \text{ dBm}}$

(d)  $10 \log \left( \frac{0.25 \text{ mW}}{1 \text{ mW}} \right) = \mathbf{-6.02 \text{ dBm}}$

12.  $V_B = \left( \frac{4.7 \text{ k}\Omega}{37.7 \text{ k}\Omega} \right) 20 \text{ V} = 1.79 \text{ V}$

$$I_E = \frac{1.79 \text{ V}}{560 \Omega} = 3.20 \text{ mA}$$

$$r'_e = \frac{25 \text{ mV}}{3.2 \text{ mA}} = 7.81 \Omega$$

$$A_v = \frac{5.6 \text{ k}\Omega \parallel 2.2 \text{ k}\Omega}{7.81 \Omega} = 202$$

$$A_{v(\text{dB})} = 20 \log(202) = \mathbf{46.1 \text{ dB}}$$

At the critical frequencies,

$$A_{v(\text{dB})} = 46.1 \text{ dB} - 3 \text{ dB} = \mathbf{43.1 \text{ dB}}$$

### Section 10-3 Low-Frequency Amplifier Response

13. (a)  $f_c = \frac{1}{2\pi RC} = \frac{1}{2\pi(100 \Omega)(5 \mu\text{F})} = \mathbf{318 \text{ Hz}}$

(b)  $f_c = \frac{1}{2\pi RC} = \frac{1}{2\pi(1.0 \text{ k}\Omega)(0.1 \mu\text{F})} = \mathbf{1.59 \text{ kHz}}$

14.  $R_{IN(base)} = \beta_{DC} R_E = 12.5 \text{ k}\Omega$

$$V_E = \left( \frac{R_2 \parallel R_{IN(base)}}{R_1 + R_2 \parallel R_{IN(base)}} \right) 9 \text{ V} - 0.7 \text{ V} = \left( \frac{4.7 \text{ k}\Omega \parallel 12.5 \text{ k}\Omega}{12 \text{ k}\Omega + 4.7 \text{ k}\Omega \parallel 12.5 \text{ k}\Omega} \right) 9 \text{ V} - 0.7 \text{ V} = 1.3 \text{ V}$$

$$I_E = \frac{V_E}{R_E} = \frac{1.3 \text{ V}}{100 \Omega} = 13 \text{ mA}$$

$$r'_e = \frac{25 \text{ mV}}{13 \text{ mA}} = 1.92 \Omega$$

$$R_{in(base)} = \beta_{ac} r'_e = (125)(1.92 \Omega) = 240 \Omega$$

$$R_{in} = 50 \Omega + R_{in(base)} \parallel R_1 \parallel R_2 = 50 \Omega + 240 \Omega \parallel 12 \text{ k}\Omega \parallel 4.7 \text{ k}\Omega = 274 \Omega$$

For the input network:

$$f_c = \frac{1}{2\pi R_{in} C_1} = \frac{1}{2\pi(274 \Omega)(1 \mu\text{F})} = 578 \text{ Hz}$$

For the output network:

$$f_c = \frac{1}{2\pi(R_C + R_L)C_3} = \frac{1}{2\pi(900 \Omega)(1 \mu\text{F})} = 177 \text{ Hz}$$

For the bypass network:

$$R_{TH} = R_1 \parallel R_2 \parallel R_s = 12 \text{ k}\Omega \parallel 4.7 \text{ k}\Omega \parallel 50 \Omega \cong 49.3 \Omega$$

$$f_c = \frac{1}{2\pi(r'_e + R_{TH} / \beta_{DC} \parallel R_E)C_2} = \frac{1}{2\pi(2.31 \Omega)(10 \mu\text{F})} = 6.89 \text{ kHz}$$

$$A_v = \frac{R_C \parallel R_L}{r'_e} = \frac{220 \Omega \parallel 680 \Omega}{1.92 \Omega} = 86.6$$

$$A_v(\text{dB}) = 20 \log(86.6) = 38.8 \text{ dB}$$

The **bypass network** produces the dominant low critical frequency. See Figure 10-1.

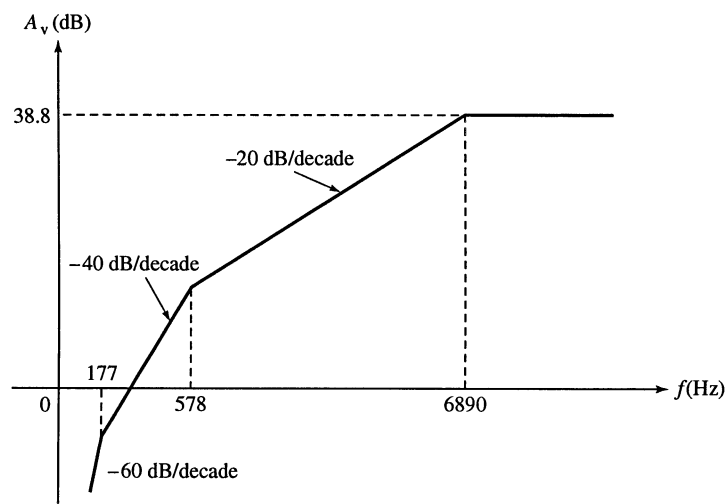

Figure 10-1

## Chapter 10

15. From Problem 14:

$$A_{v(mid)} = 86.6$$

$$A_{v(mid)} \text{ (dB)} = 38.7 \text{ dB}$$

For the input RC network:  $f_c = 578 \text{ Hz}$

For the output RC network:  $f_c = 177 \text{ Hz}$

For the bypass RC network:  $f_c = 6.89 \text{ kHz}$

The  $f_c$  of the bypass network is the dominant low critical frequency.

At  $f = f_c = 6.89 \text{ kHz}$ :

$$A_v = A_{v(mid)} - 3 \text{ dB} = 38.7 \text{ dB} - 3 \text{ dB} = \mathbf{35.7 \text{ dB}}$$

At  $f = 0.1f_c$ :

$$A_v = 38.75 \text{ dB} - 20 \text{ dB} = \mathbf{18.7 \text{ dB}}$$

At  $10f_c$  (neglecting any high frequency effects):

$$A_v = A_{v(mid)} = \mathbf{38.7 \text{ dB}}$$

16. At  $f = f_c = X_C = R$

$$\theta = \tan^{-1}\left(\frac{X_C}{R}\right) = \tan^{-1}(1) = \mathbf{45^\circ}$$

At  $f = 0.1f_c$ ,  $X_C = 10R$ .

$$\theta = \tan^{-1}(10) = \mathbf{84.3^\circ}$$

At  $f = 10f_c$ ,  $X_C = 0.1R$ .

$$\theta = \tan^{-1}(0.1) = \mathbf{5.7^\circ}$$

17.  $R_{in(gate)} = \left| \frac{V_{GS}}{I_{GSS}} \right| = \left| \frac{-10 \text{ V}}{50 \text{ nA}} \right| = 200 \text{ M}\Omega$

$$R_{in} = R_G \parallel R_{in(gate)} = 10 \text{ M}\Omega \parallel 200 \text{ M}\Omega = 9.52 \text{ M}\Omega$$

For the input network:

$$f_c = \frac{1}{2\pi R_{in} C_1} = \frac{1}{2\pi (9.52 \text{ M}\Omega)(0.005 \text{ }\mu\text{F})} = \mathbf{3.34 \text{ kHz}}$$

For the output network:

$$f_c = \frac{1}{2\pi (R_D + R_L) C_2} = \frac{1}{2\pi (560 \text{ }\Omega + 10 \text{ k}\Omega)(0.005 \text{ }\mu\text{F})} = \mathbf{3.01 \text{ kHz}}$$

The **output network is dominant**. See Figure 10-2.

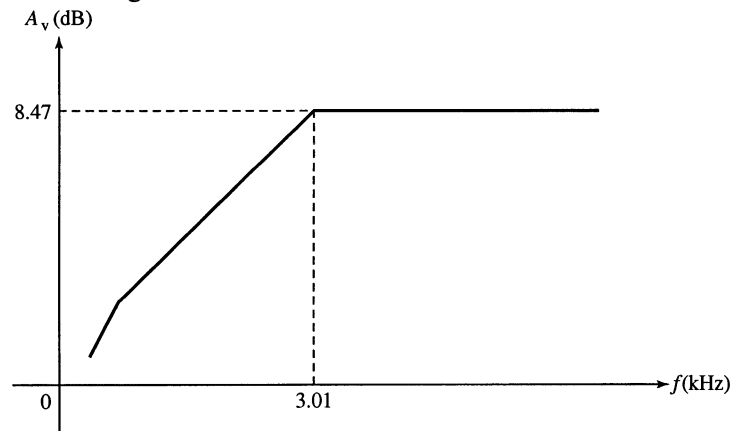

Figure 10-2

18. (a)  $g_m = g_{m0} = \frac{2(15 \text{ mA})}{6 \text{ V}} = 5 \text{ mS}$   
 $A_{v(\text{mid})} = g_m (R_D \parallel R_L) = 5 \text{ mS}(560 \Omega \parallel 10 \text{ k}\Omega) = 2.65$   
 $A_{v(\text{mid})}(\text{dB}) = 8.47 \text{ dB}$   
 At  $f_c$ :  
 $A_v = 8.47 \text{ dB} - 3 \text{ dB} = \mathbf{5.47 \text{ dB}}$   
 At  $0.1f_c$ :  
 $A_v = 8.47 \text{ dB} - 20 \text{ dB} = \mathbf{-11.5 \text{ dB}}$   
 At  $10f_c$ :  
 $A_v = A_{v(\text{mid})} = \mathbf{8.47 \text{ dB}}$  (if  $10f_c$  is still in midrange)

**Section 10-4 High-Frequency Amplifier Response**

19. From Problems 14 and 15:  
 $r'_e = 1.92 \Omega$  and  $A_{v(\text{mid})} = 86.6$   
 Input network:  
 $C_{in(\text{miller})} = C_{bc}(A_v + 1) = 10 \text{ pF}(86.6) = 876 \text{ pF}$   
 $C_T = C_{be} \parallel C_{in(\text{miller})} = 25 \text{ pF} + 876 \text{ pF} = 901 \text{ pF}$   
 $f_c = \frac{1}{2\pi(R_s \parallel R_1 \parallel R_2 \parallel \beta_{ac}r'_e)C_T} = \frac{1}{2\pi(50 \Omega \parallel 12 \text{ k}\Omega \parallel 4.7 \text{ k}\Omega \parallel 240 \Omega)901 \text{ pF}} = \mathbf{4.32 \text{ MHz}}$   
 Output network:  
 $C_{out(\text{miller})} = C_{bc} \left( \frac{A_v + 1}{A_v} \right) = 10 \text{ pF} \left( \frac{87.6}{86.6} \right) = 10.1 \text{ pF}$   
 $f_c = \frac{1}{2\pi R_c C_{out(\text{miller})}} = \frac{1}{2\pi(166 \Omega)(10.1 \text{ pF})} = \mathbf{94.9 \text{ MHz}}$   
 Therefore, the dominant high critical frequency is determined by the input network:  
 $f_c = 4.32 \text{ MHz}$ . See Figure 10-3.

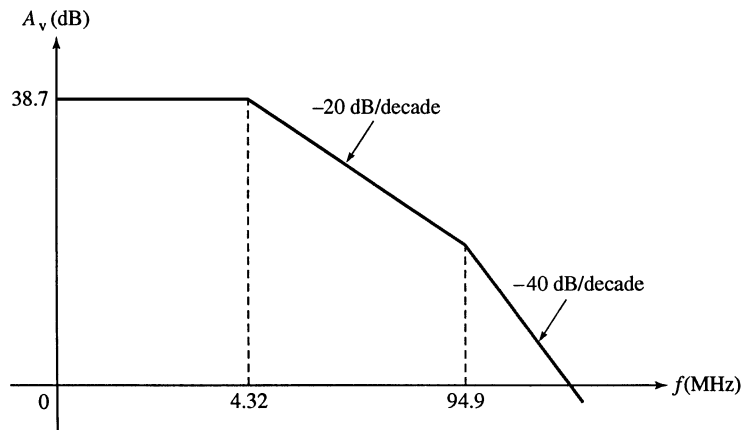

Figure 10-3

## Chapter 10

20. At  $f = 0.1f_c = 458 \text{ kHz}$ :  
 $A_v = A_{v(\text{mid})} = \mathbf{38.7 \text{ dB}}$   
 At  $f = f_c = 4.58 \text{ MHz}$ :  
 $A_v = A_{v(\text{mid})} - 3 \text{ dB} = 38.7 \text{ dB} - 3 \text{ dB} = \mathbf{35.7 \text{ dB}}$   
 At  $f = 10f_c = 45.8 \text{ MHz}$ :  
 $A_v = A_{v(\text{mid})} - 20 \text{ dB} = 38.7 \text{ dB} - 20 \text{ dB} = \mathbf{18.7 \text{ dB}}$   
 At  $f = 100f_c = 458 \text{ MHz}$ :  
 The rolloff rate changes to  $-40 \text{ dB/decade}$  at  $f = 94.6 \text{ MHz}$ . So, for frequencies from  $45.8 \text{ MHz}$  to  $94.6 \text{ MHz}$ , the rolloff rate is  $-20 \text{ dB/decade}$  and above  $94.6 \text{ MHz}$  it is  $-40 \text{ dB/decade}$ .  
 The change in frequency from  $45.8 \text{ MHz}$  to  $94.63 \text{ MHz}$  represents  

$$\frac{94.6 \text{ MHz} - 45.8 \text{ MHz}}{45.8 \text{ MHz} - 45.8 \text{ MHz}} \times 100\% = 11.8\%$$
 So, for  $11.8\%$  of the decade from  $45.8 \text{ MHz}$  to  $458 \text{ MHz}$ , the rolloff rate is  $-20 \text{ dB/decade}$  and for the remaining  $88.2\%$  of the decade, the rolloff rate is  $-40 \text{ dB/decade}$ .  
 $A_v = 18.7 \text{ dB} - (0.118)(20 \text{ dB}) - (0.882)(40 \text{ dB}) = 18.7 \text{ dB} - 2.36 \text{ dB} - 35.3 \text{ dB} = \mathbf{-19 \text{ dB}}$
21.  $C_{gd} = C_{rss} = 4 \text{ pF}$   
 $C_{gs} = C_{iss} - C_{rss} = 10 \text{ pF} - 4 \text{ pF} = 6 \text{ pF}$   
 Input network:  
 $C_{in(\text{miller})} = C_{gd}(A_v + 1) = 4 \text{ pF}(2.65 + 1) = 14.6 \text{ pF}$   
 $C_T = C_{gs} \parallel C_{in(\text{miller})} = 6 \text{ pF} + 14.6 \text{ pF} = 20.6 \text{ pF}$   

$$f_c = \frac{1}{2\pi R_s C_T} = \frac{1}{2\pi(600 \Omega)(20.6 \text{ pF})} = \mathbf{12.9 \text{ MHz}}$$
 Output network:  

$$C_{out(\text{miller})} = C_{gd} \left( \frac{A_v + 1}{A_v} \right) = 4 \text{ pF} \left( \frac{2.65 + 1}{2.65} \right) = 5.51 \text{ pF}$$

$$f_c = \frac{1}{2\pi R_d C_{out(\text{miller})}} = \frac{1}{2\pi(530 \Omega)(5.51 \text{ pF})} = \mathbf{54.5 \text{ MHz}}$$
 The input network is dominant.
22. From Problem 21: For the input network,  $f_c = 12.9 \text{ MHz}$  and for the output network,  $f_c = 54.5 \text{ MHz}$ .  
 The dominant critical frequency is  $12.9 \text{ MHz}$ .  
 At  $f = 0.1f_c = 1.29 \text{ MHz}$ :  $A_v = A_{v(\text{mid})} = \mathbf{8.47 \text{ dB}}$ ,  $\theta = 0^\circ$   
 At  $f = f_c = 12.9 \text{ MHz}$ :  $A_v = A_{v(\text{mid})} - 3 \text{ dB} = 8.47 \text{ dB} - 3 \text{ dB} = \mathbf{5.47 \text{ dB}}$ ,  $\theta = \tan^{-1}(1) = 45^\circ$   
 At  $f = 10f_c = 129 \text{ MHz}$ :  
 From  $12.9 \text{ MHz}$  to  $54.5 \text{ MHz}$  the rolloff is  $-20 \text{ dB/decade}$ . From  $54.5 \text{ MHz}$  to  $129 \text{ MHz}$  the rolloff is  $-40 \text{ dB/decade}$ .  
 The change in frequency from  $12.9 \text{ MHz}$  to  $54.5 \text{ MHz}$  represents  

$$\frac{54.5 \text{ MHz} - 12.9 \text{ MHz}}{129 \text{ MHz} - 12.9 \text{ MHz}} \times 100\% = 35.8\%$$
 So, for  $35.8\%$  of the decade, the rolloff rate is  $-20 \text{ dB/decade}$  and for  $64.2\%$  of the decade, the rate is  $-40 \text{ dB/decade}$ .  
 $A_v = 5.47 \text{ dB} - (0.358)(20 \text{ dB}) - (0.642)(40 \text{ dB}) = \mathbf{-13.1 \text{ dB}}$   
 At  $f = 100f_c = 1290 \text{ MHz}$ :  $A_v = -13.1 \text{ dB} - 40 \text{ dB} = \mathbf{-53.1 \text{ dB}}$

### Section 10-5 Total Amplifier Frequency Response

23.  $f_{cl} = 136 \text{ Hz}$   
 $f_{cu} = 8 \text{ kHz}$
24. From Problems 14 and 19:  
 $f_{cu} = 4.32 \text{ MHz}$  and  $f_{cl} = 6.89 \text{ kHz}$   
 $BW = f_{cu} - f_{cl} = 4.32 \text{ MHz} - 6.89 \text{ kHz} = 4.313 \text{ MHz}$
25.  $f_T = (BW)A_{v(mid)}$   
 $BW = \frac{f_T}{A_{v(mid)}} = \frac{200 \text{ MHz}}{38} = 5.26 \text{ MHz}$   
 Therefore,  $f_{cu} \cong BW = 5.26 \text{ MHz}$
26. 6 dB/octave rolloff:  
 At  $2f_{cu}$ :  $A_v = 50 \text{ dB} - 6 \text{ dB} = 44 \text{ dB}$   
 At  $4f_{cu}$ :  $A_v = 50 \text{ dB} - 12 \text{ dB} = 38 \text{ dB}$   
 20 dB/decade rolloff:  
 At  $10f_{cu}$ :  $A_v = 50 \text{ dB} - 20 \text{ dB} = 30 \text{ dB}$

### Section 10-6 Frequency Response of Multistage Amplifiers

27. Dominant  $f'_{cl} = 230 \text{ Hz}$   
 Dominant  $f'_{cu} = 1.2 \text{ MHz}$
28.  $BW = 1.2 \text{ MHz} - 230 \text{ Hz} \cong 1.2 \text{ MHz}$
29.  $f'_{cl} = \frac{400 \text{ Hz}}{\sqrt{2^{1/2} - 1}} = \frac{400 \text{ Hz}}{0.643} = 622 \text{ Hz}$   
 $f'_{cu} = (800 \text{ kHz})\sqrt{2^{1/2} - 1} = 0.643(800 \text{ kHz}) = 515 \text{ kHz}$   
 $BW = 515 \text{ kHz} - 622 \text{ Hz} \cong 514 \text{ kHz}$
30.  $f'_{cl} = \frac{50 \text{ Hz}}{\sqrt{2^{1/3} - 1}} = \frac{50 \text{ Hz}}{0.510} = 98.1 \text{ Hz}$
31.  $f'_{cl} = \frac{125 \text{ Hz}}{\sqrt{2^{1/2} - 1}} = \frac{125 \text{ Hz}}{0.643} = 194 \text{ Hz}$   
 $f'_{cu} = 2.5 \text{ MHz}$   
 $BW = 2.5 \text{ MHz} - 194 \text{ Hz} \cong 2.5 \text{ MHz}$

## Chapter 10

### Section 10-7 Frequency Response Measurement

$$32. \quad f_{cl} = \frac{0.35}{t_f} = \frac{0.35}{1 \text{ ms}} = 350 \text{ Hz}$$

$$f_{cu} = \frac{0.35}{t_r} = \frac{0.35}{20 \text{ ns}} = 17.5 \text{ MHz}$$

33. Increase the frequency until the output voltage drops to 3.54 V (3 dB below the midrange output voltage). This is the upper critical frequency.

$$34. \quad t_r \cong 3 \text{ div} \times 5 \text{ } \mu\text{s/div} = 15 \text{ } \mu\text{s}$$

$$t_f \cong 6 \text{ div} \times 0.1 \text{ ms/div} = 600 \text{ } \mu\text{s}$$

$$f_{cl} = \frac{0.35}{t_f} = \frac{0.35}{600 \text{ } \mu\text{s}} = 583 \text{ Hz}$$

$$f_{cu} = \frac{0.35}{t_r} = \frac{0.35}{15 \text{ } \mu\text{s}} = 23.3 \text{ kHz}$$

$$BW = 23.3 \text{ kHz} - 583 \text{ Hz} = 22.7 \text{ kHz}$$

### System Application Problems

$$35. \quad V_B = \left( \frac{13 \text{ k}\Omega}{113 \text{ k}\Omega} \right) 12 \text{ V} = 1.38 \text{ V}, V_E = 0.68 \text{ V}$$

$$I_E = 2.13 \text{ mA}, r'_e = 11.7 \text{ } \Omega$$

$$R_{in} = 22 \text{ k}\Omega \parallel 100 \text{ k}\Omega \parallel (112 \text{ } \Omega)(100) = 6.9 \text{ k}\Omega \text{ (both stages)}$$

First stage:

$$f_{cl(in)} = \frac{1}{2\pi(6.9 \text{ k}\Omega)(1 \text{ } \mu\text{F})} = 23.1 \text{ Hz}$$

$$R_{out} = 4.7 \text{ k}\Omega + 6.9 \text{ k}\Omega = 11.6 \text{ k}\Omega$$

$$f_{cl(out)} = \frac{1}{2\pi(11.6 \text{ k}\Omega)(1 \text{ } \mu\text{F})} = 13.7 \text{ Hz}$$

$$R_{bypass} = 220 \text{ } \Omega \parallel (112 \text{ } \Omega + 22 \text{ k}\Omega \parallel 100 \text{ k}\Omega / 100) = 125 \text{ } \Omega$$

$$f_{cl(bypass)} = \frac{1}{2\pi(125 \text{ } \Omega)(100 \text{ } \mu\text{F})} = 12.7 \text{ Hz}$$

Second stage:

$$f_{cl(in)} = 13.7 \text{ Hz (same as } f_{cl(out)} \text{ of first stage)}$$

$$R_{out} = 4.7 \text{ k}\Omega + 10 \text{ k}\Omega = 14.7 \text{ k}\Omega$$

$$f_{cl(out)} = \frac{1}{2\pi(14.7 \text{ k}\Omega)(1 \text{ } \mu\text{F})} = 10.8 \text{ Hz}$$

$$R_{bypass} = 220 \text{ } \Omega \parallel (112 \text{ } \Omega + 22 \text{ k}\Omega \parallel 100 \text{ k}\Omega \parallel 4.7 \text{ k}\Omega / 100) = 88.8 \text{ } \Omega$$

$$f_{cl(bypass)} = \frac{1}{2\pi(88.8 \text{ } \Omega)(100 \text{ } \mu\text{F})} = 17.9 \text{ Hz}$$

$f_{cl(in)}$  of first stage is the dominant lower critical frequency.



36. Changing to 1  $\mu\text{F}$  coupling capacitors does not significantly affect the overall bandwidth because the upper critical frequency is much greater than the dominant lower critical frequency.
37. Increasing the load resistance on the output of the second stage has no effect on the dominant lower critical frequency because the critical frequency of the output circuit will decrease and the critical frequency of the first stage input circuit will remain dominant.

38.  $V_B = \left( \frac{13 \text{ k}\Omega}{113 \text{ k}\Omega} \right) 12 \text{ V} = 1.38 \text{ V}, V_E = 0.68 \text{ V}$

$$I_E = 2.13 \text{ mA}, r'_e = 11.7 \Omega$$

$$R_{in} = 22 \text{ k}\Omega \parallel 100 \text{ k}\Omega \parallel (112 \Omega)(100) = 6.9 \text{ k}\Omega \text{ (both stages)}$$

First stage:

$$f_{cl(in)} = \frac{1}{2\pi(6.9 \text{ k}\Omega)(10 \mu\text{F})} = \mathbf{2.31 \text{ Hz}}$$

$$R_{out} = 4.7 \text{ k}\Omega + 6.9 \text{ k}\Omega = 11.6 \text{ k}\Omega$$

$$f_{cl(out)} = \frac{1}{2\pi(11.6 \text{ k}\Omega)(10 \mu\text{F})} = \mathbf{1.37 \text{ Hz}}$$

$$R_{bypass} = 220 \Omega \parallel (112 \Omega + 22 \text{ k}\Omega \parallel 100 \text{ k}\Omega / 100) = 125 \Omega$$

$$f_{cl(bypass)} = \frac{1}{2\pi(125 \Omega)(100 \mu\text{F})} = \mathbf{12.7 \text{ Hz}}$$

Second stage:

$$f_{cl(in)} = \mathbf{1.37 \text{ Hz}}$$
 (same as  $f_{cl(out)}$  of first stage)

$$R_{out} = 4.7 \text{ k}\Omega + 10 \text{ k}\Omega = 14.7 \text{ k}\Omega$$

$$f_{cl(out)} = \frac{1}{2\pi(14.7 \text{ k}\Omega)(10 \mu\text{F})} = \mathbf{1.08 \text{ Hz}}$$

$$R_{bypass} = 220 \Omega \parallel (112 \Omega + 22 \text{ k}\Omega \parallel 100 \text{ k}\Omega \parallel 4.7 \text{ k}\Omega / 100) = 88.8 \Omega$$

$$f_{cl(bypass)} = \frac{1}{2\pi(88.8 \Omega)(100 \mu\text{F})} = \mathbf{17.9 \text{ Hz}}$$

First stage:

$$R_c = 4.7 \text{ k}\Omega \parallel 100 \text{ k}\Omega \parallel 22 \text{ k}\Omega \parallel (100)(100 \Omega + 11.7 \Omega) = 2.8 \text{ k}\Omega$$

$$A_{v1} = \frac{2.8 \text{ k}\Omega}{112 \Omega} = 25$$

$$C_{in(Miller)} = (25 + 1)4 \text{ pF} = 112 \text{ pF}$$

$$C_{in(Tot)} = 112 \text{ pF} + 8 \text{ pF} = 120 \text{ pF}$$

$$C_{out(Miller)} = \left( \frac{25 + 1}{25} \right) 4 \text{ pF} = 4.16 \text{ pF}$$

$$f_{cu(in)} = \frac{1}{2\pi(6.9 \text{ k}\Omega)(120 \text{ pF})} = \mathbf{192 \text{ kHz}}$$

$$f_{cu(out)} = \frac{1}{2\pi(2.8 \text{ k}\Omega)(4.16 \mu\text{F})} = \mathbf{13.7 \text{ MHz}}$$

## Chapter 10

---

Second stage:

$$R_c = 4.7 \text{ k}\Omega \parallel 10 \text{ k}\Omega = 3.2 \text{ k}\Omega$$

$$A_{v1} = \frac{3.2 \text{ k}\Omega}{112 \Omega} = 28.6$$

$$C_{in(Miller)} = (28.6 + 1)4 \text{ pF} = 119 \text{ pF}$$

$$C_{in(tot)} = 119 \text{ pF} + 8 \text{ pF} = 127 \text{ pF}$$

$$C_{out(Miller)} = \left( \frac{28.6 + 1}{28.6} \right) 4 \text{ pF} = 4.14 \text{ pF}$$

$$f_{cu(in)} = \frac{1}{2\pi(2.8 \text{ k}\Omega)(127 \text{ pF})} = 448 \text{ kHz}$$

$$f_{cu(out)} = \frac{1}{2\pi(3.2 \text{ k}\Omega)(4.14 \text{ pF})} = 12.0 \text{ MHz}$$

$$t_f = \frac{0.35}{17.9 \text{ Hz}} = 19.5 \text{ ms}$$

$$t_f = \frac{0.35}{192 \text{ kHz}} = 1.82 \mu\text{s}$$

### Data Sheet Problems

39.  $C_{in(tot)} = (25 + 1)4 \text{ pF} + 8 \text{ pF} = 112 \text{ pF}$

40.  $BW_{\min} = \frac{f_T}{A_{v(mid)}} = \frac{300 \text{ MHz}}{50} = 6 \text{ MHz}$

41.  $C_{gd} = C_{rss} = 1.3 \text{ pF}$   
 $C_{gs} = C_{iss} - C_{rss} = 5 \text{ pF} - 1.3 \text{ pF} = 3.7 \text{ pF}$   
 $C_{ds} = C_d - C_{rss} = 5 \text{ pF} - 1.3 \text{ pF} = 3.7 \text{ pF}$

### Advanced Problems

42. From Problem 12:  $r_e' = 7.81 \Omega$  and  $I_E = 3.2 \text{ mA}$   
 $V_C \cong 20 \text{ V} - (3.2 \text{ mA})(2.2 \text{ k}\Omega) = 13 \text{ V dc}$   
The maximum peak output signal can be approximately 6 V.  
The maximum allowable gain for the two stages is

$$A_{v(\max)} = \frac{6 \text{ V}}{1.414(10 \text{ mV})} = 424$$

For stage 1:

$$R_c = 2.2 \text{ k}\Omega \parallel 33 \text{ k}\Omega \parallel 4.7 \text{ k}\Omega \parallel (150)(7.81 \Omega) = 645 \Omega$$

$$A_{v1} = \frac{645 \Omega}{7.81 \Omega} = 82.6$$

For stage 2:

$$R_c = 2.2 \text{ k}\Omega \parallel 5.6 \text{ k}\Omega = 1.58 \text{ k}\Omega$$

$$A_{v1} = \frac{1.58 \text{ k}\Omega}{7.81 \Omega} = 202$$

$$A_{v(\text{tot})} = (82.6)(202) = 16,685$$

The amplifier will **not operate linearly** with a 10 mV rms input signal.

The gains of both stages can be reduced or the gain of the second stage only can be reduced. One approach is leave the gain of the first stage as is and bypass a portion of the emitter resistance in the second stage to achieve a gain of  $424/82.6 = 5.13$ .

$$A_v = \frac{R_c}{R_e + r'_e} = 5.13$$

$$R_e = \frac{R_c - 5.13r'_e}{5.13} = \frac{1.58 \text{ k}\Omega - 40.1 \Omega}{5.13} = 300 \Omega$$

**Modification:** Replace the 560  $\Omega$  emitter resistor in the second stage with an unbypassed 300  $\Omega$  resistor and a bypassed 260  $\Omega$  resistor (closest standard value is 270  $\Omega$ ).

43. From Problems 17, 18, and 21:

$$C_T = C_{gs} \parallel C_{in(\text{miller})} = 20.6 \text{ pF}$$

$$C_{out(\text{miller})} = 4 \text{ pF} \left( \frac{2.65 + 1}{2.65} \right) = 5.51 \text{ pF}$$

Stage 1:

$$f_{cl(\text{in})} = \frac{1}{2\pi R_{in} C_1} = \frac{1}{2\pi(9.52 \text{ M}\Omega)(0.005 \mu\text{F})} = 3.34 \text{ Hz}$$

$$f_{cl(\text{out})} = \frac{1}{2\pi(9.52 \text{ M}\Omega)(0.005 \mu\text{F})} = 3.34 \text{ Hz since } R_{in(2)} \gg 560 \Omega$$

$$f_{cu(\text{in})} = \frac{1}{2\pi(600 \Omega)(20.6 \text{ pF})} = 12.9 \text{ MHz}$$

$$f_{cu(\text{out})} = \frac{1}{2\pi(560 \Omega)(20.6 \text{ pF} + 5.51 \text{ pF})} = 10.5 \text{ MHz}$$

Stage 2:

$$f_{cl(\text{in})} = \frac{1}{2\pi R_{in} C_1} = \frac{1}{2\pi(9.52 \text{ M}\Omega)(0.005 \mu\text{F})} = 3.34 \text{ Hz}$$

$$f_{cl(\text{out})} = \frac{1}{2\pi(10.6 \text{ k}\Omega)(0.005 \mu\text{F})} = 3.01 \text{ kHz}$$

$$f_{cu(\text{in})} = \frac{1}{2\pi(560 \Omega)(20.6 \text{ pF} + 5.51 \text{ pF})} = 10.5 \text{ MHz}$$

$$f_{cu(\text{out})} = \frac{1}{2\pi(560 \Omega \parallel 10 \text{ k}\Omega)(5.51 \text{ pF})} = 54.5 \text{ MHz}$$

Overall:

$$f_{cl(\text{out})} = 3.01 \text{ kHz and } f_{cu(\text{in})} = 10.5 \text{ MHz}$$

$$BW \cong 10.5 \text{ MHz}$$

## Chapter 10

44.  $R_{in(1)} = 22 \text{ k}\Omega \parallel (100)(320 \Omega) = 13 \text{ k}\Omega$   
 $V_{B(1)} = \left( \frac{13 \text{ k}\Omega}{113 \text{ k}\Omega} \right) 12 \text{ V} = 1.38, V_{E(1)} = 0.684 \text{ V}$   
 $I_{E(1)} = \frac{0.684 \text{ V}}{320 \Omega} = 2.14 \text{ mA}, r'_e = 11.7 \Omega$   
 $R_{c(1)} = 4.7 \text{ k}\Omega \parallel 33 \text{ k}\Omega \parallel 22 \text{ k}\Omega \parallel (100)(100 \Omega) = 2.57 \text{ k}\Omega$   
 $A_{v(1)} = \frac{2.57 \text{ k}\Omega}{112 \Omega} = 23$   
 $R_{in(2)} = 22 \text{ k}\Omega \parallel (100)(1010 \Omega) = 18 \text{ k}\Omega$   
 $V_{B(2)} = \left( \frac{18 \text{ k}\Omega}{51 \text{ k}\Omega} \right) 12 \text{ V} = 4.42, V_{E(2)} = 3.54 \text{ V}$   
 $I_{E(2)} = \frac{3.54 \text{ V}}{1.01 \text{ k}\Omega} = 3.51 \text{ mA}, r'_e = 7.13 \Omega$   
 $R_{c(2)} = 3 \text{ k}\Omega \parallel 10 \text{ k}\Omega = 2.31 \text{ k}\Omega$   
 $A_{v(2)} = \frac{2.31 \text{ k}\Omega}{107.13 \Omega} = 24 \text{ maximum}$   
 $A_{v(2)} = \frac{2.31 \text{ k}\Omega}{101 \text{ k}\Omega + 7.13 \Omega} = 2.27 \text{ minimum}$

$A_{v(tot)} = (23)(24) = 554 \text{ maximum}$   
 $A_{v(tot)} = (23)(2.27) = 52.3 \text{ minimum}$   
 This is a bit high, so adjust  $R_{c(1)}$  to 3 k $\Omega$ , then  
 $A_{v(1)} = \frac{3 \text{ k}\Omega \parallel 22 \text{ k}\Omega \parallel 33 \text{ k}\Omega \parallel 101 \text{ k}\Omega}{112 \Omega} = 21.4$

Now,  
 $A_{v(tot)} = (21.3)(24) = \mathbf{513} \text{ maximum}$   
 $A_{v(tot)} = (21.3)(2.27) = \mathbf{48.5} \text{ minimum}$   
 Thus,  $A_v$  is within 3% of the desired specifications.

Frequency response for stage 1:

$R_{in} = 22 \text{ k}\Omega \parallel 100 \text{ k}\Omega \parallel 32 \text{ k}\Omega = 11.5 \text{ k}\Omega$   
 $f_{cl(in)} = \frac{1}{2\pi(11.5 \text{ k}\Omega)(10 \mu\text{F})} = 1.38 \text{ Hz}$   
 $R_{emitter} = 220 \Omega \parallel (100 \Omega + 11.7 \Omega + (22 \text{ k}\Omega \parallel 100 \text{ k}\Omega)100) = 125 \Omega$   
 $f_{cl(bypass)} = \frac{1}{2\pi(125 \Omega)(100 \mu\text{F})} = 12.7 \text{ Hz}$   
 $R_{out} = 3 \text{ k}\Omega + (33 \text{ k}\Omega \parallel 22 \text{ k}\Omega \parallel (100)(107 \Omega)) = 8.91 \text{ k}\Omega$   
 $f_{cl(out)} = \frac{1}{2\pi(8.91 \text{ k}\Omega)(10 \mu\text{F})} = 1.79 \text{ Hz}$

Frequency response for stage 2:

$$f_{cl(in)} = 1.79 \text{ Hz (same as } f_{cl(out)} \text{ for stage 1)}$$

$$R_{out} = 3 \text{ k}\Omega + 10 \text{ k}\Omega = 13 \text{ k}\Omega$$

$$f_{cl(out)} = \frac{1}{2\pi(13 \text{ k}\Omega)(10 \text{ }\mu\text{F})} = 1.22 \text{ Hz}$$

This means that  $C_{E(2)}$  is the frequency limiting capacitance.

$$R_{emitter} = 910 \text{ }\Omega \parallel (100 \text{ }\Omega + 7 \text{ }\Omega + (22 \text{ k}\Omega \parallel 33 \text{ k}\Omega \parallel 3 \text{ k}\Omega) / 100) = 115 \text{ }\Omega$$

For  $f'_{cl} = 1 \text{ kHz}$ :

$$C_{E(2)} = \frac{1}{2\pi(115 \text{ }\Omega)(1 \text{ kHz})} = 1.38 \text{ }\mu\text{F}$$

1.5  $\mu\text{F}$  is the closest standard value and gives

$$f_{cl(bypass)} = \frac{1}{2\pi(115 \text{ }\Omega)(1.5 \text{ }\mu\text{F})} = 922 \text{ Hz}$$

This value can be moved closer to 1 kHz by using additional parallel bypass capacitors in stage 2 to fine-tune the response.

## EWB/Multisim Troubleshooting Problems

The solutions showing instrument connections for Problems 45 through 48 are available in the Solutions folder for Chapter 10 on the CD-ROM provided with the textbook. The solutions may be accessed using the password *EDSFLOYD*. The faults in the circuit files may be accessed using the password *book* (all lowercase).

45.  $R_C$  open
46. Output capacitor open
47.  $R_2$  open
48. Drain-source shorted

# Chapter 11

## Thyristors and Other Devices

---

### Section 11-1 The Basic 4-Layer Device

1.  $V_A = V_{BE} - V_{CE(sat)} = 0.7 \text{ V} + 0.2 \text{ V} = 0.9 \text{ V}$   
 $V_{R_s} = V_{BIAS} - V_A = 25 \text{ V} - 0.9 \text{ V} = 24.1 \text{ V}$   
 $I_A = \frac{V_{R_s}}{R_s} = \frac{24.1 \text{ V}}{1.0 \text{ k}\Omega} = 24.1 \text{ mA}$

2. (a)  $R_{AK} = \frac{V_{AK}}{I_A} = \frac{15 \text{ V}}{1 \mu\text{A}} = 15 \text{ M}\Omega$   
(b) From 15 V to 50 V for an increase of 35 V.

### Section 11-2 The Silicon-Controlled Rectifier (SCR)

3. See Section 11-2 in the textbook.  
4. Neglecting the SCR voltage drop,

$$R_{max} = \frac{30 \text{ V}}{10 \text{ mA}} = 3 \text{ k}\Omega$$

### Section 11-3 SCR Applications

5. Add a transistor to provide inversion of the negative half-cycle in order to obtain a positive gate trigger.  
6.  $D_1$  and  $D_2$  are full-wave rectifier diodes.  
7. See Figure 11-1.

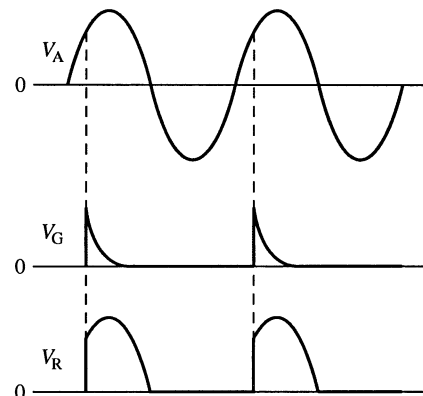
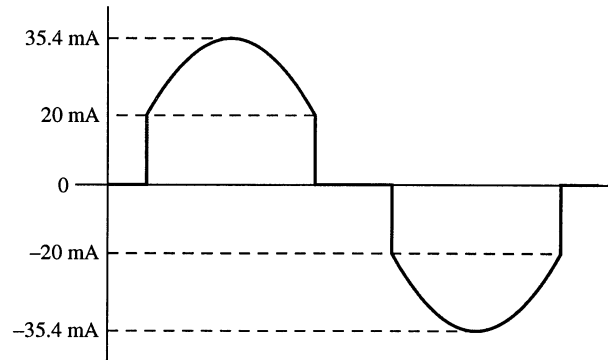

Figure 11-1

**Section 11-4 The Diac and Triac**

8.  $V_{in(p)} = 1.414V_{in(rms)} = 1.414(25 \text{ V}) = 35.4 \text{ V}$   
 $I_p = \frac{V_{in(p)}}{1.0 \text{ k}\Omega} = \frac{35.35 \text{ V}}{1.0 \text{ k}\Omega} = 35.4 \text{ mA}$   
 Current at breakover =  $\frac{20 \text{ V}}{1.0 \text{ k}\Omega} = 20 \text{ mA}$   
 See Figure 11-2.



**Figure 11-2**

9.  $I_p = \frac{15 \text{ V}}{4.7 \text{ k}\Omega} = 3.19 \text{ mA}$   
 See Figure 11-3.

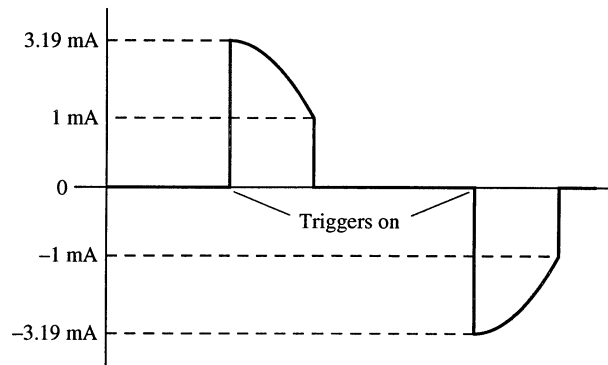

**Figure 11-3**

**Section 11-5 The Silicon-Controlled Switch (SCS)**

10. See Section 11-5 in the text.  
 11. Anode, cathode, anode gate, and cathode gate

# Chapter 11

## Section 11-6 The Unijunction Transistor (UJT)

$$12. \quad \eta = \frac{r'_{B1}}{r'_{B1} + r'_{B2}} = \frac{2.5 \text{ k}\Omega}{2.5 \text{ k}\Omega + 4 \text{ k}\Omega} = 0.385$$

$$13. \quad V_p = \eta V_{BB} + V_{pn} = 0.385(15 \text{ V}) + 0.7 \text{ V} = 6.48 \text{ V}$$

$$14. \quad \frac{V_{BB} - V_v}{I_v} < R_1 < \frac{V_{BB} - V_p}{I_p}$$

$$\frac{12 \text{ V} - 0.8 \text{ V}}{15 \text{ mA}} < R_1 < \frac{12 \text{ V} - 10 \text{ V}}{10 \mu\text{A}}$$

$$747 \Omega < R_1 < 200 \text{ k}\Omega$$

## Section 11-7 The Programmable UJT (PUT)

$$15. \quad (a) \quad V_A = \left( \frac{R_3}{R_2 + R_3} \right) V_B + 0.7 \text{ V} = \left( \frac{10 \text{ k}\Omega}{22 \text{ k}\Omega} \right) 20 \text{ V} + 0.7 \text{ V} = 9.79 \text{ V}$$

$$(b) \quad V_A = \left( \frac{R_3}{R_2 + R_3} \right) V_B + 0.7 \text{ V} = \left( \frac{47 \text{ k}\Omega}{94 \text{ k}\Omega} \right) 9 \text{ V} + 0.7 \text{ V} = 5.2 \text{ V}$$

16. (a) From Problem 15(a),  $V_A = 9.79 \text{ V}$  at turn on.

$$I = \frac{9.79 \text{ V}}{470 \Omega} = 20.8 \text{ mA at turn on}$$

$$I_p = \frac{10 \text{ V}}{470 \Omega} = 21.3 \text{ mA}$$

See Figure 11-4.

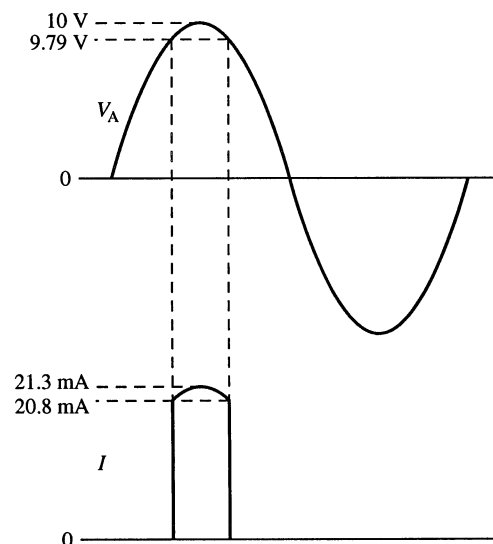

Figure 11-4



(b) From Problem 15(b),  $V_A = 5.2 \text{ V}$  at turn on.

$$I = \frac{5.2 \text{ V}}{330 \Omega} = 15.8 \text{ mA at turn on}$$

$$I_p = \frac{10 \text{ V}}{330 \Omega} = 30.3 \text{ mA}$$

See Figure 11-5.

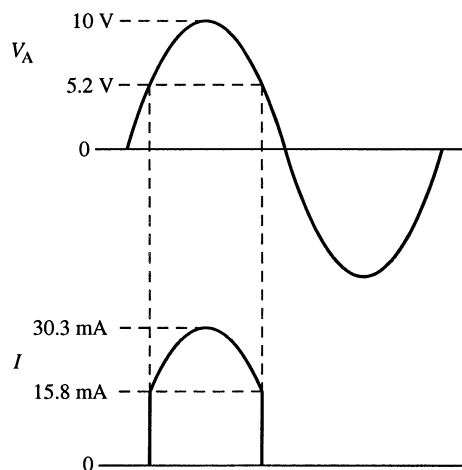
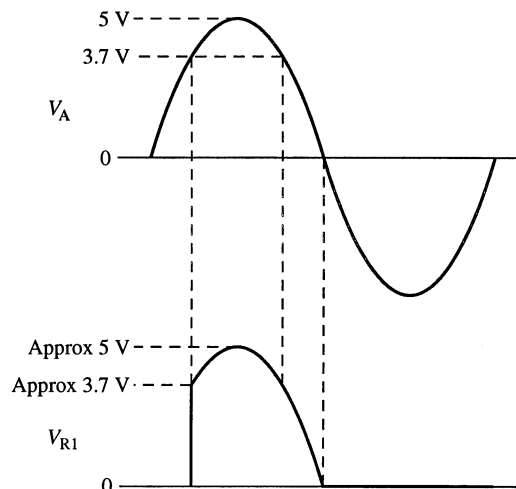

**Figure 11-5**

17. 
$$V_A = \left( \frac{R_3}{R_2 + R_3} \right) 6 \text{ V} + 0.7 \text{ V} = \left( \frac{10 \text{ k}\Omega}{20 \text{ k}\Omega} \right) 6 \text{ V} + 0.7 \text{ V} = 3.7 \text{ V at turn on}$$

$V_{R1} \cong V_A = 3.7 \text{ V}$  at turn on.

See Figure 11-6.



**Figure 11-6**

# Chapter 11

## Section 11-8 The Phototransistor

18.  $I_C = \beta_{DC} I_\lambda = (200)(100 \mu\text{A}) = 20 \text{ mA}$
19. (a)  $V_{OUT} = 12 \text{ V}$   
(b)  $V_{OUT} = 0 \text{ V}$
20.  $I_{\lambda 1} = (50 \text{ lm/m}^2)(1 \mu\text{A/lm/m}^2) = 50 \mu\text{A}$   
 $I_E = \beta_{DC1} \beta_{DC2} I_{\lambda 1} = (100)(150)(50 \mu\text{A}) = 750 \text{ mA}$

## Section 11-9 The Light-Activated SCR (LASCR)

21. When the switch is closed, the battery  $V_2$  causes illumination of the lamp. The light energy causes the LASCR to conduct and thus energize the relay. When the relay is energized, the contacts close and 115 V ac are applied to the motor.
22. See Figure 11-7.

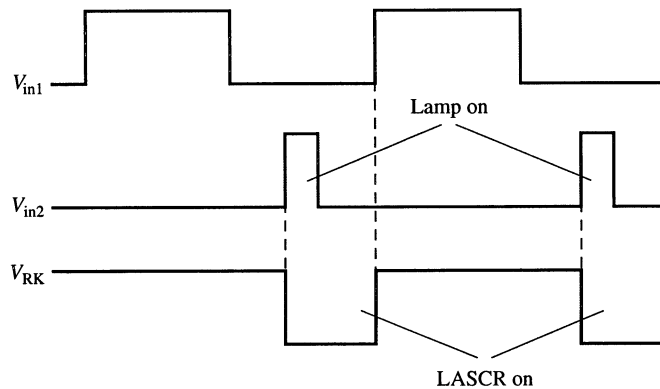

Figure 11-7

## Section 11-10 Optical Couplers

23.  $I_{out} = (0.30)(100 \text{ mA}) = 30 \text{ mA}$
24.  $\frac{I_{OUT}}{I_{IN}} = 0.6$   
 $I_{IN} = \frac{I_{OUT}}{0.6} = \frac{10 \text{ mA}}{0.6} = 16.7 \text{ mA}$

## System Application Problems

25. The motor runs fastest at 0 V for the motor speed control circuit.
26. If the rheostat resistance decreases, the SCR turns on **earlier** in the ac cycle.
27. As the PUT gate voltage increases in the circuit, the PUT triggers on later in the ac cycle causing the SCR to fire later in the cycle, conduct for a shorter time, and decrease the power to the motor.

## Advanced Problems

28.  $D_1$ : 15 V zener (1N4744)  
 $R_1$ : 100  $\Omega$ , 1 W  
 $R_2$ : 100  $\Omega$ , 1 W  
 $Q_1$ : Any SCR with a 1 A minimum rating (1.5 A would be better)  
 $R_3$ : 150  $\Omega$ , 1 W
29. See Figure 11-8.

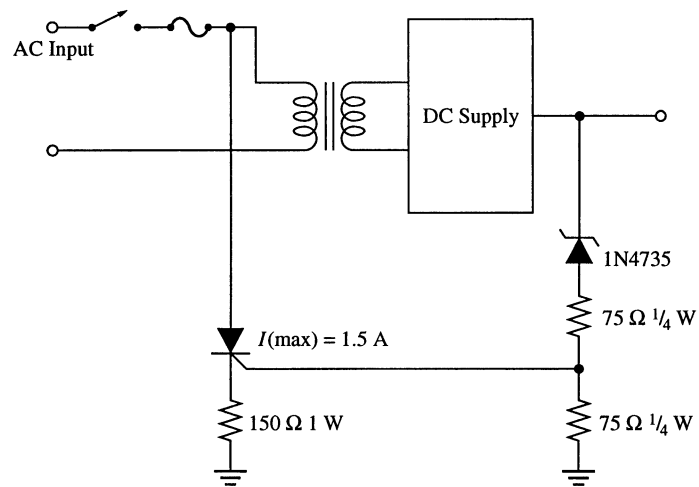

**Figure 11-8**

30.  $V_p = \eta V_{BB} + V_{pn} = (0.75)(12 \text{ V}) + 0.7 \text{ V} = 9.7 \text{ V}$   
 $I_v = 10 \text{ mA}$  and  $I_p = 20 \mu\text{A}$   
 $R_1 < \frac{12 \text{ V} - 9.7 \text{ V}}{20 \mu\text{A}} = 115 \text{ k}\Omega$   
 $R_1 > \frac{12 \text{ V} - 1 \text{ V}}{10 \text{ mA}} = 1.1 \text{ k}\Omega$   
 Select  $R_1 = 51 \text{ k}\Omega$  as an intermediate value.  
 During the charging cycle:  
 $V(t) = V_F - (V_F - V_0)e^{-t/R_1C}$   
 $9.7 \text{ V} = 12 \text{ V} - (12 \text{ V} - 1 \text{ V})e^{-t_1/R_1C}$   
 $-\frac{t_1}{R_1C} = \ln\left(\frac{2.3 \text{ V}}{11 \text{ V}}\right)$   
 $t_1 = -R_1C \ln\left(\frac{2.3 \text{ V}}{11 \text{ V}}\right) = 1.56R_1C = 79.8 \times 10^3 C$

## Chapter 11

During the discharging cycle (assuming  $R_2 \gg R_{B1}$ ):

$$V(t) = V_F - (V_F - V_0)e^{-t_2/R_2C}$$

$$1 \text{ V} = 0 \text{ V} - (0 \text{ V} - 9.3 \text{ V})e^{-t_2/R_2C}$$

$$-\frac{t_2}{R_2C} = \ln\left(\frac{1 \text{ V}}{9.3 \text{ V}}\right)$$

$$t_2 = -R_2C \ln\left(\frac{1 \text{ V}}{9.3 \text{ V}}\right) = 2.23R_2C$$

Let  $R_2 = 100 \text{ k}\Omega$ , so  $t_2 = 223 \times 10^3 C$ .

Since  $f = 2.5 \text{ kHz}$ ,  $T = 400 \mu\text{s}$

$$T = t_1 + t_2 = 79.8 \times 10^3 C + 223 \times 10^3 C = 303 \times 10^3 C = 400 \mu\text{s}$$

$$C = \frac{400 \mu\text{s}}{303 \times 10^3} = 0.0013 \mu\text{F}$$

See Figure 11-9.

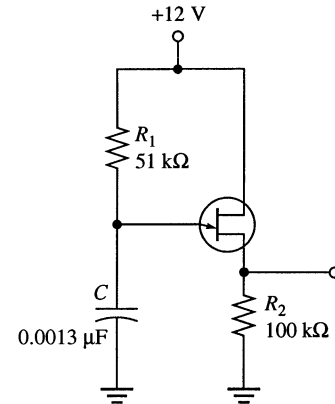

Figure 11-9

### EWB/Multisim Troubleshooting Problems

The solutions showing instrument connections for Problems 31 through 33 are available in the Solutions folder for Chapter 11 on the CD-ROM provided with the textbook. The solutions may be accessed using the password *ED5FLOYD*. The faults in the circuit files may be accessed using the password *book* (all lowercase).

31. Shockley diode shorted (EWB only)
32. Gate-cathode open
33.  $R_1$  shorted

# Chapter 12

## Operational Amplifiers

---

### Section 12-1 Introduction to Operational Amplifiers

1. *Practical op-amp*: High open-loop gain, high input impedance, low output impedance, and high CMRR.  
*Ideal op-amp*: Infinite open-loop gain, infinite input impedance, zero output impedance, and infinite CMRR.
2. Op amp 2 is more desirable because it has a higher input impedance, a lower output impedance, and a higher open-loop gain.

### Section 12-2 Op-Amp Input Modes and Parameters

3. (a) Single-ended input  
(b) Differential input  
(c) Common-mode
4.  $\text{CMRR}(\text{dB}) = 20 \log(250,000) = 108 \text{ dB}$
5.  $\text{CMRR}(\text{dB}) = 20 \log\left(\frac{A_{ol}}{A_{cm}}\right) = 20 \log\left(\frac{175,000}{0.18}\right) = 120 \text{ dB}$
6.  $\text{CMRR} = \frac{A_{ol}}{A_{cm}}$   
 $A_{cm} = \frac{A_{ol}}{\text{CMRR}} = \frac{90,000}{300,000} = 0.3$
7.  $I_{\text{BIAS}} = \frac{8.3 \mu\text{A} - 7.9 \mu\text{A}}{2} = 8.1 \mu\text{A}$
8. Input bias current is the average of the two input currents. Input offset current is the difference between the two input currents.  
 $I_{\text{OS}} = |8.3 \mu\text{A} - 7.9 \mu\text{A}| = 400 \text{ nA}$
9.  $\text{Slew rate} = \frac{24 \text{ V}}{15 \mu\text{s}} = 1.6 \text{ V}/\mu\text{s}$
10.  $\Delta t = \frac{\Delta V_{out}}{\text{slew rate}} = \frac{20 \text{ V}}{0.5 \text{ V}/\mu\text{s}} = 40 \mu\text{s}$

## Chapter 12

### Section 12-4 Op-Amps with Negative Feedback

11. (a) Voltage-follower  
(b) Noninverting  
(c) Inverting

12. 
$$B = \frac{R_i}{R_i + R_f} = \frac{1.0 \text{ k}\Omega}{101 \text{ k}\Omega} = 9.90 \times 10^{-3}$$
$$V_f = BV_{out} = (9.90 \times 10^{-3})5 \text{ V} = 0.0495 \text{ V} = 49.5 \text{ mV}$$

13. (a) 
$$A_{cl(NI)} = \frac{1}{B} = \frac{1}{1.5 \text{ k}\Omega / 561.5 \text{ k}\Omega} = 374$$
  
(b) 
$$V_{out} = A_{cl(NI)}V_{in} = (374)(10 \text{ mV}) = 3.74 \text{ V rms}$$
  
(c) 
$$V_f = \left( \frac{1.5 \text{ k}\Omega}{561.5 \text{ k}\Omega} \right) 3.74 \text{ V} = 9.99 \text{ mV rms}$$

14. (a) 
$$A_{cl(NI)} = \frac{1}{B} = \frac{1}{4.7 \text{ k}\Omega / 51.7 \text{ k}\Omega} = 11$$
  
(b) 
$$A_{cl(NI)} = \frac{1}{B} = \frac{1}{10 \text{ k}\Omega / 1.01 \text{ M}\Omega} = 101$$
  
(c) 
$$A_{cl(NI)} = \frac{1}{B} = \frac{1}{4.7 \text{ k}\Omega / 224.7 \text{ k}\Omega} = 47.8$$
  
(d) 
$$A_{cl(NI)} = \frac{1}{B} = \frac{1}{1.0 \text{ k}\Omega / 23 \text{ k}\Omega} = 23$$

15. (a) 
$$1 + \frac{R_f}{R_i} = A_{cl(NI)}$$
$$R_f = R_i(A_{cl(NI)} - 1) = 1.0 \text{ k}\Omega(50 - 1) = 49 \text{ k}\Omega$$
  
(b) 
$$\frac{R_f}{R_i} = A_{cl(I)}$$
$$R_f = -R_i(A_{cl(I)}) = -10 \text{ k}\Omega(-300) = 3 \text{ M}\Omega$$
  
(c) 
$$R_f = R_i(A_{cl(NI)} - 1) = 12 \text{ k}\Omega(7) = 84 \text{ k}\Omega$$
  
(d) 
$$R_f = -R_i(A_{cl(I)}) = -2.2 \text{ k}\Omega(-75) = 165 \text{ k}\Omega$$

16. (a) 
$$A_{cl(VF)} = 1$$
  
(b) 
$$A_{cl(I)} = -\left( \frac{R_f}{R_i} \right) = -\left( \frac{100 \text{ k}\Omega}{100 \text{ k}\Omega} \right) = -1$$
  
(c) 
$$A_{cl(NI)} = \frac{1}{\left( \frac{R_i}{R_i + R_f} \right)} = \frac{1}{\left( \frac{47 \text{ k}\Omega}{47 \text{ k}\Omega + 1.0 \text{ M}\Omega} \right)} = 22$$
  
(d) 
$$A_{cl(I)} = -\left( \frac{R_f}{R_i} \right) = -\left( \frac{330 \text{ k}\Omega}{33 \text{ k}\Omega} \right) = -10$$

17. (a)  $V_{out} \cong V_{in} = 10 \text{ mV}$ , in phase  
 (b)  $V_{out} = A_{cl}V_{in} = -\left(\frac{R_f}{R_i}\right)V_{in} = -(1)(10 \text{ mV}) = -10 \text{ mV}$ , 180° out of phase  
 (c)  $V_{out} = \left(\frac{1}{\left(\frac{R_i}{R_i + R_f}\right)}\right)V_{in} = \left(\frac{1}{\left(\frac{47 \text{ k}\Omega}{1047 \text{ k}\Omega}\right)}\right)10 \text{ mV} = 223 \text{ mV}$ , in phase  
 (d)  $V_{out} = -\left(\frac{R_f}{R_i}\right)V_{in} = -\left(\frac{330 \text{ k}\Omega}{33 \text{ k}\Omega}\right)10 \text{ mV} = -100 \text{ mV}$ , 180° out of phase
18. (a)  $I_{in} = \frac{V_{in}}{R_{in}} = \frac{1 \text{ V}}{2.2 \text{ k}\Omega} = 455 \mu\text{A}$   
 (b)  $I_f \cong I_{in} = 455 \mu\text{A}$   
 (c)  $V_{out} = -I_f R_f = -(455 \mu\text{A})(22 \text{ k}\Omega) = -10 \text{ V}$   
 (d)  $A_{cl(1)} = -\left(\frac{R_f}{R_i}\right) = -\left(\frac{22 \text{ k}\Omega}{2.2 \text{ k}\Omega}\right) = -10$

**Section 12-5 Effects of Negative Feedback on Op-Amp Impedances**

19. (a)  $B = \frac{2.7 \text{ k}\Omega}{562.5 \text{ k}\Omega} = 0.0048$   
 $Z_{in(NI)} = (1 + A_{ol})Z_{in} = [1 + (175,000)(0.0048)]10 \text{ M}\Omega = 8.41 \text{ G}\Omega$   
 $Z_{out(NI)} = \frac{Z_{out}}{1 + A_{ol}B} = \frac{75 \Omega}{1 + (175,000)(0.0048)} = 89.2 \text{ m}\Omega$
- (b)  $B = \frac{1.5 \text{ k}\Omega}{48.5 \text{ k}\Omega} = 0.031$   
 $Z_{in(NI)} = (1 + A_{ol})Z_{in} = [1 + (200,000)(0.031)]1 \text{ M}\Omega = 6.20 \text{ G}\Omega$   
 $Z_{out(NI)} = \frac{Z_{out}}{1 + A_{ol}B} = \frac{25 \Omega}{1 + (200,000)(0.031)} = 4.04 \text{ m}\Omega$
- (c)  $B = \frac{56 \text{ k}\Omega}{1.056 \text{ M}\Omega} = 0.053$   
 $Z_{in(NI)} = (1 + A_{ol})Z_{in} = [1 + (50,000)(0.053)]2 \text{ M}\Omega = 5.30 \text{ G}\Omega$   
 $Z_{out(NI)} = \frac{Z_{out}}{1 + A_{ol}B} = \frac{50 \Omega}{1 + (50,000)(0.053)} = 19.0 \text{ m}\Omega$

## Chapter 12

20. (a)  $Z_{in(VF)} = (1 + A_{ol})Z_{in} = (1 + 220,000)6 \text{ M}\Omega = 1.32 \times 10^{12} \Omega = 1.32 \text{ T}\Omega$

$$Z_{out(VF)} = \frac{Z_{out}}{1 + A_{ol}} = \frac{100 \Omega}{1 + 220,000} = 455 \mu\Omega$$

(b)  $Z_{in(VF)} = (1 + A_{ol})Z_{in} = (1 + 100,000)5 \text{ M}\Omega = 5 \times 10^{11} \Omega = 500 \text{ G}\Omega$

$$Z_{out(VF)} = \frac{Z_{out}}{1 + A_{ol}} = \frac{60 \Omega}{1 + 100,000} = 600 \mu\Omega$$

(c)  $Z_{in(VF)} = (1 + A_{ol})Z_{in} = (1 + 50,000)800 \text{ k}\Omega = 40 \text{ G}\Omega$

$$Z_{out(VF)} = \frac{Z_{out}}{1 + A_{ol}} = \frac{75 \Omega}{1 + 500,000} = 1.5 \text{ m}\Omega$$

21. (a)  $Z_{in(I)} \cong R_i = 10 \text{ k}\Omega$

$$B = \frac{R_i}{R_i + R_f} = \frac{10 \text{ k}\Omega}{160 \text{ k}\Omega} = 0.0625$$

$$Z_{out(I)} = \frac{Z_{out}}{1 + A_{ol}B} = \frac{40 \Omega}{1 + (125,000)(0.0625)} = 5.12 \text{ m}\Omega$$

(b)  $Z_{in(I)} \cong R_i = 100 \text{ k}\Omega$

$$B = \frac{100 \text{ k}\Omega}{1.1 \text{ M}\Omega} = 0.090$$

$$Z_{out(I)} = \frac{Z_{out}}{1 + A_{ol}B} = \frac{50 \Omega}{1 + (75,000)(0.90)} = 7.41 \text{ m}\Omega$$

(c)  $Z_{in(I)} \cong R_i = 470 \Omega$

$$B = \frac{470 \Omega}{10,470 \Omega} = 0.045$$

$$Z_{out(I)} = \frac{Z_{out}}{1 + A_{ol}B} = \frac{70 \Omega}{1 + (250,000)(0.045)} = 6.22 \text{ m}\Omega$$

### Section 12-6 Bias Current and Offset Voltage Compensation

22. (a)  $R_{comp} = R_{in} = 75 \Omega$  placed in the feedback path.

$$I_{OS} = |42 \mu\text{A} - 40 \mu\text{A}| = 2 \mu\text{A}$$

(b)  $V_{OUT(\text{error})} = A_v I_{OS} R_{in} = (1)(2 \mu\text{A})(75 \Omega) = 150 \mu\text{V}$

23. (a)  $R_c = R_i \parallel R_f = 2.7 \text{ k}\Omega \parallel 560 \text{ k}\Omega = 2.69 \text{ k}\Omega$

(b)  $R_c = R_i \parallel R_f = 1.5 \text{ k}\Omega \parallel 47 \text{ k}\Omega = 1.45 \text{ k}\Omega$

(c)  $R_c = R_i \parallel R_f = 56 \text{ k}\Omega \parallel 1.0 \text{ M}\Omega = 53 \text{ k}\Omega$

See Figure 12-1.

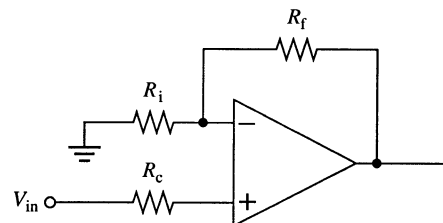

Figure 12-1



24.  $V_{\text{OUT(error)}} = A_v V_{\text{IO}} = (1)(2 \text{ nV}) = \mathbf{2 \text{ nV}}$

25.  $V_{\text{OUT(error)}} = (1 + A_{ol})V_{\text{IO}}$   
 $V_{\text{IO}} = \frac{V_{\text{OUT(error)}}}{A_{ol}} = \frac{35 \text{ mV}}{200,000} = \mathbf{175 \text{ nV}}$

**Section 12-7 Open-Loop Response**

26.  $A_{cl} = 120 \text{ dB} - 50 \text{ dB} = \mathbf{70 \text{ dB}}$

27. The gain is ideally **175,000** at 200 Hz. The midrange dB gain is  
 $20 \log(175,000) = 105 \text{ dB}$   
 The actual gain at 200 Hz is  
 $A_v(\text{dB}) = 105 \text{ dB} - 3 \text{ dB} = 102 \text{ dB}$   
 $A_v = \log^{-1}\left(\frac{102}{20}\right) = \mathbf{125,892}$   
 $BW_{ol} = \mathbf{200 \text{ Hz}}$

28.  $\frac{f_c}{f} = \frac{X_C}{R}$   
 $X_C = \frac{Rf_c}{f} = \frac{(1.0 \text{ k}\Omega)(5 \text{ kHz})}{3 \text{ kHz}} = \mathbf{1.67 \text{ k}\Omega}$

29. (a)  $\frac{V_{out}}{V_{in}} = \frac{1}{\sqrt{1 + \left(\frac{f}{f_c}\right)^2}} = \frac{1}{\sqrt{1 + \left(\frac{1 \text{ kHz}}{12 \text{ kHz}}\right)^2}} = \mathbf{0.997}$

(b)  $\frac{V_{out}}{V_{in}} = \frac{1}{\sqrt{1 + \left(\frac{f}{f_c}\right)^2}} = \frac{1}{\sqrt{1 + \left(\frac{5 \text{ kHz}}{12 \text{ kHz}}\right)^2}} = \mathbf{0.923}$

(c)  $\frac{V_{out}}{V_{in}} = \frac{1}{\sqrt{1 + \left(\frac{f}{f_c}\right)^2}} = \frac{1}{\sqrt{1 + \left(\frac{12 \text{ kHz}}{12 \text{ kHz}}\right)^2}} = \mathbf{0.707}$

(d)  $\frac{V_{out}}{V_{in}} = \frac{1}{\sqrt{1 + \left(\frac{f}{f_c}\right)^2}} = \frac{1}{\sqrt{1 + \left(\frac{20 \text{ kHz}}{12 \text{ kHz}}\right)^2}} = \mathbf{0.515}$

(e)  $\frac{V_{out}}{V_{in}} = \frac{1}{\sqrt{1 + \left(\frac{f}{f_c}\right)^2}} = \frac{1}{\sqrt{1 + \left(\frac{100 \text{ kHz}}{12 \text{ kHz}}\right)^2}} = \mathbf{0.119}$

## Chapter 12

$$30. \quad (a) \quad A_{ol} = \frac{A_{ol(mid)}}{\sqrt{1 + \left(\frac{f}{f_{c(ol)}}\right)^2}} = \frac{80,000}{\sqrt{1 + \left(\frac{100 \text{ Hz}}{1 \text{ kHz}}\right)^2}} = 79,603$$

$$(b) \quad A_{ol} = \frac{A_{ol(mid)}}{\sqrt{1 + \left(\frac{f}{f_{c(ol)}}\right)^2}} = \frac{80,000}{\sqrt{1 + \left(\frac{1 \text{ kHz}}{1 \text{ kHz}}\right)^2}} = 56,569$$

$$(c) \quad A_{ol} = \frac{A_{ol(mid)}}{\sqrt{1 + \left(\frac{f}{f_{c(ol)}}\right)^2}} = \frac{80,000}{\sqrt{1 + \left(\frac{10 \text{ kHz}}{1 \text{ kHz}}\right)^2}} = 7960$$

$$(d) \quad A_{ol} = \frac{A_{ol(mid)}}{\sqrt{1 + \left(\frac{f}{f_{c(ol)}}\right)^2}} = \frac{80,000}{\sqrt{1 + \left(\frac{1 \text{ MHz}}{1 \text{ kHz}}\right)^2}} = 80$$

$$31. \quad (a) \quad f_c = \frac{1}{2\pi RC} = \frac{1}{2\pi(10 \text{ k}\Omega)(0.01 \mu\text{F})} = 1.59 \text{ kHz}; \quad \theta = \tan^{-1}\left(\frac{f}{f_c}\right) = \tan^{-1}\left(\frac{2 \text{ kHz}}{1.59 \text{ kHz}}\right) = -51.5^\circ$$

$$(b) \quad f_c = \frac{1}{2\pi RC} = \frac{1}{2\pi(1.0 \text{ k}\Omega)(0.01 \mu\text{F})} = 15.9 \text{ kHz}; \quad \theta = \tan^{-1}\left(\frac{f}{f_c}\right) = \tan^{-1}\left(\frac{2 \text{ kHz}}{15.9 \text{ kHz}}\right) = -7.17^\circ$$

$$(c) \quad f_c = \frac{1}{2\pi RC} = \frac{1}{2\pi(100 \text{ k}\Omega)(0.01 \mu\text{F})} = 159 \text{ Hz}; \quad \theta = \tan^{-1}\left(\frac{f}{f_c}\right) = \tan^{-1}\left(\frac{2 \text{ kHz}}{159 \text{ Hz}}\right) = -85.5^\circ$$

$$32. \quad (a) \quad \theta = \tan^{-1}\left(\frac{f}{f_c}\right) = \tan^{-1}\left(\frac{100 \text{ Hz}}{8.5 \text{ kHz}}\right) = -0.674^\circ$$

$$(b) \quad \theta = \tan^{-1}\left(\frac{f}{f_c}\right) = \tan^{-1}\left(\frac{400 \text{ Hz}}{8.5 \text{ kHz}}\right) = -2.69^\circ$$

$$(c) \quad \theta = \tan^{-1}\left(\frac{f}{f_c}\right) = \tan^{-1}\left(\frac{850 \text{ Hz}}{8.5 \text{ kHz}}\right) = -5.71^\circ$$

$$(d) \quad \theta = \tan^{-1}\left(\frac{f}{f_c}\right) = \tan^{-1}\left(\frac{8.5 \text{ kHz}}{8.5 \text{ kHz}}\right) = -45.0^\circ$$

$$(e) \quad \theta = \tan^{-1}\left(\frac{f}{f_c}\right) = \tan^{-1}\left(\frac{25 \text{ kHz}}{8.5 \text{ kHz}}\right) = -71.2^\circ$$

$$(f) \quad \theta = \tan^{-1}\left(\frac{f}{f_c}\right) = \tan^{-1}\left(\frac{85 \text{ kHz}}{8.5 \text{ kHz}}\right) = -84.3^\circ$$

See Figure 12-2.

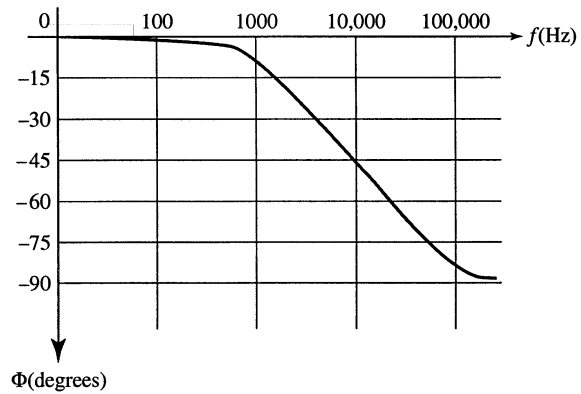

Figure 12-2

33. (a)  $A_{ol(mid)} = 30 \text{ dB} + 40 \text{ dB} + 20 \text{ dB} = \mathbf{90 \text{ dB}}$

(b)  $\theta_1 = -\tan^{-1}\left(\frac{f}{f_c}\right) = -\tan^{-1}\left(\frac{10 \text{ kHz}}{600 \text{ Hz}}\right) = -86.6^\circ$

$\theta_2 = -\tan^{-1}\left(\frac{f}{f_c}\right) = -\tan^{-1}\left(\frac{10 \text{ kHz}}{50 \text{ kHz}}\right) = -11.3^\circ$

$\theta_3 = -\tan^{-1}\left(\frac{f}{f_c}\right) = -\tan^{-1}\left(\frac{10 \text{ kHz}}{200 \text{ kHz}}\right) = -2.86^\circ$

$\theta_{tot} = -86.6^\circ - 11.3^\circ - 2.86^\circ - 180^\circ = \mathbf{-281^\circ}$

34. (a) 0 dB/decade  
 (b) -20 dB/decade  
 (c) -40 dB/decade  
 (d) -60 dB/decade

**Section 12-8 Closed-Loop Response**

35. (a)  $A_{cl(I)} = -\left(\frac{R_f}{R_i}\right) = -\left(\frac{68 \text{ k}\Omega}{2.2 \text{ k}\Omega}\right) = -30.9; \quad A_{cl(I)}(\text{dB}) = 20 \log(30.9) = \mathbf{29.8 \text{ dB}}$

(b)  $A_{cl(NI)} = \frac{1}{B} = \frac{1}{15 \text{ k}\Omega / 235 \text{ k}\Omega} = 15.7; \quad A_{cl(NI)}(\text{dB}) = 20 \log(15.7) = \mathbf{23.9 \text{ dB}}$

(c)  $A_{cl(VF)} = 1; \quad A_{cl(VF)}(\text{dB}) = 20 \log(1) = \mathbf{0 \text{ dB}}$   
 These are all closed-loop gains.

36.  $BW_{cl} = BW_{ol}(1 + BA_{ol(mid)}) = 1500 \text{ Hz}[1 + (0.015)(180,000)] = \mathbf{4.05 \text{ MHz}}$

## Chapter 12

37.  $A_{ol}(\text{dB}) = 89 \text{ dB}$   
 $A_{ol} = 28,184$   
 $A_{cl}f_{c(cl)} = A_{ol}f_{c(ol)}$   
 $A_{cl} = \frac{A_{ol}f_{c(ol)}}{f_{c(cl)}} = \frac{(28,184)(750 \text{ Hz})}{5.5 \text{ kHz}} = 3843$   
 $A_{cl}(\text{dB}) = 20 \log(3843) = \mathbf{71.7 \text{ dB}}$
38.  $A_{cl} = \frac{A_{ol}f_{c(ol)}}{f_{c(cl)}} = \frac{(28,184)(750 \text{ Hz})}{5.5 \text{ kHz}} = 3843$   
 Unity-gain bandwidth =  $A_{cl}f_{c(cl)} = (3843)(5.5 \text{ kHz}) = \mathbf{21.1 \text{ MHz}}$
39. (a)  $A_{cl(\text{VF})} = 1$   
 $BW = f_{c(cl)} = \frac{\text{Unity-gain } BW}{A_{cl}} = \frac{28 \text{ MHz}}{1} = \mathbf{2.8 \text{ MHz}}$
- (b)  $A_{cl(\text{I})} = -\frac{100 \text{ k}\Omega}{2.2 \text{ k}\Omega} = \mathbf{-45.5}$   
 $BW = \frac{2.8 \text{ MHz}}{45.5} = \mathbf{61.6 \text{ kHz}}$
- (c)  $A_{cl(\text{NI})} = 1 + \frac{12 \text{ k}\Omega}{1.0 \text{ k}\Omega} = \mathbf{13}$   
 $BW = \frac{2.8 \text{ MHz}}{13} = \mathbf{215 \text{ kHz}}$
- (d)  $A_{cl(\text{I})} = -\frac{1 \text{ M}\Omega}{5.6 \text{ k}\Omega} = \mathbf{-179}$   
 $BW = \frac{2.8 \text{ MHz}}{179} = \mathbf{15.7 \text{ kHz}}$
40. (a)  $A_{cl} = \frac{150 \text{ k}\Omega}{22 \text{ k}\Omega} = 6.8$   
 $f_{c(cl)} = \frac{A_{ol}f_{c(ol)}}{A_{cl}} = \frac{(120,000)(150 \text{ Hz})}{6.8} = 2.65 \text{ MHz}$   
 $BW = f_{c(cl)} = \mathbf{2.65 \text{ MHz}}$
- (b)  $A_{cl} = \frac{1.0 \text{ M}\Omega}{10 \text{ k}\Omega} = 100$   
 $f_{c(cl)} = \frac{A_{ol}f_{c(ol)}}{A_{cl}} = \frac{(195,000)(50 \text{ Hz})}{100} = 97.5 \text{ kHz}$   
 $BW = f_{c(cl)} = \mathbf{97.5 \text{ kHz}}$

### ***Section 12-9 Troubleshooting***

41. (a) Faulty op-amp or open  $R_1$   
 (b)  $R_2$  open, forcing open-loop operation
42. (a) Circuit becomes a voltage-follower and the output replicates the input.  
 (b) Output will saturate.  
 (c) No effect on the ac; may add or subtract a small dc voltage to the output.  
 (d) The voltage gain will change from 10 to 0.1.
43. The gain becomes a fixed  $-100$  with no effect as the potentiometer is adjusted.

### ***System Application Problems***

44. The push-pull stage will operate nonlinearly if  $D_1$  or  $D_2$  is shorted,  $Q_1$  or  $Q_2$  is faulty, the op-amp stage has excessive gain, or if  $R_6$  is open or shorted.
45. If a  $2.2\text{ M}\Omega$  resistor is used for  $R_3$ , the gain of the op amp will be ten times too high, probably causing a clipped output waveform.
46. If  $D_1$  opens, the emitter current of  $Q_1$  is diverted to the base of  $Q_2$  producing saturation.  $Q_3$  will also saturate. The result is a signal voltage of  $0\text{ V}$  on the output.

### ***Data Sheet Problems***

47. From the data sheet of textbook Figure 12-67:

$$B = \frac{470\ \Omega}{47\ \text{k}\Omega + 470\ \Omega} = 0.0099$$

$$A_{ol} = 200,000 \text{ (typical)}$$

$$Z_{in} = 2.0\ \text{M}\Omega \text{ (typical)}$$

$$Z_{out} = 25\ \Omega \text{ (typical)}$$

$$Z_{in(NI)} = (1 + 0.0099)(200,000)(2\ \text{M}\Omega) = (1 + 1980)2\ \text{M}\Omega = 3.96\ \text{G}\Omega$$

48. From the data sheet in Figure 12-67:

$$Z_{in(I)} = R_i = \frac{R_f}{A_{cl}} = \frac{100\ \text{k}\Omega}{100} = 1\ \text{k}\Omega$$

49.  $A_{ol} = 50\ \text{V/mV} = \frac{50\ \text{V}}{1\ \text{mV}} = \frac{50,000\ \text{V}}{1\ \text{V}} = 50,000$

50. Slew rate =  $0.5\ \text{V}/\mu\text{s}$   
 $\Delta V = 8\ \text{V} - (-8\ \text{V}) = 16\ \text{V}$   
 $\Delta t = \frac{16\ \text{V}}{0.5\ \text{V}/\mu\text{s}} = 32\ \mu\text{s}$

# Chapter 12

## Advanced Problems

51. Using available standard values of  $R_f = 150 \text{ k}\Omega$  and  $R_i = 1.0 \text{ k}\Omega$ ,

$$A_v = 1 + \frac{150 \text{ k}\Omega}{1.0 \text{ k}\Omega} = 151$$

$$B = \frac{1.0 \text{ k}\Omega}{151 \text{ k}\Omega} = 6.62 \times 10^{-3}$$

$$Z_{in(NI)} = (1 + (6.62 \times 10^{-3})(50,000))300 \text{ k}\Omega = 99.6 \text{ M}\Omega$$

The compensating resistor is

$$R_c = R_i \parallel R_f = 150 \text{ k}\Omega \parallel 1.0 \text{ k}\Omega = 993 \text{ }\Omega$$

See Figure 12-3.

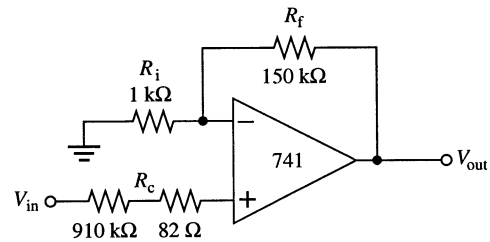

Figure 12-3

52. See Figure 12-4. 2% tolerance resistors are used to achieve a 5% gain tolerance.

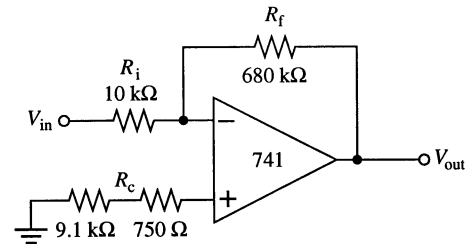

Figure 12-4

53. From textbook Figure 12-68:  
 $f_c = 10 \text{ kHz}$  at  $A_v = 40 \text{ dB} = 100$   
 In this circuit

$$A_v = 1 + \frac{33 \text{ k}\Omega}{333 \text{ }\Omega} = 100.1 \cong 100$$

The compensating resistor is

$$R_c = 33 \text{ k}\Omega \parallel 333 \text{ }\Omega = 330 \text{ }\Omega$$

See Figure 12-5.

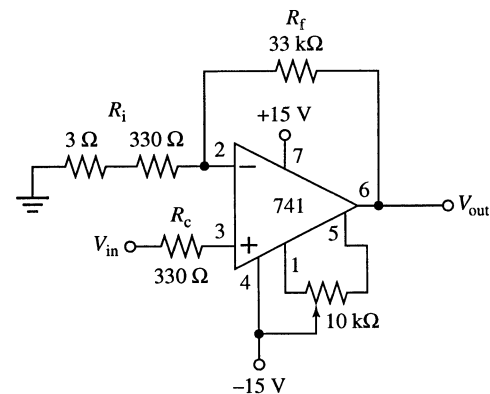

Figure 12-5

54. From textbook Figure 12-69:  
 For a  $\pm 10$  V output swing minimum, the load must be  $600\ \Omega$  for a  $\pm 10$  V and  $\approx 620\ \Omega$  for  $-10$  V. So, the minimum load is **620  $\Omega$** .

55. For the amplifier,

$$A_v = -\frac{100\ \text{k}\Omega}{2\ \text{k}\Omega} = -50$$

The compensating resistor is

$$R_c = 100\ \text{k}\Omega \parallel 2\ \text{k}\Omega = 1.96\ \text{k}\Omega \cong 2\ \text{k}\Omega$$

See Figure 12-6.

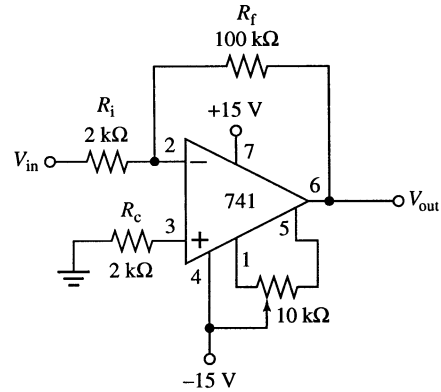

**Figure 12-6**

56. From textbook Figure 12-68 the maximum 741 closed loop gain with  $BW = 5$  kHz is approximately  $60\ \text{dB} - (20\ \text{dB})\log(5\ \text{kHz})/1\ \text{kHz} = 60\ \text{dB} - (20\ \text{dB})(0.7) = \mathbf{46\ \text{dB}}$

$$A_{v(\text{dB})} = 20 \log A_v$$

$$A_v = \log^{-1}\left(\frac{A_{v(\text{dB})}}{20}\right) = \log^{-1}\left(\frac{46}{20}\right) = \mathbf{200}$$

## EWB/Multisim Troubleshooting Problems

The solutions showing instrument connections for Problems 57 through 72 are available in the Solutions folder for Chapter 12 on the CD-ROM provided with the textbook. The solutions may be accessed using the password *ED5FLOYD*. The faults in the circuit files may be accessed using the password *book* (all lowercase).

- 57.  $R_f$  open
- 58.  $R_i$  open
- 59.  $R_f$  leaky
- 60.  $R_i$  shorted
- 61.  $R_f$  shorted
- 62. Op-amp input to output open

## Chapter 12

---

- 63.  $R_f$  leaky
- 64.  $R_i$  leaky
- 65.  $R_i$  shorted
- 66.  $R_i$  open
- 67.  $R_f$  open
- 68.  $R_f$  leaky
- 69.  $R_f$  open
- 70.  $R_f$  shorted
- 71.  $R_i$  open
- 72.  $R_i$  leaky



# Chapter 13

## Basic Op-Amp Applications

---

### Section 13-1 Comparators

- $V_{out(p)} = A_{ol}V_{in} = (80,000)(0.15 \text{ mV})(1.414) = 16.9 \text{ V}$   
 Since 12 V is the peak limit, the op-amp saturates.  
 $V_{out(pp)} = 24 \text{ V}$  with distortion due to clipping.
- (a) Maximum negative  
 (b) Maximum positive  
 (c) Maximum negative
- $$V_{UTP} = \left( \frac{R_2}{R_1 + R_2} \right) (+10 \text{ V}) = \left( \frac{18 \text{ k}\Omega}{65 \text{ k}\Omega} \right) 10 \text{ V} = 2.77 \text{ V}$$

$$V_{LTP} = \left( \frac{R_2}{R_1 + R_2} \right) (-10 \text{ V}) = \left( \frac{18 \text{ k}\Omega}{65 \text{ k}\Omega} \right) (-10 \text{ V}) = -2.77 \text{ V}$$
- $V_{HYS} = V_{UTP} - V_{LTP} = 2.77 \text{ V} - (-2.77 \text{ V}) = 5.54 \text{ V}$
- See Figure 13-1.

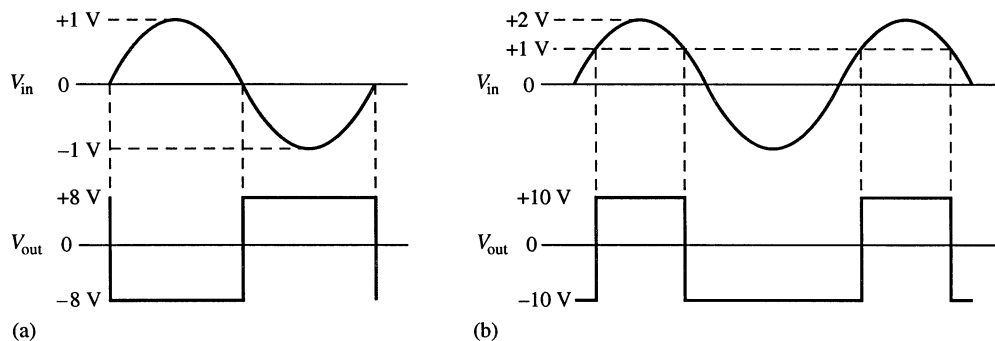

**Figure 13-1**

## Chapter 13

$$6. \quad V_{\text{UTP}} = \left( \frac{R_2}{R_1 + R_2} \right) (+V_{\text{out(max)}}) = \left( \frac{18 \text{ k}\Omega}{51 \text{ k}\Omega} \right) 11 \text{ V} = 3.88 \text{ V}$$

$$V_{\text{LTP}} = -3.88 \text{ V}$$

$$V_{\text{HYS}} = V_{\text{UTP}} - V_{\text{LTP}} = 3.88 \text{ V} - (-3.88 \text{ V}) = \mathbf{7.76 \text{ V}}$$

$$V_{\text{UTP}} = \left( \frac{R_2}{R_1 + R_2} \right) (+V_{\text{out(max)}}) = \left( \frac{68 \text{ k}\Omega}{218 \text{ k}\Omega} \right) 11 \text{ V} = 3.43 \text{ V}$$

$$V_{\text{LTP}} = -3.43 \text{ V}$$

$$V_{\text{HYS}} = V_{\text{UTP}} - V_{\text{LTP}} = 3.43 \text{ V} - (-3.43 \text{ V}) = \mathbf{6.86 \text{ V}}$$

7. When the zener is forward-biased:

$$V_{\text{out}} = \left( \frac{18 \text{ k}\Omega}{18 \text{ k}\Omega + 47 \text{ k}\Omega} \right) V_{\text{out}} - 0.7 \text{ V}$$

$$V_{\text{out}} = (0.277)V_{\text{out}} - 0.7 \text{ V}$$

$$V_{\text{out}}(1 - 0.277) = -0.7 \text{ V}$$

$$V_{\text{out}} = \frac{-0.7 \text{ V}}{1 - 0.277} = \mathbf{-0.968 \text{ V}}$$

When the zener is reverse-biased:

$$V_{\text{out}} = \left( \frac{18 \text{ k}\Omega}{18 \text{ k}\Omega + 47 \text{ k}\Omega} \right) V_{\text{out}} + 6.2 \text{ V}$$

$$V_{\text{out}} = (0.277)V_{\text{out}} + 6.2 \text{ V}$$

$$V_{\text{out}}(1 - 0.277) = +6.2 \text{ V}$$

$$V_{\text{out}} = \frac{+6.2 \text{ V}}{1 - 0.277} = \mathbf{+8.57 \text{ V}}$$

$$8. \quad V_{\text{out}} = \left( \frac{10 \text{ k}\Omega}{10 \text{ k}\Omega + 47 \text{ k}\Omega} \right) V_{\text{out}} \pm (4.7 \text{ V} + 0.7 \text{ V})$$

$$V_{\text{out}} = (0.175)V_{\text{out}} \pm 5.4 \text{ V}$$

$$V_{\text{out}} = \frac{\pm 5.4 \text{ V}}{1 - 0.175} = \pm 6.55 \text{ V}$$

$$V_{\text{UTP}} = (0.175)(+6.55 \text{ V}) = +1.15 \text{ V}$$

$$V_{\text{LTP}} = (0.175)(-6.55 \text{ V}) = -1.15 \text{ V}$$

See Figure 13-2.

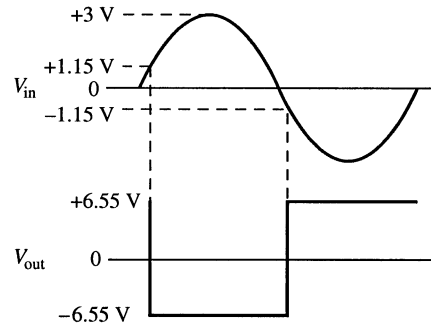

Figure 13-2

**Section 13-2 Summing Amplifiers**

9. (a)  $V_{OUT} = -\frac{R_f}{R_i} (+1\text{ V} + 1.5\text{ V}) = -1(1\text{ V} + 1.5\text{ V}) = -2.5\text{ V}$   
 (b)  $V_{OUT} = -\frac{R_f}{R_i} (0.1\text{ V} + 1\text{ V} + 0.5\text{ V}) = -\frac{22\text{ k}\Omega}{10\text{ k}\Omega} (1.6\text{ V}) = -3.52\text{ V}$

10. (a)  $V_{R1} = 1\text{ V}$   
 $V_{R2} = 1.8\text{ V}$

(b)  $I_{R1} = \frac{1\text{ V}}{22\text{ k}\Omega} = 45.5\text{ }\mu\text{A}$   
 $I_{R2} = \frac{1.8\text{ V}}{22\text{ k}\Omega} = 81.8\text{ }\mu\text{A}$   
 $I_f = I_{R1} + I_{R2} = 45.5\text{ }\mu\text{A} + 81.8\text{ }\mu\text{A} = 127\text{ }\mu\text{A}$

(c)  $V_{OUT} = -I_f R_f = -(127.27\text{ }\mu\text{A})(22\text{ k}\Omega) = -2.8\text{ V}$

11.  $5V_{in} = \left(\frac{R_f}{R}\right)V_{in}$   
 $\frac{R_f}{R} = 5$   
 $R_f = 5R = 5(22\text{ k}\Omega) = 110\text{ k}\Omega$

12. See Figure 13-3.

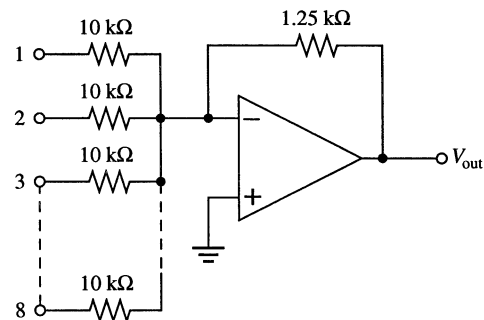

**Figure 13-3**

13.  $V_{OUT} = -\left[\left(\frac{R_f}{R_1}\right)V_1 + \left(\frac{R_f}{R_2}\right)V_2 + \left(\frac{R_f}{R_3}\right)V_3 + \left(\frac{R_f}{R_4}\right)V_4\right]$   
 $= -\left[\left(\frac{10\text{ k}\Omega}{10\text{ k}\Omega}\right)2\text{ V} + \left(\frac{10\text{ k}\Omega}{33\text{ k}\Omega}\right)3\text{ V} + \left(\frac{10\text{ k}\Omega}{91\text{ k}\Omega}\right)3\text{ V} + \left(\frac{10\text{ k}\Omega}{180\text{ k}\Omega}\right)6\text{ V}\right]$   
 $= -(2\text{ V} + 0.91\text{ V} + 0.33\text{ V} + 0.33\text{ V}) = -3.57\text{ V}$

$I_f = \frac{V_{OUT}}{R_f} = \frac{3.57\text{ V}}{10\text{ k}\Omega} = 357\text{ }\mu\text{A}$

## Chapter 13

14.  $R_f = 100 \text{ k}\Omega$   
 Input resistors:  $R_1 = 100 \text{ k}\Omega$ ,  $R_2 = 50 \text{ k}\Omega$ ,  $R_3 = 25 \text{ k}\Omega$ ,  $R_4 = 12.5 \text{ k}\Omega$ ,  
 $R_5 = 6.25 \text{ k}\Omega$ ,  $R_6 = 3.125 \text{ k}\Omega$

### Section 13-3 Integrators and Differentiators

15. 
$$\frac{dV_{out}}{dt} = -\frac{V_{IN}}{RC} = -\frac{5 \text{ V}}{(56 \text{ k}\Omega)(0.02 \text{ }\mu\text{F})} = -4.46 \text{ mV}/\mu\text{s}$$

16. See Figure 13-4.

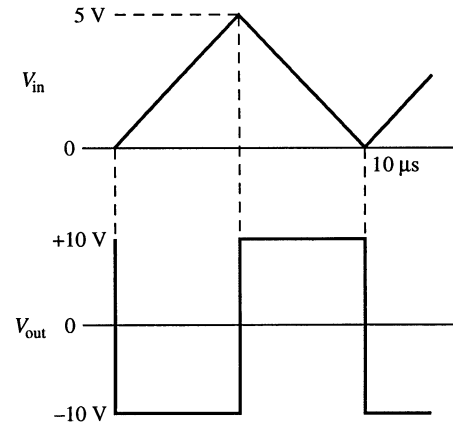

Figure 13-4

17. 
$$I = \frac{CV_{pp}}{T/2} = \frac{(0.001 \text{ }\mu\text{F})(5 \text{ V})}{10 \text{ }\mu\text{s}/2} = 1 \text{ mA}$$

18. 
$$V_{out} = \pm RC \left( \frac{V_{pp}}{T/2} \right) = \pm (15 \text{ k}\Omega)(0.05 \text{ }\mu\text{F}) \left( \frac{2 \text{ V}}{0.5 \text{ ms}} \right) = \pm 3 \text{ V}$$

See Figure 13-5.

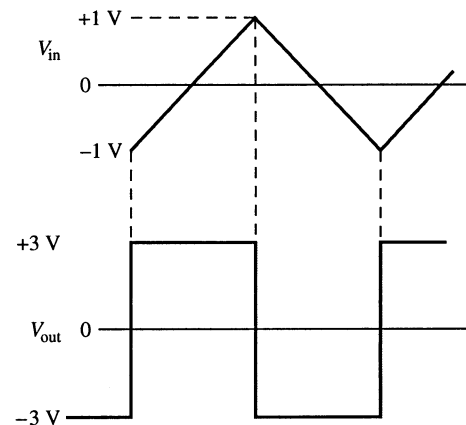

Figure 13-5

19. For the 10 ms interval when the switch is in position 2:

$$\frac{\Delta V_{out}}{\Delta t} = -\frac{V_{IN}}{RC} = -\frac{5 \text{ V}}{(10 \text{ k}\Omega)(10 \mu\text{F})} = -\frac{5 \text{ V}}{0.1 \text{ s}} = -50 \text{ V/s} = -50 \text{ mV/ms}$$

$$\Delta V_{out} = (-50 \text{ mV/ms})(10 \text{ ms}) = -500 \text{ mV} = -0.5 \text{ V}$$

For the 10 ms interval when the switch is in position 1:

$$\frac{\Delta V_{out}}{\Delta t} = -\frac{V_{IN}}{RC} = -\frac{-5 \text{ V}}{(10 \text{ k}\Omega)(10 \mu\text{F})} = -\frac{-5 \text{ V}}{0.1 \text{ s}} = +50 \text{ V/s} = +50 \text{ mV/ms}$$

$$\Delta V_{out} = (+50 \text{ mV/ms})(10 \text{ ms}) = +500 \text{ mV} = +0.5 \text{ V}$$

See Figure 13-6.

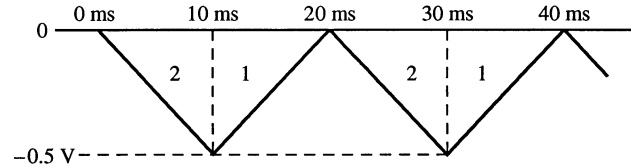

Figure 13-6

### Section 13-4 Troubleshooting

20. 
$$V_B = \left( \frac{R_2}{R_1 + R_2} \right) V_{out} \pm (V_Z + 0.7 \text{ V})$$

$$V_B = \frac{\pm (V_Z + 0.7 \text{ V})}{1 - \left( \frac{R_2}{R_1 + R_2} \right)}$$

Normally,  $V_B$  should be

$$V_B = \frac{\pm (4.3 \text{ V} + 0.7 \text{ V})}{1 - 0.5} = \pm 10 \text{ V}$$

Since the negative portion of  $V_B$  is only  $-1.4 \text{ V}$ , zener  $D_2$  must be shorted:

$$V_B = \frac{-(0 \text{ V} + 0.7 \text{ V})}{1 - 0.5} = 1.4 \text{ V}$$

21. The output should be as shown in Figure 13-7.  $V_2$  has no effect on the output. This indicates that  $R_2$  is open.

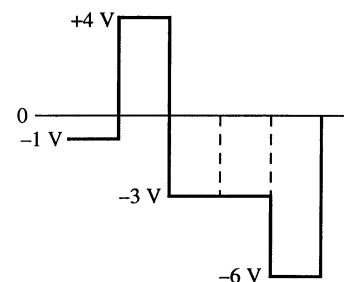

Figure 13-7

## Chapter 13

22. 
$$A_v = \frac{2.5 \text{ k}\Omega}{10 \text{ k}\Omega} = 0.25$$

The output should be as shown in Figure 13-8. An open  $R_2$  ( $V_2$  is missing) will produce the observed output, which is incorrect.

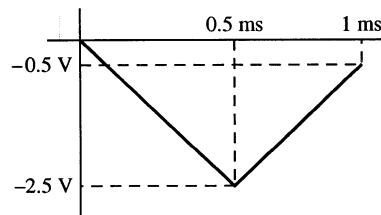

Figure 13-8

23. The  $D_2$  input is missing (acts as a constant 0). This indicates an open  $50 \text{ k}\Omega$  resistor.

### System Application Problems

24. The first thing that you should always do is visually inspect the circuit for bad contacts or loose connections, shorts from solder splashes or wire clippings, incorrect components, and incorrectly installed components. In this case, after careful inspection, you will find that the **middle op-amp IC is installed incorrectly** (notice where pin 1 is as indicated by the dot).
25. An open integrator capacitor will cause the output of IC2 to saturate positively.
26. If a  $1.0 \text{ k}\Omega$  resistor is used for  $R_1$ , the output of IC2 will be ten times larger for the sample-and-hold operation most likely causing the integrator to ramp into saturation.

### Advanced Problems

27. For a 741S op amp with a  $12 \text{ V}/\mu\text{s}$  slew rate and  $500 \text{ kHz}$  sample pulse rate, the ramp up and ramp down must take

$$\tau = \frac{1}{500 \text{ kHz}} = 2 \mu\text{s}$$

With a fixed interval of  $1 \mu\text{s}$  for ramp up, this leaves a  $1 \mu\text{s}$  ramp down interval.

If  $-V_{\text{REF}} = -8 \text{ V}$  as in the system application, with a  $-8 \text{ V}/\mu\text{s}$  ramp down rate, the ramp down can accommodate an  $8 \text{ V}$  ramp-up peak corresponding to  $+8 \text{ V}$  input. However, if full slew rate is utilized as a  $-12 \text{ V}$  reference voltage is used, a  $+12 \text{ V}$  input can be accommodated.

28. A maximum of  $+0.5$  can be used.
29.  $100 \text{ mV}/\mu\text{s} = 5 \text{ V}/R_i C$   

$$R_i C = \frac{5 \text{ V}}{100 \text{ mV}/\mu\text{s}} = 50 \mu\text{s}$$
 For  $C = 3300 \text{ pF}$ :  

$$R_i = \frac{50 \mu\text{s}}{3300 \text{ pF}} = 15.15 \text{ k}\Omega = 15 \text{ k}\Omega + 150 \Omega$$

For a 5 V peak-peak triangle waveform:

$$t_{\text{ramp up}} = t_{\text{ramp down}} = \frac{5 \text{ V}}{100 \text{ mV}/\mu\text{s}} = 50 \mu\text{s}$$

$$\tau = 2(50 \mu\text{s}) = 100 \mu\text{s}$$

$$f_{\text{in}} = 1/100 \mu\text{s} = \mathbf{100 \text{ kHz}}$$

See Figure 13-9.

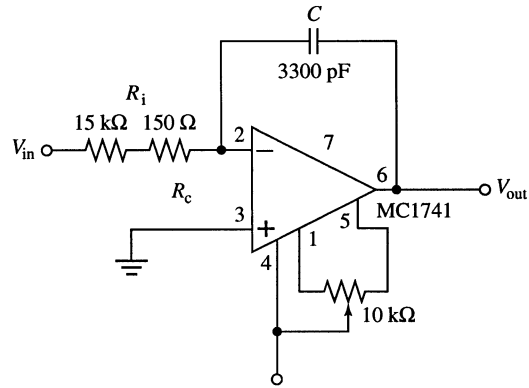

**Figure 13-9**

## EWB/Multisim Troubleshooting Problems

The solutions showing instrument connections for Problems 30 through 39 are available in the Solutions folder for Chapter 13 on the CD-ROM provided with the textbook. The solutions may be accessed using the password *ED5FLOYD*. The faults in the circuit files may be accessed using the password *book* (all lowercase).

30.  $R_1$  open
31. Op-amp inputs shorted together
32. Op-amp + input to output shorted
33.  $D_1$  shorted
34. Top 10 kΩ resistor open
35. Middle 10 kΩ resistor shorted
36.  $R_f$  leaky
37.  $R_f$  open
38.  $C$  leaky
39.  $C$  open

# Chapter 14

## Special-Purpose Op-Amp Circuits

---

### Section 14-1 Instrumentation Amplifiers

1. 
$$A_{v(1)} = 1 + \frac{R_1}{R_G} = 1 + \frac{100 \text{ k}\Omega}{1.0 \text{ k}\Omega} = 101$$

$$A_{v(2)} = 1 + \frac{R_2}{R_G} = 1 + \frac{100 \text{ k}\Omega}{1.0 \text{ k}\Omega} = 101$$

2. 
$$A_{cl} = 1 + \frac{2R}{R_G} = 1 + \frac{200 \text{ k}\Omega}{1.0 \text{ k}\Omega} = 201$$

3. 
$$V_{out} = A_{cl}(V_{in(2)} - V_{in(1)}) = 202(10 \text{ mV} - 5 \text{ mV}) = 1.005 \text{ V}$$

4. 
$$A_v = 1 + \frac{2R}{R_G}$$

$$\frac{2R}{R_G} = A_v - 1$$

$$R_G = \frac{2R}{A_v - 1} = \frac{2(100 \text{ k}\Omega)}{1000 - 1} = \frac{200 \text{ k}\Omega}{999} = 200.2 \text{ }\Omega \cong 200 \text{ }\Omega$$

5. 
$$R_G = \frac{50.5 \text{ k}\Omega}{A_v - 1}$$

$$A_v = \frac{50.5 \text{ k}\Omega}{1.0 \text{ k}\Omega} + 1 = 51.5$$

6. Using the graph in textbook Figure 14-6,  
 $BW \cong 300 \text{ kHz}$

7. Change  $R_G$  to

$$R_G = \frac{50.5 \text{ k}\Omega}{A_v - 1} = \frac{50.5 \text{ k}\Omega}{24 - 1} \cong 2.2 \text{ k}\Omega$$

8. 
$$R_G = \frac{50.5 \text{ k}\Omega}{A_v - 1} = \frac{50.5 \text{ k}\Omega}{20 - 1} \cong 2.7 \text{ k}\Omega$$



**Section 14-2 Isolation Amplifiers**

9.  $A_{v(total)} = (30)(10) = \mathbf{300}$

10. (a)  $A_{v1} = \frac{R_{f1}}{R_{i1}} + 1 = \frac{18 \text{ k}\Omega}{8.2 \text{ k}\Omega} + 1 = 3.2$

$$A_{v2} = \frac{R_{f1}}{R_{i1}} + 1 = \frac{150 \text{ k}\Omega}{15 \text{ k}\Omega} + 1 = 11$$

$$A_{v(total)} = A_{v1}A_{v2} = (3.2)(11) = \mathbf{35.2}$$

(b)  $A_{v1} = \frac{R_{f1}}{R_{i1}} + 1 = \frac{330 \text{ k}\Omega}{1.0 \text{ k}\Omega} + 1 = 331$

$$A_{v2} = \frac{R_{f1}}{R_{i1}} + 1 = \frac{47 \text{ k}\Omega}{15 \text{ k}\Omega} + 1 = 4.13$$

$$A_{v(total)} = A_{v1}A_{v2} = (331)(4.13) = \mathbf{1,367}$$

11.  $A_{v2} = 4.13$  (from Problem 10)

$$A_{v1}A_{v2} = 100$$

$$\frac{R_{f1}}{R_{i1}} + 1 = A_{v1} = \frac{100}{4.13} = 24.2$$

Change  $R_f$  (18 k $\Omega$ ) to 23.2 k $\Omega$ .

Use **23.2 k $\Omega$   $\pm$  1%** standard value resistor.

12.  $A_{v1} = 331$  (from Problem 10)

$$A_{v1}A_{v2} = 440$$

$$\frac{R_{f2}}{R_{i2}} + 1 = A_{v2} = \frac{440}{331} = 1.33$$

Change  $R_f$  (47 k $\Omega$ ) to 3.3 k $\Omega$ .

Change  $R_i$  (15 k $\Omega$ ) to 10 k $\Omega$ .

13. Connect pin 6 to pin 10 and pin 14 to pin 15.

**Section 14-3 Operational Transconductance Amplifiers (OTAs)**

14.  $g_m = \frac{I_{out}}{V_{in}} = \frac{10 \text{ }\mu\text{A}}{10 \text{ mV}} = \mathbf{1 \text{ mS}}$

15.  $I_{out} = g_m V_{in} = (5000 \text{ }\mu\text{S})(100 \text{ mV}) = \mathbf{500 \text{ }\mu\text{A}}$   
 $V_{out} = I_{out} R_L = (500 \text{ }\mu\text{A})(10 \text{ k}\Omega) = \mathbf{5 \text{ V}}$

16.  $g_m = \frac{I_{out}}{V_{in}}$   
 $I_{out} = g_m V_{in} = (4000 \text{ }\mu\text{S})(100 \text{ mV}) = 400 \text{ }\mu\text{A}$   
 $R_L = \frac{V_{out}}{I_{out}} = \frac{3.5 \text{ V}}{400 \text{ }\mu\text{A}} = \mathbf{8.75 \text{ k}\Omega}$

## Chapter 14

---

$$17. \quad I_{\text{BIAS}} = \frac{+12 \text{ V} - (-12 \text{ V}) - 0.7 \text{ V}}{R_{\text{BIAS}}} = \frac{+12 \text{ V} - (-12 \text{ V}) - 0.7 \text{ V}}{220 \text{ k}\Omega} = \frac{23.3 \text{ V}}{220 \text{ k}\Omega} = 106 \mu\text{A}$$

From the graph in Figure 14-44:

$$g_m = KI_{\text{BIAS}} \cong (16 \mu\text{S}/\mu\text{A})(106 \mu\text{A}) = 1.70 \text{ mS}$$

$$A_v = \frac{V_{\text{out}}}{V_{\text{in}}} = \frac{I_{\text{out}} R_L}{V_{\text{in}}} = g_m R_L = (1.70 \text{ mS})(6.8 \text{ k}\Omega) = 11.6$$

18. The maximum voltage gain occurs when the 10 k $\Omega$  potentiometer is set to 0  $\Omega$  and was determined in Problem 17.

$$A_{v(\text{max})} = 11.6$$

The minimum voltage gain occurs when the 10 k $\Omega$  potentiometer is set to 10 k $\Omega$ .

$$I_{\text{BIAS}} = \frac{+12 \text{ V} - (-12 \text{ V}) - 0.7 \text{ V}}{220 \text{ k}\Omega + 10 \text{ k}\Omega} = \frac{23.3 \text{ V}}{230 \text{ k}\Omega} = 101 \mu\text{A}$$

$$g_m \cong (16 \mu\text{S}/\mu\text{A})(101 \mu\text{A}) = 1.62 \text{ mS}$$

$$A_{v(\text{min})} = g_m R_L = (1.62 \text{ mS})(6.8 \text{ k}\Omega) = 11.0$$

19. The  $V_{\text{MOD}}$  waveform is applied to the bias input. The gain and output voltage for each value of  $V_{\text{MOD}}$  is determined as follows using  $K = 16 \mu\text{S}/\mu\text{A}$ . The output waveform is shown in Figure 14-1.

For  $V_{\text{MOD}} = +8 \text{ V}$ :

$$I_{\text{BIAS}} = \frac{+8 \text{ V} - (-9 \text{ V}) - 0.7 \text{ V}}{39 \text{ k}\Omega} = \frac{16.3 \text{ V}}{39 \text{ k}\Omega} = 418 \mu\text{A}$$

$$g_m = KI_{\text{BIAS}} \cong (16 \mu\text{S}/\mu\text{A})(418 \mu\text{A}) = 6.69 \text{ mS}$$

$$A_v = \frac{V_{\text{out}}}{V_{\text{in}}} = \frac{I_{\text{out}} R_L}{V_{\text{in}}} = g_m R_L = (6.69 \text{ mS})(10 \text{ k}\Omega) = 66.9$$

$$V_{\text{out}} = A_v V_{\text{in}} = (66.9)(100 \text{ mV}) = 6.69 \text{ V}$$

For  $V_{\text{MOD}} = +6 \text{ V}$ :

$$I_{\text{BIAS}} = \frac{+6 \text{ V} - (-9 \text{ V}) - 0.7 \text{ V}}{39 \text{ k}\Omega} = \frac{14.3 \text{ V}}{39 \text{ k}\Omega} = 367 \mu\text{A}$$

$$g_m = KI_{\text{BIAS}} \cong (16 \mu\text{S}/\mu\text{A})(367 \mu\text{A}) = 5.87 \text{ mS}$$

$$A_v = \frac{V_{\text{out}}}{V_{\text{in}}} = \frac{I_{\text{out}} R_L}{V_{\text{in}}} = g_m R_L = (5.87 \text{ mS})(10 \text{ k}\Omega) = 58.7$$

$$V_{\text{out}} = A_v V_{\text{in}} = (58.7)(100 \text{ mV}) = 5.87 \text{ V}$$

For  $V_{MOD} = +4$  V:

$$I_{BIAS} = \frac{+4 \text{ V} - (-9 \text{ V}) - 0.7 \text{ V}}{39 \text{ k}\Omega} = \frac{12.3 \text{ V}}{39 \text{ k}\Omega} = 315 \mu\text{A}$$

$$g_m = KI_{BIAS} \cong (16 \mu\text{S}/\mu\text{A})(315 \mu\text{A}) = 5.04 \text{ mS}$$

$$A_v = \frac{V_{out}}{V_{in}} = \frac{I_{out}R_L}{V_{in}} = g_mR_L = (5.04 \text{ mS})(10 \text{ k}\Omega) = 50.4$$

$$V_{out} = A_vV_{in} = (50.4)(100 \text{ mV}) = \mathbf{5.04 \text{ V}}$$

For  $V_{MOD} = +2$  V:

$$I_{BIAS} = \frac{+2 \text{ V} - (-9 \text{ V}) - 0.7 \text{ V}}{39 \text{ k}\Omega} = \frac{10.3 \text{ V}}{39 \text{ k}\Omega} = 264 \mu\text{A}$$

$$g_m = KI_{BIAS} \cong (16 \mu\text{S}/\mu\text{A})(264 \mu\text{A}) = 4.22 \text{ mS}$$

$$A_v = \frac{V_{out}}{V_{in}} = \frac{I_{out}R_L}{V_{in}} = g_mR_L = (4.22 \text{ mS})(10 \text{ k}\Omega) = 42.2$$

$$V_{out} = A_vV_{in} = (42.2)(100 \text{ mV}) = \mathbf{4.22 \text{ V}}$$

For  $V_{MOD} = +1$  V:

$$I_{BIAS} = \frac{+1 \text{ V} - (-9 \text{ V}) - 0.7 \text{ V}}{39 \text{ k}\Omega} = \frac{9.3 \text{ V}}{39 \text{ k}\Omega} = 238 \mu\text{A}$$

$$g_m = KI_{BIAS} \cong (16 \mu\text{S}/\mu\text{A})(238 \mu\text{A}) = 3.81 \text{ mS}$$

$$A_v = \frac{V_{out}}{V_{in}} = \frac{I_{out}R_L}{V_{in}} = g_mR_L = (3.81 \text{ mS})(10 \text{ k}\Omega) = 38.1$$

$$V_{out} = A_vV_{in} = (38.1)(100 \text{ mV}) = \mathbf{3.81 \text{ V}}$$

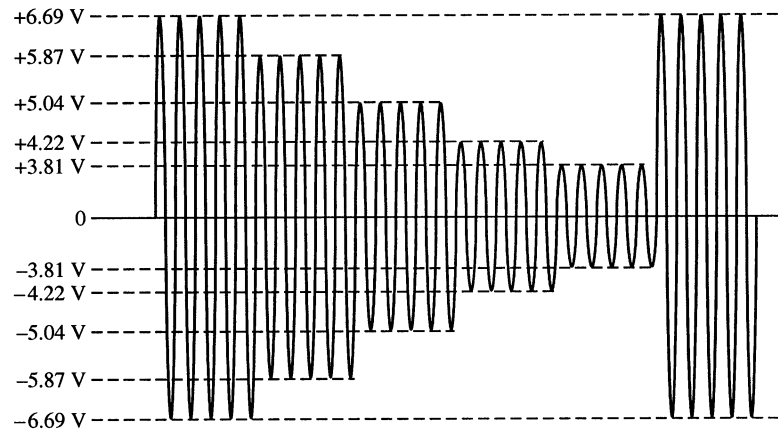

Figure 14-1

20. 
$$I_{BIAS} = \frac{+9 \text{ V} - (-9 \text{ V}) - 0.7 \text{ V}}{39 \text{ k}\Omega} = \frac{17.3 \text{ V}}{39 \text{ k}\Omega} = 444 \mu\text{A}$$

$$V_{TRIG(+)} = I_{BIAS}R_1 = (444 \mu\text{A})(10 \text{ k}\Omega) = \mathbf{+4.44 \text{ V}}$$

$$V_{TRIG(-)} = -I_{BIAS}R_1 = (-444 \mu\text{A})(10 \text{ k}\Omega) = \mathbf{-4.44 \text{ V}}$$

## Chapter 14

21. See Figure 14-2.

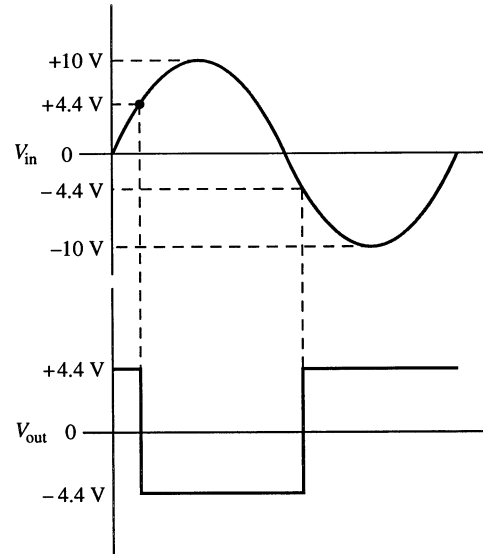

Figure 14-2

### Section 14-4 Log and Antilog Amplifiers

22. (a)  $\ln(0.5) = -0.693$   
 (b)  $\ln(2) = 0.693$   
 (c)  $\ln(50) = 3.91$   
 (d)  $\ln(130) = 4.87$
23. (a)  $\log_{10}(0.5) = -0.301$   
 (b)  $\log_{10}(2) = 0.301$   
 (c)  $\log_{10}(50) = 1.70$   
 (d)  $\log_{10}(130) = 2.11$
24. Antilog  $x = 10^x$  or  $e^x$ , depending on the base used.  
 INV  $\ln = e^{1.6} = 4.95$   
 INV  $\log = 10^{1.6} = 39.8$
25. The output of a log amplifier is limited to **0.7 V** because the output voltage is limited to the barrier potential of the transistor's *pn* junction.

$$\begin{aligned}
 26. \quad V_{out} &\cong -(0.025 \text{ V}) \ln \left( \frac{V_{in}}{I_s R_{in}} \right) \\
 &= -(0.025 \text{ V}) \ln \left( \frac{3 \text{ V}}{(100 \text{ nA})(82 \text{ k}\Omega)} \right) = -(0.025 \text{ V}) \ln(365.9) = \mathbf{-148 \text{ mV}}
 \end{aligned}$$

$$\begin{aligned}
 27. \quad V_{out} &\cong -(0.025 \text{ V}) \ln \left( \frac{V_{in}}{I_{EBO} R_{in}} \right) \\
 &= -(0.025 \text{ V}) \ln \left( \frac{1.5 \text{ V}}{(60 \text{ nA})(47 \text{ k}\Omega)} \right) = -(0.025 \text{ V}) \ln(531.9) = \mathbf{-157 \text{ mV}}
 \end{aligned}$$

28.  $V_{out} = -R_f I_{EBO} \text{antilog}\left(\frac{V_{in}}{25 \text{ mV}}\right) = -R_f I_{EBO} e^{\left(\frac{V_{in}}{25 \text{ mV}}\right)}$   
 $V_{out} = -(10 \text{ k}\Omega)(60 \text{ nA}) e^{\left(\frac{0.225 \text{ V}}{25 \text{ mV}}\right)} = -(10 \text{ k}\Omega)(60 \text{ nA}) e^9 = -(10 \text{ k}\Omega)(60 \text{ nA})(8103) = -4.86 \text{ V}$

29.  $V_{out(max)} \cong -(0.025 \text{ V}) \ln\left(\frac{V_{in}}{I_{EBO} R_{in}}\right) = -(0.025 \text{ V}) \ln\left(\frac{1 \text{ V}}{(60 \text{ nA})(47 \text{ k}\Omega)}\right)$   
 $= -(0.025 \text{ V}) \ln(354.6) = -147 \text{ mV}$   
 $V_{out(min)} \cong -(0.025 \text{ V}) \ln\left(\frac{V_{in}}{I_{EBO} R_{in}}\right) = -(0.025 \text{ V}) \ln\left(\frac{100 \text{ mV}}{(60 \text{ nA})(47 \text{ k}\Omega)}\right)$   
 $= -(0.025 \text{ V}) \ln(35.5) = -89.2 \text{ mV}$

The signal compression allows larger signals to be reduced without causing smaller amplitudes to be lost (in this case, the 1 V peak is reduced 85% but the 100 mV peak is reduced only 10%).

**Section 14-5 Converters and Other Op-Amp Circuits**

30. (a)  $V_{IN} = V_Z = 4.7 \text{ V}$   
 $I_L = \frac{V_{IN}}{R_i} = \frac{4.7 \text{ V}}{1.0 \text{ k}\Omega} = 4.7 \text{ mA}$

(b)  $V_{IN} = \left(\frac{10 \text{ k}\Omega}{20 \text{ k}\Omega}\right) 12 \text{ V} = 6 \text{ V}$   
 $R_i = 10 \text{ k}\Omega \parallel 10 \text{ k}\Omega + 100 \Omega = 5.1 \text{ k}\Omega$   
 $I_L = \frac{V_{IN}}{R_i} = \frac{6 \text{ V}}{5.1 \text{ k}\Omega} = 1.18 \text{ mA}$

31. See Figure 14-3.

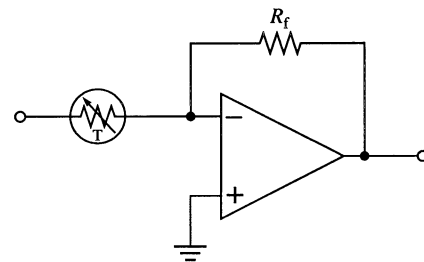

Figure 14-3

## Chapter 14

### Troubleshooting Problems

32. The circuit on this board is represented by the schematic in textbook Figure 14-38. For the isolation amplifier IC<sub>1</sub>:

$$A_{v1} = \frac{R_3}{R_2} + 1 = \frac{330 \text{ k}\Omega}{86 \text{ k}\Omega} + 1 = 3.84 + 1 = 4.84$$

$$A_{v2} = \frac{R_5}{R_4} + 1 = \frac{120 \text{ k}\Omega}{100 \text{ k}\Omega} + 1 = 2.2$$

$$A_{v(\text{total})} = A_{v1}A_{v2} = (4.84)(2.2) = 10.6$$

For the IC<sub>2</sub> filter:

$$A_{v(\text{mid})} = \frac{R_8}{R_9} + 1 = \frac{3.3 \text{ k}\Omega}{5.6 \text{ k}\Omega} + 1 = 0.59 + 1 = 1.59$$

$$f_c = \frac{1}{2\pi RC} = \frac{1}{2\pi(100 \text{ k}\Omega)(0.015 \text{ }\mu\text{F})} = 106 \text{ Hz, so the 50 Hz input is in the midrange.}$$

For IC<sub>3</sub>:

$$A_v = \frac{R_{15} + R_{16}}{R_{10}} = \frac{125 \text{ k}\Omega}{1.0 \text{ k}\Omega} = 125, \text{ assuming } R_{16} \text{ is set at } 25 \text{ k}\Omega.$$

TP 1 is at the output of IC<sub>2</sub>:

$$V_{\text{TP1}} = (1.59)(10.6 \text{ mV}) = \mathbf{16.9 \text{ mV @ 50 Hz}}$$

TP 2 is at pin 2 of IC<sub>2</sub>:

$$V_{\text{TP2}} = \left( \frac{5.6 \text{ k}\Omega}{8.9 \text{ k}\Omega} \right) V_{\text{TP1}} = \mathbf{10.6 \text{ mV @ 50 Hz}}$$

TP 3 is at the output of IC<sub>1</sub>:

$$V_{\text{TP3}} = A_{v(\text{total})}V_{in} = (10.6)(1 \text{ mV}) = \mathbf{10.6 \text{ mV @ 50 Hz}}$$

TP 4 is at the supply voltage of **+15 V DC**.

TP 5 is at the output of IC<sub>3</sub>:

$$V_{\text{TP5}} = A_v V_{\text{TP1}} = (125)(16.9 \text{ mV}) = \mathbf{2.11 \text{ V @ 50 Hz}}$$

33. The IC<sub>2</sub> filter was found in Problem 32 to have a critical frequency of 106 Hz. Therefore, the 1 kHz input signal is outside of the bandwidth.

$$V_{\text{TP1}} \cong \mathbf{0 \text{ V}}$$

$$V_{\text{TP2}} \cong \mathbf{0 \text{ V}}$$

The voltage gain of IC<sub>1</sub> was found in Problem 32 to be 10.6.

$$V_{\text{TP3}} = (10.6)(2 \text{ mV}) = \mathbf{21.2 \text{ mV @ 1 kHz}}$$

$$V_{\text{TP4}} = \mathbf{+15 \text{ V DC}}$$

$$V_{\text{TP5}} \cong \mathbf{0 \text{ V}}$$

### **EWB/Multisim Troubleshooting Problems**

The solutions showing instrument connections for Problems 34 through 38 are available in the Solutions folder for Chapter 14 on the CD-ROM provided with the textbook. The solutions may be accessed using the password *EDSFLOYD*. The faults in the circuit files may be accessed using the password *book* (all lowercase).

- 34.  $R_G$  leaky
- 35.  $R$  open
- 36.  $R_f$  open
- 37. Zener diode open
- 38. Lower 10 k $\Omega$  resistor open

# Chapter 15

## Active Filters

---

### Section 15-1 Basic Filter Responses

1. (a) Band-pass  
(b) High-pass  
(c) Low-pass  
(d) Band-stop
2.  $BW = f_c = 800 \text{ Hz}$
3.  $f_c = \frac{1}{2\pi RC} = \frac{1}{2\pi(2.2 \text{ k}\Omega)(0.0015 \text{ }\mu\text{F})} = 48.2 \text{ Hz}$   
No, the upper response roll-off due to internal device capacitances is unknown.
4. The roll-off is **20 dB/decade** because this is a single-pole filter.
5.  $BW = f_{ch} - f_{cl} = 3.9 \text{ kHz} - 3.2 \text{ kHz} = 0.7 \text{ kHz} = 700 \text{ Hz}$   
 $f_0 = \sqrt{f_{cl}f_{ch}} = \sqrt{(3.2 \text{ kHz})(3.9 \text{ kHz})} = 3.53 \text{ kHz}$   
 $Q = \frac{f_0}{BW} = \frac{3.53 \text{ kHz}}{700 \text{ Hz}} = 5.04$
6.  $Q = \frac{f_0}{BW}$   
 $f_0 = Q(BW) = 15(1 \text{ kHz}) = 15 \text{ kHz}$

### Section 15-2 Filter Response Characteristics

7. (a) 2nd order, 1 stage  
 $DF = 2 - \frac{R_3}{R_4} = 2 - \frac{1.2 \text{ k}\Omega}{1.2 \text{ k}\Omega} = 2 - 1 = 1$       **Not Butterworth**
- (b) 2nd order, 1 stage  
 $DF = 2 - \frac{R_3}{R_4} = 2 - \frac{560 \text{ }\Omega}{1.0 \text{ k}\Omega} = 2 - 0.56 = 1.44$       **Approximately Butterworth**
- (c) 3rd order, 2 stages, 1st stage (2 poles):  
 $DF = 2 - \frac{R_3}{R_4} = 2 - \frac{330 \text{ }\Omega}{1.0 \text{ k}\Omega} = 1.67$   
2nd stage (1 pole):  
 $DF = 2 - \frac{R_6}{R_7} = 1.67$       **Not Butterworth**



8. (a) From Table 15-1 in the textbook, the damping factor must be 1.414; therefore,

$$\frac{R_3}{R_4} = 0.586$$

$$R_3 = 0.586R_4 = 0.586(1.2 \text{ k}\Omega) = 703 \text{ }\Omega$$

Nearest standard value: **720  $\Omega$**

(b)  $\frac{R_3}{R_4} = 0.56$

This is an approximate Butterworth response  
(as close as you can get using standard 5% resistors).

- (c) From Table 15-1, the damping factor of both stages must be 1, therefore

$$\frac{R_3}{R_4} = 1$$

$$R_3 = R_4 = R_6 = R_7 = 1 \text{ k}\Omega \text{ (for both stages)}$$

9. (a) Chebyshev  
(b) Butterworth  
(c) Bessel  
(d) Butterworth

### Section 15-3 Active Low-Pass Filters

10. **High Pass**

1st stage:

$$DF = 2 - \frac{R_3}{R_4} = 2 - \frac{1.0 \text{ k}\Omega}{6.8 \text{ k}\Omega} = 1.85$$

2nd stage:

$$DF = 2 - \frac{R_7}{R_8} = 2 - \frac{6.8 \text{ k}\Omega}{5.6 \text{ k}\Omega} = 0.786$$

From Table 15-1 in the textbook:

1st stage  $DF = 1.848$  and 2nd stage  $DF = 0.765$

Therefore, this filter is **approximately Butterworth**.

Roll-off rate = **80 dB/decade**

11. 
$$f_c = \frac{1}{2\pi\sqrt{R_1R_2C_1C_2}} = \frac{1}{2\pi\sqrt{R_5R_6C_3C_4}} = \frac{1}{2\pi\sqrt{(4.7 \text{ k}\Omega)(6.8 \text{ k}\Omega)(0.22 \text{ }\mu\text{F})(0.1 \text{ }\mu\text{F})}} = 190 \text{ Hz}$$

12.  $R = R_1 = R_2 = R_5 = R_6$  and  $C = C_1 = C_2 = C_3 = C_4$   
Let  $C = 0.22 \text{ }\mu\text{F}$  (for both stages).

$$f_c = \frac{1}{2\pi\sqrt{R^2C^2}} = \frac{1}{2\pi RC}$$

$$R = \frac{1}{2\pi f_c C} = \frac{1}{2\pi(190 \text{ Hz})(0.22 \text{ }\mu\text{F})} = 3.81 \text{ k}\Omega$$

Choose  $R = 3.9 \text{ k}\Omega$  (for both stages)

# Chapter 15

13. See Figure 15-1.

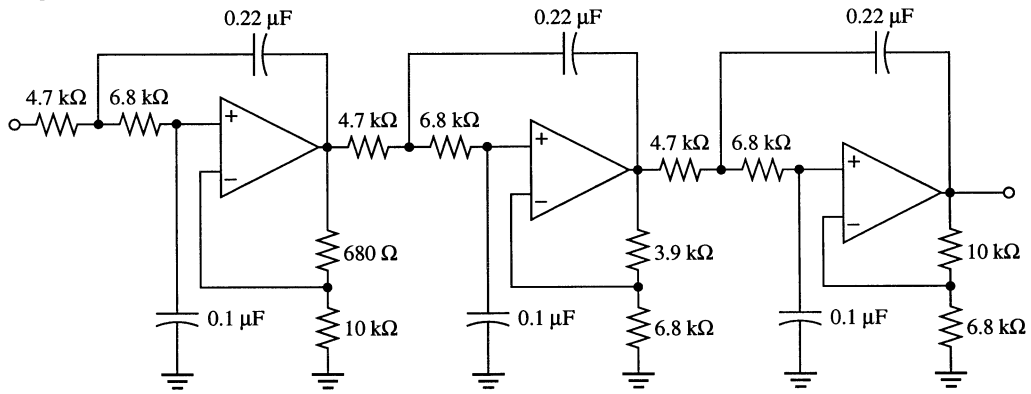

Figure 15-1

14. See Figure 15-2.

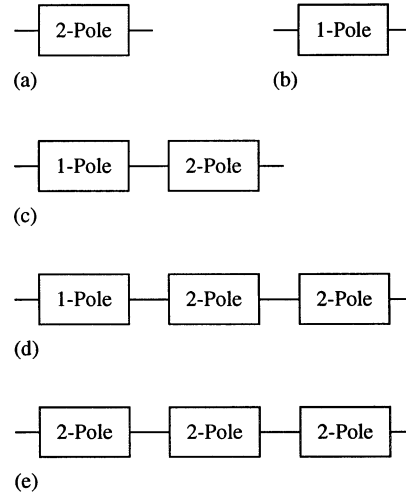

Figure 15-2

## Section 15-4 Active High-Pass Filters

15. Exchange the positions of the resistors and the capacitors. See Figure 15-3.

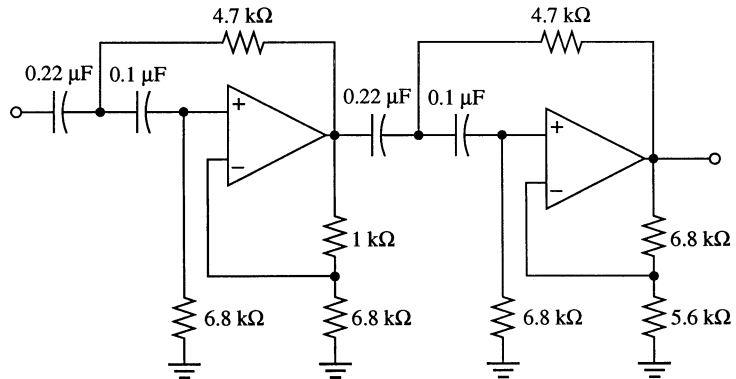

Figure 15-3

16.  $f_c = \frac{1}{2\pi RC}$   
 $f_0 = \frac{190 \text{ Hz}}{2} = 95 \text{ Hz}$   
 $R = \frac{1}{2\pi f_c C} = \frac{1}{2\pi(95 \text{ Hz})(0.22 \mu\text{F})} = 7615 \Omega$   
 Let  $R = 7.5 \text{ k}\Omega$ . Change all resistors to **7.5 k $\Omega$** .
17. (a) Decrease  $R_1$  and  $R_2$  or  $C_1$  and  $C_2$ .  
 (b) Increase  $R_3$  or decrease  $R_4$ .

**Section 15-5 Active Band-Pass Filters**

18. (a) Cascaded high-pass/low-pass filters  
 (b) Multiple feedback  
 (c) State variable

19. (a) 1st stage:  
 $f_{c1} = \frac{1}{2\pi RC} = \frac{1}{2\pi(1.0 \text{ k}\Omega)(0.047 \mu\text{F})} = 3.39 \text{ kHz}$   
 2nd stage:  
 $f_{c2} = \frac{1}{2\pi RC} = \frac{1}{2\pi(1.0 \text{ k}\Omega)(0.022 \mu\text{F})} = 7.23 \text{ kHz}$   
 $f_0 = \sqrt{f_{c1}f_{c2}} = \sqrt{(3.39 \text{ kHz})(7.23 \text{ kHz})} = \mathbf{4.95 \text{ kHz}}$   
 $BW = 7.23 \text{ kHz} - 3.39 \text{ Hz} = \mathbf{3.84 \text{ kHz}}$

(b)  $f_0 = \frac{1}{2\pi C} \sqrt{\frac{R_1 + R_2}{R_1 R_2 R_3}} = \frac{1}{2\pi(0.022 \mu\text{F})} \sqrt{\frac{47 \text{ k}\Omega + 1.8 \text{ k}\Omega}{(47 \text{ k}\Omega)(1.8 \text{ k}\Omega)(150 \text{ k}\Omega)}} = \mathbf{449 \text{ Hz}}$   
 $Q = \pi f_0 C R_3 = \pi(449 \text{ Hz})(0.022 \mu\text{F})(150 \text{ k}\Omega) = 4.66$   
 $BW = \frac{f_0}{Q} = \frac{449 \text{ Hz}}{4.66} = \mathbf{96.4 \text{ Hz}}$

(c) For each integrator:  
 $f_c = \frac{1}{2\pi RC} = \frac{1}{2\pi(10 \text{ k}\Omega)(0.001 \mu\text{F})} = 1.59 \text{ kHz}$   
 $f_0 = f_c = \mathbf{15.9 \text{ kHz}}$   
 $Q = \frac{1}{3} \left( \frac{R_5}{R_6} + 1 \right) = \frac{1}{3} \left( \frac{560 \text{ k}\Omega}{10 \text{ k}\Omega} + 1 \right) = \frac{1}{3} (56 + 1) = 19$   
 $BW = \frac{f_0}{Q} = \frac{15.9 \text{ kHz}}{19} = \mathbf{838 \text{ Hz}}$

## Chapter 15

$$20. \quad Q = \frac{1}{3} \left( \frac{R_5}{R_6} + 1 \right)$$

Select  $R_6 = 10 \text{ k}\Omega$ .

$$Q = \frac{R_5}{3R_6} + \frac{1}{3} = \frac{R_5 + R_6}{3R_6}$$

$$3R_6Q = R_5 + R_6$$

$$R_5 = 3R_6Q - R_6 = 3(1.0 \text{ k}\Omega)(50) - 10 \text{ k}\Omega = 150 \text{ k}\Omega - 10 \text{ k}\Omega = 140 \text{ k}\Omega$$

$$f_0 = \frac{1}{2\pi(12 \text{ k}\Omega)(0.01 \mu\text{F})} = 1.33 \text{ kHz}$$

$$BW = \frac{f_0}{Q} = \frac{1.33 \text{ kHz}}{50} = 26.6 \text{ Hz}$$

### Section 15-6 Active Band-Stop Filters

21. See Figure 15-4.

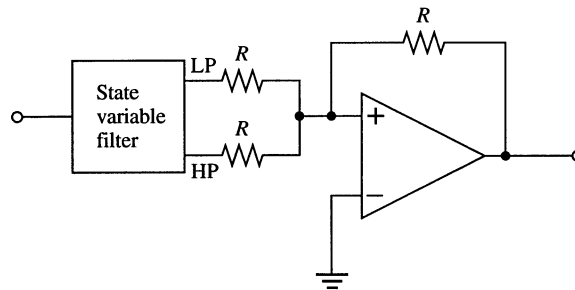

Figure 15-4

$$22. \quad f_0 = f_c = \frac{1}{2\pi RC}$$

Let  $C$  remain  $0.01 \mu\text{F}$ .

$$R = \frac{1}{2\pi f_0 C} = \frac{1}{2\pi(120 \text{ Hz})(0.01 \mu\text{F})} = 133 \text{ k}\Omega$$

Change  $R$  in the integrators from  $12 \text{ k}\Omega$  to  $133 \text{ k}\Omega$ .

### EWB/Multisim Troubleshooting Problems

The solutions showing instrument connections for Problems 23 through 31 are available in the Solutions folder for Chapter 15 on the CD-ROM provided with the textbook. The solutions may be accessed using the password *ED5FLOYD*. The faults in the circuit files may be accessed using the password *book* (all lowercase).

23.  $R_4$  shorted

24.  $R_3$  open

25.  $C_3$  shorted

26.  $R_5$  open

- 27.  $R_1$  open
- 28.  $R_2$  shorted
- 29.  $R_1$  open
- 30.  $C_2$  open
- 31.  $R_7$  open

# Chapter 16

## Oscillators

---

### Section 16-1 The Oscillator

1. An oscillator requires no input other than the dc supply voltage.
2. Amplifier and positive feedback circuit

### Section 16-2 Feedback Oscillator Principles

3. Unity gain around the closed loop is required for sustained oscillation.

$$A_{cl} = A_v B = 1$$

$$B = \frac{1}{A_v} = \frac{1}{75} = \mathbf{0.0133}$$

4. To ensure startup:

$$A_{cl} > 1$$

since  $A_v = 75$ ,  $B$  must be greater than  $1/75$  in order to produce the condition  $A_v B > 1$ .

For example, if  $B = 1/50$ ,

$$A_v B = 75 \left( \frac{1}{50} \right) = 1.5$$

### Section 16-3 Oscillators with RC Feedback Circuits

5. 
$$\frac{V_{out}}{V_{in}} = \frac{1}{3}$$
$$V_{out} = \left( \frac{1}{3} \right) V_{in} = \frac{2.2 \text{ V}}{3} = \mathbf{733 \text{ mV}}$$

6. 
$$f_r = \frac{1}{2\pi RC} = \frac{1}{2\pi(6.2 \text{ k}\Omega)(0.02 \text{ }\mu\text{F})} = \mathbf{1.28 \text{ kHz}}$$

7. 
$$R_1 = 2R_2$$
$$R_2 = \frac{R_1}{2} = \frac{100 \text{ k}\Omega}{2} = \mathbf{50 \text{ k}\Omega}$$

8. When dc power is first applied, both zener diodes appear as opens because there is insufficient output voltage. This places  $R_3$  in series with  $R_1$ , thus increasing the closed-loop gain to a value greater than unity to assure that oscillation will begin.

9. 
$$R_f = (A_v - 1)(R_3 + r'_{ds}) = (3 - 1)(820 \text{ }\Omega + 350 \text{ }\Omega) = \mathbf{2.34 \text{ k}\Omega}$$

$$10. \quad f_r = \frac{1}{2\pi(1.0 \text{ k}\Omega)(0.015 \text{ }\mu\text{F})} = \mathbf{10.6 \text{ kHz}}$$

$$11. \quad B = \frac{1}{29}$$

$$A_{cl} = \frac{1}{B} = 29$$

$$A_{cl} = \frac{R_f}{R_i}$$

$$R_f = A_{cl}R_i = 29(4.7 \text{ k}\Omega) = \mathbf{136 \text{ k}\Omega}$$

$$f_r = \frac{1}{2\pi\sqrt{6}((4.7 \text{ k}\Omega)(0.02 \text{ }\mu\text{F}))} = \mathbf{691 \text{ Hz}}$$

### Section 16-4 Oscillators with LC Feedback Circuits

12. (a) *Colpitts*:  $C_1$  and  $C_3$  are the feedback capacitors.

$$f_r = \frac{1}{2\pi\sqrt{L_1 C_T}}$$

$$C_T = \frac{C_1 C_3}{C_1 + C_3} = \frac{(100 \text{ }\mu\text{F})(1000 \text{ pF})}{1100 \text{ pF}} = 90.9 \text{ pF}$$

$$f_r = \frac{1}{2\pi\sqrt{(5 \text{ mH})(90.9 \text{ pF})}} = \mathbf{236 \text{ kHz}}$$

- (b) *Hartley*:

$$f_r = \frac{1}{2\pi\sqrt{L_T C_2}}$$

$$L_T = L_1 + L_2 = 1.5 \text{ mH} + 10 \text{ mH} = 11.5 \text{ mH}$$

$$f_r = \frac{1}{2\pi\sqrt{(11.5 \text{ mH})(470 \text{ pF})}} = \mathbf{68.5 \text{ kHz}}$$

$$13. \quad B = \frac{50 \text{ pF}}{470 \text{ pF}} = 0.106$$

The condition for sustained oscillation is

$$A_v = \frac{1}{B} = \frac{1}{0.106} = \mathbf{9.4}$$

### Section 16-5 Relaxation Oscillators

14. Triangular waveform.

$$f = \frac{1}{4R_1 C} \left( \frac{R_2}{R_3} \right) = \frac{1}{4(22 \text{ k}\Omega)(0.022 \text{ }\mu\text{F})} \left( \frac{56 \text{ k}\Omega}{18 \text{ k}\Omega} \right) = \mathbf{1.61 \text{ kHz}}$$

## Chapter 16

15. Change  $f$  to 10 kHz by changing  $R_1$ :

$$f = \frac{1}{4R_1C} \left( \frac{R_2}{R_3} \right)$$

$$R = \frac{1}{4fC} \left( \frac{R_2}{R_3} \right) = \frac{1}{4(10 \text{ kHz})(0.022 \mu\text{F})} \left( \frac{56 \text{ k}\Omega}{18 \text{ k}\Omega} \right) = 3.54 \text{ k}\Omega$$

16. 
$$T = \frac{V_p - V_F}{\left( \frac{|V_{IN}|}{RC} \right)}$$

$$V_p = \left( \frac{R_5}{R_4 + R_5} \right) 12 \text{ V} = \left( \frac{47 \text{ k}\Omega}{147 \text{ k}\Omega} \right) 12 \text{ V} = 3.84 \text{ V}$$

PUT triggers at about  $+3.84 \text{ V} + 0.7 \text{ V} = 4.54 \text{ V}$

Amplitude =  $+4.54 \text{ V} - 1 \text{ V} = 3.54 \text{ V}$

$$V_{IN} = \left( \frac{R_2}{R_1 + R_2} \right) (-12 \text{ V}) = \left( \frac{22 \text{ k}\Omega}{122 \text{ k}\Omega} \right) (-12 \text{ V}) = -2.16 \text{ V}$$

$$T = \frac{4.54 \text{ V} - 1 \text{ V}}{\left( \frac{2.16 \text{ V}}{(100 \text{ k}\Omega)(0.002 \mu\text{F})} \right)} = 328 \mu\text{s}$$

$$f = \frac{1}{T} = \frac{1}{328 \mu\text{s}} = 3.05 \text{ kHz}$$

See Figure 16-1.

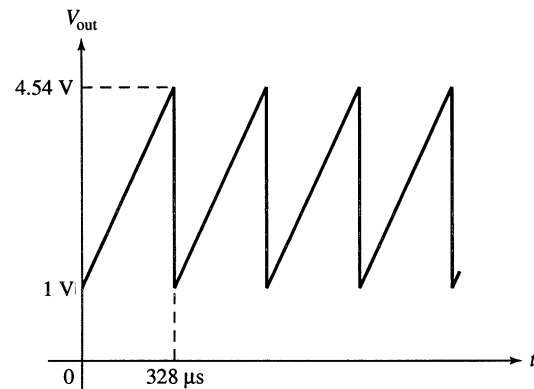

Figure 16-1

17.  $V_G = 5 \text{ V}$ . Assume  $V_{AK} = 1 \text{ V}$ .

$$V_G = \left( \frac{R_5}{R_4 + R_5} \right) 12 \text{ V}$$

Change  $R_4$  to get  $V_G = 5 \text{ V}$ .

$$5 \text{ V}(R_4 + 47 \text{ k}\Omega) = (47 \text{ k}\Omega)12 \text{ V}$$

$$R_4(5 \text{ V}) = (47 \text{ k}\Omega)12 \text{ V} - (47 \text{ k}\Omega)5 \text{ V}$$

$$R_4 = \frac{(12 \text{ V} - 5 \text{ V})47 \text{ k}\Omega}{5 \text{ V}} = 65.8 \text{ k}\Omega$$



$$18. \quad T = \frac{V_p - V_F}{\left(\frac{V_{IN}}{RC}\right)}$$

$$V_p = \left(\frac{V_{IN}}{RC}\right)T + V_F = \left(\frac{3 \text{ V}}{(4.7 \text{ k}\Omega)(0.001 \text{ }\mu\text{F})}\right)10 \text{ }\mu\text{s} + 1 \text{ V} = 7.38 \text{ V}$$

$$V_{pp(out)} = V_p - V_F = 7.38 \text{ V} - 1 \text{ V} = \mathbf{6.38 \text{ V}}$$

### Section 16-6 The 555 Timer as an Oscillator

$$19. \quad \frac{1}{3}V_{CC} = \frac{1}{3}(10 \text{ V}) = \mathbf{3.33 \text{ V}}$$

$$\frac{2}{3}V_{CC} = \frac{2}{3}(10 \text{ V}) = \mathbf{6.67 \text{ V}}$$

$$20. \quad f = \frac{1.44}{(R_1 + 2R_2)C_{ext}} = \frac{1.44}{(1.0 \text{ k}\Omega + 6.6 \text{ k}\Omega)(0.047 \text{ }\mu\text{F})} = \mathbf{4.03 \text{ kHz}}$$

$$21. \quad f = \frac{1.44}{(R_1 + 2R_2)C_{ext}}$$

$$C_{ext} = \frac{1.44}{(R_1 + 2R_2)f} = \frac{1.44}{(1.0 \text{ k}\Omega + 6.6 \text{ k}\Omega)(25 \text{ kHz})} = \mathbf{0.0076 \text{ }\mu\text{F}}$$

$$22. \quad \text{Duty cycle (dc)} = \frac{R_1 + R_2}{R_1 + 2R_2} \times 100\%$$

$$\text{dc}(R_1 + 2R_2) = (R_1 + R_2)100$$

$$75(3.3 \text{ k}\Omega + 2R_2) = (3.3 \text{ k}\Omega + R_2)100$$

$$75(3.3 \text{ k}\Omega + 150R_2) = 100(3.3 \text{ k}\Omega) + 100R_2$$

$$150R_2 - 100R_2 = 100(3.3 \text{ k}\Omega) - 75(3.3 \text{ k}\Omega)$$

$$50R_2 = 25(3.3 \text{ k}\Omega)$$

$$R_2 = \frac{25(3.3 \text{ k}\Omega)}{50} = \mathbf{1.65 \text{ k}\Omega}$$

### EWB/Multisim Troubleshooting Problems

The solutions showing instrument connections for Problems 23 through 28 are available in the Solutions folder for Chapter 16 on the CD-ROM provided with the textbook. The solutions may be accessed using the password *ED5FLOYD*. The faults in the circuit files may be accessed using the password *book* (all lowercase).

- 23. Drain-to-source shorted
- 24.  $C_3$  open
- 25. Collector-to-emitter shorted

## Chapter 16

---

26.  $R_1$  open

27.  $R_2$  open

28.  $R_1$  leaky

# Chapter 17

## Communications Circuits

---

### Section 17-1 Basic Receivers

1. See Figure 17-1.

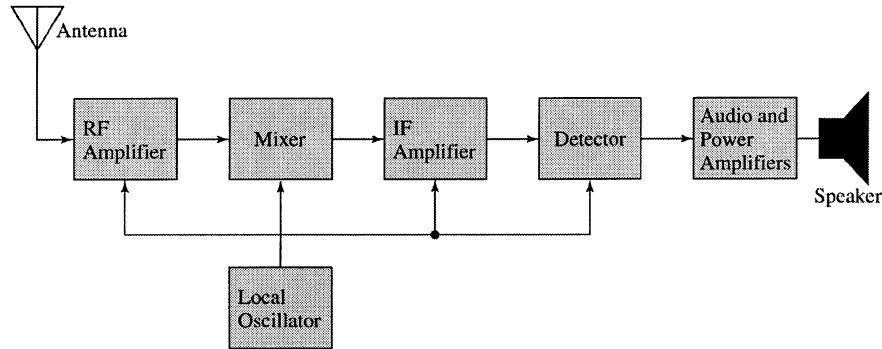

**Figure 17-1**

2. See Figure 17-2.

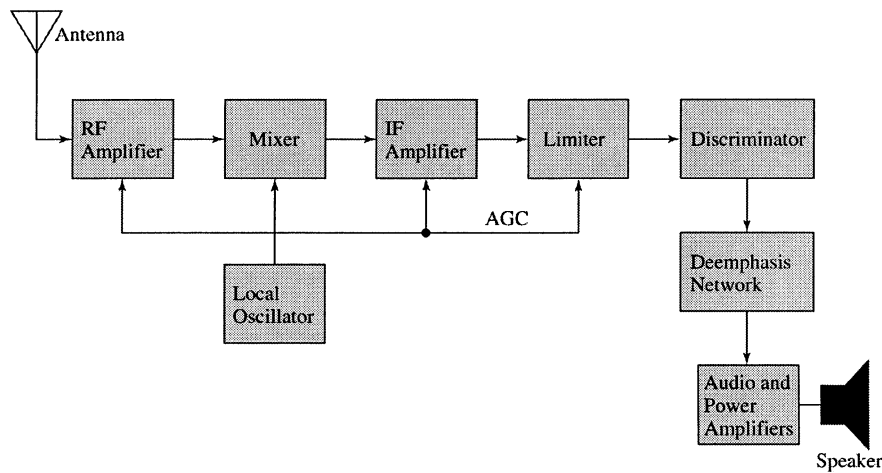

**Figure 17-2**

3.  $f_{LO} = 680 \text{ kHz} + 455 \text{ kHz} = 1135 \text{ kHz}$
4.  $f_{LO} = 97.2 \text{ MHz} + 10.7 \text{ MHz} = 107.9 \text{ MHz}$
5.  $f_{RF} = 101.9 \text{ MHz} - 10.7 \text{ MHz} = 91.2 \text{ MHz}$   
 $f_{IF} = 10.7 \text{ MHz}$  (always)

## Chapter 17

### Section 17-2 The Linear Multiplier

6. (a)  $V_{out} \cong -2.5 \text{ V}$   
(b)  $V_{out} \cong -1.6 \text{ V}$   
(c)  $V_{out} \cong +1.0 \text{ V}$   
(d)  $V_{out} \cong +10 \text{ V}$

7. 
$$I_3 = \frac{|-12 \text{ V}| - 0.7 \text{ V}}{(12 \text{ k}\Omega + 2.8 \text{ k}\Omega) + 500 \Omega} = \frac{11.3 \text{ V}}{15.3 \text{ k}\Omega} = 739 \mu\text{A}$$

8. Using  $I_3$  from Problem 7: 
$$K = \frac{2R_L}{R_X R_Y I_3} = \frac{2(6.8 \text{ k}\Omega)}{(12 \text{ k}\Omega)(12 \text{ k}\Omega)(739 \mu\text{A})} = 0.128$$

9. 
$$V_{out} = KV_X V_Y = 0.8(+3.5 \text{ V})(-2.9 \text{ V}) = -8.12 \text{ V}$$

10. Connect pin 4 to pin 9 and pin 8 to pin 12. Apply the input between pins 9 and 12. For a “true” squaring circuit, the component values must produce a  $K = 1$ .

11. (a)  $V_{out} = KV_1 V_2 = (0.1)(+2 \text{ V})(+1.4 \text{ V}) = +0.28 \text{ V}$   
(b)  $V_{out} = KV_1 V_2 = KV_1^2 (0.1)(-3.2 \text{ V})^2 = +1.024 \text{ V}$   
(c)  $V_{out} = \frac{-V_1}{V_2} = \frac{-(6.2 \text{ V})}{-3 \text{ V}} = +2.07 \text{ V}$   
(d)  $V_{out} = \sqrt{V_1} = \sqrt{6.2 \text{ V}} = +2.49 \text{ V}$

### Section 17-3 Amplitude Modulation

12. 
$$f_{diff} = f_1 - f_2 = 100 \text{ kHz} - 30 \text{ kHz} = 70 \text{ kHz}$$
$$f_{sum} = f_1 + f_2 = 100 \text{ kHz} + 30 \text{ kHz} = 130 \text{ kHz}$$

13. 
$$f_1 = \frac{9 \text{ cycles}}{1 \text{ ms}} = 9000 \text{ cycles/s} = 9 \text{ kHz}$$
$$f_2 = \frac{1 \text{ cycle}}{1 \text{ ms}} = 1000 \text{ cycles/s} = 1 \text{ kHz}$$
$$f_{diff} = f_1 - f_2 = 9 \text{ kHz} - 1 \text{ kHz} = 8 \text{ kHz}$$
$$f_{sum} = f_1 + f_2 = 9 \text{ kHz} + 1 \text{ kHz} = 10 \text{ kHz}$$

14. 
$$f_c = 1000 \text{ kHz}$$
$$f_{diff} = 1000 \text{ kHz} - 3 \text{ kHz} = 997 \text{ kHz}$$
$$f_{sum} = 1000 \text{ kHz} + 3 \text{ kHz} = 1003 \text{ kHz}$$

15.  $f_1 = \frac{18 \text{ cycles}}{10 \mu\text{s}} = 1.8 \text{ MHz}$   
 $f_2 = \frac{1 \text{ cycle}}{10 \mu\text{s}} = 100 \text{ kHz}$   
 $f_{diff} = f_1 - f_2 = 1.8 \text{ MHz} - 100 \text{ kHz} = \mathbf{1.7 \text{ MHz}}$   
 $f_{sum} = f_1 + f_2 = 1.8 \text{ MHz} + 100 \text{ kHz} = \mathbf{1.9 \text{ MHz}}$   
 $f_c = \mathbf{1.8 \text{ MHz}}$
16.  $f_c = 1.2 \text{ MHz}$  by inspection  
 $f_m = f_c - f_{diff} = 1.2 \text{ MHz} - 1.1955 \text{ MHz} = \mathbf{4.5 \text{ kHz}}$
17.  $f_c = \frac{f_{diff} + f_{sum}}{2} = \frac{847 \text{ kHz} + 853 \text{ kHz}}{2} = \mathbf{850 \text{ kHz}}$   
 $f_m = f_c - f_{diff} = 850 \text{ kHz} - 847 \text{ kHz} = \mathbf{3 \text{ kHz}}$
18.  $f_{diff(min)} = 600 \text{ kHz} - 3 \text{ kHz} = \mathbf{597 \text{ kHz}}$   
 $f_{diff(max)} = 600 \text{ kHz} - 300 \text{ Hz} = \mathbf{599.7 \text{ kHz}}$   
 $f_{sum(min)} = 600 \text{ kHz} + 300 \text{ Hz} = \mathbf{600.3 \text{ kHz}}$   
 $f_{sum(max)} = 600 \text{ kHz} + 3 \text{ kHz} = \mathbf{603 \text{ kHz}}$   
 See Figure 17-3.

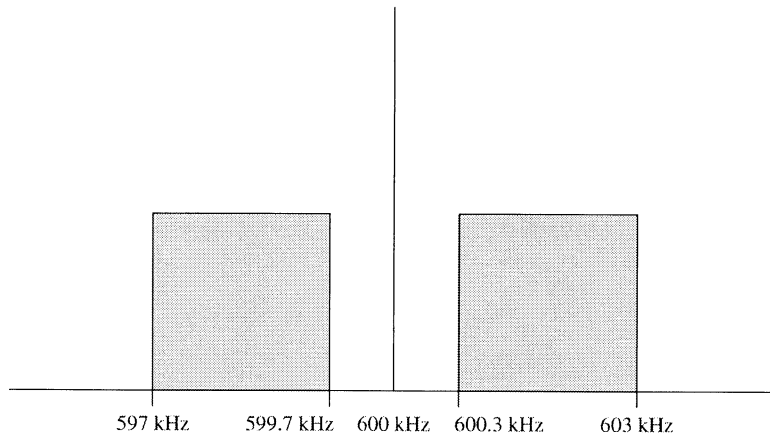

Figure 17-3

### Section 17-4 The Mixer

19.  $(\sin A)(\sin B) = \frac{1}{2}[\cos(A - B) - \cos(A + B)]$   
 $V_{in(1)} = 0.2 \text{ V} \sin [2\pi(2200 \text{ kHz})t]$   
 $V_{in(2)} = 0.15 \text{ V} \sin [2\pi(3300 \text{ kHz})t]$   
 $V_{in(1)}V_{in(2)} = (0.2 \text{ V})(0.15 \text{ V}) \sin [2\pi(2200 \text{ kHz})t] \sin [2\pi(3300 \text{ kHz})t]$   
 $V_{out} = \frac{(0.2 \text{ V})(0.15 \text{ V})}{2} [\cos 2\pi(3300 \text{ kHz} - 2200 \text{ kHz})t - \cos 2\pi(3300 \text{ kHz} + 2200 \text{ kHz})t]$   
 $V_{out} = 15 \text{ mV} \cos [2\pi(1100 \text{ kHz})t] - 15 \text{ mV} \cos [2\pi(5500 \text{ kHz})t]$
20.  $f_{IF} = f_{LO} - f_c = 986.4 \text{ kHz} - 980 \text{ kHz} = \mathbf{6.4 \text{ kHz}}$

# Chapter 17

## Section 17-5 AM Demodulation

21. See Figure 17-4.

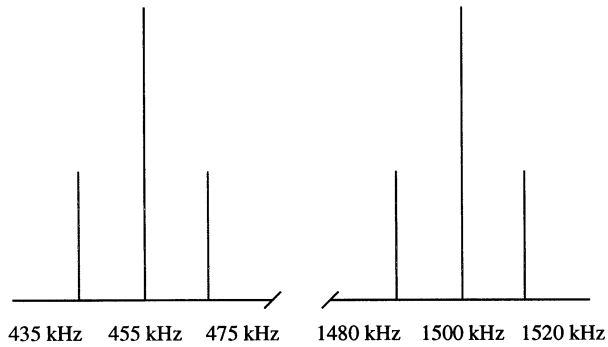

Figure 17-4

22. See Figure 17-5.

23. See Figure 17-6.



Figure 17-5

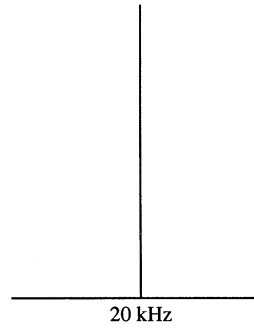

Figure 17-6

## Section 17-6 IF and Audio Amplifiers

24.  $f_c - f_m = 1.2 \text{ MHz} - 8.5 \text{ kHz} = 1.1915 \text{ MHz}$   
 $f_c + f_m = 1.2 \text{ MHz} + 8.5 \text{ kHz} = 1.2085 \text{ MHz}$   
 $f_c = 1.2 \text{ MHz}$   
 $f_{LO} - f_m = 455 \text{ kHz} - 8.5 \text{ kHz} = 446.5 \text{ kHz}$   
 $f_{LO} + f_m = 455 \text{ kHz} + 8.5 \text{ kHz} = 463.5 \text{ kHz}$   
 $f_{LO} = 455 \text{ kHz}$
25. The **IF amplifier** has a 450 kHz to 460 kHz passband.  
The **audio/power amplifiers** have a 10 Hz to 5 kHz bandpass.

26.  $C_4$  between pins 1 and 8 makes the gain 200.  
 With  $R_1$  set for minimum input,  $V_{in} = 0 \text{ V}$ .  
 $V_{out(min)} = A_v V_{in(min)} = 200(0 \text{ V}) = \mathbf{0 \text{ V}}$   
 With  $R_1$  set for maximum input,  $V_{in} = 10 \text{ mV rms}$ .  
 $V_{out(max)} = A_v V_{in(max)} = 200(10 \text{ mV}) = \mathbf{2 \text{ V rms}}$

**Section 17-7 Frequency Modulation**

27. The modulating input signal is applied to the control voltage terminal of the VCO. As the input signal amplitude varies, the output frequency of the VCO varies proportionately.
28. An FM signal differs from an AM signal in that the information is contained in frequency variations of the carrier rather than amplitude variations.
29. Varactor

**Section 17-8 The Phase-Locked Loop (PLL)**

30. See Figure 17-7.

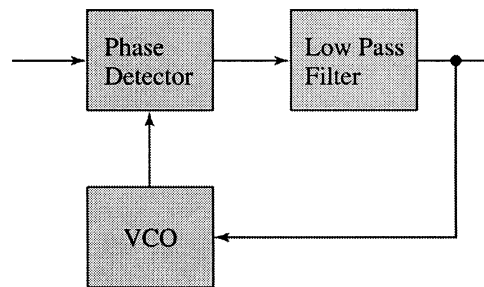

Figure 17-7

31. (a) The VCO signal is locked onto the incoming signal and therefore its frequency is equal to the incoming frequency of **10 MHz**.

(b)  $V_c = \frac{V_i V_o}{2} \cos \theta_e \frac{(250 \text{ mV})(400 \text{ mV})}{2} \cos(30^\circ - 15^\circ) = (0.050)(0.966) = \mathbf{48.3 \text{ mV}}$

32.  $\Delta f_o = +3.6 \text{ kHz}, \quad \Delta V_c = +0.5 \text{ V}$   
 $K = \frac{\Delta f_o}{\Delta V_c} = \frac{+3.6 \text{ kHz}}{+0.5 \text{ V}} = \mathbf{7.2 \text{ kHz/V}}$

33.  $K = 1.5 \text{ kHz/V}, \quad \Delta V_c = +0.67 \text{ V}$   
 $K = \frac{\Delta f_o}{\Delta V_c}$   
 $\Delta f_o = K \Delta V_c = (1.5 \text{ kHz/V})(+0.67 \text{ V}) = \mathbf{1005 \text{ Hz}}$

## Chapter 17

---

34. For a PLL to acquire lock the following conditions are needed:
- (1) The difference frequency,  $f_0 - f_i$  must fall within the filter's bandwidth.
  - (2) The maximum frequency deviation of the VCO frequency,  $\Delta f_{max}$ , must be sufficient to permit  $f_0$  to change to equal  $f_i$ .
35. The free-running frequency:

$$f_o = \frac{1.2}{4R_1C_1} = \frac{1.2}{4(3.9\text{ k}\Omega)(330\text{ pF})} = \mathbf{233\text{ kHz}}$$

The lock range:

$$f_{lock} = \pm \frac{8f_o}{V_{CC}} = \pm \frac{8(233\text{ kHz})}{18\text{ V}} = \pm \frac{1.864\text{ MHz}}{18\text{ V}} = \mathbf{\pm 104\text{ kHz}}$$

The capture range:

$$\begin{aligned} f_{cap} &= \pm \frac{1}{2\pi} \sqrt{\left( \frac{2\pi f_{lock}}{3600 \times C_2} \right)} \\ &= \pm \frac{1}{2\pi} \sqrt{\left( \frac{2\pi(103.6\text{ kHz})}{3600 \times 0.22\ \mu\text{F}} \right)} = \pm \frac{1}{2\pi} \sqrt{\left( \frac{650.9\text{ kHz}}{792\ \mu\text{F}} \right)} = \mathbf{\pm 4.56\text{ kHz}} \end{aligned}$$

There are no *EWB/Multisim* Troubleshooting Problems in this chapter.



# Chapter 18

## Voltage Regulators

---

### Section 18-1 Voltage Regulation

- Percent line regulation =  $\left(\frac{\Delta V_{\text{OUT}}}{\Delta V_{\text{IN}}}\right)100\% = \left(\frac{2 \text{ mV}}{6 \text{ V}}\right)100\% = \mathbf{0.0333\%}$
- Percent line regulation =  $\left(\frac{\Delta V_{\text{OUT}}/V_{\text{OUT}}}{\Delta V_{\text{IN}}}\right)100\% = \left(\frac{2 \text{ mV}/8 \text{ V}}{6 \text{ V}}\right)100\% = \mathbf{0.00417\%/V}$
- Percent load regulation =  $\left(\frac{V_{\text{NL}}/V_{\text{FL}}}{\Delta V_{\text{FL}}}\right)100\% = \left(\frac{10 \text{ V} - 9.90 \text{ V}}{9.90 \text{ V}}\right)100\% = \mathbf{1.01\%}$
- From Problem 3, the percent load regulation is 1.01%. For a full load current of 250 mA, this can be expressed as  

$$\frac{1.01\%}{250 \text{ mA}} = \mathbf{0.00404\%/mA}$$

### Section 18-2 Basic Series Regulators

- See Figure 18-1.

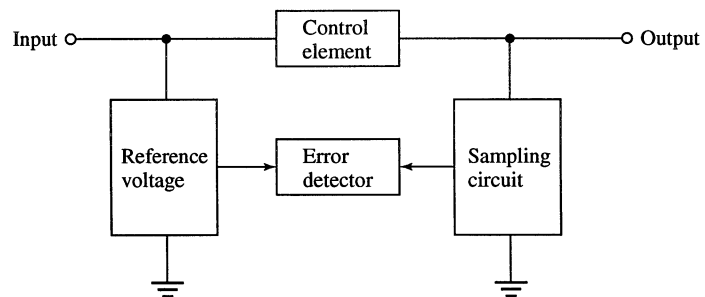

Figure 18-1

- $V_{\text{OUT}} = \left(1 + \frac{R_2}{R_3}\right)V_{\text{REF}} = \left(1 + \frac{33 \text{ k}\Omega}{10 \text{ k}\Omega}\right)2.4 \text{ V} = \mathbf{10.3 \text{ V}}$
- $V_{\text{OUT}} = \left(1 + \frac{R_2}{R_3}\right)V_{\text{REF}} = \left(1 + \frac{5.6 \text{ k}\Omega}{2.2 \text{ k}\Omega}\right)2.4 \text{ V} = \mathbf{8.51 \text{ V}}$

## Chapter 18

---

8. For  $R_3 = 2.2 \text{ k}\Omega$ :

$$V_{\text{OUT}} = \left(1 + \frac{R_2}{R_3}\right) V_{\text{REF}} = \left(1 + \frac{5.6 \text{ k}\Omega}{2.2 \text{ k}\Omega}\right) 2.4 \text{ V} = 8.5 \text{ V}$$

- For  $R_3 = 4.7 \text{ k}\Omega$ :

$$V_{\text{OUT}} = \left(1 + \frac{R_2}{R_3}\right) V_{\text{REF}} = \left(1 + \frac{5.6 \text{ k}\Omega}{4.7 \text{ k}\Omega}\right) 2.4 \text{ V} = 5.23 \text{ V}$$

The output voltage **decreases by 3.27 V** when  $R_3$  is changed from 2.2 k $\Omega$  to 4.7 k $\Omega$ .

9. 
$$V_{\text{OUT}} = \left(1 + \frac{R_2}{R_3}\right) V_{\text{REF}} = \left(1 + \frac{5.6 \text{ k}\Omega}{2.2 \text{ k}\Omega}\right) 2.7 \text{ V} = 9.57 \text{ V}$$

10. 
$$I_{L(\text{max})} = \frac{0.7 \text{ V}}{R_4}$$

$$R_4 = \frac{0.7 \text{ V}}{I_{L(\text{max})}} = \frac{0.7 \text{ mA}}{250 \text{ mA}} = 2.8 \Omega$$

$$P = I_{L(\text{max})}^2 R_4 = (250 \text{ mA})^2 2.8 \Omega = 0.175 \text{ W}, \text{ Use a } 0.25 \text{ W.}$$

11. 
$$R_4 = \frac{2.8 \Omega}{2} = 1.4 \Omega$$

$$I_{L(\text{max})} = \frac{0.7 \text{ V}}{R_4} = \frac{0.7 \text{ V}}{1.4 \Omega} = 500 \text{ mA}$$

### Section 18-3 Basic Shunt Regulators

12.  $Q_1$  conducts more when the load current increases, assuming that the output voltage attempts to increase. When the output voltage tries to increase due to a change in load current, the attempted increase is sensed by  $R_3$  and  $R_4$  and a proportional voltage is applied to the op-amp's noninverting input. The resulting difference voltage increases the op-amp output, driving  $Q_1$  more and thus increasing its collector current.

13. 
$$\Delta I_C = \frac{\Delta V_{R1}}{R_1} = \frac{1 \text{ V}}{100 \Omega} = 10 \text{ mA}$$

14. 
$$V_{\text{OUT}} = \left(1 + \frac{R_3}{R_4}\right) V_{\text{REF}} = \left(1 + \frac{10 \text{ k}\Omega}{3.9 \text{ k}\Omega}\right) 5.1 \text{ V} = 18.2 \text{ V}$$

$$I_{L1} = \frac{V_{\text{OUT}}}{R_{L1}} = \frac{18.2 \text{ V}}{1 \text{ k}\Omega} = 18.2 \text{ mA}$$

$$I_{L2} = \frac{V_{\text{OUT}}}{R_{L2}} = \frac{18.2 \text{ V}}{1.2 \text{ k}\Omega} = 15.2 \text{ mA}$$

$$\Delta I_L = 15.2 \text{ mA} - 18.2 \text{ mA} = -3.0 \text{ mA}$$

$$\Delta I_S = -\Delta I_L = 3.0 \text{ mA}$$

$$15. \quad I_{L(\max)} = \frac{V_{\text{IN}}}{R_1} = \frac{25 \text{ V}}{100 \Omega} = 250 \text{ mA}$$

$$P_{R1} = I_{L(\max)}^2 R_1 = (250 \text{ mA})^2 100 \Omega = 6.25 \text{ W}$$

### Section 18-4 Basic Switching Regulators

$$16. \quad V_{\text{OUT}} = \left( \frac{t_{\text{on}}}{T} \right) V_{\text{IN}}$$

$$t_{\text{on}} = T - t_{\text{off}}$$

$$T = \frac{1}{f} = \frac{1}{100 \text{ Hz}} = 0.01 \text{ s} = 10 \text{ ms}$$

$$V_{\text{OUT}} = \left( \frac{4 \text{ ms}}{10 \text{ ms}} \right) 12 \text{ V} = 4.8 \text{ V}$$

$$17. \quad f = 100 \text{ Hz}, t_{\text{off}} = 6 \text{ ms}$$

$$T = \frac{1}{f} = \frac{1}{100 \text{ Hz}} = 10 \text{ ms}$$

$$t_{\text{on}} = T - t_{\text{off}} = 10 \text{ ms} - 6 \text{ ms} = 4 \text{ ms}$$

$$\text{duty cycle} = \frac{t_{\text{on}}}{T} = \frac{4 \text{ ms}}{10 \text{ ms}} = 0.4$$

$$\text{percent duty cycle} = 0.4 \times 100\% = 40\%$$

18. The diode  $D_1$  becomes forward-biased when  $Q_1$  turns off.
19. The output voltage **decreases**.

### Section 18-5 Integrated Circuit Voltage Regulators

20. (a) 7806: **+6 V**  
 (b) 7905.2: **-5.2 V**  
 (c) 7818: **+18 V**  
 (d) 7924: **-24 V**

$$21. \quad V_{\text{OUT}} = \left( 1 + \frac{R_2}{R_1} \right) V_{\text{REF}} + I_{\text{ADJ}} R_2 = \left( 1 + \frac{10 \text{ k}\Omega}{1.0 \text{ k}\Omega} \right) 1.25 \text{ V} + (50 \mu\text{A})(10 \text{ k}\Omega)$$

$$= 13.7 \text{ V} + 0.5 \text{ V} = 14.3 \text{ V}$$

## Chapter 18

$$22. \quad V_{OUT(min)} = - \left[ \left( 1 + \frac{R_{2(min)}}{R_1} \right) V_{REF} + I_{ADJ} R_{2(min)} \right]$$

$$R_{2(min)} = 0 \, \Omega$$

$$V_{OUT(min)} = - (1.25 \text{ V}(1+0) + 0) = -1.25 \text{ V}$$

$$V_{OUT(max)} = - \left[ \left( 1 + \frac{R_{2(max)}}{R_1} \right) V_{REF} + I_{ADJ} R_{2(max)} \right] = - \left[ 1.25 \text{ V} \left( 1 + \frac{10 \text{ k}\Omega}{470 \, \Omega} \right) + (50 \, \mu\text{A})(10 \text{ k}\Omega) \right]$$

$$= - (1.25 \text{ V}(22.28) + 0.5 \text{ V}) = -28.4 \text{ V}$$

23. The regulator current equals the current through  $R_1 + R_2$ .

$$I_{REG} \cong \frac{V_{OUT}}{R_1 + R_2} = \frac{14.3 \text{ V}}{11 \text{ k}\Omega} = 1.3 \text{ mA}$$

$$24. \quad V_{IN} = 18 \text{ V}, V_{OUT} = 12 \text{ V}$$

$$I_{REG(max)} = 2 \text{ mA}, V_{REF} = 1.25 \text{ V}$$

$$R_1 = \frac{V_{REF}}{I_{REG}} = \frac{1.25 \text{ V}}{2 \text{ mA}} = 625 \, \Omega$$

Neglecting  $I_{ADJ}$ :

$$V_{R2} = 12 \text{ V} - 1.25 \text{ V} = 10.8 \text{ V}$$

$$R_2 = \frac{V_{R2}}{I_{REG}} = \frac{10.8 \text{ V}}{2 \text{ mA}} = 5.4 \text{ k}\Omega$$

For  $R_1$  use  $620 \, \Omega$  and for  $R_2$  use either  $5600 \, \Omega$  or a  $10 \text{ k}\Omega$  potentiometer for precise adjustment to  $12 \text{ V}$ .

### Section 18-6 Applications of IC Voltage Regulators

$$25. \quad V_{R_{ext}(min)} = 0.7 \text{ V}$$

$$R_{ext} = \frac{0.7 \text{ V}}{I_{max}} = \frac{0.7 \text{ V}}{250 \text{ mA}} = 2.8 \, \Omega$$

$$26. \quad V_{OUT} = +12 \text{ V}$$

$$I_L = \frac{12 \text{ V}}{10 \, \Omega} = 1200 \text{ mA} = 1.2 \text{ A}$$

$$I_{ext} = I_L - I_{max} = 1.2 \text{ A} - 0.5 \text{ A} = 0.7 \text{ A}$$

$$P_{ext} = I_{ext}(V_{IN} - V_{OUT}) = 0.7 \text{ A}(15 \text{ V} - 12 \text{ V}) = 0.7 \text{ A}(3 \text{ V}) = 2.1 \text{ W}$$

$$27. \quad V_{R_{lim}(min)} = 0.7 \text{ V}$$

$$R_{lim(min)} = \frac{0.7 \text{ V}}{I_{ext}} = \frac{0.7 \text{ V}}{2 \text{ A}} = 0.35 \, \Omega$$

See Figure 18-2.

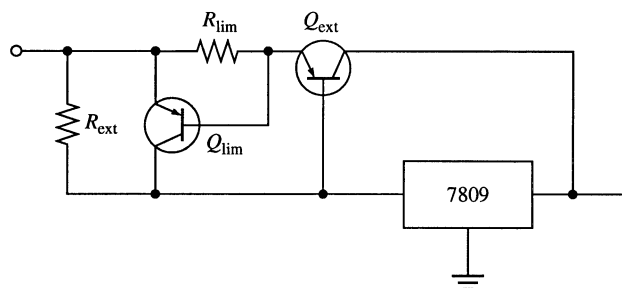
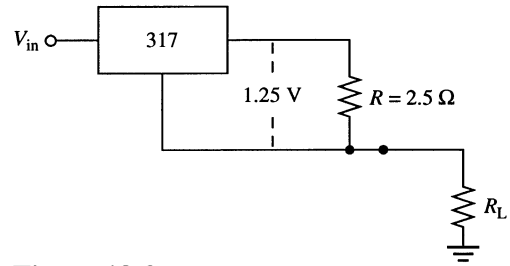

Figure 18-2

28.  $R = \frac{1.25 \text{ V}}{500 \text{ mA}} = 2.5 \Omega$   
See Figure 18-3.



**Figure 18-3**

29.  $R = \frac{8 \text{ V}}{500 \text{ mA}} = 16 \Omega$   
See Figure 18-4.

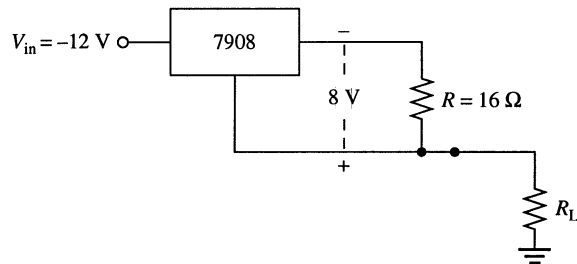

**Figure 18-4**

30.  $V_{\text{REF}} = 1.25 \text{ V}$   
The voltage divider must reduce the output voltage (12 V) down to the reference voltage (1.25 V). See Figure 18-38 in the text.

$$V_{\text{REF}} = \left( \frac{R_1}{R_1 + R_2} \right) V_{\text{OUT}}$$

$$\frac{R_1}{R_1 + R_2} = \frac{V_{\text{REF}}}{V_{\text{OUT}}}$$

$$R_1 = R_1(V_{\text{REF}}/V_{\text{OUT}}) + R_2(V_{\text{REF}}/V_{\text{OUT}})$$

$$R_2 = \frac{R_1 - R_1(V_{\text{REF}}/V_{\text{OUT}})}{(V_{\text{REF}}/V_{\text{OUT}})} = \frac{R_1(1 + V_{\text{REF}}/V_{\text{OUT}})}{(V_{\text{REF}}/V_{\text{OUT}})}$$

Let  $R_1 = 10 \text{ k}\Omega$ .

$$R_2 = \frac{10 \text{ k}\Omega(1 - 1.25 \text{ V}/12 \text{ V})}{(1.25 \text{ V}/12 \text{ V})} = 86 \text{ k}\Omega$$

## Chapter 18

---

### EWB/Multisim Troubleshooting Problems

The solutions showing instrument connections for Problems 31 through 34 are available in the Solutions folder for Chapter 18 on the CD-ROM provided with the textbook. The solutions may be accessed using the password *ED5FLOYD*. The faults in the circuit files may be accessed using the password *book* (all lowercase).

31.  $R_2$  leaky
32. Zener diode open
33.  $Q_2$  collector-to-emitter open
34.  $R_1$  open

# **Results for System Applications**





# Results for System Applications

---

## Chapter 2

### *The Components*

Transformer: 9 V rms

Diode: 1N5400, 1N4719, or MR500

Surge resistor: 1.0  $\Omega$

Fuse: 250 mA slow-blow

Filter Capacitor 6800  $\mu\text{F}$

### *Troubleshooting*

Board 1: Fuse is open

Board 2: Diode open

Board 3: Third diode from top is open

## Chapter 3

### *The Components*

Regulator: 1N4733 5.1 V zener

Limiting resistor: 24  $\Omega$

Series resistors: 36  $\Omega$  for LED, 330 k $\Omega$  for photodiode

Fuse: 250 mA slow-blow

### *Troubleshooting*

Board 1: Photodiode defective

Board 2: Filter capacitor open

Board 3: Zener is open and not regulating

## Chapter 4

### *The Components*

Bias resistors: 1/4 W

$Q_6$  collector resistor: 1 W max (depends on load of time delay circuit)

Relay: 12 V, 55  $\Omega$ , 0.15 A (relay A)

Diode: 1N4002

### *Troubleshooting*

Board 1: CE junction of  $Q_2$  open

Board 2: CE junction of  $Q_3$  open

Board 3:  $R_{12}$  shorted

## Results for System Applications

---

### Chapter 5

#### *Analysis of the Temperature-to-Voltage Conversion Circuit*

At  $T = 46^\circ\text{C}$ :  $V_{\text{OUT}} = 4.78 \text{ V}$

At  $T = 50^\circ\text{C}$ :  $V_{\text{OUT}} = 6.54 \text{ V}$

At  $T = 54^\circ\text{C}$ :  $V_{\text{OUT}} = 7.06 \text{ V}$

The transistor is operating linearly.

#### *The Power Supply Circuit*

Resistors:  $R_1 = 1.0 \Omega$ ,  $R_2 = 6.8 \Omega$ ,  $R_3 = 56 \Omega$

Zener diodes: 1N4739, 9.1 V; 1N4733, 5.1 V. The 9.1 V zener should have a heat sink if there is no guaranteed minimum load.

#### *Troubleshooting*

Board 1: Most likely a 9.1 V zener instead of a 5.1 V has been inserted.

Board 2: Thermistor open

Board 3: CE junction of transistor open

### Chapter 6

#### *Analysis of the Preamplifier Circuit*

Input resistance:  $R_{\text{in}(1)} = 17 \Omega$

Input power:  $P = 362 \mu\text{W}$

DC voltages:

$V_{\text{B}(1)} = 19.3 \text{ V}$ ,  $V_{\text{E}(1)} = 1.23 \text{ V}$ ,  $V_{\text{C}(1)} = 9.29 \text{ V}$

$V_{\text{B}(2)} = 1.88 \text{ V}$ ,  $V_{\text{E}(2)} = 1.18 \text{ V}$ ,  $V_{\text{C}(2)} = 7.54 \text{ V}$

Total voltage gain: Max  $A_v = 733$ , Min  $A_v = 145$

DC current: 2.68 mA

Resistor power ratings: All 1/8 W

Lowest frequency: 935 Hz

#### *The Power Supply Circuit*

To adapt, change to a 12 V zener regulator such as a 1N4742.

#### *Troubleshooting*

Board 1:  $R_6$  is open, causing  $Q_2$  to saturate.

Board 2: Signal input, no signal output. No signal at collector of  $Q_1$ , but dc voltage appears ok.

Most likely fault is open  $C_1$ .

Board 3: Gain of stage 2 is approximately 4, which is much too low.  $C_4$  is open.

## Chapter 7

The schematic for the circuit board is as follows:

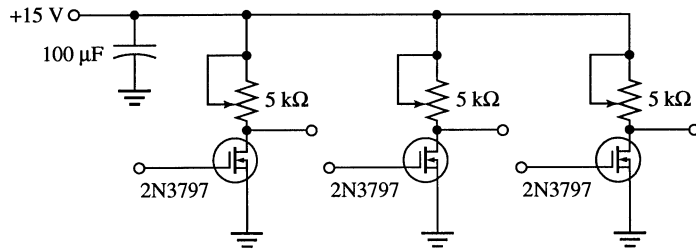

### *Analysis of the pH Sensor Circuits*

*Input resistance:*  $R_{in(min)} = 10 \times 10^{12} \Omega$

*Rheostat:* 4 kΩ maximum, 2.76 kΩ typical, 1.33 kΩ minimum

*Output voltage range:* 5.32 V to 8.52 V represent pH values from about 3.5 to about 9.5.

### *Troubleshooting*

Board 1:  $Q_2$  is probably open although  $R_2$  could be shorted.

Board 2:  $V_{OUT}$  for sensor 2 is too high. The rheostat is probably miscalibrated or  $Q_2$  is faulty.

## Chapter 8

### *Basic MOSFET Amplifier Design*

*Drain-to-source voltage:*  $V_{DS(min)} = 3 \text{ V}$ ,  $V_{DS(max)} = 9 \text{ V}$

*Voltage gain:*  $A_{v(min)} = 2.25$ ,  $A_{v(max)} = 4.50$

Variation in  $I_{DSS}$  from one FET to another will affect the  $Q$ -point of the circuit. Use of voltage-divider bias rather than zero-bias will lessen the dependency of the  $Q$ -point on  $I_{DSS}$ .

Since  $g_m$  varies from one device to another, the voltage gain will also vary. To minimize the influence of  $g_m$ , a swamping source resistor with a value much greater than  $1/g_m$  can be used and the drain resistor adjusted accordingly.

### *Amplifier Performance on the Test Bench*

*Measurement 1:* Variation in  $I_{DSS}$  for  $Q_1$  (larger for set 2)

*Measurement 2:* Variation in  $I_{DSS}$  for  $Q_2$  (larger for set 1)

*Measurement 3:* Variation in  $g_m$  for  $Q_1$  (larger for set 1)

*Measurement 4:* Variation in  $g_m$  for  $Q_2$  (larger for set 2)

*Set 1  $Q_1$ :*  $I_{DSS} = 2.53 \text{ mA}$ ,  $g_m = 2070 \mu\text{S}$

*Set 1  $Q_2$ :*  $I_{DSS} = 4.12 \text{ mA}$ ,  $g_m = 2270 \mu\text{S}$

*Set 2  $Q_1$ :*  $I_{DSS} = 4.87 \text{ mA}$ ,  $g_m = 1700 \mu\text{S}$

*Set 2  $Q_2$ :*  $I_{DSS} = 3.95 \text{ mA}$ ,  $g_m = 2780 \mu\text{S}$

Using FETs with maximum  $g_m$  and typical  $I_{DSS}$ , a FET amplifier with 118 stages is required to achieve the same maximum gain of the bipolar junction amplifier.

# Results for System Applications

---

---

## ***Recommendation***

1. MOSFETs are not feasible replacements for the BJTs in this case.
2. Device variation in parameters make mass production impossible because circuit must be “tweaked” to match the gains, unlike BJTs.
3. Retain the BJT because 118 FET stages are required to match the gain of the two-stage BJT.

## **Chapter 9**

### ***Analysis of the Power Amplifier Circuit***

*Input resistance:*  $R_{in(min)} = 8 \text{ k}\Omega$

*Voltage gain:* 1360 (preamp and power amp combined)

*Transistor power ratings:* Not sufficient without the heat sink.

### ***Troubleshooting***

Board 1: The signal appears at the bases but not at the output. One of the darlington transistors is faulty.

Board 2: There is no signal at either base of the darlington transistors, but the dc voltages are ok, indicating that the bias transistor junctions are not faulty. Since there is a signal through  $C_1$ , there is no obvious fault other than an ac short to ground at both bases, which is unlikely. So, the scope measurements are faulty. Perhaps the probe is not making contact with test points 2 and 4 or something has happened to the scope between step 4 and step 5.

## **Chapter 10**

### ***Analysis of the Amplifier Circuit***

*First stage:*  $f_{cl(in)} = 2.31 \text{ Hz}$ ,  $f_{cl(out)} = 1.37 \text{ Hz}$ ,  $f_{cl(bypass)} = 12.7 \text{ Hz}$ ,  $f_{cl(bypass)}$  is dominant.

*First stage:*  $f_{cu(in)} = 206 \text{ kHz}$ ,  $f_{cu(out)} = 13.7 \text{ MHz}$ ,  $f_{cu(in)}$  is dominant.

*Second stage:*  $f_{cl(in)} = 1.37 \text{ Hz}$ ,  $f_{cl(out)} = 1.08 \text{ Hz}$ ,  $f_{cl(bypass)} = 17.9 \text{ Hz}$ ,  $f_{cl(bypass)}$  is dominant.

*Second stage:*  $f_{cu(in)} = 450 \text{ kHz}$ ,  $f_{cu(out)} = 12 \text{ MHz}$ ,  $f_{cu(in)}$  is dominant.

*Overall lower critical frequency:* 17.9 Hz

*Overall upper critical frequency:* 206 kHz

*Overall bandwidth:* approximately 206 kHz

### ***Frequency Response on the Test Bench***

*Lower critical frequency:* Calculated  $f_{cl} = 17.9 \text{ Hz}$ ,  $T = 55.9 \text{ ms}$ ;

$55.9 \text{ ms}/5.5 \text{ div} = 10.2 \text{ ms/div}$ . Closest setting is 10 ms/div. The actual frequency being measured is  $f_{cl} = 1/(10 \text{ ms/div} \times 5.5 \text{ div}) = 18.2 \text{ Hz}$

*Upper critical frequency:* Calculated  $f_{cu} = 206 \text{ kHz}$ ,  $T = 4.85 \mu\text{s}$ ;

$4.85 \mu\text{s}/5 \text{ div} = 0.97 \mu\text{s/div}$ . Closest setting is 1  $\mu\text{s/div}$ . The actual frequency being measured is  $f_{cu} = 1/(1 \mu\text{s/div} \times 5 \text{ div}) = 200 \text{ kHz}$

## Chapter 11

### *Analysis of the Motor Speed-Control Circuit*

PUT gate voltage of 0 V, assuming forward voltage of 0 V, and the potentiometer set at 25 k $\Omega$ :

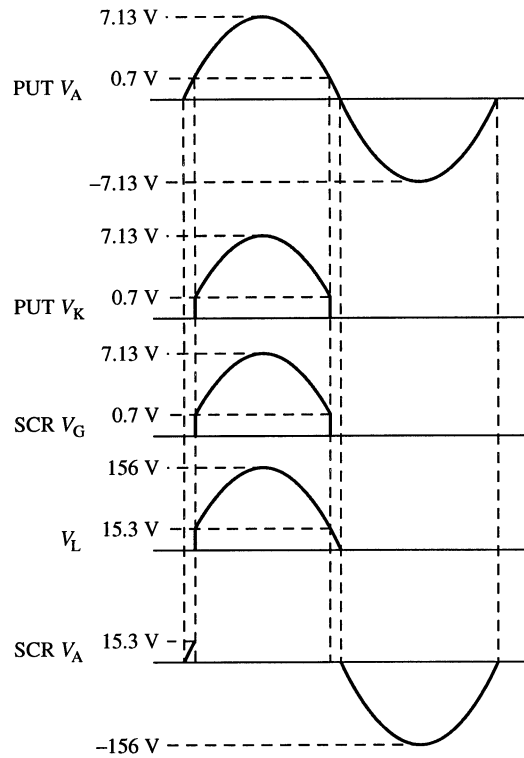

For the potentiometer set to 25 k $\Omega$ ,  $V_A$  of the PUT is the same. With  $V_G = 0$  V, 2 V, 4 V, 6 V, 8 V, and 10 V, the PUT conducts with  $V_A = 0.7$  V, 2.7 V, 4.7 V, 6.7 V, 8.7 V, and 10.7 V respectively. Since  $V_A = 7.13$  V maximum for  $V_G = 8$  V and 10 V, the PUT never conducts and the SCR never fires and the load voltage is zero. The voltages across the load resistor are as follows:

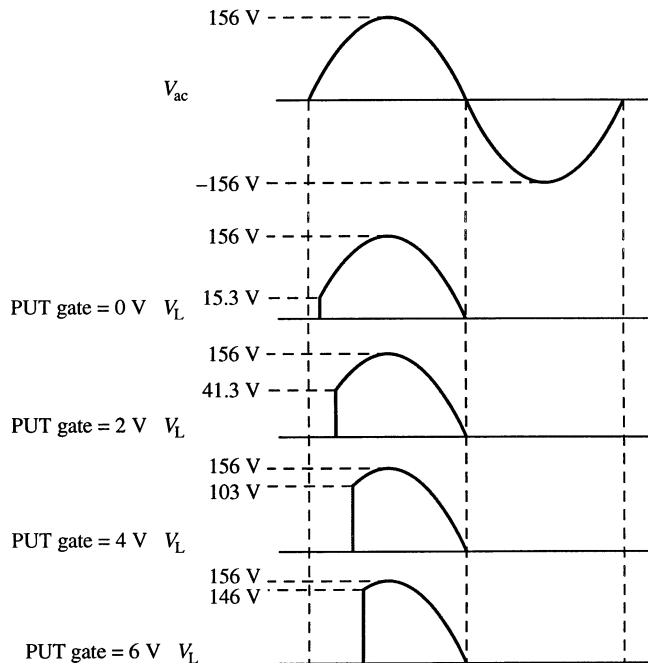

# Results for System Applications

---

## Troubleshooting

- Board 1: The 50 k $\Omega$  resistor is open or the 1.2 k $\Omega$  resistor is shorted.  
Board 2: The SCR is open.  
Board 3: The SCR is shorted.  
Board 4: The PUT is shorted.

## Chapter 12

### Analysis of the Audio Amplifier Circuit

Midrange voltage gain:  $A_{v(\text{mid})} = 46.8$

Lower critical frequency:  $f_{cl} = 15.4$  Hz

Bandwidth:  $BW \cong 15$  kHz

Maximum input:  $V_{in(\text{max})} = 470$  mV peak-to-peak

Speaker power:  $P_{out(\text{max})} = 3.78$  W

## Troubleshooting

- Board 1: The op-amp is faulty, improper connection at pins 3 or 6, or supply not on.  
Board 2:  $R_5$  is open or BE junction of  $Q_1$  is open.  
Board 3:  $R_3$  is open.

## Chapter 13

### Analysis of the ADC Circuit

Summing amplifier gain:  $A_v = -1$

Slope of integrator ramp +2 V input:  $\Delta V_{out}/\Delta t = 2$  V/ $\mu$ s

Slope of integrator ramp -8 V input:  $\Delta V_{out}/\Delta t = -8$  V/ $\mu$ s

Dual-slope output: Positive ramp from 0 V to +3 V in 1  $\mu$ s followed by negative ramp back to 0 V in 0.375  $\mu$ s.

Sampling rate: 571 kHz

## Troubleshooting

- Board 1: IC3 output stuck high.  
Board 2:  $R_1$  or  $R_2$  is open.  
Board 3:  $C_2$  is shorted making IC2 a voltage follower.

## Chapter 14

### The Circuits

Isolation amplifier gain:  $A_{v1} = \frac{R_3}{R_1} + 1 = \frac{330 \text{ k}\Omega}{86 \text{ k}\Omega} = 3.8$ ;  $A_{v2} = \frac{R_5}{R_4} + 1 = \frac{120 \text{ k}\Omega}{100 \text{ k}\Omega} = 1.2$ ;  $A_{v(\text{tot})} = 4.6$

Filter bandwidth:  $\approx 106$  Hz

Filter gain:  $A_v = 1.59$

Post amplifier gain:  $A_{v(\text{min})} = -100$ ,  $A_{v(\text{max})} = -150$

Amplifier gain:  $A_{v(\text{min})} = -1750$ ,  $A_{v(\text{max})} = -2620$

Voltage range at position pot wiper:  $V_{\text{min}} = -59.7$  mV,  $V_{\text{max}} = +59.7$  mV

### ***Troubleshooting***

Board 1: Several faults can product no output including  $R_{10}$  open or IC3 output faulty or open.

Board 2:  $R_6$  or  $R_7$  open.

Board 3:  $R_{10}$  open.

Board 4:  $R_{15}$  or  $R_{16}$  open.

## **Chapter 15**

### ***The Filter Circuit***

*Sallen-Key critical frequencies:* IC1 filter, 15.9 kHz; IC2 filter, 53 kHz; IC4 filter, 18.9 kHz; IC5 filter, 15.9 kHz

*Multiple FB center frequency:* 19 kHz

*Bandwidths:* Approximately the same as the critical frequency for each filter.

*Sallen-Key voltage gains:* IC1 filter, 1.59; IC2 filter, 1.59; IC3 filter, 0.915; IC4 filter, 1.59; IC5 filter 1.59

*Sallen-key response:*  $R_1/R_2 = 0.589$  (approximately Butterworth)

## **Chapter 16**

### ***The Function Generator Circuit***

*Oscillator frequencies:*

×1,: minimum  $f = 0.73$  Hz, Maximum  $f = 8.84$  Hz

×10,: minimum  $f = 7.3$  Hz, Maximum  $f = 88.4$  Hz

×100,: minimum  $f = 73$  Hz, Maximum  $f = 884$  Hz

×1k,: minimum  $f = 730$  Hz, Maximum  $f = 8.84$  Hz

×10k,: minimum  $f = 7.3$  kHz, Maximum  $f = 88.4$  kHz

*Output voltages:*

Sine wave: 25.4 V pp

Square wave: 30 V pp

Triangular wave: 12.6 V pp

### ***Troubleshooting***

Unit 1: Fault is in the IC1 Wien-bridge oscillator block. IC1 output could be open or lead-lag feedback loop open.

Unit 2: Output of IC2 is open.

Unit 3: Output of IC3 open or  $R_7$  or  $R_{10}$  open.

Unit 4: Negative feedback path of IC3 is open causing it to saturate.

## **Chapter 17**

### ***The PC Board***

During board assembly, a “stuffing error” has resulted in a resistor where diode  $D_1$  should be.

### ***The Circuits***

■ Originate mode:  $f_{orig(PLL)} = \frac{1.2}{4R_1C_1} = \frac{1.2}{4(5.6 \text{ k}\Omega)(0.05 \text{ }\mu\text{F})} = 1.07 \text{ kHz}$

Answer mode:  $R_1 = R_3 \parallel R_4 = 6.2 \text{ k}\Omega \parallel 5.6 \text{ k}\Omega = 2.94 \text{ k}\Omega$  (Neglecting  $Q_2$  sat  $R$ )

$$f_{ans(PLL)} \cong \frac{1.2}{4R_1C_1} = \frac{1.2}{4(2.94 \text{ k}\Omega)(0.05 \text{ }\mu\text{F})} = 2.04 \text{ kHz}$$

## Results for System Applications

---

- Same calculations as above:  $f_{orig(VCO)} \cong 1.07 \text{ kHz}$ ,  $f_{ans(VCO)} \cong 2.04 \text{ kHz}$
- Max and min voltages are nearly equal to the supply voltage +6 V and -6 V.
- When  $Q_4$  is off and  $R_{11} = 0 \Omega$  and  $R_8$  set for maximum voltage:  $V_9 = +6 \text{ V}$

$$\text{■ } T = \frac{1}{300 \text{ Hz}} = 3.33 \text{ ms}, \quad \frac{T}{2} = 1.67 \text{ ms}$$

FSK data: 1090 Hz tone for 1.67 ms when pin 9 is low and 1270 Hz tone for 1.67 ms when pin 9 is high.

$$\text{■ } \Delta f = 1270 \text{ Hz} - 1070 \text{ Hz} = 2225 \text{ Hz} - 2025 \text{ Hz} = 200 \text{ Hz}$$

$$V = \frac{200 \text{ Hz}}{50 \text{ Hz/V}} = +4 \text{ V}$$

### ***Troubleshooting***

- No circuit power, frequency components out of tolerance preventing lock, faulty PLL or op-amp.
- $Q_2$ ,  $R_2$ , or  $R_3$  open,  $Q_1$  shorted, faulty PLL.
- VCO faulty,  $C_3$  open.
- $Q_3$  or  $R_6$  open, pin 9 or VCO shorted to ground,  $Q_4$  shorted.

## **Chapter 18**

### ***The Power Supply Circuit***

*Bridge voltages at peak of input:* Top corner:  $\approx 17 \text{ V}$  peak, bottom corner:  $\approx -17 \text{ V}$  peak, left corner:  $-16.3 \text{ V}$  peak, right corner  $+16.3$  peak.

*PIV:* 33.2 V

*Regulator input voltages:* 7812: +16.3 V; 7912: -16.3 V

*Regulator current:* 250 mA from each regulator. Heat sinks are not necessary.

### ***Troubleshooting***

Board 1: Fuse may be blown. Transformer may have an open primary or secondary winding or a shorted primary winding.

Board 2: Input or output of IC1 may be open. Pin 2 of IC1 may be open.  $C_1$  or  $C_3$  may be shorted.

Board 3: Input or output or pin 2 of IC2 may be open.  $C_2$  or  $C_4$  may be shorted.

Board 4: IC1 and IC2 may be swapped.



# **Summary of EWB/Multisim Circuit Files**

**Password for Solution Files: ED5FLOYD**

**Password for Fault Circuits: book**

**Prepared by Gary Snyder**

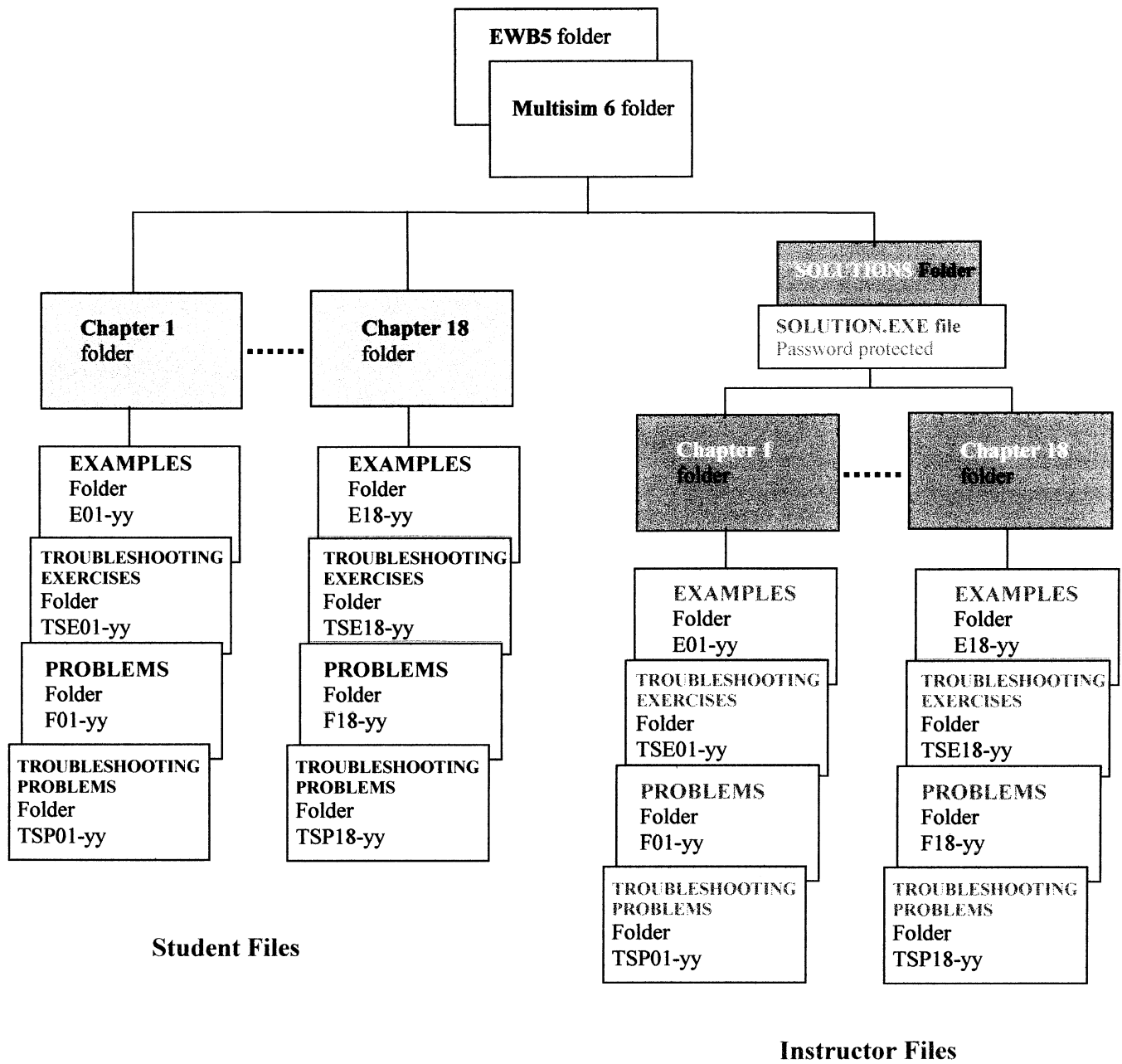

### CD-ROM Organization Diagram

## Summary of Circuit Files

### Chapter 1:

Circuit	EWB	MultiSim
E01-01	$V_R(1) = 9.287 \text{ V}$ $V_D(1) = 712.8 \text{ mV}$ $V_R(2) = 9.98 \text{ mV}$ $V_D(2) = 9.99 \text{ V}$	$V_R(1) = 9.287 \text{ V}$ $V_D(1) = 0.713 \text{ V}$ $V_R(2) = 9.980 \text{ mV}$ $V_D(2) = 9.99 \text{ V}$
F01-41a	$V_R = 0.000 \text{ } \mu\text{V}$	$V_R = 0.020 \text{ nV}$
F01-41b	$V_R = 99.15 \text{ V}$	$V_R = 99.151 \text{ V}$
F01-41c	$V_R = 23.68 \text{ V}$	$V_R = 23.681 \text{ V}$
F01-41d	$V_D = 651.5 \text{ mV}$	$V_D = 0.651 \text{ V}$
F01-42a	$V_D = 25.00 \text{ V}$	$V_D = 25.000 \text{ V}$
F01-42b	$V_D = 15.00 \text{ V}$	$V_D = 15.000 \text{ V}$
F01-42c	$V_D = 2.500 \text{ V}$	$V_D = 2.500 \text{ V}$
F01-42d	$V_R = 0.0113 \text{ } \mu\text{V}$	$V_R = 11.285 \text{ nV}$
F01-43	$V_A = 25.00 \text{ V}$ $V_B = 24.25 \text{ V}$ $V_C = 8.746 \text{ V}$ $V_D = 8.000 \text{ V}$	$V_A = 25.00 \text{ V}$ $V_B = 24.255 \text{ V}$ $V_C = 8.746 \text{ V}$ $V_D = 8.000 \text{ V}$
TSP01-20	$V_R = 3.000 \text{ V}$	$V_R = 3.000 \text{ V}$
TSP01-21	$V_D = 100.0 \text{ V}$	$V_D = 99.994 \text{ V}$
TSP01-22	$V_D = 32.43 \text{ V}$	$V_D = 32.434 \text{ V}$
TSP01-23	$V_D = -0.001 \text{ } \mu\text{V}$	$V_D = -1.000 \text{ pV}$
TSP01-24	$V_D = 667.6 \text{ mV}$	$V_D = 0.668 \text{ V}$
TSP01-25	$V_D = 0.192 \text{ } \mu\text{V}$	$V_D = 0.192 \text{ nV}$
TSP01-26	$V_D = 2.577 \text{ V}$	$V_D = 2.577 \text{ V}$
TSP01-27	$V_D = 11.99 \text{ V}$	$V_D = 11.994 \text{ V}$
TSP01-28	$V_A = 25.00 \text{ V}$ $V_B = 24.25 \text{ V}$ $V_C = 8.000 \text{ V}$ $V_D = 8.000 \text{ V}$	$V_A = 25.00 \text{ V}$ $V_B = 24.253 \text{ V}$ $V_C = 8.000 \text{ V}$ $V_D = 8.000 \text{ V}$

### Chapter 2:

Circuit	EWB	MultiSim
E02-02a	Half-wave $V_p = 4.2115 \text{ V}$	Half-wave $V_p = 4.3 \text{ V}$
E02-02b	Half-wave $V_p = 98.0893 \text{ V}$	Half-wave $V_p = 99.2 \text{ V}$
E02-03	Half-wave $V_p = 76.9264 \text{ V}$	Half-wave $V_p = 77.0 \text{ V}$
E02-05a	Full-wave $V_p = 24.2233 \text{ V}$	Full-wave $V_p = 24.3 \text{ V}$
E02-05b	Full-wave $V_p = 24.2233 \text{ V}$	Full-wave $V_p = 24.3 \text{ V}$
E02-06	Full-wave $V_p = 41.2853 \text{ V}$	Full-wave $V_p = 41.0 \text{ V}$
E02-07	$V_L(\text{max}) = 14.6294 \text{ V}$ $V_L(\text{min}) = 13.8651 \text{ V}$	$V_L(\text{max}) = 14.7 \text{ V}$ $V_L(\text{min}) = 13.8 \text{ V}$
E02-09	Half-wave $V_p(\text{max}) = 8.9581 \text{ V}$ $V_p(\text{min}) = 8.9581 \text{ V}$	Half-wave $V_p(\text{max}) = 9.1 \text{ V}$ $V_p(\text{min}) = 779.1 \text{ mV}$
E02-10	Clipped $V_p(\text{max}) = 5.7492 \text{ V}$ $V_p(\text{min}) = -5.7469 \text{ V}$	Clipped $V_p(\text{max}) = 5.7 \text{ V}$ $V_p(\text{min}) = -5.7 \text{ V}$
E02-11	Clipped $V_p(\text{max}) = 8.9729 \text{ V}$ $V_p(\text{min}) = -17.8942 \text{ V}$	Clipped $V_p(\text{max}) = 9.0 \text{ V}$ $V_p(\text{min}) = -18.0 \text{ V}$
E02-12	Negative Clamp $V_p(\text{max}) = 609.2934 \text{ mV}$ $V_p(\text{min}) = -46.7967 \text{ V}$	Negative Clamp $V_p(\text{max}) = 729 \text{ mV}$ $V_p(\text{min}) = -45.5 \text{ V}$
F02-71a	Half-wave $V_p = 4.1826 \text{ V}$	Half-wave $V_p = 4.2 \text{ V}$

F02-71b	Half-wave $V_p = -49.0255$ V	Half-wave $V_p = -49.3$ V
F02-72	Half-wave $V_p = 78.9313$ V	Half-wave $V_p = 80.5$ V
F02-74	Full-wave $V_p = 19.4361$ V	Full-wave $V_p = 19.6$ V
F02-75	Full-wave $V_p = 29.2363$ V	Full-wave $V_p = 29.5$ V
F02-76	$V_L(\text{max}) = 47.4164$ V $V_L(\text{min}) = 46.6476$ V	$V_L(\text{max}) = 47.6$ V $V_L(\text{min}) = 46.6$ V
F02-77	Half-wave $V_p(\text{max}) = 712.1375$ mV $V_p(\text{min}) = -9.8960$ V	Half-wave $V_p(\text{max}) = 712.7$ mV $V_p(\text{min}) = -10.0$ V
F02-81a	Clipped $V_p(\text{max}) = 721.5138$ mV $V_p(\text{min}) = -722.2388$ mV	Clipped $V_p(\text{max}) = 721.9$ mV $V_p(\text{min}) = -722.0$ mV
F02-81b	Clipped $V_p(\text{max}) = 721.9223$ mV $V_p(\text{min}) = -722.2338$ mV	Clipped $V_p(\text{max}) = 722.0$ mV $V_p(\text{min}) = -722.0$ mV
F02-84	$V_{\text{SEC}} = 114.7$ V <sub>AC</sub> $V_{\text{REC}} = \sim 0$ V $V_L = 59.91$ V	$V_{\text{SEC}} = 117.66$ V <sub>AC</sub> $V_{\text{REC}} = 4.969$ V $V_L = 58.449$ V
F02-86	Full-wave $V_p = 15.4930$ V	Full-wave $V_p = 15.5$ V
TSE02-01	$V_{\text{FUSE}} = 0$ V	$V_{\text{FUSE}} = 0$ V
TSE02-02	$V_{\text{SURGE}} = 0$ V	$V_{\text{SURGE}} = 0$ V
TSE02-03	$V_L(\text{max}) = 21.1824$ V $V_L(\text{min}) = 20.0721$ V	Not implemented
TSP02-48	Unrectified AC $9.9124$ V <sub>pp</sub>	Unrectified AC $10.0$ V <sub>pp</sub>
TSP02-49	$V_L(\text{max}) = 38.0269$ V $V_L(\text{min}) = -48.8304$ V	$V_L(\text{max}) = 38.4$ V $V_L(\text{min}) = -49.3$ V
TSP02-50	$V_L = 0$ V	$V_L = 0$ V
TSP02-51	Half-wave $V_p = 18.5137$ V	Half-wave $V_p = 19.6$ V
TSP02-52	Clipped Full-wave $V_p(\text{max}) = 59.8993$ V $V_p(\text{min}) = \text{Variable}$	Clipped Full-wave $V_p(\text{max}) = 59.8$ V $V_p(\text{min}) = 1.6$ V
TSP02-53	Full-wave $V_p(\text{max}) = 48.8389$ V $V_p(\text{min}) = 1.8545$ V	Full-wave $V_p(\text{max}) = 49.1$ V $V_p(\text{min}) = 784.1$ mV
TSP02-54	Positive Clipped $V_p(\text{max}) = 678.1462$ mV $V_p(\text{min}) = -896.6640$ mV	Positive Clipped $V_p(\text{max}) = 679.1$ mV $V_p(\text{min}) = -909.1$ mV
TSP02-55	Half-wave $V_p(\text{min}) = -29.4365$ V	Half-wave $V_p(\text{min}) = -30.0$ V
TSP02-56	Half-wave $V_p(\text{max}) = 15.8707$ mV $V_p(\text{min}) = \text{Variable}$	Half-wave $V_p(\text{max}) = 16.0$ V $V_p(\text{min}) = 480.1$ mV

### Chapter 3:

Circuit	EWB	MultiSim
E03-05	$I_D(1) = 4.441$ $\mu$ A $V_D(1) = 4.860$ V $I_D(2) = 193.1$ mA $V_D(2) = 6.385$ V	$I_D(1) = 4.749$ $\mu$ A $V_D(1) = 4.860$ V $I_D(2) = 206$ mA $V_D(2) = 5.137$ V
E03-06	$I_D = 1.329$ mA $V_R = 23.45$ mA $V_D = 11.93$ V	$I_D = 1.330$ mA $V_R = 24$ mA $V_D = 11.93$ V
E03-08	Clipped $V_p(\text{max})(1) = 5.6034$ V $V_p(\text{min})(1) = -3.7857$ V $V_p(\text{max})(2) = 6.7324$ V $V_p(\text{min})(2) = -15.5693$ V	Clipped $V_p(\text{max})(1) = 5.6$ V $V_p(\text{min})(1) = -3.8$ V $V_p(\text{max})(2) = 6.7$ V $V_p(\text{min})(2) = -15.5$ V

F03-61	$I_R(1) = 150.4 \text{ mA}$ $V_R(1) = 4.692 \text{ V}$ $I_R(1) = 44.9 \text{ mA}$ $V_R(1) = 5.776 \text{ V}$	$I_R(1) = 150 \text{ mA}$ $V_R(1) = 4.692 \text{ V}$ $I_R(1) = 40 \text{ mA}$ $V_R(1) = 5.116 \text{ V}$
F03-64	$I_D = 34.20 \text{ mA}$	$I_D = 34 \text{ mA}$
F03-68	$V_{OUT} = 12.0272 \text{ V}_{DC}$	$V_{OUT} = 11.002 \text{ V}_{DC}$
TSE03-01	$V_{OUT} = 22.91 \text{ V}_{DC}$	$V_{OUT} =$
TSE03-02	$V_C = 0 \text{ V}_{DC}$ $V_{OUT} = 0 \text{ V}_{DC}$	$V_C = 0 \text{ V}_{DC}$ $V_{OUT} = 0.000 \text{ V}_{DC}$
TSE03-03	$V_D = 15.3620 \text{ V}_{DC}$ with ripple $V_{OUT} = 15.31 \text{ V}_{DC}$	$V_D = 15.0 \text{ V}_{DC}$ with ripple $V_{OUT} = 15.0 \text{ V}_{DC}$
TSE03-04	$V_D = 0 \text{ V}$ Blown fuse	$V_D = 0 \text{ V}$ Blown fuse
TSP03-45	$V_{OUT} = 8.000 \text{ V}_{DC}$	$V_{OUT} = 8.000 \text{ V}_{DC}$
TSP03-46	Spikey Output $V_{OUT} = 12.0800 \text{ V}$ $V_{SPIKE} = 2.1937 \text{ V}$	Spikey Output $V_{OUT} = 12.0 \text{ V}$ $V_{SPIKE} = 9.0 \text{ V}$
TSP03-47	$V_R = 30.66 \text{ V}_{DC}$ $V_{OUT} = 0.093 \mu\text{V}_{DC}$	$V_R > 26 \text{ V}_{DC}$ $V_{OUT} = 0.079 \text{ nV}_{DC}$
TSP03-48	$V_R = 23.44 \text{ V}$	$V_R = 22.243 \text{ V}$

#### Chapter 4:

Circuit	EWB	MultiSim
E04-02	$I_B = 411.9 \mu\text{A}$ $I_C = 61.69 \text{ mA}$ $I_E = 62.50 \text{ mA}$ $V_{CB} = 2.940 \text{ V}$ $V_{CE} = 3.821 \text{ V}$	$I_B = 412 \mu\text{A}$ $I_C = 62 \text{ mA}$ $I_E = 62 \text{ mA}$ $V_{CB} = 2.94 \text{ V}$ $V_{CE} = 3.821 \text{ V}$
E04-04	$I_B = 216.7 \mu\text{A}$ $I_C = 9.838 \text{ mA}$ LED blinks	$I_B = 217 \mu\text{A}$ $I_C = 9.838 \text{ mA}$ LED blinks
E04-10	$I_C(1) = 15.76 \text{ mA}$ $V_{CE}(1) = 4.129 \text{ V}$ $I_C(2) = 14.88 \text{ mA}$ $V_{CE}(2) = 4.375 \text{ V}$	$I_C(1) = 16 \text{ mA}$ $V_{CE}(1) = 2.952 \text{ V}$ $I_C(2) = 13 \text{ mA}$ $V_{CE}(2) = 3.709 \text{ V}$
F04-30	$V_C = 8.986 \text{ V}$ $V_B = 0.612 \text{ V}$	$V_C = 8.986 \text{ V}$ $V_B = 0.612 \text{ V}$
F04-46	$I_B = 667.2 \mu\text{A}$ $I_C = 32.29 \text{ mA}$ $I_E = 32.96 \text{ mA}$	$I_B = 667 \mu\text{A}$ $I_C = 32 \text{ mA}$ $I_E = 33 \text{ mA}$
F04-47a	$V_{BC} = -4.608 \text{ V}$ $V_{BE} = 976.8 \text{ mV}$ $V_{CE} = 5.485 \text{ V}$	$V_{BC} = -4.608 \text{ V}$ $V_{BE} = 877 \text{ mV}$ $V_{CE} = 5.458 \text{ V}$
F04-47b	$V_{BC} = 3.254 \text{ V}$ $V_{BE} = -833.8 \text{ mV}$ $V_{CE} = -4.088 \text{ V}$	$V_{BC} = 3.254 \text{ V}$ $V_{BE} = -0.834 \text{ mV}$ $V_{CE} = -4.088 \text{ V}$
F04-48	$I_B = 24.42 \mu\text{A}$ $I_C = 1.197 \text{ mA}$ $I_E = 1.221 \text{ mA}$	$I_B = 24 \mu\text{A}$ $I_C = 1.197 \text{ mA}$ $I_E = 1.221 \text{ mA}$
F04-49	$V_B(1) = 10.00 \text{ V}$ $V_C(1) = 20.00 \text{ V}$ $V_E(1) = 9.228 \text{ V}$ $V_B(2) = -4.00 \text{ V}$ $V_C(2) = -12.00 \text{ V}$ $V_E(2) = -3.216 \text{ V}$	$V_B(1) = 10.000 \text{ V}$ $V_C(1) = 20.000 \text{ V}$ $V_E(1) = 9.228 \text{ V}$ $V_B(2) = -4.000 \text{ V}$ $V_C(2) = -12.000 \text{ V}$ $V_E(2) = -3.216 \text{ V}$
F04-50	$V_C = 221.6 \text{ mV}$	$V_C = 222 \text{ mV}$

F04-51	$V_B = 838.6 \text{ mV}$ $V_C = 533.8 \text{ mV}$	$V_B = 839 \text{ mV}$ $V_C = 534 \text{ mV}$
TSE04-01	$V_B = 778.5 \text{ mV}$ $V_C = 4.917 \text{ V}$	$V_B = 779 \text{ mV}$ $V_C = 4.917 \text{ V}$
TSE04-02	$V_B = 680.0 \text{ mV}$ $V_C = 5.838 \text{ mV}$	$V_B = 680 \text{ mV}$ $V_C = 5.838 \text{ mV}$
TSE04-03	$V_B = 2.841 \text{ V}$ $V_C = 8.995 \text{ V}$	$V_B = 2.841 \text{ V}$ $V_C = 8.995 \text{ V}$
TSP04-47	$V_{RB} = 2.647 \text{ V}$	$V_{RB} = 2.471 \text{ V}$
TSP04-48	$V_{RC} = 14.98 \text{ V}$	$V_{RC} = 14.982 \text{ V}$
TSP04-49	$V_{CE} = -849.4 \text{ mV}$	$V_{CE} = -0.849 \text{ mV}$
TSP04-50	$V_{CE} = 10.00 \text{ V}$	$V_{CE} = 10.0 \text{ V}$
TSP04-51	$V_B = 10.00 \text{ V}$ $V_C = 20.00 \text{ V}$ $I_C = 91.09 \text{ mA}$	$V_B = 10.00 \text{ V}$ $V_C = 20.00 \text{ V}$ $I_C = 91 \text{ mA}$
TSP0452	$I_C = 5.455 \text{ mA}$	$I_C = 5.456 \text{ mA}$
TSP04-53	$I_B = 0.000 \mu\text{A}$ $V_C = 4.999 \text{ V}$	$I_B = 0.444 \text{ pA}$ $V_C = 4.999 \text{ V}$
TSP04-54	$I_B = 4.350 \mu\text{A}$ $I_C = 0.000 \mu\text{A}$	$I_B = 4.350 \mu\text{A}$ $I_C = -0.021 \text{ pA}$

#### Chapter 5:

Circuit	EWB	MultiSim
E05-01	$V_{BE} = 869.1 \text{ mV}$ $V_{CE} = 7.187 \text{ V}$ $I_C = 38.85 \text{ mA}$	$V_{BE} = 869 \text{ mV}$ $V_{CE} = 7.187 \text{ V}$ $I_C = 39 \text{ mA}$
E05-03	$V_{BE} = 816.0 \text{ mV}$ $V_{CE} = 2.775 \text{ V}$ $I_C = 4.615 \text{ mA}$	$V_{BE} = 814 \text{ mV}$ $V_{CE} = 2.775 \text{ V}$ $I_C = 4.615 \text{ mA}$
E05-04	$V_{BE} = -794.1 \text{ mV}$ $V_{CE} = -3.082 \text{ V}$ $I_C = 2.155 \text{ mA}$	$V_{BE} = -794 \text{ mV}$ $V_{CE} = -3.082 \text{ V}$ $I_C = 2.155 \text{ mA}$
E05-06a	$V_{BE} = 832.4 \text{ mV}$ $V_{CE} = 6.685 \text{ V}$ $I_C = 9.492 \text{ mA}$	$V_{BE} = 832 \text{ mV}$ $V_{CE} = 6.685 \text{ V}$ $I_C = 9.492 \text{ mA}$
E05-06b	$V_{BE} = 836.6 \text{ mV}$ $V_{CE} = 5.749 \text{ V}$ $I_C = 11.16 \text{ mA}$	$V_{BE} = 837 \text{ mV}$ $V_{CE} = 5.749 \text{ V}$ $I_C = 11 \text{ mA}$
E05-08	$V_{BE} = 769.0 \text{ mV}$ $V_{CE} = 1.731 \text{ V}$ $I_C = 826.9 \mu\text{A}$	$V_{BE} = 769 \text{ mV}$ $V_{CE} = 1.731 \text{ V}$ $I_C = 827 \mu\text{A}$
F05-37	$V_{CE} = 10.77 \text{ V}$ $I_C = 922.9 \mu\text{A}$	$V_{CE} = 10.771 \text{ V}$ $I_C = 923 \mu\text{A}$
F05-38	$V_{CE} = 6.001 \text{ V}$ $I_C = 5.126 \text{ mA}$	$V_{CE} = 6.001 \text{ V}$ $I_C = 5.126 \text{ mA}$
F05-40	$V_B = 2.047 \text{ V}$ $V_C = 6.237 \text{ V}$ $V_E = 1.267 \text{ V}$	$V_B = 2.047 \text{ V}$ $V_C = 6.237 \text{ V}$ $V_E = 1.267 \text{ V}$
F05-41	$V_B = -1.666 \text{ V}$ $V_C = -9.197 \text{ V}$ $V_E = -880.61 \text{ mV}$	$V_B = -1.666 \text{ V}$ $V_C = -9.197 \text{ V}$ $V_E = -0.881 \text{ V}$
F05-44	$V_{BE} = -845.8 \text{ mV}$ $V_{CE} = -7.182 \text{ V}$ $I_C = 15.93 \text{ mA}$	$V_{BE} = -846 \text{ mV}$ $V_{CE} = -7.182 \text{ V}$ $I_C = 16 \text{ mA}$

F05-45	$V_B = 774.4 \text{ mV}$ $V_C = 1.169 \text{ V}$ $V_E = 1.017 \text{ mA}$	$V_B = 774 \text{ mV}$ $V_C = 1.169 \text{ V}$ $V_E = 1.017 \text{ mA}$
TSE05-01	$V_B = 0.059 \mu\text{V}$ $V_C = 10.00 \text{ V}$ $V_E = 0.005 \mu\text{V}$	$V_B = 0.047 \mu\text{V}$ $V_C = 10.000 \text{ V}$ $V_E = 4.700 \text{ nV}$
TSE05-02	$V_B = 3.197 \text{ V}$ $V_C = 10.00 \text{ V}$ $V_E = 0.002 \mu\text{V}$	$V_B = 3.197 \text{ V}$ $V_C = 10.000 \text{ V}$ $V_E = 0.000 \text{ V}$
TSE05-03	$V_B = 3.145 \text{ V}$ $V_C = 5.061 \text{ V}$ $V_E = 2.329 \text{ V}$	$V_B = 3.145 \text{ V}$ $V_C = 5.061 \text{ V}$ $V_E = 2.329 \text{ V}$
TSE05-04	$V_B = 3.197 \text{ V}$ $V_C = 10.00 \text{ V}$ $V_E = 2.695 \text{ V}$	$V_B = 3.197 \text{ V}$ $V_C = 10.000 \text{ V}$ $V_E = 2.695 \text{ V}$
TSP05-51	$V_B = 668.8 \text{ mV}$ $V_C = 17.9 \text{ mV}$	$V_B = 669 \text{ mV}$ $V_C = 18 \text{ mV}$
TSP05-52	$I_B = 0.000 \mu\text{A}$	$I_B = -0.444 \text{ pA}$
TSP05-53	$V_B = 3.664 \text{ V}$	$V_B = 3.664 \text{ V}$
TSP05-54	$V_C = -2.846 \text{ V}$	$V_C = -2.846 \text{ V}$
TSP05-55	$V_C = -10.00 \text{ V}$ $V_E = 9.203 \text{ V}$	$V_C = -10.00 \text{ V}$ $V_E = 9.203 \text{ V}$
TSP05-56	$V_B = 2.999 \text{ V}$	$V_B = 2.999 \text{ V}$

Chapter 6:

Circuit	EWB	MultiSim
E06-08	$V_C = 5.529 \text{ V}$ $V_b = 25.8546 \text{ mV}_{PP}$ $V_c = 220.6865 \text{ mV}_{PP}$ DC values off, gain is OK	$V_C = 5.469 \text{ V}$ $V_b = 26.1 \text{ mV}_{PP}$ $V_c = 221.9 \text{ mV}_{PP}$ DC values off, gain is OK
E06-09	$V_b = 2.8045 \text{ mV}_{PP}$ $V_c = 2.7548 \text{ mV}_{PP}$ DC values off, gain is OK	$V_b = 2.8 \text{ mV}_{PP}$ $V_c = 2.8 \text{ mV}_{PP}$ DC values off, gain is OK
E06-11	$V_b = 13.8475 \text{ mV}_{PP}$ $V_c = 917.7385 \text{ mV}_{PP}$	$V_b = 14.0 \text{ mV}_{PP}$ $V_c = 930.5 \text{ mV}_{PP}$
F06-45	$V_B = 2.572 \text{ V}_{DC}$ $V_b = 99.99 \text{ mV}_{AC}$ $V_{OUT} = \sim 300 \mu\text{V}_{DC}$ $V_{out} = 214.5 \text{ mV}_{AC}$	$V_B = 2.570 \text{ V}_{DC}$ $V_b = 99 \text{ mV}_{AC}$ $V_{OUT} = \sim 0 \text{ V}_{DC}$ $V_{out} = 216 \text{ mV}_{AC}$
F06-46	$V_B = 2.439 \text{ V}_{DC}$ $V_b = 98.18 \text{ mV}_{AC}$ $V_{OUT} = 1.239 \text{ mV}_{DC}$ $V_{out} = 5.705 \text{ V}_{AC}$	Not implemented
F06-47	$V_B = 1.594 \text{ V}_{DC}$ $V_b = 100.0 \text{ mV}_{AC}$ $V_{OUT} = \sim 800 \mu\text{V}_{DC}$ $V_{out} = 395 \text{ mV}_{AC}$	$V_B = 1.593 \text{ V}_{DC}$ $V_b = 101 \text{ mV}_{AC}$ $V_{OUT} = \sim 0 \text{ mV}_{DC}$ $V_{out} = 347 \text{ mV}_{AC}$
F06-48	$V_B = 1.727 \text{ V}_{DC}$ $V_b = 1.000 \text{ V}_{AC}$ $V_{OUT} = \sim 80 \text{ mV}_{DC}$ $V_{out} = 885.1 \text{ mV}_{AC}$	$V_B = 1.741 \text{ V}_{DC}$ $V_b = 1.01 \text{ V}_{AC}$ $V_{OUT} = 88 \text{ mV}_{DC}$ $V_{out} = 881 \text{ mV}_{AC}$

F06-51	$V_B(1) = 2.491 \text{ V}$ $V_C(1) = 9.527 \text{ V}$ $V_E(1) = 1.737 \text{ V}$ $V_b(1) = 50.00 \text{ mV}$ $V_B(2) = 670.6 \text{ mV}$ $V_C(2) = 7.983 \text{ V}$ $V_{OUT}(2) = -128.5 \text{ mV}$ $V_{out}(2) = 6.195 \text{ V}$	Not implemented
F06-53	$V_{in} = 99.9 \text{ mV}$ $V_{out} = 3.13 \text{ V}$	$V_{in} = 0.100 \text{ mV}$ $V_{out} = 3.28 \text{ V}$
TSE06-01	$V_B(1) = 1.680 \text{ V}$ $V_C(1) = 5.768 \text{ V}$ $V_E(1) = 908.4 \text{ mV}$ $V_b(1) = 100.0 \mu\text{V}$ $V_c(1) = 5.094 \text{ mV}$ $V_e(1) = 0.483 \mu\text{V}$ $V_B(2) = 1.679 \text{ V}$ $V_C(2) = 5.678 \text{ V}$ $V_E(2) = 907.0 \text{ mV}$ $V_b(2) = 5.094 \text{ mV}$ $V_c(2) = 836.7 \text{ mV}$ $V_e(2) = 21.15 \mu\text{V}$ $V_{OUT} = \sim 85 \text{ mV}$ $V_{out} = 836.7 \text{ mV}$	$V_B(1) = 1.680 \text{ V}$ $V_C(1) = 5.772 \text{ V}$ $V_E(1) = 908 \text{ mV}$ $V_b(1) = 0.101 \text{ mV}$ $V_c(1) = 5.131 \text{ mV}$ $V_e(1) = 0.474 \mu\text{V}$ $V_B(2) = 1.680 \text{ V}$ $V_C(2) = 5.737 \text{ V}$ $V_E(2) = 0.909 \text{ V}$ $V_b(2) = 5.132 \text{ mV}$ $V_c(2) = 0.833 \text{ mV}$ $V_e(2) = 0.015 \text{ mV}$ $V_{OUT} = 0.033 \text{ V}$ $V_{out} = 832 \text{ mV}$
TSE06-02	$V_B(1) = 1.680 \text{ V}$ $V_C(1) = 5.770 \text{ V}$ $V_E(1) = 908.4 \text{ mV}$ $V_b(1) = 100.0 \mu\text{V}$ $V_c(1) = 16.35 \text{ mV}$ $V_e(1) = 0.420 \mu\text{V}$ $V_B(2) = 1.680 \text{ V}$ $V_C(2) = 5.679 \text{ V}$ $V_E(2) = 908.4 \text{ mV}$ $V_b(2) = 0.571 \mu\text{V}$ $V_c(2) = 32.46 \mu\text{V}$ $V_e(2) = 0.769 \mu\text{V}$ $V_{OUT} = \sim 3.338 \text{ mV}$ $V_{out} = 32.77 \mu\text{V}$	$V_B(1) = 1.680 \text{ V}$ $V_C(1) = 5.772 \text{ V}$ $V_E(1) = 0.908 \text{ mV}$ $V_b(1) = 0.101 \text{ mV}$ $V_c(1) = 0.016 \text{ V}$ $V_e(1) = 0.470 \mu\text{V}$ $V_B(2) = 1.680 \text{ V}$ $V_C(2) = 5.772 \text{ V}$ $V_E(2) = 0.908 \text{ V}$ $V_b(2) = 7.423 \text{ fV}$ $V_c(2) = 0.022 \text{ pV}$ $V_e(2) = 2.869 \text{ fV}$ $V_{OUT} = 1.841 \text{ pV}$ $V_{out} = 3.462 \text{ pV}$
TSE06-03	$V_B(1) = 1.680 \text{ V}$ $V_C(1) = 5.770 \text{ V}$ $V_E(1) = 908.4 \text{ mV}$ $V_b(1) = 100.0 \mu\text{V}$ $V_c(1) = 10.12 \text{ mV}$ $V_e(1) = 0.570 \mu\text{V}$ $V_B(2) = 1.680 \text{ V}$ $V_C(2) = 5.773 \text{ V}$ $V_E(2) = 908.1 \text{ mV}$ $V_b(2) = 10.12 \text{ mV}$ $V_c(2) = 45.80 \text{ mV}$ $V_e(2) = 9.844 \text{ mV}$ $V_{OUT} = 1.128 \text{ mV}$ $V_{out} = 45.80 \text{ mV}$	$V_B(1) = 1.680 \text{ V}$ $V_C(1) = 5.772 \text{ V}$ $V_E(1) = 908 \text{ mV}$ $V_b(1) = 0.101 \text{ mV}$ $V_c(1) = 0.010 \text{ V}$ $V_e(1) = 0.471 \mu\text{V}$ $V_B(2) = 1.680 \text{ V}$ $V_C(2) = 5.772 \text{ V}$ $V_E(2) = 0.908 \text{ V}$ $V_b(2) = 0.010 \text{ V}$ $V_c(2) = 0.046 \text{ mV}$ $V_e(2) = 9.867 \text{ mV}$ $V_{OUT} = -0.013 \text{ mV}$ $V_{out} = 0.046 \text{ V}$



TSE06-04	$V_B(1) = 1.680 \text{ V}$ $V_C(1) = 5.772 \text{ V}$ $V_E(1) = 908.5 \text{ mV}$ $V_b(1) = 100.0 \text{ } \mu\text{V}$ $V_c(1) = 10.41 \text{ mV}$ $V_e(1) = 0.109 \text{ } \mu\text{V}$ $V_B(2) = 1.754 \text{ V}$ $V_C(2) = 10.00 \text{ V}$ $V_E(2) = 0.002 \text{ } \mu\text{V}$ $V_b(2) = 10.41 \text{ mV}$ $V_c(2) = 0.000 \text{ } \mu\text{V}$ $V_e(2) = 0.000 \text{ } \mu\text{V}$ $V_{OUT} = -0.000 \text{ } \mu\text{V}$ $V_{out} = 0.000 \text{ } \mu\text{V}$	$V_B(1) = 1.680 \text{ V}$ $V_C(1) = 5.772 \text{ V}$ $V_E(1) = 908 \text{ mV}$ $V_b(1) = 0.101 \text{ mV}$ $V_c(1) = 0.010 \text{ V}$ $V_e(1) = 0.467 \text{ } \mu\text{V}$ $V_B(2) = 1.754 \text{ V}$ $V_C(2) = 9.999 \text{ V}$ $V_E(2) = 0.000 \text{ V}$ $V_b(2) = 0.010 \text{ V}$ $V_c(2) = 0.047 \text{ pV}$ $V_e(2) = 0.000 \text{ V}$ $V_{OUT} = 0.012 \text{ nV}$ $V_{out} = 0.016 \text{ nV}$
TSP06-54	$V_b = 99.90 \text{ mV}$ $V_c = 214.5 \text{ mV}$ $V_{out} = 5.361 \text{ } \mu\text{V}$	$V_b = 0.100 \text{ V}$ $V_c = 0.215 \text{ V}$ $V_{out} = 0.000 \text{ V}$
TSP06-55	$V_b = 99.02 \text{ mV}$ $I_E = 0.000 \text{ } \mu\text{A}$	$V_b = 0.100 \text{ V}$ $I_E = 1.8 \text{ fA}$
TSP06-56	$V_b = 100.0 \text{ mV}$ $V_{out} = 926.6 \text{ mV}$	$V_b = 0.099 \text{ V}$ $V_{out} = 0.928 \text{ V}$
TSP06-57	$V_{in} = 100.0 \text{ mV}$ $V_b = 0.000 \text{ } \mu\text{V}$ $V_{out} = 0.000 \text{ } \mu\text{V}$	$V_{in} = 0.100 \text{ V}$ $V_b = 0.011 \text{ pV}$ $V_{out} = 0.010 \text{ pV}$
TSP06-58	$V_b = 100.0 \text{ mV}$ $V_c = 119.9 \text{ mV}$	$V_b = 0.100 \text{ V}$ $V_c = 0.114 \text{ V}$
TSP06-59	$V_c(1) = 2.778 \text{ V}$ $V_b(2) = 0.129 \text{ } \mu\text{V}$	$V_c(1) = 2.764 \text{ V}$ $V_b(2) = 0.037 \text{ pV}$

Chapter 7:

Circuit	EWB	MultiSim
E07-06 Related Exercise	$I_D = 8.378 \text{ mA}$ $V_D = 5.053 \text{ V}$ $V_{GS} = -3.116$ $V_S = 3.147 \text{ V}$	$I_D = 8.078 \text{ mA}$ $V_D = 5.053 \text{ V}$ $V_{GS} = -3.116$ $V_S = 3.147 \text{ V}$
E07-09 Related Exercise	$I_D = 4.826 \text{ mA}$ $V_D = 7.762 \text{ V}$ $V_{GS} = -2.700$	$I_D = 4.827 \text{ mA}$ $V_D = 7.760 \text{ V}$ $V_{GS} = -2.700$
E07-12 Related Exercise	$I_D = 1.282 \text{ mA}$ $V_D = 7.129 \text{ V}$ $V_{GS} = -2.020 \text{ V}$	$I_D = 1.281 \text{ mA}$ $V_D = 7.129 \text{ V}$ $V_{GS} = -2.020 \text{ V}$
F07-58a	$V_{GS} = -996.7 \text{ mV}$ $V_{DS} = 6.262 \text{ V}$ $I_D = 1.007 \text{ mA}$	$V_{GS} = -0.997 \text{ V}$ $V_{DS} = 6.262 \text{ V}$ $I_D = 1.007 \text{ mA}$
F07-58b	$V_{GS} = -496.9 \text{ mV}$ $V_{DS} = 6.139 \text{ V}$ $I_D = 5.020 \text{ mA}$	$V_{GS} = -0.497 \text{ V}$ $V_{DS} = 6.139 \text{ V}$ $I_D = 5.020 \text{ mA}$
F07-58c	$V_{GS} = -1.408 \text{ V}$ $V_{DS} = 6.922 \text{ V}$ $I_D = 3.025 \text{ mA}$	$V_{GS} = -1.408 \text{ V}$ $V_{DS} = 6.922 \text{ V}$ $I_D = 3.025 \text{ mA}$
F07-61	$I_D = 2.854 \text{ mA}$ $V_{GS} = -856.0 \text{ mV}$	$I_D = 2.854 \text{ mA}$ $V_{GS} = -0.856 \text{ V}$
F07-62	$I_D = 3.356 \text{ mA}$ $V_{GS} = 1.190 \text{ V}$	$I_D = 3.356 \text{ mA}$ $V_{GS} = 1.190 \text{ V}$
F07-63	$I_D = 857.1 \text{ } \mu\text{A}$ $V_{GS} = -1.184 \text{ V}$	$I_D = 0.857 \text{ mA}$ $V_{GS} = -1.186 \text{ V}$

F07-64	$I_D = 1.917 \text{ mA}$ $V_{GS} = -1.508 \text{ V}$	$I_D = 1.917 \text{ mA}$ $V_{GS} = -1.508 \text{ V}$
F07-67a	$I_S = 8.000 \text{ mA}$ $V_{GS} = 4.000 \text{ V}$	$I_S = 8.000 \text{ mA}$ $V_{GS} = 4.000 \text{ V}$
F07-67b	$I_D = 8.000 \text{ mA}$ $V_{GS} = 5.400 \text{ V}$	$I_D = 8.000 \text{ mA}$ $V_{GS} = 5.400 \text{ V}$
F07-67c	$I_D = -8.000 \text{ mA}$ $V_{GS} = -4.520 \text{ V}$	$I_D = -8.000 \text{ mA}$ $V_{GS} = -4.520 \text{ V}$
F07-68	$I_D = 904.2 \mu\text{A}$ $V_{GS} = 3.098 \text{ V}$	$I_D = 0.904 \text{ mA}$ $V_{GS} = 3.098 \text{ V}$
F07-71	$V_{DS} = 10.94 \text{ V}$ $V_{GS} = -380.6 \text{ mV}$	$V_{DS} = 10.940 \text{ V}$ $V_{GS} = -0.381 \text{ V}$
TSE07-01	$V_{GS} = -80.14 \text{ mV}$ $V_D = 14.63 \text{ V}$ $V_S = 81.09 \text{ mV}$ $I_D = 367.7 \mu\text{A}$	$V_{GS} = -0.080 \text{ V}$ $V_D = 14.631 \text{ V}$ $V_S = 0.081 \text{ V}$ $I_D = 0.368 \text{ mA}$
TSE07-02	$V_{GS} = -0.001 \mu\text{V}$ $V_D = 0.010 \mu\text{V}$ $V_S = 0.001 \mu\text{V}$ $I_D = 0.000 \mu\text{A}$	$V_{GS} = 0.000 \text{ V}$ $V_D = 0.000 \text{ V}$ $V_S = 0.000 \text{ V}$ $I_D = 0.000 \text{ A}$
TSE07-03	$V_{GS} = -1.994 \text{ V}$ $V_D = 15.00 \text{ V}$ $V_S = 2.014 \text{ V}$ $I_D = 0.000 \mu\text{A}$	$V_{GS} = -1.994 \text{ V}$ $V_D = 14.999 \text{ V}$ $V_S = 2.014 \text{ V}$ $I_D = -1.776 \mu\text{A}$
TSP07-66	$V_D = 30.93 \text{ mV}$ $V_S = 0.003 \mu\text{V}$ $V_G = 0.345 \mu\text{V}$	$V_D = 0.031 \text{ V}$ $V_S = 2.547 \text{ pV}$ $V_G = 0.345 \mu\text{V}$
TSP07-67	$V_D = 6.000 \text{ V}$ $V_S = 906.3 \text{ mV}$ $V_G = 62.97 \mu\text{V}$	$V_D = 6.000 \text{ V}$ $V_S = 0.906 \text{ V}$ $V_G = 0.063 \text{ mV}$
TSP07-68	$V_D = -2.988 \text{ V}$ $V_S = -1.303 \text{ V}$ $V_G = -0.000 \mu\text{V}$	$V_D = -2.988 \text{ V}$ $V_S = -1.303 \text{ V}$ $V_G = -0.004 \text{ aV}$
TSP07-69	$V_D = 7.166 \text{ V}$ $V_S = 1.287 \text{ V}$ $V_G = 23.08 \mu\text{V}$	$V_D = 7.166 \text{ V}$ $V_S = 1.287 \text{ V}$ $V_G = 0.018 \text{ mV}$
TSP07-70	$V_D = 12.00 \text{ V}$ $V_S = 0.015 \mu\text{V}$ $V_G = 4.737 \text{ V}$	$V_D = 12.000 \text{ V}$ $V_S = 0.000 \text{ V}$ $V_G = 4.737 \text{ V}$
TSP07-71	$V_D = 0.001 \mu\text{V}$ $V_G = -0.000 \mu\text{V}$	$V_D = 0.000 \text{ V}$ $V_G = 0.000 \text{ V}$
TSP07-72	$V_D = 10.00 \text{ V}$ $V_G = 0.000 \mu\text{V}$	$V_D = 10.000 \text{ V}$ $V_G = 1.000 \text{ fV}$
TSP07-73	$V_D = 4.307 \text{ V}$ $V_S = 4.307 \text{ V}$ $V_G = 0.000 \mu\text{V}$	$V_D = 4.307 \text{ V}$ $V_S = 4.307 \text{ V}$ $V_G = 0.000 \text{ V}$
TSP07-74	$V_D = 8.352 \text{ V}$ $V_S = 8.311 \text{ V}$ $V_G = 9.000 \text{ V}$	$V_D = 8.352 \text{ V}$ $V_S = 8.311 \text{ V}$ $V_G = 9.000 \text{ V}$

Chapter 8:

Circuit	EWB	MultiSim
E08-04	$V_D = 5.510 \text{ V}_{DC}$ $V_d = 1.066 \text{ V}_{rms}$	$V_D = 5.490 \text{ V}_{DC}$ $V_d = 1.067 \text{ V}_{rms}$
E08-07	$V_D = 8.397 \text{ V}_{DC}$ $V_d = 328.6 \text{ mV}_{rms}$ $V_g = 49.99 \text{ mV}_{rms}$	$V_D = 8.397 \text{ V}_{DC}$ $V_d = 0.329 \text{ V}_{rms}$ $V_g = 0.050 \text{ V}_{rms}$

E08-09	$I_S = 2.636 \text{ mA}_{DC}$ $V_D = 6.307 \text{ V}_{DC}$ $V_I = 1.713 \text{ V}_{rms}$	$I_S = 2.638 \text{ mA}_{DC}$ $V_D = 6.305 \text{ V}_{DC}$ $V_I = 1.711 \text{ V}_{rms}$
E08-10	$V_{GS} = -568.4 \text{ mV}_{DC}$ $V_{in} = 10.00 \text{ mV}_{rms}$ $V_{out} = 8.725 \text{ mV}_{rms}$	$V_{GS} = -0.568 \text{ V}_{DC}$ $V_{in} = 0.010 \text{ V}_{rms}$ $V_{out} = 8.732 \text{ mV}_{rms}$
E08-11	$V_{in} = 10.00 \text{ mV}_{rms}$ $V_{out} = 101.1 \text{ mV}_{rms}$	$V_{in} = 0.010 \text{ V}_{rms}$ $V_{out} = 0.101 \text{ V}_{rms}$
F08-35	$I_D = 2.833 \text{ mA}_{DC}$ $V_{DS} = 4.916 \text{ V}_{DC}$ $V_S = 2.833 \text{ V}_{DC}$	$I_D = 2.834 \text{ mA}_{DC}$ $V_{DS} = 4.914 \text{ V}_{DC}$ $V_S = 2.834 \text{ V}_{DC}$
F08-36a	$I_D = 1.844 \text{ mA}_{DC}$ $V_{in} = 50.00 \text{ mV}_{rms}$ $V_{out} = 215.4 \text{ mV}_{rms}$	$I_D = 1.843 \text{ mA}_{DC}$ $V_{in} = 0.050 \text{ V}_{rms}$ $V_{out} = 0.216 \text{ V}_{rms}$
F08-36b	$I_D = 1.016 \text{ mA}_{DC}$ $V_{in} = 50.00 \text{ mV}_{rms}$ $V_{out} = 496.5 \text{ mV}_{rms}$	$I_D = 1.016 \text{ mA}_{DC}$ $V_{in} = 0.050 \text{ V}_{rms}$ $V_{out} = 0.497 \text{ V}_{rms}$
F08-37	$I_D = 5.847 \text{ mA}_{DC}$ $V_{in} = 50.00 \text{ mV}_{rms}$ $V_{out} = 141.5 \text{ mV}_{rms}$	$I_D = 5.847 \text{ mA}_{DC}$ $V_{in} = 0.050 \text{ V}_{rms}$ $V_{out} = 0.142 \text{ V}_{rms}$
F08-38	$I_D = 4.463 \text{ mA}_{DC}$ $V_{DS} = 3.065 \text{ V}_{DC}$ $V_G = -1.458 \text{ V}_{DC}$	$I_D = 4.463 \text{ mA}_{DC}$ $V_{DS} = 3.065 \text{ V}_{DC}$ $V_G = -1.458 \text{ V}_{DC}$
F08-39	$V_D = 17.15 \text{ V}_{DC}$ $V_G = 5.484 \text{ V}_{DC}$ $I_S = 2.849 \text{ mA}_{DC}$	$V_D = 17.151 \text{ V}_{DC}$ $V_G = 5.484 \text{ V}_{DC}$ $I_S = 2.849 \text{ mA}_{DC}$
F08-41	$V_D = 15.00 \text{ mA}_{DC}$ $V_D = 9.000 \text{ V}_{DC}$ $V_d = 48.00 \text{ mV}_{rms}$ $V_{in} = 10.00 \text{ mV}_{rms}$	$V_D = 0.015 \text{ A}_{DC}$ $V_D = 9.000 \text{ V}_{DC}$ $V_d = 0.048 \text{ V}_{rms}$ $V_{in} = 0.010 \text{ V}_{rms}$
F08-44a	$I_D = 279.4 \mu\text{A}_{DC}$ $V_{in} = 50.00 \text{ mV}_{rms}$ $V_{out} = 45.26 \text{ mV}_{rms}$	$I_D = 0.280 \text{ mA}_{DC}$ $V_{in} = 0.050 \text{ V}_{rms}$ $V_{out} = 0.045 \text{ V}_{rms}$
F08-44b	$I_D = 6.615 \text{ mA}_{DC}$ $V_{in} = 50.00 \text{ mV}_{rms}$ $V_{out} = 14.01 \text{ mV}_{rms}$	$I_D = 6.615 \text{ mA}_{DC}$ $V_{in} = 0.050 \text{ V}_{rms}$ $V_{out} = 0.014 \text{ V}_{rms}$
TSE08-01	$V_{in} = 10.00 \text{ mV}_{rms}$ $I_D(1) = 3.126 \text{ mA}_{DC}$ $V_D(1) = 7.313 \text{ V}_{DC}$ $V_G(2) = -227.9 \mu\text{V}_{DC}$ $V_g(2) = 75.00 \text{ mV}_{rms}$ $I_D(2) = 3.132 \text{ mA}_{DC}$ $V_{out}(2) = 562.3 \text{ mV}_{rms}$	$V_{in} = 0.010 \text{ V}_{rms}$ $I_D(1) = 3.125 \text{ mA}_{DC}$ $V_D(1) = 7.312 \text{ V}_{DC}$ $V_G(2) = -0.416 \text{ mV}_{DC}$ $V_g(2) = 0.075 \text{ V}_{rms}$ $I_D(2) = 3.134 \text{ mA}_{DC}$ $V_{out}(2) = 0.563 \text{ V}_{rms}$
TSE08-02	$V_{in} = 10.00 \text{ mV}_{rms}$ $I_D(1) = 6.092 \text{ mA}_{DC}$ $V_D(1) = 2.863 \text{ V}_{DC}$ $V_G(2) = 2.863 \text{ V}_{DC}$ $V_g(2) = 433.5 \mu\text{V}_{rms}$ $I_D(2) = 6.115 \text{ mA}_{DC}$ $V_{out}(2) = 128.6 \mu\text{V}_{rms}$	$V_{in} = 0.010 \text{ V}_{rms}$ $I_D(1) = 6.092 \text{ mA}_{DC}$ $V_D(1) = 2.863 \text{ V}_{DC}$ $V_G(2) = 2.863 \text{ V}_{DC}$ $V_g(2) = 0.434 \text{ mV}_{rms}$ $I_D(2) = 6.115 \text{ mA}_{DC}$ $V_{out}(2) = 0.128 \text{ mV}_{rms}$
TSE08-03	$V_{in} = 10.00 \text{ mV}_{rms}$ $I_D(1) = 0.000 \mu\text{A}_{DC}$ $V_D(1) = 12.00 \text{ V}_{DC}$ $V_G(2) = 67.36 \mu\text{V}_{DC}$ $V_g(2) = 0.000 \mu\text{V}_{rms}$ $I_D(2) = 3.125 \text{ mA}_{DC}$ $V_{out}(2) = 0.000 \mu\text{V}_{rms}$	$V_{in} = 0.010 \text{ V}_{rms}$ $I_D(1) = 1.776 \mu\text{A}_{DC}$ $V_D(1) = 12.001 \text{ V}_{DC}$ $V_G(2) = 0.067 \text{ mV}_{DC}$ $V_g(2) = 0.020 \text{ nV}_{rms}$ $I_D(2) = 3.125 \text{ mA}_{DC}$ $V_{out}(2) = 0.441 \mu\text{V}_{rms}$

TSE08-04	$V_{in} = 10.00 \text{ mV}_{rms}$ $I_D(1) = 3.125 \text{ mA}_{DC}$ $V_D(1) = 7.313 \text{ V}_{DC}$ $V_G(2) = <500 \text{ } \mu\text{V}_{DC}$ $V_g(2) = 75.00 \text{ mV}_{rms}$ $I_D(2) = 0.000 \text{ } \mu\text{A}_{DC}$ $V_{out}(2) = 0.000 \text{ } \mu\text{V}_{rms}$	$V_{in} = 0.010 \text{ V}_{rms}$ $I_D(1) = 3.126 \text{ mA}_{DC}$ $V_D(1) = 7.312 \text{ V}_{DC}$ $V_G(2) = <500 \text{ } \mu\text{V}_{DC}$ $V_g(2) = 0.075 \text{ V}_{rms}$ $I_D(2) = -2.35 \text{ aA}_{DC}$ $V_{out}(2) = 0.026 \text{ nV}_{rms}$
TSP08-46	$I_D = 4.800 \text{ mA}_{DC}$ $V_{DS} = 0.005 \text{ } \mu\text{V}_{DC}$ $V_S = 4.800 \text{ V}_{DC}$	$I_D = 4.800 \text{ mA}_{DC}$ $V_{DS} = 4.801 \text{ pV}_{DC}$ $V_S = 4.800 \text{ V}_{DC}$
TSP08-47	$I_D = 1.842 \text{ mA}_{DC}$ $V_S = 34.02 \text{ mV}_{rms}$ $V_{in} = 50.00 \text{ mV}_{rms}$ $V_{out} = 69.14 \text{ mV}_{rms}$	$I_D = 1.842 \text{ mA}_{DC}$ $V_S = 0.034 \text{ V}_{rms}$ $V_{in} = 0.050 \text{ V}_{rms}$ $V_{out} = 0.069 \text{ V}_{rms}$
TSP08-48	$I_D = 1.000 \text{ mA}_{DC}$ $V_G = 0.008 \text{ } \mu\text{V}_{rms}$ $V_{in} = 50.00 \text{ mV}_{rms}$ $V_{out} = 0.084 \text{ } \mu\text{V}_{rms}$	$I_D = 1.000 \text{ mA}_{DC}$ $V_G = 0.000 \text{ V}_{rms}$ $V_{in} = 0.050 \text{ V}_{rms}$ $V_{out} = 0.021 \text{ nV}_{rms}$
TSP08-49	$I_D = 12.70 \text{ mA}_{DC}$ $V_{GS} < 200 \text{ } \mu\text{V}_{DC}$ $V_{in} = 50.00 \text{ mV}_{rms}$ $V_{out} = 208.5 \text{ mV}_{rms}$	$I_D = 0.013 \text{ A}_{DC}$ $V_{GS} < 0.3 \text{ mV}_{DC}$ $V_{in} = 0.050 \text{ V}_{rms}$ $V_{out} = 0.209 \text{ V}_{rms}$
TSP08-50	$I_D = 0.009 \text{ } \mu\text{A}_{DC}$ $V_{DS} = 9.000 \text{ V}_{DC}$ $V_{GS} = 26.89 \text{ } \mu\text{V}_{DC}$	$I_D = 9.008 \text{ nA}_{DC}$ $V_{DS} = 9.000 \text{ V}_{DC}$ $V_{GS} = -2.941 \text{ } \mu\text{V}_{DC}$
TSP08-51	$V_{R1} = 20.00 \text{ V}_{DC}$ $V_G = 136.0 \text{ } \mu\text{V}_{DC}$ $V_D = 20.00 \text{ V}_{DC}$ $I_D = 0.000 \text{ } \mu\text{A}_{DC}$	$V_{R1} = 20.00 \text{ V}_{DC}$ $V_G = 0.136 \text{ mV}_{DC}$ $V_D = 20.00 \text{ V}_{DC}$ $I_D = 0.028 \text{ nA}_{DC}$
TSP08-52	$V_{RD} = 24.00 \text{ V}_{DC}$ $V_{in} = 10.00 \text{ mV}_{rms}$ $I_D = 0.240 \text{ } \mu\text{A}_{DC}$ $V_D = 50.00 \text{ } \mu\text{V}_{DC}$ $V_d = 2.291 \text{ } \mu\text{V}_{rms}$ $V_{out} = 2.291 \text{ } \mu\text{V}_{rms}$	$V_{RD} = 24.00 \text{ V}_{DC}$ $V_{in} = 0.010 \text{ V}_{rms}$ $I_D = 0.240 \text{ } \mu\text{A}_{DC}$ $V_D = 0.050 \text{ mV}_{DC}$ $V_d = 0.080 \text{ } \mu\text{V}_{rms}$ $V_{out} = 0.080 \text{ } \mu\text{V}_{rms}$
TSP08-53	$I_D = 9.876 \text{ mA}_{DC}$ $V_{DS} = 3.186 \text{ V}_{DC}$ $V_{GS} = 17.99 \text{ V}_{DC}$ $V_{out} = 23.65 \text{ mV}_{rms}$	$I_D = 9.876 \text{ mA}_{DC}$ $V_{DS} = 3.186 \text{ V}_{DC}$ $V_{GS} = 17.992 \text{ V}_{DC}$ $V_{out} = 0.024 \text{ V}_{rms}$
TSP08-54	$I_D = 279.5 \text{ } \mu\text{A}_{DC}$ $V_B = 46.67 \text{ mV}_{rms}$ $V_{in} = 10.00 \text{ mV}_{rms}$ $V_{out} = 0.000 \text{ } \mu\text{V}_{rms}$	$I_D = 0.280 \text{ mA}_{DC}$ $V_B = 0.047 \text{ V}_{rms}$ $V_{in} = 0.010 \text{ V}_{rms}$ $V_{out} = 0.000 \text{ V}_{rms}$

Chapter 9:

Circuit	EWB	MultiSim
E09-03 Lower than 40 $V_{PP}$	$V_{out} = 35.5 \text{ V}_{PP}$	$V_{out} = 35.5 \text{ V}_{PP}$ (clipped)
E09-04 Lower than 20 $V_{PP}$	$V_{out} = 13.35 \text{ V}_{PP}$	$V_{out} = 13.6 \text{ V}_{PP}$
F09-41	$V_{CE} = 6.270 \text{ V}$ $I_C = 60.36 \text{ mA}$	$V_{CE} = 6.263 \text{ V}$ $I_C = 0.060 \text{ mA}$
F09-43	$V_{out} = 6.522 \text{ V}_{PP}$ for $V_{in} = 100 \text{ mV}_{rms}$	$V_{out} = 6.3 \text{ V}_{PP}$ for $V_{in} = 100 \text{ mV}_{rms}$
F09-44	$V_{out} = 13.5329 \text{ V}_{PP}$	$V_{out} = 13.6 \text{ V}_{PP}$
F09-45	$V_{out} = 13.6346 \text{ V}_{PP}$	$V_{out} = 13.8 \text{ V}_{PP}$

F09-46	$V_{out} = 21.4134 V_{PP}$ $I_{out} = 224.4 \text{ mArms}$	$V_{out} = 21.3 V_{PP}$ $I_{out} = 225 \text{ mA}$
TSE09-01	$V_B = 3.360 V_{DC}$ with output clipped on bottom	$V_B = 3.360 V_{DC}$ with output clipped on bottom
TSE09-02	$V_B = 839.2 \text{ mV}_{DC}$ $V_{out(max)} = 2.2982 V_P$ $V_{out(min)} = -1.9019 V_P$	$V_B = 0.839 V_{DC}$ $V_{out(max)} = 2.2 V_P$ $V_{out(min)} = -1.8 V_P$
TSE09-03	$V_B = 1.8256 V_{DC}$ with nonlinear distortion	$V_B = 1.826 V_{DC}$ with nonlinear distortion
TSP09-35	$I_C = 60.30 \text{ mA}_{DC}$ $V_{CE} = 6.278 V_{DC}$ $V_D = 0.061 \mu V_{rms}$	$I_C = 0.060 A_{DC}$ $V_{CE} = 6.278 V_{DC}$ $V_D = 0.019 \text{ pV}_{rms}$
TSP09-36	$V_B = 4.214 V_{DC}$ $V_{RE2} = 3.702 V_{DC}$ $V_{out}$ is negative pulses	$V_B = 4.208 V_{DC}$ $V_{RE2} = 3.767 V_{DC}$ $V_{out}$ is negative pulses
TSP09-37	$V_{out} = -6.75 V_P$ half-wave output	$V_{out} = -6.8 V_P$ half-wave output
TSP09-38	$V_{D2} = 0.007 \mu V_{DC}$ $V_{out} = 12.87 V_{PP}$	$V_{D2} = 6.886 \text{ pV}_{DC}$ $V_{out} = 13.0 V_{PP}$
TSP09-39	$V_{out}$ is positive half-wave output	$V_{out}$ is positive half-wave output

Chapter 10:

Circuit	EWB	MultiSim
E10-06 Ideal = 78.5 Hz	$f_C = 79.6 \text{ Hz}$	$f_C = 66.1 \text{ Hz}$
E10-07	$f_C = 16.2 \text{ Hz}$	$f_C = 16 \text{ Hz}$
E10-08	$f_C = 17.1 \text{ Hz}$	$f_C = 17 \text{ Hz}$
E10-10 Ideal = 1.62 MHz	$f_C = 1.77 \text{ MHz}$	$f_C = 1.8 \text{ MHz}$
F10-50	$f_C(1) = 3.1 \text{ kHz}$ $f_C(2) = 24.9 \text{ MHz}$	$f_C(1) = 3.1 \text{ kHz}$ $f_C(2) = 26 \text{ kHz}$
F10-51	$f_C = 9.23 \text{ kHz}$	$f_C = 95 \text{ kHz}$
F10-54	$f_C = 3.16 \text{ kHz}$	$f_C = 2.95 \text{ kHz}$
TSP10-45	$V_{RC} = 19.77 V_{DC}$	$V_{RC} = 19.765 V_{DC}$
TSP10-46	$V_d = 205 \text{ mV}_{PP}$ $V_{out} = 0 V_{rms}$	$V_d = 204.1 \text{ mV}_{PP}$ $V_{out} = 0.0 V_{rms}$
TSP10-47	$V_B = 2.591 V_{DC}$	$V_B = 2.610 V_{DC}$
TSP10-48	$V_{RD} = 10 V_{DC}$ $I_D = 17.86 \text{ mA}$	$V_{RD} = 10.00 V_{DC}$ $I_D = 0.018 \text{ A}$

Chapter 11:

Circuit	EWB	MultiSim
E11-02	$I = 109.1 \text{ mA}$	Not implemented
E11-03	$I_{SCR} = 23.18 \text{ mA}$ Expected SCR operation	$I_{SCR} = 0.023 \text{ A}$ Expected SCR operation
E11-04	Sine wave with missing piece from $90^\circ$ to $180^\circ$	Not implemented
F11-61	$I = 0.250 \mu A$	Not implemented
F11-62	Expected SCR operation	Expected SCR operation
F11-64	Expected diac operation	Not implemented
TSP11-31	Diode always on	Not implemented
TSP11-32	SCR never fires	SCR never fires
TSP11-33	$V_{R1} = 0.249 \mu V_{rms}$ $V_{out}$ is half-wave output	$VR1 = 0.100 \text{ nV}$ $V_{out}$ is half-wave output

## Chapter 12:

Circuit	EWB	MultiSim
E12-03	$V_{in} = 100.0 \text{ mV}_{\text{rms}}$ $V_{out} = 2.228 \text{ V}_{\text{rms}}$	$V_{in} = 0.100 \text{ V}_{\text{rms}}$ $V_{out} = 2.228 \text{ V}_{\text{rms}}$
E12-04	$V_{in} = 100.0 \text{ mV}_{\text{rms}}$ $V_{out} = 10.00 \text{ V}_{\text{rms}}$	$V_{in} = 0.100 \text{ V}_{\text{rms}}$ $V_{out} = 10.002 \text{ V}_{\text{rms}}$
E12-05	$V_{in} = 100.0 \text{ mV}_{\text{rms}}$ $V_{out} = 2.300 \text{ V}_{\text{rms}}$	$V_{in} = 0.100 \text{ V}_{\text{rms}}$ $V_{out} = 2.302 \text{ V}_{\text{rms}}$
E12-07	$V_{in} = 10.0 \text{ mV}_{\text{rms}}$ $V_{out} = 10.00 \text{ V}_{\text{rms}}$	$V_{in} = 0.010 \text{ V}_{\text{rms}}$ $V_{out} = 10.004 \text{ V}_{\text{rms}}$
E12-12	BW(1) = 41.6 kHz BW(2) = 62.7 kHz	Not implemented
F12-53	$V_{in} = 10.0 \text{ mV}_{\text{rms}}$ $V_{out} = 3.741 \text{ V}_{\text{rms}}$	$V_{in} = 0.010 \text{ V}_{\text{rms}}$ $V_{out} = 3.741 \text{ V}_{\text{rms}}$
F12-54a	$V_{in} = 10.0 \text{ mV}_{\text{rms}}$ $V_{out} = 110.0 \text{ mV}_{\text{rms}}$	$V_{in} = 0.010 \text{ V}_{\text{rms}}$ $V_{out} = 0.110 \text{ V}_{\text{rms}}$
F12-54b	$V_{in} = 10.0 \text{ mV}_{\text{rms}}$ $V_{out} = 1.009 \text{ V}_{\text{rms}}$	$V_{in} = 0.010 \text{ V}_{\text{rms}}$ $V_{out} = 1.010 \text{ V}_{\text{rms}}$
F12-54c	$V_{in} = 10.0 \text{ mV}_{\text{rms}}$ $V_{out} = 478.0 \text{ mV}_{\text{rms}}$	$V_{in} = 0.010 \text{ V}_{\text{rms}}$ $V_{out} = 0.478 \text{ V}_{\text{rms}}$
F12-54d	$V_{in} = 10.0 \text{ mV}_{\text{rms}}$ $V_{out} = 230.0 \text{ mV}_{\text{rms}}$	$V_{in} = 0.010 \text{ V}_{\text{rms}}$ $V_{out} = 0.230 \text{ V}_{\text{rms}}$
F12-56a	$V_{in} = 1.000 \text{ V}_{\text{rms}}$ $V_{out} = 1.000 \text{ V}_{\text{rms}}$	$V_{in} = 1.000 \text{ V}_{\text{rms}}$ $V_{out} = 1.000 \text{ V}_{\text{rms}}$
F12-56b	$V_{in} = 1.000 \text{ V}_{\text{rms}}$ $V_{out} = 1.000 \text{ V}_{\text{rms}}$	$V_{in} = 1.000 \text{ V}_{\text{rms}}$ $V_{out} = 1.000 \text{ V}_{\text{rms}}$
F12-56c	$V_{in} = 10.00 \text{ mV}_{\text{rms}}$ $V_{out} = 222.8 \text{ mV}_{\text{rms}}$	$V_{in} = 0.010 \text{ V}_{\text{rms}}$ $V_{out} = 0.223 \text{ V}_{\text{rms}}$
F12-56d	$V_{in} = 1.000 \text{ V}_{\text{rms}}$ $V_{out} = 10.00 \text{ V}_{\text{rms}}$	$V_{in} = 1.000 \text{ V}_{\text{rms}}$ $V_{out} = 9.998 \text{ V}_{\text{rms}}$
F12-57	$V_{in} = 1.000 \text{ V}_{\text{rms}}$ $I_S = 30.31 \mu\text{A}_{\text{rms}}$ $V_{out} = 10.00 \text{ V}_{\text{rms}}$ $I_f = 30.31 \mu\text{A}_{\text{rms}}$	$V_{in} = 1.000 \text{ V}_{\text{rms}}$ $I_S = 0.030 \text{ mA}_{\text{rms}}$ $V_{out} = 10.00 \text{ V}_{\text{rms}}$ $I_f = 0.030 \text{ mA}_{\text{rms}}$
F12-58a	$V_{in} = 10.00 \text{ mV}_{\text{rms}}$ $I_S = 0.000 \mu\text{A}_{\text{rms}}$ $V_{out} = 2.2468 \text{ V}_{\text{rms}}$ $I_f = 4.017 \mu\text{A}_{\text{rms}}$	$V_{in} = 0.010 \text{ V}_{\text{rms}}$ $I_S = 0.100 \text{ nA}_{\text{rms}}$ $V_{out} = 2.252 \text{ V}_{\text{rms}}$ $I_f = 4.027 \mu\text{A}_{\text{rms}}$
F12-58b	$V_{in} = 10.00 \text{ mV}_{\text{rms}}$ $I_S = 0.000 \mu\text{A}_{\text{rms}}$ $V_{out} = 323.2 \text{ mV}_{\text{rms}}$ $I_f = 6.670 \mu\text{A}_{\text{rms}}$	$V_{in} = 0.010 \text{ V}_{\text{rms}}$ $I_S = 0.100 \text{ nA}_{\text{rms}}$ $V_{out} = 0.324 \text{ mV}_{\text{rms}}$ $I_f = 6.685 \mu\text{A}_{\text{rms}}$
F12-58c	$V_{in} = 10.00 \text{ mV}_{\text{rms}}$ $I_S = 0.000 \mu\text{A}_{\text{rms}}$ $V_{out} = 188.5 \text{ mV}_{\text{rms}}$ $I_f = 0.180 \mu\text{A}_{\text{rms}}$	$V_{in} = 0.010 \text{ V}_{\text{rms}}$ $I_S = 0.100 \text{ nA}_{\text{rms}}$ $V_{out} = 0.189 \text{ mV}_{\text{rms}}$ $I_f = 0.181 \mu\text{A}_{\text{rms}}$
F12-60a	$V_{in} = 10.00 \text{ mV}_{\text{rms}}$ $I_S = 1.000 \mu\text{A}_{\text{rms}}$ $V_{out} = 150.0 \text{ mV}_{\text{rms}}$ $I_f = 1.001 \mu\text{A}_{\text{rms}}$	$V_{in} = 0.010 \text{ V}_{\text{rms}}$ $I_S = 1.004 \mu\text{A}_{\text{rms}}$ $V_{out} = 0.151 \text{ V}_{\text{rms}}$ $I_f = 1.005 \mu\text{A}_{\text{rms}}$
F12-60b	$V_{in} = 10.00 \text{ mV}_{\text{rms}}$ $I_S = 0.100 \mu\text{A}_{\text{rms}}$ $V_{out} = 998.7 \text{ V}_{\text{rms}}$ $I_f = 0.110 \mu\text{A}_{\text{rms}}$	$V_{in} = 0.010 \text{ V}_{\text{rms}}$ $I_S = 0.101 \mu\text{A}_{\text{rms}}$ $V_{out} = 1.004 \text{ V}_{\text{rms}}$ $I_f = 0.110 \mu\text{A}_{\text{rms}}$

F12-60c	$V_{in} = 10.00 \text{ mV}_{\text{rms}}$ $I_S = 21.27 \text{ }\mu\text{A}_{\text{rms}}$ $V_{out} = 212.8 \text{ mV}_{\text{rms}}$ $I_f = 21.27 \text{ }\mu\text{A}_{\text{rms}}$	$V_{in} = 0.010 \text{ mV}_{\text{rms}}$ $I_S = 0.021 \text{ mA}_{\text{rms}}$ $V_{out} = 0.213 \text{ V}_{\text{rms}}$ $I_f = 0.021 \text{ mA}_{\text{rms}}$
TSE12-01	$V_{in} = 100.0 \text{ mV}_{\text{rms}}$ $V_{out} = 2.228 \text{ mV}_{\text{rms}}$	$V_{in} = 0.100 \text{ V}_{\text{rms}}$ $V_{out} = 2.230 \text{ V}_{\text{rms}}$
TSE12-02	$V_{in} = 0.069 \text{ }\mu\text{V}_{\text{rms}}$ $V_{out}$ is railed	$V_{in} = 0.047 \text{ }\mu\text{V}_{\text{rms}}$ $V_{out}$ is railed
TSE12-03	$V_{in} = 100.0 \text{ mV}_{\text{rms}}$ $V_{out} = 10.00 \text{ V}_{\text{rms}}$	$V_{in} = 0.100 \text{ V}_{\text{rms}}$ $V_{out} = 10.004 \text{ V}_{\text{rms}}$
TSE12-04	$V_{in} = 100.0 \text{ mV}_{\text{rms}}$ $V_{out} = 0.006 \text{ }\mu\text{V}_{\text{rms}}$	$V_{in} = 0.100 \text{ V}_{\text{rms}}$ $V_{out} = 0.000 \text{ V}_{\text{rms}}$
TSP12-57	$V_{in} = 10.00 \text{ mV}_{\text{rms}}$ $V_{out}$ is railed	$V_{in} = 0.010 \text{ V}_{\text{rms}}$ $V_{out}$ is railed
TSP12-58	$V_{in} = 1.0 \text{ V}_{\text{rms}}$ $V_{out} = 1.0 \text{ V}_{\text{rms}}$	$V_{in} = 1.0 \text{ V}_{\text{rms}}$ $V_{out} = 1.0 \text{ V}_{\text{rms}}$
TSP12-59	$V_{in} = 10 \text{ mV}_{\text{rms}}$ $V_{out} = 10 \text{ mV}_{\text{rms}}$	$V_{in} = 0.010 \text{ V}_{\text{rms}}$ $V_{out} = 0.010 \text{ V}_{\text{rms}}$
TSP12-60	$V_{out}$ is railed $V_{Ri} = 0.000 \text{ V}_{\text{rms}}$	$V_{out}$ is railed $V_{Ri} = 64.3 \text{ pV}_{\text{rms}}$
TSP12-61	$V_{in} = 10.00 \text{ mV}_{\text{rms}}$ $V_{out} \approx 10.00 \text{ mV}_{\text{rms}}$	$V_{in} = 0.010 \text{ V}_{\text{rms}}$ $V_{out} \approx 0.010 \text{ V}_{\text{rms}}$
TSP12-62	$V_{in} = 1.0 \text{ V}_{\text{rms}}$ $V_{out} \approx 0.5 \text{ V}_{\text{rms}}$	$V_{in} = 1.0 \text{ V}_{\text{rms}}$ $V_{out} \approx 0.5 \text{ V}_{\text{rms}}$
TSP12-63	$V_{in} = 5.0 \text{ V}_{\text{rms}}$ $V_{out} \approx 5 \text{ mV}_{\text{rms}}$	$V_{in} = 5.0 \text{ V}_{\text{rms}}$ $V_{out} \approx 5.0 \text{ mV}_{\text{rms}}$
TSP12-64	$V_{in} = 1.0 \text{ mV}_{\text{rms}}$ $V_{out} \approx 10 \text{ V}_{\text{rms}}$	$V_{in} = 1 \text{ mV}_{\text{rms}}$ $V_{out} \approx 10 \text{ V}_{\text{rms}}$
TSP12-65	$V_{in} = 1.0 \text{ V}_{\text{rms}}$ $V_{out}$ is railed	$V_{in} = 1 \text{ V}_{\text{rms}}$ $V_{out}$ is railed
TSP12-66	$V_{in} = 1.0 \text{ V}_{\text{rms}}$ $V_{out} = 0 \text{ V}$	$V_{in} = 1.0 \text{ V}_{\text{rms}}$ $V_{out} = 0 \text{ V}$
TSP12-67	$V_{in} = 1.0 \text{ V}_{\text{rms}}$ $V_{out}$ is railed	$V_{in} = 1.0 \text{ V}_{\text{rms}}$ $V_{out}$ is railed
TSP12-68	$V_{in} = 1.0 \text{ V}_{\text{rms}}$ $V_{out} \approx 1.0 \text{ V}_{\text{rms}}$	$V_{in} = 1.0 \text{ V}_{\text{rms}}$ $V_{out} \approx 1.01 \text{ V}_{\text{rms}}$
TSP12-69	$V_{in} = 10 \text{ mV}_{\text{rms}}$ $V_{out}$ is railed	$V_{in} = 10 \text{ mV}_{\text{rms}}$ $V_{out}$ is railed
TSP12-70	$V_{in} = 1.0 \text{ V}_{\text{rms}}$ $V_{out} = 0 \text{ V}$	$V_{in} = 1.0 \text{ V}_{\text{rms}}$ $V_{out} = 1.0 \text{ pV}_{\text{rms}}$
TSP12-71	$V_{in} = 1.0 \text{ V}_{\text{rms}}$ $V_{out} = 0 \text{ V}$	$V_{in} = 1.0 \text{ V}_{\text{rms}}$ $V_{out} = 0 \text{ V}$
TSP12-72	$V_{in} = 10 \text{ mV}_{\text{rms}}$ $V_{out} \approx 1.2 \text{ V}_{\text{rms}}$	$V_{in} = 10 \text{ mV}_{\text{rms}}$ $V_{out} \approx 1.2 \text{ V}_{\text{rms}}$

Chapter 13:

Circuit	EWB	MultiSim
E13-01 Ideal = 1.63 V	$V_{UTP} = 1.76 \text{ V}$ $V_{LTP} = 1.66 \text{ V}$	$V_{UTP} = 1.7 \text{ V}$ $V_{LTP} = 1.5 \text{ V}$
E13-02 Ideal = $\pm 2.5 \text{ V}$	$V_{LTP} = -2.75 \text{ V}$ $V_{UTP} = 2.50 \text{ V}$	$V_{LTP} = -2.5 \text{ V}$ $V_{UTP} = 2.7 \text{ V}$
E13-03 Ideal = $\pm 2.54 \text{ V}$	$V_{LTP} = -2.61 \text{ V}$ $V_{UTP} = 2.55 \text{ V}$ $V_{out} = \pm 8 \text{ V}_P$	$V_{LTP} = -2.3 \text{ V}$ $V_{UTP} = 2.3 \text{ V}$ $V_{out} = \pm 7.4 \text{ V}_P$
E13-05	$V_{OUT} = -12.00 \text{ V}$	$V_{OUT} = -12.00 \text{ V}$
E13-06	$V_{OUT} = -6.999 \text{ V}$	$V_{OUT} = -7.000 \text{ V}$

E13-07	$V_{OUT} = -2.5000 \text{ V}$	$V_{OUT} = -2.5000 \text{ V}$
E13-08	$V_1 = 3.000 \text{ V}$ $V_2 = 2.000 \text{ V}$ $V_3 = 8.000 \text{ V}$ $V_{OUT} = -8.838 \text{ V}$	$V_1 = 3.000 \text{ V}$ $V_2 = 2.000 \text{ V}$ $V_3 = 8.000 \text{ V}$ $V_{OUT} = -8.838 \text{ V}$
E13-10	Integrator output $\Delta V/\Delta t = -5 \text{ V}/100 \mu\text{s}$	Integrator output $\Delta V/\Delta t = -5 \text{ V}/100 \mu\text{s}$
F13-52	$V_{LTP} = -2.93 \text{ V}$ $V_{UTP} = +2.90 \text{ V}$	$V_{LTP} = -3.1 \text{ V}$ $V_{UTP} = +3.0 \text{ V}$
F13-54a	$V_{LTP} = -4.0544 \text{ V}$ $V_{UTP} = 4.0812 \text{ V}$	$V_{LTP} = -4.1 \text{ V}$ $V_{UTP} = 4.0 \text{ V}$
F13-54b	$V_{LTP} = -3.212 \text{ V}$ $V_{UTP} = 3.2052 \text{ V}$	$V_{LTP} = -3.6 \text{ V}$ $V_{UTP} = 3.7 \text{ V}$
F13-55	$V_{LTP} = -1.05 \text{ V}$ $V_{UTP} = 1.05 \text{ V}$ $V_{out} = \pm 6.34 V_P$	$V_{LTP} = -1.2 \text{ V}$ $V_{UTP} = 1.2 \text{ V}$ $V_{out} = -4.3 V_P/+4.8 V_P$
F13-56a	$V_{OUT} = -2.50 \text{ V}$	$V_{OUT} = -2.50 \text{ V}$
F13-56b	$V_{OUT} = -3.520 \text{ V}$	$V_{OUT} = -3.520 \text{ V}$
F13-57	$V_{OUT} = -14.00 \text{ V}$	$V_{OUT} = -14.00 \text{ V}$
F13-58	$V_{OUT} = -3.572 \text{ V}$	$V_{OUT} = -3.572 \text{ V}$
F13-59	Integrator output $\Delta V/\Delta t = -4.42 \text{ V}/100 \mu\text{s}$	Integrator output $\Delta V/\Delta t = -4.5 \text{ V}/100 \mu\text{s}$
F13-60	$V_{out} = 200 \text{ mV}_{PP}$ square wave	$V_{out} = 200 \text{ mV}_{PP}$ square wave
TSE13-01	$V(-) = 2.000 \text{ V}$ $V_{OUT}$ is railed	$V(-) = 2.000 \text{ V}$ $V_{OUT}$ is railed
TSE13-02	$V_{IN} = 3\text{V}, 2\text{V}, 8\text{V}$ $V(-) = 6.682 \text{ V}$ $V_{OUT} = 6.682 \text{ V}$	$V_{IN} = 3\text{V}, 2\text{V}, 8\text{V}$ $V(-) = 6.682 \text{ V}$ $V_{OUT} = 6.682 \text{ V}$
TSE13-03	$V_{in} = 0\text{V}$ to $5\text{V}$ square wave $V_{out} = 0 \text{ V}$	$V_{in} = 0\text{V}$ to $5\text{V}$ square wave $V_{out} = 0 \text{ V}$
TSE13-04	$V_{in} = 20 V_{PP}$ triangle wave $V(-) = 0 \text{ V}$	$V_{in} = 20 V_{PP}$ triangle wave $V(-) = 0 \text{ V}$
TSE13-05	$V_{out}(\text{min}) = -1.07 \text{ V}$ $V_{out}(\text{max}) = +7.02 \text{ V}$	$V_{out}(\text{min}) = -834.4 \text{ V}$ $V_{out}(\text{max}) = +6.9 \text{ V}$
TSE13-06	Not implemented	0V ouptut
TSE13-07	$V_{LTP} = -2.61 \text{ V}$ $V_{UTP} = 2.55 \text{ V}$ $V_{out} = \pm 8 V_P$	$V_{LTP} = -2.3 \text{ V}$ $V_{UTP} = 2.5 \text{ V}$ $V_{out} = -7/7 V_P/+7.9 V_P$
TSE13-08	$V_{in} = 1 \text{ V}, 0.5 \text{ V}, 0.2\text{V}, 0.1 \text{ V}$ $V(-) = 450 \text{ mV}$ $V_{out}$ is railed negative	$V_{in} = 1 \text{ V}, 0.5 \text{ V}, 0.2\text{V}, 0.1 \text{ V}$ $V(-) = 0.450 \text{ V}$ $V_{out}$ is railed negative
TSE13-09	$V_{in} = 1 \text{ V}, 0.5 \text{ V}, 0.2\text{V}, 0.1 \text{ V}$ $V(-) = 500 \text{ mV}$ $V_{out}$ is railed negative	$V_{in} = 1 \text{ V}, 0.5 \text{ V}, 0.2\text{V}, 0.1 \text{ V}$ $V(-) = 0.500 \text{ V}$ $V_{out}$ is railed negative
TSP13-30	$V_{LTP} \approx 0 \text{ V}$ $V_{UTP} \approx 0 \text{ V}$	$V_{LTP} = -121.0 \text{ mV}$ $V_{UTP} = -10.5 \text{ mV}$
TSP13-31	$V_{LTP} \approx 0 \text{ V}$ $V_{UTP} \approx 0 \text{ V}$ $V_{out} = \pm 8 V_P$	$V_{LTP} = -30.2 \text{ mV}$ $V_{UTP} = -1.0 \text{ mV}$ $V_{out} = \pm 8.1 V_P$
TSP13-32	$V_{in} = 2.0 V_P$ $V_{out} = 2.0 V_P$	$V_{in} = 2.0 V_P$ $V_{out} = 2.0 V_P$
TSP13-33	$V_{out}(\text{min}) = -709 \text{ mV}$ $V_{out}(\text{max}) = +5.62 \text{ V}$	$V_{out}(\text{min}) = -913.9 \text{ mV}$ $V_{out}(\text{max}) = +5.5 \text{ V}$
TSP13-34	$V_{OUT} = -1.500 \text{ V}$	$V_{OUT} = -1.500 \text{ V}$
TSP13-35	$V(-) = 1.000 \text{ V}$ $V_{out}$ is railed negative	$V(-) = 1.000 \text{ V}$ $V_{out}$ is railed negative



TSP13-36	$V_{OUT} = -12.72 \text{ mV}$	$V_{OUT} = -0.013 \text{ V}$
TSP13-37	$V(-) = 2.433 \text{ V}$ $V_{out}$ is railed negative	$V(-) = 2.432 \text{ V}$ $V_{out}$ is railed negative
TSP13-38	$V_{out} = 0 \text{ V}$	$V_{out} = 2.804 \text{ V}$
TSP13-39	$V_{out} = 0 \text{ V}$	$V_{out} = 0.0 \text{ V}$

Chapter 14:

Circuit	EWB	MultiSim
E14-07 Ideal = 150 mV	$V_{OUT} = -155 \text{ mV}$	$V_{OUT} = -160.787 \text{ mV}$
F14-40	$V_{out} = 2.010 \text{ V}_{rms}$	$V_{out} = 2.013 \text{ V}_{rms}$
F14-47	$V_{OUT} = -162.4 \text{ mV}$	$V_{OUT} = -162.385 \text{ mV}$
F14-49a	$I_L = 4.7242 \text{ mA}$	$I_L = 4.624 \text{ mA}$
F14-49b	$I_L = 1.1765 \text{ mA}$	$I_L = 1.176 \text{ mA}$
TSP14-34	$V_{out} = 21.96 \text{ V}_{rms}$	$V_{out} = 22.003 \text{ V}_{rms}$
TSP14-35	$V(-) = 0.0000 \mu\text{V}$	$V(-) = -0.000 \text{ V}$
TSP14-36	$V(-) = 201.7 \text{ mV}$	$V(-) = 207.077 \text{ mV}$
TSP14-37	$I_L = 6.000 \text{ mA}$	$I_L = 6.000 \text{ mA}$
TSP14-38	$I_L = 594.1 \mu\text{A}$	$I_L = 594.058 \mu\text{A}$

Chapter 15:

Circuit	EWB	MultiSim
E15-03 Ideal = 7.69 kHz	$f_c \approx 7.8 \text{ kHz}$	$f_c \approx 7.7 \text{ kHz}$
E15-06	$f_c(1) \approx 650 \text{ Hz}$ $f_c(2) \approx 830 \text{ Hz}$	$f_c(1) \approx 634 \text{ Hz}$ $f_c(2) \approx 854 \text{ Hz}$
E15-07	$f_c(1) \approx 7.1 \text{ kHz}$ $f_c(2) \approx 7.3 \text{ kHz}$	$f_c(1) \approx 7.1 \text{ kHz}$ $f_c(2) \approx 7.3 \text{ kHz}$
E15-08	$f_c \approx 60.3 \text{ Hz}$	$f_c \approx 60.1 \text{ Hz}$
F15-32a	$f_c \approx 11.2 \text{ kHz}$	$f_c \approx 11.2 \text{ kHz}$
F15-32b	$f_c \approx 162 \text{ kHz}$	$f_c \approx 162 \text{ kHz}$
F15-32c	$f_c \approx 49 \text{ kHz}$	$f_c \approx 49 \text{ kHz}$
F15-34	$f_c(1) \approx 176 \text{ Hz}$ $f_c(2) \approx 200 \text{ Hz}$	$f_c(1) \approx 174 \text{ Hz}$ $f_c(2) \approx 200 \text{ Hz}$
F15-35	$f_c \approx 1.28 \text{ kHz}$	$f_c \approx 1.27 \text{ kHz}$
F15-36b	$f_c(1) \approx 405 \text{ Hz}$ $f_c(2) \approx 500 \text{ Hz}$	$f_c(1) \approx 402 \text{ Hz}$ $f_c(2) \approx 500 \text{ Hz}$
F15-36c	$f_{PEAK} \approx 15.99 \text{ kHz}$	$f_{PEAK} \approx 15.8 \text{ kHz}$
F15-37	$f_{NOTCH} \approx 1.325 \text{ kHz}$	$f_{NOTCH} \approx 1.316 \text{ kHz}$
TSP15-23	$I_{R4} = 0.000 \mu\text{A}_{rms}$ $V_{R4} = 432.5 \text{ mV}_{rms}$	$I_{R4} = 0.000 \mu\text{A}_{rms}$ $V_{R4} = 432.5 \text{ mV}_{rms}$
TSP15-24	$I_{R3} = 0.000 \mu\text{A}_{rms}$	$I_{R3} = 0.001 \text{ aA}_{rms}$
TSP15-25	$V(+)_2 = 0.001 \mu\text{V}_{rms}$	$V(+)_2 = 0.0322 \text{ pV}_{rms}$
TSP15-26	$f_c \approx 270 \text{ Hz}$	$f_c \approx 270 \text{ Hz}$
TSP15-27	$f_c \approx 2.48 \text{ kHz}$	$f_c \approx 2.45 \text{ kHz}$
TSP15-28	$V(+)_1 = 1.477 \mu\text{V}_{rms}$ $I_{R2} = 1.475 \text{ mV}_{rms}$	$V(+)_1 = 2.955 \text{ pV}_{rms}$ $I_{R2} = 1.479 \text{ mV}_{rms}$
TSP15-29	$V_S = 100 \text{ mV}_{rms}$ $V$ on end of R1 = 0 V	$V_S = 0.100 \text{ V}_{rms}$ $V$ on end of R1 = 0 V
TSP15-30	$V_{C2} = 100 \text{ mV}_{rms}$ $I_{C2} = 0.000 \mu\text{A}_{rms}$	$V_{C2} = 0.100 \text{ V}_{rms}$ $I_{C2} = 0.017 \mu\text{A}_{rms}$
TSP15-31	$V_{out}(2) = 36 \text{ mV}_{PP}$ $V(-)_3 = 0 \text{ V}$	$V_{out}(2) = 36.7 \text{ mV}_{PP}$ $V(-)_3 = 0 \text{ V}$

Chapter 16:

Circuit	EWB	MultiSim
E16-01	$V_{out} \approx 2 V_{pp} @ 1.51 \text{ kHz}$	$V_{out} \approx 2.2 V_{pp} @ 1.45 \text{ kHz}$
E16-02	$V_{out} \approx 1.05 V_{pp} @ 6.43 \text{ kHz}$	$V_{out} \approx 1.06 V_{pp} @ 6.56 \text{ kHz}$
E16-04 Ideal = 8.25 kHz	$V_{out} \approx 12.5 V_{pp} @ 7.6 \text{ kHz}$ triangle wave	Not implemented
F16-50	$V_{out} \approx 2.16 V_{pp} @ 11.8 \text{ kHz}$	$V_{out} \approx 2.2 V_{pp} @ 9.11 \text{ kHz}$
F16-51	$V_{out} \approx 1.03 V_{pp} @ 688 \text{ Hz}$	$V_{out} \approx 13.4 V_{pp} @ 694 \text{ Hz}$
F16-52a	$V_{out} \approx 580 \text{ mV}_{pp} @ 217 \text{ kHz}$	$V_{out} \approx 700 \text{ mV}_{pp} @ 87.7 \text{ kHz}$ Unstable
F16-52b	$V_{out} \approx 4.34 V_{pp} @ 60.0 \text{ kHz}$	$V_{out} \approx 4.2 V_{pp} @ 59.5 \text{ kHz}$
F16-54	$V_{out} \approx 12.3 V_{pp} @ 1.64 \text{ kHz}$	$V_{out} \approx 12.0 V_{pp} @ 1.53 \text{ kHz}$
F16-56	$t_H = 141.3 \mu\text{s}$ $t_L = 107.6 \mu\text{s}$ $f = 4.02 \text{ kHz}$	$t_H = 141.2 \mu\text{s}$ $t_L = 108.9 \mu\text{s}$ $f = 4.00 \text{ kHz}$
TSP16-23	$R_{DS} = 0.0000 \Omega$	$R_{DS} = 0.000 \Omega$
TSP16-24	$V_{C3}$ open from oscilloscope trace	$V_{C3}$ open from oscilloscope trace
TSP16-25	$V_{CE} = 0.000 \mu\text{V}_{DC}$	$V_{CE} < 1 \text{ pV}_{DC}$
TSP16-26	$V_{R1} = 8.442 \text{ V}_{DC}$	$V_{R1} = 8.442 \text{ V}_{DC}$
TSP16-27	R2 is open	$R2 = 999.999 \text{ G}\Omega$
TSP16-28	$t_H = 112.3 \mu\text{s}$ $t_L = 108.4 \mu\text{s}$	$t_H = 109.4 \mu\text{s}$ $t_L = 111.7 \mu\text{s}$

Chapter 18:

Circuit	EWB	MultiSim
E18-03 Ideal = 10.2 V	$V_{OUT} = 10.32 \text{ V}$	$V_{OUT} = 10.342 \text{ V}$
E18-05	$V_{OUT} = 10.32 \text{ V}$	$V_{OUT} = 10.340 \text{ V}$
F18-45	$V_{OUT} = 10.62 \text{ V}$	$V_{OUT} = 10.625 \text{ V}$
F18-46	$V_{OUT} = 8.505 \text{ V}$	$V_{OUT} = 8.757 \text{ V}$
F18-47	$V_{R2} = 352.7 \text{ mV}$ $I_{R4} = 125.8 \text{ mA}$ $I_{Q2} = 0.207 \mu\text{A}$ $I_L = 125.1 \text{ mA}$ $V_{OUT} = 9.383 \text{ V}$	$V_{R2} = 0.354 \text{ V}$ $I_{R4} = 0.126 \text{ A}$ $I_{Q2} < 1 \mu\text{A}$ $I_L = 0.126 \text{ mA}$ $V_{OUT} = 9.424 \text{ V}$
F18-48	$I_L = 35.45 \text{ mA}$	$I_L = 0.037 \text{ mA}$
TSP18-31	$V_{R3} = 2.471 \text{ V}$ $V_{OUT} = 2.496 \text{ V}$	$V_{R3} = 2.497 \text{ V}$ $V_{OUT} = 2.472 \text{ V}$
TSP18-32	$V_Z = 11.88 \text{ V}$ $V_{OUT} = 12.00 \text{ V}$	$V_Z = 11.881 \text{ V}$ $V_{OUT} = 11.992 \text{ V}$
TSP18-33	$V_{R2} = 352.2 \text{ mV}$ $I_{R4} = 125.8 \text{ mA}$ $I_{Q2} = 0.0000 \mu\text{A}$ $I_L = 125.1 \text{ mA}$ $V_{OUT} = 9.383 \text{ V}$	$V_{R2} = 0.353 \text{ V}$ $I_{R4} = 0.126 \text{ A}$ $I_{Q2} < 2 \mu\text{A}$ $I_L = 0.126 \text{ A}$ $V_{OUT} = 9.419 \text{ V}$
TSP18-34	$V_{R1} = 24.99 \text{ V}$ $I_L = 24.12 \mu\text{A}$	$V_{R1} = 24.99 \text{ V}$ $I_L = 0.019 \text{ mA}$

# **Test Item File**

**Prepared by Kenneth Lawell**



## Chapter 1: Introduction to Semiconductors

### *MULTIPLE CHOICE*

1. A molecule is the smallest particle of an element that retains the characteristics of that element.
  - a) true
  - b) false
2. A forward-biased diode of a conducting germanium diode has a potential of about 0.7 V across it.
  - a) true
  - b) false
3. Silicon doped with impurities is used in the manufacture of semiconductor devices.
  - a) true
  - b) false
4. Reverse bias permits full current through a PN junction.
  - a) true
  - b) false
5. Semiconductor material of the P-type has few free electrons.
  - a) true
  - b) false
6. The dc voltages for a device to operate properly is called:
  - a) rectification
  - b) amplification
  - c) bias
  - d) a PN junction
7. The majority carriers are the holes in a(n):
  - a) N-type semiconductor
  - b) P-type semiconductor
  - c) PN junction semiconductor
  - d) none of the above
8. Semiconductor materials are those with:
  - a) conductive properties that are in between those of a conductor or an insulator
  - b) conductive properties that are very good
  - c) no conductive properties
  - d) a or b
9. A current flows across the junction of a forward-biased diode. This current is called:
  - a) forward-bias current
  - b) reverse breakdown current
  - c) conventional current
  - d) reverse leakage current

## Chapter 1: Introduction to Semiconductors

10. A large current that flows in the opposite direction across a PN junction is called:
  - a) forward-bias current
  - b) reverse breakdown current
  - c) conventional current
  - d) reverse leakage current
11. A small current that flows when a diode is reverse biased is called:
  - a) forward-bias current
  - b) reverse breakdown current
  - c) conventional current
  - d) reverse-leakage current
12. As the forward current through a forward-biased diode decreases, the voltage across the diode:
  - a) increases
  - b) decreases
  - c) is relatively constant
  - d) increases and then decreases
13. Which statement best describes a semiconductor?
  - a) A material with many free electrons.
  - b) A material doped to have some free electrons.
  - c) A material with few free electrons.
  - d) None of these.
14. As the forward current through a silicon diode decreases, the internal resistance of the diode will:
  - a) increase
  - b) decrease
  - c) remain the same
  - d) either b or c
15. A silicon diode measures a high value of resistance with the meter leads in both positions. The trouble, if any, is:
  - a) the diode is open
  - b) the diode is shorted to ground
  - c) the diode is internally shorted
  - d) the diode is ok
16. A silicon diode is reverse biased. The voltage measured to ground from the anode is \_\_\_\_\_, and the voltage to ground from the anode is \_\_\_\_\_.
  - a) 16 V, 15.3 V
  - b) -16 V, -16.7 V
  - c) 0.2 V, -0.5 V
  - d) 15.3 V, 16 V
17. The forward voltage across a conducting silicon diode is about:
  - a) 1.3 V
  - b) 0.3 V
  - c) 0.7 V
  - d) -0.3 V

18. To change ac to pulsating dc, the best type of diode to use might be:
- a) a Shockley diode
  - b) a Zener diode
  - c) a rectifier diode
  - d) a photodiode
19. An unknown type diode is in a circuit. The voltage measured across it was found to be 0.3 V. The diode is:
- a) a silicon diode
  - b) a germanium diode
  - c) a transistor
  - d) none of the above
20. A reverse-biased diode has the \_\_\_\_\_ connected to the positive side of the source, and the \_\_\_\_\_ connected towards the negative side of the source.
- a) cathode, anode
  - b) cathode, base
  - c) base, anode
  - d) anode, cathode
21. A silicon diode is forward biased. You measure the voltage to ground from the anode at \_\_\_\_\_ V, and the voltage from the cathode to ground at \_\_\_\_\_ V.
- a) 16, 32
  - b) 2.3, 1.6
  - c) 1.6, 2.3
  - d) 0.3, 0
22. The boundary between p-type material and n-type material is called:
- a) a diode
  - b) a reverse-biased diode
  - c) a PN junction
  - d) a forward-biased diode
23. The Atomic number of an atom refers to the:
- a) number of protons in the nucleus
  - b) number of electrons in a charged atom
  - c) net electrical charge of the atom
  - d) number of neutrons in the nucleus
24. Electrons orbiting the nucleus of an atom are grouped into energy bands known as:
- a) orbits
  - b) tracks
  - c) shells
  - d) tunnels
25. Valence electrons have the \_\_\_\_\_ energy level of all the electrons in orbit around the nucleus of a given atom.
- a) lowest
  - b) highest
  - c) same
  - d) none of the above

**Chapter 1: Introduction to Semiconductors**

26. The difference in energy levels that exists between the valence band and the conduction band is called:
  - a) co-valent gap
  - b) semi-conductor region
  - c) Thermal energy gap
  - d) energy gap
  
27. The valence electron of a copper atom experiences what kind of attraction toward the nucleus?
  - a) None
  - b) Weak
  - c) Strong
  - d) Impossible to say
  
28. Which of the following cannot actually move?
  - a) Holes
  - b) Free electrons
  - c) Ions
  - d) Majority carriers
  
29. Reverse bias is a condition that essentially \_\_\_\_\_ current through the diode.
  - a) prevents
  - b) allows
  - c) increases
  - d) blocks
  
30. The knee voltage of a diode is approximately equal to the:
  - a) applied voltage
  - b) barrier potential
  - c) breakdown voltage
  - d) forward voltage
  
31. How is a non-conducting diode biased?
  - a) Forward
  - b) Inverse
  - c) Poorly
  - d) Reverse
  
32. What kind of a device is a diode?
  - a) Bilateral
  - b) Linear
  - c) Nonlinear
  - d) Unipolar
  
33. How much forward diode voltage is there with the ideal-diode approximation?
  - a) 0 V
  - b) 0.7 V
  - c) More than 0.7 V
  - d) 1 V



34. The dynamic resistance  $r'_d$  of a forward biased PN junction diode is smallest:
- a) below the knee
  - b) above the knee
  - c) in the breakdown region
  - d) in cutoff
35. If the positive lead of an ohmmeter is placed on the cathode and the negative lead is placed on the anode, which of the following readings would indicate a defective diode?
- a)  $0\Omega$
  - b)  $\infty\Omega$
  - c)  $50\Omega$
  - d)  $1\text{ K}\Omega$

## **Chapter 1: Introduction to Semiconductors**

1. Answer: b Difficulty: 2
2. Answer: b Difficulty: 2
3. Answer: a Difficulty: 2
4. Answer: b Difficulty: 2
5. Answer: a Difficulty: 2
6. Answer: c Difficulty: 2
7. Answer: a Difficulty: 2
8. Answer: a Difficulty: 2
9. Answer: a Difficulty: 2
10. Answer: b Difficulty: 2
11. Answer: d Difficulty: 2
12. Answer: c Difficulty: 2
13. Answer: b Difficulty: 2
14. Answer: a Difficulty: 2
15. Answer: a Difficulty: 2
16. Answer: d Difficulty: 3
17. Answer: c Difficulty: 2
18. Answer: c Difficulty: 2
19. Answer: b Difficulty: 2
20. Answer: a Difficulty: 3
21. Answer: b Difficulty: 3
22. Answer: c Difficulty: 2
23. Answer: a Difficulty: 1 Section: 1
24. Answer: c Difficulty: 2 Section: 1
25. Answer: b Difficulty: 2 Section: 1

- 26. Answer: d Difficulty: 3 Section: 2
- 27. Answer: b Difficulty: 2 Section: 1
- 28. Answer: a Difficulty: 2 Section: 7
- 29. Answer: a Difficulty: 2 Section: 7
- 30. Answer: b Difficulty: 2 Section: 8
- 31. Answer: d Difficulty: 2 Section: 7
- 32. Answer: c Difficulty: 1 Section: 8
- 33. Answer: a Difficulty: 1 Section: 9
- 34. Answer: a Difficulty: 3 Section: 8
- 35. Answer: a Difficulty: 3 Section: 10

## Chapter 2: Diode Applications

### MULTIPLE CHOICE

1. A diode conducts currents when forward biased and blocks current when reverse biased.
  - a) true
  - b) false
2. The larger the ripple voltage, the better the filter.
  - a) true
  - b) false
3. Clamping circuits use capacitors and diodes to add a dc level to a waveform.
  - a) true
  - b) false
4. The diode in a half-wave rectifier conducts for \_\_\_\_\_ of the input cycle.
  - a)  $0^\circ$
  - b)  $45^\circ$
  - c)  $90^\circ$
  - d)  $180^\circ$
5. A full-wave bridge rectifier uses \_\_\_\_\_ diode(s) in a bridge circuit.
  - a) 1
  - b) 2
  - c) 3
  - d) 4
6. A silicon diode is connected in series with  $10\text{ k}\Omega$  resistor and a  $12\text{ V}$  battery. If the cathode of the diode is connected to the positive terminal of the battery, the voltage from the anode to the negative terminal of the battery is:
  - a)  $0\text{ V}$
  - b)  $0.7\text{ V}$
  - c)  $11.3\text{ V}$
  - d)  $12\text{ V}$

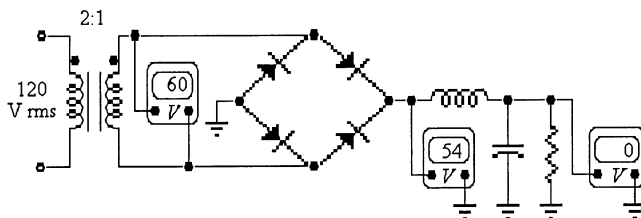

Figure 2-1

7. Refer to Figure 2-1. If the voltmeter across the transformer secondary reads 0 V, the probable trouble, if any, would be:
- one of the diodes is open
  - the filter capacitor is shorted
  - the transformer secondary is open
  - the inductor is open
  - everything is normal
8. Refer to Figure 2-1. In servicing this power supply, you notice that the ripple voltage is higher than normal and that the ripple frequency has changed to 60 Hz. The probable trouble is:
- the filter capacitor has opened
  - the inductor has opened
  - a diode has shorted
  - a diode has opened



Figure 2-2

9. Refer to Figure 2-2 (a). This oscilloscope trace indicates the output from:
- a half-wave filtered rectifier
  - a full-wave rectifier with no filter and an open diode
  - a full-wave filtered rectifier
  - a full-wave filtered rectifier with an open diode
10. Refer to Figure 2-2 (b). The trace on this oscilloscope indicates the output from:
- a half-wave rectifier with no filter
  - a full-wave rectifier with no filter
  - a full-wave filtered rectifier
  - a full-wave filtered rectifier with an open diode
11. Refer to Figure 2-2 (c). This is the output from:
- a half-wave rectifier with no filter
  - a full-wave rectifier with no filter and an open diode
  - a full-wave filtered rectifier
  - a full-wave filtered rectifier with an open diode
12. Refer to Figure 2-2 (d). This trace shows the output from:
- a half-wave rectifier with no filter
  - a full-wave rectifier with no filter and an open diode
  - a full-wave filtered rectifier
  - a full-wave filtered rectifier with an open diode

Chapter 2: Diode Applications

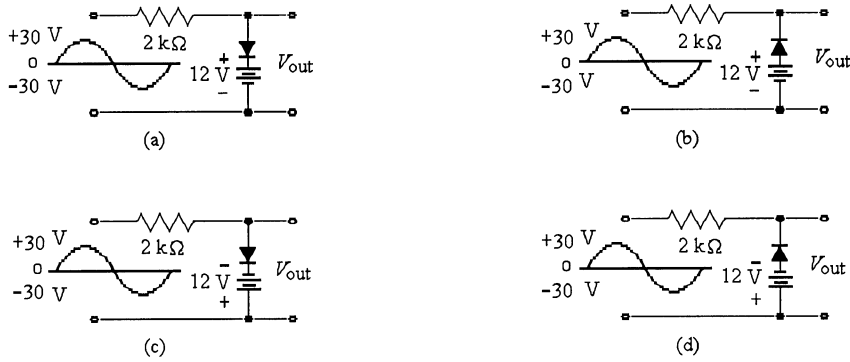

Figure 2-3

13. Refer to Figure 2-3. These circuits are known as:
- a) amplifiers
  - b) clippers
  - c) clampers
  - d) rectifiers

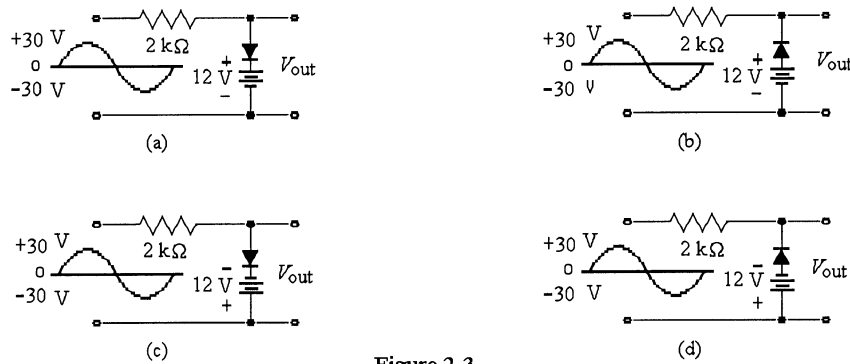

Figure 2-3

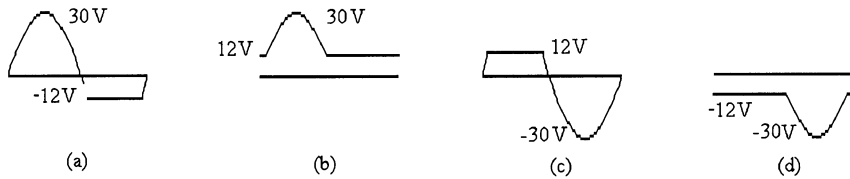

Figure 2-4

14. Which of the circuits in Figure 2-3 will produce the signal in Figure 2-4?
- a) (a)
  - b) (b)
  - c) (c)
  - d) (d)
15. Which of the circuits in Figure 2-3 will produce the signal in Figure 2-4 (b)?
- a) (a)
  - b) (b)
  - c) (c)
  - d) (d)

16. Which of the circuits in Figure 2-3 will produce the signal in Figure 2-4 (c)?  
 a) (a)  
 b) (b)  
 c) (c)  
 d) (d)
17. Which of the circuits in Figure 2-3 will produce the signal in Figure 2-4 (d)?  
 a) (a)  
 b) (b)  
 c) (c)  
 d) (d)

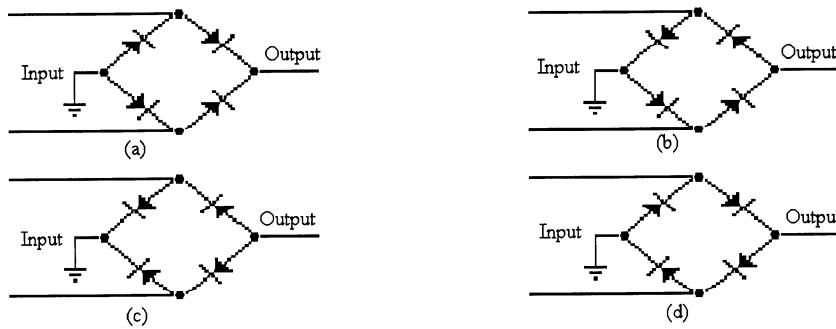

Figure 2-5

18. Refer to Figure 2-5 (c). This rectifier arrangement:  
 a) will produce a positive output voltage  
 b) will produce a negative output voltage  
 c) is incorrectly connected  
 d) a or c
19. Refer to Figure 2-5 (d). This rectifier arrangement:  
 a) will produce a positive output voltage  
 b) will produce a negative output voltage  
 c) is incorrectly connected  
 d) none of the above
20. A silicon diode has a voltage to ground of 117 V from the anode. The voltage to ground from the cathode is 117.7 V. The diode is:  
 a) open  
 b) shorted  
 c) forward biased  
 d) reverse biased

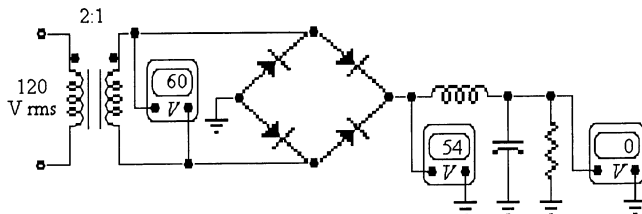

Figure 2-1

**Chapter 2: Diode Applications**

21. Refer to Figure 2-1. The probable trouble, if any, indicated by these voltages:
- a) is one of the diodes is open
  - b) is a diode is shorted
  - c) is an open transformer secondary
  - d) is the filter capacitor is shorted
  - e) is no trouble exists
22. Refer to Figure 2-1. If the voltmeter across the transformer reads 0 V, the probable trouble, if any, would be:
- a) one of the diodes is open
  - b) is an open transformer secondary
  - c) is the filter capacitor is shorted
  - d) no trouble exists



**Figure 2-2**

23. Refer to Figure 2-2. Which oscilloscope trace indicates the output from a full-wave rectifier with an open diode?
- a) (a)
  - b) (b)
  - c) (c)
  - d) (d)
24. The ripple frequency of a bridge rectifier is:
- a) the same as the input frequency
  - b) double the input frequency
  - c) four times the input frequency
  - d) cannot be determined

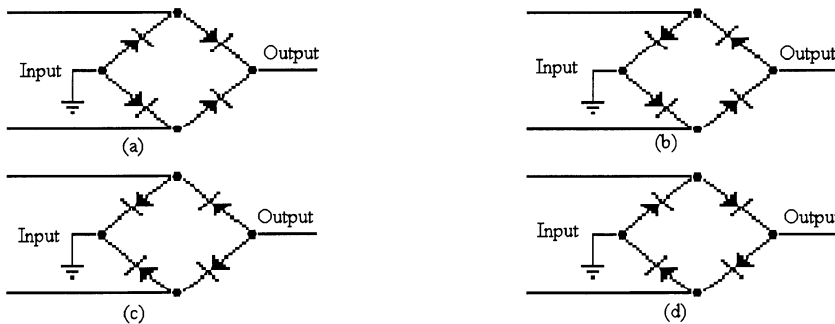

**Figure 2-5**



25. Refer to Figure 2-5. Which diode arrangement is correct to supply a positive output voltage?
- a) (a)
  - b) (b)
  - c) (c)
  - d) (d)
26. With a half-wave rectified voltage across the load resistor, load current flows for what part of a cycle?
- a) 0 degrees
  - b) 90 degrees
  - c) 180 degrees
  - d) 360 degrees
27. When a 60 Hz sinusoidal signal voltage is applied to the input of a half-wave rectifier, the output frequency is:
- a) 120 Hz
  - b) 60 Hz
  - c) 30 Hz
  - d) 90 Hz
28. The average value of the half-wave rectified output voltage is approximately \_\_\_\_\_ of  $V_p$ .
- a) 31.8%
  - b) 63.6%
  - c) 70.7%
  - d) 100%
29. Using a practical diode as a model, what would  $V_{p(out)}$  equal if  $V_{p(in)}$  was 10 VAC?
- a) 10 VAC
  - b) 9.3 VAC
  - c) 10.7 VAC
  - d) 10.3 VAC
30. One of the advantages of using transformer coupling in a half-wave rectifier is that it allows the ac source to be directly connected to the load.
- a) true
  - b) false
31. If input frequency is 60 Hz, the output frequency of a bridge rectifier is:
- a) 30 Hz
  - b) 60 Hz
  - c) 120 Hz
  - d) 240 Hz
32. To obtain an output voltage with a peak equal to the input peak (minus .7V), what type of transformer and turns ratio is needed?
- a) Step-down/turns ratio = 2
  - b) Step-down/turns ratio = 4
  - c) Step-up/turns ratio = 2
  - d) Step-up/turns ratio = 4

## Chapter 2: Diode Applications

33. The dc current through each diode in a bridge rectifier equals:
  - a) twice the dc load current
  - b) half the dc load current
  - c) the load current
  - d) one-fourth the dc load current
  
34. The peak inverse voltage across a nonconducting diode in a bridge rectifier that equals approximately:
  - a) half the peak secondary voltage
  - b) twice the peak secondary voltage
  - c) the peak value of the secondary voltage
  - d) four times the peak value of the secondary voltage
  
35. The PIV rating of a diode in a full-wave bridge rectifier is more than that required for a full-wave center-tapped configuration.
  - a) true
  - b) false
  
36. The ideal dc output voltage of a capacitor-input filter equals the:
  - a) rms value of the rectified voltage
  - b) peak value of the rectified voltage
  - c) average value of the rectified voltage
  - d) peak-to-peak value of the secondary voltage
  
37. A filtered full-wave rectifier voltage has a smaller ripple than does a half-wave rectifier voltage for the same load resistance and capacitor values because:
  - a) shorter time between peaks
  - b) longer time between peaks
  - c) the larger the ripple, the better the filtering action
  - d) none of the above
  
38. If the output of a voltage regulator varies from 20 to 19.8 V when the line voltage varies over its specified range, the source regulation is:
  - a) 0%
  - b) 1%
  - c) 2%
  - d) 5%
  
39. Thermal shutdown occurs in an IC regulator if:
  - a) power dissipation is too high
  - b) internal temperature is too high
  - c) current through the device is too high
  - d) all the above occur
  
40. The efficiency of a voltage regulator is high when:
  - a) input power is low
  - b) output power is high
  - c) little power is wasted
  - d) input power is high

41. An increase of line voltage into a power supply usually produces:
- a) a decrease in load resistance
  - b) an increase in load voltage
  - c) a decrease in efficiency
  - d) less power dissipation in the rectifier diodes
42. A diode clamper will:
- a) clip off a portion of the input signal
  - b) eliminate the positive or negative alternation of a signal
  - c) add an ac voltage to a signal
  - d) add a dc voltage to a signal
43. Voltage multipliers use \_\_\_\_\_ action to increase peak rectified voltages without the necessity of increasing the input transformer voltage rating.
- a) clipping
  - b) clamping
  - c) charging
  - d) cropping
44. Which of the following diode information **is not** provided by a manufacturer's datasheet?
- a) Frequency response
  - b) PIV ratings
  - c) Mechanical data
  - d) Temperature parameters
45. The complete trouble-shooting process contains how many steps?
- a) 4
  - b) 5
  - c) 6
  - d) 7

## **Chapter 2: Diode Applications**

1. Answer: a Difficulty: 2
2. Answer: b Difficulty: 2
3. Answer: a Difficulty: 2
4. Answer: d Difficulty: 2
5. Answer: d Difficulty: 2
6. Answer: a Difficulty: 3
7. Answer: c Difficulty: 3
8. Answer: d Difficulty: 3
9. Answer: b Difficulty: 3
10. Answer: a Difficulty: 3
11. Answer: c Difficulty: 3
12. Answer: d Difficulty: 3
13. Answer: b Difficulty: 2
14. Answer: d Difficulty: 2
15. Answer: b Difficulty: 2
16. Answer: a Difficulty: 2
17. Answer: c Difficulty: 2
18. Answer: b Difficulty: 2
19. Answer: c Difficulty: 2
20. Answer: d Difficulty: 2
21. Answer: d Difficulty: 3
22. Answer: c Difficulty: 3
23. Answer: d Difficulty: 3
24. Answer: b Difficulty: 2
25. Answer: a Difficulty: 2

- 26. Answer: c Difficulty: 2 Section: 1
- 27. Answer: b Difficulty: 1 Section: 1
- 28. Answer: a Difficulty: 2 Section: 1
- 29. Answer: b Difficulty: 3 Section: 1
- 30. Answer: b Difficulty: 2 Section: 1
- 31. Answer: c Difficulty: 1 Section: 2
- 32. Answer: c Difficulty: 4 Section: 2
- 33. Answer: c Difficulty: 3 Section: 2
- 34. Answer: c Difficulty: 4 Section: 2
- 35. Answer: b Difficulty: 2 Section: 2
- 36. Answer: b Difficulty: 3 Section: 3
- 37. Answer: a Difficulty: 3 Section: 3
- 38. Answer: b Difficulty: 2 Section: 3
- 39. Answer: b Difficulty: 1 Section: 3
- 40. Answer: c Difficulty: 2 Section: 3
- 41. Answer: b Difficulty: 2 Section: 3
- 42. Answer: d Difficulty: 3 Section: 4
- 43. Answer: b Difficulty: 3 Section: 5
- 44. Answer: a Difficulty: 4 Section: 6
- 45. Answer: c Difficulty: 1 Section: 7

## Chapter 3: Special-Purpose Diodes

### MULTIPLE CHOICE

1. The regulating ability of a Zener diode depends upon its ability to operate in a breakdown condition.  
a) true  
b) false
2. Dark Current is the amount of thermally generated forward current in a photodiode in the absence of light.  
a) true  
b) false
3. A \_\_\_\_\_ diode maintains a constant voltage across it when operating in the breakdown condition.  
a) silicon  
b) germanium  
c) Zener  
d) none of the above
4. A tunnel diode has \_\_\_\_\_ characteristic(s).  
a) an extremely narrow depletion region  
b) a negative resistance  
c) no breakdown effect  
d) all of the above
5. Typically, the maximum  $V_F$  for an LED is between:  
a) 0 V and 1 V  
b) 1 V and 1.2 V  
c) 1.2 V and 3.2 V  
d) 3.2 V and 4 V
6. A 5.1 V Zener has a resistance of  $8\ \Omega$ . The actual voltage across its terminals when the current is 20 mA is:  
a) 5.1 V  
b) 100 mV  
c) 5.26 V  
d) 4.94 V

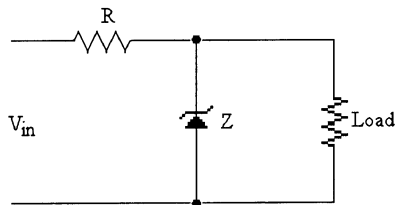

Figure 3-1

7. Refer to Figure 3-1. If  $V_{in}$  increases,  $V_R$  will:  
a) increase  
b) decrease  
c) remain the same  
d) cannot be determined

8. Refer to Figure 3-1. If  $V_{RL}$  increases,  $I_Z$  will:
  - a) increase
  - b) decrease
  - c) remain the same
  - d) cannot be determined
  
9. Refer to Figure 3-1. Measurements show that  $V_{RL}$  has increased. Which of the following faults, if any, could have caused this problem?
  - a) R opens
  - b) The Zener shorts
  - c)  $V_{in}$  has decreased
  - d) The Zener opens
  
10. Refer to Figure 3-1. If  $V_{RL}$  attempts to decrease,  $I_R$  will:
  - a) increase
  - b) decrease
  - c) remain the same
  - d) cannot be determined
  
11. Refer to Figure 3-1. If the load current increases,  $I_R$  will \_\_\_\_\_ and  $I_Z$  will \_\_\_\_\_.
  - a) remain the same, increase
  - b) decrease, remain the same
  - c) increase, remain the same
  - d) remain the same, decrease
  
12. Refer to Figure 3-1. If  $V_{in}$  decreases,  $I_R$  will:
  - a) increase
  - b) decrease
  - c) remain the same
  - d) cannot be determined

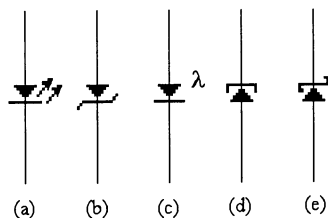

Figure 3-2

13. Refer to Figure 3-2 (a). The symbol is for:
  - a) a Zener diode
  - b) an LED
  - c) a Schottky diode
  - d) a photodiode
  - e) a tunnel diode

### Chapter 3: Special-Purpose Diodes

14. Refer to Figure 3-2 (b). The symbol is for:
  - a) a Zener diode
  - b) an LED
  - c) a Schottky diode
  - d) a photodiode
  - e) a tunnel diode
  
15. Refer to Figure 3-2 (c). The symbol is for:
  - a) a zener diode
  - b) an LED
  - c) a Schottky diode
  - d) a photodiode
  - e) a tunnel diode
  
16. Refer to Figure 3-2 (d). The symbol is for:
  - a) a Zener diode
  - b) an LED
  - c) a Schottky diode
  - d) a photodiode
  - e) a tunnel diode
  
17. Refer to Figure 3-2 (e). The symbol is for:
  - a) a Zener diode
  - b) an LED
  - c) a Schottky diode
  - d) a photodiode
  - e) a tunnel diode
  
18. A varactor is a diode that:
  - a) varies its resistance with temperature
  - b) changes its capacitance with voltage
  - c) emits light when forward biased
  - d) switches very fast
  - e) exhibits an increase in reverse current with light intensity
  
19. A Schottky diode is a diode that:
  - a) varies its resistance with temperature
  - b) changes its capacitance with voltage
  - c) emits light when forward biased
  - d) switches very fast
  - e) exhibits an increase in reverse current with light intensity
  
20. A photodiode is a diode that:
  - a) varies its resistance with temperature
  - b) changes its capacitance with voltage
  - c) emits light when forward biased
  - d) switches very fast
  - e) exhibits an increase in reverse current with light intensity



21. An LED is being tested by placing it in a forward bias position across a 5 V dc supply. The correct conclusion would be:
  - a) nothing is wrong with the LED, go ahead and use it
  - b) your test was correct, but the LED was bad
  - c) your test was incorrect, and the LED is now bad
  - d) there is no way to test the LED. Put in a new one
  
22. A diode with a negative-resistance characteristic is needed. A correct selection might be:
  - a) a tunnel diode
  - b) a Gunn diode
  - c) a varactor diode
  - d) a Schottky diode
  
23. A 6.2 V Zener is rated at 1 watt. The maximum safe current the Zener can carry is:
  - a) 1.61 A
  - b) 161 mA
  - c) 16.1 mA
  - d) 1.61 mA
  
24. An LED is forward biased. The diode should be on, but no light is showing. A possible problem might be:
  - a) the diode is open
  - b) the series resistor is too small
  - c) none, the diode should be off if forward biased
  - d) the power supply voltage is too high
  
25. The best type of diodes to use in a turning circuit is:
  - a) an LED
  - b) a Schottky diode
  - c) a Gunn diode
  - d) a varactor
  
26. What is true about the breakdown voltage in a Zener diode?
  - a) It decreases when current increases
  - b) It destroys the diode
  - c) It equals the current times the resistance
  - d) It is approximately constant
  
27. Two types of reverse breakdown in a Zener diode are:
  - a) avalanche and Zener
  - b) avalanche and reverse
  - c) avalanche and forward
  - d) charge and discharge
  
28. If the load current increases in a Zener regulator:
  - a) the series current increases
  - b) the series current remains the same
  - c) the Zener current increases
  - d) both b and c above

### Chapter 3: Special-Purpose Diodes

29. For Zener diodes, the temperature coefficient is:
- always positive
  - always negative
  - negative for breakdown voltages less than 5 V and positive for breakdown voltages greater than 6 V
  - always zero
30. Data sheets for Zener diodes usually specify the Zener voltage at a particular test current designated:
- $I_S$
  - $I_{ZK}$
  - $I_{ZM}$
  - $I_{ZT}$
31. When the source voltage increases in a Zener regulator, which of these currents remains approximately constant?
- Series current
  - Zener current
  - Load current
  - Total current
32. If the load resistance decreases in a Zener regulator, the Zener current:
- decreases
  - stays the same
  - increases
  - equals the source voltage divided by the series resistance
33. If the load resistance decreases in a Zener regulator, the series current:
- decreases
  - stays the same
  - Increases
  - equals the source voltage divided by the series resistance
34. The varactor is usually:
- forward biased
  - reverse biased
  - unbiased
  - operated in the breakdown region
35. The capacitance of a varactor diode:
- remains constant as the bias voltage varies
  - decreases as the reverse bias voltage increases
  - increases as the reverse bias voltage increases
  - is usually 1000  $\mu\text{F}$  or more
36. A photodiode is normally:
- reverse biased
  - forward biased
  - not biased
  - used to regulate voltage

37. When the light increases, the reverse minority carrier current in a photodiode:
- a) decreases
  - b) increases
  - c) is unaffected
  - d) reverses direction
38. A blown-fuse indicator uses a:
- a) Zener diode
  - b) constant-current diode
  - c) light-emitting diode
  - d) back diode
39. To display the digit 8 in a seven-segment indicator:
- a) C must be lighted
  - b) G must be off
  - c) F must be on
  - d) all segments must be on
40. Typically the forward voltage on an LED is between:
- a) 1.2 to 3.2 V
  - b) 0.7 to 1.1 V
  - c) 1.5V to 3.7 V
  - d) 1 to 6 V
41. A Schottky diode:
- a) has a forward voltage drop of about 2 V
  - b) has no limit on maximum current
  - c) has no charge storage
  - d) cannot operate properly at high frequencies
42. The PIN diode, when reverse biased acts like a nearly constant
- 
- a) resistance
  - b) capacitance
  - c) voltage source
  - d) current source
43. Which of the following has a negative-resistance region?
- a) Tunnel diode
  - b) Step-recovery diode
  - c) Schottky diode
  - d) Optocoupler
44. When Laser diodes are operating above their threshold level of current, they produce:
- a) incoherent light
  - b) coherent light
  - c) high frequency
  - d) none of the above

**Chapter 3: Special-Purpose Diodes**

45. When the reverse voltage increases, the capacitance:
- a) decreases
  - b) stays the same
  - c) increases
  - d) has more bandwidth

1. Answer: a Difficulty: 2
2. Answer: b Difficulty: 2
3. Answer: c Difficulty: 2
4. Answer: b Difficulty: 2
5. Answer: c Difficulty: 2
6. Answer: a Difficulty: 2
7. Answer: a Difficulty: 3
8. Answer: a Difficulty: 3
9. Answer: d Difficulty: 3
10. Answer: c Difficulty: 2
11. Answer: b Difficulty: 3
12. Answer: b Difficulty: 2
13. Answer: b Difficulty: 2
14. Answer: a Difficulty: 2
15. Answer: d Difficulty: 2
16. Answer: e Difficulty: 2
17. Answer: c Difficulty: 2
18. Answer: b Difficulty: 2
19. Answer: d Difficulty: 2
20. Answer: e Difficulty: 2
21. Answer: c Difficulty: 3
22. Answer: a Difficulty: 2
23. Answer: b Difficulty: 2
24. Answer: a Difficulty: 3
25. Answer: d Difficulty: 2

**Chapter 3: Special-Purpose Diodes**

- 26. Answer: d Difficulty: 2 Section: 1
- 27. Answer: a Difficulty: 2 Section: 1
- 28. Answer: b Difficulty: 3 Section: 1
- 29. Answer: c Difficulty: 2 Section: 1
- 30. Answer: d Difficulty: 1 Section: 1
- 31. Answer: c Difficulty: 3 Section: 2
- 32. Answer: a Difficulty: 2 Section: 2
- 33. Answer: b Difficulty: 2 Section: 2
- 34. Answer: b Difficulty: 2 Section: 3
- 35. Answer: b Difficulty: 3 Section: 3
- 36. Answer: c Difficulty: 2 Section: 4
- 37. Answer: b Difficulty: 1 Section: 4
- 38. Answer: d Difficulty: 1 Section: 4
- 39. Answer: d Difficulty: 2 Section: 4
- 40. Answer: a Difficulty: 2 Section: 4
- 41. Answer: c Difficulty: 3 Section: 5
- 42. Answer: b Difficulty: 3 Section: 5
- 43. Answer: a Difficulty: 2 Section: 5
- 44. Answer: a Difficulty: 3 Section: 5
- 45. Answer: a Difficulty: 3 Section: 3

## Chapter 4: Bipolar Junction Transistors (BJTs)

### MULTIPLE CHOICE

- BJT transistors have two PN junctions.
  - true
  - false
- A BJT transistor has the base-emitter junction reverse biased for proper operation.
  - true
  - false
- The ratio  $I_E/I_C$  is  $\beta_{dc}$ .
  - true
  - false
- Proper operation of a BJT requires that the base-collector junction should be reverse biased.
  - true
  - false
- The formula for  $I_C$  is,  $I_C = I_E - I_B$ .
  - true
  - false
- A BJT has an  $I_B$  of  $75 \mu\text{A}$  and a  $\beta_{dc}$  of 100. The value of  $I_C$  is:
  - $175 \mu\text{A}$
  - $75 \text{ mA}$
  - $10 \text{ mA}$
  - $7.5 \text{ mA}$
- A certain transistor has an  $I_C = 12 \text{ mA}$  and an  $I_B = 125 \mu\text{A}$ .  $\beta_{dc}$  is:
  - 150
  - 15
  - 96
  - 12
- Normal operation of an NPN BJT requires the base to be \_\_\_\_\_ with respect to the emitter, and \_\_\_\_\_ with respect to the collector.
  - positive, negative
  - positive, positive
  - negative, positive
  - negative, negative
- A transistor amplifier has an input voltage of  $67 \text{ mV}$  and an output voltage of  $2.48 \text{ V}$ . The voltage gain is:
  - 67
  - 37
  - 27
  - 17

**Chapter 4: Bipolar Junction Transistors (BJTs)**

10. A 22 mV signal is applied to the base of a properly biased transistor that has an  $r_e = 7 \Omega$  and an  $R_C = 12 \text{ k}\Omega$ . The output voltage at the collector is:
- 22 mV
  - 17.1 V
  - 7 V
  - 3.77 V

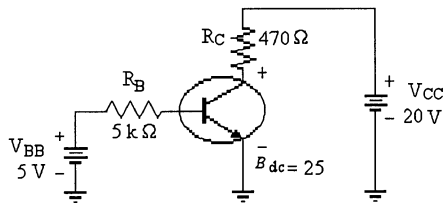

Figure 4-1

11. Refer to Figure 4-1. This circuit is operating:
- in cutoff
  - in saturation
  - normally
  - incorrectly because the bias voltages are wrong
12. Refer to Figure 4-1. The value of  $I_B$  is:
- 8.6 mA
  - 860  $\mu\text{A}$
  - 1 mA
  - 0.7  $\mu\text{A}$
13. Refer to Figure 4-1. If the value of  $V_{BB}$  were increased to 10 V, the transistor would be:
- cut off
  - saturated
  - operating ok
  - cannot be determined
14. Refer to Figure 4-1. If this transistor is operating in saturation, minimum value of  $I_{C(sat)}$  flowing is:
- 9.4 mA
  - 4.26 mA
  - 28.6 mA
  - 42.6 mA
15. Refer to Figure 4-1. Assume that this circuit is operating in cutoff. The measurement, if any, that would confirm this assumption is:
- $V_{BE} = 0.7 \text{ V}$
  - $V_{CE} = 8 \text{ V}$
  - $V_{CE} = 20 \text{ V}$
  - $V_{CC} = 20 \text{ V}$
  - none of these



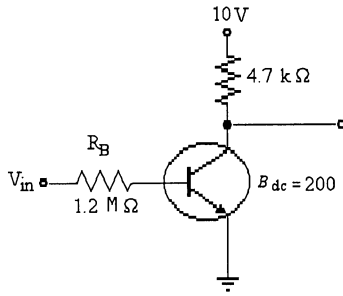

Figure 4-2

16. Refer to Figure 4-2. The value of  $I_C$  at cutoff is:
- 0 mA
  - 2.13 mA
  - 10.65  $\mu$ A
  - 10 mA
17. Refer to Figure 4-2. If the value of the collector resistor is increased to 6.8 k $\Omega$ , the new value of  $I_{C(sat)}$  is:
- 2.13 mA
  - .68 mA
  - 1.47 mA
  - 0 mA

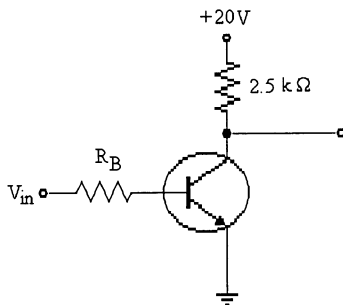

Figure 4-3

18. Refer to Figure 4-3. If the collector resistor value is changed to 4.7 k $\Omega$  and  $\beta_{dc} = 200$ ,  $I_{C(sat)}$  would be:
- 4.26 mA
  - 8 mA
  - 4.26  $\mu$ A
  - 8.426 mA
19. Refer to Figure 4-3. If the measure voltage from the collector to ground was 0 V, the transistor is operating in:
- saturation
  - cutoff
  - normal
  - not enough data

**Chapter 4: Bipolar Junction Transistors (BJTs)**

20. Refer to Figure 4-3. This circuit is saturated. To get the circuit to operate close to its linear range:
- $R_B$  should be decreased
  - $R_C$  should be decreased
  - $V_{in}$  should be increased
  - $R_B$  should be increased
21. A 35 mV signal is applied to the base of a properly biased transistor with an  $r_e = 8 \Omega$  and  $R_C = 1 \text{ k}\Omega$ . The output signal voltage at the collector is:
- 3.5 V
  - 28.57 V
  - 4.375 V
  - 4.375 mV

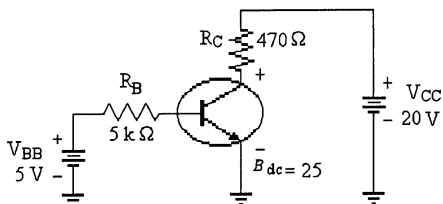

Figure 4-1

22. Refer to Figure 4-1. The value of  $V_{CE}$  is:
- 9.9 V
  - 9.2 V
  - 0.7 V
  - 19.3 V

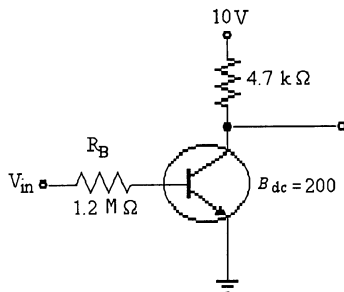

Figure 4-2

23. Refer to Figure 4-2. The minimum value of  $I_B$  that will produce saturation is:
- 0.25 mA
  - 5.325  $\mu\text{A}$
  - 1.065  $\mu\text{A}$
  - 10.65  $\mu\text{A}$

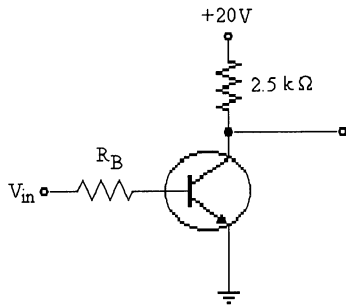

Figure 4-3

24. Refer to Figure 4-3. The voltage  $V_{CE}$  was measured and found to be 20 V. The transistor is operating in:
- saturation
  - cutoff
  - normal
  - not enough data
25. Refer to Figure 4-3. If  $V_{CE}$  is measured and is equal to nearly zero, the transistor is operating in:
- cutoff
  - normally
  - saturation
  - cannot be determined
26. In an NPN transistor, the majority carriers in the base are:
- free electrons
  - holes
  - neither
  - both
27. The base of an NPN transistor is thin and:
- heavily doped
  - lightly doped
  - metallic
  - doped by a pentavalent material
28. In a transistor, the relation of the three transistor currents is:
- $I_C = I_E + I_B$
  - $I_C = I_B - 2I_E$
  - $I_E = I_C + I_B$
  - $I_C = I_E + I_B$
29. A transistor has a  $\beta_{DC}$  of 250 and a base current,  $I_B$ , of 20  $\mu\text{A}$ . The collector current,  $I_C$ , equals:
- 500  $\mu\text{A}$
  - 5 mA
  - 50 mA
  - 5 A

**Chapter 4: Bipolar Junction Transistors (BJTs)**

30. In a transistor, collector current is controlled by:
- a) collector voltage
  - b) base current
  - c) collector resistance
  - d) all of the above
31. Most of the electrons in the base of an NPN transistor flow:
- a) out of the base lead
  - b) into the collector
  - c) into the emitter
  - d) into the base supply
32. When a transistor is operated in the active region, changes in the collector voltage  $V_{CC}$ :
- a) produce changes in collector current
  - b) produce changes in base voltage
  - c) have little or no effect on collector current
  - d) produce changes in emitter voltage
33. A bipolar junction transistor has \_\_\_\_ regions of operation.
- a) 1
  - b) 2
  - c) 3
  - d) 4
34. Which region in a transistor has to dissipate the most heat?
- a) Emitter
  - b) Base
  - c) Collector
  - d) Anode
35. The symbol  $h_{FE}$  is the same as:
- a)  $\beta_{DC}$
  - b)  $\alpha_{DC}$
  - c)  $h_{j-fj}$
  - d)  $\beta_{ac}$
36.  $V_{CE}$  approximately equals \_\_\_\_\_ when a transistor switch is in saturation.
- a)  $V_C$
  - b)  $V_B$
  - c) 0.2 V
  - d) 0.7 V
37. When a transistor switch is on, the collector current is limited by \_\_\_\_\_.
- a) the base current
  - b) the load resistance
  - c) the base voltage
  - d) the base resistance

38. The signal output voltage ( $V_{out}$ ) is a function of the \_\_\_\_\_.
- current flowing base to collector
  - voltage drop emitter to base
  - power being dissipated in the collector
  - changing collector current ( $I_C$ ) flowing through the collector resistor  $R_C$
39. The signal voltage gain of an amplifier,  $A_V$ , is defined as:
- $A_V = \frac{V_{in}}{V_{out}}$
  - $A_V = I_C \times R_C$
  - $A_V = \frac{R_C}{r'_e}$
  - $A_V = \frac{R_C}{R_L}$
40. When transistors are used in digital circuits they usually operate in the:
- active region
  - breakdown region
  - saturation and cutoff regions
  - linear region
41. When trouble-shooting a Bipolar Junction Transistor using an ohmmeter, and one of the junctions reads low in both directions, the junction is shorted and the transistor is bad. If one of the junctions reads high in both directions, the junction is shorted and the transistor is good?
- true
  - false
42. The transistor provides the control function of opening or closing a \_\_\_\_\_.
- voltage path
  - current path
  - power path
  - ground path
43. When a transistor switch is on, the collector current is limited by \_\_\_\_\_.
- the base current
  - the load resistance
  - the base voltage
  - the base resistance
44. A transistor output characteristic curve is a graph showing:
- emitter current ( $I_E$ ) versus collector/emitter voltage ( $V_{CE}$ ) with ( $I_B$ ) base current held constant.
  - collector current ( $I_C$ ) versus collector/emitter voltage ( $V_{CE}$ ) with ( $I_B$ ) base current held constant.
  - collector current ( $I_C$ ) versus collector/emitter voltage ( $V_C$ ) with ( $I_B$ ) base current held constant.
  - collector current ( $I_C$ ) versus collector/emitter voltage ( $V_{CC}$ ) with ( $I_B$ ) base current held constant.

**Chapter 4: Bipolar Junction Transistors (BJTs)**

1. Answer: a Difficulty: 2
2. Answer: b Difficulty: 2
3. Answer: b Difficulty: 2
4. Answer: a Difficulty: 2
5. Answer: a Difficulty: 2
6. Answer: d Difficulty: 2
7. Answer: c Difficulty: 2
8. Answer: a Difficulty: 2
9. Answer: b Difficulty: 2
10. Answer: d Difficulty: 2
11. Answer: c Difficulty: 3
12. Answer: b Difficulty: 2
13. Answer: b Difficulty: 3
14. Answer: d Difficulty: 3
15. Answer: c Difficulty: 3
16. Answer: a Difficulty: 2
17. Answer: c Difficulty: 2
18. Answer: a Difficulty: 2
19. Answer: a Difficulty: 2
20. Answer: d Difficulty: 3
21. Answer: c Difficulty: 2
22. Answer: a Difficulty: 2
23. Answer: d Difficulty: 2
24. Answer: b Difficulty: 2
25. Answer: c Difficulty: 3

- 26. Answer: b Difficulty: 1 Section: 1
- 27. Answer: b Difficulty: 2 Section: 2
- 28. Answer: c Difficulty: 2 Section: 2
- 29. Answer: b Difficulty: 2 Section: 3
- 30. Answer: b Difficulty: 2 Section: 3
- 31. Answer: b Difficulty: 2 Section: 3
- 32. Answer: c Difficulty: 3 Section: 3
- 33. Answer: b Difficulty: 2 Section: 3
- 34. Answer: c Difficulty: 2 Section: 3
- 35. Answer: a Difficulty: 2 Section: 3
- 36. Answer: c Difficulty: 2 Section: 3
- 37. Answer: b Difficulty: 2 Section: 3
- 38. Answer: d Difficulty: 3 Section: 4
- 39. Answer: c Difficulty: 2 Section: 4
- 40. Answer: c Difficulty: 1 Section: 5
- 41. Answer: b Difficulty: 3 Section: 7
- 42. Answer: b Difficulty: 2 Section: 3
- 43. Answer: b Difficulty: 2 Section: 5
- 44. Answer: b Difficulty: 3 Section: 3

## Chapter 5: Transistor Bias Circuits

### MULTIPLE CHOICE

1. Biasing a BJT amplifier means setting the dc voltages with the correct bias for proper operation.
  - a) true
  - b) false
2. A transistor operating in saturation has very little current flowing.
  - a) true
  - b) false
3. The base of fixed-bias circuit arrangement provides good stability because the Q-point does not vary with temperature.
  - a) true
  - b) false
4. Negative feedback in the collector-feedback circuit provides a more stable operation.
  - a) true
  - b) false
5. The correct formula for finding the dc current gain is  $\beta_{dc} = I_C/I_B$ .
  - a) true
  - b) false
6. A certain transistor in a fixed-bias circuit has these values,  $I_B = 50 \mu\text{A}$ ,  $\beta_{dc} = 125$ ,  $V_{CC} = 18 \text{ V}$ , and  $R_C = 1.2 \text{ k}\Omega$ .  $V_C$  is:
  - a) 0 V
  - b) 7.5 V
  - c) 10.5 V
  - d) 18 V
7. An indication of cutoff is that:
  - a)  $I_C = I_{C(sat)}$
  - b)  $V_{CE} = 0 \text{ V}$
  - c)  $V_{BE} = 0.7 \text{ V}$
  - d)  $V_{CE} = V_{CC}$

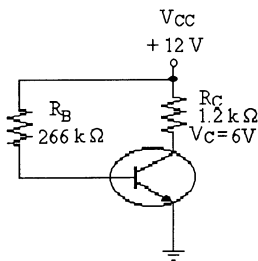

Figure 5-1

8. Refer to Figure 5-1. This transistor is biased for \_\_\_\_\_ operation.
  - a) saturation
  - b) linear
  - c) cutoff
  - d) a or c



9. Refer to Figure 5-1. The voltage on the base of this silicon transistor is:  
 a) 0.3 V  
 b) 0 V  
 c) 12 V  
 d) 11.3 V  
 e) 0.7 V
10. Refer to Figure 5-1. If  $\beta_{dc} = 100$ , the minimum value of  $I_B$  that would cause this transistor to saturate is:  
 a) 100  $\mu\text{A}$   
 b) 50  $\mu\text{A}$   
 c) 1 mA  
 d) 0.1 mA
11. Refer to Figure 5-1. If  $V_C$  is increased to 9 V, the change that is correct to do is to:  
 a) increase the value of  $R_B$   
 b) replace the transistor with one with a higher  $\beta_{dc}$   
 c) decrease the value of  $R_B$   
 d) increase the value of  $R_C$

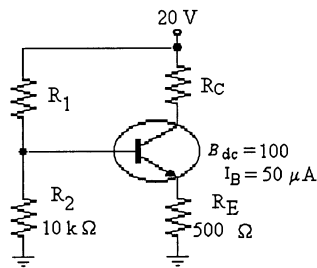

Figure 5-2

12. Refer to Figure 5-2. The value of  $R_C$  that will produce a value of  $V_C = 10\text{ V}$  is:  
 a) 2.2  $\text{k}\Omega$   
 b) 2  $\text{k}\Omega$   
 c) 1  $\text{k}\Omega$   
 d) 500  $\Omega$
13. Refer to Figure 5-2. If the transistor were replaced with a transistor whose  $\beta_{dc} = 200$ , the change that might occur is:  
 a)  $V_C$  would increase to near 20 V  
 b)  $V_C$  would decrease to near 0 V  
 c)  $I_B$  would increase significantly  
 d)  $V_C$  would change a small amount
14. Refer to Figure 5-2. If  $V_C = 10\text{ V}$ , the minimum value of  $I_B$  that would cause saturation is:  
 a) 10 mA  
 b) 8 mA  
 c) 80  $\mu\text{A}$   
 d) 100  $\mu\text{A}$

## Chapter 5: Transistor Bias Circuits

15. Refer to Figure 5-2. The purpose for  $R_1$  and  $R_2$  is:
  - a) to form an upper limit for the base voltage
  - b) to stabilize the operating point with negative feedback
  - c) to develop the output voltage
  - d) to maintain  $V_{BE}$  at 0.7 V
16. Refer to Figure 5-2. The purpose of  $R_C$  is:
  - a) to form an upper limit for the base voltage
  - b) to stabilize the operating point with negative feedback
  - c) to develop the output voltage
  - d) to maintain  $V_{BE}$  at 0.7 V
17. Refer to Figure 5-2. The purpose of  $R_E$  is:
  - a) to form an upper limit for the base voltage
  - b) to stabilize the operating point with negative feedback
  - c) to develop the output voltage
  - d) to maintain  $V_{BE}$  at 0.7 V
18. Two important easily measured values that determine if a transistor amplifier is operating correctly are:
  - a)  $\beta_{dc}$  and  $I_B$
  - b)  $I_C$  and  $V_C$
  - c)  $V_C$  and  $V_{BE}$
  - d)  $V_{BE}$  and  $I_E$
19. Saturation and cutoff are operating conditions that are very useful when operating the transistor:
  - a) as a linear amplifier
  - b) as a switch
  - c) as a current amplifier
  - d) none of the above
20. For linear operation, it is usual to set the Q-point so that:
  - a)  $V_{CE} \approx V_{CC}$
  - b)  $V_{CE} \approx V_E$
  - c)  $V_{CE} \approx V_{CC}/4$
  - d)  $V_{CE} \approx V_{CC}/2$

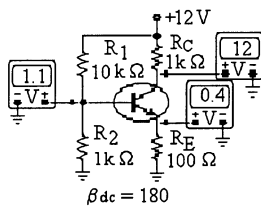

Figure 5-3 (a)

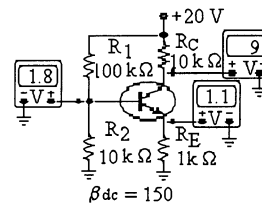

Figure 5-3 (b)

21. Refer to Figure 5-3 (a). The most probable cause of trouble, if any, from these voltage measurements would be:
  - a) the base-emitter junction is open
  - b)  $R_E$  is open
  - c) a short from collector to emitter
  - d) no problems

22. Refer to Figure 5-3 (b). The most probable cause of trouble, if any, from these voltage measurements is:
- the base-emitter junction is open
  - $R_E$  is open
  - a short from collector to emitter
  - no problems

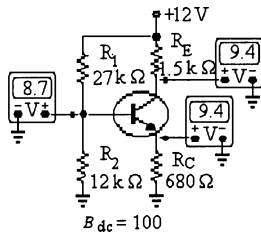

Figure 5-3 (c)

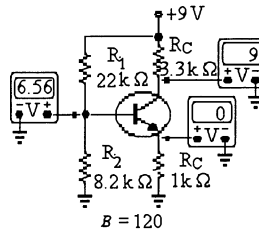

Figure 5-3 (d)

23. Refer to Figure 5-3 (c). The most probable cause of trouble, if any, from these voltage measurements is:
- the base-emitter junction is open
  - $R_E$  is open
  - a short from collector to emitter
  - no problems
24. Refer to Figure 5-3 (d). The most probable cause of trouble, if any, from these voltage measurements is:
- the base-emitter junction is open
  - $R_E$  is open
  - a short from collector to emitter
  - no problems
25. The most suitable biasing technique used is the:
- base-bias
  - emitter-bias
  - voltage-divider bias
  - collector-bias
26. Improper biasing can cause distortion in transistor circuits:
- input signal
  - output signal
  - input/output signal
  - frequency response
27. On a dc load line, the area between saturation and cutoff is called the:
- saturation zone
  - depletion region
  - linear region
  - breakdown region

## Chapter 5: Transistor Bias Circuits

28. Three different Q points are shown on a dc load line. The upper Q point represents the:
- minimum current gain
  - intermediate current gain
  - maximum current gain
  - cutoff point
29. If a transistor operates at the middle of the dc load line, a decrease in the current gain will move the Q point:
- off the load line
  - nowhere
  - up
  - down
30. The input resistance,  $R_{in}$ , of a voltage-divider biased NPN transistor is \_\_\_\_\_ by a factor of  $\beta$ .
- stepped-up
  - stepped-down
  - not affected
  - none of the above
31. Voltage-divider bias provides:
- an unstable Q point
  - a stable Q point
  - A Q point that easily varies with changes in the transistor's current gain
  - both a and c above
32. For transistors using voltage-divider bias, the base current should be:
- much larger than the current through the voltage divider
  - about one-half the collector current
  - much smaller than the current through the voltage divider
  - $\beta$  times larger than the collector current
33. With voltage-divider bias, the base voltage is:
- less than the base supply voltage
  - equal to the base supply voltage
  - greater than the base supply voltage
  - greater than the collector supply voltage
34. Base bias provides:
- a very stable Q point
  - a very unstable Q point
  - no current gain
  - zero current in the base and collector circuits
35. A circuit with a fixed emitter current is called:
- base-bias
  - emitter-bias
  - transistor-bias
  - two-supply bias

36. For emitter bias, changes in current gain:
- do not affect the Q point
  - severely affect the Q point
  - do not occur in the transistor
  - affect the collector voltage
37. For collector feedback bias, the Q point is set near the center of the load line by making:
- $R_B = \beta_{DC}R_C$
  - $R_B = 2\beta_{DC}R_C$
  - $R_B = \frac{R_C}{\beta_{DC}}$
  - $R_C = \beta_{DC}R_B$
38. The Q-point of a Two Supply Emitter-Bias circuit is not affected by:
- $V_{CC}$
  - collector resistance
  - emitter resistance
  - current gain
39. When measuring the resistance between the collector and emitter with an ohmmeter, the reading should be:
- low in both directions
  - high in both directions
  - high in one direction and low in the other
  - zero both ways
40. The emitter resistor in a voltage-divider bias circuit is shorted. The collector voltage will equal approximately:
- $V_{CC}$
  - 0 V
  - one-half  $V_{CC}$
  - none of the above
41. If the base-emitter junction opens in a voltage-divider bias circuit, the emitter voltage will measure:
- 0 V
  - 0.7 V less than the base
  - 0.7 V more than the base
  - a voltage nearly equal to  $V_{CC}$
42. If the collector resistor decreases to zero in a base-biased circuit, the load line will become:
- horizontal
  - vertical
  - useless
  - flat
43. The first step in analyzing emitter-based circuits is to find the:
- base current
  - emitter voltage
  - emitter current
  - collector current

**Chapter 5: Transistor Bias Circuits**

44. If the current gain is unknown in an emitter-biased circuit, you cannot calculate the:
- a) emitter voltage
  - b) emitter current
  - c) collector current
  - d) base current
45. If the emitter resistor is open, the collector voltage is:
- a) low
  - b) high
  - c) unchanged
  - d) unknown

1. Answer: a Difficulty: 2
2. Answer: b Difficulty: 2
3. Answer: b Difficulty: 2
4. Answer: a Difficulty: 2
5. Answer: a Difficulty: 2
6. Answer: c Difficulty: 2
7. Answer: d Difficulty: 2
8. Answer: b Difficulty: 2
9. Answer: e Difficulty: 2
10. Answer: a Difficulty: 2
11. Answer: a Difficulty: 3
12. Answer: b Difficulty: 3
13. Answer: d Difficulty: 3
14. Answer: c Difficulty: 3
15. Answer: a Difficulty: 3
16. Answer: c Difficulty: 2
17. Answer: b Difficulty: 2
18. Answer: c Difficulty: 2
19. Answer: b Difficulty: 2
20. Answer: d Difficulty: 2
21. Answer: b Difficulty: 3
22. Answer: d Difficulty: 3
23. Answer: c Difficulty: 3
24. Answer: a Difficulty: 3
25. Answer: c Difficulty: 2

**Chapter 5: Transistor Bias Circuits**

- 26. Answer: b Difficulty: 2 Section: 1
- 27. Answer: c Difficulty: 3 Section: 1
- 28. Answer: c Difficulty: 2 Section: 1
- 29. Answer: d Difficulty: 2 Section: 1
- 30. Answer: a Difficulty: 3 Section: 3
- 31. Answer: b Difficulty: 1 Section: 2
- 32. Answer: c Difficulty: 3 Section: 2
- 33. Answer: a Difficulty: 1 Section: 2
- 34. Answer: b Difficulty: 2 Section: 3
- 35. Answer: b Difficulty: 2 Section: 3
- 36. Answer: a Difficulty: 3 Section: 3
- 37. Answer: a Difficulty: 4 Section: 3
- 38. Answer: d Difficulty: 3 Section: 3
- 39. Answer: b Difficulty: 2 Section: 4
- 40. Answer: a Difficulty: 2 Section: 4
- 41. Answer: a Difficulty: 2 Section: 4
- 42. Answer: b Difficulty: 3 Section: 4
- 43. Answer: b Difficulty: 2 Section: 3
- 44. Answer: d Difficulty: 2 Section: 4
- 45. Answer: b Difficulty: 2 Section: 4



## Chapter 6: BJT Amplifiers

### MULTIPLE CHOICE

1. A common-emitter amplifier has very high input impedance, high voltage gain, and high current gain.  
a) true  
b) false
2. A high input impedance amplifier could be a Darlington pair.  
a) true  
b) false
3. A common-collector amplifier is also known as an emitter follower.  
a) true  
b) false
4. The total voltage gain, expressed as a ratio, of a multistage amplifier is the sum of the individual voltage gains.  
a) true  
b) false
5. A common-base amplifier has a high current gain.  
a) true  
b) false
6. A certain transistor has a dc emitter current of 25 mA. The value of  $r_e$  is:  
a) 25  $\Omega$ .  
b) 2.5  $\Omega$ .  
c) 1.2  $\Omega$ .  
d) 1  $\Omega$ .

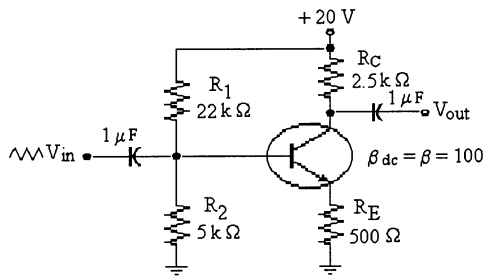

Figure 6-1

7. Refer to Figure 6-1. The value of  $V_C$  is:  
a) 20 V  
b) 10 V  
c) 5 V  
d) 0 V

## Chapter 6: BJT Amplifiers

8. Refer to Figure 6-1. If an emitter-bypass capacitor was added, the voltage gain:
  - a) would not change
  - b) would decrease
  - c) would increase
  - d) would decrease to zero
9. Refer to Figure 6-1. If  $R_2$  opened,  $V_{CE}$  would be:
  - a) 0 V
  - b) 20 V
  - c) 10 V
  - d) 4.8 V
10. Refer to Figure 6-1. If  $R_2$  opened, the value of  $I_C$  would be:
  - a) 6 mA
  - b) 6.67 mA
  - c) 8 mA
  - d) 10 mA
11. Refer to Figure 6-1. If  $R_C$  opened,  $V_E$  would:
  - a) increase
  - b) decrease
  - c) remain the same
  - d) be undetermined
12. Refer to Figure 6-1. If the emitter collector shorted, the voltage  $V_C$  would be:
  - a) 0 V
  - b) 20 V
  - c) 16.67 V
  - d) 3.33 V
13. Refer to Figure 6-1. If the collector opened internally, the voltage on the collector would:
  - a) increase
  - b) decrease
  - c) remain the same
  - d) be undetermined
14. Refer to Figure 6-1. If  $V_E = 0$ , the trouble might be that:
  - a)  $R_E$  is open
  - b)  $R_C$  is open
  - c)  $R_2$  is open
  - d)  $R_1$  is open
15. Refer to Figure 6-1. If an emitter-bypass capacitor was installed, the value of  $R_{in}$  would be:
  - a) 50  $\Omega$
  - b) 175  $\Omega$
  - c) 378  $\Omega$
  - d) 500  $\Omega$

16. Refer to Figure 6-1. If an emitter-bypass capacitor was installed, the new  $A_V$  would be:
- 4.96
  - 125
  - 398
  - 600

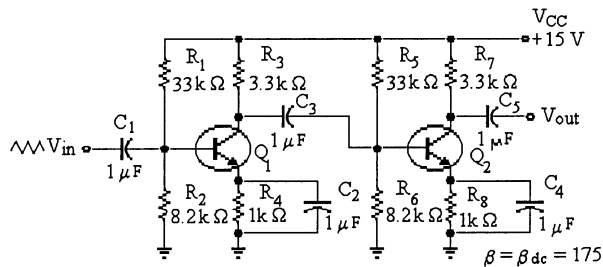

Figure 6-2

17. Refer to Figure 6-2. If  $A_{V1} = 75$  and  $A_{V2} = 95$ ,  $A_{VT}$  would be:
- 75
  - 95
  - 1275
  - 7125
18. Refer to Figure 6-2. When checking this amplifier,  $V_{out}$  was below normal. The trouble might be:
- an open  $C_3$
  - an open  $C_4$
  - $C_4$  is shorted
  - $C_1$  is open
19. Refer to Figure 6-2. If  $V_{B2}$  was higher than normal. The problem, if any, could be:
- $C_3$  is shorted
  - $R_3$  is open
  - $BE_1$  is open
  - $C_2$  is open
20. Refer to Figure 6-2. In servicing this amplifier  $V_{out}$  was found less than normal. The problem could be caused by:
- an open  $C_3$
  - an open  $C_2$
  - an open base-emitter of  $Q_2$
  - a shorted  $C_2$
21. Refer to Figure 6-2. The output signal from the first stage of this amplifier is 0 V. The trouble could be caused by:
- an open  $C_4$
  - an open  $C_2$
  - an open base-emitter of  $Q_2$
  - a shorted  $C_4$

## Chapter 6: BJT Amplifiers

22. The best selection for a high input impedance amplifier is a:
- low gain common-emitter
  - common-base
  - common-collector
  - high gain common-emitter
23. The characteristic that is not of a common-base amplifier is:
- high input impedance
  - current gain of 1
  - medium voltage gain
  - high output impedance
24. The characteristic that is not of an emitter-follower is:
- voltage gain of 1
  - low input impedance
  - low output impedance
  - medium current gain
25. The best choice for a very high power amplifier is a(n):
- common-collector
  - common-base
  - common-emitter
  - emitter-follower
26. For transistors:
- the dc and ac current gains are the same
  - the dc current gain is zero
  - the dc and ac current gains are usually different
  - amplification of signal voltage is not possible
27. The ac resistance of the emitter diode  $r_e'$  equals:
- $\frac{25 \text{ mV}}{I_E}$
  - $25 \text{ mV} \times I_C$
  - $\frac{25 \text{ mV}}{I_C}$
  - $\frac{25 \text{ mV}}{I_B}$
28. In general, coupling capacitors can be considered:
- open for signal voltage and a short for dc
  - short for signal voltage and an open for dc
  - lossy
  - short for signal voltage and a short for dc
29. The primary reason an ac load line differs from a dc load line is:
- the effective ac collector resistance is greater than the dc collector resistance
  - the effective ac collector resistance is less than the dc collector resistance
  - changes in current are non-linear for small-signal amplifier operation
  - the ac load line is not as steep as the dc load line

30. The h-parameter,  $h_{fe}$ , is the same as \_\_\_\_\_ of the transistor.
- dc Beta
  - ac Beta
  - maximum collector current
  - minimum hold current
31. The capacitor that produces an ac ground is called a(n):
- bypass capacitor
  - coupling capacitor
  - dc open
  - ac open
32. Reducing all dc sources to zero is one of the steps in getting the:
- dc equivalent circuit
  - ac equivalent circuit
  - complete amplifier circuit
  - voltage-divider biased circuit
33. The input resistance,  $R_{in(base)}$ , of a common-emitter amplifier, consists of \_\_\_\_\_.
- $r_b \parallel \beta r_e$
  - $\beta_{ac} \beta r_e'$
  - $r_e \parallel \beta r_e'$
  - $R_G \parallel r_c \parallel \beta r_e'$
34. The three factors that must be taken into account when determining the actual signal voltage at the base of a small signal bipolar amplifier are:
- source resistance, emitter resistance, and input resistance
  - source resistance, bias resistance, and input resistance
  - source resistance, collector resistance, internal resistance
  - source resistance, bias resistance, and load resistance
35. The value of output resistance in a common-emitter amplifier,  $R_{out}$ , consists of:
- $R_C$
  - $R_L + R_C$
  - $\beta \parallel R_C$
  - $R_L \parallel R_C$
36. The voltage gain of an amplifier is defined as:
- the ac input voltage divided by the ac output voltage
  - the ac collector current divided by the ac base current
  - the ac output collector voltage divided by the ac input base voltage
  - the ac collector current divided by the ac emitter current

**Chapter 6: BJT Amplifiers**

37. Removing a bypass capacitor from a fully bypassed, common-emitter amplifier circuit will \_\_\_\_\_ voltage gain and \_\_\_\_\_ input resistance.
- a) increase, decrease
  - b) decrease, increase
  - c) decrease, decrease
  - d) increase, increase
38. The voltage gain of a common-emitter amplifier,  $A_V$ , is defined as:
- a)  $A_V = \frac{V_b}{V_c}$
  - b)  $A_V = I_C \times R_C$
  - c)  $A_V = \frac{I_e R_C}{I_e r'_e}$
  - d)  $A_V = \frac{R_C}{r_e}$
39. For a bypass capacitor to work properly, the:
- a)  $X_C$  should be ten times smaller than  $R_E$  at the minimum operating frequency
  - b)  $X_C$  should equal  $R_E$
  - c)  $X_C$  should be ten times greater than  $R_E$  at the minimum operating frequency
  - d)  $X_C$  should be twice the value of the  $R_E$
40. A bypass capacitor is placed across the emitter resistor in a voltage-divider biased common-emitter amplifier circuit. This will:
- a) place the emitter at ac ground
  - b) shift the Q point on the dc load line
  - c) reduce the emitter's dc voltage to zero
  - d) all of the above
41. Removing the emitter bypass capacitor from a common-emitter amplifier:
- a) increases  $R_{in}$  and decreases  $A_V$ , voltage gain
  - b) decreases  $R_{in}$  and increases  $A_V$ , voltage gain
  - c) does not affect  $R_{in}$
  - d) increases the distortion
42. Increasing the resistance of the load resistor  $R_L$ , in an RC coupled common-emitter amplifier will have what effect on voltage gain?
- a) does not affect the voltage gain
  - b) decreases the voltage gain
  - c) increases the voltage gain
  - d) none of the above
43. Leaving some of the emitter resistance unbypassed in a common-emitter amplifier will:
- a) reduce distortion
  - b) stabilize the voltage gain
  - c) increase the input impedance
  - d) all of the above

44. In a swamped amplifier, the effects of the emitter diode ( $r'_e$ ) become:
- a) important to voltage gain
  - b) critical to input impedance
  - c) significant to the analysis
  - d) unimportant
45. To reduce the distortion of an amplified signal, you can increase the:
- a) collector resistance
  - b) emitter feedback resistance
  - c) generator resistance
  - d) load resistance
46. An emitter follower has a voltage gain that is:
- a) much less than one
  - b) approximately equal to one
  - c) greater than one
  - d) zero
47. The total ac emitter resistance of an emitter follower equals:
- a)  $r'_e$
  - b)  $r_e$
  - c)  $R_e + r'_e$
  - d)  $R_E$
48. The input resistance of the base of an emitter follower is usually:
- a) low
  - b) high
  - c) shorted to ground
  - d) open
49. Often a common-collector will be the last stage before the load; the main function(s) of this stage is to:
- a) provide voltage gain
  - b) buffer the voltage amplifiers from the low resistance load and provide impedance matching for maximum power transfer
  - c) provide phase inversion
  - d) provide a high frequency path to improve the frequency response
50. Output resistance in a common-collector amplifier circuit is stepped down by a factor of:
- a) alpha  $\alpha$
  - b) Beta  $\beta$
  - c)  $R_E \parallel R_L$
  - d)  $r'_e + r_e$

**Chapter 6: BJT Amplifiers**

51. If two transistors are connected as a Darlington pair and each transistor has a  $\beta$  of 175, what would the overall current gain of the pair equal:
- a) 30,625
  - b) 3,625
  - c) 10,000
  - d) 5,000
52. The characteristic of a common-base amplifier that is most useful is:
- a) power amplification
  - b) voltage amplification
  - c) low output resistance
  - d) phase inversion
53. In a two-stage amplifier, the input resistance of the second stage:
- a) does not affect the voltage gain of the first stage
  - b) affects the voltage gain of the first stage
  - c) is in parallel with the collector resistor,  $R_C$ , of the first stage
  - d) both b and c above
54. In a two-stage amplifier, the voltage gain of the first stage is 80 and the voltage gain of the second stage is 50. How much is the overall voltage gain?
- a) 72
  - b) 130
  - c) 4,000
  - d) 400
55. If a CE stage is direct coupled to an emitter-follower, how many coupling capacitors are there between the two stages?
- a) 0
  - b) 1
  - c) 2
  - d) 3



1. Answer: b Difficulty: 2
2. Answer: a Difficulty: 2
3. Answer: a Difficulty: 2
4. Answer: b Difficulty: 2
5. Answer: b Difficulty: 2
6. Answer: d Difficulty: 2
7. Answer: c Difficulty: 2
8. Answer: c Difficulty: 2
9. Answer: a Difficulty: 3
10. Answer: b Difficulty: 3
11. Answer: b Difficulty: 2
12. Answer: d Difficulty: 2
13. Answer: a Difficulty: 3
14. Answer: d Difficulty: 2
15. Answer: c Difficulty: 2
16. Answer: d Difficulty: 2
17. Answer: d Difficulty: 2
18. Answer: b Difficulty: 3
19. Answer: a Difficulty: 3
20. Answer: b Difficulty: 2
21. Answer: c Difficulty: 3
22. Answer: c Difficulty: 2
23. Answer: a Difficulty: 2
24. Answer: b Difficulty: 2
25. Answer: c Difficulty: 2

**Chapter 6: BJT Amplifiers**

- 26. Answer: c Difficulty: 1 Section: 1
- 27. Answer: a Difficulty: 2 Section: 2
- 28. Answer: a Difficulty: 2 Section: 1
- 29. Answer: a Difficulty: 3 Section: 1
- 30. Answer: b Difficulty: 2 Section: 2
- 31. Answer: a Difficulty: 2 Section: 3
- 32. Answer: b Difficulty: 2 Section: 3
- 33. Answer: b Difficulty: 3 Section: 3
- 34. Answer: b Difficulty: 3 Section: 3
- 35. Answer: a Difficulty: 2 Section: 3
- 36. Answer: c Difficulty: 2 Section: 3
- 37. Answer: b Difficulty: 3 Section: 3
- 38. Answer: c Difficulty: 3 Section: 3
- 39. Answer: a Difficulty: 2 Section: 3
- 40. Answer: a Difficulty: 2 Section: 3
- 41. Answer: a Difficulty: 3 Section: 3
- 42. Answer: c Difficulty: 3 Section: 3
- 43. Answer: d Difficulty: 2 Section: 3
- 44. Answer: d Difficulty: 2 Section: 3
- 45. Answer: b Difficulty: 3 Section: 3
- 46. Answer: b Difficulty: 1 Section: 4
- 47. Answer: c Difficulty: 2 Section: 4
- 48. Answer: b Difficulty: 2 Section: 4
- 49. Answer: b Difficulty: 2 Section: 4
- 50. Answer: b Difficulty: 3 Section: 4

- 51. Answer: b Difficulty: 1 Section: 4
- 52. Answer: c Difficulty: 2 Section: 5
- 53. Answer: d Difficulty: 2 Section: 6
- 54. Answer: d Difficulty: 1 Section: 6
- 55. Answer: a Difficulty: 2 Section: 6

## Chapter 7: Field-Effect Transistors (FETs)

### *MULTIPLE CHOICE*

1. An FET has three terminals, source, drain, and gate.
  - a) true
  - b) false
2. The JFET operates with a forward-biased gate-source PN junction.
  - a) true
  - b) false
3. An E-MOSFET can be used as a switch.
  - a) true
  - b) false
4. A D-MOSFET can operate with both positive and negative values of  $V_{GS}$ .
  - a) true
  - b) false
5. Special care is required in handling a MOSFET.
  - a) true
  - b) false
6. An N-channel JFET has a  $V_D = 8\text{ V}$ ,  $V_{GS} = -5\text{ V}$ . The value of  $V_{DS}$  is:
  - a) 3 V
  - b) 8 V
  - c) -5 V
  - d) -3 V
7. Field effect transistors are also known as:
  - a) one-charge carrier
  - b) two-charge carrier
  - c) three-charge carrier
  - d) none of the above
8. The FET that has no physical channel is the:
  - a) D MOSFET
  - b) E MOSFET
  - c) JFET
  - d) none of the above
9. An FET that has no  $I_{DSS}$  parameter is the:
  - a) JFET
  - b) DE MOSFET
  - c) V MOSFET
  - d) E MOSFET

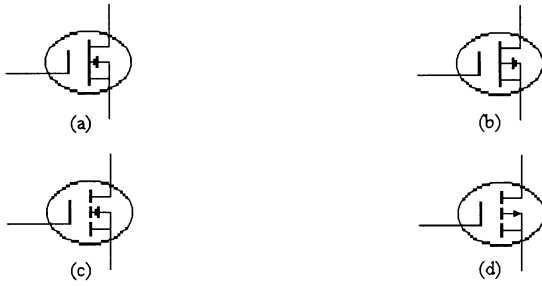

Figure 7-1

10. Refer to Figure 7-1 (a). This symbol identifies:
  - a) a P-channel E MOSFET
  - b) an N-channel D MOSFET
  - c) a P-channel D MOSFET
  - d) an N-channel E MOSFET
11. Refer to Figure 7-1 (b). This symbol identifies:
  - a) a P-channel E MOSFET
  - b) an N-channel D MOSFET
  - c) a P-channel D MOSFET
  - d) an N-channel E MOSFET
12. Refer to Figure 7-1 (c). This symbol identifies:
  - a) a P-channel E MOSFET
  - b) an N-channel D MOSFET
  - c) a P-channel D MOSFET
  - d) an N-channel E MOSFET
13. Refer to Figure 7-1 (d). This symbol identifies:
  - a) a P-channel E MOSFET
  - b) an N-channel D MOSFET
  - c) a P-channel D MOSFET
  - d) an N-channel E MOSFET

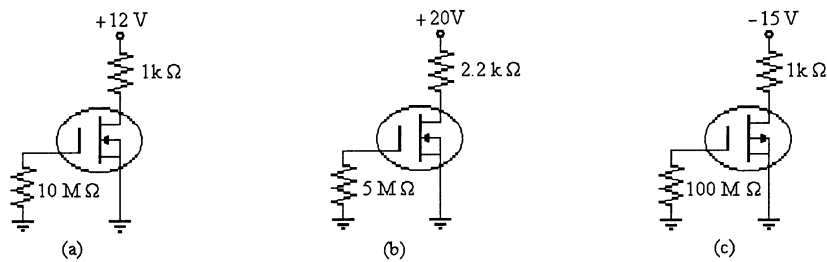

Figure 7-2

14. Refer to Figure 7-2 (a). If  $I_D = 4 \text{ mA}$ , the value of  $V_{DS}$  is:
  - a) 12 V
  - b) 8 V
  - c) 4 V
  - d) 0 V

**Chapter 7: Field-Effect Transistors (FETs)**

15. Refer to Figure 7-2 (b). If  $I_D = 4 \text{ mA}$ , the value of  $V_{GS}$  is:
  - a) 20 V
  - b) 11.2 V
  - c) 8.8 V
  - d) 0 V
  
16. Refer to Figure 7-2 (c). If  $I_D = 4 \text{ mA}$ , the value of  $V_{DS}$  is:
  - a) -11 V
  - b) -14 V
  - c) -15 V
  - d) 0 V
  
17. A JFET manufacturers data sheet specifies  $V_{GS(\text{off})} = -8 \text{ V}$  and  $I_{DSS} = 6 \text{ mA}$ . The value of  $I_D$  when  $V_{GS} = -4 \text{ V}$  would be:
  - a) 6 ma
  - b) 1.25 mA
  - c) 1.5 mA
  - d) 4 mA

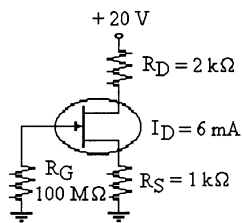

Figure 7-3

18. Refer to Figure 7-3. The value of the voltage drop across  $R_D$  is:
  - a) 20 V
  - b) 12 V
  - c) 6 V
  - d) 3 V
  
19. Refer to Figure 7-3. This amplifier is biased for:
  - a) linear operation
  - b) pinch-off operation
  - c) saturation
  - d) operation as a switch
  
20. Refer to Figure 7-3. In this circuit,  $V_{GS}$  is biased correctly for proper operation. This means that  $V_{GS}$  is:
  - a) positive
  - b) negative
  - c) either negative or positive
  - d) 0 V
  
21. Refer to Figure 7-3. Calculate the value of  $V_D$ .
  - a) 20 V
  - b) 8 V
  - c) 6 V
  - d) 2 V

22. Refer to Figure 7-3. Calculate the value of  $V_{DS}$ .
  - a) 0 V
  - b) 2 V
  - c) 4 V
  - d) -2 V
23. For proper operation, an N-channel E-MOSFET should be biased so that  $V_{GS}$  is:
  - a) either positive or negative
  - b) negative
  - c) positive
  - d) -4 V
24. A good application for a V-MOSFET would be:
  - a) as a power amplifier
  - b) as a low power amplifier
  - c) as a low input impedance device
  - d) as a substitute for a diode
25. A V MOSFET device operates in:
  - a) the depletion mode
  - b) the enhancement mode
  - c) a JFET mode
  - d) in either enhancement or depletion mode
26. The gate-source junction of a JFET is:
  - a) normally not biased
  - b) normally forward biased
  - c) normally reverse biased
  - d) a low resistance path for dc current when reverse biased
27. The channel width in a JFET is controlled by:
  - a) varying gate voltage
  - b) varying drain voltage
  - c) increasing forward bias on the gate-source junction
  - d) increasing reverse bias on the drain-source junction
28. When operated in the ohmic area, a JFET acts like a(n):
  - a) small resistor
  - b) voltage source
  - c) current source
  - d) insulator
29.  $V_{DS}$  equals pinchoff voltage divided by the:
  - a) drain current
  - b) gate current
  - c) ideal drain current
  - d) drain current for zero gate voltage
30.  $I_{D(ss)}$  can be defined as:
  - a) the minimum possible drain current
  - b) the maximum possible current with the drain shorted to the source
  - c) the maximum current drain-to-source with a shorted gate
  - d) the maximum drain current with the source shorted

**Chapter 7: Field-Effect Transistors (FETs)**

31. The pinchoff voltage has the same magnitude as the:
- a) gate voltage
  - b) drain-source voltage
  - c) gate-source voltage
  - d) gate-source cutoff voltage
32. JFETs are often called:
- a) one-way switches
  - b) two-way switches
  - c) bipolar devices
  - d) square-law devices
33. The transconductance curve of a JFET is a graph of:
- a)  $I_S$  versus  $V_{DS}$
  - b)  $I_C$  versus  $V_{CE}$
  - c)  $I_D$  versus  $V_{GS}$
  - d)  $I_D \times R_{DS}$
34. For a JFET, maximum drain current flows when:
- a)  $V_{GS}$  equals  $V_{GS(off)}$
  - b)  $V_{DS}$  is zero
  - c) the drain and source are interchanged
  - d)  $V_{GS}$  is zero
35. The transconductance curve of a JFET is:
- a) hyperbolic
  - b) linear
  - c) nonlinear
  - d) symmetrical
36. JFET data sheets specify input resistance by giving the values for  $V_{GS}$  and  $I_{DSS}$ .
- a) true
  - b) false
37. A \_\_\_\_\_ in  $V_{DS}$  will produce a \_\_\_\_\_ change in  $I_D$ .
- a) small, large
  - b) large, small
  - c) large, small
  - d) small, small
38. To get a negative gate-source voltage in a self-biased JFET circuit, you must use a:
- a) voltage divider
  - b) source resistor
  - c) ground
  - d) negative gate supply voltage
39. Under no signal conditions midpoint bias allows the maximum amount of drain current swing between  $I_{DSS}$  and zero.
- a) true
  - b) false



40. The easiest way to bias a JFET in the ohmic region is with:
- a) voltage-divider bias
  - b) self-bias
  - c) gate bias
  - d) source bias
41. One advantage of voltage-divider bias is that the dependency of drain current  $I_D$ , on the range of Q-Points is:
- a) increased
  - b) reduced
  - c) not affected
  - d) none of the above
42. The depletion-mode MOSFET can:
- a) operate with only positive gate voltages
  - b) operate with only negative gate voltages
  - c) not operate in the ohmic region
  - d) operate with positive as well as negative gate voltages
43. An N-channel E-MOSFET conducts when it has:
- a)  $V_{GS} > V_P$
  - b) a thin layer of positive charges in the substrate region near the  $\text{SiO}_2$  layer
  - c)  $V_{DS} > 0$
  - d) a thin layer of negative charges in the substrate region near the  $\text{SiO}_2$  layer
44. Power FET's, \_\_\_\_\_ devices that utilize a vertical internal construction, permit a wider channel and greater current capability.
- a) switching JFET
  - b) enhancement MOSFET
  - c) depletion MOSFET
  - d) linear FET
45. For an enhancement-mode MOSFET, the minimum  $V_{GS}$  required to produce drain current is called the:
- a) threshold voltage, designated  $V_{GS(th)}$
  - b) blocking voltage, designated  $V_B$
  - c) breakover voltage
  - d)  $I_{DSS}$
46. Special handling precautions should be taken when working with MOSFETs. Which of the following is **not one** of these precautions?
- a) All test equipment should be grounded.
  - b) MOSFET devices should have their leads shorted together for shipment and storage.
  - c) Never remove or insert MOSFET devices with the power on.
  - d) Workers handling MOSFET devices should not have grounding straps attached to their wrists.

**Chapter 7: Field-Effect Transistors (FETs)**

47. The simplest method to bias a D-MOSFET is to:
- a) set  $V_{GS} = +4$
  - b) set  $V_{GS} = -4$
  - c) set  $V_{GS} = 0$
  - d) select the correct value  $R_D$
48. The type of bias most often used with E-MOSFET circuits is:
- a) drain-feedback
  - b) constant current
  - c) voltage-divider
  - d) both a & c

1. Answer: a Difficulty: 2
2. Answer: b Difficulty: 2
3. Answer: a Difficulty: 2
4. Answer: a Difficulty: 2
5. Answer: a Difficulty: 2
6. Answer: a Difficulty: 2
7. Answer: a Difficulty: 2
8. Answer: b Difficulty: 2
9. Answer: d Difficulty: 2
10. Answer: b Difficulty: 2
11. Answer: c Difficulty: 2
12. Answer: d Difficulty: 2
13. Answer: a Difficulty: 2
14. Answer: b Difficulty: 2
15. Answer: d Difficulty: 2
16. Answer: a Difficulty: 3
17. Answer: c Difficulty: 3
18. Answer: b Difficulty: 2
19. Answer: a Difficulty: 2
20. Answer: b Difficulty: 3
21. Answer: b Difficulty: 2
22. Answer: b Difficulty: 2
23. Answer: c Difficulty: 2
24. Answer: a Difficulty: 2
25. Answer: b Difficulty: 2

**Chapter 7: Field-Effect Transistors (FETs)**

- 26. Answer: c Difficulty: 2 Section: 1
- 27. Answer: a Difficulty: 2 Section: 1
- 28. Answer: a Difficulty: 2 Section: 2
- 29. Answer: d Difficulty: 3 Section: 2
- 30. Answer: c Difficulty: 2 Section: 2
- 31. Answer: d Difficulty: 3 Section: 2
- 32. Answer: d Difficulty: 2 Section: 2
- 33. Answer: c Difficulty: 2 Section: 2
- 34. Answer: d Difficulty: 2 Section: 2
- 35. Answer: c Difficulty: 2 Section: 2
- 36. Answer: b Difficulty: 2 Section: 2
- 37. Answer: b Difficulty: 3 Section: 2
- 38. Answer: b Difficulty: 3 Section: 3
- 39. Answer: b Difficulty: 2 Section: 3
- 40. Answer: a Difficulty: 3 Section: 3
- 41. Answer: b Difficulty: 2 Section: 3
- 42. Answer: d Difficulty: 2 Section: 4
- 43. Answer: d Difficulty: 3 Section: 4
- 44. Answer: b Difficulty: 2 Section: 4
- 45. Answer: a Difficulty: 2 Section: 5
- 46. Answer: c Difficulty: 2 Section: 5
- 47. Answer: c Difficulty: 3 Section: 6
- 48. Answer: d Difficulty: 2 Section: 6

## Chapter 8: FET Amplifiers

### MULTIPLE CHOICE

1. The formula for the voltage gain of a common-source amplifier is  $R_D/g_m$ .
  - a) true
  - b) false
2. Load resistance added to the output of an amplifier increases the voltage gain.
  - a) true
  - b) false
3. The addition of a source bypass capacitor will increase the voltage gain.
  - a) true
  - b) false
4. In an amplifier using a JFET, the gate current is 0.
  - a) true
  - b) false
5. A common-source amplifier has a \_\_\_\_ phase shift between the input and the output.
  - a)  $45^\circ$
  - b)  $90^\circ$
  - c)  $180^\circ$
  - d)  $360^\circ$

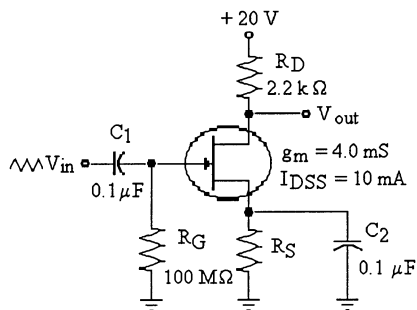

Figure 8-1

6. Refer to Figure 8-1. Assuming midpoint biasing, if  $V_{GS} = -4$  V, the value of  $R_S$  that will provide this value is:
  - a)  $600 \Omega$
  - b)  $1.2 \text{ k}\Omega$
  - c)  $80 \Omega$
  - d)  $800 \Omega$
7. Refer to Figure 8-1. If  $V_{in} = 50$  mV p-p, the output voltage is:
  - a) 50 mV p-p
  - b) 4.4 V p-p
  - c) 0.044 V p-p
  - d) 440 mV p-p

**Chapter 8: FET Amplifiers**

8. Refer to Figure 8-1. If the measured value of  $V_{out}$  was below normal, the problem might be one of the following:
- $R_D$  is open
  - $C_2$  is shorted
  - $C_2$  is open
  - $V_{in}$  has increased
9. Refer to Figure 8-1. If  $V_{in} = 1\text{ V p-p}$ , the output voltage  $V_{out}$  would be:
- undistorted
  - clipped on the negative peaks
  - clipped on the positive peaks
  - 0 V

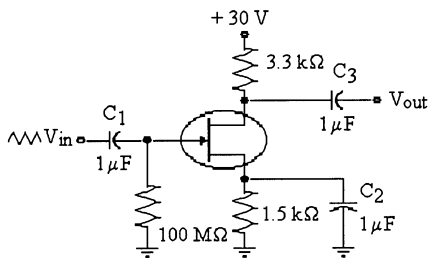

Figure 8-2

10. Refer to Figure 8-2. If  $I_D = 6\text{ mA}$ , the value of  $V_{GS}$  is:
- 9 V
  - 9 V
  - 19.8 V
  - 10.2 V
11. Refer to Figure 8-2. If  $g_m = 6500\ \mu\text{S}$  and an input signal of 125 mV p-p is applied to the gate, the output voltage  $V_{out}$  is:
- 2.68 V p-p
  - 0.8125 V p-p
  - 1.625 V p-p
  - 6.25 V p-p
12. Refer to Figure 8-2. If  $C_2$  opened, the output signal would:
- increase in value
  - decrease in value
  - not change
  - decrease and then increase
13. Refer to Figure 8-2. If  $I_D = 4\text{ mA}$ ,  $I_{DSS} = 16\text{ mA}$ , and  $V_{GS(off)} = -8\text{ V}$ ,  $V_{DS}$  would be:
- 19.2 V
  - 6 V
  - 10.8 V
  - 30 V

14. Refer to Figure 8-2. If  $g_m = 4000 \mu S$  and a signal of 75 mV rms is applied to the gate, the p-p output voltage is:
- 990 mV
  - 1.13 V p-p
  - 2.8 V p-p
  - 990 V p-p

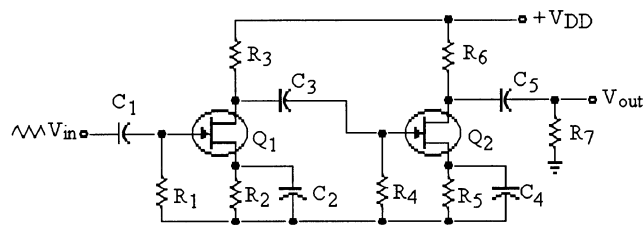

Figure 8-3

15. Refer to Figure 8-3. If  $C_4$  opened, the signal voltage at the drain of  $Q_2$  would:
- increase
  - decrease
  - remain the same
  - distort
16. Refer to Figure 8-3. If  $R_7$  were to increase in value,  $V_{out}$  would:
- increase
  - decrease
  - remain the same
  - distort
17. Refer to Figure 8-3. If  $C_2$  opened,  $V_{out}$  would:
- increase
  - decrease
  - remain the same
  - distort
18. Refer to Figure 8-3. If  $R_1$  opened,  $V_{out}$  would:
- increase
  - decrease
  - remain the same
  - distort
19. Refer to Figure 8-3. If  $C_3$  opened,  $V_{out}$  would:
- increase
  - decrease
  - remain the same
  - distort
20. Refer to Figure 8-3. If  $R_3$  opened,  $V_{out}$  would:
- increase
  - decrease
  - remain the same
  - distort

**Chapter 8: FET Amplifiers**

21. Refer to Figure 8-3. If  $R_5$  opened,  $V_{out}$  would:
  - a) increase
  - b) decrease
  - c) remain the same
  - d) distort
  
22. Refer to Figure 8-3. If the source-drain of  $Q_2$  shorted, the output signal from  $Q_1$  would:
  - a) increase
  - b) decrease
  - c) remain the same
  - d) distort
  
23. Refer to Figure 8-3. If  $A_{V1} = 18$  and  $A_{Vt} = 288$ , the value of  $A_{V2}$  would be:
  - a) 5184
  - b) 18
  - c) 49.18
  - d) 16
  
24. Refer to Figure 8-3. If  $C_4$  opened, the signal voltage at the drain of  $Q_1$  would:
  - a) increase
  - b) decrease
  - c) remain the same
  - d) distort
  
25. Refer to Figure 8-3. If  $V_{in}$  was increased in amplitude a little, the signal voltage at the source of  $Q_2$  would:
  - a) increase
  - b) decrease
  - c) remain the same
  - d) distort
  
26. What component of an FET operation needs to be at least ten times greater than  $R_D$  to ensure maximum voltage gain?
  - a)  $r'_{ds}$
  - b)  $R_S$
  - c)  $R_s$
  - d)  $g_m$
  
27. In a self-biased common-source amplifier (Textbook Fig 8-5), what purpose does resistor  $R_G$  serve?
  - a) Keeps the gate at approximately zero volts
  - b) Develops the gate-source bias current
  - c) Prevents loading of the ac signal source
  - d) Both a & c



28. A CS amplifier has a voltage gain of:
- $g_m R_d$
  - $g_m R_s$
  - $\frac{g_m R_s}{(1 + g_m R_d)}$
  - $\frac{g_m R_d}{(1 + g_m R_d)}$
29. The common-source JFET amplifier has:
- a high input impedance and a relatively low voltage gain
  - a high input impedance and a very high voltage gain
  - a high input impedance and a voltage gain less than 1
  - no voltage gain
30. Compared to a common-emitter amplifier, the voltage gain of a common-source amplifier is:
- about the same
  - much higher
  - much lower
  - about 1
31. When used as an amplifier, the JFET should operate:
- in the ohmic region
  - in the current-source region
  - in the saturation region
  - in the cut off region
32. A source follower has a voltage gain of:
- $g_m R_d$
  - $g_m R_s$
  - $\frac{g_m R_s}{(1 + g_m R_d)}$
  - $\frac{g_m R_d}{(1 + g_m R_d)}$
33. When the input signal is large, a source follower has:
- a voltage gain of less than one
  - a small distortion
  - a high input resistance
  - all of these
34. Changing \_\_\_\_\_ can control the voltage gain of a common-source amplifier.
- the input voltage
  - $g_m$
  - $V_{DD}$
  - $R_S$
35. Enhancement-mode MOSFETS function as active loads when:
- the gate is shorted to the source
  - the source is shorted to the drain
  - the gate is connected to the drain
  - the source is left disconnected

**Chapter 8: FET Amplifiers**

36. In IC's, the enhancement MOSFET is used mainly for:
- a) analog switching
  - b) digital switching
  - c) small signal amplification
  - d) dc amplification
37. The power gain of a common-gate amplifier is:
- a)  $\cong A_V$
  - b)  $\cong A_I$
  - c)  $> A_V$
  - d)  $> A_I$
38. Most small-signal E-MOSFETs are found in:
- a) heavy-current applications
  - b) discrete circuits
  - c) disk drives
  - d) integrated circuits
39. An E-MOSFET that operates at cutoff or in the ohmic region is an example of:
- a) a current source
  - b) an active load
  - c) a passive load
  - d) a switching device

1. Answer: b Difficulty: 2
2. Answer: b Difficulty: 2
3. Answer: a Difficulty: 2
4. Answer: a Difficulty: 2
5. Answer: c Difficulty: 2
6. Answer: d Difficulty: 2
7. Answer: d Difficulty: 3
8. Answer: c Difficulty: 3
9. Answer: a Difficulty: 2
10. Answer: b Difficulty: 2
11. Answer: a Difficulty: 2
12. Answer: b Difficulty: 2
13. Answer: c Difficulty: 2
14. Answer: c Difficulty: 3
15. Answer: b Difficulty: 2
16. Answer: a Difficulty: 3
17. Answer: b Difficulty: 2
18. Answer: c Difficulty: 3
19. Answer: b Difficulty: 2
20. Answer: b Difficulty: 2
21. Answer: b Difficulty: 2
22. Answer: c Difficulty: 3
23. Answer: d Difficulty: 2
24. Answer: c Difficulty: 3
25. Answer: c Difficulty: 3

**Chapter 8: FET Amplifiers**

- 26. Answer: a Difficulty: 2 Section: 1
- 27. Answer: d Difficulty: 3 Section: 2
- 28. Answer: a Difficulty: 3 Section: 2
- 29. Answer: a Difficulty: 1 Section: 2
- 30. Answer: a Difficulty: 2 Section: 2
- 31. Answer: b Difficulty: 3 Section: 1
- 32. Answer: b Difficulty: 2 Section: 4
- 33. Answer: d Difficulty: 1 Section: 4
- 34. Answer: b Difficulty: 2 Section: 4
- 35. Answer: c Difficulty: 3 Section: 2
- 36. Answer: b Difficulty: 2 Section: 2
- 37. Answer: a Difficulty: 2 Section: 4
- 38. Answer: d Difficulty: 2 Section: 4
- 39. Answer: d Difficulty: 2 Section: 4

## Chapter 9: Power Amplifiers

### *MULTIPLE CHOICE*

1. The class A amplifier is usually biased below cutoff.
  - a) true
  - b) false
2. Darlington pair transistors are often used in power amplifiers because the input impedance is very low.
  - a) true
  - b) false
3. A class B amplifier conducts \_\_\_\_\_ of the cycle.
  - a) 45°
  - b) 90°
  - c) 180°
  - d) 360°
4. The class of amplifiers that is the most efficient and has the most distortion is class \_\_\_\_\_ amplifiers.
  - a) A
  - b) B
  - c) C
  - d) AB
5. Push-pull amplifiers often use class \_\_\_\_\_ amplifiers.
  - a) A
  - b) B
  - c) C
  - d) AB
6. If a class A amplifier has a voltage gain of 50 and a current gain of 75. The power gain would be:
  - a) 50
  - b) 75
  - c) 1500
  - d) 3750
7. If a class A amplifier has  $R_C = 4.7 \text{ k}\Omega$  and  $R_E = 1.5 \text{ k}\Omega$  and  $V_{CC} = 24 \text{ V}$ ,  $I_{C(sat)}$  would be:
  - a) 5.1 mA
  - b) 16 mA
  - c) 3.87 mA
  - d) 0 mA
8. An application for an amplifier to operate in a linear mode is needed, the most likely choice would be a:
  - a) class A
  - b) class B
  - c) class C
  - d) class AB

Chapter 9: Power Amplifiers

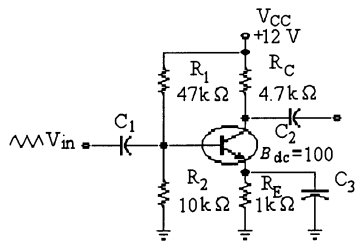

Figure 9-1

9. Refer to Figure 9-1. If  $R_1$  opened, and  $V_{in}$  at the base was large,  $V_{out}$  at the collector would:
- increase
  - decrease
  - remain the same
  - distort

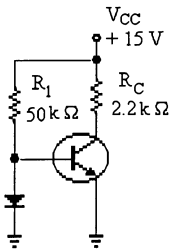

Figure 9-2

10. Refer to Figure 9-2. If the diode opened, this amplifier would be operating as class:
- A
  - B
  - C
  - AB
11. Refer to Figure 9-2. The purpose of the diode is:
- to bias the amplifier as class A
  - to bias the amplifier as class B
  - to bias the amplifier as class C
  - to bias the amplifier as class AB
12. A typical efficiency for a class A amplifier is about:
- 25%
  - 50%
  - 75%
  - 100%
13. The amplifier with the most distortion would be a \_\_\_\_\_ amplifier:
- class A
  - class B
  - class C
  - class AB

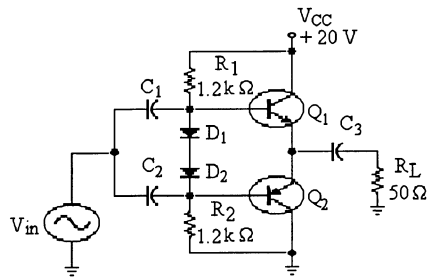

Figure 9-3

14. Refer to Figure 9-3. The emitter voltage with respect to ground is:
  - a) 10.7 V
  - b) 9.3 V
  - c) 0 V
  - d) 10 V
  
15. Refer to Figure 9-3. This amplifier only shows a positive alternation at the output. The possible trouble might be that:
  - a)  $C_3$  is shorted
  - b)  $BE_1$  is open
  - c)  $BE_2$  is open
  - d)  $R_1$  is open
  
16. Refer to Figure 9-3. The dc voltage across  $R_L$  was measured at 10 V. A possible problem, if any, might be:
  - a)  $C_1$  is open
  - b)  $C_3$  is shorted
  - c)  $R_1$  is open
  - d)  $C_3$  is open
  
17. Refer to Figure 9-3. During the positive input alternation,  $Q_1$  is \_\_\_\_\_ and  $Q_2$  is \_\_\_\_\_.
  - a) on, on
  - b) on, off
  - c) off, off
  - d) off, on
  
18. Refer to Figure 9-3. The purpose for the diodes  $D_1$  and  $D_2$  is:
  - a) to apply equal signals to each transistor
  - b) to allow the correct bias voltages on the two bases
  - c) to maintain constant bias with temperature changes
  - d) all of the above
  
19. Refer to Figure 9-3. The two transistors are called \_\_\_\_\_ type.
  - a) same
  - b) complementary
  - c) NPN
  - d) PNP

**Chapter 9: Power Amplifiers**

20. Refer to Figure 9-3. This circuit is operating as a:
- class A push-pull
  - class B push-pull
  - class C push-pull
  - class B
21. An application for a power amplifier to operate at radio frequencies is needed. The most likely choice would be a \_\_\_\_\_ amplifier.
- class A
  - class B
  - class C
  - class AB

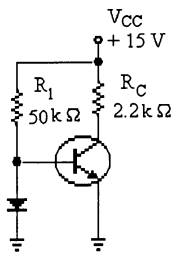

Figure 9-2

22. Refer to Figure 9-2. The approximate voltages on the base, collector, and emitter, respectively, are:
- 0.7 V, 6.8 V, 0 V
  - 0 V, 0 V, 0 V
  - 0.7 V, 15 V, 0 V
  - 0.7 V, 0 V, 15 V

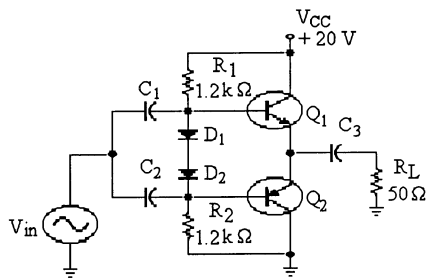

Figure 9-3

23. Refer to Figure 9-3. If  $R_L$  shows a zero signal voltage on an oscilloscope, the problem might be that:
- $C_3$  is open
  - $BE_1$  is open
  - $BE_2$  is open
  - $R_1$  is open



24. Refer to Figure 9-3. If there was no output signal, and the measured dc voltage of  $Q_1$  emitter was 0 V, the trouble might be:
- a)  $D_1$  is shorted
  - b)  $D_2$  is shorted
  - c)  $R_1$  is open
  - d) no trouble, everything is normal
25. Refer to Figure 9-3. Class AB amplifier is biased:
- a) at cutoff
  - b) slightly above the center of the load line
  - c) slightly above cutoff
  - d) at the center of the load line
26. In general, an amplifier may be considered to be a power amplifier if the amplifier has to dissipate:
- a)  $> 1/4$  W
  - b)  $> 2$  W
  - c)  $> 1$  W
  - d)  $> 5$  W
27. Heat sinks reduce the:
- a) transistor power
  - b) ambient temperature
  - c) junction temperature
  - d) collector current
28. An amplifier has two load lines because:
- a) it has ac and dc collector resistances
  - b) it has two equivalent circuits
  - c) dc acts one way and ac acts another
  - d) all of the above
29. When the Q point is at the center of the dc load line, a maximum \_\_\_\_\_ signal can be obtained.
- a) class A
  - b) class B
  - c) class C
  - d) none of the above
30. For maximum peak-to-peak output voltage, the Q point should be:
- a) near saturation
  - b) near cutoff
  - c) at the center of the dc load line
  - d) at the center of the ac load line
31. The ac load line is the same as the dc load line when the ac collector resistance equals the:
- a) dc emitter resistance
  - b) ac emitter resistance
  - c) dc collector resistance
  - d) supply voltage divided by collector current

## Chapter 9: Power Amplifiers

32. For a Q point near the center of the dc load line, clipping is more likely to occur on the:
- positive peak of input voltage
  - negative peak of output voltage
  - positive peak of output voltage
  - negative peak of emitter voltage
33. The ac load line usually:
- equals the dc load line
  - has less slope than the dc load line
  - is steeper than the dc load line
  - is horizontal
34. For a class "A" CE amplifier, the power dissipation,  $P_{DQ}$ :
- is maximum when there is no input signal
  - increases when the peak-to-peak load voltage increases
  - is zero with no input signal
  - is maximum when the transistor is driven to cutoff
35. A CE amplifier has a load power of 10 mW and the dc power is 215 mW. The efficiency is:
- 46.5%
  - 4.65%
  - 25%
  - 0%
36. To improve the efficiency of an amplifier, you have to:
- reduce load power
  - decrease unwanted power losses
  - reduce the supply voltage
  - increase the dc current
37. The quiescent collector current is the same as:
- ac collector current
  - ac load resistor current
  - dc collector current
  - none of the above
38. For a class B amplifier, collector current flows for:
- 270° of the input cycle
  - 180° of the input cycle
  - 360° of the input cycle
  - 90° of the input cycle
39. In a class B push-pull amplifier, the transistors are biased slightly above cutoff to avoid:
- unusually high efficiency
  - negative feedback
  - crossover distortion
  - a low input impedance

40. For a class B push-pull amplifier to work properly, the emitter diodes must:
- a) match the compensating diodes
  - b) be germanium and the compensating diodes must be silicon
  - c) be silicon and the compensating diodes must be germanium
  - d) not match the compensating diodes
41. For a class B push-pull amplifier, diode bias is used to:
- a) allow the transistors to conduct for  $360^\circ$
  - b) ensure thermal runaway
  - c) avoid thermal runaway
  - d) saturate the output transistors
42. The maximum efficiency of a class B push-pull amplifier is:
- a) 25 percent
  - b) 50 percent
  - c) 79 percent
  - d) 100 percent
43. Under no-signal or quiescent conditions, the transistors of a class B push-pull amplifier:
- a) have excessively high power dissipation
  - b) get quite hot
  - c) are in saturation
  - d) dissipate very little power
44. For certain applications with low-resistance loads, a push-pull amplifier using darlington transistors can be used to decrease the input resistance presented to the driving amplifier and avoid greatly reducing voltage gain.
- a) true
  - b) false
45. Power MOSFETs have several advantages over bipolar power transistors. Which of the following statements **is not** correct?
- a) Less signal power from the driver stage
  - b) Can switch on/off faster than bipolar power transistors
  - c) Can be easily connected in parallel to increase current capacity
  - d) Has a low voltage drop across the device under high voltage and current conditions
46. For a class C amplifier, collector current flows for:
- a)  $0^\circ$  of the input cycle
  - b) less than  $180^\circ$  of the input cycle
  - c)  $210^\circ$  of the input cycle
  - d)  $360^\circ$  of the input cycle
47. Class C amplifiers are almost always:
- a) transformer-coupled between stages
  - b) operated at audio frequencies
  - c) tuned RF amplifiers
  - d) wideband

**Chapter 9: Power Amplifiers**

48. The input signal of a class C amplifier:
- a) is negatively clamped at the base
  - b) is amplified and inverted
  - c) produces brief pulses of collector current
  - d) all of the above
49. The collector current of a class C amplifier:
- a) is an amplified version of the input voltage
  - b) has harmonics
  - c) is negatively clamped
  - d) flows for half a cycle

1. Answer: b Difficulty: 2
2. Answer: b Difficulty: 2
3. Answer: c Difficulty: 2
4. Answer: c Difficulty: 2
5. Answer: b Difficulty: 2
6. Answer: d Difficulty: 2
7. Answer: c Difficulty: 2
8. Answer: a Difficulty: 2
9. Answer: d Difficulty: 3
10. Answer: c Difficulty: 3
11. Answer: b Difficulty: 2
12. Answer: a Difficulty: 2
13. Answer: c Difficulty: 2
14. Answer: d Difficulty: 2
15. Answer: c Difficulty: 3
16. Answer: b Difficulty: 3
17. Answer: b Difficulty: 2
18. Answer: d Difficulty: 3
19. Answer: b Difficulty: 2
20. Answer: b Difficulty: 2
21. Answer: c Difficulty: 2
22. Answer: c Difficulty: 2
23. Answer: a Difficulty: 3
24. Answer: c Difficulty: 3
25. Answer: c Difficulty: 3

**Chapter 9: Power Amplifiers**

- 26. Answer: b Difficulty: 2 Section: 1
- 27. Answer: c Difficulty: 1 Section: 1
- 28. Answer: d Difficulty: 3 Section: 1
- 29. Answer: d Difficulty: 3 Section: 1
- 30. Answer: d Difficulty: 3 Section: 1
- 31. Answer: c Difficulty: 3 Section: 1
- 32. Answer: c Difficulty: 3 Section: 1
- 33. Answer: c Difficulty: 2 Section: 1
- 34. Answer: a Difficulty: 2 Section: 1
- 35. Answer: b Difficulty: 2 Section: 1
- 36. Answer: b Difficulty: 2 Section: 1
- 37. Answer: c Difficulty: 2 Section: 1
- 38. Answer: b Difficulty: 2 Section: 2
- 39. Answer: c Difficulty: 2 Section: 2
- 40. Answer: a Difficulty: 2 Section: 2
- 41. Answer: c Difficulty: 2 Section: 2
- 42. Answer: c Difficulty: 1 Section: 2
- 43. Answer: d Difficulty: 2 Section: 2
- 44. Answer: b Difficulty: 2 Section: 2
- 45. Answer: a Difficulty: 3 Section: 2
- 46. Answer: b Difficulty: 2 Section: 3
- 47. Answer: c Difficulty: 2 Section: 3
- 48. Answer: d Difficulty: 2 Section: 3
- 49. Answer: b Difficulty: 2 Section: 3

## Chapter 10: Amplifier Frequency Response

### MULTIPLE CHOICE

1. Coupling and bypass capacitors limit the low-frequency response of an amplifier.
  - a) true
  - b) false
2. High-frequency response is limited by the internal capacitances of a transistor.
  - a) true
  - b) false
3. At the cutoff frequency, the output is down by 3 dB.
  - a) true
  - b) false
4. An octave of frequency change is a ten-times change.
  - a) true
  - b) false
5. The bandwidth is the sum of the two cutoff frequencies.
  - a) true
  - b) false
6. If an amplifier has an output voltage of 12.7 V p-p at the midpoint of the frequency range, the output voltage at the cutoff frequency would be:
  - a) 12.7 V p-p
  - b) 4.49 V p-p
  - c) 5.89 V p-p
  - d) 8.98 V p-p
7. If an amplifier has an input signal voltage of 0.37 mV and an output voltage of 16.8 V, the voltage gain in dB would be:
  - a) 45.4 dB
  - b) 33.1 dB
  - c) 93.1 dB
  - d) 46.6 dB
8. If an amplifier has a voltage gain of 54 dB, and an input signal of 22 mV, the output signal voltage would be:
  - a) 11 V
  - b) 55.3 V
  - c) 2.45 V
  - d) 24.5 V
9. If an amplifier has a bandwidth of 47 kHz and a higher cutoff frequency of 104 kHz, the lower cutoff frequency would be:
  - a) 151 kHz
  - b) 57 kHz
  - c) 47 kHz
  - d) 104 kHz

**Chapter 10: Amplifier Frequency Response**

10. If an amplifier has an  $R_{in} = 950 \Omega$ , and a coupling capacitor of value  $3.3 \mu\text{F}$ , the approximate cutoff frequency would be:  
 a) 508 Hz  
 b) 50.8 kHz  
 c) 50.8 Hz  
 d) 5.08 Hz
11. The  $f_c$  of a certain RC network that has values of  $R = 470 \Omega$  and  $C = 0.005 \mu\text{F}$  is:  
 a) 67.8 kHz  
 b) 425 kHz  
 c) 213 kHz  
 d) 12 kHz

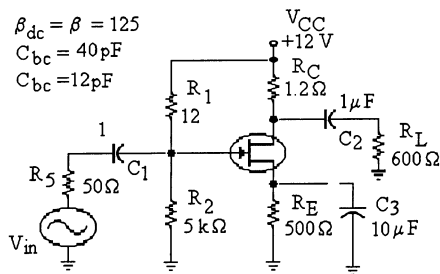

Figure 10-1

12. Refer to Figure 10-1. Low frequency response is affected by:  
 a)  $R_C$   
 b)  $C_{BE}$   
 c)  $C_3$   
 d) all of these
13. Refer to Figure 10-1. High frequency response is affected by:  
 a)  $R_C$ .  
 b)  $C_{BE}$ .  
 c)  $C_3$ .  
 d) all of these.
14. Refer to Figure 10-1. If the output voltage at the upper cutoff frequency was 7.19 V p-p, the output voltage that would be expected at the lower cutoff frequency is:  
 a) 5.08 V p-p  
 b) 7.19 V p-p  
 c) 10.17 V p-p  
 d) 2.11 V p-p
15. Refer to Figure 10-1. The output voltage at  $f_{c1} = 22 \text{ mV}$ .  $V_{out}$  at the midpoint frequency would be:  
 a) 22 mV  
 b) 17 mV  
 c) 31.1 mV  
 d) not enough data



16. Refer to Figure 10-1. The bandwidth of this amplifier is:
  - a) the sum of the upper and lower frequencies
  - b) the upper frequency divided by 0.707
  - c) the difference between the upper and lower frequencies
  - d) the lower frequency times 0.707
  
17. Refer to Figure 10-1. The capacitance  $C_{bc}$  affects:
  - a) high-frequency response
  - b) low-frequency response
  - c) mid-range response
  - d) nothing
  
18. Refer to Figure 10-1. A definite reduction in the output voltage is noticed. The trouble is:
  - a)  $C_3$  has shorted
  - b)  $C_1$  has opened
  - c)  $C_2$  has opened
  - d)  $C_3$  has opened
  
19. Refer to Figure 10-1. The reduction in the output at very high frequencies is due to:
  - a) the negative feedback effect of  $R_E$
  - b) the negative feedback effect of  $C_{bc}$
  - c) the positive feedback effect of  $V_{BE}$
  - d)  $R_L$  decreasing in value
  
20. Refer to Figure 10-1. If the output voltage at  $f_{c1} = 12$  mV, the output voltage at the midpoint frequency would be:
  - a) 12 mV
  - b) 12 mV p-p
  - c) 16.97 mV
  - d) 8.48 mV
  
21. Refer to Figure 10-1. If  $R_L$  increases in value, the output voltage would:
  - a) increase
  - b) decrease
  - c) remain the same
  - d) cannot be determined
  
22. If an RC network has a roll-off of 40 dB per decade, the total attenuation between the output voltage in the mid-range of the pass-band compared to a frequency of  $10f$  would be:
  - a) -3 dB
  - b) -20 dB
  - c) -23 dB
  - d) -43 dB
  
23. The cutoff frequency of a low pass filter occurs at:
  - a) -5 dB
  - b) -3 dB
  - c) +3 dB
  - d) -20 dB

**Chapter 10: Amplifier Frequency Response**

24. A high pass filter may be used to:
- a) pass low frequencies
  - b) pass high frequencies
  - c) pass frequencies between low and high
  - d) a or b
25. A roll-off of 20 dB per decade is equivalent to a roll-off of \_\_\_\_\_ per octave.
- a) 3 dB
  - b) 13 dB
  - c) 12 dB
  - d) 6 dB
26. Which of the following capacitances affects the high frequency response of an amplifier?
- a) Stray wiring capacitance
  - b) Internal PN junction capacitance
  - c) Coupling and bypass capacitors
  - d) Both a and b above
27. At low frequencies, the coupling capacitors produce a decrease in:
- a) input resistance
  - b) voltage gain
  - c) generator resistance
  - d) generator voltage
28. If the value of a feedback capacitor is 50 pF, what is the Miller capacitance when  $A_v = 200$  K?
- a) 1  $\mu$ F
  - b) 10  $\mu$ F
  - c) 100  $\mu$ F
  - d) 10 pF
29. The critical frequencies of an amplifier are the frequencies where the output voltage is:
- a) half of  $V_{OUT}$
  - b) 0.707 of  $V_{OUT}$
  - c) zero
  - d) 0.25 of  $V_{OUT}$
30. The voltage gain of an amplifier is 200. The decibel voltage gain is:
- a) 23 db
  - b) 46 db
  - c) 200
  - d) 106
31. If the voltage gain doubles, the decibel voltage gain increases by:
- a) A factor of 2
  - b) 3 dB
  - c) 6 dB
  - d) 10 dB

32. In the midband of a CE amplifier:
- a) the emitter is not at ac ground
  - b) the Miller effect kicks in
  - c) the voltage gain is maximum
  - d) the coupling and bypass capacitors appear open
33. If the power gain doubles, the decibel power gain increases by:
- a) a factor of 2
  - b) 3 dB
  - c) 6 dB
  - d) 10 dB
34. At low frequencies, the emitter-bypass capacitor:
- a) is no longer an ac short
  - b) reduces the input voltage
  - c) increases the output voltage
  - d) increases the voltage gain
35. Raising the frequency of 1 kHz by 2 octaves corresponds to a frequency of:
- a) 2 kHz
  - b) 500 Hz
  - c) 250 Hz
  - d) 2 MHz
36. The frequency response of an amplifier is a graph of:
- a) voltage versus current
  - b) voltage versus time
  - c) output voltage versus frequency
  - d) input voltage versus frequency
37. The voltage gain of an amplifier is 150. If the output voltage doubles (for the same amount of input voltage), the voltage gain equals:
- a) 21.7 db
  - b) 43.5 db
  - c) 49.5 db
  - d) 114 db
38. At the lower or upper cutoff frequency, the voltage gain is:
- a)  $0.35A_{mid}$
  - b)  $0.5A_{mid}$
  - c)  $0.707A_{mid}$
  - d)  $0.995A_{mid}$
39. Phase shift in the input of an RC circuit will approach  $90^\circ$  when:
- a) frequency approaches zero
  - b) frequency approaches maximum
  - c) frequency approaches mid-range
  - d) frequency approaches cutoff

**Chapter 10: Amplifier Frequency Response**

40. What effect does low frequency have on the emitter bypass RC circuit?
- a) Decreases impedance and increases voltage gain
  - b) Increases impedance and decreases voltage gain
  - c) Increases impedance and increases voltage gain
  - d) Decreases impedance and decreases voltage gain
41. For a lag network above the cutoff frequency, the voltage gain:
- a) decreases at the rate of 20 db per decade
  - b) increases at the rate of 6 db per octave
  - c) decreases at the rate of 6 db per octave
  - d) a and c above
42. Semilog graph paper has:
- a) two (2) linear axis
  - b) one vertical linear axis and one logarithmic horizontal axis
  - c) one horizontal linear axis and one vertical logarithmic axis
  - d) two (2) logarithmic axis
43. To effectively analyze an RC coupled amplifier high frequency response you need only consider the coupling and bypass capacitance, the internal capacitance can be ignored.
- a) true
  - b) false
44. The unity-gain frequency ( $f_T$ ) equals the product of mid-range voltage gain ( $A_{V(\text{mid})}$ ) and the:
- a) compensating capacitance
  - b)  $f_{cu}$
  - c) BW
  - d) load resistance
45. At the unity-gain frequency, the open-loop voltage gain is:
- a) 1
  - b)  $A_{\text{mid}}$
  - c) zero
  - d) very large

1. Answer: a Difficulty: 2
2. Answer: a Difficulty: 2
3. Answer: a Difficulty: 2
4. Answer: b Difficulty: 2
5. Answer: b Difficulty: 2
6. Answer: d Difficulty: 2
7. Answer: c Difficulty: 2
8. Answer: a Difficulty: 3
9. Answer: b Difficulty: 2
10. Answer: c Difficulty: 2
11. Answer: a Difficulty: 2
12. Answer: c Difficulty: 2
13. Answer: b Difficulty: 2
14. Answer: b Difficulty: 3
15. Answer: a Difficulty: 2
16. Answer: c Difficulty: 3
17. Answer: a Difficulty: 2
18. Answer: d Difficulty: 3
19. Answer: b Difficulty: 2
20. Answer: c Difficulty: 2
21. Answer: a Difficulty: 2
22. Answer: d Difficulty: 2
23. Answer: b Difficulty: 2
24. Answer: b Difficulty: 2
25. Answer: d Difficulty: 2

**Chapter 10: Amplifier Frequency Response**

- 26. Answer: d Difficulty: 1 Section: 1
- 27. Answer: d Difficulty: 2 Section: 1
- 28. Answer: d Difficulty: 2 Section: 1
- 29. Answer: b Difficulty: 2 Section: 2
- 30. Answer: b Difficulty: 2 Section: 2
- 31. Answer: b Difficulty: 2 Section: 2
- 32. Answer: c Difficulty: 2 Section: 2
- 33. Answer: b Difficulty: 2 Section: 2
- 34. Answer: a Difficulty: 2 Section: 2
- 35. Answer: a Difficulty: 2 Section: 3
- 36. Answer: c Difficulty: 1 Section: 3
- 37. Answer: c Difficulty: 1 Section: 3
- 38. Answer: c Difficulty: 1 Section: 3
- 39. Answer: a Difficulty: 2 Section: 3
- 40. Answer: b Difficulty: 2 Section: 3
- 41. Answer: d Difficulty: 3 Section: 3
- 42. Answer: b Difficulty: 1 Section: 3
- 43. Answer: b Difficulty: 2 Section: 5
- 44. Answer: c Difficulty: 2 Section: 5
- 45. Answer: a Difficulty: 2 Section: 5

## Chapter 11: Thyristors and Other Devices

### MULTIPLE CHOICE

1. The SCR is a device that can be triggered on by a pulse applied to the gate.  
a) true  
b) false
2. A device that conducts current in only one direction is called a diac.  
a) true  
b) false
3. A device that can be turned on or off by a gate pulse is called an SCS.  
a) true  
b) false
4. A triac can be turned on by a pulse at the gate.  
a) true  
b) false
5. A UJT is turned on by a negative pulse at the base.  
a) true  
b) false

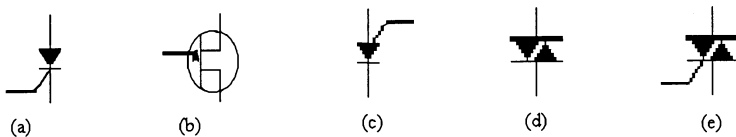

Figure 11-1

6. Refer to Figure 11-1 (a). The symbol is for:  
a) a triac  
b) a UJT  
c) a diac  
d) a PUT  
e) an SCR
7. Refer to Figure 11-1 (b). The symbol is for:  
a) a triac  
b) a UJT  
c) a diac  
d) a PUT  
e) an SCR
8. Refer to Figure 11-1 (c). The symbol is for:  
a) a triac  
b) a UJT  
c) a diac  
d) a PUT  
e) an SCR

**Chapter 11: Thyristors and Other Devices**

9. Refer to Figure 11-1 (d). The symbol is for:
  - a) a triac
  - b) a UJT
  - c) a diac
  - d) a PUT
  - e) an SCR
  
10. Refer to Figure 11-1 (e). The symbol is for:
  - a) a triac
  - b) a UJT
  - c) a diac
  - d) a PUT
  - e) an SCR
  
11. A good choice to trigger a triac would be:
  - a) a UJT
  - b) an SCR
  - c) a diac
  - d) a Schottky diode
  
12. The best choice to operate a small variable speed ac motor is a(n):
  - a) triac
  - b) diac
  - c) SCR
  - d) UJT
  - e) PUT
  
13. The best choice to shut down a dc power supply in case of a high voltage condition is a(n):
  - a) triac
  - b) diac
  - c) SCR
  - d) UJT
  - e) PUT
  
14. A good choice to turn on a device at a particular voltage would be a(n):
  - a) triac
  - b) diac
  - c) SCR
  - d) UJT
  - e) PUT
  
15. The most likely device to be used in an oscillator is a(n):
  - a) triac
  - b) diac
  - c) SCR
  - d) UJT
  - e) PUT
  
16. A typical use for an optical coupler might be:
  - a) to connect telephone lines to electronic equipment
  - b) to transfer signals to a fiber optic cable
  - c) to isolate one circuit from another
  - d) all of these



17. An SCS has a unique ability to:
  - a) be turned on or off with a pulse
  - b) be turned off only with a pulse
  - c) control a PUT
  - d) all of these
  
18. If an SCR starts to conduct when a gate current is established, what will occur when the gate circuit is interrupted?
  - a) The SCR will turn off.
  - b) The SCR current will increase.
  - c) The SCR will continue to conduct.
  - d) The SCR gate current will increase.
  
19. An SCR will turn off when the voltage across it is:
  - a) increased to the supply voltage
  - b) decreased to near 0 V
  - c) timed out
  - d) decreased by the value of the gate voltage
  
20. A triac is used on ac because:
  - a) it conducts on both alternations
  - b) it is turned off when the ac voltage reaches zero
  - c) it can deliver more power to the load in a cycle
  - d) all of these
  
21. A device is needed to trigger an SCR. A good one to use might be:
  - a) an SCR
  - b) a UJT
  - c) a Schockley diode
  - d) a PUT
  
22. The best device to be used to control a dc motor is:
  - a) triac
  - b) PUT
  - c) SCR
  - d) diac
  
23. An SCR is used to control the speed of a dc motor by \_\_\_\_\_ the \_\_\_\_\_ of the pulse delivered to the motor.
  - a) varying, width
  - b) increasing, amplitude
  - c) decreasing, gate width
  - d) none of these
  
24. Which of the following applications would be likely to use a diac?
  - a) A battery charger
  - b) An oscillator
  - c) A high frequency amplifier
  - d) A lamp dimmer

## Chapter 11: Thyristors and Other Devices

25. A light dimmer circuit using an SCR is tested and  $I_G = 0\text{mA}$  was found. The light is still on. The trouble might be one of the following:
- the SCR is open
  - the switch is faulty
  - the gate circuit is shorted
  - this is normal, nothing is wrong
26. A thyristor can be used as:
- a resistor
  - an amplifier
  - a switch
  - a power source
27. The minimum input current that can turn on a thyristor is called the:
- holding current
  - switching current
  - breakdown current
  - low-current dropout current
28. The minimum current that keeps a latch closed is called the:
- pick-up current
  - critical rate of current rise
  - trigger current
  - holding current
29. The only way to close a four-layer diode is with:
- a trigger input applied to the gate
  - forward breakover voltage
  - low-current dropout
  - none of the above
30. The only way to stop an SCR that is conducting is by:
- a positive trigger
  - low-current drop out
  - breakover
  - reverse-bias triggering
31. A silicon controlled rectifier has:
- two external leads
  - three external leads
  - four external leads
  - three doped regions
32. An SCR is usually turned on by:
- breakover
  - a gate trigger
  - breakdown
  - holding current
33. SCRs are:
- low-power devices
  - four-layer diodes
  - high-current devices
  - bi-directional

34. The trigger voltage of an SCR is closest to:  
a) 0 V  
b) 0.7 V  
c) 4 V  
d) breakover voltage
35. The voltage across a conducting SCR:  
a) equals the breakover voltage  
b) is exactly zero  
c) decreases with more anode current  
d) is quite low
36. Disconnecting the gate lead in a conducting SCR will:  
a) turn it off  
b) not turn it off  
c) destroy it  
d) increase the anode current
37. The angle at which an SCR fires is called the:  
a) displacement angle  
b) firing angle  
c) the peak angle  
d) conduction angle
38. The forced commutation method requires momentarily forcing current in the direction opposite to the reverse conduction so that the net reverse current is reduced below the holding value.  
a) true  
b) false
39. SCR's are:  
a) low-power devices  
b) four-layer diodes  
c) high-current devices  
d) bi-directional
40. Once a diac is conducting, the only way to turn it off is with:  
a) low-current dropout  
b) breakover  
c) a negative gate voltage  
d) a positive gate voltage
41. The diac is equivalent to:  
a) two four-layered diodes in parallel  
b) two SCRs in parallel  
c) two four-layer diodes in series  
d) two triacs in parallel
42. The diac is a:  
a) transistor  
b) unidirectional device  
c) three-layer device  
d) bi-directional device

## Chapter 11: Thyristors and Other Devices

43. A triac acts like:
- two SCRs in parallel
  - two SCRs in series
  - two diacs in parallel
  - a normal transistor
44. A triac:
- can trigger only on positive gate voltages
  - can trigger only on negative gate voltages
  - can be triggered by either a positive or a negative gate voltage
  - cannot be triggered with gate voltages
45. The triac is equivalent to:
- a four-layer diode
  - two diacs in parallel
  - a thyristor with a gate lead
  - two SCRs in parallel
46. A silicon-controlled switch:
- has only 1 gate lead
  - has two gate leads
  - can only be turned off with low-current dropout
  - is bi-directional
47. A UJT has:
- two base leads
  - one emitter lead
  - two emitter and one base leads
  - both a and b above
48. For a UJT, the intrinsic standoff ratio is:
- equal to 1
  - always greater than 1
  - always less than 1
  - usually around 1 k $\omega$  or so
49. For maximum sensitivity to light, the gate of a light-activated SCR, LASCR, should be:
- shorted to the cathode
  - shorted to ground
  - shorted to both the cathode and the anode
  - left open
50. The PUT (Programmable Unijunction Transistor) is actually a type of:
- thyristor
  - FET device
  - triac
  - SCR
51. An optoisolator is a device containing \_\_\_\_\_ in a single package.
- a photodiode and an optotransmitter
  - a phototransistor and an optosensor
  - an optotransmitter and an LED
  - an optotransmitter and an optosensor

52. The slot type optical sensor (Phototransistor couplers) has a slot separating \_\_\_\_\_.
- a) a phototransistor and an optosensor
  - b) a photodiode and an optosensor
  - c) an optotransmitter and an LED
  - d) an LED and an optotransistor

**Chapter 11: Thyristors and Other Devices**

1. Answer: a Difficulty: 2
2. Answer: b Difficulty: 2
3. Answer: a Difficulty: 2
4. Answer: a Difficulty: 2
5. Answer: b Difficulty: 2
6. Answer: e Difficulty: 2
7. Answer: b Difficulty: 2
8. Answer: d Difficulty: 2
9. Answer: c Difficulty: 2
10. Answer: a Difficulty: 2
11. Answer: c Difficulty: 2
12. Answer: a Difficulty: 2
13. Answer: c Difficulty: 3
14. Answer: e Difficulty: 2
15. Answer: d Difficulty: 2
16. Answer: d Difficulty: 2
17. Answer: a Difficulty: 2
18. Answer: c Difficulty: 3
19. Answer: b Difficulty: 2
20. Answer: d Difficulty: 2
21. Answer: b Difficulty: 3
22. Answer: c Difficulty: 2
23. Answer: a Difficulty: 3
24. Answer: d Difficulty: 2
25. Answer: d Difficulty: 3

- 26. Answer: c Difficulty: 2 Section: 1
- 27. Answer: b Difficulty: 2 Section: 1
- 28. Answer: d Difficulty: 2 Section: 1
- 29. Answer: b Difficulty: 3 Section: 1
- 30. Answer: b Difficulty: 2 Section: 2
- 31. Answer: b Difficulty: 1 Section: 2
- 32. Answer: b Difficulty: 2 Section: 2
- 33. Answer: c Difficulty: 2 Section: 2
- 34. Answer: b Difficulty: 2 Section: 2
- 35. Answer: b Difficulty: 2 Section: 2
- 36. Answer: d Difficulty: 3 Section: 2
- 37. Answer: b Difficulty: 2 Section: 2
- 38. Answer: b Difficulty: 3 Section: 2
- 39. Answer: c Difficulty: 2 Section: 3
- 40. Answer: a Difficulty: 2 Section: 4
- 41. Answer: a Difficulty: 3 Section: 4
- 42. Answer: d Difficulty: 2 Section: 4
- 43. Answer: a Difficulty: 1 Section: 4
- 44. Answer: c Difficulty: 2 Section: 4
- 45. Answer: d Difficulty: 2 Section: 4
- 46. Answer: b Difficulty: 2 Section: 5
- 47. Answer: d Difficulty: 2 Section: 6
- 48. Answer: c Difficulty: 2 Section: 6
- 49. Answer: d Difficulty: 2 Section: 9
- 50. Answer: a Difficulty: 2 Section: 7

**Chapter 11: Thyristors and Other Devices**

51. Answer: d Difficulty: 2 Section: 10

52. Answer: d Difficulty: 3 Section: 10



## Chapter 12: Operational Amplifiers

### MULTIPLE CHOICE

1. A good op-amp has high voltage gain, low output impedance, and high input impedance.  
a) true  
b) false
2. An inverting amplifier has an input resistance equal to the input resistor.  
a) true  
b) false
3. CMRR is the measure of an op-amp's voltage gain for an inverting amplifier.  
a) true  
b) false
4. All op-amp configurations must use negative feedback.  
a) true  
b) false
5. A voltage follower has a very high input impedance, and is often used as a high voltage gain amplifier.  
a) true  
b) false

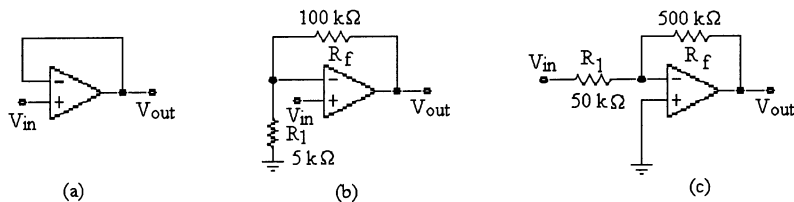

Figure 12-1

6. Refer to Figure 12-1. Which circuit is the inverting amplifier?  
a) (a)  
b) (b)  
c) (c)  
d) None of the above
7. Refer to Figure 12-1. Which circuit is a voltage follower?  
a) (a)  
b) (b)  
c) (c)  
d) None of the above
8. Refer to Figure 12-1. Which circuit is the non-inverting amplifier?  
a) (a)  
b) (b)  
c) (c)  
d) None of the above

**Chapter 12: Operational Amplifiers**

9. Refer to Figure 12-1. Which circuit has a voltage gain of 1?
  - a) (a)
  - b) (b)
  - c) (c)
  - d) None of the above
10. See Figure 12-1. Which circuit has an input impedance of about 5 k $\Omega$ ?
  - a) (a)
  - b) (b)
  - c) (c)
  - d) None of the above
11. Refer to Figure 12-1. Which circuit has a voltage gain of 10?
  - a) (a)
  - b) (b)
  - c) (c)
  - d) None of the above
12. Refer to Figure 12-1. Which circuit has a voltage gain of 20?
  - a) (a)
  - b) (b)
  - c) (c)
  - d) None of the above
13. Refer to Figure 12-1 (a). If this circuit has a  $V_{in} = 12$  V p-p, the value of  $V_{out}$  would be:
  - a) 20 V
  - b) -20 V
  - c) 8.48 V p-p
  - d) 12 V p-p
14. Refer to Figure 12-1 (b). If this circuit has a  $V_{in} = 0.7$ ,  $V_{out}$  would be:
  - a) 14.7 V
  - b) -14.7 V
  - c) 14 V
  - d) 0 V
15. Refer to Figure 12-1 (c).  $V_{in} = -6$  V. The value of  $V_{out}$  is:
  - a) 60 V
  - b) -60 V
  - c) about -16 V
  - d) about 16 V
16. See Figure 12-1. If these three circuits were connected as a multiple-stage amplifier, the total voltage gain would be:
  - a) 1
  - b) 10
  - c) 21
  - d) 210

17. Refer to Figure 12-1 (c). If  $R_f$  is changed to  $1\text{ M}\Omega$ , the new  $A_{cl}$  would be:
- 20
  - 20
  - 21
  - 21
18. Refer to Figure 12-1 (c). If an amplifier with an input impedance of  $12\text{ k}\Omega$  and the same voltage gain is needed, the new value of  $R_f$  would be \_\_\_\_\_ and the new value of  $R_F$  would be \_\_\_\_\_.
- $10\text{ k}\Omega$ ,  $100\text{ k}\Omega$
  - $13.3\text{ k}\Omega$ ,  $120\text{ k}\Omega$
  - $12\text{ k}\Omega$ ,  $108\text{ k}\Omega$
  - $12\text{ k}\Omega$ ,  $120\text{ k}\Omega$

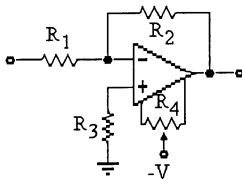

Figure 12-2

19. Refer to Figure 12-2. This op-amp has a slew rate of  $1.33\text{ V}/\mu\text{s}$ . How long would it take to change the output voltage from  $-12\text{ V}$  to  $+12\text{ V}$ ?
- $18\ \mu\text{s}$
  - $16\ \mu\text{s}$
  - $-18\ \mu\text{s}$
  - $48\ \mu\text{s}$
20. Refer to Figure 12-2. Which components are used to set input impedance and voltage gain?
- $R_4$
  - $R_3$
  - $R_1$  and  $R_2$
  - $R_3$  and  $R_4$
21. Refer to Figure 12-2. Which components are used for offset voltage compensation?
- $R_4$
  - $R_3$
  - $R_1$  and  $R_2$
  - $R_2$
22. Refer to Figure 12-2. Which components are used for bias current compensation?
- $R_4$
  - $R_3$
  - $R_1$  and  $R_2$
  - $R_2$

## Chapter 12: Operational Amplifiers

23. Refer to Figure 12-2. The purpose of  $R_1$  and  $R_2$  is:
  - a) for bias current compensation
  - b) for input offset voltage compensation
  - c) to set input impedance only
  - d) to set input impedance and voltage gain
24. It takes an op-amp 22  $\mu\text{s}$  to change its output from -15 V to +15 V. The slew rate for this amplifier is:
  - a) 1.36 V/ $\mu\text{s}$
  - b) 0.68 V/ $\mu\text{s}$
  - c) -0.68 V/ $\mu\text{s}$
  - d) -1.36 V/ $\mu\text{s}$
25. A voltage follower amplifier comes to you for service. You find the voltage gain to be 5.5 and the input impedance is 22 k $\Omega$ . The probable fault in this amplifier is, if any:
  - a) the gain is too low for this type of amplifier
  - b) the input impedance is too high for this amplifier
  - c) nothing is wrong. The trouble must be somewhere else
  - d) cannot be determined
26. The op amp can amplify:
  - a) ac signals only
  - b) dc signals only
  - c) both ac and dc signals
  - d) neither ac nor dc signals
27. The typical input stage of an op amp has a:
  - a) single-ended input and single-ended output
  - b) single-ended input and differential output
  - c) differential input and single-ended output
  - d) differential input and differential output
28. The common-mode signal is applied to:
  - a) the noninverting input
  - b) the inverting input
  - c) both inputs
  - d) top of the tail resistor
29. If an Op Amp were perfect, the CMRR would be:
  - a) zero
  - b) infinite
  - c) equal to the differential gain
  - d) both b and c above
30. In an Op Amp, the CMRR is limited mostly by the:
  - a) CMRR of the op amp
  - b) gain-bandwidth product
  - c) supply voltages
  - d) tolerance of the resistors

31. The open-loop voltage gain ( $A_{o1}$ ) of an Op Amp is the:
  - a) external voltage gain the device is capable of
  - b) internal voltage gain the device is capable of
  - c) most controlled parameter
  - d) same as  $A_{cm}$
32. The input offset current is usually:
  - a) less than the input bias current
  - b) equal to zero
  - c) less than the input offset voltage
  - d) unimportant when a base resistor is used
33. With both inputs grounded, the only offset that produces an error is the:
  - a) input offset current
  - b) input bias current
  - c) input offset voltage
  - d) input short circuit current
34. The input offset current equals the:
  - a) difference between two base currents
  - b) average of two base currents
  - c) collector current divided by current gain
  - d) difference between two base-emitter voltages
35. The ideal Op Amp has:
  - a) infinite input impedance and zero output impedance
  - b) infinite output impedance and zero input impedance
  - c) infinite voltage gain and infinite bandwidth
  - d) both a and c
36. The two basic ways of specifying input impedance of an Op Amp are:
  - a) differential and extremely high
  - b) differential and common-loop
  - c) differential and common-mode
  - d) closed-loop and common-mode
37. The initial slope of a sine wave is directly proportional to the:
  - a) slew rate
  - b) voltage gain
  - c) voltage gain
  - d) capacitance
38. When the initial slope of a sine wave is greater than the slew rate:
  - a) distortion occurs
  - b) voltage gain is maximum
  - c) voltage gain is maximum
  - d) the op amp works best
39. When slew-rate distortion of a sine wave occurs, the output:
  - a) is larger
  - b) appears triangular
  - c) is normal
  - d) has no offset

## Chapter 12: Operational Amplifiers

40. With negative feedback, the returning signal:
  - a) aids the input signal
  - b) opposes the input signal
  - c) is proportional to output current
  - d) is proportional to differential voltage gain
41. The closed-loop voltage gain of an inverting amplifier equals:
  - a) the ratio of the input resistance to the feedback resistance
  - b) the open-loop voltage gain
  - c) the feedback resistance divided by the input resistance
  - d) the input resistance
42. The noninverting amplifier has a:
  - a) large closed-loop voltage gain
  - b) small open-loop voltage gain
  - c) small closed-loop input impedance
  - d) small closed-loop output impedance
43. The voltage follower has a:
  - a) closed-loop voltage gain of unity
  - b) small open-loop voltage gain
  - c) closed-loop bandwidth of zero
  - d) large closed-loop output impedance
44. The feedback fraction "B":
  - a) is always less than 1
  - b) is usually greater than 1
  - c) may equal 1
  - d) may not equal 1
45. The loop gain  $A_{OL}B$ :
  - a) is usually much smaller than 1
  - b) is usually much greater than 1
  - c) may not equal 1
  - d) is between 0 and 1
46. Current cannot flow to ground through:
  - a) a mechanical ground
  - b) an ac ground
  - c) a virtual ground
  - d) an ordinary ground
47. The closed-loop input impedance in a noninverting amplifier is:
  - a) much greater than the open-loop input impedance
  - b) equal to the open-loop input impedance
  - c) sometimes less than the open-loop input impedance
  - d) ideally zero
48. The imbalances of the internal circuitry of an op amp are lumped into one value called the \_\_\_\_\_.
  - a) imbalance factor
  - b) input offset voltage
  - c) output offset voltage
  - d) balance offset factor

49. The voltage gain of an op amp is unity at the:
- a) cutoff frequency
  - b) unity-gain frequency
  - c) generator frequency
  - d) power bandwidth
50. For a given op amp, which of these is constant?
- a.  $f_{C(CL)}$
  - b. feedback voltage
  - c.  $A_{OL}$
  - d.  $A_{OL} f_{c(OL)}$
51. If the unit-gain frequency is 10 MHz and the mid-band open-loop voltage gain is 200,000, the cutoff frequency is:
- a) 5 kHz
  - b) 50 Hz
  - c) 5 Hz
  - d) 25 MHz

**Chapter 12: Operational Amplifiers**

1. Answer: a Difficulty: 2
2. Answer: a Difficulty: 2
3. Answer: b Difficulty: 2
4. Answer: b Difficulty: 2
5. Answer: b Difficulty: 2
6. Answer: c Difficulty: 2
7. Answer: a Difficulty: 2
8. Answer: b Difficulty: 2
9. Answer: a Difficulty: 2
10. Answer: d Difficulty: 3
11. Answer: c Difficulty: 2
12. Answer: d Difficulty: 2
13. Answer: d Difficulty: 2
14. Answer: a Difficulty: 2
15. Answer: a Difficulty: 2
16. Answer: d Difficulty: 2
17. Answer: b Difficulty: 2
18. Answer: d Difficulty: 2
19. Answer: a Difficulty: 2
20. Answer: c Difficulty: 2
21. Answer: a Difficulty: 3
22. Answer: b Difficulty: 2
23. Answer: d Difficulty: 2
24. Answer: a Difficulty: 2
25. Answer: d Difficulty: 3



26. Answer: c Difficulty: 1 Section: 1
27. Answer: c Difficulty: 1 Section: 1
28. Answer: c Difficulty: 1 Section: 2
29. Answer: c Difficulty: 2 Section: 2
30. Answer: a Difficulty: 2 Section: 2
31. Answer: b Difficulty: 2 Section: 2
32. Answer: a Difficulty: 2 Section: 2
33. Answer: c Difficulty: 2 Section: 2
34. Answer: a Difficulty: 2 Section: 2
35. Answer: a Difficulty: 2 Section: 1
36. Answer: c Difficulty: 2 Section: 2
37. Answer: a Difficulty: 2 Section: 2
38. Answer: a Difficulty: 2 Section: 2
39. Answer: b Difficulty: 2 Section: 2
40. Answer: b Difficulty: 2 Section: 3
41. Answer: c Difficulty: 2 Section: 4
42. Answer: c Difficulty: 2 Section: 4
43. Answer: a Difficulty: 2 Section: 4
44. Answer: a Difficulty: 2 Section: 4
45. Answer: b Difficulty: 2 Section: 4
46. Answer: c Difficulty: 2 Section: 4
47. Answer: a Difficulty: 2 Section: 4
48. Answer: b Difficulty: 2 Section: 6
49. Answer: b Difficulty: 2 Section: 6
50. Answer: d Difficulty: 3 Section: 6

**Chapter 12: Operational Amplifiers**

51. Answer: b Difficulty: 1 Section: 6

## Chapter 13: Basic Op-Amp Applications

### MULTIPLE CHOICE

1. An op-amp comparator has an output dependent upon the polarities of the two inputs.  
a) true  
b) false
2. The output voltage of a summing amplifier is proportional to the product of the input voltages.  
a) true  
b) false
3. Integration is a mathematical process for determining the area under a curve.  
a) true  
b) false
4. A square wave input to an op-amp integrator will produce a sine wave output.  
a) true  
b) false
5. Bounding allows the op-amp to have unlimited output voltage.  
a) true  
b) false
6. An op-amp has an open-loop gain of 100,000.  $V_{sat} = +/-12\text{ V}$ . A differential signal voltage of  $150\ \mu\text{V}$  p-p is applied between the inputs. What is the output voltage?  
a) 12 V  
b) -12 V  
c) 12 V p-p  
d) 24 V p-p
7. A summing amplifier can:  
a) add dc voltages  
b) add ac voltages  
c) add dc to ac voltages  
d) all of these

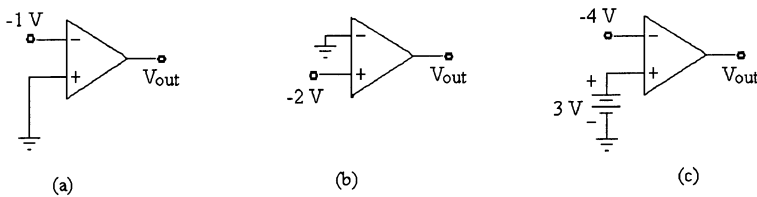

Figure 13-1

**Chapter 13: Basic Op-Amp Applications**

8. Refer to Figure 13-1 (a). If  $V_{CC} = 15\text{ V}$ , the approximate output voltage is:
  - a) 1 V
  - b) -1 V
  - c) 13 V
  - d) -13 V
9. Refer to Figure 13-1 (b). If  $V_{sat} = +/-12\text{ V}$ , the approximate output voltage is:
  - a) 12 V
  - b) -12 V
  - c) 2 V
  - d) -2 V
10. Refer to Figure 13-1 (c). If  $V_{sat} = +/-10\text{ V}$ , the approximate value of  $V_{OUT}$  is:
  - a) -1 V
  - b) 1 V
  - c) -6 V
  - d) none of the above
11. Refer to Figure 13-1 (c). With the inputs shown, the output voltage would be:
  - a) 7 V
  - b) -7 V
  - c)  $+V_{sat}$
  - d)  $-V_{sat}$

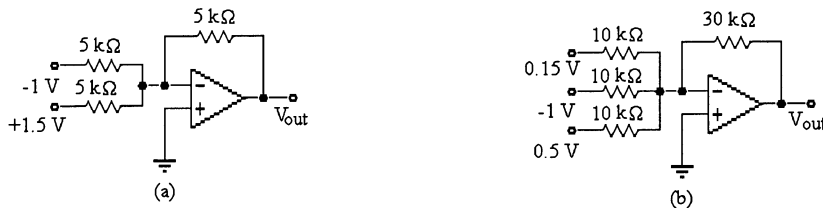

Figure 13-2

12. Refer to Figure 13-2 (a). If a solder splash shorted the two ends of the feedback resistor to each other, the output voltage would be:
  - a) 0.5 V
  - b) -0.5 V
  - c) 0 V
  - d)  $-V_{sat}$
13. Refer to Figure 13-2 (b). A voltmeter placed from the inverting input to ground would read:
  - a) -0.925 V
  - b) -2.775 V
  - c) 2.775 V
  - d)  $\approx 0\text{ V}$

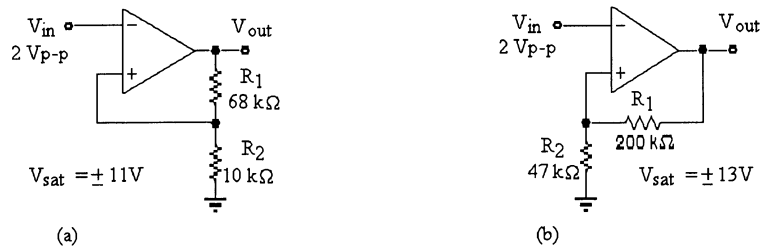

Figure 13-3

14. Refer to Figure 13-3 (a). This circuit is known as:
  - a) a multivibrator
  - b) a zero level detector
  - c) a non-zero level detector
  - d) a non-inverting amplifier
15. Refer to Figure 13-3 (b). This type of circuit will usually have:
  - a) a square wave output if the input is a sine wave
  - b) a triangle wave output
  - c) a ramp output for a square wave input
  - d) none of these
16. Refer to Figure 13-3 (b). The output voltage with the inputs as shown is:
  - a)  $+V_{sat}$
  - b)  $-V_{sat}$
  - c)  $26 V_{p-p}$
  - d)  $17.06 V_{p-p}$

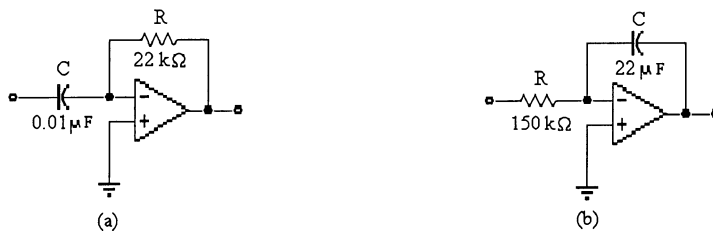

Figure 13-4

17. See Figure 13-4. This circuit is known as:
  - a) a non-inverting amplifier
  - b) an integrator
  - c) a differentiator
  - d) a summing amplifier
18. Refer to Figure 13-4. Which of these circuits is known as a differentiator?
  - a) (a)
  - b) (b)
  - c) None of these

**Chapter 13: Basic Op-Amp Applications**

19. Refer to Figure 13-4 (b). A square wave input is applied to this amplifier. The output voltage is most likely to be:
  - a) a square wave
  - b) a triangle wave
  - c) a sine wave
  - d) no output
  
20. A Schmitt trigger is:
  - a) a comparator with hysteresis
  - b) a comparator with one trigger point
  - c) a comparator with two trigger points
  - d) a and c
  
21. An op-amp has an open-loop gain of 90,000.  $V_{sat} = +/-13$  V. A differential voltage of  $0.1 V_{p-p}$  is applied between the inputs. The output voltage is:
  - a) 13 V
  - b) -13 V
  - c)  $13 V_{p-p}$
  - d)  $26 V_{p-p}$
  
22. The output of a Schmitt trigger is a:
  - a) triangle wave
  - b) sine wave
  - c) sawtooth
  - d) square wave
  
23. An integrated circuit:
  - a) uses a capacitor in its feedback circuit
  - b) produces a ramp voltage at its output for a step input voltage
  - c) uses an inductor in its feedback circuit
  - d) a and b
  
24. A differential circuit:
  - a) uses a resistor in its feedback circuit
  - b) uses a capacitor in its feedback circuit
  - c) produces a ramp voltage at its output for a step input voltage
  - d) a and c
  
25. Hysteresis voltage is defined as:
  - a) the voltage of the lower trigger point
  - b) the voltage of the upper trigger point
  - c) the difference in voltage between the upper and the lower trigger points
  - d) the sum of voltages of the upper and the lower trigger points
  
26. A comparator is an example of a(n):
  - a) active filter
  - b) current source
  - c) linear circuit
  - d) nonlinear circuit

27. If the input to a comparator is a sine wave, the output is a:
- a) ramp voltage
  - b) sine wave
  - c) rectangular wave
  - d) sawtooth wave
28. A zero crossing detector is a:
- a) comparator with a sine-wave output
  - b) comparator with a trip point referenced to zero
  - c) peak detector
  - d) limiter
29. A window comparator:
- a) has only one usable threshold
  - b) uses hysteresis to speed up response
  - c) clamps the input positively
  - d) detects an input voltage between two limits
30. A Schmitt trigger has:
- a) only one trip point
  - b) only negative feedback
  - c) two slightly different trip points
  - d) a triangular output
31. A Schmitt trigger is a comparator with:
- a) negative feedback
  - b) positive feedback
  - c) neither a nor b
  - d) both a and b
32. The \_\_\_\_\_ circuit overcomes the problem of false switching caused by noise on the input(s).
- a) input buffer
  - b) Schmitt trigger
  - c) input noise rejecter
  - d) differentiator
33. The amount of hysteresis in a Schmitt trigger is defined by the \_\_\_\_\_ of the two trigger levels.
- a) difference  $V_{UTP} - V_{LTP}$
  - b) product  $V_{UTP} \times V_{LTP}$
  - c) division  $\frac{V_{UTP}}{V_{LTP}}$
  - d) sum  $V_{UTP} + V_{LTP}$
34. Output Bounding is the process of \_\_\_\_\_ the output voltage range of a comparator.
- a) extending
  - b) limiting
  - c) comparing
  - d) filtering

**Chapter 13: Basic Op-Amp Applications**

35. If all the resistors in a summing amplifier are equal, the output will be equal to the \_\_\_\_\_.
- a) average of the individual inputs
  - b) inverted average of the individual inputs
  - c) sum of the individual inputs
  - d) inverted sum of the individual inputs
36. If the value of resistor  $R_f$  in a averaging amplifier circuit is equal to the value of one input resistor divided by the number of inputs, the output will be equal to:
- a) average of the individual inputs
  - b) inverted average of the individual inputs
  - c) sum of the individual inputs
  - d) inverted sum of the individual inputs
37. The \_\_\_\_\_ input makes the summing amplifier circuit possible.
- a) virtual ground at the noninverting
  - b) virtual ground at the inverting
  - c) low voltage
  - d) high voltage
38. A D/A converter is an application of the:
- a) adjustable bandwidth circuit
  - b) noninverting amplifier
  - c) voltage-to-current converter
  - d) scaling adder
39. In an op-amp integrator, the current through the input resistor flows into the:
- a) inverting input
  - b) noninverting input
  - c) bypass capacitor
  - d) feedback capacitor
40. A mathematical operation that determines the rate of change of a curve is called \_\_\_\_\_.
- a) differentiation
  - b) integration
  - c) curve averaging
  - d) linear regression
41. A mathematical operation for finding the area under the curve of a graph is called \_\_\_\_\_.
- a) differentiation
  - b) integration
  - c) curve averaging
  - d) linear regression



42. The formula  $I_C = \left[ \frac{V_C}{t} \right] C$  shows that for a given capacitor, if the voltage changes at a constant rate with respect to time, then current will:
- a) increase
  - b) decrease
  - c) be constant
  - d) decrease logarithmically
43. The output of an op-amp differentiator with a rectangular input is a:
- a) series of positive and negative spikes
  - b) sine wave
  - c) ramp voltage

**Chapter 13: Basic Op-Amp Applications**

1. Answer: a Difficulty: 2
2. Answer: b Difficulty: 2
3. Answer: a Difficulty: 2
4. Answer: b Difficulty: 2
5. Answer: b Difficulty: 2
6. Answer: d Difficulty: 2
7. Answer: d Difficulty: 2
8. Answer: c Difficulty: 2
9. Answer: b Difficulty: 2
10. Answer: a Difficulty: 2
11. Answer: c Difficulty: 2
12. Answer: c Difficulty: 3
13. Answer: d Difficulty: 3
14. Answer: c Difficulty: 2
15. Answer: a Difficulty: 2
16. Answer: c Difficulty: 3
17. Answer: b Difficulty: 2
18. Answer: a Difficulty: 2
19. Answer: b Difficulty: 2
20. Answer: d Difficulty: 2
21. Answer: d Difficulty: 3
22. Answer: d Difficulty: 2
23. Answer: d Difficulty: 2
24. Answer: a Difficulty: 2
25. Answer: c Difficulty: 2

- 26. Answer: d Difficulty: 2 Section: 1
- 27. Answer: c Difficulty: 2 Section: 1
- 28. Answer: b Difficulty: 2 Section: 1
- 29. Answer: d Difficulty: 2 Section: 1
- 30. Answer: c Difficulty: 2 Section: 1
- 31. Answer: b Difficulty: 2 Section: 1
- 32. Answer: b Difficulty: 2 Section: 1
- 33. Answer: a Difficulty: 3 Section: 1
- 34. Answer: b Difficulty: 2 Section: 1
- 35. Answer: b Difficulty: 2 Section: 2
- 36. Answer: b Difficulty: 3 Section: 2
- 37. Answer: b Difficulty: 3 Section: 2
- 38. Answer: d Difficulty: 2 Section: 2
- 39. Answer: d Difficulty: 2 Section: 3
- 40. Answer: a Difficulty: 2 Section: 3
- 41. Answer: b Difficulty: 2 Section: 3
- 42. Answer: a Difficulty: 3 Section: 3
- 43. Answer: a Difficulty: 2 Section: 3

## Chapter 14: Special-Purpose Op-Amp Circuits

### *MULTIPLE CHOICE*

1. A basic instrumentation amplifier has three op-amps.
  - a) true
  - b) false
2. One of the key characteristics of an instrumentation amplifier is its low input impedance.
  - a) true
  - b) false
3. The voltage gain of an instrumentation amplifier is set with an external resistor.
  - a) true
  - b) false
4. A basic isolation amplifier has two electrically isolated sections.
  - a) true
  - b) false
5. Most isolation amplifiers use transformer coupling for isolation.
  - a) true
  - b) false
6. OTA stands for operational transistor amplifier.
  - a) true
  - b) false
7. A log amplifier has a JFET in the feedback loop.
  - a) true
  - b) false
8. An antilog amplifier has a BJT in series with the input.
  - a) true
  - b) false
9. The main purpose of an instrumentation amplifier is to amplify common mode voltage.
  - a) true
  - b) false
10. The OTA is a voltage-to-current amplifier.
  - a) true
  - b) false
11. The OAT has a \_\_\_\_\_ input impedance and a \_\_\_\_\_ CMRR.
  - a) high, low
  - b) low, high
  - c) high, high
  - d) low, high

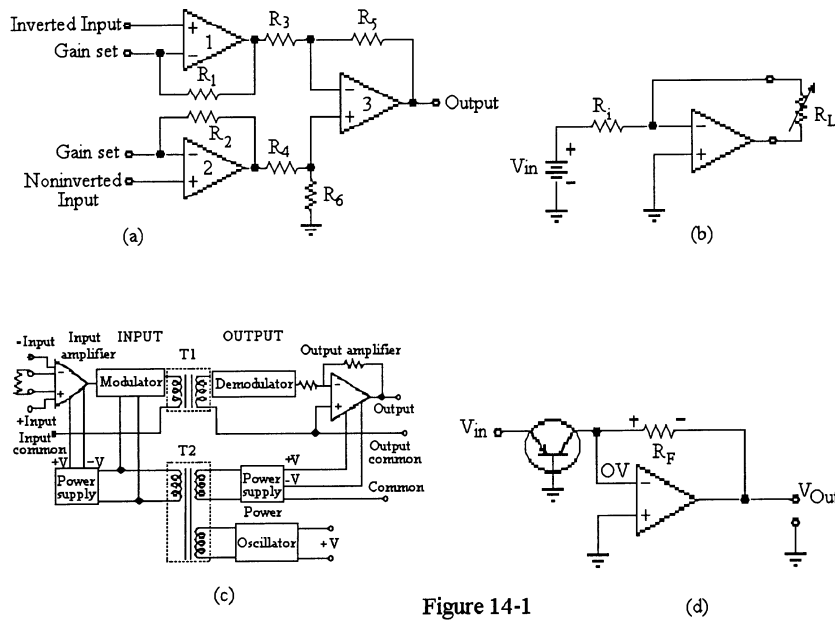

Figure 14-1

12. Refer to Figure 14-1. Which of these circuits is known as an antilog amplifier?
  - a) (a)
  - b) (b)
  - c) (c)
  - d) (d)
  
13. Refer to Figure 14-1. Which of these circuits is known as a constant-current source?
  - a) (a)
  - b) (b)
  - c) (c)
  - d) (d)
  
14. Refer to Figure 14-1. Which of these circuits is known as an isolation amplifier?
  - a) (a)
  - b) (b)
  - c) (c)
  - d) (d)
  
15. Refer to Figure 14-1. Which of these circuits is known as an instrumentation amplifier?
  - a) (a)
  - b) (b)
  - c) (c)
  - d) (d)

**Chapter 14: Special-Purpose Op-Amp Circuits**

16. Refer to Figure 14-1 (a). If  $R_1 = R_2 = 30 \text{ k}\Omega$  and the closed loop gain is 450, the value of the external gain-setting resistor  $R_G$  is:  
 a)  $133.64 \text{ k}\Omega$   
 b)  $133.64 \text{ }\Omega$   
 c)  $13.364 \text{ }\Omega$   
 d) none of the above
17. Refer to Figure 14-1 (a). If  $R_1 = R_2 = 28 \text{ k}\Omega$  and  $R_G = 100 \text{ }\Omega$ , the  $A_{C1}$  would be:  
 a) 5.51  
 b) 55.1  
 c) 551  
 d) 550
18. Refer to Figure 14-1 (b). If  $V_{in} = 5 \text{ V}$  and  $R_{in} = 22 \text{ k}\Omega$ , the current thru the load  $R_L$  would be:  
 a)  $227.27 \text{ mA}$   
 b)  $.227 \text{ }\mu\text{A}$   
 c)  $22.72 \text{ mA}$   
 d)  $227.27 \text{ }\mu\text{A}$
19. Refer to Figure 14-1 (d). If  $V_{in} = 200 \text{ mV}$ ,  $R_F = 52 \text{ k}$ , and  $I_{EBO} = 50 \text{ nA}$ , the  $V_{out}$  would be:  
 a)  $77.5 \text{ V}$   
 b)  $7.75 \text{ mV}$   
 c)  $7.75 \text{ V}$   
 d)  $775 \text{ mV}$

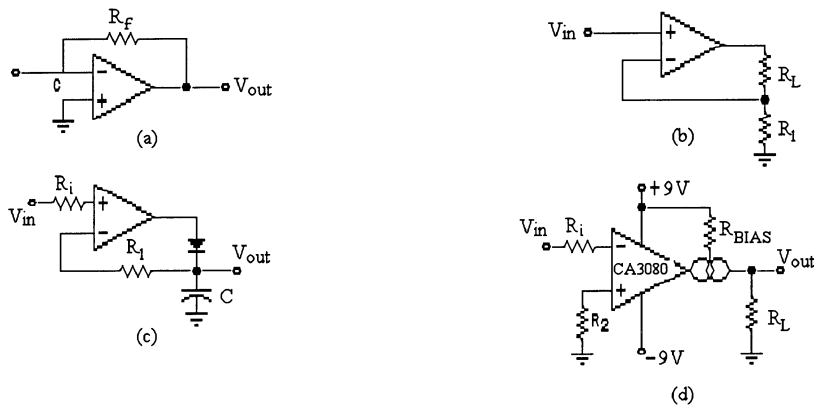

Figure 14-2

20. Refer to Figure 14-2. Which of these circuits is known as a voltage-to-current converter?  
 a) (a)  
 b) (b)  
 c) (c)  
 d) (d)

21. Refer to Figure 14-2. Which of these circuits is known as a current-to-voltage converter?  
a) (a)  
b) (b)  
c) (c)  
d) (d)
22. Refer to Figure 14-2. Which of these circuits contains an OTA?  
a) (a)  
b) (b)  
c) (c)  
d) (d)
23. Refer to Figure 14-2. Which of these circuits is known as a peak detector?  
a) (a)  
b) (b)  
c) (c)  
d) (d)
24. Refer to Figure 14-2 (b). If  $R_L = 20\text{ k}$ ,  $R_1 = 1.2\text{ k}$ , and  $V_{in} = 2.5\text{ V}$ , the load current  $I_L$  would be:  
a) 20.83 mA  
b) 2.083 mA  
c) 2.083 A  
d) 208.3  $\mu\text{A}$
25. Refer to figure 14-2 (d). If  $g_m = 25\text{ mS}$  and  $R_L = 25\text{ k}\Omega$ , the voltage gain would be:  
a) 625  
b) 62.5  
c) 6.25  
d) not enough information
26. The input signal for an instrumentation amplifier usually comes from:  
a) an inverting amplifier  
b) a transducer  
c) a differential amplifier  
d) a wheatstone bridge
27. In the classic three op-amp instrumentation amplifier, the differential voltage gain is usually produced by the:  
a) first stage  
b) second stage  
c) mismatched resistors  
d) output op amp
28. An instrumentation amplifier has a high:  
a) output impedance  
b) power gain  
c) CMRR  
d) supply voltage

## Chapter 14: Special-Purpose Op-Amp Circuits

29. An input transducer converts:
- voltage to current
  - current to voltage
  - an electrical quantity to a nonelectrical quantity
  - a nonelectrical quantity to an electrical quantity
30. In some respects an isolation amplifier is nothing more than an elaborate:
- op amp
  - instrumentation amplifier
  - rectifier and filter
  - both a and b
31. The primary function of the oscillator in an isolation amplifier is to:
- convert dc to high frequency ac
  - convert dc to low frequency ac
  - rectify high frequency ac to dc
  - produce dual polarity dc voltages for the input to the demodulator
32. The voltage gain of an OTA can be calculated using the formula:
- $A_V = \frac{R_f}{R_i}$
  - $A_V = g_m R_L$
  - $A_V = \left[ \frac{R_f}{R_i} \right] + 1$
  - $A_V = \frac{2R_f}{R_i}$
33. If an operational transconductance amplifier (OTA) is used as a nonlinear mixer and an audio signal is mixed with an RF signal, the output will be a(n) \_\_\_\_\_ signal.
- square wave
  - triangular wave
  - frequency modulated (FM)
  - amplitude modulated (AM)
34. When using an OTA in a Schmitt-trigger configuration, the trigger points are controlled by:
- the  $I_{OUT}$
  - the  $I_{BIAS}$
  - the  $V_{OUT}$
  - both a and b
35. A logarithmic characteristic, when placed in the feedback loop, will produce a natural logarithm?
- true
  - false



36. An antilog amplifier is formed by connecting a PN junction (diode or BJT) to the:
- a) input
  - b) output
  - c) feedback loop
  - d) inverting and noninverting inputs
37. To scale down large signal voltages without obscuring lower signal voltages, \_\_\_\_\_ should be used.
- a) signal compression
  - b) logarithmic signal compression
  - c) natural logarithmic signal compression
  - d) antilogarithmic signal compression
38. A voltage-to-current converter is used in applications where its necessary to have an output load current that is controlled by \_\_\_\_\_.
- a) input voltage
  - b) input resistance
  - c) output resistance
  - d) input frequency
39. The output of a peak detector is always:
- a) 70.7% of input
  - b) equal to the max value of the peak level received since the last reset pulse
  - c) equal to the min value of the peak level received since the last reset pulse
  - d) none of the above
40. The precision rectifier circuit is designed to \_\_\_\_\_.
- a) rectify precision waveforms
  - b) amplify and rectify waveforms
  - c) rectify waveforms with very small voltage swings
  - d) rectify waveforms with very large voltage swings

**Chapter 14: Special-Purpose Op-Amp Circuits**

1. Answer: a Difficulty: 2
2. Answer: b Difficulty: 2
3. Answer: a Difficulty: 2
4. Answer: b Difficulty: 2
5. Answer: a Difficulty: 2
6. Answer: b Difficulty: 2
7. Answer: b Difficulty: 2
8. Answer: a Difficulty: 2
9. Answer: b Difficulty: 2
10. Answer: a Difficulty: 2
11. Answer: c Difficulty: 2
12. Answer: d Difficulty: 2
13. Answer: b Difficulty: 2
14. Answer: c Difficulty: 2
15. Answer: a Difficulty: 2
16. Answer: b Difficulty: 2
17. Answer: c Difficulty: 2
18. Answer: d Difficulty: 2
19. Answer: c Difficulty: 2
20. Answer: b Difficulty: 2
21. Answer: a Difficulty: 2
22. Answer: d Difficulty: 2
23. Answer: c Difficulty: 2
24. Answer: b Difficulty: 2
25. Answer: a Difficulty: 2

- 26. Answer: d Difficulty: 2 Section: 1
- 27. Answer: a Difficulty: 3 Section: 1
- 28. Answer: c Difficulty: 2 Section: 1
- 29. Answer: d Difficulty: 2 Section: 1
- 30. Answer: d Difficulty: 2 Section: 2
- 31. Answer: a Difficulty: 3 Section: 2
- 32. Answer: b Difficulty: 2 Section: 2
- 33. Answer: d Difficulty: 3 Section: 2
- 34. Answer: d Difficulty: 3 Section: 2
- 35. Answer: b Difficulty: 3 Section: 4
- 36. Answer: a Difficulty: 3 Section: 4
- 37. Answer: b Difficulty: 3 Section: 4
- 38. Answer: a Difficulty: 3 Section: 5
- 39. Answer: b Difficulty: 2 Section: 5
- 40. Answer: c Difficulty: 2 Section: 5

## Chapter 15: Active Filters

### MULTIPLE CHOICE

1. The bandwidth of a band-pass filter is the difference between the two cutoff frequencies.  
a) true  
b) false
2. Butterworth filters have a roll-off of 40 dB/decade and a widely varying output in the pass-band.  
a) true  
b) false
3. A high-pass filter passes high frequencies easily and attenuates all others.  
a) true  
b) false
4. A low-pass filter attenuates low frequencies.  
a) true  
b) false
5. A band-reject filter passes all frequencies above and below a band.  
a) true  
b) false

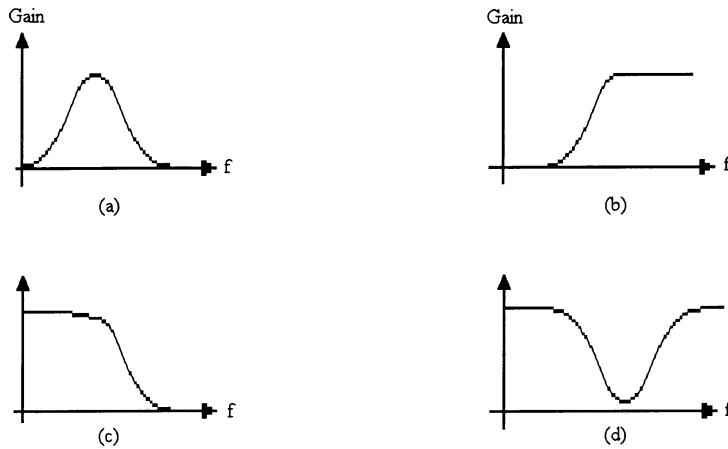

Figure 15-1

6. Refer to Figure 15-1 (a). This is the frequency response curve for a:  
a) low-pass filter  
b) high-pass filter  
c) band-pass filter  
d) band-stop filter
7. Refer to Figure 15-1 (b). This is the frequency response curve for a:  
a) low-pass filter  
b) high-pass filter  
c) band-pass filter  
d) band-stop filter

8. Refer to Figure 15-1 (c). This is the frequency response curve for a:
- low-pass filter
  - high-pass filter
  - band-pass filter
  - band-stop filter
9. Refer to Figure 15-1 (d). This is the frequency response curve for a:
- low-pass filter
  - high-pass filter
  - band-pass filter
  - band-stop filter

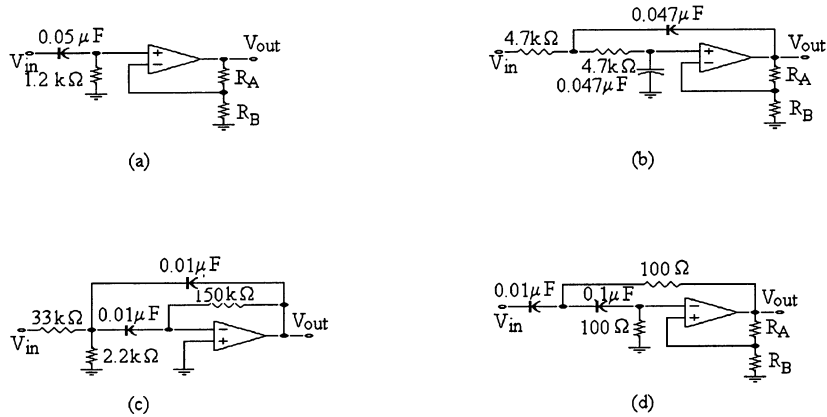

Figure 15-2

10. Refer to Figure 15-2. Identify the active single-pole high-pass filter.
- (a)
  - (b)
  - (c)
  - (d)
11. Refer to Figure 15-2. Identify the high-pass filter with a 40 dB/decade roll-off.
- (a)
  - (b)
  - (c)
  - (d)
12. Refer to Figure 15-2. The low-pass filter with a 20 dB/decade roll-off is:
- (a)
  - (b)
  - (c)
  - none of the above
13. Refer to Figure 15-2. The band-pass filter is:
- (a)
  - (b)
  - (c)
  - (d)

**Chapter 15: Active Filters**

14. Refer to Figure 15-2. The low-pass filter with a roll-off of 40 dB/decade is:
- (a)
  - (b)
  - (c)
  - (d)
15. Refer to Figure 15-2 (a). This circuit was checked for proper operation and  $f_C$  was correct but the voltage gain is 1. The cause of this problem might be:
- the 1.2 k $\Omega$  resistor is open
  - the capacitor is shorted
  - $R_A$  is open
  - $R_B$  is open

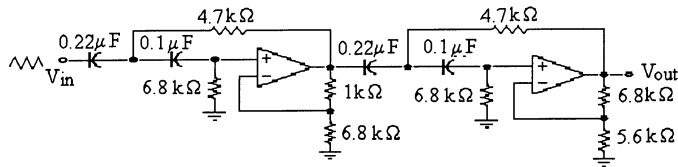

Figure 15-3

16. Refer to Figure 15-3. This circuit is known as a \_\_\_\_\_ and the roll-off rate is \_\_\_\_\_.
- low-pass filter, 60 dB/decade
  - high-pass filter, 20 dB/decade
  - high-pass filter, 80 dB/decade
  - band-pass filter, 80 dB/decade
17. Refer to Figure 15-3. The cutoff frequency for the first filter section is \_\_\_\_\_ the cutoff frequency for the second section.
- equal to
  - higher than
  - lower than
  - none of these
18. Refer to Figure 15-3. This filter has a roll-off rate of:
- 20 dB/decade
  - 40 dB/decade
  - 60 dB/decade
  - 80 dB/decade
19. A high-pass filter has a cutoff frequency of 1.23 kHz. The bandwidth of this filter is:
- 2.46 kHz
  - 1.23 kHz
  - 644 Hz
  - none of these

20. A low-pass filter with a roll-off rate of 60 dB/decade is needed. The best combination to use is:
- a) a 2-pole filter followed by another 2-pole
  - b) two single-pole filters in series
  - c) a 2-pole filter followed by a 1-pole
  - d) none of these
21. A high-pass filter has  $R = 47 \text{ k}\Omega$  and  $C = 0.002 \text{ }\mu\text{F}$ . The cutoff frequency is:
- a) 1.694 kHz
  - b) 10.6 kHz
  - c) 3.39 Hz
  - d) none of these
22. A pole is a network that contains:
- a) a resistor and a capacitor
  - b) a resistor and an inductor
  - c) a capacitor and an inductor
  - d) two resistors and one inductor
23. A maximally flat frequency response is a common name for:
- a) Chebyshev
  - b) Bessel
  - c) Butterworth
  - d) Colpitts
24. An RC circuit produces a roll-off rate of:
- a) -20 dB/decade
  - b) -6 dB/octave
  - c) -40 dB/decade
  - d) a and b
25. A low-pass filter has a cutoff frequency of 1.23 kHz. Determine the bandwidth of the filter.
- a) 2.46 kHz
  - b) 1.23 kHz
  - c) 644 Hz
  - d) not enough information given
26. Above the  $f_c$  cutoff frequency of a low-pass filter, the output voltage \_\_\_\_\_.
- a) does not change
  - b) doubles for every 1 kHz increase in frequency
  - c) increases
  - d) decreases
27. The center frequency of a bandpass filter is always equal to the:
- a) bandwidth
  - b) geometric average of the cutoff frequencies
  - c) bandwidth divided by Q
  - d) 3-dB frequency

**Chapter 15: Active Filters**

28. Bandpass filters are designed to pass a band of frequencies between \_\_\_\_\_.
- a)  $f_{c1}$  and  $f_{c2}$
  - b) a bandstart and bandstop
  - c) 1 kHz and 10 kHz
  - d) 1 kHz and 10 MHz
29. Low-Q filters are \_\_\_\_\_ circuits, and high-Q filters are \_\_\_\_\_ circuits.
- a) bandpass, bandstop
  - b) wide bandpass, narrow bandpass
  - c) low pass, high pass
  - d) low order, high order
30. A notch filter is a(n):
- a) all-pass filter
  - b) bandpass circuit
  - c) bandstop circuit
  - d) time-delay circuit
31. The type of filter response with a rippled passband is the:
- a) Butterworth
  - b) Chebyshev
  - c) Inverse Chebyshev
  - d) Bessel
32. The approximation that distorts digital signals the least is the:
- a) Butterworth
  - b) Chebyshev
  - c) Elliptic
  - d) Bessel
33. The filter with the slowest roll-off rate is the:
- a) Butterworth
  - b) Chebyshev
  - c) Elliptic
  - d) Bessel
34. The damping factor (DF) of an active filter determined by:
- a) the positive feedback of the circuit
  - b) the negative feedback of the circuit
  - c) the number of poles
  - d) the Q of the circuit
35. If a Butterworth filter has 9 second-order stages, its rolloff rate is:
- a) 20 dB per decade
  - b) 40 dB per decade
  - c) 180 dB per decade
  - d) 360 dB per decade



36. Sallen-Key filters are also called:
- a) VCVS filters
  - b) multiple feedback filters
  - c) biquadratic filters
  - d) state-variable filters
37. By cascading low-pass filters, \_\_\_\_\_ can be improved.
- a) band-width
  - b) roll-off rate
  - c) Q-rating
  - d) phase shift
38. A multiple-feedback bandpass filter \_\_\_\_\_.
- a) uses a minimum of two op amps
  - b) is used for a narrow band (high Q) filter
  - c) is used for a wide band (low Q) filter
  - d) is also known as a Sallen-Key filter
39. The state-variable filter:
- a) is difficult to tune
  - b) uses fewer than three op amps
  - c) has high component sensitivity
  - d) has a low-pass, high-pass and bandpass output
40. The Q of a state-variable filter is controlled by the:
- a) ratio of  $\frac{R_5}{R_6}$
  - b) product of  $R_5 \times R_6$
  - c) ratio of the feedback resistors
  - d) both a and c
41. How does the multiple-feedback bandstop filter differ from the multiple-feedback bandpass filter?
- a) both the inverting and noninverting inputs use feedback and input resistors
  - b) both have input and feedback capacitors
  - c) both inverting and noninverting inputs have ac applied
  - d) both a and b

## **Chapter 15: Active Filters**

1. Answer: a Difficulty: 2
2. Answer: b Difficulty: 2
3. Answer: a Difficulty: 2
4. Answer: b Difficulty: 2
5. Answer: a Difficulty: 2
6. Answer: c Difficulty: 2
7. Answer: b Difficulty: 2
8. Answer: a Difficulty: 2
9. Answer: d Difficulty: 2
10. Answer: a Difficulty: 2
11. Answer: d Difficulty: 2
12. Answer: d Difficulty: 2
13. Answer: c Difficulty: 2
14. Answer: b Difficulty: 2
15. Answer: d Difficulty: 3
16. Answer: c Difficulty: 3
17. Answer: a Difficulty: 2
18. Answer: b Difficulty: 2
19. Answer: d Difficulty: 2
20. Answer: c Difficulty: 2
21. Answer: a Difficulty: 2
22. Answer: a Difficulty: 2
23. Answer: c Difficulty: 2
24. Answer: d Difficulty: 3
25. Answer: b Difficulty: 3

- 26. Answer: d Difficulty: 3 Section: 1
- 27. Answer: b Difficulty: 1 Section: 1
- 28. Answer: a Difficulty: 2 Section: 1
- 29. Answer: b Difficulty: 2 Section: 1
- 30. Answer: c Difficulty: 2 Section: 1
- 31. Answer: b Difficulty: 2 Section: 2
- 32. Answer: b Difficulty: 3 Section: 2
- 33. Answer: a Difficulty: 2 Section: 2
- 34. Answer: b Difficulty: 2 Section: 2
- 35. Answer: d Difficulty: 1 Section: 2
- 36. Answer: a Difficulty: 2 Section: 4
- 37. Answer: b Difficulty: 2 Section: 3
- 38. Answer: c Difficulty: 3 Section: 5
- 39. Answer: d Difficulty: 2 Section: 5
- 40. Answer: d Difficulty: 3 Section: 5
- 41. Answer: d Difficulty: 3 Section: 6

## Chapter 16: Oscillators

### MULTIPLE CHOICE

1. To operate properly, an oscillator requires an external ac input signal.
  - a) true
  - b) false
2. An oscillator can produce many types of outputs, such as sine, triangle, or square waves.
  - a) true
  - b) false
3. Positive feedback is required for an oscillator to operate properly.
  - a) true
  - b) false
4. Crystal oscillators are very stable.
  - a) true
  - b) false
5. An RC phase-shift oscillator uses feedback from a tank circuit.
  - a) true
  - b) false

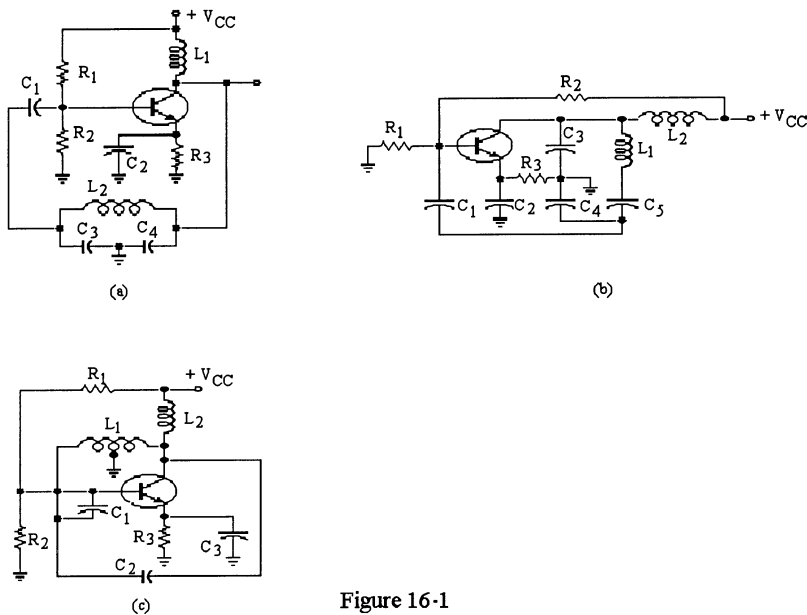
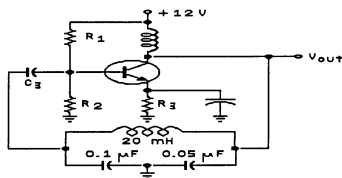

Figure 16-1

6. Refer to Figure 16-1. Which of these circuits is known as a Clapp oscillator?
  - a) (a)
  - b) (b)
  - c) (c)
  - d) none of these

7. Refer to Figure 16-1. Which of these circuits is known as a crystal oscillator?
  - a) (a)
  - b) (b)
  - c) (c)
  - d) none of these
8. Refer to Figure 16-1. Which of these circuits is known as an Armstrong oscillator?
  - a) (a)
  - b) (b)
  - c) (c)
  - d) none of these
9. Refer to Figure 16-1. Which of these circuits is known as a Colpitts oscillator?
  - a) (a)
  - b) (b)
  - c) (c)
  - d) none of these
10. Refer to Figure 16-1. Which of these circuits is known as a Hartley oscillator?
  - a) (a)
  - b) (b)
  - c) (c)
  - d) none of these
11. Refer to Figure 16-1 (a). The resonant frequency is determined by:
  - a)  $L_1, C_1$
  - b)  $L_2, C_1, C_2$
  - c)  $L_1, C_3, C_4$
  - d)  $L_2, C_3, C_4$
12. Refer to Figure 16-1 (c). The main frequency determining components are:
  - a)  $L_2, C_2$ .
  - b)  $L_1, C_1$ .
  - c)  $L_1, C_2$ .
  - d)  $L_2, C_1$ .



**Figure 16-2**

**Chapter 16: Oscillators**

13. Refer to Figure 16-2. If the 20 mH inductor were increased to 100 mH, the resonant frequency would:
  - a) increase
  - b) decrease
  - c) remain the same
  - d) cannot be determined
14. Refer to Figure 16-2. This circuit operates easily as a:
  - a) variable frequency oscillator
  - b) fixed frequency oscillator
  - c) a crystal oscillator
  - d) none of these

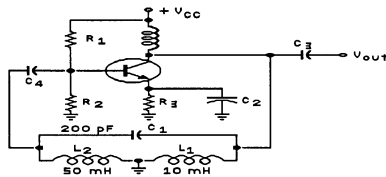

Figure 16-3

15. Refer to Figure 16-3. This circuit is known as:
  - a) a Clapp oscillator
  - b) a Colpitts oscillator
  - c) an Armstrong oscillator
  - d) a Hartley oscillator
16. Refer to Figure 16-3. This type of oscillator utilizes \_\_\_\_\_ feedback to control the oscillation. The voltage gain is \_\_\_\_\_.
  - a) negative, low
  - b) positive, high
  - c) positive, low
  - d) negative, high
17. An op-amp differentiator with a linear ramp voltage as its input, will have \_\_\_\_\_ output.
  - a) dc
  - b) a square wave
  - c) a sine wave
  - d) a triangle wave
18. A very stable oscillator is needed to operate on a single frequency, a good choice might be:
  - a) a Hartley
  - b) a Colpitts
  - c) a crystal
  - d) a Clapp

19. Refer to Figure 16-3. If  $C_1$  decreases in value, the resonant frequency will:
- increase
  - decrease
  - remain the same
  - cannot be determined

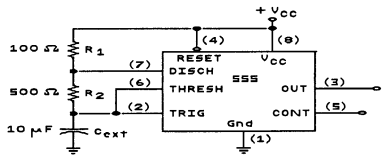

Figure 16-4

20. Refer to Figure 16-4. If the value of  $V_{CC} = 5\text{ V}$ , the output voltage would be:
- a square wave of  $10\text{ V}_{p-p}$
  - a square wave that varies between  $0\text{ V}$  and  $5\text{ V}$
  - a sine wave
  - $5\text{ V dc}$
21. Nonsinusoidal oscillators produce:
- sine waves only
  - triangle waves only
  - square waves only
  - either b or c
22. The 555 timer contains:
- 2 comparators
  - 3 comparators
  - 4 comparators
  - 5 comparators
23. The most stable type of oscillator is:
- the Clapp oscillator
  - the Hartley oscillator
  - the Crystal oscillator
  - the Colpitts oscillator
24. Refer to Figure 16-4. To reduce the duty cycle to less than 50%, the following circuit change would be necessary:
- reduce the size of  $R_1$
  - reduce the size of  $R_2$
  - increase the size of  $R_1$
  - connect a diode in parallel with  $R_1$
25. A circuit that can change the frequency of oscillation with an application of a dc voltage is sometimes called:
- a voltage-controlled oscillator
  - a crystal oscillator
  - a Hartley oscillator
  - an astable multivibrator

**Chapter 16: Oscillators**

26. Which of the following is not an essential requirement of a feedback oscillator?
- a) Positive feedback network
  - b) Negative feedback network
  - c) Phase shift around the feedback loop of  $0^\circ$
  - d) Amplifier circuit
27. In order to sustain oscillations in a feedback oscillator, the gain should be \_\_\_\_\_ so the product of  $A_V \times B$  equals \_\_\_\_\_.
- a) reduced, one
  - b) reduced, less than one
  - c) increased, more than one
  - d) increased, much greater than one
28. The voltage that starts a feedback oscillator is caused by:
- a) ripple from the power supply
  - b) thermal noise in resistors
  - c) the input signal from a generator
  - d) positive feedback
29. A Wien-bridge oscillator uses:
- a) positive feedback
  - b) negative feedback
  - c) both types of feedback
  - d) an LC tank circuit
30. The RC feedback network used in the Wein-bridge oscillator has a maximum output voltage when:
- a)  $X_C = X_L$
  - b)  $X_L = R$
  - c)  $R_1 = R_2$  and  $X_{C1} = X_{C2}$
  - d)  $R = 0 \Omega$
31. The closed-loop voltage gain,  $A_{CL}$ , for a Wien-bridge oscillator is:
- a) 3, after the oscillations have built up
  - b) slightly greater than 1
  - c) less than 1
  - d) exactly 1
32. In order for feedback oscillators to have any practical value, the gain has to be:
- a) 1/4
  - b) self-adjusting
  - c) stabilized
  - d) non-linear
33. The phase-shift oscillator usually has:
- a) two lead or lag circuits
  - b) three lead or lag circuits
  - c) a lead-lag circuit
  - d) a twin-T filter



34. The Twin-T Oscillator is a popular choice because it works well over a wide range of frequencies.
- a) true
  - b) false
35. A sure way to recognize a Colpitts oscillator is by:
- a) the tapped inductors in the tank circuit
  - b) the tapped capacitors in the tank circuit
  - c) the three lag networks in the feedback path
  - d) the lead/lag network in the feedback path
36. A sure way to recognize a Hartley oscillator is by the:
- a) transformer used for feedback
  - b) three lead networks in the feedback path
  - c) tapped capacitors in the tank circuit
  - d) tapped inductors in the tank circuit
37. When Q decreases in a Colpitts oscillator, the frequency of oscillation:
- a) decreases
  - b) remains the same
  - c) increases
  - d) becomes erratic
38. The Hartley oscillator uses:
- a) negative feedback
  - b) two inductors
  - c) a tungsten lamp
  - d) a tickler coil
39. Of the following, the one with the most stable frequency is the:
- a) Armstrong
  - b) Clapp
  - c) Colpitts
  - d) Hartley
40. Which type of LC oscillator uses a tickler coil in the feedback path?
- a) Colpitts
  - b) Hartley
  - c) Armstrong
  - d) Clapp
41. Which of the following LC oscillators is least affected by the transistor and stray capacitances?
- a) Twin-T oscillator
  - b) Hartley oscillator
  - c) Colpitts oscillator
  - d) Clapp oscillator
42. In a Colpitts oscillator, which component(s) determine the feedback fraction, B?
- a) The resistors  $R_1$  and  $R_2$  in the base circuit
  - b) The RF choke in the collector circuit
  - c) The capacitors  $C_1$  and  $C_2$  in the tank circuit
  - d) The inductor in the tank circuit

**Chapter 16: Oscillators**

43. The Q of a crystal:
- a) is extremely low
  - b) is about 10 or so in most cases
  - c) is extremely high
  - d) none of the above
44. For a crystal, the series resonant frequency, and the parallel resonant frequency, are:
- a) very far apart
  - b) usually within 1 kHz
  - c) usually 10 MHz apart from each other
  - d) exactly the same
45. The higher resonant frequencies of a crystal are called:
- a) undertones
  - b) overtones
  - c) octaves
  - d) decades

1. Answer: b Difficulty: 2
2. Answer: a Difficulty: 2
3. Answer: a Difficulty: 2
4. Answer: a Difficulty: 2
5. Answer: b Difficulty: 2
6. Answer: b Difficulty: 2
7. Answer: d Difficulty: 2
8. Answer: d Difficulty: 2
9. Answer: a Difficulty: 2
10. Answer: c Difficulty: 2
11. Answer: d Difficulty: 3
12. Answer: c Difficulty: 2
13. Answer: b Difficulty: 2
14. Answer: b Difficulty: 3
15. Answer: d Difficulty: 2
16. Answer: c Difficulty: 3
17. Answer: a Difficulty: 2
18. Answer: c Difficulty: 2
19. Answer: a Difficulty: 2
20. Answer: b Difficulty: 2
21. Answer: d Difficulty: 2
22. Answer: b Difficulty: 2
23. Answer: c Difficulty: 2
24. Answer: d Difficulty: 2
25. Answer: a Difficulty: 2

**Chapter 16: Oscillators**

- 26. Answer: b Difficulty: 2 Section: 1
- 27. Answer: a Difficulty: 2 Section: 1
- 28. Answer: b Difficulty: 1 Section: 2
- 29. Answer: c Difficulty: 2 Section: 3
- 30. Answer: c Difficulty: 3 Section: 3
- 31. Answer: c Difficulty: 2 Section: 3
- 32. Answer: b Difficulty: 2 Section: 2
- 33. Answer: b Difficulty: 2 Section: 3
- 34. Answer: b Difficulty: 2 Section: 3
- 35. Answer: b Difficulty: 2 Section: 4
- 36. Answer: d Difficulty: 2 Section: 4
- 37. Answer: a Difficulty: 2 Section: 4
- 38. Answer: b Difficulty: 2 Section: 4
- 39. Answer: b Difficulty: 2 Section: 4
- 40. Answer: c Difficulty: 2 Section: 4
- 41. Answer: d Difficulty: 2 Section: 4
- 42. Answer: c Difficulty: 3 Section: 4
- 43. Answer: c Difficulty: 2 Section: 4
- 44. Answer: b Difficulty: 2 Section: 4
- 45. Answer: b Difficulty: 2 Section: 4

## Chapter 17: Communications Circuits

### *MULTIPLE CHOICE*

1. Combining an audio signal with an RF carrier in a non-linear device is called \_\_\_\_\_.
  - a) neutralization
  - b) demodulation
  - c) heterodyning
  - d) modulation
2. The process of modifying a high frequency carrier by the information to be transmitted is called \_\_\_\_\_.
  - a) modulation
  - b) multiplexing
  - c) carrier transmission
  - d) discrimination
3. Mixing two signals by a nonlinear process is called \_\_\_\_\_.
  - a) sum and product frequencies
  - b) heterodyning
  - c) spectrum modulation
  - d) bandwidth discrimination
4. The outline of the peaks of the modulated carrier has the shape of the information signal, and is called the \_\_\_\_\_.
  - a) envelope
  - b) lower-side frequency
  - c) RF index
  - d) duty cycle
5. Both FM and AM are examples of which type of modulation?
  - a) Phase
  - b) Amplitude
  - c) Angle
  - d) Duty Cycle
6. Higher modulating frequencies are amplified more than the lower frequencies at the transmitting end of an FM system by a process called \_\_\_\_\_.
  - a) pre-emphasis
  - b) full duplex
  - c) de-emphasis
  - d) filtering
7. The quadrant classification of a linear multiplier indicates the number of \_\_\_\_\_ that the multiplier can handle.
  - a) input polarity combinations
  - b) output polarity combinations
  - c) transfer characteristics
  - d) scale factors

**Chapter 17: Communications Circuits**

8. What is the purpose of a balanced modulator?
  - a) To eliminate the upper sideband
  - b) To eliminate the lower sideband
  - c) To eliminate both sidebands
  - d) To eliminate the carrier
  
9. The product of two sinusoidal signals is called:
  - a) balanced modulation
  - b) lower side frequency
  - c) suppressed-carrier modulation
  - d) both a and c
  
10. Balanced modulation is used in certain types of communications such as AM broadcast systems, but is not used in single side-band systems.
  - a) true
  - b) false
  
11. If you receive an AM signal modulated by a pure sinusoidal signal in the audio frequency range, you will hear:
  - a) a single tone
  - b) static
  - c) distortion
  - d) nothing
  
12. A mixer is basically a:
  - a) frequency doubler
  - b) frequency converter
  - c) frequency demodulator
  - d) frequency modulator
  
13. A basic IF Amplifier always has:
  - a) a tuned (resonant) circuit on the input
  - b) a tuned (resonant) circuit on the output
  - c) a tuned (resonant) circuit on both the input and output
  - d) none of the above
  
14. The main difference between an FM receiver and an AM receiver is the:
  - a) method used to recover the audio signal from the modulated IF
  - b) method used to recover the audio signal from the carrier
  - c) method used to recover the audio signal from the mixer
  - d) method used to recover the audio signal from the detector
  
15. The phase detector in a PLL is followed by a low-pass filter. The low-pass filter passes the \_\_\_\_\_ and rejects all other frequencies.
  - a) input signal
  - b) feedback signal
  - c) sum of the input and feedback signals
  - d) difference of the input and feedback signals
  
16. In a PLL, to obtain lock, the signal frequency must come within the:
  - a) lock range
  - b) less than  $f_{cap}$
  - c) capture range
  - d) greater than  $f_{cap}$

17. For a PLL the capture range is:
  - a) always greater than the lock range
  - b) always the same as the lock range
  - c) usually less than the lock range
  - d) always two times the lock range
  
18. A PLL can be used as a(n):
  - a) series voltage regulator
  - b) FM demodulator
  - c) pulse width modulator
  - d) both b & c
  
19. A phase detector has:
  - a) one input signal and two output signals
  - b) two input signals and one output signal
  - c) no input signals
  - d) three output signals
  
20. The bandwidth of the low-pass filter in a PLL determines the:
  - a) capture range
  - b) lock range
  - c) free-running frequency
  - d) phase difference
  
21. Most VCO's used in PLL's operate on the principle of \_\_\_\_\_.
  - a) variable power
  - b) variable inductance
  - c) variable reactance
  - d) phase detection
  
22. If a PLL is designed to operate in the RF range and the input to the PLL is connected to an audio signal, the output will be a(n) \_\_\_\_\_ signal.
  - a) square wave
  - b) triangular wave
  - c) frequency modulated (FM)
  - d) amplitude modulated (AM)

**Chapter 17:      *Communications Circuits***

1. Answer: d Difficulty: 2 Section: 1
2. Answer: a Difficulty: 2 Section: 1
3. Answer: b Difficulty: 3 Section: 1
4. Answer: a Difficulty: 2 Section: 1
5. Answer: c Difficulty: 2 Section: 1
6. Answer: c Difficulty: 3 Section: 1
7. Answer: a Difficulty: 3 Section: 2
8. Answer: d Difficulty: 2 Section: 3
9. Answer: d Difficulty: 2 Section: 3
10. Answer: b Difficulty: 2 Section: 3
11. Answer: a Difficulty: 2 Section: 3
12. Answer: b Difficulty: 2 Section: 4
13. Answer: c Difficulty: 2 Section: 6
14. Answer: a Difficulty: 2 Section: 7
15. Answer: d Difficulty: 2 Section: 8
16. Answer: c Difficulty: 2 Section: 8
17. Answer: c Difficulty: 2 Section: 8
18. Answer: d Difficulty: 2 Section: 8
19. Answer: b Difficulty: 2 Section: 8
20. Answer: a Difficulty: 2 Section: 8
21. Answer: c Difficulty: 2 Section: 8
22. Answer: c Difficulty: 2 Section: 8



## Chapter 18: Voltage Regulators

### MULTIPLE CHOICE

- Switching regulators are very efficient.
  - true
  - false
- A Zener diode is sometimes used as a voltage regulator.
  - true
  - false
- Line regulation is the percentage change in input voltage for a given change in output voltage.
  - true
  - false
- In a shunt regulator, the control element is in series with the load.
  - true
  - false
- Most voltage regulators include some kind of protection circuitry.
  - true
  - false

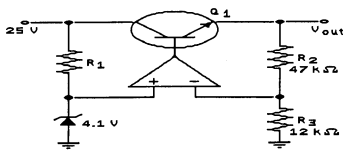

Figure 18-1(a)

- Refer to Figure 18-1 (a). If the Zener had a voltage rating of 3.7 V,  $V_{out}$  would be:
  - 25 V
  - 20.2 V
  - 18.2 V
  - 7.1 V
- Refer to Figure 18-1 (a). If a wire clipping were to short  $Q_1$  emitter to collector, the problem that might result is:
  - $R_2$  would open
  - $V_{OUT}$  would increase to 25 V
  - $Q_1$  would fail
  - the Zener would open

Chapter 18: Voltage Regulators

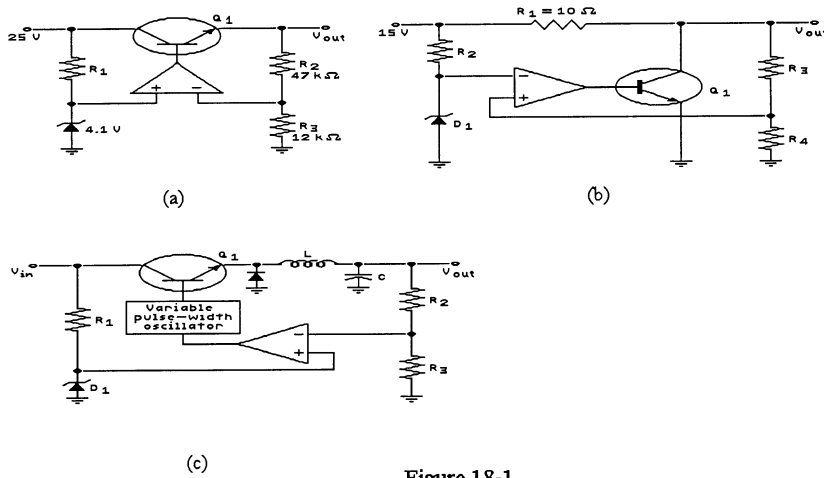

Figure 18-1

8. Refer to Figure 18-1. Which of these circuits is known as a shunt regulator?
  - a) (a)
  - b) (b)
  - c) (c)
  - d) (a) or (b)
  
9. Refer to Figure 18-1. Which of these circuits is known as a step-up switching regulator?
  - a) (a)
  - b) (b)
  - c) (c)
  - d) none of these
  
10. Refer to Figure 18-1. Which of these circuits is known as a series regulator?
  - a) (a)
  - b) (b)
  - c) (c)
  - d) none of these

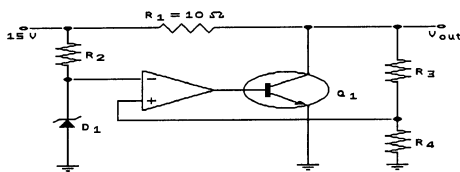

Figure 18-1(b)

11. Refer to Figure 18-1 (b). The purpose for the op-amp is:
  - a) to supply a reference voltage
  - b) to sense the error signal
  - c) to limit the input voltage to the circuit
  - d) to amplify the error signal

12. Refer to Figure 18-1 (b). An increase in  $V_{OUT}$  will cause  $Q_1$ :
- to conduct less
  - to conduct the same
  - to conduct more
  - to open

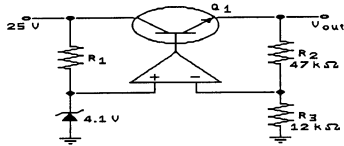

Figure 18-1(a)

13. Refer to Figure 18-1 (a). To increase the current handling capability of this regulator, beyond the 5 A rating of the transistor, the reasonable thing to do would be:
- place another transistor in series with  $Q_1$
  - increase the value of the Zener diode
  - place another transistor in parallel with  $Q_1$
  - change the values of  $R_2$  and  $R_3$

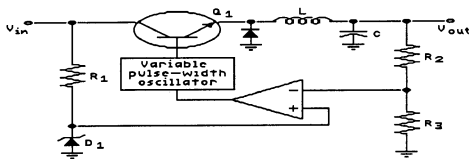

Figure 18-1(c)

14. Refer to Figure 18-1 (c). If the output voltage tends to increase due to a decrease in load current, the transistor will conduct for \_\_\_\_\_ time each cycle.
- a longer
  - a shorter
  - the same
  - exactly half the

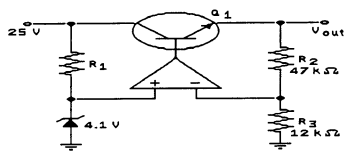

Figure 18-1(a)

15. Refer to Figure 18-1 (a). This circuit is brought in for repair. The measured output voltage was 25 V under all load conditions. A possible cause of this symptom might be:
- $R_2$  has opened
  - $Q_1$  base-emitter has opened
  - $R_3$  has opened
  - $V_{in}$  has decreased

## Chapter 18: Voltage Regulators

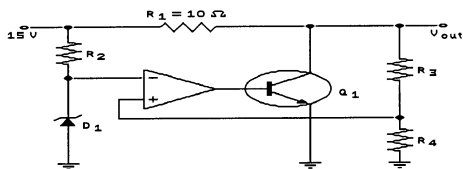
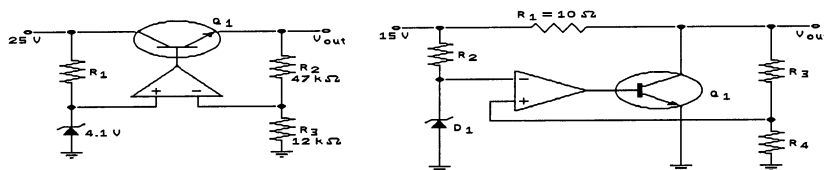

Figure 18-1(b)

16. Refer to Figure 18-1 (b). If  $R_1$  opened,  $V_{OUT}$  would:
- increase
  - decrease
  - remain the same
  - cannot be determined



(a)

(b)

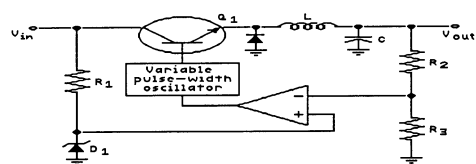

(c)

Figure 18-1

17. Refer to Figure 18-1. In all of these circuits, the Zener is used:
- to sense the change in output voltage
  - as a reference voltage
  - to supply the op-amp with  $V_{CC}$
  - to regulate the output voltage directly
18. Refer to Figure 18-1. The circuit that will also regulate the output voltage when  $V_{in}$  varies is:
- (a)
  - (b)
  - (c)
  - all of the above

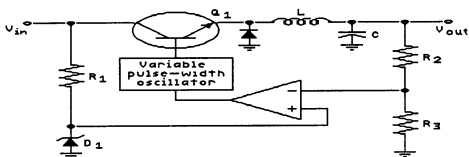

Figure 18-1(c)

19. Refer to Figure 18-1 (c). This circuit operates at a \_\_\_\_\_ frequency and its efficiency is \_\_\_\_\_.
- low, low
  - low, high
  - high, high
  - high, low

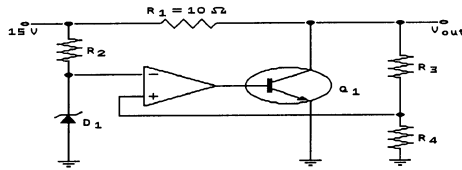

Figure 18-1(b)

20. Refer to Figure 18-1 (b). The purpose for the diode  $D_1$  is:
- to supply a reference voltage
  - to amplify the error signal
  - to sense the error signal
  - to limit the input voltage to the circuit

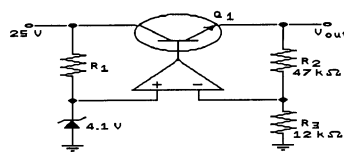

Figure 18-1(a)

21. Refer to Figure 18-1 (a). If a solder splash shorted the ends of  $R_1$  to each other, the result would be:
- the op-amp would fail
  - that  $Q_1$  would open
  - the output voltage would not change
  - the Zener would fail
22. A voltage regulator with a no-load dc output of 15 V is connected to a load with a resistance of  $12 \Omega$ . If the load voltage decreases to 14.5 V, the percent regulation would be:
- 96.7%
  - 3.33%
  - 3.45%
  - 100%
23. An advantage of a switching regulator is:
- the filter components are small
  - the circuit is very efficient
  - voltages can be stepped-up or stepped-down
  - all of these
  - none of these

## Chapter 18: Voltage Regulators

24. A voltage regulator has a no-load output of 18 V and a full load output of 17.3 V. The percent load regulation is:
- a) 0.25%
  - b) 96.1%
  - c) 4.05%
  - d) 1.04%
25. A voltage regulator with a no-load output dc voltage of 12 V is connected to a load with a resistance of 10  $\Omega$ . If the load resistance decreases to 7.5  $\Omega$ , the load voltage will decrease to 10.9 V. The load current will be \_\_\_\_\_ and the percent load regulation is \_\_\_\_\_.
- a) 1.45 A, 90.8%
  - b) 1.45 A, 9.17%
  - c) 1.6 A, 90.8%
  - d) 1.6 A, 9.17%
26. An increase of line voltage into a power supply usually produces:
- a) a decrease in load resistance
  - b) an increase in load voltage
  - c) a decrease in efficiency
  - d) less power dissipation in the rectifier diodes
27. \_\_\_\_\_ is a measurement of how well the power supply maintains a constant output voltage with changes in input voltage.
- a) voltage control
  - b) load voltage control
  - c) load regulation
  - d) line regulation
28. If the output of a voltage regulator varies from 15 to 14.7 V between the minimum and maximum load current, the load regulation is:
- a) 0
  - b) 1%
  - c) 2%
  - d) 5%
29. If the output of a voltage regulator varies from 20 to 19.8 V when the line voltage varies over its specified range, the source regulation is:
- a) 0
  - b) 1%
  - c) 2%
  - d) 5%
30. A series regulator is an example of a:
- a) linear regulator
  - b) switching regulator
  - c) shunt regulator
  - d) ac-to-dc converter
31. Without current limiting, a shorted load will probably:
- a) produce zero load current
  - b) destroy diodes and transistors
  - c) have a load voltage equal to the Zener voltage
  - d) have too little load current

32. Simple current limiting produces too much heat in the:
- a) Zener diode
  - b) load resistor
  - c) pass transistor
  - d) ambient air
33. With foldback current limiting, the load voltage approaches zero, and the load current approaches:
- a) a small value
  - b) infinity
  - c) the Zener current
  - d) a destructive level
34. If the load is shorted, the pass transistor has the least power dissipation when the regulator has:
- a) foldback limiting
  - b) low efficiency
  - c) buck topology
  - d) a high Zener voltage
35. The input current to a shunt regulator is:
- a) variable
  - b) constant
  - c) equal to load current
  - d) used to store energy in a magnetic field
36. An advantage of shunt regulation is:
- a) built-in short-circuit protection
  - b) low power dissipation in the pass transistor
  - c) high efficiency
  - d) little wasted power
37. To get more output voltage from a step-down switching regulator, you have to:
- a) decrease the duty cycle
  - b) decrease the input voltage
  - c) increase the duty cycle
  - d) increase the switching frequency
38. A \_\_\_\_\_ maintains a constant output voltage by controlling the duty cycle of a switch in series with the load.
- a) shunt regulator
  - b) linear regulator
  - c) series regulator
  - d) switching regulator
39. Switching regulators have \_\_\_\_\_ than linear regulators.
- a) longer life
  - b) simpler circuitry
  - c) a higher cost in all cases
  - d) greater efficiency

**Chapter 18: Voltage Regulators**

40. In a step-up regulator, the output voltage is filtered with a:
- a) choke-input filter
  - b) capacitor-input filter
  - c) diode
  - d) voltage divider
41. The 7800 - 12 produces a regulated output voltage of:
- a) 3 V
  - b) 4 V
  - c) 12 V
  - d) 40 V
42. The 7800 series of voltage regulators produces an output voltage that is:
- a) positive
  - b) negative
  - c) either positive or negative
  - d) unregulated
43. Shunt regulators require:
- a) shorted-load protection
  - b) load voltage sampling
  - c) high-frequency protection
  - d) open-load protection



1. Answer: a Difficulty: 2
2. Answer: a Difficulty: 2
3. Answer: b Difficulty: 2
4. Answer: b Difficulty: 2
5. Answer: a Difficulty: 2
6. Answer: c Difficulty: 2
7. Answer: b Difficulty: 3
8. Answer: b Difficulty: 2
9. Answer: d Difficulty: 2
10. Answer: a Difficulty: 2
11. Answer: d Difficulty: 2
12. Answer: c Difficulty: 3
13. Answer: c Difficulty: 2
14. Answer: b Difficulty: 2
15. Answer: a Difficulty: 3
16. Answer: b Difficulty: 2
17. Answer: b Difficulty: 2
18. Answer: a Difficulty: 2
19. Answer: c Difficulty: 2
20. Answer: a Difficulty: 2
21. Answer: d Difficulty: 3
22. Answer: c Difficulty: 2
23. Answer: d Difficulty: 2
24. Answer: c Difficulty: 2
25. Answer: b Difficulty: 2

**Chapter 18: Voltage Regulators**

- 26. Answer: b Difficulty: 2 Section: 1
- 27. Answer: d Difficulty: 2 Section: 1
- 28. Answer: c Difficulty: 2 Section: 2
- 29. Answer: b Difficulty: 2 Section: 2
- 30. Answer: a Difficulty: 2 Section: 2
- 31. Answer: b Difficulty: 2 Section: 2
- 32. Answer: c Difficulty: 2 Section: 2
- 33. Answer: a Difficulty: 3 Section: 2
- 34. Answer: a Difficulty: 2 Section: 2
- 35. Answer: b Difficulty: 2 Section: 3
- 36. Answer: a Difficulty: 2 Section: 3
- 37. Answer: c Difficulty: 3 Section: 4
- 38. Answer: d Difficulty: 2 Section: 4
- 39. Answer: d Difficulty: 2 Section: 4
- 40. Answer: b Difficulty: 2 Section: 4
- 41. Answer: c Difficulty: 2 Section: 5
- 42. Answer: a Difficulty: 2 Section: 4
- 43. Answer: b Difficulty: 2 Section: 3