



ENEE3102

ELECTRONICS LAB

Mohammad Jihad Al Ju'Beh

Section 1

PreLab: Experiment #2

Student Name: Sara Totah

Student ID: 1181779

13/9/2020

Fall semester 2020/2021

Experiment #2 Pre-lab: Diode Characteristic and Application:

I. DIODE CHARACTERISTICS:

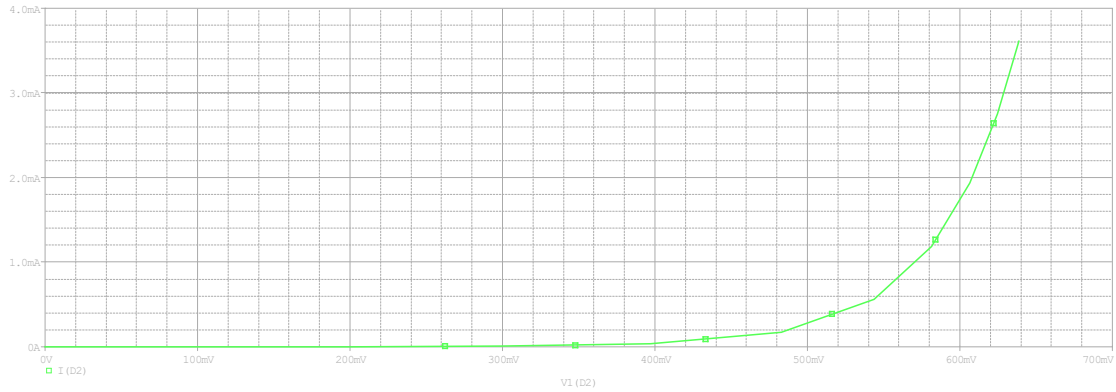
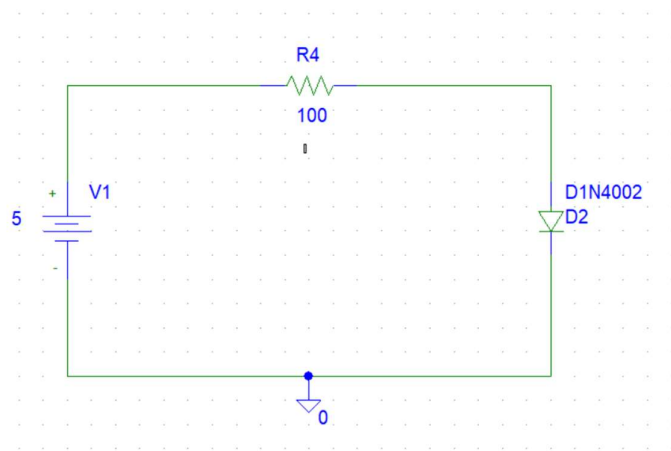

Figure 1

If we reverse the diode, the voltage on the anode will be smaller than the cathode so, there will be almost no current in the diode “open circuit”.

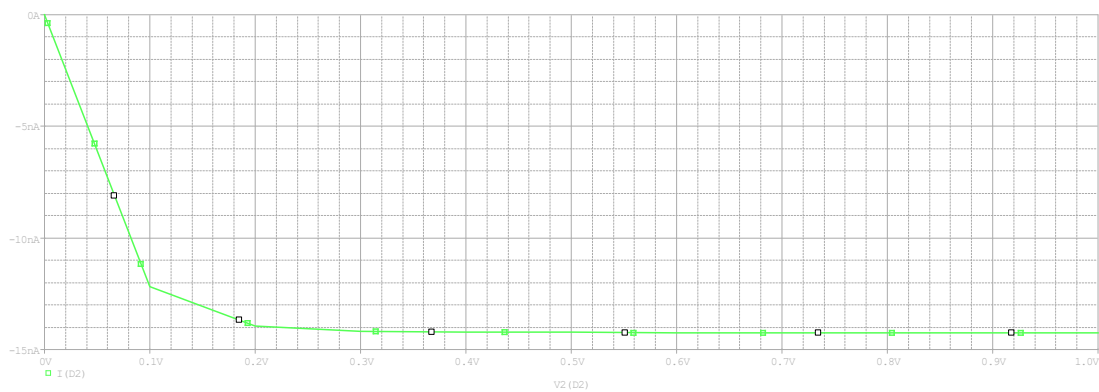

Figure 2

II. RECTIFICATION: A. HALF - WAVE RECTIFICATION:

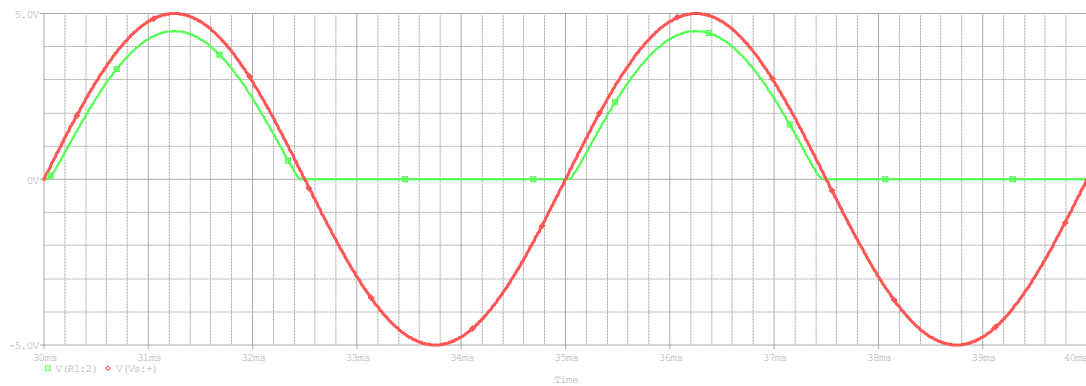
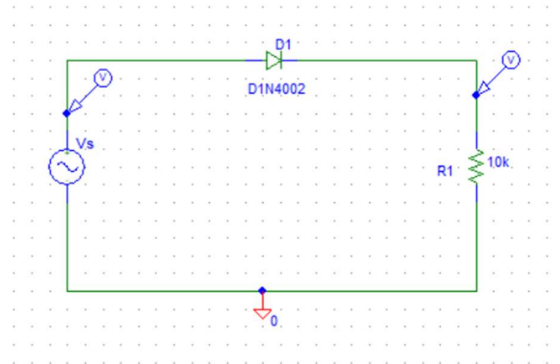

Figure 3

V_{pk} for the output voltage differs from the source peak voltage because the diode we're using isn't an ideal diode so it will cost us some losses.

If we flipped the diode "Reverse bias", the half-wave rectifier will convert the input AC signal to a negative pulsating DC signal

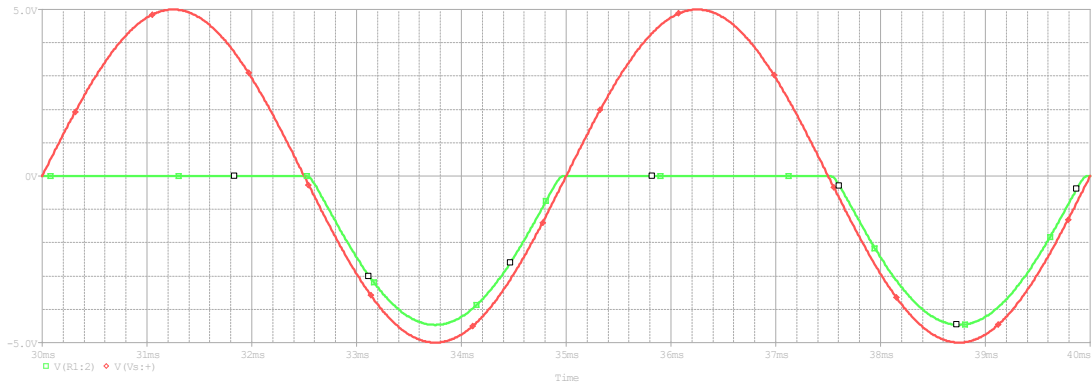

Figure 4

Adding a Filter (Capacitor) to the circuit:

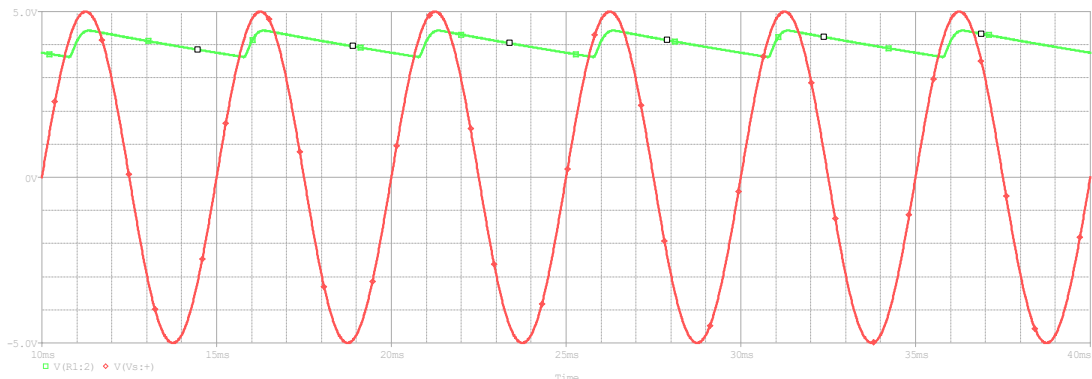
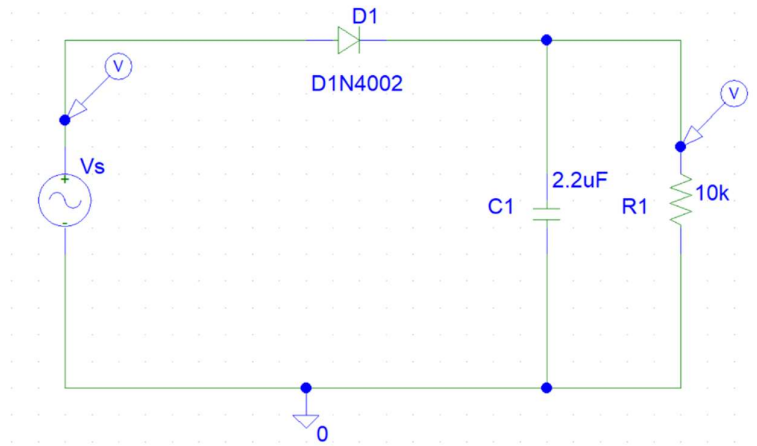
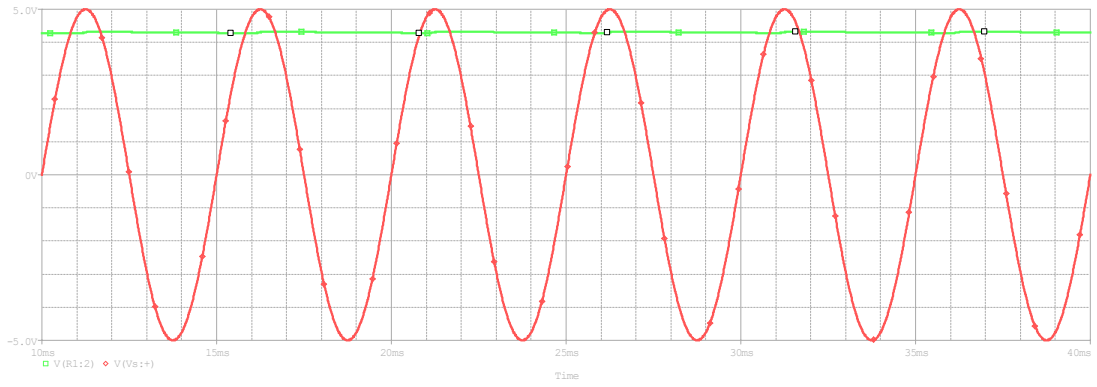
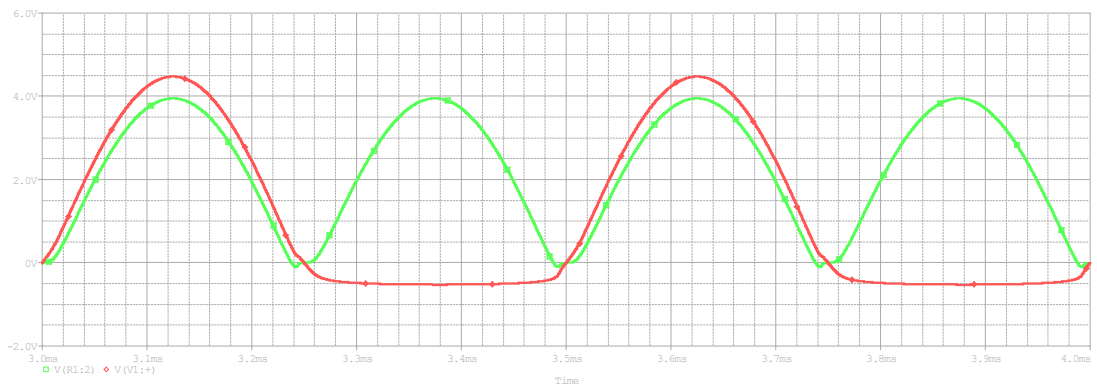
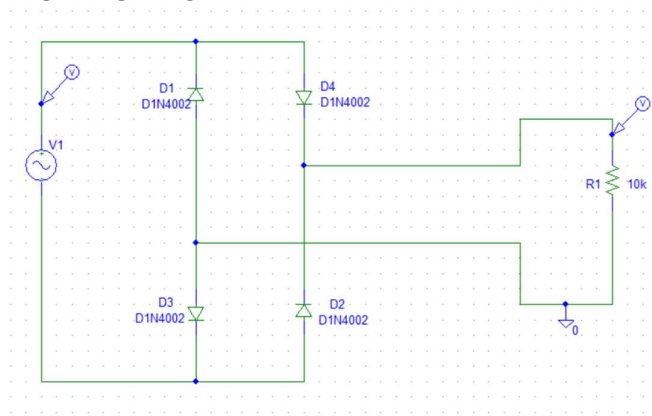

Figure 5

If we replaced the 2.2uF capacitor with 47uF capacitor, the pulsating DC will be smoother because the filter will make the ripple look like a DC component more than before.



B. FULL-WAVE RECTIFICATION:



Adding a Filter (Capacitor) to the circuit:

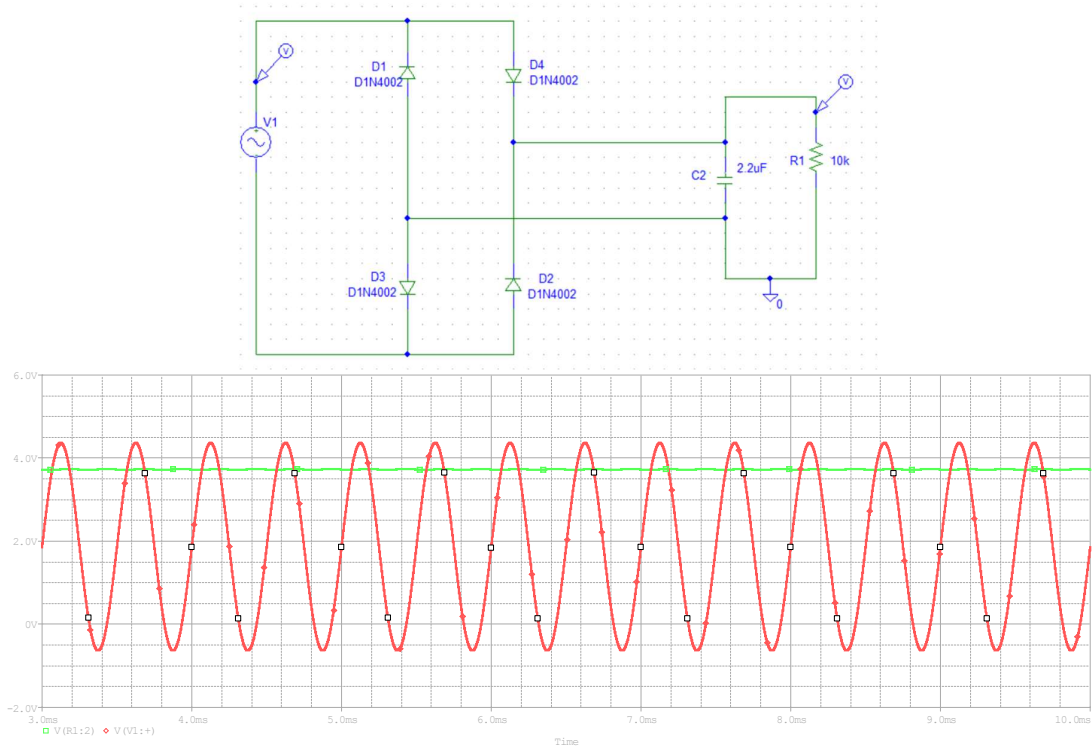

Figure 6

III. other applications:
A. clipping:

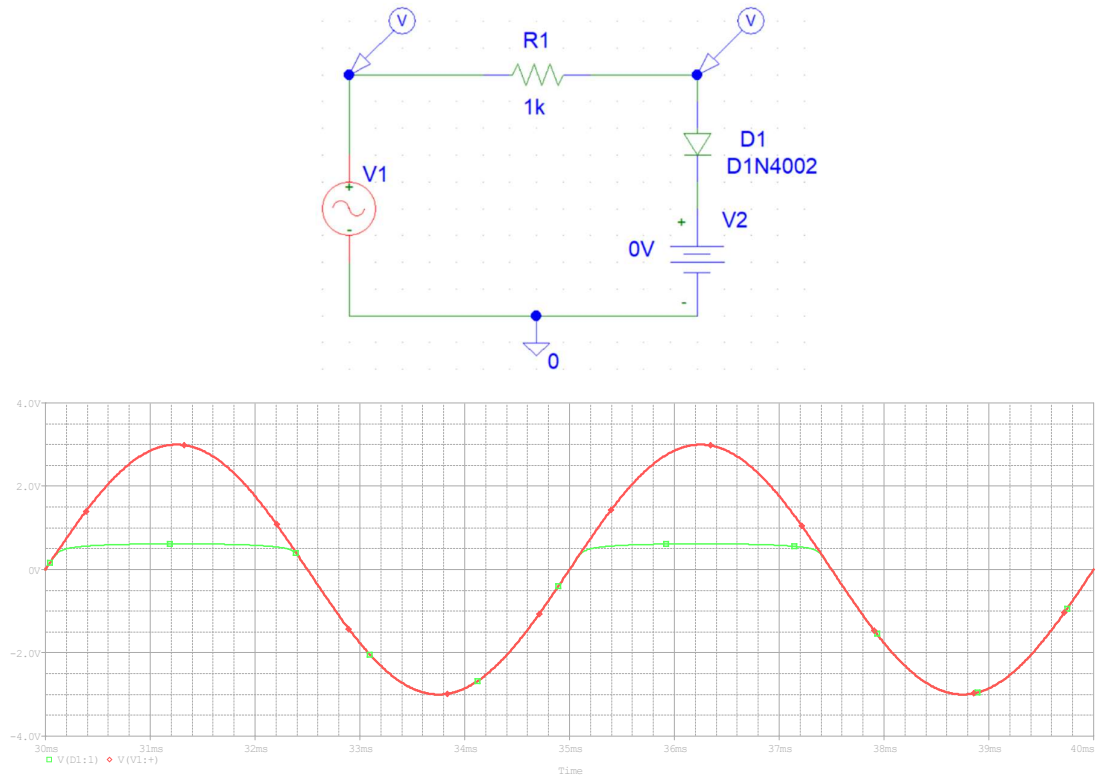

Figure 7

Changing the DC source to 2v:



Figure 8

Changing AC Vp-p to 10v:

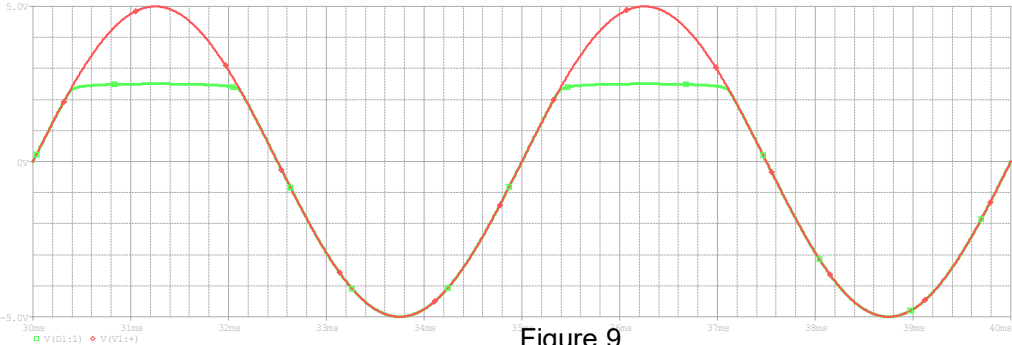
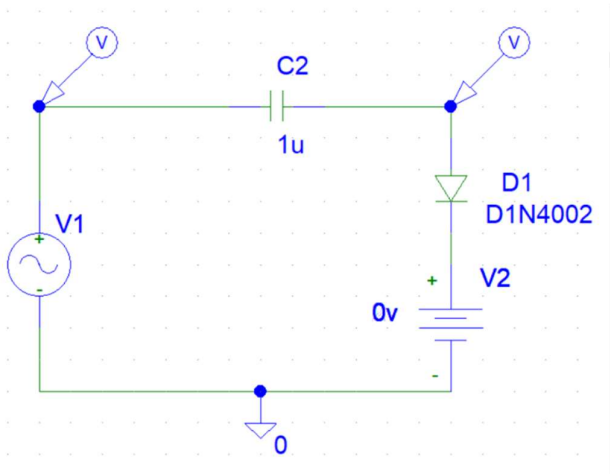

Figure 9

B. Clamping:



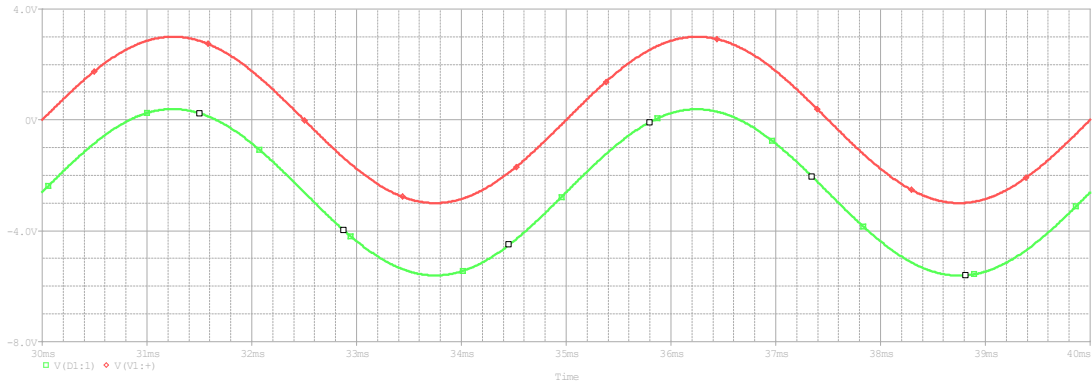

Figure 10

Changing the DC source to 2v:

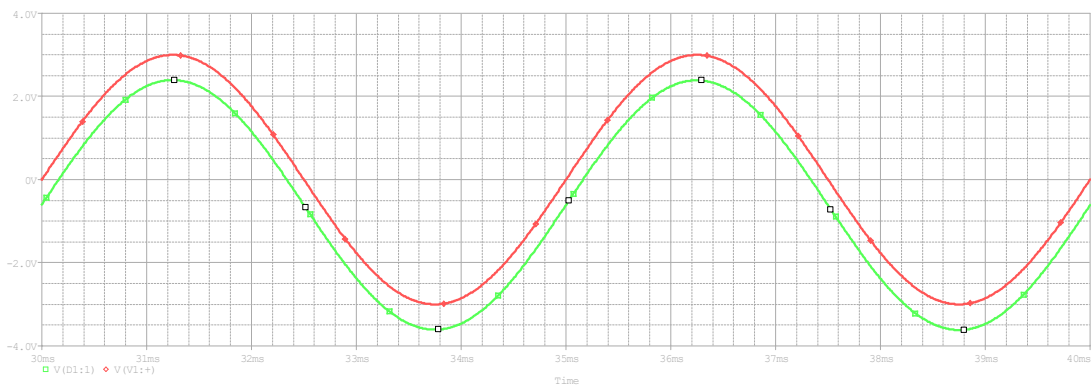

Figure 11

Changing AC Vp-p to 10v:

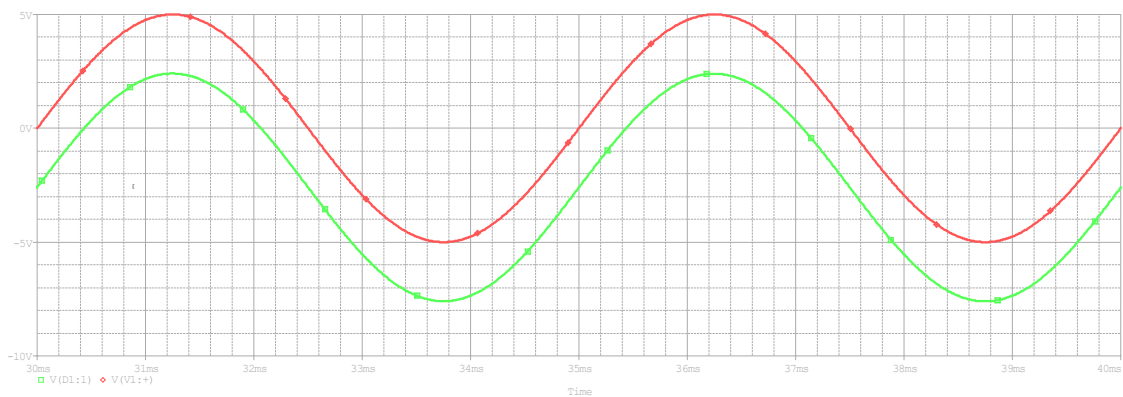

Figure 12

C. VOLTAGE MULTIPLIER CIRCUITS:

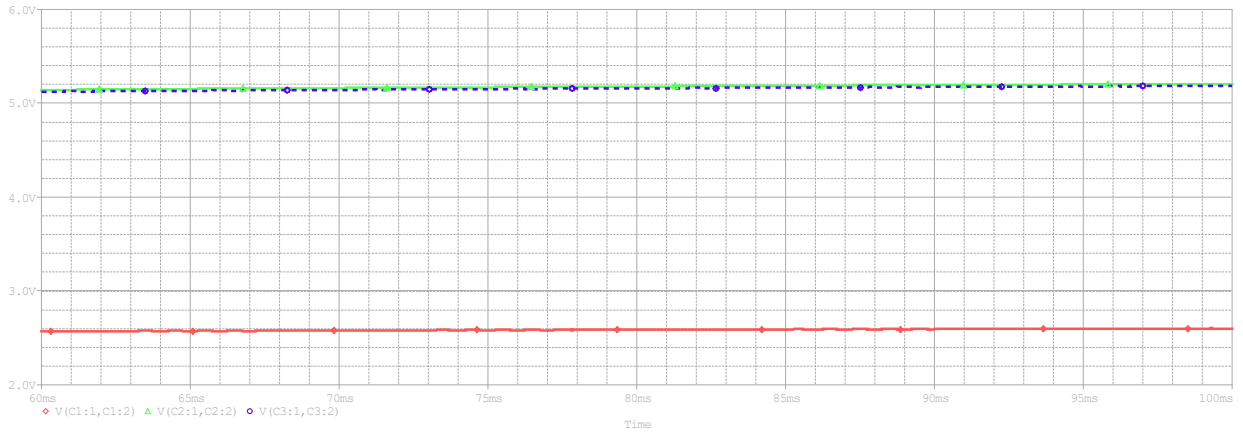
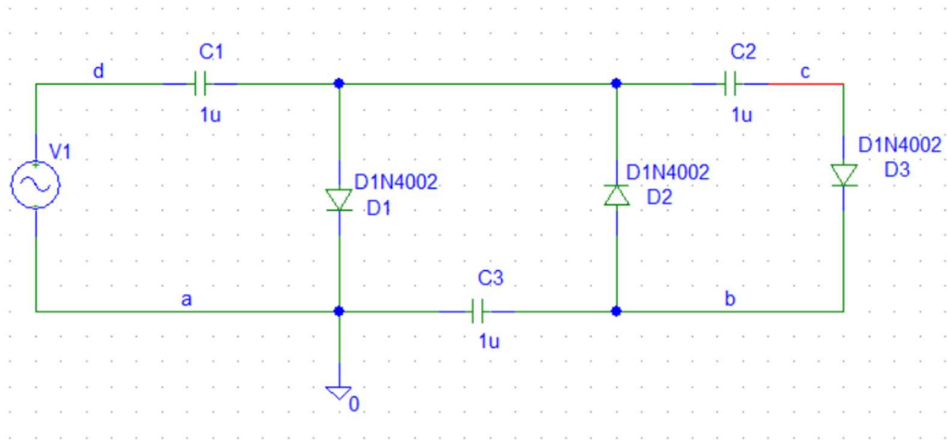

Figure 13