



# EBOOK

## Free Downloads

Downloaded From "Free Pdf E-books"

For more Free E-books Visit

<http://pdf-ebookstore.blogspot.com>

Or

Like our Facebook Fanpage

<http://www.facebook.com/pdfbooks>

NORMAN S. NISE

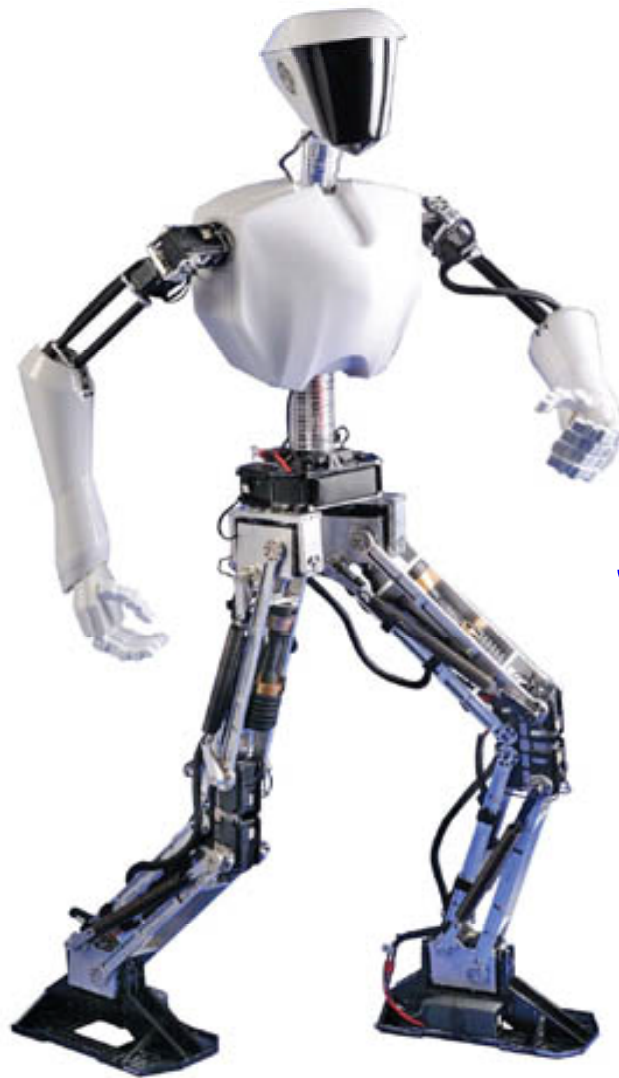

SOLUTION  
MANUAL

---

**CONTROL  
SYSTEMS  
ENGINEERING**

SIXTH EDITION

## Student companion website

Founded in 1807, John Wiley & Sons, Inc. has been a valued source of knowledge and understanding for more than 200 years, helping people around the world meet their needs and fulfill their aspirations. Our company is built on a foundation of principles that include responsibility to the communities we serve and where we live and work. In 2008, we launched a Corporate Citizenship Initiative, a global effort to address the environmental, social, economic, and ethical challenges we face in our business. Among the issues we are addressing are carbon impact, paper specifications and procurement, ethical conduct within our business and among our vendors, and community and charitable support. For more information, please visit our website: [www.wiley.com/go/citizenship](http://www.wiley.com/go/citizenship).

Copyright © 2011 by John Wiley & Sons, Inc.

No part of this publication may be reproduced, stored in a retrieval system or transmitted in any form or by any means, electronic, mechanical, photocopying recording, scanning or otherwise, except as permitted under Sections 107 or 108 of the 1976 United States Copyright Act, without either the prior written permission of the Publisher or authorization through payment of the appropriate per-copy fee to the Copyright Clearance Center, 222 Rosewood Drive, Danvers, MA 01923, (978) 750-8400, fax (978) 646-8600. Requests to the Publisher for permission should be addressed to the Permissions Department, John Wiley & Sons, Inc., 111 River Street, Hoboken, NJ 07030-5774, (201) 748-6011, fax (201) 748-6008 or online at <http://www.wiley.com/go/permissions>.

Evaluation copies are provided to qualified academics and professionals for review purposes only, for use in their courses during the next academic year. These copies are licensed and may not be sold or transferred to a third party. Upon completion of the review period, please return the evaluation copy to Wiley. Return instructions and a free of charge return shipping label are available at [www.wiley.com/go/returnlabel](http://www.wiley.com/go/returnlabel). Outside of the United States, please contact your local representative

ISBN 13 978-0470-54756-4

# O N E

## Introduction

### ANSWERS TO REVIEW QUESTIONS

1. Guided missiles, automatic gain control in radio receivers, satellite tracking antenna
2. Yes - power gain, remote control, parameter conversion; No - Expense, complexity
3. Motor, low pass filter, inertia supported between two bearings
4. Closed-loop systems compensate for disturbances by measuring the response, comparing it to the input response (the desired output), and then correcting the output response.
5. Under the condition that the feedback element is other than unity
6. Actuating signal
7. Multiple subsystems can time share the controller. Any adjustments to the controller can be implemented with simply software changes.
8. Stability, transient response, and steady-state error
9. Steady-state, transient
10. It follows a growing transient response until the steady-state response is no longer visible. The system will either destroy itself, reach an equilibrium state because of saturation in driving amplifiers, or hit limit stops.
11. Natural response
12. Determine the transient response performance of the system.
13. Determine system parameters to meet the transient response specifications for the system.
14. True
15. Transfer function, state-space, differential equations
16. Transfer function - the Laplace transform of the differential equation  
State-space - representation of an nth order differential equation as n simultaneous first-order differential equations  
Differential equation - Modeling a system with its differential equation

### SOLUTIONS TO PROBLEMS

1. Five turns yields 50 v. Therefore  $K = \frac{50 \text{ volts}}{5 \times 2\pi \text{ rad}} = 1.59$



2.

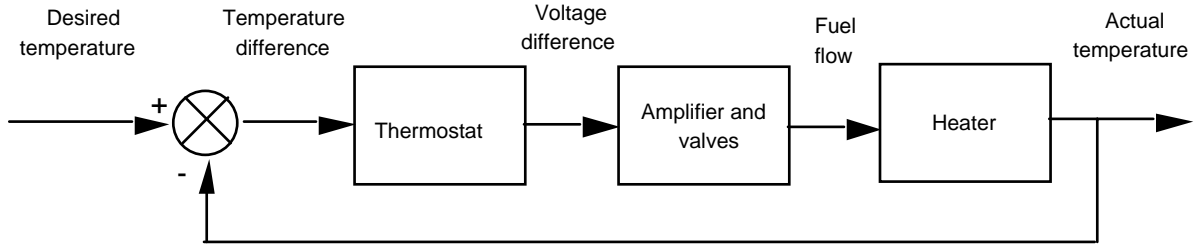

3.

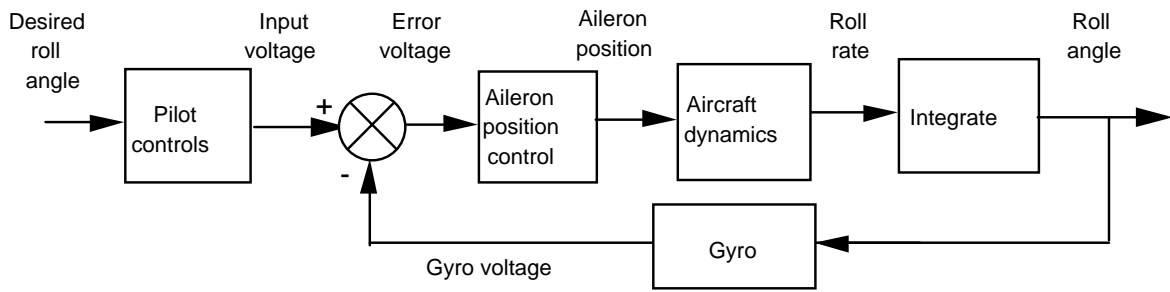

4.

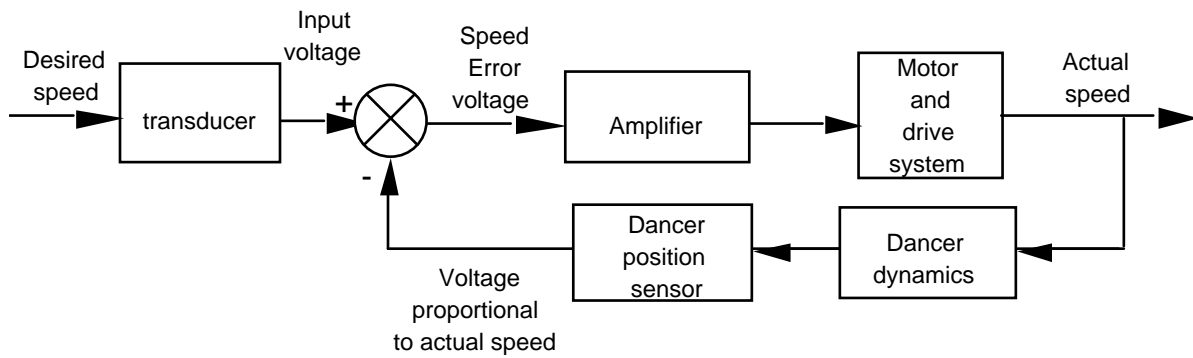

5.

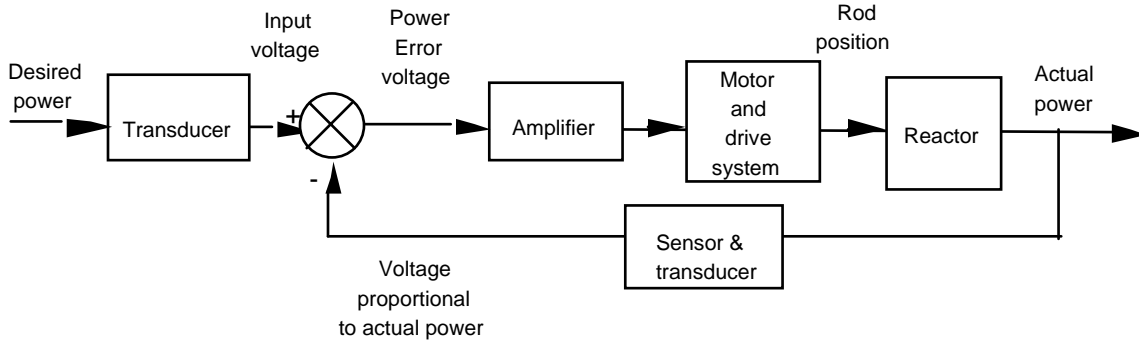

6.

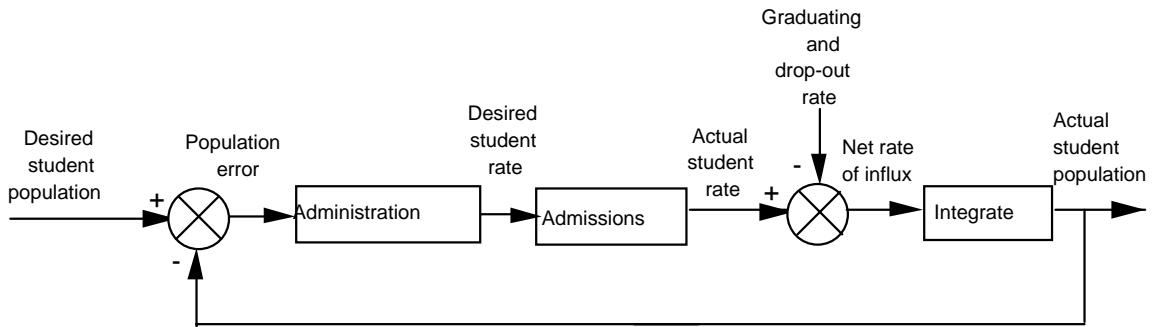

7.

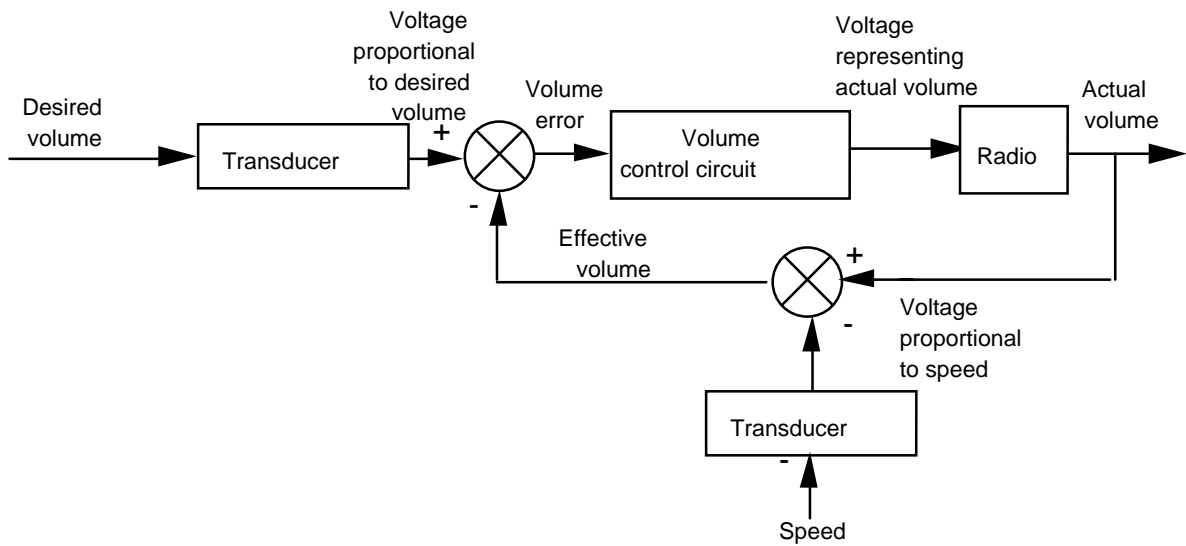

8.

a.

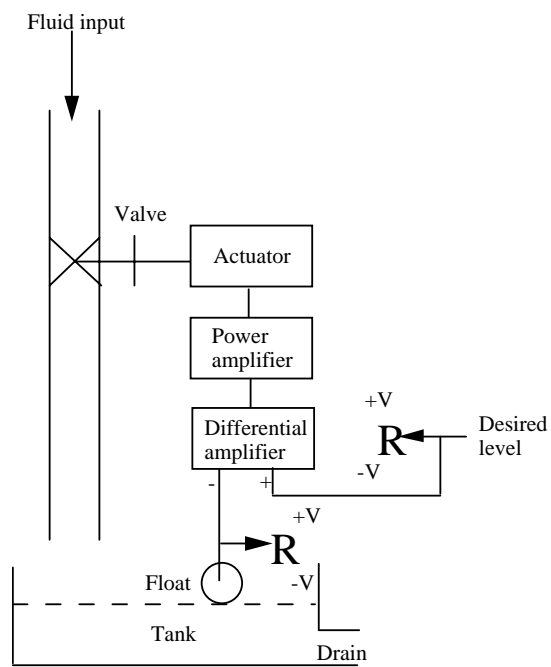

b.

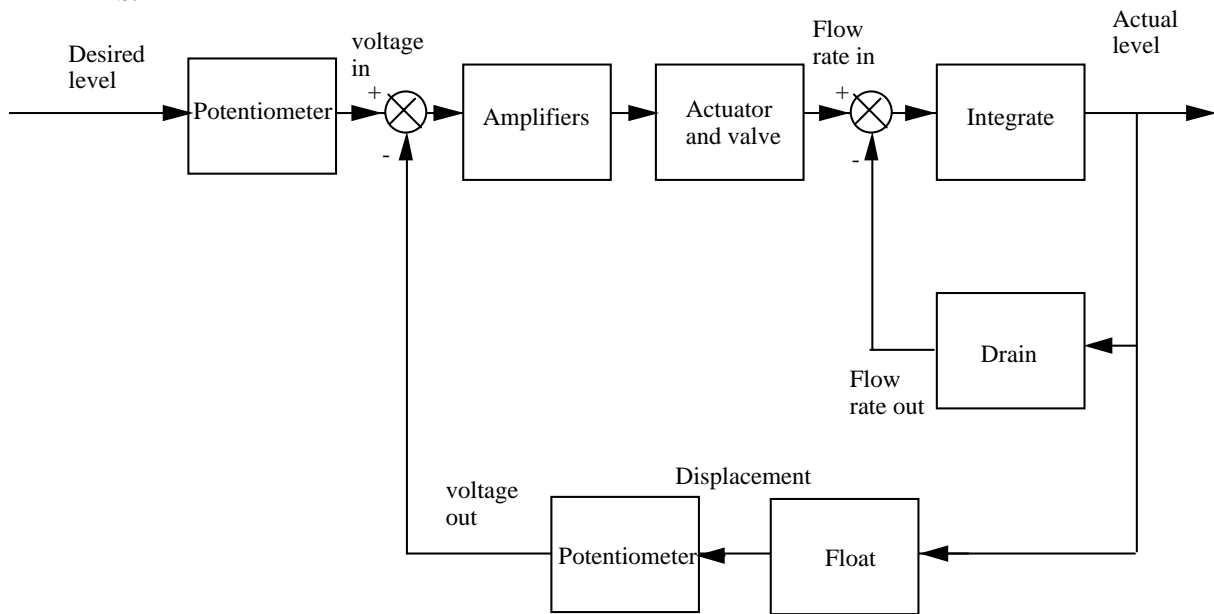

9.

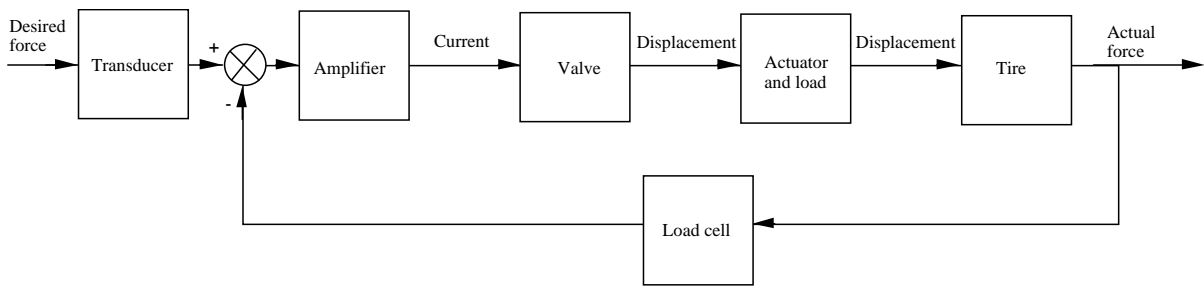

10.

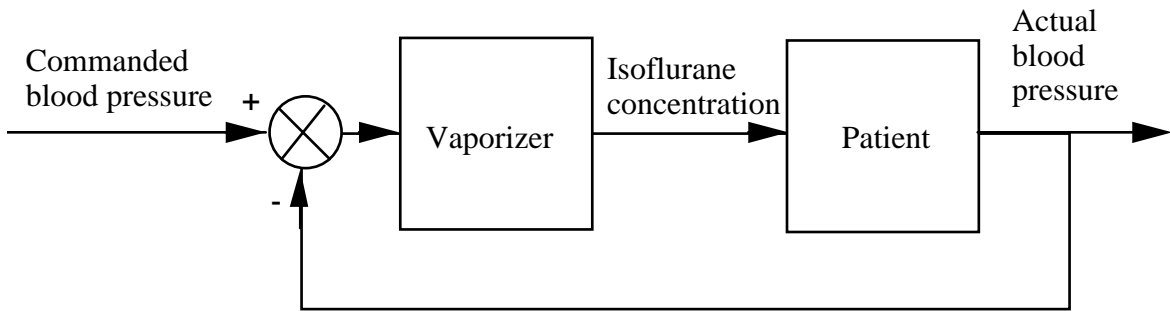

11.

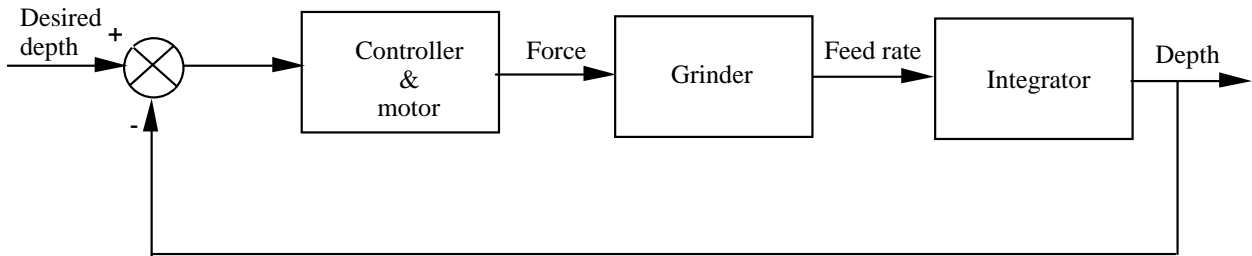

12.

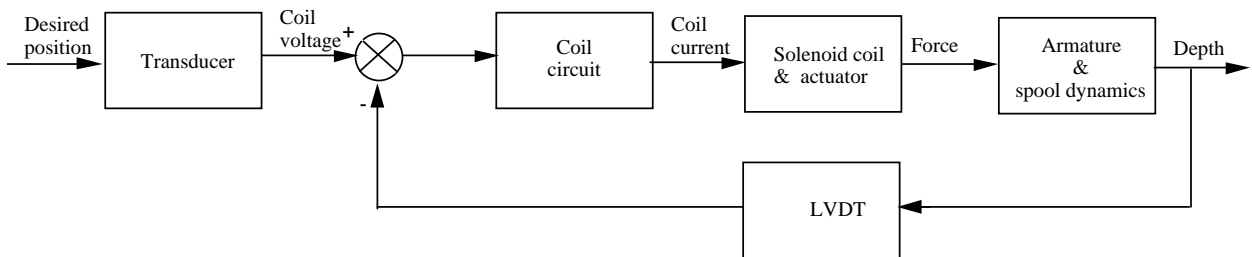

13.

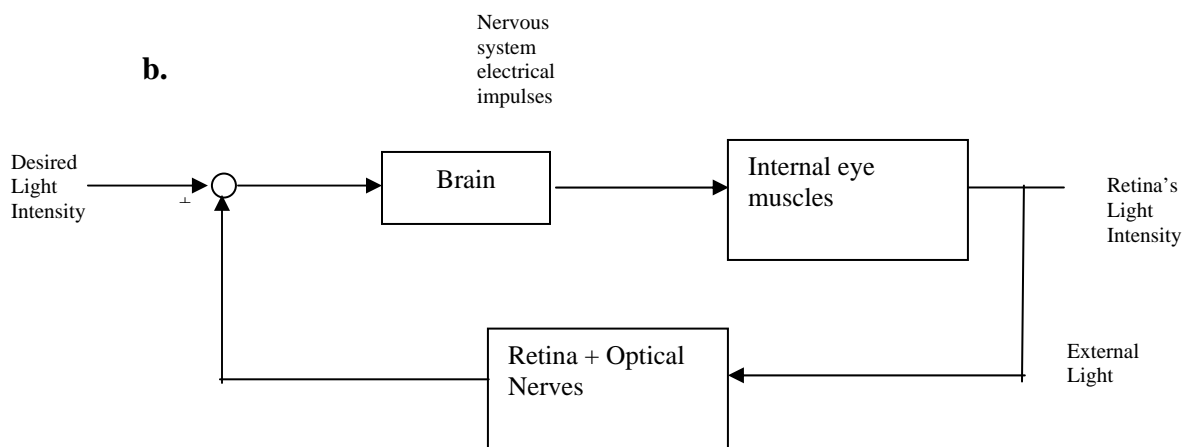
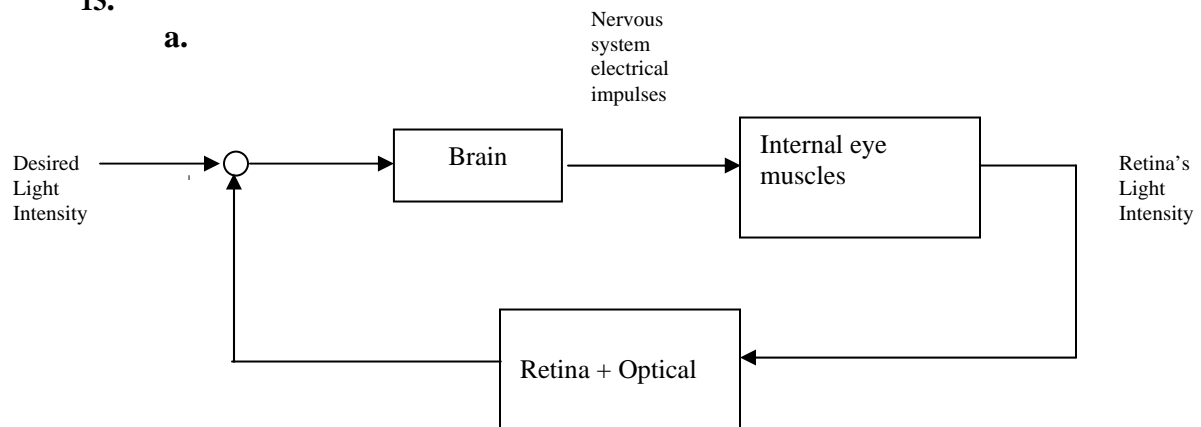

If the narrow light beam is modulated sinusoidally the pupil's diameter will also vary sinusoidally (with a delay see part c) in problem)

- c. If the pupil responded with no time delay the pupil would contract only to the point where a small amount of light goes in. Then the pupil would stop contracting and would remain with a fixed diameter.

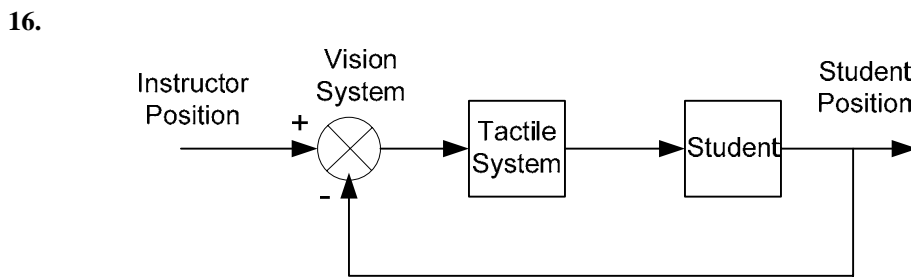
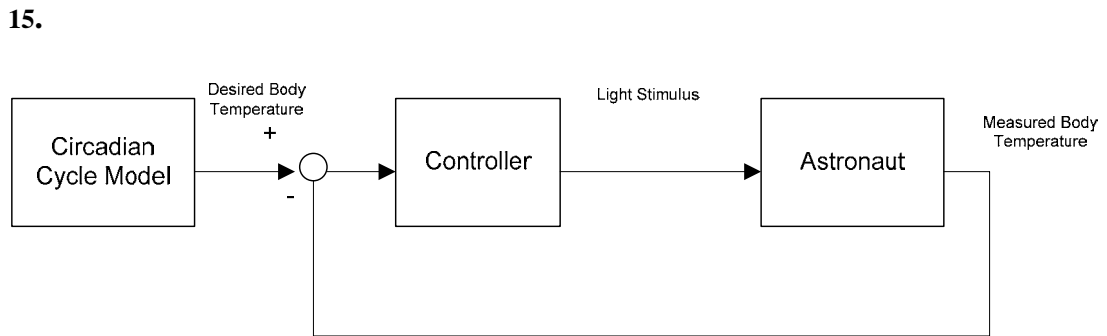
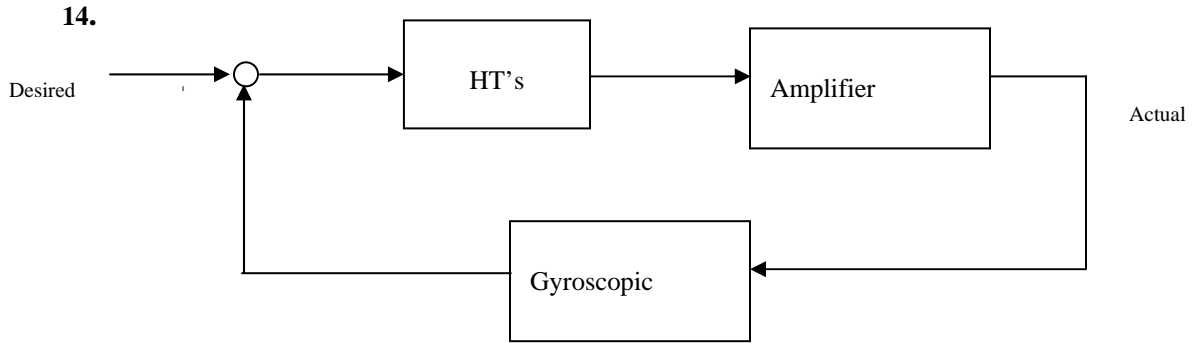

17.

a.  $L \frac{di}{dt} + Ri = u(t)$

b. Assume a steady-state solution  $i_{ss} = B$ . Substituting this into the differential equation yields  $RB =$

1,

from which  $B = \frac{1}{R}$ . The characteristic equation is  $LM + R = 0$ , from which  $M = -\frac{R}{L}$ . Thus, the total

solution is  $i(t) = Ae^{-(R/L)t} + \frac{1}{R}$ . Solving for the arbitrary constants,  $i(0) = A + \frac{1}{R} = 0$ . Thus,  $A = -\frac{1}{R}$ . The final solution is  $i(t) = \frac{1}{R} - \frac{1}{R}e^{-(R/L)t} = \frac{1}{R}(1 - e^{-(R/L)t})$ .

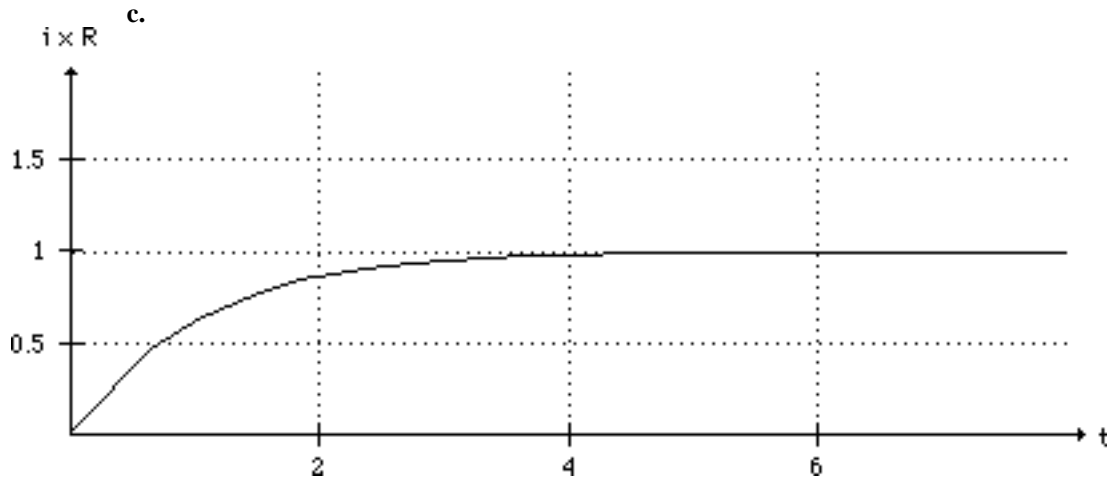

18.

a. Writing the loop equation,  $Ri + L\frac{di}{dt} + \frac{1}{C}\int idt + v_c(0) = v(t)$

b. Differentiating and substituting values,  $\frac{d^2i}{dt^2} + 2\frac{di}{dt} + 25i = 0$

Writing the characteristic equation and factoring,

$$M^2 + 2M + 25 = (M + 1 + \sqrt{24}i)(M + 1 - \sqrt{24}i).$$

The general form of the solution and its derivative is

$$i = Ae^{-t} \cos(\sqrt{24}t) + Be^{-t} \sin(\sqrt{24}t)$$

$$\frac{di}{dt} = (-A + \sqrt{24}B)e^{-t} \cos(\sqrt{24}t) - (\sqrt{24}A + B)e^{-t} \sin(\sqrt{24}t)$$

Using  $i(0) = 0$ ;  $\frac{di}{dt}(0) = \frac{v_L(0)}{L} = \frac{1}{L} = 1$

$$i(0) = A = 0$$

$$\frac{di}{dt}(0) = -A + \sqrt{24}B = 1$$

Thus,  $A = 0$  and  $B = \frac{1}{\sqrt{24}}$ .

The solution is

$$i = \frac{1}{\sqrt{24}}e^{-t} \sin(\sqrt{24}t)$$

c.

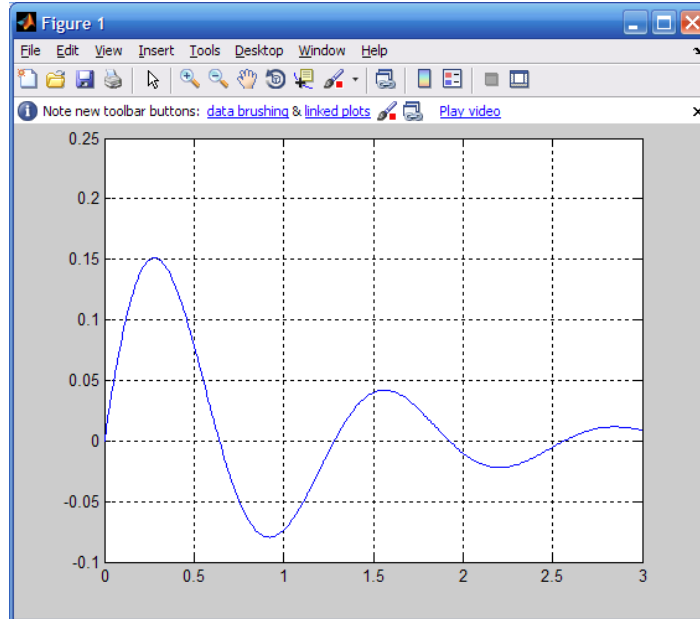

19.

a. Assume a particular solution of

Substitute into the differential equation and obtain

$$(7C + 2D) \cos(2t) + (-2C + 7D) \sin(2t) = 5 \cos(2t)$$

Equating like coefficients,

$$7C + 2D = 5$$

$$-2C + 7D = 0$$

From which,  $C = \frac{35}{53}$  and  $D = \frac{10}{53}$ .

The characteristic polynomial is

$$\mathcal{M} + 7 = 0$$

Thus, the total solution is

$$x(t) = A e^{-7t} + \left( \frac{35}{53} \cos[2t] + \frac{10}{53} \sin[2t] \right)$$

Solving for the arbitrary constants,  $x(0) = A + \frac{35}{53} = 0$ . Therefore,  $A = -\frac{35}{53}$ . The final solution is

$$x(t) = \left( -\frac{35}{53} \right) e^{-7t} + \left( \frac{35}{53} \cos[2t] + \frac{10}{53} \sin[2t] \right)$$

b. Assume a particular solution of



$$x_p = A\sin 3t + B\cos 3t$$

Substitute into the differential equation and obtain

$$(18A - B)\cos(3t) - (A + 18B)\sin(3t) = 5\sin(3t)$$

Therefore,  $18A - B = 0$  and  $-(A + 18B) = 5$ . Solving for A and B we obtain

$$x_p = (-1/65)\sin 3t + (-18/65)\cos 3t$$

The characteristic polynomial is

$$M^2 + 6M + 8 = (M + 4)(M + 2)$$

Thus, the total solution is

$$x = C e^{-4t} + D e^{-2t} + \left( -\frac{18}{65} \cos(3t) - \frac{1}{65} \sin(3t) \right)$$

Solving for the arbitrary constants,  $x(0) = C + D - \frac{18}{65} = 0$ .

Also, the derivative of the solution is

$$\frac{dx}{dt} = -\frac{3}{65} \cos(3t) + \frac{54}{65} \sin(3t) - 4C e^{-4t} - 2D e^{-2t}$$

Solving for the arbitrary constants,  $\dot{x}(0) - \frac{3}{65} - 4C - 2D = 0$ , or  $C = -\frac{3}{10}$  and  $D = \frac{15}{26}$ .

The final solution is

$$x = -\frac{18}{65} \cos(3t) - \frac{1}{65} \sin(3t) - \frac{3}{10} e^{-4t} + \frac{15}{26} e^{-2t}$$

c. Assume a particular solution of

$$x_p = A$$

Substitute into the differential equation and obtain  $25A = 10$ , or  $A = 2/5$ .

The characteristic polynomial is

$$M^2 + 8M + 25 = (M + 4 + 3i)(M + 4 - 3i)$$

Thus, the total solution is

$$x = \frac{2}{5} + e^{-4t} (B \sin(3t) + C \cos(3t))$$

Solving for the arbitrary constants,  $x(0) = C + 2/5 = 0$ . Therefore,  $C = -2/5$ . Also, the derivative of the solution is

$$\frac{dx}{dt} = ((3B - 4C) \cos(3t) - (4B + 3C) \sin(3t)) e^{-4t}$$

Solving for the arbitrary constants,  $\dot{x}(0) = 3B - 4C = 0$ . Therefore,  $B = -8/15$ . The final solution is

$$x(t) = \frac{2}{5} - e^{-4t} \left( \frac{8}{15} \sin(3t) + \frac{2}{5} \cos(3t) \right)$$

20.

a. Assume a particular solution of

$$x_p(t) = C \cos(2t) + D \sin(2t)$$

Substitute into the differential equation and obtain

$$-2(C - 2D) \cos(2t) - 4\left(C + \frac{1}{2}D\right) \sin(2t) = \sin(2t)$$

Equating like coefficients,

$$-2(C - 2D) = 0$$

$$-4\left(C + \frac{1}{2}D\right) = 1$$

From which,  $C = -\frac{1}{5}$  and  $D = -\frac{1}{10}$ .

The characteristic polynomial is

$$\mathcal{M}^2 + 2\mathcal{M} + 2 = (\mathcal{M} + 1 + i)(\mathcal{M} + 1 - i)$$

Thus, the total solution is

$$x = -\frac{1}{5} \cos(2t) - \frac{1}{10} \sin(2t) + e^{-t} (A \cos[t] + B \sin[t])$$

Solving for the arbitrary constants,  $x(0) = A - \frac{1}{5} = 2$ . Therefore,  $A = \frac{11}{5}$ . Also, the derivative of the

solution is

$$\frac{dx}{dt} = -\frac{1}{5} \cos(2t) + \frac{2}{5} \sin(2t) + (-A + B) e^{-t} \cos(t) - (A + B) e^{-t} \sin(t)$$

Solving for the arbitrary constants,  $\dot{x}(0) = -A + B - 0.2 = -3$ . Therefore,  $B = -\frac{3}{5}$ . The final solution

is

$$x(t) = -\frac{1}{5} \cos(2t) - \frac{1}{10} \sin(2t) + e^{-t} \left( \frac{11}{5} \cos(t) - \frac{3}{5} \sin(t) \right)$$

b. Assume a particular solution of

$$x_p = Ce^{-2t} + Dt + E$$

Substitute into the differential equation and obtain

$$C e^{-2t} + D t + 2D + E = 5e^{-2t} + t$$

Equating like coefficients,  $C = 5$ ,  $D = 1$ , and  $2D + E = 0$ .

From which,  $C = 5$ ,  $D = 1$ , and  $E = -2$ .

The characteristic polynomial is

$$M^2 + 2M + 1 = (M + 1)^2$$

Thus, the total solution is

$$x(t) = A e^{-t} + B e^{-t} t + 5e^{-2t} + t - 2$$

Solving for the arbitrary constants,  $x(0) = A + 5 - 2 = 2$  Therefore,  $A = -1$ . Also, the derivative of the solution is

$$\frac{dx}{dt} = (-A + B)e^{-t} - Bte^{-t} - 10e^{-2t} + 1$$

Solving for the arbitrary constants,  $\dot{x}(0) = B - 8 = 1$ . Therefore,  $B = 9$ . The final solution is

$$x(t) = -e^{-t} + 9te^{-t} + 5e^{-2t} + t - 2$$

c. Assume a particular solution of

$$x_p = Ct^2 + Dt + E$$

Substitute into the differential equation and obtain

$$4Ct^2 + 4Dt + 2C + 4E = t^2$$

Equating like coefficients,  $C = \frac{1}{4}$ ,  $D = 0$ , and  $2C + 4E = 0$ .

From which,  $C = \frac{1}{4}$ ,  $D = 0$ , and  $E = -\frac{1}{8}$ .

The characteristic polynomial is

$$M^2 + 4 = (M + 2i)(M - 2i)$$

Thus, the total solution is

$$x(t) = A \cos(2t) + B \sin(2t) + \frac{1}{4}t^2 - \frac{1}{8}$$

Solving for the arbitrary constants,  $x(0) = A - \frac{1}{8} = 1$  Therefore,  $A = \frac{9}{8}$ . Also, the derivative of the

solution is

$$\frac{dx}{dt} = 2B \cos(2t) - 2A \sin(2t) + \frac{1}{2}t$$

Solving for the arbitrary constants,  $\dot{x}(0) = 2B = 2$ . Therefore,  $B = 1$ . The final solution is

$$x(t) = \frac{9}{8} \cos(2t) + \sin(2t) + \frac{1}{4} t^2 - \frac{1}{8}$$

21.

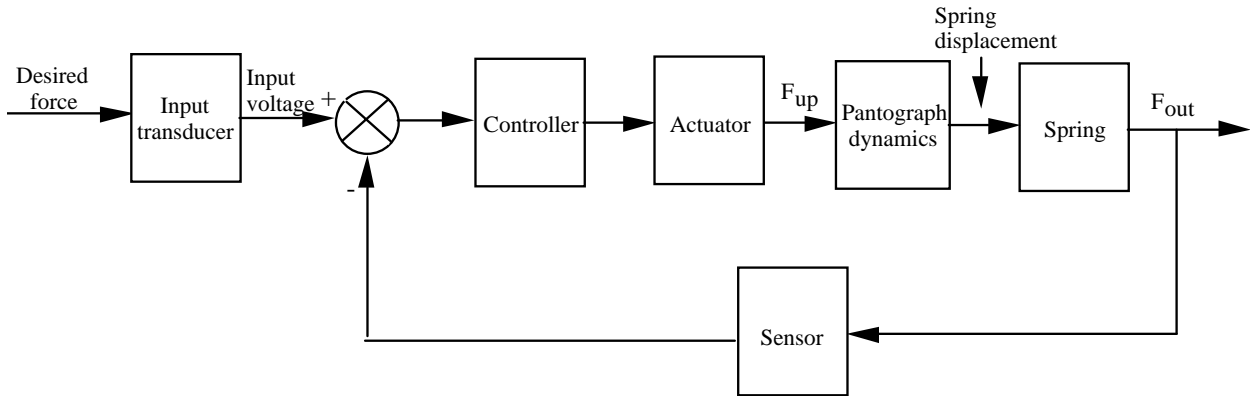

22.

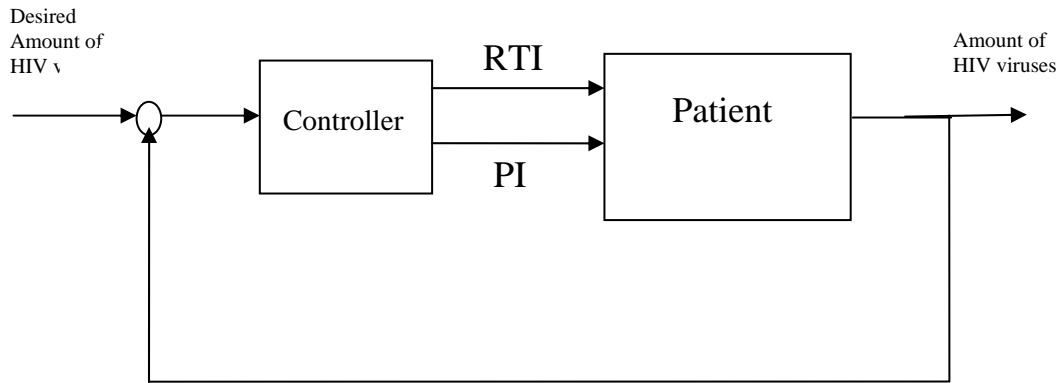

23.

a.

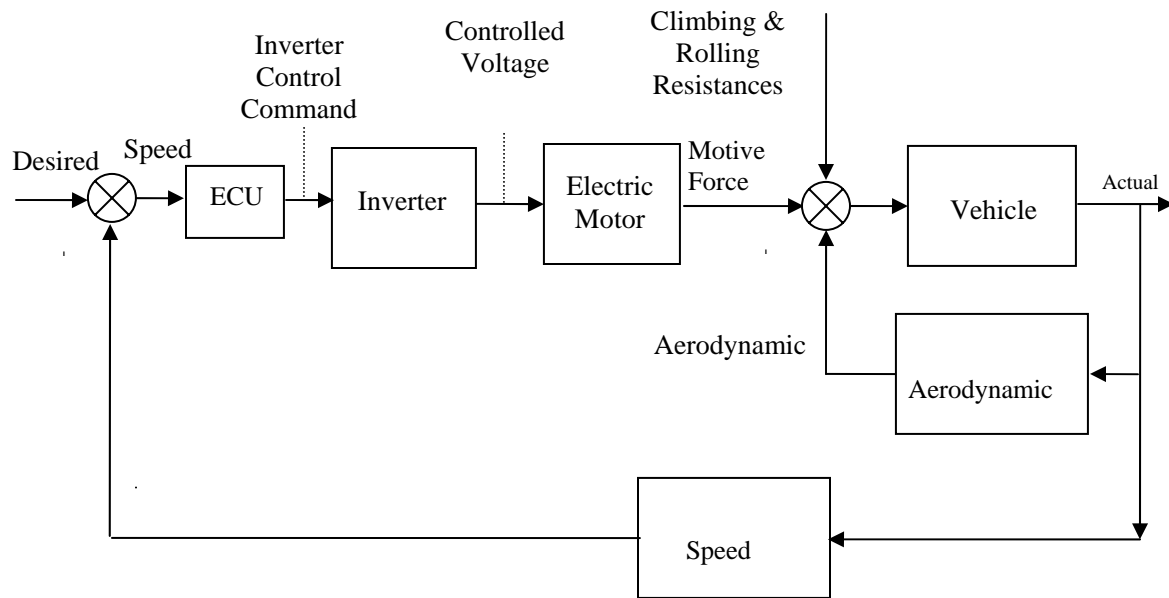

b.

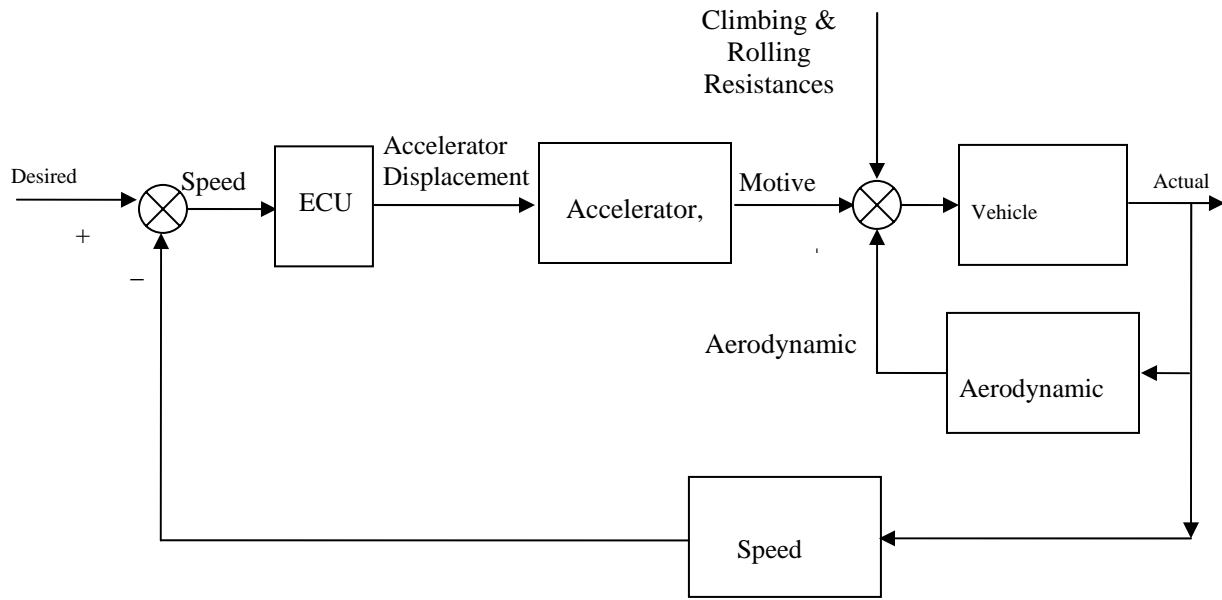

c.

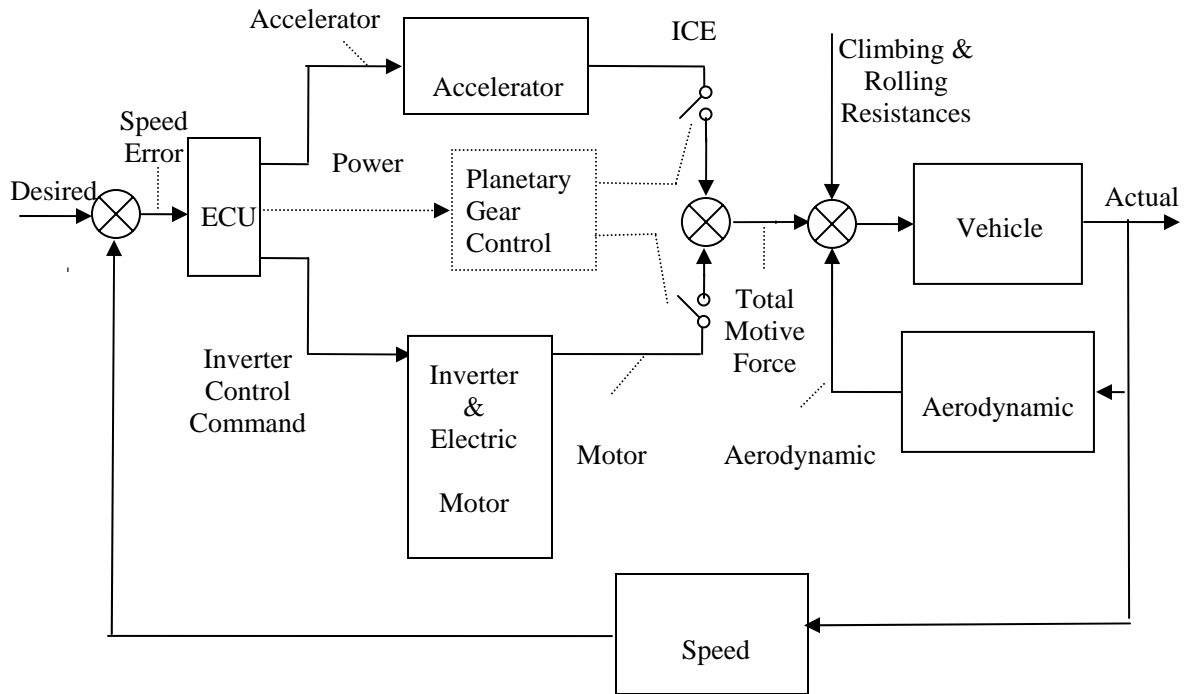

# T W O

## Modeling in the Frequency Domain

### SOLUTIONS TO CASE STUDIES CHALLENGES

#### Antenna Control: Transfer Functions

Finding each transfer function:

$$\text{Pot: } \frac{V_i(s)}{\theta_i(s)} = \frac{10}{\pi} ;$$

$$\text{Pre-Amp: } \frac{V_p(s)}{V_i(s)} = K;$$

$$\text{Power Amp: } \frac{E_a(s)}{V_p(s)} = \frac{150}{s+150}$$

$$\text{Motor: } J_m = 0.05 + 5\left(\frac{50}{250}\right)^2 = 0.25$$

$$D_m = 0.01 + 3\left(\frac{50}{250}\right)^2 = 0.13$$

$$\frac{K_t}{R_a} = \frac{1}{5}$$

$$\frac{K_t K_b}{R_a} = \frac{1}{5}$$

$$\text{Therefore: } \frac{\theta_m(s)}{E_a(s)} = \frac{\frac{K_t}{R_a J_m}}{s\left(s + \frac{1}{J_m}\left(D_m + \frac{K_t K_b}{R_a}\right)\right)} = \frac{0.8}{s(s+1.32)}$$

$$\text{And: } \frac{\theta_o(s)}{E_a(s)} = \frac{1}{5} \frac{\theta_m(s)}{E_a(s)} = \frac{0.16}{s(s+1.32)}$$

#### Transfer Function of a Nonlinear Electrical Network

Writing the differential equation,  $\frac{d(i_0 + \delta i)}{dt} + 2(i_0 + \delta i)^2 - 5 = v(t)$ . Linearizing  $i^2$  about  $i_0$ ,

$$(i_0 + \delta i)^2 - i_0^2 = 2i_0 \delta i \quad \Big|_{i=i_0} \quad \delta i = 2i_0 \delta i. \text{ Thus, } (i_0 + \delta i)^2 = i_0^2 + 2i_0 \delta i.$$



Substituting into the differential equation yields,  $\frac{d\delta i}{dt} + 2i_0^2 + 4i_0\delta i - 5 = v(t)$ . But, the resistor voltage equals the battery voltage at equilibrium when the supply voltage is zero since the voltage across the inductor is zero at dc. Hence,  $2i_0^2 = 5$ , or  $i_0 = 1.58$ . Substituting into the linearized differential equation,  $\frac{d\delta i}{dt} + 6.32\delta i = v(t)$ . Converting to a transfer function,  $\frac{\delta i(s)}{V(s)} = \frac{1}{s+6.32}$ . Using the linearized  $i$  about  $i_0$ , and the fact that  $v_r(t)$  is 5 volts at equilibrium, the linearized  $v_r(t)$  is  $v_r(t) = 2i^2 = 2(i_0 + \delta i)^2 = 2(i_0^2 + 2i_0\delta i) = 5 + 6.32\delta i$ . For excursions away from equilibrium,  $v_r(t) - 5 = 6.32\delta i = \delta v_r(t)$ . Therefore, multiplying the transfer function by 6.32, yields,  $\frac{\delta V_r(s)}{V(s)} = \frac{6.32}{s+6.32}$  as the transfer function about  $v(t) = 0$ .

## ANSWERS TO REVIEW QUESTIONS

1. Transfer function
2. Linear time-invariant
3. Laplace
4.  $G(s) = C(s)/R(s)$ , where  $c(t)$  is the output and  $r(t)$  is the input.
5. Initial conditions are zero
6. Equations of motion
7. Free body diagram
8. There are direct analogies between the electrical variables and components and the mechanical variables and components.
9. Mechanical advantage for rotating systems
10. Armature inertia, armature damping, load inertia, load damping
11. Multiply the transfer function by the gear ratio relating armature position to load position.
12. (1) Recognize the nonlinear component, (2) Write the nonlinear differential equation, (3) Select the equilibrium solution, (4) Linearize the nonlinear differential equation, (5) Take the Laplace transform of the linearized differential equation, (6) Find the transfer function.

## SOLUTIONS TO PROBLEMS

1.

$$\text{a. } F(s) = \int_0^{\infty} e^{-st} dt = -\frac{1}{s} e^{-st} \Big|_0^{\infty} = \frac{1}{s}$$

$$\text{b. } F(s) = \int_0^{\infty} te^{-st} dt = \frac{e^{-st}}{s^2} (-st - 1) \Big|_0^{\infty} = \frac{-(st + 1)}{s^2 e^{st}} \Big|_0^{\infty}$$

Using L'Hopital's Rule

$$F(s)\Big|_{t \rightarrow \infty} = \frac{-s}{s^3 e^{st}} \Big|_{t \rightarrow \infty} = 0. \text{ Therefore, } F(s) = \frac{1}{s^2}.$$

$$\text{c. } F(s) = \int_0^{\infty} \sin \omega t e^{-st} dt = \frac{e^{-st}}{s^2 + \omega^2} (-s \sin \omega t - \omega \cos \omega t) \Big|_0^{\infty} = \frac{\omega}{s^2 + \omega^2}$$

$$\text{d. } F(s) = \int_0^{\infty} \cos \omega t e^{-st} dt = \frac{e^{-st}}{s^2 + \omega^2} (-s \cos \omega t + \omega \sin \omega t) \Big|_0^{\infty} = \frac{s}{s^2 + \omega^2}$$

2.

a. Using the frequency shift theorem and the Laplace transform of  $\sin \omega t$ ,  $F(s) = \frac{\omega}{(s+a)^2 + \omega^2}$ .

b. Using the frequency shift theorem and the Laplace transform of  $\cos \omega t$ ,  $F(s) = \frac{(s+a)}{(s+a)^2 + \omega^2}$ .

c. Using the integration theorem, and successively integrating  $u(t)$  three times,  $\int dt = t$ ;  $\int t dt = \frac{t^2}{2}$ ;

$$\int \frac{t^2}{2} dt = \frac{t^3}{6}, \text{ the Laplace transform of } t^3 u(t), F(s) = \frac{6}{s^4}.$$

3.

a. The Laplace transform of the differential equation, assuming zero initial conditions,

is,  $(s+7)X(s) = \frac{5s}{s^2+2^2}$ . Solving for  $X(s)$  and expanding by partial fractions,

$$\frac{5s}{(s+7)(s^2+4)} = -\frac{35}{53} \frac{1}{s+7} + \frac{5}{53} \frac{7s+4}{s^2+4}$$

Or,

$$\frac{5s}{(s+7)(s^2+4)} = -\frac{35}{53} \frac{1}{s+7} + \frac{5}{53} \frac{7s+2\sqrt{4}}{s^2+4}$$

Taking the inverse Laplace transform,  $x(t) = -\frac{35}{53} e^{-7t} + \left(\frac{35}{53} \cos 2t + \frac{10}{53} \sin 2t\right)$ .

b. The Laplace transform of the differential equation, assuming zero initial conditions, is,

$$(s^2+6s+8)X(s) = \frac{15}{s^2+9}.$$

Solving for  $X(s)$

$$X(s) = \frac{15}{(s^2+9)(s^2+6s+8)}$$

and expanding by partial fractions,

$$X(s) = -\frac{3}{65} \frac{6s + \frac{1}{\sqrt{9}}\sqrt{9}}{s^2+9} - \frac{3}{10} \frac{1}{s+4} + \frac{15}{26} \frac{1}{s+2}$$

Taking the inverse Laplace transform,

$$x(t) = -\frac{18}{65} \cos(3t) - \frac{1}{65} \sin(3t) - \frac{3}{10} e^{-4t} + \frac{15}{26} e^{-2t}$$

c. The Laplace transform of the differential equation is, assuming zero initial conditions,

$$(s^2+8s+25)x(s) = \frac{10}{s}. \text{ Solving for } X(s)$$

$$X(s) = \frac{10}{s(s^2 + 8s + 25)}$$

and expanding by partial fractions,

$$X(s) = \frac{2}{5} \frac{1}{s} - \frac{2}{5} \frac{1(s+4) + \frac{4}{\sqrt{9}} \sqrt{9}}{s+4^2+9}$$

Taking the inverse Laplace transform,

$$x(t) = \frac{2}{5} - e^{-4t} \left( \frac{8}{15} \sin(3t) + \frac{2}{5} \cos(3t) \right)$$

4.

a. Taking the Laplace transform with initial conditions,  $s^2X(s)-4s+4+2sX(s)-8+2X(s) = \frac{2}{s^2+2^2}$ .

Solving for X(s),

$$X(s) = \frac{4s^3 + 4s^2 + 16s + 18}{(s^2 + 4)(s^2 + 2s + 2)}.$$

Expanding by partial fractions

$$X(s) = -\left(\frac{1}{5}\right) \frac{s + \frac{1}{2} \cdot 2}{s^2 + 2^2} + \left(\frac{1}{5}\right) \frac{21(s+1) + 2}{(s+1)^2 + 1}$$

$$\text{Therefore, } x(t) = \frac{1}{5} \left[ 21e^{-t} \cos t + \frac{2}{21} e^{-t} \sin t - \frac{1}{2} \sin 2t - \cos 2t \right]$$

b. Taking the Laplace transform with initial conditions,  $s^2X(s)-4s-1+2sX(s)-8+X(s) = \frac{5}{s+2} + \frac{1}{s^2}$ .

Solving for X(s),

$$X(s) = \frac{4s^4 + 17s^3 + 23s^2 + s + 2}{s^2(s+1)^2(s+2)}$$

$$X(s) = \frac{1}{s^2} - \frac{2}{s} + \frac{11}{(s+1)^2} + \frac{1}{(s+1)} + \frac{5}{(s+2)}$$

$$\text{Therefore } x(t) = t - 2 + 11te^{-t} + e^{-t} + 5e^{-2t}.$$

c. Taking the Laplace transform with initial conditions,  $s^2X(s)-s-2+4X(s) = \frac{2}{s^3}$ . Solving for X(s),

$$X(s) = \frac{2s^4 + 3s^3 + 2}{s^3(s^2 + 4)}$$

$$X(s) = \frac{\frac{17}{8}s + \frac{3}{2} \cdot 2}{s^2 + 4} + \frac{1/2}{s^3} - \frac{1/8}{s}$$

Therefore  $x(t) = \frac{17}{8} \cos 2t + \frac{3}{2} \sin 2t + \frac{1}{4} t^2 - \frac{1}{8}$ .

5.

**Program:**

```
syms t
'a'
theta=45*pi/180
f=8*t^2*cos(3*t+theta);
pretty(f)
F=laplace(f);
F=simple(F);
pretty(F)
'b'
theta=60*pi/180
f=3*t*exp(-2*t)*sin(4*t+theta);
pretty(f)
F=laplace(f);
F=simple(F);
pretty(F)
```

**Computer response:**

ans =

a

theta =

0.7854

$$8 t^2 \cos\left(\frac{\pi}{4} + 3 t\right)$$

$$\frac{8 t^{1/2} (s + 3) (s^2 - 12 s + 9)}{(s^2 + 9)^3}$$

ans =

b

theta =

1.0472

$$\frac{3 t \sin\left(\frac{t}{3}\right) \exp(-2 t)}{\sqrt{12 s^2 + 6 s} \sqrt{s^2 - 18 s + 24} + \frac{1}{2} \frac{s^2}{s^2 + 4 s + 20}}$$

6.

**Program:**

```
syms s
'a'
G=(s^2+3*s+10)*(s+5)/[(s+3)*(s+4)*(s^2+2*s+100)];
pretty(G)
g=ilaplace(G);
pretty(g)
'b'
G=(s^3+4*s^2+2*s+6)/[(s+8)*(s^2+8*s+3)*(s^2+5*s+7)];
pretty(G)
g=ilaplace(G);
pretty(g)
```

**Computer response:**

ans =

a

$$\frac{(s+5)(s^2+3s+10)}{(s+3)(s+4)(s^2+2s+100)}$$

$$20 \exp(-3 t) / 103 - 7 \exp(-4 t) / 54 + \frac{5203 \exp(-t) \left( \cos\left(\frac{3}{11} t\right) - \frac{1}{57233} \sin\left(\frac{3}{11} t\right) \right)}{5562}$$

ans =

b

$$\frac{s^3 + 4s^2 + 2s + 6}{(s+8)(s^2+8s+3)(s^2+5s+7)}$$

---

$$1199 \exp(-4t) \left[ \cosh\left(\frac{13}{2}t\right) - \frac{4262}{15587} \sinh\left(\frac{13}{2}t\right) \right]$$

---

$$417$$

$$65 \exp\left(-\frac{5}{2}t\right) \cos\left(\frac{3}{2}t\right) + \frac{131}{15} \sin\left(\frac{3}{2}t\right) + \frac{266}{93} \exp(-8t)$$

---

$$4309 \qquad \qquad \qquad 93$$

7.

The Laplace transform of the differential equation, assuming zero initial conditions, is,

$$(s^3+3s^2+5s+1)Y(s) = (s^3+4s^2+6s+8)X(s).$$

$$\text{Solving for the transfer function, } \frac{Y(s)}{X(s)} = \frac{s^3 + 4s^2 + 6s + 8}{s^3 + 3s^2 + 5s + 1}.$$

8.

a. Cross multiplying,  $(s^2+5s+10)X(s) = 7F(s)$ .

$$\text{Taking the inverse Laplace transform, } \frac{d^2x}{dt^2} + 5\frac{dx}{dt} + 10x = 7f.$$

b. Cross multiplying after expanding the denominator,  $(s^2+21s+110)X(s) = 15F(s)$ .

$$\text{Taking the inverse Laplace transform, } \frac{d^2x}{dt^2} + 21\frac{dx}{dt} + 110x = 15f.$$

c. Cross multiplying,  $(s^3+11s^2+12s+18)X(s) = (s+3)F(s)$ .

$$\text{Taking the inverse Laplace transform, } \frac{d^3x}{dt^3} + 11\frac{d^2x}{dt^2} + 12\frac{dx}{dt} + 18x = df/dt + 3f.$$

9.

$$\text{The transfer function is } \frac{C(s)}{R(s)} = \frac{s^5 + 2s^4 + 4s^3 + s^2 + 4}{s^6 + 7s^5 + 3s^4 + 2s^3 + s^2 + 5}.$$

$$\text{Cross multiplying, } (s^6+7s^5+3s^4+2s^3+s^2+5)C(s) = (s^5+2s^4+4s^3+s^2+4)R(s).$$

Taking the inverse Laplace transform assuming zero initial conditions,

$$\frac{d^6c}{dt^6} + 7\frac{d^5c}{dt^5} + 3\frac{d^4c}{dt^4} + 2\frac{d^3c}{dt^3} + \frac{d^2c}{dt^2} + 5c = \frac{d^5r}{dt^5} + 2\frac{d^4r}{dt^4} + 4\frac{d^3r}{dt^3} + \frac{d^2r}{dt^2} + 4r.$$

10.

$$\text{The transfer function is } \frac{C(s)}{R(s)} = \frac{s^4 + 2s^3 + 5s^2 + s + 1}{s^5 + 3s^4 + 2s^3 + 4s^2 + 5s + 2}.$$

Cross multiplying,  $(s^5+3s^4+2s^3+4s^2+5s+2)C(s) = (s^4+2s^3+5s^2+s+1)R(s)$ .

Taking the inverse Laplace transform assuming zero initial conditions,

$$\frac{d^5c}{dc^5} + 3\frac{d^4c}{dt^4} + 2\frac{d^3c}{dt^3} + 4\frac{d^2c}{dt^2} + 5\frac{dc}{dt} + 2c = \frac{d^4r}{dt^4} + 2\frac{d^3r}{dt^3} + 5\frac{d^2r}{dt^2} + \frac{dr}{dt} + r.$$

Substituting  $r(t) = t^3$ ,  $\frac{d^5c}{dc^5} + 3\frac{d^4c}{dt^4} + 2\frac{d^3c}{dt^3} + 4\frac{d^2c}{dt^2} + 5\frac{dc}{dt} + 2c$

$$= 18\delta(t) + (36 + 90t + 9t^2 + 3t^3) u(t).$$

11.

Taking the Laplace transform of the differential equation,  $s^2X(s)-s+1+2sX(s)-2+3x(s)=R(s)$ .

Collecting terms,  $(s^2+2s+3)X(s) = R(s)+s+1$ .

Solving for  $X(s)$ ,  $X(s) = \frac{R(s)}{s^2 + 2s + 3} + \frac{s + 1}{s^2 + 2s + 3}$ .

The block diagram is shown below, where  $R(s) = 1/s$ .

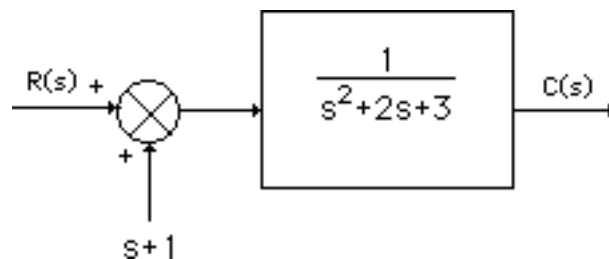

12.

**Program:**

```
'Factored'
Gzpk=zpk([-15 -26 -72],[0 -55 roots([1 5 30])' roots([1 27 52])'],5)
'Polynomial'
Gp=tf(Gzpk)
```

**Computer response:**

ans =

Factored

Zero/pole/gain:

$$\frac{5 (s+15) (s+26) (s+72)}{s (s+55) (s+24.91) (s+2.087) (s^2 + 5s + 30)}$$

ans =

Polynomial

Transfer function:

$$\frac{5 s^3 + 565 s^2 + 16710 s + 140400}{s^6 + 87 s^5 + 1977 s^4 + 1.301e004 s^3 + 6.041e004 s^2 + 8.58e004 s}$$

13.

**Program:**

```
'Polynomial'
Gtf=tf([1 25 20 15 42],[1 13 9 37 35 50])
```

```
'Factored'
Gzpk=zpk(Gtf)
```

**Computer response:**

```
ans =
```

```
Polynomial
```

```
Transfer function:
```

$$\frac{s^4 + 25s^3 + 20s^2 + 15s + 42}{s^5 + 13s^4 + 9s^3 + 37s^2 + 35s + 50}$$

```
ans =
```

```
Factored
```

```
Zero/pole/gain:
```

$$\frac{(s+24.2)(s+1.35)(s^2 - 0.5462s + 1.286)}{(s+12.5)(s^2 + 1.463s + 1.493)(s^2 - 0.964s + 2.679)}$$

14.

**Program:**

```
numg=[-5 -70];
deng=[0 -45 -55 (roots([1 7 110]))' (roots([1 6 95]))'];
[numg,deng]=zp2tf(numg',deng',1e4);
Gtf=tf(numg,deng)
G=zpk(Gtf)
[r,p,k]=residue(numg,deng)
```

**Computer response:**

```
Transfer function:
```

$$\frac{10000s^2 + 750000s + 3.5e006}{s^7 + 113s^6 + 4022s^5 + 58200s^4 + 754275s^3 + 4.324e006s^2 + 2.586e007s}$$

```
Zero/pole/gain:
```

$$\frac{10000(s+70)(s+5)}{s(s+55)(s+45)(s^2 + 6s + 95)(s^2 + 7s + 110)}$$

```
r =
```

```
-0.0018
 0.0066
 0.9513 + 0.0896i
 0.9513 - 0.0896i
-1.0213 - 0.1349i
-1.0213 + 0.1349i
 0.1353
```

```
p =
```

```
-55.0000
-45.0000
 -3.5000 + 9.8869i
 -3.5000 - 9.8869i
 -3.0000 + 9.2736i
 -3.0000 - 9.2736i
 0
```

```
k =
```

```
[]
```



15.

**Program:**

```

syms s
'(a)'
Ga=45*[(s^2+37*s+74)*(s^3+28*s^2+32*s+16)]...
/[(s+39)*(s+47)*(s^2+2*s+100)*(s^3+27*s^2+18*s+15)];
'Ga symbolic'
pretty(Ga)
[numga,denga]=numden(Ga);
numga=sym2poly(numga);
denga=sym2poly(denga);
'Ga polynimial'
Ga=tf(numga,denga)
'Ga factored'
Ga=zpk(Ga)
'(b)'
Ga=56*[(s+14)*(s^3+49*s^2+62*s+53)]...
/[(s^2+88*s+33)*(s^2+56*s+77)*(s^3+81*s^2+76*s+65)];
'Ga symbolic'
pretty(Ga)
[numga,denga]=numden(Ga);
numga=sym2poly(numga);
denga=sym2poly(denga);
'Ga polynimial'
Ga=tf(numga,denga)
'Ga factored'
Ga=zpk(Ga)

```

**Computer response:**

ans =

(a)

ans =

Ga symbolic

$$45 \frac{(s^2 + 37s + 74)(s^3 + 28s^2 + 32s + 16)}{(s + 39)(s + 47)(s^2 + 2s + 100)(s^3 + 27s^2 + 18s + 15)}$$

ans =

Ga polynimial

Transfer function:

$$\frac{45s^5 + 2925s^4 + 51390s^3 + 147240s^2 + 133200s + 53280}{s^7 + 115s^6 + 4499s^5 + 70700s^4 + 553692s^3 + 5.201e006s^2 + 3.483e006s + 2.75e006}$$

ans =

Ga factored

Zero/pole/gain:

$$\frac{45(s+34.88)(s+26.83)(s+2.122)(s^2 + 1.17s + 0.5964)}{(s+47)(s+39)(s+26.34)(s^2 + 0.6618s + 0.5695)(s^2 + 2s + 100)}$$

ans =

(b)

ans =

Ga symbolic

$$56 \frac{(s + 14)^3 (s^2 + 49s + 62s + 53)}{(s^2 + 88s + 33)(s^2 + 56s + 77)(s^3 + 81s^2 + 76s + 65)}$$

ans =

Ga polynomial

Transfer function:

$$\frac{56 s^4 + 3528 s^3 + 41888 s^2 + 51576 s + 41552}{s^7 + 225 s^6 + 16778 s^5 + 427711 s^4 + 1.093e006 s^3 + 1.189e006 s^2 + 753676 s + 165165}$$

ans =

Ga factored

Zero/pole/gain:

$$\frac{56 (s+47.72) (s+14) (s^2 + 1.276s + 1.111)}{(s+87.62) (s+80.06) (s+54.59) (s+1.411) (s+0.3766) (s^2 + 0.9391s + 0.8119)}$$

16.

a. Writing the node equations,  $\frac{V_o - V_i}{s} + \frac{V_o}{s} + V_o = 0$ . Solve for  $\frac{V_o}{V_i} = \frac{1}{s+2}$ .

b. Thevenizing,

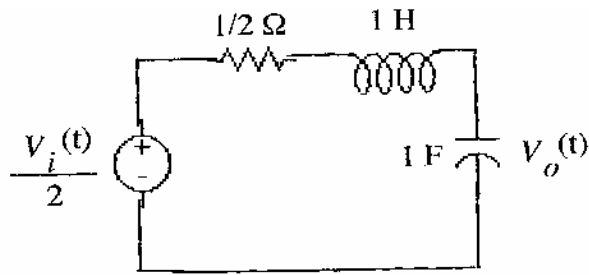

Using voltage division,  $V_o(s) = \frac{V_i(s)}{2} \frac{\frac{1}{s}}{\frac{1}{2} + s + \frac{1}{s}}$ . Thus,  $\frac{V_o(s)}{V_i(s)} = \frac{1}{2s^2 + s + 2}$

17.

a.

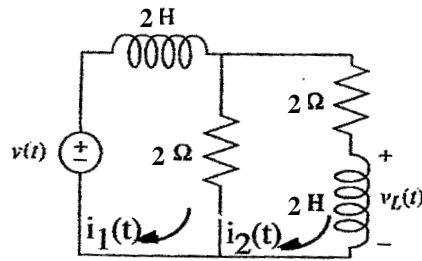

Writing mesh equations

$$(2s+2)I_1(s) - 2 I_2(s) = V_i(s)$$

$$-2I_1(s) + (2s+4)I_2(s) = 0$$

But from the second equation,  $I_1(s) = (s+2)I_2(s)$ . Substituting this in the first equation yields,

$$(2s+2)(s+2)I_2(s) - 2 I_2(s) = V_i(s)$$

or

$$I_2(s)/V_i(s) = 1/(2s^2 + 4s + 2)$$

But,  $V_L(s) = sI_2(s)$ . Therefore,  $V_L(s)/V_i(s) = s/(2s^2 + 4s + 2)$ .

b.

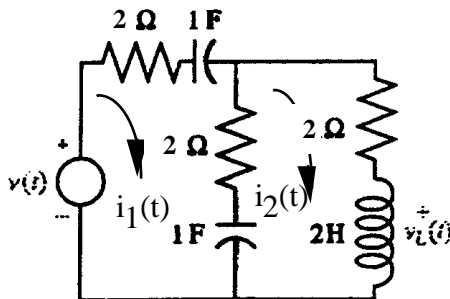

$$\begin{aligned}(4 + \frac{2}{s})I_1(s) - (2 + \frac{1}{s})I_2(s) &= V(s) \\ -(2 + \frac{1}{s})I_1(s) + (4 + \frac{1}{s} + 2s) &= 0\end{aligned}$$

Solving for  $I_2(s)$ :

$$I_2(s) = \frac{\begin{vmatrix} \frac{4s+2}{s} & V(s) \\ -\frac{(2s+1)}{s} & 0 \end{vmatrix}}{\begin{vmatrix} \frac{4s+2}{s} & -\frac{(2s+1)}{s} \\ -\frac{(2s+1)}{s} & (2s^2+4s+1) \end{vmatrix}} = \frac{sV(s)}{4s^2 + 6s + 1}$$

$$\text{Therefore, } \frac{V_L(s)}{V(s)} = \frac{2sI_2(s)}{V(s)} = \frac{2s^2}{4s^2 + 6s + 1}$$

18.

a.

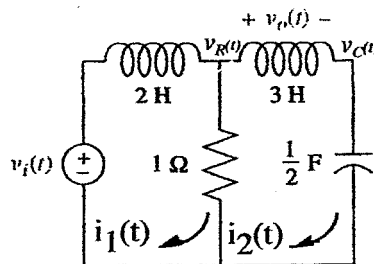

Writing mesh equations,

$$(2s + 1)I_1(s) - I_2(s) = V_i(s)$$

$$-I_1(s) + (3s + 1 + 2/s)I_2(s) = 0$$

Solving for  $I_2(s)$ ,

$$I_2(s) = \frac{\begin{vmatrix} 2s+1 & V_i(s) \\ -1 & 0 \end{vmatrix}}{\begin{vmatrix} 2s+1 & -1 \\ -1 & \frac{3s^2+s+2}{s} \end{vmatrix}}$$

Solving for  $I_2(s)/V_i(s)$ ,

$$\frac{I_2(s)}{V_i(s)} = \frac{s}{6s^3 + 5s^2 + 4s + 2}$$

But  $V_o(s) = I_2(s)3s$ . Therefore,  $G(s) = 3s^2/(6s^3 + 5s^2 + 4s + 2)$ .

b. Transforming the network yields,

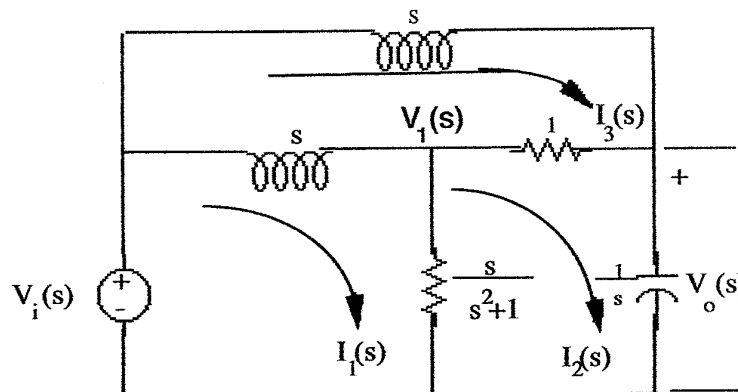

Writing the loop equations,

$$\begin{aligned} (s + \frac{s}{s^2+1})I_1(s) - \frac{s}{s^2+1}I_2(s) - sI_3(s) &= V_i(s) \\ -\frac{s}{s^2+1}I_1(s) + (\frac{s}{s^2+1} + 1 + \frac{1}{s})I_2(s) - I_3(s) &= 0 \\ -sI_1(s) - I_2(s) + (2s+1)I_3(s) &= 0 \end{aligned}$$

Solving for  $I_2(s)$ ,

$$I_2(s) = \frac{s(s^2 + 2s + 2)}{s^4 + 2s^3 + 3s^2 + 3s + 2} V_i(s)$$

But,  $V_o(s) = \frac{I_2(s)}{s} = \frac{(s^2 + 2s + 2)}{s^4 + 2s^3 + 3s^2 + 3s + 2} V_i(s)$ . Therefore,

$$\frac{V_o(s)}{V_i(s)} = \frac{s^2 + 2s + 2}{s^4 + 2s^3 + 3s^2 + 3s + 2}$$

19.

a. Writing the nodal equations yields,

$$\frac{V_R(s) - V_i(s)}{2s} + \frac{V_R(s)}{1} + \frac{V_R(s) - V_C(s)}{3s} = 0$$

$$-\frac{1}{3s} V_R(s) + \left(\frac{1}{2}s + \frac{1}{3s}\right) V_C(s) = 0$$

Rewriting and simplifying,

$$\frac{6s+5}{6s} V_R(s) - \frac{1}{3s} V_C(s) = \frac{1}{2s} V_i(s)$$

$$-\frac{1}{3s} V_R(s) + \left(\frac{3s^2+2}{6s}\right) V_C(s) = 0$$

Solving for  $V_R(s)$  and  $V_C(s)$ ,

$$V_R(s) = \frac{\begin{vmatrix} \frac{1}{2s} V_i(s) & -\frac{1}{3s} \\ 0 & \frac{3s^2+2}{6s} \end{vmatrix}}{\begin{vmatrix} \frac{6s+5}{6s} & -\frac{1}{3s} \\ -\frac{1}{3s} & \frac{3s^2+2}{6s} \end{vmatrix}}; \quad V_C(s) = \frac{\begin{vmatrix} \frac{6s+5}{6s} & \frac{1}{2s} V_i(s) \\ -\frac{1}{3s} & 0 \end{vmatrix}}{\begin{vmatrix} \frac{6s+5}{6s} & -\frac{1}{3s} \\ -\frac{1}{3s} & \frac{3s^2+2}{6s} \end{vmatrix}}$$

Solving for  $V_o(s)/V_i(s)$

$$\frac{V_o(s)}{V_i(s)} = \frac{V_R(s) - V_C(s)}{V_i(s)} = \frac{3s^2}{6s^3 + 5s^2 + 4s + 2}$$

**b.** Writing the nodal equations yields,

$$\frac{(V_1(s) - V_i(s))}{s} + \frac{(s^2 + 1)}{s} V_1(s) + (V_1(s) - V_o(s)) = 0$$

$$(V_o(s) - V_1(s)) + sV_o(s) + \frac{(V_o(s) - V_i(s))}{s} = 0$$

Rewriting and simplifying,

$$\left(s + \frac{2}{s} + 1\right) V_1(s) - V_o(s) = \frac{1}{s} V_i(s)$$

$$V_1(s) + \left(s + \frac{1}{s} + 1\right) V_o(s) = \frac{1}{s} V_i(s)$$

Solving for  $V_o(s)$

$$V_o(s) = \frac{(s^2 + 2s + 2)}{s^4 + 2s^3 + 3s^2 + 3s + 2} V_i(s).$$

Hence,

$$\frac{V_o(s)}{V_i(s)} = \frac{(s^2 + 2s + 2)}{s^4 + 2s^3 + 3s^2 + 3s + 2}$$

20.

a.

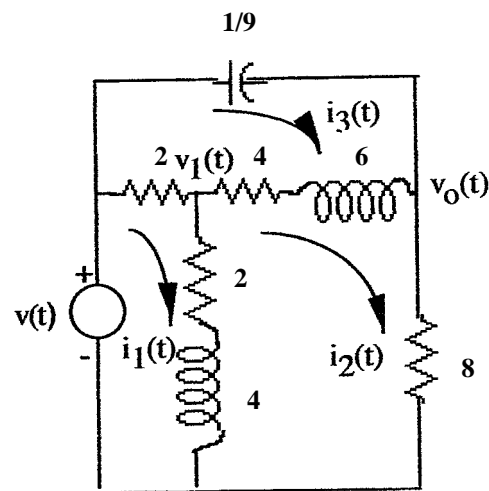

Mesh:

$$(4+4s)I_1(s) - (2+4s)I_2(s) - 2I_3(s) = V(s)$$

$$-(2+4s)I_1(s) + (14+10s)I_2(s) - (4+6s)I_3(s) = 0$$

$$-2I_1(s) - (4+6s)I_2(s) + (6+6s+\frac{9}{s})I_3(s) = 0$$

Nodal:

$$\frac{(V_1(s) - V(s))}{2} + \frac{V_1(s)}{2+4s} + \frac{(V_1(s) - V_o(s))}{4+6s} = 0$$

$$\frac{(V_o(s) - V_1(s))}{4+6s} + \frac{V_o(s)}{8} + \frac{(V_o(s) - V(s))}{9/s} = 0$$

or

$$\left[ \frac{6s^2 + 12s + 5}{12s^2 + 14s + 4} \right] V_1(s) - \left[ \frac{1}{6s + 4} \right] V_o(s) = \frac{1}{2} V(s)$$

$$- \left[ \frac{1}{6s + 4} \right] V_1(s) + \left[ \frac{24s^2 + 43s + 54}{216s + 144} \right] V_o(s) = \frac{s}{9} V(s)$$

b.

**Program:**

```

syms s V                                     %Construct symbolic object for frequency
                                              %variable 's' and V.

'Mesh Equations'
A2=[(4+4*s) V -2
    -(2+4*s) 0 -(4+6*s)
    -2 0 (6+6*s+(9/s))]                    %Form Ak = A2.
A=[(4+4*s) -(2+4*s) -2
    -(2+4*s) (14+10*s) -(4+6*s)
    -2 -(4+6*s) (6+6*s+(9/s))]            %Form A.
I2=det(A2)/det(A);                         %Use Cramer's Rule to solve for I2.
Gi=I2/V;                                   %Form transfer function, Gi(s) = I2(s)/V(s).
G=8*Gi;                                    %Form transfer function, G(s) = 8*I2(s)/V(s).
G=collect(G);                              %Simplify G(s).
'G(s) via Mesh Equations'                  %Display label.
pretty(G)                                   %Pretty print G(s)

'Nodal Equations'
A2=[(6*s^2+12*s+5)/(12*s^2+14*s+4) V/2
    -1/(6*s+4) s*(V/9)]                    %Form Ak = A2.
A=[(6*s^2+12*s+5)/(12*s^2+14*s+4) -1/(6*s+4)
    -1/(6*s+4) (24*s^2+43*s+54)/(216*s+144)] %Form A.
Vo=simple(det(A2))/simple(det(A));           %Use Cramer's Rule to solve for Vo.
G1=Vo/V;                                   %Form transfer function, G1(s) = Vo(s)/V(s).
G1=collect(G1);                            %Simplify G1(s).
'G(s) via Nodal Equations'                 %Display label.
pretty(G1)                                  %Pretty print G1(s)

```

**Computer response:**



Chapter 2: Modeling in the Frequency Domain 2-18

ans =

Mesh Equations

A2 =

$$\begin{bmatrix} 4s + 4, & V, & -2 \\ -4s - 2, & 0, & -6s - 4 \\ -2, & 0, & 6s + 9/s + 6 \end{bmatrix}$$

A =

$$\begin{bmatrix} 4s + 4, & -4s - 2, & -2 \\ -4s - 2, & 10s + 14, & -6s - 4 \\ -2, & -6s - 4, & 6s + 9/s + 6 \end{bmatrix}$$

ans =

G(s) via Mesh Equations

$$\frac{48s^3 + 96s^2 + 112s + 36}{48s^3 + 150s^2 + 220s + 117}$$

ans =

Nodal Equations

A2 =

$$\begin{bmatrix} (6s^2 + 12s + 5)/(12s^2 + 14s + 4), & V/2 \\ -1/(6s + 4), & (Vs)/9 \end{bmatrix}$$

A =

$$\begin{bmatrix} (6s^2 + 12s + 5)/(12s^2 + 14s + 4), & -1/(6s + 4) \\ -1/(6s + 4), & (24s^2 + 43s + 54)/(216s + 144) \end{bmatrix}$$

ans =

G(s) via Nodal Equations

$$\frac{48s^3 + 96s^2 + 112s + 36}{48s^3 + 150s^2 + 220s + 117}$$

21.

a.

$$Z_1(s) = 5 \times 10^5 + \frac{1}{2 \times 10^{-6} s}$$

$$Z_2(s) = 10^5 + \frac{1}{2 \times 10^{-6} s}$$

Therefore,

$$\frac{Z_2(s)}{Z_1(s)} = \frac{1(s+5)}{5(s+1)}$$

b.

$$Z_1(s) = 10^5 \left( \frac{5}{s} + 1 \right) = 10^5 \frac{(s+5)}{s}$$

$$Z_2(s) = 10^5 \left( 1 + \frac{5}{s+5} \right) = 10^5 \frac{(s+10)}{(s+5)}$$

Therefore,

$$\frac{Z_2(s)}{Z_1(s)} = \frac{s(s+10)}{(s+5)^2}$$

22.

a.

$$Z_1(s) = 4 \times 10^5 + \frac{1}{4 \times 10^{-6} s}$$

$$Z_2(s) = 1.1 \times 10^5 + \frac{1}{4 \times 10^{-6} s}$$

Therefore,

$$G(s) = \frac{Z_1(s) + Z_2(s)}{Z_1(s)} = 1.275 \frac{(s+0.98)}{(s+0.625)}$$

b.

$$Z_1(s) = 4 \times 10^5 + \frac{\frac{10^{11}}{s}}{4 \times 10^5 + \frac{0.25 \times 10^6}{s}}$$

$$Z_2(s) = 6 \times 10^5 + \frac{27.5 \frac{10^9}{s}}{110 \times 10^3 + \frac{0.25 \times 10^6}{s}}$$

Therefore,

$$\frac{Z_1(s) + Z_2(s)}{Z_1(s)} = \frac{2640s^2 + 8420s + 4275}{1056s^2 + 3500s + 2500}$$

23.

Writing the equations of motion, where  $x_2(t)$  is the displacement of the right member of spring,

$$(5s^2+4s+5)X_1(s) - 5X_2(s) = 0$$

$$-5X_1(s) + 5X_2(s) = F(s)$$

Adding the equations,

$$(5s^2+4s)X_1(s) = F(s)$$

$$\text{From which, } \frac{X_1(s)}{F(s)} = \frac{1}{s(5s+4)} = \frac{1/5}{s(s+4/5)}.$$

24.

Writing the equations of motion,

$$(s^2 + s + 1)X_1(s) - (s + 1)X_2(s) = F(s)$$

$$-(s + 1)X_1(s) + (s^2 + s + 1)X_2(s) = 0$$

Solving for  $X_2(s)$ ,

$$X_2(s) = \frac{\begin{vmatrix} (s^2 + s + 1) & F(s) \\ -(s + 1) & 0 \end{vmatrix}}{\begin{vmatrix} (s^2 + s + 1) & -(s + 1) \\ -(s + 1) & (s^2 + s + 1) \end{vmatrix}} = \frac{(s + 1)F(s)}{s^2(s^2 + 2s + 2)}$$

From which,

$$\frac{X_2(s)}{F(s)} = \frac{(s + 1)}{s^2(s^2 + 2s + 2)}.$$

25.

Let  $X_1(s)$  be the displacement of the left member of the spring and  $X_3(s)$  be the displacement of the mass.

Writing the equations of motion

$$2x_1(s) - 2x_2(s) = F(s)$$

$$-2X_1(s) + (5s + 2)X_2(s) - 5sX_3(s) = 0$$

$$-5sX_2(s) + (10s^2 + 7s)X_3(s) = 0$$

Solving for  $X_2(s)$ ,

$$X_2(s) = \frac{\begin{vmatrix} 5s^2+10 & F(s) \\ -10 & 0 \end{vmatrix}}{\begin{vmatrix} 5s^2+10 & -10 \\ -10 & \frac{1}{5}s+10 \end{vmatrix}} = \frac{10F(s)}{s(s^2+50s+2)}$$

$$\text{Thus, } \frac{X_2(s)}{F(s)} = \frac{1}{10} \frac{(10s+7)}{s(5s+1)}$$

26.

$$\begin{aligned}(s^2 + 6s + 9)X_1(s) - (3s + 5)X_2(s) &= 0 \\ -(3s + 5)X_1(s) + (2s^2 + 5s + 5)X_2(s) &= F(s)\end{aligned}$$

$$\text{Solving for } X_1(s); X_1(s) = \frac{\begin{bmatrix} 0 & -(3s+5) \\ F(s) & (2s^2+5s+5) \end{bmatrix}}{\begin{bmatrix} (s^2+6s+9) & -(3s+5) \\ -(3s+5) & (2s^2+5s+5) \end{bmatrix}} = \frac{(3s+5)F(s)}{2s^4 + 17s^3 + 44s^2 + 45s + 20}$$

$$\text{Thus } G(s) = X_1(s)/F(s) = \frac{(3s+5)}{2s^4 + 17s^3 + 44s^2 + 45s + 20}$$

27.

Writing the equations of motion,

$$\begin{aligned}(4s^2 + 2s + 6)X_1(s) - 2sX_2(s) &= 0 \\ -2sX_1(s) + (4s^2 + 4s + 6)X_2(s) - 6X_3(s) &= F(s) \\ -6X_2(s) + (4s^2 + 2s + 6)X_3(s) &= 0\end{aligned}$$

Solving for  $X_3(s)$ ,

$$X_3(s) = \frac{\begin{vmatrix} (4s^2 + 2s + 6) & -2s & 0 \\ -2s & (4s^2 + 4s + 6) & F(s) \\ 0 & -6 & 0 \end{vmatrix}}{\begin{vmatrix} (4s^2 + 2s + 6) & -2s & 0 \\ -2s & (4s^2 + 4s + 6) & -6 \\ 0 & -6 & (4s^2 + 2s + 6) \end{vmatrix}} = \frac{3F(s)}{s(8s^3 + 12s^2 + 26s + 18)}$$

$$\text{From which, } \frac{X_3(s)}{F(s)} = \frac{3}{s(8s^3 + 12s^2 + 26s + 18)}.$$

28.

a.

$$\begin{aligned}(4s^2 + 8s + 5)X_1(s) - 8sX_2(s) - 5X_3(s) &= F(s) \\ -8sX_1(s) + (4s^2 + 16s)X_2(s) - 4sX_3(s) &= 0 \\ -5X_1(s) - 4sX_2(s) + (4s + 5)X_3(s) &= 0\end{aligned}$$

Solving for  $X_3(s)$ ,

$$X_3(s) = \frac{\begin{vmatrix} (4s^2 + 8s + 5) & -8s & F(s) \\ -8s & (4s^2 + 16s) & 0 \\ -5 & -4s & 0 \end{vmatrix}}{\Delta} = \frac{F(s) \begin{vmatrix} -8s & (4s^2 + 16s) \\ -5 & -4s \end{vmatrix}}{\Delta}$$

or,

$$\frac{X_3(s)}{F(s)} = \frac{13s + 20}{4s(4s^3 + 25s^2 + 43s + 15)}$$

**b.**

$$\begin{aligned} (8s^2 + 4s + 16)X_1(s) - (4s + 1)X_2(s) - 15X_3(s) &= 0 \\ -(4s + 1)X_1(s) + (3s^2 + 20s + 1)X_2(s) - 16sX_3(s) &= F(s) \\ -15X_1(s) - 16sX_2(s) + (16s + 15)X_3(s) &= 0 \end{aligned}$$

Solving for  $X_3(s)$ ,

$$X_3(s) = \frac{\begin{vmatrix} (8s^2 + 4s + 16) & -(4s + 1) & 0 \\ -(4s + 1) & (3s^2 + 20s + 1) & F(s) \\ -15 & -16s & 0 \end{vmatrix}}{\Delta} = \frac{-F(s) \begin{vmatrix} (8s^2 + 4s + 16) & -(4s + 1) \\ -15 & -16s \end{vmatrix}}{\Delta}$$

or

$$\frac{X_3(s)}{F(s)} = \frac{128s^3 + 64s^2 + 316s + 15}{384s^5 + 1064s^4 + 3476s^3 + 165s^2}$$

**29.**

Writing the equations of motion,

$$\begin{aligned} (4s^2 + 4s + 8)X_1(s) - 4X_2(s) - 2sX_3(s) &= 0 \\ -4X_1(s) + (5s^2 + 3s + 4)X_2(s) - 3sX_3(s) &= F(s) \\ -2sX_1(s) - 3sX_2(s) + (5s^2 + 5s + 5)X_3(s) &= 0 \end{aligned}$$

30.

a.

Writing the equations of motion,

$$\begin{aligned}(5s^2 + 9s + 9)\theta_1(s) - (s + 9)\theta_2(s) &= 0 \\ -(s + 9)\theta_1(s) + (3s^2 + s + 12)\theta_2(s) &= T(s)\end{aligned}$$

b.

Defining

 $\theta_1(s)$  = rotation of  $J_1$  $\theta_2(s)$  = rotation between  $K_1$  and  $D_1$  $\theta_3(s)$  = rotation of  $J_3$  $\theta_4(s)$  = rotation of right - hand side of  $K_2$ 

the equations of motion are

$$\begin{aligned}(J_1s^2 + K_1)\theta_1(s) - K_1\theta_2(s) &= T(s) \\ -K_1\theta_1(s) + (D_1s + K_1)\theta_2(s) - D_1s\theta_3(s) &= 0 \\ -D_1s\theta_2(s) + (J_2s^2 + D_1s + K_2)\theta_3(s) - K_2\theta_4(s) &= 0 \\ -K_2\theta_3(s) + (D_2s + (K_2 + K_3))\theta_4(s) &= 0\end{aligned}$$

31.

Writing the equations of motion,

$$\begin{aligned}(s^2 + 2s + 1)\theta_1(s) - (s + 1)\theta_2(s) &= T(s) \\ -(s + 1)\theta_1(s) + (2s + 1)\theta_2(s) &= 0\end{aligned}$$

Solving for  $\theta_2(s)$ 

$$\theta_2(s) = \frac{\begin{vmatrix} (s^2 + 2s + 1) & T(s) \\ -(s + 1) & 0 \end{vmatrix}}{\begin{vmatrix} (s^2 + 2s + 1) & -(s + 1) \\ -(s + 1) & (2s + 1) \end{vmatrix}} = \frac{T(s)}{2s(s + 1)}$$

Hence,

$$\frac{\theta_2(s)}{T(s)} = \frac{1}{2s(s + 1)}$$

32.

Reflecting impedances to  $\theta_3$ ,

$$(J_{eq}s^2 + D_{eq}s)\theta_3(s) = T(s) \left( \frac{N_4 N_2}{N_3 N_1} \right)$$

Thus,

$$\frac{\theta_3(s)}{T(s)} = \frac{\frac{N_4 N_2}{N_3 N_1}}{J_{eq}s^2 + D_{eq}s}$$

where

$$J_{eq} = J_4 + J_5 + (J_2 + J_3) \left( \frac{N_4}{N_3} \right)^2 + J_1 \left( \frac{N_4 N_2}{N_3 N_1} \right)^2, \text{ and}$$

$$D_{eq} = (D_4 + D_5) + (D_2 + D_3) \left( \frac{N_4}{N_3} \right)^2 + D_1 \left( \frac{N_4 N_2}{N_3 N_1} \right)^2$$

**33.**

Reflecting all impedances to  $\theta_2(s)$ ,

$$\left\{ \left[ J_2 + J_1 \left( \frac{N_2}{N_1} \right)^2 + J_3 \left( \frac{N_3}{N_4} \right)^2 \right] s^2 + \left[ f_2 + f_1 \left( \frac{N_2}{N_1} \right)^2 + f_3 \left( \frac{N_3}{N_4} \right)^2 \right] s + \left[ K \left( \frac{N_3}{N_4} \right)^2 \right] \right\} \theta_2(s) = T(s) \frac{N_2}{N_1}$$

Substituting values,

$$\left\{ \left[ 1 + 2(3)^2 + 16 \left( \frac{1}{4} \right)^2 \right] s^2 + \left[ 2 + 1(3)^2 + 32 \left( \frac{1}{4} \right)^2 \right] s + 64 \left( \frac{1}{4} \right)^2 \right\} \theta_2(s) = T(s)(3)$$

Thus,

$$\frac{\theta_2(s)}{T(s)} = \frac{3}{20s^2 + 13s + 4}$$

**34.**

Reflecting impedances to  $\theta_2$ ,

$$\left[ 200 + 3 \left( \frac{50}{5} \right)^2 + 200 \left( \frac{5}{25} \times \frac{50}{5} \right)^2 \right] s^2 + \left[ 1000 \left( \frac{5}{25} \times \frac{50}{5} \right)^2 \right] s + \left[ 250 + 3 \left( \frac{50}{5} \right)^2 \right] = \left( \frac{50}{5} \right) T(s)$$

Thus,

$$\frac{\theta_2(s)}{T(s)} = \frac{10}{1300s^2 + 4000s + 550}$$

**35.**

Reflecting impedances and applied torque to respective sides of the spring yields the following equivalent circuit:

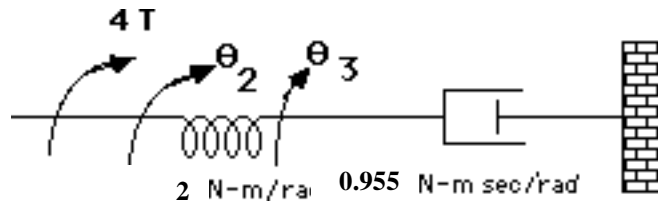

Writing the equations of motion,

$$2\theta_2(s) - 2\theta_3(s) = 4.231T(s)$$

$$-2\theta_2(s) + (0.955s + 2)\theta_3(s) = 0$$

Solving for  $\theta_3(s)$ ,

$$\theta_3(s) = \frac{\begin{vmatrix} 2 & 4.231T(s) \\ -2 & 0 \end{vmatrix}}{\begin{vmatrix} 2 & -2 \\ -2 & (0.955s + 2) \end{vmatrix}} = \frac{8.462T(s)}{1.91s} = \frac{4.43T(s)}{s}$$

Hence,  $\frac{\theta_3(s)}{T(s)} = \frac{4.43}{s}$ . But,  $\theta_4(s) = 0.192\theta_3(s)$ . Thus,  $\frac{\theta_4(s)}{T(s)} = \frac{0.851}{s}$ .

36.

Reflecting impedances and applied torque to respective sides of the viscous damper yields the following

equivalent circuit:

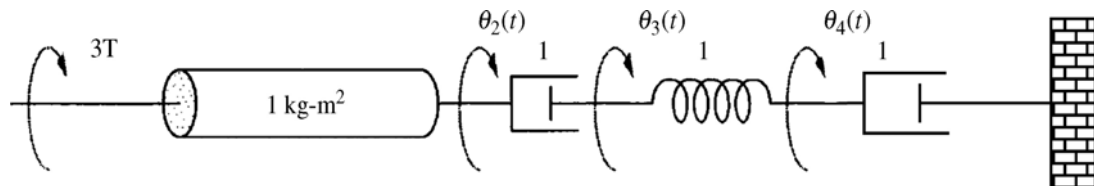

Writing the equations of motion,

$$(s^2 + 2s)\theta_2(s) - 2s\theta_3(s) = 3T(s)$$

$$-2s\theta_2(s) + (2s + 3)\theta_3(s) - 3\theta_4(s) = 0$$

$$-3\theta_3(s) + (s + 3)\theta_4(s) = 0$$

Solving for  $\theta_4(s)$ ,



$$\theta_4(s) = \frac{\begin{vmatrix} s(s+2) & -2s & 3T(s) \\ -2s & (2s+3) & 0 \\ 0 & -3 & 0 \end{vmatrix}}{\begin{vmatrix} s(s+2) & -2s & 0 \\ -2s & (2s+3) & -3 \\ 0 & -3 & (s+3) \end{vmatrix}} = \frac{18T(s)}{s(2s^2 + 9s + 6)}$$

But,  $\theta_L(s) = 5\theta_4(s)$ . Hence,

$$\frac{\theta_4(s)}{T(s)} = \frac{90}{s(2s^2 + 9s + 6)}$$

37. Reflect all impedances on the right to the viscous damper and reflect all impedances and torques on the left to the spring and obtain the following equivalent circuit:

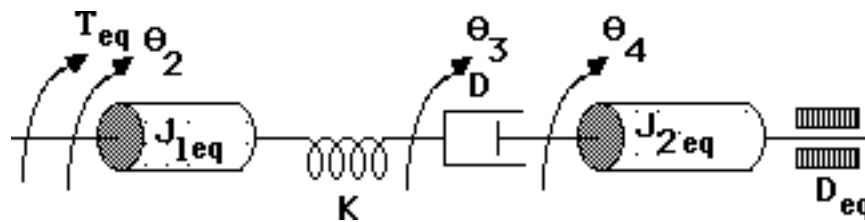

Writing the equations of motion,

$$(J_{1eq}s^2 + K)\theta_2(s) - K\theta_3(s) = T_{eq}(s)$$

$$-K\theta_2(s) + (Ds + K)\theta_3(s) - Ds\theta_4(s) = 0$$

$$-Ds\theta_3(s) + [J_{2eq}s^2 + (D + D_{eq})s]\theta_4(s) = 0$$

where:  $J_{1eq} = J_2 + (J_a + J_1)\left(\frac{N_2}{N_1}\right)^2$ ;  $J_{2eq} = J_3 + (J_L + J_4)\left(\frac{N_3}{N_4}\right)^2$ ;  $D_{eq} = D_L\left(\frac{N_3}{N_4}\right)^2$ ;  $\theta_2(s) = \theta_1(s)$

$$\frac{N_1}{N_2}$$

38.

Reflect impedances to the left of  $J_5$  to  $J_5$  and obtain the following equivalent circuit:

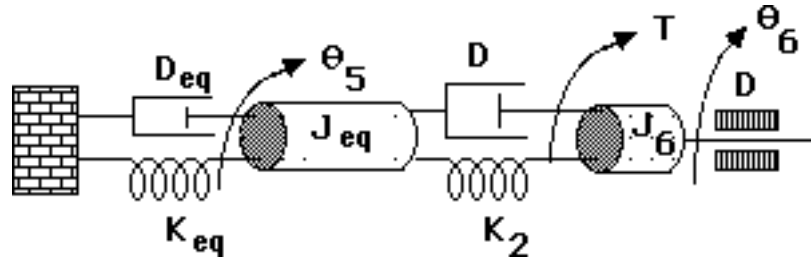

Writing the equations of motion,

$$[J_{eq}s^2 + (D_{eq} + D)s + (K_2 + K_{eq})]\theta_5(s) - [Ds + K_2]\theta_6(s) = 0$$

$$-[K_2 + Ds]\theta_5(s) + [J_6s^2 + 2Ds + K_2]\theta_6(s) = T(s)$$

From the first equation,  $\frac{\theta_6(s)}{\theta_5(s)} = \frac{J_{eq}s^2 + (D_{eq} + D)s + (K_2 + K_{eq})}{Ds + K_2}$ . But,  $\frac{\theta_5(s)}{\theta_1(s)} = \frac{N_1 N_3}{N_2 N_4}$ . Therefore,

$$\frac{\theta_6(s)}{\theta_1(s)} = \frac{N_1 N_3}{N_2 N_4} \left( \frac{J_{eq}s^2 + (D_{eq} + D)s + (K_2 + K_{eq})}{Ds + K_2} \right),$$

where  $J_{eq} = [J_1 \left(\frac{N_4 N_2}{N_3 N_1}\right)^2 + (J_2 + J_3) \left(\frac{N_4}{N_3}\right)^2 + (J_4 + J_5)]$ ,  $K_{eq} = K_1 \left(\frac{N_4}{N_3}\right)^2$ , and

$$D_{eq} = D \left[ \left(\frac{N_4 N_2}{N_3 N_1}\right)^2 + \left(\frac{N_4}{N_3}\right)^2 + 1 \right].$$

39.

Draw the freebody diagrams,

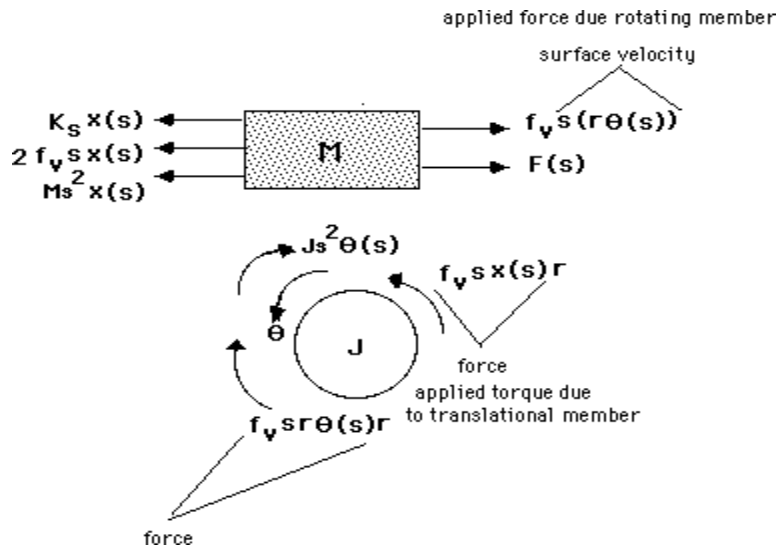

Write the equations of motion from the translational and rotational freebody diagrams,

$$(Ms^2 + 2f_v s + K_2)X(s) - f_v r \theta(s) = F(s)$$

$$-f_v r X(s) + (Js^2 + f_v r^2) \theta(s) = 0$$

Solve for  $\theta(s)$ ,

$$\theta(s) = \frac{\begin{vmatrix} Ms^2 + 2f_v s + K_2 & F(s) \\ -f_v r s & 0 \end{vmatrix}}{\begin{vmatrix} Ms^2 + 2f_v s + K_2 & -f_v r s \\ -f_v r s & Js^2 + f_v r^2 s \end{vmatrix}} = \frac{f_v r F(s)}{JMs^3 + (2Jf_v + Mf_v r^2)s^2 + (JK_2 + f_v^2 r^2)s + K_2 f_v r^2}$$

From which,  $\frac{\theta(s)}{F(s)} = \frac{f_v r}{JMs^3 + (2Jf_v + Mf_v r^2)s^2 + (JK_2 + f_v^2 r^2)s + K_2 f_v r^2}$ .

40.

Draw a freebody diagram of the translational system and the rotating member connected to the translational system.

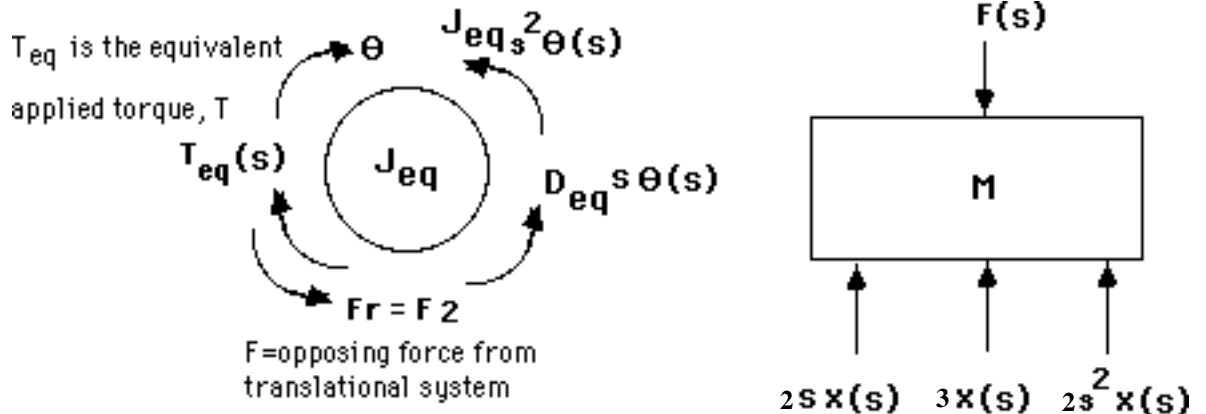

From the freebody diagram of the mass,  $F(s) = (2s^2 + 2s + 3)X(s)$ . Summing torques on the rotating member,

$(J_{eq}s^2 + D_{eq}s)\theta(s) + F(s)2 = T_{eq}(s)$ . Substituting  $F(s)$  above,  $(J_{eq}s^2 + D_{eq}s)\theta(s) + (4s^2 + 4s + 6)X(s) = T_{eq}(s)$ . However,  $\theta(s) = \frac{X(s)}{2}$ . Substituting and simplifying,

$$T_{eq} = \left[ \left( \frac{J_{eq}}{2} + 4 \right) s^2 + \left( \frac{D_{eq}}{2} + 4 \right) s + 6 \right] X(s)$$

But,  $J_{eq} = 3 + 3(4)^2 = 51$ ,  $D_{eq} = 1(2)^2 + 1 = 5$ , and  $T_{eq}(s) = 4T(s)$ . Therefore,

$$\left[ \frac{59}{2} s^2 + \frac{13}{2} s + 6 \right] X(s) = 4T(s). \text{ Finally, } \frac{X(s)}{T(s)} = \frac{8}{59s^2 + 13s + 12}.$$

41.

Writing the equations of motion,

$$\begin{aligned} (J_1 s^2 + K_1) \theta_1(s) - K_1 \theta_2(s) &= T(s) \\ -K_1 \theta_1(s) + (J_2 s^2 + D_3 s + K_1) \theta_2(s) + F(s)r - D_3 s \theta_3(s) &= 0 \\ -D_3 s \theta_2(s) + (J_2 s^2 + D_3 s) \theta_3(s) &= 0 \end{aligned}$$

where  $F(s)$  is the opposing force on  $J_2$  due to the translational member and  $r$  is the radius of  $J_2$ . But,

for the translational member,

$$F(s) = (Ms^2 + f_v s + K_2)X(s) = (Ms^2 + f_v s + K_2)r\theta(s)$$

Substituting  $F(s)$  back into the second equation of motion,

$$\begin{aligned} (J_1 s^2 + K_1) \theta_1(s) - K_1 \theta_2(s) &= T(s) \\ -K_1 \theta_1(s) + [(J_2 + Mr^2)s^2 + (D_3 + f_v r^2)s + (K_1 + K_2 r^2)] \theta_2(s) - D_3 s \theta_3(s) &= 0 \\ -D_3 s \theta_2(s) + (J_2 s^2 + D_3 s) \theta_3(s) &= 0 \end{aligned}$$

Notice that the translational components were reflected as equivalent rotational components by the

square of the radius. Solving for  $\theta_2(s)$ ,  $\theta_2(s) = \frac{K_1(J_3 s^2 + D_3 s)T(s)}{\Delta}$ , where  $\Delta$  is the

determinant formed from the coefficients of the three equations of motion. Hence,

$$\frac{\theta_2(s)}{T(s)} = \frac{K_1(J_3 s^2 + D_3 s)}{\Delta}$$

Since

$$X(s) = r\theta_2(s), \quad \frac{X(s)}{T(s)} = \frac{rK_1(J_3 s^2 + D_3 s)}{\Delta}$$

42.

$$\frac{K_t}{R_a} = \frac{T_{stall}}{E_a} = \frac{100}{50} = 2; \quad K_b = \frac{E_a}{\omega_{no-load}} = \frac{50}{150} = \frac{1}{3}$$

Also,

$$J_m = 5 + 18\left(\frac{1}{3}\right)^2 = 7; \quad D_m = 8 + 36\left(\frac{1}{3}\right)^2 = 12.$$

Thus,

$$\frac{\theta_m(s)}{E_a(s)} = \frac{2/7}{s(s + \frac{1}{7}(12 + \frac{2}{3}))} = \frac{2/7}{s(s + \frac{38}{21})}$$

$$\text{Since } \theta_L(s) = \frac{1}{3} \theta_m(s),$$

$$\frac{\theta_L(s)}{E_a(s)} = \frac{\frac{2}{21}}{s(s + \frac{38}{21})}$$

43. The parameters are:

$$\frac{K_t}{R_a} = \frac{T_s}{E_a} = \frac{5}{5} = 1; K_b = \frac{E_a}{\omega} = \frac{5}{\frac{600}{\pi} \frac{1}{60}} = \frac{1}{4}; J_m = 16\left(\frac{1}{4}\right)^2 + 4\left(\frac{1}{2}\right)^2 + 1 = 3; D_m = 32\left(\frac{1}{4}\right)^2 = 2$$

Thus,

$$\frac{\theta_m(s)}{E_a(s)} = \frac{\frac{1}{3}}{s(s + \frac{1}{3}(2 + (1)(\frac{1}{4})))} = \frac{\frac{1}{3}}{s(s + 0.75)}$$

Since  $\theta_2(s) = \frac{1}{4} \theta_m(s)$ ,

$$\frac{\theta_2(s)}{E_a(s)} = \frac{\frac{1}{12}}{s(s + 0.75)}$$

44. The following torque-speed curve can be drawn from the data given:

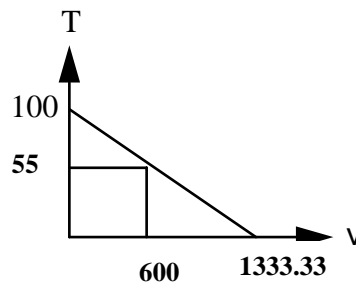

Therefore,  $\frac{K_t}{R_a} = \frac{T_{stall}}{E_a} = \frac{100}{12}$ ;  $K_b = \frac{E_a}{\omega_{no-load}} = \frac{12}{1333.33}$ . Also,  $J_m = 7 + 105\left(\frac{1}{6}\right)^2 = 9.92$ ;  $D_m =$

3. Thus,

$$\frac{\theta_m(s)}{E_a(s)} = \frac{\left(\frac{100}{12}\right) \frac{1}{9.92}}{s(s + \frac{1}{9.92}(3.075))} = \frac{0.84}{s(s + 0.31)}. \text{ Since } \theta_L(s) = \frac{1}{6} \theta_m(s), \frac{\theta_L(s)}{E_a(s)} = \frac{0.14}{s(s + 0.31)}$$

45. From Eqs. (2.45) and (2.46),

$$R_a I_a(s) + K_b s \theta(s) = E_a(s) \quad (1)$$

Also,

$T_m(s) = K_t I_a(s) = (J_m s^2 + D_m s) \theta(s)$ . Solving for  $\theta(s)$  and substituting into Eq. (1), and simplifying yields

$$\frac{I_a(s)}{E_a(s)} = \frac{1}{R_a} \frac{(s + \frac{D_m}{J_m})}{s + \frac{R_a D_m + K_b K_t}{R_a J_m}} \quad (2)$$

Using  $T_m(s) = K_t I_a(s)$  in Eq. (2),

$$\frac{T_m(s)}{E_a(s)} = \frac{K_t}{R_a} \frac{(s + \frac{D_m}{J_m})}{s + \frac{R_a D_m + K_b K_t}{R_a J_m}}$$

46. For the rotating load, assuming all inertia and damping has been reflected to the load,  $(J_{eqL} s^2 + D_{eqL} s) \theta_L(s) + F(s)r = T_{eq}(s)$ , where  $F(s)$  is the force from the translational system,  $r=2$  is the radius of the rotational member,  $J_{eqL}$  is the equivalent inertia at the load of the rotational load and the armature, and  $D_{eqL}$  is the equivalent damping at the load of the rotational load and the armature. Since  $J_{eqL} = 1(2)^2 + 1 = 5$ , and  $D_{eqL} = 1(2) + 1 = 5$ , the equation of motion becomes,  $(5s^2 + 5s) \theta_L(s) + F(s)r = T_{eq}(s)$ . For the translational system,  $(s^2 + s)X(s) = F(s)$ . Since  $X(s) = 2\theta_L(s)$ ,  $F(s) = (s^2 + s)2\theta_L(s)$ . Substituting  $F(s)$  into the rotational equation,  $(9s^2 + 9s) \theta_L(s) = T_{eq}(s)$ . Thus, the equivalent inertia at the load is 9, and the equivalent damping at the load is 9. Reflecting these back to the armature, yields an equivalent inertia of  $\frac{9}{4}$  and an equivalent damping of  $\frac{9}{4}$ . Finally,  $\frac{K_t}{R_a} = 1$ ;

$$K_b = 1. \text{ Hence, } \frac{\theta_m(s)}{E_a(s)} = \frac{\frac{4}{9}}{s + \frac{9}{4}} = \frac{\frac{4}{9}}{s + \frac{13}{9}}. \text{ Since } \theta_L(s) = \frac{1}{2} \theta_m(s), \frac{\theta_L(s)}{E_a(s)} = \frac{\frac{2}{9}}{s + \frac{13}{9}}. \text{ But}$$

$$X(s) = r\theta_L(s) = 2\theta_L(s). \text{ therefore, } \frac{X(s)}{E_a(s)} = \frac{\frac{4}{9}}{s + \frac{13}{9}}.$$

47.

The equations of motion in terms of velocity are:

$$\begin{aligned}
 & [M_1 s + (f_{v1} + f_{v3}) + \frac{K_1}{s} + \frac{K_2}{s}] V_1(s) - \frac{K_2}{s} V_2(s) - f_{v3} V_3(s) = 0 \\
 & -\frac{K_2}{s} V_1(s) + [M_2 s + (f_{v2} + f_{v4}) + \frac{K_2}{s}] V_2(s) - f_{v4} V_3(s) = F(s) \\
 & -f_{v3} V_1(s) - f_{v4} V_2(s) + [M_3 s + f_{v3} + f_{v4}] V_3(s) = 0
 \end{aligned}$$

For the series analogy, treating the equations of motion as mesh equations yields

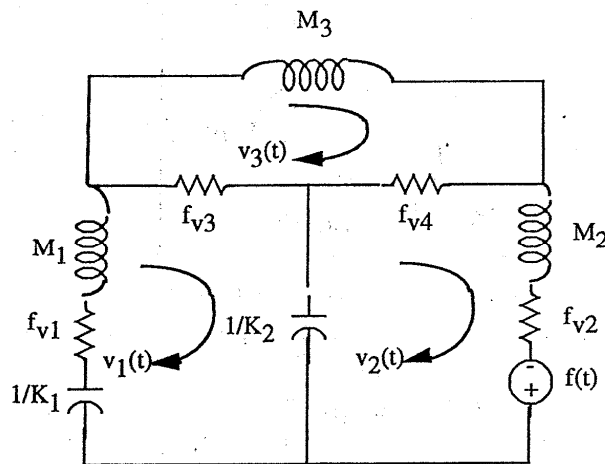

In the circuit, resistors are in ohms, capacitors are in farads, and inductors are in henries.

For the parallel analogy, treating the equations of motion as nodal equations yields

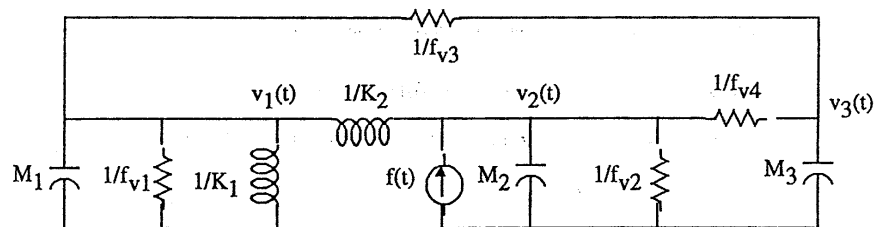

In the circuit, resistors are in ohms, capacitors are in farads, and inductors are in henries.

48.

Writing the equations of motion in terms of angular velocity,  $\Omega(s)$  yields

$$\begin{aligned}
 (J_1 s + D_1 + \frac{K_1}{s})\Omega_1(s) - (D_1 + \frac{K_1}{s})\Omega_2(s) &= T(s) \\
 -(D_1 + \frac{K_1}{s})\Omega_1(s) + (J_2 s + D_1 + \frac{K_1 + K_2}{s})\Omega_2(s) &= 0 \\
 -\frac{K_2}{s}\Omega_2(s) - D_2\Omega_3(s) + (D_2 + \frac{K_2}{s})\Omega_4(s) &= 0 \\
 (J_3 s + D_2 + \frac{K_3}{s})\Omega_3(s) - D_2\Omega_4(s) &= 0
 \end{aligned}$$

For the series analogy, treating the equations of motion as mesh equations yields

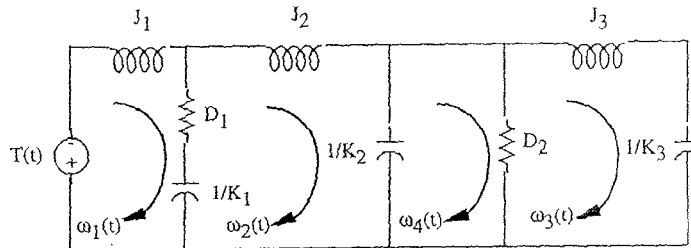

In the circuit, resistors are in ohms, capacitors are in farads, and inductors are in henries.

For the parallel analogy, treating the equations of motion as nodal equations yields

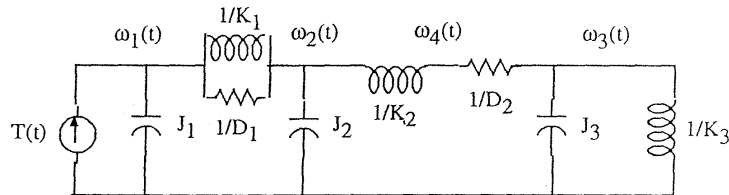

In the circuit, resistors are in ohms, capacitors are in farads, and inductors are in henries.

49. An input  $r_1$  yields  $c_1 = 5r_1 + 7$ . An input  $r_2$  yields  $c_2 = 5r_2 + 7$ . An input  $r_1 + r_2$  yields,  $5(r_1 + r_2) + 7 = 5r_1 + 7 + 5r_2 = c_1 + c_2 - 7$ . Therefore, not additive. What about homogeneity? An input of  $Kr_1$  yields  $c = 5Kr_1 + 7 \neq Kc_1$ . Therefore, not homogeneous. The system is not linear.
50. a. Let  $x = \delta x + 0$ . Therefore,



$$\ddot{\delta x} + 3\dot{\delta x} + 2\delta x = \sin(0 + \delta x)$$

But,  $\sin(0 + \delta x) = \sin 0 + \left. \frac{d \sin x}{dx} \right|_{x=0} \delta x = 0 + \cos x \Big|_{x=0} \delta x = \delta x$

Therefore,  $\ddot{\delta x} + 3\dot{\delta x} + 2\delta x = \delta x$ . Collecting terms,  $\ddot{\delta x} + 3\dot{\delta x} + \delta x = 0$ .

**b.** Let  $x = \delta x + \pi$ . Therefore,

$$\ddot{\delta x} + 3\dot{\delta x} + 2\delta x = \sin(\pi + \delta x)$$

But,  $\sin(\pi + \delta x) = \sin \pi + \left. \frac{d \sin x}{dx} \right|_{x=\pi} \delta x = 0 + \cos x \Big|_{x=\pi} \delta x = -\delta x$

Therefore,  $\ddot{\delta x} + 3\dot{\delta x} + 2\delta x = -\delta x$ . Collecting terms,  $\ddot{\delta x} + 3\dot{\delta x} + 3\delta x = 0$ .

**51.**

If  $x = 0 + \delta x$ ,

$$\ddot{\delta x} + 10\dot{\delta x} + 31\delta x + 30\delta x = e^{-(\delta x)}$$

But  $e^{-(\delta x)} = e^{-0} + \left. \frac{de^{-x}}{dx} \right|_{x=0} \delta x = 1 - e^{-x} \Big|_{x=0} \delta x = 1 - \delta x$

Therefore,  $\ddot{\delta x} + 10\dot{\delta x} + 31\delta x + 30\delta x = 1 - \delta x$ , or,  $\ddot{\delta x} + 10\dot{\delta x} + 31\delta x + 31\delta x = 1$ .

**52.**

The given curve can be described as follows:

$$f(x) = -6; -\infty < x < -3;$$

$$f(x) = 2x; -3 < x < 3;$$

$$f(x) = 6; 3 < x < +\infty$$

Thus,

a.  $\ddot{x} + 17\dot{x} + 50x = -6$

b.  $\ddot{x} + 17\dot{x} + 50x = 2x$  or  $\ddot{x} + 17\dot{x} + 48x = 0$

c.  $\ddot{x} + 17\dot{x} + 50x = 6$

**53.**

The relationship between the nonlinear spring's displacement,  $x_s(t)$  and its force,  $f_s(t)$  is

$$x_s(t) = 1 - e^{-f_s(t)}$$

Solving for the force,

$$f_s(t) = -\ln(1 - x_s(t)) \tag{1}$$

Writing the differential equation for the system by summing forces,

$$\frac{d^2 x(t)}{dt^2} + \frac{dx(t)}{dt} - \ln(1 - x(t)) = f(t) \tag{2}$$

Letting  $x(t) = x_0 + \delta x$  and  $f(t) = 1 + \delta f$ , linearize  $\ln(1 - x(t))$ .

$$\ln(1 - x) - \ln(1 - x_0) = \left. \frac{d \ln(1 - x)}{dx} \right|_{x=x_0} \delta x$$

Solving for  $\ln(1 - x)$ ,

$$\ln(1 - x) = \ln(1 - x_0) - \left. \frac{1}{1 - x} \right|_{x=x_0} \delta x = \ln(1 - x_0) - \frac{1}{1 - x_0} \delta x \quad (3)$$

When  $f = 1$ ,  $\delta x = 0$ . Thus from Eq. (1),  $1 = -\ln(1 - x_0)$ . Solving for  $x_0$ ,

$$1 - x_0 = e^{-1}, \text{ or } x_0 = 0.6321.$$

Substituting  $x_0 = 0.6321$  into Eq. (3),

$$\ln(1 - x) = \ln(1 - 0.6321) - \frac{1}{1 - 0.6321} \delta x = -1 - 2.718 \delta x$$

Placing this value into Eq. (2) along with  $x(t) = x_0 + \delta x$  and  $f(t) = 1 + \delta f$ , yields the linearized differential equation,

$$\frac{d^2 \delta x}{dt^2} + \frac{d \delta x}{dt} + 1 + 2.718 \delta x = 1 + \delta f$$

or

$$\frac{d^2 \delta x}{dt^2} + \frac{d \delta x}{dt} + 2.718 \delta x = \delta f$$

Taking the Laplace transform and rearranging yields the transfer function,

$$\frac{\delta x(s)}{\delta f(s)} = \frac{1}{s^2 + s + 2.718}$$

#### 54.

First assume there are  $n$  plates without the top plate positioned at a displacement of  $y_2(t)$  where  $y_2(t) = 0$  is the position of the unstretched spring. Assume the system consists of mass  $M$ , where  $M$  is the mass of the dispensing system and the  $n$  plates, viscous friction,  $f_v$ , where the viscous friction originates where the piston meets the sides of the cylinder, and of course the spring with spring constant,  $K$ . Now, draw the freebody diagram shown in Figure (b) where  $W_n$  is the total weight of the  $n$  dishes and the piston. If we now consider the current position,  $y_2(0)$ ,

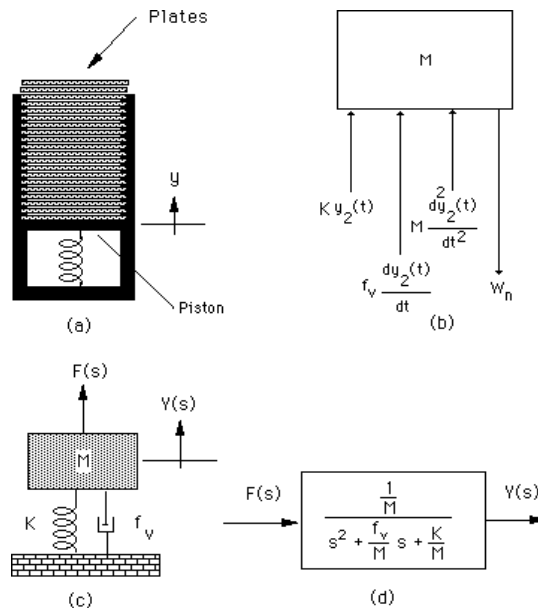

### Restaurant Plate Dispenser

the equilibrium point and define a new displacement,  $y_1(t)$ , which is measured from equilibrium, we can write the force in the spring as  $Ky_2(t) = Ky_2(0) + Ky_1(t)$ . Changing variables from  $y_2(t)$  to  $y_1(t)$ , we sum forces and get,

$$M \frac{d^2 y_1}{dt^2} + f_v \frac{dy_1}{dt} + Ky_1 + Ky_2(0) + W_n = 0 \tag{1}$$

where  $\frac{d^2 y_2}{dt^2} = \frac{d^2 y_1}{dt^2}$  and  $\frac{dy_2}{dt} = \frac{dy_1}{dt}$ . But,  $Ky_2(0) = -W_n$ , since it is the component of the spring force that balances the weight at equilibrium when  $y_1 = 0$ . Thus, the differential equation becomes,

$$M \frac{d^2 y_1}{dt^2} + f_v \frac{dy_1}{dt} + Ky_1 = 0 \tag{2}$$

When the top plate is added, the spring is further compressed by an amount,  $\frac{W_D}{K}$ , where  $W_D$  is the weight of the single dish, and  $K$  is the spring constant. We can think of this displacement as an initial condition. Thus,  $y_1(0^-) = -\frac{W_D}{K}$  and  $\frac{dy_1}{dt}(0^-) = 0$ , and  $y_1(t) = 0$  is the equilibrium position of the spring with  $n$  plates rather than the unstretched position. Taking the Laplace transform of equation (2), using the initial conditions,

$$M(s^2 Y_1(s) + s \frac{W_D}{K}) + f_v(s Y_1(s) + \frac{W_D}{K}) + K Y_1(s) = 0 \quad (3)$$

or

$$(Ms^2 + f_v s + K) Y_1(s) = -\frac{W_D}{K} (Ms + f_v) \quad (4)$$

Now define a new position reference,  $Y(s)$ , which is zero when the spring is compressed with the initial condition,

$$Y(s) = Y_1(s) + \frac{W_D}{Ks} \quad (5)$$

or

$$Y_1(s) = Y(s) - \frac{W_D}{Ks} \quad (6)$$

Substituting  $Y_1(s)$  in Equation (4), we obtain,

$$(Ms^2 + f_v s + K) Y(s) = \frac{W_D}{s} = F(s) \quad (7)$$

a differential equation that has an input and zero initial conditions. The schematic is shown in Figure (c). Forming the transfer function,  $\frac{Y(s)}{F(s)}$ , we show the final result in Figure (d), where for the removal of the top plate,  $F(s)$  is always a step,  $F(s) = \frac{W_D}{s}$ .

**55.**

$$\text{We have } J\ddot{\phi} + b\dot{\phi} + k\phi = (aJ)\ddot{\psi}$$

Assuming zero initial conditions and obtaining Laplace transform on both sides of the equation we obtain:

$$Js^2 \Phi(s) + bs\Phi(s) + k\Phi(s) = (aJ)\ddot{\Psi}(s)$$

From which we get:

$$\frac{\Phi(s)}{\ddot{\Psi}(s)} = \frac{aJ}{Js^2 + bs + k}$$

**56.**

a. We choose Laplace transforms to obtain a solution. After substitution of numerical values the equations become:

$$\begin{aligned} \frac{dC(t)}{dt} &= -0.9C(t) + 0.7N(t) \\ \frac{dN(t)}{dt} &= -0.1C(t) - 0.02N(t) + I(t) \end{aligned}$$

Obtaining Laplace transforms and substituting initial values we obtain:

$$sC(s) - 47000500 = -0.9C(s) + 0.7N(s)$$

$$sN(s) - 61100500 = -0.1C(s) - 0.02N(s) + I(s)$$

Both equations are manipulated as follows:

$$C(s) = \frac{0.7N(s)}{s + 0.9} + \frac{47000500}{s + 0.9}$$

$$N(s) = \frac{-0.1C(s)}{s + 0.02} + \frac{61100500}{s + 0.02} + \frac{I(s)}{s + 0.02}$$

Substituting the first equation into the second one gets:

$$N(s) = \frac{-\frac{47000500}{(s + 0.02)(s + 0.9)} + \frac{61100500}{s + 0.02} + \frac{I(s)}{s + 0.02}}{1 + \frac{0.07}{(s + 0.02)(s + 0.9)}} = \frac{-\frac{47000500}{(s + 0.02)(s + 0.9)} + \frac{61100500}{s + 0.02} + \frac{I(s)}{s + 0.02}}{\frac{s^2 + 0.92s + 0.088}{(s + 0.02)(s + 0.9)}}$$

$$= \frac{s + 0.9}{s^2 + 0.92s + 0.088} I(s) + \frac{61100500(s + 0.9)}{s^2 + 0.92s + 0.088} - \frac{47000500}{s^2 + 0.92s + 0.088}$$

From which we get the block diagram:

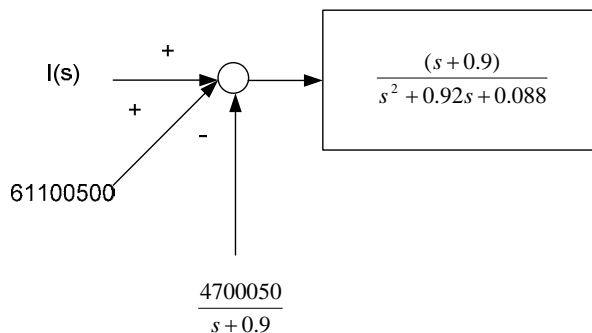

b. Letting  $I(s) = \frac{6 \times 10^6}{s}$  and after algebraic manipulations one gets:

$$N(s) = \frac{61100500s^2 + 56290400s + 54 \times 10^5}{s(s^2 + 0.92s + 0.088)} = \frac{61100500s^2 + 56290400s + 54 \times 10^5}{s(s + 0.8116)(s + 0.1084)}$$

$$= \frac{A}{s} + \frac{B}{s + 0.8116} + \frac{C}{s + 0.1084} = \frac{6.1354 \times 10^7}{s} - \frac{7 \times 10^4}{s + 0.8116} - \frac{19.3 \times 10^4}{s + 0.1084}$$

Obtaining the inverse Laplace transform:

$$N(t) = 6.1364 \times 10^7 - 7 \times 10^4 e^{-0.8116t} - 19.3 \times 10^4 e^{-0.1084t}$$

57.

a.

'Exact':

From Figure (a)

$$V_o(s) = \frac{\frac{1}{8}}{s + \frac{1}{8}} V_{in}(s) = \frac{\frac{1}{8}}{s + \frac{1}{8}} \frac{3(1 - e^{-0.005s})}{s} = \frac{3}{8} \frac{(1 - e^{-0.005s})}{s \left( s + \frac{1}{8} \right)}$$

Using Partial fraction expansions note that  $\frac{1}{s(s+1)} = \frac{1}{s} - \frac{1}{s+1}$ . Thus, applying partial fraction

expansion to  $V_o(s)$  and taking the inverse Laplace transform yields,

$$\text{So } v_o(t) = 3(1 - e^{-\frac{1}{8}t})u(t) - 3(1 - e^{-\frac{1}{8}(t-0.005)})u(t-0.005)$$

'Impulse':

$$V_o(s) = \frac{\frac{1}{8}}{s + \frac{1}{8}} V_{in}(s) = \frac{\frac{1}{8}}{s + \frac{1}{8}} 0.015 = \frac{0.001875}{s + 0.125}$$

In this case  $v_o(t) = 0.001875e^{-0.125t}$

b.

The following M-File will simulate both inputs:

```
syms s
s = tf('s');
G=(1/8)/(s+(1/8));
t=0:1e-4:10;
for i=1:max(size(t)),
    if(i*1e-4 <= 5e-3)
        vinexact(i) = 3;
    else
        vinexact(i) = 0;
    end
end
yexact = lsim(G,vinexact,t);
yimpulse = 0.001875*exp(-(1/8)*t);
plot(t,yexact,t,yimpulse)
```

Resulting in the following figure:

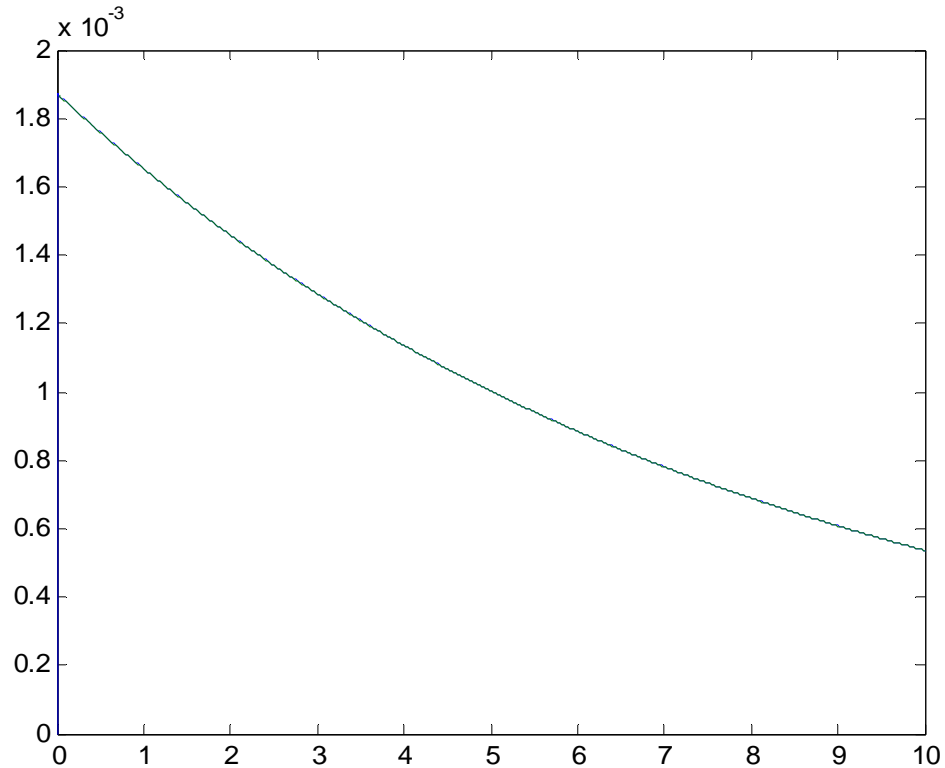

Both outputs are indistinguishable at this scale. However zooming closer to t=0 will show differences.

58.

a. At equilibrium

$$\frac{d^2 H}{dt^2} = 0. \text{ From which we get that } mg = k \frac{I^2}{H^2} \text{ or } H_0 = I_0 \sqrt{\frac{k}{mg}}$$

b. Following the 'hint' procedure:

$$m \frac{d^2 \delta H}{dt^2} = k \frac{2(I_0 + \delta I)^2 (H_0 + \delta H)}{(H_0 + \delta H)^4} \Big|_{\delta H=0, \delta I=0} \delta H - k \frac{2(I_0 + \delta I) (H_0 + \delta H)^2}{(H_0 + \delta H)^4} \Big|_{\delta H=0, \delta I=0} \delta I$$

After some algebraic manipulations this becomes:

$$m \frac{d^2 \delta H}{dt^2} = \frac{2kI_0^2}{mH_0^3} \delta H - \frac{2kI_0}{mH_0^2} \delta I$$

Obtaining Laplace transform on both sides of the equation one obtains the transfer function:

$$\frac{\delta H(s)}{\delta I(s)} = -\frac{\frac{2kI_0}{mH_0^2}}{s^2 - \frac{2kI_0^2}{mH_0^3}}$$

59.

The two differential equations for this system are:

$$M_b \ddot{x}_s + K_a(x_s - x_w) + C_a(\dot{x}_s - \dot{x}_w) = 0$$

$$M_{us} \ddot{x}_w + K_a(x_w - x_s) + C_a(\dot{x}_w - \dot{x}_s) + K_t(x_w - r) = 0$$

Obtaining Laplace transform on both sides gives

$$(M_b s^2 + C_a s + K_a)X_s - (K_a + C_a s)X_w = 0$$

$$(M_{us} s^2 + C_a s + (K_a + K_t))X_w - (K_a + C_a s)X_s = RK_t$$

Solving the first equation for  $X_s$  and substituting into the second one gets

$$\frac{X_w}{R}(s) = \frac{K_t(M_b s^2 + C_a s + K_a)}{(M_{us} s^2 + C_a s + (K_a + K_t))(M_b s^2 + C_a s + K_a) - (K_a + C_a s)^2}$$

60.

a. The three equations are transformed into the Laplace domain:

$$Ss - S_0 = k_\psi \tilde{K}_S C - k_\psi S$$

$$Cs = k_\psi (S - \tilde{K}_M C)$$

$$Ps = k_2 C$$

The three equations are algebraically manipulated to give:

$$S = \frac{S_0}{s + k_\psi} + \frac{k_\psi \tilde{K}_S}{s + k_\psi} C$$

$$C = \frac{Sk_\psi}{s + k_\psi \tilde{K}_M}$$

$$P = \frac{k_2}{s} C$$

By direct substitutions it is obtained that:



$$S = \frac{(s + k_\psi \tilde{K}_M)}{s^2 + k_\psi(1 + \tilde{K}_M)s + k^2_\psi(\tilde{K}_M - \tilde{K}_S)} S_0$$

$$C = \frac{k_\psi}{(s^2 + k_\psi(1 + \tilde{K}_M)s + k^2_\psi(\tilde{K}_M - \tilde{K}_S))} S_0$$

$$P = \frac{k_2 k_\psi}{s(s^2 + k_\psi(1 + \tilde{K}_M)s + k^2_\psi(\tilde{K}_M - \tilde{K}_S))} S_0$$

b.

$$S(\infty) = \lim_{s \rightarrow 0} sS(s) = 0$$

$$C(\infty) = \lim_{s \rightarrow 0} sC(s) = 0$$

$$P(\infty) = \lim_{s \rightarrow 0} sP(s) = \frac{k_2 k_\psi S_0}{k^2_\psi(\tilde{K}_M - \tilde{K}_S)} = \frac{k_2 S_0}{k_\psi(\tilde{K}_S + \frac{k_2}{k_\psi} - \tilde{K}_S)} = S_0$$

61.

Eliminate  $T_{bal}$  by direct substitution. This results in

$$J \frac{d^2 \theta}{dt^2} = -kJ\theta(t) - \eta J \dot{\theta}(t) - \rho J \int_0^t \theta(t) dt + T_d(t)$$

Obtaining Laplace transform on both sides of this equation and eliminating terms one gets that:

$$\frac{\Theta}{T_d}(s) = \frac{\frac{1}{J} s}{s^3 + \eta s^2 + ks + \rho}$$

62.

a.

We have that

$$m_L \ddot{x}_{La} = m_L g \phi$$

$$x_{La} = x_T - x_L$$

$$x_L = L\phi$$

From the second equation

$$\ddot{x}_{La} = \ddot{x}_T - \ddot{x}_L = \dot{v}_T - L\ddot{\phi} = g\phi$$

Obtaining Laplace transforms on both sides of the previous equation

$$sV_T - Ls\Phi = g\Phi \text{ from which } sV_T = \Phi(g + Ls^2)$$

so that

$$\frac{\Phi}{V_T}(s) = \frac{s}{g + Ls^2} = \frac{1}{L} \frac{s}{s^2 + \frac{g}{L}} = \frac{1}{L} \frac{s}{s^2 + \omega_0^2}$$

**b.** Under constant velocity  $V_T(s) = \frac{V_0}{s}$  so the angle is

$$\Phi(s) = \frac{V_0}{L} \frac{1}{s^2 + \omega_0^2}$$

Obtaining inverse Laplace transform

$$\phi(t) = \frac{V_0}{L\omega_0} \sin(\omega_0 t), \text{ the load will sway with a frequency } \omega_0 .$$

**c.** From  $m_T \ddot{x}_T - f_T - m_L g \phi$  and Laplace transformation we get

$$m_T s^2 X_T(s) = F_T - m_L g \Phi(s) = F_T - m_L g \frac{1}{L} \frac{s}{s^2 + \omega_0^2} V_T = F_T - m_L g \frac{1}{L} \frac{s^2}{s^2 + \omega_0^2} X_T$$

From which

$$\frac{X_T}{F_T} = \frac{1}{s^2(m_T + \frac{m_L g}{L} \frac{1}{s^2 + \omega_0^2})} = \frac{s^2 + \omega_0^2}{s^2(m_T(s^2 + \omega_0^2) + m_L \omega_0^2)} = \frac{1}{m_T} \frac{s^2 + \omega_0^2}{s^2(s^2 + a\omega_0^2)}$$

$$\text{Where } a = 1 + \frac{m_L}{m_T}$$

**d.** From part c

$$\frac{V_T}{F_T} = \frac{sX_T}{F_T} = \frac{1}{m_T} \frac{s^2 + \omega_0^2}{s(s^2 + a\omega_0^2)}$$

$$\text{Let } F_T = \frac{F_0}{s} \text{ then}$$

$$V_T(s) = \frac{F_0}{m_T} \frac{s^2 + \omega_0^2}{s^2(s^2 + a\omega_0^2)} = \frac{A}{s^2} + \frac{B}{s} + \frac{Cs + D}{s^2 + a\omega_0^2}$$

After partial fraction expansions, so

$$v_T(t) = A't + B + C' \cos(a\omega_0 t + \theta)$$

From which it is clear that  $v_T \xrightarrow{t \rightarrow \infty} \infty$

63.

a. Obtaining Laplace transforms on both sides of the equation

$$sN(s) - N_0 = KN(s) \text{ or } N(s) = \frac{N_0}{s - K}$$

By inverse Laplace transformation

$$N(t) = N_0 e^{Kt}$$

b. Want to find the time at which

$$N_0 e^{Kt} = 2N_0$$

Obtaining ln on both sides of the equation

$$t = \frac{\ln 2}{K}$$

64.

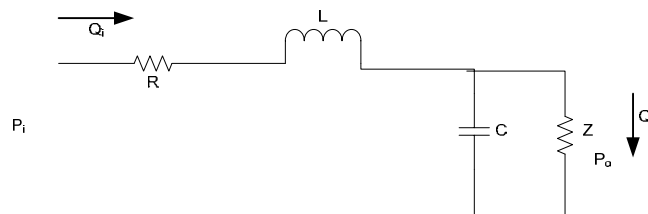

a. Converting each one of the impedances to its Laplace transform equivalent and applying the voltage divider rule one gets

$$Z \parallel \frac{1}{sC} = \frac{\frac{Z}{sC}}{Z + \frac{1}{sC}} = \frac{\frac{1}{C}}{s + \frac{1}{ZC}}$$

$$\frac{P_o}{P_i}(s) = \frac{\frac{\frac{1}{C}}{s + \frac{1}{ZC}}}{R + sL + \frac{\frac{1}{C}}{s + \frac{1}{ZC}}} = \frac{\frac{1}{LC}}{s^2 + \left(\frac{R}{L} + \frac{1}{ZC}\right)s + \left(\frac{R}{ZCL} + \frac{1}{CL}\right)}$$

Since  $Q_0 = \frac{P_o}{Z}$ ,

$$\frac{Q_o}{P_i}(s) = \frac{\frac{1}{LCZ}}{s^2 + \left(\frac{R}{L} + \frac{1}{ZC}\right)s + \left(\frac{R}{ZCL} + \frac{1}{CL}\right)} = \frac{0.0236}{s^2 + 33.0125s + 73559}$$

b. The steady state circuit becomes

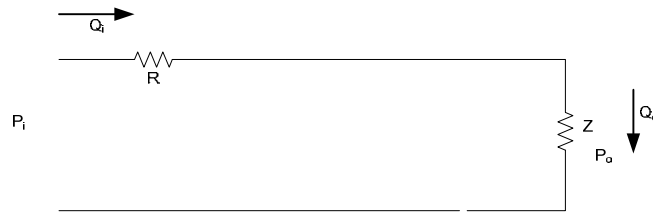

So that  $Q_0 = \frac{P_i}{R + Z} = \frac{1}{4176 + 308163} = 3.2 \times 10^{-6}$

c. Applying the final value theorem

$$q_o(\infty) = \lim_{s \rightarrow 0} s \frac{0.0236}{s^2 + 33.0125s + 73559} \frac{1}{s} = 3.2 \times 10^{-6}$$

65. The laplace transform of the systems output is

$$\mathcal{L}\{T(t)\} = T(s) = \frac{T_{ref}}{s} - \frac{T_{ref}}{s + \lambda} + \frac{2a\pi f}{s^2 + 4\pi^2 f^2} = \frac{T_{ref}\lambda}{s(s + \lambda)} + \frac{2a\pi f}{s^2 + 4\pi^2 f^2}$$

Dividing by the input one gets

$$\frac{T}{U}(s) = \frac{\lambda}{s + \lambda} + \frac{2a\pi f}{T_{ref}} \frac{s}{s^2 + 4\pi^2 f^2}$$

66.

a. By direct differentiation  $\frac{dV(t)}{dt} = V_0 \frac{\lambda}{\alpha} (\alpha e^{-\alpha t}) e^{\frac{\lambda}{\alpha}(1-e^{-\alpha t})} = \lambda e^{-\alpha t} V(t)$

b.  $V(\infty) = \lim_{t \rightarrow \infty} V(t) = \lim_{t \rightarrow \infty} V_0 e^{\frac{\lambda}{\alpha}(1-e^{-\alpha t})} = V_0 e^{\frac{\lambda}{\alpha}}$

c.

```

Lambda = 2.5;
alpha = 0.1;
V0=50;
t=linspace(0,100);
V=V0.*exp(Lambda.*(1-exp(-alpha.*t))/alpha);
plot(t,V)
grid
xlabel('t (days)')
ylabel('mm^3 X 10^-3')
    
```

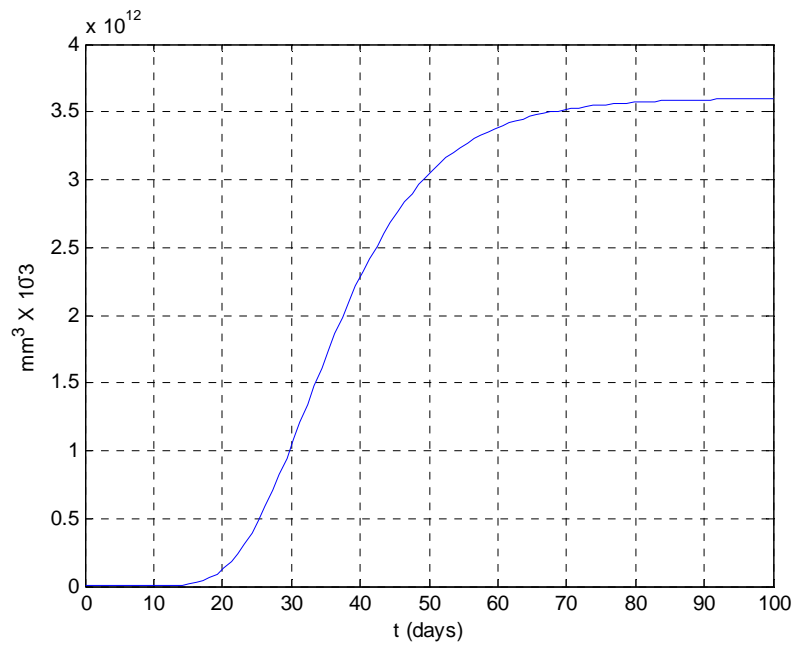

d. From the figure  $V(\infty) \approx 3.5 \times 10^{12} \text{ mm}^3 \times 10^{-3}$

From part c  $V(\infty) = V_0 e^{\frac{\lambda}{\alpha}} = 50 e^{\frac{2.5}{0.1}} = 3.6 \times 10^{12} \text{ mm}^3 \times 10^{-3}$

67.

Writing the equations of motion,

$$\begin{aligned}
 (17.2s^2 + 160s + 7000)Y_f(s) & \quad - (130s + 7000)Y_h(s) & \quad - 0Y_{cat}(s) = F_{up}(s) \\
 - (130s+7000)Y_f(s) & \quad + (9.1s^s + 130s + 89300)Y_h(s) & \quad - 82300Y_{cat}(s) = 0
 \end{aligned}$$

$$-0Y_t(s) - 82300Y_h(s) + 1.6173 \times 10^6 Y_{cat}(s) = 0$$

These equations are in the form  $\mathbf{AY}=\mathbf{F}$ , where  $\det(\mathbf{A}) = 2.5314 \times 10^8 (s^2 + 15.47s + 9283)(s^2 + 8.119s + 376.3)$

Using Cramer's rule:

$$\frac{Y_{cat}(s)}{F_{up}(s)} = \frac{0.04227(s + 53.85)}{(s^2 + 15.47s + 9283)(s^2 + 8.119s + 376.3)}$$

$$\frac{Y_h(s)}{F_{up}(s)} = \frac{0.8306(s + 53.85)}{(s^2 + 15.47s + 9283)(s^2 + 8.119s + 376.3)}$$

$$\frac{Y_h(s) - Y_{cat}(s)}{F_{up}(s)} = \frac{0.7883(s + 53.85)}{(s^2 + 15.47s + 9283)(s^2 + 8.119s + 376.3)}$$

68.

a. The first two equations are nonlinear because of the  $Tv$  products on their right hand side. Otherwise the equations are linear.

b. To find the equilibria let  $\frac{dT}{dt} = \frac{dT^*}{dt} = \frac{dv}{dt} = 0$

Leading to

$$s - dT - \beta Tv = 0$$

$$\beta Tv - \mu T^* = 0$$

$$kT^* - cv = 0$$

The first equilibrium is found by direct substitution. For the second equilibrium, solve the last two equations for  $T^*$

$$T^* = \frac{\beta Tv}{\mu} \text{ and } T^* = \frac{cv}{k}. \text{ Equating we get that } T = \frac{c\mu}{\beta k}$$

Substituting the latter into the first equation after some algebraic manipulations we get that  $v = \frac{ks}{c\mu} - \frac{d}{\beta}$ . It follows that  $T^* = \frac{cv}{k} = \frac{s}{\mu} - \frac{cd}{k\beta}$ .

69.

a. From  $a = \frac{F - F_w}{k_m \cdot m}$ , we have:  $F = F_w + k_m \cdot m \cdot a = F_{Ro} + F_L + F_{St} + k_m \cdot m \cdot a$  (1)

Substituting for the motive force,  $F$ , and the resistances  $F_{Ro}$ ,  $F_L$ , and  $F_{st}$  using the equations given in the problem, yields the equation:

$$F = \frac{P \cdot \eta_{tot}}{v} = f \cdot m \cdot g \cdot \cos \alpha + m \cdot g \cdot \sin \alpha + 0.5 \cdot \rho \cdot C_w \cdot A \cdot (v + v_{hw})^2 + k_m \cdot m \cdot a \quad (2)$$

- b. Noting that constant acceleration is assumed, the average values for speed and acceleration are:

$$a_{av} = 20 \text{ (km/h)} / 4 \text{ s} = 5 \text{ km/h.s} = 5 \times 1000 / 3600 \text{ m/s}^2 = 1.389 \text{ m/s}^2$$

$$v_{av} = 50 \text{ km/h} = 50,000 / 3,600 \text{ m/s} = 13.89 \text{ m/s}$$

The motive force,  $F$  (in N), and power,  $P$  (in kW) can be found from eq. 2:

$$F_{av} = 0.011 \times 1590 \times 9.8 + 0.5 \times 1.2 \times 0.3 \times 2 \times 13.89^2 + 1.2 \times 1590 \times 1.389 = 2891 \text{ N}$$

$$P_{av} = F_{av} \cdot v / \eta_{tot} = 2891 \times 13.89 / 0.9 = 44,617 \text{ N.m/s} = 44.62 \text{ kW}$$

To maintain a speed of 60 km/h while climbing a hill with a gradient  $\alpha = 5^\circ$ , the car engine or motor needs to overcome the climbing resistance:

$$F_{St} = m \cdot g \cdot \sin \alpha = 1590 \cdot 9.8 \cdot \sin 5^\circ = 1358 \text{ N}$$

Thus, the additional power,  $P_{add}$ , the car needs after reaching 60 km/h to maintain its speed while climbing a hill with a gradient  $\alpha = 5^\circ$  is:

$$P_{add} = F_{St} \cdot v / \eta = 1358 \times 60 \times 1000 / (3,600 \times 0.9) = 25,149 \text{ W} = 25.15 \text{ kW}$$

- c. Substituting for the car parameters into equation 2 yields:

$$F = 0.011 \times 1590 \times 9.8 + 0.5 \times 1.2 \times 0.3 \times 2 \times v^2 + 1.2 \times 1590 \text{ dv/dt}$$

$$\text{or } F(t) = 171.4 + 0.36 v^2 + 1908 \text{ dv/dt} \quad (3)$$

To linearize this equation about  $v_o = 50 \text{ km/h} = 13.89 \text{ m/s}$ , we use the truncated Taylor series:

$$v^2 - v_o^2 \approx \frac{d(v^2)}{dv} \Big|_{v=v_o} (v - v_o) = 2v_o \cdot (v - v_o) \quad (4), \text{ from which we obtain:}$$

$$v^2 = 2v_o \cdot v - v_o^2 = 27.78 \cdot v - 13.89^2 \quad (5)$$

Substituting from equation (5) into (3) yields:

$$F(t) = 171.4 + 10v - 69.46 + 1908 \, dv/dt \quad \text{or}$$

$$F_e(t) = F(t) - F_{Ro} + F_o = F(t) - 171.4 + 69.46 = 10v + 1908 \, dv/dt \quad (6)$$

Equation (6) may be represented by the following block-diagram:

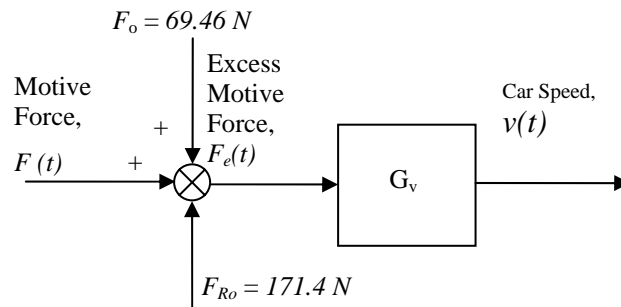

- d. Taking the Laplace transform of the left and right-hand sides of equation (6) gives,

$$F_e(s) = 10V(s) + 1908 \, sV(s) \quad (7)$$

Thus the transfer function,  $G_v(s)$ , relating car speed,  $V(s)$  to the excess motive force,  $F_e(s)$ , when the

car is at speeds around  $v_o = 50 \text{ km/h} = 13.89 \text{ m/s}$  under windless conditions is:

$$G_v(s) = \frac{V(s)}{F_e(s)} = \frac{1}{10 + 1908 \, s} \quad (8)$$



# T H R E E

## Modeling in the Time Domain

### SOLUTIONS TO CASE STUDIES CHALLENGES

#### Antenna Control: State-Space Representation

For the power amplifier,  $\frac{E_a(s)}{V_p(s)} = \frac{150}{s+150}$ . Taking the inverse Laplace transform,  $\dot{e}_a + 150e_a = 150v_p$ . Thus, the state equation is

$$\dot{e}_a = -150e_a + 150v_p$$

For the motor and load, define the state variables as  $x_1 = \theta_m$  and  $x_2 = \dot{\theta}_m$ . Therefore,

$$\dot{x}_1 = x_2 \quad (1)$$

Using the transfer function of the motor, cross multiplying, taking the inverse Laplace transform, and using the definitions for the state variables,

$$\dot{x}_2 = -\frac{1}{J_m} \left( D_m + \frac{K_t K_a}{R_a} \right) x_2 + \frac{K_t}{R_a J_m} e_a \quad (2)$$

Using the gear ratio, the output equation is

$$y = 0.2x_1 \quad (3)$$

Also,  $J_m = J_a + 5\left(\frac{1}{5}\right)^2 = 0.05 + 0.2 = 0.25$ ,  $D_m = D_a + 3\left(\frac{1}{5}\right)^2 = 0.01 + 0.12 = 0.13$ ,  $\frac{K_t}{R_a J_m} = \frac{1}{(5)(0.25)}$

$= 0.8$ , and  $\frac{1}{J_m} \left( D_m + \frac{K_t K_a}{R_a} \right) = 1.32$ . Using Eqs. (1), (2), and (3) along with the previous values, the

state and output equations are,

$$\dot{\mathbf{x}} = \begin{bmatrix} 0 & 1 \\ 0 & -1.32 \end{bmatrix} \mathbf{x} + \begin{bmatrix} 0 \\ 0.8 \end{bmatrix} e_a ; y = [0.2 \quad 0] \mathbf{x}$$

**Aquifer: State-Space Representation**

$$C_1 \frac{dh_1}{dt} = q_{i1} - q_{o1} + q_2 - q_1 + q_{21} = q_{i1} - 0 + G_2(h_2 - h_1) - G_1 h_1 + G_{21}(H_1 - h_1) =$$

$$-(G_2 + G_1 + G_{21})h_1 + G_2 h_2 + q_{i1} + G_{21}H_1$$

$$C_2 \frac{dh_2}{dt} = q_{i2} - q_{o2} + q_3 - q_2 + q_{32} = q_{i2} - q_{o2} + G_3(h_3 - h_2) - G_2(h_2 - h_1) + 0 = G_2 h_1 - [G_2 + G_3]h_2 + G_3 h_3 + q_{i2} - q_{o2}$$

$$C_3 \frac{dh_3}{dt} = q_{i3} - q_{o3} + q_4 - q_3 + q_{43} = q_{i3} - q_{o3} + 0 - G_3(h_3 - h_2) + 0 = G_3 h_2 - G_3 h_3 + q_{i3} - q_{o3}$$

Dividing each equation by  $C_i$  and defining the state vector as  $\mathbf{x} = [h_1 \ h_2 \ h_3]^T$

$$\dot{\mathbf{x}} = \begin{bmatrix} \frac{-(G_1 + G_2 + G_3)}{C_1} & \frac{G_2}{C_1} & 0 \\ \frac{G_2}{C_2} & \frac{-(G_2 + G_3)}{C_2} & \frac{G_3}{C_2} \\ 0 & \frac{G_3}{C_3} & \frac{-G_3}{C_3} \end{bmatrix} \mathbf{x} + \begin{bmatrix} \frac{q_{i1} + G_{21}H_1}{C_1} \\ \frac{q_{i2} - q_{o2}}{C_2} \\ \frac{q_{i3} - q_{o3}}{C_3} \end{bmatrix} u(t)$$

$$\mathbf{y} = \begin{bmatrix} 1 & 0 & 0 \\ 0 & 1 & 0 \\ 0 & 0 & 1 \end{bmatrix} \mathbf{x}$$

where  $u(t) =$  unit step function.

**ANSWERS TO REVIEW QUESTIONS**

1. (1) Can model systems other than linear, constant coefficients; (2) Used for digital simulation
2. Yields qualitative insight
3. That smallest set of variables that completely describe the system
4. The value of the state variables
5. The vector whose components are the state variables
6. The n-dimensional space whose bases are the state variables
7. State equations, an output equation, and an initial state vector (initial conditions)
8. Eight
9. Forms linear combinations of the state variables and the input to form the desired output
10. No variable in the set can be written as a linear sum of the other variables in the set.
11. (1) They must be linearly independent; (2) The number of state variables must agree with the order of the differential equation describing the system; (3) The degree of difficulty in obtaining the state equations for a given set of state variables.
12. The variables that are being differentiated in each of the linearly independent energy storage elements

13. Yes, depending upon the choice of circuit variables and technique used to write the system equations. For example, a three-loop problem with three energy storage elements could yield three simultaneous second-order differential equations which would then be described by six, first-order differential equations. This exact situation arose when we wrote the differential equations for mechanical systems and then proceeded to find the state equations.
14. The state variables are successive derivatives.

## SOLUTIONS TO PROBLEMS

1. Add the branch currents and node voltages to the network.

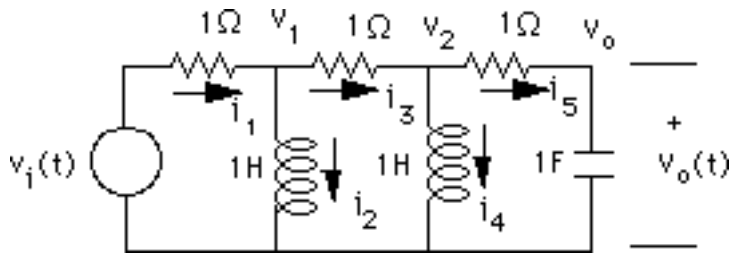

Write the differential equation for each energy storage element.

$$\begin{aligned}\frac{di_2}{dt} &= v_1 \\ \frac{di_4}{dt} &= v_2 \\ \frac{dv_o}{dt} &= i_5\end{aligned}$$

Therefore, the state vector is  $\mathbf{x} = \begin{bmatrix} i_2 \\ i_4 \\ v_o \end{bmatrix}$

Now obtain  $v_1$ ,  $v_2$ , and  $i_5$  in terms of the state variables. First find  $i_1$  in terms of the state variables.

$$-v_i + i_1 + i_3 + i_5 + v_o = 0$$

But  $i_3 = i_1 - i_2$  and  $i_5 = i_3 - i_4$ . Thus,

$$-v_i + i_1 + (i_1 - i_2) + (i_3 - i_4) + v_o = 0$$

Making the substitution for  $i_3$  yields

$$-v_i + i_1 + (i_1 - i_2) + ((i_1 - i_2) - i_4) + v_o = 0$$

Solving for  $i_1$

$$i_1 = \frac{2}{3}i_2 + \frac{1}{3}i_4 - \frac{1}{3}v_o + \frac{1}{3}v_i$$

Thus,

$$v_1 = v_i - i_1 = -\frac{2}{3}i_2 - \frac{1}{3}i_4 + \frac{1}{3}v_o + \frac{2}{3}v_i$$

Also,

$$i_3 = i_1 - i_2 = -\frac{1}{3}i_2 + \frac{1}{3}i_4 - \frac{1}{3}v_o + \frac{1}{3}v_i$$

and

$$i_5 = i_3 - i_4 = -\frac{1}{3}i_2 - \frac{2}{3}i_4 - \frac{1}{3}v_o + \frac{1}{3}v_i$$

Finally,

$$v_2 = i_5 + v_o = -\frac{1}{3}i_2 - \frac{2}{3}i_4 + \frac{2}{3}v_o + \frac{1}{3}v_i$$

Using  $v_1$ ,  $v_2$ , and  $i_5$ , the state equation is

$$\dot{\mathbf{x}} = \begin{bmatrix} -\frac{2}{3} & -\frac{1}{3} & \frac{1}{3} \\ \frac{1}{3} & -\frac{2}{3} & \frac{2}{3} \\ -\frac{1}{3} & -\frac{2}{3} & -\frac{1}{3} \end{bmatrix} \mathbf{x} + \begin{bmatrix} \frac{2}{3} \\ \frac{1}{3} \\ \frac{1}{3} \end{bmatrix} v_i$$

$$y = [0 \quad 0 \quad 1] \mathbf{x}$$

2.

Add branch currents and node voltages to the schematic and obtain,

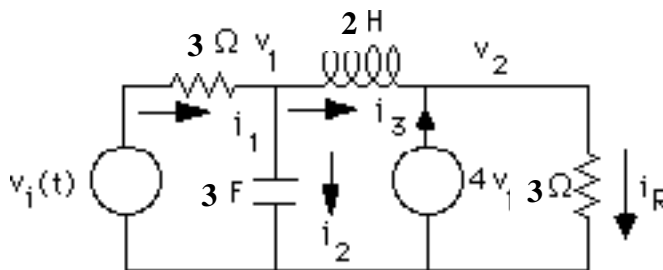

Write the differential equation for each energy storage element.

$$\frac{dv_1}{dt} = \frac{1}{3}i_2$$

$$\frac{di_3}{dt} = \frac{1}{2}v_L$$

Therefore the state vector is  $\mathbf{x} = \begin{bmatrix} v_1 \\ i_3 \end{bmatrix}$

Now obtain  $v_L$  and  $i_2$ , in terms of the state variables,

$$v_L = v_1 - v_2 = v_1 - 3i_R = v_1 - 3(i_3 + 4v_1) = -11v_1 - 3i_3$$

$$i_2 = i_1 - i_3 = \frac{1}{3}(v_i - v_1) - i_3 = -\frac{1}{3}v_1 - i_3 + \frac{1}{3}v_i$$

Also, the output is

$$y = i_R = 4v_1 + i_3$$

Hence,

$$\dot{\mathbf{x}} = \begin{bmatrix} -\frac{1}{9} & -\frac{1}{3} \\ -\frac{11}{2} & -\frac{3}{2} \end{bmatrix} \mathbf{x} + \begin{bmatrix} \frac{1}{9} \\ \mathbf{0} \end{bmatrix} v_i$$

$$y = [4 \quad 1] \mathbf{x}$$

3.

Let  $C_1$  be the grounded capacitor and  $C_2$  be the other. Now, writing the equations for the energy storage components yields,

$$\frac{di_L}{dt} = v_i - v_{C_1}$$

$$\frac{dv_{C_1}}{dt} = i_1 - i_2 \quad (1)$$

$$\frac{dv_{C_2}}{dt} = i_2 - i_3$$

Thus the state vector is  $\mathbf{x} = \begin{bmatrix} i_L \\ v_{C_1} \\ v_{C_2} \end{bmatrix}$ . Now, find the three loop currents in terms of the state variables

and the input.

Writing KVL around Loop 2 yields  $v_{C_1} = v_{C_2} + i_2$ . Or,

$$i_2 = v_{C_1} - v_{C_2}$$

Writing KVL around the outer loop yields  $i_3 + i_2 = v_i$  Or,

$$i_3 = v_i - i_2 = v_i - v_{C_1} + v_{C_2}$$

Also,  $i_1 - i_3 = i_L$ . Hence,

$$i_1 = i_L + i_3 = i_L + v_i - v_{C_1} + v_{C_2}$$

Substituting the loop currents in equations (1) yields the results in vector-matrix form,

$$\begin{bmatrix} \frac{di_L}{dt} \\ \frac{dv_{C_1}}{dt} \\ \frac{dv_{C_2}}{dt} \end{bmatrix} = \begin{bmatrix} 0 & -1 & 0 \\ 1 & -2 & 2 \\ 0 & 2 & -2 \end{bmatrix} \begin{bmatrix} i_L \\ v_{C_1} \\ v_{C_2} \end{bmatrix} + \begin{bmatrix} 1 \\ 1 \\ -1 \end{bmatrix} v_i$$

Since  $v_o = i_2 = v_{C_1} - v_{C_2}$ , the output equation is

$$y = \begin{bmatrix} 0 & 1 & -1 \end{bmatrix} \begin{bmatrix} i_L \\ v_{C_1} \\ v_{C_2} \end{bmatrix}$$

4.

Equations of motion in Laplace:

$$\begin{aligned} (2s^2 + 3s + 2)X_1(s) - (s + 2)X_2(s) - sX_3(s) &= 0 \\ -(s + 2)X_1(s) + (s^2 + 2s + 2)X_2(s) - sX_3(s) &= F(s) \\ -sX_1(s) - sX_2(s) + (s^2 + 3s)X_3(s) &= 0 \end{aligned}$$

Equations of motion in the time domain:

$$\begin{aligned} 2\frac{d^2x_1}{dt^2} + 3\frac{dx_1}{dt} + 2x_1 - \frac{dx_2}{dt} - 2x_2 - \frac{dx_3}{dt} &= 0 \\ -\frac{dx_1}{dt} - 2x_1 + \frac{d^2x_2}{dt^2} + 2\frac{dx_2}{dt} + 2x_2 - \frac{dx_3}{dt} &= f(t) \\ -\frac{dx_1}{dt} - \frac{dx_2}{dt} + \frac{d^2x_3}{dt^2} + 3\frac{dx_3}{dt} &= 0 \end{aligned}$$

Define state variables:

$$z_1 = x_1 \quad \text{or} \quad x_1 = z_1 \quad (1)$$

$$z_2 = \frac{dx_1}{dt} \quad \text{or} \quad \frac{dx_1}{dt} = z_2 \quad (2)$$

$$z_3 = x_2 \quad \text{or} \quad x_2 = z_3 \quad (3)$$

$$z_4 = \frac{dx_2}{dt} \quad \text{or} \quad \frac{dx_2}{dt} = z_4 \quad (4)$$

$$z_5 = x_3 \quad \text{or} \quad x_3 = z_5 \quad (5)$$

$$z_6 = \frac{dx_3}{dt} \quad \text{or} \quad \frac{dx_3}{dt} = z_6 \quad (6)$$

Substituting Eq. (1) in (2), (3) in (4), and (5) in (6), we obtain, respectively:

$$\frac{dz_1}{dt} = z_2 \quad (7)$$

$$\frac{dz_3}{dt} = z_4 \quad (8)$$

$$\frac{dz_5}{dt} = z_6 \quad (9)$$

Substituting Eqs. (1) through (6) into the equations of motion in the time domain and solving for the derivatives of the state variables and using Eqs. (7) through (9) yields the state equations:

$$\begin{aligned} \frac{dz_1}{dt} &= z_2 \\ \frac{dz_2}{dt} &= -z_1 - \frac{3}{2}z_2 + z_3 + \frac{1}{2}z_4 + \frac{1}{2}z_6 \\ \frac{dz_3}{dt} &= z_4 \\ \frac{dz_4}{dt} &= 2z_1 + z_2 - 2z_3 - 2z_4 + z_6 + f(t) \\ \frac{dz_5}{dt} &= z_6 \\ \frac{dz_6}{dt} &= z_2 + z_4 - 3z_6 \end{aligned}$$

The output is  $x_3 = z_5$ .

In vector-matrix form:

$$\dot{\mathbf{Z}} = \begin{bmatrix} 0 & 1 & 0 & 0 & 0 & 0 \\ -1 & -1.5 & 1 & 0.5 & 0 & 0.5 \\ 0 & 0 & 0 & 1 & 0 & 0 \\ 2 & 1 & -2 & -2 & 0 & 1 \\ 0 & 0 & 0 & 0 & 0 & 1 \\ 0 & 1 & 0 & 1 & 0 & -3 \end{bmatrix} \mathbf{Z} + \begin{bmatrix} 0 \\ 0 \\ 0 \\ 1 \\ 0 \\ 0 \end{bmatrix} f(t)$$

$$\mathbf{y} = [0 \ 0 \ 0 \ 0 \ 1 \ 0] \mathbf{Z}$$

5.

Writing the equations of motion,

$$\begin{aligned} (2s^2 + 2s + 1)X_1(s) - sX_2(s) - (s+1)X_3(s) &= 0 \\ -sX_1(s) + (s^2 + 2s + 1)X_2(s) - (s+1)X_3(s) &= 0 \\ -(s+1)X_1(s) - (s+1)X_2(s) + (s^2 + 2s + 2)X_3(s) &= F(s) \end{aligned}$$

Taking the inverse Laplace transform,

$$\begin{aligned} 2\ddot{x}_1 + 2\dot{x}_1 + x_1 - \dot{x}_2 - \dot{x}_3 - x_3 &= 0 \\ -\dot{x}_1 + \ddot{x}_2 + 2\dot{x}_2 + x_2 - \dot{x}_3 - x_3 &= 0 \\ -\dot{x}_1 - x_1 - \dot{x}_2 - x_2 + \ddot{x}_3 + 2\dot{x}_3 + 2x_3 &= f(t) \end{aligned}$$

Simplifying,

$$\begin{aligned} \ddot{x}_1 &= -\dot{x}_1 - \frac{1}{2}x_1 + \frac{1}{2}\dot{x}_2 + \frac{1}{2}\dot{x}_3 + \frac{1}{2}x_3 \\ \ddot{x}_2 &= \dot{x}_1 - 2\dot{x}_2 - x_2 + \dot{x}_3 + x_3 \\ \ddot{x}_3 &= \dot{x}_1 + x_1 + \dot{x}_2 + x_2 - 2\dot{x}_3 - 2x_3 + f(t) \end{aligned}$$

Defining the state variables,

$$z_1 = x_1; z_2 = \dot{x}_1; z_3 = x_2; z_4 = \dot{x}_2; z_5 = x_3; z_6 = \dot{x}_3$$

Writing the state equations using the simplified equations above yields,



$$\begin{aligned} \dot{z}_1 &= x_1 = z_2 \\ \dot{z}_2 &= x_1 = -z_2 - \frac{1}{2}z_1 + \frac{1}{2}z_4 + \frac{1}{2}z_6 + \frac{1}{2}z_5 \\ \dot{z}_3 &= x_2 = z_4 \\ \dot{z}_4 &= x_2 = z_2 - 2z_4 - z_3 + z_6 + z_5 \\ \dot{z}_5 &= x_3 = z_6 \\ \dot{z}_6 &= x_3 = z_2 + z_1 + z_4 + z_3 - 2z_6 - 2z_5 + f(t) \end{aligned}$$

Converting to vector-matrix form,

$$\dot{\mathbf{z}} = \begin{bmatrix} 0 & 1 & 0 & 0 & 0 & 0 \\ -\frac{1}{2} & -1 & 0 & \frac{1}{2} & \frac{1}{2} & \frac{1}{2} \\ 0 & 0 & 0 & 1 & 0 & 0 \\ 0 & 1 & -1 & -2 & 1 & 1 \\ 0 & 0 & 0 & 0 & 0 & 1 \\ 1 & 1 & 1 & 1 & -2 & -2 \end{bmatrix} \mathbf{z} + \begin{bmatrix} 0 \\ 0 \\ 0 \\ 0 \\ 0 \\ 1 \end{bmatrix} f(t)$$

$$y = [1 \ 0 \ 0 \ 0 \ 0 \ 0] \mathbf{z}$$

6.

Drawing the equivalent network,

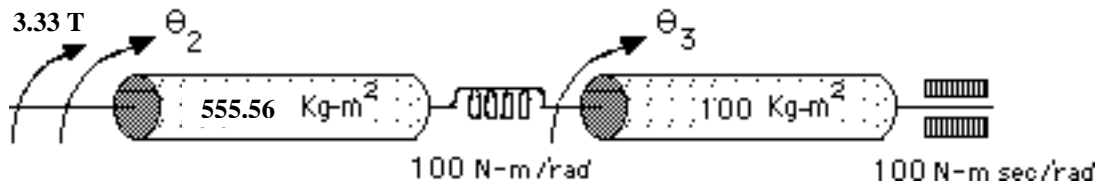

Writing the equations of motion,

$$\begin{aligned} (555.56s^2 + 100)\theta_2 - 100\theta_3 &= 3.33T \\ -100\theta_2 + (100s^2 + 100s + 100)\theta_3 &= 0 \end{aligned}$$

Taking the inverse Laplace transform and simplifying,

$$\ddot{\theta}_2 + 0.18\ddot{\theta}_2 - 0.18\ddot{\theta}_3 = 0.006T$$

$$-\ddot{\theta}_2 + \ddot{\theta}_3 + \dot{\theta}_3 + \theta_3 = 0$$

Defining the state variables as

$$x_1 = \theta_2, x_2 = \dot{\theta}_2, x_3 = \theta_3, x_4 = \dot{\theta}_3$$

Writing the state equations using the equations of motion and the definitions of the state variables

$$\begin{aligned} \dot{x}_1 &= x_2 \\ \dot{x}_2 &= \ddot{\theta}_2 = -0.18\ddot{\theta}_2 + 0.18\ddot{\theta}_3 + 0.006T = -0.18x_1 + 0.18x_3 + 0.006T \\ \dot{x}_3 &= x_4 \\ \dot{x}_4 &= \ddot{\theta}_3 = \ddot{\theta}_2 - \ddot{\theta}_3 - \dot{\theta}_3 = x_1 - x_3 - x_4 \\ y &= 3.33\theta_2 = 3.33x_1 \end{aligned}$$

In vector-matrix form,

$$\dot{\mathbf{x}} = \begin{bmatrix} 0 & 1 & 0 & 0 \\ -0.18 & 0 & 0.18 & 0 \\ 0 & 0 & 0 & 1 \\ 1 & 0 & -1 & -1 \end{bmatrix} \mathbf{x} + \begin{bmatrix} 0 \\ 0.006 \\ 0 \\ 0 \end{bmatrix} T$$

$$y = [3.33 \ 0 \ 0 \ 0] \mathbf{x}$$

7.

Drawing the equivalent circuit,

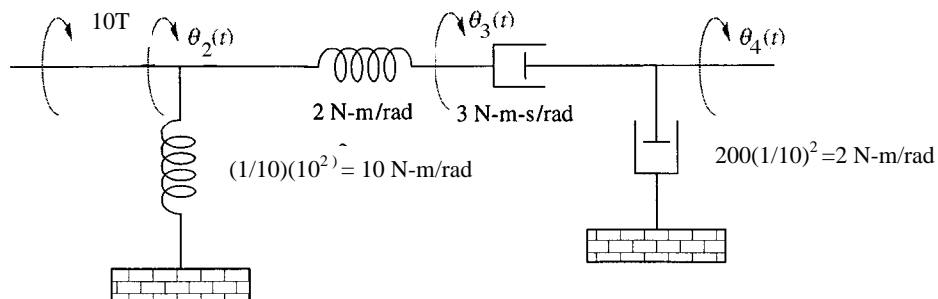

Writing the equations of motion,

$$\begin{aligned}
12\theta_2(s) - 2\theta_3(s) &= 10T(s) \\
-2\theta_2(s) + (3s + 2)\theta_3(s) - 3s\theta_4(s) &= 0 \\
-3s\theta_3(s) + 5s\theta_4(s) &= 0
\end{aligned}$$

Taking the inverse Laplace transform,

$$12\theta_2(t) - 2\theta_3(t) = 10T(t) \quad (1)$$

$$-2\theta_2(t) + 3\dot{\theta}_3(t) + 2\theta_3 - 3\dot{\theta}_4(t) = 0 \quad (2)$$

$$-3\dot{\theta}_3(t) + 5\dot{\theta}_4(t) = 0 \quad (3)$$

From (3),

$$\dot{\theta}_3(t) = \frac{5}{3}\dot{\theta}_4(t) \text{ and } \theta_3(t) = \frac{5}{3}\theta_4(t) \quad (4)$$

assuming zero initial conditions.

From (1)

$$\theta_2(t) = \frac{1}{6}\theta_3(t) + \frac{5}{6}T(t) = \frac{5}{18}\theta_4(t) + \frac{5}{6}T(t) \quad (5)$$

Substituting (4) and (5) into (2) yields the state equation (notice there is only one equation),

$$\dot{\theta}_4(t) = -\frac{25}{18}\theta_4(t) + \frac{5}{6}T(t)$$

The output equation is given by,

$$\theta_L(t) = \frac{1}{10}\theta_4(t)$$

8.

Solving Eqs. (3.44) and (3.45) in the text for the transfer functions  $\frac{X_1(s)}{F(s)}$  and  $\frac{X_2(s)}{F(s)}$ :

$$X_1(s) = \frac{\begin{vmatrix} 0 & -K \\ F & M_2 s^2 + K \end{vmatrix}}{\begin{vmatrix} M_1 s^2 + D s + K & -K \\ -K & M_2 s^2 + K \end{vmatrix}} \text{ and } X_2(s) = \frac{\begin{vmatrix} M_1 s^2 + D s + K & 0 \\ -K & F \end{vmatrix}}{\begin{vmatrix} M_1 s^2 + D s + K & -K \\ -K & M_2 s^2 + K \end{vmatrix}}$$

Thus,

$$\frac{X_1(s)}{F(s)} = \frac{K}{M_2 M_1 s^4 + D M_2 s^3 + K M_2 s^2 + K M_1 s^2 + D K s}$$

and

$$\frac{X_2(s)}{F(s)} = \frac{M_1 s^2 + D s + K}{M_2 M_1 s^4 + D M_2 s^3 + K M_2 s^2 + K M_1 s^2 + D K s}$$

Multiplying each of the above transfer functions by  $s$  to find velocity yields pole/zero cancellation at the origin and a resulting transfer function that is third order.

9.

a. . Using the standard form derived in the textbook,

$$\dot{\mathbf{x}} = \begin{bmatrix} 0 & 1 & 0 & 0 \\ 0 & 0 & 1 & 0 \\ 0 & 0 & 0 & 1 \\ -100 & -7 & -10 & -20 \end{bmatrix} \mathbf{x} + \begin{bmatrix} 0 \\ 0 \\ 0 \\ 1 \end{bmatrix} r(t)$$

$$c = [100 \ 0 \ 0 \ 0] \mathbf{x}$$

b. Using the standard form derived in the textbook,

$$\dot{\mathbf{x}} = \begin{bmatrix} 0 & 1 & 0 & 0 & 0 \\ 0 & 0 & 1 & 0 & 0 \\ 0 & 0 & 0 & 1 & 0 \\ 0 & 0 & 0 & 0 & 1 \\ -30 & -1 & -6 & -9 & -8 \end{bmatrix} \mathbf{x} + \begin{bmatrix} 0 \\ 0 \\ 0 \\ 0 \\ 1 \end{bmatrix} r(t)$$

$$c = [30 \ 0 \ 0 \ 0 \ 0] \mathbf{x}$$

10.

**Program:**

```
'a'
num=100;
den=[1 20 10 7 100];
G=tf(num,den)
[Acc,Bcc,Ccc,Dcc]=tf2ss(num,den);
Af=flipud(Acc);
A=fliplr(Af)
B=flipud(Bcc)
C=fliplr(Ccc)
'b'
num=30;
den=[1 8 9 6 1 30];
G=tf(num,den)
[Acc,Bcc,Ccc,Dcc]=tf2ss(num,den);
Af=flipud(Acc);
A=fliplr(Af)
B=flipud(Bcc)
C=fliplr(Ccc)
```

**Computer response:**

ans =

a

Transfer function:

100

-----  
s^4 + 20 s^3 + 10 s^2 + 7 s + 100

A =

```
0 1 0 0
0 0 1 0
0 0 0 1
-100 -7 -10 -20
```

B =

0  
0  
0  
1

C =

100    0    0    0

ans =

b

Transfer function:

30

-----  
s^5 + 8 s^4 + 9 s^3 + 6 s^2 + s + 30

A =

0    1    0    0    0  
0    0    1    0    0  
0    0    0    1    0  
0    0    0    0    1  
-30   -1   -6   -9   -8

B =

0  
0  
0  
0  
1

C =

30    0    0    0    0

11.

a. Using the standard form derived in the textbook,

$$\dot{\mathbf{x}} = \begin{bmatrix} 0 & 1 & 0 & 0 \\ 0 & 0 & 1 & 0 \\ 0 & 0 & 0 & 1 \\ -13 & -5 & -1 & -5 \end{bmatrix} \mathbf{x} + \begin{bmatrix} 0 \\ 0 \\ 0 \\ 1 \end{bmatrix} r(t)$$

$$c = [10 \ 8 \ 0 \ 0 \ 0] \mathbf{x}$$

b. Using the standard form derived in the textbook,

$$\dot{\mathbf{x}} = \begin{bmatrix} 0 & 1 & 0 & 0 & 0 \\ 0 & 0 & 1 & 0 & 0 \\ 0 & 0 & 0 & 1 & 0 \\ 0 & 0 & 0 & 0 & 1 \\ 0 & 0 & -8 & -13 & -9 \end{bmatrix} \mathbf{x} + \begin{bmatrix} 0 \\ 0 \\ 0 \\ 0 \\ 1 \end{bmatrix} r(t)$$

$$c = [6 \ 7 \ 12 \ 2 \ 1] \mathbf{x}$$

12.

**Program:**

```
'a'
num=[8 10];
den=[1 5 1 5 13]
G=tf(num,den)
[Acc,Bcc,Ccc,Dcc]=tf2ss(num,den);
Af=flipud(Acc);
A=fliplr(Af)
B=flipud(Bcc)
C=fliplr(Ccc)
'b'
num=[1 2 12 7 6];
den=[1 9 13 8 0 0]
G=tf(num,den)
[Acc,Bcc,Ccc,Dcc]=tf2ss(num,den);
Af=flipud(Acc);
A=fliplr(Af)
B=flipud(Bcc)
C=fliplr(Ccc)
```

**Computer response:**

ans =

ans =

a

den =

1 5 1 5 13

Transfer function:

8 s + 10

-----  
s^4 + 5 s^3 + s^2 + 5 s + 13

A =

0 1 0 0  
0 0 1 0  
0 0 0 1  
-13 -5 -1 -5

```

B =
    0
    0
    0
    1

C =
    10    8    0    0

ans =

b

den =
    1    9    13    8    0    0
    
```

Transfer function:  

$$\frac{s^4 + 2s^3 + 12s^2 + 7s + 6}{s^5 + 9s^4 + 13s^3 + 8s^2}$$

```

A =
    0    1    0    0    0
    0    0    1    0    0
    0    0    0    1    0
    0    0    0    0    1
-----
    1          0    0   -8   -13   -9
s^3 + 6s^2 + 10s + 5
    
```

```

B =
    0
    0
    0
    0
    1

C =
    6    7    12    2    1
    
```

13.

The transfer function can be represented as a block diagram as follows:

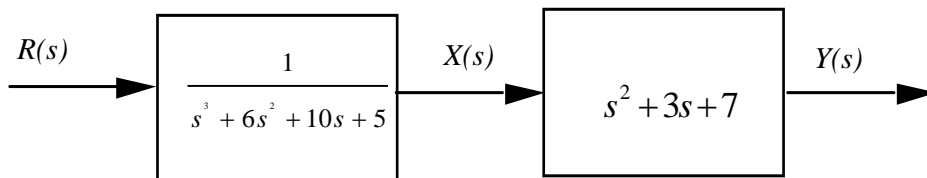

Writing the differential equation for the first box:

$$\overset{\bullet\bullet\bullet}{x} + 6\overset{\bullet\bullet}{x} + 10\overset{\bullet}{x} + 5x = r(t)$$

Defining the state variables:

$$x_1 = x$$

$$x_2 = \overset{\bullet}{x}$$

$$x_3 = \overset{\bullet\bullet}{x}$$

Thus,

$$\overset{\bullet}{x}_1 = x_2$$

$$\overset{\bullet}{x}_2 = x_3$$

$$\overset{\bullet}{x}_3 = -5x - 10\overset{\bullet}{x} - 6\overset{\bullet\bullet}{x} + r(t) = -5x_1 - 10x_2 - 6x_3 + r(t)$$

From the second box,

$$y = \overset{\bullet\bullet}{x} + 3\overset{\bullet}{x} + 8x = 8x_1 + 3x_2 + x_3$$

In vector-matrix form:

$$\overset{\bullet}{\mathbf{x}} = \begin{bmatrix} 0 & 1 & 0 \\ 0 & 0 & 1 \\ -5 & -10 & -6 \end{bmatrix} \mathbf{x} + \begin{bmatrix} 0 \\ 0 \\ 1 \end{bmatrix} r(t)$$

$$y = [8 \quad 3 \quad 1] \mathbf{x}$$

14.

a.  $G(s) = \mathbf{C}(s\mathbf{I} - \mathbf{A})^{-1}\mathbf{B}$

$$\mathbf{A} = \begin{bmatrix} 0 & 1 & 0 \\ 0 & 0 & 1 \\ -3 & -2 & -5 \end{bmatrix}; \mathbf{B} = \begin{bmatrix} 0 \\ 0 \\ 10 \end{bmatrix}; \mathbf{C} = [1 \quad 0 \quad 0]$$

$$(s\mathbf{I} - \mathbf{A})^{-1} = \frac{1}{s^3 + 5s^2 + 2s + 3} \begin{bmatrix} s^2 + 5s + 2 & s + 5 & 1 \\ -3 & s(s + 5) & s \\ -3s & -2s - 3 & s^2 \end{bmatrix}$$

$$\text{Therefore, } G(s) = \frac{10}{s^3 + 5s^2 + 2s + 3}.$$

b.  $G(s) = \mathbf{C}(s\mathbf{I} - \mathbf{A})^{-1}\mathbf{B}$

$$\mathbf{A} = \begin{bmatrix} 2 & 3 & -8 \\ 0 & 5 & 3 \\ -3 & -5 & -4 \end{bmatrix}; \mathbf{B} = \begin{bmatrix} 1 \\ 4 \\ 6 \end{bmatrix}; \mathbf{C} = (1, 3, 6)$$



$$(s\mathbf{I}-\mathbf{A})^{-1} = \frac{1}{s^3 - 3s^2 - 27s + 157} \begin{pmatrix} s^2 - s - 5 & 3s + 52 & -8s + 49 \\ -9 & s^2 + 2s - 32 & 3s - 6 \\ -3s + 15 & -5s + 1 & s^2 - 7s + 10 \end{pmatrix}$$

$$\text{Therefore, } G(s) = \frac{49s^2 - 349s + 452}{s^3 - 3s^2 - 27s + 157}.$$

$$\text{c. } G(s) = \mathbf{C}(s\mathbf{I}-\mathbf{A})^{-1}\mathbf{B}$$

$$\mathbf{A} = \begin{bmatrix} 3 & -5 & 2 \\ 1 & -8 & 7 \\ -3 & -6 & 2 \end{bmatrix}; \quad \mathbf{B} = \begin{bmatrix} 5 \\ -3 \\ 2 \end{bmatrix}; \quad \mathbf{C} = [1 \quad -4 \quad 3]$$

$$(s\mathbf{I}-\mathbf{A})^{-1} = \frac{1}{s^3 + 3s^2 + 19s - 133} \begin{bmatrix} (s^2 + 6s + 26) & -(5s + 2) & (2s - 19) \\ (s - 23) & (s^2 - 5s + 12) & (7s - 19) \\ -(3s + 30) & -(6s - 33) & (s^2 + 5s - 19) \end{bmatrix}$$

$$\text{Therefore, } G(s) = \frac{23s^2 - 48s - 7}{s^3 + 3s^2 + 19s - 133}.$$

15.

**Program:**

```
'a'
A=[0 1 5 0;0 0 1 0;0 0 0 1;-7 -9 -2 -3];
B=[0;5;8;2];
C=[1 3 6 6];
D=0;
statespace=ss(A,B,C,D)
[num,den]=ss2tf(A,B,C,D);
G=tf(num,den)
'b'
A=[3 1 0 4 -2;-3 5 -5 2 -1;0 1 -1 2 8;-7 6 -3 -4 0;-6 0 4 -3 1];
B=[2;7;8;5;4];
C=[1 -2 -9 7 6];
D=0;
statespace=ss(A,B,C,D)
[num,den]=ss2tf(A,B,C,D);
G=tf(num,den)
```

**Computer response:**

ans =

a

a =

	x1	x2	x3	x4
x1	0	1	5	0
x2	0	0	1	0
x3	0	0	0	1
x4	-7	-9	-2	-3

3-18 Chapter 3: Modeling in the Time Domain

```
b =
      u1
x1    0
x2    5
x3    8
x4    2
```

```
c =
      x1  x2  x3  x4
y1    1   3   6   6
```

```
d =
      u1
y1    0
```

Continuous-time model.

```
Transfer function:
75 s^3 - 96 s^2 - 2331 s - 210
-----
s^4 + 3 s^3 + 2 s^2 + 44 s + 7
```

```
ans =
```

```
b
```

```
a =
      x1  x2  x3  x4  x5
x1    3   1   0   4  -2
x2   -3   5  -5   2  -1
x3    0   1  -1   2   8
x4   -7   6  -3  -4   0
x5   -6   0   4  -3   1
```

```
b =
      u1
x1    2
x2    7
x3    8
x4    5
x5    4
```

```
c =
      x1  x2  x3  x4  x5
y1    1  -2  -9   7   6
```

```
d =
      u1
y1    0
```

Continuous-time model.

```
Transfer function:
-25 s^4 - 292 s^3 + 1680 s^2 + 1.628e004 s + 3.188e004
-----
s^5 - 4 s^4 - 32 s^3 + 148 s^2 - 1153 s - 4480
```

**16.**

**Program:**

```
syms s
'a'
A=[0 1 3 0
0 0 1 0
```

```

0 0 0 1
-7 -9 -2 -3];
B=[0;5;8;2];
C=[1 3 4 6];
D=0;
I=[1 0 0 0
0 1 0 0
0 0 1 0
0 0 0 1];
'T(s)'
T=C*((s*I-A)^-1)*B+D;
T=simple(T);
pretty(T)
'b'
A=[3 1 0 4 -2
-3 5 -5 2 -1
0 1 -1 2 8
-7 6 -3 -4 0
-6 0 4 -3 1];
B=[2;7;6;5;4];
C=[1 -2 -9 7 6];
D=0;
I=[1 0 0 0 0
0 1 0 0 0
0 0 1 0 0
0 0 0 1 0
0 0 0 0 1];
'T(s)'
T=C*((s*I-A)^-1)*B+D;
T=simple(T);
pretty(T)

```

**Computer response:**

ans =

a

ans =

T(s)

$$\frac{-164 s^2 - 1621 s - 260 + 59 s^3}{s^4 + 3 s^3 + 2 s^2 + 30 s + 7}$$

ans =

b

ans =

T(s)

$$\frac{14582 s^2 + 1708 s^3 - 408 s^4 - 7 s^5 + 27665}{s^5 - 4 s^4 - 32 s^3 + 148 s^2 - 1153 s - 4480}$$

**17.**

Let the input be  $\frac{d\theta_z}{dt} = \omega_z$ ,  $x_1 = \theta_x$ ,  $x_2 = \dot{\theta}_x$ . Therefore,

$$\dot{x}_1 = x_2$$

$$\dot{x}_2 = -\frac{K_x}{J_x} x_1 - \frac{D_x}{J_x} x_2 + J\omega\omega_z$$

The output is  $\theta_x$ .

In vector-matrix form,  $\theta_x = x_1$ . Therefore,  $y = x_1$ .

$$\dot{\mathbf{x}} = \begin{bmatrix} 0 & 1 \\ -\frac{K_x}{J_x} & -\frac{D_x}{J_x} \end{bmatrix} \mathbf{x} + \begin{bmatrix} 0 \\ J\omega \end{bmatrix} \omega_z$$

$$y = \begin{bmatrix} 1 & 0 \end{bmatrix} \mathbf{x}$$

18.

The equivalent cascade transfer function is as shown below.

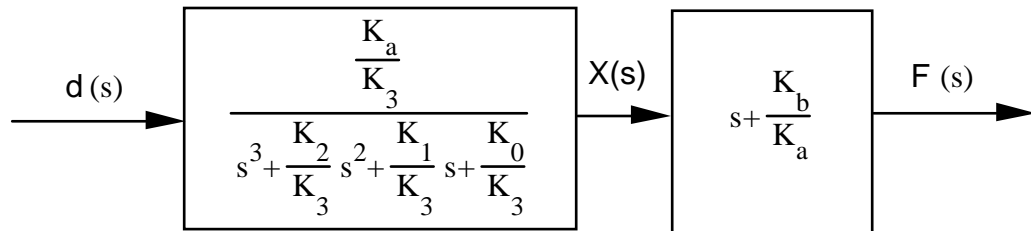

For the first box,  $\ddot{\ddot{x}} + \frac{K_2}{K_3} \ddot{x} + \frac{K_1}{K_3} \dot{x} + \frac{K_0}{K_3} x = \frac{K_a}{K_3} \delta(t)$ .

Selecting the phase variables as the state variables:  $x_1 = x$ ,  $x_2 = \dot{x}$ ,  $x_3 = \ddot{x}$ .

Writing the state and output equations:

$$\begin{aligned} \dot{x}_1 &= x_2 \\ \dot{x}_2 &= x_3 \\ \dot{x}_3 &= -\frac{K_0}{K_3} x_1 - \frac{K_1}{K_3} x_2 - \frac{K_2}{K_3} x_3 + \frac{K_a}{K_3} \delta(t) \\ y &= \phi(t) = x = \frac{K_b}{K_a} x_1 \end{aligned}$$

In vector-matrix form,

$$\dot{\mathbf{x}} = \begin{bmatrix} 0 & 1 & 0 \\ 0 & 0 & 1 \\ -\frac{K_0}{K_3} & -\frac{K_1}{K_3} & -\frac{K_2}{K_3} \end{bmatrix} \mathbf{x} + \begin{bmatrix} 0 \\ 0 \\ \frac{K_a}{K_3} \end{bmatrix} \delta(t); y = \begin{bmatrix} \frac{K_b}{K_a} & 1 & 0 \end{bmatrix} \mathbf{x}$$

19.

Since  $T_m = J_{eq} \frac{d\omega_m}{dt} + D_{eq}\omega_m$ , and  $T_m = K_t i_a$ ,

$$J_{eq} \frac{d\omega_m}{dt} + D_{eq}\omega_m = K_t i_a \quad (1)$$

Or,

$$\frac{d\omega_m}{dt} = -\frac{D_{eq}}{J_{eq}} \omega_m + \frac{K_t}{J_{eq}} i_a$$

But,  $\omega_m = \frac{N_2}{N_1} \omega_L$ .

Substituting in (1) and simplifying yields the first state equation,

$$\frac{d\omega_L}{dt} = -\frac{D_{eq}}{J_{eq}} \omega_L + \frac{K_t}{J_{eq}} \frac{N_1}{N_2} i_a$$

The second state equation is:

$$\frac{d\theta_L}{dt} = \omega_L$$

Since

$$e_a = R_a i_a + L_a \frac{di_a}{dt} + K_b \omega_m = R_a i_a + L_a \frac{di_a}{dt} + K_b \frac{N_2}{N_1} \omega_L,$$

the third state equation is found by solving for  $\frac{di_a}{dt}$ . Hence,

$$\frac{di_a}{dt} = -\frac{K_b N_2}{L_a N_1} \omega_L - \frac{R_a}{L_a} i_a + \frac{1}{L_a} e_a$$

Thus the state variables are:  $x_1 = \omega_L$ ,  $x_2 = \theta_L$ , and  $x_3 = i_a$ .

Finally, the output is  $y = \theta_m = \frac{N_2}{N_1} \theta_L$ .

In vector-matrix form,

$$\dot{\mathbf{x}} = \begin{bmatrix} -\frac{D_{eq}}{J_{eq}} & 0 & \frac{K_t}{J_{eq}} \frac{N_1}{N_2} \\ 1 & 0 & 0 \\ -\frac{K_b}{L_a} \frac{N_2}{N_1} & 0 & -\frac{R_a}{L_a} \end{bmatrix} \mathbf{x} + \begin{bmatrix} 0 \\ 0 \\ \frac{1}{L_a} \end{bmatrix} e_a ; y = \begin{bmatrix} 0 & \frac{N_2}{N_1} & 0 \end{bmatrix} \mathbf{x}$$

where,

$$\mathbf{x} = \begin{bmatrix} \omega_L \\ \theta_L \\ i_a \end{bmatrix}$$

20.

Writing the differential equations,

$$\frac{d^2x_1}{dt^2} + \frac{dx_1}{dt} + 2x_1^2 - \frac{dx_2}{dt} = 0$$

$$\frac{d^2x_2}{dt^2} + \frac{dx_2}{dt} - \frac{dx_1}{dt} = f(t)$$

Defining the state variables to be  $x_1, v_1, x_2, v_2$ , where v's are velocity,

$$\dot{x}_1 = v_1$$

$$\dot{x}_2 = v_2$$

$$\dot{v}_1 = -v_1 - 2x_1^2 + v_2$$

$$\dot{v}_2 = v_1 - v_2 + f(t)$$

Around  $x_1 = 1$ ,  $x_1 = 1 + \delta x_1$ , and  $\dot{x}_1 = \delta \dot{x}_1$ . Also,

$$x_1^2 = x_1^2 \Big|_{x=1} + \frac{dx_1}{dt} \Big|_{x=1} \delta x_1 = 1 + 2x_1 \Big|_{x=1} \delta x_1 = 1 + 2\delta x_1$$

Therefore, the state and output equations are,

$$\delta \dot{x}_1 = v_1$$

$$\dot{x}_2 = v_2$$

$$\dot{v}_1 = -v_1 - 2(1 + 2\delta x_1) + v_2$$

$$\dot{v}_2 = v_1 - v_2 + f(t)$$

$$y = x_2$$

In vector-matrix form,

$$\begin{bmatrix} \dot{\delta x}_1 \\ \dot{x}_2 \\ \dot{v}_1 \\ \dot{v}_2 \end{bmatrix} = \begin{bmatrix} 0 & 0 & 1 & 0 \\ 0 & 0 & 0 & 1 \\ -4 & 0 & -1 & 1 \\ 0 & 0 & 1 & -1 \end{bmatrix} \begin{bmatrix} \delta x_1 \\ x_2 \\ v_1 \\ v_2 \end{bmatrix} + \begin{bmatrix} 0 & 0 \\ 0 & 0 \\ -2 & 0 \\ 0 & 1 \end{bmatrix} \begin{bmatrix} 1 \\ f(t) \end{bmatrix}; y = \begin{bmatrix} 0 & 1 & 0 & 0 \end{bmatrix} \begin{bmatrix} \delta x_1 \\ x_2 \\ v_1 \\ v_2 \end{bmatrix}$$

where  $f(t) = 2 + \delta f(t)$ , since force in nonlinear spring is 2 N and must be balanced by 2 N force on damper.

21.

Controller:

The transfer function can be represented as a block diagram as follows:

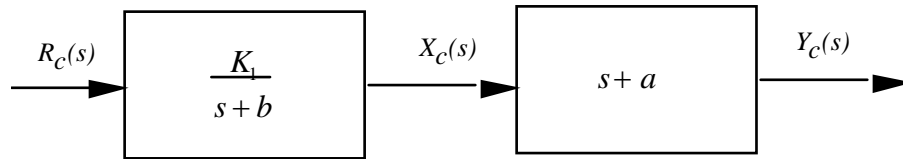

Writing the differential equation for the first box,

$$\frac{K_1}{s + b}$$

and solving for  $\dot{x}_c$ ,

$$\dot{x}_c = -bx_c + K_1 r_c(t)$$

From the second box,

$$\begin{aligned} y_c &= \dot{x}_c + ax_c = -bx_c + K_1 r_c(t) + ax_c \\ &= (a - b)x_c + K_1 r_c(t) \end{aligned}$$

Wheels:

The transfer function can be represented as a block diagram as follows:

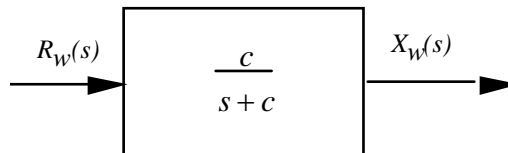

Writing the differential equation for the block of the form,

$$\frac{c}{s + c}$$

and solving for  $\dot{x}_w$ ,

$$\dot{x}_w = -cx_w + cr_w(t)$$

The output equation is,

$$y_w = x_w$$

Vehicle:

The transfer function can be represented as a block diagram as follows:

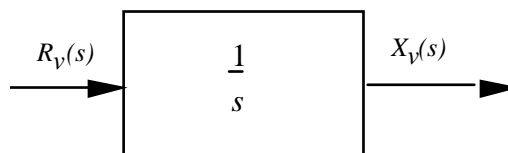

Writing the differential equation for the block,

$$\frac{1}{s}$$

and solving for  $\dot{x}_v$ ,

$$\dot{x}_v = r_v(t)$$

The output equation is

$$y_v = x_v$$

22.

$$\mathbf{A} = \begin{pmatrix} -1.702 & 50.72 & 263.38 \\ 0.22 & -1.418 & -31.99 \\ 0 & 0 & -14 \end{pmatrix}; \mathbf{B} = \begin{pmatrix} -272.06 \\ 0 \\ 14 \end{pmatrix}$$

For  $G_1(s)$ ,  $\mathbf{C}_1 = (1, 0, 0)$ , and

$$G_1(s) = \mathbf{C}_1(\mathbf{sI} - \mathbf{A})^{-1}\mathbf{B}$$

Thus,

$$G_1(s) = \mathbf{C}_1 \left( \frac{1}{s^3 + 17.12s^2 + 34.935s - 122.43} \begin{bmatrix} s^2 + 15.418s + 19.852 & 50.72s + 710.08 & 263.38s - 1249.1 \\ 0.22s + 3.08 & s^2 + 15.702s + 23.828 & -31.99s + 3.4966 \\ 0 & 0 & s^2 + 3.12s - 8.745 \end{bmatrix} \right) \mathbf{B}$$

Or

$$G_1(s) = \frac{-272.06s^2 - 507.3s - 22888}{s^3 + 17.12s^2 + 34.935s - 122.43} = \frac{-272.06(s^2 + 1.8647s + 84.128)}{(s + 14)(s - 1.7834)(s + 4.9034)}$$

For  $G_2(s)$ ,  $\mathbf{C}_2 = (0, 1, 0)$ , and

$$G_2(s) = \mathbf{C}_2(\mathbf{sI} - \mathbf{A})^{-1}\mathbf{B}$$

Thus,

$$G_2(s) = \mathbf{C}_2 \left( \frac{1}{s^3 + 17.12s^2 + 34.935s - 122.43} \begin{bmatrix} s^2 + 15.418s + 19.852 & 50.72s + 710.08 & 263.38s - 1249.1 \\ 0.22s + 3.08 & s^2 + 15.702s + 23.828 & -31.99s + 3.4966 \\ 0 & 0 & s^2 + 3.12s - 8.745 \end{bmatrix} \right) \mathbf{B}$$

Or

$$G_2(s) = \frac{-507.71s - 788.99}{s^3 + 17.12s^2 + 34.935s - 122.43} = \frac{-507.71(s + 1.554)}{(s + 14)(s - 1.7834)(s + 4.9034)}$$



23. Adding displacements to the figure,

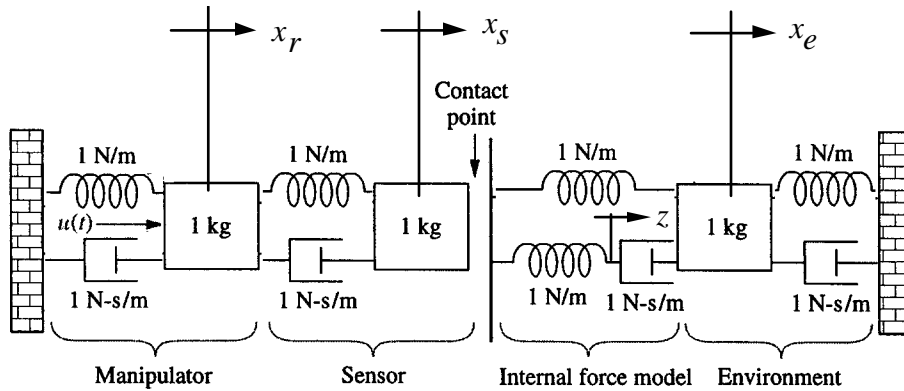

Writing the differential equations for noncontact,

$$\begin{aligned} \frac{d^2 x_r}{dt^2} + 2 \frac{dx_r}{dt} + 2x_r - x_s - \frac{dx_s}{dt} &= u(t) \\ -\frac{dx_r}{dt} - x_r + \frac{d^2 x_s}{dt^2} + \frac{dx_s}{dt} + x_s &= 0 \end{aligned}$$

Define the state variables as,

$$x_1 = x_r; x_2 = \dot{x}_r; x_3 = x_s; x_4 = \dot{x}_s$$

Writing the state equations, using the differential equations and the definition of the state variables,

we get,

$$\begin{aligned} \dot{x}_1 &= x_2 \\ \dot{x}_2 &= \ddot{x}_r = -2x_1 - 2x_2 + x_3 + x_4 + u(t) \\ \dot{x}_3 &= \dot{x}_s = x_4 \\ \dot{x}_4 &= \ddot{x}_s = x_1 + x_2 - x_3 - x_4 \end{aligned}$$

Assuming the output to be  $x_s$ , the output equation is,

$$y = x_3$$

In vector-matrix form,

$$\dot{\mathbf{x}} = \begin{bmatrix} 0 & 1 & 0 & 0 \\ -2 & -2 & 1 & 1 \\ 0 & 0 & 0 & 1 \\ 1 & 1 & -1 & -1 \end{bmatrix} \mathbf{x} + \begin{bmatrix} 0 \\ 1 \\ 0 \\ 0 \end{bmatrix} u(t)$$

$$y = [0 \ 0 \ 1 \ 0] \mathbf{x}$$

Writing the differential equations for contact,

$$\begin{aligned} \frac{d^2 x_r}{dt^2} + 2 \frac{dx_r}{dt} + 2x_r - x_s - \frac{dx_s}{dt} &= u(t) \\ -\frac{dx_r}{dt} - x_r + \frac{d^2 x_s}{dt^2} + \frac{dx_s}{dt} + x_s - z - x_e &= 0 \\ -x_s + \frac{dz}{dt} + z - \frac{dx_e}{dt} &= 0 \\ -x_s - \frac{dz}{dt} + \frac{d^2 x_e}{dt^2} + 2 \frac{dx_e}{dt} + 2x_e &= 0 \end{aligned}$$

Defining the state variables,

$$x_1 = x_r; x_2 = \dot{x}_r; x_3 = x_s; x_4 = \dot{x}_s; x_5 = z; x_6 = \dot{z}; x_7 = x_e; x_8 = \dot{x}_e$$

Using the differential equations and the definitions of the state variables, we write the state equations.

$$\begin{aligned} \dot{x}_1 &= x_2 \\ \dot{x}_2 &= -x_1 - 2x_2 + x_3 + x_4 + u(t) \\ \dot{x}_3 &= x_4 \\ \dot{x}_4 &= x_1 + x_2 - x_3 - x_4 + x_5 + x_7 \\ \dot{x}_5 &= x_6 \\ \dot{x}_6 &= x_8 \end{aligned}$$

Differentiating the third differential equation and solving for  $d^2z/dt^2$  we obtain,

$$\dot{x}_6 = \frac{d^2 z}{dt^2} = \frac{dx_s}{dt} - \frac{dz}{dt} + \frac{d^2 x_e}{dt^2}$$

But, from the fourth differential equation,

$$\frac{d^2 x_e}{dt^2} = x_s + \frac{dz}{dt} - 2 \frac{dx_e}{dt} - 2x_e = x_3 + x_6 - 2x_8 - 2x_7$$

Substituting this expression back into  $\dot{x}_6$  along with the other definitions and then simplifying yields,

$$\dot{x}_6 = x_4 + x_3 - 2x_8 - 2x_7$$

Continuing,

$$\begin{aligned}\dot{x}_7 &= x_8 \\ \dot{x}_8 &= x_3 + x_6 - 2x_7 - 2x_8\end{aligned}$$

Assuming the output is  $x_5$ ,

$$y = x_5$$

Hence, the solution in vector-matrix form is

$$\begin{aligned}\dot{\mathbf{x}} &= \begin{bmatrix} 0 & 1 & 0 & 0 & 0 & 0 & 0 & 0 \\ -1 & -2 & 1 & 1 & 0 & 0 & 0 & 0 \\ 0 & 0 & 0 & 1 & 0 & 0 & 0 & 0 \\ 1 & 1 & -1 & -1 & 1 & 0 & 1 & 0 \\ 0 & 0 & 0 & 0 & 0 & 1 & 0 & 0 \\ 0 & 0 & 1 & 1 & 0 & 0 & -2 & -2 \\ 0 & 0 & 0 & 0 & 0 & 0 & 0 & 1 \\ 0 & 0 & 1 & 0 & 0 & 1 & -2 & -2 \end{bmatrix} \mathbf{x} + \begin{bmatrix} 0 \\ 1 \\ 0 \\ 0 \\ 0 \\ 0 \\ 0 \\ 0 \end{bmatrix} u(t) \\ y &= [0 \ 0 \ 1 \ 0 \ 0 \ 0 \ 0 \ 0] \mathbf{x}\end{aligned}$$

24.

a. We begin by calculating

$$\mathbf{sI} - \mathbf{A} = \begin{pmatrix} s + 0.435 & -0.209 & -0.02 \\ -0.268 & s + 0.394 & 0 \\ -0.227 & 0 & s + 0.02 \end{pmatrix}$$

and

$$\begin{aligned}\det(\mathbf{sI} - \mathbf{A}) &= (s + 0.435) \begin{vmatrix} s + 0.394 & 0 \\ 0 & s + 0.02 \end{vmatrix} + 0.209 \begin{vmatrix} -0.268 & 0 \\ -0.227 & s + 0.02 \end{vmatrix} - 0.02 \begin{vmatrix} -0.268 & s + 0.394 \\ -0.227 & 0 \end{vmatrix} \\ &= (s + 0.435)(s + 0.394)(s + 0.02) + 0.209(-0.268)(s + 0.02) - 0.02(0.227)(s + 0.394) \\ &= s^3 + 0.849s^2 + 0.188s + 0.0034 - 0.056s - 0.00112 - 0.00454s - 0.00179 \\ &= s^3 + 0.849s^2 + 0.1278s + 0.00049 = (s + 0.66)(s + 0.19)(s + 0.004)\end{aligned}$$

$$\text{Adj}(\mathbf{sI} - \mathbf{A}) = \begin{pmatrix} c_{11} & c_{21} & c_{31} \\ c_{12} & c_{22} & c_{32} \\ c_{13} & c_{23} & c_{33} \end{pmatrix}$$

where

$$c_{11} = \begin{vmatrix} s + 0.394 & 0 \\ 0 & s + 0.02 \end{vmatrix} = (s + 0.394)(s + 0.02)$$

$$c_{12} = \begin{vmatrix} -0.268 & 0 \\ -0.227 & s + 0.02 \end{vmatrix} = -0.268(s + 0.02)$$

$$c_{13} = \begin{vmatrix} -0.268 & s + 0.394 \\ -0.227 & 0 \end{vmatrix} = -0.227(s + 0.394)$$

$$c_{21} = \begin{vmatrix} -0.209 & -0.02 \\ 0 & s + 0.02 \end{vmatrix} = -0.209(s + 0.02)$$

$$c_{22} = \begin{vmatrix} s + 0.435 & -0.02 \\ -0.227 & s + 0.02 \end{vmatrix} = (s + 0.435)(s + 0.02) - 0.00454 = s^2 + 0.455s + 0.00416$$

$$c_{23} = \begin{vmatrix} s + 0.435 & -0.209 \\ -0.227 & 0 \end{vmatrix} = -0.047443$$

$$c_{31} = \begin{vmatrix} -0.209 & -0.02 \\ s + 0.394 & 0 \end{vmatrix} = 0.02(s + 0.394)$$

$$c_{32} = \begin{vmatrix} s + 0.435 & -0.02 \\ -0.268 & 0 \end{vmatrix} = -0.00536$$

$$c_{33} = \begin{vmatrix} s + 0.435 & -0.209 \\ -0.268 & s + 0.394 \end{vmatrix} = (s + 0.435)(s + 0.394) - 0.268(0.209) = s^2 + 0.829s + 0.1154$$

$$(\mathbf{sI} - \mathbf{A})^{-1} = \frac{\text{Adj}(\mathbf{sI} - \mathbf{A})}{\det(\mathbf{sI} - \mathbf{A})} = \frac{\begin{bmatrix} (s + 0.394)(s + 0.02) & -0.209(s + 0.02) & 0.02(s + 0.394) \\ -0.268(s + 0.02) & s^2 + 0.455s + 0.0042 & -0.0054 \\ -0.227(s + 0.394) & -0.0474 & s^2 + 0.829s + 0.1154 \end{bmatrix}}{(s + 0.004)(s + 0.19)(s + 0.66)}$$

$$\mathbf{C}(\mathbf{sI} - \mathbf{A})^{-1} = \frac{[(s + 0.394)(s + 0.02) \quad -0.209(s + 0.02) \quad 0.02(s + 0.394)]}{3333.33(s + 0.004)(s + 0.19)(s + 0.66)}$$

$$\frac{Y(s)}{U(s)} = \mathbf{C}(\mathbf{sI} - \mathbf{A})^{-1} \mathbf{B} = \frac{(s + 0.02)(s + 0.394)}{3333.33(s + 0.004)(s + 0.19)(s + 0.66)}$$

**b.**

```
>> A=[-0.435 0.209 0.02; 0.268 -0.394 0; 0.227 0 -0.02]
```

A =

```
-0.4350  0.2090  0.0200  
0.2680 -0.3940   0  
0.2270   0 -0.0200
```

```
>> B = [1;0;0]
```

B =

```
1  
0  
0
```

```
>> C = [0.0003 0 0]
```

C =

```
1.0e-003 *
```

```
0.3000   0   0
```

```
>> [n,d]=ss2tf(A,B,C,0)
```

```
n =
```

```
1.0e-003 *
```

```
0 0.3000 0.1242 0.0024
```

```
d =
```

```
1.0000 0.8490 0.1274 0.0005
```

```
>> roots(n)
```

```
ans =
```

```
-0.3940
```

```
-0.0200
```

```
>> roots(d)
```

```
ans =
```

```
-0.6560
```

```
-0.1889
```

```
-0.0042
```

25. By direct observation

$$\begin{bmatrix} \dot{x}_0 \\ \dot{x}_1 \\ \dot{x}_2 \\ \dot{x}_3 \\ \dot{x}_4 \end{bmatrix} = \begin{bmatrix} a_{00} & 0 & a_{02} & 0 & 0 \\ a_{10} & a_{11} & a_{12} & 0 & 0 \\ a_{20} & a_{21} & a_{22} & a_{23} & a_{24} \\ 0 & 0 & a_{32} & a_{33} & 0 \\ 0 & 0 & a_{42} & 0 & a_{44} \end{bmatrix} \begin{bmatrix} x_0 \\ x_1 \\ x_2 \\ x_3 \\ x_4 \end{bmatrix} + \begin{bmatrix} 1 \\ 0 \\ 0 \\ 0 \\ 0 \end{bmatrix} d_0$$

26.

a.

```
>> A=[-0.038 0.896 0 0.0015; 0.0017 -0.092 0 -0.0056; 1 0 0 -3.086; 0 1 0 0]
```

A =

```
-0.0380  0.8960    0  0.0015
 0.0017 -0.0920    0 -0.0056
 1.0000    0    0 -3.0860
    0  1.0000    0    0
```

```
>> B = [-0.0075 -0.023; 0.0017 -0.0022; 0 0; 0 0]
```

B =

```
-0.0075 -0.0230
 0.0017 -0.0022
    0    0
    0    0
```

```
>> C = [0 0 1 0; 0 0 0 1]
```

3-32 Chapter 3: Modeling in the Time Domain

C =

```
0 0 1 0
0 0 0 1
```

```
>> [num,den] = ss2tf(A,B,C,zeros(2),1)
```

num =

```
0 0.0000 -0.0075 -0.0044 -0.0002
0 0 0.0017 0.0001 0
```

den =

```
1.0000 0.1300 0.0076 0.0002 0
```

```
>> [num,den] = ss2tf(A,B,C,zeros(2),2)
```

num =

```
0 -0.0000 -0.0230 0.0027 0.0002
0 -0.0000 -0.0022 -0.0001 0
```

den =

```
1.0000 0.1300 0.0076 0.0002 0
```



b.

From the MATLAB results

$$\frac{z}{\delta_B}(s) = \frac{-(0.0075s^2 + 0.0044s + 0.0002)}{s(s^3 + 0.13s^2 + 0.0076s + 0.0002)}$$

$$\frac{\theta}{\delta_B}(s) = \frac{0.0017s + 0.0001}{s^3 + 0.13s^2 + 0.0076s + 0.0002}$$

$$\frac{z}{\delta_S}(s) = \frac{-0.023s^2 + 0.0027s + 0.0002}{s(s^3 + 0.13s^2 + 0.0076s + 0.0002)}$$

$$\frac{\theta}{\delta_S}(s) = \frac{-(0.0022s + 0.0001)}{s^3 + 0.13s^2 + 0.0076s + 0.0002}$$

27.

The transfer function is divided into two parts:

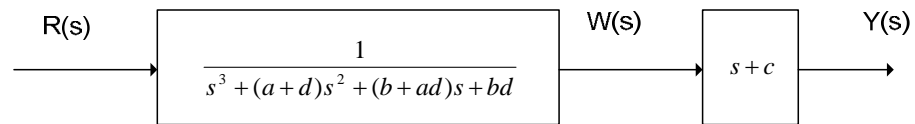

So we have

$$\frac{W(s)}{R(s)} = \frac{1}{s^3 + (a+d)s^2 + (b+ad)s + bd} \quad \text{and} \quad \frac{Y(s)}{W(s)} = s + c$$

In time domain

$$\ddot{w} + (a+d)\dot{w} + (b+ad)w + bdw = r \quad \text{and} \quad \dot{w} + cw = y$$

Define the state variables as

$$x_1 = w$$

$$x_2 = \dot{w} = \dot{x}_1$$

$$x_3 = \ddot{w} = \dot{x}_2$$

So we can write

$$\ddot{w} = \dot{x}_3 = r - bdx_1 - (b + ad)x_2 - (a + d)x_3 \text{ and } y = cx_1 + x_2$$

In matrix form these equations are:

$$\begin{bmatrix} \dot{x}_1 \\ \dot{x}_2 \\ \dot{x}_3 \end{bmatrix} = \begin{bmatrix} 0 & 1 & 0 \\ 0 & 0 & 1 \\ -bd & -(b + ad) & -(a + d) \end{bmatrix} \begin{bmatrix} x_1 \\ x_2 \\ x_3 \end{bmatrix} + \begin{bmatrix} 0 \\ 0 \\ 1 \end{bmatrix} r$$

$$y = \begin{bmatrix} c & 1 & 0 \end{bmatrix} \begin{bmatrix} x_1 \\ x_2 \\ x_3 \end{bmatrix}$$

28.

a.

$$G(s) = \mathbf{C}(s\mathbf{I} - \mathbf{A})^{-1}\mathbf{B} = 7(s + 5)^{-1}3 = \frac{21}{(s + 5)}$$

b.

$$\begin{aligned} G(s) &= \mathbf{C}(s\mathbf{I} - \mathbf{A})^{-1}\mathbf{B} = \begin{bmatrix} 7 & 0 \end{bmatrix} \begin{bmatrix} s+5 & 0 \\ 0 & s+1 \end{bmatrix}^{-1} \begin{bmatrix} 3 \\ 1 \end{bmatrix} = \begin{bmatrix} 7 & 0 \end{bmatrix} \begin{bmatrix} \frac{1}{s+5} & 0 \\ 0 & \frac{1}{s+1} \end{bmatrix} \begin{bmatrix} 3 \\ 1 \end{bmatrix} \\ &= \begin{bmatrix} \frac{7}{s+5} & 0 \end{bmatrix} \begin{bmatrix} 3 \\ 1 \end{bmatrix} = \frac{21}{s+5} \end{aligned}$$

$$\begin{aligned}
 \text{c) } G(s) &= \mathbf{C}(s\mathbf{I} - \mathbf{A})^{-1}\mathbf{B} = [7 \quad 3] \begin{bmatrix} s+5 & 0 \\ 0 & s+1 \end{bmatrix}^{-1} \begin{bmatrix} 3 \\ 0 \end{bmatrix} = [7 \quad 3] \begin{bmatrix} \frac{1}{s+5} & 0 \\ 0 & \frac{1}{s+1} \end{bmatrix} \begin{bmatrix} 3 \\ 0 \end{bmatrix} \\
 &= [7 \quad 0] \begin{bmatrix} \frac{3}{s+5} \\ 0 \end{bmatrix} = \frac{21}{s+5}
 \end{aligned}$$

29.

a.

$$\frac{dm_{SO}}{dt} = k_{O1}m_A(t) - (k_{O2} + k_{O3})m_{SO}(t) + k_{O4}m_{IDO}(t)$$

$$\frac{dm_{IDO}}{dt} = k_{O3}m_{SO}(t) - k_{O4}m_{IDO}(t)$$

$$\frac{dm_V}{dt} = k_{L1}m_A(t) - (k_{L2} + k_{L3})m_V(t)$$

$$\frac{dm_S}{dt} = k_{L3}m_V(t) - k_{L4}m_S(t)$$

b.

$$\begin{bmatrix} \dot{m}_A \\ \dot{m}_{SO} \\ \dot{m}_{IDO} \\ \dot{m}_V \\ \dot{m}_S \end{bmatrix} = \begin{bmatrix} -(k_{O1} + k_{L1}) & k_{O2} & 0 & k_{L2} & k_{L4} \\ k_{O2} & -(k_{O2} + k_{O3}) & k_{O4} & 0 & 0 \\ 0 & k_{O2} & -k_{O4} & 0 & 0 \\ k_{L1} & 0 & 0 & -(k_{L2} + k_{L3}) & 0 \\ 0 & 0 & 0 & k_{L2} & -k_{L4} \end{bmatrix} \begin{bmatrix} m_A \\ m_{SO} \\ m_{IDO} \\ m_V \\ m_S \end{bmatrix} + \begin{bmatrix} 1 \\ 0 \\ 0 \\ 0 \\ 0 \end{bmatrix} u_E(t)$$

$$\mathbf{y} = \begin{bmatrix} 1 & 0 & 0 & 0 & 0 \end{bmatrix} \begin{bmatrix} m_A \\ m_{SO} \\ m_{IDO} \\ m_V \\ m_S \end{bmatrix}$$

30. Writing the equations of motion,

$$\begin{aligned} M_f \frac{d^2 y_f}{dt^2} + (f_{vf} + f_{vh}) \frac{dy_f}{dt} + K_h y_f - f_{vh} \frac{dy_h}{dt} - K_h y_h &= f_{up}(t) \\ -f_{vh} \frac{dy_f}{dt} - K_h y_f + M_h \frac{d^2 y_h}{dt^2} + f_{vh} \frac{dy_h}{dt} + (K_h + K_s) y_h - K_s y_{cat} &= 0 \\ -K_s y_h + (K_s + K_{ave}) y_{cat} &= 0 \end{aligned}$$

The last equation says that

$$y_{cat} = \frac{K_s}{(K_s + K_{ave})} y_h$$

Defining state variables for the first two equations of motion,

$$x_1 = y_h; \quad x_2 = \dot{y}_h; \quad x_3 = y_f; \quad x_4 = \dot{y}_f$$

Solving for the highest derivative terms in the first two equations of motion yields,

$$\begin{aligned} \frac{d^2 y_f}{dt^2} &= -\frac{(f_{vf} + f_{vh})}{M_f} \frac{dy_f}{dt} - \frac{K_h}{M_f} y_f + \frac{f_{vh}}{M_f} \frac{dy_h}{dt} + \frac{K_h}{M_f} y_h + \frac{1}{M_f} f_{up}(t) \\ \frac{d^2 y_h}{dt^2} &= \frac{f_{vh}}{M_h} \frac{dy_f}{dt} + \frac{K_h}{M_h} y_f - \frac{f_{vh}}{M_h} \frac{dy_h}{dt} - \frac{(K_h + K_s)}{M_h} y_h + \frac{K_s}{M_h} y_{cat} \end{aligned}$$

Writing the state equations,

$$\begin{aligned} \dot{x}_1 &= x_2 \\ \dot{x}_2 &= \frac{f_{vh}}{M_h} x_4 + \frac{K_h}{M_h} x_3 - \frac{f_{vh}}{M_h} x_2 - \frac{(K_h + K_s)}{M_h} x_1 + \frac{K_s}{M_h} \frac{K_s}{(K_s + K_{ave})} x_1 \\ \dot{x}_3 &= x_4 \\ \dot{x}_4 &= -\frac{(f_{vf} + f_{vh})}{M_f} x_4 - \frac{K_h}{M_f} x_3 + \frac{f_{vh}}{M_f} x_2 + \frac{K_h}{M_f} x_1 + \frac{1}{M_f} f_{up}(t) \end{aligned}$$

The output is  $y_h - y_{cat}$ . Therefore,

$$y = y_h - y_{cat} = y_h - \frac{K_s}{(K_s + K_{ave})} y_h = \frac{K_{ave}}{(K_s + K_{ave})} x_1$$

Simplifying, rearranging, and putting the state equations in vector-matrix form yields,

$$\dot{\mathbf{x}} = \begin{bmatrix} 0 & 1 & 0 & 0 \\ \frac{1}{M_h} \left( \frac{K_s^2}{(K_s + K_{ave})} - (K_h + K_s) \right) & -\frac{f_{vh}}{M_h} & \frac{K_h}{M_h} & \frac{f_{vh}}{M_h} \\ 0 & 0 & 0 & 1 \\ \frac{K_h}{M_f} & \frac{f_{vh}}{M_f} & -\frac{K_h}{M_f} & -\frac{(f_{vf} + f_{vh})}{M_f} \end{bmatrix} \mathbf{x} + \begin{bmatrix} 0 \\ 0 \\ 0 \\ \frac{1}{M_f} \end{bmatrix} f_{up}(t)$$

$$y = \begin{bmatrix} \frac{K_{ave}}{(K_s + K_{ave})} & 0 & 0 & 0 \end{bmatrix} \mathbf{x}$$

Substituting numerical values,

$$\dot{\mathbf{x}} = \begin{bmatrix} 0 & 1 & 0 & 0 \\ -9353 & -14.29 & 769.2 & 14.29 \\ 0 & 0 & 0 & 1 \\ 406 & 7.558 & -406 & -9.302 \end{bmatrix} \mathbf{x} + \begin{bmatrix} 0 \\ 0 \\ 0 \\ 0.0581 \end{bmatrix} f_{up}(t)$$

$$y = [0.9491 \quad 0 \quad 0 \quad 0] \mathbf{x}$$

31.

a.

$$\underline{f_1 = s - dT - (1 - u_1)\beta Tv}$$

$$\underline{f_2 = (1 - u_1)\beta Tv - \mu T^*}$$

$$\underline{f_3 = (1 - u_2)kT^* - cv}$$

$$\underline{\left. \frac{\partial f_1}{\partial T} \right|_0 = -d - (1 - u_1)\beta v \Big|_0 = -d - (1 - u_{10})\beta v_0}$$

$$\frac{\partial f_1}{\partial T^*} \Big|_0 = 0$$

---

$$\frac{\partial f_1}{\partial v} \Big|_0 = (1 - u_1)\beta v \Big|_0 = (1 - u_{10})\beta v_0$$

---

$$\frac{\partial f_2}{\partial T} \Big|_0 = (1 - u_1)\beta v \Big|_0 = (1 - u_{10})\beta v_0$$

---

$$\frac{\partial f_2}{\partial T^*} \Big|_0 = -\mu$$

---

$$\frac{\partial f_2}{\partial v} \Big|_0 = (1 - u_1)\beta T \Big|_0 = (1 - u_{10})\beta T_0$$

---

$$\frac{\partial f_3}{\partial T} \Big|_0 = 0$$

---

$$\frac{\partial f_3}{\partial T^*} \Big|_0 = (1 - u_{20})k$$

---

$$\frac{\partial f_3}{\partial v} \Big|_0 = -c$$

---

$$\frac{\partial f_1}{\partial u_1} \Big|_0 = \beta T_0 v_0$$

---

$$\frac{\partial f_1}{\partial u_2} \Big|_0 = 0$$

---

$$\frac{\partial f_2}{\partial u_1} \Big|_0 = -\beta T_0 v_0$$

---

$$\frac{\partial f_2}{\partial u_2} \Big|_0 = 0$$

---

$$\frac{\partial f_3}{\partial u_1} \Big|_0 = 0$$

---

$$\frac{\partial f_3}{\partial u_2} \Big|_0 = -kT_0^*$$

---

Then just by direct substitution.

b.

Substituting values one gets:

$$\begin{bmatrix} \dot{T} \\ \dot{T}^* \\ \dot{v} \end{bmatrix} = \begin{bmatrix} -(d + \beta v_0) & 0 & -\beta T_0 \\ \beta v_0 & -\mu & \beta T_0 \\ 0 & k & -c \end{bmatrix} \begin{bmatrix} T \\ T^* \\ v \end{bmatrix} + \begin{bmatrix} \beta T_0 v_0 & 0 \\ -\beta T_0 v_0 & 0 \\ 0 & -k T_0^* \end{bmatrix} \begin{bmatrix} u_1 \\ u_2 \end{bmatrix}$$

$$y = \begin{bmatrix} 0 & 0 & 1 \end{bmatrix} \begin{bmatrix} T \\ T^* \\ v \end{bmatrix}$$

32.

- a. The following basic equations characterize the relationships between the state, input, and output variables for the HEV common forward path of the figure:

$$u_a(t) = K_A \cdot u_c(t)$$

$$L_a \cdot \dot{I}_a + R_a \cdot I_a(t) = u_a(t) - e_b(t) = K_A u_c(t) - k_b \cdot \omega(t) \quad (1)$$

$$J_{tot} \cdot \dot{\omega} = T(t) - T_f(t) - T_c(t), \text{ where } J_{tot} = J_m + J_{veh} + J_w,$$

$$T(t) = k_t \cdot I_a(t), \quad T_f(t) = k_f \cdot \omega(t)$$

- b. Given that the state variables are the motor armature current,  $I_a(t)$ , and angular speed,  $\omega(t)$ , we re-write the above equations as:

$$\dot{I}_a = -\frac{R_a}{L_a} \cdot I_a(t) - \frac{k_b}{L_a} \cdot \omega(t) + \frac{K_A}{L_a} u_c(t) \quad (2)$$

$$\dot{\omega} = \frac{k_t}{J_{tot}} I_a(t) - \frac{k_f}{J_{tot}} \omega(t) - \frac{1}{J_{tot}} T_c(t) \quad (3)$$

In matrix form, the resulting state-space equations are:

$$\begin{bmatrix} \dot{I}_a \\ \dot{\omega} \end{bmatrix} = \begin{bmatrix} -\frac{R_a}{L_a} & -\frac{k_b}{L_a} \\ \frac{k_t}{J_{tot}} & -\frac{k_f}{J_{tot}} \end{bmatrix} \begin{bmatrix} I_a \\ \omega \end{bmatrix} + \begin{bmatrix} \frac{K_A}{L_a} & 0 \\ 0 & -\frac{1}{J_{tot}} \end{bmatrix} \begin{bmatrix} u_c \\ T_c \end{bmatrix} \quad (4)$$

$$\begin{bmatrix} I_a \\ \omega \end{bmatrix} = \begin{bmatrix} 1 & 0 \\ 0 & 1 \end{bmatrix} \begin{bmatrix} I_a \\ \omega \end{bmatrix} \quad (5)$$



# F O U R

## Time Response

### SOLUTIONS TO CASE STUDIES CHALLENGES

#### Antenna Control: Open-Loop Response

The forward transfer function for angular velocity is,

$$G(s) = \frac{\omega_0(s)}{V_p(s)} = \frac{24}{(s+150)(s+1.32)}$$

a.  $\omega_0(t) = A + Be^{-150t} + Ce^{-1.32t}$

b.  $G(s) = \frac{24}{s^2+151.32s+198}$ . Therefore,  $2\zeta\omega_n=151.32$ ,  $\omega_n = 14.07$ , and  $\zeta = 5.38$ .

c.  $\omega_0(s) = \frac{24}{s(s^2+151.32s+198)} =$

$$\frac{24}{s(s+150)(s+1.32)} = 0.12121 \frac{1}{s} + 0.0010761 \frac{1}{s+150} - 0.12229 \frac{1}{s+1.32}$$

Therefore,  $\omega_0(t) = 0.12121 + .0010761 e^{-150t} - 0.12229e^{-1.32t}$ .

d. Using  $G(s)$ ,

$$\ddot{\omega}_0 + 151.32 \dot{\omega}_0 + 198\omega_0 = 24v_p(t)$$

Defining,

$$x_1 = \omega_0$$

$$x_2 = \dot{\omega}_0$$

Thus, the state equations are,

$$\dot{x}_1 = x_2$$

$$\dot{x}_2 = -198x_1 - 151.32x_2 + 24v_p(t)$$

$$y = x_1$$

In vector-matrix form,

$$\dot{\mathbf{x}} = \begin{bmatrix} 0 & 1 \\ -198 & -151.32 \end{bmatrix} \mathbf{x} + \begin{bmatrix} 0 \\ 24 \end{bmatrix} v_p(t); y = \begin{bmatrix} 1 & 0 \end{bmatrix} \mathbf{x}$$

e.

**Program:**

```
'Case Study 1 Challenge (e)'  
num=24;  
den=poly([-150 -1.32]);  
G=tf(num,den)  
step(G)
```

**Computer response:**

ans =

Case Study 1 Challenge (e)

Transfer function:

$$\frac{24}{s^2 + 151.3 s + 198}$$

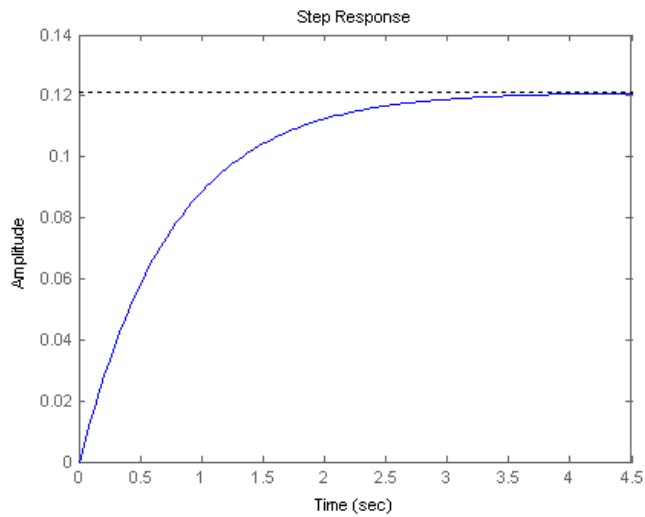

**Ship at Sea: Open-Loop Response**

a. Assuming a second-order approximation:  $\omega_n^2 = 2.25$ ,  $2\zeta\omega_n = 0.5$ . Therefore  $\zeta = 0.167$ ,  $\omega_n = 1.5$ .

$$T_s = \frac{4}{\zeta\omega_n} = 16; T_P = \frac{\pi}{\omega_n\sqrt{1-\zeta^2}} = 2.12;$$

$$\%OS = e^{-\zeta\pi} / \sqrt{1-\zeta^2} \times 100 = 58.8\%; \omega_n T_r = 1.169 \text{ therefore, } T_r = 0.77.$$

$$\begin{aligned} \text{b. } \theta(s) &= \frac{2.25}{s(s^2 + 0.5s + 2.25)} = \frac{1}{s} - \frac{s + 0.5}{s^2 + 0.5s + 2.25} \\ &= \frac{1}{s} - \frac{(s + 0.25) + \frac{0.25}{\sqrt{2.1875}}}{(s + 0.25)^2 + 2.1875} \end{aligned}$$

$$= \frac{1}{s} - \frac{(s + 0.25) + 0.16903 \cdot 1.479}{(s + 0.25)^2 + 2.1875}$$

Taking the inverse Laplace transform,

$$\theta(t) = 1 - e^{-0.25t} (\cos 1.479t + 0.16903 \sin 1.479t)$$

**c.**

**Program:**

```
'Case Study 2 Challenge (C)'  
'(a)'  
numg=2.25;  
deng=[1 0.5 2.25];  
G=tf(numg,deng)  
omegan=sqrt(deng(3))  
zeta=deng(2)/(2*omegan)  
Ts=4/(zeta*omegan)  
Tp=pi/(omegan*sqrt(1-zeta^2))  
pos=exp(-zeta*pi/sqrt(1-zeta^2))*100  
t=0:.1:2;  
[y,t]=step(G,t);  
Tlow=interp1(y,t,.1);  
Thi=interp1(y,t,.9);  
Tr=Thi-Tlow  
'(b)'  
numc=2.25*[1 2];  
denc=conv(poly([0 -3.57]),[1 2 2.25]);  
[K,p,k]=residue(numc,denc)  
'(c)'  
[y,t]=step(G);  
plot(t,y)  
title('Roll Angle Response')  
xlabel('Time(seconds)')  
ylabel('Roll Angle(radians)')
```

**Computer response:**

ans =

Case Study 2 Challenge (C)

ans =

(a)

```
Transfer function:  
      2.25  
-----  
s^2 + 0.5 s + 2.25
```

omegan =

1.5000

zeta =

0.1667

Ts =

16

#### 4-4 Chapter 4: Time Response

Tp =

2.1241

pos =

58.8001

Tr =

0.7801

ans =

(b)

K =

0.1260  
-0.3431 + 0.1058i  
-0.3431 - 0.1058i  
0.5602

p =

-3.5700  
-1.0000 + 1.1180i  
-1.0000 - 1.1180i  
0

k =

[]

ans =

(c)

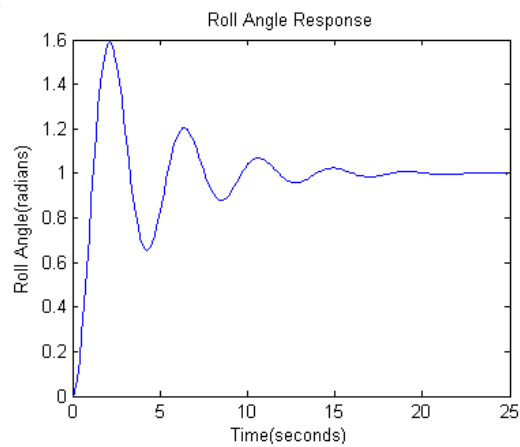

## ANSWERS TO REVIEW QUESTIONS

1. Time constant
2. The time for the step response to reach 63% of its final value
3. The input pole
4. The system poles
5. The radian frequency of a sinusoidal response
6. The time constant of an exponential response
7. Natural frequency is the frequency of the system with all damping removed; the damped frequency of oscillation is the frequency of oscillation with damping in the system.
8. Their damped frequency of oscillation will be the same.
9. They will all exist under the same exponential decay envelop.
10. They will all have the same percent overshoot and the same shape although differently scaled in time.
11.  $\zeta$ ,  $\omega_n$ ,  $T_P$ , %OS,  $T_S$
12. Only two since a second-order system is completely defined by two component parameters
13. (1) Complex, (2) Real, (3) Multiple real
14. Pole's real part is large compared to the dominant poles, (2) Pole is near a zero
15. If the residue at that pole is much smaller than the residues at other poles
16. No; one must then use the output equation
17. The Laplace transform of the state transition matrix is  $(s\mathbf{I} - \mathbf{A})^{-1}$
18. Computer simulation
19. Pole-zero concepts give one an intuitive feel for the problem.
20. State equations, output equations, and initial value for the state-vector
21.  $\text{Det}(s\mathbf{I} - \mathbf{A}) = 0$

## SOLUTIONS TO PROBLEMS

1.
  - a. Overdamped Case:

$$C(s) = \frac{9}{s(s^2 + 9s + 9)}$$

Expanding into partial fractions,

$$C(s) = \frac{9}{s(s+7.854)(s+1.146)} = \frac{1}{s} + \frac{0.171}{(s+7.854)} - \frac{1.171}{(s+1.146)}$$

Taking the inverse Laplace transform,

$$c(t) = 1 + 0.171 e^{-7.854t} - 1.171 e^{-1.146t}$$

b. Underdamped Case:

$$C(s) = \frac{9}{s(s^2 + 3s + 9)} = \frac{K_1}{s} + \frac{K_2s + K_3}{(s^2 + 3s + 9)}$$

$$K_1 = \left. \frac{9}{(s^2 + 3s + 9)} \right|_{s \rightarrow 0} = 1$$

$K_2$  and  $K_3$  can be found by clearing fractions with  $K_1$  replaced by its value. Thus,

$$9 = (s^2 + 3s + 9) + (K_2s + K_3)s$$

or

$$9 = s^2 + 3s + 9 + K_2s^2 + K_3s$$

Hence  $K_2 = -1$  and  $K_3 = -3$ . Thus,

$$C(s) = \frac{1}{s} - \frac{(s + \frac{3}{2})}{(s + \frac{3}{2})^2 + \frac{27}{4}}$$

$$C(s) = \frac{1}{s} - \frac{(s + \frac{3}{2})}{(s + \frac{3}{2})^2 + \frac{27}{4}} - \frac{\frac{3}{2}}{(s + \frac{3}{2})^2 + \frac{27}{4}}$$

$$C(s) = \frac{1}{s} - \frac{(s + \frac{3}{2})}{(s + \frac{3}{2})^2 + \frac{27}{4}} - \frac{\frac{3}{\sqrt{27}} \sqrt{\frac{27}{4}}}{(s + \frac{3}{2})^2 + \frac{27}{4}}$$

$$c(t) = 1 - e^{-\frac{3}{2}t} \cos \sqrt{\frac{27}{4}} t - \frac{3}{\sqrt{27}} e^{-\frac{3}{2}t} \sin \sqrt{\frac{27}{4}} t$$

$$c(t) = 1 - \frac{2}{\sqrt{3}} e^{-3t/2} \cos(\sqrt{\frac{27}{4}} t - \phi)$$

$$= 1 - 1.155 e^{-1.5t} \cos(2.598t - \phi)$$

where

$$\phi = \arctan\left(\frac{3}{\sqrt{27}}\right) = 30^\circ$$

c. Oscillatory Case:

$$C(s) = \frac{9}{s(s^2 + 9)}$$

$$C(s) = \frac{9}{s(s^2 + 9)} = \frac{K_1}{s} + \frac{K_2s + K_3}{(s^2 + 9)}$$

The evaluation of the constants in the numerator are found the same way as they were for the underdamped case. The results are  $K_2 = -1$  and  $K_3 = 0$ . Hence,

$$C(s) = \frac{1}{s} - \frac{s}{(s^2 + 9)}$$

Therefore,

$$c(t) = 1 - \cos 3t$$

d. Critically Damped

$$C(s) = \frac{9}{s(s^2 + 6s + 9)}$$

$$C(s) = \frac{9}{s(s^2 + 6s + 9)} = \frac{K_1}{s} + \frac{K_2}{(s + 3)^2} + \frac{K_3}{(s + 3)}$$

The constants are then evaluated as

$$K_1 = \left. \frac{9}{(s^2 + 6s + 9)} \right|_{s \rightarrow 0} = 1; \quad K_2 = \left. \frac{9}{s} \right|_{s \rightarrow -3} = -3; \quad K_3 = \left. \frac{d}{ds} \left( \frac{9}{s} \right) \right|_{s \rightarrow -3} = -1$$

Now, the transform of the response is

$$C(s) = \frac{9}{s(s^2 + 6s + 9)} = \frac{1}{s} - \frac{3}{(s + 3)^2} - \frac{1}{(s + 3)}$$

$$c(t) = 1 - 3te^{-3t} - e^{-3t}$$

2.

a.  $C(s) = \frac{5}{s(s+5)} = \frac{1}{s} - \frac{1}{s+5}$ . Therefore,  $c(t) = 1 - e^{-5t}$ .

Also,  $T = \frac{1}{5}$ ,  $T_r = \frac{2.2}{a} = \frac{2.2}{5} = 0.44$ ,  $T_s = \frac{4}{a} = \frac{4}{5} = 0.8$ .

b.  $C(s) = \frac{20}{s(s+20)} = \frac{1}{s} - \frac{1}{s+20}$ . Therefore,  $c(t) = 1 - e^{-20t}$ . Also,  $T = \frac{1}{20}$ ,

$T_r = \frac{2.2}{a} = \frac{2.2}{20} = 0.11$ ,  $T_s = \frac{4}{a} = \frac{4}{20} = 0.2$ .

3.

**Program:**

```
'(a)'  
num=5;  
den=[1 5];  
Ga=tf(num,den)  
subplot(1,2,1)  
step(Ga)  
title('(a)')  
'(b)'  
num=20;  
den=[1 20];  
Gb=tf(num,den)  
subplot(1,2,2)  
step(Gb)  
title('(b)')
```

**Computer response:**

ans =

(a)

Transfer function:

$$\frac{5}{s + 5}$$

ans =

(b)

Transfer function:

$$\frac{20}{s + 20}$$

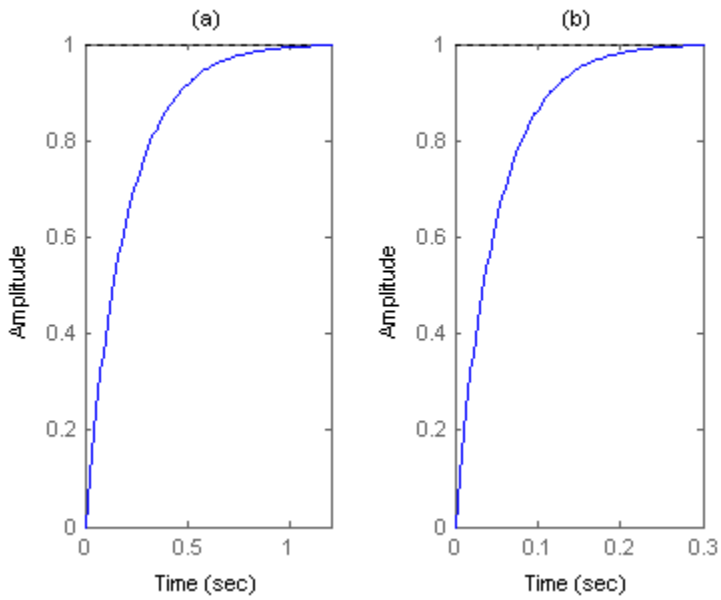



4.

Using voltage division,  $\frac{V_C(s)}{V_i(s)} = \frac{1/RC}{s + \frac{1}{RC}} = \frac{0.703}{s + 0.703}$ . Since  $V_i(s) = \frac{5}{s}$

$$V_c(s) = \frac{5}{s} \left( \frac{0.703}{s + 0.703} \right) = \frac{5}{s} - \frac{5}{s + 0.703}.$$

Therefore  $v_c(t) = 5 - 5e^{-0.703t}$ . Also,

$$T = \frac{1}{0.703} = 1.422; T_r = \frac{2.2}{0.703} = 3.129; T_s = \frac{4}{0.703} = 5.69.$$

5.

**Program:**

```
clf
num=0.703;
den=[1 0.703];
G=tf(num,den)
step(5*G)
```

**Computer response:**

```
Transfer function:
    0.703
-----
s + 0.703
```

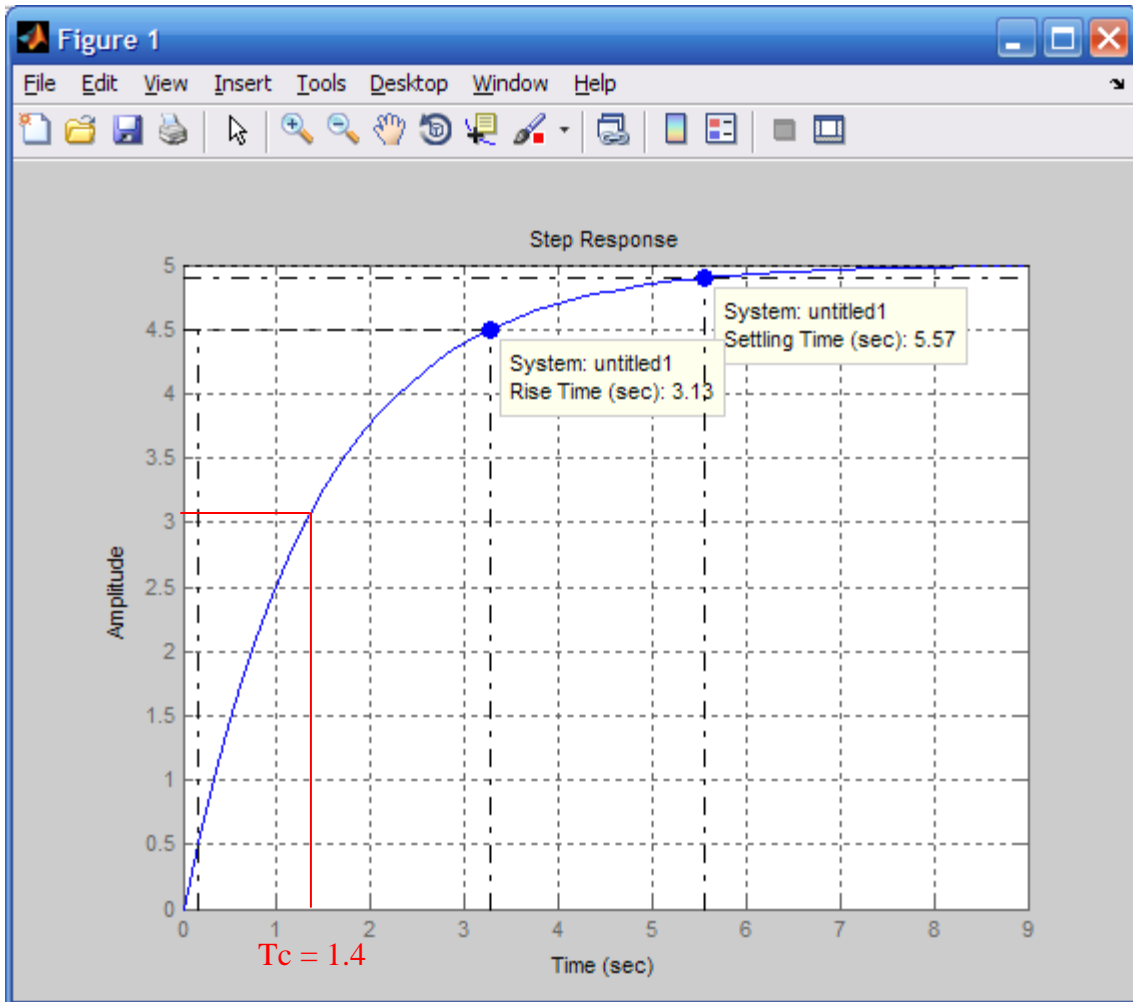

6.

Writing the equation of motion,

$$(Ms^2 + 6s)X(s) = F(s)$$

Thus, the transfer function is,

$$\frac{X(s)}{F(s)} = \frac{1}{Ms^2 + 6s}$$

Differentiating to yield the transfer function in terms of velocity,

$$\frac{sX(s)}{F(s)} = \frac{1}{Ms + 6} = \frac{1/M}{s + \frac{6}{M}}$$

Thus, the settling time,  $T_s$ , and the rise time,  $T_r$ , are given by

$$T_s = \frac{4}{6/M} = \frac{2}{3}M = 0.667M; \quad T_r = \frac{2.2}{6/M} = \frac{1.1}{3}M = 0.367M$$

7.

**Program:**

```

Clf
M=1
num=1/M;
den=[1 6/M];
G=tf(num,den)
step(G)
pause
M=2
num=1/M;
den=[1 6/M];
G=tf(num,den)
step(G)

```

**Computer response:**

M =

1

Transfer function:

$$\frac{1}{s + 6}$$

M =

2

Transfer function:

$$\frac{0.5}{s + 3}$$

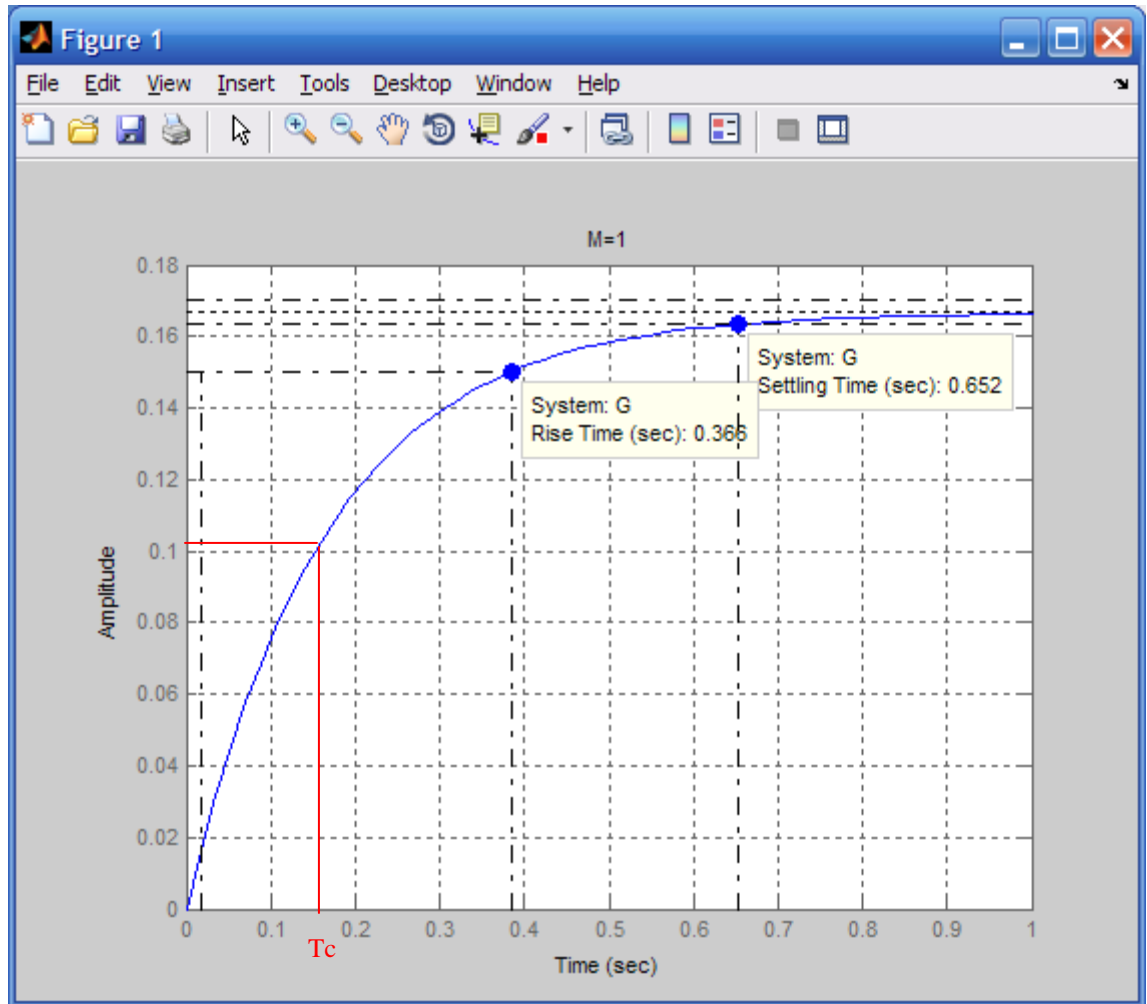

From plot, time constant = 0.16 s.

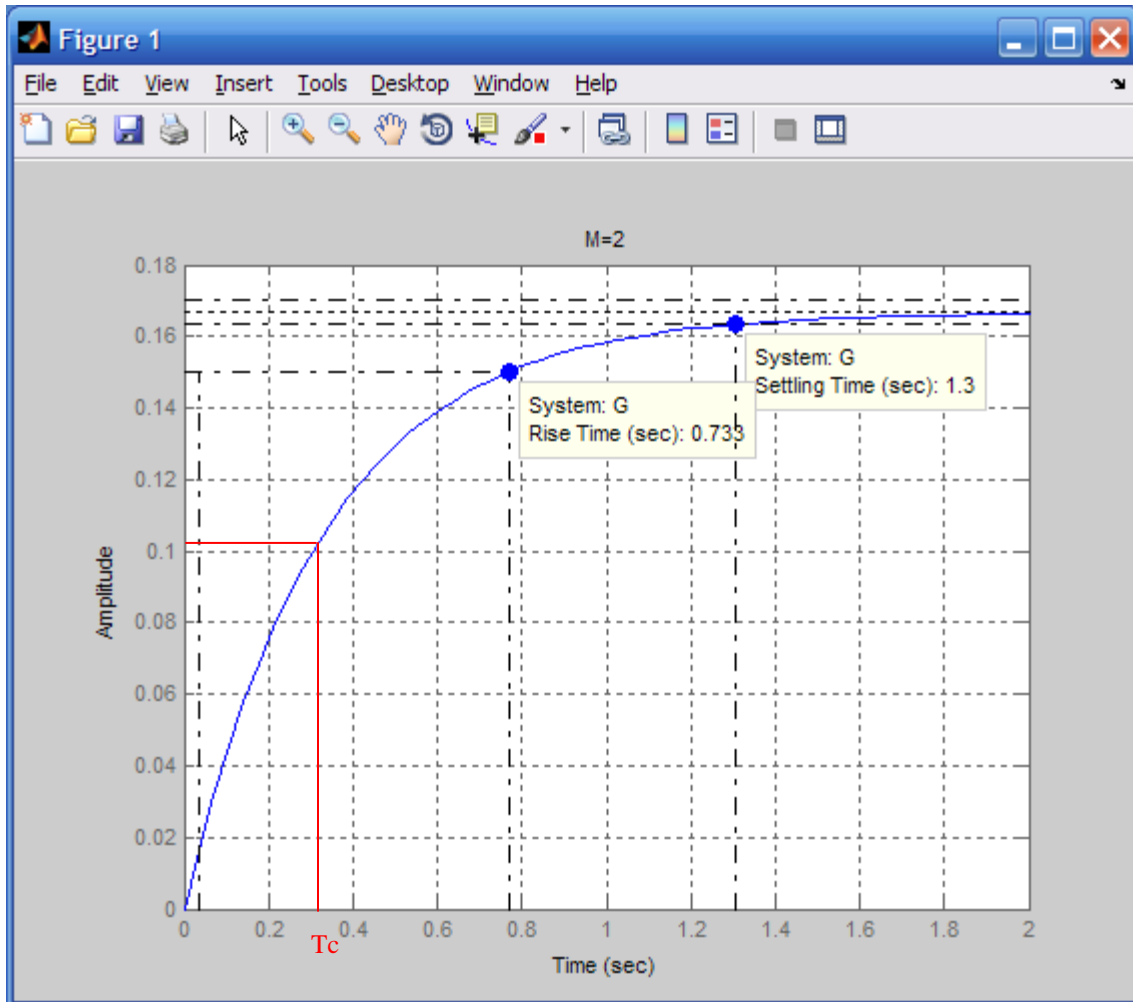

From plot, time constant = 0.33 s.

8.

a. Pole: -2;  $c(t) = A + Be^{-2t}$ ; first-order response.

b. Poles: -3, -6;  $c(t) = A + Be^{-3t} + Ce^{-6t}$ ; overdamped response.

c. Poles: -10, -20; Zero: -7;  $c(t) = A + Be^{-10t} + Ce^{-20t}$ ; overdamped response.

d. Poles:  $(-3+j3\sqrt{15})$ ,  $(-3-j3\sqrt{15})$ ;  $c(t) = A + Be^{-3t} \cos(3\sqrt{15}t + \phi)$ ; underdamped.

e. Poles:  $j3$ ,  $-j3$ ; Zero: -2;  $c(t) = A + B \cos(3t + \phi)$ ; undamped.

f. Poles: -10, -10; Zero: -5;  $c(t) = A + Be^{-10t} + Cte^{-10t}$ ; critically damped.

9.

**Program:**

```
p=roots([1 6 4 7 2])
```

**Computer response:**

```
p =
```

-5.4917  
 -0.0955 + 1.0671i  
 -0.0955 - 1.0671i  
 -0.3173

10.

$$G(s) = \mathbf{C} (s\mathbf{I} - \mathbf{A})^{-1} \mathbf{B}$$

$$\mathbf{A} = \begin{bmatrix} 8 & -4 & 1 \\ -3 & 2 & 0 \\ 5 & 7 & -9 \end{bmatrix}; \mathbf{B} = \begin{bmatrix} -4 \\ -3 \\ 4 \end{bmatrix}; \mathbf{C} = [2 \quad 8 \quad -3]$$

$$(s\mathbf{I} - \mathbf{A})^{-1} = \frac{1}{s^3 - s^2 - 91s + 67} \begin{bmatrix} (s-2)(s+9) & -(4s+29) & (s-2) \\ -(3s+27) & (s^2+s-77) & -3 \\ 5s-31 & 7s-76 & (s^2-10s+4) \end{bmatrix}$$

$$\text{Therefore, } G(s) = \frac{-44s^2 + 291s + 1814}{s^3 - s^2 - 91s + 67}.$$

Factoring the denominator, or using  $\det(s\mathbf{I} - \mathbf{A})$ , we find the poles to be 9.683, 0.7347, -9.4179.

11.

**Program:**

```
A=[8 -4 1;-3 2 0;5 7 -9]
B=[-4;-3;4]
C=[2 8 -3]
D=0
[numg,deng]=ss2tf(A,B,C,D,1);
G=tf(numg,deng)
poles=roots(deng)
```

**Computer response:**

A =

```
8    -4    1
-3    2    0
5     7   -9
```

B =

```
-4
-3
4
```

C =

$$2 \quad 8 \quad -3$$

D =

$$0$$

Transfer function:

$$-44 s^2 + 291 s + 1814$$

-----

$$s^3 - s^2 - 91 s + 67$$

poles =

$$-9.4179$$

$$9.6832$$

$$0.7347$$

**12.**

Writing the node equation at the capacitor,  $V_C(s) \left( \frac{1}{R_2} + \frac{1}{Ls} + Cs \right) + \frac{V_C(s) - V(s)}{R_1} = 0$ .

Hence,  $\frac{V_C(s)}{V(s)} = \frac{\frac{1}{R_1}}{\frac{1}{R_1} + \frac{1}{R_2} + \frac{1}{Ls} + Cs} = \frac{10s}{s^2 + 20s + 500}$ . The step response is  $\frac{10}{s^2 + 20s + 500}$ . The poles

are at

$-10 \pm j20$ . Therefore,  $v_C(t) = Ae^{-10t} \cos(20t + \phi)$ .

**13.****Program:**

```
num=[10 0];
den=[1 20 500];
G=tf(num,den)
step(G)
```

**Computer response:**

Transfer function:

$$10 s$$

$$s^2 + 20 s + 500$$

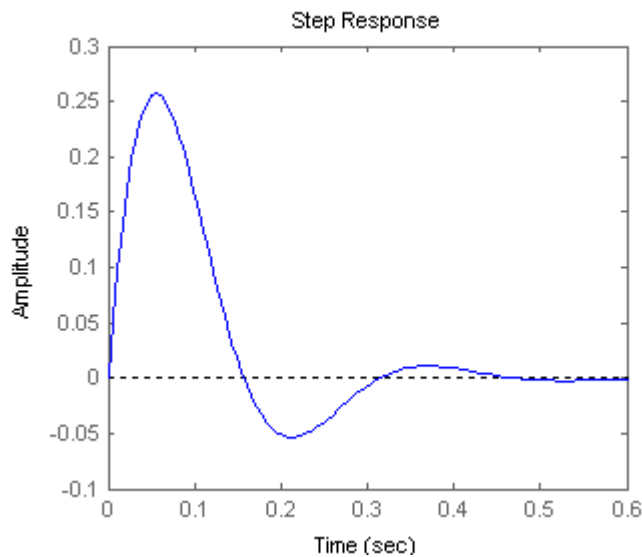

14.

The equation of motion is:  $(Ms^2 + f_v s + K_s)X(s) = F(s)$ . Hence,  $\frac{X(s)}{F(s)} = \frac{1}{Ms^2 + f_v s + K_s} = \frac{1}{s^2 + s + 5}$ .

The step response is now evaluated:  $X(s) = \frac{1}{s(s^2 + s + 5)} = \frac{1/5}{s} - \frac{\frac{1}{5}s + \frac{1}{5}}{(s + \frac{1}{2})^2 + \frac{19}{4}}$

$$\frac{\frac{1}{5}(s + \frac{1}{2}) + \frac{1}{5\sqrt{19}} \frac{\sqrt{19}}{2}}{(s + \frac{1}{2})^2 + \frac{19}{4}}$$

Taking the inverse Laplace transform,  $x(t) = \frac{1}{5} - \frac{1}{5} e^{-0.5t} \left( \cos \frac{\sqrt{19}}{2} t + \frac{1}{\sqrt{19}} \sin \frac{\sqrt{19}}{2} t \right)$   
 $= \frac{1}{5} \left[ 1 - 2\sqrt{\frac{5}{19}} e^{-0.5t} \cos \left( \frac{\sqrt{19}}{2} t - 12.92^\circ \right) \right]$ .

15.

$$C(s) = \frac{\omega_n^2}{s(s^2 + 2\zeta\omega_n s + \omega_n^2)} = \frac{1}{s} - \frac{s + 2\zeta\omega_n}{s^2 + 2\zeta\omega_n s + \omega_n^2} = \frac{1}{s} - \frac{s + 2\zeta\omega_n}{(s + \zeta\omega_n)^2 + \omega_n^2 - \zeta^2\omega_n^2}$$

$$= \frac{1}{s} - \frac{(s + \zeta\omega_n) + \zeta\omega_n}{(s + \zeta\omega_n)^2 + (\omega_n\sqrt{1 - \zeta^2})^2} = \frac{1}{s} - \frac{(s + \zeta\omega_n) + \frac{\zeta\omega_n}{\omega_n\sqrt{1 - \zeta^2}} \omega_n\sqrt{1 - \zeta^2}}{(s + \zeta\omega_n)^2 + (\omega_n\sqrt{1 - \zeta^2})^2}$$

Hence,  $c(t) = 1 - e^{-\zeta\omega_n t} \left( \cos \omega_n\sqrt{1 - \zeta^2} t + \frac{\zeta}{\sqrt{1 - \zeta^2}} \sin \omega_n\sqrt{1 - \zeta^2} t \right)$



$$= 1 - e^{-\zeta\omega_n t} \sqrt{1 + \frac{\zeta^2}{1-\zeta^2}} \cos(\omega_n \sqrt{1-\zeta^2} t - \phi) = 1 - e^{-\zeta\omega_n t} \frac{1}{\sqrt{1-\zeta^2}} \cos(\omega_n \sqrt{1-\zeta^2} t - \phi),$$

$$\text{where } \phi = \tan^{-1} \frac{\zeta}{\sqrt{1-\zeta^2}}$$

16.

%OS =  $e^{-\zeta\pi} / \sqrt{1-\zeta^2}$  x 100. Dividing by 100 and taking the natural log of both sides,

$$\ln\left(\frac{\%OS}{100}\right) = -\frac{\zeta\pi}{\sqrt{1-\zeta^2}}. \text{ Squaring both sides and solving for } \zeta^2, \zeta^2 = \frac{\ln^2\left(\frac{\%OS}{100}\right)}{\pi^2 + \ln^2\left(\frac{\%OS}{100}\right)}. \text{ Taking the}$$

$$\text{negative square root, } \zeta = \frac{-\ln\left(\frac{\%OS}{100}\right)}{\sqrt{\pi^2 + \ln^2\left(\frac{\%OS}{100}\right)}}.$$

17.

a.

$$C(s) = \frac{2}{s(s+2)}$$

$$C(s) = \frac{1}{s} - \frac{1}{s+2}$$

$$c(t) = 1 - e^{-2t}$$

b.

$$C(s) = \frac{5}{s(s+3)(s+6)}$$

$$C(s) = \frac{5}{18} \frac{1}{s} - \frac{5}{9} \frac{1}{s+3} + \frac{5}{18} \frac{1}{s+6}$$

$$c(t) = \frac{5}{18} - \frac{5}{9} e^{-3t} + \frac{5}{18} e^{-6t}$$

c.

$$C(s) = \frac{10(s+7)}{s(s+10)(s+20)}$$

$$C(s) = \frac{7}{20} \frac{1}{s} + \frac{3}{10} \frac{1}{s+10} - \frac{13}{20} \frac{1}{s+20}$$

$$c(t) = \frac{7}{20} + \frac{3}{10} e^{-10t} - \frac{13}{20} e^{-20t}$$

d.

$$C(s) = \frac{20}{s(s^2 + 6s + 144)}$$

$$C(s) = \frac{5}{36} \frac{1}{s} - \frac{5}{36} \frac{s+6}{s^2 + 6s + 144}$$

$$C(s) = \frac{5}{36} \frac{1}{s} - \frac{5}{36} \frac{(s+3) + \frac{3}{\sqrt{135}} \sqrt{135}}{(s+3)^2 + 135}$$

$$c(t) = \frac{5}{36} - \frac{5}{36} e^{-3t} \left( \cos[\sqrt{135}]t + \frac{3}{\sqrt{135}} \sin[\sqrt{135}]t \right)$$

e.

$$C(s) = \frac{s+2}{s(s^2+9)}$$

$$C(s) = \frac{2}{9} \frac{1}{s} + \frac{1}{9} \frac{-2s+9}{s^2+9}$$

$$C(s) = \frac{2}{9} \frac{1}{s} + \frac{1}{9} \frac{-2s+3.3}{s^2+9}$$

$$c(t) = \frac{2}{9} - \left( \frac{2}{9} \cos. 3t - \frac{1}{3} \sin. 3t \right)$$

f.

$$C(s) = \frac{s+5}{s(s+10)^2}$$

$$C(s) = \frac{1}{20} \frac{1}{s} - \frac{1}{20} \frac{1}{s+10} + \frac{1}{2} \frac{1}{(s+10)^2}$$

$$c(t) = \frac{1}{20} - \frac{1}{20} e^{-10t} + \frac{1}{2} t e^{-10t}$$

18.

a. N/A

b.  $s^2+9s+18$ ,  $\omega_n^2 = 18$ ,  $2\zeta\omega_n = 9$ , Therefore  $\zeta = 1.06$ ,  $\omega_n = 4.24$ , overdamped.c.  $s^2+30s+200$ ,  $\omega_n^2 = 200$ ,  $2\zeta\omega_n = 30$ , Therefore  $\zeta = 1.06$ ,  $\omega_n = 14.14$ , overdamped.d.  $s^2+6s+144$ ,  $\omega_n^2 = 144$ ,  $2\zeta\omega_n = 6$ , Therefore  $\zeta = 0.25$ ,  $\omega_n = 12$ , underdamped.e.  $s^2+9$ ,  $\omega_n^2 = 9$ ,  $2\zeta\omega_n = 0$ , Therefore  $\zeta = 0$ ,  $\omega_n = 3$ , undamped.f.  $s^2+20s+100$ ,  $\omega_n^2 = 100$ ,  $2\zeta\omega_n = 20$ , Therefore  $\zeta = 1$ ,  $\omega_n = 10$ , critically damped.

19.

$$X(s) = \frac{100^2}{s(s^2+100s+100^2)} = \frac{1}{s} - \frac{s+100}{(s+50)^2+7500} = \frac{1}{s} - \frac{(s+50)+50}{(s+50)^2+7500} = \frac{1}{s} - \frac{(s+50) + \frac{50}{\sqrt{7500}}\sqrt{7500}}{(s+50)^2+7500}$$

$$\text{Therefore, } x(t) = 1 - e^{-50t} \left( \cos\sqrt{7500} t + \frac{50}{\sqrt{7500}} \sin\sqrt{7500} t \right)$$

$$= 1 - \frac{2}{\sqrt{3}} e^{-50t} \cos \left( 50\sqrt{3} t - \tan^{-1} \frac{1}{\sqrt{3}} \right)$$

20.

a.  $\omega_n^2 = 16$  r/s,  $2\zeta\omega_n = 3$ . Therefore  $\zeta = 0.375$ ,  $\omega_n = 4$ .  $T_s = \frac{4}{\zeta\omega_n} = 2.667$  s;  $T_p = \frac{\pi}{\omega_n\sqrt{1-\zeta^2}} =$ 

$$0.8472 \text{ s; } \%OS = e^{-\zeta\pi} / \sqrt{1-\zeta^2} \times 100 = 28.06 \% ; \omega_n T_r = (1.76\zeta^3 - 0.417\zeta^2 + 1.039\zeta + 1) = 1.4238;$$

therefore,  $T_r = 0.356$  s.

b.  $\omega_n^2 = 0.04$  r/s,  $2\zeta\omega_n = 0.02$ . Therefore  $\zeta = 0.05$ ,  $\omega_n = 0.2$ .  $T_s = \frac{4}{\zeta\omega_n} = 400$  s;  $T_P = \frac{\pi}{\omega_n\sqrt{1-\zeta^2}} =$

15.73 s; %OS =  $e^{-\zeta\pi} / \sqrt{1-\zeta^2} \times 100 = 85.45$  %;  $\omega_n T_r = (1.76\zeta^3 - 0.417\zeta^2 + 1.039\zeta + 1)$ ; therefore,

$T_r = 5.26$  s.

c.  $\omega_n^2 = 1.05 \times 10^7$  r/s,  $2\zeta\omega_n = 1.6 \times 10^3$ . Therefore  $\zeta = 0.247$ ,  $\omega_n = 3240$ .  $T_s = \frac{4}{\zeta\omega_n} = 0.005$  s;  $T_P =$

$\frac{\pi}{\omega_n\sqrt{1-\zeta^2}} = 0.001$  s; %OS =  $e^{-\zeta\pi} / \sqrt{1-\zeta^2} \times 100 = 44.92$  %;  $\omega_n T_r = (1.76\zeta^3 - 0.417\zeta^2 + 1.039\zeta +$

1); therefore,  $T_r = 3.88 \times 10^{-4}$  s.

## 21.

### Program:

```
'(a)'  
clf  
numa=16;  
dena=[1 3 16];  
Ta=tf(numa,dena)  
omegana=sqrt(dena(3))  
zetaa=dena(2)/(2*omegana)  
Tsa=4/(zetaa*omegana)  
Tpa=pi/(omegana*sqrt(1-zetaa^2))  
Tra=(1.76*zetaa^3 - 0.417*zetaa^2 + 1.039*zetaa + 1)/omegana  
percenta=exp(-zetaa*pi/sqrt(1-zetaa^2))*100  
subplot(221)  
step(Ta)  
title('(a)')  
'(b)'  
numb=0.04;  
denb=[1 0.02 0.04];  
Tb=tf(numb,denb)  
omeganb=sqrt(denb(3))  
zetab=denb(2)/(2*omeganb)  
Tsb=4/(zetab*omeganb)  
Tpb=pi/(omeganb*sqrt(1-zetab^2))  
Trb=(1.76*zetab^3 - 0.417*zetab^2 + 1.039*zetab + 1)/omeganb  
percentb=exp(-zetab*pi/sqrt(1-zetab^2))*100  
subplot(222)  
step(Tb)  
title('(b)')  
'(c)'  
numc=1.05E7;  
denc=[1 1.6E3 1.05E7];  
Tc=tf(numc,denc)  
omeganc=sqrt(denc(3))  
zetac=denc(2)/(2*omeganc)  
Tsc=4/(zetac*omeganc)  
Tpc=pi/(omeganc*sqrt(1-zetac^2))  
Trc=(1.76*zetac^3 - 0.417*zetac^2 + 1.039*zetac + 1)/omeganc  
percentc=exp(-zetac*pi/sqrt(1-zetac^2))*100  
subplot(223)  
step(Tc)  
title('(c)')
```

**Computer response:**

ans =

(a)

Transfer function:

$$\frac{16}{s^2 + 3s + 16}$$

omegana =

4

zetaa =

0.3750

Tsa =

2.6667

Tpa =

0.8472

Tra =

0.3559

percenta =

28.0597

ans =

(b)

Transfer function:

$$\frac{0.04}{s^2 + 0.02s + 0.04}$$

omeganb =

0.2000

zetaab =

0.0500

Tsb =

400

Tpb =

15.7276

Trb =

5.2556

percentb =

85.4468

ans =

(c)

Transfer function:

1.05e007

-----  
s^2 + 1600 s + 1.05e007

omeganc =

3.2404e+003

zetac =

0.2469

Tsc =

0.0050

Tpc =

0.0010

Trc =

3.8810e-004

percentc =

44.9154

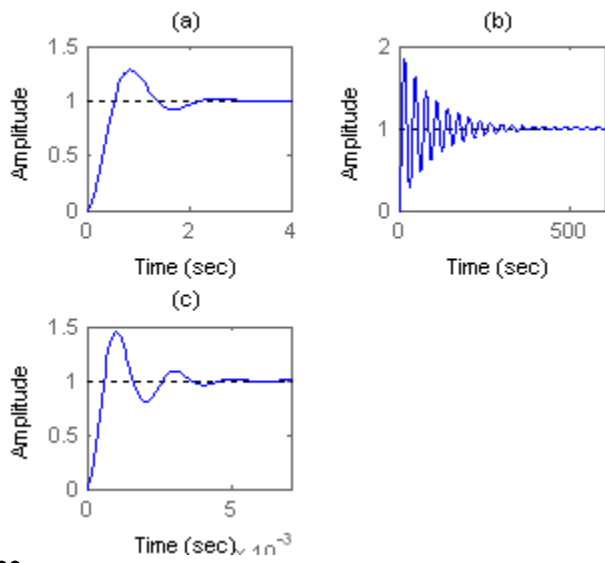

22.

**Program:**

```
T1=tf(16,[1 3 16])
T2=tf(0.04,[1 0.02 0.04])
T3=tf(1.05e7,[1 1.6e3 1.05e7])
ltiview
```

**Computer response:**

Transfer function:

```
16
-----
s^2 + 3 s + 16
```

Transfer function:

```
0.04
-----
s^2 + 0.02 s + 0.04
```

Transfer function:

```
1.05e007
-----
s^2 + 1600 s + 1.05e007
```

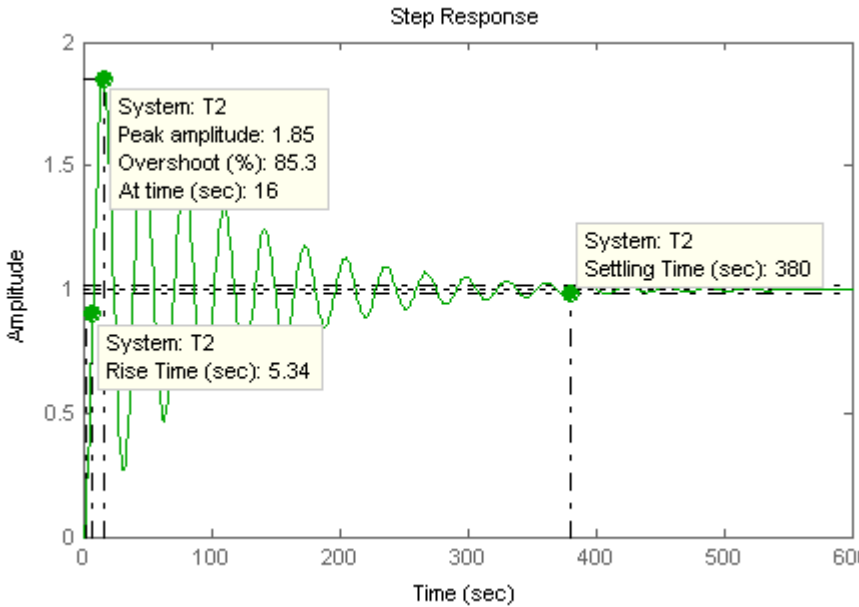
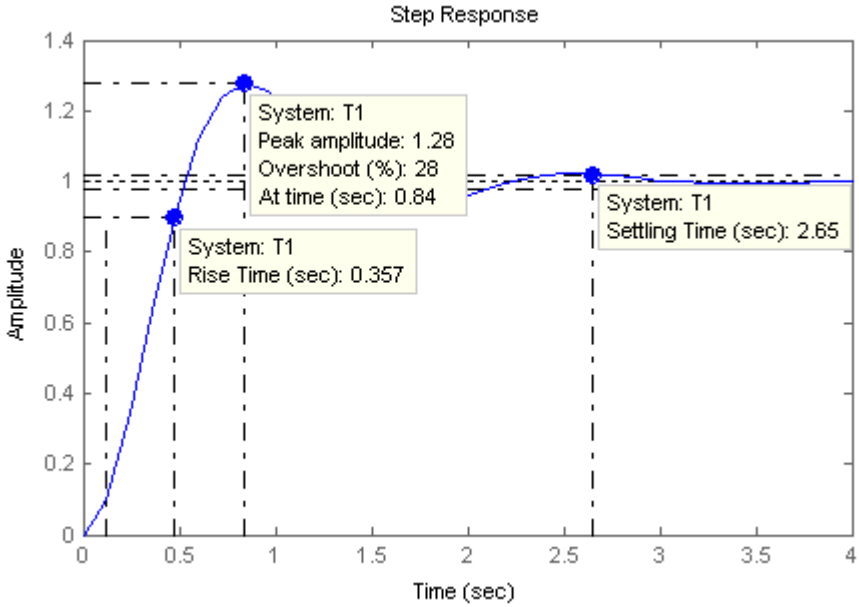

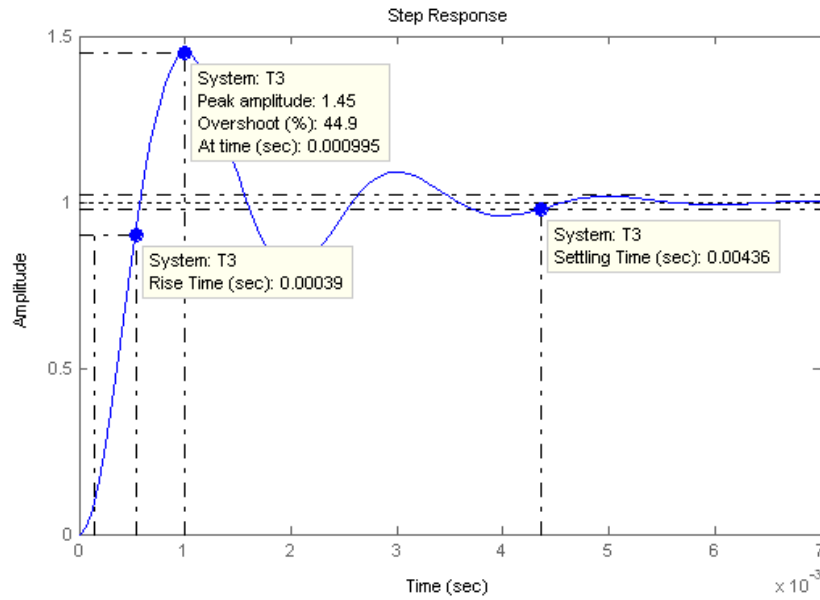

23.

$$\text{a. } \zeta = \frac{-\ln\left(\frac{\%OS}{100}\right)}{\sqrt{\pi^2 + \ln^2\left(\frac{\%OS}{100}\right)}} = 0.56, \omega_n = \frac{4}{\zeta T_s} = 11.92. \text{ Therefore, poles} = -\zeta\omega_n \pm j\omega_n\sqrt{1-\zeta^2}$$

$$= -6.67 \pm j9.88.$$

$$\text{b. } \zeta = \frac{-\ln\left(\frac{\%OS}{100}\right)}{\sqrt{\pi^2 + \ln^2\left(\frac{\%OS}{100}\right)}} = 0.591, \omega_n = \frac{\pi}{T_p\sqrt{1-\zeta^2}} = 0.779.$$

$$\text{Therefore, poles} = -\zeta\omega_n \pm j\omega_n\sqrt{1-\zeta^2} = -0.4605 \pm j0.6283.$$

$$\text{c. } \zeta\omega_n = \frac{4}{T_s} = 0.571, \omega_n\sqrt{1-\zeta^2} = \frac{\pi}{T_p} = 1.047. \text{ Therefore, poles} = -0.571 \pm j1.047.$$

24.

$$\text{Re} = \frac{4}{T_s} = 4; \zeta = \frac{-\ln(12.3/100)}{\sqrt{\pi^2 + \ln^2(12.3/100)}} = 0.5549$$

$$\text{Re} = \zeta\omega_n = 0.5549\omega_n = 4; \therefore \omega_n = 7.21$$

$$\text{Im} = \omega_n\sqrt{1-\zeta^2} = 6$$

$$\therefore G(s) = \frac{\omega_n^2}{s^2 + 2\zeta\omega_n s + \omega_n^2} = \frac{51.96}{s^2 + 8s + 51.96}$$



25.

a. Writing the equation of motion yields,  $(5s^2 + 5s + 28)X(s) = F(s)$

Solving for the transfer function,

$$\frac{X(s)}{F(s)} = \frac{1/5}{s^2 + s + \frac{28}{5}}$$

b.  $\omega_n^2 = 28/5$  r/s,  $2\zeta\omega_n = 1$ . Therefore  $\zeta = 0.211$ ,  $\omega_n = 2.37$ .  $T_s = \frac{4}{\zeta\omega_n} = 8.01$  s;  $T_p = \frac{\pi}{\omega_n\sqrt{1-\zeta^2}} =$

1.36 s; %OS =  $e^{-\zeta\pi} / \sqrt{1-\zeta^2} \times 100 = 50.7\%$ ;  $\omega_n T_r = (1.76\zeta^3 - 0.417\zeta^2 + 1.039\zeta + 1)$ ; therefore,  $T_r = 0.514$  s.

26.

Writing the loop equations,

$$(1.07s^2 + 1.53s)\theta_1(s) - 1.53\theta_2(s) = T(s)$$

$$-1.53s\theta_1(s) + (1.53s + 1.92)\theta_2(s) = 0$$

Solving for  $\theta_2(s)$ ,

$$\theta_2(s) = \frac{\begin{vmatrix} (1.07s^2 + 1.53s) & T(s) \\ -1.53s & 0 \end{vmatrix}}{\begin{vmatrix} (1.07s^2 + 1.53s) & -1.53s \\ -1.53s & (1.53s + 1.92) \end{vmatrix}} = \frac{0.935T(s)}{s^2 + 1.25s + 1.79}$$

Forming the transfer function,

$$\frac{\theta_2(s)}{T(s)} = \frac{0.935}{s^2 + 1.25s + 1.79}$$

Thus  $\omega_n = 1.34$ ,  $2\zeta\omega_n = 1.25$ . Thus,  $\zeta = 0.467$ . From Eq. (4.38), %OS = 19.0%. From Eq. (4.42),  $T_s = 6.4$  seconds. From Eq. (4.34),  $T_p = 2.66$  seconds.

27.

$$\text{a. } \frac{24.542}{s(s^2 + 4s + 24.542)} = \frac{1}{s} - \frac{s+4}{(s+2)^2 + 20.542} = \frac{1}{s} - \frac{(s+2) + \frac{2}{4.532} \cdot 4.532}{(s+2)^2 + 20.542}$$

Thus  $c(t) = 1 - e^{-2t} (\cos 4.532t + 0.441 \sin 4.532t) = 1 - 1.09e^{-2t} \cos(4.532t - 23.8^\circ)$ .

b.

$$\frac{245.42}{s(s+10)(s^2 + 4s + 24.542)} = \frac{1}{s} - 0.29029 \frac{1}{s+10} - \frac{0.70971s + 5.7418}{s^2 + 4s + 24.542}$$

$$\frac{245.42}{s(s+10)(s^2 + 4s + 24.542)} = \frac{1}{s} - 0.29029 \frac{1}{s+10} - \frac{0.70971s + 5.7418}{(s+2)^2 + 20.542}$$

$$\frac{245.42}{s(s+10)(s^2+4s+24.542)} = \frac{1}{s} - 0.29029 \frac{1}{s+10} - \frac{0.70971(s+2) + \frac{4.3223}{\sqrt{20.542}} \sqrt{20.542}}{(s+2)^2 + 20.542}$$

$$\frac{245.42}{s(s+10)(s^2+4s+24.542)} = \frac{1}{s} - 0.29029 \frac{1}{s+10} - \frac{0.70971(s+2) + 0.95367 \sqrt{20.542}}{(s+2)^2 + 20.542}$$

Therefore,  $c(t) = 1 - 0.29e^{-10t} - e^{-2t}(0.71 \cos 4.532t + 0.954 \sin 4.532t)$

$$= 1 - 0.29e^{-10t} - 1.189 \cos(4.532t - 53.34^\circ).$$

c.

$$\frac{73.626}{s(s+3)(s^2+4s+24.542)} = \frac{1}{s} - 1.1393 \frac{1}{s+3} + \frac{0.13926s - 2.8607}{s^2 + 4s + 24.542}$$

$$\frac{73.626}{s(s+3)(s^2+4s+24.542)} = \frac{1}{s} - 1.1393 \frac{1}{s+3} + \frac{0.13926(s+2) - \frac{3.1393}{\sqrt{20.542}} \sqrt{20.542}}{(s+2)^2 + 20.542}$$

$$\frac{73.626}{s(s+3)(s^2+4s+24.542)} = \frac{1}{s} - 1.1393 \frac{1}{s+3} + \frac{0.13926(s+2) - 0.69264 \sqrt{20.542}}{(s+2)^2 + 20.542}$$

Therefore,  $c(t) = 1 - 1.14e^{-3t} + e^{-2t}(0.14 \cos 4.532t - 0.69 \sin 4.532t)$

$$= 1 - 1.14e^{-3t} + 0.704 \cos(4.532t + 78.53^\circ).$$

28.

Since the third pole is more than five times the real part of the dominant pole,  $s^2+0.842s+2.829$  determines the transient response. Since  $2\zeta\omega_n = 0.842$ , and  $\omega_n = \sqrt{2.829} = \omega_n = 1.682$ ,  $\zeta = 0.25$ ,

$$\%OS = e^{-\zeta\pi/\sqrt{1-\zeta^2}} \times 100 = 44.4\%, T_s = \frac{4}{\zeta\omega_n} = 9.50 \text{ sec}, T_p = \frac{\pi}{\omega_n\sqrt{1-\zeta^2}} = 1.93 \text{ sec}; \omega_n T_r =$$

$$(1.76\zeta^3 - 0.417\zeta^2 + 1.039\zeta + 1) = 1.26, \text{ therefore, } T_r = 0.75.$$

29. a. Measuring the time constant from the graph,  $T = 0.0244$  seconds.

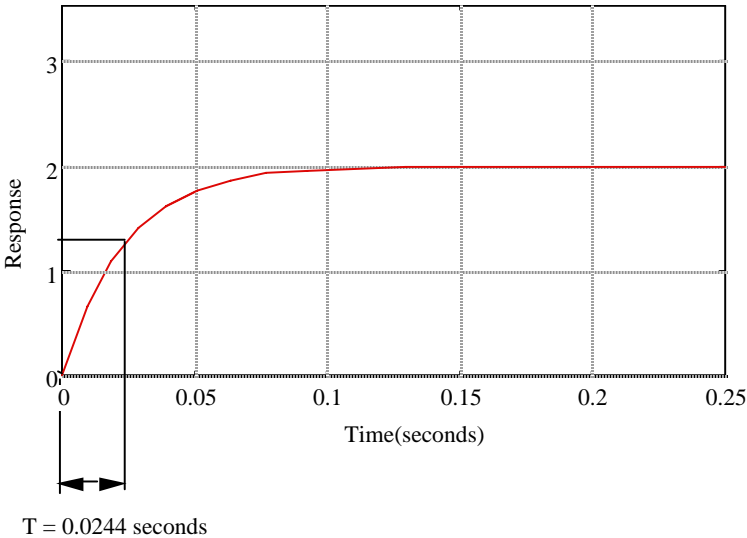

Estimating a first-order system,  $G(s) = \frac{K}{s+a}$ . But,  $a = 1/T = 40.984$ , and  $\frac{K}{a} = 2$ . Hence,  $K = 81.967$ .

Thus,

$$G(s) = \frac{81.967}{s+40.984}$$

- b. Measuring the percent overshoot and settling time from the graph:  $\%OS = (13.82-11.03)/11.03 = 25.3\%$ ,

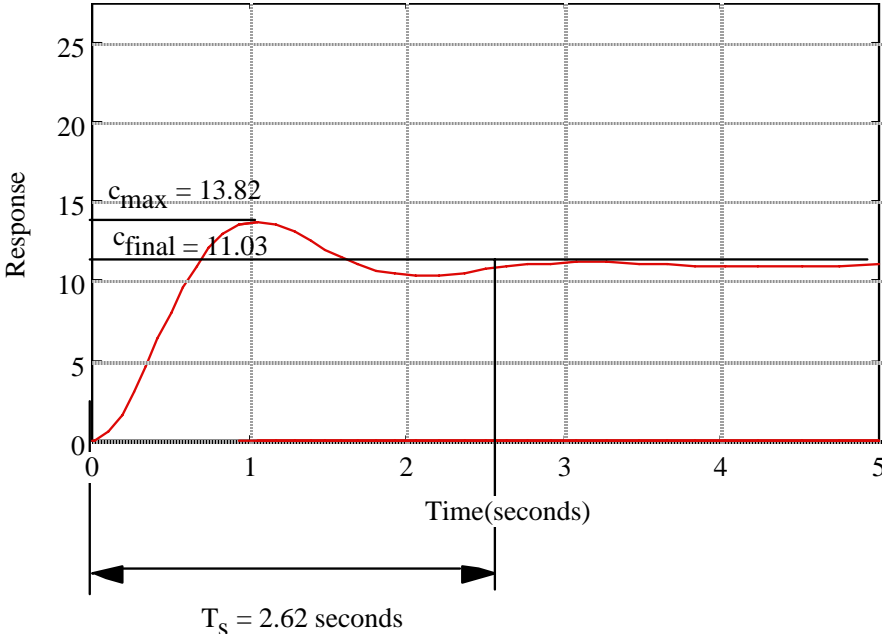

and  $T_s = 2.62$  seconds. Estimating a second-order system, we use Eq. (4.39) to find  $\zeta = 0.4$ , and Eq. (4.42) to find  $\omega_n = 3.82$ . Thus,  $G(s) = \frac{K}{s^2 + 2\zeta\omega_n s + \omega_n^2}$ . Since  $C_{\text{final}} = 11.03$ ,  $\frac{K}{\omega_n^2} = 11.03$ . Hence,

$K = 160.95$ . Substituting all values,

$$G(s) = \frac{160.95}{s^2 + 3.056s + 14.59}$$

c. From the graph, %OS = 40%. Using Eq. (4.39),  $\zeta = 0.28$ . Also from the graph,

$$T_p = \frac{\pi}{\omega_n \sqrt{1 - \zeta^2}} = 4. \text{ Substituting } \zeta = 0.28, \text{ we find } \omega_n = 0.818.$$

Thus,

$$G(s) = \frac{K}{s^2 + 2\zeta\omega_n s + \omega_n^2} = \frac{0.669}{s^2 + 0.458s + 0.669}.$$

30.

a.

$$\frac{s+3}{s(s+2)(s^2+3s+10)} = \frac{3}{20} \frac{1}{s} - \frac{1}{16} \frac{1}{s+2} - \frac{1}{80} \frac{7s+31}{\left(s+\frac{3}{2}\right)^2 + \frac{31}{4}}$$

$$\frac{s+3}{s(s+2)(s^2+3s+10)} = \frac{3}{20} \frac{1}{s} - \frac{1}{16} \frac{1}{s+2} - \frac{1}{80} \frac{7\left(s+\frac{3}{2}\right) + 7.3638\sqrt{\frac{31}{4}}}{\left(s+\frac{3}{2}\right)^2 + \frac{31}{4}}$$

Since the amplitude of the sinusoids are of the same order of magnitude as the residue of the pole at -2, pole-zero cancellation cannot be assumed.

b.

$$\frac{s+2.5}{s(s+2)(s^2+4s+20)} = \frac{1}{16} \frac{1}{s} - \frac{1}{64} \frac{1}{s+2} - \frac{1}{64} \frac{3s+14}{s^2+4s+20}$$

$$\frac{s+2.5}{s(s+2)(s^2+4s+20)} = \frac{1}{16} \frac{1}{s} - \frac{1}{64} \frac{1}{s+2} - \frac{1}{64} \frac{3(s+2) + 2\sqrt{16}}{(s+2)^2 + 16}$$

Since the amplitude of the sinusoids are of the same order of magnitude as the residue of the pole at -2, pole-zero cancellation cannot be assumed.

c.

$$\frac{s+2.1}{s(s+2)(s^2+s+5)} = 0.21 \frac{1}{s} - 0.0071429 \frac{1}{s+2} - \frac{0.20286s + 0.21714}{s^2 + 1s + 5}$$

$$\frac{s+2.1}{s(s+2)(s^2+s+5)} = 0.21 \frac{1}{s} - 0.0071429 \frac{1}{s+2} - \frac{0.20286\left(s+\frac{1}{2}\right) + 0.053093\sqrt{\frac{19}{4}}}{\left(s+\frac{1}{2}\right)^2 + \frac{19}{4}}$$

Since the amplitude of the sinusoids are of two orders of magnitude larger than the residue of the pole at -2, pole-zero cancellation can be assumed. Since  $2\zeta\omega_n = 1$ , and  $\omega_n = \sqrt{5} = 2.236$ ,  $\zeta = 0.224$ ,

$$\%OS = e^{-\zeta\pi/\sqrt{1-\zeta^2}} \times 100 = 48.64\%, T_s = \frac{4}{\zeta\omega_n} = 8 \text{ sec}, T_p = \frac{\pi}{\omega_n\sqrt{1-\zeta^2}} = 1.44 \text{ sec}; \omega_n T_r = 1.23,$$

therefore,  $T_r = 0.55$ .

d.

$$\frac{s+2.01}{s(s+2)(s^2+5s+20)} = 0.05025 \frac{1}{s} - 0.00035714 \frac{1}{s+2} - \frac{0.049893s+0.25018}{\left(s+\frac{5}{2}\right)^2 + \frac{55}{4}}$$

$$\frac{s+2.01}{s(s+2)(s^2+5s+20)} = 0.05025 \frac{1}{s} - 0.00035714 \frac{1}{s+2} - \frac{0.049893\left(s+\frac{5}{2}\right) + 0.03383\sqrt{\frac{55}{4}}}{\left(s+\frac{5}{2}\right)^2 + \frac{55}{4}}$$

Since the amplitude of the sinusoids are of two orders of magnitude larger than the residue of the pole at -2, pole-zero cancellation can be assumed. Since  $2\zeta\omega_n = 5$ , and  $\omega_n = \sqrt{20} = 4.472$ ,  $\zeta = 0.559$ ,

$$\%OS = e^{-\zeta\pi/\sqrt{1-\zeta^2}} \times 100 = 12.03\%, T_s = \frac{4}{\zeta\omega_n} = 1.6 \text{ sec}, T_p = \frac{\pi}{\omega_n\sqrt{1-\zeta^2}} = 0.847 \text{ sec}; \omega_n T_r =$$

1.852, therefore,  $T_r = 0.414$ .

31.

**Program:**

```
%Form sC(s) to get transfer function
clf
num=[1 3];
den=conv([1 3 10],[1 2]);
T=tf(num,den)
step(T)
```

**Computer response:**

Transfer function:

$$s + 3$$

-----  
 $s^3 + 5s^2 + 16s + 20$

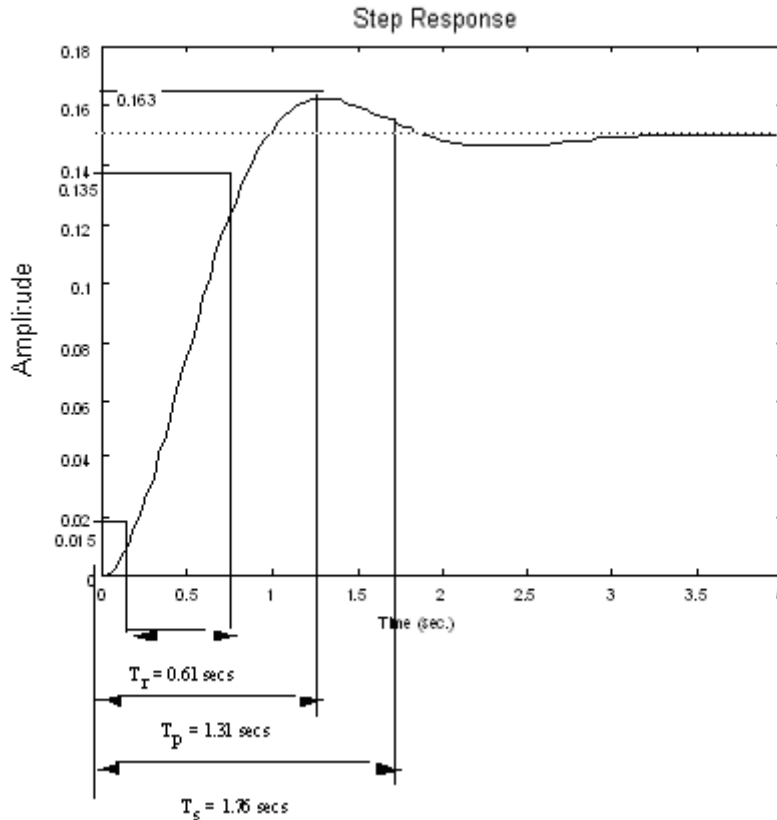

$$\%OS = \frac{(0.163 - 0.15)}{0.15} = 8.67\%$$

32.

Part c can be approximated as a second-order system. From the exponentially decaying cosine, the poles are located at  $s_{1,2} = -2 \pm j9.796$ . Thus,

$$T_s = \frac{4}{|\text{Re}|} = \frac{4}{2} = 2 \text{ s}; T_p = \frac{\pi}{|\text{Im}|} = \frac{\pi}{9.796} = 0.3207 \text{ s}$$

Also,  $\omega_n = \sqrt{2^2 + 9.796^2} = 10$  and  $\zeta\omega_n = |\text{Re}| = 2$ . Hence,  $\zeta = 0.2$ , yielding 52.66 percent overshoot.

Part d can be approximated as a second-order system. From the exponentially decaying cosine, the poles are located at  $s_{1,2} = -2 \pm j9.951$ . Thus,

$$T_s = \frac{4}{|\text{Re}|} = \frac{4}{2} = 2 \text{ s}; T_p = \frac{\pi}{|\text{Im}|} = \frac{\pi}{9.951} = 0.3157 \text{ s}$$

Also,  $\omega_n = \sqrt{2^2 + 9.951^2} = 10.15$  and  $\zeta\omega_n = |\text{Re}| = 2$ . Hence,  $\zeta = 0.197$ , yielding 53.19 percent overshoot.

33.

a.

$$(1) \quad C_{a1}(s) = \frac{1}{s^2 + 3s + 36} = \frac{\frac{1}{\sqrt{33.75}} \sqrt{33.75}}{(s + 1.5)^2 + 33.75} = \frac{0.17213 \sqrt{33.75}}{(s + 1.5)^2 + 33.75} = \frac{0.17213 \cdot 5.8095}{(s + 1.5)^2 + 33.75}$$

Taking the inverse Laplace transform

$$C_{a1}(t) = 0.17213 e^{-1.5t} \sin 5.8095t$$

$$(2) \quad C_{a2}(s) = \frac{2}{s(s^2 + 3s + 36)} = \frac{1}{18} \frac{1}{s} - \frac{\frac{1}{18}s + \frac{1}{6}}{s^2 + 3s + 36} =$$

$$\frac{1}{18} \frac{1}{s} - \frac{\frac{1}{18} \left( s + \frac{3}{2} \right) + \frac{0.083333}{\sqrt{33.75}}}{\left( s + \frac{3}{2} \right)^2 + 33.75}$$

$$= 0.055556 \frac{1}{s} - \frac{0.055556 \left( s + \frac{3}{2} \right) + 0.014344 \sqrt{33.75}}{\left( s + \frac{3}{2} \right)^2 + 33.75}$$

Taking the inverse Laplace transform

$$C_{a2}(t) = 0.055556 - e^{-1.5t} (0.055556 \cos 5.809t + 0.014344 \sin 5.809t)$$

The total response is found as follows:

$$C_{at}(t) = C_{a1}(t) + C_{a2}(t) = 0.055556 - e^{-1.5t} (0.055556 \cos 5.809t - 0.157786 \sin 5.809t)$$

Plotting the total response:

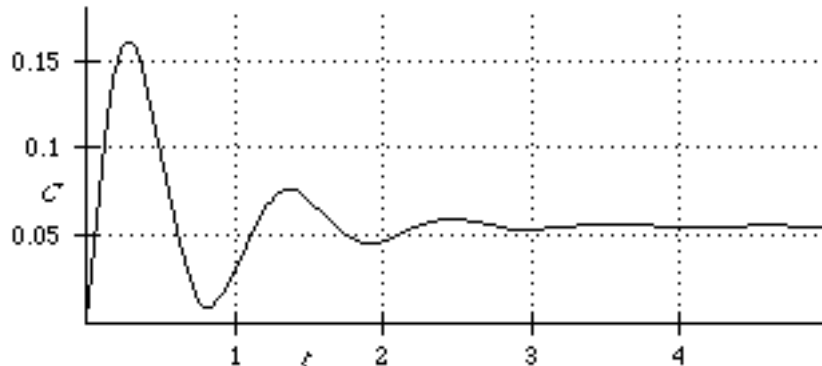

**b.**

(1) Same as (1) from part (a), or  $C_{b1}(t) = C_{a1}(t)$

(2) Same as the negative of (2) of part (a), or  $C_{b2}(t) = -C_{a2}(t)$

The total response is

$$C_{bt}(t) = C_{b1}(t) + C_{b2}(t) = C_{a1}(t) - C_{a2}(t) = -0.055556 + e^{-1.5t} (0.055556 \cos 5.809t + 0.186474 \sin 5.809t)$$

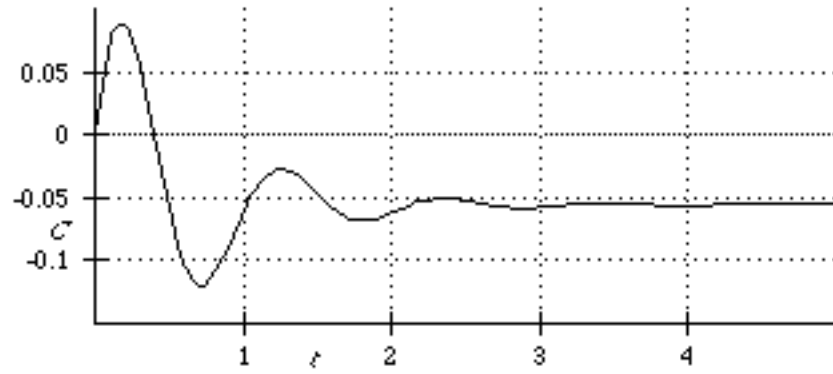

Notice the nonminimum phase behavior for  $C_{bt}(t)$ .



34.

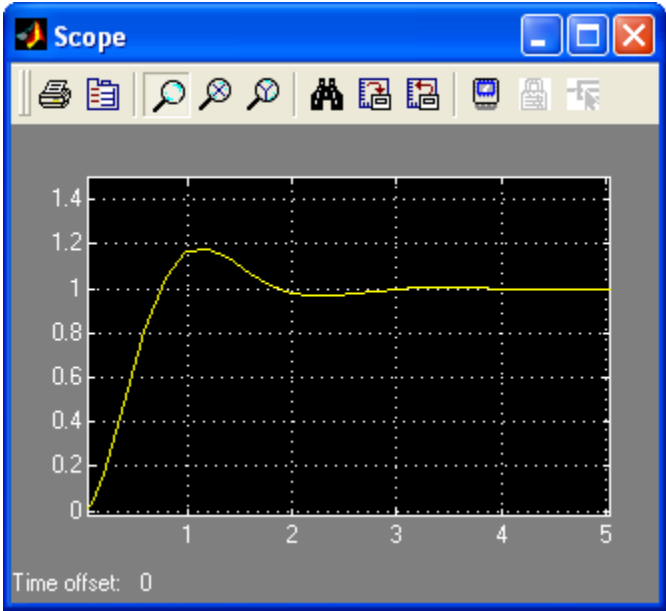
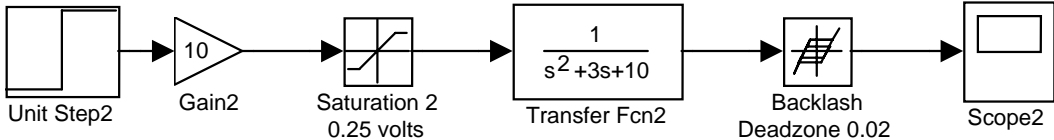
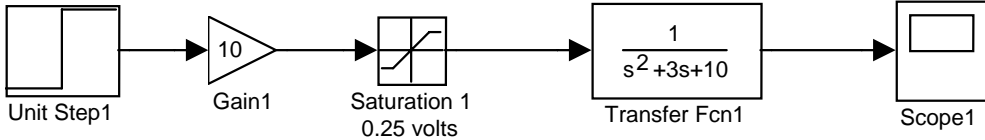
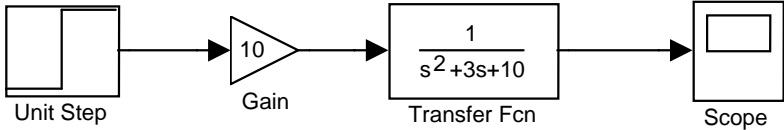

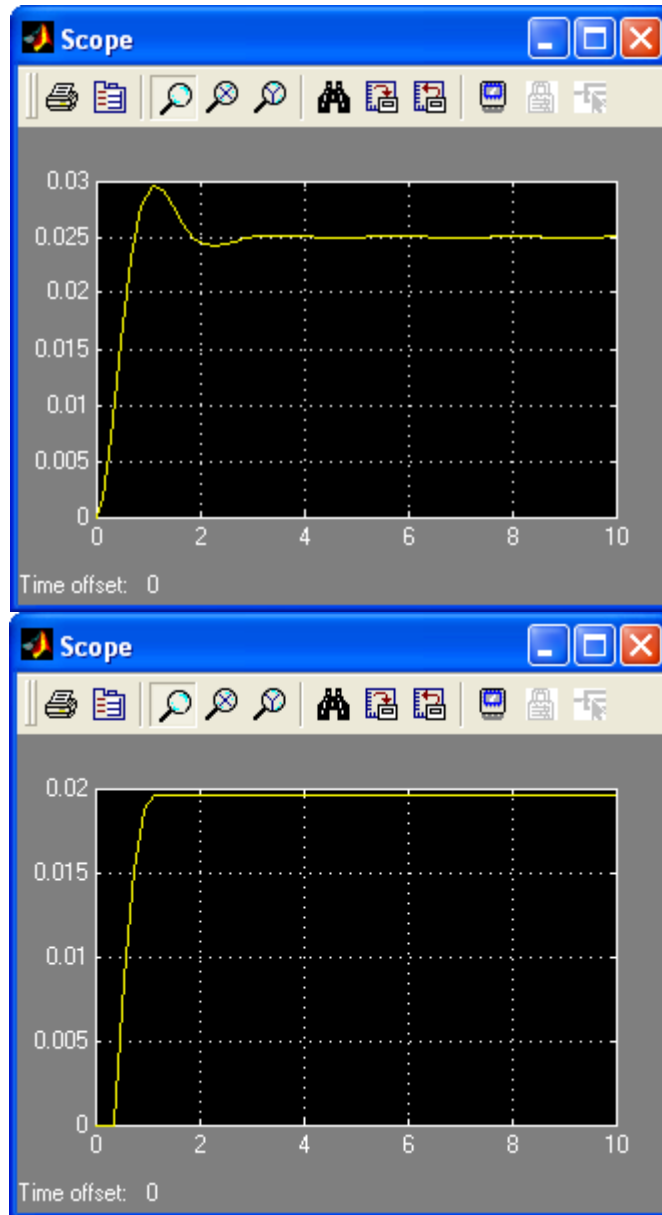

35.

$$s\mathbf{I} - \mathbf{A} = s \begin{bmatrix} 1 & 0 \\ 0 & 1 \end{bmatrix} - \begin{bmatrix} -2 & -1 \\ -3 & -5 \end{bmatrix} = \begin{bmatrix} (s+2) & 1 \\ 3 & (s+5) \end{bmatrix}$$

$$|s\mathbf{I} - \mathbf{A}| = s^2 + 7s + 7$$

Factoring yields poles at  $-5.7913$  and  $-1.2087$ .

36.

a.

$$s\mathbf{I} - \mathbf{A} = s \left[ \begin{array}{ccc|ccc} 1 & 0 & 0 & 0 & 2 & 3 \\ 0 & 1 & 0 & 0 & 6 & 5 \\ 0 & 0 & 1 & 1 & 4 & 2 \end{array} \right] = \left[ \begin{array}{ccc|ccc} s & -2 & -3 & & & \\ 0 & (s-6) & -5 & & & \\ -1 & -4 & (s-2) & & & \end{array} \right]$$

$$|s\mathbf{I} - \mathbf{A}| = s^3 - 8s^2 - 11s + 8$$

b. Factoring yields poles at 9.111, 0.5338, and -1.6448.

37.

$$\mathbf{x} = (s\mathbf{I} - \mathbf{A})^{-1} (\mathbf{x}_0 + \mathbf{B}u)$$

$$\mathbf{X} = \left( s \left[ \begin{array}{cc} 1 & 0 \\ 0 & 1 \end{array} \right] - \left[ \begin{array}{cc} 1 & 2 \\ -3 & -1 \end{array} \right] \right)^{-1} \left( \left[ \begin{array}{c} 3 \\ 1 \end{array} \right] + \left[ \begin{array}{c} 1 \\ 1 \end{array} \right] \cdot 3 \frac{1}{s^2 + 9} \right)$$

$$\mathbf{X} = \begin{pmatrix} \frac{3s^3 + 5s^2 + 30s + 54}{[s^2 + 5][s^2 + 9]} \\ \frac{s^3 - 10s^2 + 12s - 102}{[s^2 + 5][s^2 + 9]} \end{pmatrix}$$

$$Y(s) = [1 \quad 2]\mathbf{X}$$

$$Y(s) = \left( \frac{5s^3 - 15s^2 + 54s - 150}{[s^2 + 9][s^2 + 5]} \right)$$

38.

$$\mathbf{x} = (s\mathbf{I} - \mathbf{A})^{-1} (\mathbf{x}_0 + \mathbf{B}u)$$

$$\mathbf{x} = \left( s \left[ \begin{array}{ccc} 1 & 0 & 0 \\ 0 & 1 & 0 \\ 0 & 0 & 1 \end{array} \right] - \left[ \begin{array}{ccc} 0 & 1 & 0 \\ -2 & -4 & 1 \\ 0 & 0 & -6 \end{array} \right] \right)^{-1} \left( \left[ \begin{array}{c} 0 \\ 0 \\ 0 \end{array} \right] + \left[ \begin{array}{c} 0 \\ 0 \\ 1 \end{array} \right] \frac{1}{s+1} \right)$$

$$\mathbf{x} = \begin{pmatrix} \frac{1}{[s+6][s+1][s+0.58579][s+3.4142]} \\ \frac{s}{[s+6][s+1][s+0.58579][s+3.4142]} \\ \frac{s^2 + 4s + 2}{[s+6][s+1][s+0.58579][s+3.4142]} \end{pmatrix}$$

$$Y(s) = [0 \quad 0 \quad 1]\mathbf{X}$$

$$Y(s) = \frac{s^2 + 4s + 2}{[s+6][s+1][s+0.58579][s+3.4142]}$$

39.

$$\mathbf{x} = (s\mathbf{I} - \mathbf{A})^{-1}(\mathbf{x}_0 + \mathbf{B}u)$$

$$\mathbf{X} = \left( s \begin{bmatrix} 1 & 0 \\ 0 & 1 \end{bmatrix} - \begin{bmatrix} -2 & 0 \\ -1 & -1 \end{bmatrix} \right)^{-1} \left( \begin{bmatrix} 3 \\ 0 \end{bmatrix} + \begin{bmatrix} 1 \\ 1 \end{bmatrix} \frac{1}{s} \right)$$

$$\mathbf{X} = \begin{pmatrix} \frac{3s+1}{s[s+2]} \\ \frac{1-2s}{s[s+1][s+2]} \end{pmatrix}$$

$$Y(s) = [0 \quad 1]\mathbf{X}$$

$$Y(s) = \left( \frac{1-2s}{s[s+1][s+2]} \right)$$

Applying partial fraction decomposition,

$$Y(s) = \left( \frac{1}{2} \frac{1}{s} - \frac{3}{s+1} + \frac{5}{2} \frac{1}{s+2} \right)$$

$$y(t) = \frac{1}{2}u(t) - 3e^{-t} + \frac{5}{2}e^{-2t}$$

40.

$$\mathbf{x} = (s\mathbf{I} - \mathbf{A})^{-1}(\mathbf{x}_0 + \mathbf{B}u)$$

$$\mathbf{x} = \left( \begin{array}{ccc|ccc} [1 & 0 & 0] & [-3 & 1 & 0] \\ s & 0 & 1 & 0 & -6 & 1 \\ [0 & 0 & 1] & [0 & 0 & -5] \end{array} \right)^{-1} \left( \begin{array}{c} [0] \\ [0] \\ [0] \end{array} + \begin{array}{c} [0] \\ [1] \\ [1] \end{array} \frac{1}{s} \right)$$

$$\mathbf{x} = \begin{bmatrix} \frac{1}{s(s+3)(s+5)} \\ \frac{1}{s(s+5)} \\ \frac{1}{s(s+5)} \end{bmatrix}$$

$$\mathbf{x}(t) = \begin{bmatrix} \frac{1}{15} - \frac{1}{6}e^{-3t} + \frac{1}{10}e^{-5t} \\ \frac{1}{5} - \frac{1}{5}e^{-5t} \\ \frac{1}{5} - \frac{1}{5}e^{-5t} \end{bmatrix}$$

$$y(t) = [0 \quad 1 \quad 1]\mathbf{x} = \frac{2}{5} - \frac{2}{5}e^{-5t}$$

41.

**Program:**

```
A=[-3 1 0;0 -6 1;0 0 -5];
B=[0;1;1];
C=[0 1 1];
D=0;
S=ss(A,B,C,D)
step(S)
```

**Computer response:**

```
a =
      x1  x2  x3
x1    -3   1   0
x2     0  -6   1
x3     0   0  -5
```

```
b =
      u1
x1     0
x2     1
x3     1
```

```
c =
      x1  x2  x3
y1     0   1   1
```

```
d =
      u1
y1     0
```

Continuous-time model.

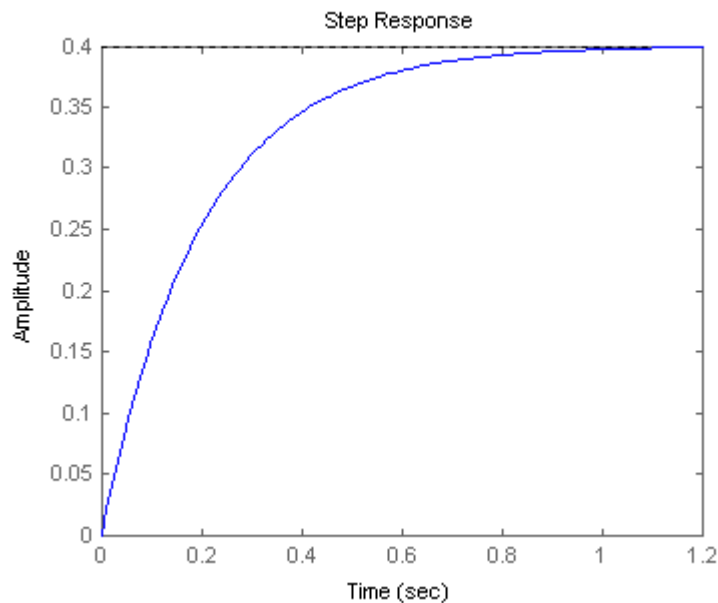

42.

**Program:**

```

syms s %Construct symbolic object for
        %frequency variable 's'.
'a' %Display label
A=[-3 1 0;0 -6 1;0 0 -5] %Create matrix A.
B=[0;1;1]; %Create vector B.
C=[0 1 1]; %Create C vector
X0=[1;1;0] %Create initial condition vector,X(0).
U=1/s; %Create U(s).
I=[1 0 0;0 1 0;0 0 1]; %Create identity matrix.
X=((s*I-A)^-1)*(X0+B*U); %Find Laplace transform of state vector.
x1=ilaplace(X(1)) %Solve for X1(t).
x2=ilaplace(X(2)) %Solve for X2(t).
x3=ilaplace(X(3)) %Solve for X3(t).
y=C*[x1;x2;x3] %Solve for output, y(t).
y=simplify(y) %Simplify y(t).
'y(t)' %Display label.
pretty(y) %Pretty print y(t).

```

**Computer response:**

```

ans =

a

A =

    -3     1     0
     0    -6     1
     0     0    -5

X0 =

     1
     1
     0

x1 =

7/6*exp(-3*t)-1/3*exp(-6*t)+1/15+1/10*exp(-5*t)

x2 =

exp(-6*t)+1/5-1/5*exp(-5*t)

x3 =

1/5-1/5*exp(-5*t)

y =

2/5+exp(-6*t)-2/5*exp(-5*t)

y =

2/5+exp(-6*t)-2/5*exp(-5*t)

ans =

y(t)

2/5 + exp(-6 t) - 2/5 exp(-5 t)

```

43.

$$|\lambda \mathbf{I} - \mathbf{A}| = \lambda^2 + 5\lambda + 1$$

$$|\lambda \mathbf{I} - \mathbf{A}| = (\lambda + 0.20871)(\lambda + 4.7913)$$

$$\mathbf{P} = -0.20871$$

$$\begin{aligned} Q &= -4.7913 \\ \Phi &= \begin{pmatrix} A_1 e^{-0.20871t} + A_2 e^{-4.7913t} & A_5 e^{-0.20871t} + A_6 e^{-4.7913t} \\ A_3 e^{-0.20871t} + A_4 e^{-4.7913t} & A_7 e^{-0.20871t} + A_8 e^{-4.7913t} \end{pmatrix} \\ \Phi_0 &= \begin{pmatrix} A_2 + A_1 & A_6 + A_5 \\ A_4 + A_3 & A_8 + A_7 \end{pmatrix} \end{aligned}$$

$$\frac{\partial}{\partial t} \Phi = \begin{pmatrix} -0.20871 A_1 e^{-0.20871t} - 4.7913 A_2 e^{-4.7913t} & -0.20871 A_5 e^{-0.20871t} - 4.7913 A_6 e^{-4.7913t} \\ -0.20871 A_3 e^{-0.20871t} - 4.7913 A_4 e^{-4.7913t} & -0.20871 A_7 e^{-0.20871t} - 4.7913 A_8 e^{-4.7913t} \end{pmatrix}$$

$$\frac{d}{dt} \Phi_0 = \begin{pmatrix} -4.7913 A_2 - 0.20871 A_1 & -4.7913 A_6 - 0.20871 A_5 \\ -4.7913 A_4 - 0.20871 A_3 & -4.7913 A_8 - 0.20871 A_7 \end{pmatrix}$$

Therefore,

$$\begin{aligned} \begin{pmatrix} A_2 + A_1 & A_6 + A_5 \\ A_4 + A_3 & A_8 + A_7 \end{pmatrix} &= \begin{pmatrix} 1 & 0 \\ 0 & 1 \end{pmatrix} \\ \begin{pmatrix} -4.7913 A_2 - 0.20871 A_1 & -4.7913 A_6 - 0.20871 A_5 \\ -4.7913 A_4 - 0.20871 A_3 & -4.7913 A_8 - 0.20871 A_7 \end{pmatrix} &= \begin{pmatrix} 0 & 1 \\ -1 & -5 \end{pmatrix} \end{aligned}$$

Solving for  $A_i$ 's two at a time, and substituting into the state-transition matrix

$$\Phi = \begin{pmatrix} 1.0455 e^{-0.20871t} - 0.045545 e^{-4.7913t} & 0.21822 e^{-0.20871t} - 0.21822 e^{-4.7913t} \\ -0.21822 e^{-0.20871t} + 0.21822 e^{-4.7913t} & -0.045545 e^{-0.20871t} + 1.0455 e^{-4.7913t} \end{pmatrix}$$

To find  $x(t)$ ,

$$\begin{aligned} x &= \Phi x_0 \\ x &= \begin{pmatrix} 1.0455 e^{-0.20871t} - 0.045545 e^{-4.7913t} & 0.21822 e^{-0.20871t} - 0.21822 e^{-4.7913t} \\ -0.21822 e^{-0.20871t} + 0.21822 e^{-4.7913t} & -0.045545 e^{-0.20871t} + 1.0455 e^{-4.7913t} \end{pmatrix} \begin{pmatrix} 1 \\ 0 \end{pmatrix} \\ x &= \begin{pmatrix} 1.0455 e^{-0.20871t} - 0.045545 e^{-4.7913t} \\ -0.21822 e^{-0.20871t} + 0.21822 e^{-4.7913t} \end{pmatrix} \end{aligned}$$

To find the output,

$$\begin{aligned} y &= (1, 2)x \\ y &= (1, 2) \begin{pmatrix} 1.0455 e^{-0.20871t} - 0.045545 e^{-4.7913t} \\ -0.21822 e^{-0.20871t} + 0.21822 e^{-4.7913t} \end{pmatrix} \\ y &= (0.60911 e^{-0.20871t} + 0.39089 e^{-4.7913t}) \end{aligned}$$

44.

$$\lambda I - A = \begin{pmatrix} \lambda & -1 \\ 1 & \lambda \end{pmatrix}$$

$$|\lambda I - A| = \lambda^2 + 1$$

$$\Phi = \begin{pmatrix} A_1 \cos[t] + A_2 \sin[t] & A_5 \cos[t] + A_6 \sin[t] \\ A_3 \cos[t] + A_4 \sin[t] & A_7 \cos[t] + A_8 \sin[t] \end{pmatrix}$$

$$\begin{aligned}\frac{d}{dt}\phi &= \begin{pmatrix} A_2 \cos[t] - A_1 \sin[t] & A_6 \cos[t] - A_5 \sin[t] \\ A_4 \cos[t] - A_3 \sin[t] & A_8 \cos[t] - A_7 \sin[t] \end{pmatrix} \\ \phi_0 &= \begin{pmatrix} A_1 & A_5 \\ A_3 & A_7 \end{pmatrix} \\ \frac{d}{dt}\phi_0 &= \begin{pmatrix} A_2 & A_6 \\ A_4 & A_8 \end{pmatrix} \\ \begin{pmatrix} A_1 & A_5 \\ A_3 & A_7 \end{pmatrix} &= \begin{pmatrix} 1 & 0 \\ 0 & 1 \end{pmatrix} \\ \begin{pmatrix} A_2 & A_6 \\ A_4 & A_8 \end{pmatrix} &= \begin{pmatrix} 0 & 1 \\ -1 & 0 \end{pmatrix}\end{aligned}$$

Solving for the  $A_i$ 's and substituting into the state-transition matrix,

$$\phi = \begin{pmatrix} \cos[t] & \sin[t] \\ -\sin[t] & \cos[t] \end{pmatrix}$$

To find the state vector,

$$\begin{aligned}x &= \int_0^t (\phi[t-\tau] B u[\tau]) d\tau \\ x &= \int_0^t \left( \begin{bmatrix} \cos(t-\tau) & \sin(t-\tau) \\ -\sin(t-\tau) & \cos(t-\tau) \end{bmatrix} \begin{bmatrix} 0 \\ 1 \end{bmatrix} \right) d\tau \\ x &= \int_0^t \begin{pmatrix} \sin[t-\tau] \\ \cos[t-\tau] \end{pmatrix} d\tau\end{aligned}$$

$$\begin{aligned}t-\tau &= \theta \\ x &= \int_t^0 \begin{pmatrix} -\sin[\theta] \\ -\cos[\theta] \end{pmatrix} d\theta\end{aligned}$$

$$x = \begin{pmatrix} 1 - \cos[t] \\ \sin[t] \end{pmatrix}$$

$$y = (3, 4)x$$

$$\Delta y = (3, 4) \begin{pmatrix} 1 - \cos[t] \\ \sin[t] \end{pmatrix}$$

$$y = (-3 \cos[t] + 4 \sin[t] + 3)$$

45.

$$|\lambda \mathbf{I} - \mathbf{A}| = (\lambda + 2)(\lambda + 0.5 - 2.3979i)(\lambda + 0.5 + 2.3979i)$$

Let the state-transition matrix be

$$\phi = \begin{bmatrix} A_1 e^{-.5t} \cos(2.3979t) + A_2 e^{-.5t} \sin(2.3979t) + A_3 e^{-2t} & A_{10} e^{-.5t} \cos(2.3979t) + A_{11} e^{-.5t} \sin(2.3979t) + A_{12} & \bullet \\ A_4 e^{-.5t} \cos(2.3979t) + A_5 e^{-.5t} \sin(2.3979t) + A_6 e^{-2t} & A_{13} e^{-.5t} \cos(2.3979t) + A_{14} e^{-.5t} \sin(2.3979t) + A_{15} & \bullet \\ A_7 e^{-.5t} \cos(2.3979t) + A_8 e^{-.5t} \sin(2.3979t) + A_9 e^{-2t} & A_{16} e^{-.5t} \cos(2.3979t) + A_{17} e^{-.5t} \sin(2.3979t) + A_{18} & \bullet \end{bmatrix}$$



Since  $\phi(0) = \mathbf{I}$ ,  $\dot{\phi}(0) = \mathbf{A}$ , and  $\ddot{\phi}(0) = \mathbf{A}^2$ , we can evaluate the coefficients,  $A_i$ 's. Thus,

$$\begin{pmatrix} A_3 + A_1 & A_{12} + A_{10} & A_{21} + A_{19} \\ A_6 + A_4 & A_{15} + A_{13} & A_{24} + A_{22} \\ A_9 + A_7 & A_{18} + A_{16} & A_{27} + A_{25} \end{pmatrix} = \begin{pmatrix} 1 & 0 & 0 \\ 0 & 1 & 0 \\ 0 & 0 & 1 \end{pmatrix}$$

$$\begin{pmatrix} -2A_3 + 2.3979A_2 - 0.5A_1 & -2A_{12} + 2.3979A_{11} - 0.5A_{10} & -2A_{21} + 2.3979A_{20} - 0.5A_{19} \\ -2A_6 + 2.3979A_5 - 0.5A_4 & -2A_{15} + 2.3979A_{14} - 0.5A_{13} & -2A_{24} + 2.3979A_{23} - 0.5A_{22} \\ -2A_9 + 2.3979A_8 - 0.5A_7 & -2A_{18} + 2.3979A_{17} - 0.5A_{16} & -2A_{27} + 2.3979A_{26} - 0.5A_{25} \end{pmatrix} = \begin{pmatrix} -2 & 1 & 0 \\ 0 & 0 & 1 \\ 0 & -6 & -1 \end{pmatrix}$$

$$\begin{pmatrix} 4A_3 - 2.3979A_2 - 5.4999A_1 & 4A_{12} - 2.3979A_{11} - 5.4999A_{10} & 4A_{21} - 2.3979A_{20} - 5.4999A_{19} \\ 4A_6 - 2.3979A_5 - 5.4999A_4 & 4A_{15} - 2.3979A_{14} - 5.4999A_{13} & 4A_{24} - 2.3979A_{23} - 5.4999A_{22} \\ 4A_9 - 2.3979A_8 - 5.4999A_7 & 4A_{18} - 2.3979A_{17} - 5.4999A_{16} & 4A_{27} - 2.3979A_{26} - 5.4999A_{25} \end{pmatrix} = \begin{pmatrix} 4 & -2 & 1 \\ 0 & -6 & -1 \\ 0 & 6 & -5 \end{pmatrix}$$

Solving for the  $A_i$ 's taking three equations at a time,

$$\phi = \begin{pmatrix} e^{-2t} & 0.125e^{-0.5t}\cos[2.3979t] + 0.33884e^{-0.5t}\sin[2.3979t] - 0.125e^{-2t} & \\ 0 & e^{-0.5t}\cos[2.3979t] + 0.20851e^{-0.5t}\sin[2.3979t] & \\ 0 & -2.502e^{-0.5t}\sin[2.3979t] & \\ & -0.125e^{-0.5t}\cos[2.3979t] + 0.078194e^{-0.5t}\sin[2.3979t] + 0.125e^{-2t} & \\ & 0.41703e^{-0.5t}\sin[2.3979t] & \\ & e^{-0.5t}\cos[2.3979t] - 0.20852e^{-0.5t}\sin[2.3979t] & \end{pmatrix}$$

Using  $\mathbf{x}(t) = \phi(t)\mathbf{x}(0) + \int_0^t \phi(t-\tau)\mathbf{B}\mathbf{u}(\tau)d\tau$ , and  $\mathbf{y} = \begin{bmatrix} 1 & 0 & 0 \end{bmatrix}\mathbf{x}(t)$ ,

$$\begin{aligned} \mathbf{y} &= \int_0^t e^{-2(t-\tau)} d\tau \\ &= \frac{1}{2} - \frac{1}{2} e^{-2t} \end{aligned}$$

46.

**Program:**

```
syms s t tau                                %Construct symbolic object for
                                              %frequency variable 's', 't', and 'tau.'
                                              %Display label.
'a'
A=[-2 1 0;0 0 1;0 -6 -1]                    %Create matrix A.
B=[1;0;0]                                    %Create vector B.
C=[1 0 0]                                    %Create vector C.
X0=[1;1;0]                                   %Create initial condition vector,X(0).
I=[1 0 0;0 1 0;0 0 1];                     %Create identity matrix.
'E=(s*I-A)^-1'                               %Display label.
E=((s*I-A)^-1)                               %Find Laplace transform of state
                                              %transition matrix, (sI-A)^-1.
Fi1=ilaplace(E(1,1));                        %Take inverse Laplace transform
Fi12=ilaplace(E(1,2));                       %of each element
Fi13=ilaplace(E(1,3));
Fi21=ilaplace(E(2,1));
Fi22=ilaplace(E(2,2));
Fi23=ilaplace(E(2,3));
```

```

Fi31=ilaplace(E(3,1));
Fi32=ilaplace(E(3,2)); %to find state transition matrix.
Fi33=ilaplace(E(3,3)); %of (sI-A)^-1.
'Fi(t)' %Display label.
Fi=[Fi11 Fi12 Fi13 %Form Fi(t).
Fi21 Fi22 Fi23
Fi31 Fi32 Fi33];
pretty(Fi) %Pretty print state transition matrix, Fi.
Fitmtau=subs(Fi,t,t-tau); %Form Fi(t-tau).
'Fi(t-tau)' %Display label.
pretty(Fitmtau) %Pretty print Fi(t-tau).
x=Fi*X0+int(Fitmtau*B*1,tau,0,t); %Solve for x(t).
x=simple(x); %Collect terms.
x=simplify(x); %Simplify x(t).
x=vpa(x,3);
'x(t)' %Display label.
pretty(x) %Pretty print x(t).
y=C*x; %Find y(t)
y=simplify(y);
y=vpa(simple(y),3);
y=collect(y);
'y(t)'
pretty(y) %Pretty print y(t).

```

**Computer response:**

ans =

a

A =

$$\begin{bmatrix} -2 & 1 & 0 \\ 0 & 0 & 1 \\ 0 & -6 & -1 \end{bmatrix}$$

B =

$$\begin{bmatrix} 1 \\ 0 \\ 0 \end{bmatrix}$$

C =

$$\begin{bmatrix} 1 & 0 & 0 \end{bmatrix}$$

X0 =

$$\begin{bmatrix} 1 \\ 1 \\ 0 \end{bmatrix}$$

ans =

E=(s\*I-A)^-1

E =

$$\begin{bmatrix} 1/(s+2), & (s+1)/(s+2)/(s^2+s+6), & 1/(s+2)/(s^2+s+6) \\ 0, & (s+1)/(s^2+s+6), & 1/(s^2+s+6) \\ 0, & -6/(s^2+s+6), & s/(s^2+s+6) \end{bmatrix}$$

ans =

Fi(t)

```

[
[exp(-2 t) , - 1/8 exp(-2 t) + 1/8 %1 + --- %2 ,
[
184
]
]
1/8 exp(-2 t) - 1/8 %1 + 3/184 %2]
]

[
[0 , 1/23 %2 + %1 , - 1/23
( -23 )1/2 (exp((-1/2 + 1/2 (-23)1/2 ) t) - exp((-1/2 - 1/2 (-23)1/2 ) t))
]
]

[
[0 , 6/23
( -23 )1/2 (exp((-1/2 + 1/2 (-23)1/2 ) t) - exp((-1/2 - 1/2 (-23)1/2 ) t))
, - 1/23 %2 + %1]
]

%1 := exp(- 1/2 t) cos(1/2 231/2 t)
%2 := exp(- 1/2 t) 231/2 sin(1/2 231/2 t)

```

ans =

Fi(t-tau)

```

[
[exp(-2 t + 2 tau) ,
[
- 1/8 exp(-2 t + 2 tau) + 1/8 %2 cos(%1) + --- %2 231/2 sin(%1) ,
184
]
]
1/8 exp(-2 t + 2 tau) - 1/8 %2 cos(%1) + 3/184 %2 231/2 sin(%1)]
]

[
[0 , 1/23 %2 231/2 sin(%1) + %2 cos(%1) , - 1/23 (-23)1/2 (
exp((-1/2 + 1/2 (-23)1/2 ) (t - tau))
- exp((-1/2 - 1/2 (-23)1/2 ) (t - tau))]
]
]

[
[0 , 6/23 (-23)1/2 (exp((-1/2 + 1/2 (-23)1/2 ) (t - tau))
- exp((-1/2 - 1/2 (-23)1/2 ) (t - tau)) ,

```

4-44 Chapter 4: Time Response

```

- 1/23 %2 23      1/2      ]
sin(%1) + %2 cos(%1)]

%1 := 1/2 23      1/2      (t - tau)

%2 := exp(- 1/2 t + 1/2 tau)

ans =

x(t)

[.375 exp(-2. t) + .125 exp(-.500 t) cos(2.40 t)
+ .339 exp(-.500 t) sin(2.40 t) + .500]

[.209 exp(-.500 t) sin(2.40 t) + exp(-.500 t) cos(2.40 t)]

[1.25 i (exp((- .500 + 2.40 i) t) - 1. exp((- .500 - 2.40 i) t))]

ans =

y(t)

.375 exp(-2. t) + .125 exp(-.500 t) cos(2.40 t)
+ .339 exp(-.500 t) sin(2.40 t) + .500

```

47. The state-space representation used to obtain the plot is,

$$\dot{\mathbf{x}} = \begin{bmatrix} 0 & 1 \\ -1 & -0.8 \end{bmatrix} \mathbf{x} + \begin{bmatrix} 0 \\ 1 \end{bmatrix} u(t); \quad y(t) = \begin{bmatrix} 1 & 0 \end{bmatrix} \mathbf{x}$$

Using the Step Response software,

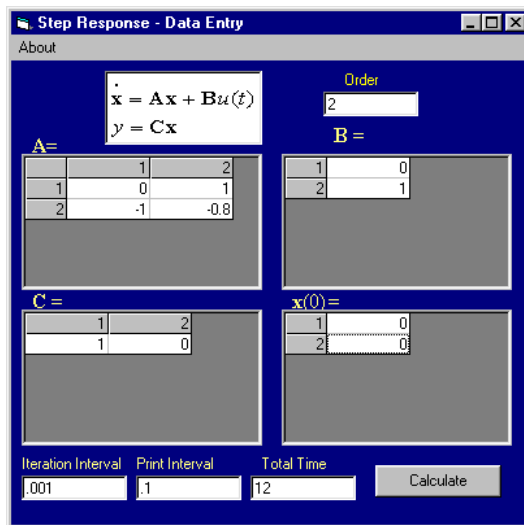

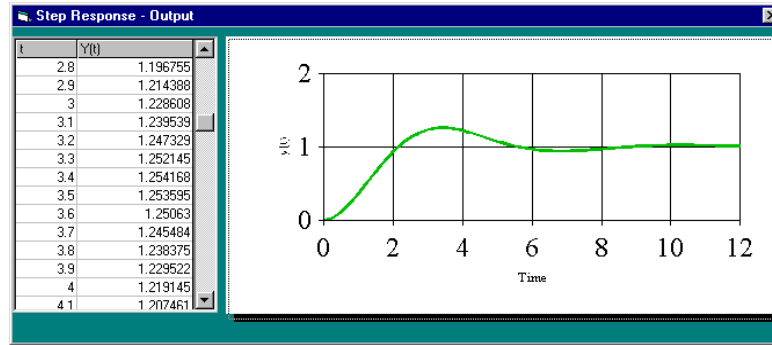

Calculating % overshoot, settling time, and peak time,

$$2\zeta\omega_n = 0.8, \omega_n = 1, \zeta = 0.4. \text{ Therefore, } \%OS = e^{-\zeta\pi/\sqrt{1-\zeta^2}} \times 100 = 25.38\%, T_s = \frac{4}{\zeta\omega_n} = 10 \text{ sec,}$$

$$T_p = \frac{\pi}{\omega_n\sqrt{1-\zeta^2}} = 3.43 \text{ sec.}$$

48.

Step Response - Data Entry

About

$$\dot{\mathbf{x}} = \mathbf{A}\mathbf{x} + \mathbf{B}u(t)$$

$$y = \mathbf{C}\mathbf{x}$$

Order: 3

$\mathbf{A} =$

	1	2
1	0	1
2	-10	-7
3	0	0

$\mathbf{B} =$

1	0
2	0
3	1

$\mathbf{C} =$

1	2
1	1

$\mathbf{x}(0) =$

1	-1
2	0
3	0

Iteration Interval: .001    Print Interval: .1    Total Time: 4    Calculate

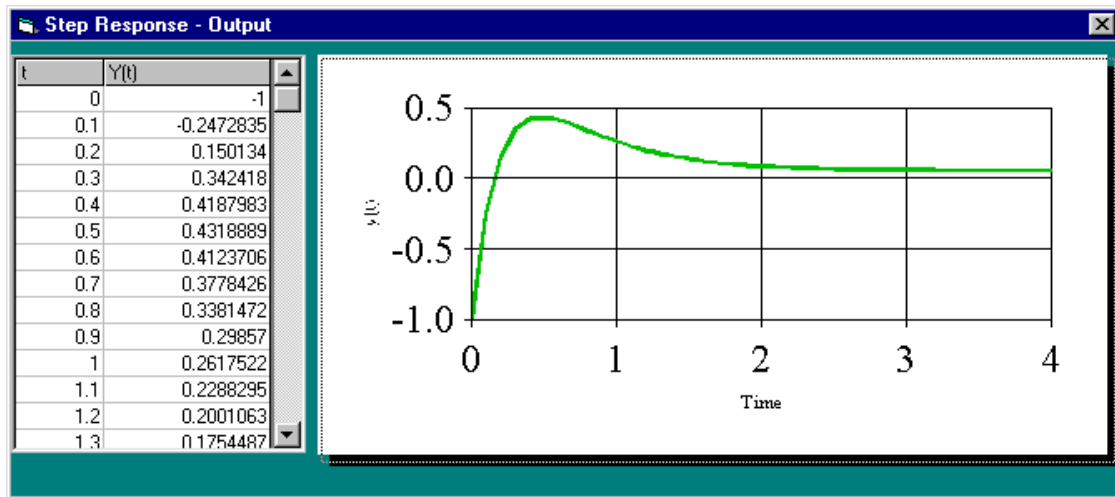

49.

a.  $P(s) = \frac{s+0.5}{s(s+2)(s+5)} = \frac{1/20}{s} + \frac{1/4}{s+2} - \frac{3/10}{s+5}$ . Therefore,  $p(t) = \frac{1}{20} + \frac{1}{4} e^{-2t} - \frac{3}{10} e^{-5t}$ .

b. To represent the system in state space, draw the following block diagram.

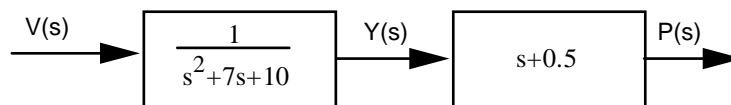

For the first block,

$$\ddot{y} + 7\dot{y} + 10y = v(t)$$

Let  $x_1 = y$ , and  $x_2 = \dot{y}$ . Therefore,

$$\dot{x}_1 = x_2$$

$$\dot{x}_2 = -10x_1 - 7x_2 + v(t)$$

Also,

$$p(t) = 0.5y + \dot{y} = 0.5x_1 + x_2$$

Thus,

$$\dot{\mathbf{x}} = \begin{bmatrix} 0 & 1 \\ -10 & -7 \end{bmatrix} \mathbf{x} + \begin{bmatrix} 0 \\ 1 \end{bmatrix} v; \quad p(t) = \begin{bmatrix} 0.5 & 1 \end{bmatrix} \mathbf{x}$$

c.

**Program:**

```
A=[0 1;-10 -7];
```

```
B=[0;1];
```

```
C=[.5 1];
```

```
D=0;
```

```
S=ss(A,B,C,D)
```

```
step(S)
```

**Computer response:**

```
a =
      x1  x2
x1      0   1
x2     -10  -7
```

```
b =
      u1
x1      0
x2      1
```

```
c =
      x1  x2
y1  0.5   1
```

```
d =
      u1
y1      0
```

Continuous-time model.

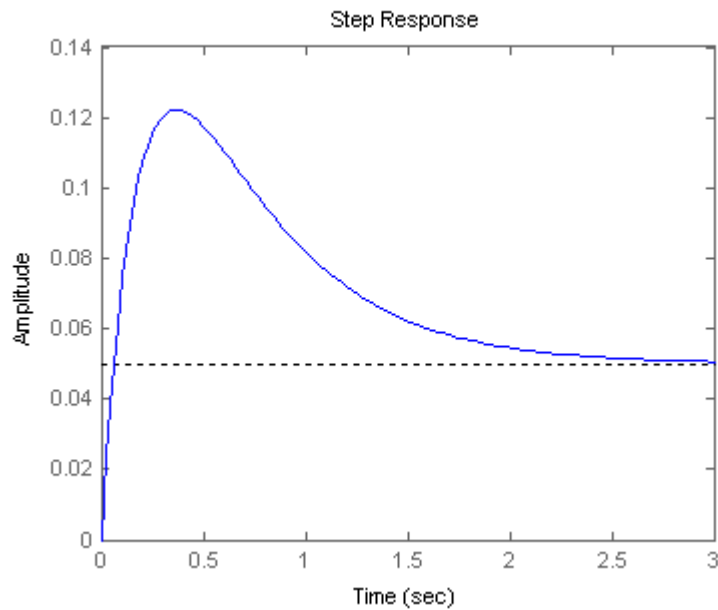

50.

a.  $\omega_n = \sqrt{10} = 3.16$ ;  $2\zeta\omega_n = 4$ . Therefore  $\zeta = 0.632$ .  $\%OS = e^{-\zeta\pi/\sqrt{1-\zeta^2}} * 100 = 7.69\%$ .

$T_s = \frac{4}{\zeta\omega_n} = 2$  seconds.  $T_p = \frac{\pi}{\omega_n\sqrt{1-\zeta^2}} = 1.28$  seconds. From Figure 4.16,  $T_r\omega_n = 1.93$ .

Thus,  $T_r = 0.611$  second. To justify second-order assumption, we see that the dominant poles are at –

$2 \pm j2.449$ . The third pole is at -10, or 5 times further. The second-order approximation is valid.

b.  $G_e(s) = \frac{K}{(s+10)(s^2+4s+10)} = \frac{K}{s^3+14s^2+50s+100}$ . Representing the system in phase-variable form:

$$\mathbf{A} = \begin{bmatrix} 0 & 1 & 0 \\ 0 & 0 & 1 \\ -100 & -50 & -14 \end{bmatrix}; \mathbf{B} = \begin{bmatrix} 0 \\ 0 \\ K \end{bmatrix}; \mathbf{C} = [1 \ 0 \ 0]$$

c.

**Program:**

```
numg=100;
deng=conv([1 10],[1 4 10]);
G=tf(numg,deng)
step(G)
```

**Computer response:**

Transfer function:  
 $\frac{100}{s^3 + 14 s^2 + 50 s + 100}$

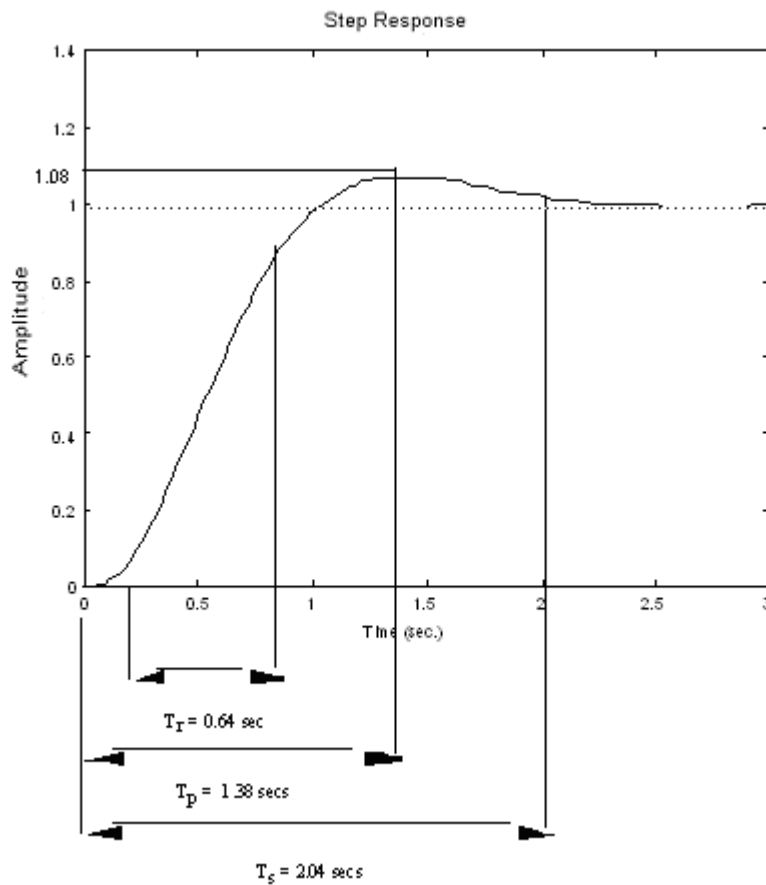

$$\%OS = \frac{(1.08-1)}{1} * 100 = 8\%$$



51.

a.  $\omega_n = \sqrt{0.28} = 0.529$ ;  $2\zeta\omega_n = 1.15$ . Therefore  $\zeta = 1.087$ .

b.  $P(s) = U(s) \frac{7.63 \times 10^{-2}}{s^2 + 1.15s + 0.28}$ , where  $U(s) = \frac{2}{s}$ . Expanding by partial fractions,  $P(s) = \frac{0.545}{s} +$

natural response terms. Thus percent paralysis = 54.5%.

c.  $P(s) = \frac{7.63 \times 10^{-2}}{s(s^2 + 1.15s + 0.28)} = \frac{0.2725}{s} - \frac{0.48444}{s + 0.35} + \frac{0.21194}{s + 0.8}$ .

Hence,  $p(t) = 0.2725 - 0.48444e^{-0.35t} + 0.21194e^{-0.8t}$ . Plotting,

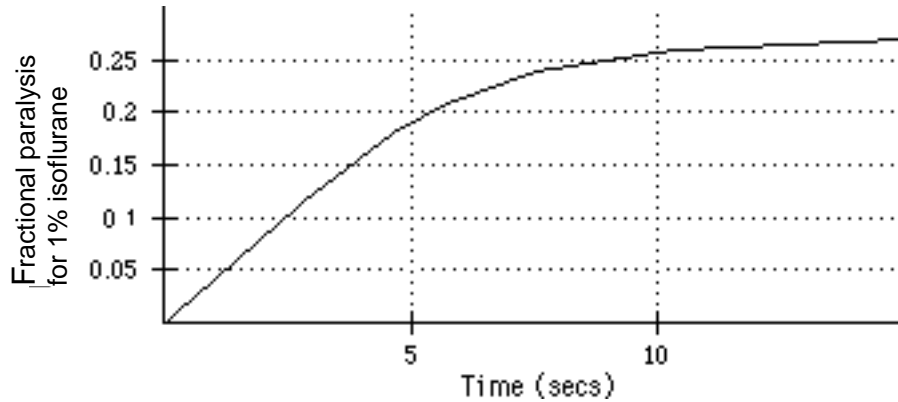

d.  $P(s) = \frac{K}{s} * \frac{7.63 \times 10^{-2}}{s^2 + 1.15s + 0.28} = \frac{1}{s} +$  natural response terms. Therefore,  $\frac{7.63 \times 10^{-2} K}{0.28} = 1$ . Solving

for K,  $K = 3.67\%$ .

52.

a. Writing the differential equation,

$$\frac{dc(t)}{dt} = -k_{10}c(t) + \frac{i(t)}{V_d}$$

Taking the Laplace transform and rearranging,

$$(s + k_{10})C(s) = \frac{I(s)}{V_d}$$

from which the transfer function is found to be

$$\frac{C(s)}{I(s)} = \frac{1}{s + k_{10}V_d}$$

For a step input,  $I(s) = \frac{I_0}{s}$ . Thus the response is

$$C(s) = \frac{\frac{I_0}{V_d}}{s(s + k_{10})} = \frac{I_0}{k_{10}V_d} \left( \frac{1}{s} - \frac{1}{s + k_{10}} \right)$$

Taking the inverse Laplace transform,

$$c(t) = \frac{I_0}{k_{10}V_d}(1 - e^{-k_{10}t})$$

where the steady-state value,  $C_D$ , is

$$C_D = \frac{I_0}{k_{10}V_d}$$

Solving for  $I_R = I_0$ ,

$$I_R = C_D k_{10} V_d$$

b.  $T_R = \frac{2.2}{k_{10}}$  ;  $T_S = \frac{4}{k_{10}}$

c.  $I_R = C_D k_{10} V_d = 12 \frac{\mu\text{g}}{\text{ml}} \times 0.07 \text{ hr}^{-1} \times 0.6 \text{ liters} = 0.504 \frac{\text{mg}}{\text{h}}$

d. Using the equations of part b, where  $k_{10} = 0.07$ ,  $T_R = 31.43 \text{ hrs}$ , and  $T_S = 57.14 \text{ hrs}$ .

53. Consider the un-shifted Laplace transform of the output

$$Y(s) = \frac{2.5(1 + 0.172s)(1 + 0.008s)}{s(1 + 0.07s)^2(1 + 0.05s)^2} = \frac{280.82(s + 5.814)(s + 125)}{s(s + 14.286)^2(s + 20)^2}$$

$$= \frac{A}{s} + \frac{B}{(s + 14.286)^2} + \frac{C}{(s + 14.286)} + \frac{D}{(s + 20)^2} + \frac{E}{(s + 20)}$$

$$A = \frac{280.82(s + 5.814)(s + 125)}{(s + 14.286)^2(s + 20)^2} \Big|_{s=0} = 2.5$$

$$B = \frac{280.82(s + 5.814)(s + 125)}{s(s + 20)^2} \Big|_{s=-14.286} = 564.7$$

$$C = \frac{d}{ds} \frac{280.82(s + 5.814)(s + 125)}{s(s + 20)^2} \Big|_{s=-14.286} = \frac{d}{ds} \frac{280.82s^2 + 36735.2s + 204085.94}{s^3 + 40s^2 + 400s} \Big|_{s=-14.286}$$

$$= \frac{(s^3 + 40s^2 + 400s)(561.64s + 36735.2) - (280.82s^2 + 36735.2s + 204085.94)(3s^2 + 80s + 400)}{(s^3 + 40s^2 + 400s)^2} \Big|_{s=-14.286}$$

$$= -219.7$$

$$D = \frac{280.82(s + 5.814)(s + 125)}{s(s + 14.286)^2} \Big|_{s=-20} = 640.57$$

$$E = \frac{d}{ds} \frac{280.82(s + 5.814)(s + 125)}{s(s + 14.286)^2} \Big|_{s=-20} = \frac{d}{ds} \frac{280.82s^2 + 36735.2s + 204085.94}{s^3 + 28.572s^2 + 204.09s} \Big|_{s=-20}$$

$$= \frac{(s^3 + 28.572s^2 + 204.09s)(561.64s + 36735.2) - (280.82s^2 + 36735.2s + 204085.94)(3s^2 + 57.144s + 204.09)}{(s^3 + 28.572s^2 + 204.09s)^2} \Big|_{s=-20}$$

$$= 217.18$$

thus

$$Y(s) = \frac{2.5}{s} + \frac{564.7}{(s+14.286)^2} - \frac{219.7}{(s+14.286)} + \frac{640.57}{(s+20)^2} + \frac{217.18}{(s+20)}$$

Obtaining the inverse Laplace transform of the latter and delaying the equation in time domain we

get

$$y(t) = [2.5 + 564.7(t - 0.008)e^{-14.286(t-0.008)} - 219.7e^{-14.286(t-0.008)} + 640.57(t - 0.008)e^{-20(t-0.008)} + 217.18e^{-20(t-0.008)}]u(t - 0.008)$$

54.

a. The transfer function can be written as

$$\frac{\theta}{I}(s) = \frac{2.5056(s + 3.33)e^{-0.1s}}{(s + 1)(s^2 + 0.72s + 1.44)}$$

It has poles at  $s = -0.36 \pm j1.145$  and  $s = -1$ . A zero at  $s = -3.33$

The 'far away' pole at  $-1$  is relatively close to the complex conjugate poles as  $0.36 \cdot 5 > 1$  so a dominant pole approximation can't be applied.

b) In time domain the input can be expressed as:

$$i(t) = 250 \mu A (u(t) - u(t - 0.15))$$

Obtaining Laplace transforms this can be expressed as

$$I(s) = 250\mu \frac{1 - e^{-0.15s}}{s}$$

We first obtain the response to an unshifted unit step:

$$\theta(s) = \frac{2.5056(s + 3.33)}{s(s + 1)(s^2 + 0.72s + 1.44)} = \frac{A}{s} + \frac{B}{s + 1} + \frac{Cs + D}{s^2 + 0.72s + 1.44}$$

$$A = \frac{2.5056(s + 3.33)}{(s + 1)(s^2 + 0.72s + 1.44)} \Big|_{s=0} = 5.8$$

$$B = \frac{2.5056(s + 3.33)}{s(s^2 + 0.72s + 1.44)} \Big|_{s=-1} = \frac{2.5056(2.33)}{(-1)(1.72)} = -3.4$$

We will get C and D by equating coefficients. Substituting these two values and multiplying both sides by the denominator we get.

$$2.5056(s + 3.33) = 5.8(s + 1)(s^2 + 0.72s + 1.44) - 3.4s(s^2 + 0.72s + 1.44) + (Cs + D)s(s + 1)$$

$$2.5056(s + 3.33) = 5.8(s^3 + 1.72s^2 + 2.16s + 1.44) - 3.4(s^3 + 0.72s^2 + 1.44s) + (Cs^3 + (C + D)s^2 + Ds)$$

$$2.5056(s + 3.33) = (2.4 + C)s^3 + (7.528 + C + D)s^2 + (10.632 + D)s + 8.352$$

We immediately get C=-2.4 and D=-5.128

So

$$\theta(s) = \frac{5.8}{s} - \frac{3.4}{s + 1} - \frac{2.4s + 5.128}{s^2 + 0.72s + 1.44} = \frac{5.8}{s} - \frac{3.4}{s + 1} - \frac{2.4s + 5.128}{(s + 0.36)^2 + 1.3104}$$

$$= \frac{5.8}{s} - \frac{3.4}{s+1} - \frac{2.4(s+0.15)+4.768}{(s+0.36)^2+1.3104} = \frac{5.8}{s} - \frac{3.4}{s+1} - \frac{2.4(s+0.15)}{(s+0.36)^2+1.3104} - 4.164 \frac{1.145}{(s+0.36)^2+1.3104}$$

Obtaining inverse Laplace transform we get

$$\begin{aligned}\theta(t) &= 5.8 - 3.4e^{-t} - 2.4e^{-0.36t} \cos(1.145t) - 4.164e^{-0.36t} \sin(1.145t) \\ &= 5.8 - 3.4e^{-t} - 2.4e^{-0.36t} \sin(1.145t + 30^\circ)\end{aligned}$$

So the actual (shifted) unit step response is given by

$$\theta(t) = [5.8 - 3.4e^{-(t-0.1)} - 2.4e^{-0.36(t-0.1)} \sin(1.145(t-0.1) + 30^\circ)]u(t-0.1)$$

The response to the pulse is given by:

$$\begin{aligned}\theta(t) &= [1.45m - 0.85me^{-(t-0.1)} - 0.6me^{-0.36(t-0.1)} \sin(1.145(t-0.1) + 30^\circ)]u(t-0.1) - \\ &[1.45m - 0.85me^{-(t-0.25)} - 0.6me^{-0.36(t-0.25)} \sin(1.145(t-0.25) + 30^\circ)]u(t-0.25)\end{aligned}$$

55.

At steady state the input is  $\approx 9V$  and the output is  $\approx 6V$  Thus  $G(0)=6/9=0.667$

The maximum peak is achieved at  $\approx 285\mu$  with a %OS =  $(7.5/6-1)*100 = 25\%$

This corresponds to a damping factor of

$$\zeta = \frac{-\ln(\%OS/100)}{\sqrt{\pi^2 + \ln^2(\%OS/100)}} = \frac{1.3863}{\sqrt{\pi^2 + 1.9218}} \approx 0.4$$

$$\omega_n = \frac{\pi}{T_p \sqrt{1-\zeta^2}} = \frac{\pi}{(285\mu)(0.9165)} = 12027.2$$

So the approximated transfer function is

$$G(s) = \frac{K\omega_n^2}{s^2 + 2\zeta\omega_n s + \omega_n^2} = \frac{0.667 * 12027.2^2}{s^2 + 2 * 0.4 * 12027.2s + 12027.2^2} = \frac{96.5 * 10^6}{s^2 + 9622s + 14.5 * 10^7}$$

56.

The oscillation period is

$$\frac{2\pi}{T} = \omega_n \sqrt{1 - \zeta^2} \quad \text{and from the figure} \quad \frac{T}{2} = 0.0675s - 0.0506s = 0.0169s$$

$$\text{Thus } T = 0.0338\text{sec from which we get } \omega_n \sqrt{1 - \zeta^2} = 185.8931$$

The peaks of the response occur when the 'cos' term of the step response is  $\pm 1$  thus from the figure we have:

$$1 + \frac{e^{-\zeta\omega_n(0.0506)}}{\sqrt{1 - \zeta^2}} = 1.1492 \quad \text{and} \quad 1 - \frac{e^{-\zeta\omega_n(0.0675)}}{\sqrt{1 - \zeta^2}} = 0.9215$$

From which we get

$$\frac{e^{-\zeta\omega_n(0.0506)}}{e^{-\zeta\omega_n(0.0675)}} = \frac{0.1492}{0.0785} = 1.9006 \quad \text{or} \quad e^{-\zeta\omega_n(0.0169)} = 1.9006 \quad \text{or} \quad \zeta\omega_n = 38$$

$$\text{Substituting this result we get } \omega_n \sqrt{1 - \zeta^2} = \frac{38}{\zeta} \sqrt{1 - \zeta^2} = 185.8931$$

$$\text{or } \frac{1444}{\zeta^2} (1 - \zeta^2) = 34556.2284 \quad \text{or} \quad \zeta^2 = 0.0436 \quad \text{or} \quad \zeta = 0.21$$

$$\text{Finally } \omega_n = \frac{38}{\zeta} = 180.9$$

57.

The step input amplitude is the same for both responses so it will just be assumed to be unitary.

For the 'control' response we have:

$$c_{final} = 0.018, \quad M_{pt} = 0.024 \quad \text{from which we get}$$

$$\%OS = \frac{c_{max} - c_{final}}{c_{final}} \times 100\% = \frac{0.024 - 0.018}{0.018} \times 100\% = 33.33\%$$

$$\zeta = \frac{-\ln(\%OS/100)}{\sqrt{\pi^2 + \ln^2(\%OS/100)}} = \frac{-\ln(0.333)}{\sqrt{\pi^2 + \ln^2(0.333)}} = 0.33$$

$$\omega_n = \frac{\pi}{T_p \sqrt{1 - \zeta^2}} = \frac{\pi}{0.1 \sqrt{1 - 0.333^2}} = 33.3$$

Leading a transfer function

$$G_c(s) = \frac{1108.9}{s^2 + 22s + 1108.9}$$

Similarly for the 'hot tail':

$$c_{final} = 0.023, M_{pt} = 0.029$$

$$\%OS = \frac{0.029 - 0.023}{0.023} \times 100\% = 26.1\%$$

$$\zeta = \frac{-\ln(0.261)}{\sqrt{\pi^2 + \ln^2(0.261)}} = 0.393$$

$$\omega_n = \frac{\pi}{T_p \sqrt{1 - \zeta^2}} = \frac{\pi}{0.1 \sqrt{1 - 0.261^2}} = 34.17$$

$$G_h(s) = \frac{1167.6}{s^2 + 26.9s + 1167.6}$$

Using MATLAB:

```
>> syms s
```

```
>> s=tf('s')
```

Transfer function:

```
s
```

```
>> Gc = 1108.89/(s^2+22*s+1108.89);
```

```
>> Gh = 1167.6/(s^2+26.9*s+1167.6);
```

```
>> step(Gc,Gh)
```

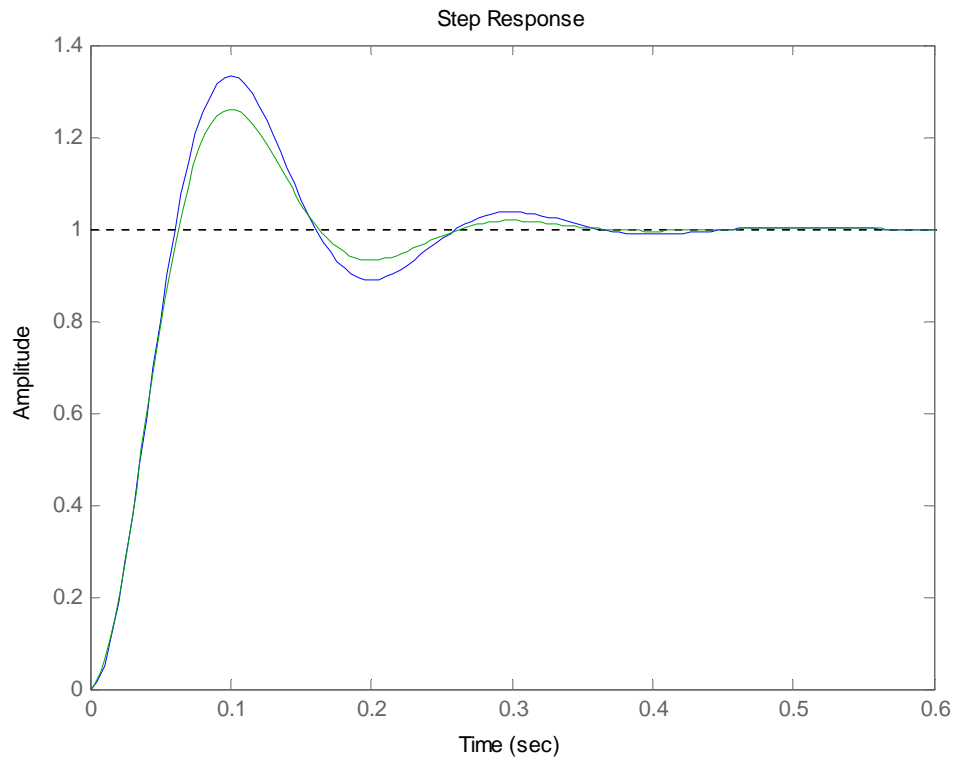

Both responses are equivalent if error tolerances are considered.

**58.**

The original transfer function has zeros at  $s = -7200 \pm j7400$

And poles at  $s = -1900 \pm j4500$ ;  $s = -120 \pm j1520$

With  $G(0) = 0.1864$

The dominant poles are those with real parts at -120, so a real pole is added at

-1200 giving the following approximation:

$$G(s) \approx 0.1864 \frac{(1200)(2324.8 \times 10^3)}{106.6 \times 10^6} \frac{(s^2 - 14400s + 106.6 \times 10^6)}{(s^2 + 240s + 2324.8 \times 10^3)(s + 1200)}$$

$$= \frac{4.8782(s^2 - 14400s + 106.6 \times 10^6)}{(s^2 + 240s + 2324.8 \times 10^3)(s + 1200)}$$

Using MATLAB:

```
>> syms s
```

```
>> s=tf('s');
```



```

>>G=9.7e4*(s^2-14400*s+106.6e6)...
    /(s^2+3800*s+23.86e6)/(s^2+240*s+2324.8e3);
>> Gdp=4.8782*(s^2-14400*s+106.6e6)/(s^2+240*s+2324.8e3)/(s+1200);
>> step(G,Gdp)

```

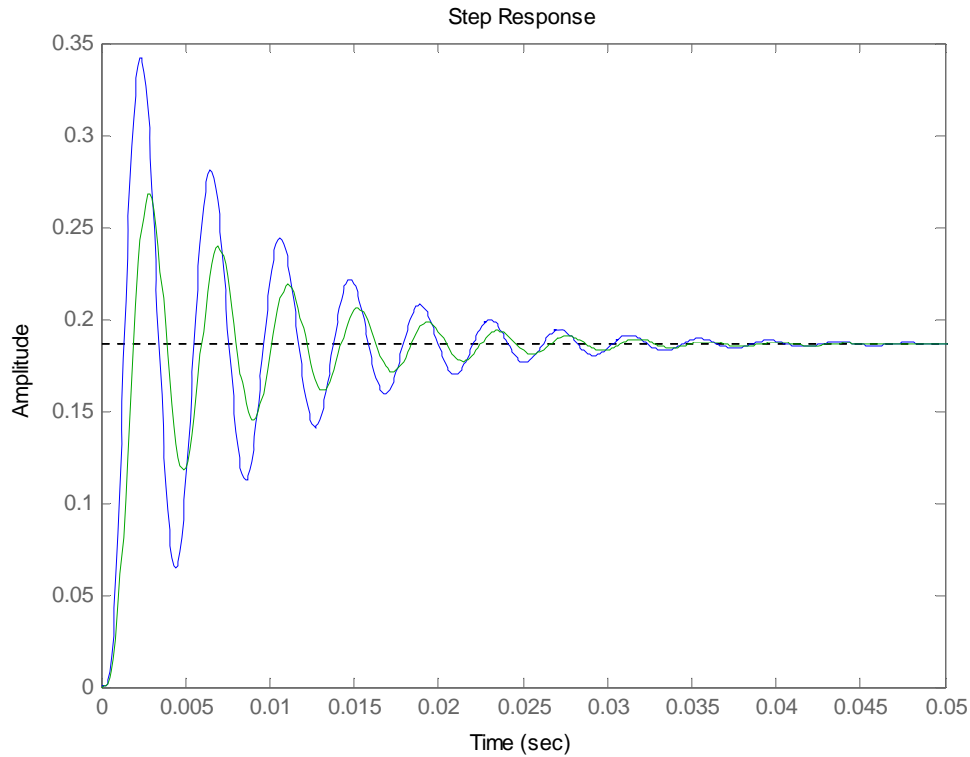

Both responses differ because the original non-dominant poles are very close to the complex pair of zeros.

**59.**

$M(s)$  requires at least 4 'far away' poles that are added a decade beyond all original poles and zeros.

This gives

$$M(s) = \frac{(s + 0.009)^2 (s^2 + 0.018s + 0.0001)}{9.72 \times 10^{-8} (s + 0.0001)(1 + s/0.1)^4} = \frac{1028.81(s + 0.009)^2 (s^2 + 0.018s + 0.0001)}{(s + 0.0001)(s + 0.1)^4}$$

60.

$$\zeta = \frac{-\ln(\%OS/100)}{\sqrt{\pi^2 + \ln^2(\%OS/100)}} = \frac{-\ln(0.30)}{\sqrt{\pi^2 + \ln^2(0.30)}} = 0.36$$

$$\omega_n = \frac{\pi}{T_p \sqrt{1 - \zeta^2}} = \frac{\pi}{127 \sqrt{1 - 0.30^2}} = 0.026$$

$$G(s) = \frac{\omega_n^2}{s^2 + 2\zeta\omega_n s + \omega_n^2} = \frac{0.00067}{s^2 + 0.0187s + 0.00067}$$

61.

a. Let the impulse response of  $T(s)$  be  $h(t)$ . We have that

$$H(s) = \frac{450}{(s+5)(s+20)} = \frac{A}{s+5} + \frac{B}{s+20}$$

$$A = \frac{450}{s+20} \Big|_{s=-5} = 30; \quad B = \frac{450}{s+5} \Big|_{s=-20} = -30$$

$$H(s) = \frac{30}{s+5} - \frac{30}{s+20}. \text{ Obtaining the inverse Laplace transform we get}$$

$$h(t) = 30e^{-5t} - 30e^{-20t}$$

b. Let the step response of the system be  $g(t)$ . We have that

$$g(t) = \int_0^t h(t) dt = \int_0^t 30e^{-5t} dt - \int_0^t 30e^{-20t} dt = -\frac{30}{5}e^{-5t} \Big|_0^t - \frac{30}{-20}e^{-20t} \Big|_0^t$$

$$= -6(e^{-5t} - 1) + 1.5(e^{-20t} - 1) = 4.5 - 6e^{-5t} + 1.5e^{-20t}$$

$$\text{c. } G(s) = \frac{450}{s(s+5)(s+20)} = \frac{A}{s} + \frac{B}{s+5} + \frac{C}{s+20}$$

$$A = \frac{450}{(s+5)(s+20)} \Big|_{s=0} = 4.5; \quad B = \frac{450}{s(s+20)} \Big|_{s=-5} = -6; \quad C = \frac{450}{s(s+5)} \Big|_{s=-20} = 1.5$$

$$\text{Leading } G(s) = \frac{4.5}{s} - \frac{6}{s+5} + \frac{1.5}{s+20}. \text{ After the inverse Laplace we get}$$

$$g(t) = 4.5 - 6e^{-5t} + 1.5e^{-20t}$$

62.

a. The poles given by  $s^2 + 8.99 \times 10^{-3}s + 3.97 \times 10^{-3} = 0$  have an  $\omega_n = 0.063 \text{ rad/sec}$  and  $\zeta = 0.0714$

The poles given by  $s^2 + 4.21s + 18.23 = 0$  have an  $\omega_n = 4.27 \text{ rad/sec}$  and  $\zeta = 0.493$ . Thus the former represent the Phugoid and the latter the Short Period modes.

b. In the original we have  $\frac{\theta}{\delta_e}(0) = -4.85$  so the Phugoid approximation is given by:

$$\frac{\theta}{\delta_e} \approx -\frac{1.965(s + 0.0098)}{(s^2 + 8.99 \times 10^{-3}s + 3.97 \times 10^{-3})}$$

c.

```
>> syms s
```

```
>> s=tf('s');
```

```
>> G=-26.12*(s+0.0098)*(s+1.371)/(s^2+8.99e-3*s+3.97e-3)/(s^2+4.21*s+18.23);
```

```
>> Gphug=-1.965*(s+0.0098)/(s^2+8.99e-3*s+3.97e-3);
```

```
>> step(G,Gphug)
```

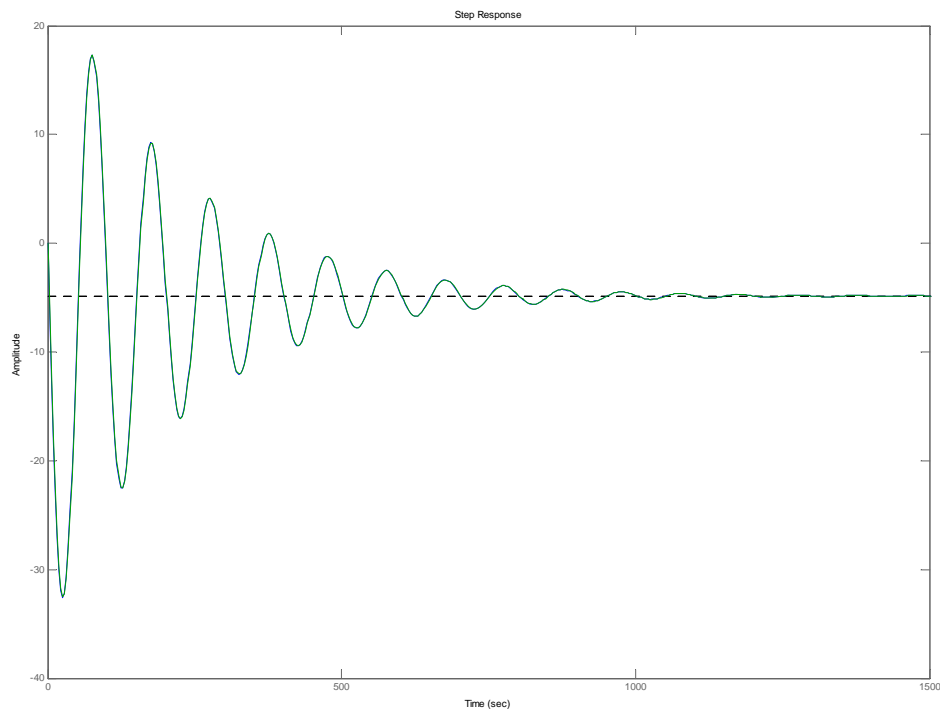

Both responses are indistinguishable.

63.

a.

**Program**

```
numg=[33 202 10061 24332 170704];
deng=[1 8 464 2411 52899 167829 913599 1076555];
G=tf(numg,deng)
[K,p,k]=residue(numg,deng)
```

**Computer Response**

K =

```
0.0018 + 0.0020i
0.0018 - 0.0020i
-0.1155 - 0.0062i
-0.1155 + 0.0062i
0.0077 - 0.0108i
0.0077 + 0.0108i
0.2119
```

p =

```
-1.6971 +16.4799i
-1.6971 -16.4799i
-0.5992 +12.1443i
-0.5992 -12.1443i
-1.0117 + 4.2600i
-1.0117 - 4.2600i
-1.3839
```

k =

[ ]

**b.**Therefore, an approximation to  $G(s)$  is:

$$G(s) = \frac{0.2119}{s+1.3839}$$

**c.****Program**

```
numg=[33 202 10061 24332 170704];
deng=[1 8 464 2411 52899 167829 913599 1076555];
G=tf(numg,deng);
numga=0.2119;
denga=[1 1.3839];
```

```

Ga=tf(numga,denga);
step(G)
hold on
step(Ga)

```

### Computer Response

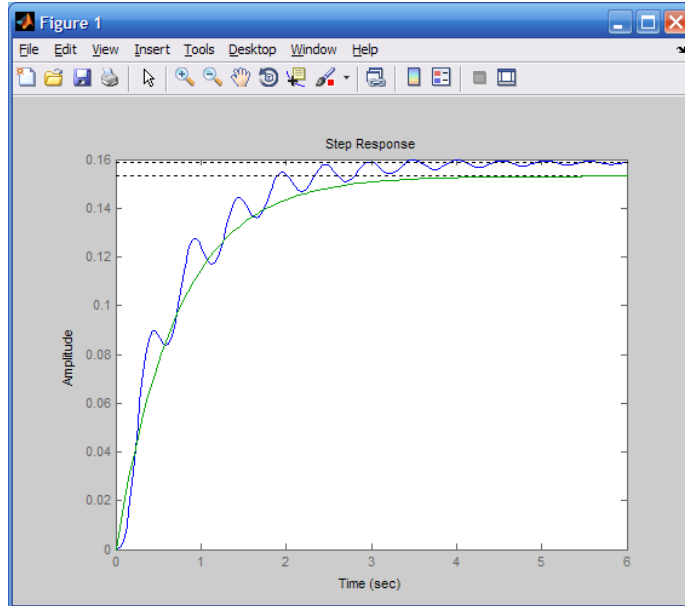

Approximation does not show oscillations and is slightly off of final value.

64.

### Computer Response

Transfer function:

$$\begin{aligned}
 & s^{15} + 1775 s^{14} + 1.104e006 s^{13} + 2.756e008 s^{12} + 2.272e010 s^{11} \\
 & + 7.933e011 s^{10} + 1.182e013 s^9 + 6.046e013 s^8 + 1.322e014 s^7 \\
 & + 1.238e014 s^6 + 3.977e013 s^5 + 5.448e012 s^4 + 3.165e011 s^3 \\
 & + 6.069e009 s^2 + 4.666e007 s + 1.259e005
 \end{aligned}$$

---

$$\begin{aligned}
 & 31.62 s^{17} + 4.397e004 s^{16} + 1.929e007 s^{15} + 2.941e009 s^{14} \\
 & + 1.768e011 s^{13} + 4.642e012 s^{12} + 5.318e013 s^{11} + 2.784e014 s^{10} \\
 & + 7.557e014 s^9 + 1.238e015 s^8 + 1.356e015 s^7 + 8.985e014 s^6 \\
 & + 2.523e014 s^5 + 3.179e013 s^4 + 1.732e012 s^3 + 3.225e010 s^2 \\
 & + 2.425e008 s + 6.414e005
 \end{aligned}$$

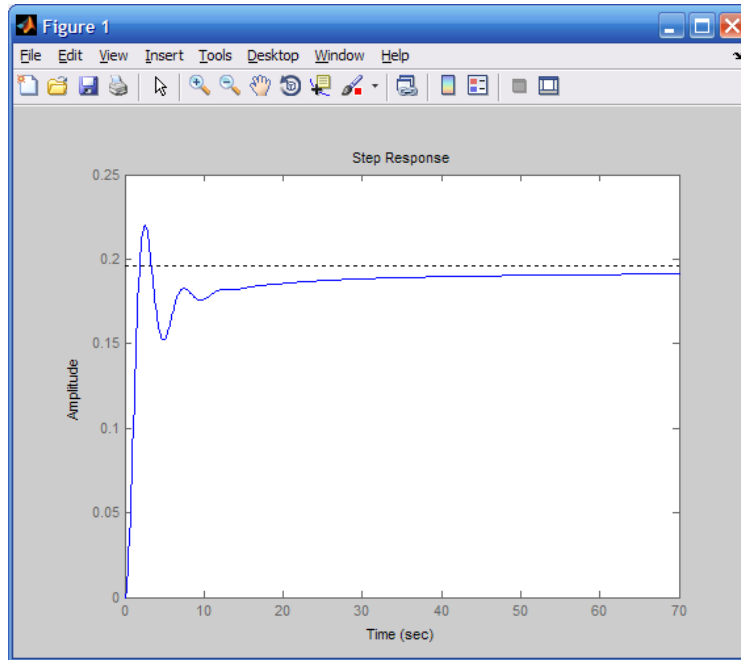

65.

a. To find the step responses for these two processes,  $y_a(t)$  and  $y_p(t)$ , we consider first the un-shifted Laplace transform of their outputs for  $X_d(s) = X_p(s) = 1/s$ :

$$Y_a^*(s) = \frac{14.49}{s(1478.26s + 1)} = \frac{9.8 \times 10^{-3}}{s(s + 6.77 \times 10^{-4})} = \frac{A}{s} + \frac{B}{(s + 6.77 \times 10^{-4})} \quad (1),$$

$$\text{where } A = \left. \frac{9.8 \times 10^{-3}}{s + 6.77 \times 10^{-4}} \right|_{s=0} = 14.49 \text{ and}$$

$$B = \left. \frac{9.8 \times 10^{-3}}{s} \right|_{s=-6.77 \times 10^{-4}} = -14.49 \quad (2)$$

Substituting the values of  $A$  and  $B$  into equation (1) gives:

$$Y_a^*(s) = \frac{A}{s} + \frac{B}{(s + 6.76 \times 10^{-4})} = 14.49 \left( \frac{1}{s} - \frac{1}{(s + 6.76 \times 10^{-4})} \right) \quad (3)$$

Taking the inverse Laplace transform of  $Y_a^*(s)$  and delaying the resulting response in the time domain by 4 seconds, we get:

$$y_a(t) = 14.49[1 - e^{-6.76 \times 10^{-4}(t-4)}] u(t-4) \quad (4)$$

Noting that the denominator of  $G_p(s)$  can be factored into

$(s + 0.174 \times 10^{-3})(s + 6.814 \times 10^{-3})$ , we have:

$$Y_p^*(s) = \frac{1.716 \times 10^{-5}}{s(s + 0.174 \times 10^{-3})(s + 6.814 \times 10^{-3})} = \frac{C}{s} + \frac{D}{(s + 0.174 \times 10^{-3})} + \frac{E}{(s + 6.814 \times 10^{-3})} \quad (5),$$

$$\text{where: } C = \left. \frac{1.716 \times 10^{-5}}{(s + 0.174 \times 10^{-3})(s + 6.814 \times 10^{-3})} \right|_{s=0} = 14.48;$$

$$D = \left. \frac{1.716 \times 10^{-5}}{s(s + 6.814 \times 10^{-3})} \right|_{s = -0.174 \times 10^{-3}} = -14.85;$$

$$E = \left. \frac{1.716 \times 10^{-5}}{s(s + 0.174 \times 10^{-3})} \right|_{s = -6.814 \times 10^{-3}} = 0.37. \quad (6)$$

Substituting the values of  $C$ ,  $D$  and  $E$  into equation (5) and simplifying gives:

$$Y_p^*(s) = \frac{14.48}{s} - \frac{14.85}{(s + 0.174 \times 10^{-3})} + \frac{0.37}{(s + 6.814 \times 10^{-3})} = 14.48 \left( \frac{1}{s} - \frac{1.0256}{(s + 0.174 \times 10^{-3})} + \frac{0.0256}{(s + 6.814 \times 10^{-3})} \right) \quad (7)$$

Taking the inverse Laplace transform of  $Y_p^*(s)$  and delaying the resulting response in the time

domain by 30 seconds, we get:

$$y_p(t) = 14.48[1 - 1.0256e^{-0.174 \times 10^{-3}(t-30)} + 0.0256e^{-6.814 \times 10^{-3}(t-30)}]u(t-30) \quad (8)$$

b. Using Simulink to model the two processes described above,  $y_a(t)$  and  $y_p(t)$  were output to the "workspace." Matlab plot commands were then utilized to plot  $y_a(t)$  and  $y_p(t)$  on a single graph, which is shown below.

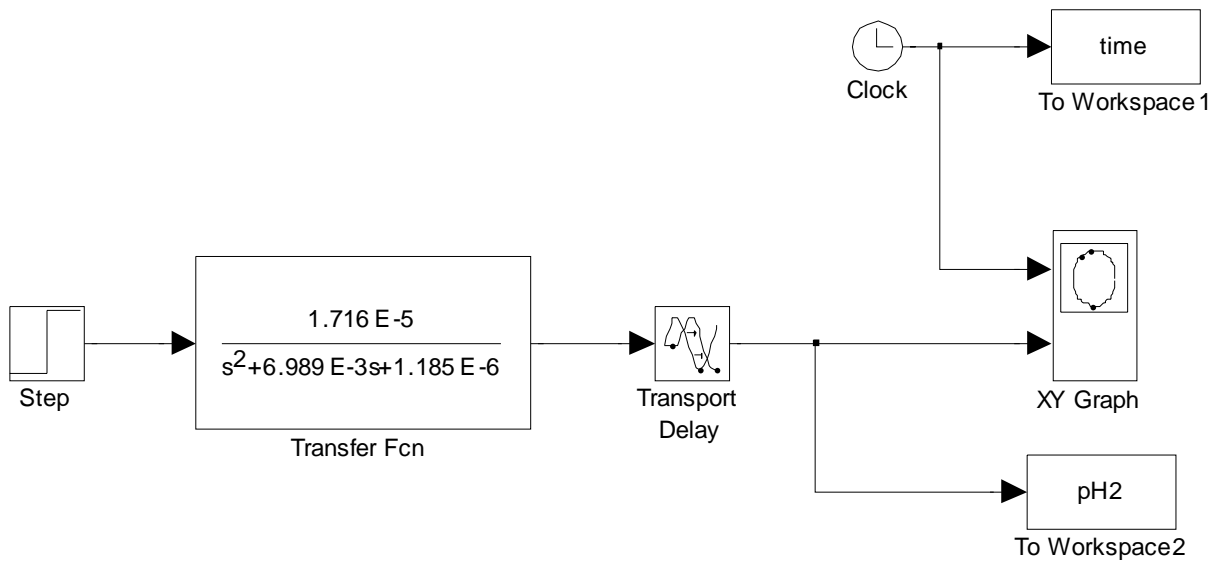
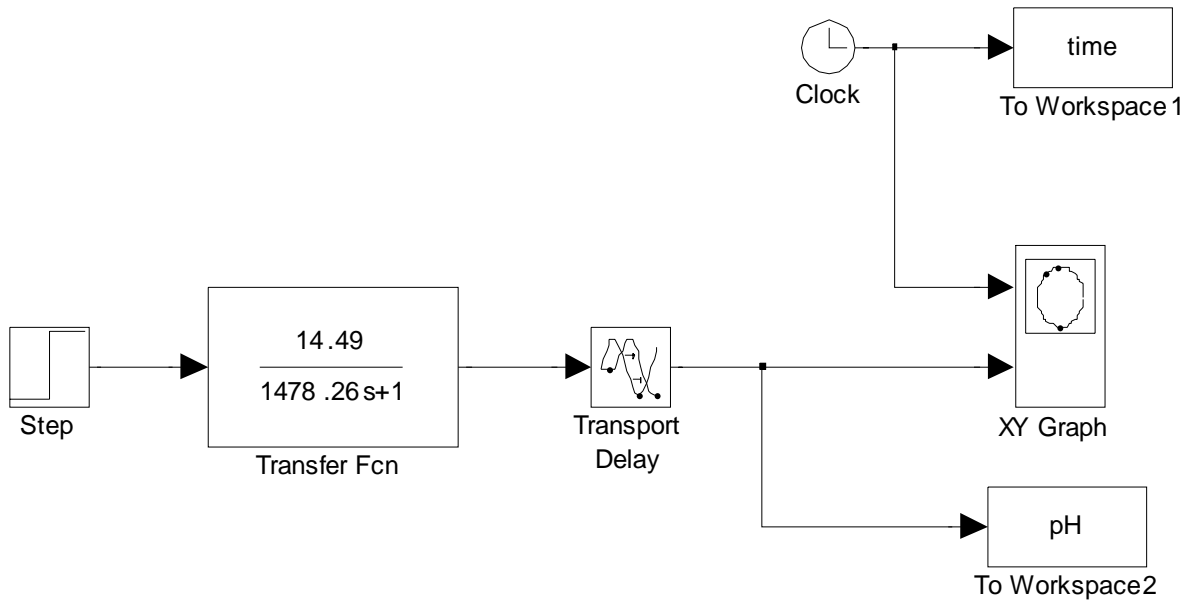



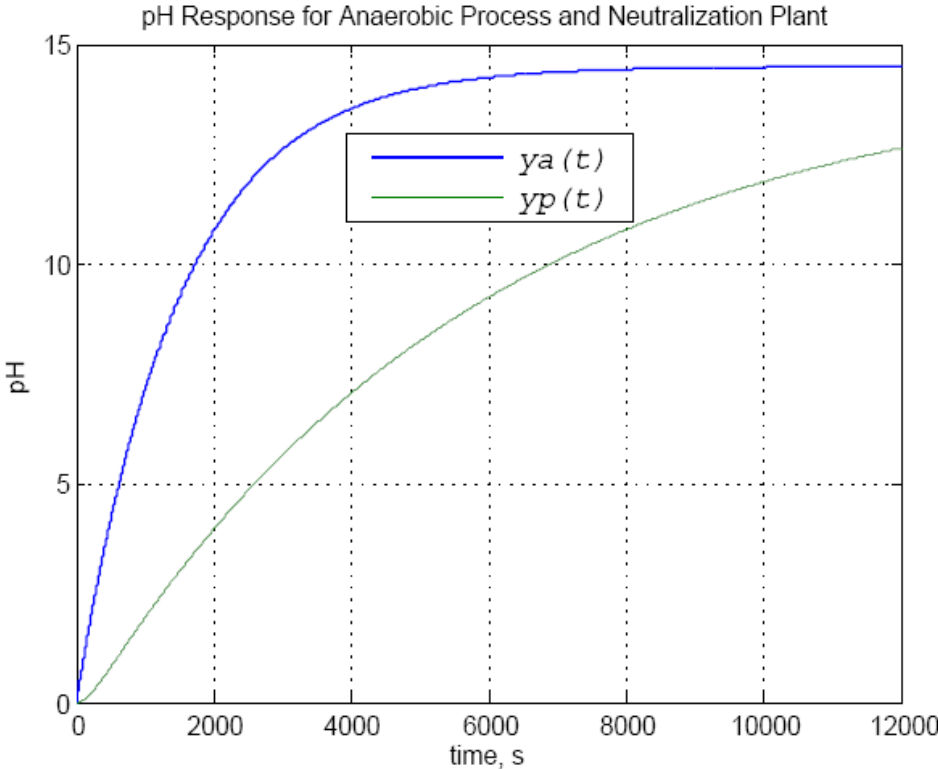

66.

a.

```
>> A=[-8.792e-3 0.56e-3 -1e-3 -13.79e-3; -0.347e-3 -11.7e-3 -0.347e-3 0; 0.261 -20.8e-3 -96.6e-3
0; 0 0 1 0]
```

A =

```
-0.0088 0.0006 -0.0010 -0.0138
-0.0003 -0.0117 -0.0003 0
0.2610 -0.0208 -0.0966 0
0 0 1.0000 0
```

&gt;&gt; eig(A)

ans =

```
-0.1947
0.0447 + 0.1284i
0.0447 - 0.1284i
-0.0117
```

b.

Given the eigenvalues, the state-transition matrix will be of the form

$$\Phi(t) = \begin{bmatrix} K_{11} & K_{12} & K_{13} & K_{14} \\ K_{21} & K_{22} & K_{23} & K_{24} \\ K_{31} & K_{32} & K_{33} & K_{34} \\ K_{41} & K_{42} & K_{43} & K_{44} \end{bmatrix} \quad \text{with}$$

$$K_{ij} = K_{ij1} e^{-0.1947 t} + K_{ij2} e^{-0.0117 t} + K_{ij3} e^{+0.0447 t} \sin(0.1284 t) + K_{ij4} e^{+0.0447 t} \cos(0.1284 t)$$

Thus 64 constants have to be found.

67.

a. The equations are rewritten as

$$\frac{di_L}{dt} = -\frac{1-d}{L}u_C + \frac{1}{L}E_s$$

$$\frac{du_C}{dt} = \frac{1-d}{C}i_L - \frac{1}{RC}u_C$$

from which we obtain

$$\begin{bmatrix} \frac{di_L}{dt} \\ \frac{du_C}{dt} \end{bmatrix} = \begin{bmatrix} 0 & -\frac{1-d}{L} \\ \frac{1-d}{C} & -\frac{1}{RC} \end{bmatrix} \begin{bmatrix} i_L \\ u_C \end{bmatrix} + \begin{bmatrix} \frac{1}{L} \\ 0 \end{bmatrix} E_s$$

$$y = \begin{bmatrix} 0 & 1 \end{bmatrix} \begin{bmatrix} i_L \\ u_C \end{bmatrix}$$

b. To obtain the transfer function we first calculate

$$(s\mathbf{I} - \mathbf{A})^{-1} = \begin{bmatrix} s & \frac{1-d}{L} \\ -\frac{1-d}{C} & s + \frac{1}{RC} \end{bmatrix}^{-1} = \frac{\begin{bmatrix} s + \frac{1}{RC} & -\frac{1-d}{L} \\ \frac{1-d}{C} & s \end{bmatrix}}{s(s + \frac{1}{RC}) + \frac{(1-d)^2}{LC}}$$

So

$$G(s) = \mathbf{C}(s\mathbf{I} - \mathbf{A})^{-1}\mathbf{B} = \begin{bmatrix} 0 & 1 \end{bmatrix} \frac{\begin{bmatrix} s + \frac{1}{RC} & -\frac{1-d}{L} \\ \frac{1-d}{C} & s \end{bmatrix}}{s(s + \frac{1}{RC}) + \frac{(1-d)^2}{LC}} \begin{bmatrix} \frac{1}{L} \\ 0 \end{bmatrix}$$

$$= \frac{\begin{bmatrix} \frac{1-d}{C} & s \end{bmatrix}}{s^2 + \frac{1}{RC}s + \frac{(1-d)^2}{LC}} \begin{bmatrix} \frac{1}{L} \\ 0 \end{bmatrix} = \frac{\frac{1-d}{LC}}{s^2 + \frac{1}{RC}s + \frac{(1-d)^2}{LC}}$$

68.

a. We have  $(s\mathbf{I} - \mathbf{A}) = \begin{bmatrix} s + 8.34 & 2.26 \\ -1 & s \end{bmatrix}$  and

$$(s\mathbf{I} - \mathbf{A})^{-1} = \frac{\begin{bmatrix} s & -2.26 \\ 1 & s + 8.34 \end{bmatrix}}{s^2 + 8.34s + 2.26} = \frac{\begin{bmatrix} s & -2.26 \\ 1 & s + 8.34 \end{bmatrix}}{(s + 0.28)(s + 8.06)}$$

We first find  $\mathcal{L}^{-1} \left\{ \frac{1}{(s + 0.28)(s + 8.06)} \right\}$

$$\frac{1}{(s + 0.28)(s + 8.06)} = \frac{K_1}{s + 0.28} + \frac{K_2}{s + 8.06}$$

$$K_1 = \frac{1}{s + 8.06} \Big|_{s=-0.28} = 0.129; \quad K_2 = \frac{1}{s + 0.28} \Big|_{s=-8.06} = -0.129 \text{ so}$$

$$\mathcal{L}^{-1} \left\{ \frac{1}{(s + 0.28)(s + 8.06)} \right\} = 0.129e^{-0.28t} - 0.129e^{-8.06t}$$

Follows that

$$\mathcal{L}^{-1} \left\{ \frac{-2.26}{(s + 0.28)(s + 8.06)} \right\} = -2.26 \mathcal{L}^{-1} \left\{ \frac{1}{(s + 0.28)(s + 8.06)} \right\} = -0.292e^{-0.28t} + 0.292e^{-8.06t}$$

$$\mathcal{L}^{-1} \left\{ \frac{s}{(s + 0.28)(s + 8.06)} \right\} = \frac{d}{dt} \mathcal{L}^{-1} \left\{ \frac{1}{(s + 0.28)(s + 8.06)} \right\} = -0.036e^{-0.28t} + 1.04e^{-8.06t}$$

And

$$\begin{aligned} \mathcal{L}^{-1} \left\{ \frac{s + 8.34}{(s + 0.28)(s + 8.06)} \right\} &= \mathcal{L}^{-1} \left\{ \frac{s}{(s + 0.28)(s + 8.06)} \right\} + 8.34 \mathcal{L}^{-1} \left\{ \frac{1}{(s + 0.28)(s + 8.06)} \right\} \\ &= -0.036e^{-0.28t} + 1.04e^{-8.06t} + 1.076e^{-0.28t} - 1.076e^{-8.06t} = 1.04e^{-0.28t} - 0.036e^{-8.06t} \end{aligned}$$

Finally the state transition matrix is given by:

$$\Phi(t) = \begin{bmatrix} -0.036e^{-0.28t} + 1.04e^{-8.06t} & -0.292e^{-0.28t} + 0.292e^{-8.06t} \\ 0.129e^{-0.28t} - 0.129e^{-8.06t} & 1.04e^{-0.28t} - 0.036e^{-8.06t} \end{bmatrix}$$

b.

$$\Phi(t)\mathbf{B} = \begin{bmatrix} -0.036e^{-0.28t} + 1.04e^{-8.06t} \\ 0.129e^{-0.28t} - 0.129e^{-8.06t} \end{bmatrix}$$

$$\mathbf{C}\Phi(t)\mathbf{B} = -0.451e^{-0.28t} + 13.04e^{-8.06t} + 0.292e^{-0.28t} - 0.292e^{-8.06t} = -0.159e^{-0.28t} + 12.748e^{-8.06t}$$

Since  $u(t) = 1$ 

$$\begin{aligned} y(t) &= \int_0^t \mathbf{C}\Phi(t-\tau)\mathbf{B}d\tau = \int_0^t [-0.159e^{-0.28(t-\tau)} + 12.748e^{-8.06(t-\tau)}]d\tau \\ &= -0.159e^{-0.28t} \int_0^t e^{0.28\tau} d\tau + 12.748e^{-8.06t} \int_0^t e^{8.06\tau} d\tau \\ &= \frac{-0.159}{0.28} e^{-0.28t} e^{0.28\tau} + \frac{12.748}{8.06} e^{-8.06t} e^{8.06\tau} \Big|_0^t \\ &= -0.568[1 - e^{-0.28t}] + 1.582[1 - e^{-8.06t}] = 1.014 + 0.568e^{-0.28t} - 1.582e^{-8.06t} \end{aligned}$$

c.

&gt;&gt; A=[-8.34 -2.26; 1 0];

&gt;&gt; B = [1; 0];

&gt;&gt; C = [12.54 2.26];

&gt;&gt; D = 0;

&gt;&gt; t = linspace(0,15,1000);

&gt;&gt; y1 = step(A,B,C,D,1,t);

&gt;&gt; y2 = 1.014+0.568\*exp(-0.28.\*t)-1.582\*exp(-8.06.\*t);

&gt;&gt; plot(t,y1,t,y2)

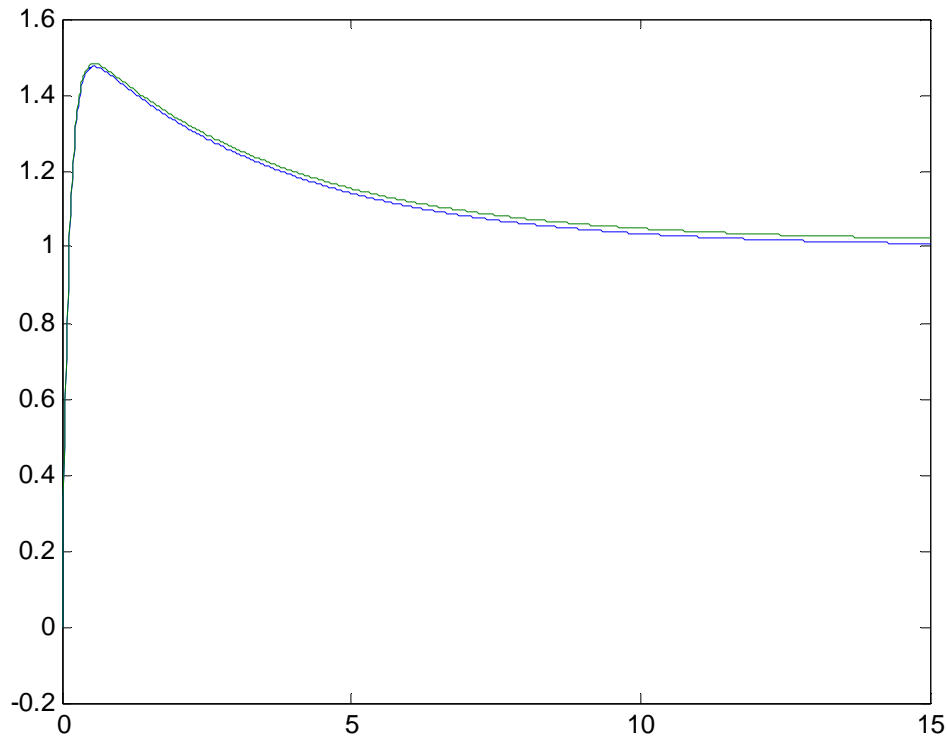

## SOLUTIONS TO DESIGN PROBLEMS

69.

Writing the equation of motion,  $(f_v s + 2)X(s) = F(s)$ . Thus, the transfer function is

$$\frac{X(s)}{F(s)} = \frac{1/f_v}{s + \frac{2}{f_v}}. \text{ Hence, } T_s = \frac{4}{a} = \frac{4}{\frac{2}{f_v}} = 2f_v, \text{ or } f_v = \frac{T_s}{2}.$$

70.

The transfer function is,  $F(s) = \frac{1/M}{s^2 + \frac{1}{M}s + \frac{K}{M}}$ . Now,  $T_s = 4 = \frac{4}{|\text{Re}|} = \frac{4}{\frac{1}{2M}}$ . Thus,

$M = \frac{1}{2}$ . Substituting the value of M in the denominator of the transfer function yields,

$s^2 + 2s + 2K$ . Identify the roots  $s_{1,2} = -1 \pm j\sqrt{2K-1}$ . Using the imaginary part and substituting

into the peak time equation yields  $T_p = 1 = \frac{\pi}{|\text{Im}|} = \frac{\pi}{\sqrt{2K-1}}$ , from which  $K = 5.43$ .

71.

Writing the equation of motion,  $(Ms^2 + f_v s + 1)X(s) = F(s)$ . Thus, the transfer function is  $\frac{X(s)}{F(s)} = \frac{1/M}{s^2 + \frac{f_v}{M}s + \frac{1}{M}}$ . Since  $T_s = 10 = \frac{4}{\zeta\omega_n}$ ,  $\zeta\omega_n = 0.4$ . But,  $\frac{f_v}{M} = 2\zeta\omega_n = 0.8$ . Also,

from Eq. (4.39) 17% overshoot implies  $\zeta = 0.491$ . Hence,  $\omega_n = 0.815$ . Now,  $1/M = \omega_n^2 = 0.664$ .

Therefore,  $M = 1.51$ . Since  $\frac{f_v}{M} = 2\zeta\omega_n = 0.8$ ,  $f_v = 1.21$ .

72.

Writing the equation of motion:  $(Js^2 + s + K)\theta(s) = T(s)$ . Therefore the transfer function is

$$\frac{\theta(s)}{T(s)} = \frac{\frac{1}{J}}{s^2 + \frac{1}{J}s + \frac{K}{J}}$$

$$\zeta = \frac{-\ln\left(\frac{\%OS}{100}\right)}{\sqrt{\pi^2 + \ln^2\left(\frac{\%OS}{100}\right)}} = 0.358.$$

$$T_s = \frac{4}{\zeta\omega_n} = \frac{4}{\frac{1}{2J}} = 8J = 3.$$

Therefore  $J = \frac{3}{8}$ . Also,  $T_s = 3 = \frac{4}{\zeta\omega_n} = \frac{4}{(0.358)\omega_n}$ . Hence,  $\omega_n = 3.724$ . Now,  $\frac{K}{J} = \omega_n^2 = 13.868$ .

Finally,  $K = 5.2$ .

73.

Writing the equation of motion

$$[s^2 + D(5)^2s + \frac{1}{4}(10)^2]\theta(s) = T(s)$$

The transfer function is

$$\frac{\theta(s)}{T(s)} = \frac{1}{s^2 + 25Ds + 25}$$

Also,

$$\zeta = \frac{-\ln\left(\frac{\%OS}{100}\right)}{\sqrt{\pi^2 + \ln^2\left(\frac{\%OS}{100}\right)}} = 0.358$$

and

$$2\zeta\omega_n = 2(0.358)(5) = 25D$$

Therefore  $D = 0.14$ .

74.

The equivalent circuit is:

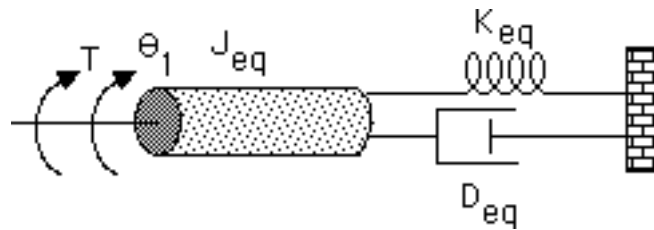

where  $J_{eq} = 1 + (\frac{N_1}{N_2})^2$ ;  $D_{eq} = (\frac{N_1}{N_2})^2$ ;  $K_{eq} = (\frac{N_1}{N_2})^2$ . Thus,

$$\frac{\theta_1(s)}{T(s)} = \frac{1}{J_{eq}s^2 + D_{eq}s + K_{eq}} \text{ . Letting } \frac{N_1}{N_2} = n \text{ and substituting the above values into the transfer}$$

function,

$$\frac{\theta_1(s)}{T(s)} = \frac{1}{s^2 + \frac{n^2}{1+n^2}s + \frac{n^2}{1+n^2}} \text{ . Therefore, } \zeta\omega_n = \frac{n^2}{2(1+n^2)} \text{ . Finally, } T_s = \frac{4}{\zeta\omega_n} = \frac{8(1+n^2)}{n^2} = 16. \text{ Thus}$$

$n = 1$ .

75.

Let the rotation of the shaft with gear  $N_2$  be  $\theta_L(s)$ . Assuming that all rotating load has been reflected

to the  $N_2$  shaft,  $(J_{eqL}s^2 + D_{eqL}s + K)\theta_L(s) + F(s)r = T_{eq}(s)$ , where  $F(s)$  is the force from the translational system,  $r = 2$  is the radius of the rotational member,  $J_{eqL}$  is the equivalent inertia at the  $N_2$  shaft, and  $D_{eqL}$  is the equivalent damping at the  $N_2$  shaft. Since  $J_{eqL} = 1(2)^2 + 1 = 5$  and  $D_{eqL} = 1(2)^2 = 4$ , the equation of motion becomes,  $(5s^2 + 4s + K)\theta_L(s) + 2F(s) = T_{eq}(s)$ . For the translational system  $(Ms^2 + s)X(s) = F(s)$ . Substituting  $F(s)$  into the rotational equation of motion,  $(5s^2 + 4s + K)\theta_L(s) + (Ms^2 + s)2X(s) = T_{eq}(s)$ .

But,  $\theta_L(s) = \frac{X(s)}{r} = \frac{X(s)}{2}$  and  $T_{eq}(s) = 2T(s)$ . Substituting these quantities in the equation

above yields  $((5 + 4M)s^2 + 8s + K)\frac{X(s)}{4} = T(s)$ . Thus, the transfer function is

$$\frac{X(s)}{T(s)} = \frac{4/(5 + 4M)}{s^2 + \frac{8}{(5 + 4M)}s + \frac{K}{(5 + 4M)}} \text{ . Now, } T_s = 15 = \frac{4}{\text{Re}} = \frac{4}{\frac{8}{2(5 + 4M)}} = (5 + 4M) \text{ .}$$

Hence,  $M = 5/2$ . For 10% overshoot,  $\zeta = 0.5912$  from Eq. (4.39). Hence,



$$2\zeta\omega_n = \frac{8}{(5+4M)} = 0.5333. \text{ Solving for } \omega_n \text{ yields } \omega_n = 0.4510. \text{ But,}$$

$$\omega_n = \sqrt{\frac{K}{(5+4M)}} = \sqrt{\frac{K}{15}} = 0.4510. \text{ Thus, } K = 3.051.$$

76.

The transfer function for the capacitor voltage is  $\frac{V_C(s)}{V(s)} = \frac{\frac{1}{Cs}}{R+Ls+\frac{1}{Cs}} = \frac{10^6}{s^2+Rs+10^6}.$

For 20% overshoot,  $\zeta = \frac{-\ln(\frac{\%OS}{100})}{\sqrt{\pi^2 + \ln^2(\frac{\%OS}{100})}} = 0.456.$  Therefore,  $2\zeta\omega_n = R = 2(0.456)(10^3) =$

912Ω.

77.

Solving for the capacitor voltage using voltage division,  $V_C(s) = V_i(s) \frac{1/(CS)}{R+LS+\frac{1}{CS}}.$  Thus, the

transfer function is  $\frac{V_C(s)}{V_i(s)} = \frac{1/(LC)}{s^2 + \frac{R}{L}s + \frac{1}{LC}}.$  Since  $T_s = \frac{4}{|\text{Re}|} = 10^{-3}, |\text{Re}| = \frac{R}{2L} = 4000.$  Thus

$R = 8 \text{ K}\Omega.$  Also, since 20% overshoot implies a damping ratio of 0.46 and  $2\zeta\omega_n = 8000, \omega_n = 8695.65 = \frac{1}{\sqrt{LC}}.$  Hence,  $C = 0.013 \mu\text{F}.$

78.

Using voltage division the transfer function is,

$$\frac{V_C(s)}{V_i(s)} = \frac{\frac{1}{Cs}}{R+Ls+\frac{1}{Cs}} = \frac{\frac{1}{LC}}{s^2 + \frac{R}{L}s + \frac{1}{LC}}$$

Also,  $T_s = 7 \times 10^{-3} = \frac{4}{\text{Re}} = \frac{4}{\frac{R}{2L}} = \frac{8L}{R}.$  Thus,  $\frac{R}{L} = 1143.$  Using Eq. (4.39) with 15% overshoot,  $\zeta$

$= 0.5169.$  But,  $2\zeta\omega_n = R/L.$  Thus,  $\omega_n = 1105.63 = \sqrt{\frac{1}{LC}} = \sqrt{\frac{1}{L(10^{-5})}}.$  Therefore,  $L = 81.8 \text{ mH}$

and  $R = 98.5 \Omega.$

79.

For the circuit shown below

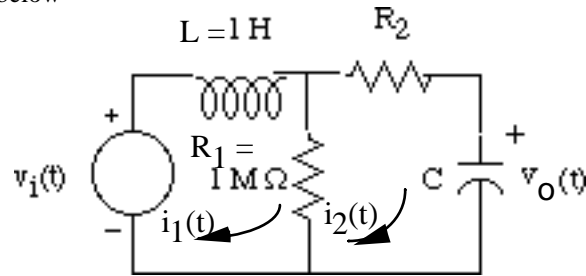

write the loop equations as

$$\begin{aligned}(R_1 + Ls)I_1(s) - R_1 I_2(s) &= V_i(s) \\ -R_1 I_1(s) + \left(R_1 + R_2 + \frac{1}{Cs}\right)I_2(s) &= 0\end{aligned}$$

Solving for  $I_2(s)$ 

$$I_2(s) = \frac{\begin{vmatrix} (R_1 + Ls) & V_i(s) \\ -R_1 & 0 \end{vmatrix}}{\begin{vmatrix} (R_1 + Ls) & -R_1 \\ -R_1 & R_1 + R_2 + \frac{1}{Cs} \end{vmatrix}}$$

But,  $V_o(s) = \frac{1}{Cs} I_2(s)$ . Thus,

$$\frac{V_o(s)}{V_i(s)} = \frac{R_1}{(R_2 + R_1)C L s^2 + (C R_2 R_1 + L)s + R_1}$$

Substituting component values,

$$\frac{V_o(s)}{V_i(s)} = 1000000 \frac{1}{(R_2 + 1000000)C} \frac{1}{s^2 + \frac{(1000000CR_2 + 1)}{(R_2 + 1000000)C}s + 1000000 \frac{1}{(R_2 + 1000000)C}}$$

For 8% overshoot,  $\zeta = 0.6266$ . For  $T_s = 0.001$ ,  $\zeta\omega_n = \frac{4}{0.001} = 4000$ . Hence,  $\omega_n = 6383.66$ . Thus,

$$1000000 \frac{1}{(R_2 + 1000000)C} = 6383.66^2$$

or,

$$C = 0.0245 \frac{1}{R_2 + 1000000} \quad (1)$$

Also,

$$\frac{1000000 C R_2 + 1}{(R_2 + 1000000) C} = 8000 \quad (2)$$

Solving (1) and (2) simultaneously,  $R_2 = 8023 \Omega$ , and  $C = 2.4305 \times 10^{-2} \mu\text{F}$ .

80.

$$\begin{aligned} s\mathbf{I} - \mathbf{A} &= \begin{bmatrix} s & 0 \\ 0 & s \end{bmatrix} - \begin{bmatrix} (3.45 - 14000K_c) & -0.255 \times 10^{-9} \\ 0.499 \times 10^{11} & -3.68 \end{bmatrix} \\ &= \begin{bmatrix} s - (3.45 - 14000K_c) & 0.255 \times 10^{-9} \\ -0.499 \times 10^{11} & s + 3.68 \end{bmatrix} \\ |s\mathbf{I} - \mathbf{A}| &= s^2 + (0.23 + 0.14 \times 10^5 K_c)s + (51520K_c + 0.0285) \\ (2\zeta\omega_n)^2 &= [2 * 0.9]^2 * (51520K_c + 0.0285) = (0.23 + 0.14 \times 10^5 K_c)^2 \end{aligned}$$

or

$$K_c^2 - 8.187 \times 10^{-4} K_c - 2.0122 \times 10^{-10} = 0$$

Solving for  $K_c$ ,

$$K_c = 8.189 \times 10^{-4}$$

81.

a. The transfer function from Chapter 2 is,

$$\frac{Y_h(s) - Y_{cat}(s)}{F_{up}(s)} = \frac{0.7883(s + 53.85)}{(s^2 + 15.47s + 9283)(s^2 + 8.119s + 376.3)}$$

The dominant poles come from  $s^2 + 8.119s + 376.3$ . Using this polynomial,

$2\zeta\omega_n = 8.119$ , and  $\omega_n^2 = 376.3$ . Thus,  $\omega_n = 19.4$  and  $\zeta = 0.209$ . Using Eq. (4.38), %OS =

51.05%. Also,  $T_s = \frac{4}{\zeta\omega_n} = 0.985$  s, and  $T_p = \frac{\pi}{\omega_n\sqrt{1-\zeta^2}} = 0.166$  s. To find rise time, use

Figure 4.16. Thus,  $\omega_n T_r = 1.2136$  or  $T_r = 0.0626$  s.

b. The other poles have a real part of  $15.47/2 = 7.735$ . Dominant poles have a real part of  $8.119/2 = 4.06$ . Thus,  $7.735/4.06 = 1.91$ . This is not at least 5 times.

c.

**Program:**

```
syms s
numg=0.7883*(s+53.85);
deng=(s^2+15.47*s+9283)*(s^2+8.119*s+376.3);
'G(s) transfer function'
G=vpa(numg/deng,3);
pretty(G)
numg=sym2poly(numg);
deng=sym2poly(deng);
G=tf(numg,deng)
step(G)
```

**Computer response:**

ans =  
G(s) transfer function

$$\frac{.788 s + 42.4}{(s^2 + 15.5 s + 9280.) (s^2 + 8.12 s + 376.)}$$

Transfer function:

$$\frac{0.7883 s + 42.45}{s^4 + 23.59 s^3 + 9785 s^2 + 8.119e004 s + 3.493e006}$$

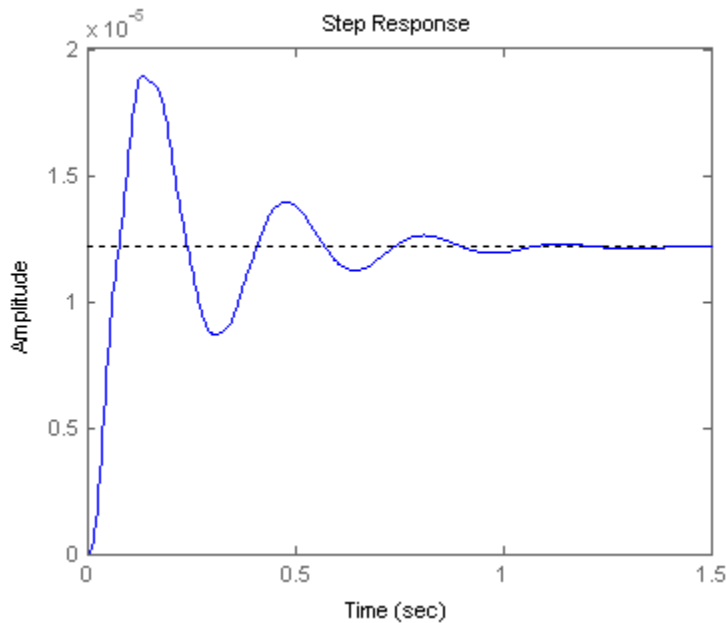

The time response shows 58 percent overshoot,  $T_s = 0.86$  s,  $T_p = 0.13$  s,  $T_r = 0.05$  s.

82.

a. In Problem 3.30 we had

$$\begin{bmatrix} \dot{T} \\ \dot{T}^* \\ \dot{v} \end{bmatrix} = \begin{bmatrix} -(d + \beta v_0) & 0 & -\beta T_0 \\ \beta v_0 & -\mu & \beta T_0 \\ 0 & k & -c \end{bmatrix} \begin{bmatrix} T \\ T^* \\ v \end{bmatrix} + \begin{bmatrix} \beta T_0 v_0 & 0 \\ -\beta T_0 v_0 & 0 \\ 0 & -k T_0^* \end{bmatrix} \begin{bmatrix} u_1 \\ u_2 \end{bmatrix}$$

$$y = \begin{bmatrix} 0 & 0 & 1 \end{bmatrix} \begin{bmatrix} T \\ T^* \\ v \end{bmatrix}$$

When  $u_2 = 0$  the equations are equivalent to

$$\begin{bmatrix} \dot{T} \\ \dot{T}^* \\ \dot{v} \end{bmatrix} = \begin{bmatrix} -(d + \beta v_0) & 0 & -\beta T_0 \\ \beta v_0 & -\mu & \beta T_0 \\ 0 & k & -c \end{bmatrix} \begin{bmatrix} T \\ T^* \\ v \end{bmatrix} + \begin{bmatrix} \beta T_0 v_0 \\ -\beta T_0 v_0 \\ 0 \end{bmatrix} u_1$$

$$y = \begin{bmatrix} 0 & 0 & 1 \end{bmatrix} \begin{bmatrix} T \\ T^* \\ v \end{bmatrix}$$

Substituting parameter values one gets

$$\begin{bmatrix} \dot{T} \\ \dot{T}^* \\ \dot{v} \end{bmatrix} = \begin{bmatrix} -0.04167 & 0 & -0.0058 \\ 0.0217 & -0.24 & 0.0058 \\ 0 & 100 & -2.4 \end{bmatrix} \begin{bmatrix} T \\ T^* \\ v \end{bmatrix} + \begin{bmatrix} 5.2 \\ -5.2 \\ 0 \end{bmatrix} u_1$$

$$y = \begin{bmatrix} 0 & 0 & 1 \end{bmatrix} \begin{bmatrix} T \\ T^* \\ v \end{bmatrix}$$

**b.**

$$(s\mathbf{I} - \mathbf{A})^{-1} = \begin{bmatrix} s + 0.04167 & 0 & 0.0058 \\ -0.0217 & s + 0.24 & -0.0058 \\ 0 & -100 & s + 2.4 \end{bmatrix}^{-1} = \frac{\text{Adj}(s\mathbf{I} - \mathbf{A})}{\det(s\mathbf{I} - \mathbf{A})}$$

$$\begin{aligned} \det(s\mathbf{I} - \mathbf{A}) &= (s + 0.04167) \begin{vmatrix} s + 0.24 & -0.0058 \\ -100 & s + 2.4 \end{vmatrix} + 0.0058 \begin{vmatrix} -0.0217 & s + 0.24 \\ 0 & -100 \end{vmatrix} \\ &= (s + 0.04167)[(s + 0.24)(s + 2.4) - 0.58] + (0.0058)(2.17) \\ &= s^3 + 2.6817s^2 + 0.11s + 0.0126 \\ &= (s + 2.6419)(s^2 + 0.0398s + 0.0048) \end{aligned}$$

To obtain the adjoint matrix we calculate the cofactors:

$$C_{11} = \begin{vmatrix} s + 0.24 & -0.0058 \\ -100 & s + 2.4 \end{vmatrix} = s(s + 2.64)$$

$$C_{12} = \begin{vmatrix} -0.0217 & -0.0058 \\ 0 & s + 2.4 \end{vmatrix} = -0.0217(s + 2.4)$$

$$C_{13} = \begin{vmatrix} -0.0217 & s + 0.24 \\ 0 & -100 \end{vmatrix} = 2.17$$

$$C_{21} = \begin{vmatrix} 0 & 0.0058 \\ -100 & s + 2.4 \end{vmatrix} = 0.58$$

$$C_{22} = \begin{vmatrix} s + 0.04167 & 0.0058 \\ 0 & s + 2.4 \end{vmatrix} = (s + 0.04167)(s + 2.4)$$

$$C_{23} = \begin{vmatrix} s + 0.04167 & 0 \\ 0 & -100 \end{vmatrix} = -100(s + 0.04167)$$

$$C_{31} = \begin{vmatrix} 0 & 0.0058 \\ s + 0.24 & -0.0058 \end{vmatrix} = -0.0058(s + 0.24)$$

$$C_{32} = \begin{vmatrix} s + 0.04167 & 0.0058 \\ -0.0217 & s + 2.4 \end{vmatrix} = s^2 + 2.4117s + 0.1001$$

$$C_{33} = \begin{vmatrix} s + 0.04167 & 0 \\ -0.0217 & s + 0.24 \end{vmatrix} = s^2 + 0.2817s + 0.01$$

Then we have

$$\text{Adj}(s\mathbf{I} - \mathbf{A}) = \begin{bmatrix} s(s + 2.64) & -0.58 & -0.0058(s + 0.24) \\ 0.0217(s + 2.4) & (s + 0.04167)(s + 2.4) & -(s^2 + 2.4417s + 0.1101) \\ 2.17 & 100(s + 0.04167) & s^2 + 0.2817s + 0.01 \end{bmatrix}$$

Finally

$$\begin{aligned} \frac{Y}{U_1}(s) &= \mathbf{C}(s\mathbf{I} - \mathbf{A})^{-1}\mathbf{B} = \frac{\begin{bmatrix} 2.17 & 100(s + 0.04167) & s^2 + 0.2817s + 0.01 \end{bmatrix}}{(s + 2.6419)(s^2 + 0.0398s + 0.0048)} \begin{bmatrix} 5.2 \\ -5.2 \\ 0 \end{bmatrix} \\ &= \frac{-520s - 10.3844}{(s + 2.6419)(s^2 + 0.0398s + 0.0048)} = -520 \frac{s + 0.02}{(s + 2.6419)(s^2 + 0.0398s + 0.0048)} \end{aligned}$$

c. 100% effectiveness means that  $u_1 = 1$  or  $U_1(s) = \frac{1}{s}$ , so by the final value theorem

$$y(\infty) = \lim_{s \rightarrow 0} sY(s) = -\lim_{s \rightarrow 0} s \frac{520(s + 0.02)}{(s + 2.6419)(s^2 + 0.0398s + 0.0048)} \frac{1}{s} = -820.1168$$

(virus copies per mL of plasma)

The closest poles to the imaginary axis are  $-0.0199 \pm j0.0661$  so the approximate settling time

$$\text{will be } T_s \approx \frac{4}{0.0199} = 210 \text{ days.}$$

83.

a.

Substituting  $\Delta F(s) = \frac{2650}{s}$  into the transfer function and solving for  $\Delta V(s)$  gives:

$$\Delta V(s) = \frac{\Delta F(s)}{1908 \cdot s} = \frac{2650}{s(1908 \cdot s + 10)} = \frac{A}{s} + \frac{B}{(1908 \cdot s + 10)}$$

$$\text{Here: } A = \left. \frac{2650}{(1908 \cdot s + 10)} \right|_{s=0} = 265 \text{ and } B = \left. \frac{2650}{s} \right|_{s=-1/190.8} = -505,620$$

Substituting we have:

$$\Delta V(s) = \frac{265}{s} - \frac{505620}{(1908 \cdot s + 10)} = 265 \left( \frac{1}{s} - \frac{1}{(s + 5.24 \times 10^{-3})} \right)$$

Taking the inverse Laplace transform, we have:

$$\Delta v(t) = 265(1 - e^{-5.24 \times 10^{-3} t}) \cdot u(t), \text{ in m/s}$$

**b.**

```
>> s=tf('s');
>> G=1/(1908*s+10);
>> t=0:0.1:1000;
>> y1=2650*step(G,t);
>> y2=265*(1-exp(-5.24e-3.*t));
>> plot(t,y1,t,y2)
>> xlabel('sec')
>> ylabel('m/s')
```

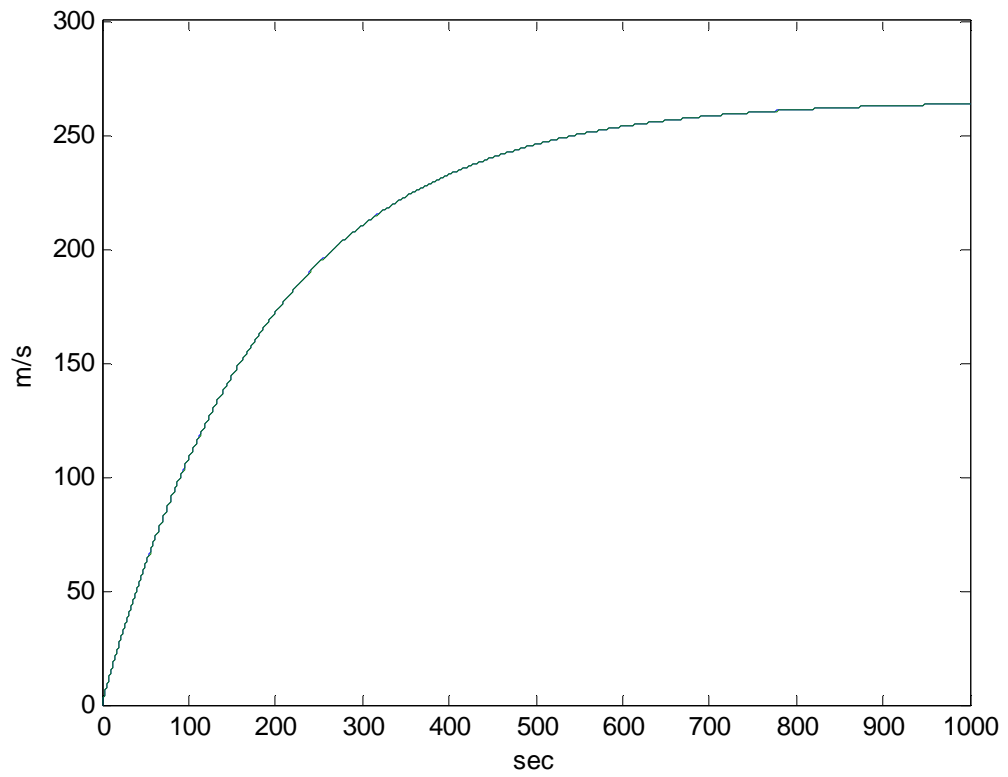

Both plots are identical.



# FIVE

## Reduction of Multiple Subsystems

### SOLUTIONS TO CASE STUDIES CHALLENGES

#### Antenna Control: Designing a Closed-Loop Response

a. Drawing the block diagram of the system:

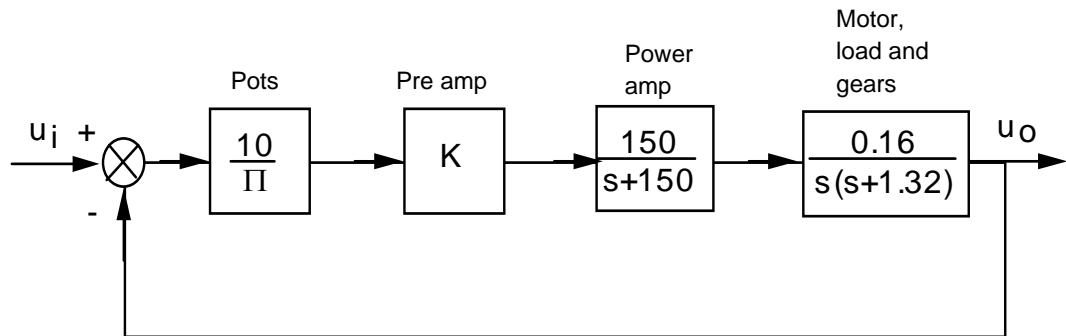

$$\text{Thus, } T(s) = \frac{76.39K}{s^3 + 151.32s^2 + 198s + 76.39K}$$

b. Drawing the signal flow-diagram for each subsystem and then interconnecting them yields:

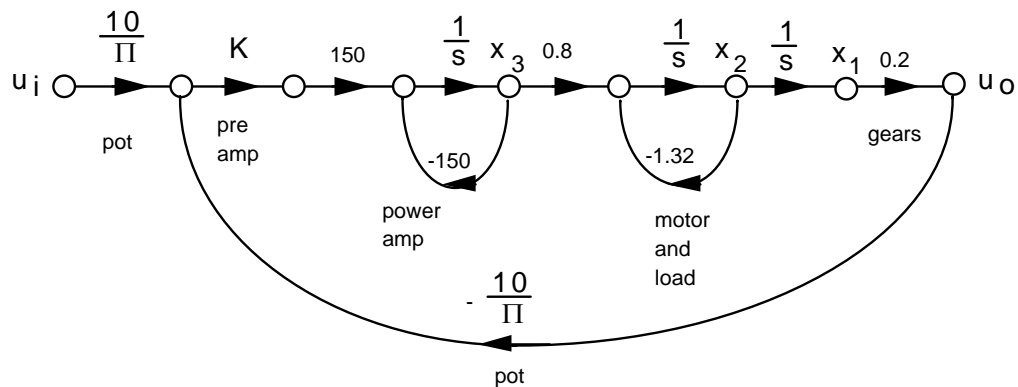

$$\begin{aligned} \dot{x}_1 &= x_2 \\ \dot{x}_2 &= -1.32x_2 + 0.8x_3 \\ \dot{x}_3 &= -150x_3 + 150K\left(\frac{10}{\pi}(q_i - 0.2x_1)\right) = -95.49Kx_1 - 150x_3 + 477.46Kq_i \\ \theta_o &= 0.2x_1 \end{aligned}$$

In vector-matrix notation,

$$\dot{\mathbf{x}} = \begin{bmatrix} 0 & 1 & 0 \\ 0 & -1.32 & 0.8 \\ -95.49K & 0 & -150 \end{bmatrix} \mathbf{x} + \begin{bmatrix} 0 \\ 0 \\ 477.46K \end{bmatrix} \theta_i$$

$$\theta_o = [0.2 \quad 0 \quad 0] \mathbf{x}$$

$$\text{c. } T_1 = \left(\frac{10}{\pi}\right)(K)(150)\left(\frac{1}{s}\right)(0.8)\left(\frac{1}{s}\right)\left(\frac{1}{s}\right)(0.2) = \frac{76.39}{s^3}$$

$$G_{L1} = \frac{-150}{s}; G_{L2} = \frac{-1.32}{s}; G_{L3} = (K)(150)\left(\frac{1}{s}\right)(0.8)\left(\frac{1}{s}\right)\left(\frac{1}{s}\right)(0.2)\left(\frac{-10}{\pi}\right) = \frac{-76.39K}{s^3}$$

Nontouching loops:

$$G_{L1}G_{L2} = \frac{198}{s^2}$$

$$\Delta = 1 - [G_{L1} + G_{L2} + G_{L3}] + [G_{L1}G_{L2}] = 1 + \frac{150}{s} + \frac{1.32}{s} + \frac{76.39K}{s^3} + \frac{198}{s^2}$$

$$\Delta_1 = 1$$

$$T(s) = \frac{T_1\Delta_1}{\Delta} = \frac{76.39K}{s^3 + 151.32s^2 + 198s + 76.39K}$$

$$\text{d. The equivalent forward path transfer function is } G(s) = \frac{\frac{10}{\pi} 0.16K}{s(s+1.32)} \cdot$$

Therefore,

$$T(s) = \frac{2.55}{s^2 + 1.32s + 2.55}$$

The poles are located at  $-0.66 \pm j1.454$ .  $\omega_n = \sqrt{2.55} = 1.597$  rad/s;  $2\zeta\omega_n = 1.32$ , therefore,  $\zeta = 0.413$ .

$$\%OS = e^{-\zeta\pi / \sqrt{1-\zeta^2}} \times 100 = 24\%; T_s = \frac{4}{\zeta\omega_n} = \frac{4}{0.66} = 6.06 \text{ seconds}; T_p = \frac{\pi}{\omega_n\sqrt{1-\zeta^2}} = \frac{\pi}{1.454} =$$

2.16 seconds; Using Figure 4.16, the normalized rise time is 1.486. Dividing by the natural frequency,  $T_r = \frac{1.486}{\sqrt{2.55}} = 0.93$  seconds.

e.

$$C(s) = \frac{2.55}{s(s^2 + 1.32s + 2.55)}$$

$$C(s) = \frac{1}{s} - \frac{1}{25} \frac{25s + 33}{s^2 + 1.32s + 2.55}$$

$$C(s) = \frac{1}{s} - \frac{1}{25} \frac{25(s + 0.66) + 11.347\sqrt{2.1144}}{(s + 0.66)^2 + \sqrt{2.1144}^2}$$

$$c(t) = 1 - e^{-0.66t} (\cos[1.454t] + 0.454 \sin[1.454t])$$

f. Since  $G(s) = \frac{0.51K}{s(s+1.32)}$ ,  $T(s) = \frac{0.51K}{s^2+1.32s+0.51K}$ . Also,  $\zeta = \frac{-\ln(\frac{\%OS}{100})}{\sqrt{\pi^2 + \ln^2(\frac{\%OS}{100})}} = 0.517$  for 15% overshoot;  $\omega_n = \sqrt{0.51K}$ ; and  $2\zeta\omega_n = 1.32$ . Therefore,  $\omega_n = \frac{1.32}{2\zeta} = \frac{1.32}{2(0.5147)} = 1.277 = \sqrt{0.51K}$ .

Solving for K, K=3.2.

### UFSS Vehicle: Pitch-Angle Control Representation

a. Use the observer canonical form for the vehicle dynamics so that the output yaw rate is a state variable.

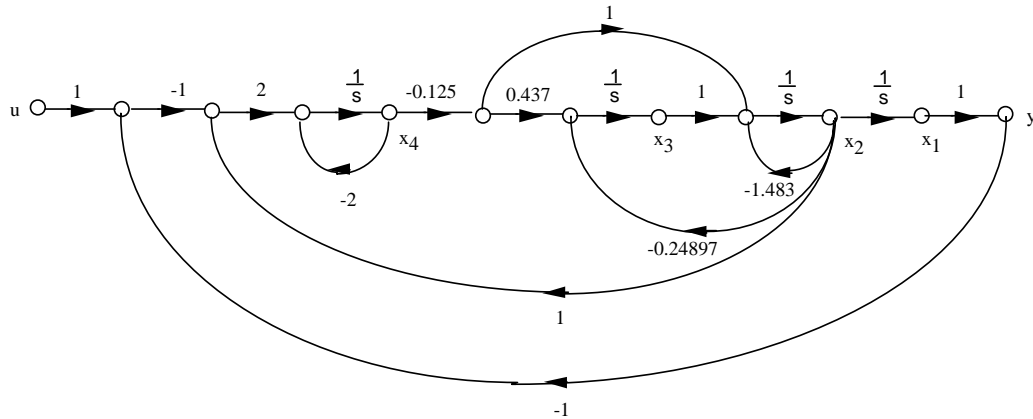

b. Using the signal flow graph to write the state equations:

$$\begin{aligned}\dot{x}_1 &= x_2 \\ \dot{x}_2 &= -1.483x_2 + x_3 - 0.125x_4 \\ \dot{x}_3 &= -0.24897x_2 - (0.125 * 0.437)x_4 \\ \dot{x}_4 &= 2x_1 + 2x_2 - 2x_4 - 2u\end{aligned}$$

In vector-matrix form:

$$\dot{\mathbf{x}} = \begin{bmatrix} 0 & 1 & 0 & 0 \\ 0 & -1.483 & 0 & -0.125 \\ 0 & -0.24897 & 0 & -0.054625 \\ 2 & 2 & 0 & -2 \end{bmatrix} \mathbf{x} + \begin{bmatrix} 0 \\ 0 \\ 0 \\ -2 \end{bmatrix}$$

$$y = [1 \ 0 \ 0 \ 0] \mathbf{x}$$

c.

**Program:**

```
numg1=-0.25*[1 0.437];
deng1=poly([-2 -1.29 -0.193 0]);
'G(s)'
G=tf(numg1,deng1)
numh1=[-1 0];
denh1=[0 1];
'H(s)'
H=tf(numh1,denh1)
'Ge(s)'
Ge=feedback(G,H)
'T(s)'
T=feedback(-1*Ge,1)
[numt,dent]=tfdata(T,'V');
[Acc,Bcc,Ccc,Dcc]=tf2ss(numt,dent)
```

**Computer response:**

ans =

G(s)

Transfer function:

$$\frac{-0.25 s - 0.1093}{s^4 + 3.483 s^3 + 3.215 s^2 + 0.4979 s}$$

-----

ans =

H(s)

Transfer function:

$$\frac{-s}{s^4 + 3.483 s^3 + 3.215 s^2 + 0.4979 s}$$

ans =

Ge(s)

Transfer function:  

$$\frac{-0.25 s - 0.1093}{s^4 + 3.483 s^3 + 3.465 s^2 + 0.6072 s}$$

ans =

T(s)

Transfer function:  

$$\frac{0.25 s + 0.1093}{s^4 + 3.483 s^3 + 3.465 s^2 + 0.8572 s + 0.1093}$$

Acc =

$$\begin{array}{cccc} -3.4830 & -3.4650 & -0.8572 & -0.1093 \\ 1.0000 & 0 & 0 & 0 \\ 0 & 1.0000 & 0 & 0 \\ 0 & 0 & 1.0000 & 0 \end{array}$$

Bcc =

$$\begin{array}{c} 1 \\ 0 \\ 0 \\ 0 \end{array}$$

Ccc =

$$\begin{array}{cccc} 0 & 0 & 0.2500 & 0.1093 \end{array}$$

Dcc =

$$0$$

## ANSWERS TO REVIEW QUESTIONS

1. Signals, systems, summing junctions, pickoff points
2. Cascade, parallel, feedback
3. Product of individual transfer functions, sum of individual transfer functions, forward gain divided by one plus the product of the forward gain times the feedback gain
4. Equivalent forms for moving blocks across summing junctions and pickoff points
5. As K is varied from 0 to  $\infty$ , the system goes from overdamped to critically damped to underdamped. When the system is underdamped, the settling time remains constant.
6. Since the real part remains constant and the imaginary part increases, the radial distance from the origin is increasing. Thus the angle  $\theta$  is increasing. Since  $\zeta = \cos \theta$  the damping ratio is decreasing.
7. Nodes (signals), branches (systems)
8. Signals flowing into a node are added together. Signals flowing out of a node are the sum of signals flowing into a node.
9. One
10. Phase-variable form, cascaded form, parallel form, Jordan canonical form, observer canonical form

11. The Jordan canonical form and the parallel form result from a partial fraction expansion.
12. Parallel form
13. The system poles, or eigenvalues
14. The system poles including all repetitions of the repeated roots
15. Solution of the state variables are achieved through decoupled equations. i.e. the equations are solvable individually and not simultaneously.
16. State variables can be identified with physical parameters; ease of solution of some representations
17. Systems with zeros
18. State-vector transformations are the transformation of the state vector from one basis system to another. i.e. the same vector represented in another basis.
19. A vector which under a matrix transformation is collinear with the original. In other words, the length of the vector has changed, but not its angle.
20. An eigenvalue is that multiple of the original vector that is the transformed vector.
21. Resulting system matrix is diagonal.

## SOLUTIONS TO PROBLEMS

1.
  - a. Combine the inner feedback and the parallel pair.

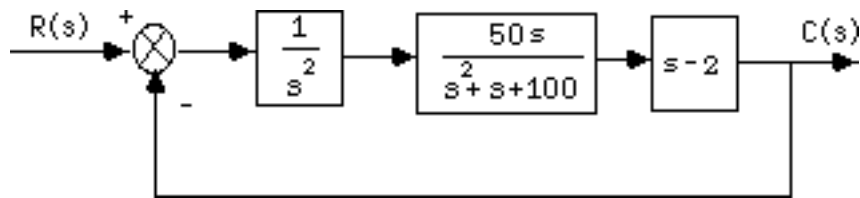

Multiply the blocks in the forward path and apply the feedback formula to get,

$$T(s) = \frac{50(s-2)}{s^3 + s^2 + 150s - 100}$$

**b.**

**Program:**

```
'G1(s)'  
G1=tf(1,[1 0 0])  
'G2(s)'  
G2=tf(50,[1 1])  
'G3(s)'  
G3=tf(2,[1 0])  
'G4(s)'  
G4=tf([1 0],1)  
'G5(s)'  
G5=2  
'Ge1(s)=G2(s)/(1+G2(s)G3(s))'  
Ge1=G2/(1+G2*G3)  
'Ge2(s)=G4(s)-G5(s)'
```

```

Ge2=G4-G5
'Ge3(s)=G1(s)Ge1(s)Ge2(s)'
Ge3=G1*Ge1*Ge2
'T(s)=Ge3(s)/(1+Ge3(s))'
T=feedback(Ge3,1);
T=minreal(T)

```

**Computer response:**

```
ans =
```

```
G1(s)
```

```
Transfer function:
```

```

  1
  ---
 s^2

```

```
ans =
```

```
G2(s)
```

```
Transfer function:
```

```

  50
  ----
 s + 1

```

```
ans =
```

```
G3(s)
```

```
Transfer function:
```

```

  2
  -
 s

```

```
ans =
```

```
G4(s)
```

```
Transfer function:
```

```
s
```

```
ans =
```

```
G5(s)
```

```
G5 =
```

```

  2

```

```
ans =
```

```
Ge1(s)=G2(s)/(1+G2(s)G3(s))
```

```
Transfer function:
```

```

      50 s^2 + 50 s
  -----
 s^3 + 2 s^2 + 101 s + 100

```

```
ans =
```

```
Ge2(s)=G4(s)-G5(s)
```

5-8 Chapter 5: Reduction of Multiple Subsystems

Transfer function:

$$s - 2$$

ans =

$$Ge3(s) = G1(s)Ge1(s)Ge2(s)$$

Transfer function:

$$\frac{50 s^3 - 50 s^2 - 100 s}{s^5 + 2 s^4 + 101 s^3 + 100 s^2}$$

ans =

$$T(s) = Ge3(s) / (1 + Ge3(s))$$

Transfer function:

$$\frac{50 s - 100}{s^3 + s^2 + 150 s - 100}$$

2.

Push  $G_1(s)$  to the left past the pickoff point.

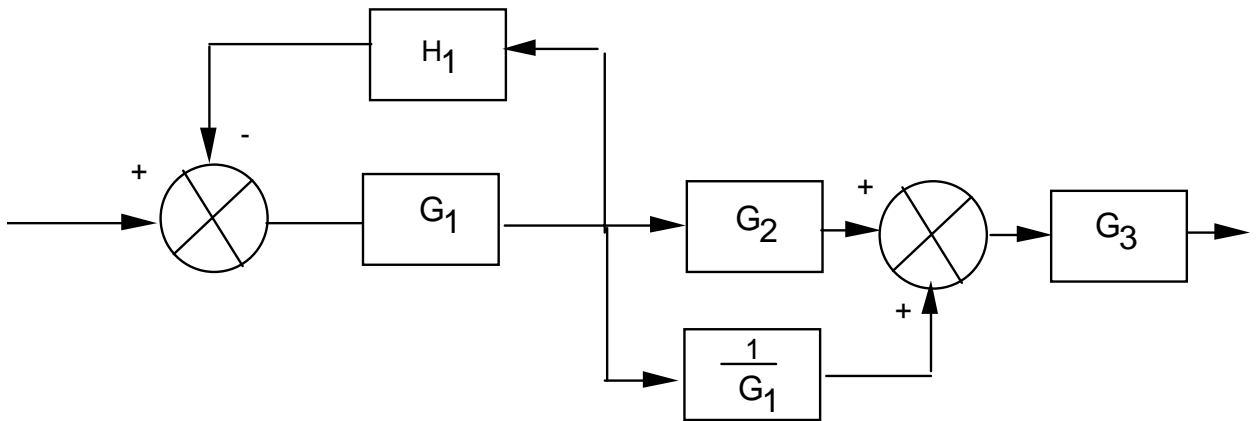

$$\text{Thus, } T(s) = \left( \frac{G_1}{1 + G_1 H_1} \right) \left( G_2 + \frac{1}{G_1} \right) G_3 = \frac{(G_1 G_2 + 1) G_3}{(1 + G_1 H_1)}$$



3. a. Split  $G_3$  and combine with  $G_2$  and  $G_4$ . Also use feedback formula on  $G_6$  loop.

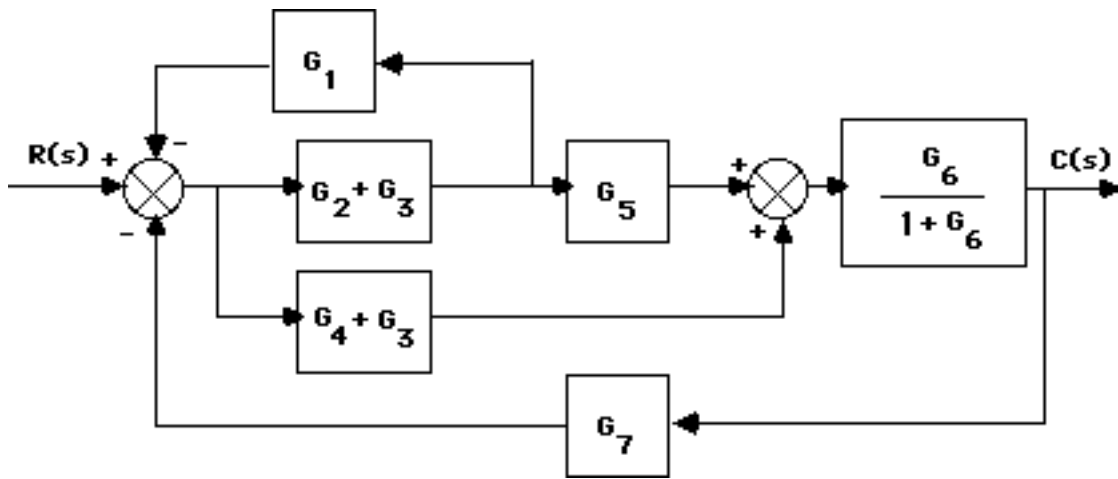

Push  $G_2 + G_3$  to the left past the pickoff point.

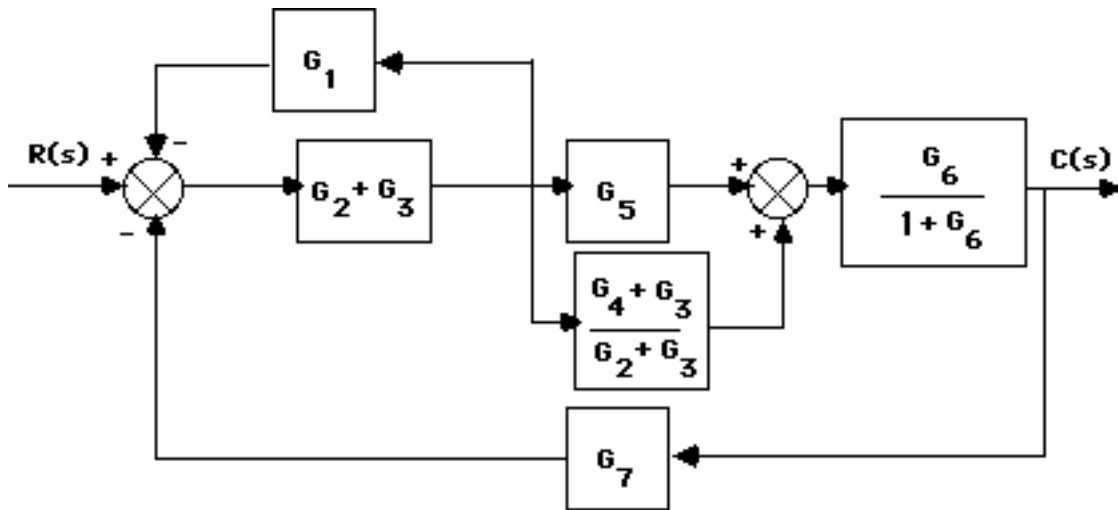

Using the feedback formula and combining parallel blocks,

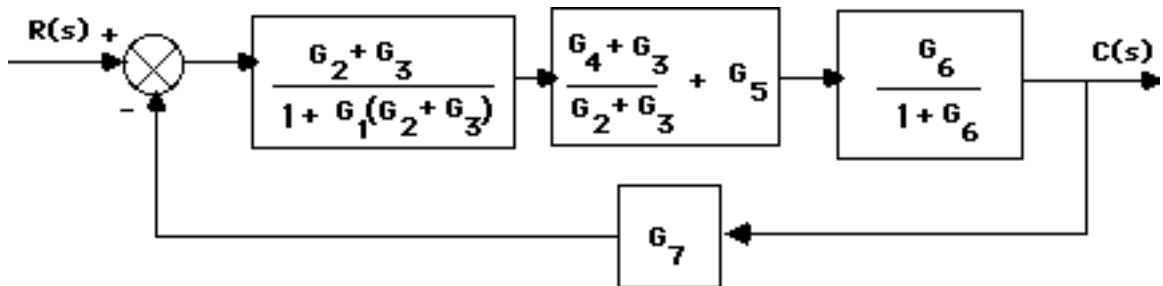

Multiplying the blocks of the forward path and applying the feedback formula,

$$T(s) = \frac{G_6 G_4 + G_6 G_3 + G_6 G_5 G_3 + G_6 G_5 G_2}{1 + G_6 + G_3 G_1 + G_2 G_1 + G_7 G_6 G_4 + G_7 G_6 G_3 + G_7 G_6 G_5 G_3 + G_7 G_6 G_5 G_2 + G_6 G_3 G_1 + G_6 G_2 G_1}$$

4. Push  $G_2(s)$  to the left past the summing junction.

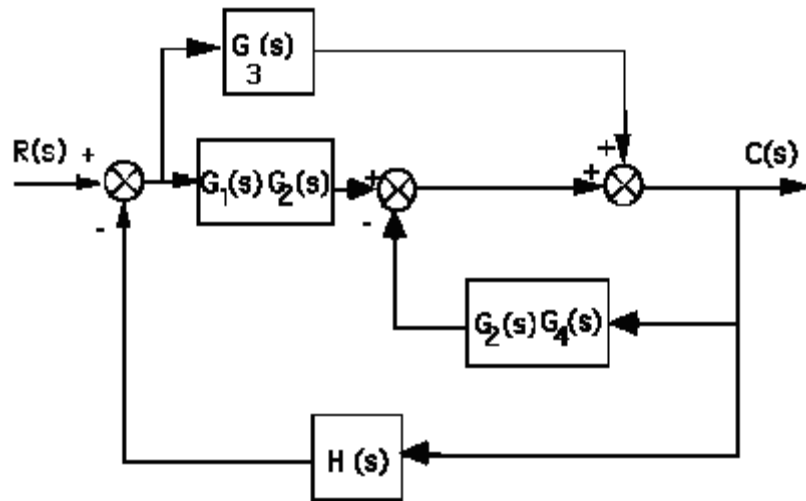

Collapse the summing junctions and add the parallel transfer functions.

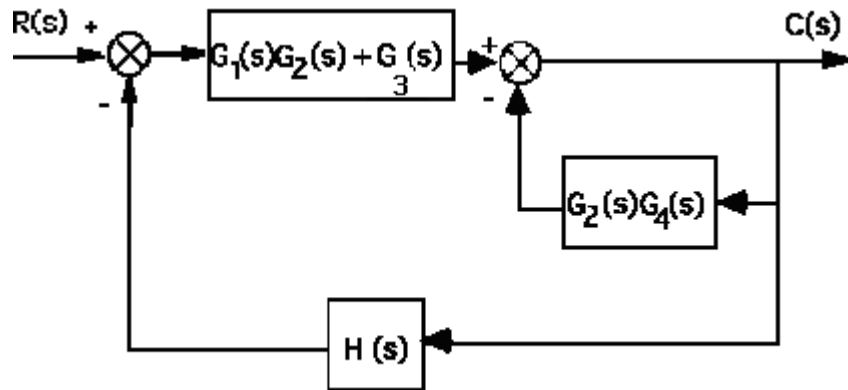

Push  $G_1(s)G_2(s) + G_3(s)$  to the right past the summing junction.

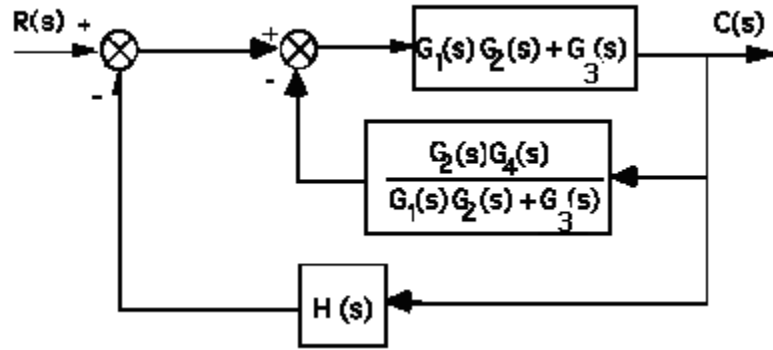

Collapse summing junctions and add feedback paths.

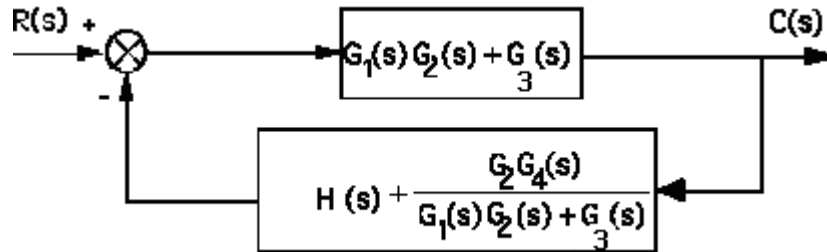

Applying the feedback formula,

$$\begin{aligned}
 T(s) &= \frac{G_3(s) + G_1(s)G_2(s)}{1 + [G_3(s) + G_1(s)G_2(s)] \left[ H + \frac{G_2(s)G_4(s)}{G_3(s) + G_1(s)G_2(s)} \right]} \\
 &= \frac{G_3(s) + G_1(s)G_2(s)}{1 + H[G_3(s) + G_1(s)G_2(s)] + G_2(s)G_4(s)}
 \end{aligned}$$

5.

- a. Push  $G_7$  to the left past the pickoff point. Add the parallel blocks,  $G_3+G_4$ .

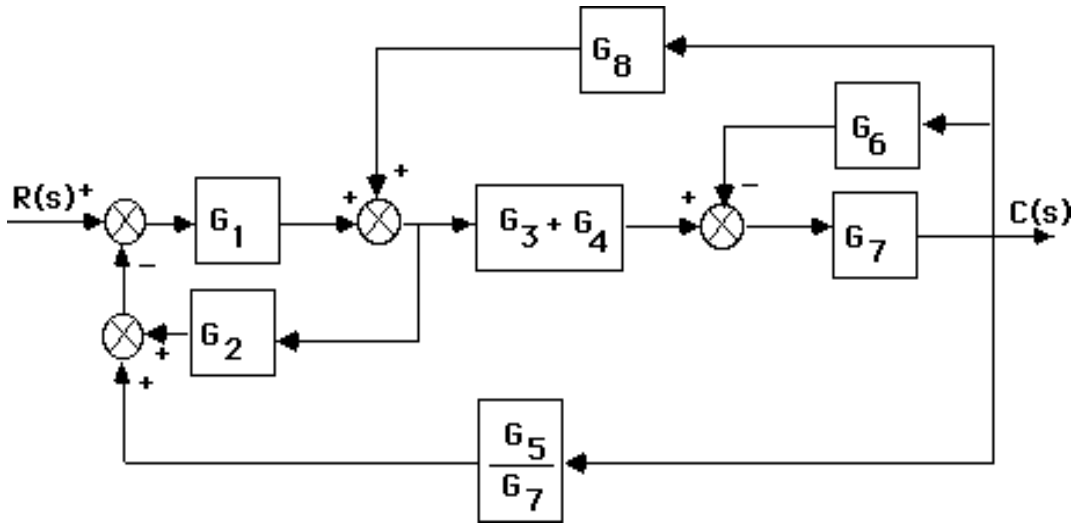

Push  $G_3+G_4$  to the right past the summing junction.

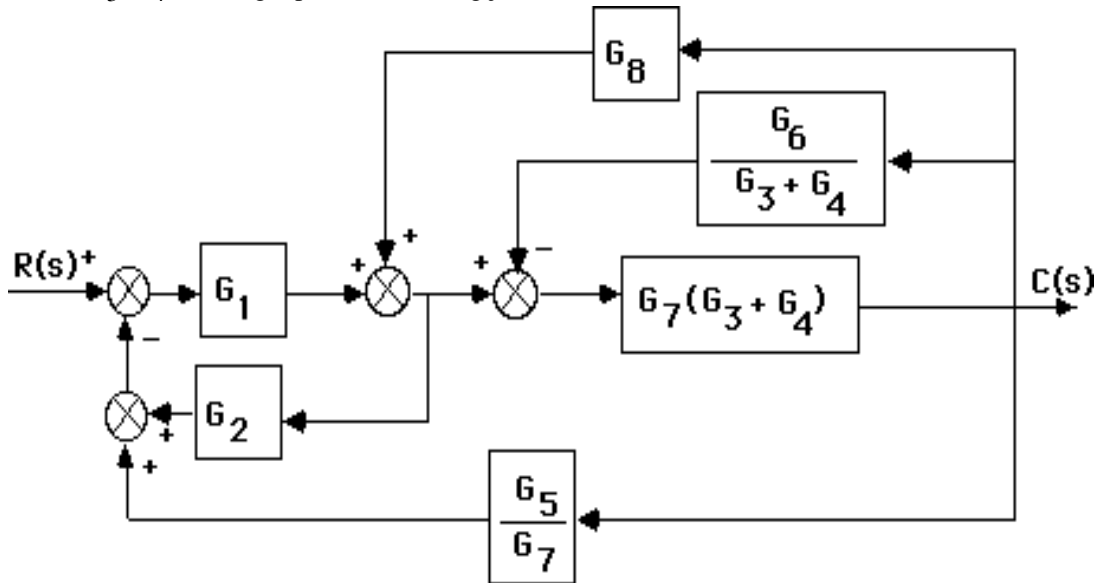

Collapse the minor loop feedback.

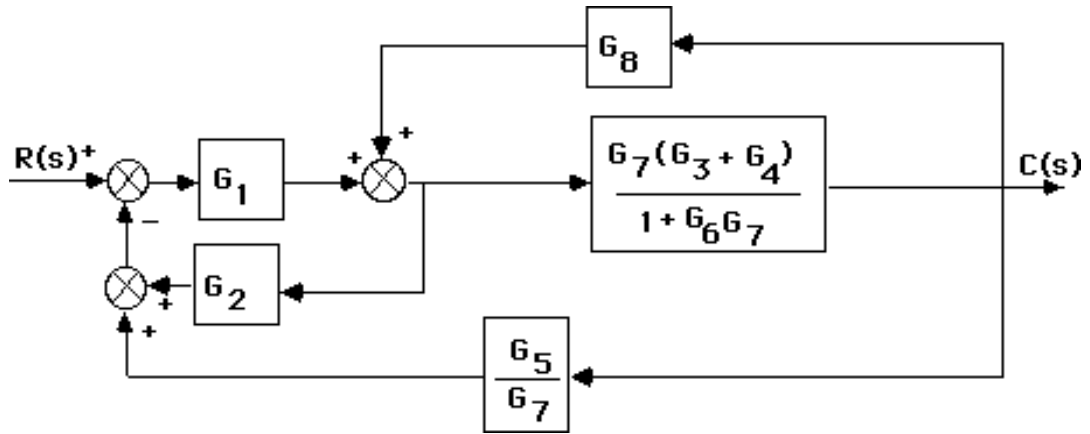

Push  $\frac{G_7(G_3+G_4)}{1+G_6G_7}$  to the left past the pickoff point.

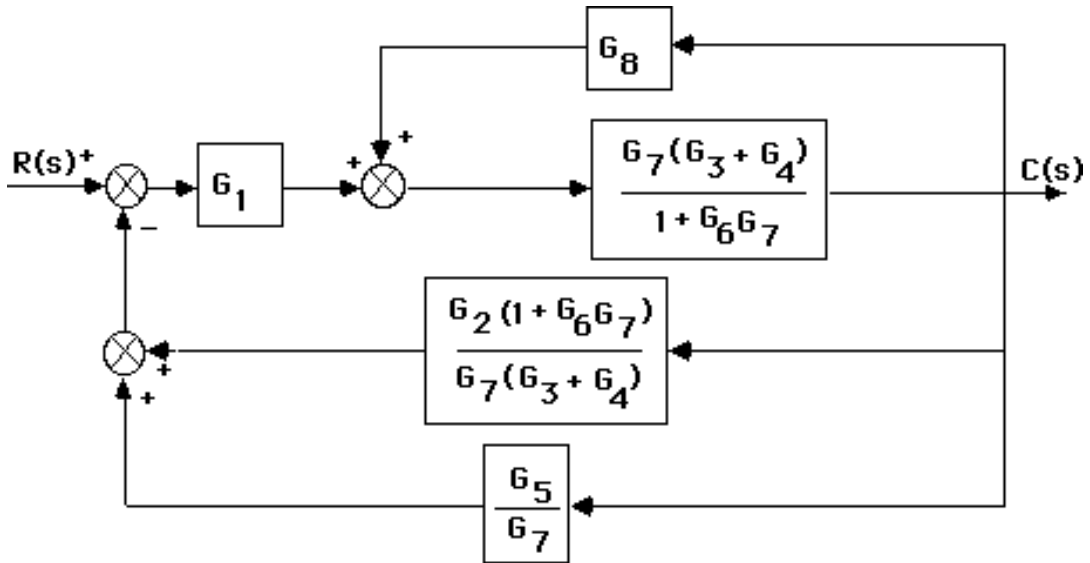

Push  $G_1$  to the right past the summing junction.

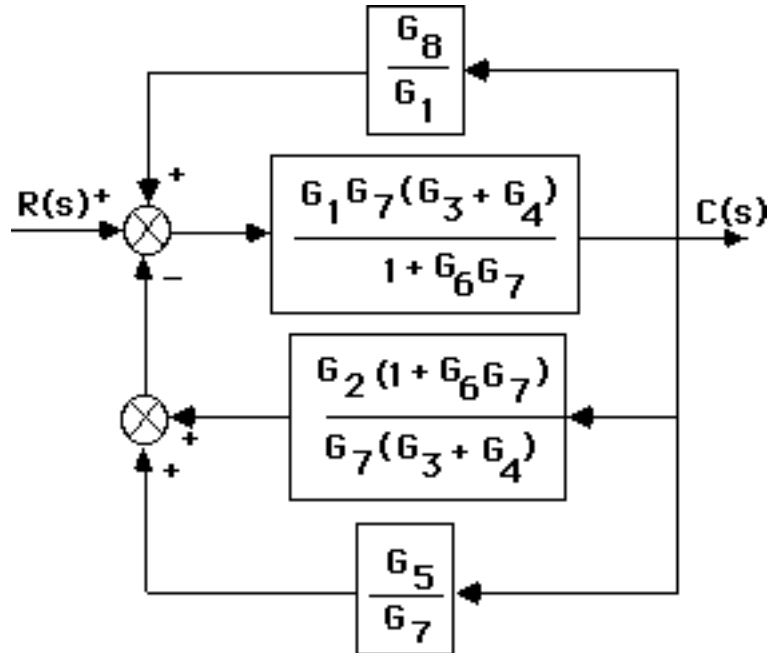

Add the parallel feedback paths to get the single negative feedback,

$$H(s) = \frac{G_5}{G_7} + \frac{G_2(1+G_6G_7)}{G_7(G_3+G_4)} - \frac{G_8}{G_1}. \text{ Thus,}$$

$$T(s) = \frac{G}{1+GH} = \frac{G_7 G_1 (G_4 + G_3)}{([G_7 G_6 + 1] G_2 G_1 + [G_4 + G_3] [G_5 G_1 - G_8 G_7]) + (G_7 G_6 + 1)}$$

b.

**Program:**

```
G1=tf([0 1],[1 7]); %G1=1/s+7 input transducer
G2=tf([0 0 1],[1 2 3]); %G2=1/s^2+2s+3
G3=tf([0 1],[1 4]); %G3=1/s+4
G4=tf([0 1],[1 0]); %G4=1/s
G5=tf([0 5],[1 7]); %G5=5/s+7
G6=tf([0 0 1],[1 5 10]); %G6=1/s^2+5s+10
G7=tf([0 3],[1 2]); %G7=3/s+2
G8=tf([0 1],[1 6]); %G8=1/s+6
G9=tf([1],[1]); %Add G9=1 transducer at the input
T1=append(G1,G2,G3,G4,G5,G6,G7,G8,G9);
Q=[1 -2 -5 9
2 1 8 0
3 1 8 0
4 1 8 0
5 3 4 -6
6 7 0 0
7 3 4 -6
8 7 0 0];
inputs=9;
outputs=7;
Ts=connect(T1,Q,inputs,outputs);
T=tf(Ts)
```

**Computer response:**

Transfer function:

$$6 s^7 + 132 s^6 + 1176 s^5 + 5640 s^4 + 1.624e004 s^3 + 2.857e004 s^2 + 2.988e004 s + 1.512e004$$

$$s^{10} + 33 s^9 + 466 s^8 + 3720 s^7 + 1.867e004 s^6 + 6.182e004 s^5 + 1.369e005 s^4 + 1.981e005 s^3 + 1.729e005 s^2 + 6.737e004 s - 1.044e004$$

6.

Combine  $G_6$  and  $G_7$  yielding  $G_6G_7$ . Add  $G_4$  and obtain the following diagram:

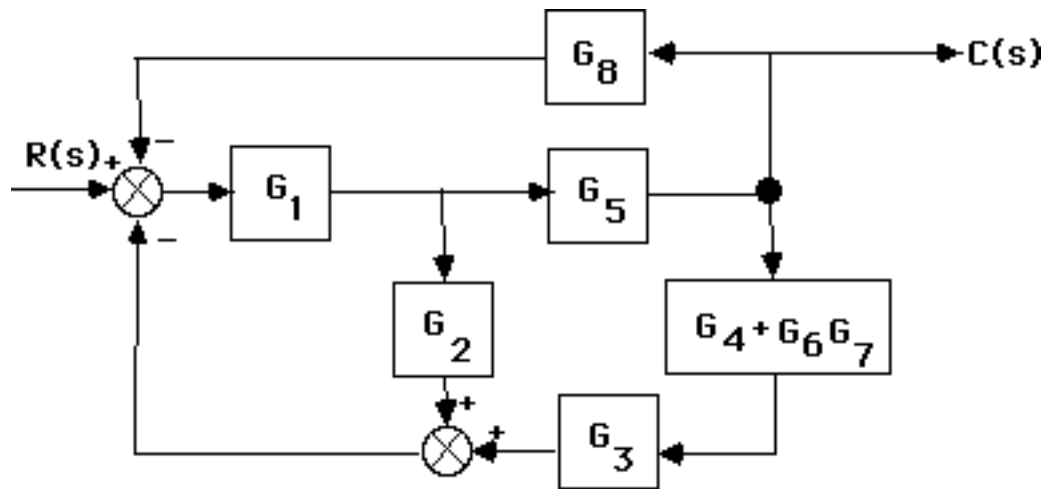

Next combine  $G_3$  and  $G_4+G_6G_7$ .

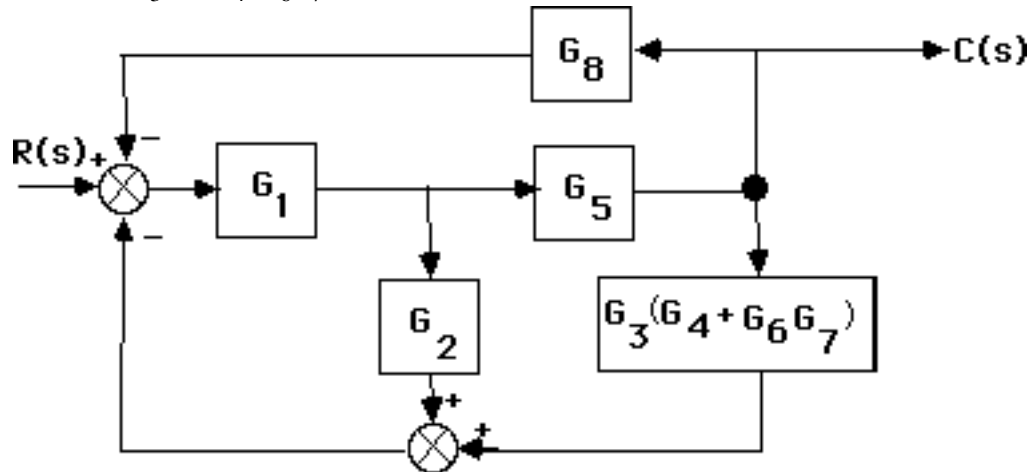

Push  $G_5$  to the left past the pickoff point.

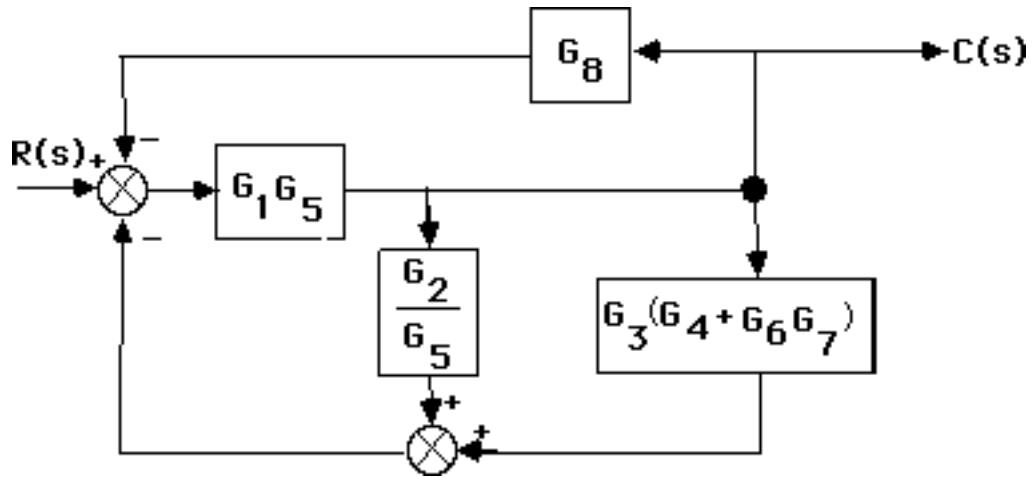

Notice that the feedback is in parallel form. Thus the equivalent feedback,  $H_{eq}(s) = \frac{G_2}{G_5} + G_3(G_4+G_6G_7) + G_8$ . Since the forward path transfer function is  $G(s) = G_{eq}(s) = G_1G_5$ , the closed-loop transfer function is

$$T(s) = \frac{G_{eq}(s)}{1 + G_{eq}(s)H_{eq}(s)}$$

Hence,

$$T(s) = \frac{G_5 G_1}{1 + G_1 (G_8 G_5 + G_7 G_6 G_5 G_3 + G_5 G_4 G_3 + G_2)}$$

7.

Push  $2s$  to the right past the pickoff point.

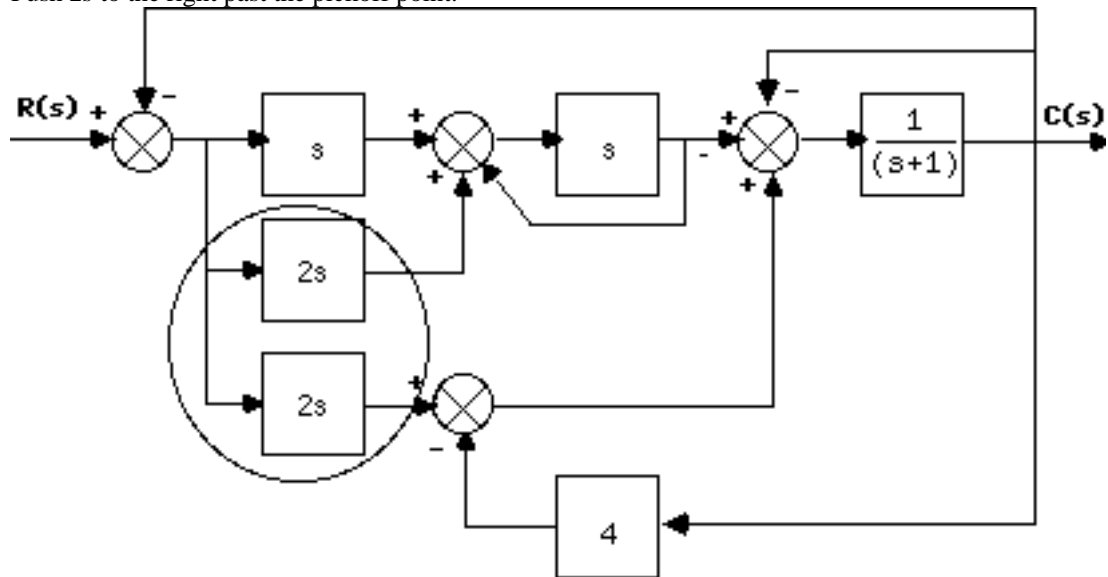



Combine summing junctions.

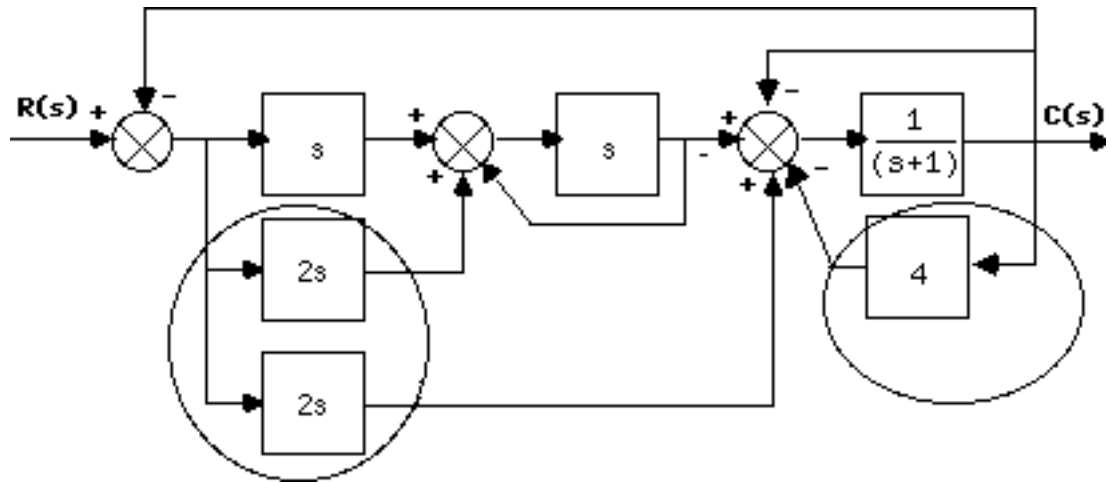

Combine parallel  $2s$  and  $s$ . Apply feedback formula to unity feedback with  $G(s) = s$ .

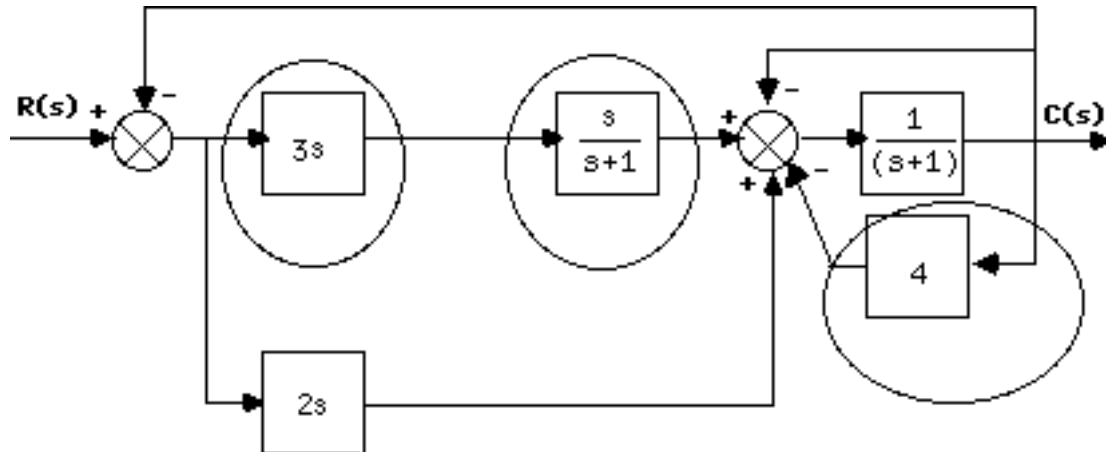

Combine cascade pair and add feedback around  $1/(s+1)$ .

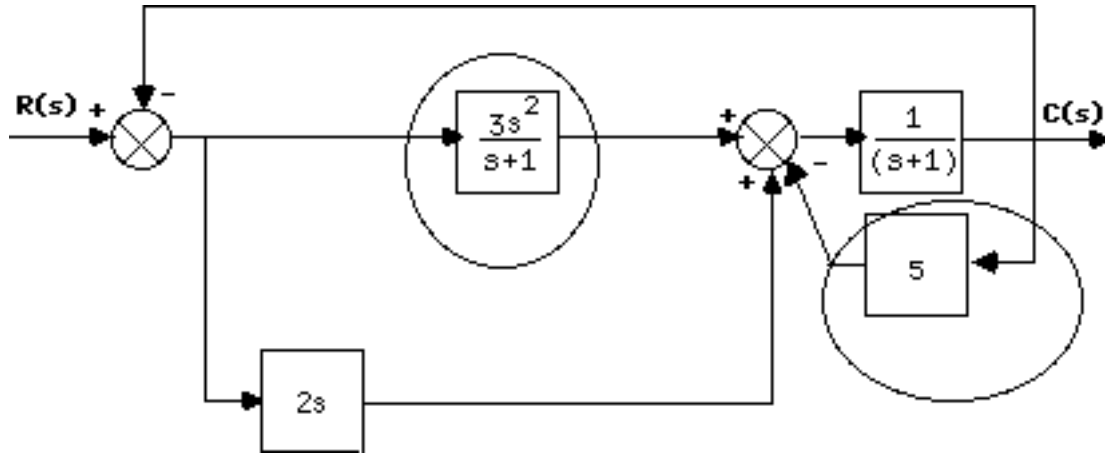

Combine parallel pair and feedback in forward path.

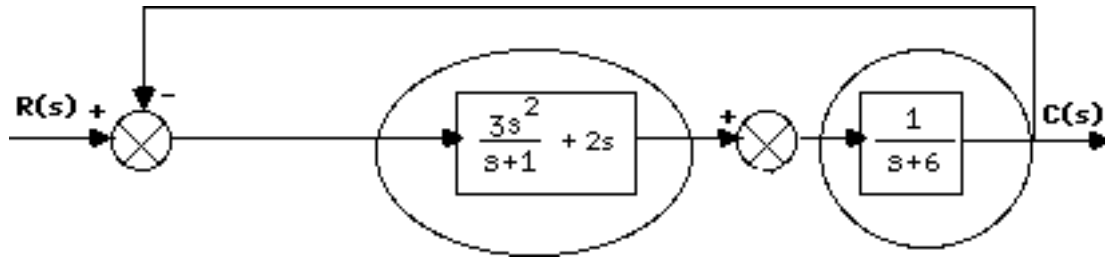

Combine cascade pair and apply final feedback formula yielding  $T(s) = \frac{5s^2 + 2s}{6s^2 + 9s + 6}$ .

8.

Push  $G_3$  to the left past the pickoff point. Push  $G_6$  to the left past the pickoff point.

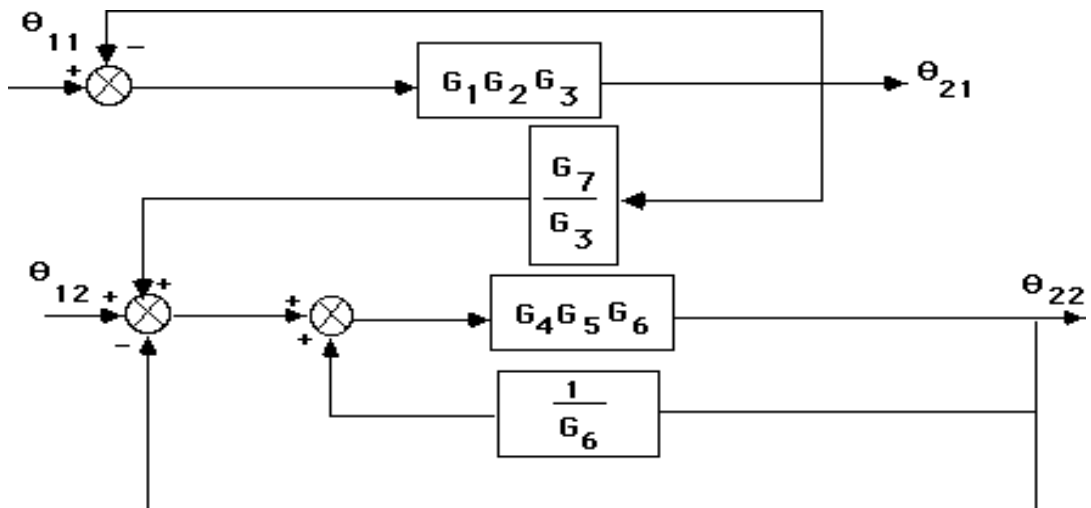

Hence,

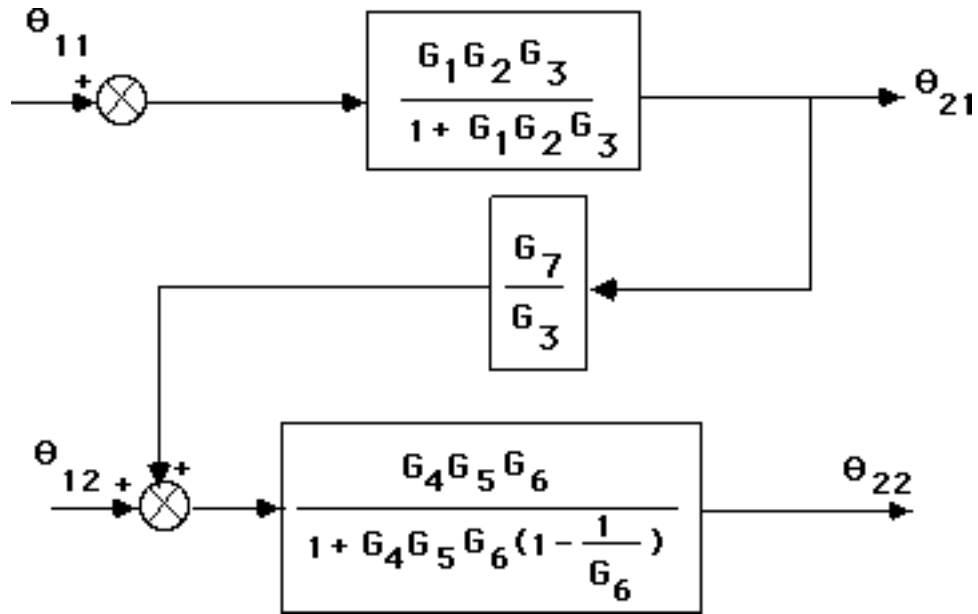

Thus the transfer function is the product of the functions, or

$$\frac{\theta_{22}(s)}{\theta_{11}(s)} = \frac{G_1 G_2 G_4 G_5 G_6 G_7}{1 - G_4 G_5 + G_4 G_5 G_6 + G_1 G_2 G_3 - G_1 G_2 G_3 G_4 G_5 + G_1 G_2 G_3 G_4 G_5 G_6}$$

9.

Combine the feedback with  $G_6$  and combine the parallel  $G_2$  and  $G_3$ .

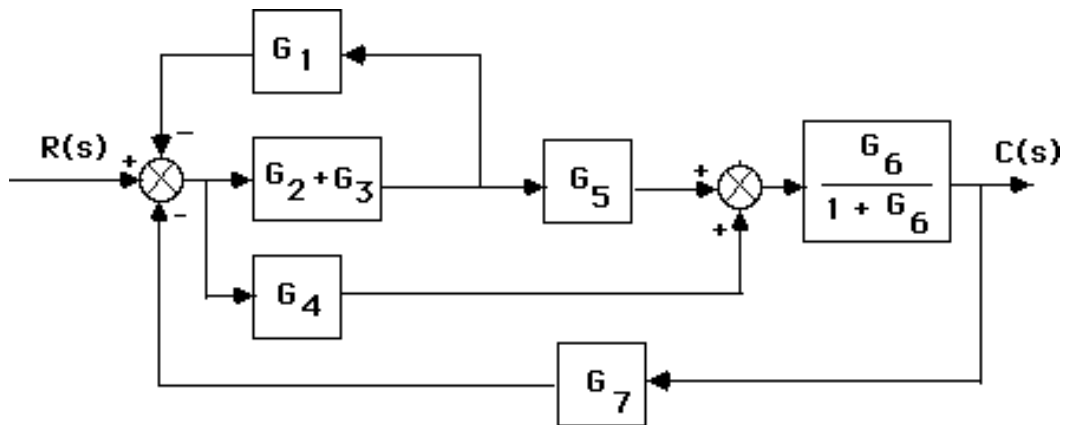

Move  $G_2+G_3$  to the left past the pickoff point.

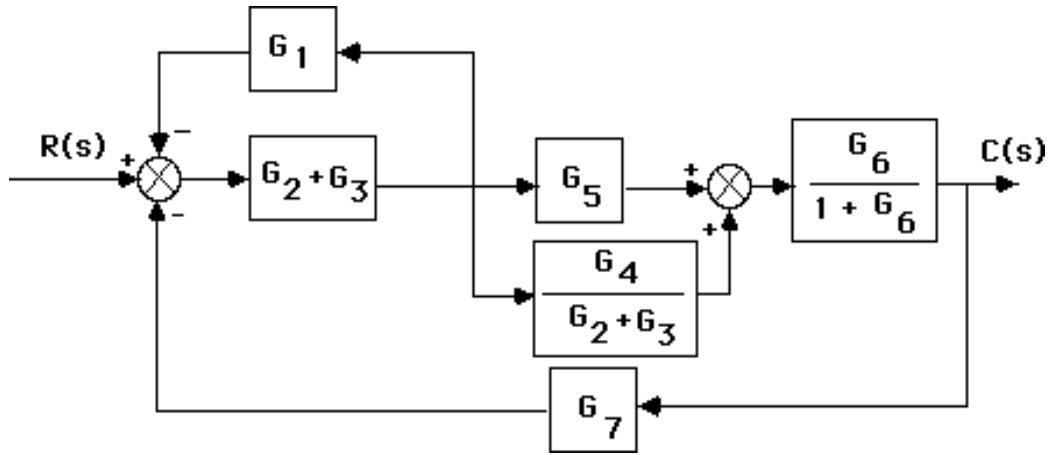

Combine feedback and parallel pair in the forward path yielding an equivalent forward-path transfer function of

$$G_e(s) = \left( \frac{G_2 + G_3}{1 + G_1(G_2 + G_3)} \right) \left( G_5 + \frac{G_4}{G_2 + G_3} \right) \left( \frac{G_6}{1 + G_6} \right)$$

But,  $T(s) = \frac{G_e(s)}{1 + G_e(s)G_7(s)}$ . Thus,

$$T(s) = \frac{G_6 (G_4 + G_5 G_3 + G_5 G_2)}{G_6 (G_7 G_4 + G_7 G_5 G_3 + G_7 G_5 G_2 + G_3 G_1 + G_2 G_1 + 1) + G_1 (G_3 + G_2) + 1}$$

10. Push  $G_3(s)$  to the left past the pickoff point.

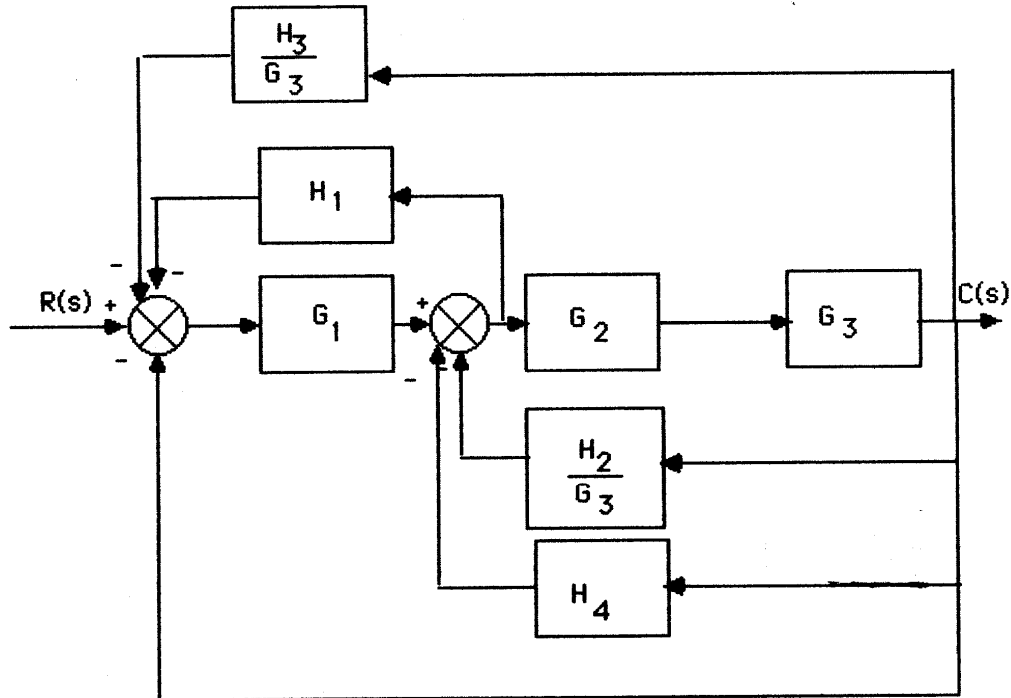

Push  $G_2(s)G_3(s)$  to the left past the pickoff point.

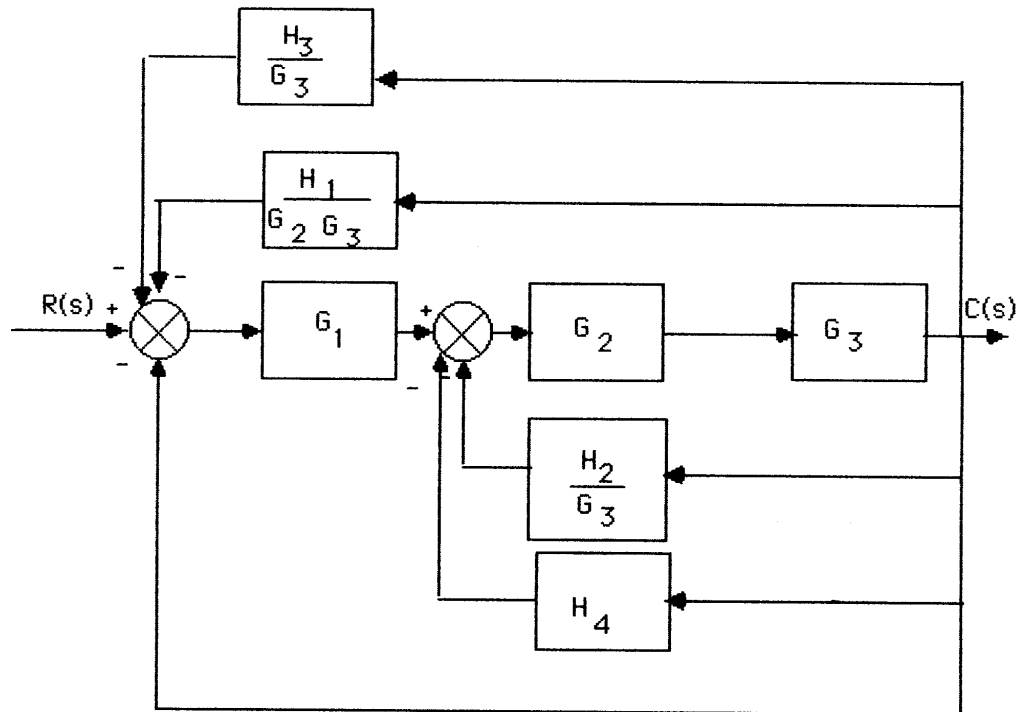

Push  $G_1(s)$  to the right past the summing junction.

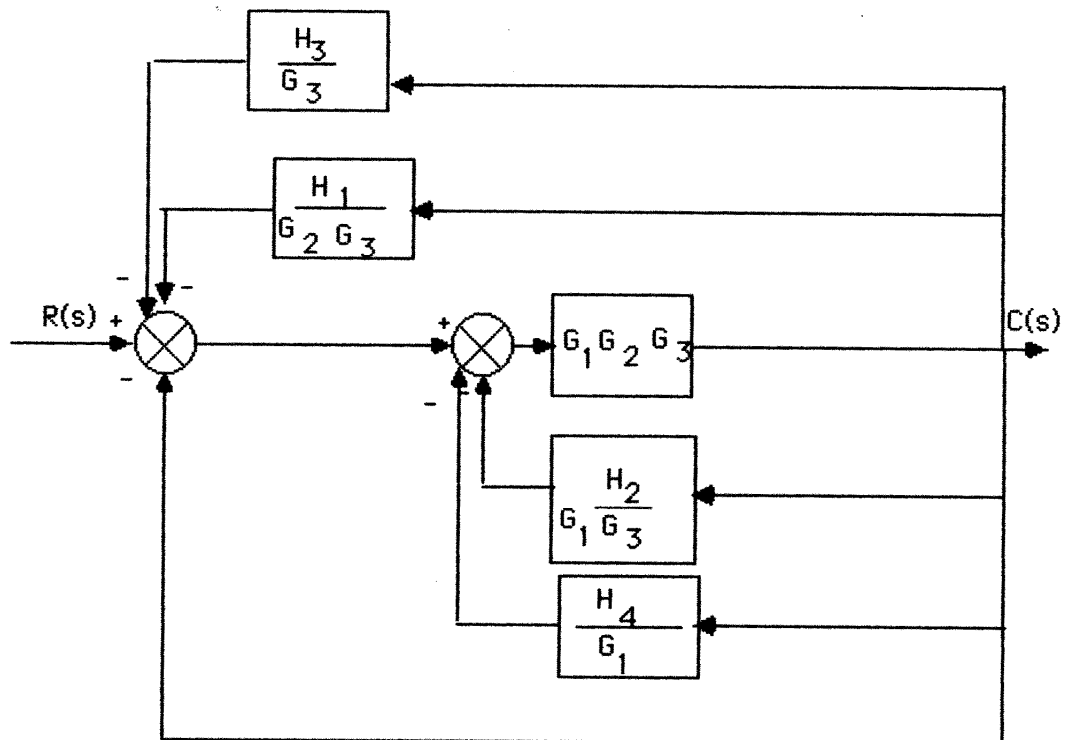

Collapsing the summing junctions and adding the feedback transfer functions,

$$T(s) = \frac{G_1(s)G_2(s)G_3(s)}{1 + G_1(s)G_2(s)G_3(s)H_{eq}(s)}$$

where

$$H_{eq}(s) = \frac{H_3(s)}{G_3(s)} + \frac{H_1(s)}{G_2(s)G_3(s)} + \frac{H_2(s)}{G_1(s)G_3(s)} + \frac{H_4(s)}{G_1(s)} + 1$$

11.

$$T(s) = \frac{225}{s^2 + 15s + 225}. \text{ Therefore, } 2\zeta\omega_n = 15, \text{ and } \omega_n = 15. \text{ Hence, } \zeta = 0.5.$$

$$\%OS = e^{-\zeta\pi/\sqrt{1-\zeta^2}} \times 100 = 16.3\%; T_s = \frac{4}{\zeta\omega_n} = 0.533; T_p = \frac{\pi}{\omega_n\sqrt{1-\zeta^2}} = 0.242.$$

12.

$$C(s) = \frac{5}{s(s^2 + 2s + 5)} = \frac{A}{s} + \frac{Bs + C}{s^2 + 2s + 5}$$

$$A = 1$$

$$5 = s^2 + 2s + 5 + Bs^2 + Cs$$

$$\therefore B = -1, C = -2$$

$$\begin{aligned} C(s) &= \frac{1}{s} - \frac{s+2}{s^2 + 2s + 5} = \frac{1}{s} - \frac{s+2}{(s+1)^2 + 4} \\ &= \frac{1}{s} - \frac{(s+1)+1}{(s+1)^2 + 4} = \frac{1}{s} - \frac{(s+1) + \frac{1}{2} \cdot 2}{(s+1)^2 + 4} \end{aligned}$$

$$c(t) = 1 - e^{-t} \left( \cos 2t + \frac{1}{2} \sin 2t \right)$$

13. Push  $2s$  to the left past the pickoff point and combine the parallel combination of  $2$  and  $1/s$ .

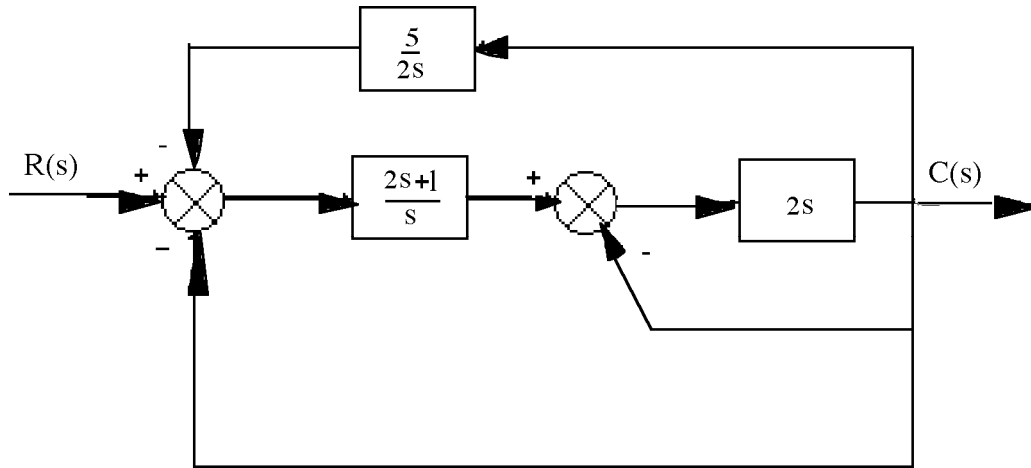

Push  $(2s+1)/s$  to the right past the summing junction and combine summing junctions.

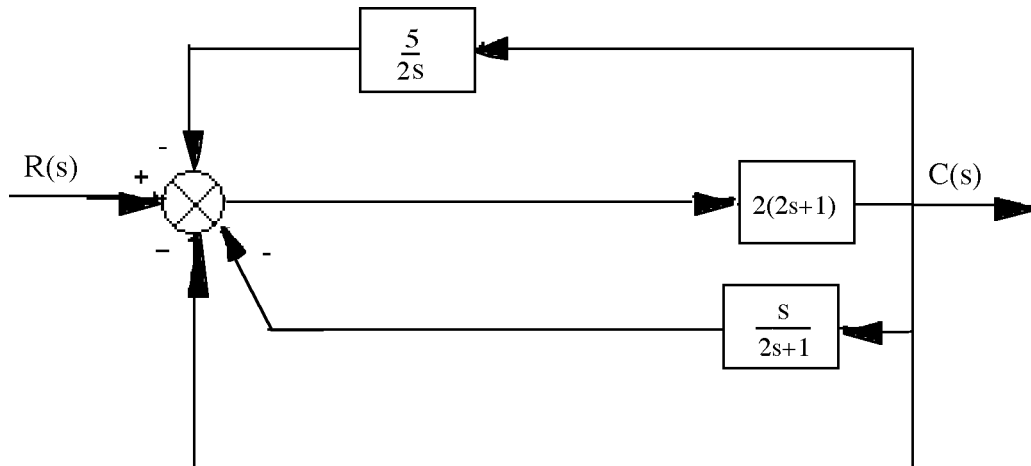

Hence,  $T(s) = \frac{2(2s+1)}{1 + 2(2s+1)H_{eq}(s)}$ , where  $H_{eq}(s) = 1 + \frac{s}{2s+1} + \frac{5}{2s}$ .

14. Since  $G(s) = \frac{K}{s(s+30)}$ ,  $T(s) = \frac{G(s)}{1+G(s)} = \frac{K}{s^2 + 30s + K}$ . Therefore,  $2\zeta\omega_n = 30$ . Thus,  $\zeta =$

$15/\omega_n = 0.5912$  (i.e. 10% overshoot). Hence,  $\omega_n = 25.37 = \sqrt{K}$ . Therefore  $K = 643.6$ .

15.  $T(s) = \frac{K}{s^2 + \alpha s + K}$ ;  $\zeta = \frac{-\ln(\frac{\%OS}{100})}{\sqrt{\pi^2 + \ln^2(\frac{\%OS}{100})}} = 0.358$ ;  $T_s = \frac{4}{\zeta\omega_n} = 0.15$ . Therefore,  $\omega_n =$

$74.49$ .  $K = \omega_n^2 = 5549$ .  $\alpha = 2\zeta\omega_n = 53.33$ .

16.

The equivalent forward-path transfer function is  $G(s) = \frac{10K_1}{s[s + (10K_2 + 2)]}$ . Hence,

$$T(s) = \frac{G(s)}{1 + G(s)} = \frac{10K_1}{s^2 + (10K_2 + 2)s + 10K_1} \text{ . Since}$$

$$T_s = \frac{4}{\text{Re}} = 3.2, \therefore \text{Re} = 1.25; \text{ and } T_p = \frac{\pi}{\text{Im}} = 1.5, \therefore \text{Im} = 2.09 \text{ . The poles are thus at}$$

$-1.25 + j2.09$ . Hence,  $\omega_n = \sqrt{1.25^2 + 2.09^2} = \sqrt{10K_1}$  . Thus,  $K_1 = 0.593$ . Also,  $(10K_2 + 2)/2 = \text{Re} = 1.25$ . Hence,  $K_2 = 0.05$ .

17.

a. For the inner loop,  $G_e(s) = \frac{20}{s(s + 12)}$ , and  $H_e(s) = 0.2s$ . Therefore,  $T_e(s) = \frac{G_e(s)}{1 + G_e(s)H_e(s)} = \frac{20}{s(s+16)}$  . Combining with the equivalent transfer function of the parallel pair,  $G_p(s) = 20$ , the system is reduced to an equivalent unity feedback system with  $G(s) = G_p(s) T_e(s) = \frac{400}{s(s+16)}$  . Hence,  $T(s) = \frac{G(s)}{1 + G(s)} = \frac{400}{s^2 + 16s + 400}$  .

b.  $\omega_n^2 = 400$ ;  $2\zeta\omega_n = 16$ . Therefore,  $\omega_n = 20$ , and  $\zeta = 0.4$ .  $\%OS = e^{-\zeta\pi/\sqrt{1-\zeta^2}} \times 100 = 25.38$ ;

$$T_s = \frac{4}{\zeta\omega_n} = 0.5; T_p = \frac{\pi}{\omega_n\sqrt{1-\zeta^2}} = 0.171 \text{ . From Figure 4.16, } \omega_n T_r = 1.463 \text{ . Hence, } T_r = 0.0732 \text{ .}$$

$$\omega_d = \text{Im} = \omega_n\sqrt{1-\zeta^2} = 18.33 \text{ .}$$

18.

$T(s) = \frac{38343}{s^2 + 200s + 38343}$ ; from which,  $2\zeta\omega_n = 200$  and  $\omega_n = \sqrt{38343} = 195.81$ . Hence,

$$\zeta = 0.511 \text{ . } \%OS = e^{-\zeta\pi/\sqrt{1-\zeta^2}} \times 100 = 15.44\% ; T_p = \frac{\pi}{\omega_n\sqrt{1-\zeta^2}} = 0.0187 \text{ s .}$$

$$\text{Also, } T_s = \frac{4}{\zeta\omega_n} = 0.04 \text{ s .}$$

19.

For the generator,  $E_g(s) = K_f I_f(s)$ . But,  $I_f(s) = \frac{E_i(s)}{R_f + L_f s}$  . Therefore,  $\frac{E_g(s)}{E_i(s)} = \frac{2}{s+1}$  . For the motor,

consider  $R_a = 2 \Omega$ , the sum of both resistors. Also,  $J_e = J_a + J_L (\frac{1}{2})^2 = 0.75 + 4 \times \frac{1}{4} = 1.75$ ;  $D_e = D_L (\frac{1}{2})^2 = 1$ . Therefore,



$$\frac{\theta_m(s)}{E_g(s)} = \frac{\frac{K_t}{R_a J_e}}{s(s + \frac{1}{J_e}(D_e + \frac{K_t K_b}{R_a}))} = \frac{0.286}{s(s + 0.857)}$$

But,  $\frac{\theta_o(s)}{\theta_m(s)} = \frac{1}{2}$ . Thus,  $\frac{\theta_o(s)}{E_g(s)} = \frac{0.143}{s(s + 0.857)}$ . Finally,

$$\frac{\theta_o(s)}{E_i(s)} = \frac{E_g(s)}{E_i(s)} \frac{\theta_o(s)}{E_g(s)} = \frac{0.286}{s(s + 1)(s + 0.857)}$$

20.

For the mechanical system,  $J\left(\frac{N_2}{N_1}\right)^2 s^2 \theta_2(s) = T\left(\frac{N_2}{N_1}\right)$ . For the potentiometer,  $E_i(s) = 10 \frac{\theta_2(s)}{2\pi}$ , or

$$\theta_2(s) = \frac{\pi}{5} E_i(s). \text{ For the network, } E_o(s) = E_i(s) \frac{R}{R + \frac{1}{Cs}} = E_i(s) \frac{s}{s + \frac{1}{RC}}, \text{ or } E_i(s) = E_o(s) \frac{s + \frac{1}{RC}}{s}.$$

Therefore,  $\theta_2(s) = \frac{\pi}{5} E_o(s) \frac{s + \frac{1}{RC}}{s}$ . Substitute into mechanical equation and obtain,

$$\frac{E_o(s)}{T(s)} = \frac{5N_1}{J\pi N_2} \frac{1}{s\left(s + \frac{1}{RC}\right)}$$

21.

The equivalent mechanical system is found by reflecting mechanical impedances to the spring.

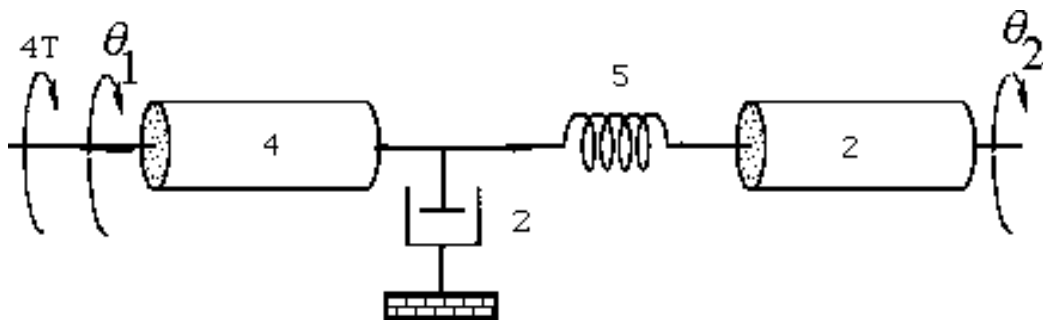

Writing the equations of motion:

$$(4s^2 + 2s + 5)\theta_1(s) - 5\theta_2(s) = 4T(s)$$

$$-5\theta_1(s) + (2s^2 + 5)\theta_2(s) = 0$$

Solving for  $\theta_2(s)$ ,

$$\theta_2(s) = \frac{\begin{vmatrix} (4s^2 + 2s + 5) & 4T(s) \\ -5 & 0 \end{vmatrix}}{\begin{vmatrix} (4s^2 + 2s + 5) & -5 \\ -5 & (2s^2 + 5) \end{vmatrix}} = \frac{20T(s)}{8s^4 + 4s^3 + 30s^2 + 10s}$$

The angular rotation of the pot is 0.2 that of  $\theta_2$ , or

$$\frac{\theta_p(s)}{T(s)} = \frac{2}{s(4s^3 + 2s^2 + 15s + 5)}$$

For the pot:

$$\frac{E_p(s)}{\theta_p(s)} = \frac{50}{5(2\pi)} = \frac{5}{\pi}$$

For the electrical network: Using voltage division,

$$\frac{E_o(s)}{E_p(s)} = \frac{200,000}{\frac{1}{10^{-5}s} + 200,000} = \frac{s}{s + \frac{1}{2}}$$

Substituting the previously obtained values,

$$\frac{E_o(s)}{T(s)} = \left( \frac{\theta_p(s)}{T(s)} \right) \left( \frac{E_p(s)}{\theta_p(s)} \right) \left( \frac{E_o(s)}{E_p(s)} \right) = \frac{\frac{10}{\pi} s}{s \left( s + \frac{1}{2} \right) (4s^3 + 2s^2 + 15s + 5)}$$

22.

a.

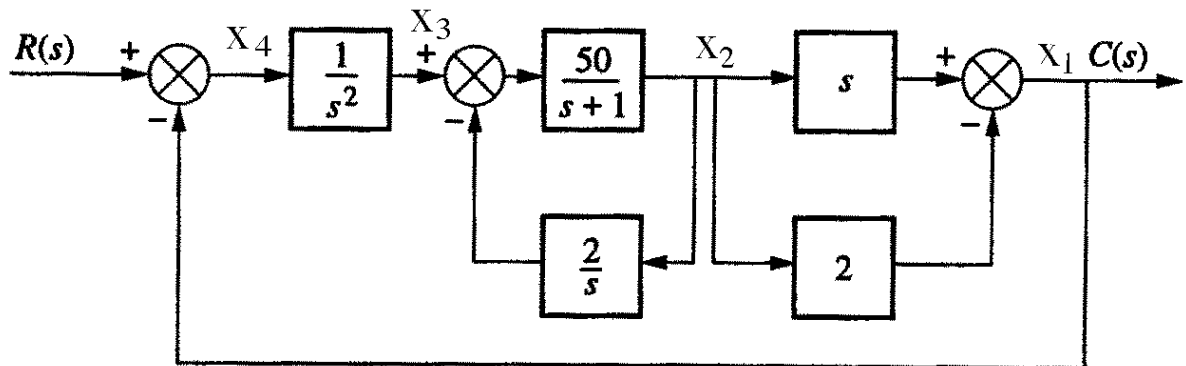

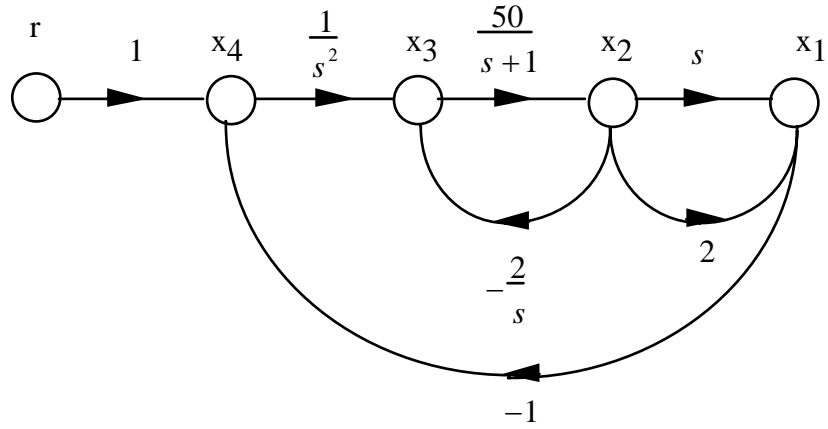

b.

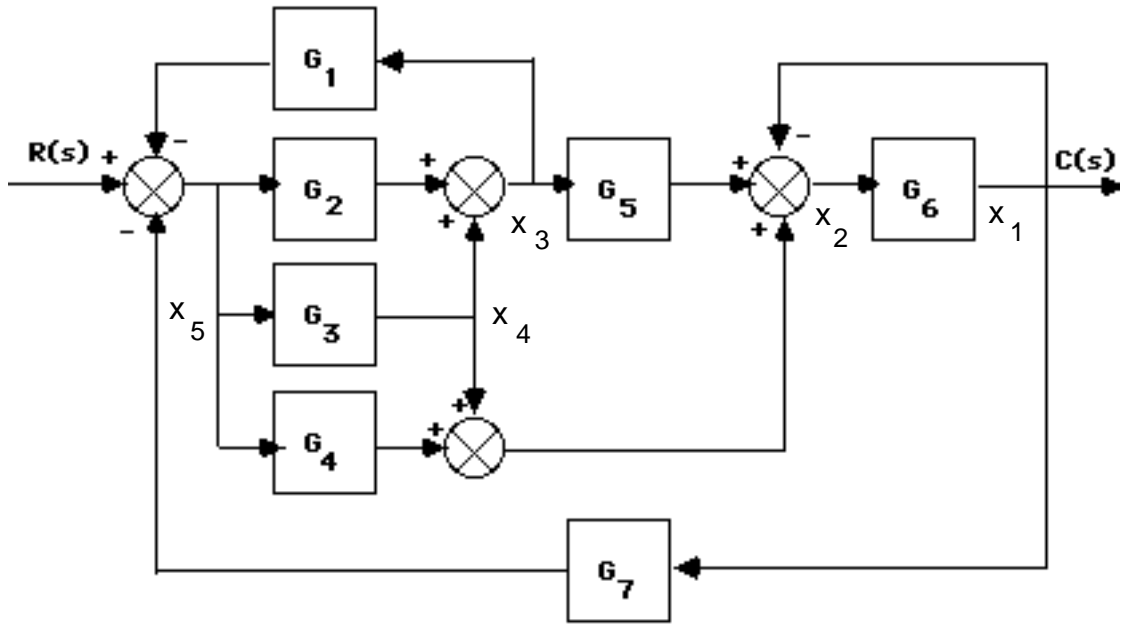

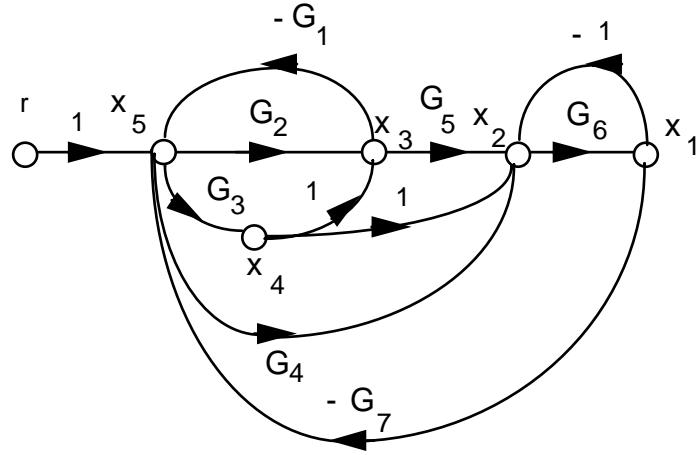

c.

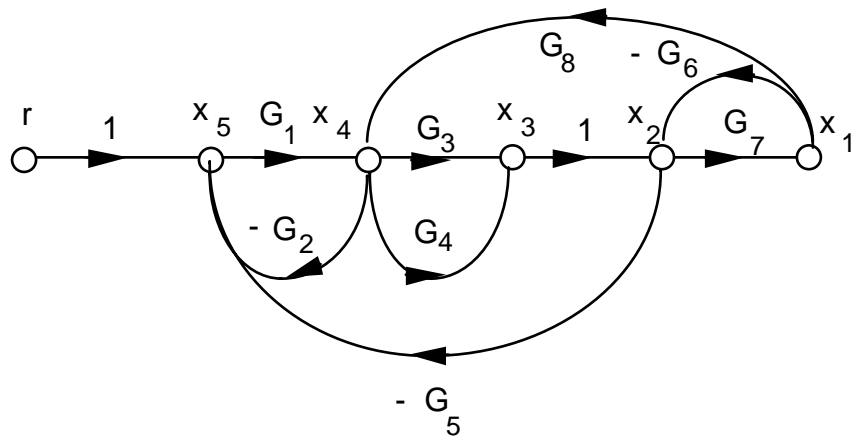
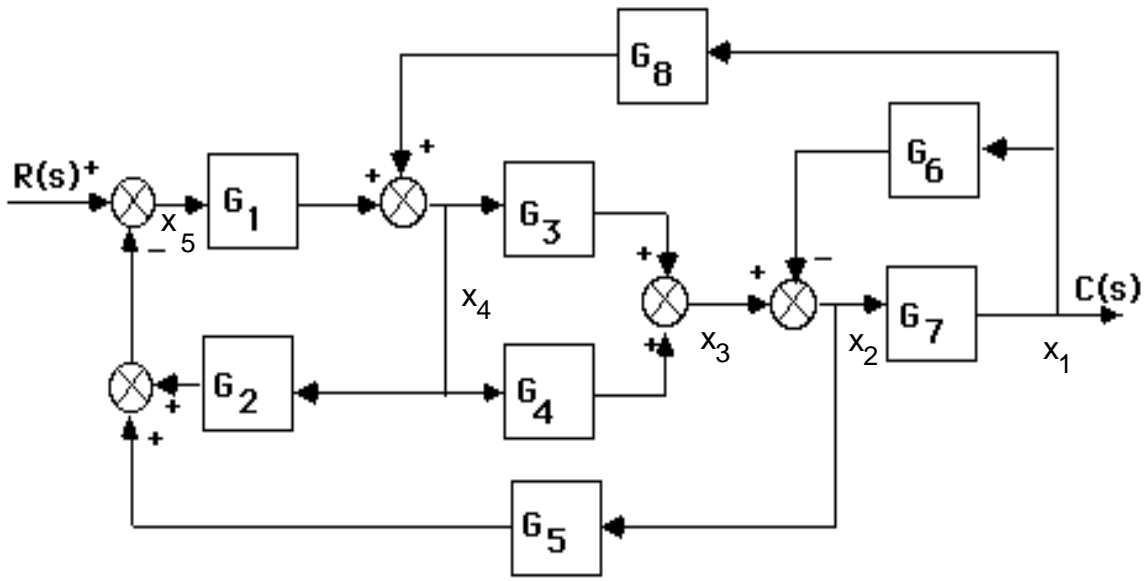

23. a.

$$\begin{aligned} \dot{x}_1 &= x_2 \\ \dot{x}_2 &= x_3 \\ \dot{x}_3 &= -2x_1 - 4x_2 - 6x_3 + r \\ y &= x_1 + x_2 \end{aligned}$$

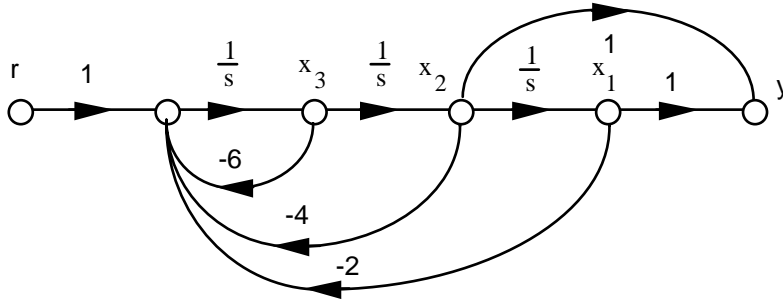

b.

$$\begin{aligned} \dot{x}_1 &= x_2 \\ \dot{x}_2 &= -3x_2 + x_3 + r \\ \dot{x}_3 &= -3x_1 - 4x_2 - 5x_3 + r \\ y &= x_1 + 2x_2 \end{aligned}$$

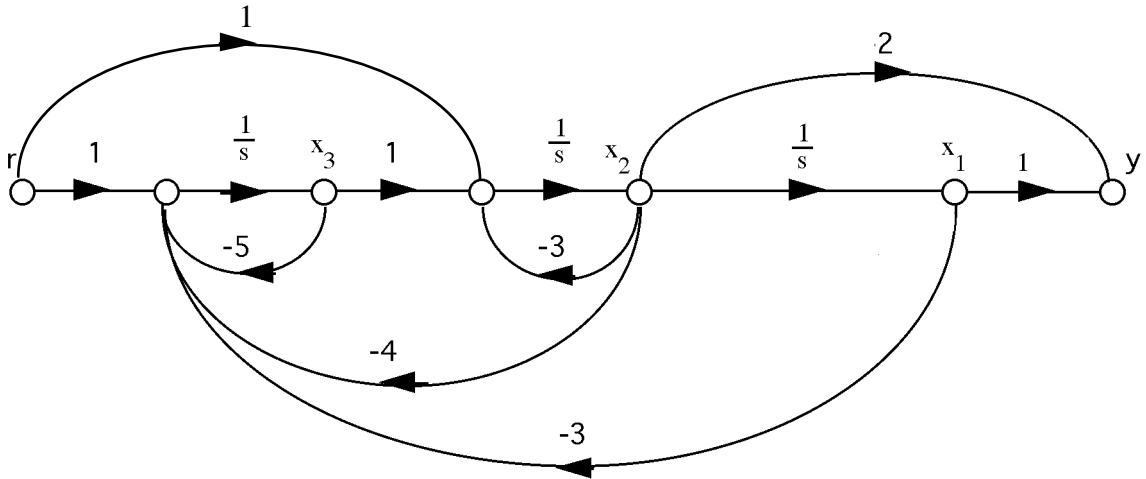

c.

$$\dot{x}_1 = 7x_1 + x_2 + r$$

$$\dot{x}_2 = -3x_1 + 2x_2 - x_3 + 2r$$

$$\dot{x}_3 = -x_1 + 2x_3 + r$$

$$y = x_1 + 3x_2 + 2x_3$$

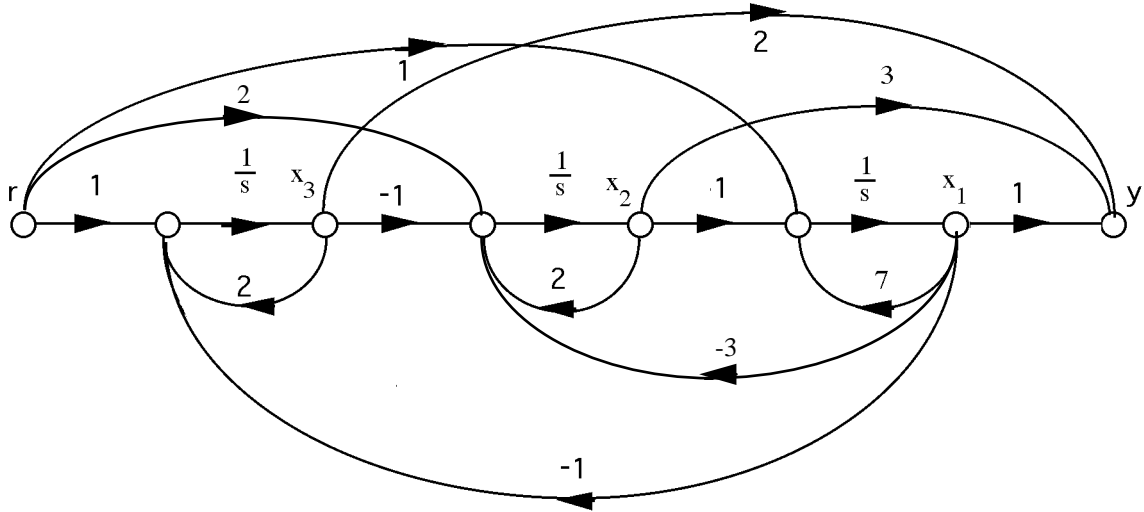

24.

a. Since  $G(s) = \frac{10}{s^3 + 24s^2 + 191s + 504} = \frac{C(s)}{R(s)}$ ,

$$\overset{\dots}{c} + 24\overset{\dots}{c} + 191\overset{\cdot}{c} + 504c = 10r$$

Let,

$$c = x_1$$

$$\overset{\cdot}{c} = x_2$$

$$\overset{\dots}{c} = x_3$$

Therefore,

$$\overset{\cdot}{x}_1 = x_2$$

$$\overset{\cdot}{x}_2 = x_3$$

$$\overset{\cdot}{x}_3 = -504x_1 - 191x_2 - 24x_3 + 10r$$

$$y = x_1$$

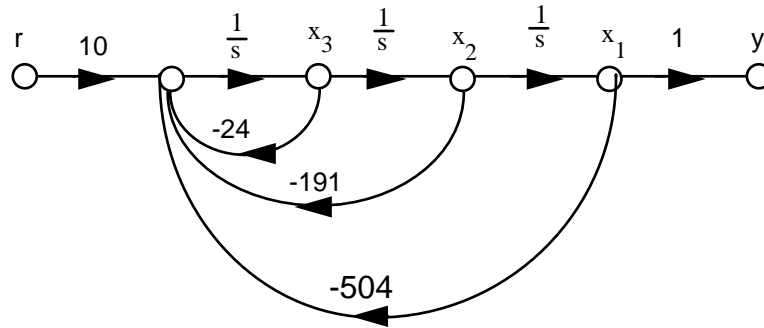

b.  $G(s) = \left(\frac{10}{s+7}\right) \left(\frac{1}{s+8}\right) \left(\frac{1}{s+9}\right)$

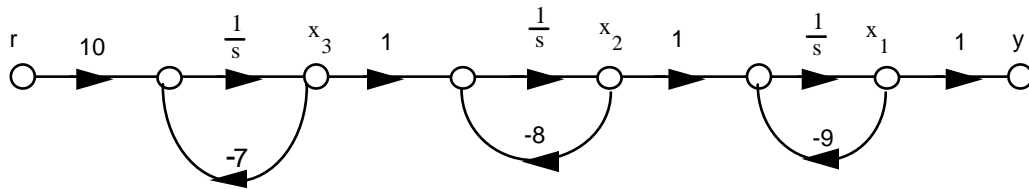

Therefore,

$$\begin{aligned} \dot{x}_1 &= -9x_1 + x_2 \\ \dot{x}_2 &= -8x_2 + x_3 \\ \dot{x}_3 &= -7x_3 + 10r \\ y &= x_1 \end{aligned}$$

25.

a. Since  $G(s) = \frac{20}{s^4 + 15s^3 + 66s^2 + 80s} = \frac{C(s)}{R(s)}$ ,

$$\overset{\bullet\bullet\bullet}{c} + 15 \overset{\bullet\bullet}{c} + 66 \overset{\bullet}{c} + 80 c = 20r$$

Let,

$$\begin{aligned} c &= x_1 \\ \dot{c} &= x_2 \\ \ddot{c} &= x_3 \\ \overset{\bullet\bullet\bullet}{c} &= x_4 \end{aligned}$$

Therefore,

$$\begin{aligned} \dot{x}_1 &= x_2 \\ \dot{x}_2 &= x_3 \\ \dot{x}_3 &= x_4 \\ \dot{x}_4 &= -80x_2 - 66x_3 - 15x_4 + 20r \\ y &= x_1 \end{aligned}$$

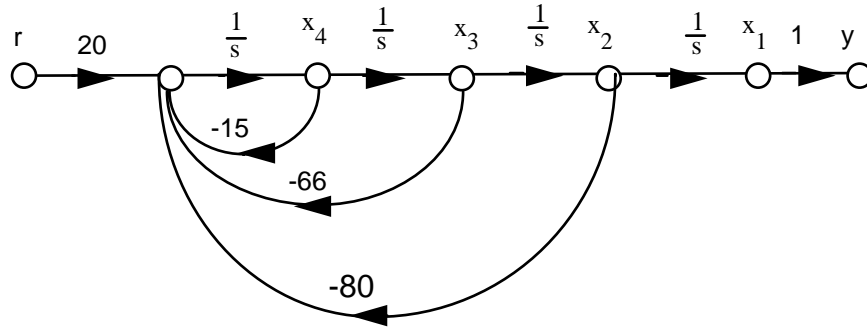

b.  $G(s) = \left(\frac{20}{s}\right) \left(\frac{1}{s+2}\right) \left(\frac{1}{s+5}\right) \left(\frac{1}{s+8}\right)$ . Hence,

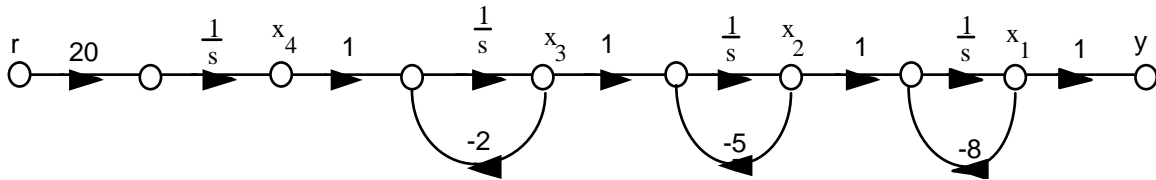

From which,

$$\begin{aligned} \dot{x}_1 &= -8x_1 + x_2 \\ \dot{x}_2 &= -5x_2 + x_3 \\ \dot{x}_3 &= -2x_3 + x_4 \\ \dot{x}_4 &= 20r \\ y &= x_1 \end{aligned}$$

26.

$\Delta = 1 + [G_2G_3G_4 + G_3G_4 + G_4 + 1] + [G_3G_4 + G_4]$ ;  $T_1 = G_1G_2G_3G_4$ ;  $\Delta_1 = 1$ . Therefore,

$$T(s) = \frac{T_1\Delta_1}{\Delta} = \frac{G_1G_2G_3G_4}{2 + G_2G_3G_4 + 2G_3G_4 + 2G_4}$$



27.

Closed-loop gains:  $G_2G_4G_6G_7H_3$ ;  $G_2G_5G_6G_7H_3$ ;  $G_3G_4G_6G_7H_3$ ;  $G_3G_5G_6G_7H_3$ ;  $G_6H_1$ ;  $G_7H_2$ Forward-path gains:  $T_1 = G_1G_2G_4G_6G_7$ ;  $T_2 = G_1G_2G_5G_6G_7$ ;  $T_3 = G_1G_3G_4G_6G_7$ ;  $T_4 =$  $G_1G_3G_5G_6G_7$ Nontouching loops 2 at a time:  $G_6H_1G_7H_2$  $\Delta = 1 - [H_3G_6G_7(G_2G_4 + G_2G_5 + G_3G_4 + G_3G_5) + G_6H_1 + G_7H_2] + [G_6H_1G_7H_2]$  $\Delta_1 = \Delta_2 = \Delta_3 = \Delta_4 = 1$ 

$$T(s) = \frac{T_1\Delta_1 + T_2\Delta_2 + T_3\Delta_3 + T_4\Delta_4}{\Delta}$$

$$= \frac{G_1G_2G_4G_6G_7 + G_1G_2G_5G_6G_7 + G_1G_3G_4G_6G_7 + G_1G_3G_5G_6G_7}{1 - H_3G_6G_7(G_2G_4 + G_2G_5 + G_3G_4 + G_3G_5) - G_6H_1 - G_7H_2 + G_6H_1G_7H_2}$$

28.

Closed-loop gains:  $-s^2$ ;  $-\frac{1}{s}$ ;  $-\frac{1}{s}$ ;  $-s^2$ Forward-path gains:  $T_1 = s$ ;  $T_2 = \frac{1}{s^2}$ 

Nontouching loops: None

 $\Delta = 1 - (-s^2 - \frac{1}{s} - \frac{1}{s} - s^2)$  $\Delta_1 = \Delta_2 = 1$ 

$$G(s) = \frac{T_1\Delta_1 + T_2\Delta_2}{\Delta} = \frac{s + \frac{1}{s^2}}{1 + (s^2 + \frac{1}{s} + \frac{1}{s} + s^2)} = \frac{s^3 + 1}{2s^4 + s^2 + 2s}$$

29.

$$T(s) = \frac{G_1 \left( \frac{G_2G_3G_4G_5}{(1-G_2H_1)(1-G_4H_2)} \right)}{1 - \frac{G_2G_3G_4G_5G_6G_7G_8}{(1-G_2H_1)(1-G_4H_2)(1-G_7H_4)}} =$$

$$\frac{G_1G_2G_3G_4G_5(1-G_7H_4)}{1-G_2H_1-G_4H_2+G_2G_4H_1H_2-G_7H_4+G_2G_7H_1H_4+G_4G_7H_2H_4-G_2G_4G_7H_1H_2H_4-G_2G_3G_4G_5G_6G_7G_8}$$

30.

$$\text{a. } G(s) = \frac{(s+1)(s+2)}{(s+3)^2(s+4)} = \frac{2}{(s+3)^2} - \frac{5}{s+3} + \frac{6}{s+4}$$

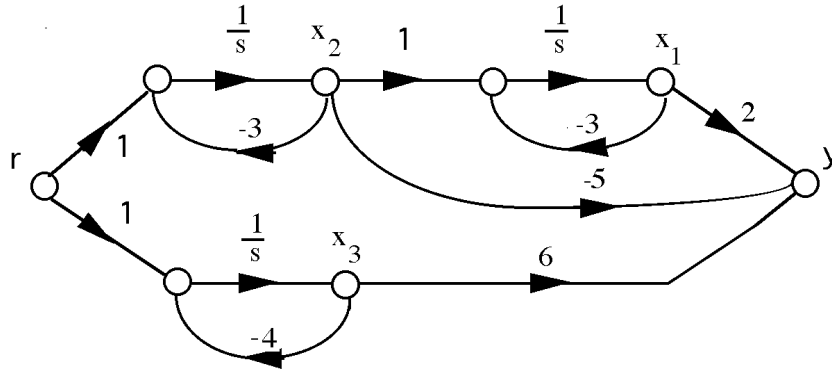

Writing the state and output equations,

$$\dot{x}_1 = -3x_1 + x_2$$

$$\dot{x}_2 = -3x_2 + r$$

$$\dot{x}_3 = -4x_3 + r$$

$$y = 2x_1 - 5x_2 + 6x_3$$

In vector-matrix form,

$$\dot{\mathbf{x}} = \begin{bmatrix} -3 & 1 & 0 \\ 0 & -3 & 0 \\ 0 & 0 & -4 \end{bmatrix} \mathbf{x} + \begin{bmatrix} 0 \\ 1 \\ 1 \end{bmatrix} r$$

$$y = [2 \quad -5 \quad 6]$$

b.  $G(s) = G(s) = \frac{(s+2)}{(s+5)^2(s+7)^2} = -\frac{3/4}{(s+5)^2} + \frac{1}{s+5} - \frac{5/4}{(s+7)^2} - \frac{1}{s+7}$

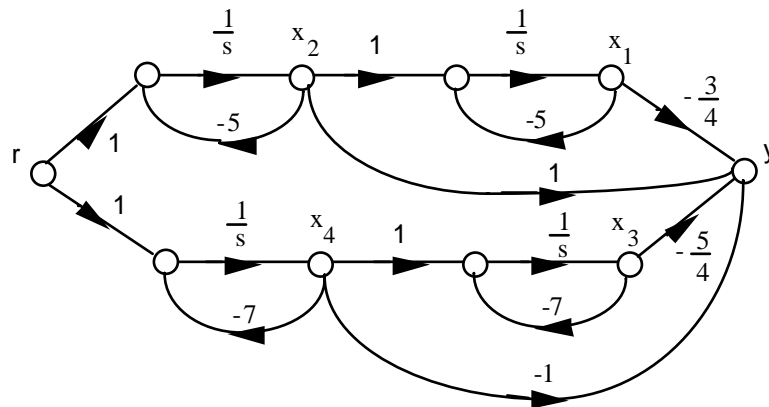

Writing the state and output equations,

$$\dot{x}_1 = -5x_1 + x_2$$

$$\begin{aligned}\dot{x}_2 &= -5x_2 + r \\ \dot{x}_3 &= -7x_3 + x_4 \\ \dot{x}_4 &= -7x_4 + r \\ y &= -\frac{3}{4}x_1 + x_2 - \frac{5}{4}x_3 - x_4\end{aligned}$$

In vector matrix form,

$$\dot{\mathbf{x}} = \begin{bmatrix} -5 & 1 & 0 & 0 \\ 0 & -5 & 0 & 0 \\ 0 & 0 & -7 & 1 \\ 0 & 0 & 0 & -7 \end{bmatrix} \mathbf{x} + \begin{bmatrix} 0 \\ 1 \\ 0 \\ 1 \end{bmatrix} r$$

$$y = \begin{bmatrix} -\frac{3}{4} & 1 & -\frac{5}{4} & -1 \end{bmatrix} \mathbf{x}$$

c.

$$G(s) = \frac{s+3}{(s+2)^2(s+4)(s+5)} = \frac{2}{9} \frac{1}{s+5} - \frac{1}{4} \frac{1}{s+4} + \frac{1}{36} \frac{1}{s+2} + \frac{1}{6} \frac{1}{(s+2)^2}$$

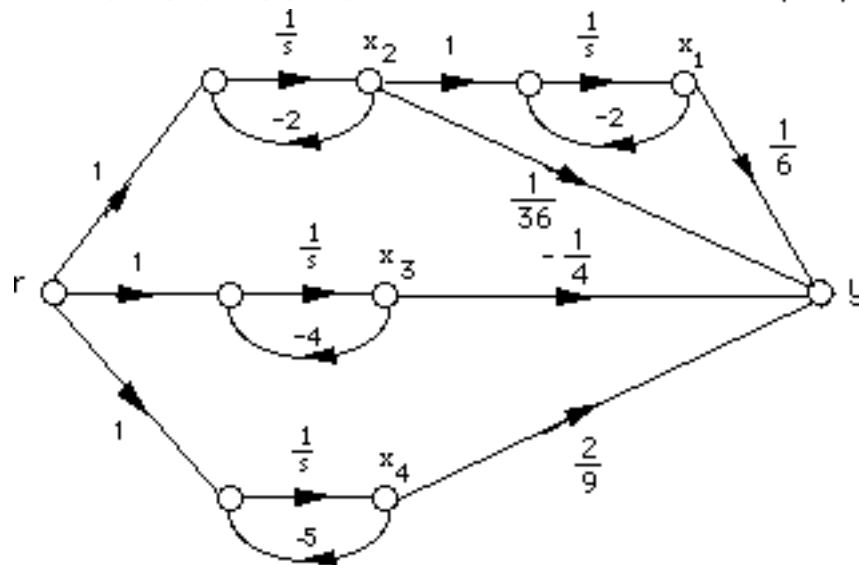

Writing the state and output equations,

$$\begin{aligned}\dot{x}_1 &= -2x_1 + x_2 \\ \dot{x}_2 &= -2x_2 + r \\ \dot{x}_3 &= -4x_3 + r \\ \dot{x}_4 &= -5x_4 + r \\ y &= \frac{1}{6}x_1 + \frac{1}{36}x_2 - \frac{1}{4}x_3 + \frac{2}{9}x_4\end{aligned}$$

In vector-matrix form,

$$\dot{\mathbf{x}} = \begin{bmatrix} -2 & 1 & 0 & 0 \\ 0 & -2 & 0 & 0 \\ 0 & 0 & -4 & 0 \\ 0 & 0 & 0 & -5 \end{bmatrix} \mathbf{x} + \begin{bmatrix} 0 \\ 1 \\ 1 \\ 1 \end{bmatrix} r$$

$$y = \begin{bmatrix} \frac{1}{6} & \frac{1}{36} & -\frac{1}{4} & \frac{2}{9} \end{bmatrix} \mathbf{x}$$

31.  
a.

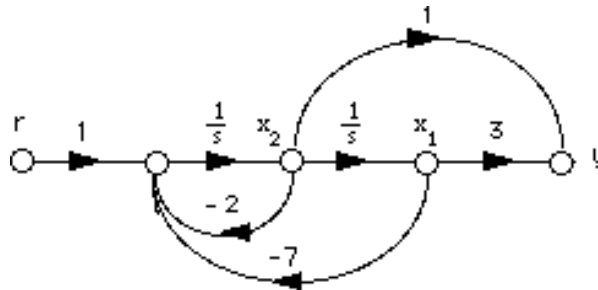

Writing the state equations,

$$\dot{x}_1 = x_2$$

$$\dot{x}_2 = -7x_1 - 2x_2 + r$$

$$y = 3x_1 + x_2$$

In vector matrix form,

$$\dot{\mathbf{x}} = \begin{bmatrix} 0 & 1 \\ -7 & -2 \end{bmatrix} \mathbf{x} + \begin{bmatrix} 0 \\ 1 \end{bmatrix} r$$

$$y = \begin{bmatrix} 3 & 1 \end{bmatrix} \mathbf{x}$$



c.

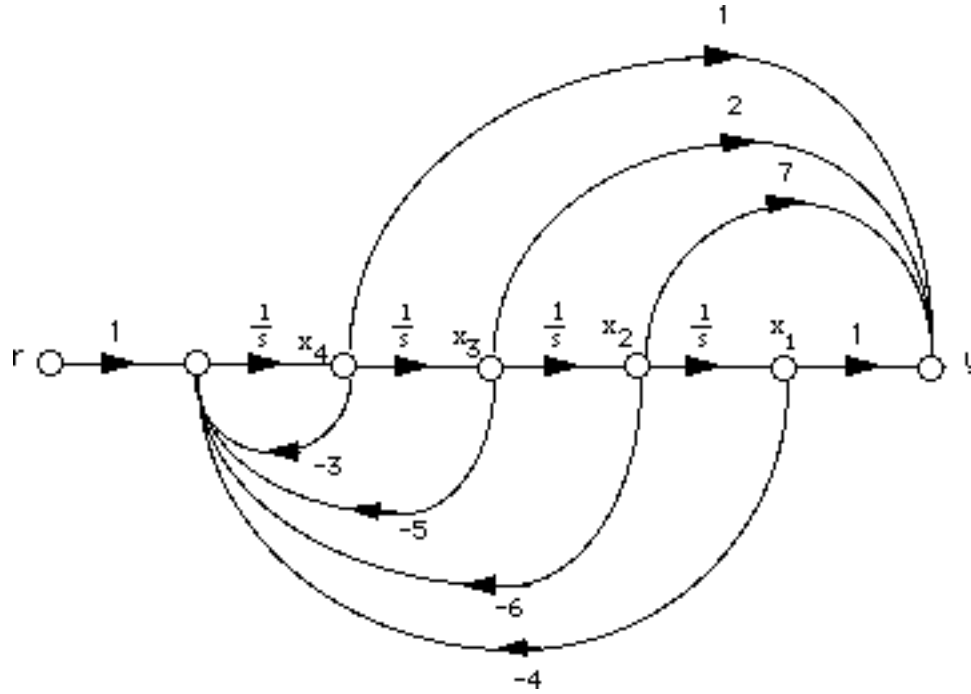

$$\begin{aligned} \dot{x}_1 &= x_2 \\ \dot{x}_2 &= x_3 \\ \dot{x}_3 &= x_4 \\ \dot{x}_4 &= -4x_1 - 6x_2 - 5x_3 - 3x_4 + r \\ y &= x_1 + 7x_2 + 2x_3 + x_4 \end{aligned}$$

In vector matrix form,

$$\dot{\mathbf{x}} = \begin{bmatrix} 0 & 1 & 0 & 0 \\ 0 & 0 & 1 & 0 \\ 0 & 0 & 0 & 1 \\ -4 & -6 & -5 & -3 \end{bmatrix} \mathbf{x} + \begin{bmatrix} 0 \\ 0 \\ 0 \\ 1 \end{bmatrix} r$$

$$y = \begin{bmatrix} 1 & 7 & 2 & 1 \end{bmatrix} \mathbf{x}$$

32.

a. Controller canonical form:

From the phase-variable form in Problem 5.31(a), reverse the order of the state variables and obtain,

$$\begin{aligned}\dot{x}_2 &= x_1 \\ \dot{x}_1 &= -7x_2 - 2x_1 + r \\ y &= 3x_2 + x_1\end{aligned}$$

Putting the equations in order,

$$\begin{aligned}\dot{x}_1 &= -2x_1 - 7x_2 + r \\ \dot{x}_2 &= x_1 \\ y &= x_1 + 3x_2\end{aligned}$$

In vector-matrix form,

$$\begin{aligned}\dot{\mathbf{x}} &= \begin{bmatrix} -2 & -7 \\ 1 & 0 \end{bmatrix} \mathbf{x} + \begin{bmatrix} 1 \\ 0 \end{bmatrix} r \\ y &= \begin{bmatrix} 1 & 3 \end{bmatrix} \mathbf{x}\end{aligned}$$

Observer canonical form:

$$G(s) = \frac{s+3}{s^2+2s+7} \text{ . Divide each term by } \frac{1}{s^2} \text{ and get}$$

$$G(s) = \frac{\frac{1}{s} + \frac{3}{s^2}}{1 + \frac{2}{s} + \frac{7}{s^2}} = \frac{C(s)}{R(s)}$$

Cross multiplying,

$$\left(\frac{1}{s} + \frac{3}{s^2}\right) R(s) = \left(1 + \frac{2}{s} + \frac{7}{s^2}\right) C(s)$$

Thus,

$$\frac{1}{s}(R(s) - 2C(s)) + \frac{1}{s^2}(3R(s) - 7C(s)) = C(s)$$

Drawing the signal-flow graph,

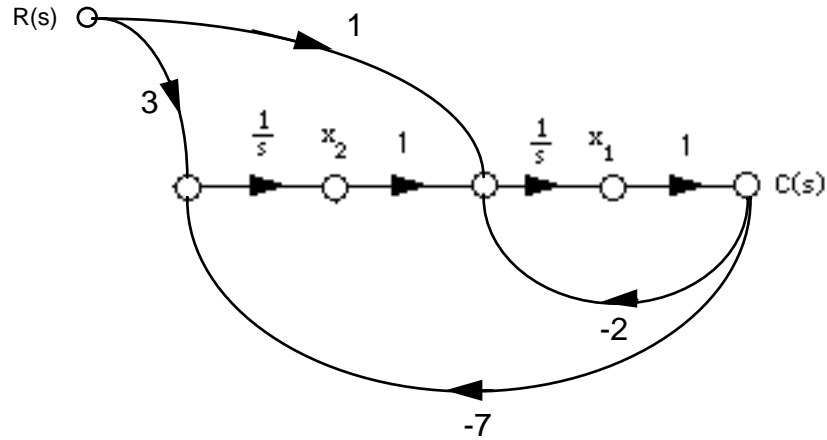

Writing the state and output equations,

$$\dot{x}_1 = -2x_1 + x_2 + r$$

$$\dot{x}_2 = -7x_1 + 3r$$

$$y = x_1$$

In vector matrix form,

$$\dot{\mathbf{x}} = \begin{bmatrix} -2 & 1 \\ -7 & 0 \end{bmatrix} \mathbf{x} + \begin{bmatrix} 1 \\ 3 \end{bmatrix} r$$

$$y = \begin{bmatrix} 1 & 0 \end{bmatrix} \mathbf{x}$$

**b.** Controller canonical form:

From the phase-variable form in Problem 5.31(b), reverse the order of the state variables and obtain,

$$\dot{x}_3 = x_2$$

$$\dot{x}_2 = x_1$$

$$\dot{x}_1 = -x_3 - 2x_2 - 5x_1$$

$$y = 6x_3 + 2x_2 + x_1$$

Putting the equations in order,

$$\dot{x}_1 = -5x_1 - 2x_2 - x_3$$

$$\dot{x}_2 = x_1$$

$$\dot{x}_3 = x_2$$

$$y = x_1 + 2x_2 + 6x_3$$

In vector-matrix form,



$$\dot{\mathbf{x}} = \begin{bmatrix} -5 & -2 & -1 \\ 1 & 0 & 0 \\ 0 & 1 & 0 \end{bmatrix} \mathbf{x} + \begin{bmatrix} 1 \\ 0 \\ 0 \end{bmatrix} r$$

$$y = [1 \quad 2 \quad 6] \mathbf{x}$$

Observer canonical form:

$$G(s) = \frac{s^2 + 2s + 6}{s^3 + 5s^2 + 2s + 1}. \text{ Divide each term by } \frac{1}{s^3} \text{ and get}$$

$$G(s) = \frac{\frac{1}{s} + \frac{2}{s^2} + \frac{6}{s^3}}{1 + \frac{5}{s} + \frac{2}{s^2} + \frac{1}{s^3}} = \frac{C(s)}{R(s)}$$

Cross-multiplying,

$$\left(\frac{1}{s} + \frac{2}{s^2} + \frac{6}{s^3}\right)R(s) = \left(1 + \frac{5}{s} + \frac{2}{s^2} + \frac{1}{s^3}\right)C(s)$$

Thus,

$$\frac{1}{s}(R(s) - 5C(s)) + \frac{1}{s^2}(2R(s) - 2C(s)) + \frac{1}{s^3}(6R(s) - C(s)) = C(s)$$

Drawing the signal-flow graph,

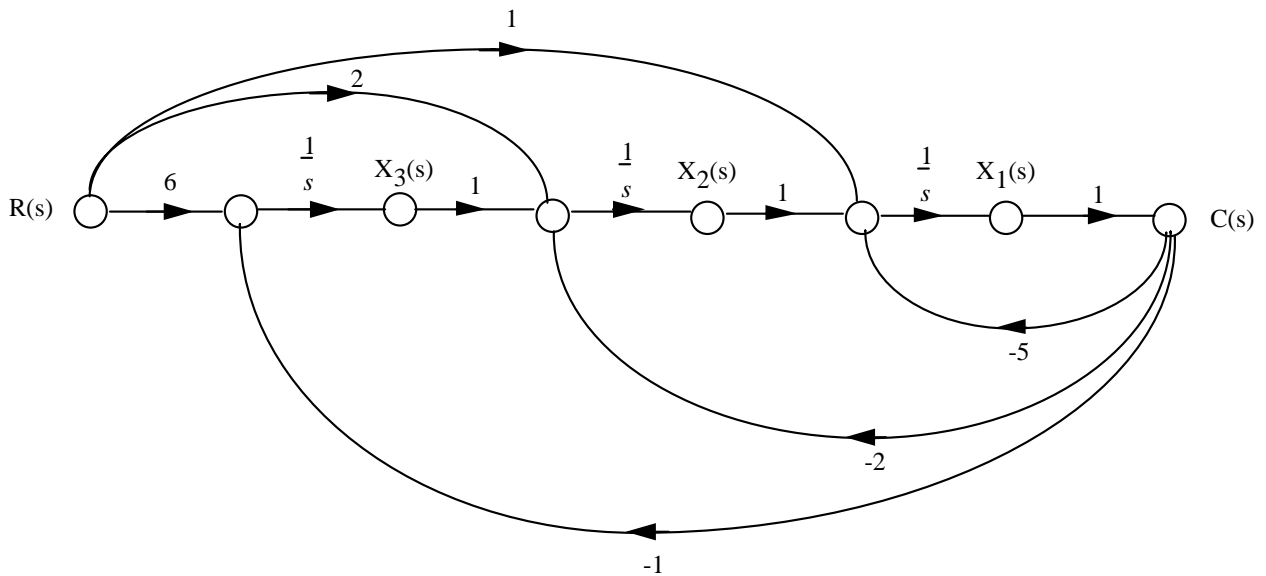

Writing the state and output equations,

$$\begin{aligned} \dot{x}_1 &= -5x_1 + x_2 + r \\ \dot{x}_2 &= -2x_1 + x_3 + 2r \\ \dot{x}_3 &= -x_1 + 6r \\ y &= [1 \quad 0 \quad 0] \mathbf{x} \end{aligned}$$

In vector-matrix form,

$$\dot{\mathbf{x}} = \begin{bmatrix} -5 & 1 & 0 \\ -2 & 0 & 1 \\ -1 & 0 & 0 \end{bmatrix} \mathbf{x} + \begin{bmatrix} 1 \\ 2 \\ 6 \end{bmatrix} r$$

$$y = [1 \quad 0 \quad 0] \mathbf{x}$$

**c.** Controller canonical form:

From the phase-variable form in Problem 5.31(c), reverse the order of the state variables and obtain,

$$\begin{aligned} \dot{x}_4 &= x_3 \\ \dot{x}_3 &= x_2 \\ \dot{x}_2 &= x_1 \\ \dot{x}_1 &= -4x_4 - 6x_3 - 5x_2 - 3x_1 + r \\ y &= x_4 + 7x_3 + 2x_2 + x_1 \end{aligned}$$

Putting the equations in order,

$$\begin{aligned} \dot{x}_1 &= -3x_1 - 5x_2 - 6x_3 - 4x_4 + r \\ \dot{x}_2 &= x_1 \\ \dot{x}_3 &= x_2 \\ \dot{x}_4 &= x_3 \\ y &= x_1 + 2x_2 + 7x_3 + x_4 \end{aligned}$$

In vector-matrix form,

$$\dot{\mathbf{x}} = \begin{bmatrix} -3 & -5 & -6 & -4 \\ 1 & 0 & 0 & 0 \\ 0 & 1 & 0 & 0 \\ 0 & 0 & 1 & 0 \end{bmatrix} \mathbf{x} + \begin{bmatrix} 1 \\ 0 \\ 0 \\ 0 \end{bmatrix} r$$

$$y = [1 \quad 2 \quad 7 \quad 1] \mathbf{x}$$

Observer canonical form:

$$G(s) = \frac{s^3 + 2s^2 + 7s + 1}{s^4 + 3s^3 + 5s^2 + 6s + 4} \cdot \text{Divide each term by } \frac{1}{s^2} \text{ and get}$$

$$G(s) = \frac{\frac{1}{s} + \frac{2}{s^2} + \frac{7}{s^3} + \frac{1}{s^4}}{1 + \frac{3}{s} + \frac{5}{s^2} + \frac{6}{s^3} + \frac{4}{s^4}} = \frac{C(s)}{R(s)}$$

Cross multiplying,

$$\left(\frac{1}{s} + \frac{2}{s^2} + \frac{7}{s^3} + \frac{1}{s^4}\right) R(s) = \left(1 + \frac{3}{s} + \frac{5}{s^2} + \frac{6}{s^3} + \frac{4}{s^4}\right) C(s)$$

Thus,

$$\frac{1}{s}(R(s) - 3C(s)) + \frac{1}{s^2}(2R(s) - 5C(s)) + \frac{1}{s^3}(7R(s) - 6C(s)) + \frac{1}{s^4}(R(s) - 4C(s)) = C(s)$$

Drawing the signal-flow graph,

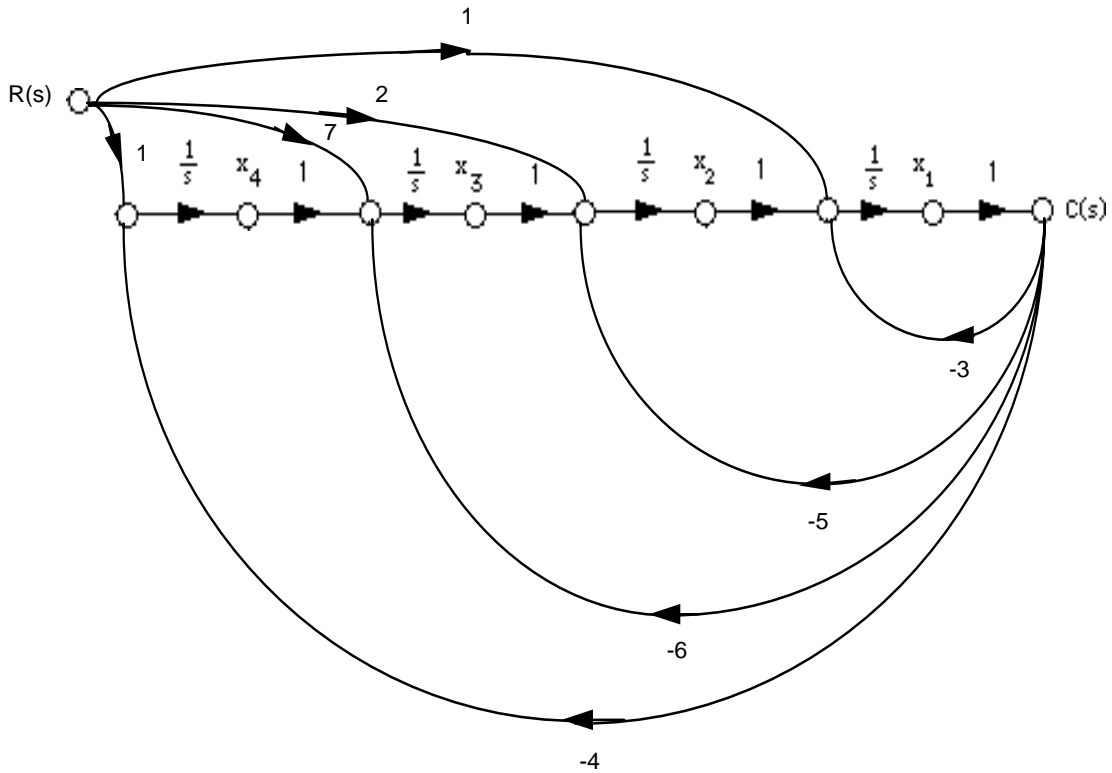

Writing the state and output equations,

$$\dot{x}_1 = -3x_1 + x_2 + r$$

$$\dot{x}_2 = -5x_1 + x_3 + 2r$$

$$\dot{x}_3 = -6x_1 + x_4 + 7r$$

$$\dot{x}_4 = -4x_1 + r$$

$$y = x_1$$

In vector matrix form,

$$\dot{\mathbf{x}} = \begin{bmatrix} -3 & 1 & 0 & 0 \\ -5 & 0 & 1 & 0 \\ -6 & 0 & 0 & 1 \\ -4 & 0 & 0 & 0 \end{bmatrix} \mathbf{x} + \begin{bmatrix} 1 \\ 2 \\ 7 \\ 1 \end{bmatrix} r$$

$$y = \begin{bmatrix} 1 & 0 & 0 & 0 \end{bmatrix} \mathbf{x}$$

33.

a.

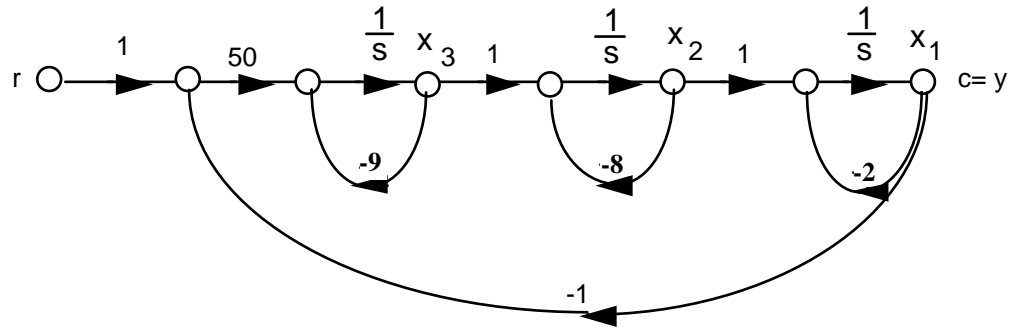

Writing the state equations,

$$\begin{aligned} \dot{x}_1 &= -2x_1 + x_2 \\ \dot{x}_2 &= -8x_2 + x_3 \\ \dot{x}_3 &= -50x_1 - 9x_3 + 50r \\ y &= x_1 \end{aligned}$$

In vector-matrix form,

$$\dot{\mathbf{x}} = \begin{bmatrix} -2 & 1 & 0 \\ 0 & -8 & 1 \\ -50 & 0 & -9 \end{bmatrix} \mathbf{x} + \begin{bmatrix} 0 \\ 0 \\ 50 \end{bmatrix} r$$

$$y = \begin{bmatrix} 1 & 0 & 0 \end{bmatrix} \mathbf{x}$$

b.

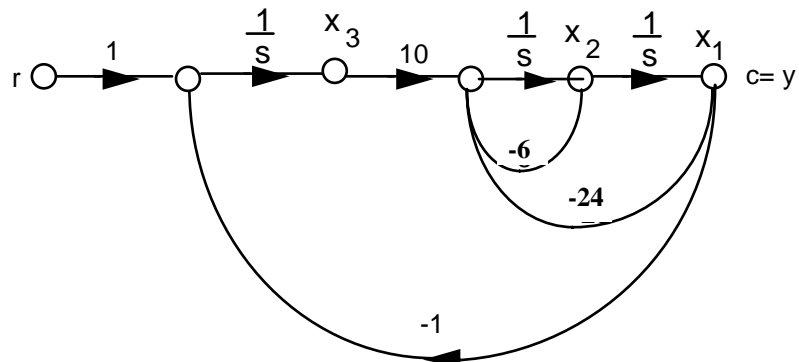

Writing the state equations,

$$\begin{aligned}\dot{x}_1 &= x_2 \\ \dot{x}_2 &= -24x_1 - 6x_2 + 10x_3 \\ \dot{x}_3 &= -x_1 + r \\ y &= x_1\end{aligned}$$

In vector-matrix form,

$$\begin{aligned}\dot{\mathbf{x}} &= \begin{bmatrix} 0 & 1 & 0 \\ -24 & -6 & 10 \\ -1 & 0 & 0 \end{bmatrix} \mathbf{x} + \begin{bmatrix} 0 \\ 0 \\ 1 \end{bmatrix} r \\ y &= [1 \ 0 \ 0] \mathbf{x}\end{aligned}$$

c.

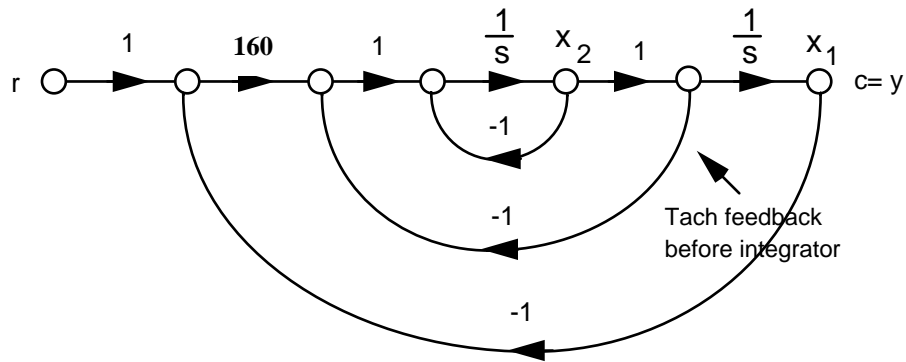

$$\begin{aligned}\dot{x}_1 &= x_2 \\ \dot{x}_2 &= -x_2 - x_2 + 160(r - x_1) = -160x_1 - 2x_2 + 160r \\ y &= x_1\end{aligned}$$

In vector-matrix form,

$$\begin{aligned}\dot{\mathbf{x}} &= \begin{bmatrix} 0 & 1 \\ -160 & -2 \end{bmatrix} \mathbf{x} + \begin{bmatrix} 0 \\ -160 \end{bmatrix} r \\ y &= [1 \ 0] \mathbf{x}\end{aligned}$$

d. Since  $\frac{1}{(s+1)^2} = \frac{1}{s^2+2s+1}$ , we draw the signal-flow as follows:

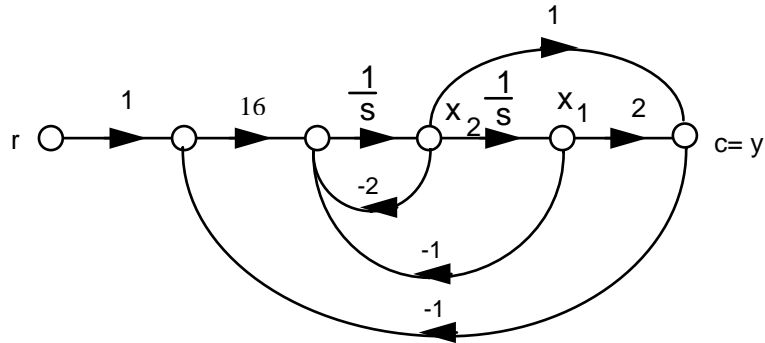

Writing the state equations,

$$\dot{x}_1 = x_2$$

$$\dot{x}_2 = -x_1 - 2x_2 + 16(r-c) = -x_1 - 2x_2 + 16(r - (2x_1+x_2)) = -33x_1 - 18x_2 + 16r$$

$$y = 2x_1 + x_2$$

In vector-matrix form,

$$\dot{\mathbf{x}} = \begin{bmatrix} 0 & 1 \\ -33 & -18 \end{bmatrix} \mathbf{x} + \begin{bmatrix} 0 \\ 16 \end{bmatrix} r$$

$$\dot{y} = [2 \quad 1] \mathbf{x}$$

34.

a. Phase-variable form:

$$T(s) = \frac{10}{s^3+3s^2+2s+10}$$

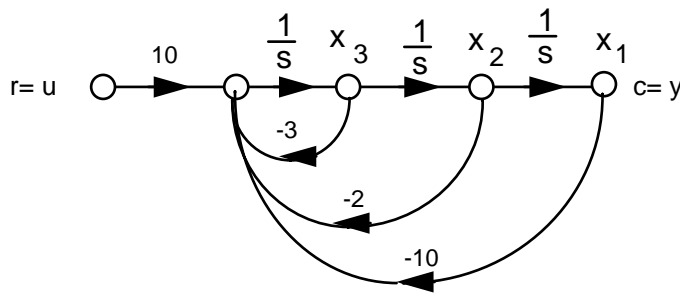

Writing the state equations,

$$\dot{x}_1 = x_2$$

$$\dot{x}_2 = x_3$$

$$\dot{x}_3 = -10x_1 - 2x_2 - 3x_3 + 10u$$

$$y = x_1$$

In vector-matrix form,

$$\dot{\mathbf{x}} = \begin{bmatrix} 0 & 1 & 0 \\ 0 & 0 & 1 \\ -10 & -2 & -3 \end{bmatrix} \mathbf{x} + \begin{bmatrix} 0 \\ 0 \\ 10 \end{bmatrix} u$$

$$y = [1 \ 0 \ 0] \mathbf{x}$$

b. Parallel form:

$$G(s) = \frac{5}{s} + \frac{-10}{s+1} + \frac{5}{s+2}$$

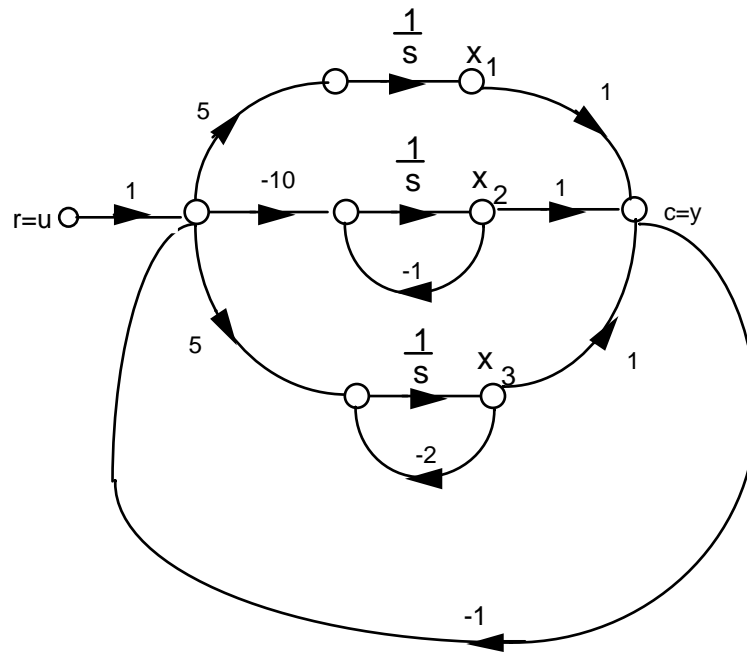

Writing the state equations,

$$\dot{x}_1 = 5(u - x_1 - x_2 - x_3) = -5x_1 - 5x_2 - 5x_3 + 5u$$

$$\dot{x}_2 = -10(u - x_1 - x_2 - x_3) - x_2 = 10x_1 + 9x_2 + 10x_3 - 10u$$

$$\dot{x}_3 = 5(u - x_1 - x_2 - x_3) - 2x_3 = -5x_1 - 5x_2 - 7x_3 + 5u$$

$$y = x_1 + x_2 + x_3$$

In vector-matrix form,

$$\dot{\mathbf{x}} = \begin{bmatrix} -5 & -5 & -5 \\ 10 & 9 & 10 \\ -5 & -5 & -7 \end{bmatrix} \mathbf{x} + \begin{bmatrix} 5 \\ -10 \\ 5 \end{bmatrix} u$$

$$y = [1 \ 1 \ 1] \mathbf{x}$$

35.

$$\text{a. } T(s) = \frac{10(s^2 + 5s + 6)}{s^4 + 16s^3 + 99s^2 + 244s + 180}$$

Drawing the signal-flow diagram,

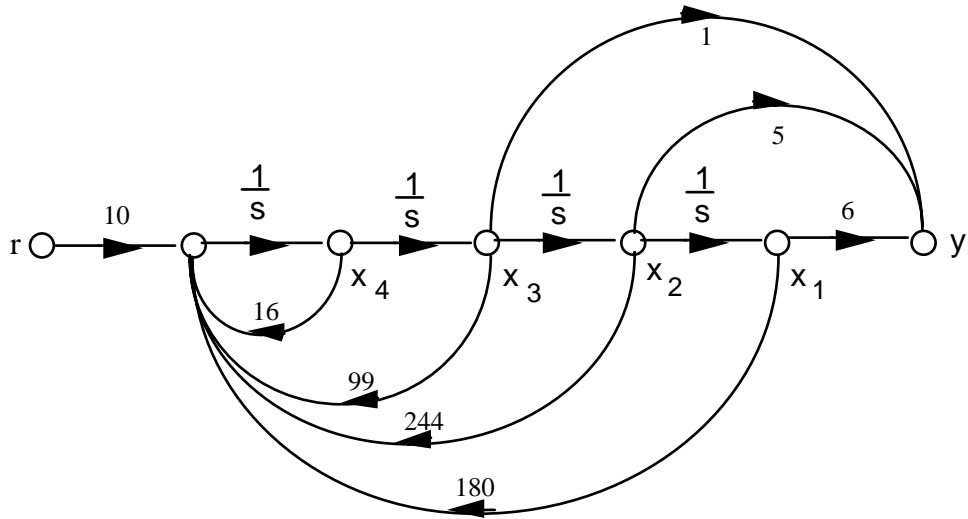

Writing the state and output equations,

$$\begin{aligned} \dot{x}_1 &= x_2 \\ \dot{x}_2 &= x_3 \\ \dot{x}_3 &= x_4 \\ \dot{x}_4 &= -180x_1 - 244x_2 - 99x_3 - 16x_4 + 10r \\ y &= 6x_1 + 5x_2 + x_3 \end{aligned}$$

In vector-matrix form,

$$\begin{aligned} \dot{\mathbf{x}} &= \begin{bmatrix} 0 & 1 & 0 & 0 \\ 0 & 0 & 1 & 0 \\ 0 & 0 & 0 & 1 \\ -180 & -244 & -99 & -16 \end{bmatrix} \mathbf{x} + \begin{bmatrix} 0 \\ 0 \\ 0 \\ 10 \end{bmatrix} r \\ y &= [6 \quad 5 \quad 1 \quad 0] \mathbf{x} \end{aligned}$$

b. 
$$G(s) = \frac{10(s+2)(s+3)}{(s+1)(s+4)(s+5)(s+6)} = \frac{1/3}{s+1} - \frac{10/3}{s+4} + \frac{15}{s+5} - \frac{12}{s+6}$$

Drawing the signal-flow diagram and including the unity-feedback path,



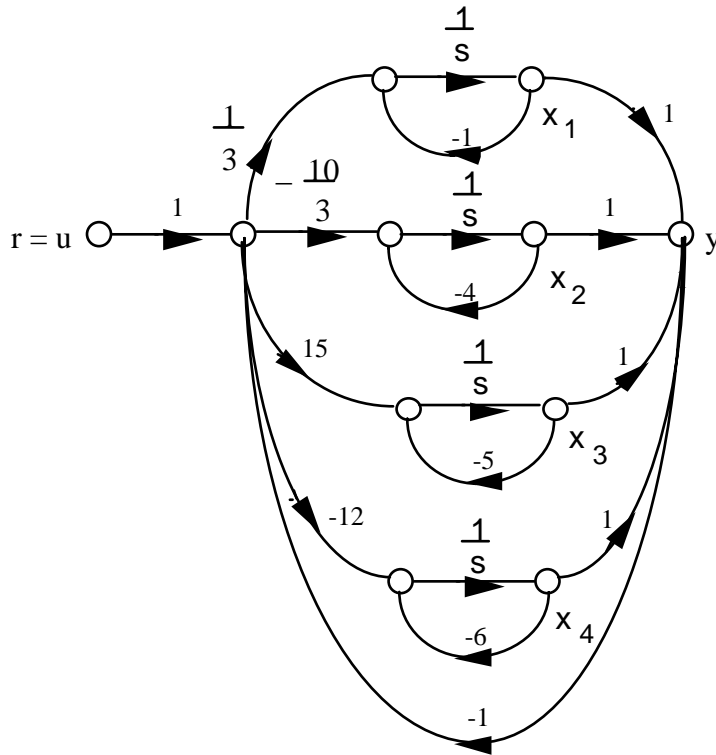

Writing the state and output equations,

$$\begin{aligned}\dot{x}_1 &= \frac{1}{3}(u - x_1 - x_2 - x_3 - x_4) - x_1 \\ \dot{x}_2 &= \frac{-10}{3}(u - x_1 - x_2 - x_3 - x_4) - 4x_2 \\ \dot{x}_3 &= 15(u - x_1 - x_2 - x_3 - x_4) - 5x_3 \\ \dot{x}_4 &= -12(u - x_1 - x_2 - x_3 - x_4) - 12x_4 \\ y &= x_1 + x_2 + x_3 + x_4\end{aligned}$$

In vector-matrix form,

$$\begin{aligned}\dot{\mathbf{x}} &= \begin{bmatrix} -\frac{4}{3} & -\frac{1}{3} & -\frac{1}{3} & -\frac{1}{3} \\ \frac{10}{3} & -\frac{2}{3} & \frac{10}{3} & \frac{10}{3} \\ \frac{3}{3} & \frac{3}{3} & \frac{3}{3} & \frac{3}{3} \\ -15 & -15 & -20 & -15 \\ 12 & 12 & 12 & 0 \end{bmatrix} \mathbf{x} + \begin{bmatrix} \frac{1}{3} \\ \frac{3}{3} \\ -\frac{10}{3} \\ \frac{3}{3} \\ -12 \end{bmatrix} u \\ y &= [1 \quad 1 \quad 1 \quad 1] \mathbf{x}\end{aligned}$$

36.

**Program:**

'(a)'

'G(s)'

G=zpk([-2 -3], [-1 -4 -5 -6], 10)

```

'T(s)'
T=feedback(G,1,-1)
[numt,dent]=tfdata(T,'v');
'Find controller canonical form'
[Acc,Bcc,Ccc,Dcc]=tf2ss(numt,dent)
A1=flipud(Acc);
'Transform to phase-variable form'
Apv=fliplr(A1)
Bpv=flipud(Bcc)
Cpv=fliplr(Ccc)
'(b)'
'G(s)'
G=zpk([-2 -3],[-1 -4 -5 -6],10)
'T(s)'
T=feedback(G,1,-1)
[numt,dent]=tfdata(T,'v');
'Find controller canonical form'
[Acc,Bcc,Ccc,Dcc]=tf2ss(numt,dent)
'Transform to modal form'
[A,B,C,D]=canon(Acc,Bcc,Ccc,Dcc,'modal')

```

**Computer response:**

ans =

(a)

ans =

G(s)

Zero/pole/gain:

10 (s+2) (s+3)

-----  
(s+1) (s+4) (s+5) (s+6)

ans =

T(s)

Zero/pole/gain:

10 (s+2) (s+3)

-----  
(s+1.264) (s+3.412) (s^2 + 11.32s + 41.73)

ans =

Find controller canonical form

Acc =

-16.0000	-99.0000	-244.0000	-180.0000
1.0000	0	0	0
0	1.0000	0	0
0	0	1.0000	0

Bcc =

1
0
0
0

Ccc =

0 10.0000 50.0000 60.0000

Dcc =

0

ans =

Transform to phase-variable form

Apv =

0 1.0000 0 0  
 0 0 1.0000 0  
 0 0 0 1.0000  
 -180.0000 -244.0000 -99.0000 -16.0000

Bpv =

0  
 0  
 0  
 1

Cpv =

60.0000 50.0000 10.0000 0

ans =

(b)

ans =

G(s)

Zero/pole/gain:

10 (s+2) (s+3)

-----  
 (s+1) (s+4) (s+5) (s+6)

ans =

T(s)

Zero/pole/gain:

10 (s+2) (s+3)

-----  
 (s+1.264) (s+3.412) (s^2 + 11.32s + 41.73)

ans =

Find controller canonical form

Acc =

-16.0000 -99.0000 -244.0000 -180.0000  
 1.0000 0 0 0  
 0 1.0000 0 0  
 0 0 1.0000 0

5-52 Chapter 5: Reduction of Multiple Subsystems

Bcc =

1  
0  
0  
0

Ccc =

0 10.0000 50.0000 60.0000

Dcc =

0

ans =

Transform to modal form

A =

-5.6618 3.1109 0 0  
-3.1109 -5.6618 0 0  
0 0 -3.4124 0  
0 0 0 -1.2639

B =

-4.1108  
1.0468  
1.3125  
0.0487

C =

0.1827 0.6973 -0.1401 4.2067

D =

0

37.

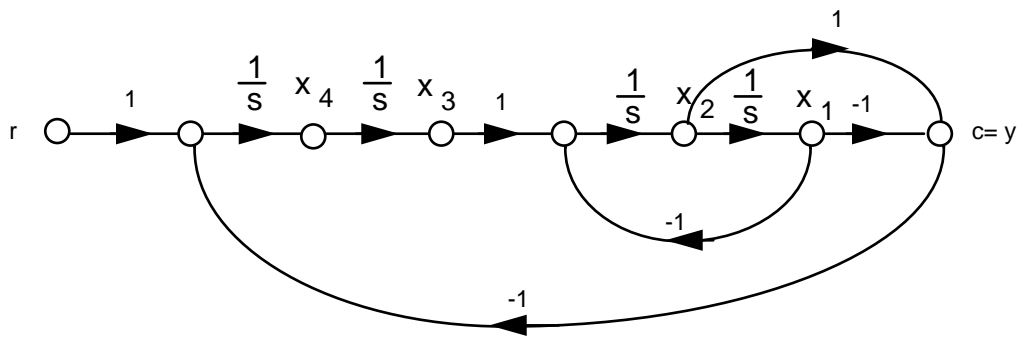

Writing the state equations,

$$\begin{aligned} \dot{x}_1 &= x_2 \\ \dot{x}_2 &= -x_1 + x_3 \\ \dot{x}_3 &= x_4 \\ \dot{x}_4 &= x_1 - x_2 + r \\ y &= -x_1 + x_2 \end{aligned}$$

In vector-matrix form,

$$\dot{\mathbf{x}} = \begin{bmatrix} 0 & 1 & 0 & 0 \\ -1 & 0 & 1 & 0 \\ 0 & 0 & 0 & 1 \\ 1 & -1 & 0 & 0 \end{bmatrix} \mathbf{x} + \begin{bmatrix} 0 \\ 0 \\ 0 \\ 1 \end{bmatrix} r$$

$$y = \mathbf{c} = [-1 \quad 1 \quad 0 \quad 0] \mathbf{x}$$

38.

a.

$$\ddot{\theta}_1 + 5\dot{\theta}_1 + 6\theta_1 - 3\dot{\theta}_2 - 4\theta_2 = 0$$

$$-3\dot{\theta}_1 - 4\theta_1 + \ddot{\theta}_2 + 5\dot{\theta}_2 + 5\theta_2 = T$$

or

$$\ddot{\theta}_1 = -5\dot{\theta}_1 - 6\theta_1 + 3\dot{\theta}_2 + 4\theta_2$$

$$\ddot{\theta}_2 = 3\dot{\theta}_1 + 4\theta_1 - 5\dot{\theta}_2 - 5\theta_2 + T$$

Letting,  $\theta_1 = x_1$ ;  $\dot{\theta}_1 = x_2$ ;  $\theta_2 = x_3$ ;  $\dot{\theta}_2 = x_4$ ,

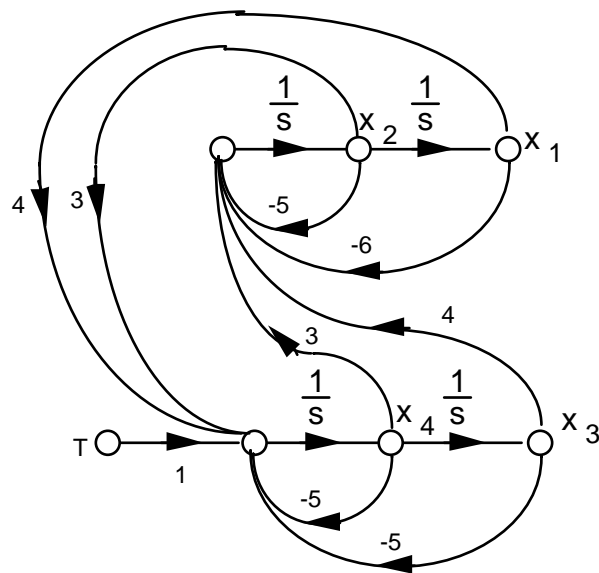

where  $\mathbf{x} = \boldsymbol{\theta}$ .

**b.** Using the signal-flow diagram,

$$\begin{aligned}\dot{x}_1 &= x_2 \\ \dot{x}_2 &= -6x_1 - 5x_2 + 4x_3 + 3x_4 \\ \dot{x}_3 &= x_4 \\ \dot{x}_4 &= 4x_1 + 3x_2 - 5x_3 - 5x_4 + T \\ y &= x_3\end{aligned}$$

In vector-matrix form,

$$\dot{\mathbf{x}} = \begin{bmatrix} 0 & 1 & 0 & 0 \\ -6 & -5 & 4 & 3 \\ 0 & 0 & 0 & 1 \\ 4 & 3 & -5 & -5 \end{bmatrix} \mathbf{x} + \begin{bmatrix} 0 \\ 0 \\ 0 \\ 1 \end{bmatrix} T$$

$$y = [0 \quad 0 \quad 1 \quad 0] \mathbf{x}$$

**39.**

**Program:**

```
numg=7;
deng=poly([0 -9 -12]);
G=tf(numg,deng);
T=feedback(G,1)
[numt,dent]=tfdata(T,'v')
[A,B,C,D]=tf2ss(numt,dent); %Obtain controller canonical form
'(a)' %Display label
A=flipud(A); %Convert to phase-variable form
A=fliplr(A) %Convert to phase-variable form
B=flipud(B) %Convert to phase-variable form
C=fliplr(C) %Convert to phase-variable form
'(b)' %Display label
[a,b,c,d]=canon(A,B,C,D) %Convert to parallel form
```

**Computer response:**

```
Transfer function:
          7
-----
s^3 + 21 s^2 + 108 s + 7

numt =

    0    0    0    7

dent =

    1    21   108    7
```

ans =

(a)

A =

$$\begin{bmatrix} 0 & 1 & 0 \\ 0 & 0 & 1 \\ -7 & -108 & -21 \end{bmatrix}$$

B =

$$\begin{bmatrix} 0 \\ 0 \\ 1 \end{bmatrix}$$

C =

$$\begin{bmatrix} 7 & 0 & 0 \end{bmatrix}$$

ans =

(b)

a =

$$\begin{bmatrix} -0.0657 & 0 & 0 \\ 0 & -12.1807 & 0 \\ 0 & 0 & -8.7537 \end{bmatrix}$$

b =

$$\begin{bmatrix} -0.0095 \\ -3.5857 \\ 2.5906 \end{bmatrix}$$

c =

$$\begin{bmatrix} -6.9849 & -0.0470 & -0.0908 \end{bmatrix}$$

d =

$$0$$

**40.**

$$\dot{\mathbf{x}}_1 = \mathbf{A}_1 \mathbf{x}_1 + \mathbf{B}_1 \mathbf{r} \quad (1)$$

$$y_1 = \mathbf{C}_1 \mathbf{x}_1 \quad (2)$$

$$\dot{\mathbf{x}}_2 = \mathbf{A}_2 \mathbf{x}_2 + \mathbf{B}_2 y_1 \quad (3)$$

$$y_2 = \mathbf{C}_2 \mathbf{x}_2 \quad (4)$$

Substituting Eq. (2) into Eq. (3),

$$\dot{\mathbf{x}}_1 = \mathbf{A}_1 \mathbf{x}_1 + \mathbf{B}_1 \mathbf{r}$$

$$\dot{\mathbf{x}}_2 = \mathbf{B}_2\mathbf{C}_1\mathbf{x}_1 + \mathbf{A}_2\mathbf{x}_2$$

$$y_2 = \mathbf{C}_2\mathbf{x}_2$$

In vector-matrix notation,

$$\begin{bmatrix} \dot{\mathbf{x}}_1 \\ \dot{\mathbf{x}}_2 \end{bmatrix} = \begin{bmatrix} \mathbf{A}_1 & \mathbf{O} \\ \mathbf{B}_2\mathbf{C}_1 & \mathbf{A}_2 \end{bmatrix} \begin{bmatrix} \mathbf{x}_1 \\ \mathbf{x}_2 \end{bmatrix} + \begin{bmatrix} \mathbf{B}_1 \\ \mathbf{O} \end{bmatrix} \mathbf{r}$$

$$\mathbf{y}_2 = [\mathbf{O} \quad \mathbf{C}_2] \begin{bmatrix} \mathbf{x}_1 \\ \mathbf{x}_2 \end{bmatrix}$$

41.

$$\dot{\mathbf{x}}_1 = \mathbf{A}_1\mathbf{x}_1 + \mathbf{B}_1\mathbf{r} \tag{1}$$

$$y_1 = \mathbf{C}_1\mathbf{x}_1 \tag{2}$$

$$\dot{\mathbf{x}}_2 = \mathbf{A}_2\mathbf{x}_2 + \mathbf{B}_2\mathbf{r} \tag{3}$$

$$y_2 = \mathbf{C}_2\mathbf{x}_2 \tag{4}$$

In vector-matrix form,

$$\begin{bmatrix} \dot{\mathbf{x}}_1 \\ \dot{\mathbf{x}}_2 \end{bmatrix} = \begin{bmatrix} \mathbf{A}_1 & \mathbf{O} \\ \mathbf{O} & \mathbf{A}_2 \end{bmatrix} \begin{bmatrix} \mathbf{x}_1 \\ \mathbf{x}_2 \end{bmatrix} + \begin{bmatrix} \mathbf{B}_1 \\ \mathbf{B}_2 \end{bmatrix} \mathbf{r}$$

$$\mathbf{y} = \mathbf{y}_1 + \mathbf{y}_2 = [\mathbf{C}_1 \quad \mathbf{C}_2] \begin{bmatrix} \mathbf{x}_1 \\ \mathbf{x}_2 \end{bmatrix}$$

42.

$$\dot{\mathbf{x}}_1 = \mathbf{A}_1\mathbf{x}_1 + \mathbf{B}_1\mathbf{e} \tag{1}$$

$$y = \mathbf{C}_1\mathbf{x}_1 \tag{2}$$

$$\dot{\mathbf{x}}_2 = \mathbf{A}_2\mathbf{x}_2 + \mathbf{B}_2y \tag{3}$$

$$p = \mathbf{C}_2\mathbf{x}_2 \tag{4}$$

Substituting  $\mathbf{e} = \mathbf{r} - p$  into Eq. (1) and substituting Eq. (2) into (3), we obtain,

$$\dot{\mathbf{x}}_1 = \mathbf{A}_1\mathbf{x}_1 + \mathbf{B}_1(\mathbf{r} - p) \tag{5}$$

$$y = \mathbf{C}_1\mathbf{x}_1 \tag{6}$$

$$\dot{\mathbf{x}}_2 = \mathbf{A}_2\mathbf{x}_2 + \mathbf{B}_2\mathbf{C}_1\mathbf{x}_1 \tag{7}$$

$$p = \mathbf{C}_2\mathbf{x}_2 \tag{8}$$

Substituting Eq. (8) into Eq. (5),

$$\dot{\mathbf{x}}_1 = \mathbf{A}_1\mathbf{x}_1 - \mathbf{B}_1\mathbf{C}_2\mathbf{x}_2 + \mathbf{B}_1\mathbf{r}$$



$$\dot{\mathbf{x}}_2 = \mathbf{B}_2 \mathbf{C}_1 \mathbf{x}_1 + \mathbf{A}_2 \mathbf{x}_2$$

$$\mathbf{y} = \mathbf{C}_1 \mathbf{x}_1$$

In vector-matrix form,

$$\begin{bmatrix} \dot{\mathbf{x}}_1 \\ \dot{\mathbf{x}}_2 \end{bmatrix} = \begin{bmatrix} \mathbf{A}_1 & \mathbf{B}_1 \mathbf{C}_2 \\ \mathbf{B}_2 \mathbf{C}_1 & \mathbf{A}_2 \end{bmatrix} \begin{bmatrix} \mathbf{x}_1 \\ \mathbf{x}_2 \end{bmatrix} + \begin{bmatrix} \mathbf{B}_1 \\ \mathbf{0} \end{bmatrix} \mathbf{r}$$

$$\mathbf{y} = [\mathbf{C}_1 \quad \mathbf{0}] \begin{bmatrix} \mathbf{x}_1 \\ \mathbf{x}_2 \end{bmatrix}$$

43.

$$\dot{\mathbf{z}} = \mathbf{P}^{-1} \mathbf{A} \mathbf{P} \mathbf{z} + \mathbf{P}^{-1} \mathbf{B} u$$

$$\mathbf{y} = \mathbf{C} \mathbf{P} \mathbf{z}$$

$$\mathbf{P}^{-1} = \begin{bmatrix} -4 & 9 & -3 \\ 0 & -4 & 7 \\ -1 & -4 & -9 \end{bmatrix}; \quad \therefore \mathbf{P} = \begin{bmatrix} -0.2085 & -0.3029 & -0.1661 \\ 0.0228 & -0.1075 & -0.0912 \\ 0.0130 & 0.0814 & -0.0521 \end{bmatrix}$$

$$\mathbf{P}^{-1} \mathbf{A} \mathbf{P} = \begin{bmatrix} 18.5961 & 25.4756 & 5.6156 \\ -12.9023 & -28.8893 & -8.3909 \\ -0.5733 & 11.4169 & 5.2932 \end{bmatrix}; \quad \mathbf{P}^{-1} \mathbf{B} = \begin{bmatrix} -58 \\ 63 \\ -12 \end{bmatrix}; \quad \mathbf{C} \mathbf{P} = [1.5668 \quad 3.0423 \quad 2.7329]$$

44.

$$\dot{\mathbf{z}} = \mathbf{P}^{-1} \mathbf{A} \mathbf{P} \mathbf{z} + \mathbf{P}^{-1} \mathbf{B} u$$

$$\mathbf{y} = \mathbf{C} \mathbf{P} \mathbf{z}$$

$$\mathbf{P}^{-1} = \begin{bmatrix} 5 & -4 & 9 \\ 6 & -7 & 6 \\ 6 & -5 & -3 \end{bmatrix}; \quad \mathbf{P} = \begin{bmatrix} 0.3469 & -0.3878 & 0.2653 \\ 0.3673 & -0.4694 & 0.1633 \\ 0.0816 & 0.0068 & -0.0748 \end{bmatrix}$$

$$\mathbf{P}^{-1} \mathbf{A} \mathbf{P} = \begin{bmatrix} -28.2857 & 40.8095 & -40.9048 \\ -18.3061 & 28.2245 & -37.4694 \\ 5.3878 & -6.5510 & -5.9388 \end{bmatrix}; \quad \mathbf{P}^{-1} \mathbf{B} = \begin{bmatrix} 61 \\ 82 \\ 74 \end{bmatrix}; \quad \mathbf{C} \mathbf{P} = [-2.0816 \quad 2.6599 \quad -1.2585]$$

45.

Eigenvalues are -1, -2, and -3 since,

$$|\lambda \mathbf{I} - \mathbf{A}| = (\lambda + 3)(\lambda + 2)(\lambda + 1)$$

Solving for the eigenvectors,  $\mathbf{A} \mathbf{x} = \lambda \mathbf{x}$

or,

$$\begin{aligned}4x_3 - 5x_2 - (\lambda + 5)x_1 &= 0 \\ -2x_3 - x_2\lambda + 2x_1 &= 0 \\ -2x_2 - (\lambda + 1)x_3 &= 0\end{aligned}$$

For  $\lambda = -1$ ,  $x_2 = 0$ ,  $x_1 = x_3$ . For  $\lambda = -2$ ,  $x_1 = x_2 = \frac{x_3}{2}$ . For  $\lambda = -3$ ,  $x_1 = -\frac{x_2}{2}$ ,  $x_2 = x_3$ . Thus,

$\dot{\mathbf{z}} = \mathbf{P}^{-1}\mathbf{A}\mathbf{P}\mathbf{z} + \mathbf{P}^{-1}\mathbf{B}\mathbf{u}$ ;  $\mathbf{y} = \mathbf{C}\mathbf{P}\mathbf{z}$ , where

$$\mathbf{P}^{-1}\mathbf{A}\mathbf{P} = \begin{pmatrix} -1 & 0 & 0 \\ 0 & -2 & 0 \\ 0 & 0 & -3 \end{pmatrix}; \quad \mathbf{P}^{-1}\mathbf{B} = \begin{pmatrix} -12 \\ 8 \\ -3 \end{pmatrix}; \quad \mathbf{C}\mathbf{P} = (1, 4, 7)$$

46.

Eigenvalues are 1, -2, and 3 since,

$$|\lambda\mathbf{I} - \mathbf{A}| = (\lambda - 3)(\lambda + 2)(\lambda - 1)$$

Solving for the eigenvectors,  $\mathbf{A}\mathbf{x} = \lambda\mathbf{x}$

or,

$$\begin{aligned}(-\lambda - 10)x_1 + 7x_3 - 3x_2 &= 0 \\ \frac{73}{4}x_1 + \left(-\lambda + \frac{25}{4}\right)x_2 - \frac{47}{4}x_3 &= 0 \\ -\frac{29}{4}x_1 - \frac{9}{4}x_2 + \left(-\lambda + \frac{23}{4}\right)x_3 &= 0\end{aligned}$$

For  $\lambda = 1$ ,  $x_1 = x_2 = \frac{x_3}{2}$ . For  $\lambda = -2$ ,  $x_1 = 2x_3$ ,  $x_2 = -3x_3$ . For  $\lambda = 3$ ,  $x_1 = x_3$ ,  $x_2 = -2x_3$ . Thus,

$\dot{\mathbf{z}} = \mathbf{P}^{-1}\mathbf{A}\mathbf{P}\mathbf{z} + \mathbf{P}^{-1}\mathbf{B}\mathbf{u}$ ;  $\mathbf{y} = \mathbf{C}\mathbf{P}\mathbf{z}$ , where

$$\mathbf{P}^{-1}\mathbf{A}\mathbf{P} = \begin{pmatrix} 1 & 0 & 0 \\ 0 & -2 & 0 \\ 0 & 0 & 3 \end{pmatrix}; \quad \mathbf{P}^{-1}\mathbf{B} = \begin{pmatrix} \frac{3}{2} \\ \frac{1}{2} \\ -\frac{3}{2} \end{pmatrix}; \quad \mathbf{C}\mathbf{P} = (7, 12, 9)$$

47.

**Program:**

```
A=[-10 -3 7;18.25 6.25 -11.75;-7.25 -2.25 5.75];
B=[1;3;2];
C=[1 -2 4];
[P,d]=eig(A);
Ad=inv(P)*A*P;
Bd=inv(P)*B;
Cd=C*P;
```

**Computer response:**

Ad =

-2.0000	0.0000	0.0000
-0.0000	3.0000	-0.0000
0.0000	0.0000	1.0000

Bd =

1.8708
-3.6742
3.6742

Cd =

3.2071	3.6742	2.8577
--------	--------	--------

48.

a. Combine  $G_1(s)$  and  $G_2(s)$ . Then push  $K_1$  to the right past the summing junction:

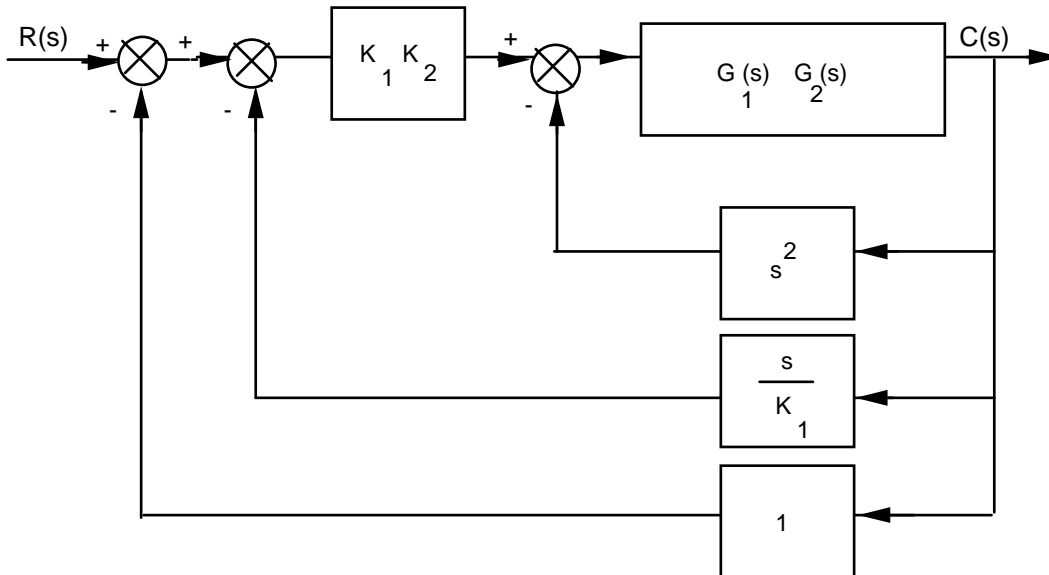

Push  $K_1 K_2$  to the right past the summing junction:

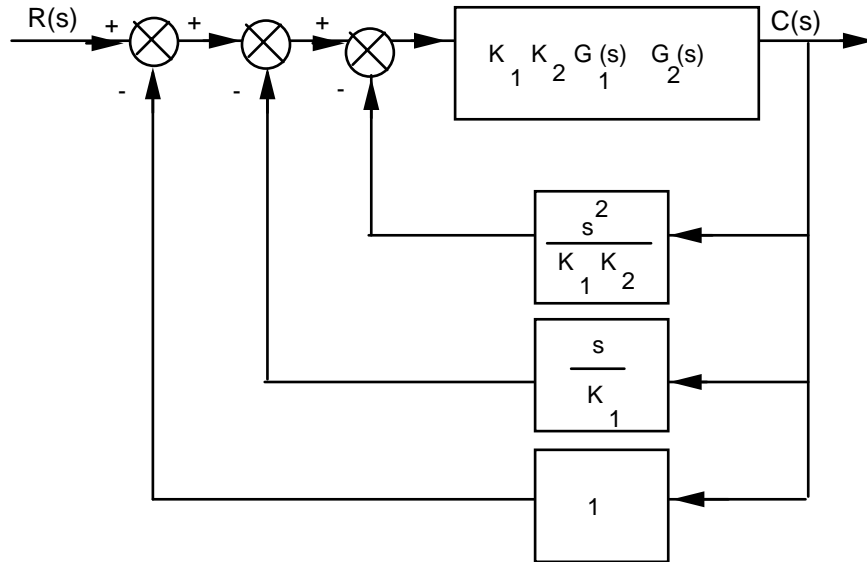

$$\text{Hence, } T(s) = \frac{K_1 K_2 G_1(s) G_2(s)}{1 + K_1 K_2 G_1(s) G_2(s) \left( 1 + \frac{s}{K_1} + \frac{s^2}{K_1 K_2} \right)}$$

b. Rearranging the block diagram to show commanded pitch rate as the input and actual pitch rate as the output:

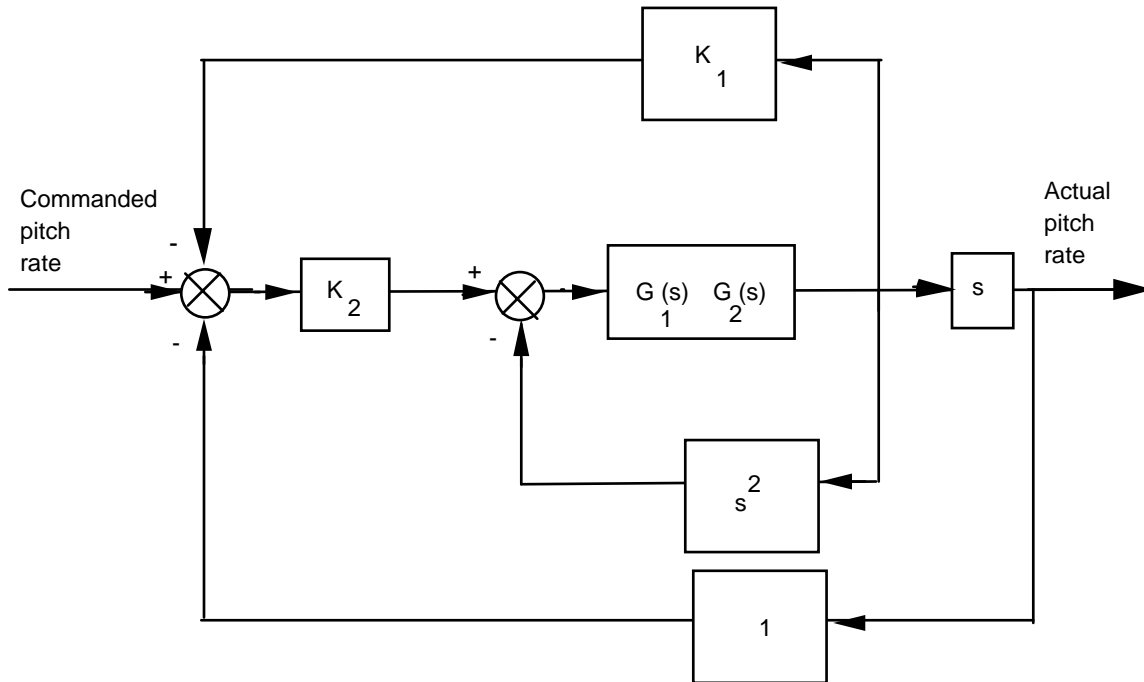

Pushing  $K_2$  to the right past the summing junction; and pushing  $s$  to the left past the pick-off point yields,

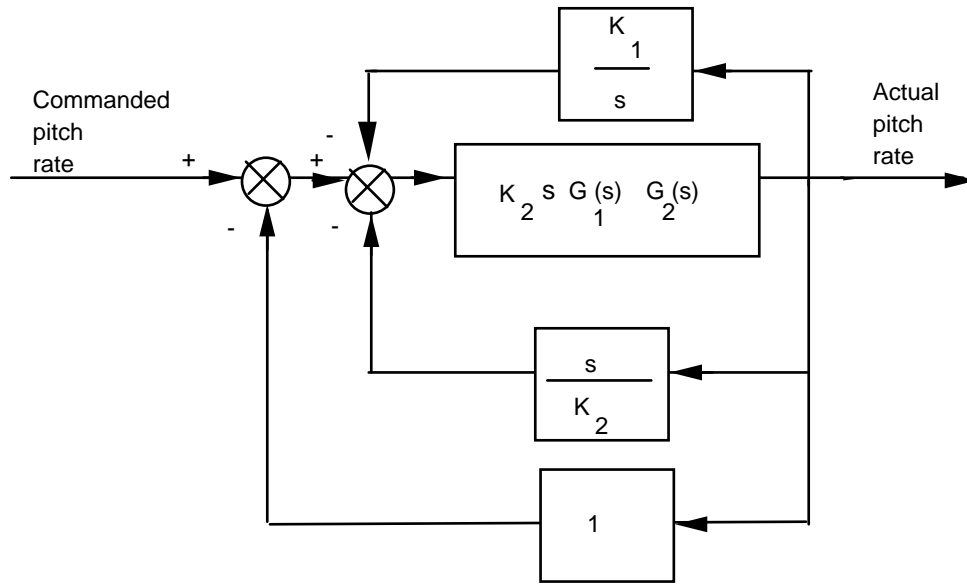

Finding the closed-loop transfer function:

$$T(s) = \frac{K_2 s G_1(s) G_2(s)}{1 + K_2 s G_1(s) G_2(s) \left( 1 + \frac{s}{K_2} + \frac{K_1}{s} \right)} = \frac{K_2 s G_1(s) G_2(s)}{1 + G_1(s) G_2(s) (s^2 + K_2 s + K_1 K_2)}$$

c. Rearranging the block diagram to show commanded pitch acceleration as the input and actual pitch acceleration as the output:

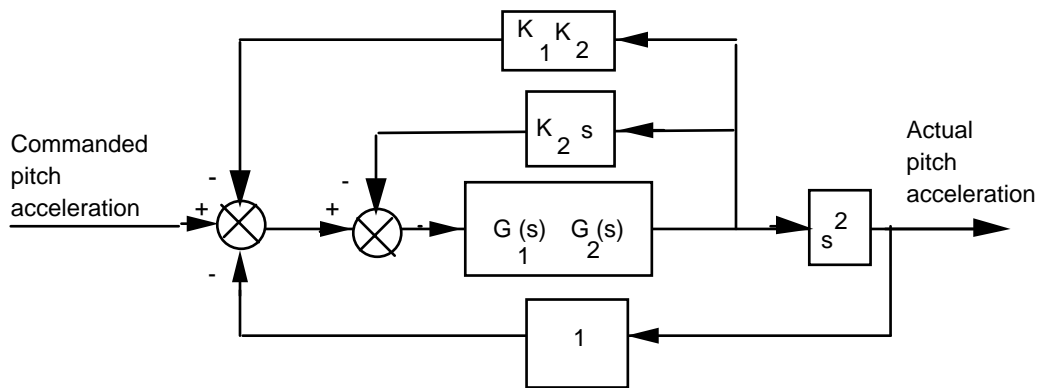

Pushing  $s^2$  to the left past the pick-off point yields,

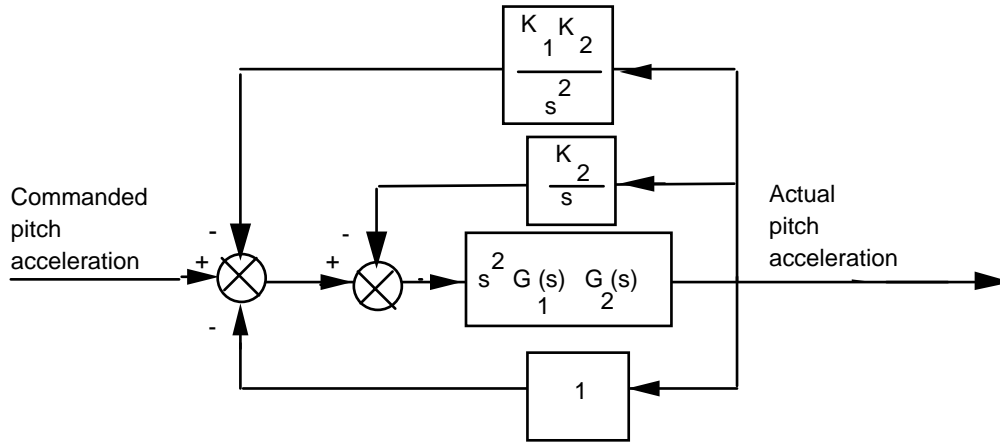

Finding the closed-loop transfer function:

$$T(s) = \frac{s^2 G_1(s) G_2(s)}{1 + s^2 G_1(s) G_2(s) \left( 1 + \frac{K_1 K_2}{s^2} + \frac{K_2}{s} \right)} = \frac{s^2 G_1(s) G_2(s)}{1 + G_1(s) G_2(s) (s^2 + K_2 s + K_1 K_2)}$$

49.

Establish a sinusoidal model for the carrier:  $T(s) = \frac{K_1}{s^2 + a^2}$

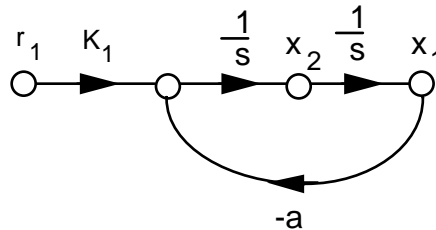

Establish a sinusoidal model for the message:  $T(s) = \frac{K_2}{s^2 + b^2}$

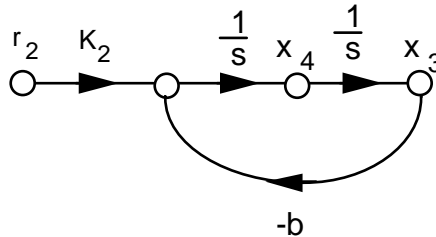

Writing the state equations,

$$\begin{aligned} \dot{x}_1 &= x_2 \\ \dot{x}_2 &= -a^2x_1 + K_1r \\ \dot{x}_3 &= x_4 \\ \dot{x}_4 &= -b^2x_3 + K_2r \\ y &= x_1x_3 \end{aligned}$$

50.

The equivalent forward transfer function is  $G(s) = \frac{K_1K_2}{s(s+a_1)}$ . The equivalent feedback transfer function is

$H(s) = K_3 + \frac{K_4s}{s+a_2}$ . Hence, the closed-loop transfer function is

$$T(s) = \frac{G(s)}{1 + G(s)H(s)} = \frac{K_1K_2(s+a_2)}{s^3 + (a_1+a_2)s^2 + (a_1a_2+K_1K_2K_3+K_1K_2K_4)s + K_1K_2K_3a_2}$$

51.

a. The equivalent forward transfer function is

$$G_e(s) = K \frac{\frac{5}{s(s+2)}}{1 + \frac{5}{s(s+2)}} \frac{1}{s(s+3)} = \frac{5K}{s(s+3)(s^2+2s+5)}$$

$$T(s) = \frac{G_e}{1+G_e} = \frac{5K}{s^4+5s^3+11s^2+15s+5K}$$

b. Draw the signal-flow diagram:

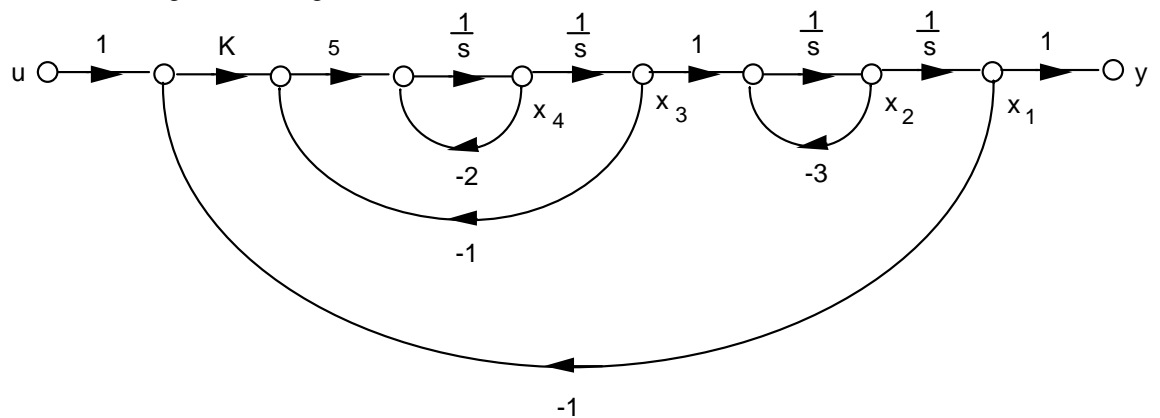

Writing the state and output equations from the signal-flow diagram:

$$\begin{aligned}\dot{x}_1 &= x_2 \\ \dot{x}_2 &= -3x_2 + x_3 \\ \dot{x}_3 &= x_4 \\ \dot{x}_4 &= -5Kx_1 - 5x_3 - 2x_4 + 5Ku \\ y &= x_1\end{aligned}$$

In vector-matrix form:

$$\dot{\mathbf{x}} = \begin{bmatrix} 0 & 1 & 0 & 0 \\ 0 & -3 & 1 & 0 \\ 0 & 0 & 0 & 1 \\ -5K & 0 & -5 & -2 \end{bmatrix} \mathbf{x} + \begin{bmatrix} 0 \\ 0 \\ 0 \\ 5K \end{bmatrix} u$$

$$y = [1 \ 0 \ 0 \ 0] \mathbf{x}$$

c.

**Program:**

```
for K=1:1:5
    numt=5*K;
    dent=[1 5 11 15 5*K];
    T=tf(numt,dent);
    hold on;
    subplot(2,3,K);
    step(T,0:0.01:20)
    title(['K=',int2str(K)])
end
```

**Computer response:**



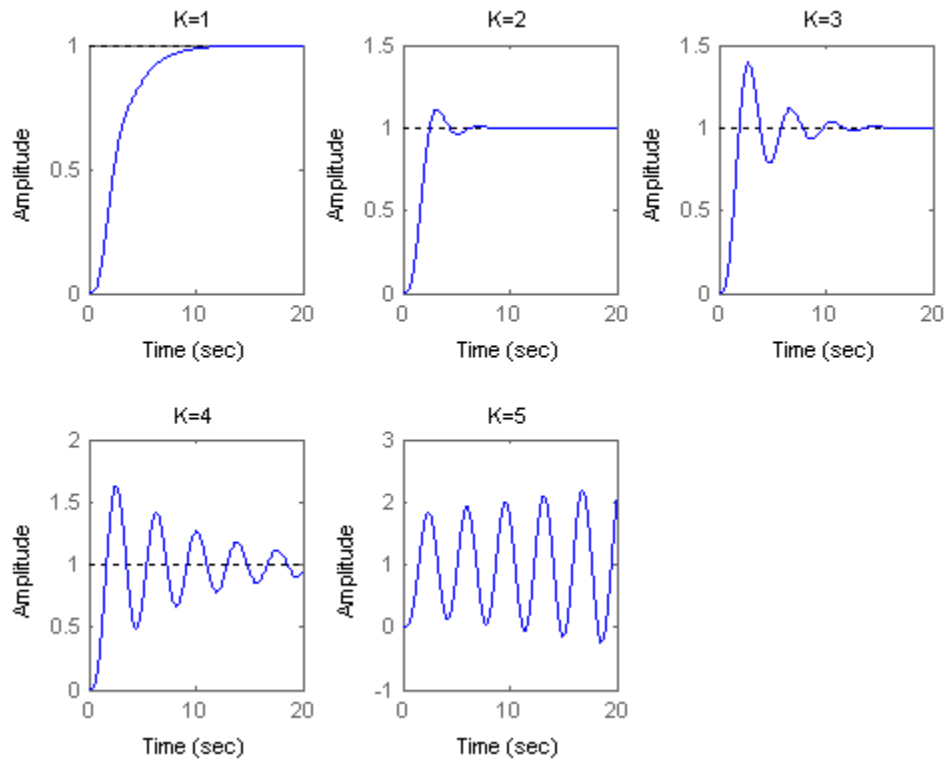

52.

a. Draw the signal-flow diagram:

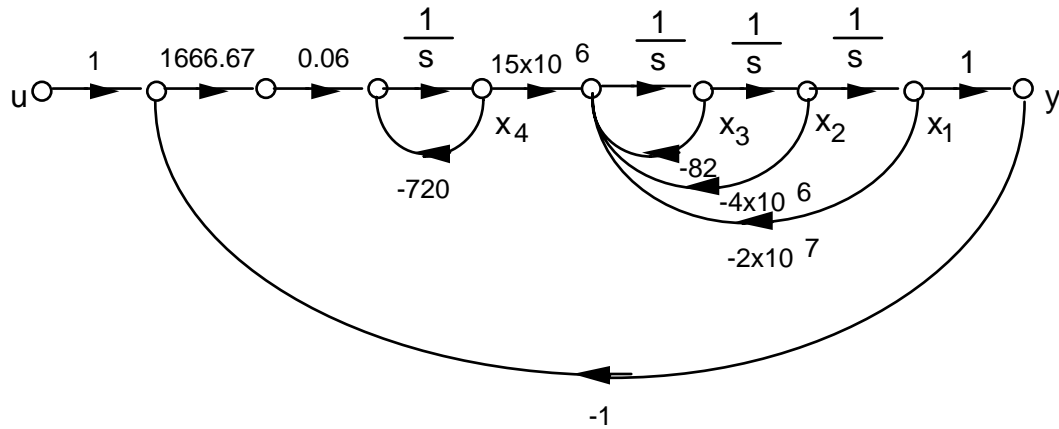

Write state and output equations from the signal-flow diagram:

$$\dot{x}_1 = x_2$$

$$\dot{x}_2 = x_3$$

$$\dot{x}_3 = -2 \times 10^7 x_1 - 4 \times 10^6 x_2 - 82 x_3 + 15 \times 10^6 x_4$$

$$\dot{x}_4 = -100 x_1 - 720 x_4 + 100 u$$

$$y = x_1$$

In vector-matrix form:

$$\dot{\mathbf{x}} = \begin{bmatrix} 0 & 1 & 0 & 0 \\ 0 & 0 & 1 & 0 \\ -2 \times 10^7 & -4 \times 10^6 & -82 & 15 \times 10^6 \\ -100 & 0 & 0 & -720 \end{bmatrix} \mathbf{x} + \begin{bmatrix} 0 \\ 0 \\ 0 \\ 100 \end{bmatrix} u$$

$$y = [1 \ 0 \ 0 \ 0] \mathbf{x}$$

**b.**

**Program:**

```
numg=1666.67*0.06*15e6;
deng=conv([1 720],[1 82 4e6 2e7]);
'G(s)'
G=tf(numg,deng)
'T(s)'
T=feedback(G,1)
step(T)
```

**Computer response:**

ans =

G(s)

Transfer function:

$$\frac{1.5e009}{s^4 + 802 s^3 + 4.059e006 s^2 + 2.9e009 s + 1.44e010}$$

ans =

T(s)

Transfer function:

$$\frac{1.5e009}{s^4 + 802 s^3 + 4.059e006 s^2 + 2.9e009 s + 1.59e010}$$

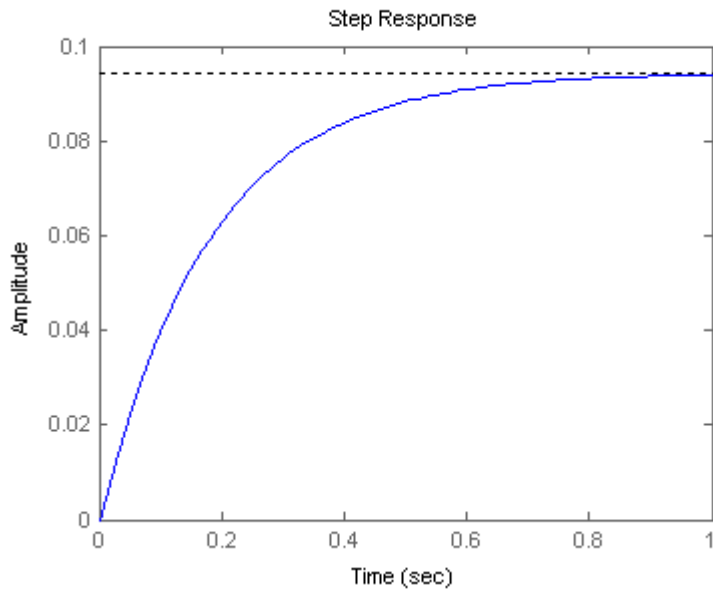

53.

a. Phase-variable form:  $G(s) = \frac{-272(s^2+1.9s+84)}{s^3+17.1s^2+34.58s-123.48}$

Drawing the signal-flow diagram:

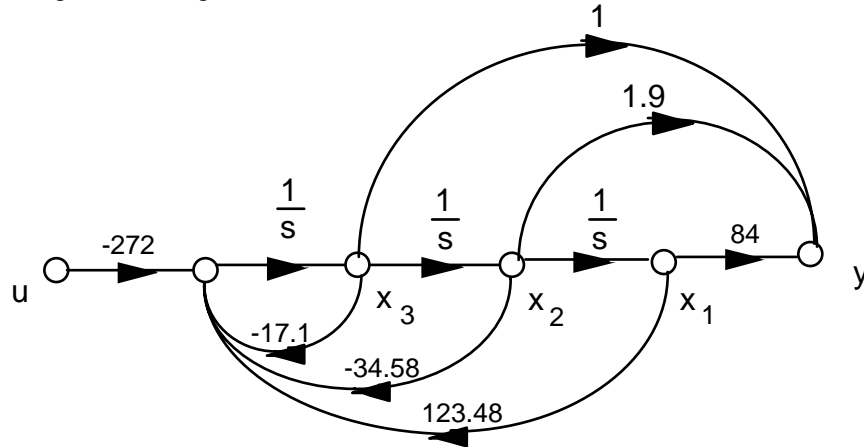

Writing the state and output equations:

$$\dot{x}_1 = x_2$$

$$\dot{x}_2 = x_3$$

$$\dot{x}_3 = 123.48x_1 - 34.58x_2 - 17.1x_3 - 272u$$

$$y = 84x_1 + 1.9x_2 + x_3$$

In vector-matrix form:

$$\dot{\mathbf{x}} = \begin{bmatrix} 0 & 1 & 0 \\ 0 & 0 & 1 \\ 123.48 & -34.58 & -17.1 \end{bmatrix} \mathbf{x} + \begin{bmatrix} 0 \\ 0 \\ -272 \end{bmatrix} u$$

$$y = [84 \quad 1.9 \quad 1] \mathbf{x}$$

b. Controller canonical form:  $G(s) = \frac{-272(s^2+1.9s+84)}{s^3+17.1s^2+34.58s-123.48}$

Drawing the signal-flow diagram:

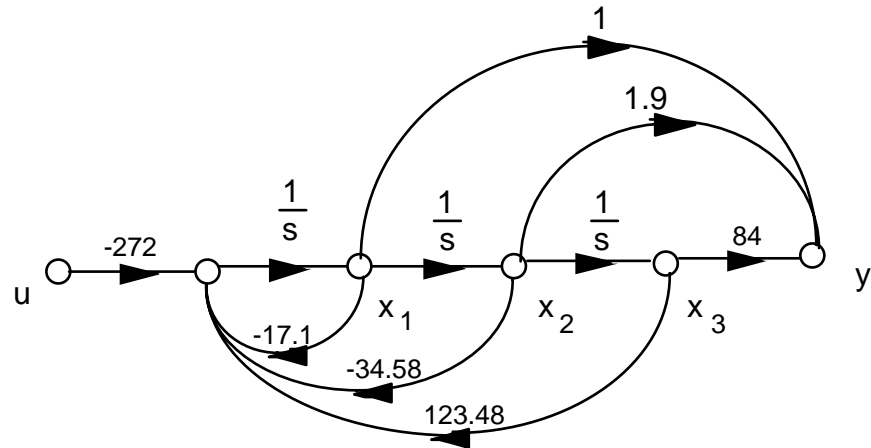

Writing the state and output equations:

$$\dot{x}_1 = -17.1x_1 - 34.58x_2 + 123.48x_3 - 272u$$

$$\dot{x}_2 = x_1$$

$$\dot{x}_3 = x_2$$

$$y = x_1 + 1.9x_2 + 84x_3$$

In vector-matrix form:

$$\dot{\mathbf{x}} = \begin{bmatrix} -17.1 & -34.58 & 123.48 \\ 1 & 0 & 0 \\ 0 & 1 & 0 \end{bmatrix} \mathbf{x} + \begin{bmatrix} -272 \\ 0 \\ 0 \end{bmatrix} u$$

$$y = [1 \quad 1.9 \quad 84] \mathbf{x}$$

c. Observer canonical form: Divide by highest power of  $s$  and obtain

$$G(s) = \frac{-\frac{272}{s} - \frac{516.8}{s^2} - \frac{22848}{s^3}}{1 + \frac{17.1}{s} + \frac{34.58}{s^2} - \frac{123.48}{s^3}}$$

Cross multiplying,

$$\left[ \frac{-272}{s} - \frac{516.8}{s^2} - \frac{22848}{s^3} \right] R(s) = \left[ 1 + \frac{17.1}{s} + \frac{34.58}{s^2} - \frac{123.48}{s^3} \right] C(s)$$

Rearranging,

$$C(s) = \frac{1}{s} [-272R(s) - 17.1C(s)] + \frac{1}{s^2} [-516.8R(s) - 34.58C(s)] + \frac{1}{s^3} [-22848R(s) + 123.48C(s)]$$

Drawing the signal-flow diagram, where  $r = u$  and  $y = c$ :

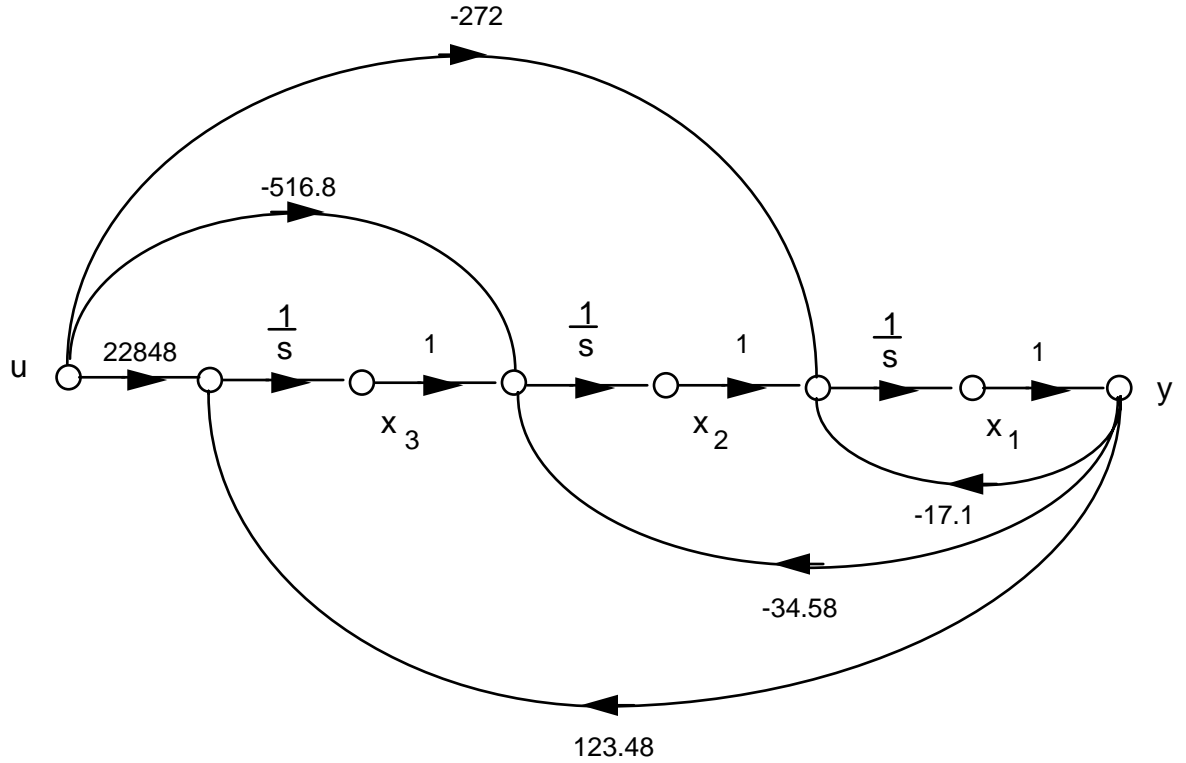

d. Draw signal-flow ignoring the polynomial in the numerator:

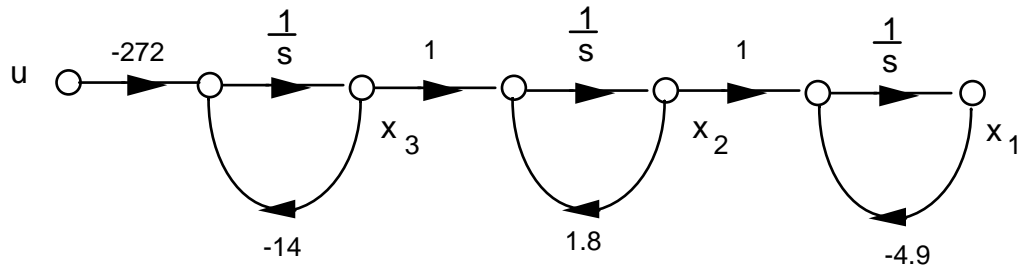

Write the state equations:

$$\dot{x}_1 = -4.9x_1 + x_2$$

$$\dot{x}_2 = 1.8x_2 + x_3$$

$$\dot{x}_3 = -14x_3 - 272u$$

The output equation is

$$y = \ddot{x}_1 + 1.9\dot{x}_1 + 84x_1 \tag{1}$$

But,

$$\dot{x}_1 = -4.9x_1 + x_2 \tag{2}$$

and

$$\ddot{x}_1 = -4.9\dot{x}_1 + \dot{x}_2 = -4.9(-4.9x_1 + x_2) + 1.8x_2 + x_3 \tag{3}$$

Substituting Eqs. (2) and (3) into (1) yields,

$$y = 98.7x_1 - 1.2x_2 + x_3$$

In vector-matrix form:

$$\dot{\mathbf{x}} = \begin{bmatrix} -4.9 & 1 & 0 \\ 0 & 1.8 & 1 \\ 0 & 0 & -14 \end{bmatrix} \mathbf{x} + \begin{bmatrix} 0 \\ 0 \\ -272 \end{bmatrix} u$$

$$y = [98.7 \quad -1.2 \quad 1] \mathbf{x}$$

e. Expand as partial fractions:

$$G(s) = -479.38 \frac{1}{s+14} - 232.94 \frac{1}{s-1.8} + 440.32 \frac{1}{s+4.9}$$

Draw signal-flow diagram:

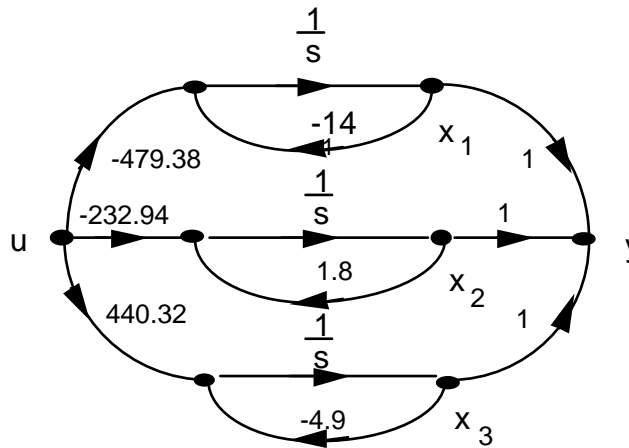

Write state and output equations:

$$\dot{x}_1 = -14x_1 + -479.38u$$

$$\dot{x}_2 = 1.8x_2 - 232.94u$$

$$\dot{x}_3 = -4.9x_3 + 440.32u$$

$$y = x_1 + x_2 + x_3$$

In vector-matrix form:

$$\dot{\mathbf{x}} = \begin{bmatrix} -14 & 0 & 0 \\ 0 & 1.8 & 0 \\ 0 & 0 & -4.9 \end{bmatrix} \mathbf{x} + \begin{bmatrix} -479.38 \\ -232.94 \\ 440.32 \end{bmatrix} u$$

$$y = [1 \quad 1 \quad 1] \mathbf{x}$$

54.

Push Pitch Gain to the right past the pickoff point.

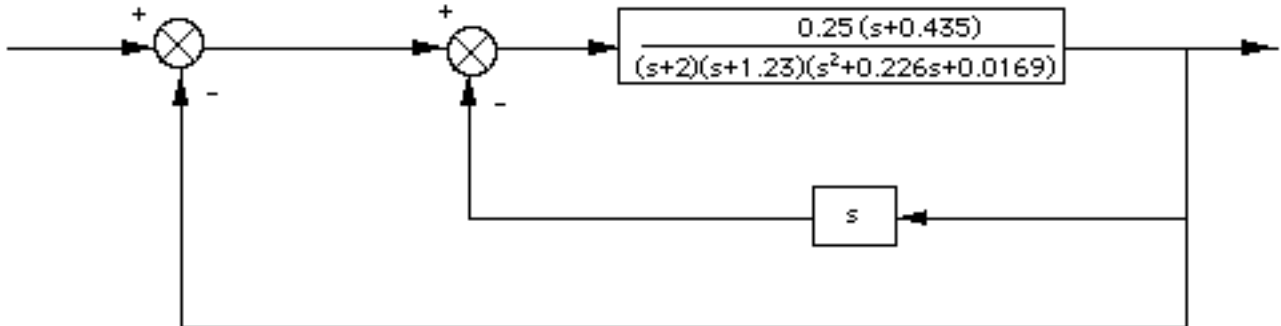

Collapse the summing junctions and add the feedback transfer functions.

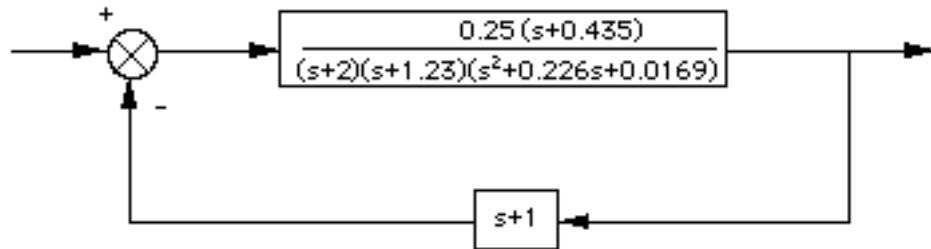

Apply the feedback formula and obtain,

$$T(s) = \frac{G(s)}{1 + G(s)H(s)} = \frac{0.25(s + 0.435)}{s^4 + 3.4586s^3 + 3.4569s^2 + 0.9693s + 0.15032}$$

55.

**Program:**

```

numg1=-0.125*[1 0.435]
deng1=conv([1 1.23],[1 0.226 0.0169])
'G1'
G1=tf(numg1,deng1)
'G2'
G2=tf(2,[1 2])
G3=-1
'H1'
H1=tf([-1 0],1)
'Inner Loop'
Ge=feedback(G1*G2,H1)
'Closed-Loop'
T=feedback(G3*Ge,1)

```

**Computer response:**

```

numg1 =
    -0.1250    -0.0544

```

5-72 Chapter 5: Reduction of Multiple Subsystems

```
deng1 =
      1.0000    1.4560    0.2949    0.0208
```

```
ans =
```

```
G1
```

```
Transfer function:
      -0.125 s - 0.05438
-----
s^3 + 1.456 s^2 + 0.2949 s + 0.02079
```

```
ans =
```

```
G2
```

```
Transfer function:
      2
-----
s + 2
```

```
G3 =
```

```
    -1
```

```
ans =
```

```
H1
```

```
Transfer function:
      -s
```

```
ans =
```

```
Inner Loop
```

```
Transfer function:
      -0.25 s - 0.1088
-----
s^4 + 3.456 s^3 + 3.457 s^2 + 0.7193 s + 0.04157
```

```
ans =
```

```
Closed-Loop
```

```
Transfer function:
      0.25 s + 0.1088
-----
s^4 + 3.456 s^3 + 3.457 s^2 + 0.9693 s + 0.1503
```



56.

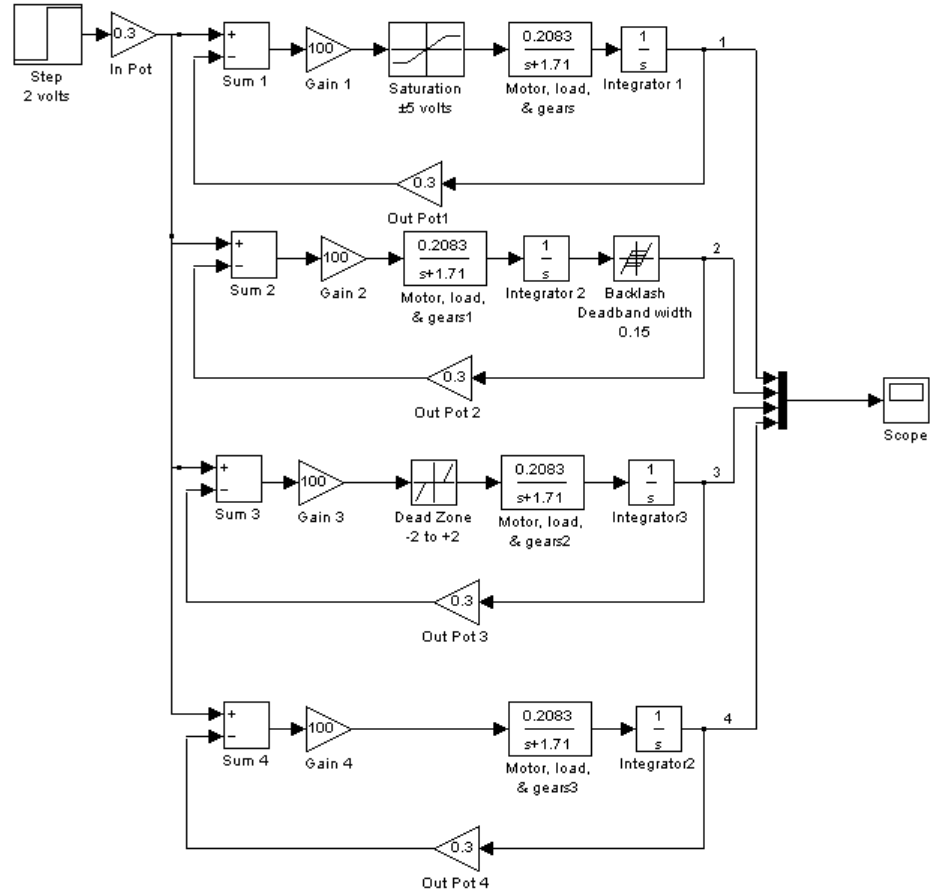

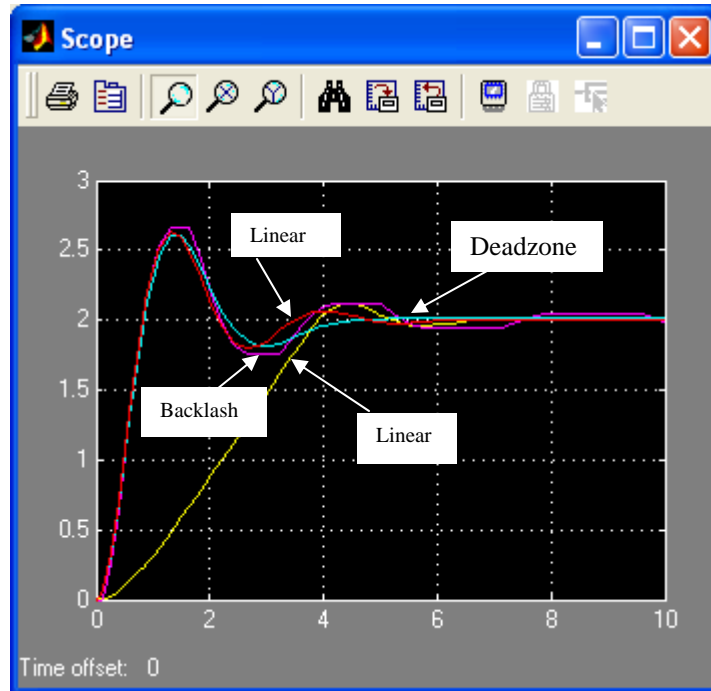

57.

a. Since  $V_L(s) = V_g(s) - V_R(s)$ , the summing junction has  $V_g(s)$  as the positive input and  $V_R(s)$  as the negative input, and  $V_L(s)$  as the error. Since  $I(s) = V_L(s) (1/(Ls))$ ,  $G(s) = 1/(Ls)$ . Also, since  $V_R(s) = I(s)R$ , the feedback is  $H(s) = R$ . Summarizing, the circuit can be modeled as a negative feedback system, where  $G(s) = 1/(Ls)$ ,  $H(s) = R$ , input =  $V_g(s)$ , output =  $I(s)$ , and error =  $V_L(s)$ , where the negative input to the summing junction is  $V_R(s)$ .

$$\text{b. } T(s) = \frac{I(s)}{V_g(s)} = \frac{G(s)}{1 + G(s)H(s)} = \frac{\frac{1}{Ls}}{1 + \frac{1}{Ls}R} = \frac{1}{Ls + R}. \text{ Hence, } I(s) = V_g(s) \frac{1}{Ls + R}.$$

$$\text{c. Using circuit analysis, } I(s) = \frac{V_g(s)}{Ls + R}.$$

58.

a.

$$T_1 = \frac{\alpha\beta}{s^2}, L_1 = -\frac{\alpha}{s}, L_2 = -\frac{\beta}{s}, \text{ No non-touching loops.}$$

$$\Delta = 1 + \frac{\alpha}{s} + \frac{\beta}{s}, \Delta_1 = 1$$

$$\frac{H_m(s)}{H_r(s)} = \frac{T_1 \Delta_1}{\Delta} = \frac{\frac{\alpha\beta}{s^2}}{1 + \frac{\alpha}{s} + \frac{\beta}{s}} = \frac{\alpha\beta}{s[s + (\alpha + \beta)]}$$

b.

$$T_1 = \frac{\alpha}{s}, L_1 = -\frac{\alpha}{s}, L_2 = -\frac{\beta}{s}, \text{No non-touching loops.}$$

$$\Delta = 1 + \frac{\alpha}{s} + \frac{\beta}{s}, \Delta_1 = 1$$

$$\frac{H_f(s)}{H_r(s)} = \frac{T_1 \Delta_1}{\Delta} = \frac{\frac{\alpha}{s}}{1 + \frac{\alpha}{s} + \frac{\beta}{s}} = \frac{\alpha}{s + (\alpha + \beta)}$$

c.

$$T_1 = \alpha, L_1 = -\frac{\alpha}{s}, L_2 = -\frac{\beta}{s}, \text{No non-touching loops.}$$

$$\Delta = 1 + \frac{\alpha}{s} + \frac{\beta}{s}, \Delta_1 = 1$$

$$\frac{Q_i(s)}{H_r(s)} = \frac{T_1 \Delta_1}{\Delta} = \frac{\alpha}{1 + \frac{\alpha}{s} + \frac{\beta}{s}} = \frac{\alpha s}{s + (\alpha + \beta)}$$

d.

$$T_1 = \frac{\alpha\beta}{s}, L_1 = -\frac{\alpha}{s}, L_2 = -\frac{\beta}{s}, \text{No non-touching loops.}$$

$$\Delta = 1 + \frac{\alpha}{s} + \frac{\beta}{s}, \Delta_1 = 1$$

$$\frac{Q_o(s)}{H_r(s)} = \frac{T_1 \Delta_1}{\Delta} = \frac{\frac{\alpha\beta}{s}}{1 + \frac{\alpha}{s} + \frac{\beta}{s}} = \frac{\alpha\beta}{s + (\alpha + \beta)}$$

e.

$$\text{Let } H_r(s) = \frac{K}{s}. \text{ From part d) } q_o(\infty) = \lim_{s \rightarrow 0} s Q_o(s) = \lim_{s \rightarrow 0} s \frac{\alpha\beta}{s + (\alpha + \beta)} H_r(s) = \frac{\alpha\beta}{\alpha + \beta} K =$$

constant

$$h_m(t) = \mathcal{L}^{-1}\{H_m(s)\} = \mathcal{L}^{-1}\left\{\frac{\alpha\beta}{s[s + (\alpha + \beta)]} H_r(s)\right\} = \mathcal{L}^{-1}\left\{\frac{\alpha\beta K}{s^2[s + (\alpha + \beta)]}\right\}$$

From (a)

$$= \mathcal{L}^{-1}\left\{\frac{K_1}{s^2} + \frac{K_2}{s} + \frac{K_3}{s + (\alpha + \beta)}\right\} = K_1 t + K_2 + K_3 e^{-(\alpha + \beta)t}$$

So  $\lim_{t \rightarrow \infty} h_m(t) = K_1 t + K_2$ . It is clear that  $h_m(t)$  increases at constant speed.

59.

a.

We start by finding  $\frac{U}{U_1}$  and  $\frac{U}{U_2}$  using Mason's Rule

$$\frac{U}{U_1}$$

$T_1 = G_c G_p$ ; Loops:  $L_1 = L_2 = A^2 G_l G_v$ , no non-touching loops.  $\Delta = 1 - 2A^2 G_l G_v$ ,  $\Delta_1 = 1$  Follows

$$\frac{U}{U_1} = \frac{G_c G_p}{1 - 2A^2 G_l G_v}$$

$$\frac{U}{U_2}$$

$T_1 = -G_c G_p$ ; Loops:  $L_1 = L_2 = A^2 G_l G_v$ , no non-touching loops.  $\Delta = 1 - 2A^2 G_l G_v$ ,  $\Delta_1 = 1$  Follows

$$\frac{U}{U_2} = \frac{-G_c G_p}{1 - 2A^2 G_l G_v}$$

By superposition  $U = \frac{G_c G_p}{1 - 2A^2 G_l G_v} (U_1 - U_2)$

b.

Now we find  $\frac{U}{F_{ext}}$

Two forward paths:  $T_1 = T_2 = A^2 G_l G_v$ , Loops:  $L_1 = L_2 = A^2 G_l G_v$ , no non-touching loops.

$\Delta = 1 - 2A^2 G_l G_v$ .  $\Delta_1 = \Delta_2 = 1$

$$\frac{U}{F_{ext}} = \frac{2A^2 G_l G_v}{1 - 2A^2 G_l G_v}$$

c. From (a) to get  $u = 0$  it is required that  $u_1 = u_2$ .

60.

a. The first equation follows from the schematic. The second equation is obtained by applying the voltage divider rule at the op-amp's inverting terminal, noting that since the op-amp considered is ideal, there is no current demand there.

b.  $T_1 = A$ ;  $L = -A \frac{R_i}{R_i + R_f}$ ;  $\Delta = 1 + A \frac{R_i}{R_i + R_f}$ ;  $\Delta_1 = 1$

$$\frac{v_o}{v_i} = \frac{T_1 \Delta_1}{\Delta} = \frac{A}{1 + A \frac{R_i}{R_i + R_f}}$$

$$\text{c. } \frac{v_o}{v_i} = \lim_{A \rightarrow \infty} \frac{A}{1 + A \frac{R_i}{R_i + R_f}} = \frac{1}{\frac{R_i}{R_i + R_f}} = 1 + \frac{R_f}{R_i}$$

61.

a. Adding currents at the op-amp's inverting terminal, under ideal condition we get

$$\frac{v_i - v_1}{R_i} = \frac{v_1 - v_o}{R_f} \text{ which after some algebraic manipulations gives } v_1 = \frac{R_f}{R_f + R_i} v_i + \frac{R_i}{R_f + R_i} v_o$$

Also from the circuits diagram  $v_o = -A v_1$

b. These equations can be represented by the following block diagram

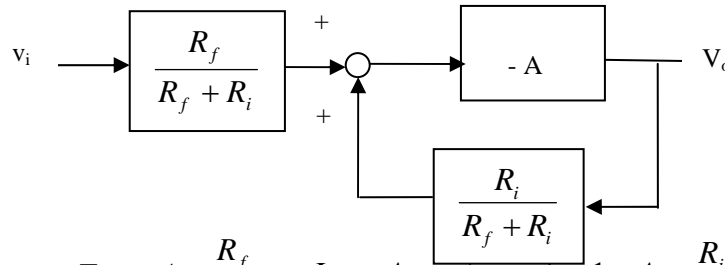

We have that  $T_1 = -A \frac{R_f}{R_f + R_i}$ ;  $L = -A \frac{R_i}{R_i + R_f}$ ;  $\Delta = 1 + A \frac{R_i}{R_i + R_f}$ ;  $\Delta_1 = 1$

$$\frac{v_o}{v_i} = \frac{T_1 \Delta_1}{\Delta} = \frac{-A \frac{R_f}{R_i + R_f}}{1 + A \frac{R_i}{R_i + R_f}}$$

$$\text{c. } \frac{v_o}{v_i} = \lim_{A \rightarrow \infty} \frac{-A \frac{R_f}{R_i + R_f}}{1 + A \frac{R_i}{R_i + R_f}} = \frac{-\frac{R_f}{R_i + R_f}}{\frac{R_i}{R_i + R_f}} = \frac{R_f}{R_i}$$

62.

a. The three equations follow by direct observation from the small signal circuit.

b. The block diagram is given by

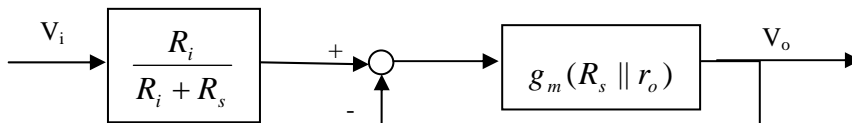

c. From the block diagram we get

$$\frac{v_o}{v_i} = \frac{g_m(R_s \parallel r_o)}{1 + g_m(R_s \parallel r_o)} \frac{R_i}{R_i + R_s}$$

63.

a. Using Mason's rule

$$T_1 = \frac{K_t}{s^2 + \omega_0^2} \frac{1}{M_{US}} = \frac{\omega_0^2}{s^2 + \omega_0^2}; \text{ Loops } L_1 = + \frac{\omega_0^2}{s^2 + \omega_0^2} \frac{\varepsilon}{s + \varepsilon} m_r \text{ and } L_2 = - \frac{\varepsilon m_r}{s + \varepsilon}, \text{ no non-}$$

touching loops.  $\Delta_1 = 1$

$$\frac{X_3}{R} = \frac{T_1 \Delta_1}{\Delta} = \frac{\frac{\omega_0^2}{s^2 + \omega_0^2}}{1 + m_r \frac{\varepsilon}{s + \varepsilon} - \frac{\omega_0^2}{s^2 + \omega_0^2} \frac{\varepsilon}{s + \varepsilon} m_r} = \frac{\frac{\omega_0^2}{s^2 + \omega_0^2}}{1 + \frac{\varepsilon m_r s^2}{(s + \varepsilon)(s^2 + \omega_0^2)}}$$

a. From part (a)

$$\frac{X_1}{R} = \frac{X_3}{R} \frac{\varepsilon}{s + \varepsilon} = \frac{\frac{\omega_0^2}{s^2 + \omega_0^2} \frac{\varepsilon}{s + \varepsilon}}{1 + \frac{\varepsilon m_r s^2}{(s + \varepsilon)(s^2 + \omega_0^2)}}$$

64.

a.

```
>> A=[-100.2 -20.7 -30.7 200.3; 40 -20.22 49.95 526.1;...
```

```
0 10.22 -59.95 -526.1; 0 0 0 0];
```

```
>> B=[208; -208; -108.8; -1];
```

```
>> C = [0 1570 1570 59400];
```

```
>> D = -6240;
```

```
>> [n,d]=ss2tf(A,B,C,D)
```

n =

1.0e+009 \*

Columns 1 through 3

-0.00000624000000 -0.00168228480000 -0.14206098728000

Columns 4 through 5

-3.91955218234127 -9.08349454230472

d =

1.0e+005 \*

Columns 1 through 3

0.00001000000000 0.00180370000000 0.09562734000000

Columns 4 through 5

1.32499100000000 0

```
>> roots(n)
```

```
ans =
```

```
1.0e+002 *
```

```
-1.34317654991673
```

```
-0.78476212102923
```

```
-0.54257777928519
```

```
-0.02545278053809
```

```
>> roots(d)
```

```
ans =
```

```
0
```

```
-92.38329312886714
```

```
-66.38046756013043
```

```
-21.60623931100260
```

Note that  $s \frac{Y}{U}(0) = 68555.14$ , follows that

$$\frac{Y}{U}(s) = -\frac{6348.17(s+2.5)(s+54.3)(s+78.5)(s+134.3)}{s(s+21.6)(s+66.4)(s+92.4)}$$

**b.**

```
>> [r,p,k]=residue(n,d)
```



r =

1.0e+005 \*

-0.73309459854184

-0.51344619392820

-3.63566779304453

-0.68555141448543

p =

-92.38329312886714

-66.38046756013043

-21.60623931100260

0

k =

-6240

$$\text{or } \frac{Y}{U}(s) = -6240 - \frac{73309.46}{s} - \frac{51344.6}{s + 21.6} - \frac{363566.8}{s + 66.4} - \frac{68555.14}{s + 92.4}$$

c.

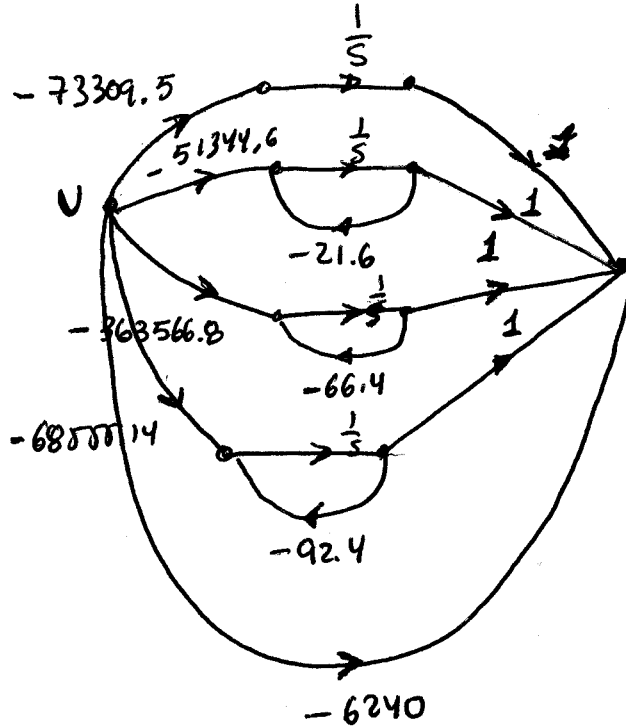

d. The corresponding state space representation is:

$$\begin{bmatrix} \dot{x}_1 \\ \dot{x}_2 \\ \dot{x}_3 \\ \dot{x}_4 \end{bmatrix} = \begin{bmatrix} 0 & 0 & 0 & 0 \\ 0 & -21.6 & 0 & 0 \\ 0 & 0 & -66.4 & 0 \\ 0 & 0 & 0 & -9.4 \end{bmatrix} \begin{bmatrix} x_1 \\ x_2 \\ x_3 \\ x_4 \end{bmatrix} + \begin{bmatrix} -73309.5 \\ -51344.6 \\ -363566.8 \\ -68555.14 \end{bmatrix} u(t)$$

$$y = \begin{bmatrix} 1 & 1 & 1 & 1 \end{bmatrix} \begin{bmatrix} x_1 \\ x_2 \\ x_3 \\ x_4 \end{bmatrix} - 6240u(t)$$

65.

a.

$$\gg A = [0 \ 1 \ 0; 0 \ -68.3 \ -7.2; 0 \ 3.2 \ -0.7]$$

A =

```
0 1.0000 0
0 -68.3000 -7.2000
0 3.2000 -0.7000
```

>> [V,D]=eig(A)

V =

```
1.0000 0.0147 -0.1016
0 -0.9988 0.1059
0 0.0475 -0.9892
```

D =

```
0 0 0
0 -67.9574 0
0 0 -1.0426
```

Matrix V is the sought similarity transformation.

**b.**

```
>> Ad = inv(V)*A*V
```

Ad =

```
0 -0.0000 -0.0000
0 -67.9574 0.0000
0 -0.0000 -1.0426
```

```
>> B = [0;425.4;0]
```

B =

```
0
425.4000
0
```

```
>> Bd = inv(V)*B
```

Bd =

```
4.2030
-428.1077
-20.5661
```

The diagonalized system is:

$$\begin{bmatrix} \dot{z}_1 \\ \dot{z}_2 \\ \dot{z}_3 \end{bmatrix} = \begin{bmatrix} 0 & 0 & 0 \\ 0 & -67.96 & 0 \\ 0 & 0 & -1.0426 \end{bmatrix} \begin{bmatrix} z_1 \\ z_2 \\ z_3 \end{bmatrix} + \begin{bmatrix} 4.2 \\ -428.11 \\ -20.57 \end{bmatrix} e_m$$

66.

a.

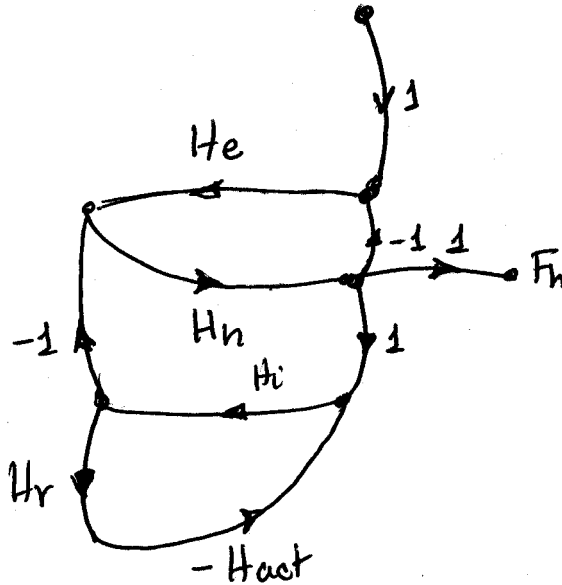

b. There is only one forward path  $T_1 = H_e H_h$

There are three loops:  $L_1 = -H_e H_h$ ;  $L_2 = -H_i H_h$  and  $L_3 = -H_i H_r H_{act}$

$L_1$  and  $L_3$  are non-touching loops so

$$\Delta = 1 - L_1 - L_2 - L_3 + L_1 L_3 = 1 + H_e H_h + H_i H_h + H_i H_r H_{act} + H_e H_h H_i H_r H_{act}$$

When  $T_1$  is eliminated only  $L_3$  is left so  $\Delta_1 = 1 - L_3 = 1 + H_r H_i H_{act}$

$$\text{Finally } \frac{F_h}{D}(s) = \frac{T_1 \Delta_1}{\Delta} = \frac{H_e H_h (1 + H_r H_i H_{act})}{1 + H_e H_h + H_i H_h + H_i H_r H_{act} + H_e H_h H_i H_r H_{act}}$$

67.

Enter Numerators and Denominator of System's Transfer Function--recall reverse order!

Numerator

0	2	7	1
---	---	---	---

Denominator

0	24	26	9	1
---	----	----	---	---

Transfer Function

$$\frac{s^2 + 7s + 2}{s^3 + 9s^2 + 26s + 24}$$

CONTROLLER and OBSERVER CANONICAL FORM SYSTEM PAGES 249-250

CONTROLLER CANONICAL FORM

$$\mathbf{dx}/dt = \begin{bmatrix} -9 & -26 & -24 \\ 1 & 0 & 0 \\ 0 & 1 & 0 \end{bmatrix} \mathbf{x}(t) + \begin{bmatrix} 1 \\ 0 \\ 0 \end{bmatrix} \mathbf{u}(t)$$

$$\mathbf{y}(t) = \begin{bmatrix} 1 & 7 & 2 \end{bmatrix} \mathbf{x}(t) + \begin{bmatrix} 0 \end{bmatrix} \mathbf{u}(t)$$

OBSERVER CANONICAL FORM

$$\mathbf{dx}/dt = \begin{bmatrix} -9 & 1 & 0 \\ -26 & 0 & 1 \\ -24 & 0 & 0 \end{bmatrix} \mathbf{x}(t) + \begin{bmatrix} 1 \\ 7 \\ 2 \end{bmatrix} \mathbf{u}(t)$$

$$\mathbf{y}(t) = \begin{bmatrix} 1 & 0 & 0 \end{bmatrix} \mathbf{x}(t) + \begin{bmatrix} 0 \end{bmatrix} \mathbf{u}(t)$$

Block Diagram:

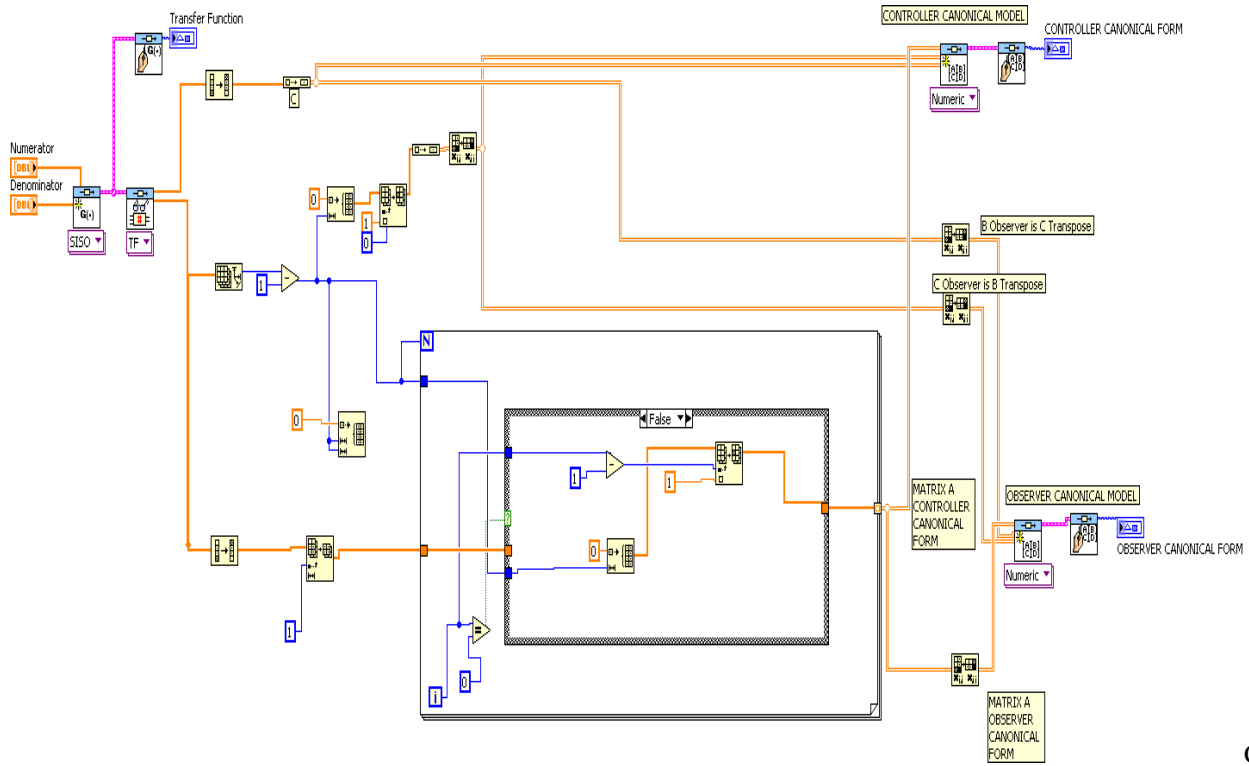

Case

Structure Details:

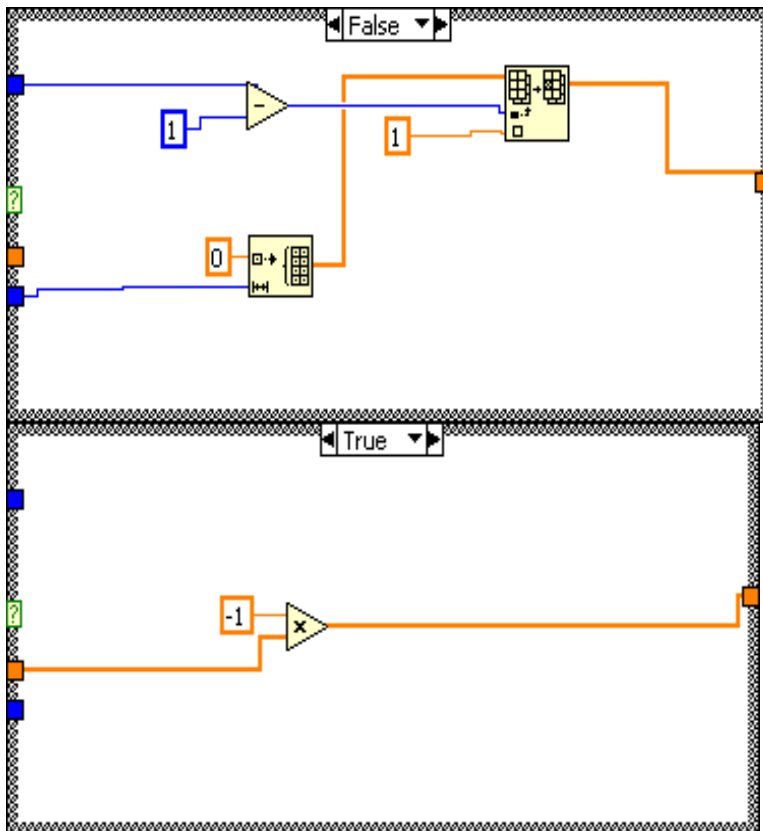

68.

a. There are two forwards paths:

$$M_1 = K_h K_{hs} C_s \frac{1}{s^2} \text{ and } M_2 = -K_h T_{es} K_{es} C_s \frac{1}{s}$$

The loops are:

$$L_1 = -K_h K_{hs} C_s \frac{1}{s^2} T_{hs}$$

$$L_2 = +K_h T_{es} K_{es} C_s T_{hs} \frac{1}{s}$$

$$L_3 = -C_j T_{ej} K_{ej}$$

$$L_4 = -K_h C_j T_{hj}$$

There are no non-touching loops. Therefore

$$\Delta = 1 + K_h K_{hs} C_s \frac{1}{s^2} T_{hs} - K_h T_{es} K_{es} C_s T_{hs} \frac{1}{s} + C_j T_{ej} K_{ej} + K_h C_j T_{hj}$$

 Also  $\Delta_1 = \Delta_2 = 1$ 

$$\frac{Y_s}{U_h} = \frac{M_1 \Delta_1 + M_2 \Delta_2}{\Delta} = \frac{K_h K_{hs} C_s \frac{1}{s^2} - K_h T_{es} K_{es} C_s \frac{1}{s}}{1 + K_h K_{hs} C_s \frac{1}{s^2} T_{hs} - K_h T_{es} K_{es} C_s T_{hs} \frac{1}{s} + C_j T_{ej} K_{ej} + K_h C_j T_{hj}}$$

b.

 There is only one forward path  $M_1 = K_h C_j$ 

 The loops and  $\Delta$  are the same as in part a. Also  $\Delta_1 = 1$ . It follows that

$$\frac{Y_j}{U_h} = \frac{M_1 \Delta_1}{\Delta} = \frac{K_h C_j}{1 + K_h K_{hs} C_s \frac{1}{s^2} T_{hs} - K_h T_{es} K_{es} C_s T_{hs} \frac{1}{s} + C_j T_{ej} K_{ej} + K_h C_j T_{hj}}$$

69.

 a. Assuming  $Z_h = 0$  there are two forward paths,  $M_1 = Z_m^{-1}$  and  $M_2 = C_6 Z_m^{-1}$ 

The loops are

$$L_1 = -G_s C_s$$

$$L_2 = -Z_m^{-1} C_m$$

$$L_3 = -Z_m^{-1} C_1 G_s C_4$$

$$L_4 = -Z_m^{-1} C_s G_s Z_e C_2$$



There are two non-touching loops  $L_1$  and  $L_2$ .

$$\begin{aligned}\Delta &= 1 + G_s C_s + Z_m^{-1} C_m + Z_m^{-1} C_1 G_s C_4 + Z_m^{-1} C_s G_s Z_e C_2 - G_s C_s Z_m^{-1} C_m \\ &= 1 + G_s C_s + Z_m^{-1} C_m + Z_m^{-1} C_s G_s Z_e C_2 = 1 + G_s C_s + Z_m^{-1} (C_m + C_s G_s Z_e C_2)\end{aligned}$$

We also have that by eliminating  $M_1$  or  $M_2$

$$\Delta_1 = \Delta_2 = 1 + G_s C_s$$

$$Y(s) = \frac{X_h}{F_h} = \frac{M_1 \Delta_1 + M_2 \Delta_2}{\Delta} = \frac{(Z_m^{-1} + Z_m^{-1} C_6)(1 + G_s C_s)}{1 + G_s C_s + Z_m^{-1} (C_m + C_2 Z_e G_s C_s)} = \frac{Z_m^{-1} C_2 (1 + G_s C_s)}{1 + G_s C_s + Z_m^{-1} (C_m + C_2 Z_e G_s C_s)}$$

b. The system can be described by means of the following diagram:

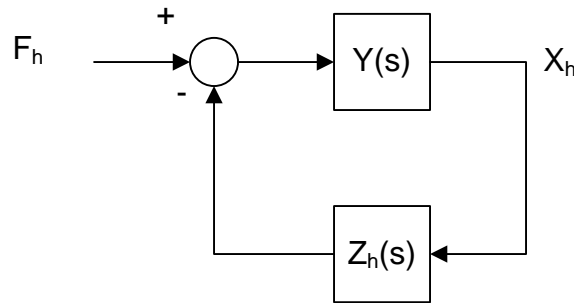

It follows that

$$\frac{X_h}{F_h} = \frac{Y(s)}{1 + Y(s)Z_h}$$

70.

a. There are three forward paths:

$$M_1 = K_{p2} \left( K_{p1} + \frac{K_{i1}}{s} \right) \frac{1}{L_f C_f \hat{C}_f s^3}$$

$$M_2 = \left( K_{p1} + \frac{K_{i1}}{s} \right) \frac{1}{L_f C_f s^2}$$

$$M_3 = (\hat{L}_f s + \hat{R}_f) \frac{1}{L_f C_f s^2}$$

The loops are:

$$L_1 = -K_{p2} \left( K_{p1} + \frac{K_{i1}}{s} \right) \frac{1}{L_f C_f s^2}$$

$$L_2 = - \left( K_{p1} + \frac{K_{i1}}{s} \right) \frac{1}{L_f s}$$

$$L_3 = -\frac{R_f}{L_f s}$$

There are no non-touching loops.

$$\Delta = 1 + K_{p2} \left( K_{p1} + \frac{K_{i1}}{s} \right) \frac{1}{L_f C_f s^2} + \left( K_{p1} + \frac{K_{i1}}{s} \right) \frac{1}{L_f s} + \frac{R_f}{L_f s}$$

$$\text{and } \Delta_1 = \Delta_2 = \Delta_3 = 1$$

$$\frac{V_{Load}}{I_{Cf}} = \frac{M_1 \Delta_1 + M_2 \Delta_2 + M_3 \Delta_3}{\Delta} = \frac{K_{p2} \left( K_{p1} + \frac{K_{i1}}{s} \right) \frac{1}{L_f C_f \hat{C}_f s^3} + \left( K_{p1} + \frac{K_{i1}}{s} \right) \frac{1}{L_f C_f s^2} + \left( \hat{L}_f s + \hat{R}_f \right) \frac{1}{L_f C_f s^2}}{1 + K_{p2} \left( K_{p1} + \frac{K_{i1}}{s} \right) \frac{1}{L_f C_f s^2} + \left( K_{p1} + \frac{K_{i1}}{s} \right) \frac{1}{L_f s} + \frac{R_f}{L_f s}}$$

b. There are three forward paths:

$$M_1 = K_{p2} \left( K_{p1} + \frac{K_{i1}}{s} \right) \frac{1}{L_f C_f \hat{C}_f s^3}$$

$$M_2 = \left( K_{p1} + \frac{K_{i1}}{s} \right) \frac{1}{L_f C_f s^2}$$

$$M_3 = \left( \hat{L}_f s + \hat{R}_f \right) \frac{1}{L_f C_f s^2}$$

The loops are:

$$L_1 = -K_{p2} \left( K_{p1} + \frac{K_{i1}}{s} \right) \frac{1}{L_f C_f s^2}$$

$$L_2 = -\left( K_{p1} + \frac{K_{i1}}{s} \right) \frac{1}{L_f s}$$

$$L_3 = -\frac{R_f}{L_f s}$$

There are no non-touching loops.

$$\Delta = 1 + K_{p2} \left( K_{p1} + \frac{K_{i1}}{s} \right) \frac{1}{L_f C_f s^2} + \left( K_{p1} + \frac{K_{i1}}{s} \right) \frac{1}{L_f s} + \frac{R_f}{L_f s}$$

$$\text{and } \Delta_1 = \Delta_2 = \Delta_3 = 1$$

$$\frac{V_{Load}}{I_{Cf}} = \frac{M_1 \Delta_1 + M_2 \Delta_2 + M_3 \Delta_3}{\Delta} = \frac{K_{p2} \left( K_{p1} + \frac{K_{i1}}{s} \right) \frac{1}{L_f C_f \hat{C}_f s^3} + \left( K_{p1} + \frac{K_{i1}}{s} \right) \frac{1}{L_f C_f s^2} + \left( \hat{L}_f s + \hat{R}_f \right) \frac{1}{L_f C_f s^2}}{1 + K_{p2} \left( K_{p1} + \frac{K_{i1}}{s} \right) \frac{1}{L_f C_f s^2} + \left( K_{p1} + \frac{K_{i1}}{s} \right) \frac{1}{L_f s} + \frac{R_f}{L_f s}}$$

71.

a. Substituting the values given above into the block diagram, when  $\Delta v_p = 0$ , we have:

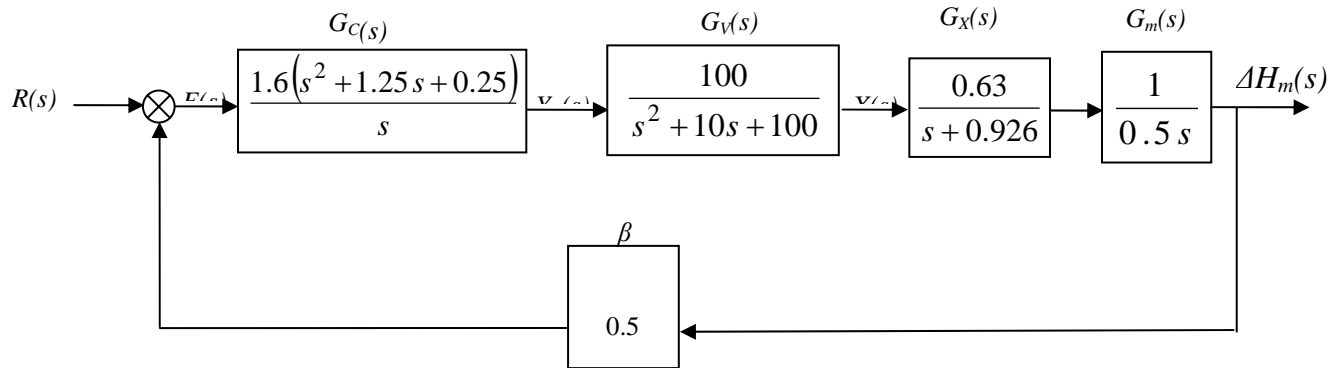

The Mould Level Block Diagram for  $\Delta v_p = 0$

Thus, the closed-loop transfer function is:

$$\begin{aligned}
 T(s) &= \frac{\Delta H_m(s)}{R(s)} = \frac{G_C(s) \cdot G_V(s) \cdot G_X(s) \cdot G_m(s)}{1 + \beta \cdot G_C(s) \cdot G_V(s) \cdot G_X(s) \cdot G_m(s)} = \\
 &= \frac{\frac{1.6(s^2 + 1.25s + 0.25)}{s} \left( \frac{100}{s^2 + 10s + 100} \right) \left( \frac{0.63}{s + 0.926} \right) \frac{1}{0.5s}}{1 + 0.5 \times \frac{1.6(s^2 + 1.25s + 0.25)}{s} \left( \frac{100}{s^2 + 10s + 100} \right) \left( \frac{0.63}{s + 0.926} \right) \frac{1}{0.5s}} = \\
 &= \frac{201.6(s^2 + 1.25s + 0.25)}{s^2(s^2 + 10s + 100)(s + 0.926) + 0.5 \times 201.6(s^2 + 1.25s + 0.25)} = \\
 &= \frac{201.6(s^2 + 1.25s + 0.25)}{s^5 + 10.93s^4 + 109.26s^3 + 193.4s^2 + 126s + 25.2}
 \end{aligned}$$

b. Simulink was used to simulate the system. The model of that system is shown in Figure P5.x-4\*. The parameters of the PID controller were set to:  $K_p = 2$ ,  $K_d = 1.6$ , and  $K_I = 0.4$ . The reference step,  $r(t) = 5 u(t)$ , and the casting speed step,  $v_p(t) = 0.97 u(t)$  were set to start at  $t = 0$ . An adder was used to add the initial value,

$H_m(0^-) = -75$  mm, at the output, to the change in mould level,  $\Delta H_m$ .

The time and mould level (in array format) were output to “workspace” sinks, each of which was given the respective variable name. After the simulation ended, Matlab plot commands were used to obtain and edit the graph of  $h_m(t)$  from 0 to  $t = 80$  seconds.

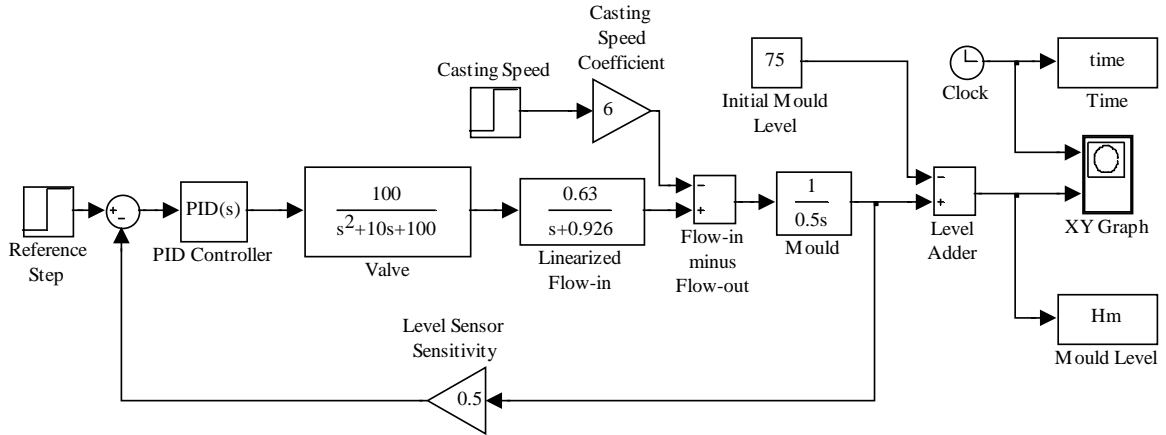

**Simulink Model of the Mould Level Control System**

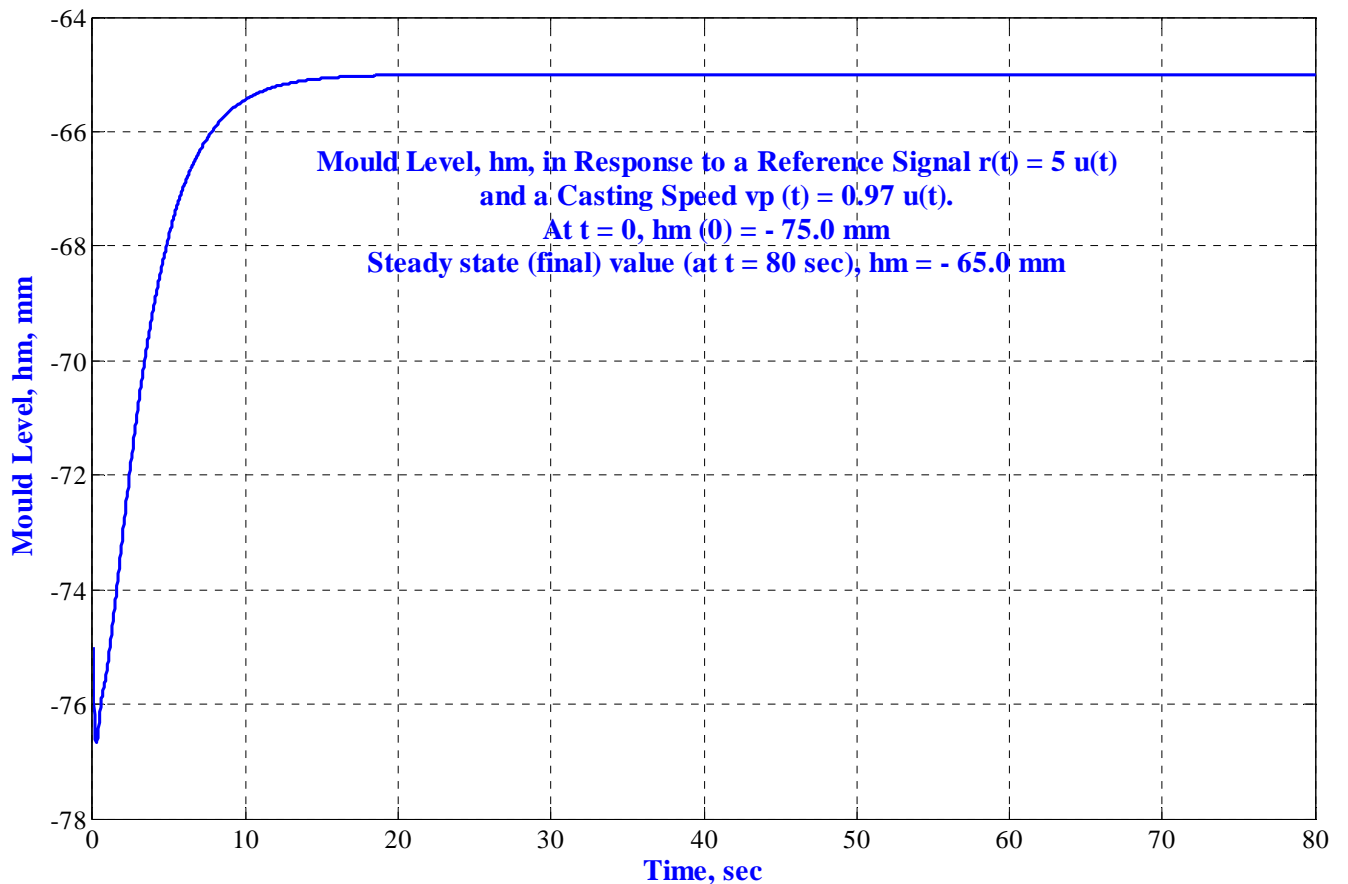

**Response of the Mould Level to Simultaneous Step Changes in Reference Input,  $r(t) = 5 u(t)$ , and Casting****Speed,  $v_p(t) = 0.97 u(t)$  at an Initial Level,  $H_m(0^-) = -75$** 

72.

a. Following the procedure described in Chapter 3 we define  $\frac{X_1}{\delta} = \frac{aV}{bh} \frac{1}{s^2 - \frac{g}{h}}$  and

$\varphi = (s + \frac{V}{A})X_1(s)$ . In time domain  $\ddot{x}_1 - \frac{g}{h}x_1 = \frac{aV}{bh}\delta$ .  $\varphi = \dot{x}_1 + \frac{V}{a}x_1$  and we also define

$\dot{x}_1 = x_2$ . These equations give

$$\begin{bmatrix} \dot{x}_1 \\ \dot{x}_2 \end{bmatrix} = \begin{bmatrix} 0 & 1 \\ \frac{g}{h} & 0 \end{bmatrix} \begin{bmatrix} x_1 \\ x_2 \end{bmatrix} + \begin{bmatrix} 0 \\ \frac{aV}{bh} \end{bmatrix} \delta$$

$$\varphi = \begin{bmatrix} \frac{V}{a} & 1 \end{bmatrix} \begin{bmatrix} x_1 \\ x_2 \end{bmatrix}$$

b. The eigenvalues can be obtained directly from the transfer function poles. Thus  $\lambda_{1,2} = \pm \sqrt{\frac{g}{h}}$

Consider  $\lambda_1 = \sqrt{\frac{g}{h}}$ , the first eigenvector is found from the solution of  $\mathbf{A}\mathbf{x}_1 = \lambda_1\mathbf{x}_1$  or

$$\begin{bmatrix} 0 & 1 \\ \frac{g}{h} & 0 \end{bmatrix} \begin{bmatrix} x_1 \\ x_2 \end{bmatrix} = \sqrt{\frac{g}{h}} \begin{bmatrix} x_1 \\ x_2 \end{bmatrix}. \text{ This results in } x_2 = \sqrt{\frac{g}{h}}x_1. \text{ Arbitrarily let } x_1 = 1 \text{ so the first}$$

eigenvector is  $\mathbf{v}_1 = \begin{bmatrix} 1 \\ \sqrt{\frac{g}{h}} \end{bmatrix}$ .

Similarly for  $\lambda_2 = -\sqrt{\frac{g}{h}}$ ;  $\mathbf{A}\mathbf{x}_2 = \lambda_2\mathbf{x}_2$  or  $\begin{bmatrix} 0 & 1 \\ \frac{g}{h} & 0 \end{bmatrix} \begin{bmatrix} x_1 \\ x_2 \end{bmatrix} = -\sqrt{\frac{g}{h}} \begin{bmatrix} x_1 \\ x_2 \end{bmatrix}$  resulting in

$$x_2 = -\sqrt{\frac{g}{h}}x_1. \text{ Letting arbitrarily } x_1 = 1 \text{ the second eigenvector is } \mathbf{v}_2 = \begin{bmatrix} 1 \\ -\sqrt{\frac{g}{h}} \end{bmatrix}.$$

c. The similarity transformation matrix is  $\mathbf{P} = [\mathbf{v}_1 \quad \mathbf{v}_2] = \begin{bmatrix} 1 & 1 \\ \sqrt{\frac{g}{h}} & -\sqrt{\frac{g}{h}} \end{bmatrix}$

$$\mathbf{P}^{-1} = \begin{bmatrix} -\sqrt{\frac{g}{h}} & -1 \\ -\sqrt{\frac{g}{h}} & 1 \\ -2\sqrt{\frac{g}{h}} & \end{bmatrix} = \begin{bmatrix} \frac{1}{2} & \frac{1}{2}\sqrt{\frac{h}{g}} \\ \frac{1}{2} & -\frac{1}{2}\sqrt{\frac{h}{g}} \end{bmatrix}$$

The matrices for the diagonalized are calculated as follows:

$$\mathbf{A}_d = \mathbf{P}^{-1}\mathbf{A}\mathbf{P} = \begin{bmatrix} \frac{1}{2} & \frac{1}{2}\sqrt{\frac{h}{g}} \\ \frac{1}{2} & -\frac{1}{2}\sqrt{\frac{h}{g}} \end{bmatrix} \begin{bmatrix} 0 & 1 \\ \frac{g}{h} & 0 \end{bmatrix} \begin{bmatrix} \sqrt{\frac{g}{h}} & 1 \\ \sqrt{\frac{g}{h}} & -\sqrt{\frac{g}{h}} \end{bmatrix} = \begin{bmatrix} \sqrt{\frac{g}{h}} & 0 \\ 0 & -\sqrt{\frac{g}{h}} \end{bmatrix}$$

$$\mathbf{B}_d = \mathbf{P}^{-1}\mathbf{B} = \begin{bmatrix} \frac{1}{2} & \frac{1}{2}\sqrt{\frac{h}{g}} \\ \frac{1}{2} & -\frac{1}{2}\sqrt{\frac{h}{g}} \end{bmatrix} \begin{bmatrix} 0 \\ aV \\ bh \end{bmatrix} = \begin{bmatrix} \frac{1}{2} \frac{aV}{b\sqrt{gh}} \\ -\frac{1}{2} \frac{aV}{b\sqrt{gh}} \end{bmatrix}$$

$$\mathbf{C}_d = \mathbf{C}\mathbf{P} = \begin{bmatrix} \frac{V}{a} & 1 \end{bmatrix} \begin{bmatrix} \sqrt{\frac{g}{h}} & -\sqrt{\frac{g}{h}} \end{bmatrix} = \begin{bmatrix} \frac{V}{a} + \sqrt{\frac{g}{h}} & \frac{V}{a} - \sqrt{\frac{g}{h}} \end{bmatrix}$$

The diagonalized representation is:

$$\begin{bmatrix} \dot{z}_1 \\ \dot{z}_2 \end{bmatrix} = \begin{bmatrix} \sqrt{\frac{g}{h}} & 0 \\ 0 & -\sqrt{\frac{g}{h}} \end{bmatrix} \begin{bmatrix} z_1 \\ z_2 \end{bmatrix} + \begin{bmatrix} \frac{1}{2} \frac{aV}{b\sqrt{gh}} \\ -\frac{1}{2} \frac{aV}{b\sqrt{gh}} \end{bmatrix} \delta$$

$$\varphi = \begin{bmatrix} \frac{V}{a} + \sqrt{\frac{g}{h}} & \frac{V}{a} - \sqrt{\frac{g}{h}} \end{bmatrix} \begin{bmatrix} z_1 \\ z_2 \end{bmatrix}$$

73.

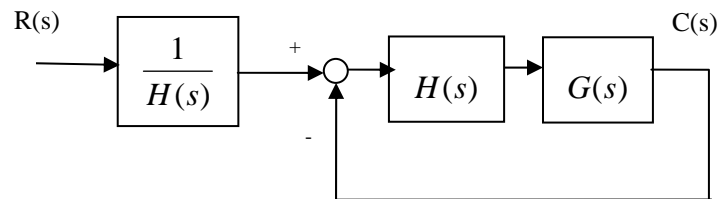

It can be easily verified that the closed loop transfer function for this system is identical to the original.

## SOLUTIONS TO DESIGN PROBLEMS

74.

$J_e = J_a + J_L \left(\frac{1}{20}\right)^2 = 2 + 2 = 4$ ;  $D_e = D_a + D_L \left(\frac{1}{20}\right)^2 = 2 + D_L \left(\frac{1}{20}\right)^2$ . Therefore, the forward-path transfer

function is,

$$G(s) = (1000) \left( \frac{\frac{1}{4}}{s(s + \frac{1}{4}(D_e + 2))} \right) \left( \frac{1}{20} \right). \text{ Thus, } T(s) = \frac{G}{1+G} = \frac{\frac{25}{2}}{s^2 + \frac{1}{4}(D_e + 2)s + \frac{25}{2}}.$$

$$\text{Hence, } \zeta = \frac{-\ln\left(\frac{\%OS}{100}\right)}{\sqrt{\pi^2 + \ln^2\left(\frac{\%OS}{100}\right)}} = 0.456; \omega_n = \sqrt{\frac{25}{2}}; 2\zeta\omega_n = \frac{D_e + 2}{4}. \text{ Therefore } D_e = 10.9; \text{ from}$$

which  $D_L = 3560$ .

75.

a.  $T(s) = \frac{25}{s^2 + s + 25}$ ; from which,  $2\zeta\omega_n = 1$  and  $\omega_n = 5$ . Hence,  $\zeta = 0.1$ . Therefore,

$$\%OS = e^{-\zeta\pi/\sqrt{1-\zeta^2}} \times 100 = 72.92\%; T_s = \frac{4}{\zeta\omega_n} = 8.$$

b.  $T(s) = \frac{25K_1}{s^2 + (1+25K_2)s + 25K_1}$ ; from which,  $2\zeta\omega_n = 1+25K_2$  and  $\omega_n = 5\sqrt{K_1}$ . Hence,

$$\zeta = \frac{-\ln\left(\frac{\%OS}{100}\right)}{\sqrt{\pi^2 + \ln^2\left(\frac{\%OS}{100}\right)}} = 0.504. \text{ Also, } T_s = \frac{4}{\zeta\omega_n} = 0.2, \text{ Thus, } \zeta\omega_n = 20; \text{ from which } K_2 = \frac{39}{25} \text{ and}$$

$\omega_n = 39.68$ . Hence,  $K_1 = 62.98$ .

76.

The equivalent forward path transfer function is  $G_e(s) = \frac{K}{s(1+(1+K_2))}$ . Thus,  $T(s) = \frac{G_e(s)}{1+G_e(s)} =$

$\frac{K}{s^2 + (1+K_2)s + K}$ . Prior to tachometer compensation ( $K_2 = 0$ ),  $T(s) = \frac{K}{s^2 + s + K}$ . Therefore  $K = \omega_n^2 =$

100. Thus, after tachometer compensation,  $T(s) = \frac{100}{s^2 + (1+K_2)s + 100}$ . Hence,  $\omega_n = 10$ ;  $2\zeta\omega_n = 1+K_2$ .

Therefore,  $K_2 = 2\zeta\omega_n - 1 = 2(0.69)(10) - 1 = 12.8$ .

77.

At the  $N_2$  shaft, with rotation,  $\theta_L(s)$

$$(J_{eq}s^2 + D_{eq}s)\theta_L(s) + F(s)r = T_{eq}(s)$$

$$F(s) = (Ms^2 + f_v s)X(s)$$

Thus,

$$(J_{eq}s^2 + D_{eq}s)\theta_L(s) + (Ms^2 + f_v s)X(s)r = T_{eq}(s)$$

But,  $X(s) = r\theta_L(s)$ . Hence,

$$[(J_{eq} + Mr^2)s^2 + (D_{eq} + f_v r^2)s]\theta_L(s) = T_{eq}(s)$$

where

$$J_{eq} = J_a(2)^2 + J = 5$$

$$D_{eq} = D_a(2)^2 + D = 4 + D$$

$$r = 2$$

Thus, the total load inertia and load damping is

$$J_L = J_{eq} + Mr^2 = 5 + 4M$$

$$D_L = D_{eq} + f_v r^2 = 4 + D + (1)(2)^2 = 8 + D$$

Reflecting  $J_L$  and  $D_L$  to the motor yields,

$$J_m = \frac{(5 + 4M)}{4}; D_m = \frac{(8 + D)}{4}$$

Thus, the motor transfer function is

$$\frac{\theta_m(s)}{E_a(s)} \frac{\frac{K_t}{R_a J_m}}{s(s + \frac{1}{J_m}(D_m + \frac{K_t K_a}{R_a}))} = \frac{\frac{1}{J_m}}{s(s + \frac{1}{J_m}(D_m + 1))}$$

The gears are  $(10/20)(1) = 1/2$ . Thus, the forward-path transfer function is

$$G_e(s) = (500) \left( \frac{\frac{1}{J_m}}{s(s + \frac{1}{J_m}(D_m + 1))} \right) \frac{1}{2}$$

Finding the closed-loop transfer function yields,



$$T(s) = \frac{G_e(s)}{1 + G_e(s)} = \frac{250/J_m}{s^2 + \frac{D_m+1}{J_m}s + \frac{250}{J_m}}$$

For  $T_s = 2$ ,  $\frac{D_m+1}{J_m} = 4$ . For 20% overshoot,  $\zeta = 0.456$ . Thus,

$$2\zeta\omega_n = 2(0.456)\omega_n = \frac{D_m+1}{J_m} = 4$$

Or,  $\omega_n = 4.386 = \sqrt{\frac{250}{J_m}}$ ; from which  $J_m = 13$  and hence,  $D_m = 51$ . But,

$$J_m = \frac{(5 + 4M)}{4}; D_m = \frac{(8 + D)}{4}. \text{ Thus, } M = 11.75 \text{ and } D = 196.$$

78.

a. The leftmost op-amp equation can be obtained by superposition. Let  $v_o = 0$ , then the circuit is an inverting amplifier thus  $v_1 = -\frac{10k}{10k}v_{in} = -v_{in}$ . Now let  $v_{in} = 0$ , the circuit is a non-inverting amplifier with an equal resistor voltage divider at its input, thus

$$v_1 = \frac{10k}{10k + 10k} \left(1 + \frac{10k}{10k}\right)v_o = v_o. \text{ Adding both input components } v_1 = v_o - v_{in}$$

b. The two equations representing the system are:

$$v_1 = v_o - v_{in} \text{ and}$$

$$\frac{v_o}{v_{in}} = -\frac{\frac{1}{0.1\mu s}}{R + \frac{1}{0.1\mu s}} = -\frac{\frac{1}{0.1\mu R}}{s + \frac{1}{0.1\mu R}}$$

The block diagram is:

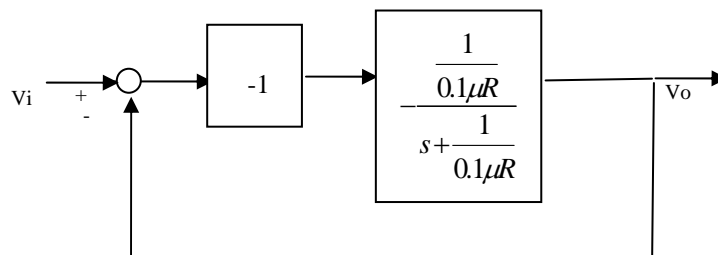

c. From the figure

$$\frac{v_o}{v_{in}} = \frac{\frac{1}{0.1\mu R}}{1 + \frac{1}{s + \frac{1}{0.1\mu R}}} = \frac{1}{s + \frac{2}{0.1\mu R}}$$

d. The system is first order so  $T_s = \frac{4}{2} = 0.2\mu R = 1m$  sec from which

$$R = \frac{1m}{0.2\mu} = 5k\Omega$$

e.  $\frac{v_o}{v_i} = \frac{2000}{s + 4000}$  For a unit step input the output will look as follows

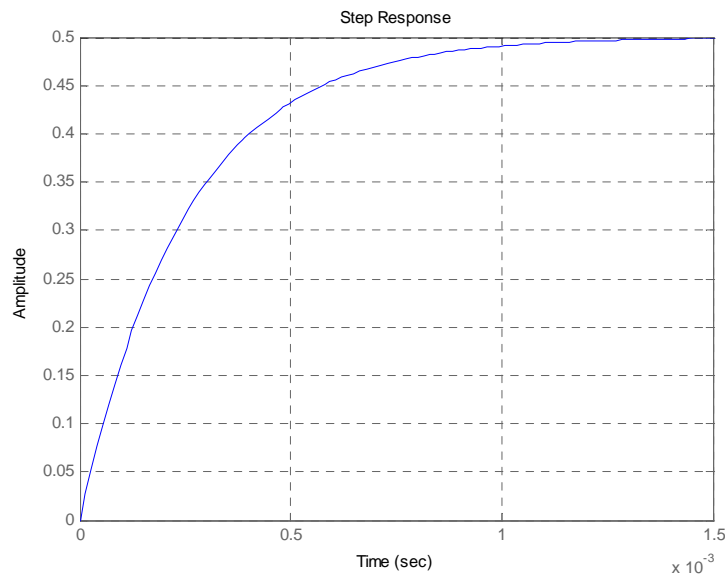

79.

a.

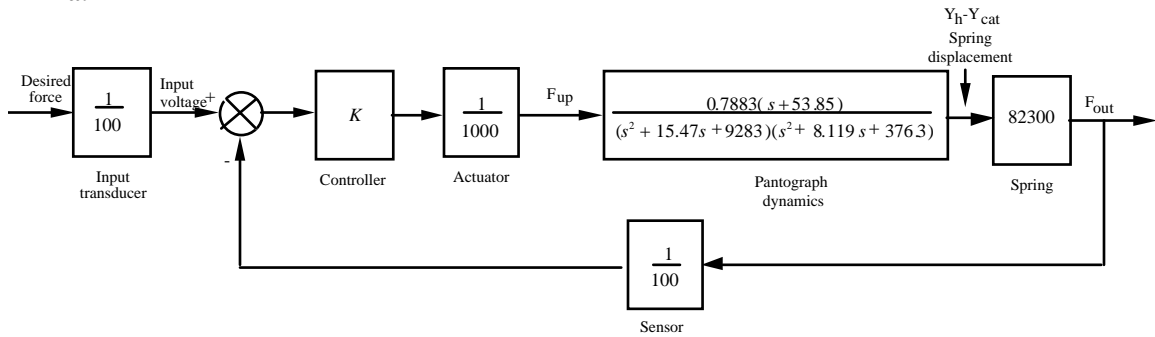

$$b. G(s) = \frac{Y_h(s) - Y_{cat}(s)}{F_{up}(s)} = \frac{0.7883(s + 53.85)}{(s^2 + 15.47s + 9283)(s^2 + 8.119s + 376.3)}$$

$$G_e(s) = (K/100) * (1/1000) * G(s) * 82.3e3 = \frac{648.7709 (s+53.85)}{(s^2 + 8.119s + 376.3) (s^2 + 15.47s + 9283)}$$

$$T(s) = G_e / (1 + G_e) = \frac{648.7709 (s+53.85)}{(s^2 + 8.189s + 380.2) (s^2 + 15.4s + 9279)}$$

$$= \frac{648.8 s + 3.494e04}{s^4 + 23.59 s^3 + 9785 s^2 + 8.184e04 s + 3.528e06}$$

c.

For  $G(s) = (y_h - y_{cat}) / F_{up}$

Phase-variable form

$A_p =$

0	1	0	0
0	0	1	0
0	0	0	1
-3.493e6	-81190	-9785	-23.59

$B_p =$

0  
0  
0  
1

$C_p =$

42.45      0.7883      0      0

Using this result to draw the signal-flow diagram,

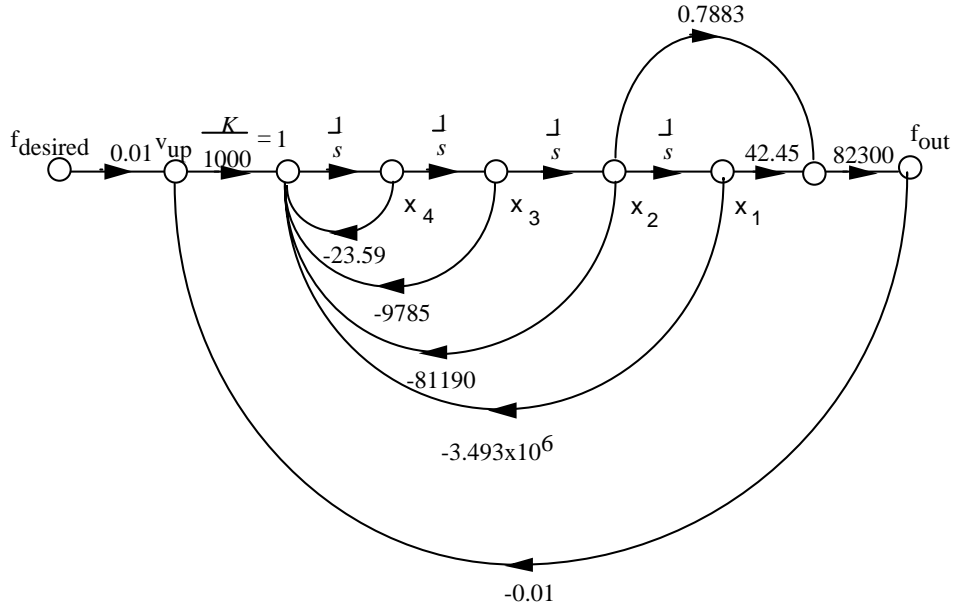

Writing the state and output equations

$$\dot{x}_1 = x_2$$

$$\dot{x}_2 = x_3$$

$$\dot{x}_3 = x_4$$

$$\dot{x}_4 = -23.59x_4 - 9785x_3 - 81190x_2 - 3493000x_1 + 0.01f_{desired} - 0.01f_{out}$$

But,

$$f_{out} = 42.45 * 82300x_1 + 0.7883 * 82300x_2$$

Substituting  $f_{out}$  into the state equations yields

$$\dot{x}_4 = -3527936.35x_1 - 81838.7709x_2 - 9785x_3 - 23.59x_4 + 0.01f_{desired}$$

Putting the state and output equations into vector-matrix form.

$$\dot{\mathbf{x}} = \begin{bmatrix} 0 & 1 & 0 & 0 \\ 0 & 0 & 1 & 0 \\ 0 & 0 & 0 & 1 \\ -3.528 \times 10^6 & -81840 & -9785 & -23.59 \end{bmatrix} \mathbf{x} + \begin{bmatrix} 0 \\ 0 \\ 0 \\ 0.01 \end{bmatrix} f_{desired}$$

$$y = f_{out} = [3494000 \quad 64880 \quad 0 \quad 0] \mathbf{x}$$

80.

a. The transfer function obtained in Problem 3.30 is

$$\frac{Y}{U_1} = \frac{-520s - 10.3844}{s^3 + 2.6817s^2 + 0.11s + 0.0126} \text{ by inspection we write the phase-variable form}$$

$$\begin{bmatrix} \dot{x}_1 \\ \dot{x}_2 \\ \dot{x}_3 \end{bmatrix} = \begin{bmatrix} 0 & 1 & 0 \\ 0 & 0 & 1 \\ -0.0126 & -0.11 & -2.6817 \end{bmatrix} \begin{bmatrix} x_1 \\ x_2 \\ x_3 \end{bmatrix} + \begin{bmatrix} 0 \\ 0 \\ 1 \end{bmatrix} u_1$$

$$y = \begin{bmatrix} -10.3844 & -520 & 0 \end{bmatrix} \begin{bmatrix} x_1 \\ x_2 \\ x_3 \end{bmatrix}$$

b. We renumber the phase-variable form state variables in reverse order

$$\begin{bmatrix} \dot{x}_3 \\ \dot{x}_2 \\ \dot{x}_1 \end{bmatrix} = \begin{bmatrix} 0 & 1 & 0 \\ 0 & 0 & 1 \\ -0.0126 & -0.11 & -2.6817 \end{bmatrix} \begin{bmatrix} x_3 \\ x_2 \\ x_1 \end{bmatrix} + \begin{bmatrix} 0 \\ 0 \\ 1 \end{bmatrix} u_1$$

$$y = \begin{bmatrix} -10.3844 & -520 & 0 \end{bmatrix} \begin{bmatrix} x_3 \\ x_2 \\ x_1 \end{bmatrix}$$

And we rearrange in ascending numerical order to obtain the controller canonical form:

$$\begin{bmatrix} \dot{x}_1 \\ \dot{x}_2 \\ \dot{x}_3 \end{bmatrix} = \begin{bmatrix} -2.6817 & -0.11 & -0.0126 \\ 1 & 0 & 0 \\ 0 & 0 & 1 \end{bmatrix} \begin{bmatrix} x_1 \\ x_2 \\ x_3 \end{bmatrix} + \begin{bmatrix} 1 \\ 0 \\ 0 \end{bmatrix} u_1$$

$$y = \begin{bmatrix} 0 & -520 & -10.3844 \end{bmatrix} \begin{bmatrix} x_1 \\ x_2 \\ x_3 \end{bmatrix}$$

c. To obtain the observer canonical form we rewrite the system's transfer function as:

$$\frac{Y}{U_1} = \frac{-\frac{520}{s^2} - \frac{10.3844}{s^3}}{1 + \frac{2.6817}{s} + \frac{0.11}{s^2} + \frac{0.0126}{s^3}}$$

We cross-multiply to obtain

$$\left[ -\frac{520}{s^2} - \frac{10.3844}{s^3} \right] U_1 = Y \left[ 1 + \frac{2.6817}{s} + \frac{0.11}{s^2} + \frac{0.0126}{s^3} \right]$$

Combining terms with like powers of integration:

$$\begin{aligned} Y &= \frac{1}{s} [-2.6817Y] + \frac{1}{s^2} [-520R - 0.11Y] + \frac{1}{s^3} [-10.3844R - 0.0126Y] \\ &= \frac{1}{s} \left[ -2.6817Y + \frac{1}{s} \left( [-520R - 0.11Y] + \frac{1}{s} [-10.3844R - 0.0126Y] \right) \right] \end{aligned}$$

We draw the signal flow graph:

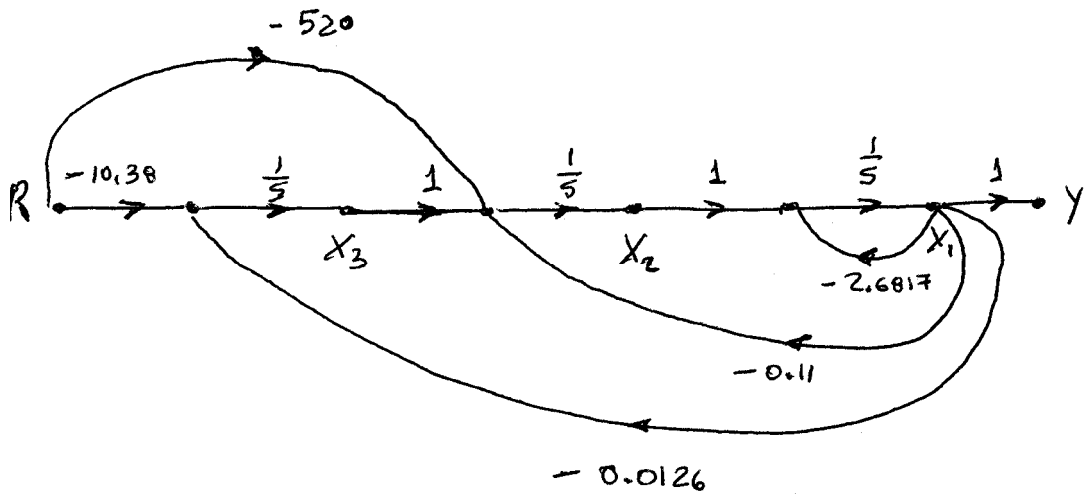

The following equations follow:

$$\dot{x}_1 = -2.6817x_1 + x_2$$

$$\dot{x}_2 = -0.11x_1 + x_3 - 520r$$

$$\dot{x}_3 = -0.0126x_1 - 10.38r$$

$$y = x_1$$

Which lead to observer canonical form:

$$\begin{bmatrix} \dot{x}_1 \\ \dot{x}_2 \\ \dot{x}_3 \end{bmatrix} = \begin{bmatrix} -2.6817 & 1 & 0 \\ -0.11 & 0 & 1 \\ -0.0126 & 0 & 0 \end{bmatrix} \begin{bmatrix} x_1 \\ x_2 \\ x_3 \end{bmatrix} + \begin{bmatrix} 1 \\ -520 \\ -10.38 \end{bmatrix} u_1; \quad y = \begin{bmatrix} 1 & 0 & 0 \end{bmatrix} \begin{bmatrix} x_1 \\ x_2 \\ x_3 \end{bmatrix}$$

**d.**

```
>> A=[-0.04167 0 -0.0058; 0.0217 -0.24 0.0058; 0 100 -2.4];
```

```
>> B=[5.2;-5.2;0];
```

```
>> C=[0 0 1];
```

```
>> [V,D]=eig(A);
```

```
>> Bd=inv(V)*B
```

Bd =

```
1.0e+002 *
```

```
-0.9936 + 0.0371i
```

```
-0.9936 - 0.0371i
```

```
1.9797
```

```
>> Cd = C*V
```

Cd =

```
0.9963 0.9963 1.0000
```

>> D

D =

$$\begin{bmatrix} -0.0192 + 0.0658i & 0 & 0 \\ 0 & -0.0192 - 0.0658i & 0 \\ 0 & 0 & -2.6433 \end{bmatrix}$$

So a diagonalized version of the system is

$$\begin{bmatrix} \dot{x}_1 \\ \dot{x}_2 \\ \dot{x}_3 \end{bmatrix} = \begin{bmatrix} -0.0192 + j0.0658 & 0 & 0 \\ 0 & -0.0192 - j0.0658 & 0 \\ 0 & 0 & -2.6433 \end{bmatrix} \begin{bmatrix} x_1 \\ x_2 \\ x_3 \end{bmatrix} + \begin{bmatrix} -99.36 + j3.71 \\ -99.36 - j3.71 \\ 197.97 \end{bmatrix} u_1$$

$$y = \begin{bmatrix} 0.9963 & 0.9963 & 1 \end{bmatrix} \begin{bmatrix} x_1 \\ x_2 \\ x_3 \end{bmatrix}$$

- 81.**
- a. Substituting all values and transfer functions into the respective blocks of the system (Figure 4), we get:



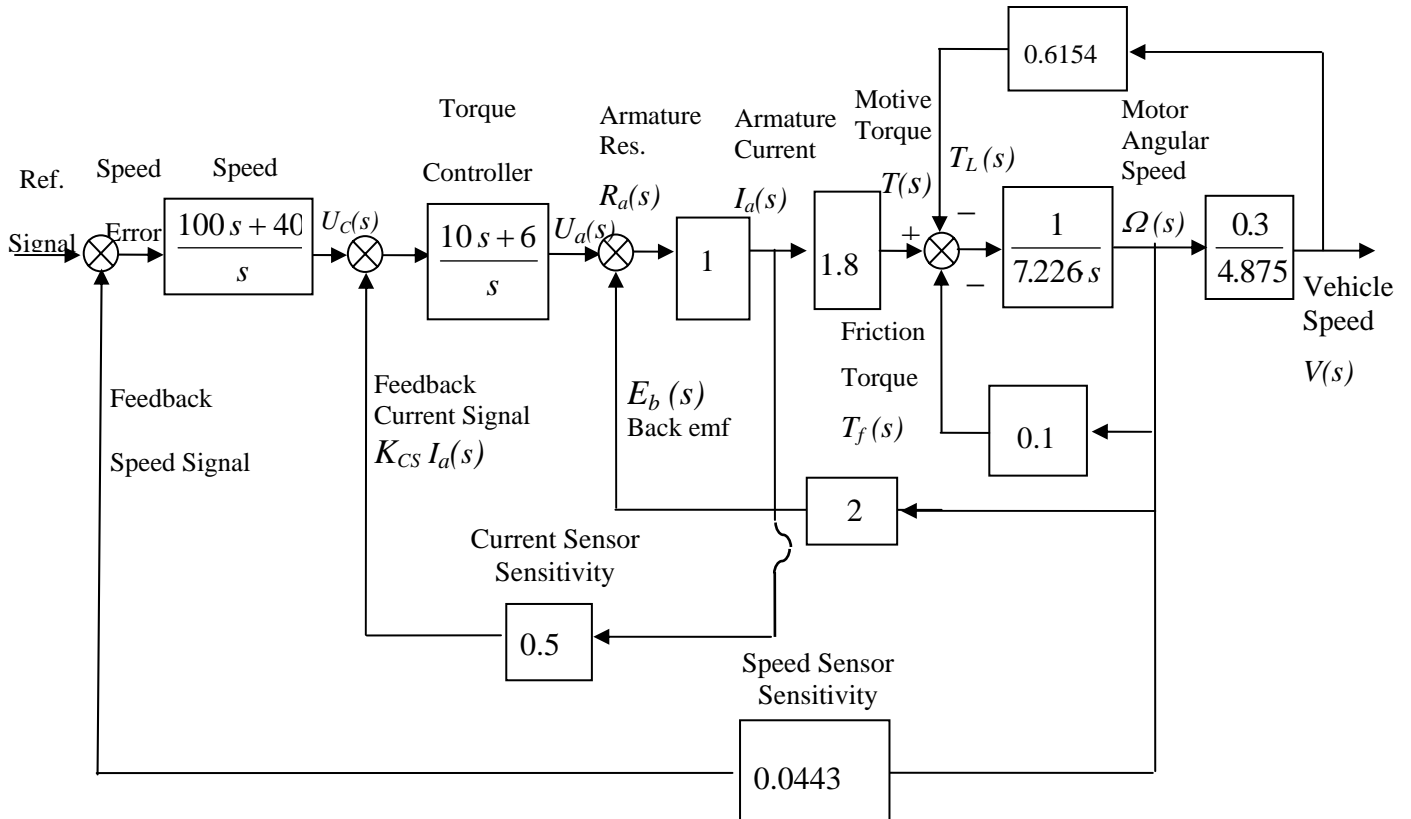

Moving the last pick-off point to the left past the  $\frac{r}{i_{tot}} = \frac{0.3}{4.875} = 0.06154$  block and changing the position of the

back-emf feedback pick-off point, so that it becomes an outer loop, we obtain the block-diagram shown below. In that diagram the  $\frac{1}{7.226s}$  block (representing the total inertia) has two parallel feedback blocks. Reducing these two

blocks into one, we have the following equivalent feedback transfer function:

$$G_{eq}(s) = \frac{\Omega(s)}{T(s)} = \frac{1}{1 + \frac{0.13787}{7.226s}} = \frac{0.1384}{s + 0.01908}$$

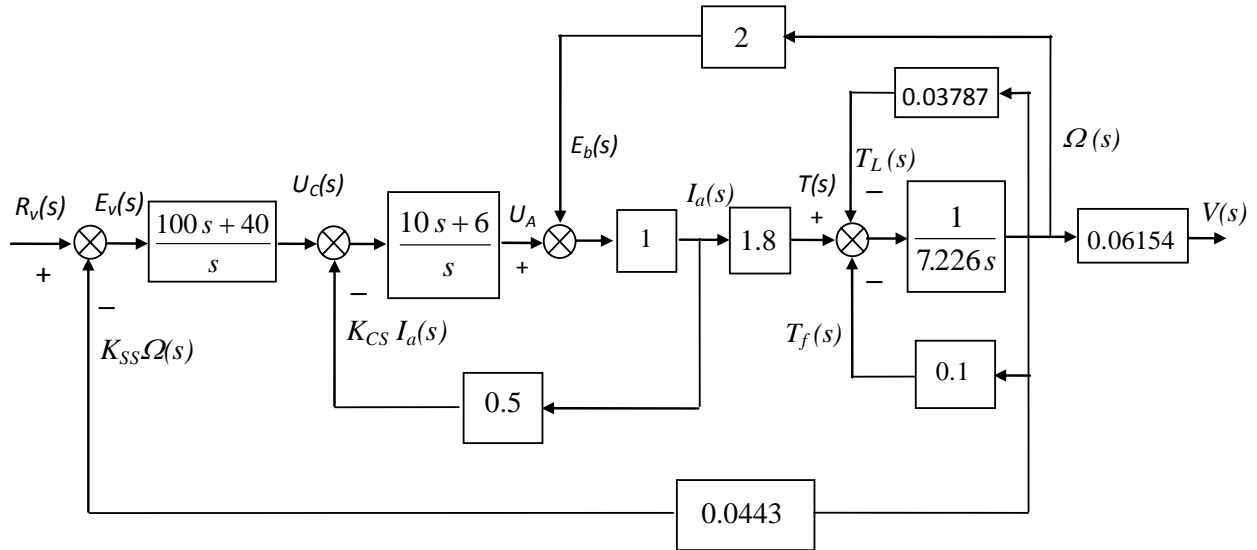

Replacing that feedback loop with its equivalent transfer function,  $G_{eq}(s)$ , we have:

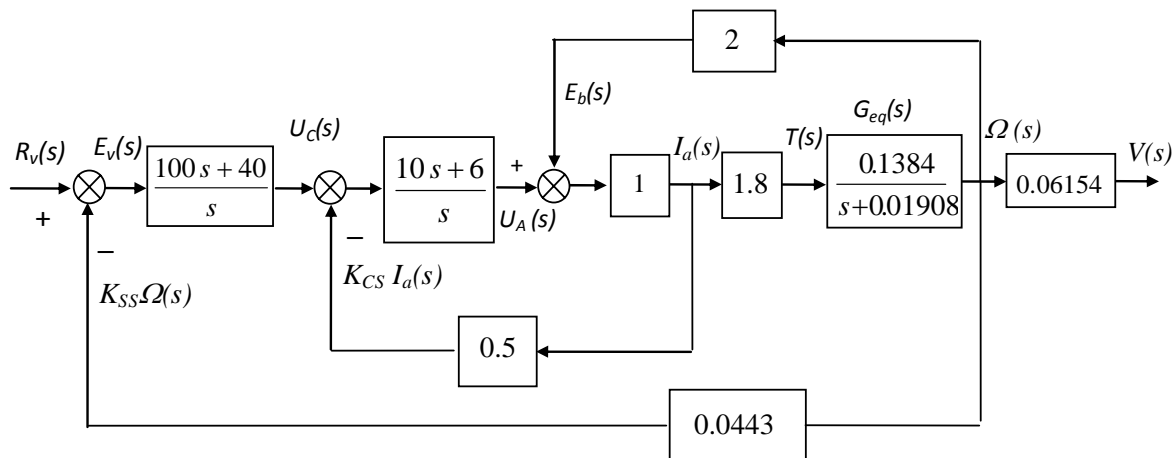

Moving the armature current pick-off point to the right past the  $\frac{T(s)}{I_a(s)}$  and  $G_{eq}(s)$  blocks, the above block-diagram

becomes as shown below.

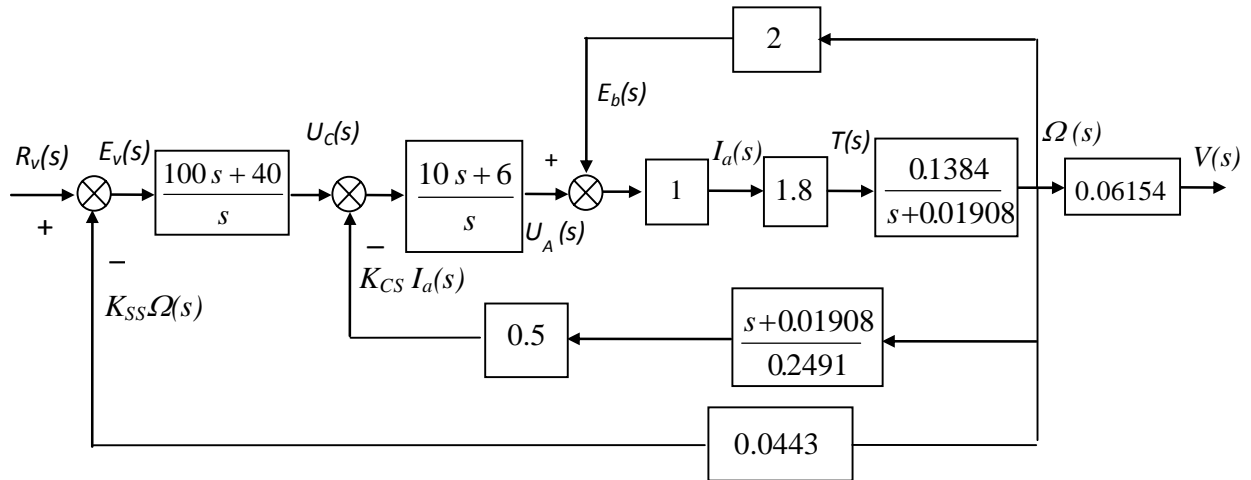

The latter, in turn, can be reduced to that shown next as the cascaded blocks in the feedback to the torque controller are replaced by the single block:  $\frac{K_{CS} I_a(s)}{\Omega(s)} = \frac{s + 0.01908}{0.4982}$  and the inner feedback loop is replaced by its

equivalent transfer function:

$$\frac{\Omega(s)}{U_A(s)} = \frac{\frac{0.2491}{s+0.01908}}{1 + \frac{0.2491}{s+0.01908} \times 2} = \frac{0.2491}{s+0.5173}$$

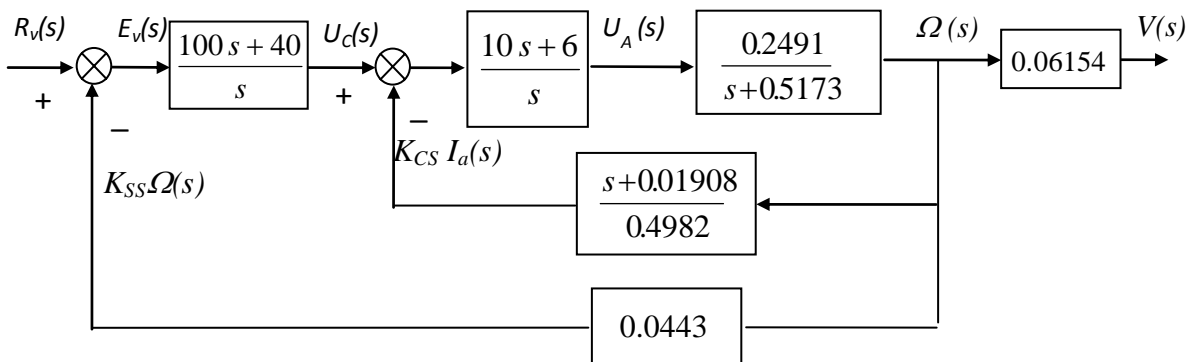

$$\text{Thus: } \frac{\Omega(s)}{U_c(s)} = \frac{\left(\frac{10s+6}{s}\right)\left(\frac{0.2491}{s+0.5173}\right)}{1 + \left(\frac{10s+6}{s}\right)\left(\frac{0.2491}{s+0.5173}\right)\left(\frac{s+0.01908}{0.4982}\right)} = \frac{0.2491(10s+6)}{s(s+0.5173) + 0.5(10s+6)(s+0.01908)}$$

$$\text{Finally } \frac{\Omega(s)}{R_v(s)} = \frac{\left(\frac{100s+40}{s}\right)\left(\frac{0.2491(10s+6)}{s(s+0.5173) + 0.5(10s+6)(s+0.01908)}\right)}{1 + 0.0443\left(\frac{100s+40}{s}\right)\left(\frac{0.2491(10s+6)}{s(s+0.5173) + 0.5(10s+6)(s+0.01908)}\right)} \text{ or}$$

$$\begin{aligned} \frac{\Omega(s)}{R_v(s)} &= \frac{2491(s+0.4)(s+0.6)}{s(6s^2+3.613s+0.0572)+11035(s^2+s+0.24)} \\ &= \frac{2491(s+0.4)(s+0.6)}{6s^3+14.644s^2+11.09s+2.65} \end{aligned}$$

$$\text{Hence: } \frac{V(s)}{R_v(s)} = 0.06154 \frac{\Omega(s)}{R_v(s)} = \frac{15.33(s+0.4)(s+0.6)}{6s^3+14.644s^2+11.09s+2.65}$$

**b.** Simulink was used to model the HEV cascade control system. That model is shown below. The reference signal,  $R_v(t)$ , was set as a step input with a zero initial value, a step time = 0 seconds, and a final value equal to 4 volts [corresponding to the desired final car speed,  $v(\infty) = 60$  km/h, e.g. a desired final value of the change in car speed,  $\Delta v(\infty) = 5.55$  m/s]. The variables of interest [time, change in car speed, acceleration, and motor armature current] were output (in array format) to four “workspace” sinks, each of which was assigned the respective variable name. After the simulation ended, Matlab plot commands were utilized to obtain and edit the required three graphs. These graphs are shown below.

The simulations show that in response to such a speed reference command, car acceleration would go initially to a maximum value of  $10.22 \text{ m/s}^2$  and the motor armature current would reach a maximum value of  $666.7 \text{ A}$ . That would require an electric motor drive rated around  $80 \text{ kW}$  or using both the electric motor and gas or diesel engine, when fast acceleration is required. Most practical HEV control systems, however, use current-limiting and acceleration-limiting devices or software programs.

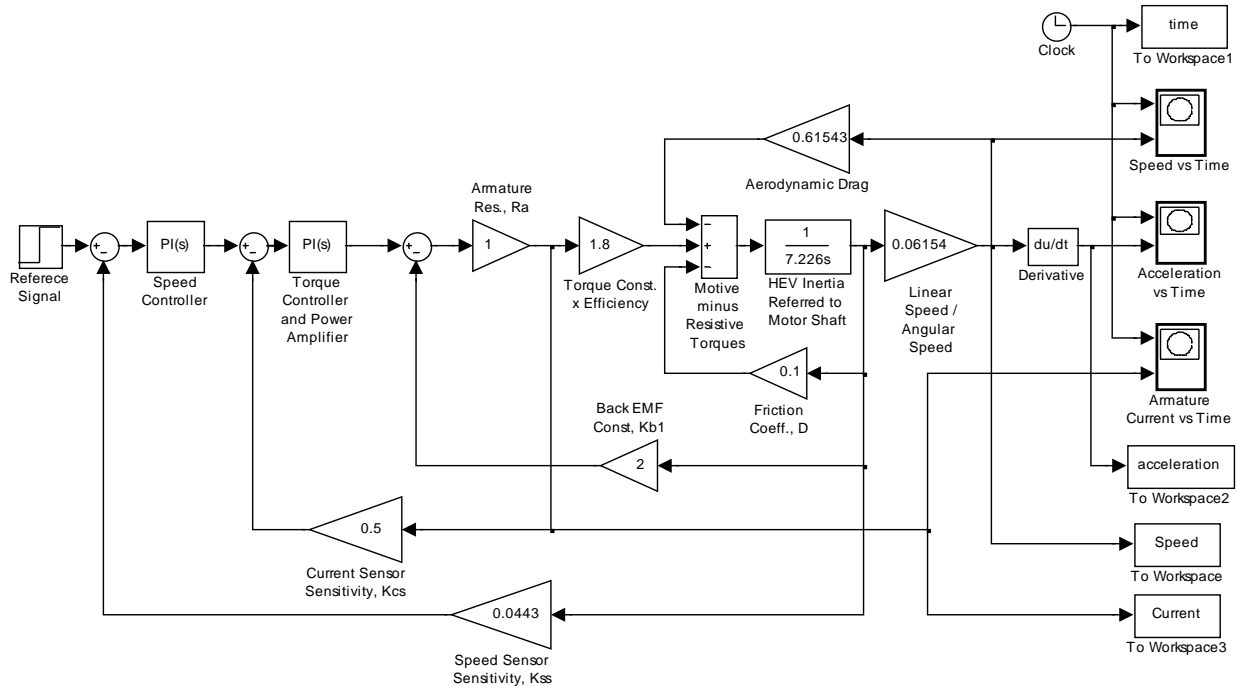

**Model of the HEV Cascade Control**

Change in Car Speed in Response to a Reference Step

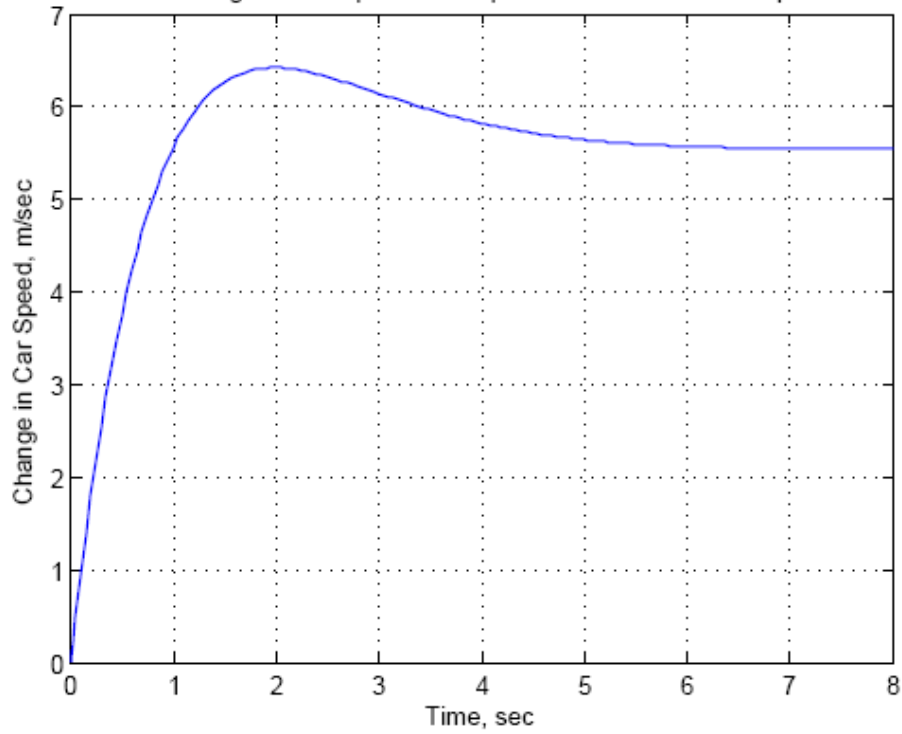

System

Change in car speed in response to a speed reference signal step of 4 volts

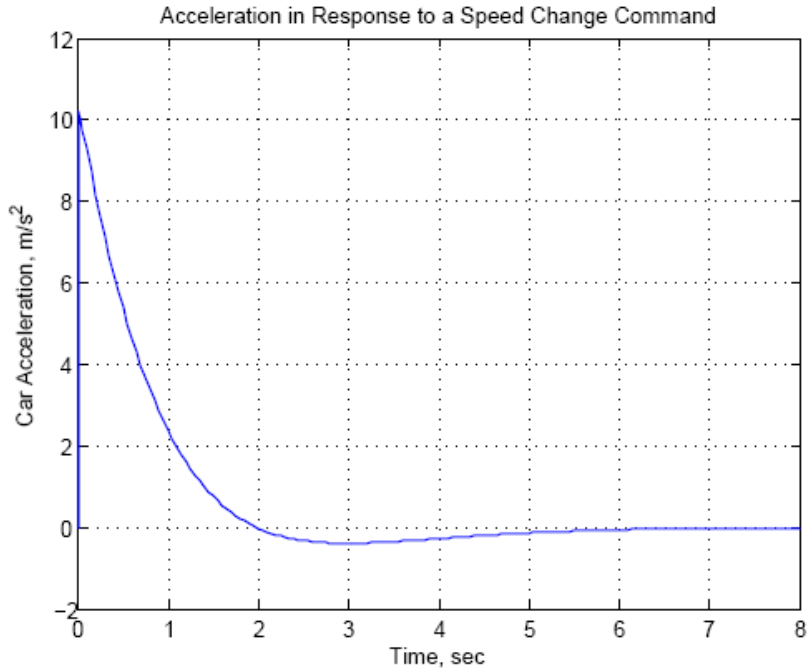

**Car acceleration response to a speed reference signal step of 4 volts**

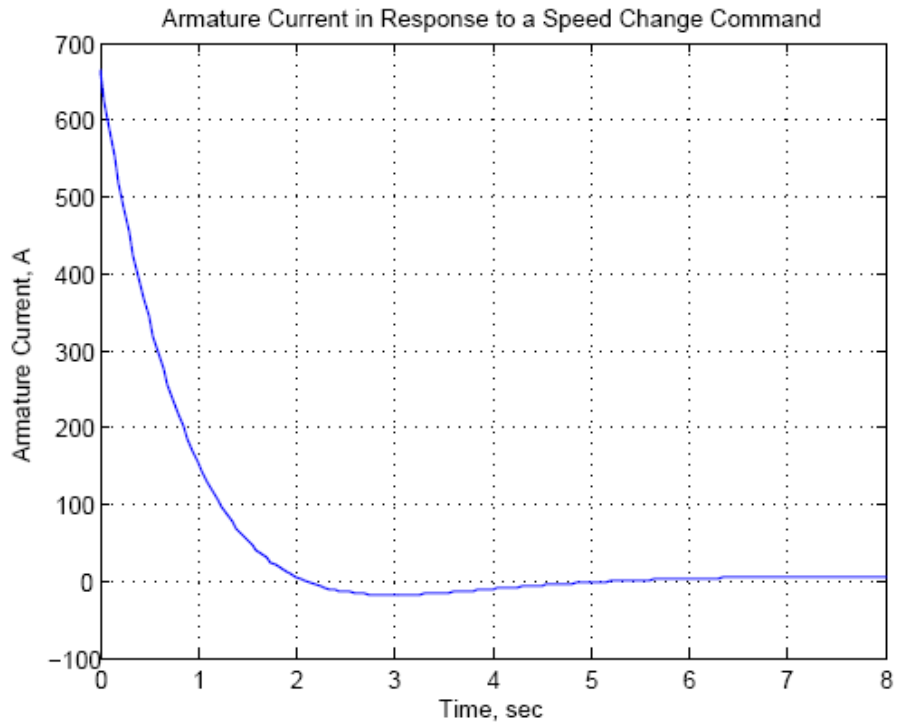

**Motor armature current response to a speed reference signal step of 4 volts**

# SIX

## Stability

### SOLUTIONS TO CASE STUDIES CHALLENGES

#### Antenna Control: Stability Design via Gain

From the antenna control challenge of Chapter 5,

$$T(s) = \frac{76.39K}{s^3 + 151.32s^2 + 198s + 76.39K}$$

Make a Routh table:

$s^3$	1	198
$s^2$	151.32	76.39K
$s^1$	$\frac{29961.36 - 76.39K}{151.32}$	0
$s^0$	76.39K	0

From the  $s^1$  row,  $K < 392.2$ . From the  $s^0$  row,  $0 < K$ . Therefore,  $0 < K < 392.2$ .

#### UFSS Vehicle: Stability Design via Gain

$$G_1 = \frac{-0.125(s + 0.437) \cdot 2}{s(s + 2)(s + 1.29)(s + 0.193)}$$

$$G_2 = \frac{G_1}{1 + G_1(-s)}$$

$$G_2 = \frac{-0.25s - 0.10925}{s^4 + 3.483s^3 + 3.465s^2 + 0.60719s}$$

$$G_3 = -K_1 G_2$$

$$G_3 = \frac{(0.25s + 0.10925)K_1}{s^4 + 3.483s^3 + 3.465s^2 + 0.60719s}$$

$$T(s) = \frac{G_3(s)}{1 + G_3(s)} = \frac{(0.25s + 0.10925)K_1}{s^4 + 3.483s^3 + 3.465s^2 + 0.25(K_1 + 2.4288)s + 0.10925K_1}$$

$s^4$	1	3.465	$0.10925K_1$
$s^3$	3.483	$0.25(K_1+2.4288)$	0
$s^2$	$\frac{-\frac{1}{4}(K_1 - 45.84)}{3.483}$	$0.10925K_1$	0
$s^1$	$0.25 \frac{(K_1 + 4.2141)(K_1 - 26.42)}{K_1 - 45.84}$	0	0
$s^0$	$0.10925K_1$	0	0

For stability :  $0 < K_1 < 26.42$

## ANSWERS TO REVIEW QUESTIONS

1. Natural response
2. It grows without bound
3. It would destroy itself or hit limit stops
4. Sinusoidal inputs of the same frequency as the natural response yield unbounded responses even though the sinusoidal input is bounded.
5. Poles must be in the left-half-plane or on the  $j\omega$  axis, but not multiple.
6. The number of poles of the closed-loop transfer function that are in the left-half-plane, the right-half-plane, and on the  $j\omega$  axis.
7. If there is an even polynomial of second order and the original polynomial is of fourth order, the original polynomial can be easily factored.
8. Just the way the arithmetic works out
9. The presence of an even polynomial that is a factor of the original polynomial
10. For the ease of finding coefficients below that row
11. It would affect the number of sign changes
12. Seven
13. No; it could have quadrantal poles.
14. None; the even polynomial has 2 right-half-plane poles and two left-half-plane poles.
15. Yes
16.  $\text{Det}(s\mathbf{I}-\mathbf{A}) = 0$



## SOLUTIONS TO PROBLEMS

1.

$s^5$	1	5	1
$s^4$	3	4	3
$s^3$	3.667	0	0
$s^2$	4	3	0
$s^1$	-2.75	0	0
$s^0$	3	0	0

2 rhp; 3 lhp

2.

The Routh array for  $P(s) = s^5 + 6s^3 + 5s^2 + 8s + 20$  is:

$s^5$	1	6	8
$s^4$	$\theta \varepsilon$	5	20
$s^3$	$-\frac{5}{\varepsilon}$	$-\frac{20}{\varepsilon}$	
$s^2$	5	20	
$s$	$\theta - 10$		
1	20		

The auxiliary polynomial for row 4 is  $Q(s) = 5s^2 + 20$ , with  $Q'(s) = 10$ , so there are two roots on the  $j\omega$ -axis. The first column shows two sign changes so there are two roots on the right half-plane.

The balance, one root must be in the left half-plane.

3.

$s^5$	1	4	3
$s^4$	-1	-4	-2
$s^3$	$\varepsilon$	1	0
$s^2$	$\frac{1-4\varepsilon}{\varepsilon}$	-2	0
$s^1$	$\frac{2\varepsilon^2+1-4\varepsilon}{1-4\varepsilon}$	0	0
$s^0$	-2	0	0

3 rhp, 2 lhp

4.

$s^5$	1	3	2
$s^4$	-1	-3	-2
$s^3$	-2	-3	ROZ
$s^2$	-3	-4	
$s^1$	-1/3		
$s^0$	-4		

Even (4): 4 j $\omega$ ; Rest(1): 1 rhp; Total (5): 1 rhp; 4 j $\omega$

5.

$s^4$	1	8	15	
$s^3$	4	20	0	
$s^2$	3	15	0	
$s^1$	6	0	0	ROZ
$s^0$	15	0	0	

Even (2):  $2j\omega$ ; Rest (2): 2 lhp; Total:  $2j\omega$ ; 2 lhp

6.

$s^6$	1	-6	1	-6
$s^5$	1	0	1	
$s^4$	-6	0	-6	
$s^3$	-24	0	0	ROZ
$s^2$	$\varepsilon$	-6		
$s^1$	$-144/\varepsilon$	0		
$s^0$	-6			

Even (4): 2 rhp; 2 lhp; Rest (2): 1 rhp; 1 lhp; Total: 3 rhp; 3 lhp

7.

**Program:**

```
den=[1 1 -6 0 1 1 -6]
A=roots(den)
```

**Computer response:**

den =

```
1    1    -6    0    1    1    -6
```

A =

```
-3.0000
 2.0000
-0.7071 + 0.7071i
```

```
-0.7071 - 0.7071i
0.7071 + 0.7071i
0.7071 - 0.7071i
```

## 8.

**Program:**

```
%-det([si() si();sj() sj()])/sj()
%Template for use in each cell.
syms e %Construct a symbolic object for
%epsilon.
%%%%%%%%%%%%%%%%%%%%%%%%%%%%%%%%%%%%%%%%%%%%%%%%%%%%%%%%%%%%%%%%%%%%%%%%
s5=[1 4 3 0 0] %Create s^5 row of Routh table.
%%%%%%%%%%%%%%%%%%%%%%%%%%%%%%%%%%%%%%%%%%%%%%%%%%%%%%%%%%%%%%%%%%%%%%%%
s4=[-1 -4 -2 0 0] %Create s^4 row of Routh table.
%%%%%%%%%%%%%%%%%%%%%%%%%%%%%%%%%%%%%%%%%%%%%%%%%%%%%%%%%%%%%%%%%%%%%%%%
if -det([s5(1) s5(2);s4(1) s4(2)])/s4(1)==0
    s3=[e...
        -det([s5(1) s5(3);s4(1) s4(3)])/s4(1) 0 0];
    %Create s^3 row of Routh table
    %if 1st element is 0.
else
    s3=[-det([s5(1) s5(2);s4(1) s4(2)])/s4(1) ...
        -det([s5(1) s5(3);s4(1) s4(3)])/s4(1) 0 0];
    %Create s^3 row of Routh table
    %if 1st element is not zero.
end
%%%%%%%%%%%%%%%%%%%%%%%%%%%%%%%%%%%%%%%%%%%%%%%%%%%%%%%%%%%%%%%%%%%%%%%%
if -det([s4(1) s4(2);s3(1) s3(2)])/s3(1)==0
    s2=[e ...
        -det([s4(1) s4(3);s3(1) s3(3)])/s3(1) 0 0];
    %Create s^2 row of Routh table
    %if 1st element is 0.
else
    s2=[-det([s4(1) s4(2);s3(1) s3(2)])/s3(1) ...
        -det([s4(1) s4(3);s3(1) s3(3)])/s3(1) 0 0];
    %Create s^2 row of Routh table
    %if 1st element is not zero.
end
%%%%%%%%%%%%%%%%%%%%%%%%%%%%%%%%%%%%%%%%%%%%%%%%%%%%%%%%%%%%%%%%%%%%%%%%
if -det([s3(1) s3(2);s2(1) s2(2)])/s2(1)==0
    s1=[e ...
        -det([s3(1) s3(3);s2(1) s2(3)])/s2(1) 0 0];
    %Create s^1 row of Routh table
    %if 1st element is 0.
else
    s1=[-det([s3(1) s3(2);s2(1) s2(2)])/s2(1) ...
        -det([s3(1) s3(3);s2(1) s2(3)])/s2(1) 0 0];
    %Create s^1 row of Routh table
    %if 1st element is not zero
end
%%%%%%%%%%%%%%%%%%%%%%%%%%%%%%%%%%%%%%%%%%%%%%%%%%%%%%%%%%%%%%%%%%%%%%%%
s0=[-det([s2(1) s2(2);s1(1) s1(2)])/s1(1) ...
    -det([s2(1) s2(3);s1(1) s1(3)])/s1(1) 0 0];
    %Create s^0 row of Routh table.
%%%%%%%%%%%%%%%%%%%%%%%%%%%%%%%%%%%%%%%%%%%%%%%%%%%%%%%%%%%%%%%%%%%%%%%%
's3' %Display label.
s3=simplify(s3); %Simplify terms in s^3 row.
pretty(s3) %Pretty print s^3 row.
's2' %Display label.
```

```

s2=simplify(s2);           %Simplify terms in s^2 row.
pretty(s2)                %Pretty print s^2 row.
's1'                      %Display label.
s1=simplify(s1);         %Simplify terms in s^1 row.
pretty(s1)                %Pretty print s^1 row.
's0'                      %Display label.
s0=simplify(s0);         %Simplify terms in s^0 row.
pretty(s0)                %Pretty print s^0 row.

```

**Computer response:**

s5 =

$$\begin{bmatrix} 1 & 4 & 3 & 0 & 0 \end{bmatrix}$$

s4 =

$$\begin{bmatrix} -1 & -4 & -2 & 0 & 0 \end{bmatrix}$$

ans =

s3

$$\begin{bmatrix} e & 1 & 0 & 0 \end{bmatrix}$$

ans =

s2

$$\begin{bmatrix} -1 + 4e & & & & \\ -\frac{-1 + 4e}{e} & -2 & 0 & 0 & \\ e & & & & \end{bmatrix}$$

ans =

s1

$$\begin{bmatrix} 2 & & & & \\ 2e^2 + 1 - 4e & & & & \\ -\frac{2e^2 + 1 - 4e}{-1 + 4e} & 0 & 0 & 0 & \\ -1 + 4e & & & & \end{bmatrix}$$

ans =

s0

$$\begin{bmatrix} -2 & 0 & 0 & 0 \end{bmatrix}$$

9.

$$T(s) = \frac{240}{s^4 + 10s^3 + 35s^2 + 50s + 264}$$

s4	1	35	264
s3	10	50	0
s2	30	264	0
s1	-38	0	0
s0	264	0	0

2 rhp, 2 lhp

10.

**Program:**

```

numg=240;
deng=poly([-1 -2 -3 -4]);
'G(s)'
G=tf(numg,deng)
'Poles of G(s)'
pole(G)
'T(s)'
T=feedback(G,1)
'Poles of T(s)'
pole(T)

```

**Computer response:**

ans =

G(s)

Transfer function:  
240

-----  
s^4 + 10 s^3 + 35 s^2 + 50 s + 24

ans =

Poles of G(s)

ans =

-4.0000  
-3.0000  
-2.0000  
-1.0000

ans =

T(s)

Transfer function:  
240

-----  
s^4 + 10 s^3 + 35 s^2 + 50 s + 264

ans =

Poles of T(s)

ans =

-5.3948 + 2.6702i  
-5.3948 - 2.6702i  
0.3948 + 2.6702i

$$0.3948 - 2.6702i$$

System is unstable, since two closed-loop poles are in the right half-plane.

11.

$$T(s) = \frac{1}{4s^4 + 4s^2 + 1}$$

s <sup>4</sup>	4	4	1	
s <sup>3</sup>	16	8	0	ROZ
s <sup>2</sup>	2	1	0	
s <sup>1</sup>	4	0	0	ROZ
s <sup>0</sup>	1	0	0	

Even (4): 4 jω

12.

The characteristic equation is:

$$1 + K \frac{(s+2)}{s(s-1)(s+3)} = 0 \text{ or}$$

$$s(s-1)(s+3) + K(s+2) = 0 \text{ or}$$

$$s^3 - 2s^2 + (K-3)s + 2K = 0$$

The Routh array is:

s <sup>3</sup>	1	K-3
s <sup>2</sup>	2	2K
s	-3	
1	2K	

The first column will always have a sign change regardless of the value of  $K$ . There is no value of  $K$  that will stabilize this system.

13.

$$T(s) = \frac{84}{s^8 + 5s^7 + 12s^6 + 25s^5 + 45s^4 + 50s^3 + 82s^2 + 60s + 84}$$

$s^8$	1	12	45	82	84
$s^7$	1	5	10	12	
$s^6$	1	5	10	12	
$s^5$	3	10	10		ROZ
$s^4$	5	20	36		
$s^3$	-5	-29			
$s^2$	-1	4			
$s^1$	-49				
$s^0$	4				

Even (6): 2 rhp, 2 lhp, 2 j $\omega$ ; Rest (2): 0 rhp, 2 lhp, 0 j $\omega$  ; Total: 2 rhp, 4 lhp, 2 j $\omega$

14.

$$T(s) = \frac{1}{2s^4 + 5s^3 + s^2 + 2s + 1}$$

$s^4$	2	1	1
$s^3$	5	2	0
$s^2$	1	5	
$s^1$	-23	0	
$s^0$	5		



Total: 2 lhp, 2 rhp  
System is unstable

15.

$$T(s) = \frac{8}{s^7 - 2s^6 - s^5 + 2s^4 + 4s^3 - 8s^2 - 4s + 8}$$

$s^7$	1	-1	4	-4	
$s^6$	-2	2	-8	8	
$s^5$	-12	8	-16	0	ROZ
$s^4$	0.6667	-5.333	8	0	
$s^3$	-88	128	0	0	
$s^2$	-4.364	8	0	0	
$s^1$	-33.33	0	0	0	
$s^0$	8	0	0	0	

Even (6): 3 rhp, 3 lhp; Rest (1): 1 rhp; Total: 4 rhp, 3 lhp

16.

**Program:**

```
numg=8;
deng=[1 -2 -1 2 4 -8 -4 0];
'G(s)'
G=tf(numg,deng)
'T(s)'
T=feedback(G,1)
'Poles of T(s)'
pole(T)
```

**Computer response:**

ans =

G(s)

Transfer function:

$$\frac{8}{s^7 - 2s^6 - s^5 + 2s^4 + 4s^3 - 8s^2 - 4s + 8}$$

ans =

T(s)

Transfer function:

$$\frac{8}{s^7 - 2s^6 - s^5 + 2s^4 + 4s^3 - 8s^2 - 4s + 8}$$

ans =

Poles of T(s)

ans =

- 1.0000 + 1.0000i
- 1.0000 - 1.0000i
- 1.0000
- 2.0000
- 1.0000 + 1.0000i
- 1.0000 - 1.0000i
- 1.0000

Thus, there are 4 rhp poles and 3 lhp poles.

17.

Even (6): 1 rhp, 1 lhp, 4 j $\omega$ ; Rest (1): 1 lhp; Total: 1 rhp, 2 lhp, 4 j $\omega$

18.

$$T(s) = \frac{18}{s^5 + s^4 - 7s^3 - 7s^2 - 18s - 18}$$

$s^5$	1	-7	-18	
$s^4$	1	-7	-18	
$s^3$	4	-14	0	ROZ
$s^2$	-3.5	-18	0	
$s^1$	-34.57	0	0	
$s^0$	-18	0	0	

Even (4): 1 rhp, 1 lhp, 2 j $\omega$ ; Rest (1): 1 lhp; Total: 1 rhp, 2 lhp, 2 j $\omega$

19.

$$G(s) = \frac{507}{s^4 + 3s^3 + 10s^2 + 30s + 169}; H(s) = \frac{1}{s}. \text{ Therefore,}$$

$$T(s) = \frac{G}{1+GH} = \frac{507s}{s^5 + 3s^4 + 10s^3 + 30s^2 + 169s + 507}$$

$s^5$	1	10	169	
$s^4$	3	30	507	
$s^3$	12	60	0	ROZ
$s^2$	15	507	0	
$s^1$	-345.6	0	0	
$s^0$	507	0	0	

Even (4): 2 rhp, 2 lhp, 0  $j\omega$ ; Rest (1): 0 rhp, 1 lhp, 0  $j\omega$ ; Total (5): 2 rhp, 3 lhp, 0  $j\omega$

20.

$$T(s) = \frac{K(s^2+1)}{(1+K)s^2 + 3s + (2+K)}$$

For a second-order system, if all coefficients are positive, the roots

will be in the lhp. Thus,  $K > -1$ .

21.

$$T(s) = \frac{K(s+6)}{s^3 + 5s^2 + (K+4)s + 6K}$$

$s^3$	1	$4 + K$
$s^2$	5	$6K$
$s^1$	$20 - K$	0
$s^0$	$6K$	0

Stable for  $0 < K < 20$

22.

The characteristic equation for all cases is  $1 + \frac{K(s-a)}{s(s-b)} = 0$  or  $s^2 + (K-b)s - Ka = 0$ . The

Routh array is

$s^2$	1	$-K$
$s$	$K-b$	
1	$-Ka$	

- a)  $a < 0, b < 0 \Rightarrow K > b, K > 0 \Rightarrow K > 0$   
 b)  $a < 0, b > 0 \Rightarrow K > b, K > 0 \Rightarrow K > b$   
 c)  $a > 0, b < 0 \Rightarrow K > b, K < 0 \Rightarrow b < K < 0$   
 d)  $a > 0, b > 0 \Rightarrow K > b, K < 0 \Rightarrow$  No solution

23.

$$T(s) = \frac{K(s+3)(s+5)}{(1+K)s^2 + (8K-6)s + (8+15K)}$$

			For 1 <sup>st</sup> column negative	For 1 <sup>st</sup> column positive
$s^2$	$1+K$	$8+15K$	$K < -1$	$K > -1$
$s^1$	$8K-6$	$0$	$K < 6/8$	$K > 6/8$
$s^0$	$8+15K$	$0$	$K < -8/15$	$K > -8/15$

Stable for  $K > 6/8$ 

24.

**Program:**

```

K=[-6:0.00005:0];
for i=1:length(K);
dent=[(1+K(i)) (8*K(i)-6) (8+15*K(i))];
R=roots(dent);
A=real(R);
B=max(A);
if B>0
R
K=K(i)
break
end
end
K=[6:-0.00005:0];
for i=1:length(K);
dent=[(1+K(i)) (8*K(i)-6) (8+15*K(i))];
R=roots(dent);
A=real(R);
B=max(A);
if B>0
R
K=K(i)
break
end
end

```

**Computer response:**

```
R =

1.0e+005 *

    2.7999
   -0.0000

K =

   -1.0000

R =

    0.0001 + 3.3166i
    0.0001 - 3.3166i

K =

    0.7500
```

25.

**Program:**

```
%-det([si() si();sj() sj()])/sj()
%Template for use in each cell.
syms K %Construct a symbolic object for
%gain, K.
s2=[(1+K) (8+15*K) 0]; %Create s^2 row of Routh table.
s1=[(8*K-6) 0 0]; %Create s^1 row of Routh table.
s0=[-det([s2(1) s2(2);s1(1) s1(2)])/s1(1) ...
    -det([s2(1) s2(3);s1(1) s1(3)])/s1(1) 0 0];
%Create s^0 row of Routh table.
's2' %Display label.
s2=simplify(s2); %Simplify terms in s^2 row.
pretty(s2) %Pretty print s^2 row.
's1' %Display label.
s1=simplify(s1); %Simplify terms in s^1 row.
pretty(s1) %Pretty print s^1 row.
's0' %Display label.
s0=simplify(s0); %Simplify terms in s^0 row.
pretty(s0) %Pretty print s^0 row.
```

**Computer response:**

```
ans =

s2

[1 + K      8 + 15 K      0]

ans =

s1

[8 K - 6      0      0]

ans =

s0
```

$$[8 + 15K \quad 0 \quad 0 \quad 0]$$

26.

$$T(s) = \frac{Ks^2 - 16K}{(K+1)s^2 + (3-16K)}. \text{ For positive coefficients in the denominator, } -1 < K < \frac{3}{16}.$$

Hence marginal stability only for this range of K.

27.

$$T(s) = \frac{K(s+1)}{s^5 + 2s^4 + Ks + K}. \text{ Always unstable since } s^3 \text{ and } s^2 \text{ terms are missing.}$$

28.

$$T(s) = \frac{Ks^3 + 7Ks^2 + 2Ks - 40K}{Ks^3 + (7K+1)s^2 + 2Ks + (12-40K)}$$

$s^3$	K	2K
$s^2$	$7K+1$	$12-40K$
$s^1$	$\frac{54K^2 - 10K}{7K+1}$	0
$s^0$	$12-40K$	

$$\text{For stability, } \frac{10}{54} < K < \frac{12}{40}$$

29.

$$T(s) = \frac{K(s+2)}{s^4 + 3s^3 - 3s^2 + (K+3)s + (2K-4)}$$

$s^4$	1	-3	$2K-4$
$s^3$	3	$K+3$	0
$s^2$	$\frac{-(K+12)}{3}$	$2K-4$	0
$s^1$	$\frac{K(K+33)}{K+12}$	0	0
$s^0$	$2K-4$	0	0

Conditions state that  $K < -12$ ,  $K > 2$ , and  $K > -33$ . These conditions cannot be met simultaneously.

System is not stable for any value of K.

30.

$$T(s) = \frac{K}{s^3 + 142s^2 + 6031s + (K + 79002)}$$

$s^3$	1	6031
$s^2$	142	$K+79002$
$s^1$	$(777400-K)/142$	0
$s^0$	$K+79002$	0

There will be a row of zeros at  $s^1$  row if  $K = 777400$ . The previous row,  $s^2$ , yields the auxiliary equation,  $142s^2 + (777400 + 79002) = 0$ . Thus,  $s = \pm j77.6595$ . Hence,  $K = 777400$  yields an oscillation of 77.6595 rad/s.

31.

$$T(s) = \frac{Ks^4 + 2Ks^2 - 4Ks + 8K}{(K+1)s^2 + 2(1-K)s + (2K+4)}$$

Since all coefficients must be positive for stability in a second-order polynomial,  $-1 < K < 1$ ;

$-\infty < K < 1$ ;  $-1 < 2K < \infty$ . Hence,  $-\frac{1}{2} < K < 1$ .

32.

$$T(s) = \frac{(s+2)(s+7)}{s^4 + 11s^3 + (K+31)s^2 + (8K+21)s + 12K}$$

Making a Routh table,

$s^4$	1	$K+31$	$12K$
$s^3$	11	$8K+21$	0
$s^2$	$\frac{3K+320}{11}$	$12K$	0
$s^1$	$\frac{24K^2 + 1171K + 6720}{3K+320}$	0	0
$s^0$	$12K$	0	0

$s^2$  row says  $-106.7 < K$ .  $s^1$  row says  $K < -42.15$  and  $-6.64 < K$ .  $s^0$  row says  $0 < K$ .

33.

$$T(s) = \frac{5K(s+4)}{5s^3 + 16s^2 + (12+5K)s + 20K}$$

Making a Routh table,

$s^3$	5	$12+5K$
$s^2$	16	$20K$
$s^1$	$192 - 20K$	0
$s^0$	$20K$	0

a. For stability,  $0 < K < 9.6$ .

b. Oscillation for  $K = 9.6$ .

c. From previous row with  $K = 9.6$ ,  $16s^2 + 192 = 0$ . Thus  $s = \pm j\sqrt{12}$ , or  $\omega = \sqrt{12}$  rad/s.

34.

$$\text{a. } G(s) = \frac{K(s-1)(s-2)}{(s+2)(s^2+2s+2)}. \text{ Therefore, } T(s) = \frac{(s-2)(s-1)K}{s^3 + (K+4)s^2 + (6-3K)s + 2(K+2)}.$$

Making a Routh table,

$s^3$	1	$6-3K$
$s^2$	$4+K$	$4+2K$
$s^1$	$\frac{-(3K^2+8K-20)}{K+4}$	0
$s^0$	$4+2K$	0

From  $s^1$  row:  $K = 1.57, -4.24$ ; From  $s^2$  row:  $-4 < K$ ; From  $s^0$  row:  $-2 < K$ . Therefore,  $-2 < K < 1.57$ .

b. If  $K = 1.57$ , the previous row is  $5.57s^2 + 7.14$ . Thus,  $s = \pm j1.13$ .

c. From part b,  $\omega = 1.13$  rad/s.

35.

Applying the feedback formula on the inner loop and multiplying by  $K$  yields



$$Ge = \frac{K}{s(s^2 + 10s + 22)}$$

Thus,

$$T = \frac{K}{s^3 + 10s^2 + 22s + K}$$

Making a Routh table:

$s^3$	1	22
$s^2$	10	K
$s^1$	$220 - K$	0
$s^0$	K	0

For oscillation, the  $s^1$  row must be a row of zeros. Thus,  $K = 220$  will make the system oscillate. The previous row now becomes,  $10s^2 + 220$ . Thus,  $s^2 + 22 = 0$ , or  $s = \pm j\sqrt{22} \sqrt{22}$ . Hence, the frequency of oscillation is  $\sqrt{22}$  rad/s.

36.

$$T(s) = \frac{Ks^2 + 2Ks}{s^3 + (K-1)s^2 + (2K-4)s + 24}$$

$s^3$	1	$2K-4$
$s^2$	$K-1$	24
$s^1$	$\frac{2K^2 - 6K - 20}{K-1}$	0
$s^0$	24	0

For stability,  $K > 5$ ; Row of zeros if  $K = 5$ . Therefore,  $4s^2 + 24 = 0$ . Hence,  $\omega = \sqrt{6}$  for oscillation.

37.

**Program:**

```
K=[0:0.001:200];
for i=1:length(K);
deng=conv([1 -4 8],[1 3]);
numg=[0 K(i) 2*K(i) 0];
dent=numg+deng;
R=roots(dent);
A=real(R);
```

```
B=max(A);
if B<0
R
K=K(i)
break
end
end
```

**Computer response:**

```
R =
-4.0000
-0.0000 + 2.4495i
-0.0000 - 2.4495i
```

```
K =
5
```

- a. From the computer response, (a) the range of K for stability is  $0 < K < 5$ .
- b. The system oscillates at  $K = 5$  at a frequency of 2.4494 rad/s as seen from R, the poles of the closed-loop system.

38.

$$T(s) = \frac{K(s+2)}{s^4 + 3s^3 - 3s^2 + (K+3)s + (2K-4)}$$

$s^4$	1	- 3	$2K-4$
$s^3$	3	$K+3$	0
$s^2$	$-\frac{K+12}{3}$	$2K-4$	0
$s^1$	$\frac{K(K+33)}{K+12}$	0	0
$s^0$	$2K-4$	0	0

For  $K < -33$ : 1 sign change; For  $-33 < K < -12$ : 1 sign change; For  $-12 < K < 0$ : 1 sign change; For  $0 < K < 2$ : 3 sign changes; For  $K > 2$ : 2 sign changes. Therefore,  $K > 2$  yields two right-half-plane poles.

39.

$$T(s) = \frac{K}{s^4 + 7s^3 + 15s^2 + 13s + (4+K)}$$

$s^4$	1	15	$K+4$
$s^3$	7	13	0
$s^2$	$\frac{92}{7}$	$K+4$	0
$s^1$	$\frac{1000-49K}{92}$	0	0
$s^0$	$K+4$	0	0

a. System is stable for  $-4 < K < 20.41$ .

b. Row of zeros when  $K = 20.41$ . Therefore,  $\frac{92}{7} s^2 + 24.41$ . Thus,  $s = \pm j1.3628$ , or  $\omega = 1.3628$  rad/s.

40.

$$T(s) = \frac{K}{s^3 + 53s^2 + 201s + (K + 245)}$$

$s^3$	1	201
$s^2$	53	$K+245$
$s^1$	$10408-K$	0
$s^0$	$K+245$	0

a. System is stable for  $-245 < K < 10408$ .

b. Row of zeros when  $K = 10408$ . Therefore,  $53s^2 + 10653$ . Thus,  $s = \pm j\sqrt{201}$ , or  $\omega = 14.18$  rad/s.

41.

$$T(s) = \frac{K}{s^4 + 8s^3 + 17s^2 + 10s + K}$$

$s^4$	1	17	$K$
$s^3$	8	10	0
$s^2$	$\frac{126}{8}$	$K$	0
$s^1$	$-\frac{32}{63}K + 10$	0	0
$s^0$	$K$	0	0

a. For stability  $0 < K < 19.69$ .

b. Row of zeros when  $K = 19.69$ . Therefore,  $\frac{126}{8} s^2 + 19.69$ . Thus,  $s = \pm j\sqrt{1.25}$ , or

$\omega = 1.118$  rad/s.

c. Denominator of closed-loop transfer function is  $s^4 + 8s^3 + 17s^2 + 10s + K$ . Substituting  $K = 19.69$  and solving for the roots yield  $s = \pm j1.118, -4.5, \text{ and } -3.5$ .

42.

$$T(s) = \frac{K(s^2 + 2s + 1)}{s^3 + 2s^2 + (K+1)s - K}$$

$s^3$	1	$K+1$
$s^2$	2	$-K$
$s^1$	$\frac{3K+2}{2}$	0
$s^0$	$-K$	0

Stability if  $-\frac{2}{3} < K < 0$ .

43.

$$T(s) = \frac{2s^4 + (K+2)s^3 + Ks^2}{s^3 + s^2 + 2s + K}$$

$s^3$	1	2
$s^2$	1	$K$
$s^1$	$2 - K$	0
$s^0$	$K$	0

Row of zeros when  $K = 2$ . Therefore  $s^2 + 2$  and  $s = \pm j\sqrt{2}$ , or  $\omega = 1.414$  rad/s. Thus  $K = 2$  will yield the even polynomial with  $2j\omega$  roots and no sign changes.

44.

	1	$K_2$	1
$s^3$	$K_1$	5	0
$s^2$	$\frac{K_1 K_2 - 5}{K_1}$	1	0
$s^1$	$\frac{K_1^2 - 5K_1 K_2 + 25}{5 - K_1 K_2}$	0	0
$s^0$	1	0	0

For stability,  $K_1K_2 > 5$ ;  $K_1^2 + 25 < 5K_1K_2$ ; and  $K_1 > 0$ . Thus  $0 < K_1^2 < 5K_1K_2 - 25$ ,  
 or  $0 < K_1 < \sqrt{5K_1K_2 - 25}$ .

45.

$s^4$	1	1	1
$s^3$	$K_1$	$K_2$	0
$s^2$	$\frac{K_1 - K_2}{K_1}$	1	0
$s^1$	$\frac{K_1^2 - K_1K_2 + K_2^2}{K_2 - K_1}$	0	0
$s^0$	1	0	0

For two  $j\omega$  poles,  $K_1^2 - K_1K_2 + K_2^2 = 0$ . However, there are no real roots. Therefore, there is no relationship between  $K_1$  and  $K_2$  that will yield just two  $j\omega$  poles.

46.

$s^8$	1	1.18E+03	2.15E+03	-1.06E+04	-415
$s^7$	103	4.04E+03	-8.96E+03	-1.55E+03	0
$s^6$	1140.7767	2236.99029	-10584.951	-415	0
$s^5$	3838.02357	-8004.2915	-1512.5299	0	0
$s^4$	4616.10784	-10135.382	-415	0	0
$s^3$	422.685462	-1167.4817	0	0	0
$s^2$	2614.57505	-415	0	0	0
$s^1$	-1100.3907	0	0	0	0
$s^0$	-415	0	0	0	0

a. From the first column, 1 rhp, 7 lhp, 0  $j\omega$ .

b.  $G(s)$  is not stable because of 1 rhp.

47.

$$K_1(s) = 2 + s + 6s^2 + s^3$$

$s^3$	1	1
$s^2$	6	2
$s$	$\frac{2}{3}$	
1	2	

No RHP roots

$$K_2(s) = 2 + 2s + 6s^2 + s^3$$

$s^3$	1	2
$s^2$	6	2
$s$	$\frac{5}{3}$	
1	2	

No RHP roots

$$K_3(s) = 4 + s + 4s^2 + s^3$$

$s^3$	1	1
$s^2$	4	4
$s$	8	
1	4	

Auxiliary equation  $Q(s) = 4s^2 + 4$ , no roots in RHP, but two roots in  $j\omega$  axis.

$$K_4(s) = 4 + 2s + 4s^2 + s^3$$

$s^3$	1	2
$s^2$	4	4
$s$	1	
1	4	

No RHP roots

The interval polynomial has no roots in the RHP.

48.

The characteristic equation for this system is:

$$1 + \frac{K}{m_T} \frac{s^2 + \omega_0^2}{s^2(s^2 + a\omega_0^2)} = 0 \text{ or } s^4 + (a\omega_0^2 + \frac{K}{m_T})s^2 + \frac{K\omega_0^2}{m_T} = 0$$

The Routh array is:

$s^4$	1	$(a\omega_0^2 + \frac{K}{m_T})$	$\frac{K\omega_0^2}{m_T}$
$s^3$	$\ominus 4$	$\ominus 2(a\omega_0^2 + \frac{K}{m_T})$	
$s^2$	$-2(a\omega_0^2 + \frac{K}{m_T})$	$\frac{K\omega_0^2}{m_T}$	
$s$	$\frac{4\frac{K\omega_0^2}{m_T} + 4(a\omega_0^2 + \frac{K}{m_T})^2}{(a\omega_0^2 + \frac{K}{m_T})^2}$		
1	$\frac{K\omega_0^2}{m_T}$		

The second row of zeros was substituted with the coefficients resulting from differentiating the characteristic equation:  $Q_a(s) = s^4 + (a\omega_0^2 + \frac{K}{m_T})s^2 + \frac{K\omega_0^2}{m_T}$  and

$$Q'_a(s) = 4s^3 + 2(a\omega_0^2 + \frac{K}{m_T})s.$$

Since all the plant parameters are positive, there are two sign changes in the first column of the Routh array. So there are two poles in the RHP, two must be in the LHP.

49.

The characteristic equation for the system is  $1 + \frac{K}{I_b s^2} = 0$  or  $s^2 + \frac{K}{I_b} = 0$ . The system has two complex conjugate poles at  $s = \pm j\sqrt{\frac{K}{I_b}}$ . The arm will oscillate at a frequency  $\sqrt{\frac{K}{I_b}}$  rad/sec.

50.

Eigenvalues are the roots of the following equation:

$$|s\mathbf{I} - \mathbf{A}| = \begin{vmatrix} s & 0 & 0 \\ 0 & s & 0 \\ 0 & 0 & s \end{vmatrix} - \begin{vmatrix} 0 & 1 & 3 \\ 2 & 2 & -4 \\ 1 & -4 & 3 \end{vmatrix} = \begin{vmatrix} s & -1 & -3 \\ -2 & s-2 & 4 \\ -1 & 4 & s-3 \end{vmatrix} = s^3 - 5s^2 - 15s + 40$$

Hence, eigenvalues are -3.2824, 1.9133, 6.3691. Therefore, 1 rhp, 2 lhp, 0 j $\omega$ .

51.

**Program:**

```
A=[0 1 0;0 1 -4;-1 1 8];
eig(A)
```

**Computer response:**

```
ans =
```

```
7.4641
0.5359
1.0000
```

52.

Writing the open-loop state and output equations we get,



$$\begin{aligned}\dot{x}_1 &= x_2 \\ \dot{x}_2 &= x_2 + 3x_3 \\ \dot{x}_3 &= -3x_1 - 4x_2 - 5x_3 + u \\ y &= x_2 + x_3\end{aligned}$$

Drawing the signal-flow diagram and including the unity feedback path yields,

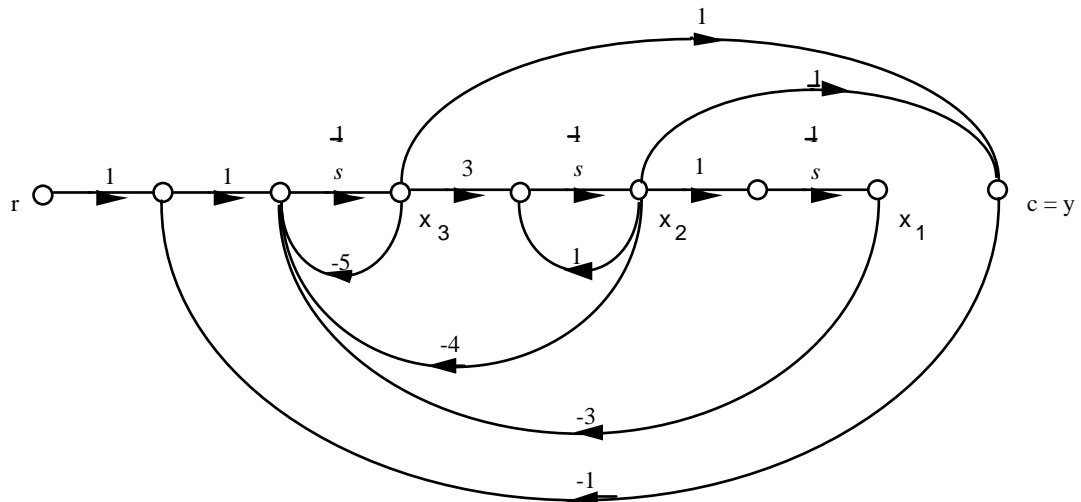

Writing the closed-loop state and output equations from the signal-flow diagram,

$$\begin{aligned}\dot{x}_1 &= x_2 \\ \dot{x}_2 &= x_2 + 3x_3 \\ \dot{x}_3 &= -3x_1 - 4x_2 - 5x_3 + r - c \\ &= -3x_1 - 4x_2 - 5x_3 + r - (x_2 + x_3) \\ &= -3x_1 - 5x_2 - 6x_3 + r \\ y &= x_2 + x_3\end{aligned}$$

In vector-matrix form,

$$\begin{aligned}\dot{\mathbf{x}} &= \begin{bmatrix} 0 & 1 & 0 \\ 0 & 1 & 3 \\ -3 & -5 & -6 \end{bmatrix} \mathbf{x} + \begin{bmatrix} 0 \\ 0 \\ 1 \end{bmatrix} r \\ y &= \begin{bmatrix} 0 & 1 & 1 \end{bmatrix} \mathbf{x}\end{aligned}$$

Now, find the characteristic equation.

$$\begin{aligned}
 |s\mathbf{I} - \mathbf{A}| &= \begin{vmatrix} s & 0 & 0 \\ 0 & s & 0 \\ 0 & 0 & s \end{vmatrix} - \begin{vmatrix} 0 & 1 & 0 \\ 0 & 1 & 3 \\ -3 & -5 & -6 \end{vmatrix} = \begin{vmatrix} s & -1 & 0 \\ 0 & (s-1) & -3 \\ 3 & 5 & (s+6) \end{vmatrix} \\
 &= s^3 + 5s^2 + 9s + 9
 \end{aligned}$$

Forming a Routh table to determine stability

$s^3$	1	9
$s^2$	5	9
$s^1$	$\frac{36}{5}$	0
$s^0$	9	0

Since there are no sign changes, the closed-loop system is stable.

53.

**Program:**

```

A=[0,1,0;0,1,3;-3,-4,-5];
B=[0;0;1];
C=[0,1,1];
D=0;
'G'
G=ss(A,B,C,D)
'T'
T=feedback(G,1)
'Eigenvalues of T'
ssdata(T);
eig(T)

```

**Computer response:**

ans =

G

a =

	x1	x2	x3
x1	0	1	0
x2	0	1	3
x3	-3	-4	-5

b =

	u1
x1	0
x2	0
x3	1

c =

	x1	x2	x3
y1	0	1	1

$$d = \begin{matrix} & u1 \\ y1 & 0 \end{matrix}$$

Continuous-time model.

ans =

T

$$a = \begin{matrix} & x1 & x2 & x3 \\ x1 & 0 & 1 & 0 \\ x2 & 0 & 1 & 3 \\ x3 & -3 & -5 & -6 \end{matrix}$$

$$b = \begin{matrix} & u1 \\ x1 & 0 \\ x2 & 0 \\ x3 & 1 \end{matrix}$$

$$c = \begin{matrix} & x1 & x2 & x3 \\ y1 & 0 & 1 & 1 \end{matrix}$$

$$d = \begin{matrix} & u1 \\ y1 & 0 \end{matrix}$$

Continuous-time model.

ans =

Eigenvalues of T

ans =

$$\begin{matrix} -1.0000 + 1.4142i \\ -1.0000 - 1.4142i \\ -3.0000 \end{matrix}$$

54.

a. For  $n = 1$ ,  $B_1(s) = 1 - \frac{s^2}{\omega_c^2} = 0$  or  $-s^2 + \omega_c^2 = 0$ . The Routh array is

$s^2$	-1	$\omega_c^2$
$s$	$\theta - 2$	
1	$\omega_c^2$	

The auxiliary polynomial used in the second row is  $Q_a(s) = -s^2 + \omega_c^2$ , that row is replaced with the coefficients of  $Q'_a(s) = -2s$ .

The first column has one sign change, so there is one root in the RHP, one in the LHP.

b. For  $n = 2$ ,  $B_2(s) = 1 - \frac{s^4}{\omega_c^4} = 0$  or  $s^4 + \omega_c^4 = 0$ . The Routh array is

$s^4$	1	0	$\omega_c^4$
$s^3$	0	4	0
$s^2$	0	$\varepsilon$	$\omega_c^4$
$s$	$-\frac{4\omega_c^4}{\varepsilon}$		
1	$\omega_c^4$		

The second row was originally a row of zeros, the auxiliary equation used was  $Q_a(s) = s^4 + \omega_c^4$ , so its coefficients were substituted with the coefficients of  $Q'_a(s) = 4s^3$ .

The first column in the array has two sign changes, so the polynomial has two roots in the RHP and two must be in the LHP.

## SOLUTIONS TO DESIGN PROBLEMS

55.

$$T(s) = \frac{K(s+1)(s+10)}{s^3 + (5.45+K)s^2 + (11.91+11K)s + (43.65+10K)}$$

$s^3$	1	11.91+11K
$s^2$	5.45+K	43.65+10K
$s^1$	$\frac{11K^2 + 61.86K + 21.26}{5.45+K}$	0
$s^0$	43.65+10K	0

For stability,  $-0.36772 < K < \infty$ . Stable for all positive K.

56.

$$T(s) = \frac{0.7K(s+0.1)}{s^4 + 2.2s^3 + 1.14s^2 + 0.193s + (0.07K+0.01)}$$

$s^4$	1	1.14	$0.07K+0.01$
$s^3$	2.2	0.193	0
$s^2$	1.0523	$0.07K+0.01$	0
$s^1$	$0.17209 - 0.14635K$	0	0
$s^0$	$0.07K+0.01$	0	0

For stability,  $-0.1429 < K < 1.1759$

57.

$$T(s) = \frac{0.6K + 10Ks^2 + 60.1Ks}{s^5 + 130s^4 + 3229s^3 + 10(K + 2348)s^2 + (60.1K + 58000)s + 0.6K}$$

$s^5$	1	3229	$60.1K+58000$
$s^4$	130	$10K+23480$	$0.6K$
$s^3$	$-10K+396290$	$7812.4K+7540000$	0
$s^2$	$\frac{-100K^2+2712488K+8.3247E9}{-10K+396290}$	$0.6K$	0
$s^1$	$\frac{7813E3K^4-5.1401E11K^3+7.2469E15K^2+3.3213E19K+2.4874E22}{1000K^3-66753880K^2+9.9168E11K+3.299E15}$	0	0
$s^0$	$0.6K$	0	0

Note:  $s^3$  row was multiplied by 130

From  $s^1$  row after canceling common roots:

$$\frac{7813000(K - 39629)(K + 967.31586571671)(K + 2776.9294183336)(K - 29908.070615165)}{1000(K - 39629)(K + 2783.405672635)(K - 29908.285672635)}$$

From  $s^0$  row:  $K > 0$

From  $s^3$  row:  $K < 39629$

From  $s^2$  row:  $K < 29908.29$ ;  $39629 < K$

From  $s^1$  row:  $29908.29 < K$ , or  $K < 29908.07$ ;

Therefore, for stability,  $0 < K < 29908.07$

58.

$s^5$	1	1311.2	$1000(100K+1)$
$s^4$	112.1	10130	60000K
$s^3$	1220.8	$99465K+1000$	0
$s^2$	$10038-9133.4K$	60000K	0
$s^1$	$\frac{99465(K+0.010841)(K-1.0192)}{(K-1.0991)}$	0	0
$s^0$	60000K	0	0

From  $s^2$  row:  $K < 1.099$

From  $s^1$  row:  $-0.010841 < K < 1.0192$ ;  $K > 1.0991$

From  $s^0$  row:  $0 < K$

Therefore,  $0 < K < 1.0192$

59.

Find the closed-loop transfer function.

$$G(s) = \frac{63 \times 10^6 K}{(s+30)(s+140)(s+2.5)}$$

$$T(s) = \frac{G(s)}{1+G(s)H(s)} = \frac{63 \times 10^6 K}{s^3 + 172.5s^2 + 4625s + (10500 + 63 \times 10^6 K)}$$

Make a Routh table.

$s^3$	1	4625
$s^2$	172.5	$10500+63 \times 10^6 K$
$s^1$	$4564.13-365217.39K$	0
$s^0$	$10500+63 \times 10^6 K$	0

The  $s^1$  line says  $K < 1.25 \times 10^{-2}$  for stability. The  $s^0$  line says  $K > -1.67 \times 10^{-4}$  for stability.

Hence,  $-1.67 \times 10^{-4} < K < 1.25 \times 10^{-2}$  for stability.

60.

Find the closed-loop transfer function.

$$G(s) = \frac{7570Kp(s+103)(s+0.8)}{s(s+62.61)(s-62.61)}$$

$$T(s) = \frac{G(s)}{1+G(s)H(s)} = \frac{7570Kp(s+103)(s+0.8)}{s^3 + 7570K_p s^2 + (785766K_p - 3918.76)s + 623768K_p}$$

Make a Routh table.

$s^3$	1	$785766K_p - 3918.76$
$s^2$	7570	$623768K_p$
$s^1$	$785766K_p - 4001.16$	0
$s^0$	$623768K_p$	0

The  $s^1$  line says  $K_p > 5.09 \times 10^{-3}$  for stability. The  $s^0$  line says  $K_p > 0$  for stability.

Hence,  $K_p > 5.09 \times 10^{-3}$  for stability.

61.

The characteristic equation is given by:

$$1 + K \frac{1 \times 10^{-6} s^2 + 1.314 \times 10^{-9} s + 2.66 \times 10^{-13}}{s^3 + 0.00163 s^2 + 5.272 \times 10^{-7} s + 3.538 \times 10^{-11}} = 0$$

Or

$$s^3 + (0.00163 + 1 \times 10^{-6} K) s^2 + (5.272 \times 10^{-7} + 1.314 \times 10^{-9} K) s + (3.538 \times 10^{-11} + 2.66 \times 10^{-13} K) = 0$$

The corresponding Routh array is:

$s^3$	1	$5.272 \times 10^{-7} + 1.314 \times 10^{-9} K$
$s^2$	$0.00163 + 1 \times 10^{-6} K$	$3.538 \times 10^{-11} + 2.66 \times 10^{-13} K$
$s$	$\frac{1.314 \times 10^{-15} (K + 1371.6)(K + 457.8)}{0.00163 + 1 \times 10^{-6} K}$	
1	$3.538 \times 10^{-11} + 2.66 \times 10^{-13} K$	

For stability row 2 requires  $K > -1630$  and row 4 requires  $K > -133.008$ . The dominant requirement being the latter. It is clear also that when  $K > -133.008$ , the first element on row 3 is positive. So the overall requirement for stability is  $K > -133.008$ .

**62.**

The characteristic equation of the system is given by:

$$1 + \frac{K_C}{ms^2 + bs + k} - \frac{K_C}{K_f} \frac{1}{Ts + 1} = 0 \text{ or}$$

$$K_f(ms^2 + bs + k)(Ts + 1) + K_f K_C(Ts + 1) - K_C(ms^2 + bs + k) = 0 \text{ or}$$

$$K_f(ms^2 + bs + k)(Ts + 1) + K_f K_C(Ts + 1) - K_C(ms^2 + bs + k) = 0 \text{ or}$$

$$K_f(mTs^3 + (bT + m)s^2 + (kT + b)s + k) + K_f K_C(Ts + 1) - K_C(ms^2 + bs + k) = 0 \text{ or}$$

$$K_f mTs^3 + [K_f(bT + m) - K_C m]s^2 + [K_f(kT + b) + K_f K_C T - K_C b]s + [k + K_f K_C - K_C k] = 0$$

Substituting numerical values the equation becomes:

$$5.28 \times 10^{-6} K_f s^3 + [0.03444 K_f - 1.8]s^2 + [1584.78 K_f - 11700]s + [22500 K_f - 31.5 \times 10^6] = 0$$

The Routh array is given by

$s^3$	$5.28 \times 10^{-6} K_f$	$1584.78 K_f - 11700$
$s^2$	$0.03444 K_f - 1.8$	$22500 K_f - 31.5 \times 10^6$
$s$	$\frac{5.28 \times 10^{-6} [22500 K_f - 31.5 \times 10^6] - [1584.78 K_f - 11700] [0.03444 K_f - 1.8]}{-[0.03444 K_f - 1.8]}$	
1	$22500 K_f - 31.5 \times 10^6$	

To obtain positive quantities on the first column it is required:

$$5.28 \times 10^{-6} K_f > 0 \Rightarrow K_f > 0$$

$$0.03444 K_f - 1.8 > 0 \Rightarrow K_f > 52.26$$

$$22500 K_f - 31.5 \times 10^6 > 0 \Rightarrow K_f > 1400$$



$$[1584.78K_f - 11700][0.03444K_f - 1.8] - 5.28 \times 10^{-6} [22500K_f - 31.5 \times 10^6] > 0$$

or

$$54.52K_f^2 - 402.48K_f - 2852.6K_f + 21060 > 0.1188K_f^2 - 166.32K_f$$

or

$$54.4K_f^2 - 3088.76K_f + 21060 > 0$$

or

$$K_f^2 - 56.8K_f + 387.1 > 0$$

or

$$(K_f - 7.92)(K_f - 48.88) > 0$$

So either  $K_f < 7.92$  and  $K_f < 48.88 \Rightarrow K_f < 7.92$

or  $K_f > 7.92$  and  $K_f > 48.88 \Rightarrow K_f > 7.92$

The most dominant requirement is given by the fourth row. We conclude requiring  $K_f > 1400$ .

**63.**

a. The Mesh equations obtained by defining clockwise mesh currents are given by

$I_1 :$	$(\frac{1}{sC} + R)I_1 - RI_2 = V_1$
$I_2 :$	$-RI_1 + (2R + \frac{1}{sC})I_2 - RI_3 = 0$
$I_3 :$	$-RI_2 + (2R + \frac{1}{sC})I_3 = 0$

Solving for  $I_3$ ,

$$I_3 = \frac{\begin{vmatrix} \frac{1}{sC} + R & -R & V_1 \\ -R & 2R + \frac{1}{sC} & 0 \\ 0 & -R & 0 \end{vmatrix}}{\begin{vmatrix} \frac{1}{sC} + R & -R & 0 \\ -R & 2R + \frac{1}{sC} & -R \\ 0 & -R & 2R + \frac{1}{sC} \end{vmatrix}} = \frac{-R^2 V_1}{\left(\frac{1}{sC} + R\right)\left(2R + \frac{1}{sC}\right)^2 - 3R^3 - \frac{2R^2}{sC}}$$

$$V_2 = RI_3 = \frac{-R^3 V_1}{\left(\frac{1}{sC} + R\right)\left(2R + \frac{1}{sC}\right)^2 - 3R^3 - \frac{2R^2}{sC}}$$

$$\frac{V_2}{V_1} = \frac{-1}{\left(1 + \frac{1}{sRC}\right)\left(2 + \frac{1}{sRC}\right)^2 - 3 - \frac{2}{sRC}}$$

b. The gain of the inverting amplifier is given by:  $\frac{V_1}{V_2} = -\frac{R_2}{R_1}$  or  $\frac{V_2}{V_1} = -\frac{R_1}{R_2} = -\frac{1}{K}$ . Equating to

the transfer function obtained in Part a

$$-\frac{1}{K} = \frac{-1}{\left(1 + \frac{1}{sRC}\right)\left(2 + \frac{1}{sRC}\right)^2 - 3 - \frac{2}{sRC}}. \text{ Equivalently}$$

$$1 - \frac{K}{\left(1 + \frac{1}{sRC}\right)\left(2 + \frac{1}{sRC}\right)^2 - 3 - \frac{2}{sRC}} = 0$$

c. The characteristic equation can be written as:

$$\left(1 + \frac{1}{sRC}\right)\left(2 + \frac{1}{sRC}\right)^2 - 3 - \frac{2}{sRC} - K = 0 \text{ or}$$

$$\frac{1}{s^3 R^3 C^3} + \frac{5}{s^2 R^2 C^2} + \frac{6}{sRC} + 1 - K = 0 \text{ or}$$

$$(1 - K)s^3 R^3 C^3 + 6s^2 R^2 C^2 + 5sRC + 1 = 0$$

The Routh array is given by

$s^3$	$(1-K)R^3C^3$	$5RC$
$s^2$	$6R^2C^2$	1
$s$	$\frac{(29-K)RC}{8}$	
1	1	

So for oscillation it is required to have  $K=29$ . The resulting auxiliary equation is

$$Q(s) = 6R^2C^2s^2 + 1. \text{ Solving the latter for the } j\omega\text{-axis poles we obtain } s = \pm j\frac{1}{\sqrt{6RC}}. \text{ The}$$

$$\text{oscillation frequency is } f = \frac{1}{2\pi\sqrt{6RC}}.$$

64.

For simplification we substitute parameter values into the open loop transfer function. It becomes:

$$G(s) = \frac{K_p s + K_I}{s^2} \frac{80784s^2 + 4322.8s + 1}{545760}$$

The characteristic equation  $1 + G(s) = 0$  becomes:

$$1 + \frac{K_p s + K_I}{s^2} \frac{80784s^2 + 4322.8s + 1}{545760} = 0 \text{ or } 545760s^2 + (K_p s + K_I)(80784s^2 + 4322.8s + 1) = 0$$

Or

$$80784 K_p s^3 + (4322.8K_p + 80784K_I + 545760)s^2 + (K_p + 4322.8K_I)s + K_I = 0$$

The Routh array becomes:

$s^3$	$80784 K_p$	$K_p + 4322.8K_I$
$s^2$	$4322.8K_p + 80784K_I + 545760$	$K_I$
$s$	$\frac{4322.8K_p^2 + 545760K_p + 18686599.84K_p K_I + 349213075.2K_I^1 + 2359211328K_I}{4322.8K_p + 80784K_I + 545760}$	
1	$K_I$	

It is clear from the array that the entries in the first column will be positive for all  $K_p \gg 0, K_I \gg 0$

65.

First, find the transfer function of the internal (flow-control) loop,  $G_{WF}(s) = \frac{Q_w(s)}{X(s)}$ , then the

$$\text{overall transfer function } T(s) = \frac{C(s)}{R(s)} = \frac{G_{LC}(s) \cdot G_{WF}(s) \cdot G_{fw}(s)}{1 + G_{LC}(s) \cdot G_{WF}(s) \cdot G_{fw}(s)}$$

The transfer function of the internal (flow-control) feedback loop in figure 2 is:

$$G_{WF}(s) = \frac{Q_w(s)}{X(s)} = \frac{G_{FC}(s) \times G_V(s)}{1 + G_{FC}(s) \times G_V(s)} = \frac{\frac{0.5 + 2s}{3s + 1}}{1 + \frac{0.5 + 2s}{3s + 1}} = \frac{0.5 + 2s}{1.5 + 5s}$$

Thus, the overall system transfer function is:

$$\begin{aligned} T(s) &= \frac{C(s)}{R(s)} = \frac{G_{LC}(s) \cdot G_{WF}(s) \cdot G_{fw}(s)}{1 + G_{LC}(s) \cdot G_{WF}(s) \cdot G_{fw}(s)} = \frac{(0.5 + Ks) \left( \frac{0.5 + 2s}{1.5 + 5s} \right) \left[ \frac{2}{s(25s + 1)(2s^2 + 2s + 1)} \right]}{1 + (0.5 + Ks) \left( \frac{0.5 + 2s}{1.5 + 5s} \right) \left[ \frac{2}{s(25s + 1)(2s^2 + 2s + 1)} \right]} \\ &= \frac{(Ks + 0.5) \times (4s + 1)}{s \times (5s + 1.5) \times (25s + 1) \times (2s^2 + 2s + 1) + (Ks + 0.5) \times (4s + 1)} \\ &= \frac{(Ks + 0.5) \times (4s + 1)}{(125s^3 + 42.5s^2 + 1.5s) \times (2s^2 + 2s + 1) + (Ks + 0.5) \times (4s + 1)} \end{aligned}$$

The characteristic polynomial is, therefore:

$$\begin{aligned} P(s) &= (125s^3 + 42.5s^2 + 1.5s)(2s^2 + 2s + 1) + (Ks + 0.5) \times (4s + 1) = \\ &= 250s^5 + 335s^4 + 213s^3 + (45.5 + 4K)s^2 + (3.5 + K)s + 0.5 \end{aligned}$$

Hence, the Routh-Hurwitz array for the system is given by:

$s^5$	250	213	$3.5 + K$	0
$s^4$	335	$45.5 + 4K$	0.5	0
$s^3$	$335 \times 213 - 250 \times (45.5 + 4K)^{\#}$	$335(3.5 + K) - 125$	0	
$s^2$	$C$	0.5	0	
$s^1$	$\frac{C[335(3.5 + K) - 125] - 0.5 \times [335 \times 213 - 250 \times (45.5 + 4K)]}{C}$	0		
$s^0$	0.5			

From the  $s^3$  row:  $335 \times 213 - 250 \times (45.5 + 4K) > 0$ , therefore  $K < 59.98$  (4)

From the  $s^2$  row:  $C = \frac{[335 \times 213 - 250(45.5 + 4K)] \times (45.5 + 4K) - 335 \times [335(3.5 + K) - 125]}{335 \times 213 - 250(45.5 + 4K)} > 0$ .

Therefore:  $[335 \times 213 - 250(45.5 + 4K)] \times (45.5 + 4K) - 335 \times [335(3.5 + K) - 125] > 0$ .

This inequality may be expanded to:

$$[59980 - 1000K] \times (45.5 + 4K) - 112225K - 392787.5 + 41875 =$$

$$-4000K^2 + 82195K + 2378177.5 > 0, \text{ or } (K - 36.7339) \times (K + 16.1852) < 0 \text{ which}$$

shows that for stability:

$$K < 36.73$$

For  $C > 0$ , the  $s^1$  row  $\frac{C[335(3.5 + K) - 125] - 0.5 \times [335 \times 213 - 250 \times (45.5 + 4K)]}{C}$  is

greater than 0 if:

---

<sup>#</sup> The  $s^3$  row was multiplied by 335 and the  $s^1$  row was multiplied by  $C$ .

$$[335(3.5 + K) - 125] - \frac{0.5 \times [335 \times 213 - 250 \times (45.5 + 4K)]}{C} > 0$$

This inequality may be re-written as:

$$[335(3.5 + K) - 125] - \frac{0.5 \times [335 \times 213 - 250 \times (45.5 + 4K)]^2}{[335 \times 213 - 250(45.5 + 4K)] \times (45.5 + 4K) - 335 \times [335(3.5 + K) - 125]} > 0$$

After algebraic manipulations this can be rewritten as:

$$-1340000K^3 + 22845325K^2 + 942768725K + 6.9234 \times 10^8 > 0$$

or

$$(K + 0.7485)(K + 18.84)(K - 36.7) < 0$$

From the previous, and for positive  $K$ , we conclude that the system will be stable only if level controller's derivative gain,  $K_{D_{LC}}$  is within the range:  $0 < K_{D_{LC}} < 36.7$ .

66.

$$s\mathbf{I} - \mathbf{A} = \begin{bmatrix} s + 11.7 & -6.8 & -61.6K & -7.7K \\ 3.5 & s + 24 & 66.9K & -8.4K \\ 0 & -1 & s & 0 \\ -1 & 0 & 10 & s \end{bmatrix}$$

$$\det(s\mathbf{I} - \mathbf{A}) = (s + 11.7) \begin{vmatrix} s + 24 & 66.9K & -8.4K \\ -1 & s & 0 \\ 0 & 10 & s \end{vmatrix} + 6.8 \begin{vmatrix} 3.5 & 66.9K & -8.4K \\ 0 & s & 0 \\ -1 & 10 & s \end{vmatrix}$$

$$- 61.6K \begin{vmatrix} 3.5 & 66.9K & -8.4K \\ 0 & -1 & 0 \\ -1 & 0 & s \end{vmatrix} + 7.7K \begin{vmatrix} 3.5 & s + 24 & 66.9K \\ 0 & -1 & s \\ -1 & 0 & 10 \end{vmatrix}$$

$$\begin{aligned}
 &= (s + 11.7) \left\{ (s + 24) \begin{vmatrix} s & 0 \\ 10 & s \end{vmatrix} - 66.9K \begin{vmatrix} -1 & 0 \\ 0 & s \end{vmatrix} - 8.4K \begin{vmatrix} -1 & s \\ 0 & 10 \end{vmatrix} \right\} \\
 &+ 6.8 \left\{ 3.5 \begin{vmatrix} s & 0 \\ 10 & s \end{vmatrix} - 66.9K \begin{vmatrix} 0 & 0 \\ -1 & s \end{vmatrix} - 8.4K \begin{vmatrix} -1 & s \\ 0 & 10 \end{vmatrix} \right\} \\
 &- 61.6K \left\{ 3.5 \begin{vmatrix} -1 & 0 \\ 0 & s \end{vmatrix} - 66.9K \begin{vmatrix} 0 & 0 \\ -1 & s \end{vmatrix} - 8.4K \begin{vmatrix} 0 & -1 \\ -1 & 0 \end{vmatrix} \right\} \\
 &+ 7.7K \left\{ 3.5 \begin{vmatrix} -1 & s \\ 0 & 10 \end{vmatrix} - (s + 24) \begin{vmatrix} 0 & s \\ -1 & 10 \end{vmatrix} + 66.9K \begin{vmatrix} 0 & -1 \\ -1 & 0 \end{vmatrix} \right\} \\
 &= s^4 + 35.7s^3 + (304.6 + 59.2K)s^2 + 840.41Ks + 713.3K - 1032.57K^2 = 0
 \end{aligned}$$

The Routh array is:

$s^4$	1	$304.6 + 59.2K$	$713.3K$
$s^3$	35.7	$840.41K$	$-1032.57K^2$
$s^2$	$35.66K + 304.6$	$28.92K^2 + 713.3K$	
$s$	$\frac{28936.58K^2 + 230524.08K}{35.66K + 304.6}$		
1	$28.92K^2 + 713.3K$		

Row 3 is positive if  $K > -8.54$

Rows 4 and 5 are positive if  $K > 0$

So the system is closed loop stable if  $K > 0$ .

67.

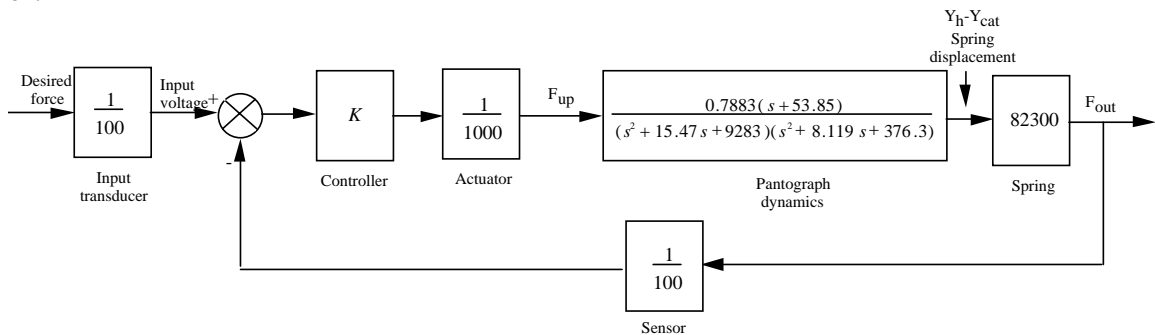

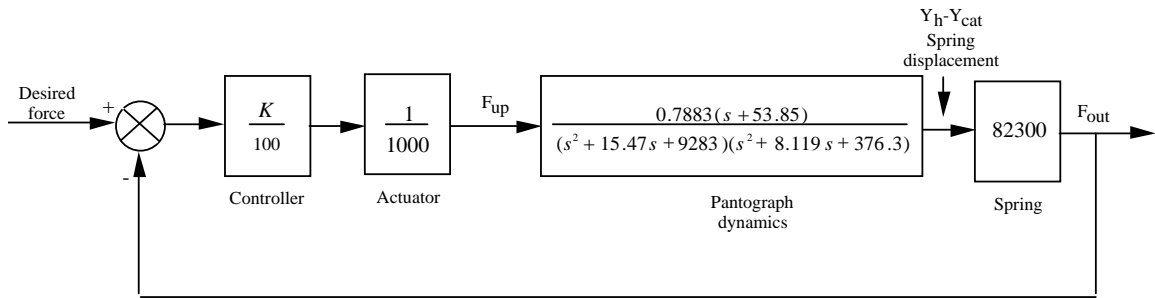

$$G(s) = \frac{Y_h(s) - Y_{cat}(s)}{F_{up}(s)} = \frac{0.7883(s + 53.85)}{(s^2 + 15.47s + 9283)(s^2 + 8.119s + 376.3)}$$

$$G_e(s) = (K/100) * (1/1000) * G(s) * 82.3e3$$

$$G_e(s) = \frac{0.6488K(s + 53.85)}{(s^2 + 8.119s + 376.3)(s^2 + 15.47s + 9283)}$$

$$T(s) = \frac{0.6488K(s + 53.85)}{s^4 + 23.589s^3 + 9784.90093s^2 + (0.6488K + 81190.038)s + (34.94K + 0.3493192910)}$$

$s^4$	1	9785	$(0.3493e7 + 34.94K)$	+
$s^3$	23.59	$(0.6488K + 81190)$	0	+
$s^2$	$(-0.0275K + 6343)$	$(0.3493e7 + 34.94K)$	0	$K < 230654$
$s^1$	$\frac{-0.0178K^2 + 10587K + 432.59e6}{-0.0275K + 6343}$		0	$-128966 < K < 188444$
$s^0$	$(0.3493e7 + 34.94K)$		0	$-99971 < K$

The last column evaluates the range of  $K$  for stability for each row. Therefore  $-99971 < K < 188444$ .



68.

The Characteristic Equation is given by

$$1 + K \frac{-520s - 10.3844}{s^3 + 2.6817s^2 + 0.11s + 0.0126} = 0$$

or

$$s^3 + 2.6817s^2 + 0.11s + 0.0126 - K(520s + 10.3844) = 0$$

or

$$s^3 + 2.6817s^2 + (0.11 - 520K)s + (0.0126 - 10.3844K) = 0$$

The Routh Array is:

$s^3$	1	$0.11 - 520K$
$s^2$	2.6817	$0.0126 - 10.3844K$
$s$	$\frac{0.2824 - 1384.1K}{2.6817}$	
1	$0.0126 - 10.3844K$	

Thus for stability

$$\frac{0.2824 - 1384.1K}{2.6817} > 0 \text{ or } K < 2.04 \times 10^{-4}$$

and

$$0.0126 - 10.3844K > 0 \text{ or } K < 1.21 \times 10^{-3}$$

The intersection of both requirements gives  $K < 2.04 \times 10^{-4}$ .

69.

From the block diagram it is readily obtained:

$$\frac{\Omega(s)}{R_v(s)} = \frac{\left( \frac{K_p s + 40}{s} \right) \left( \frac{0.2491 \times (10s + 6)}{s(s + 0.5173) + 0.5 \times (10s + 6) \times (s + 0.01908)} \right)}{1 + 0.0443 \left( \frac{K_p s + 40}{s} \right) \left( \frac{0.2491 \times (10s + 6)}{s(s + 0.5173) + 0.5 \times (10s + 6) \times (s + 0.01908)} \right)} \text{ or}$$

$$\frac{\Omega(s)}{R_v(s)} = \frac{2.491 (K_p s + 40) (s + 0.6)}{s(6s^2 + 3.613s + 0.0572) + 0.11035 [K_p s^2 + (40 + 0.6K_p)s + 24]}$$

$$= \frac{2.491(K_p s + 40)(s + 0.6)}{6s^3 + (3.613 + 0.11035K_p)s^2 + (4.4712 + 0.06621K_p)s + 2.65}$$

Noting that the change in car speed,  $v = \frac{r}{i_{tot}} \omega = 0.06154 \omega$ , we get the system transfer function,  $T(s) =$

$V(s)/R_v(s)$ :

$$\frac{V(s)}{R_v(s)} = 0.06154 \frac{\Omega(s)}{R_v(s)} = \frac{0.1533 (s + 40) (s + 0.6)}{6s^3 + (3.613 + 0.11035K_p)s^2 + (4.4712 + 0.06621K_p)s + 2.65}$$

The characteristic polynomial for that system is, therefore:

$$P(s) = 6s^3 + (3.613 + 0.11035K_p)s^2 + (4.4712 + 0.06621K_p)s + 2.65$$

Hence, the Routh-Hurwitz for the system is given by:

$s^3$	6	$4.4712 + 0.06621K_p$	0
$s^2$	$3.613 + 0.11035K_p$	2.65	0
$s^1$	$\frac{(3.613 + 0.11035K_p)(4.4712 + 0.06621K_p) - 15.9}{3.613 + 0.11035K_p}$	0	0
$s^0$	2.65	0	0

For stability,  $3.613 + 0.11035K_p \geq 0 \Rightarrow K_p \geq -32.74$  and

$(3.613 + 0.11035 K_p)(4.4712 + 0.06621 K_p) - 15.9 \geq 0$ . That is:

$$0.00731 K_p^2 + 0.73261 K_p + 0.2544456 = 0.00731(K_p^2 + 100.22 K_p + 34.81) \Rightarrow$$

$$(K_p^2 + 100.22 K_p + 34.81) = (K_p + 99.872)(K_p + 0.348) \geq 0$$

The latter condition indicates that for stability  $K_p \geq -99.872$  and  $K_p \geq -0.348$

The intersection of these two requirements shows that for stability:  $K_p \geq -0.348$  or, alternatively  $K_{p_{sc}} > 0$ .

# S E V E N

## Steady-State Errors

### SOLUTIONS TO CASE STUDIES CHALLENGES

#### Antenna Control: Steady-State Error Design via Gain

a.  $G(s) = \frac{76.39K}{s(s+150)(s+1.32)}$ . System is Type 1. Step input:  $e(\infty) = 0$ ; Ramp input:

$$e(\infty) = \frac{1}{K_v} = \frac{1}{\frac{76.39K}{150 \times 1.32}} = \frac{2.59}{K}; \text{ Parabolic input: } e(\infty) = \infty.$$

b.  $\frac{1}{K_v} = \frac{2.59}{K} = 0.2$ . Therefore,  $K = 12.95$ . Now test the closed-loop transfer function,

$$T(s) = \frac{989.25}{s^3 + 151.32s^2 + 198s + 989.25}, \text{ for stability. Using Routh-Hurwitz, the system is stable.}$$

$s^3$	1	198
$s^2$	151.32	989.25
$s^1$	191.46253	0
$s^0$	989.25	0

#### Video Laser Disc Recorder: Steady-State Error Design via Gain

a. The input,  $15t^2$ , transforms into  $30/s^3$ .  $e(\infty) = 30/K_a = 0.005$ .

$$K_a = \frac{0.2 \cdot 600}{20000} * K_1 K_2 K_3 = 6 \times 10^{-3} K_1 K_2 K_3. \text{ Therefore: } e(\infty) = 30/K_a = \frac{30}{6 \times 10^{-3} K_1 K_2 K_3}$$

$= 5 \times 10^{-3}$ . Therefore  $K_1 K_2 K_3 = 10^6$ .

b. Using  $K_1 K_2 K_3 = 10^6$ ,  $G(s) = \frac{2 \times 10^5 (s + 600)}{s^2 (s + 2 \times 10^4)}$ . Therefore,  $T(s) =$

$$\frac{2 \times 10^5 (s + 600)}{s^3 + 2 \times 10^4 s^2 + 2 \times 10^5 s + 1.2 \times 10^8}.$$

Making a Routh table,

$s^3$	1	$2 \times 10^5$
$s^2$	$2 \times 10^4$	$1.2 \times 10^8$
$s^1$	194000	0
$s^0$	120000000	0

we see that the system is stable.

**c.**

**Program:**

```
numg=200000*[1 600];
deng=poly([0 0 -20000]);
G=tf(numg,deng);
'T(s)'
T=feedback(G,1)
poles=pole(T)
```

**Computer response:**

ans =

T(s)

Transfer function:

$$\frac{200000 s + 1.2e008}{s^3 + 20000 s^2 + 200000 s + 1.2e008}$$

poles =

```
1.0e+004 *
-1.9990
-0.0005 + 0.0077i
-0.0005 - 0.0077i
```

## ANSWERS TO REVIEW QUESTIONS

1. Nonlinear, system configuration
2. Infinite
3. Step(position), ramp(velocity), parabola(acceleration)
4. Step(position)-1, ramp(velocity)-2, parabola(acceleration)-3
5. Decreases the steady-state error
6. Static error coefficient is much greater than unity.
7. They are exact reciprocals.
8. A test input of a step is used; the system has no integrations in the forward path; the error for a step input is 1/10001.
9. The number of pure integrations in the forward path

10. Type 0 since there are no poles at the origin
11. Minimizes their effect
12. If each transfer function has no pure integrations, then the disturbance is minimized by decreasing the plant gain and increasing the controller gain. If any function has an integration then there is no control over its effect through gain adjustment.
13. No
14. A unity feedback is created by subtracting one from  $H(s)$ .  $G(s)$  with  $H(s)-1$  as feedback form an equivalent forward path transfer function with unity feedback.
15. The fractional change in a function caused by a fractional change in a parameter
16. Final value theorem and input substitution methods

## SOLUTIONS TO PROBLEMS

1.

$$e(\infty) = \lim_{s \rightarrow 0} s E(s) = \lim_{s \rightarrow 0} \frac{s R(s)}{1+G(s)}$$

where

$$G(s) = \frac{450(s+12)(s+8)(s+15)}{s(s+38)(s^2+2s+28)}$$

For step,  $e(\infty) = 0$ . For  $37tu(t)$ ,  $R(s) = \frac{37}{s^2}$ . Thus,  $e(\infty) = 6.075 \times 10^{-2}$ . For parabolic input,  $e(\infty) = \infty$ .

2.

a. From the figure  $e_{ss} = r_{ss} - c_{ss} = 5 - 3 = 2$

b. Since the system is linear, and because the original input was  $r(t) = 2.5tu(t)$ , the new steady state error is  $e_{ss} = \frac{2}{2.5} = 0.8$ .

3.

$$\begin{aligned} e(\infty) &= \lim_{s \rightarrow 0} s E(s) = \lim_{s \rightarrow 0} \frac{s R(s)}{1+G(s)} \\ &= \lim_{s \rightarrow 0} \frac{s(160/s^3)}{1 + \frac{60(s+3)(s+4)(s+8)}{s^2(s+6)(s+17)}} = 2.83 \end{aligned}$$

4.

Reduce the system to an equivalent unity feedback system by first moving  $1/s$  to the left past the summing junction. This move creates a forward path consisting of a parallel pair,  $\left(\frac{1}{s} + 1\right)$  in cascade with a feedback loop consisting of  $G(s) = \frac{2}{s+3}$  and  $H(s) = 7$ . Thus,

$$G_e(s) = \left(\frac{s+1}{s}\right) \left(\frac{2/(s+3)}{1+14/(s+3)}\right) = \frac{2(s+1)}{s(s+17)}$$

Hence, the system is Type 1 and the steady-state errors are as follows:

Steady-state error for  $15u(t) = 0$ .

Steady-state error for  $15tu(t) = \frac{15}{K_v} = \frac{15}{2/17} = 127.5$ .

Steady-state error for  $15t^2u(t) = \infty$

5.

System is type 0.  $K_p = 1.488$ .

For  $30u(t)$ ,  $e(\infty) = \frac{30}{1+K_p} = 12.1$

For  $70tu(t)$ ,  $e(\infty) = \infty$

For  $81t^2u(t)$ ,  $e(\infty) = \infty$

6.

$$E(s) = \frac{R(s)}{1+G(s)} = \frac{150/S^4}{1 + \frac{210(S+4)(S+6)(S+11)(S+13)}{S^3(S+7)(S+14)(S+19)}}$$

Thus,

$$e(\infty) = \lim_{s \rightarrow 0} sE(s) = \frac{150}{\frac{(210)(4)(6)(11)(13)}{(7)(14)(19)}} = 0.3875$$

7.

$$\mathcal{L}\left[\frac{de}{dt}\right] = sE(s)$$

$$\text{Therefore, } \dot{e}(\infty) = \lim_{s \rightarrow 0} s^2 E(s) = \lim_{s \rightarrow 0} s^2 \frac{R(s)}{1+G(s)} = \lim_{s \rightarrow 0} \frac{s^2 \frac{6}{s^4}}{1 + \frac{100(s+1)(s+2)}{s^2(s+10)(s+3)}} = \frac{9}{10}$$

8.

$$e(\infty) = \frac{15}{1 + K_p}; K_p = \frac{1020(13)(26)(33)}{(65)(75)(91)} = 25.65. \text{ Therefore, } e(\infty) = 0.563.$$

9.

$$\text{For } 70u(t), e_{ss} = \frac{70}{1 + K_p} = \frac{70}{5} = 14; \text{ For } 70tu(t), e_{ss} = \infty, \text{ since the system is Type 0.}$$

10.

a. The closed-loop transfer function is,

$$T(s) = \frac{5000}{s^2 + 75s + 5000}$$

from which,  $\omega_n = \sqrt{5000}$  and  $2\zeta\omega_n = 75$ . Thus,  $\zeta = 0.53$  and

$$\%OS = e^{-\zeta\pi / \sqrt{1-\zeta^2}} \times 100 = 14.01\%.$$

$$\text{b. } T_s = \frac{4}{\zeta\omega_n} = \frac{4}{75/2} = 0.107 \text{ second.}$$

c. Since system is Type 1,  $e_{ss}$  for  $5u(t)$  is zero.

$$\text{d. Since } K_v \text{ is } \frac{5000}{75} = 66.67, e_{ss} = \frac{5}{K_v} = 0.075.$$

e.  $e_{ss} = \infty$ , since system is Type 1.

11.

$$K_v = \lim_{s \rightarrow 0} sG(s) = \frac{100500(5)(14)(23)}{(27)(\alpha)(33)} = 25000$$

Thus,  $\alpha = 7.26$ .

12.

$$K_a = \lim_{s \rightarrow 0} s^2 G(s) = \frac{Kx2x4x6}{5x7} = 10,000. \text{ Therefore, } K = 7291.667.$$

13.

$$\text{a. } G_e(s) = \frac{\frac{5}{s(s+1)(s+2)}}{1 + \frac{5(s+3)}{s(s+1)(s+2)}} = \frac{5}{s^3 + 3s^2 + 7s + 15}$$

Therefore,  $K_p = 1/3$ ;  $K_v = 0$ ; and  $K_a = 0$ .



b. For  $50u(t)$ ,  $e(\infty) = \frac{50}{1 + K_p} = 37.5$ ; For  $50tu(t)$ ,  $e(\infty) = \infty$ ; For  $50t^2u(t)$ ,  $e(\infty) = \infty$

c. Type 0

14.

$$E(s) = \frac{R(s)}{1 + G(s)}. \text{ Thus, } e(\infty) = \lim_{s \rightarrow 0} sE(s) = \lim_{s \rightarrow 0} \frac{s \frac{60}{s^4}}{1 + \frac{1030(s^2 + 8s + 23)(s^2 + 21s + 18)}{s^3(s + 6)(s + 13)}}$$

$$= 0.0110.$$

15.

Collapsing the inner loop and multiplying by  $1000/s$  yields the equivalent forward-path transfer function as,

$$G_e(s) = \frac{10^5(s + 2)}{s(s^2 + 1005s + 2000)}$$

Hence, the system is Type 1.

16.

The transfer function from command input to error signal can be found using Mason's rule or any other method:

$$\frac{E(s)}{R(s)} = \frac{1 - \frac{20}{s(s+3)}G_2}{1 + \frac{20}{s(s+3)}G_1} = \frac{s(s+3) - 20G_2}{s(s+3) + 20G_1}$$

Letting  $R(s) = \frac{1}{s}$  and by the final value theorem:

$$e_{ss} = \lim_{s \rightarrow 0} sE(s) = - \lim_{s \rightarrow 0} \frac{G_2(s)}{G_1(s)}$$

a. If  $G_1$  is type 0, it is required that  $G_2(s) = 0$

b. If  $G_1$  is type 1, it is required that  $G_2(s)$  must be type 0

c. If  $G_1$  is type 2, it is required that  $G_2(s)$  must be type 1

17.

$$\dot{e}(\infty) = \lim_{s \rightarrow 0} s^2 E(s) = \lim_{s \rightarrow 0} s^2 \frac{R(s)}{1 + G(s)}$$

For Type 0, step input:  $R(s) = \frac{1}{s}$ , and  $\dot{e}(\infty) = \lim_{s \rightarrow 0} \frac{s}{1 + G(s)} = 0$

For Type 0, ramp input:  $R(s) = \frac{1}{s^2}$ , and

$$\dot{e}(\infty) = \lim_{s \rightarrow 0} \frac{1}{1 + G(s)} = \frac{1}{1 + \lim_{s \rightarrow 0} G(s)} = \frac{1}{1 + K_p}$$

For Type 0, parabolic input:  $R(s) = \frac{1}{s^3}$ , and  $\dot{e}(\infty) = \lim_{s \rightarrow 0} \frac{1}{s + sG(s)} = \infty$

For Type 1, step input:  $R(s) = \frac{1}{s}$ , and  $\dot{e}(\infty) = \lim_{s \rightarrow 0} \frac{s}{1 + G(s)} = 0$

For Type 1, ramp input:  $R(s) = \frac{1}{s^2}$ , and  $\dot{e}(\infty) = \lim_{s \rightarrow 0} \frac{1}{1 + G(s)} = 0$

For Type 1, parabolic input:  $R(s) = \frac{1}{s^3}$ , and  $\dot{e}(\infty) = \lim_{s \rightarrow 0} \frac{1}{s + sG(s)} = \frac{1}{K_v}$

For Type 2, step input:  $R(s) = \frac{1}{s}$ , and  $\dot{e}(\infty) = \lim_{s \rightarrow 0} \frac{s}{1 + G(s)} = 0$

For Type 2, ramp input:  $R(s) = \frac{1}{s^2}$ , and  $\dot{e}(\infty) = \lim_{s \rightarrow 0} \frac{1}{1 + G(s)} = 0$

For Type 2, parabolic input:  $R(s) = \frac{1}{s^3}$ , and  $\dot{e}(\infty) = \lim_{s \rightarrow 0} \frac{1}{s + sG(s)} = 0$

		TYPE		
		0	1	2
INPUT	Step	0	0	0
	Ramp	$\frac{1}{1 + K_p}$	0	0
	Parabola	$\infty$	$\frac{1}{K_v}$	0

18.

a.  $e(\infty) = \frac{1/10}{K_v} = 0.01$ ; where  $K_v = \frac{7K}{5 \times 8 \times 12} = 10$ . Thus,  $K = 685.71$ .

b.  $K_v = 10$ .

c. The minimum error will occur for the maximum gain before instability. Using the Routh-Hurwitz

Criterion along with  $T(s) = \frac{K(s+7)}{s^4 + 25s^3 + 196s^2 + (480 + K)s + 7K}$ :

$s^4$	1	196	$7K$	For Stability
$s^3$	25	$480+K$		
$s^2$	$4420-K$	$175K$		$K < 4420$
$s^1$	$-K^2 - 435K + 2121600$			$-1690.2 < K < 1255.2$
$s^0$	$175K$			$K > 0$

Thus, for stability and minimum error  $K = 1255.2$ . Thus,  $K_v = \frac{7K}{5 \times 8 \times 12} = 18.3$  and

$$e(\infty) = \frac{1/10}{K_v} = \frac{1/10}{18.3} = 0.0055.$$

19.

$$e(\infty) = \frac{40}{K_v} = \frac{40}{Ka/26} = \frac{1040}{Ka} = 0.006. \text{ Hence, } Ka = 173333.33.$$

20.

Find the equivalent  $G(s)$  for a unity feedback system.  $G(s) = \frac{K}{s(s+1)} = \frac{K}{s(s+11)}$ . Thus,  $e(\infty) =$

$$\frac{100}{K_v} = \frac{100}{K/11} = 0.01; \text{ from which } K = 110,000.$$

21.

$$K_a = \frac{3K}{7}; e(\infty) = \frac{20}{K_a} = 0.061. \text{ Hence, } K = 765.03.$$

22.

a.  $e(\infty) = \frac{10}{K_v} = \frac{1}{6000}$ . But,  $K_v = \frac{30K}{5} = 60,000$ . Hence,  $K = 10,000$ . For finite error for a ramp

input,  $n = 1$ .

$$\text{b. } K_p = \lim_{s \rightarrow 0} G(s) = \lim_{s \rightarrow 0} \frac{10000(s^2 + 3s + 30)}{s(s+5)} = \infty$$

$$K_v = \lim_{s \rightarrow 0} sG(s) = \lim_{s \rightarrow 0} s \frac{10000(s^2 + 3s + 30)}{s(s+5)} = 60000$$

$$K_a = \lim_{s \rightarrow 0} s^2 G(s) = \lim_{s \rightarrow 0} s^2 \frac{10000(s^2 + 3s + 30)}{s(s+5)} = 0$$

23.

a. Type 0

$$\text{b. } E(s) = \frac{R(s)}{1+G(s)}. \text{ Thus, } e(\infty) = \lim_{s \rightarrow 0} sE(s) = \lim_{s \rightarrow 0} s \frac{12/s}{1 + \frac{K(s^2 + 6s + 6)}{(s+5)^2(s+3)}} = \frac{12}{1+0.08K}.$$

c.  $e(\infty) = \infty$ , since the system is Type 0.

24.

$$e(\infty) = \frac{27}{K_v} = \frac{27}{247K/1188} = 0.4. \text{ Thus, } K = 325.$$

25.

$$e(\infty) = \frac{1}{1+K_p} = \frac{1}{1+\frac{6K}{58}} = 0.08. \text{ Thus, } K = 111.$$

26.

The system is stable for  $0 < K < 2000$ . Since the maximum  $K_v$  is  $K_v = \frac{K}{320} = \frac{2000}{320} = 6.25$ , the minimum steady-state error is  $\frac{1}{K_v} = \frac{1}{6.25} = 0.16$ .

27.

To meet steady-state error characteristics:

$$E(s) = \frac{R(s)}{1+G(s)} = \frac{1}{s \left( 1 + \frac{K(s+\alpha)}{(s+\beta)^2} \right)}$$

$$e(t) \Big|_{t \rightarrow \infty} = sE(s) \Big|_{s \rightarrow 0} = \frac{1}{1 + \frac{K\alpha}{\beta^2}} = \frac{\beta^2}{\beta^2 + K\alpha} = 0.1$$

Therefore,  $K\alpha = 9\beta^2$ .To meet the transient requirement: Since  $T(s) = \frac{K(s+\alpha)}{s^2 + (K+2\beta)s + (\beta^2 + K\alpha)}$ ,
 $\omega_n^2 = 10 = \beta^2 + K\alpha$ ;  $2\zeta\omega_n = \sqrt{10} = K+2\beta$ . Solving for  $\beta$ ,  $\beta = \pm 1$ . For  $\beta = +1$ ,  $K = 1.16$  and  $\alpha = 7.76$ .
An alternate solution is  $\beta = -1$ ,  $K = 5.16$ , and  $\alpha = 1.74$ .

28.

a. System Type = 1

b. Assume  $G(s) = \frac{K}{s(s+\alpha)}$ . Therefore,  $e(\infty) = \frac{1}{K_v} = \frac{1}{K/\alpha} = 0.01$ , or  $\frac{K}{\alpha} = 100$ .

$$\text{But, } T(s) = \frac{G(s)}{1+G(s)} = \frac{K}{s^2 + \alpha s + K}.$$

Since  $\omega_n = 10$ ,  $K = 100$ , and  $\alpha = 1$ . Hence,  $G(s) = \frac{100}{s(s+1)}$ .

c.  $2\zeta\omega_n = \alpha = 1$ . Thus,  $\zeta = \frac{1}{20}$ .

29.

$$T(s) = \frac{G(s)}{1+G(s)} = \frac{K(s+\alpha)}{s^2+(K+\beta)s+\alpha K}. \text{ Hence, } K+\beta = 2, K\alpha = \omega_n^2 = (1^2+1^2) = 2.$$

Also,  $e(\infty) = \frac{1}{K_v} = \frac{\beta}{K\alpha} = 0.1$ . Therefore,  $\beta = 0.1K\alpha = 0.2$ ,  $K = 1.8$ , and  $\alpha = 1.111$ .

30.

System Type = 1.  $T(s) = \frac{G(s)}{1+G(s)} = \frac{K}{s^2+as+K}$ . From  $G(s)$ ,  $K_v = \frac{K}{a} = 110$ . For 12% overshoot,  $\zeta =$

0.56. Therefore,  $2\zeta\omega_n = a$ , and  $\omega_n^2 = K$ . Hence,  $a = 1.12\sqrt{K}$ .

Also,  $a = \frac{K}{110}$ . Solving simultaneously,

$K = 1.52 \times 10^4$ , and  $a = 1.38 \times 10^2$ .

31.

a. For 20% overshoot,  $\zeta = 0.456$ . Also,  $K_v = 1000 = \frac{K}{a}$ . Since  $T(s) = \frac{K}{s^2+as+K}$ ,  $2\zeta\omega_n = a$ , and

$\omega_n = \sqrt{K}$ . Hence,  $a = 0.912\sqrt{K}$ . Solving for  $a$  and  $K$ ,  $K = 831,744$ , and  $a = 831.744$ .

b. For 10% overshoot,  $\zeta = 0.591$ . Also,  $\frac{1}{K_v} = 0.01$ . Thus,  $K_v = 100 = \frac{K}{a}$ . Since  $T(s) = \frac{K}{s^2+as+K}$ ,

$2\zeta\omega_n = a$ , and  $\omega_n = \sqrt{K}$ . Hence,  $a = 1.182\sqrt{K}$ . Solving for  $a$  and  $K$ ,  $K = 13971$  and  $a = 139.71$ .

32.

a. For the inner loop:

$$G_1(s) = \frac{\frac{1}{s^2(s+1)}}{1 + \frac{1}{s^3(s+1)}} = \frac{s}{s^4+s^3+1}$$

$$G_e(s) = \frac{1}{s^2(s+3)} G_1(s) = \frac{1}{s(s^5+4s^4+3s^3+s+3)}$$

$$T(s) = \frac{G_e(s)}{1+G_e(s)} = \frac{1}{s^6+4s^5+3s^4+s^2+3s+1}$$

b. From  $G_e(s)$ , system is Type 1.

c. Since system is Type 1,  $e_{ss} = 0$

d. ; From  $G_e(s)$ ,  $K_v = \lim_{s \rightarrow 0} sG_e(s) = \frac{1}{3}$ . Therefore,  $e_{ss} = \frac{5}{K_v} = 15$ .

e. Poles of  $T(s) = -3.0190, -1.3166, 0.3426 \pm j0.7762, -0.3495$ . Therefore, system is unstable and results of (c) and (d) are meaningless

33.

a. For the inner loop:

$$G_1(s) = \frac{\frac{10}{s(s+1)(s+3)(s+4)}}{1 + \frac{20}{(s+1)(s+3)(s+4)}} = \frac{10}{s(s^3+8s^2+19s+32)}$$

$$G_e(s) = \frac{20}{s(s^3+8s^2+19s+32)}$$

$$T(s) = \frac{G_e(s)}{1+G_e(s)} = \frac{20}{s^4+8s^3+19s^2+32s+20}$$

b. From  $G_e(s)$ , system is Type 1.

c. Since system is Type 1,  $e_{ss} = 0$

d. From  $G_e(s)$ ,  $K_V = \lim_{s \rightarrow 0} sG_e(s) = \frac{20}{32} = \frac{5}{8}$ . Therefore,  $e_{ss} = \frac{5}{K_V} = 8$ .

e. Poles of  $T(s) = -5.4755, -0.7622 \pm j1.7526, -1$ . Therefore, system is stable and results of parts c and d are valid.

34.

**Program:**

```

numg1=[1 9];deng1=poly([0 -6 -12 -14]);
'G1(s)='
G1=tf(numg1,deng1)
numg2=6*poly([-9 -17]);deng2=poly([-12 -32 -68]);
'G2(s)='
G2=tf(numg2,deng2)
numh1=13;denh1=1;
'H1(s)='
H1=tf(numh1,denh1)
numh2=1;denh2=[1 7];
'H2(s)='
H2=tf(numh2,denh2)
%Close loop with H1 and form G3
'G3(s)=G2(s)/(1+G2(s)H1(s) '
G3=feedback(G2,H1)
%Form G4=G1G3
'G4(s)=G1(s)G3(s) '
G4=series(G1,G3)
%Form Ge=G4/1+G4H2
'Ge(s)=G4(s)/(1+G4(s)H2(s)) '
Ge=feedback(G4,H2)
%Form T(s)=Ge(s)/(1+Ge(s)) to test stability
'T(s)=Ge(s)/(1+Ge(s)) '
T=feedback(Ge,1)
'Poles of T(s) '
pole(T)
%Computer response shows that system is stable. Now find error specs.
Kp=dcgain(Ge)
'sGe(s)='
sGe=tf([1 0],1)*Ge;
'sGe(s) '

```

7-12 Chapter 7: Steady-State Errors

```
sGe=minreal(sGe)
Kv=dcgain(sGe)
's^2Ge(s)='
s2Ge=tf([1 0],1)*sGe;
's^2Ge(s)'
s2Ge=minreal(s2Ge)
Ka=dcgain(s2Ge)
essstep=100/(1+Kp)
essramp=100/Kv
essparabola=200/Ka
```

**Computer response:**

```
ans =
G1(s)=
Transfer function:
s + 9
-----
s^4 + 32 s^3 + 324 s^2 + 1008 s
ans =
G2(s)=
Transfer function:
6 s^2 + 156 s + 918
-----
s^3 + 112 s^2 + 3376 s + 26112
ans =
H1(s)=
Transfer function:
13
ans =
H2(s)=
Transfer function:
1
-----
s + 7
ans =
G3(s)=G2(s)/(1+G2(s)H1(s))
Transfer function:
6 s^2 + 156 s + 918
-----
s^3 + 190 s^2 + 5404 s + 38046
Solutions to Problems 7-13
ans =
G4(s)=G1(s)G3(s)
Transfer function:
6 s^3 + 210 s^2 + 2322 s + 8262
-----
s^7 + 222 s^6 + 11808 s^5 + 273542 s^4 + 3.16e006 s^3
+ 1.777e007 s^2 + 3.835e007 s
ans =
Ge(s)=G4(s)/(1+G4(s)H2(s))
Transfer function:
6 s^4 + 252 s^3 + 3792 s^2 + 24516 s + 57834
-----
s^8 + 229 s^7 + 13362 s^6 + 356198 s^5 + 5.075e006 s^4
+ 3.989e007 s^3 + 1.628e008 s^2 + 2.685e008 s
+ 8262
ans =
T(s)=Ge(s)/(1+Ge(s))
Transfer function:
6 s^4 + 252 s^3 + 3792 s^2 + 24516 s + 57834
-----
s^8 + 229 s^7 + 13362 s^6 + 356198 s^5 + 5.075e006 s^4
+ 3.989e007 s^3 + 1.628e008 s^2 + 2.685e008 s
+ 66096
ans =
Poles of T(s)
ans =
-157.1538
-21.6791
```

```

-14.0006
-11.9987
-11.1678
-7.0001
-5.9997
-0.0002
Kp =
7
ans =
sGe(s)=
ans =
sGe(s)
Transfer function:
6 s^5 + 252 s^4 + 3792 s^3 + 2.452e004 s^2
+ 5.783e004 s
-----
s^8 + 229 s^7 + 1.336e004 s^6 + 3.562e005 s^5
+ 5.075e006 s^4 + 3.989e007 s^3 + 1.628e008 s^2
+ 2.685e008 s + 8262
Kv =
0
ans =
s^2Ge(s)=
ans =
s^2Ge(s)
Transfer function:
6 s^6 + 252 s^5 + 3792 s^4 + 2.452e004 s^3
+ 5.783e004 s^2
-----
s^8 + 229 s^7 + 1.336e004 s^6 + 3.562e005 s^5
+ 5.075e006 s^4 + 3.989e007 s^3 + 1.628e008 s^2
+ 2.685e008 s + 8262

```

**Solutions to Problems 7-15**

```

Ka =
0
essstep =
12.5000
essramp =
Inf
essparabola =
Inf

```

**35.**

The equivalent forward transfer function is,  $G(s) = \frac{10K_1}{s(s+1+10K_f)}$ .

Also,  $T(s) = \frac{G(s)}{1+G(s)} = \frac{10K_1}{s^2+(10K_f+1)s+10K_1}$ . From the problem statement,  $K_v = \frac{10K_1}{1+10K_f} = 10$ .

Also,  $2\zeta\omega_n = 10K_f+1 = 2(0.5)\sqrt{10K_1} = \sqrt{10K_1}$ . Solving for  $K_1$  and  $K_f$  simultaneously,  $K_1 = 10$  and

$K_f = 0.9$ .

**36.**

We calculate the Velocity Error Constant,



$$K_v = \lim_{s \rightarrow 0} sG(s)P(s) = \lim_{s \rightarrow 0} \frac{s(-34.16s^3 - 144.4s^2 + 7047s + 557.2)}{s^5 + 13.18s^4 + 95.93s^3 + 14.61s^2 + 31.94s} \frac{0.00842(s + 7.895)(s^2 + 0.108s + 0.3393)}{(s + 0.07895)(s^2 + 4s + 8)}$$

$$= \frac{557.2}{31.94} 0.0357 = 0.623$$

For a unit ramp input the steady state error is  $e_{ss} = \frac{1}{K_v} = 1.605$ . The input slope is  $\frac{25}{1.605} = 15.6$

37.

a.

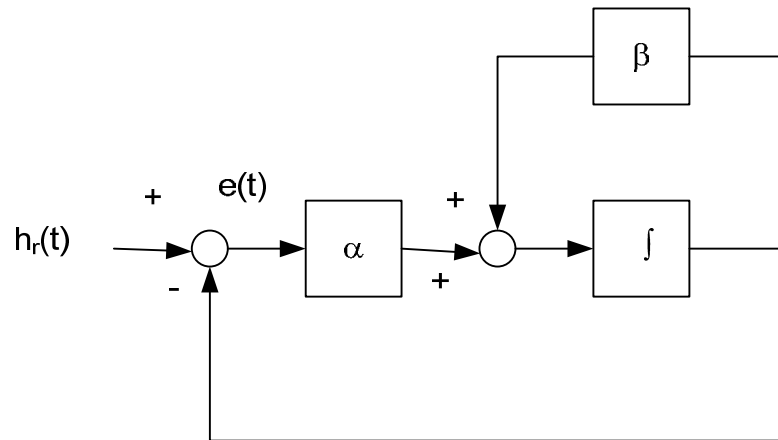

From the point of view of  $e(t)$  the above block diagram is equivalent to the original. In this unity

feedback block diagram the open loop transmission is  $G(s) = \alpha \frac{\frac{1}{s}}{1 + \frac{\beta}{s}} = \frac{\alpha}{s + \beta}$ , the system is

type 0.

b. The position error constant is  $K_p = G(0) = \frac{\alpha}{\beta}$ . The steady state error is

$$e_{ss} = \frac{1}{1 + K_p} = \frac{1}{1 + \frac{\alpha}{\beta}} = \frac{\beta}{\alpha + \beta}$$

38.

$e(\infty) = \lim_{s \rightarrow 0} \frac{sR(s) - sD(s)G_2(s)}{1 + G_1(s)G_2(s)}$ , where  $G_1(s) = \frac{1}{s+5}$  and  $G_2 = \frac{100}{s+2}$ . From the problem statement,

$$R(s) = D(s) = \frac{1}{s}. \text{ Hence, } e(\infty) = \lim_{s \rightarrow 0} \frac{1 - \frac{100}{s+2}}{1 + \frac{1}{s+5} \frac{100}{s+2}} = -\frac{49}{11}.$$

39.

Error due only to disturbance: Rearranging the block diagram to show  $D(s)$  as the input,

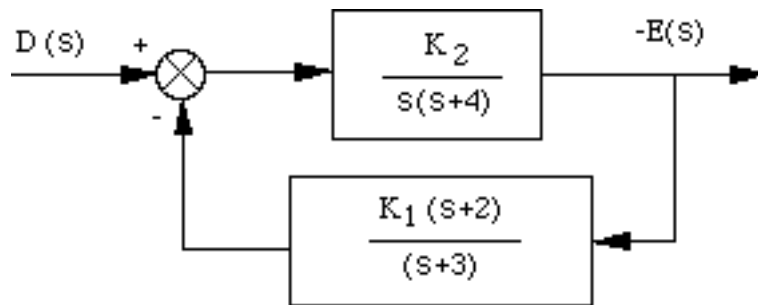

Therefore,

$$-E(s) = D(s) \frac{\frac{K_2}{s(s+4)}}{1 + \frac{K_1 K_2 (s+2)}{s(s+3)(s+4)}} = D(s) \frac{K_2 (s+3)}{s(s+3)(s+4) + K_1 K_2 (s+2)}$$

$$\text{For } D(s) = \frac{1}{s}, e_D(\infty) = \lim_{s \rightarrow 0} sE(s) = -\frac{3}{2K_1}.$$

$$\text{Error due only to input: } e_R(\infty) = \frac{1}{K_V} = \frac{1}{K_1 K_2} = \frac{6}{K_1 K_2}.$$

Design:

$$e_D(\infty) = -0.000012 = -\frac{3}{2K_1}, \text{ or } K_1 = 125,000.$$

$$e_R(\infty) = 0.003 = \frac{6}{K_1 K_2}, \text{ or } K_2 = 0.016$$



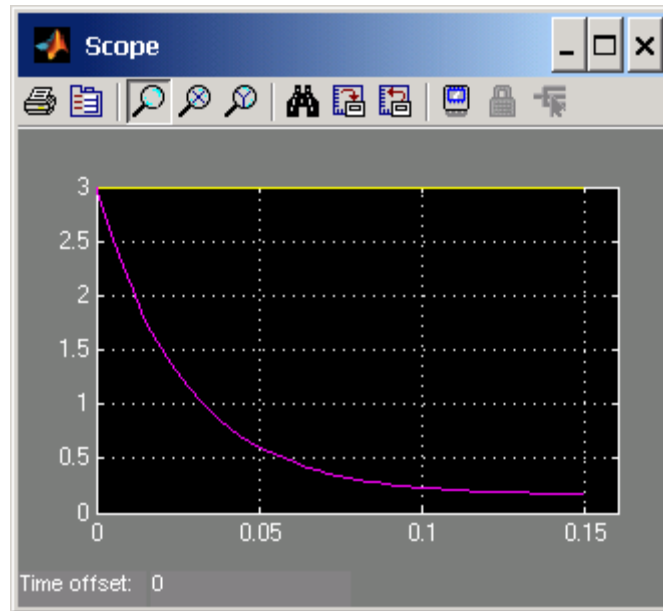

c. The transfer function from disturbance to error signal is 
$$\frac{E(s)}{D(s)} = -\frac{\frac{7}{s+2}}{1+5\frac{7}{s+2}} = -\frac{7}{s+37}$$

Using the final value theorem  $e_{ssd} = \lim_{s \rightarrow 0} sE(s) = \lim_{s \rightarrow 0} s \left( -\frac{7}{s+37} \right) \left( -\frac{1}{s} \right) = \frac{7}{37} = 0.1892$

d.

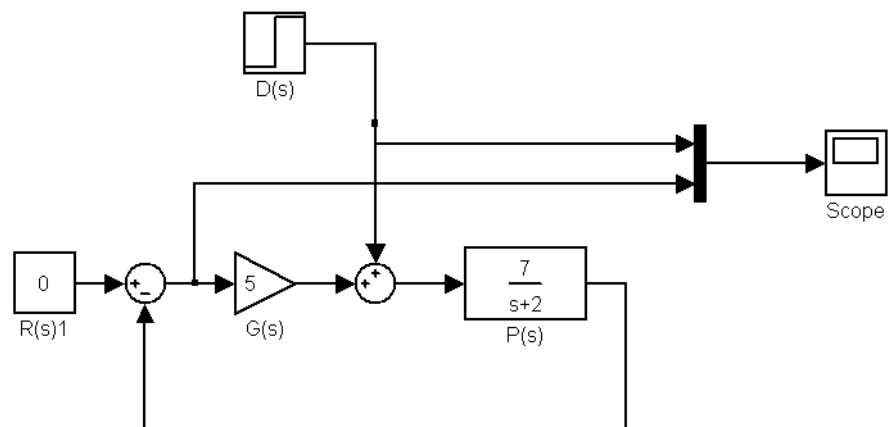

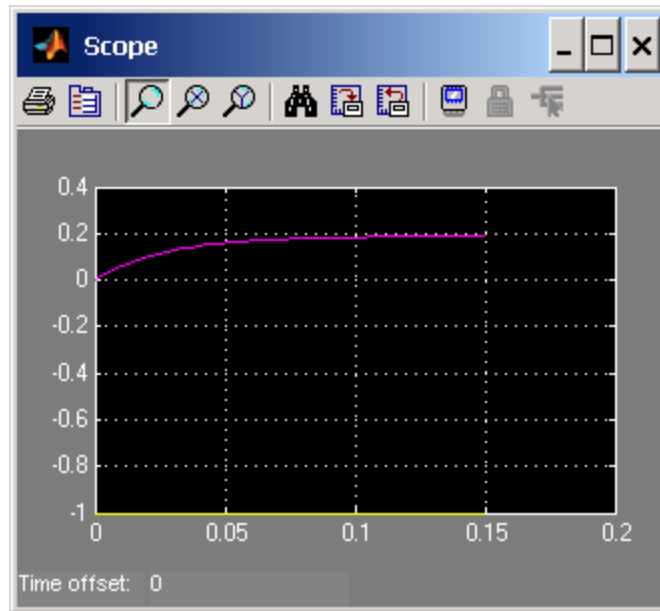

e.  $e_{tot} = e_{ssr} + e_{ssd} = 0.1622 + 0.1892 = 0.351$

f.

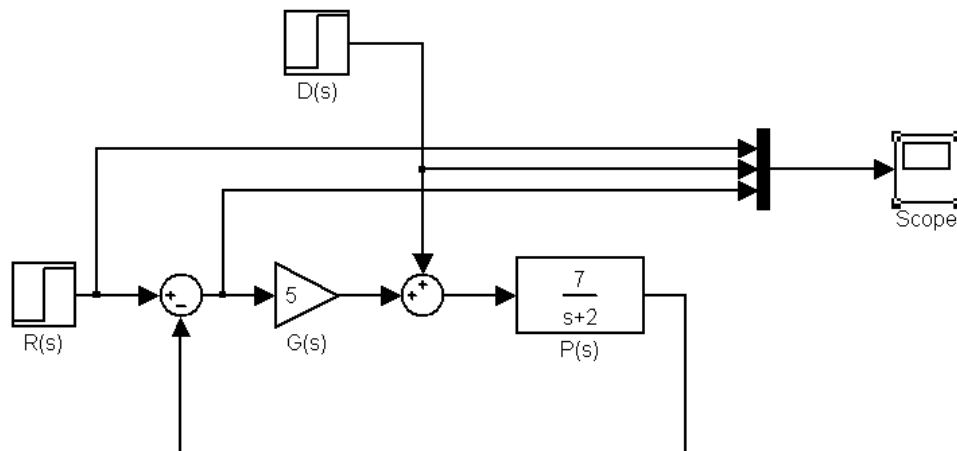

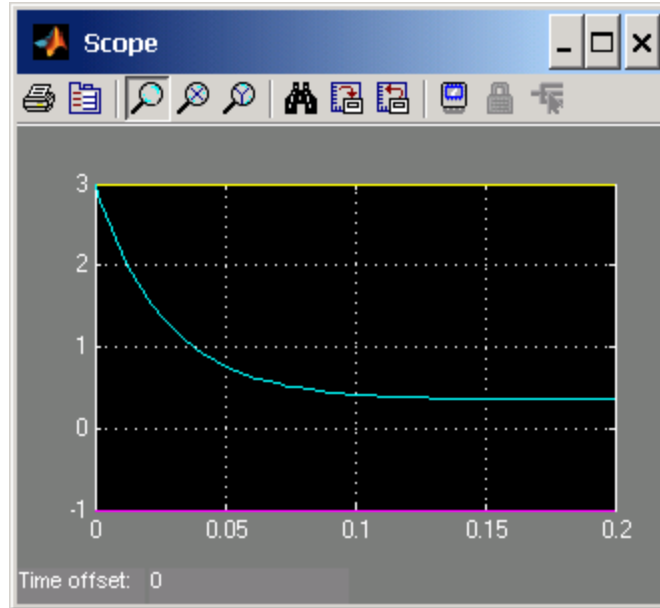

41.

$$\frac{C(s)}{R(s)} = \frac{G_1(s)G_2(s)}{1 + G_2(s)H_1(s)}; \quad \therefore \frac{E_{a1}(s)}{R(s)} = \frac{G_1(s)}{1 + G_2(s)H_1(s)}$$

$$e_{a1}(\infty) = \lim_{s \rightarrow 0} \frac{sR(s)G_1(s)}{1 + G_2(s)H_1(s)}$$

42.

**System 1:**

Forming a unity-feedback path, the equivalent unity feedback system has a forward transfer function of

$$G_e(s) = \frac{\frac{10(s+10)}{s(s+2)}}{1 + \frac{10(s+10)(s+3)}{s(s+2)}} = \frac{10(s+10)}{11s^2 + 132s + 300}$$

a. Type 0 System; b.  $K_p = K_p = \lim_{s \rightarrow 0} G_e(s) = 1/3$ ; c. step input; d.  $e(\infty) = \frac{1}{1 + K_p} = 3/4$ ;

$$\text{e. } e_{a\text{-step}}(\infty) = \lim_{s \rightarrow 0} \frac{sR(s)}{1 + G(s)H(s)} = \lim_{s \rightarrow 0} \frac{s \left( \frac{1}{s} \right)}{1 + \frac{10(s+10)(s+4)}{s(s+2)}} = 0.$$

**System 2:**

Forming a unity-feedback path, the equivalent unity feedback system has a forward transfer function of

$$G_e(s) = \frac{\frac{10(s+10)}{s(s+2)}}{1 + \frac{10(s+10)s}{s(s+2)}} = \frac{10(s+10)}{s(11s+102)}$$

a. Type 1 System; b.  $K_v = \lim_{s \rightarrow 0} sG_e(s) = 0.98$ ; c. ramp input; d.  $e(\infty) = \frac{1}{K_v} = 1.02$ ;

e.  $e_{a-ramp}(\infty) = \lim_{s \rightarrow 0} \frac{sR(s)}{1 + G(s)H(s)} = \lim_{s \rightarrow 0} \frac{s\left(\frac{1}{s^2}\right)}{1 + \frac{10(s+10)(s+1)}{s(s+2)}} = \frac{1}{50}$ .

43. **System 1.** Push 5 to the right past the summing junction:

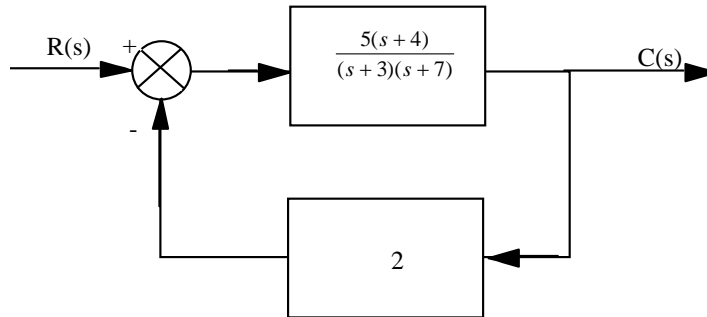

Produce a unity-feedback system:

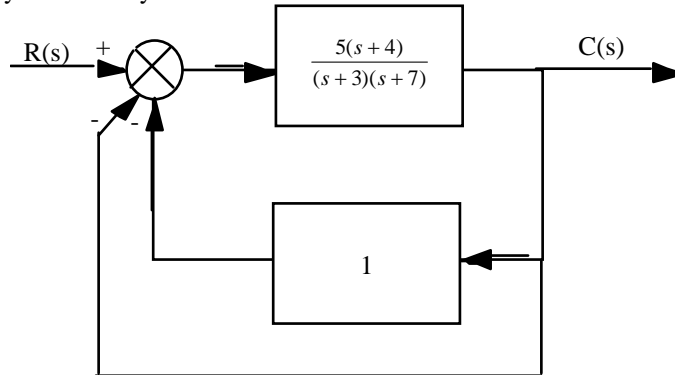

Thus,  $G_e(s) = \frac{\frac{5(s+4)}{(s+3)(s+7)}}{1 + \frac{5(s+4)}{(s+3)(s+7)}} = \frac{5(s+4)}{s^2 + 15s + 41}$ .  $K_p = \frac{20}{41}$ .  $e_{step} = \frac{1}{1+K_p} = 0.67$ ,  $e_{ramp} = \infty$ ,

$e_{parabola} = \infty$ .

Checking for stability, from first block diagram above,  $T(s) = \frac{5(s+4)}{s^2 + 20s + 61}$ . The system is stable.

**System 2.** Push 20 to the right past the summing junction and push 10 to the left past the pickoff point:

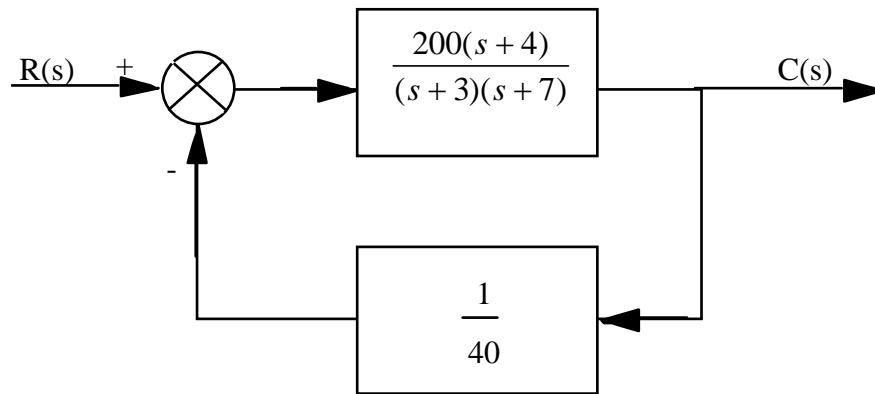

Produce a unity-feedback system:

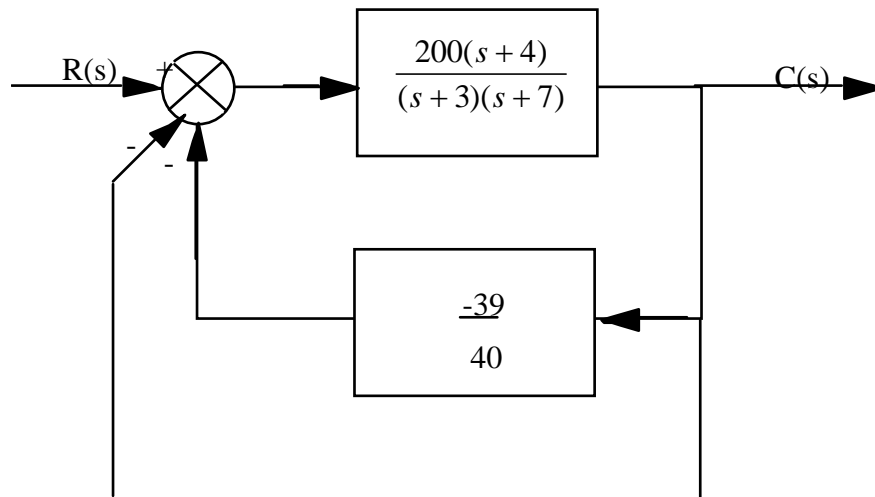

$$\text{Thus, } G_e(s) = \frac{\frac{200(s+4)}{(s+3)(s+7)}}{1 - \frac{200(s+4)}{(s+3)(s+7)} \left( \frac{39}{40} \right)} = \frac{200(s+4)}{s^2 - 185s - 759} \cdot K_p = \frac{200(4)}{-759} = -1.05.$$

$$e_{\text{step}} = \frac{1}{1+K_p} = -20, \quad e_{\text{ramp}} = \infty, \quad e_{\text{parabola}} = \infty.$$

$$\text{Checking for stability, from first block diagram above, } T(s) = \frac{G_e(s)}{1+G_e(s)} = \frac{200(s+4)}{s^2 + 15s + 41}.$$

Therefore, system is stable and steady-state error calculations are valid.

44.

a. Produce a unity-feedback system:



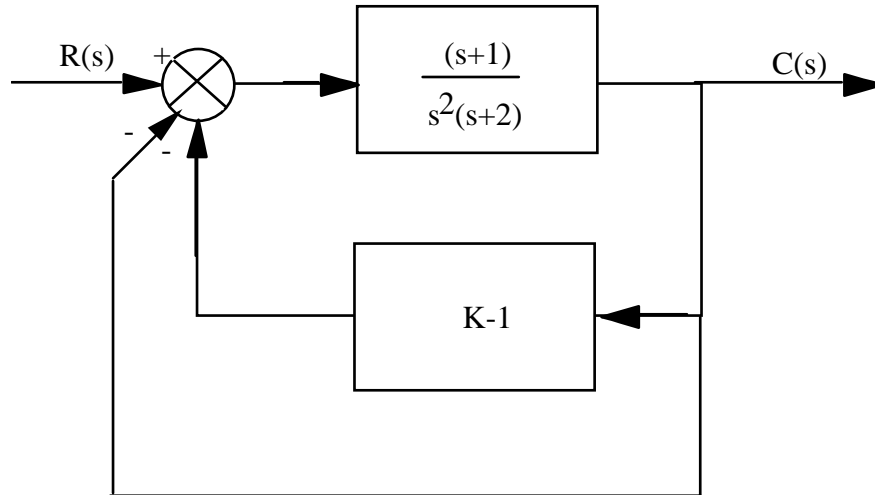

Thus,  $G_e(s) = \frac{\frac{(s+1)}{s^2(s+2)}}{1 + \frac{(s+1)(K-1)}{s^2(s+2)}} = \frac{s+1}{s^3+2s^2+(K-1)s+(K-1)}$ . System is Type 0.

b. Since the system is Type 0, the appropriate static error constant is  $K_p$ . Thus,

$$e_{step}(\infty) = 0.001 = \frac{1}{1 + K_p}$$

Therefore,  $K_p = 999 = \frac{1}{K-1}$ . Hence,  $K = 1.001001$ .

Check stability: Using original block diagram,  $T(s) = \frac{\frac{(s+1)}{s^2(s+2)}}{1 + \frac{K(s+1)}{s^2(s+2)}} = \frac{s+1}{s^3+2s^2+Ks+K}$ .

Making a Routh table:

$s^3$	1	K
$s^2$	2	K
$s^1$	$\frac{K}{2}$	0
$s^0$	K	0

Therefore, system is stable and steady-state error calculations are valid.

45.

a. Produce a unity-feedback system:

$$H_1(s) = \frac{s+4}{s+2} - 1 = \frac{2}{s+2}$$

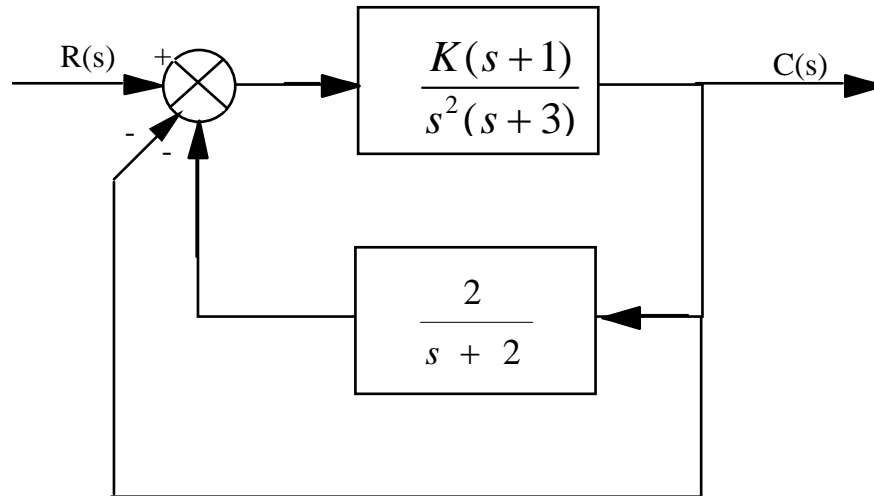

$$\text{Thus, } G_e(s) = \frac{\frac{K(s+1)}{s^2(s+3)}}{1 + \frac{2K(s+1)}{s^2(s+3)(s+2)}} = \frac{K(s+1)(s+2)}{s^4 + 5s^3 + 6s^2 + 2Ks + 2K}. \text{ System is Type 0.}$$

b. Since Type 0, appropriate static error constant is  $K_p$ .

$$\text{c. } K_p = \frac{2K}{2K} = 1$$

$$\text{d. } e_{\text{step}} = \frac{1}{1+K_p} = \frac{1}{2}$$

Check stability: Using original block diagram,

$$T(s) = \frac{\frac{K(s+1)}{s^2(s+3)}}{1 + \frac{K(s+1)(s+4)}{s^2(s+3)(s+2)}} = \frac{K(s+1)(s+2)}{s^4 + 5s^3 + (K+6)s^2 + 5Ks + 4K}.$$

Making a Routh table:

$s^4$	1	$K+6$	$4K$
$s^3$	5	$5K$	0
$s^2$	6	$4K$	0
$s^1$	$\frac{5}{3}K$	0	0

$s^0$	4K	0	0
-------	----	---	---

Therefore, system is stable for  $0 < K$  and steady-state error calculations are valid.

46.

**Program:**

```

K=10
numg1=K*poly([-1 -2]);deng1=poly([0 0 -4 -5 -6]);
'G1(s)='
G1=tf(numg1,deng1)
numh1=[1 6];denh1=poly([-8 -9]);
'H1(s)='
H1=tf(numh1,denh1)
'H2(s)=H1-1'
H2=H1-1
%Form Ge(s)=G1(s)/(1+G1(s)H2(s))
'Ge(s)=G1(s)/(1+G1(s)H2(s))'
Ge=feedback(G1,H2)
%Test system stability
'T(s)=Ge(s)/(1+Ge(s))'
T=feedback(Ge,1)
pole(T)
Kp=dcgain(Ge)
'sGe(s)'
sGe=tf([1 0],1)*Ge;
sGe=minreal(sGe)
Kv=dcgain(sGe)
's^2Ge(s)'
s2Ge=tf([1 0],1)*sGe;
s2Ge=minreal(s2Ge)
Ka=dcgain(s2Ge)
essstep=30/(1+Kp)
essramp=30/Kv
essparabola=60/Ka

K=1E6
numg1=K*poly([-1 -2]);deng1=poly([0 0 -4 -5 -6]);
'G1(s)='
G1=tf(numg1,deng1)
numh1=[1 6];denh1=poly([-8 -9]);
'H1(s)='
H1=tf(numh1,denh1)
'H2(s)=H1-1'
H2=H1-1
%Form Ge(s)=G1(s)/(1+G1(s)H2(s))
'Ge(s)=G1(s)/(1+G1(s)H2(s))'
Ge=feedback(G1,H2)
%Test system stability
'T(s)=Ge(s)/(1+Ge(s))'
T=feedback(Ge,1)
pole(T)
Kp=dcgain(Ge)
'sGe(s)'
sGe=tf([1 0],1)*Ge;
sGe=minreal(sGe)

```

```

Kv=dcgain(sGe)
's^2Ge(s)'
s2Ge=tf([1 0],1)*sGe;
s2Ge=minreal(s2Ge)
Ka=dcgain(s2Ge)
essstep=30/(1+Kp)
essramp=30/Kv
essparabola=60/Ka

```

**Computer response:**

K =

10

ans =

G1(s)=

Transfer function:

$$\frac{10 s^2 + 30 s + 20}{s^5 + 15 s^4 + 74 s^3 + 120 s^2}$$

ans =

H1(s)=

Transfer function:

$$\frac{s + 6}{s^2 + 17 s + 72}$$

ans =

H2(s)=H1-1

Transfer function:

$$\frac{-s^2 - 16 s - 66}{s^2 + 17 s + 72}$$

ans =

Ge(s)=G1(s)/(1+G1(s)H2(s))

Transfer function:

$$\frac{10 s^4 + 200 s^3 + 1250 s^2 + 2500 s + 1440}{s^7 + 32 s^6 + 401 s^5 + 2448 s^4 + 7178 s^3 + 7480 s^2 - 2300 s - 1320}$$

## 7-26 Chapter 7: Steady-State Errors

ans =

$$T(s) = Ge(s) / (1 + Ge(s))$$

Transfer function:

$$\frac{10 s^4 + 200 s^3 + 1250 s^2 + 2500 s + 1440}{s^7 + 32 s^6 + 401 s^5 + 2458 s^4 + 7378 s^3 + 8730 s^2 + 200 s + 120}$$

ans =

$$\begin{aligned} & -8.5901 + 0.3993i \\ & -8.5901 - 0.3993i \\ & -6.0000 \\ & -4.4042 + 0.1165i \\ & -4.4042 - 0.1165i \\ & -0.0057 + 0.1179i \\ & -0.0057 - 0.1179i \end{aligned}$$

Kp =

$$-1.0909$$

ans =

$$sGe(s)$$

Transfer function:

$$\frac{10 s^5 + 200 s^4 + 1250 s^3 + 2500 s^2 + 1440 s}{s^7 + 32 s^6 + 401 s^5 + 2448 s^4 + 7178 s^3 + 7480 s^2 - 2300 s - 1320}$$

Kv =

$$0$$

ans =

$$s^2Ge(s)$$

Transfer function:

$$\frac{10 s^6 + 200 s^5 + 1250 s^4 + 2500 s^3 + 1440 s^2}{s^7 + 32 s^6 + 401 s^5 + 2448 s^4 + 7178 s^3 + 7480 s^2 - 2300 s - 1320}$$

Ka =

$$0$$

essstep =

$$-330.0000$$

essramp =

Inf

essparabola =

Inf

K =

1000000

ans =

G1(s)=

Transfer function:

$$\frac{1e006 s^2 + 3e006 s + 2e006}{s^5 + 15 s^4 + 74 s^3 + 120 s^2}$$

ans =

H1(s)=

Transfer function:

$$\frac{s + 6}{s^2 + 17 s + 72}$$

ans =

H2(s)=H1-1

Transfer function:

$$\frac{-s^2 - 16 s - 66}{s^2 + 17 s + 72}$$

ans =

Ge(s)=G1(s)/(1+G1(s)H2(s))

Transfer function:

$$\frac{1e006 s^4 + 2e007 s^3 + 1.25e008 s^2 + 2.5e008 s + 1.44e008}{s^7 + 32 s^6 + 401 s^5 - 997542 s^4 - 1.899e007 s^3 - 1.16e008 s^2 - 2.3e008 s - 1.32e008}$$

7-28 Chapter 7: Steady-State Errors

ans =

$$T(s) = G_e(s) / (1 + G_e(s))$$

Transfer function:

$$\frac{1e006 s^4 + 2e007 s^3 + 1.25e008 s^2 + 2.5e008 s + 1.44e008}{s^7 + 32 s^6 + 401 s^5 + 2458 s^4 + 1.007e006 s^3 + 9.009e006 s^2 + 2e007 s + 1.2e007}$$

ans =

```
-28.2460 +22.2384i
-28.2460 -22.2384i
 16.7458 +22.2084i
 16.7458 -22.2084i
 -6.0000
 -1.9990
 -1.0007
```

Kp =

-1.0909

ans =

$$sG_e(s)$$

Transfer function:

$$\frac{1e006 s^5 + 2e007 s^4 + 1.25e008 s^3 + 2.5e008 s^2 + 1.44e008 s}{s^7 + 32 s^6 + 401 s^5 - 9.975e005 s^4 - 1.899e007 s^3 - 1.16e008 s^2 - 2.3e008 s - 1.32e008}$$

Kv =

0

ans =

$$s^2G_e(s)$$

Transfer function:

$$\frac{1e006 s^6 + 2e007 s^5 + 1.25e008 s^4 + 2.5e008 s^3 + 1.44e008 s^2}{s^7 + 32 s^6 + 401 s^5 - 9.975e005 s^4 - 1.899e007 s^3 - 1.16e008 s^2}$$

$$- 2.3e008 \text{ s} - 1.32e008$$

Ka =

0

essstep =

-330.0000

essramp =

Inf

essparabola =

Inf

47.

a. Mason's rule can be used to find the open loop transfer from input to output:

$$\text{Only one forward path, } T_1 = K_T \left( K_v + \frac{1}{\tau s} \right) K_m \frac{1}{LCs^2}$$

$$\text{Three touching loops, } L_1 = -\frac{K_m \alpha}{Ls}, L_2 = -\frac{1}{LCs^2}, L_3 = -\frac{1}{Z_L Cs}$$

$$\Delta = 1 + \frac{K_m \alpha}{Ls} + \frac{1}{LCs^2} + \frac{1}{Z_L Cs}; \Delta_1 = 1$$

$$G(s) = \frac{T_1 \Delta_1}{\Delta} = \frac{\frac{K_T K_m (K_v + \frac{1}{\tau s})}{LCs^2}}{1 + \frac{K_m \alpha}{Ls} + \frac{1}{LCs^2} + \frac{1}{Z_L Cs}}. \text{ Letting } Z_L = \frac{1}{sC_L}$$

$$G(s) = \frac{\frac{K_T K_m (K_v + \frac{1}{\tau s})}{LCs^2}}{1 + \frac{K_m \alpha}{Ls} + \frac{1}{LCs^2} + \frac{C_L}{C}} = \frac{K_T K_m (K_v \tau s + 1)}{\tau s^2 [L(C + C_L)s + K_m \alpha C]}$$

Since the system is not unity feedback, we calculate

$$\begin{aligned} \frac{G(s)}{1 + GH(s) - G(s)} &= \frac{\frac{K_T K_m (K_v \tau s + 1)}{\tau s^2 [L(C + C_L)s + K_m \alpha C]}}{1 + \beta \frac{K_T K_m (K_v \tau s + 1)}{\tau s^2 [L(C + C_L)s + K_m \alpha C]} - \frac{K_T K_m (K_v \tau s + 1)}{\tau s^2 [L(C + C_L)s + K_m \alpha C]}} \\ &= \frac{K_T K_m (K_v \tau s + 1)}{\tau s^2 [L(C + C_L)s + K_m \alpha C] + (\beta - 1) \frac{K_T K_m (K_v \tau s + 1)}{\tau}} \end{aligned}$$



The system is type 0.

b. For a step input we calculate  $K_p = \lim_{s \rightarrow 0} \frac{G(s)}{1 + GH(s) - G(s)} = \frac{1}{\beta - 1}$

Then  $e_{ss} = \frac{1}{1 + K_p} = 1 - \frac{1}{\beta}$

48.

$$Y(s) = R(s) \frac{G_1(s)G_2(s)}{1 + G_1(s)G_2(s)H(s)} + \frac{D(s)G_2(s)}{1 + G_1(s)G_2(s)H(s)}$$

$$E(s) = R(s) - Y(s) = R(s) - \frac{G_1(s)G_2(s)}{1 + G_1(s)G_2(s)H(s)} R(s) - \frac{D(s)G_2(s)}{1 + G_1(s)G_2(s)H(s)}$$

$$= \left[ 1 - \frac{G_1(s)G_2(s)}{1 + G_1(s)G_2(s)H(s)} \right] R(s) - \frac{G_2(s)}{1 + G_1(s)G_2(s)H(s)} D(s)$$

Thus,

$$e(\infty) = \lim_{s \rightarrow 0} sE(s) = \lim_{s \rightarrow 0} \left\{ \left[ 1 - \frac{G_1(s)G_2(s)}{1 + G_1(s)G_2(s)H(s)} \right] R(s) - \frac{G_2(s)}{1 + G_1(s)G_2(s)H(s)} D(s) \right\}$$

49.

a.  $E(s) = R(s) - C(s)$ . But,  $C(s) = [R(s) - C(s)H(s)]G_1(s)G_2(s) + D(s)$ . Solving for  $C(s)$ ,

$$C(s) = \frac{R(s)G_1(s)G_2(s)}{1 + G_1(s)G_2(s)H(s)} + \frac{D(s)}{1 + G_1(s)G_2(s)H(s)}$$

Substituting into  $E(s)$ ,

$$E(s) = \left[ 1 - \frac{G_1(s)G_2(s)}{1 + G_1(s)G_2(s)H(s)} \right] R(s) - \frac{1}{1 + G_1(s)G_2(s)H(s)} D(s)$$

b. For  $R(s) = D(s) = \frac{1}{s}$ ,

$$e(\infty) = \lim_{s \rightarrow 0} sE(s) = 1 - \frac{\lim_{s \rightarrow 0} G_1(s)G_2(s)}{1 + \lim_{s \rightarrow 0} G_1(s)G_2(s)H(s)} - \frac{1}{1 + \lim_{s \rightarrow 0} G_1(s)G_2(s)H(s)}$$

c. Zero error if  $G_1(s)$  and/or  $G_2(s)$  is Type 1. Also,  $H(s)$  is Type 0 with unity dc gain.

50.

First find the forward transfer function of an equivalent unity feedback system.

$$G_e(s) = \frac{\frac{K}{s(s+1)(s+4)}}{1 + \frac{K(s+a-1)}{s(s+1)(s+4)}} = \frac{K}{s^3 + 5s^2 + (K+4)s + K(a-1)}$$

$$\text{Thus, } e(\infty) = e(\infty) = \frac{1}{1+K_p} = \frac{1}{1 + \frac{K}{K(a-1)}} = \frac{a-1}{a}$$

$$\text{Finding the sensitivity of } e(\infty), S_{e:a} = \frac{a}{e} \frac{\partial e}{\partial a} = \frac{a}{\frac{a-1}{a}} \left( \frac{a - (a-1)}{a^2} \right) = \frac{a-1}{a^2}.$$

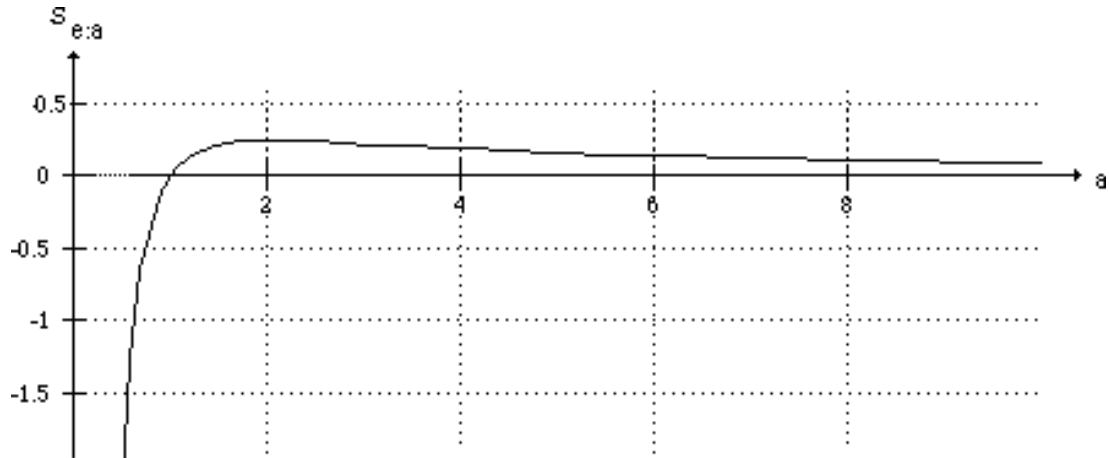

51.

$$\text{a. } S_{T:P} = \frac{P}{T} \frac{\delta T}{\delta P} = \frac{P(s)}{F(s)} \frac{L(s)}{1+L(s)} \frac{(1+L(s))(F(s)G(s)H(s)) - F(s)L(s)(G(s)H(s))}{(1+L(s))^2}$$

$$= \frac{P(s)}{F(s)L(s)} \frac{F(s)G(s)H(s)}{(1+L(s))} = \frac{1}{1+L(s)}$$

$$\text{b. } S_{T:P} + \frac{T(s)}{F(s)} = \frac{1}{1+L(s)} + \frac{L(s)}{1+L(s)} = 1$$

52.

$$\begin{aligned} \text{a. } S_{T:P} &= \frac{P}{T} \frac{\delta T}{\delta P} = \frac{s^2 + 5s}{s^2 + 5s + 14} = \frac{1}{1 + GP(s)} \text{ so } GP(s) = \frac{14}{s(s+5)} \text{ and} \\ G(s) &= \frac{14}{s(s+5)} = \frac{14}{\frac{2}{s}} = \frac{7}{s+5}. \text{ Also } \frac{GP(s)}{1+GP(s)} = \frac{\frac{14}{s(s+5)}}{1 + \frac{14}{s(s+5)}} = \frac{14}{s^2 + 5s + 14}, \text{ so} \\ F(s) &= \frac{T(s)}{1+GP(s)} = \frac{14K}{(s+1)(s+2)(s^2 + 5s + 14)} = \frac{14K}{(s+1)(s+2)} \end{aligned}$$

b. The system is type 1, so for  $e_{ss} = 0$  it is required that  $\lim_{s \rightarrow 0} sF(s) = 7K = 1$ . So  $K = \frac{1}{7}$ .

53.

From Eq. (7.70),

$$e(\infty) = 1 - \lim_{s \rightarrow 0} \left( \frac{\frac{K_1 K_2}{(s+2)}}{1 + \frac{K_1 K_2 (s+1)}{(s+2)}} \right) = \lim_{s \rightarrow 0} \left( \frac{\frac{K_2}{(s+2)}}{1 + \frac{K_1 K_2 (s+1)}{(s+2)}} \right) = \frac{2 - K_2}{2 + K_1 K_2}$$

Sensitivity to  $K_1$ :

$$S_{e:K_1} = \frac{K_1}{e} \frac{\delta e}{\delta K_1} = -\frac{K_1 K_2}{2 + K_1 K_2} = -\frac{(100)(0.1)}{2 + (100)(0.1)} = -0.833$$

Sensitivity to  $K_2$ :

$$S_{e:K_2} = \frac{K_2}{e} \frac{\delta e}{\delta K_2} = \frac{2K_2(1+K_1)}{(K_2-2)(2+K_1K_2)} = \frac{2(0.1)(1+100)}{(0.1-2)(2+(100)(0.1))} = -0.89$$

54.

a. Using Mason's rule:

$$T_1 = 1; \text{ Loops } L_1 = \frac{K_t}{s^2 + \omega_0^2} \frac{1}{M_{US}} \frac{\varepsilon}{s + \varepsilon} m_r = +\frac{\omega_0^2}{s^2 + \omega_0^2} \frac{\varepsilon}{s + \varepsilon} m_r \text{ and } L_2 = -\frac{\varepsilon m_r}{s + \varepsilon}, \text{ no}$$

$$\text{non-touching loops. } \Delta_1 = 1 + \frac{\varepsilon m_r}{s + \varepsilon}$$

$$\frac{E}{R} = \frac{T_1 \Delta_1}{\Delta} = \frac{1 + \frac{\varepsilon m_r}{s + \varepsilon}}{1 + m_r \frac{\varepsilon}{s + \varepsilon} - \frac{\omega_0^2}{s^2 + \omega_0^2} \frac{\varepsilon}{s + \varepsilon} m_r}$$

b. For a unit step input,

$$e_{ss} = \lim_{s \rightarrow 0} s \frac{1 + \frac{\mathcal{E}m_r}{s + \mathcal{E}}}{1 + m_r \frac{\mathcal{E}}{s + \mathcal{E}} - \frac{\omega_0^2}{s^2 + \omega_0^2} \frac{\mathcal{E}}{s + \mathcal{E}} m_r} \frac{1}{s} = \frac{1 + m_r}{1 + m_r - m_r} = 1 + m_r$$

c. For a unit ramp input,

$$e_{ss} = \lim_{s \rightarrow 0} s \frac{1 + \frac{\mathcal{E}m_r}{s + \mathcal{E}}}{1 + m_r \frac{\mathcal{E}}{s + \mathcal{E}} - \frac{\omega_0^2}{s^2 + \omega_0^2} \frac{\mathcal{E}}{s + \mathcal{E}} m_r} \frac{1}{s^2} = \infty$$

d. The system is type 0.

55.

a. Using Eq. (7.89) with

$$(\mathbf{sI} - \mathbf{A})^{-1} = \frac{1}{s^3 + 20s^2 + 111s + 164} \begin{bmatrix} s^2 + 15s + 50 & -(4s + 22) & -(2s + 20) \\ -(3s + 15) & s^2 + 10s + 23 & 6 \\ -(s + 13) & s + 9 & s^2 + 15s + 38 \end{bmatrix}$$

yields  $e(\infty) = 1.09756$  for a step input and  $e(\infty) = \infty$  for a ramp input. The same results are obtained using

$$\mathbf{A}^{-1} = -\frac{1}{164} \begin{pmatrix} 50 & -22 & -20 \\ -15 & 23 & 6 \\ -13 & 9 & 38 \end{pmatrix}$$

and Eq. (7.96) for a step input and Eq. (7.103) for a ramp input.

b. Using Eq. (7.89) with

$$(\mathbf{sI} - \mathbf{A})^{-1} = \frac{1}{s^3 + 9s^2 + 5s + 7} \begin{bmatrix} s^2 + 9s & s & 7 \\ -(5s + 7) & s^2 & 7s \\ -(s + 9) & -1 & s^2 + 9s + 5 \end{bmatrix}$$

yields  $e(\infty) = 0$  for a step input and  $e(\infty) = \frac{5}{7}$  for a ramp input. The same results are obtained using

$$\mathbf{A}^{-1} = -\frac{1}{7} \begin{pmatrix} 0 & 0 & 7 \\ -7 & 0 & 0 \\ -9 & -1 & 5 \end{pmatrix}$$

and Eq. (12.123) for a step input and Eq. (12.130) for a ramp input.

c. Using Eq. (7.89) with

$$(s\mathbf{I} - \mathbf{A})^{-1} = \frac{1}{s^3 + 14s^2 + 43s + 17} \begin{pmatrix} s^2 + 5s - 4 & -5s - 23 & -s + 10 \\ s + 11 & s^2 + 14s + 42 & -2s - 19 \\ -3s - 2 & -2s - 3 & s^2 + 9s + 5 \end{pmatrix}$$

yields  $e(\infty) = 6$  for a step input and  $e(\infty) = \infty$  for a ramp input. The same results are obtained using

$$\mathbf{A}^{-1} = -\frac{1}{17} \begin{pmatrix} -4 & -23 & 10 \\ 11 & 42 & -19 \\ -2 & -3 & 5 \end{pmatrix}$$

and Eq. (7.96) for a step input and Eq. (7.103) for a ramp input.

56.

**Find  $G_4(s)$ :** Since 100 mi/hr = 146.67 ft/sec, the velocity response of  $G_4(s)$  to a step displacement of the accelerator is  $v(t) = 146.67(1 - e^{-\alpha t})$ . Since 60 mi/hr = 88 ft/sec, the velocity equation at 10 seconds becomes  $88 = 146.67(1 - e^{-\alpha 10})$ . Solving for  $\alpha$  yields  $\alpha = 0.092$ . Thus,  $G_4(s) = \frac{K_1}{s+0.092}$ . But, from

the velocity equation, the dc value of  $G_4(s)$  is  $\frac{K_1}{0.092} = 146.67$ . Solving for  $K_1$ ,  $G_4(s) = \frac{13.49}{s+0.092}$ .

**Find error:** The forward transfer function of the velocity control loop is

$$G_3(s)G_4(s) = \frac{13.49K}{s(s+1)(s+0.092)}. \text{ Therefore, } K_v = \frac{13.49K}{0.092}. \text{ } e(\infty) = \frac{1}{K_v} = 6.82 \times 10^{-3}K.$$

57.

First, reduce the system to an equivalent unity feedback system. Push  $K_1$  to the right past the summing junction.

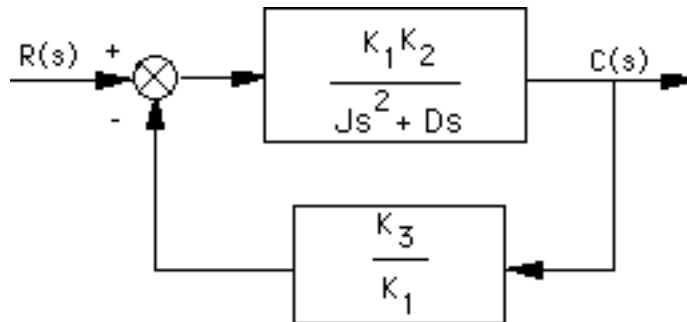

Convert to a unity feedback system by adding a unity feedback path and subtracting unity from  $\frac{K_1}{K_3}$ .

The equivalent forward transfer function is,

$$G_e(s) = \frac{\frac{K_1K_2}{Js^2+Ds}}{1 + \frac{K_1K_2}{Js^2+Ds} \left( \frac{K_3}{K_1} - 1 \right)} = \frac{K_1K_2}{Js^2 + Ds + K_2(K_3 - K_1)}$$

The system is Type 0 with  $K_p = \frac{K_1}{K_3 - K_1}$ . Assuming the input concentration is  $R_0$ ,

$$e(\infty) = \frac{R_0}{1+K_p} = \frac{R_0(K_3 - K_1)}{K_3}. \text{ The error can be reduced if } K_3 = K_1.$$

58.

a. For the inner loop,  $G_{1e}(s) = \frac{K \frac{(s+0.01)}{s^2}}{1+K \frac{(s+0.01)}{s^2}} = \frac{K(s+0.01)}{s^2+Ks+0.01K}$ , where  $K = \frac{K_c}{J}$ .

Form  $G_e(s) = G_{1e}(s) \frac{(s+0.01)}{s^2} = K \frac{(s+0.01)^2}{s^2(s^2+Ks+0.01K)}$ .

System is Type 2. Therefore,  $e_{\text{step}} = 0$ ,

b.  $e_{\text{ramp}} = 0$ ,

c.  $e_{\text{parabola}} = \frac{1}{K_a} = \frac{1}{0.01} = 100$

d.  $T(s) = \frac{G_e(s)}{1+G_e(s)} = \frac{K(s+0.01)^2}{s^4+Ks^3+1.01Ks^2+0.02Ks+10^{-4}K}$

$s^4$	1	1.01K	$10^{-4}K$	
$s^3$	K	0.02K	0	$0 < K$
$s^2$	$1.01K-0.02$	$10^{-4}K$	0	$0.0198 < K$
$s^1$	$\frac{0.0201 K^2 - 0.0004 K}{1.01 K - 0.02}$	0	0	$0.0199 < K$
$s^0$	$10^{-4}K$			$0 < K$

Thus, for stability  $K = \frac{K_c}{J} > 0.0199$

59.

a. Following Figure P7.29, the transfer function from  $\delta_f$  to  $e$  is given by:

$$\frac{e}{\delta_f} = \frac{r^* - G_f}{1 + KG_r}$$

For  $\delta_f = \frac{1}{s}$  we have that in steady state

$$e(\infty) = \frac{0.8 - \frac{b_2}{a_2}}{1 + K(0) \frac{b_4}{a_2}}$$

It can be seen from this expression that if  $K(s)$  is type 1 or larger  $e(\infty) = 0$ .

b. From Figure P7.29:

$$\frac{r}{\delta_f} = \frac{G_f + r^* K G_r}{1 + K G_r}$$

The error is now defined as

$$1 - \frac{r}{\delta_f} = 1 - \frac{G_f + r^* K G_r}{1 + K G_r} = \frac{1 + K G_r - G_f + r^* K G_r}{1 + K G_r}$$

In steady state this expression becomes:

$$1 - \frac{r}{\delta_f}(0) = \frac{1 + K(0) \frac{b_4}{a_2} - \frac{b_2}{a_2} - 0.8K(0) \frac{b_4}{a_2}}{1 + K(0) \frac{b_4}{a_2}} = \frac{1 + 0.2K(0) \frac{b_4}{a_2} - \frac{b_2}{a_2}}{1 + K(0) \frac{b_4}{a_2}}$$

It can be seen in this equation that the steady state error cannot be made zero.

## SOLUTIONS TO DESIGN PROBLEMS

60.

Pot gains:  $K_1 = \frac{3\pi}{\pi} = 3$ ; Amplifier gain:  $K_2$ ; Motor transfer function: Since time constant = 0.5,  $\alpha$

= 2. Also,  $\frac{K}{\alpha} = \frac{100}{10} = 10$ . Hence,  $K = 20$ . The motor transfer function is now computed as  $\frac{C(s)}{E_a(s)} = \frac{20}{s(s+2)}$ . The following block diagram results after pushing the potentiometers to the right past the

summing junction:





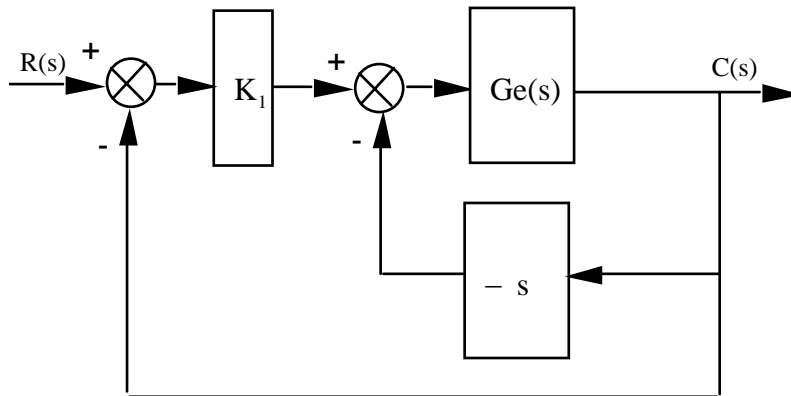
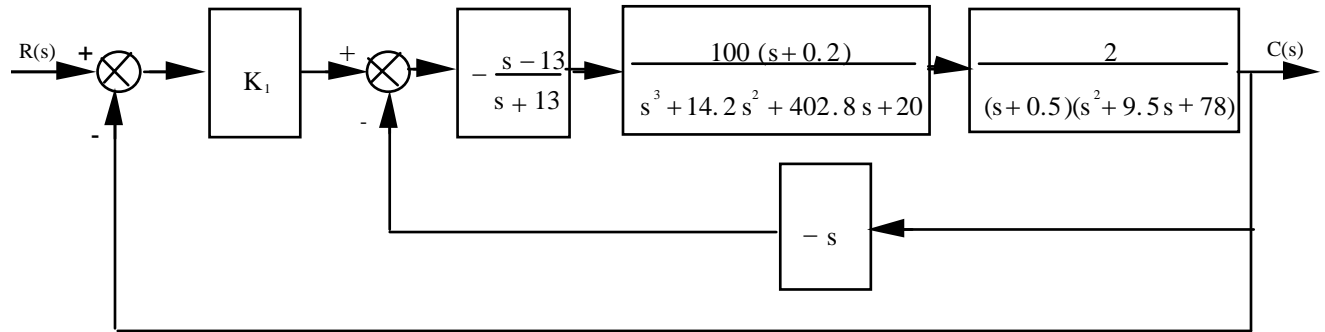

$$G_e(s) = (-200) \frac{s^2 - 12.8s - 2.6}{s^7 + 37.2s^6 + 942.15s^5 + 13420s^4 + 1.0249 \times 10^5 s^3 + 4.6048 \times 10^5 s^2 + 2.2651 \times 10^5 s + 10140}$$

System is unity feedback with a forward transfer function,  $G_t(s)$ , where

$$G_t(s) = -200 K_1 \frac{s^2 - 12.8s - 2.6}{s^7 + 37.2s^6 + 942.15s^5 + 13420s^4 + 1.0269 \times 10^5 s^3 + 4.5792 \times 10^5 s^2 + 2.2599 \times 10^5 s + 10140}$$

Thus, system is Type 0.

b. From  $G_t(s)$ ,  $K_p = \frac{520K_1}{10140} = 700$ . Thus,  $K_1 = 13650$ .

c.  $T(s) = \frac{G_t}{1 + G_t}$

For  $K_1 = 13650$ ,

$$T(s) = -2730000 \frac{s^2 - 12.8s - 2.6}{s^7 + 37.2s^6 + 942.15s^5 + 13420s^4 + 1.0269 \times 10^5 s^3 - 2.2721 \times 10^6 s^2 + 3.517 \times 10^7 s + 7108140}$$

Because of the negative coefficient in the denominator the system is unstable and the pilot would not be hired.

63.

The force error is the actuating signal. The equivalent forward-path transfer function is

$$G_e(s) = \frac{K_1}{s(s + K_1K_2)}. \text{ The feedback is } H(s) = D_e s + K_e. \text{ Using Eq. (7.72)}$$

$$E_a(s) = \frac{R(s)}{1 + G_e(s)H(s)}. \text{ Applying the final value theorem,}$$

$$e_{a\_ramp}(\infty) = \lim_{s \rightarrow 0} \frac{s \left( \frac{1}{s^2} \right)}{1 + \frac{K_1(D_e s + K_e)}{s(s + K_1K_2)}} = \frac{K_2}{K_e} < 0.1. \text{ Thus, } K_2 < 0.1K_e. \text{ Since the closed-loop system}$$

is second-order with positive coefficients, the system is always stable.

64.

a. The minimum steady-state error occurs for a maximum setting of gain,  $K$ . The maximum  $K$  possible is determined by the maximum gain for stability. The block diagram for the system is shown below.

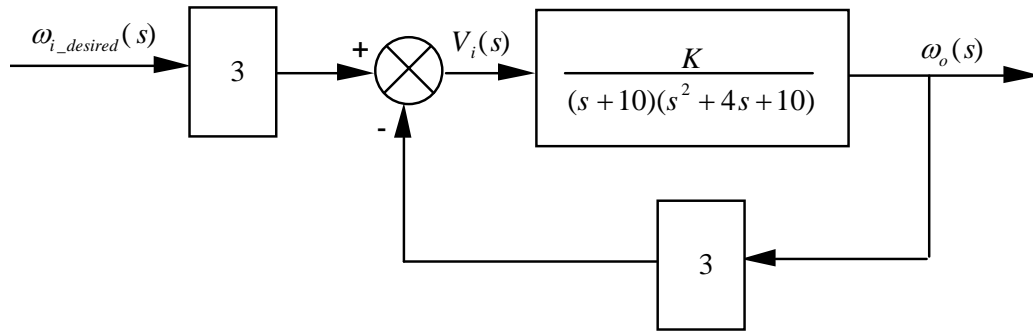

Pushing the input transducer to the right past the summing junction and finding the closed-loop transfer function, we get

$$T(s) = \frac{\frac{3K}{(s+10)(s^2+4s+10)}}{1 + \frac{3K}{(s+10)(s^2+4s+10)}} = \frac{3K}{s^3 + 14s^2 + 50s + (3K + 100)}$$

Forming a Routh table,

$s^3$	1	50
$s^2$	14	$3K+100$
$s^1$	$\frac{-3K + 600}{14}$	0
$s^0$	$3K+100$	0

The  $s^1$  row says  $-\infty < K < 200$ . The  $s^0$  row says  $-\frac{100}{3} < K$ . Thus for stability,

$-\frac{100}{3} < K < 200$ . Hence, the maximum value of  $K$  is 200.

b.  $K_p = \frac{3K}{100} = 6$ . Hence,  $e_{step}(\infty) = \frac{1}{1 + K_p} = \frac{1}{7}$ .

c. Step input.

65.

Substituting values we have  $P(s) = \frac{140625e^{-0.1s}}{(s + 2.67)(s + 10)}$ ,  $G(s) = \frac{0.005L}{s + 0.005}$

The proportional error constant

$$K_p = \lim_{s \rightarrow 0} G(s)P(s) = \lim_{s \rightarrow 0} \frac{0.005L}{s + 0.005} \frac{140625e^{-0.1s}}{(s + 2.67)(s + 10)} = 5273.44L$$

$$e_{ss} = \frac{1}{1 + K_p} = \frac{1}{1 + 5273.44L} = 0.1 \text{ which gives } L = 1.71 \times 10^{-3}.$$

66.

a. The open loop transmission is  $GP(s) = \frac{K_p s + K_I}{s^2} \frac{48500}{s + 2.89}$ . The system is type 2.

b. The Transfer function from disturbance to error signal is

$$\frac{E(s)}{D(s)} = -\frac{\frac{48500}{s^2 + 2.89s}}{1 + \frac{48500}{s^2 + 2.89s} \frac{K_p s + K_I}{s}} = -\frac{48500s}{s^3 + 2.89s^2 + 48500(K_p s + K_I)}$$

Using the Final value theorem

$$e_{ss} = \lim_{s \rightarrow 0} sE(s) = \lim_{s \rightarrow 0} s \left( -\frac{48500s}{s^3 + 2.89s^2 + 48500(K_p s + K_I)} \right) \frac{1}{s} = 0$$

c. We calculate  $K_a = \lim_{s \rightarrow 0} s^2 G(s)P(s) = \frac{48500K_I}{2.89}$  so  $e_{ss} = \frac{1}{K_a} = \frac{2.89}{48500K_I} = 0.05$ . So

we get  $K_I = 0.0120$

d. The system's characteristic equation is  $1 + \frac{48500}{s^2 + 2.89s} \frac{K_p s + 0.012}{s} = 0$  or

$s^3 + 2.89s^2 + 48500K_p s + 584.021 = 0$ . The Routh array is:

$s^3$	1	$48500 K_p$
$s^2$	2.89	584.021
$s$	$\frac{140165 K_p - 584.21}{2.89}$	
1	$48500 K_p$	

The dominant requirement is given by the third row  $K_p > 0.00417$

67.  
a.

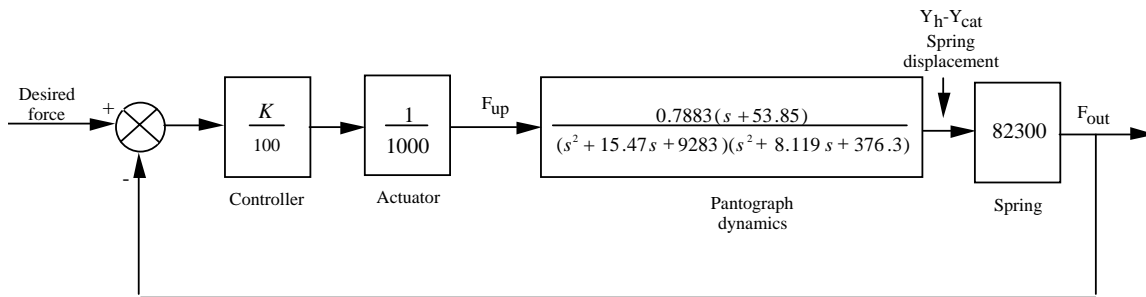
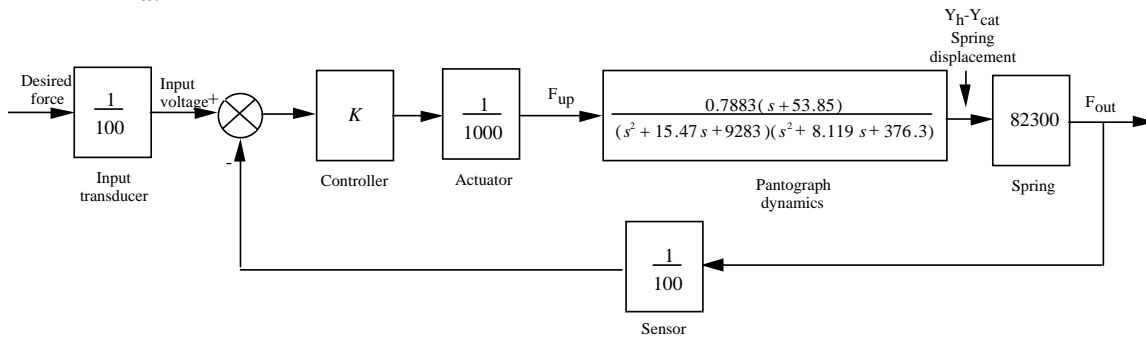

b.

$$G(s) = \frac{Y_h(s) - Y_{cat}(s)}{F_{up}(s)} = \frac{0.7883(s + 53.85)}{(s^2 + 15.47s + 9283)(s^2 + 8.119s + 376.3)}$$

$$Ge(s) = (K/100) * (1/1000) * G(s) * 82.3e3$$

$$G_e(s) = \frac{0.6488K(s + 53.85)}{(s^2 + 8.119s + 376.3)(s^2 + 15.47s + 9283)}$$

$$K_p = 0.6488K * 53.85 / [(376.3)(9283)] = K * 1.0002E-5$$

Maximum  $K$  minimizes the steady-state error. Maximum  $K$  possible is that which yields stability.

From Chapter 6 maximum  $K$  for stability is  $K = 1.88444 \times 10^5$ . Therefore,  $K_p = 1.8848$ .

c.  $e_{ss} = 1/(1+K_p) = 0.348$ .

68.

a. The system is Type 0 since there are no open-loop poles at the origin.

b. The open loop transfer function is:

$$KG(s)P(s) = K \frac{-520s - 10.3844}{s^3 + 2.6817s^2 + 0.11s + 0.012b}$$

$$\text{So that } K_p = \lim_{s \rightarrow 0} KG(s)P(s) = -824.16K$$

$$|e_{ss}| = \left| \frac{1}{1 + K_p} \right| = \left| \frac{1}{1 - 824.16K} \right| = 0.1 \text{ which results in } K = -0.1092.$$

$$s^4 + 2.6817s^3 + 0.11s^2 + (0.0126 - 520K)s + 10.3844K = 0$$

The Routh array is

69.

a. When the speed controller is configured as a proportional controller, the forward-path transfer function of this system is:

$$G(s) = \frac{0.11(s+0.6) \times K_{P_{SC}}}{s(s+0.5173) + 5(s+0.6) \times (s+0.01908)} \quad (1)$$

For the steady-state error for a unit-step input,  $r(t) = u(t)$ , to be equal to 1%:

$$e_{\text{step}}(\infty) = \frac{1}{1 + \lim_{s \rightarrow 0} G(s)} = \frac{1}{1 + \lim_{s \rightarrow 0} \left( \frac{0.11(s+0.6) \times K_{P_{SC}}}{s(s+0.5173) + 5(s+0.6) \times (s+0.01908)} \right)} = 0.01 \quad (2)$$

From equation (2), we get:  $\frac{1}{1 + \frac{0.11 \times 0.6 \times K_{P_{SC}}}{0 + 5 \times 0.6 \times 0.01908}} = 0.01$ , which yields:  $K_{P_{SC}} = 85.9$ .

b. When the speed controller is configured as a proportional plus integral controller, the forward-path transfer function of the system becomes:

$$G(s) = \frac{0.11(s+0.6) \times (100s + K_{I_{sc}})}{s[s(s+0.5173) + 5(s+0.6) \times (s+0.01908)]} \quad (3)$$

For the steady-state error for a unit-ramp input,  $r(t) = t u(t)$ , to be equal to 2.5%:

$$e_{\text{ramp}}(\infty) = \frac{1}{\lim_{s \rightarrow 0} s G(s)} = \frac{1}{\lim_{s \rightarrow 0} s \left( \frac{0.11(s+0.6) \times (100s + K_{I_{sc}})}{s[s(s+0.5173) + 5(s+0.6) \times (s+0.01908)]} \right)} = 0.025 \quad (4)$$

From equation (4), we get:  $\frac{1}{\frac{0.11 \times 0.6 \times K_{I_{sc}}}{0 + 5 \times 0.6 \times 0.01908}} = 0.025$ , which yields:  $K_{I_{sc}} = 34.7$ .

c. We'll start by finding  $G_I(s)$ , the equivalent transfer function of the parallel combination, representing the torque and speed controllers, shown in Figure P7.35:

$$G_1(s) = \frac{13.53s}{(s+0.5)} + \frac{3(s+0.6)}{(s+0.5)} \left( \frac{100s+40}{s} \right) = \frac{313.53s^2 + 300s + 72}{s(s+0.5)} \quad (5)$$

Given that the equivalent transfer function of the car is:  $G_2(s) = \frac{6.13 \times 10^{-3}}{s+0.01908}$ , we apply equation

7.62\* of the text taking into consideration that the disturbance here is a step with a magnitude equal to 83.7:

$$e(\infty) = -\frac{83.7}{\lim_{s \rightarrow 0} \frac{1}{G_2(s)} + \lim_{s \rightarrow 0} G_1(s)} = -\frac{83.7}{3.11 + \infty} = 0$$

# E I G H T

## Root Locus Techniques

### SOLUTIONS TO CASE STUDIES CHALLENGES

#### Antenna Control: Transient Design via Gain

a. From the Chapter 5 Case Study Challenge:

$$G(s) = \frac{76.39K}{s(s+150)(s+1.32)}$$

Since  $T_s = 8$  seconds, we search along  $-\frac{1}{2}$ , the real part of poles with this settling time, for  $180^\circ$ .

We find the point to be  $-0.5+j6.9$  with  $76.39K = 7194.23$ , or  $K = 94.18$ . Second-order approximation is OK since third pole is much more than 5 times further from the imaginary axis than the dominant second-order pair.

b.

#### Program:

```
numg= 1;
deng=poly([0 -150 -1.32]);
'G(s)'
G=tf(numg,deng)
rlocus(G)
axis([-2,0,-10,10]);
title(['Root Locus'])
grid on
[K1,p]=rlocfind(G)
K=K1/76.39
```

#### Computer response:

```
ans =
```

```
G(s)
```

```
Transfer function:
```

```
1
-----
s^3 + 151.3 s^2 + 198 s
```

```
Select a point in the graphics window
```

```
selected_point =
```

```
-0.5034 + 6.3325i
```

## 8-2 Chapter 8: Root Locus Techniques

```
K1 =  
    6.0690e+003  
  
p =  
    1.0e+002 *  
    -1.5027  
    -0.0052 + 0.0633i  
    -0.0052 - 0.0633i  
  
K =  
    79.4469  
  
>>  
ans =  
  
G(s)  
  
Transfer function:  
          1  
-----  
s^3 + 151.3 s^2 + 198 s  
  
Select a point in the graphics window  
selected_point =  
    -0.5000 + 6.2269i  
  
K1 =  
    5.8707e+003  
  
p =  
    1.0e+002 *  
    -1.5026  
    -0.0053 + 0.0623i  
    -0.0053 - 0.0623i  
  
K =  
    76.8521
```



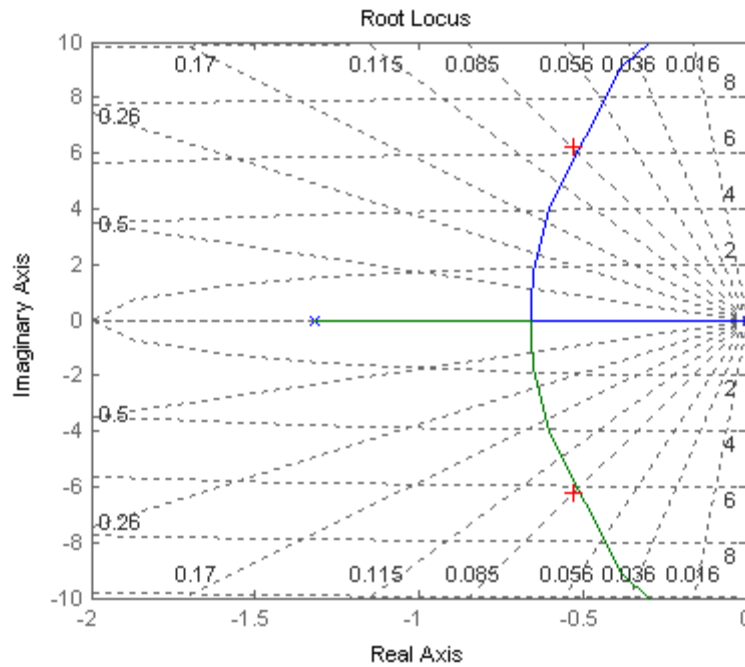

### UFSS Vehicle: Transient Design via Gain

a. Push  $-K_1$  to the right past the summing junction yielding  $G(s) = \frac{K(s+0.437)}{s(s+2)(s+1.29)(s+0.193)}$ , where

$K = 0.25K_1$ . Combine the parallel feedback paths and obtain  $H(s) = (s+1)$ . Hence,  $G(s)H(s) =$

$\frac{K(s+0.437)(s+1)}{s(s+2)(s+1.29)(s+0.193)}$ . The root locus is shown below in (b). Searching the 10% overshoot line ( $\zeta$

$= 0.591$ ;  $\theta = 126.24^\circ$ ), we find the operating point to be  $-1.07 \pm j1.46$  where  $K = 3.389$ , or  $K_1 = 13.556$ .

b.

#### Program:

```
numg= [1 0.437];
deng=poly([0 -2 -1.29 -0.193]);
G=tf(numg,deng);
numh=[1 1];
denh=1;
H=tf(numh,denh);
GH=G*H;
rlocus(GH)
pos=(10);
z=-log(pos/100)/sqrt(pi^2+[log(pos/100)]^2);
sgrid(z,0)
title(['Root Locus with ', num2str(pos), ' Percent Overshoot Line'])
[K,p]=rlocfind(GH);
pause
K1=K/0.25
T=feedback(K*G,H)
```

## 8-4 Chapter 8: Root Locus Techniques

```
T=minreal(T)
step(T)
title(['Step Response for Design of ', num2str(pos), ' Percent'])
```

### Computer response:

Select a point in the graphics window

selected\_point =

-1.0704 + 1.4565i

K1 =

13.5093

Transfer function:

$$3.377 s + 1.476$$

-----  
 $s^4 + 3.483 s^3 + 6.592 s^2 + 5.351 s + 1.476$

Transfer function:

$$3.377 s + 1.476$$

-----  
 $s^4 + 3.483 s^3 + 6.592 s^2 + 5.351 s + 1.476$

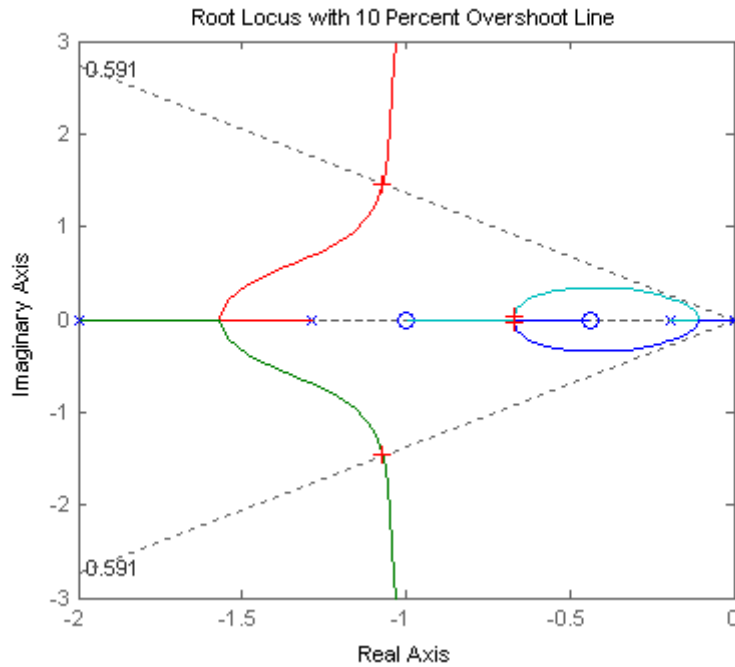

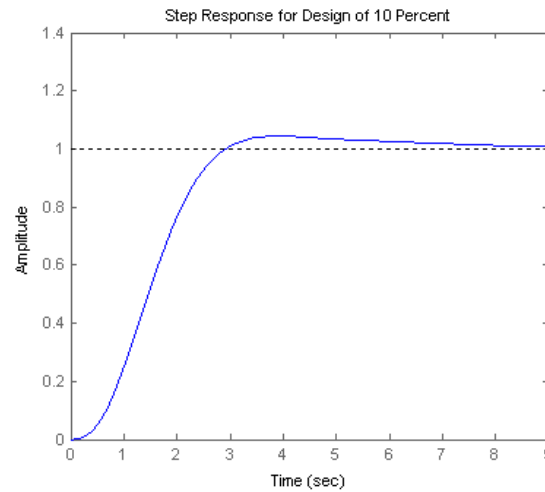

## ANSWERS TO REVIEW QUESTIONS

1. The plot of a system's closed-loop poles as a function of gain
2. (1) Finding the closed-loop transfer function, substituting a range of gains into the denominator, and factoring the denominator for each value of gain. (2) Search on the s-plane for points that yield 180 degrees when using the open-loop poles and zeros.
3.  $K = 1/5$
4. No
5. At the zeros of  $G(s)$  and the poles of  $H(s)$
6. (1) Apply Routh-Hurwitz to the closed-loop transfer function's denominator. (2) Search along the imaginary axis for 180 degrees.
7. If any branch of the root locus is in the rhp, the system is unstable.
8. If the branch of the root locus is vertical, the settling time remains constant for that range of gain on the vertical section.
9. If the root locus is circular with origin at the center
10. Determine if there are any break-in or breakaway points
11. (1) Poles must be at least five times further from the imaginary axis than the dominant second order pair, (2) Zeros must be nearly canceled by higher order poles.
12. Number of branches, symmetry, starting and ending points
13. The zeros of the open loop system help determine the root locus. The root locus ends at the zeros. Thus, the zeros are the closed-loop poles for high gain.

## SOLUTIONS TO PROBLEMS

1.
  - a. No: Not symmetric; On real axis to left of an even number of poles and zeros

- b.** No: On real axis to left of an even number of poles and zeros
- c.** No: On real axis to left of an even number of poles and zeros
- d.** Yes
- e.** No: Not symmetric; Not on real axis to left of odd number of poles and/or zeros
- f.** Yes
- g.** No: Not symmetric; real axis segment is not to the left of an odd number of poles
- h.** Yes

2.

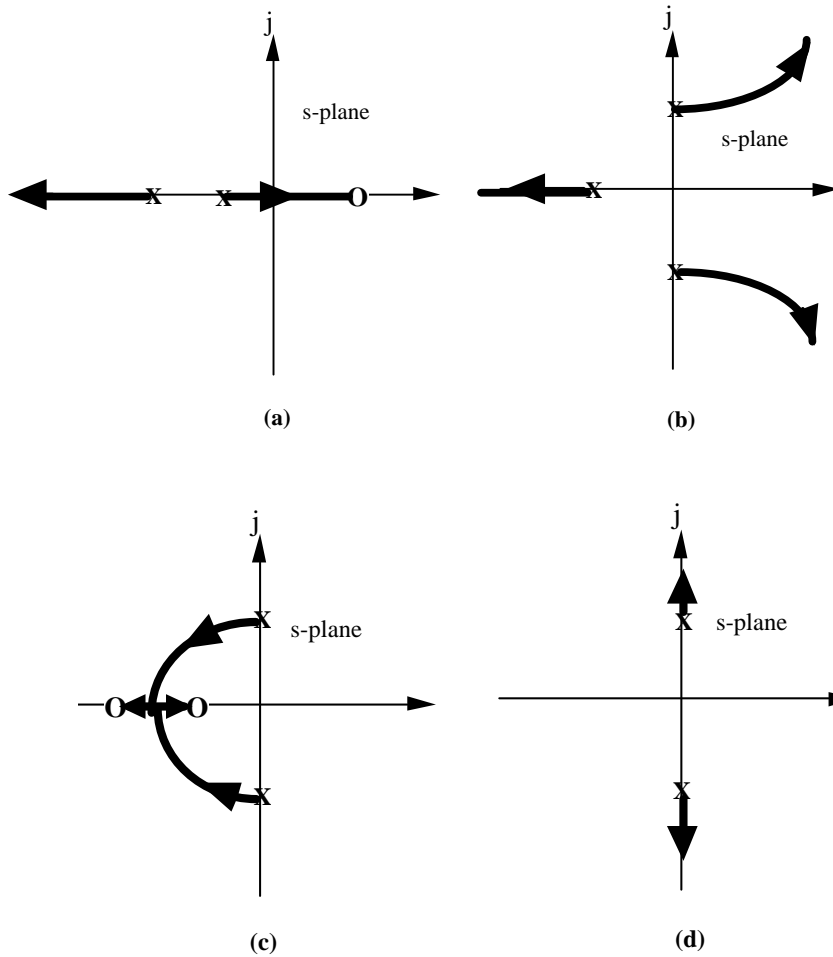

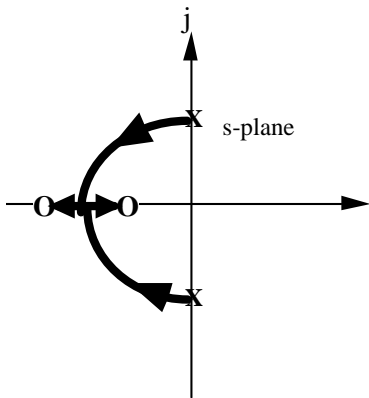

(c)

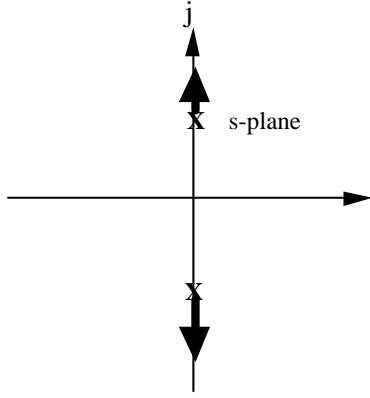

(d)

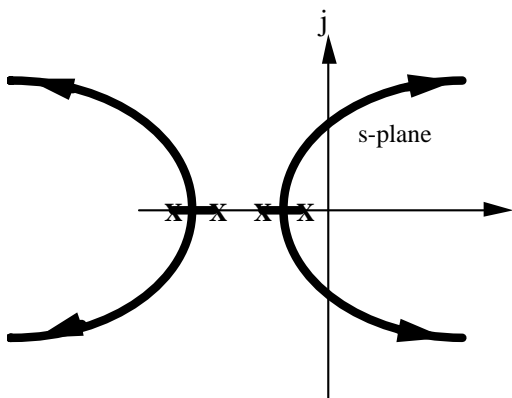

(e)

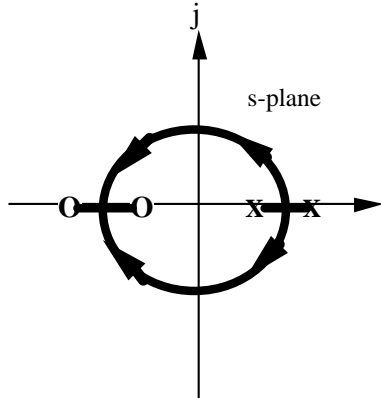

(f)

3.

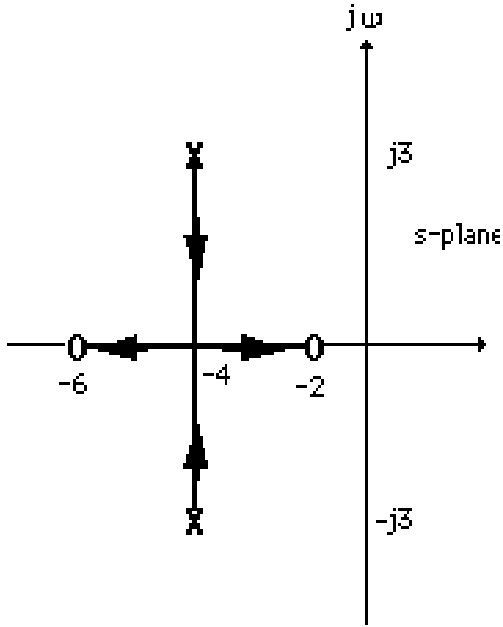

a.

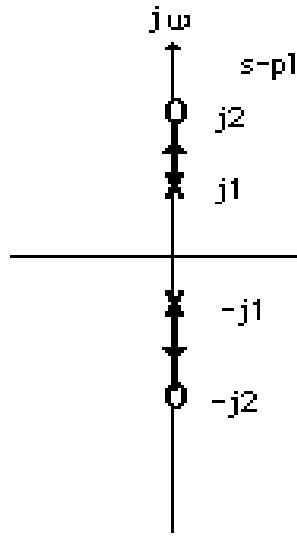

b.

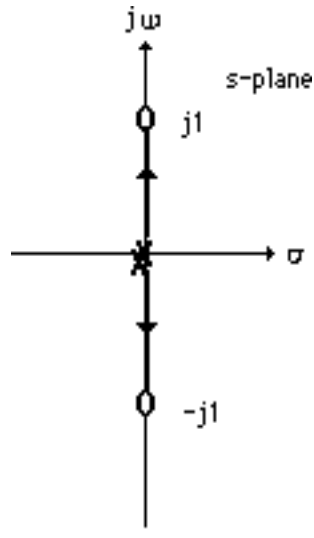

c.

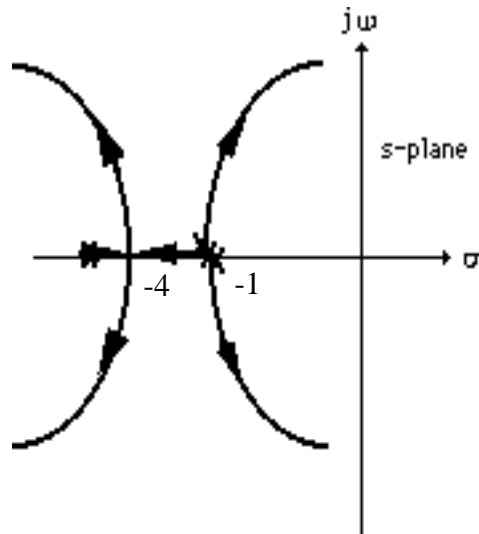

d.

4.

a. There are two asymptotes with  $\theta_a = \frac{\pi}{2}, \frac{3\pi}{2}$  and real axis intersection

$$\sigma_a = \frac{0+0-6-(-\frac{2}{3})}{3-1} = -2.67. \text{ The break-in and breakaway points are obtained by finding}$$

$$K = -\frac{\sigma^2(\sigma+6)}{\sigma+\frac{2}{3}} = -\frac{\sigma^3+6\sigma^2}{\sigma+\frac{2}{3}}. \text{ Obtaining}$$

$$\frac{dK}{d\sigma} = -\frac{\left(\sigma+\frac{2}{3}\right)(3\sigma^2+12\sigma)-(\sigma^3+6\sigma^2)}{\left(\sigma+\frac{2}{3}\right)^2} = -\frac{2\sigma(\sigma+2)^2}{\left(\sigma+\frac{2}{3}\right)^2} \text{ and solving for the roots of the}$$

numerator we get:  $\sigma = 0, -2, -2$ . So the root locus looks as follows:

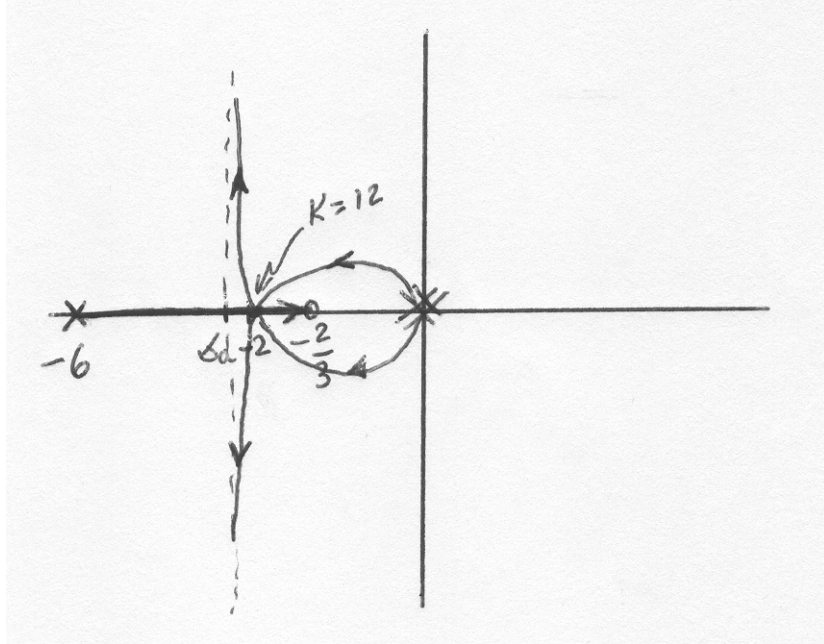

b. We can obtain  $K$  from  $1 + \frac{K \left( s + \frac{2}{3} \right)}{s^2(s+6)} \Big|_{s=-2} = 0$ , resulting in  $K = 12$ . Note that the open loop

zero will appear as a closed loop zero, so the closed loop transfer function is  $T(s) = \frac{12 \left( s + \frac{2}{3} \right)}{(s+2)^3}$

5.

a. The characteristic equation is given by  $1 - \frac{K(s+1)^2}{s^2 + 2s + 2} = 0$  or  $(1-K)s^2 + (2-2K)s + (2-K) = 0$ . The Routh array is

$s^2$	$1-K$	$2-K$
$s$	$2-2K$	
1	$2-K$	

For  $K > 0$ , the first column of the Routh array will have no sign changes when either  $K < 1$  or when  $K > 2$ . The system is closed loop unstable in the range  $1 < K < 2$ .

b. There are no asymptotes in this root locus. To calculate the break-in and breakaway points, let

$$K = \frac{\sigma^2 + 2\sigma + 2}{\sigma^2 + 2\sigma + 1}. \text{ Then}$$

$$\frac{dK}{d\sigma} = \frac{(\sigma^2 + 2\sigma + 1)(2\sigma + 2) - (\sigma^2 + 2\sigma + 2)(2\sigma + 2)}{(\sigma^2 + 2\sigma + 1)^2} = \frac{-2(\sigma + 1)}{(\sigma^2 + 2\sigma + 1)^2}$$

So the only

break-in point occurs when  $\sigma = -1$ .

It is helpful to calculate directly the root positions from the characteristic equation. The closed loop

$$\text{poles are located at } s_{1,2} = \frac{-2 + 2K \pm \sqrt{4(1-K)^2 - 4(1-K)(2-K)}}{2(1-K)} = \frac{-1 + K \pm \sqrt{K-1}}{1-K}$$

It can be seen that when  $K < 1$ , both poles are complex conjugate with a real part  $= -1$ ; when

$K > 2$  the two poles are real.

The root locus is:

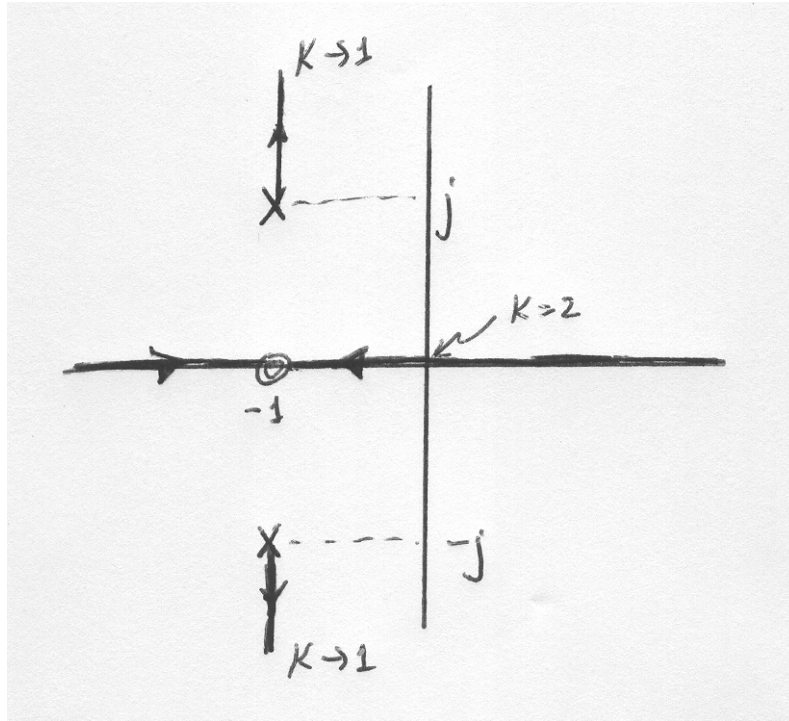

c. When  $K = 1$  the poles are at  $\infty$ . When  $K = 2$ , the solution of the quadratic equation above gives  $s = 0, -2$



6.

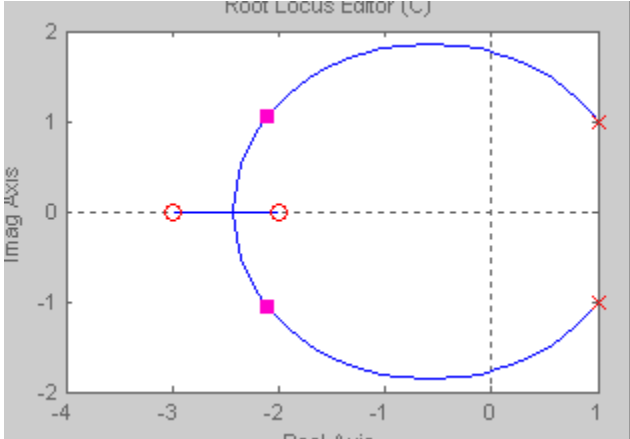

Break-in:  $\sigma = -2.43$  for  $K = 52.1$

7.

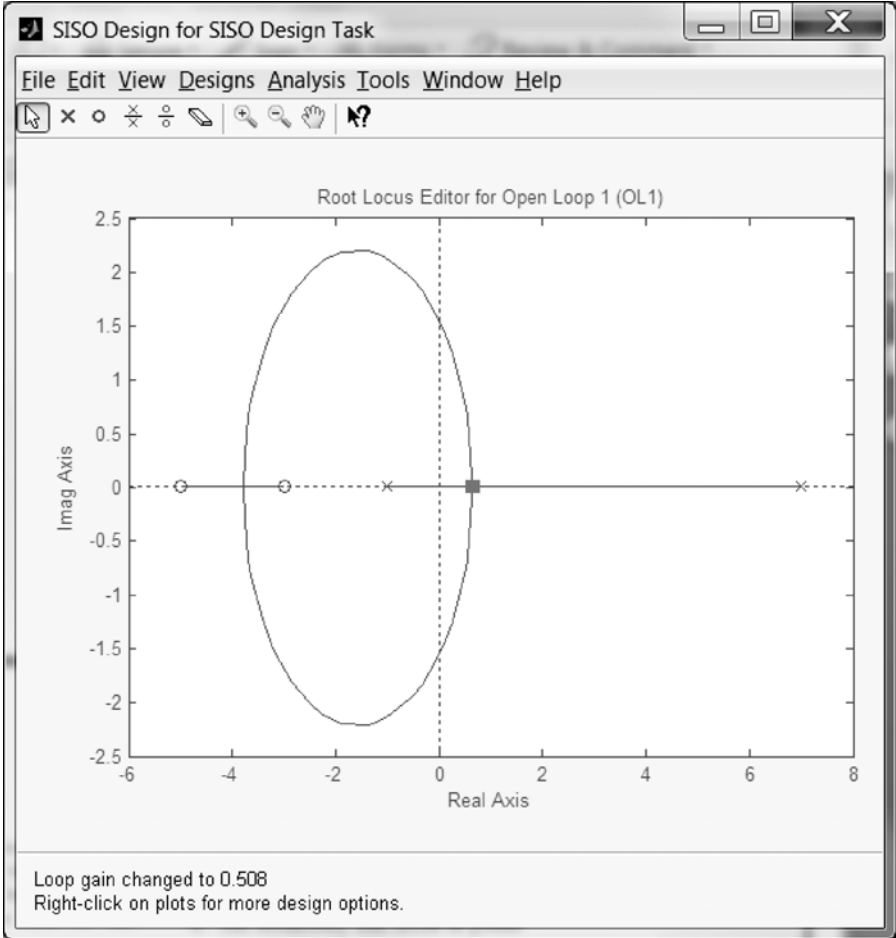

Break-in:  $\sigma = -3.78$  for  $K = 31.5$ ; Breakaway:  $\sigma = -0.661$  for  $K = 0.508$ .

8.

Convert the denominator to the following form:  $D(s) = 1 + \frac{20K(s+5)}{s^3 + 2s^2 + 7s}$  and thus identify

$$G(s) = \frac{20K(s+5)}{s^3 + 2s^2 + 7s} = \frac{20K(s+5)}{s(s^2 + 2s + 7)}$$

Plotting the root locus yields

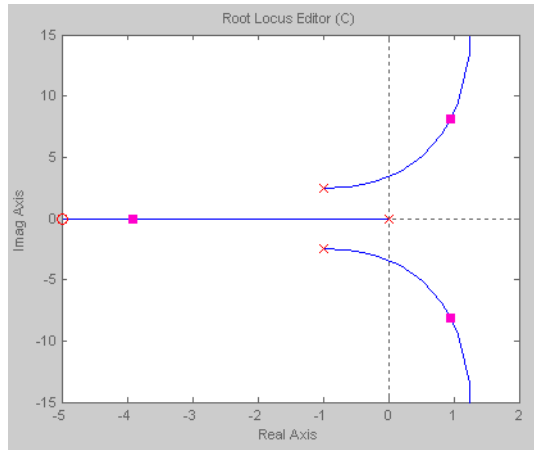

9.

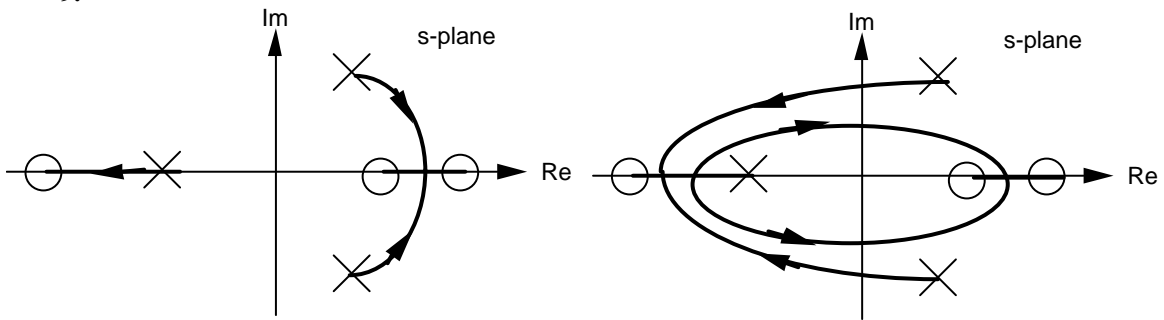

10.

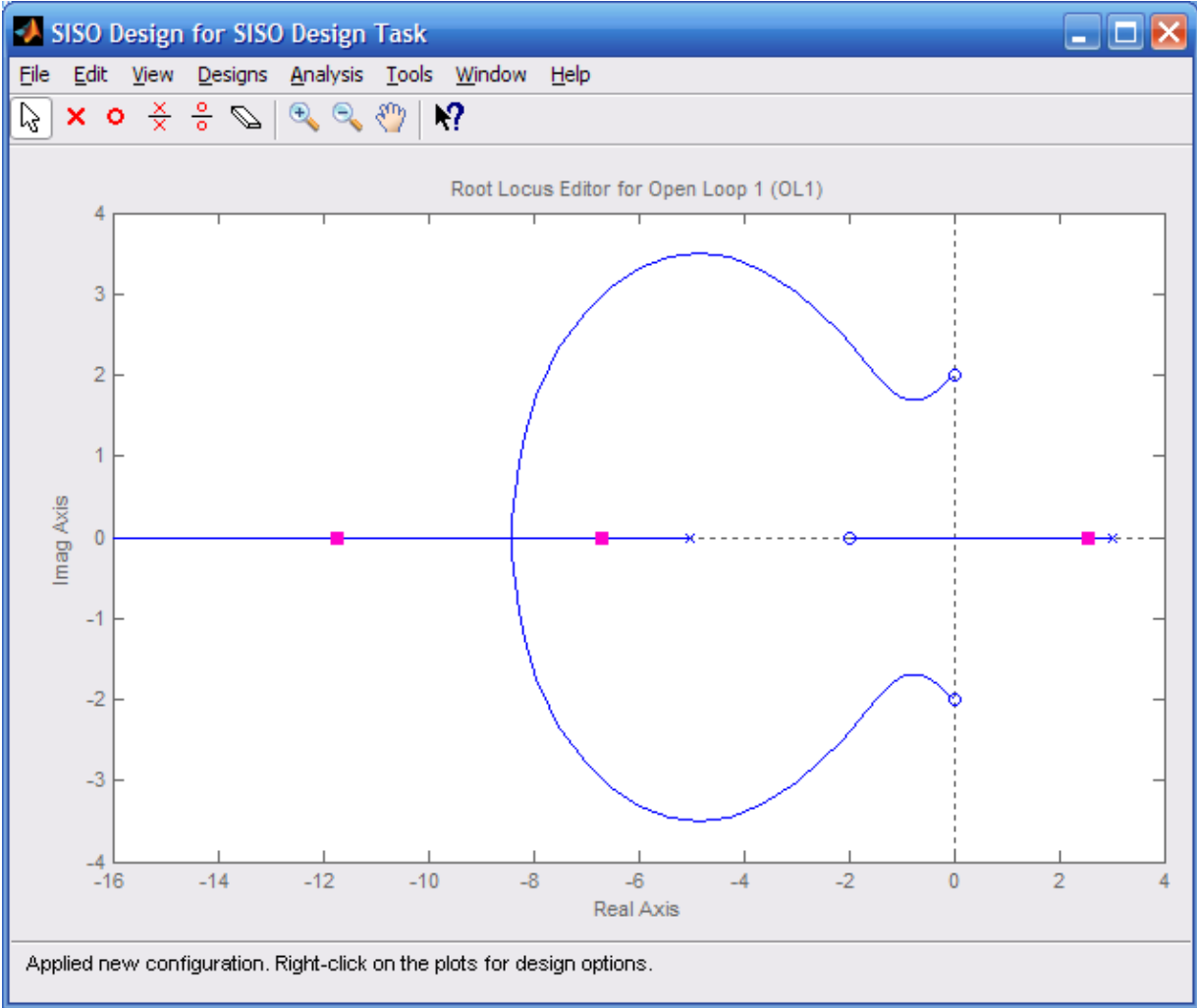

Closed-loop poles will be in the left-half-plane when rhp pole reaches the origin,

$$\text{or } K > \frac{(3)(5)}{(2)(2)(2)} = \frac{15}{8}. \text{ Thus, poles will be in the right half-plane for } K < \frac{15}{8}$$

11.

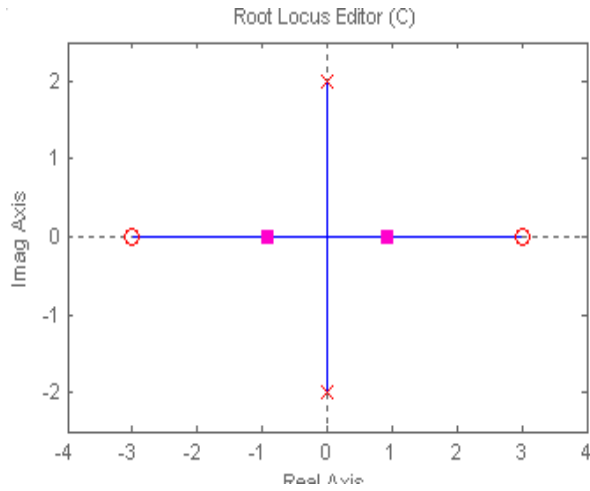

Closed-loop poles will be in the right-half-plane for  $K > \frac{(2)(2)}{(3)(3)} = \frac{4}{9}$  (gain at the origin).

Therefore, stable for  $K < 4/9$ ; unstable for  $K > 4/9$ .

12.

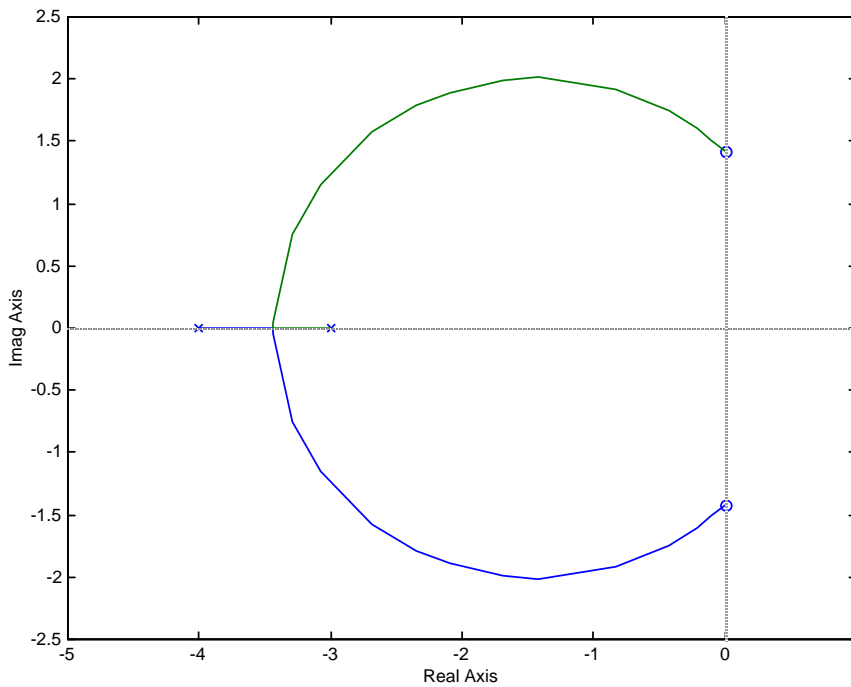

Breakaway:  $\sigma = -3.436$  for  $K = 1.781$ . System is never unstable. System is marginally stable for  $K =$

•

13. System 1:

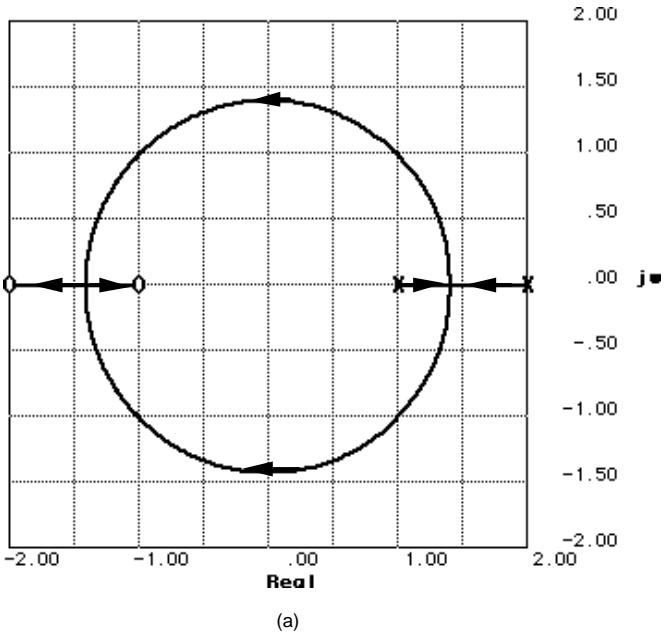

- a. Breakaway:  $\sigma = 1.41$  for  $K = 0.03$ ; Break-in:  $\sigma = -1.41$  for  $K = 33.97$ .
- b. Imaginary axis crossing at  $j1.41$  for  $K = 1$ . Thus stable for  $K > 1$ .
- c. At break-in point, poles are multiple. Thus,  $K = 33.97$ .
- d. Searching along  $135^\circ$  line for  $180^\circ$ ,  $K = 5$  at  $1.414 \angle 135^\circ$ .

System 2:

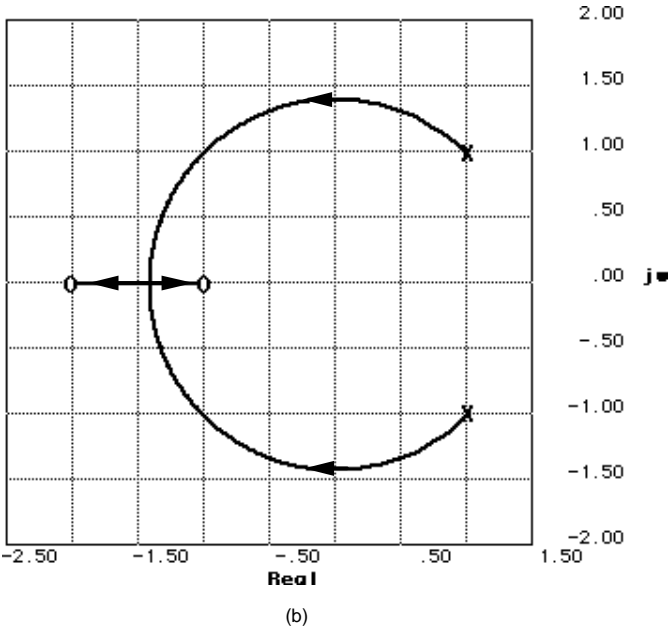

- a. Break-in:  $\sigma = -1.41$  for  $K = 28.14$ .

b. Imaginary axis crossing at  $j1.41$  for  $K = 0.67$ . Thus stable for  $K > 0.67$ .

c. At break-in point, poles are multiple. Thus,  $K = 28.14$ .

d. Searching along  $135^\circ$  line for  $180^\circ$ ,  $K = 4$  at  $1.414 \angle 135^\circ$ .

14.

a.

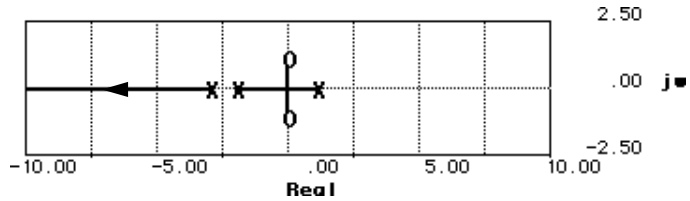

Root locus crosses the imaginary axis at the origin for  $K = 6$ . Thus the system is stable for  $K > 6$ .

b.

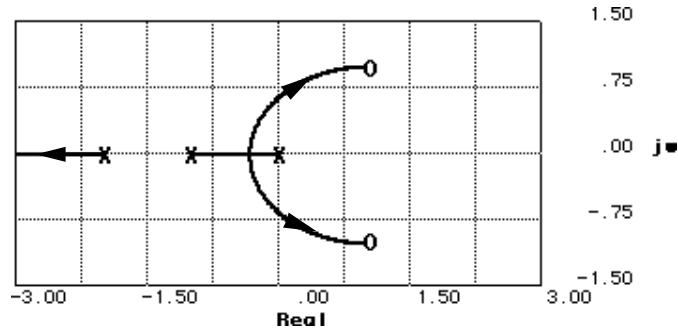

Root locus crosses the imaginary axis at  $j0.65$  for  $K = 0.79$ . Thus, the system is stable for  $K < 0.79$ .

15.

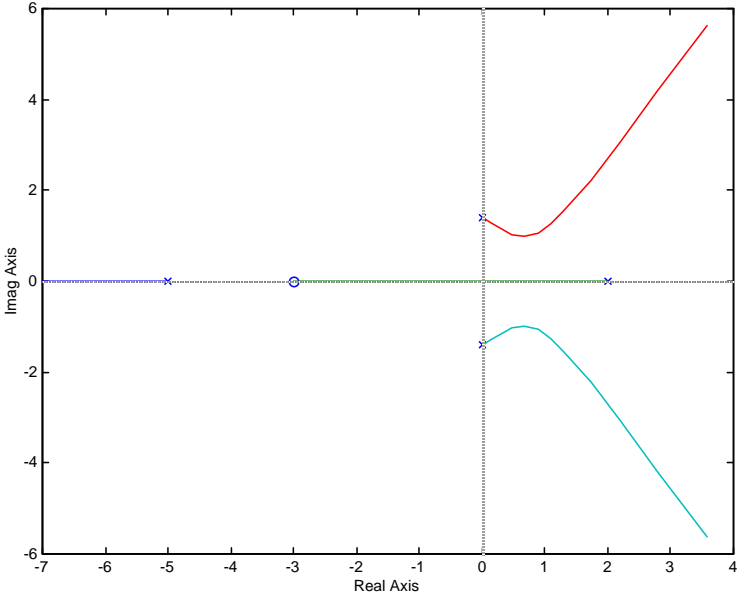

There will be only two right-half-plane poles when pole at +2 moves into the left-half-plane at the

origin. Thus  $K = \frac{(5)(\sqrt{2})(\sqrt{2})(2)}{3} = 6.67$ .

16.

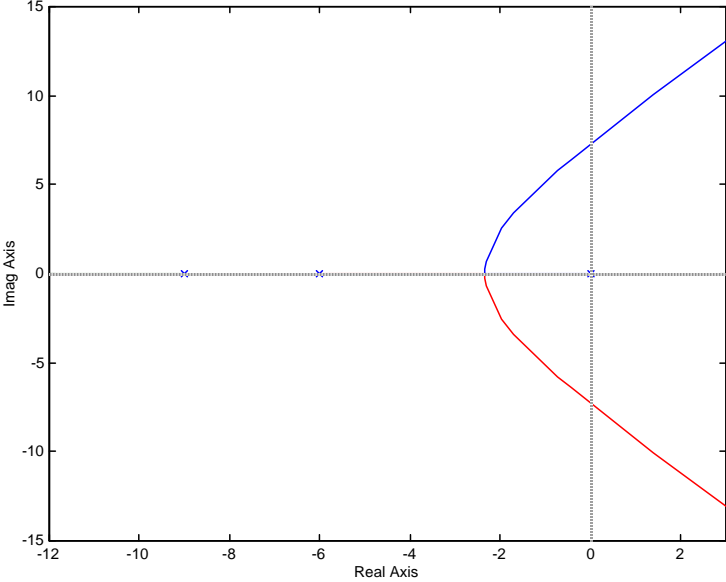

Root locus crosses the imaginary axis at  $j7.348$  with a gain of 810. Real axis breakaway is at  $-2.333$  at a gain of 57.04. Real axis intercept for the asymptotes is  $\frac{15}{3}$

5. The angle of the asymptotes is  $\frac{\pi}{3}$ ,  $\pi$ ,  $\frac{5\pi}{3}$ . Some other points on the root locus are:

$$\zeta = 0.4: -1.606 + j3.68, K = 190.1$$

$$\zeta = 0.6: -1.956 + j2.6075, K = 117.8$$

$$\zeta = 0.8: -2.189 + j1.642, K = 79.55$$

17.

a.

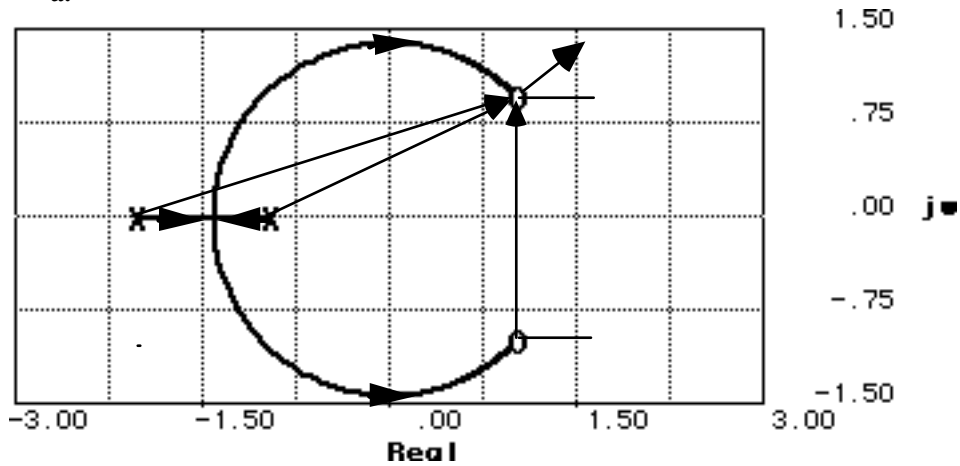

Imaginary axis crossing:  $j1.41$  at  $K = 1.5$ . Stability:  $K < 1.5$ . Breakaway:  $-1.41$  at  $K = 0.04$ . Points on root locus:  $-1.5 \pm j0$ ,  $K = 0.0345$ ;  $-0.75 \pm j1.199$ ,  $K = 0.429$ ;  $0 \pm j1.4142$ ,  $K = 1.5$ ;

$0.75 \pm j1.1989$ ,  $K = 9$ . Finding angle of arrival:  $90^\circ - \theta_1 - \theta_2 + \theta_3 = 90^\circ - \tan^{-1}(1/3) - \tan^{-1}(1/2) + \theta_3 = 180^\circ$ . Thus,  $\theta_3 = 135^\circ$ .

b.

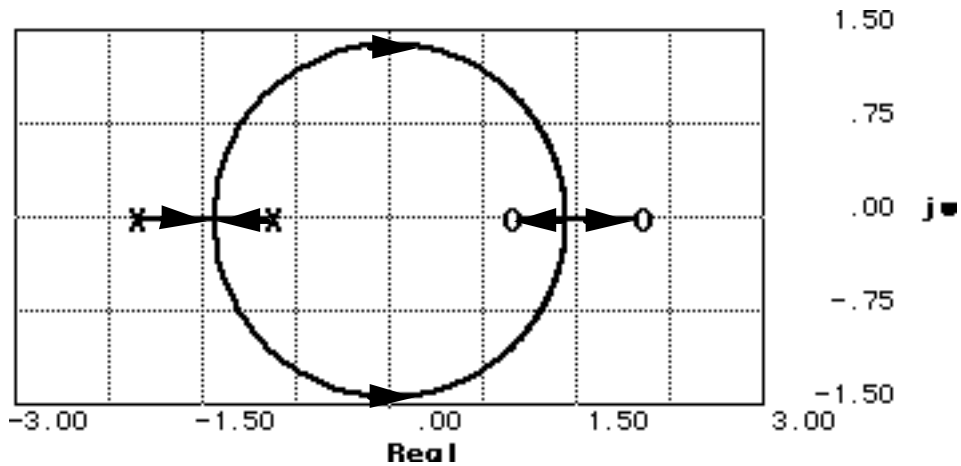



Imaginary axis crossing:  $j1.41$  at  $K = 1$ . Stability:  $K < 1$ . Breakaway:  $-1.41$  at  $K = 0.03$ . Break-in:  $1.41$  at  $K = 33.97$ . Points on root locus:  $-1.5 \pm j0$ ,  $K = 0.02857$ ;  $-0.75 \pm j1.199$ ,  $K = 0.33$ ;  $0 \pm j1.4142$ ,  $K = 1$ ;  $0.75 \pm j1.1989$ ,  $K = 3$ .

18.

a. Root locus crosses the imaginary axis at  $\pm j3.162$  at  $K = 52$ .

b. Since the gain is the product of pole lengths to  $-5$ ,  $K = (1)\left(\sqrt{4^2 + 1^2}\right)\left(\sqrt{4^2 + 1^2}\right) = 17$ .

19.

a.

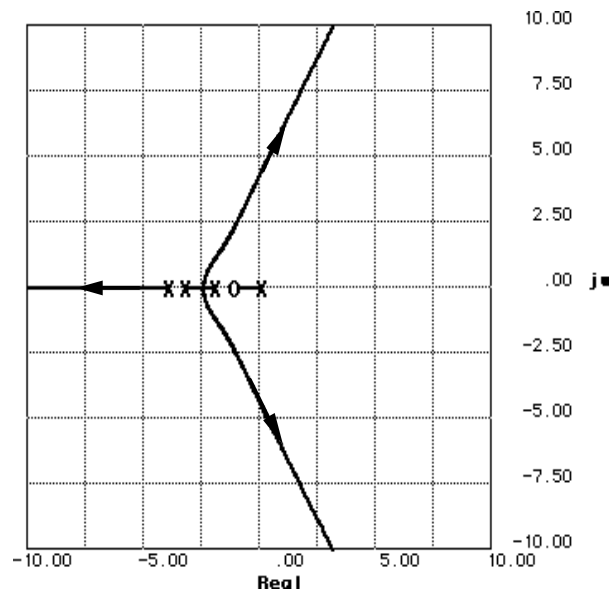

b.  $\sigma_a = \frac{(0 - 2 - 3 - 4) - (-1)}{3} = -\frac{8}{3}$ ; Angle =  $\frac{(2k+1)\pi}{3} = \frac{\pi}{3}, \pi, \frac{5\pi}{3}$

c. Root locus crosses imaginary axis at  $j4.28$  with  $K = 140.8$ .

d.  $K = 13.125$

20.

Assume that root locus is epsilon away from the asymptotes. Thus,  $\sigma_a = \frac{(0 - 3 - 6) - (-\alpha)}{2} = -1$ ;

Angle =  $\frac{(2k+1)\pi}{2} = \frac{\pi}{2}, \frac{3\pi}{2}$ . Hence  $\alpha = 7$ . Checking assumption at  $-1 \pm j100$  yields  $-180^\circ$  with  $K =$

9997.02.

21.

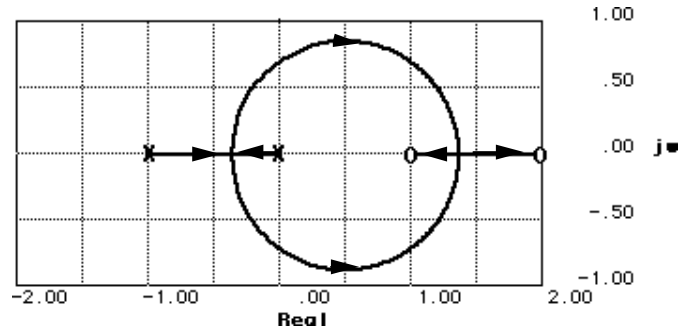

- a. Breakaway:  $-0.37$  for  $K = 0.07$ . Break-in:  $1.37$  for  $K = 13.93$
- b. Imaginary axis crossing:  $\pm j0.71$  for  $K = 0.33$
- c. System stable for  $K < 0.33$
- d. Searching  $120^\circ$  find point on root locus at  $0.5 \angle 120^\circ = -0.25 \pm j0.433$  for  $K = 0.1429$

22.

a.

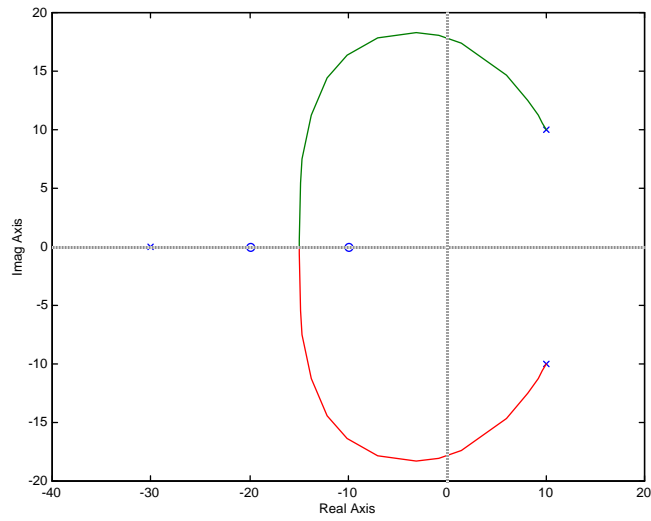

- b.  $23.93 < K < \infty$
- c.  $K = 81.83$  @  $-13.04 \pm j13.04$
- d. At the break-in point,  $s = -14.965$ ,  $K = 434.98$ .

23.

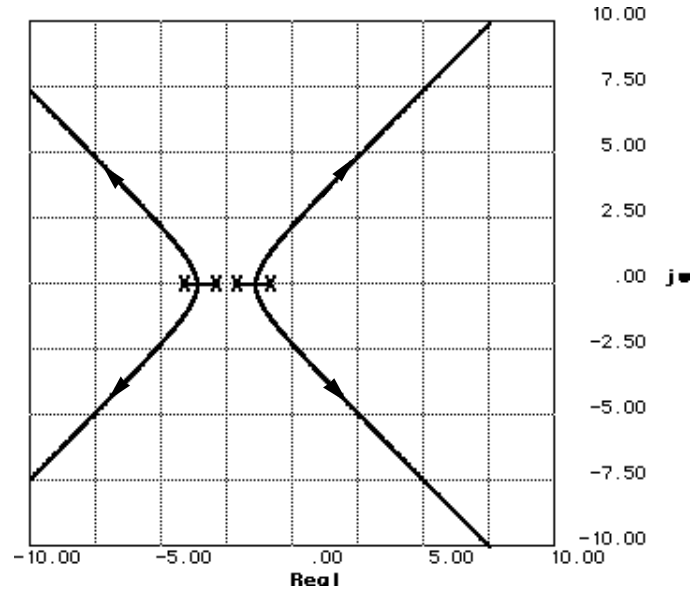

a. Asymptotes:  $\sigma_{\text{int}} = \frac{(-1 - 2 - 3 - 4) - (0)}{4} = -\frac{5}{2}$  ; Angle =  $\frac{(2k+1)\pi}{4} = \frac{\pi}{4}, \frac{3\pi}{4}, \frac{5\pi}{4}, \frac{7\pi}{4}$

b. Breakaway: -1.38 for  $K = 1$  and -3.62 for  $K = 1$

c. Root locus crosses the imaginary axis at  $\pm j2.24$  for  $K = 126$ . Thus, stability for  $K < 126$ .

d. Search 0.7 damping ratio line ( $134.427^\circ$ ) for  $180^\circ$ . Point is  $1.4171 \angle 134.427^\circ = -0.992 \pm j1.012$  for  $K = 10.32$ .

e. Without the zero, the angles to the point  $\pm j5.5$  add up to  $-265.074^\circ$ . Therefore the contribution of the zero must be  $265.074 - 180 = 85.074^\circ$ . Hence,  $\tan 85.074^\circ = \frac{5.5}{z_c}$ , where  $-z_c$  is the location of the zero. Thus,  $z_c = 0.474$ .

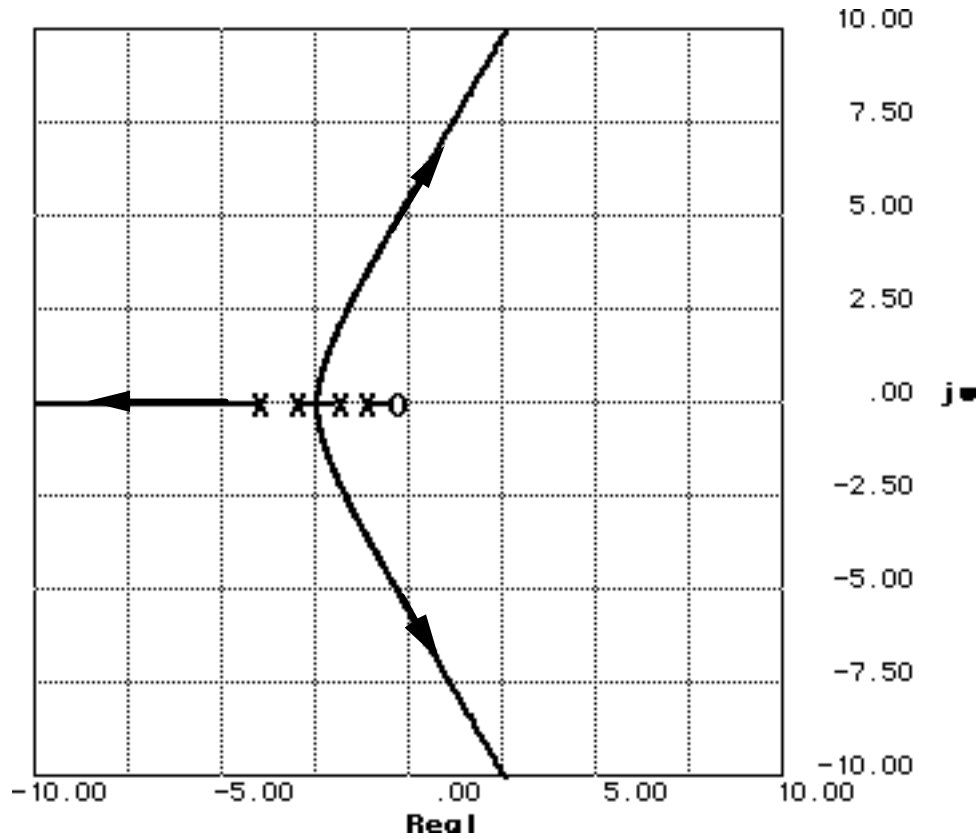

f. After adding the zero, the root locus crosses the imaginary axis at  $\pm j5.5$  for  $K = 252.5$ . Thus, the system is stable for  $K < 252.5$ .

g. The new root locus crosses the 0.7 damping ratio line at  $2.7318 \angle 134.427^\circ$  for  $K = 11.075$  compared to  $1.4171 \angle 134.427^\circ$  for  $K = 10.32$  for the old root locus. Thus, the new system's settling time is shorter, but with the same percent overshoot.

24.

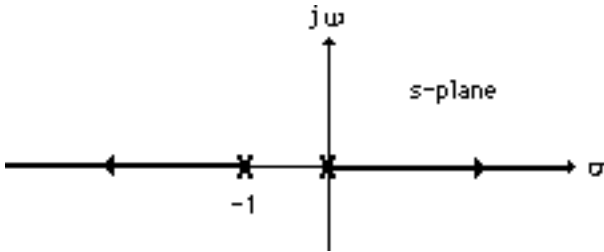

25.

$$T(s) = \frac{1}{s^2 + \alpha s + 1} = \frac{\frac{1}{s^2 + 1}}{1 + \frac{\alpha s}{s^2 + 1}}. \text{ Thus an equivalent system has } G(s) = \frac{1}{s^2 + 1} \text{ and } H(s) = \alpha s.$$

Plotting a root locus for  $G(s)H(s) = \frac{\alpha s}{s^2 + 1}$ , we obtain,

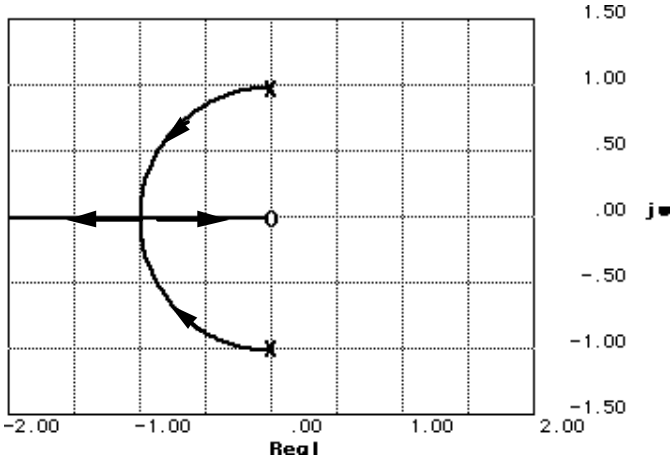

26.  
a.

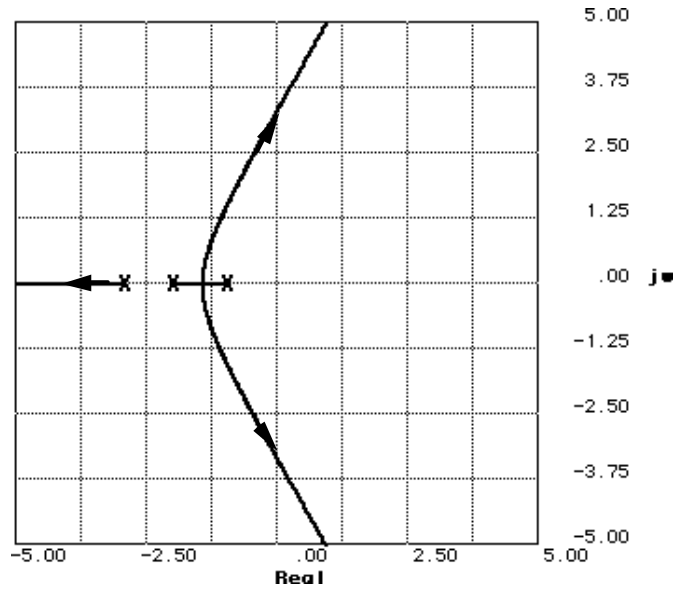

b. Root locus crosses 20% overshoot line at  $1.8994 \angle 117.126^\circ = -0.866 \pm j1.69$  for  $K = 9.398$ .

c.  $T_s = \frac{4}{0.866} = 4.62$  seconds;  $T_p = \frac{\pi}{1.69} = 1.859$  seconds

d. Other poles with same gain as dominant poles:  $\sigma = -4.27$

e. Root locus crosses imaginary axis at  $\pm j3.32$  for  $K = 60$ . Therefore stability for  $K < 60$ .

27.  
a.

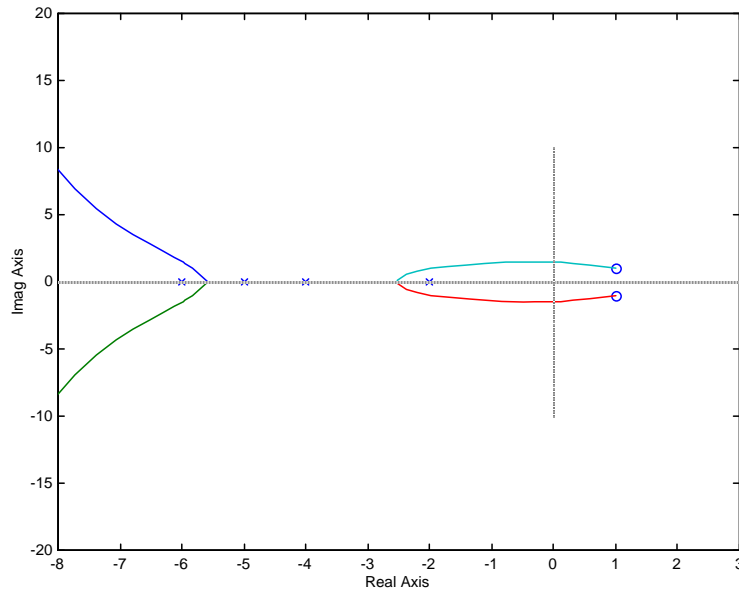

b.

$$^a \frac{(6 \ 5 \ 4 \ 2) \ (2)}{4 \ 2} \quad 9.5$$

$$^a \frac{(2k \ 1)}{4 \ 2} \quad \frac{3}{2}, \quad \frac{3}{2}$$

c. At the  $j\omega$  axis crossing,  $K = 115.6$ . Thus for stability,  $0 < K < 115.6$ .d. Breakaway points at  $\sigma = -2.524$  @  $K = 0.496$  and  $\sigma = -5.576$  @  $K = 0.031$ .e. For 25% overshoot, Eq. (4.39) yields  $\zeta = 0.404$ . Searching along this damping ratio line, we find the  $180^\circ$  point at  $-0.6608 + j1.496$  where  $K = 35.98$ .f.  $-7.839 \pm j7.425$ 

g. Second-order approximation not valid because of the existence of closed-loop zeros in the rhp.

h.

**Program:**

```
numg=35.98*[1 -2 2];
deng=poly([-2 -4 -5 -6]);
G=tf(numg,deng);
T=feedback(G,1)
step(T)
```

**Computer response:**

Transfer function:

$$35.98 s^2 - 71.96 s + 71.96$$

$$s^4 + 17 s^3 + 140 s^2 + 196 s + 312$$

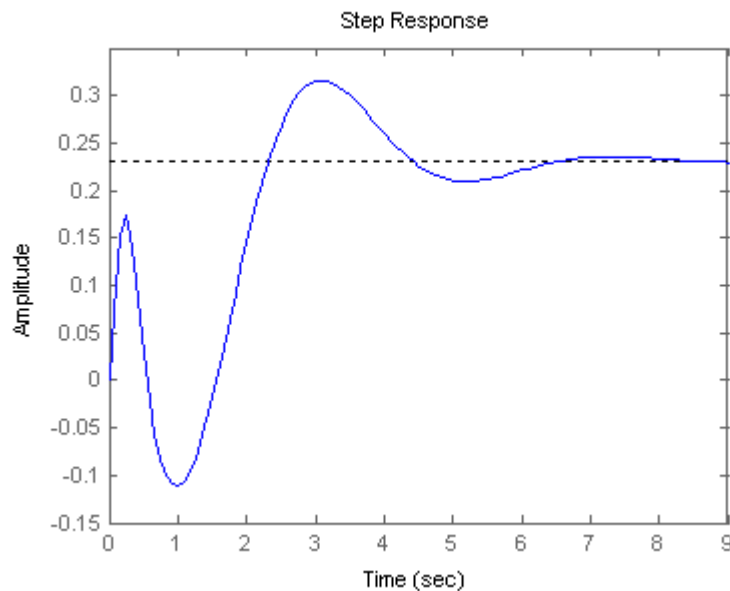

Simulation shows over 30% overshoot and nonminimum-phase behavior. Second-order approximation not valid.

28.

a. Draw root locus and minimum damping ratio line.

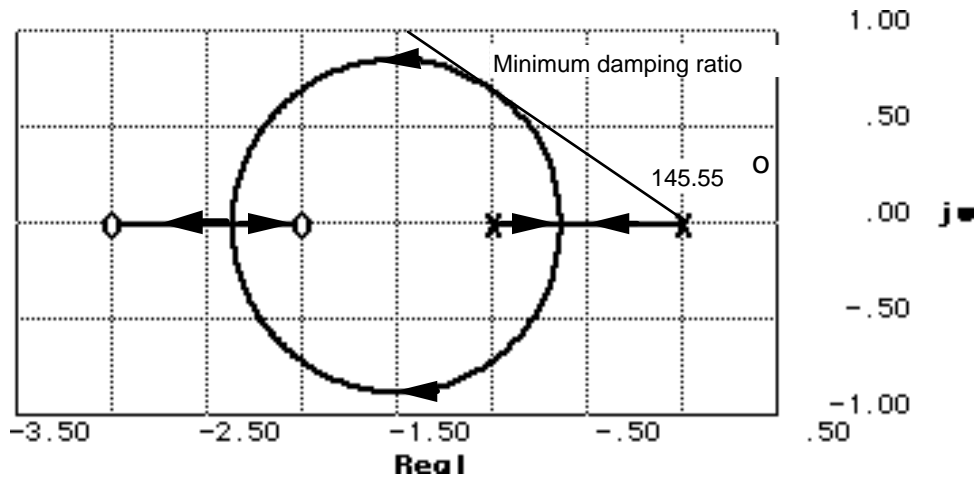

Minimum damping ratio is  $\zeta = \cos(180 - 145.55) = \cos 34.45^\circ = 0.825$ . Coordinates at tangent point of  $\zeta = 0.825$  line with the root locus is approximately  $-1 + j0.686$ . The gain at this point is 0.32.

b. Percent overshoot for  $\zeta = 0.825$  is 1.019%.c.  $T_s = \frac{4}{1} = 4$  seconds;  $T_p = \frac{\pi}{0.6875} = 4.57$  seconds

d. Second-order approximation is not valid because of the two zeros and no pole-zero cancellation.

e.  $K_v = \frac{0.32 * 2 * 3}{1} = 1.92$ ; Therefore,  $e_{ramp}(\infty) = \frac{1}{K_v} = 0.52$ .

29.

The root locus intersects the 0.55 damping ratio line at  $-7.217 + j10.959$  with  $K = 134.8$ . A justification of a second-order approximation is not required. The problem stated the requirements in terms of damping ratio and not percent overshoot, settling time, or peak time. A second-order approximation is required to draw the equivalency between percent overshoot, settling time, and peak time and damping ratio and natural frequency.

30.

Since the problem stated the settling time at large values of  $K$ , assume that the root locus is approximately close to the vertical asymptotes. Hence,  $\sigma_{int} = \frac{-11 + \alpha}{2} = -\frac{4}{T_s}$ . Since  $T_s$  is given as 4 seconds,  $\sigma_{int} = -1$  and  $\alpha = 9$ . The root locus is shown below.



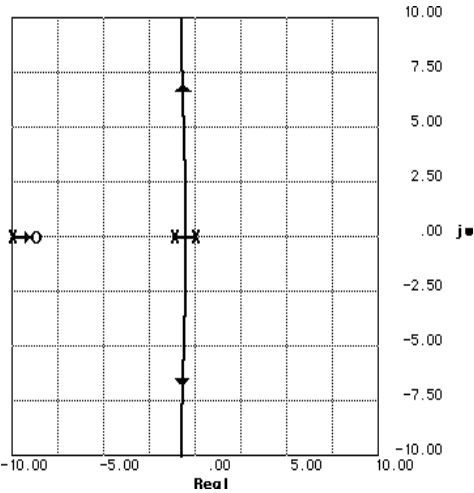

31. The design point is  $-0.506 \pm j1.0047$ . Excluding the pole at  $-\alpha$ , the sum of angles to the design point is  $-141.37^\circ$ . Thus, the contribution of the pole at  $-\alpha$  is  $141.37 - 180 = -38.63^\circ$ . The following geometry applies:

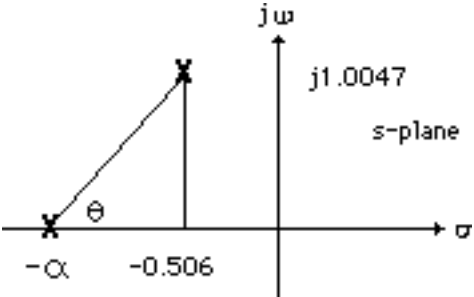

Hence,  $\tan \theta = \frac{1.0047}{\alpha - 0.506} = \tan 38.63 = 0.799$ . Thus  $\alpha = 1.763$ . Adding this pole at  $-1.763$  yields  $180^\circ$  at  $-0.506 \pm j1.0047$  with  $K = 7.987$ .

32.

a.

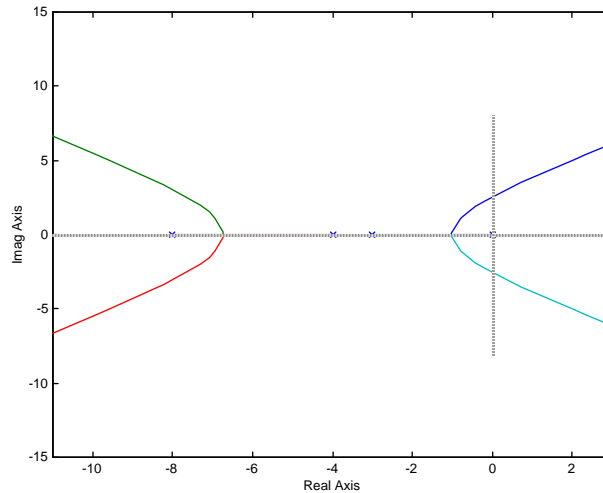

b. Searching along the 10% overshoot line (angle =  $126.239^\circ$ ), the point  $-0.7989 + j1.0898$  yields  $180^\circ$  for  $K = 81.74$ .

c. Higher-order poles are located at approximately  $-6.318$  and  $-7.084$ . Since these poles are more than 5 times further from the imaginary axis than the dominant pole found in (b), the second-order approximation is valid.

d. Searching along the imaginary axis yields  $180^\circ$  at  $j2.53$ , with  $K = 394.2$ .

Hence, for stability,  $0 < K < 394.2$ .

33.

**Program:**

```
pos=10;
z=-log(pos/100)/sqrt(pi^2+[log(pos/100)]^2)
numg=1;
deng=poly([0 -3 -4 -8]);
G=tf(numg,deng)
Gzpk=zpk(G)
rlocus(G,0:1:100)
pause
axis([-2,0,-2,2])
sgrid(z,0)
pause
[K,P]=rlocfind(G)
T=feedback(K*G,1)
pause
step(T)
```

**Computer response:**

z =

0.5912

Transfer function:

$$\frac{1}{s^4 + 15s^3 + 68s^2 + 96s}$$

Zero/pole/gain:

$$\frac{1}{s(s+8)(s+4)(s+3)}$$

Select a point in the graphics window

selected\_point =

$$-0.7994 + 1.0802i$$

K =

$$81.0240$$

P =

$$\begin{aligned} & -7.1058 \\ & -6.2895 \\ & -0.8023 + 1.0813i \\ & -0.8023 - 1.0813i \end{aligned}$$

Transfer function:

$$\frac{81.02}{s^4 + 15s^3 + 68s^2 + 96s + 81.02}$$

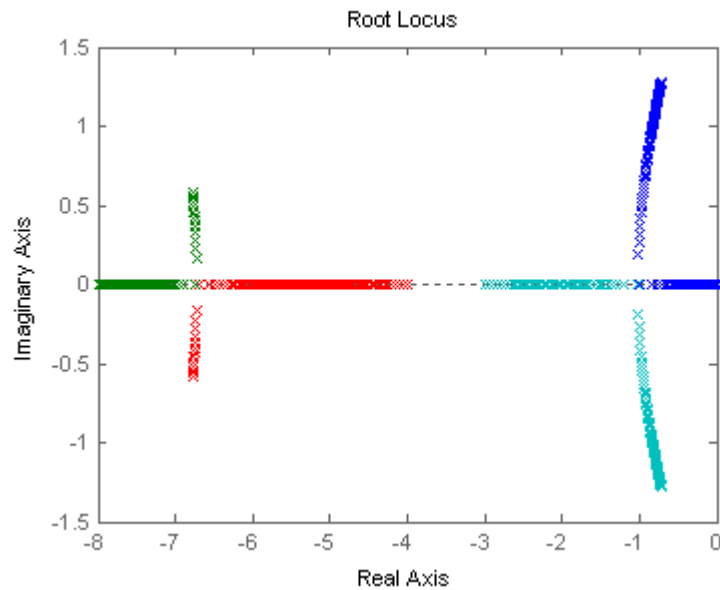

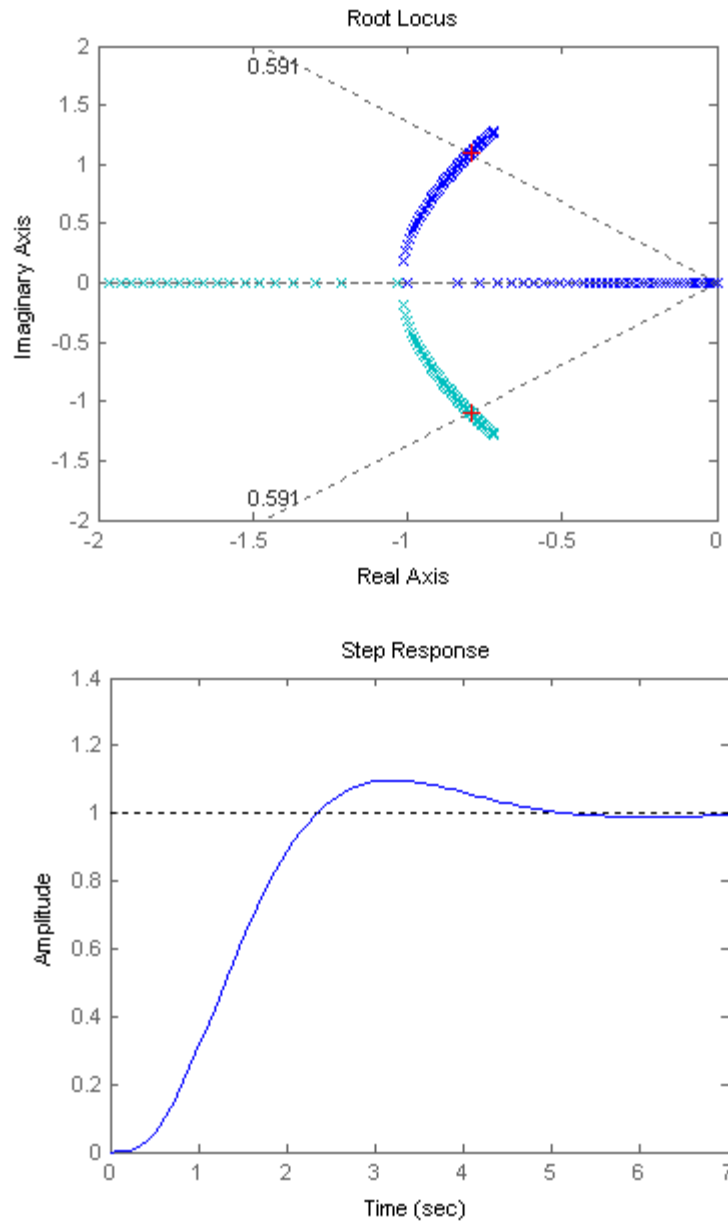

34. a. For a peak time of 1s, search along the horizontal line,  $\text{Im} = \pi / T_p = \pi$ , to find the point of intersection with the root locus. The intersection occurs at  $-2 \pm j\pi$  at a gain of 11.

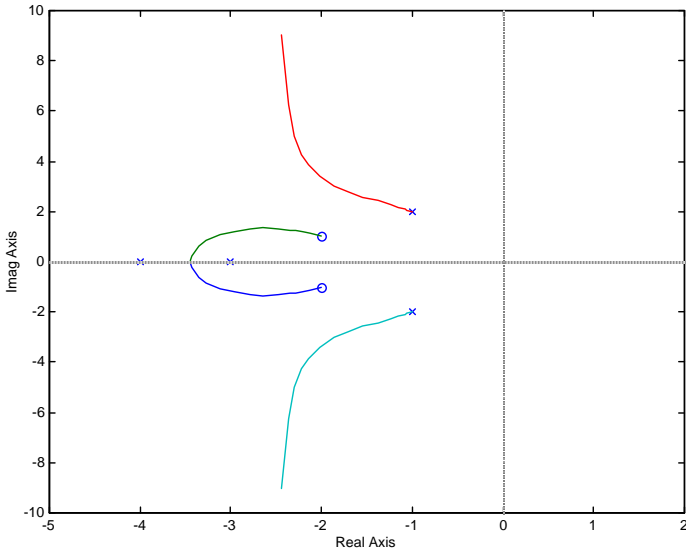

```
b.  
Program:  
numg=11*[1 4 5];  
deng=conv([1 2 5],poly([-3 -4]));  
G=tf(numg,deng);  
T=feedback(G,1);  
step(T)
```

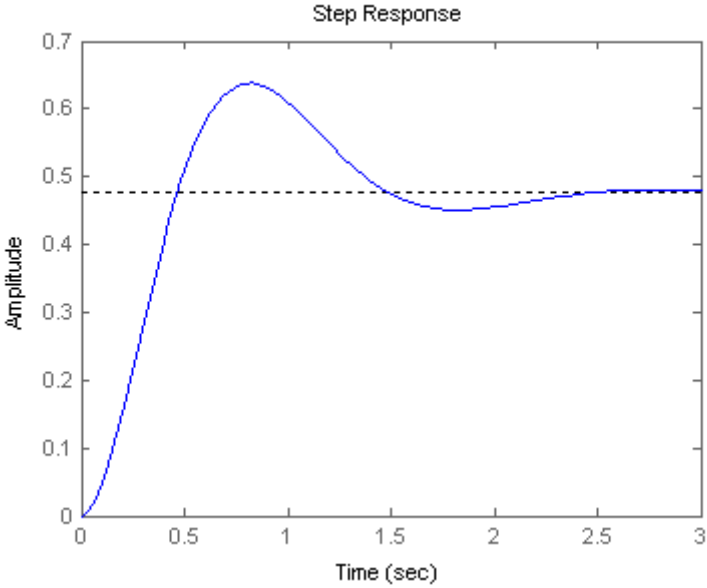

Peak time approximately 0.8 second instead of 1 second.

35.  
a.

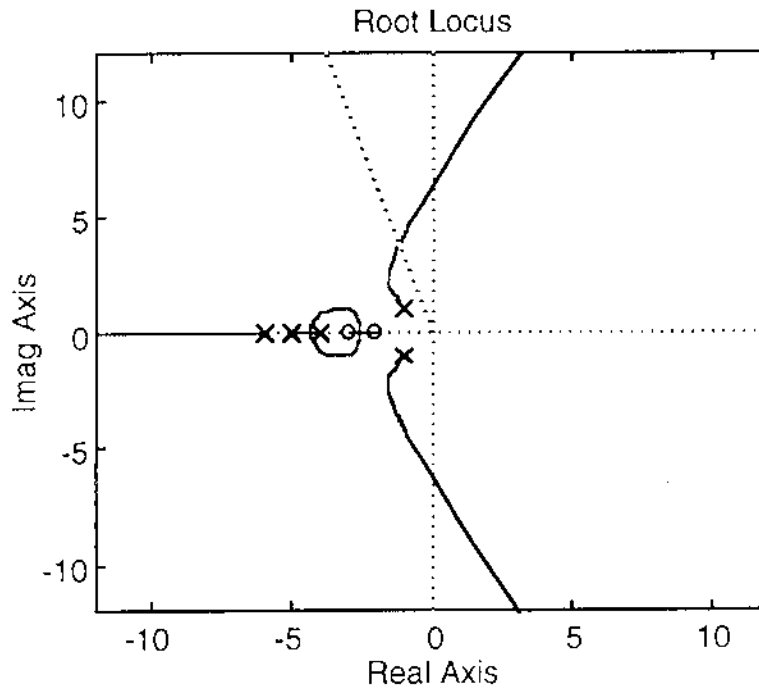

- b. Searching the  $j\omega$  axis for  $180^\circ$ , we locate the point  $j6.29$  at a gain of 447.83.  
 c. Searching for maximum gain between  $-4$  and  $-5$  yields the breakaway point,  $-4.36$ . Searching for minimum gain between  $-2$  and  $-3$  yields the break-in point,  $-2.56$ .  
 d.

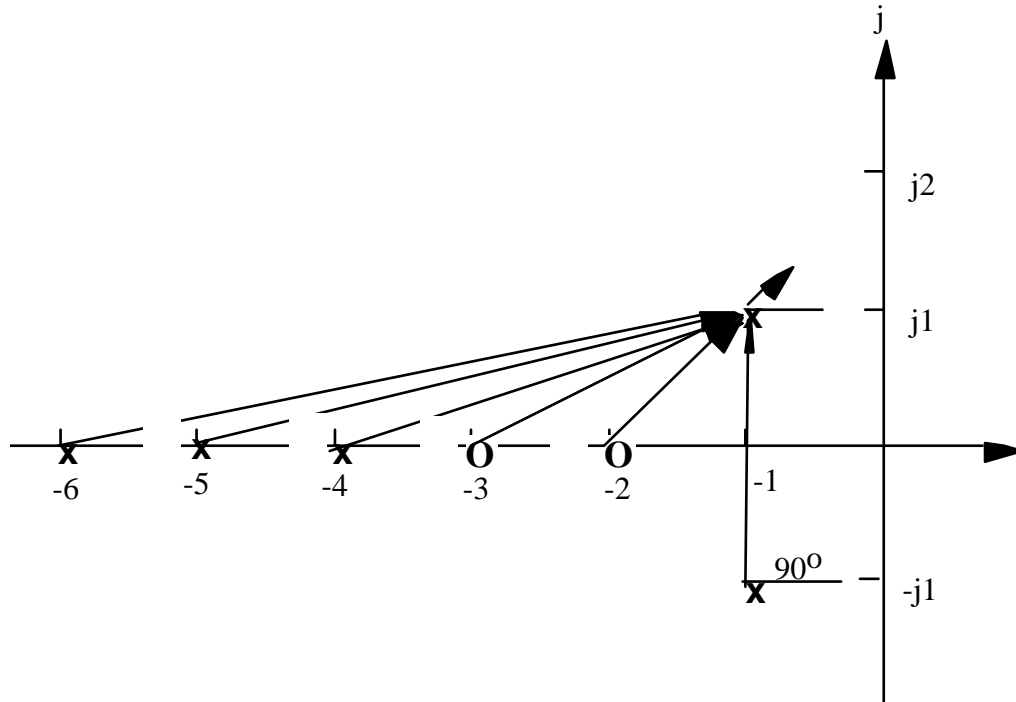

To find the angle of departure from the poles at  $-1 \pm j1$ :  $-\theta_1 - \theta_2 - \theta_3 + \theta_4 + \theta_5 - \theta_6 - 90^\circ$   
 $= -\tan^{-1}(1/5) - \tan^{-1}(1/4) - \tan^{-1}(1/3) + \tan^{-1}(1/2) + \tan^{-1}(1/1) - \theta_6 - 90^\circ = 180^\circ$ . Thus,  $\theta_6 = -242.22^\circ$

e. Searching along the  $\zeta = 0.3$  line ( $\theta = 180 - \cos^{-1}(\zeta) = 107.458^\circ$ ) for  $180^\circ$  we locate the point  $3.96 \angle 107.458^\circ = -1.188 \pm j3.777$ . The gain is 127.133.

36.

a.

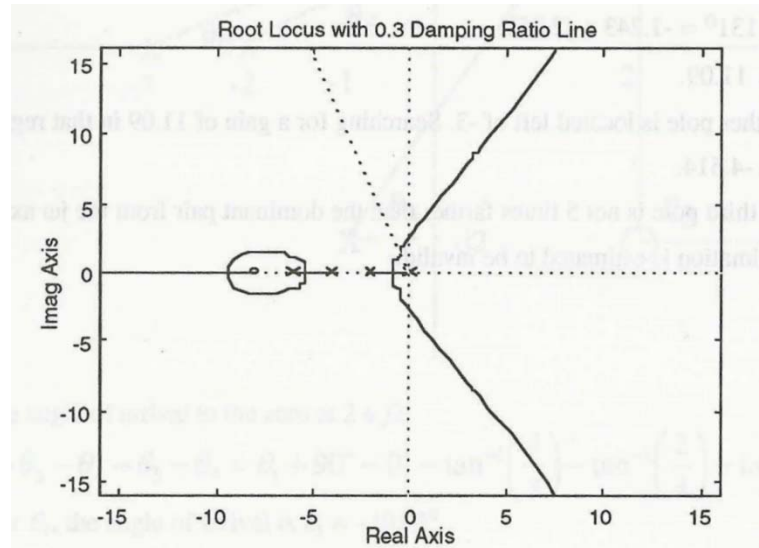

b. Searching the  $j\omega$  axis for  $180^\circ$ , we locate the point  $j2.56$  at a gain of 30.686.

c. Searching for maximum gain between 0 and -2 yields the breakaway point, -0.823. Searching for maximum gain between -4 and -6 yields the breakaway point, -5.37. Searching for minimum gain beyond -8 yields the break-in point, -9.39.

e. Searching along the  $\zeta = 0.3$  line ( $\theta = 180 - \cos^{-1}(\zeta) = 107.458^\circ$ ) for  $180^\circ$  we locate the point  $1.6 \angle 107.458^\circ = -0.48 \pm j1.53$ . The gain is 9.866.

37.

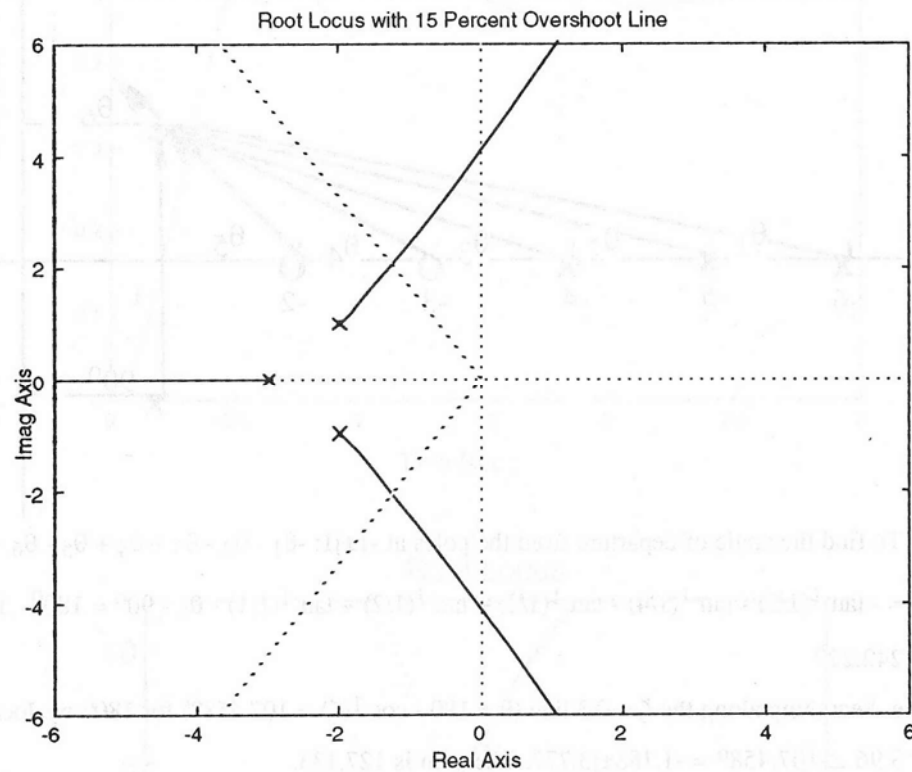

- a. Searching the 15% overshoot line ( $\zeta = 0.517$ ;  $\theta = 121.131^\circ$ ) for  $180^\circ$ , we find the point  $2.404 \angle 121.131^\circ = -1.243 + j2.058$ .
- b.  $K = 11.09$ .
- c. Another pole is located left of -3. Searching for a gain of 11.09 in that region, we find the third pole at -4.514.
- d. The third pole is not 5 times farther than the dominant pair from the  $j\omega$  axis. the second-order approximation is estimated to be invalid.



38.  
a.

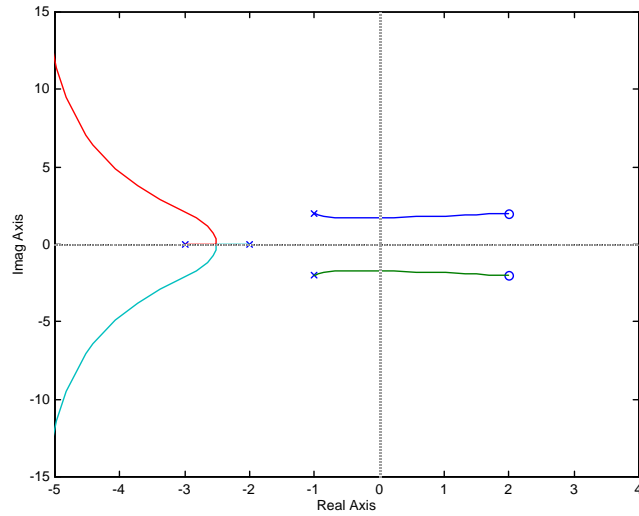

- b. Searching the  $j\omega$  axis for  $180^\circ$ , we locate the point  $j1.69$  at a gain of 4.249.  
 c. Searching between -2 and -3 for maximum gain, the breakaway is found at -2.512.  
 d.

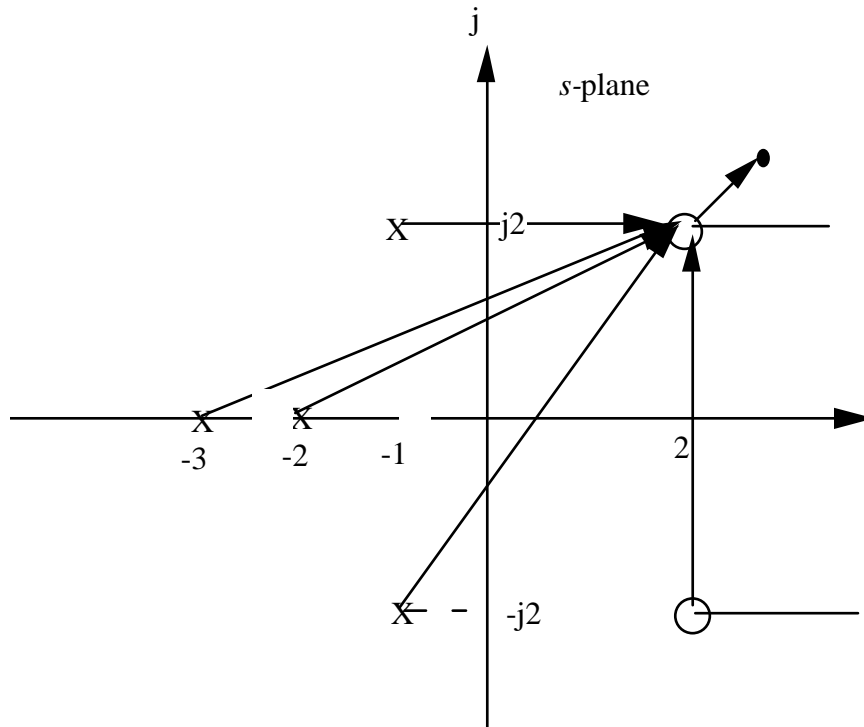

To find the angle of arrival to the zero at  $2 + j2$ :

$$1 \quad 2 \quad 3 \quad 4 \quad 5 \quad 6 \quad 1 \quad 90^\circ \quad 0^\circ \quad \tan^{-1} \frac{4}{3} \quad \tan^{-1} \frac{2}{4} \quad \tan^{-1} \frac{2}{5} \quad 180^\circ$$

Solving for  $\theta_1$ , the angle of arrival is  $\theta_1 = -191.5^\circ$ .

e. The closed-loop zeros are the poles of  $H(s)$ , or  $-1 \pm j2$ .

f. Searching the  $\zeta = 0.358$ ; ( $\theta = 110.97^\circ$ ) for  $180^\circ$ , we find the point

$= -0.6537 + j1.705$ . The gain,  $K = 0.8764$ .

g. Higher-order poles are at  $-2.846 \pm j1.731$ . These are not 5 times further than the dominant poles.

Further, there are closed-loop zeros at  $-1 \pm j2$  that are not cancelled any higher-order poles. Thus, the second-order approximation is not valid.

39.

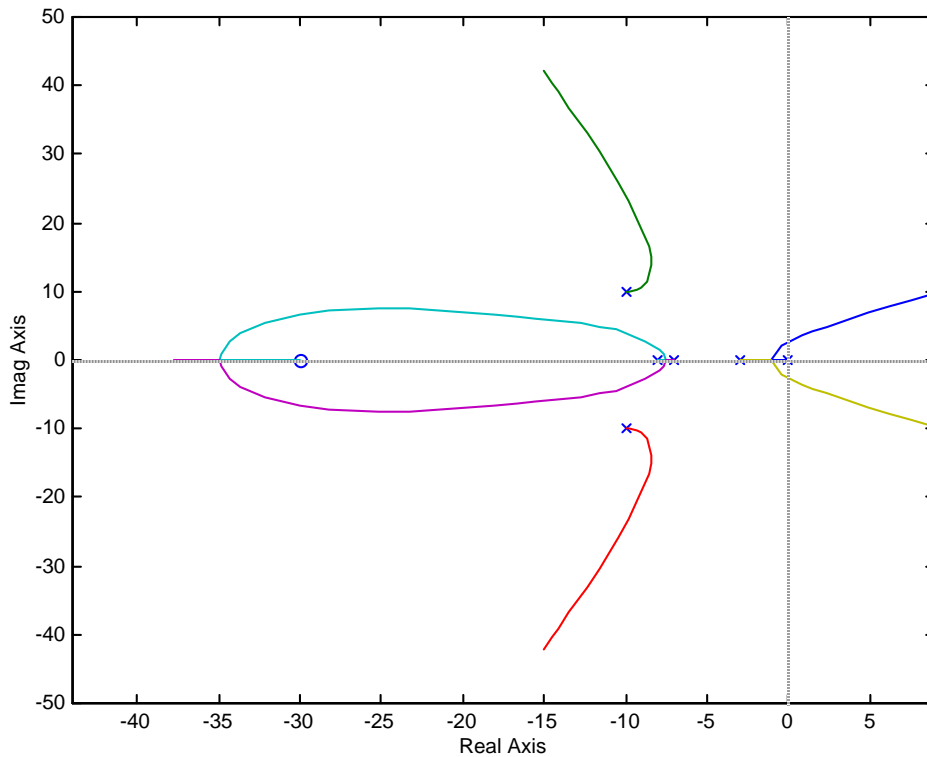

a. The root locus crosses the imaginary axis at  $j2.621$  with  $K = 4365$ . Therefore, the system is stable for  $0 < K < 4365$ .

b. Search the 0.707 damping ratio line for  $180^\circ$  and find  $-0.949 + j0.949$  with  $K = 827.2$ .

c. Assume critical damping where root locus breaks away from the real axis. Locus breaks away at  $-1.104$  with  $K = 527.6$ .

40.

**Program:**

```
numg=1;
deng=poly([0 -3 -7 -8]);
```

```

numh=[1 30];
denh=[1 20 200];
G=tf(numg,deng)
Gzpk=zpk(G)
H=tf(numh,denh)
rlocus(G*H)
pause
K=0:10:1e4;
rlocus(G*H,K)
sgrid(0.707,0)
axis([-2,2,-5,5]);
pause
for i=1:1:3;
[K,P]=rlocfind(G*H)
end
T=feedback(K*G,H)
step(T)

```

**Computer response:**

Transfer function:

$$\frac{1}{s^4 + 18 s^3 + 101 s^2 + 168 s}$$

Zero/pole/gain:

$$\frac{1}{s (s+8) (s+7) (s+3)}$$

Transfer function:

$$\frac{s + 30}{s^2 + 20 s + 200}$$

Select a point in the graphics window

```

selected_point =
    -0.9450 + 0.9499i

```

K =

$$828.1474$$

P =

```

-9.9500 +10.0085i
-9.9500 -10.0085i
-8.1007 + 1.8579i
-8.1007 - 1.8579i
-0.9492 + 0.9512i
-0.9492 - 0.9512i

```

Select a point in the graphics window

```

selected_point =
    0.0103 + 2.6385i

```

8-38 Chapter 8: Root Locus Techniques

K =

4.4369e+003

P =

-9.7320 +10.0691i  
-9.7320 -10.0691i  
-9.2805 + 3.3915i  
-9.2805 - 3.3915i  
0.0126 + 2.6367i  
0.0126 - 2.6367i

Select a point in the graphics window

selected\_point =

-1.0962 - 0.0000i

K =

527.5969

P =

-9.9682 +10.0052i  
-9.9682 -10.0052i  
-7.9286 + 1.5303i  
-7.9286 - 1.5303i  
-1.1101  
-1.0962

Transfer function:

$$\frac{527.6 s^2 + 1.055e004 s + 1.055e005}{s^6 + 38 s^5 + 661 s^4 + 5788 s^3 + 23560 s^2 + 3.413e004 s + 1.583e004}$$

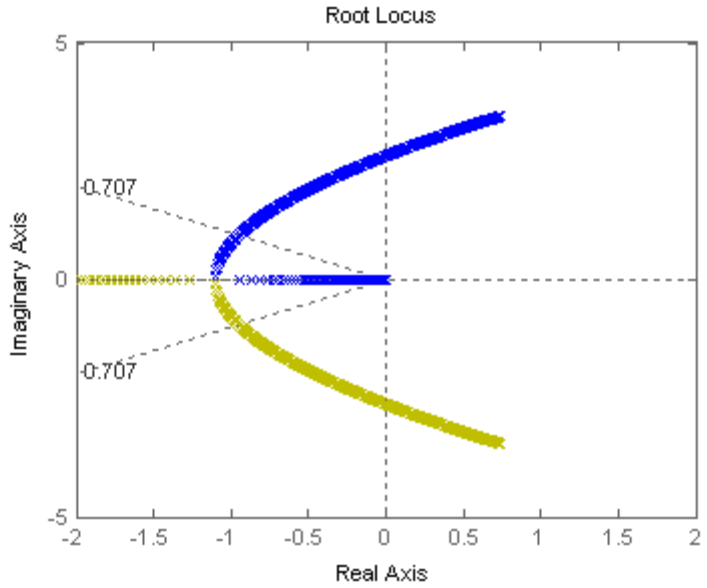
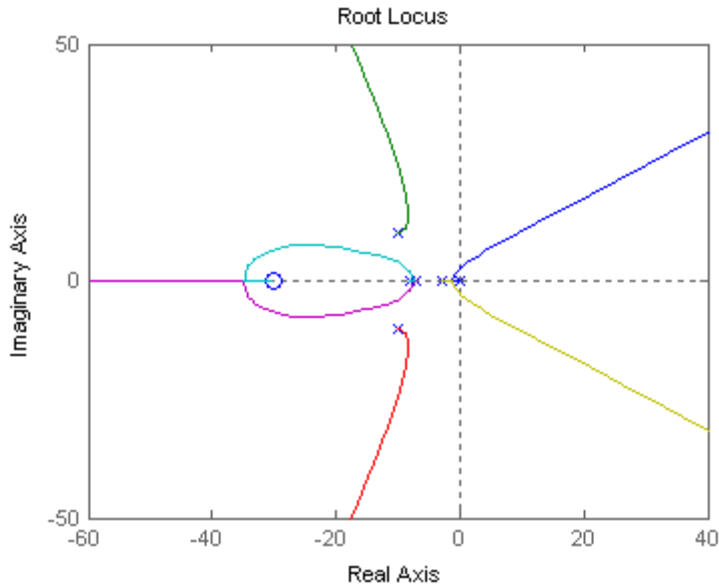

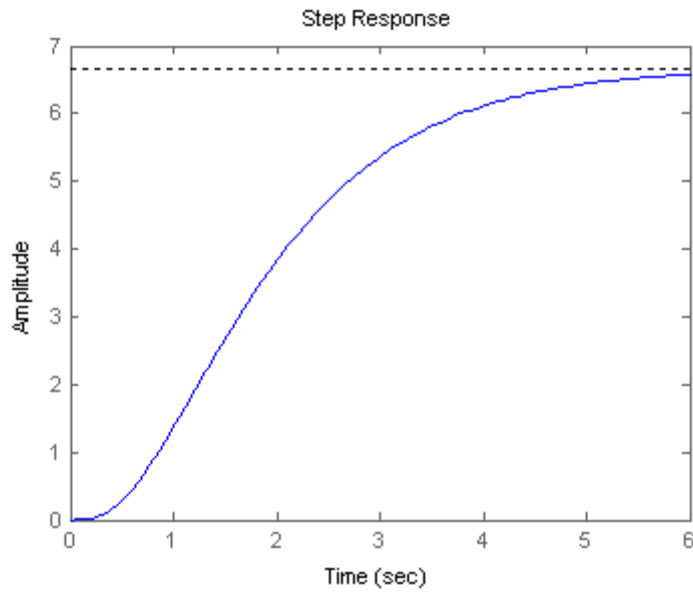

- 41.**
- a. Search  $j\omega = j10$  line for  $180^\circ$  and find  $-4.533 + j10$  with  $K = 219.676$ .
  - b.  $K_a = \frac{219.676 \times 6}{20}$
  - c. A settling time of 0.4 seconds yields a real part of -10. Thus if the zero is at the origin,  $G(s) = \frac{K}{s(s+20)}$ , which yields complex poles with -10 as the real part. At the design point,  $-10 + j10$ ,  $K = 200$ .
- 42.**
- a. Searching along  $\zeta\omega_n = -1$  for  $180^\circ$ , find  $-1 + j2.04$  with  $K = 170.13$ .
  - b. Assume critical damping when root locus breaks away from the real axis. Searching for maximum gain, the breakaway point is at -1.78 with  $K = 16.946$ .

- 43.**
- a. The characteristic equation is  $1 + \frac{K(s-1)}{(s+2)(s+3)} = 0$  or  $s^2 + (5+K)s + (6-K) = 0$

The Routh array is

$s^2$	1	$6 - K$
$s$	$5 + K$	
1	$6 - K$	

It follows that  $-5 < K < 6$

b. The locus for  $K > 0$  is

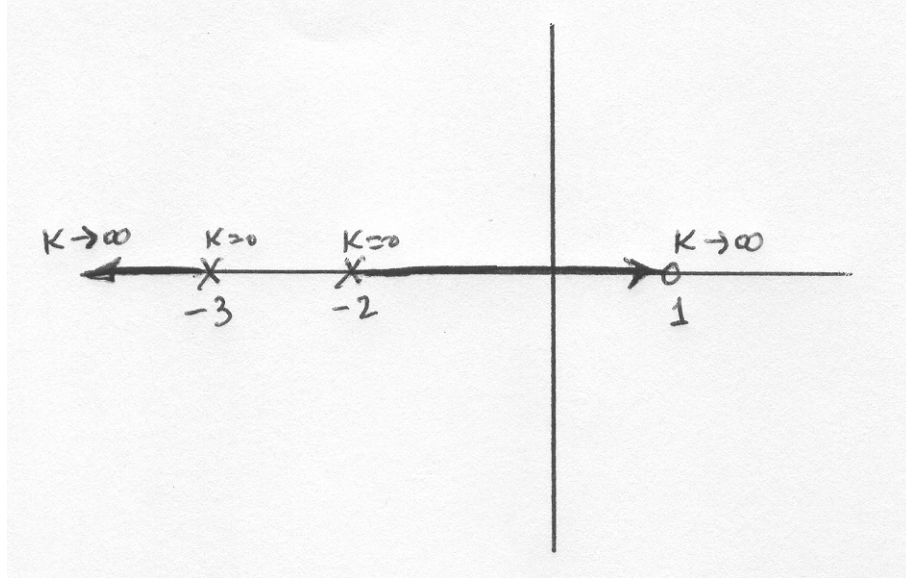

c. To find the break-in, breakaway points let  $K = \frac{(\sigma+1)(\sigma+2)}{\sigma-1} = \frac{\sigma^2 + 5\sigma + 6}{\sigma-1}$ . Then calculate  $\frac{dK}{d\sigma} = \frac{(\sigma-1)(2\sigma+5) - (\sigma^2 + 5\sigma + 6)}{(\sigma-1)^2} = \frac{\sigma^2 - 2\sigma - 11}{(\sigma-1)^2}$

The roots of the numerator are  $\sigma = -2.4641, 4.4641$

The locus for  $K < 0$  is

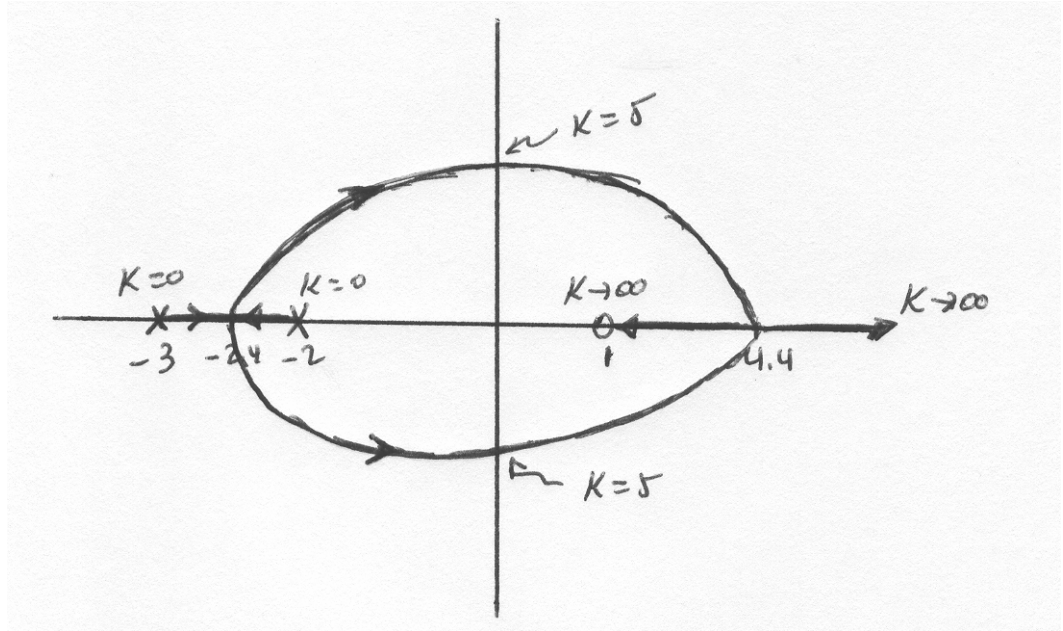

- d. The smallest settling time for the system will occur when both roots are as far away as possible to the left of the  $j\omega$  axis. This will happen when the system has identical roots at  $-2.4641$ . To find the value of  $K$  we use the characteristic equation

$$1 - \frac{K(s-1)}{(s+2)(s+3)} \Big|_{s=-2.4641} = 0. \text{ Solving for } K \text{ we get } K = -0.0718$$

e. The proportional error constant  $K_p = \lim_{s \rightarrow 0} \frac{K(s-1)}{(s+1)(s+2)} = -\frac{K}{6}$

$$\text{Then } e_{ss} = \frac{1}{1+K_p} = \frac{6}{6-K} = 0.9882$$

- f. The system in this case is critically damped, the settling time  $T_s \approx \frac{4}{2.4641} = 1.6 \text{ sec}$ . The step response will approximately be:



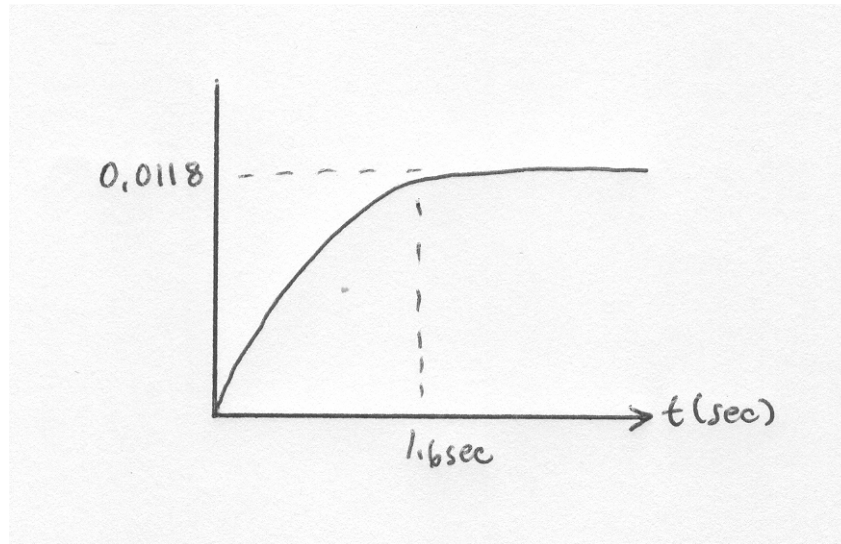

44.

$T(s) = \frac{K}{s^3 + 6s^2 + 5s + K}$ . Differentiating the characteristic equation,  $s^3 + 6s^2 + 5s + K = 0$ , yields,

$$3s^2 \frac{\delta s}{\delta K} + 12s \frac{\delta s}{\delta K} + 5 \frac{\delta s}{\delta K} + 1 = 0.$$

Solving for  $\frac{\delta s}{\delta K}$ ,

$$\frac{\delta s}{\delta K} = \frac{-1}{3s^2 + 12s + 5}$$

The sensitivity of  $s$  to  $K$  is

$$S_{s:K} = \frac{K}{s} \frac{\delta s}{\delta K} = \frac{K}{s} \frac{-1}{3s^2 + 12s + 5}$$

a. Search along the  $\zeta = 0.591$  line and find the root locus intersects at  $s = 0.7353 \angle 126.228^\circ = -0.435 + j0.593$  with  $K = 2.7741$ . Substituting  $s$  and  $K$  into  $S_{s:K}$  yields

$$S_{s:K} = 0.487 - j0.463 = 0.672 \angle -43.553^\circ$$

b. Search along the  $\zeta = 0.456$  line and find the root locus intersects at  $s = 0.8894 \angle 117.129^\circ = -0.406 + j0.792$  with  $K = 4.105$ . Substituting  $s$  and  $K$  into  $S_{s:K}$  yields

$$S_{s:K} = 0.482 - j0.358 = 0.6 \angle -36.603^\circ$$

c. Least sensitive:  $\zeta = 0.456$ .

45.

The sum of the feedback paths is  $H_e(s) = 1 + 0.02s + \frac{0.00076s^3}{s+0.06}$ . Thus,

$$H_e(s) = \frac{0.00076(s^3 + 26.316s^2 + 1317.4s + 78.947)}{s + 0.06}$$

and

$$G(s)H_e(s) = 0.00076 \frac{K(s^3 + 26.316s^2 + 1317.4s + 78.947)}{s(s + 0.06)(s^2 + 7s + 1220)}$$

$$G(s)H_e(s) = 0.00076 \frac{K([s + 0.06][(s + 13.128 + 33.815i)(s + 13.128 - 33.815i)])}{s(s + 0.06)(s^2 + 7s + 1220)}$$

$$G(s)H_e(s) = 0.00076 \frac{K([s + 13.128 + 33.815i][s + 13.128 - 33.815i])}{s([s + 3.5 + 34.753i][s + 3.5 - 34.753i])}$$

Plotting the root locus,

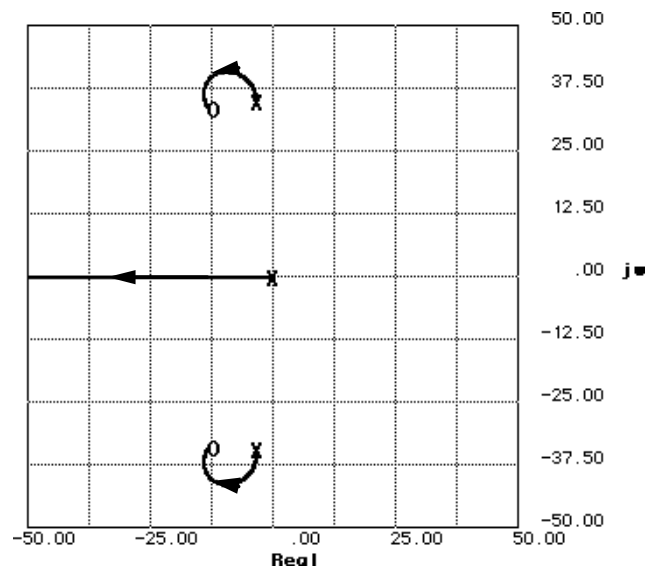

Searching vertical lines to calibrate the root locus, we find that  $0.00076K$  is approximately 49.03 at

$-10 \pm j41.085$ . Searching the real axis for  $0.00076K = 49.03$ , we find the third pole at  $-36.09$ .

a.  $\zeta = \cos(\tan^{-1}(\frac{41.085}{10})) = 0.236$

b.  $\%OS = e^{-\zeta/\sqrt{1-\zeta^2}} \times 100 = 46.63\%$

c.  $\omega_n = \sqrt{10^2 + 41.085^2} = 42.28 \text{ rad/s}$

d.  $T_s = \frac{4}{\zeta\omega_n} = \frac{4}{10} = 0.4 \text{ seconds}$

e.  $T_p = \frac{\pi}{\omega_n\sqrt{1-\zeta^2}} = \frac{\pi}{41.085} = 0.076 \text{ seconds}$

46.

Push  $K_2$  to the right past the summing junction and find,  $T(s) = (1 + \frac{K_1 s}{K_2}) (\frac{K_2}{s^2 + K_3 s + K_2})$

$$= \frac{K_1 (s + \frac{K_2}{K_1})}{s^2 + K_3 s + K_2} \cdot \text{Changing form, } T(s) = \frac{K_1 (s + \frac{K_2}{K_1})}{1 + \frac{K_3 s}{s^2 + K_2}} \cdot \text{Thus, } G(s)H(s) = \frac{K_3 s}{s^2 + K_2} \cdot \text{Sketching the}$$

root locus,

a.

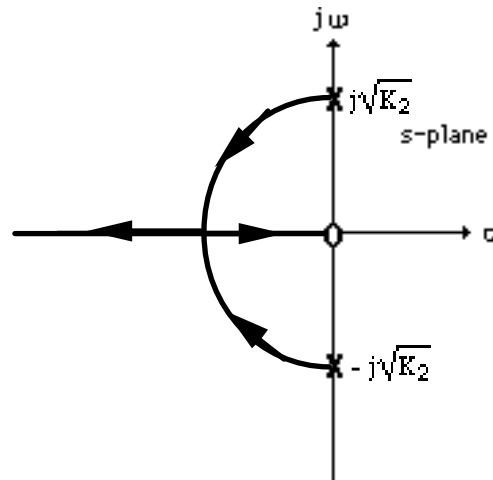

$$\text{b. } T(s) = \frac{K_1 (s + \frac{K_2}{K_1})}{s^2 + K_2} = \frac{K_1 (s + \frac{K_2}{K_1})}{1 + \frac{K_3 s}{s^2 + K_2}} \cdot \text{Therefore closed-loop zero at } -\frac{K_2}{K_1} \cdot \text{Notice that the zero}$$

at the origin of the root locus is not a closed-loop zero.

c. Push  $K_2$  to the right past the summing junction and find,  $T(s) = (1 + \frac{K_1 s}{K_2}) (\frac{K_2}{s^2 + K_3 s + K_2})$

$$= \frac{K_1 (s + \frac{K_2}{K_1})}{s^2 + K_3 s + K_2} \cdot \text{Changing form, } T(s) = \frac{K_1 (s + \frac{K_2}{K_1})}{s^2 + K_3 s} \cdot \text{Thus, } G(s)H(s) = \frac{K_2}{s^2 + K_3 s} \cdot \text{Sketching the}$$

root locus,

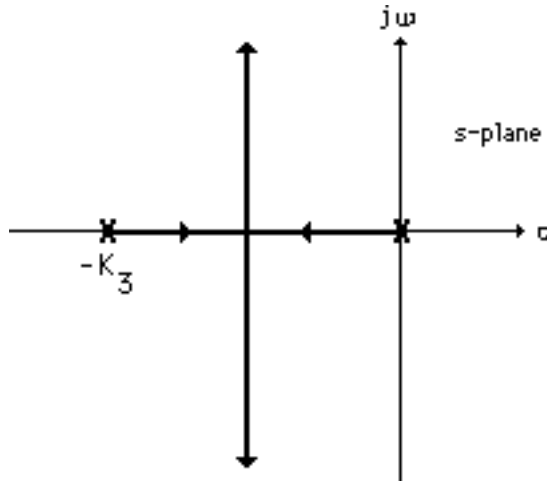

The closed-loop zero is at  $-\frac{K_2}{K_1}$ .

47.

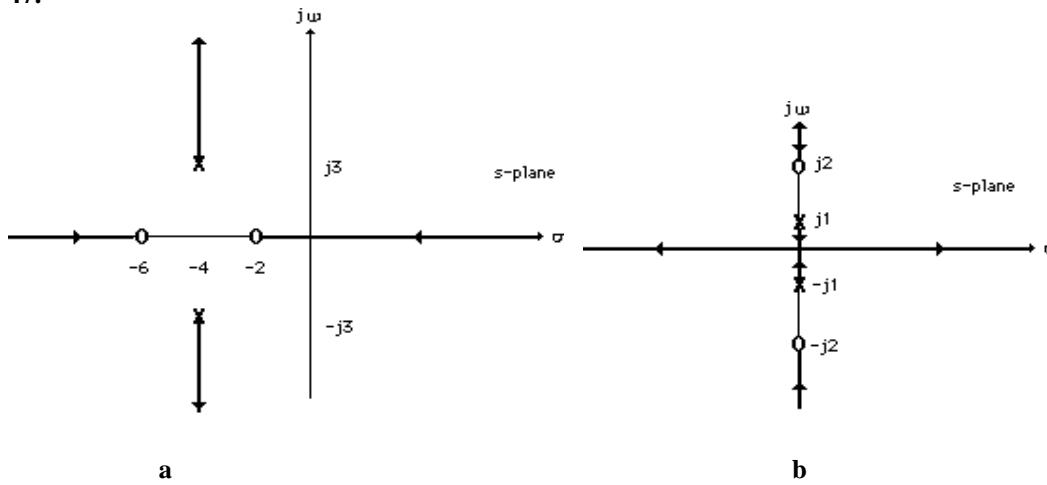

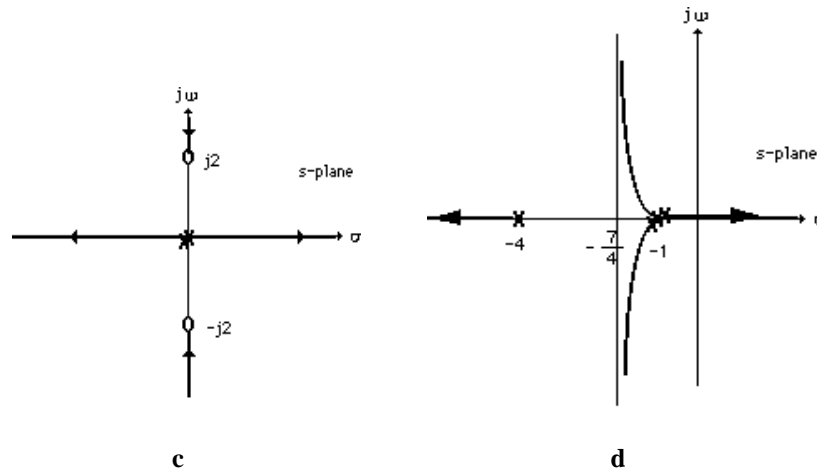

48.

a. Using Figure P8.15(a),

$$[Ms^2+(D+D_C)s+(K+K_C)]X(s) - [D_Cs+K_C]X_a(s) = 0$$

Rearranging,

$$[Ms^2+Ds+K]X(s) = -[D_Cs+K_C](X(s)-X_a(s)) \quad (1)$$

where  $[D_Cs+K_C](X(s)-X_a(s))$  can be thought of as the input to the plant.

For the active absorber,

$$(M_Cs^2+D_Cs+K_C)X_a(s) - (D_Cs+K_C)X(s) = 0$$

or

$$M_Cs^2X_a(s)+D_Cs(X_a(s)-X(s))+K_C(X_a(s)-X(s)) = 0$$

Adding  $-M_Cs^2X(s)$  to both sides,

$$M_Cs^2(X_a(s)-X(s))+D_Cs(X_a(s)-X(s))+K_C(X_a(s)-X(s)) = -M_Cs^2X(s)$$

Let  $X_a(s)-X(s) = X_C(s)$  and  $s^2X(s) = C(s) =$  plant output acceleration. Therefore,

$$M_Cs^2X_C(s)+D_CsX_C(s)+K_CX_C(s) = -M_CC(s)$$

or

$$(M_Cs^2+D_Cs+K_C)X_C(s) = -M_CC(s) \quad (2)$$

Using Eqs. (1) and (2), and  $X_a(s)-X(s) = X_C(s)$ ,

$$\frac{X_C(s)}{C(s)} = \frac{-M_C}{M_Cs^2+D_Cs+K_C} ; \frac{X(s)}{X_C(s)} = \frac{D_Cs+K_C}{Ms^2+Ds+K}$$

which suggests the following block diagram:

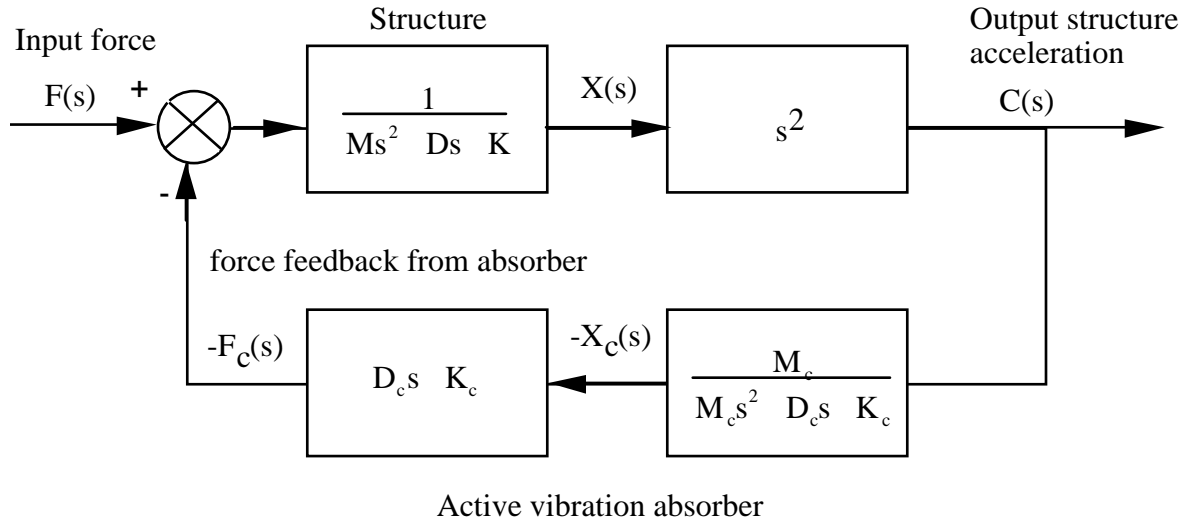

b. Substituting  $M = D = K = D_c = K_c = 1$  and redrawing the block diagram above to show  $X(s)$  as the output yields a block diagram with  $G(s) = \frac{1}{s^2 + s + 1}$  and  $H(s) = \frac{M_c s^2 (s + 1)}{M_c s^2 + s + 1}$ . To study the steady-

state error, we create a unity-feedback system by subtracting unity from  $H(s)$ . Thus  $H_e(s) = H(s) - 1 = \frac{(M_c s^3 - s - 1)}{M_c s^2 + s + 1}$ . The equivalent  $G(s)$  for this unity-feedback system is  $G_e(s) = \frac{G}{1 + G H_e} = \frac{1}{M_c s^2 + s + 1} \cdot \frac{M_c s^2 + s + 1}{M_c s^4 + 2 M_c s^3 + s^3 + M_c s^2 + 2 s^2 + s}$ . Hence the equivalent unity-feedback system is Type 1 and will

respond with zero steady-state error for a step force input.

c. Using  $G_e(s)$  in part b, we find  $T(s) = \frac{G_e}{1 + G_e} = \frac{M_c s^2 + s + 1}{(s^2 + 2 s + 2) M_c s^2 + s^3 + 2 s^2 + 2 s + 1}$ . Dividing

numerator and denominator by  $s^3 + 2 s^2 + 2 s + 1$ ,  $T(s) = \frac{\frac{M_c s^2 + s + 1}{s^3 + 2 s^2 + 2 s + 1}}{\frac{(s^2 + 2 s + 2) M_c s^2}{s^3 + 2 s^2 + 2 s + 1} + 1}$ . Thus, the system

has the same root locus as a system with  $G(s)H(s) = \frac{(s^2 + 2 s + 2) M_c s^2}{s^3 + 2 s^2 + 2 s + 1} = \frac{(s^2 + 2 s + 2) M_c s^2}{(s + 1)(s^2 + s + 1)}$ .

Sketching the root locus,

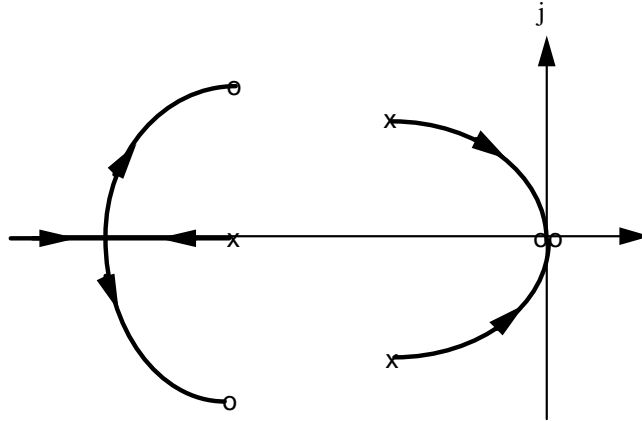

49.

a. The open loop transmission is  $L(s) = \frac{1300K}{s^2 - 739600}$ .

There are two asymptotes with  $\sigma_a = \frac{-860 + 860}{2 - 0} = 0$  and angles  $\theta_a = \frac{\pi}{2}, \frac{3\pi}{2}$

To find the breakaway points let  $K = -\frac{\sigma^2 - 860^2}{1300}$ . Then  $\frac{dK}{d\sigma} = -\frac{2\sigma}{1300} = 0$ , so the

breakaway points occur when  $\sigma = 0$ . The gain at this point is given by the solution of

$$1 + \frac{1300K}{s^2 - 860^2} \Big|_{s=0} = 0 \text{ or } K = 568.9$$

It is obvious from the figure that the system is unstable for all values of  $K > 0$ .

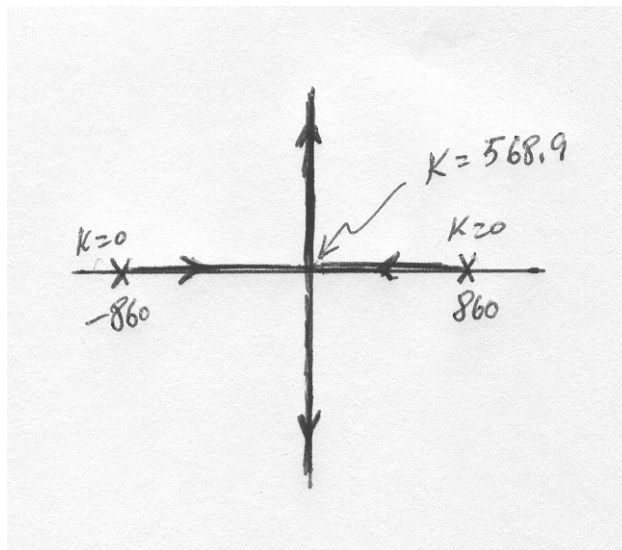

b. The open loop transmission is  $L(s) = \frac{1300K(s + 200)}{(s + 1000)(s^2 - 739600)}$ .

There are two asymptotes with  $\sigma_a = \frac{-1000 - 860 + 860 - (-200)}{3 - 1} = -400$  and angles

$$\theta_a = \frac{\pi}{2}, \frac{3\pi}{2}$$

To find the breakaway points let

$$K = -\frac{(\sigma + 1000)(\sigma^2 - 860^2)}{1300(\sigma + 200)} = -\frac{\sigma^3 + 1000\sigma^2 - 739.6 \times 10^3 \sigma - 739.6 \times 10^6}{1300(\sigma + 200)}$$

Then  $\frac{dK}{d\sigma} = -\frac{2\sigma^3 + 1600\sigma^2 + 400 \times 10^3 \sigma + 591.68 \times 10^6}{1300(\sigma + 200)} = 0$  The numerator has two

complex conjugate solutions, and a real  $\sigma = -928$ . The gain at this point is given by the solution

$$\text{of } 1 + \frac{1300K(s + 200)}{(s + 1000)(s^2 - 860^2)} \Big|_{s=-928} = 0 \text{ or } K = 9.25$$

We use Routh-Hurwitz to find the range of  $K$  for which the system is closed loop stable. Let

$$1 + \frac{1300K(s + 200)}{(s + 1000)(s^2 - 860^2)} = 0 \text{ or}$$

$$s^3 + 1000s^2 + (1300K - 739600)s + (260000K - 739.6 \times 10^6) = 0$$

The Routh array is:

$s^3$	1	$1300K - 739600$
$s^2$	1000	$260000K - 739.6 \times 10^6$
$s$	$1040K$	
1	$260000K - 739.6 \times 10^6$	

The dominant requirement given by the fourth row:  $K > 2844.6$



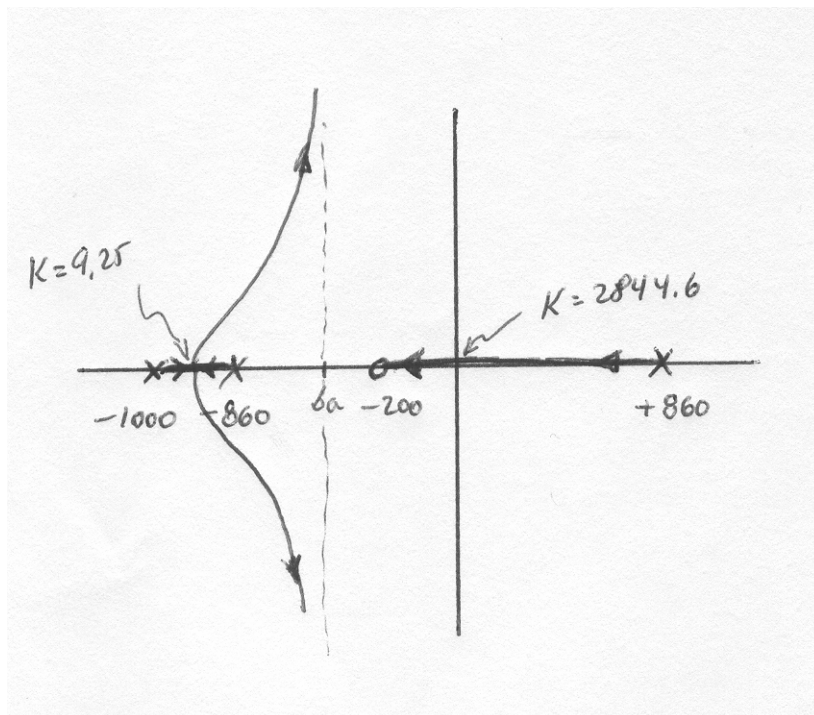

50.

a. After substituting numerical values  $G(s) = \frac{\phi}{\delta}(s) = 0.5V \frac{s + \frac{V}{0.6}}{s^2 - 12.25}$

The system's characteristic equation is:

$$1 + 0.5V \frac{s + \frac{V}{0.6}}{s^2 - 12.25} = 0 \text{ or } s^2 + 0.5Vs + (0.833V^2 - 12.25) = 0$$

The Routh array is

$s^2$	1	$0.833V^2 - 12.25$
$s$	$0.5V$	
1	$0.833V^2 - 12.25$	

From which we get  $V > 3.83 \frac{m}{s}$

b. The characteristic equation cannot be written in the form  $1 + VG_{eq}(s) = 0$

c. Solving for the two roots we get  $s_{1,2} = \frac{-0.5 \pm \sqrt{-3.08V^2 + 49}}{2}$

A simple script that will plot the root locus is

```

>> v=linspace(0,4,100000);
>> s1 = (-0.5+sqrt(-3.08*v.^2+49))/2;
>> s2 = (-0.5-sqrt(-3.08*v.^2+49))/2;
>> plot(real(s1),imag(s1),real(s2),imag(s2))

```

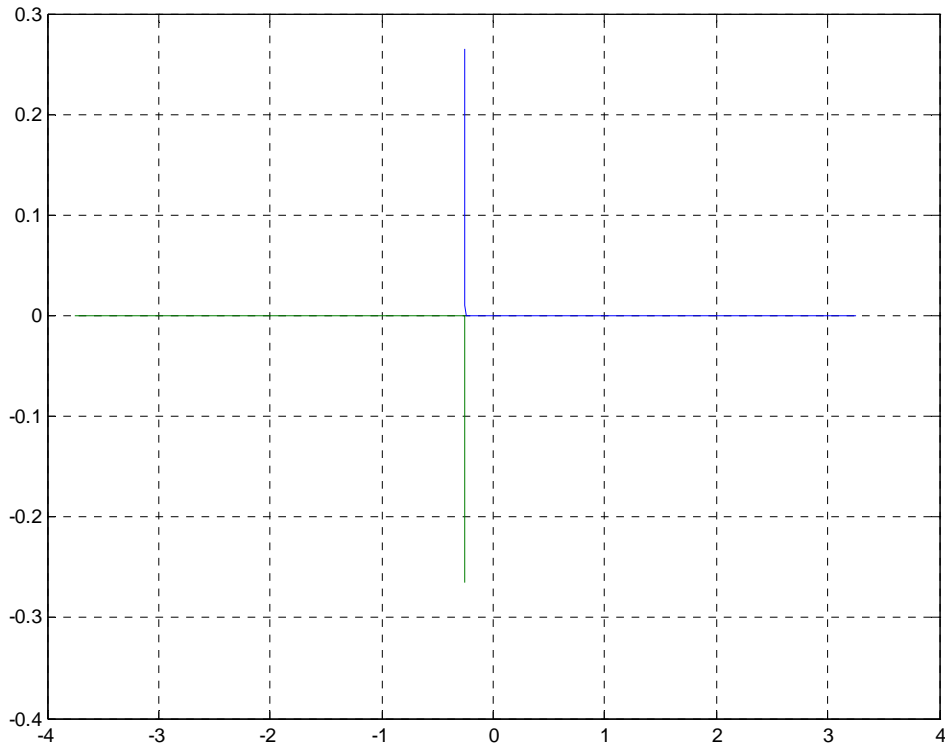

51.

a. The system's characteristic equation is found by calculating  $\det(s\mathbf{I} - \mathbf{A}) = 0$ . This results in

$$s^4 - 12.3415s^3 + (54.5414K - 256.9538)s^2 + 1250.2Ks - 1995.2K = 0$$

Which can be manipulated into

$$1 + K \frac{54.5414s^2 + 1250.2s - 1995.2}{s^4 - 12.3415s^3 - 256.9538s^2} = 0 \quad \text{or} \quad 1 + K \frac{54.5414(s - 1.498)(s + 24.42)}{s^2(s + 11)(s - 23.3472)} = 0$$

b. There are two asymptotes with  $\theta_a = \frac{\pi}{2}, \frac{3\pi}{2}$  and real axis intersection

$$\sigma_a = \frac{0+0-11+23.3472-1.498+24.42}{4-2} = 17.63.$$

To find the break in-breakaway points let

$$K = -\frac{\sigma^4 - 12.3415\sigma^3 - 256.9538\sigma^2}{54.5414\sigma^2 + 1250.2\sigma - 1995.2}, \text{ then}$$

$$\begin{aligned} \frac{dK}{d\sigma} &= -\frac{(54.5414\sigma^2 + 1250.2\sigma - 1995.2)(4\sigma^3 - 37.0245\sigma^2 - 513.91\sigma)}{(54.5414\sigma^2 + 1250.2\sigma - 1995.2)^2} \\ &\quad - \frac{(\sigma^4 - 12.3415\sigma^3 - 256.9538\sigma^2)(109.0828\sigma + 1250.2)}{(54.5414\sigma^2 + 1250.2\sigma - 1995.2)^2} \\ &= -\frac{109.0828\sigma^5 + 3077.5\sigma^4 - 38840\sigma^3 - 247380\sigma^2 + 1025400\sigma}{(54.5414\sigma^2 + 1250.2\sigma - 1995.2)^2} \end{aligned}$$

The numerator of this expression has roots at  $\sigma = 0, -36.13, 11.95, -7.1, 3.0664$

The root locus is:

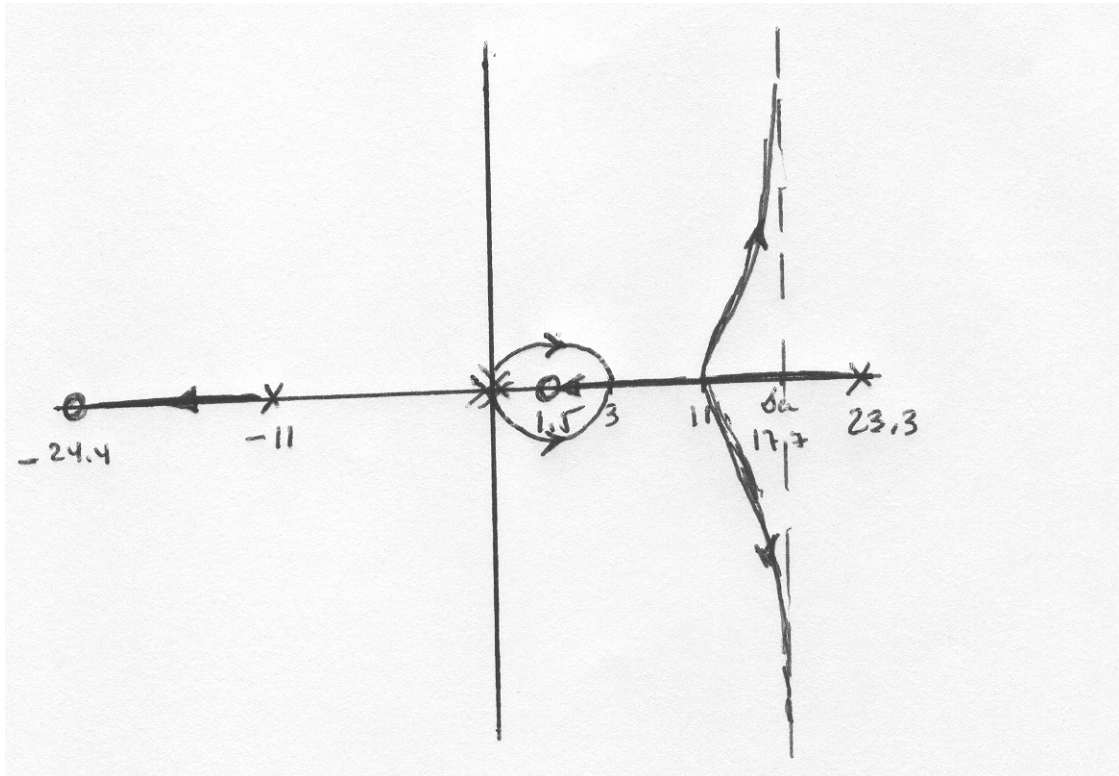

c. For any value of  $K > 0$  there are always closed loop poles in the RHP.

52.

a. The open loop transmission is  $G(s) = (K_p + \frac{K_I}{s}) \frac{1}{Vs} = \frac{K_p s + K_I}{Vs^2}$ . The characteristic equation is  $1 + \frac{K_p s + K_I}{Vs^2} = 0$  or  $Vs^2 + K_p s + K_I = 0$ . If  $K_p$  is considered variable, then this equation can be written as  $1 + \frac{K_p}{V} \frac{s}{s^2 + \frac{K_I}{V}} = 0$ . In this case there is one asymptote. The break-in

point is found by writing  $K_p = -\frac{V\sigma^2 + K_I}{\sigma}$  and computing

$$\frac{dK_p}{d\sigma} = -\frac{\sigma(2V\sigma) - (V\sigma^2 + K_I)}{\sigma^2} = -\frac{V\sigma^2 - K_I}{\sigma^2}. \text{ The numerator has roots at } \sigma = \pm\sqrt{\frac{K_I}{V}}.$$

The root locus is:

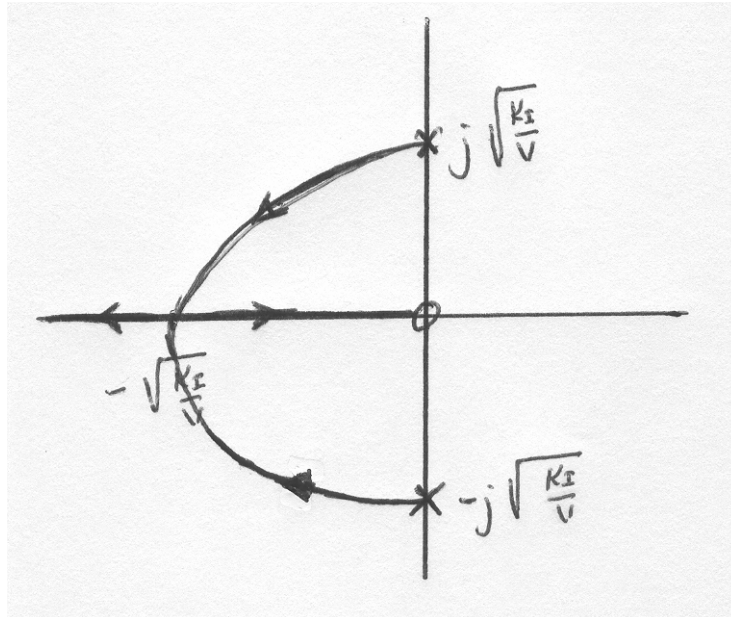

b. The characteristic equation can now be written as  $1 + \frac{K_I}{V} \frac{1}{s(s + \frac{K_p}{V})} = 0$ . There are now two

asymptotes with angles  $\theta_a = \frac{\pi}{2}, \frac{3\pi}{2}$  and real axis intersection  $\sigma_a = \frac{0 - \frac{K_p}{V}}{2 - 0} = -\frac{K_p}{2V}$ . The

break-in breakaway point can be found by calculating  $K = -\sigma(\sigma + \frac{K_p}{V})$ . Differentiating we get

$$\frac{dK}{d\sigma} = -2\sigma - \frac{K_p}{V} = 0 \text{ so } \sigma = -\frac{K_p}{2V}. \text{ The root locus is:}$$

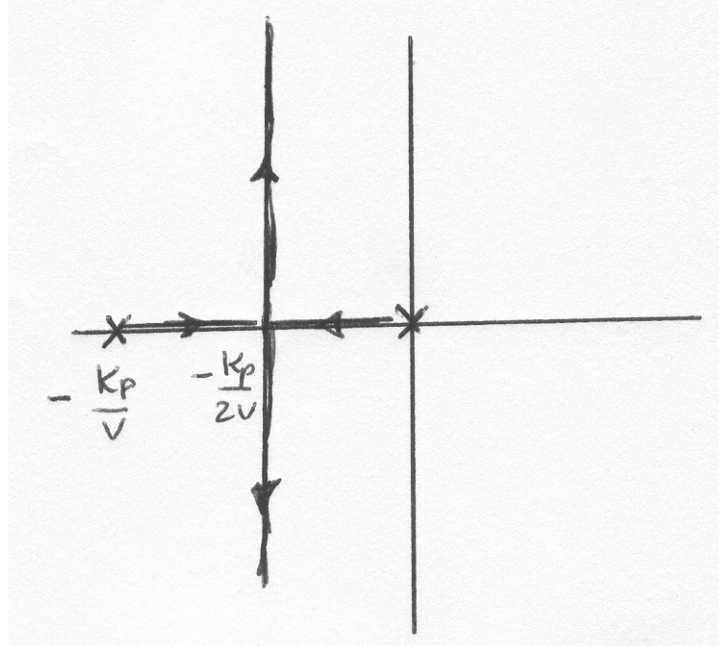

53.

After applying the Padé approximation

$$G(s) = \frac{7031250L(1 - 0.2s)}{(s + 0.667)(s + 5)(s + 50)} = -\frac{1406250L(s - 0.2)}{(s + 0.667)(s + 5)(s + 50)}$$

so this is a positive feedback system.

We start by finding out the range of  $L$  for closed loop stability. The characteristic equation is

$$1 - \frac{1406250L(s - 0.2)}{(s + 0.667)(s + 5)(s + 50)} = 0 \text{ or}$$

$$s^3 + 55.67s^2 + (286.7 - 1406250L)s + (166.8 + 281250L) = 0. \text{ The Routh array is}$$

$s^3$	1	$286.7 - 1406250L$
$s^2$	55.67	$166.8 + 281250L$
$s$	$283.7076 - 1411300L$	
1	$166.8 + 281250L$	

The resulting stability range is  $-5.93 \times 10^{-4} < L < 2.01 \times 10^{-4}$

The root locus will have two asymptotes with angles  $\theta = 0, \pi$

For the breakaway break-in points, write

$$K = \frac{(\sigma + 0.667)(\sigma + 5)(\sigma + 50)}{406251(\sigma - 0.2)} = \frac{\sigma^3 + 55.67\sigma^2 + 286.7\sigma + 166.8}{406251(\sigma - 0.2)}. \text{ The derivative of}$$

this expression is

$$\frac{dK}{d\sigma} = \frac{(\sigma - 0.2)(3\sigma^2 + 111.34\sigma + 286.7) - (\sigma^3 + 55.67\sigma^2 + 286.7\sigma + 166.8)}{406251(\sigma - 0.2)^2} = \frac{2\sigma^3 + 55.07\sigma^2 - 22.7\sigma - 224.1}{406251(\sigma - 0.2)^2}$$

The roots of the numerator are:  $\sigma = -27.8, 2.14, -1.88$  of which the latter two are in the root locus.

We find the values of  $L$  at 2.14 and -1.88 as follows

$$1 - \frac{1406250L(s - 0.2)}{(s + 0.667)(s + 5)(s + 50)} \Big|_{s=-1.88} = 0 \text{ giving } L = 6.2661 \times 10^{-5} \text{ and}$$

$$1 - \frac{1406250L(s - 0.2)}{(s + 0.667)(s + 5)(s + 50)} \Big|_{s=2.14} = 0 \text{ giving } L = 3.83 \times 10^{-4}$$

The root locus is:

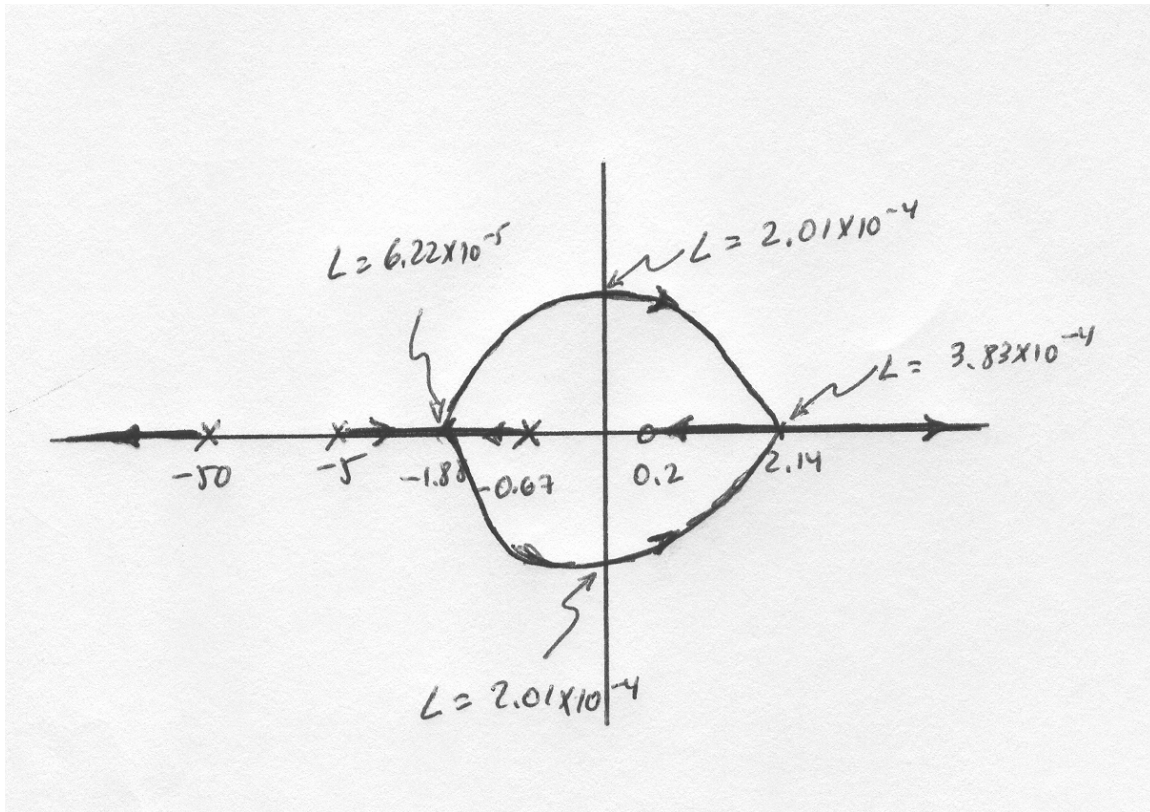

54.

a. Using Mason's rule it can readily be found that (with  $d=0$ ) the open loop transmission from  $u_r$  to  $u_o$  is

$$\frac{u_o}{u_r} = \frac{K_T \frac{(K_v \tau s + 1)}{\tau s} K_m \frac{1}{Ls} \frac{1}{Cs}}{1 + K_m \frac{1}{Ls} \alpha + \frac{1}{LCs^2} + \frac{C_L}{C}} = \frac{K_T K_m (K_v \tau s + 1)}{\tau s [L(C + C_L)s^2 + K_m \alpha Cs + 1]}$$

So the system's characteristic equation is:

$$1 + \beta \frac{K_T K_m (K_v \tau s + 1)}{\tau s [L(C + C_L)s^2 + K_m \alpha Cs + 1]} = 0$$

or

$$\tau L(C + C_L)s^3 + K_m \alpha C \tau s^2 + [\tau + \beta K_T K_m K_v \tau]s + \beta K_T K_m = 0$$

b. Substituting numerical values the characteristic equation becomes

$$15.2\mu(11\mu + C_L)s^3 + 14.52\mu s^2 + 73.7375ms + 2.39125 = 0$$

The Routh array is

$s^3$	$15.2\mu(11\mu + C_L)$	$73.7375m$
$s^2$	$14.52\mu$	$2.39125$
$s$	$\frac{36.347\mu(11\mu + C_L) - 1.07067\mu}{-14.52\mu}$	
1	$2.39125$	

To have all the first column positive it is required that

$$C_L > -11\mu F \text{ and } C_L < 29.45mF . \text{ It follows that}$$

$$0 < C_L < 29.45mF \text{ due to physical restrictions in the capacitance.}$$

The characteristic equation can also be expressed as

$$1 + C_L \frac{90909s^3}{s^3 + 86842s^2 + 4.4101 \times 10^8 s + 1.5212 \times 10^{10}} = 0 \text{ or}$$

$$1 + C_L \frac{90909s^3}{(s + 35)(s + 5379)(s + 81428)} = 0 .$$

There are no asymptotes. The break-in and breakaway points are calculated by first obtaining

$$C_L = -\frac{\sigma^3 + 86842\sigma^2 + 4.4101 \times 10^8 \sigma + 1.5212 \times 10^{10}}{90909\sigma^3} . \text{ Then differentiating,}$$

$$\frac{dC_L}{d\sigma} = -\frac{\sigma^3(3\sigma^2 + 173684\sigma + 4.4101 \times 10^8) - (\sigma^3 + 86842\sigma^2 + 4.4101 \times 10^8 \sigma + 1.5212 \times 10^{10})3\sigma^2}{90909\sigma^6}$$

$$= \frac{86842\sigma^4 + 7.893 \times 10^8 \sigma^3 + 4.564 \times 10^{10} \sigma^2}{90909\sigma^6} \text{ The roots of the numerator are}$$

$$\sigma = 0, 0, -9030.7, -58.2$$



The value of  $C_L$  at -9030.7 is obtained

$$\text{from } 1 + C_L \frac{90909s^3}{s^3 + 86842s^2 + 4.4101 \times 10^8 s + 1.5212 \times 10^{10}} \Big|_{s=-9030.7} = 0 \text{ giving}$$

$$C_L = 3.5523 \times 10^{-5}$$

The root locus is:

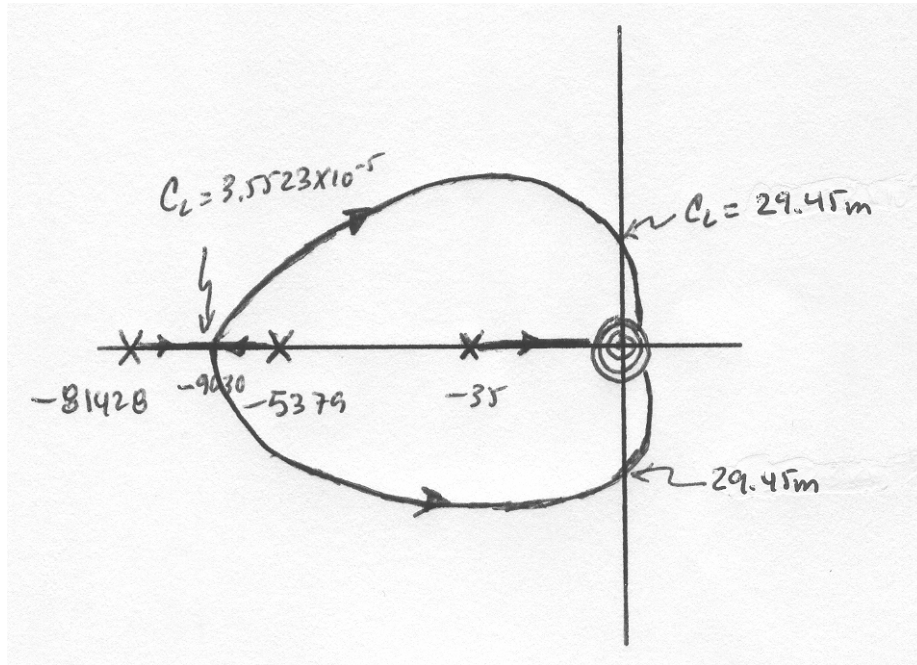

55.

a. Substituting values we have

$$G_d(s) = 0.003 \left( 1 + \frac{K}{s} \right) \frac{s-0.5}{s+0.5}, \text{ and } G_t(s) = \frac{0.1538}{s(s+0.833)}$$

The systems characteristic equation is

$$1 + G_d G_t = 1 + 4.614 \times 10^{-4} \left( 1 + \frac{K}{s} \right) \frac{s-0.5}{s(s+0.833)(s+0.5)} = 0$$

Which can be rewritten as:

$$1 + K \frac{4.614 \times 10^{-4} (s-0.5)}{s^4 + 1.333s^3 + 0.417s^2 - 2.308 \times 10^{-4} s} = 0$$

or

$$1 + K \frac{4.614 \times 10^{-4} (s-0.5)}{s(s-0.0006)(s+0.5029)(s+8306)} = 0$$

There are 3 asymptotes with a real axis intersection at

$$\sigma_a = \frac{0 + 0.0006 - 0.5029 - 0.8306 - 0.5}{4-1} = -0.61$$

The breakaway points are found by defining

$$N(s) = s - 0.5 \text{ and } D(s) = s^4 + 1.333s^3 + 0.417s^2 - 2.308 \times 10^{-4} s. \text{ Then } N'(s) = 1;$$

$$D'(s) = 4s^3 + 4s^2 + 0.834s - 2.308 \times 10^{-4}$$

Then  $N(s)D'(s) - N'(s)D(s) = 0$  becomes

$$3s^4 + 0.667s^3 - 1.583s^2 - 0.417s + 1.154 \times 10^{-4} = 0$$

That has roots at  $s = 0.7417, -0.694, -0.2703, 0, 0003$ . The only solution in the locus is -

0.2703.

The roots locus is:

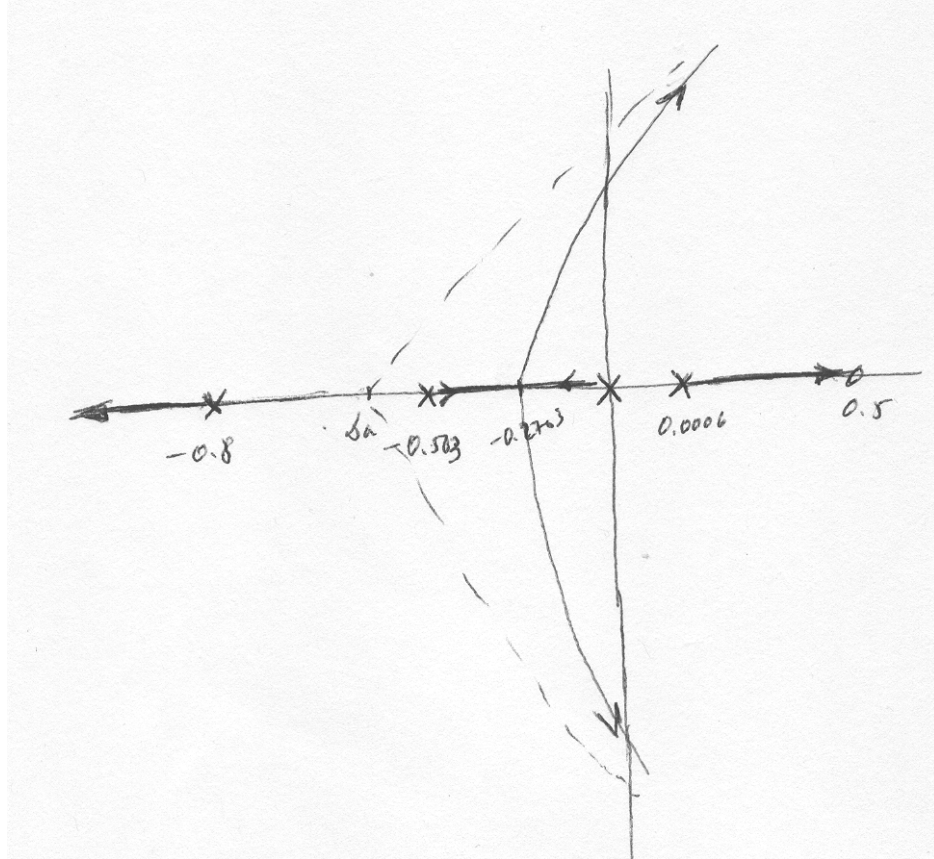

b. The system is unstable for all values of  $K$ , although with relatively large time constants for small  $K$ . It is very unlikely that the driver-train system is unstable.

56.

$$\text{a. } Z_{req} = \frac{R_r \times \frac{1}{C_r s}}{R_r + \frac{1}{C_r s}} = \frac{R_r}{R_r \times C_r s + 1} = \frac{5}{0.04s + 1} \quad \&$$

$$Z_{cable} = R_{cable} + L_{cable} s = 0.06 + 0.00005s$$

Hence:

$$\begin{aligned} \frac{1}{Z_{cable} + Z_{req}} &= \frac{1}{0.06 + 0.00005s + \frac{5}{0.04s + 1}} = \frac{0.04s + 1}{(0.06 + 0.00005s)(0.04s + 1) + 5} \\ &= \frac{0.04s + 1}{2E - 6 \times s^2 + 0.00245s + 5.06} = \frac{20000s + 500000}{s^2 + 1225s + 2530000} \end{aligned}$$

$$\text{Thus: } G(s) = \frac{V_s(s)}{I_s(s)} = \frac{s^2 + 1225s + 2530000}{(s^2 + 1225s + 2530000)0.008s + (20000s + 500000)} =$$

$$= \frac{s^2 + 1225s + 2530000}{0.008s^3 + 9.8s^2 + 40240s + 500000}$$

b. The transfer function of the forward loop,  $KG(s)$ :

$$KG(s) = \frac{V_s(s)}{E_v(s)} = \frac{K(s^2 + 1225s + 2530000)}{0.008s^3 + 9.8s^2 + 40240s + 500000}$$

The transfer function of the feedback loop is given by:  $H(s) = \frac{200}{s + 200}$ .

The system's characteristic equation is:

$$1 + \left( \frac{K(s^2 + 1225s + 2530000)}{0.008s^3 + 9.8s^2 + 40240s + 500000} \right) \left( \frac{200}{s + 200} \right) = 0$$

Or equivalently

$$s^4 + 1425s^3 + (5275000 + 25000K)s^2 + (1.0685 \times 10^9 + 3.0625 \times 10^7 K)s + (1.25 \times 10^{10} + 6.325 \times 10^{10} K) = 0$$

The following MATLAB M-file was written to plot the root locus for the system and to find the required-above operational parameters and functions:

```
numg = [1 1225 2.53E6];
deng = [0.008 9.8 40240 500000];
G = tf(numg, deng);
numh = 200;
denh = [1 200];
H = tf(numh, denh);
rlocus(G*H);
title('Full Root Locus for DC Bus Voltage Control System')
pause
axis([-150, 0, -150, 150]);
z=0.707;
sgrid(z,0)
```

```

title('Root Locus Zoomed-in around Dominant Poles with a 0.707
Damping Line')

[K1,p]=rlocfind(G*H);

pause

K = K1;

T=feedback(K*G,H);      %T is the closed-loop TF of the system

T=minreal(T);

step(750*T);

grid

title('Step Response of DC Bus Voltage')

```

The first figure shown below is the full root locus for that system.

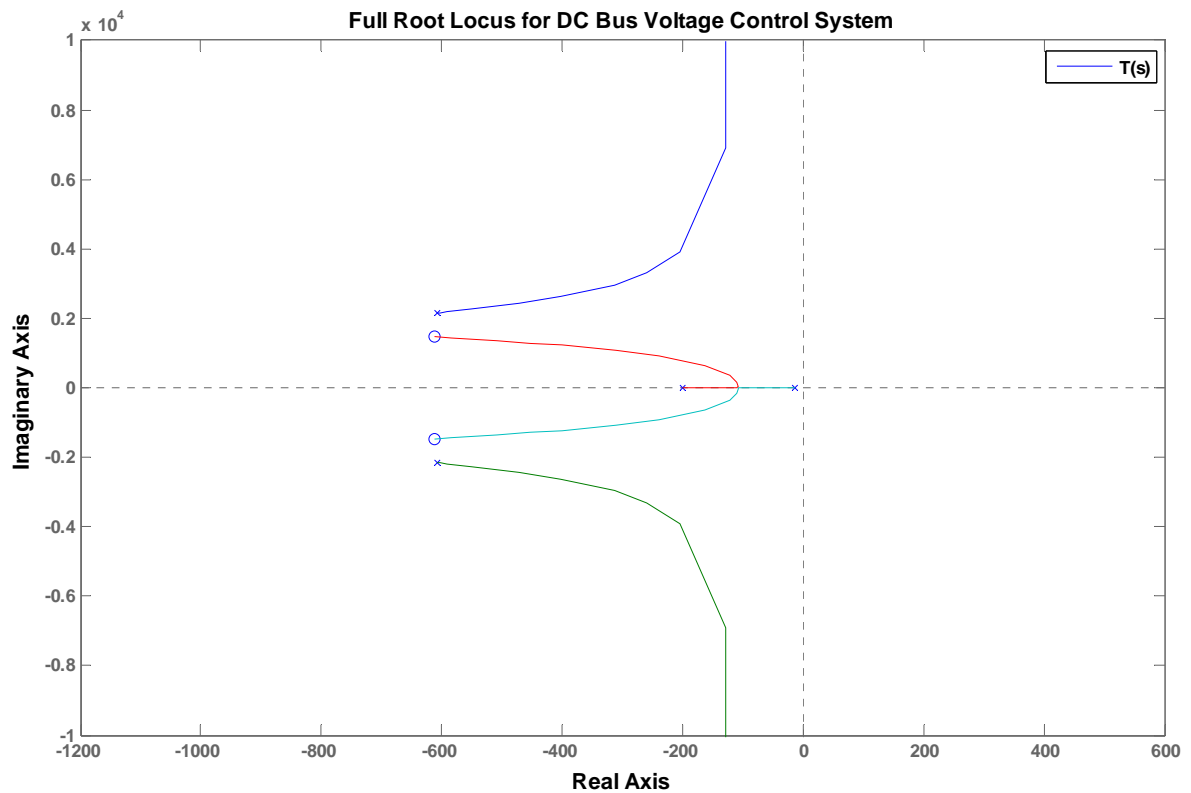

Zooming into the locus by setting the x-axis (real-axis) limits to -150 to 0 and the y-axis (imaginary-axis) limits to -150 to 150, we get the following Root locus with the line corresponding to a damping ratio,  $\zeta = 0.707$ . That plot was used to find the gain,  $K$ , at which the system has complex-conjugate closed-loop dominant poles with a damping ratio  $\zeta = 0.707$ .

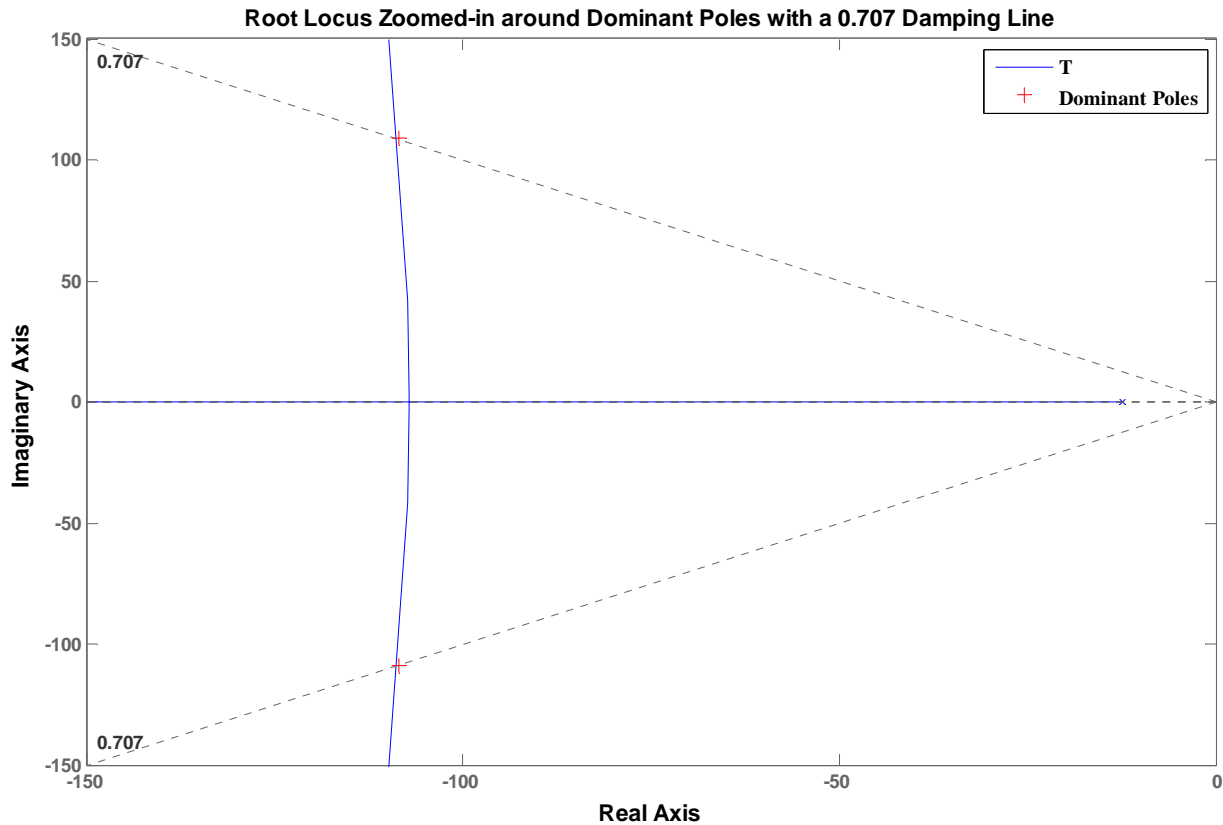

From the locus we found that:

- i. The gain,  $K$ , at which the system would have complex-conjugate closed-loop dominant poles with a damping ratio  $\zeta = 0.707$  is:  $K = 1.6832$ ;
- ii. The coordinates of the corresponding point selected on the root-locus are:

$$-1.085 \text{ E}+002 \quad +1.090 \text{ E}+002i$$

- iii. The corresponding values of all closed-loop poles are:

$$p = \quad 1.0 \text{ E}+003 *$$

$$-0.6040 + 2.1602i$$

$$-0.6040 - 2.1602i$$

$$-0.1085 + 0.1090i$$

$$-0.1085 - 0.1090i$$

iv. The output voltage  $v_s(t)$  for a step input voltage  $v_{dc-ref}(t) = 750 u(t)$  was plotted in (c) below.

c. The output response is shown below with the required characteristics noted on the graph and listed below.

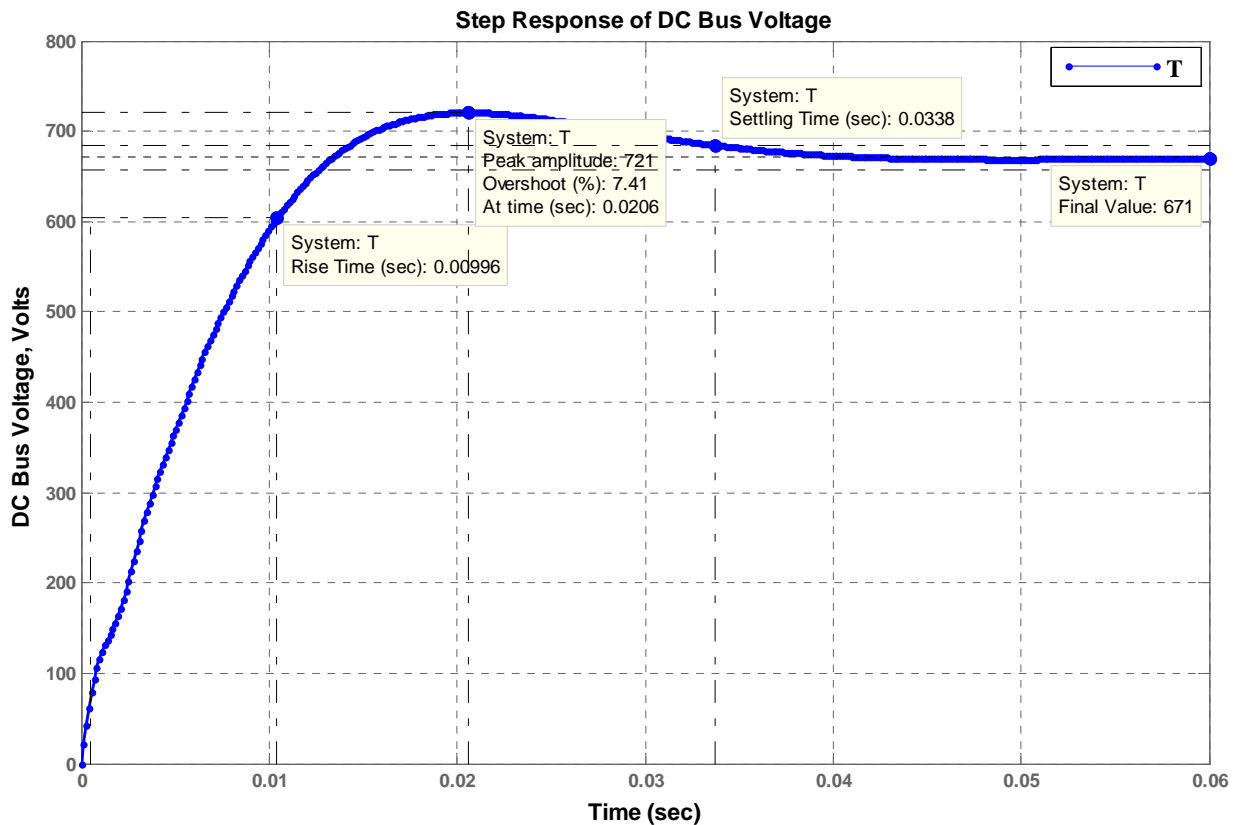

- i. The actual percent overshoot = 7.41% and the corresponding peak time,  $T_p = 0.0206$  sec;
- ii. The rise time,  $T_r = 0.00996$  sec, and the settling time,  $T_s = 0.0338$  sec;
- iii. The final steady-state value is 671 volts.

## SOLUTIONS TO DESIGN PROBLEMS

57.

a. For a settling time of 0.1 seconds, the real part of the dominant pole is  $-\frac{4}{0.1} = -40$ . Searching along the  $\sigma = -40$  line for  $180^\circ$ , we find the point  $-40 + j57.25$  with  $20,000K = 2.046 \times 10^9$ , or  $K = 102,300$ .

b. Since, for the dominant pole,  $\tan^{-1}\left(\frac{57.25}{40}\right) = 55.058^\circ$ ,  $\zeta = \cos(55.058^\circ) = 0.573$ . Thus,

$$\%OS = e^{-\zeta/\sqrt{1-\zeta^2}} \times 100 = 11.14\%.$$

c. Searching the imaginary axis for  $180^\circ$ , we find  $\omega = 169.03$  rad/s for  $20,000K = 1.43 \times 10^{10}$ . Hence,  $K = 715,000$ . Therefore, for stability,  $K < 715,000$ .

58.

$$G(s) = \frac{61.73K}{(s+10)^3 (s^2 + 11.11s + 61.73)}$$

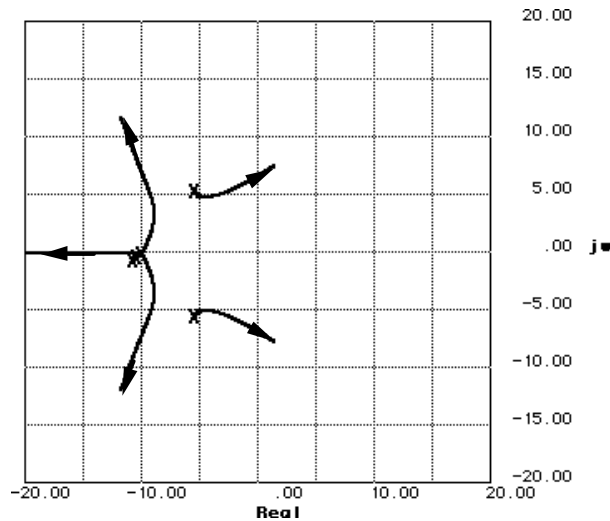

a. Root locus crosses the imaginary axis at  $\pm j6.755$  with  $61.73K$  equal to 134892.8. Thus for oscillations,  $K = 2185.21$ .

b. From (a) the frequency of the oscillations is 6.755 rad/s.

c. The root locus crosses the 20% overshoot line at  $6 \angle 117.126^\circ = -2.736 + j5.34$  with  $61.73K = 23323.61$ . Thus,  $K = 377.83$  and  $T_s = \frac{4}{\zeta\omega_n} = \frac{4}{2.736} = 1.462$  seconds.

59.

a. Finding the transfer function with  $C_a$  as a parameter,



$$\frac{Y_m(s)}{Y_G(s)} = \frac{s^2(2s+2)}{(C_a+1)s^2+4s+2} = \frac{\frac{2s^2(s+1)}{s^2+4s+2}}{1 + \frac{C_a s^2}{s^2+4s+2}}$$

Plotting the root locus,

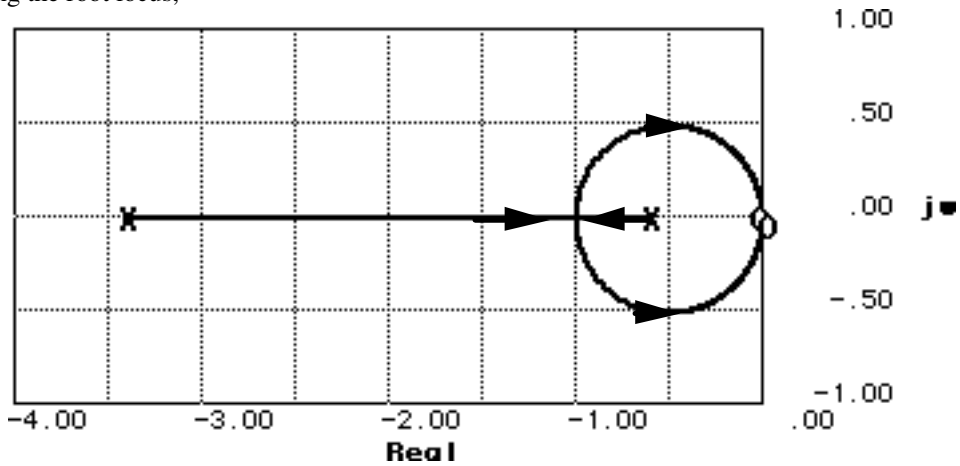

b. Since  $2\zeta\omega_n = \frac{4}{C_a+1}$  ;  $\omega_n^2 = \frac{2}{C_a+1}$  ,  $\zeta^2 = \frac{2}{C_a+1} = 0.69^2$ . Hence,  $C_a = 3.2$ .

60.

a.

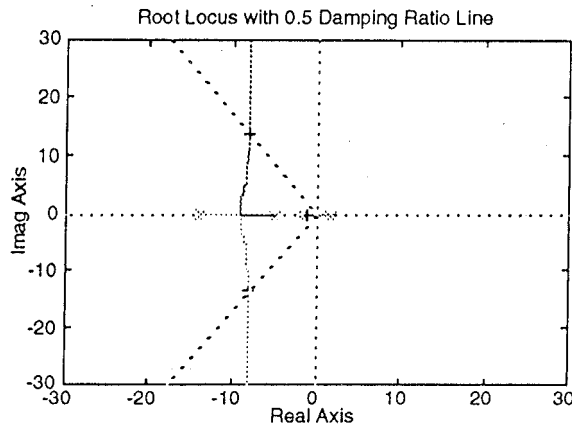

b. The pole at 1.8 moves left and crosses the origin at a gain of 77.18. Hence, the system is stable for  $K > 77.18$ , where  $K = -508K_2$ . Hence,  $K_2 < -0.152$ .

c. Search the  $\zeta = 0.5$  ( $\theta = 120^\circ$ ) damping ratio line for  $180^\circ$  and find the point,  $-8.044 + j13.932 = 16.087 \angle 120^\circ$  with a  $K = -508K_2 = 240.497$ . Thus,  $K_2 = -0.473$ .

d. Search the real axis between 1.8 and -1.6 for  $K = 240.497$  and find the point -1.01.

$$\text{Thus } G_e(s) = \frac{240.497K_1(s+1.6)}{s(s+1.01)(s+8.044+j13.932)(s+8.044-j13.932)} = \frac{240.497K_1(s+1.6)}{s(s+1.01)(s^2+16.088s+258.8066)} .$$

Plotting the root locus and searching the  $j\omega$  axis for  $180^\circ$  we find  $j15.792$  with  $240.497K_1 = 4002.6$ , or  $K_1 = 16.643$ .

e.

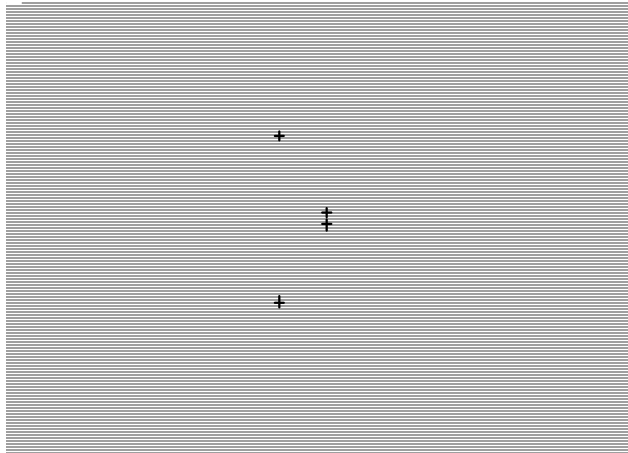

Search the  $\zeta = 0.45$  ( $\theta = 116.744^\circ$ ) damping ratio line for  $180^\circ$  and find the point,  $-6.685 + j13.267 = 14.856 \angle 116.744^\circ$  with a  $K = 240.497K_1 = 621.546$ . Thus,  $K_1 = 2.584$ .

61.

a. Update the block diagram to show the signals that form  $H_{\text{sys}}(s)$ .

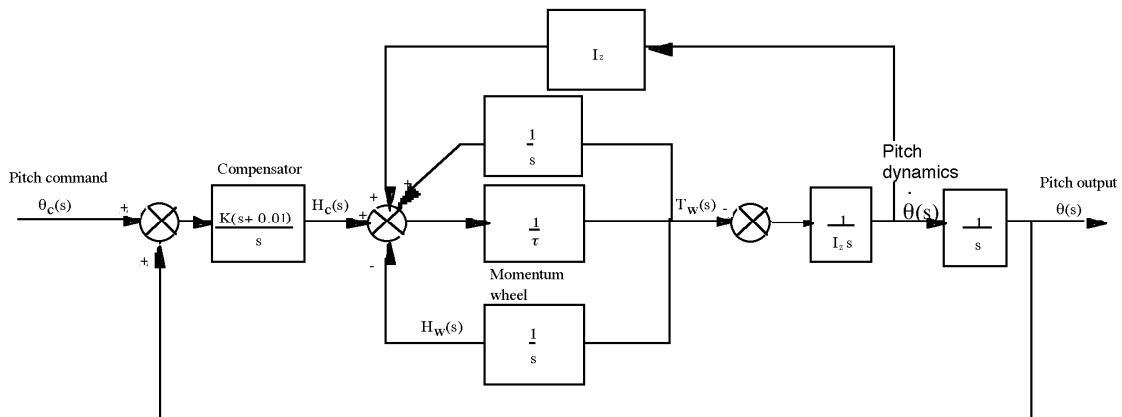

Perform block diagram reduction of the parallel paths from  $T_w(s)$ .

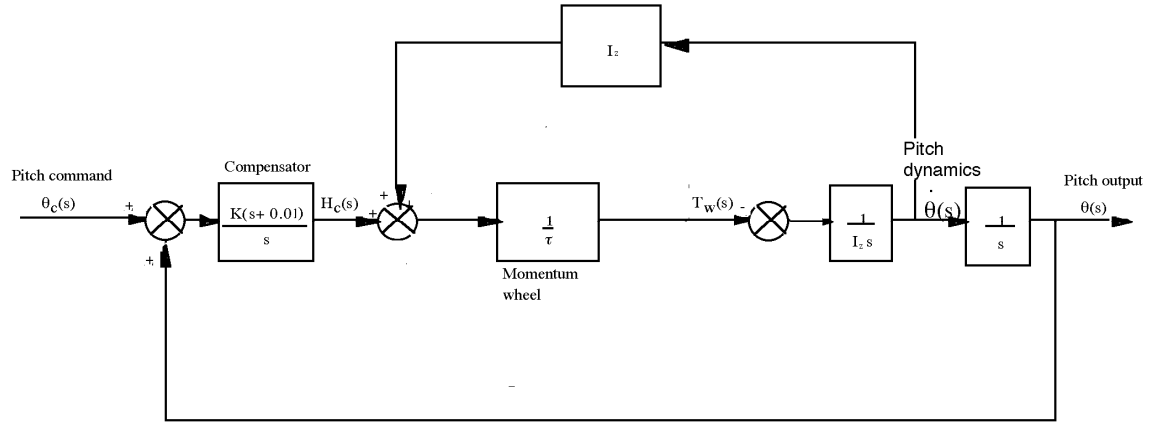

Reduce the momentum wheel assembly to a single block.

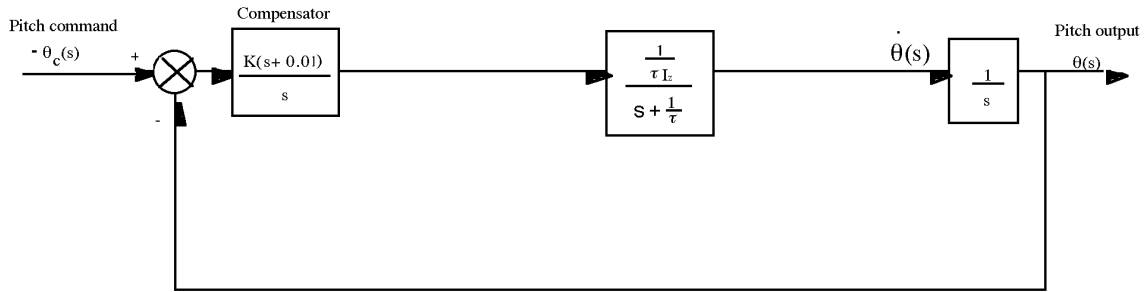

Substitute values and find  $G_e(s) = \frac{4.514 \times 10^{-6} K(s + 0.01)}{s^2(s + 0.043)}$ . Plotting the root locus yields

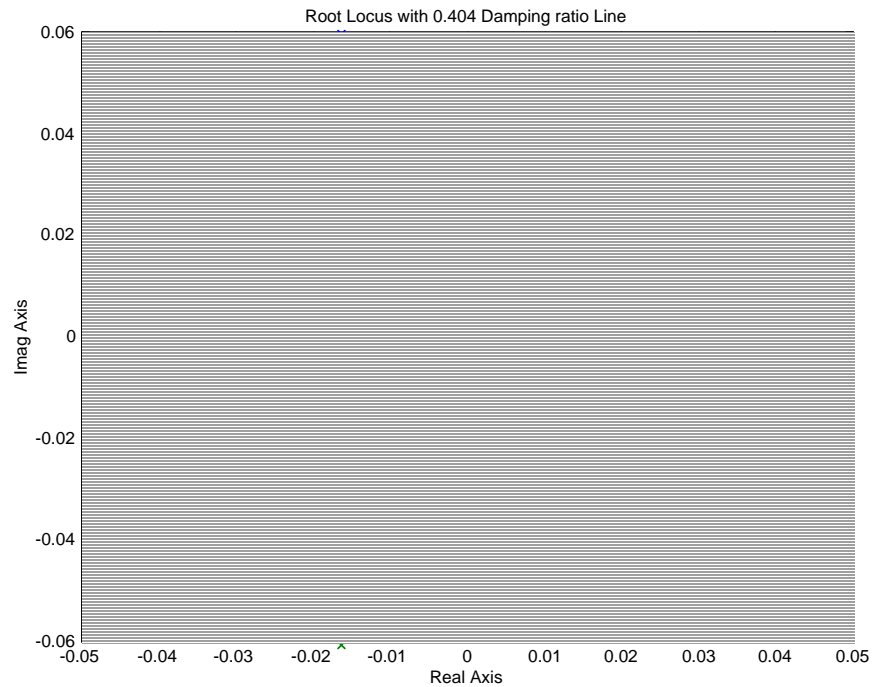

**b.** Searching the 25% overshoot line ( $\zeta = 0.404$ ;  $\theta = 113.8^\circ$ ) for  $180^\circ$  yields

$-0.0153 + j0.0355$  with a gain  $= 4.514E-6K = 0.0019$ . Thus,  $K = 420.9$ .

**c.** Searching the real axis between  $-0.025$  and  $-0.043$  for a gain of  $0.0019$ , we find the third pole at  $-0.0125$ . Simulate the system. There is no pole-zero cancellation. A simulation shows approximately 95% overshoot. Thus, even though the compensator yields zero steady-state error, a system redesign for transient response is necessary using methods discussed in Chapter 9.

62.  
a.

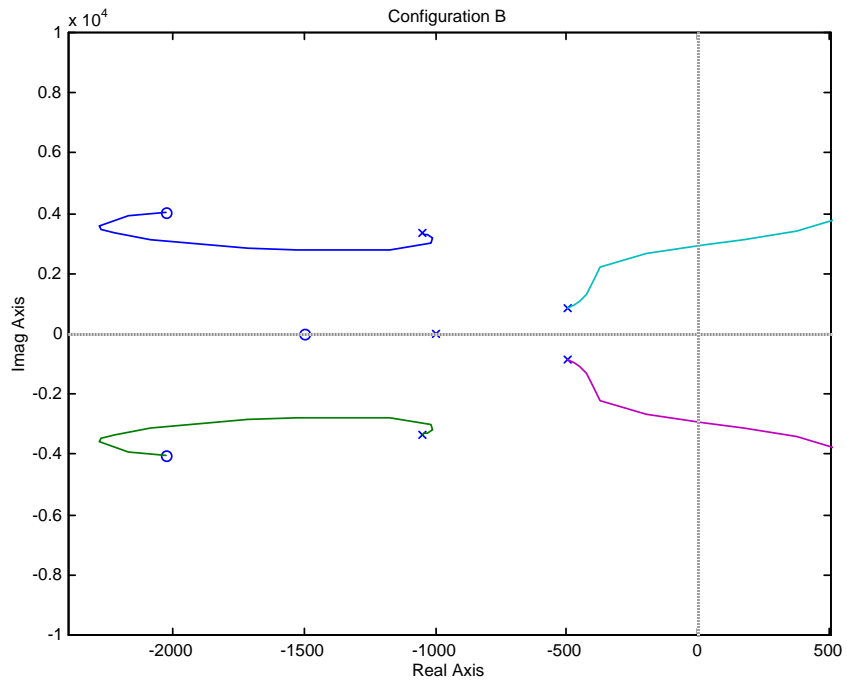
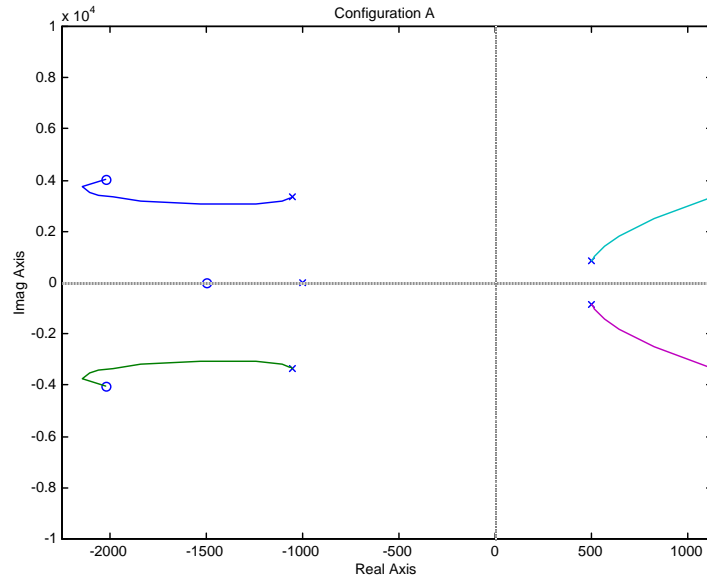

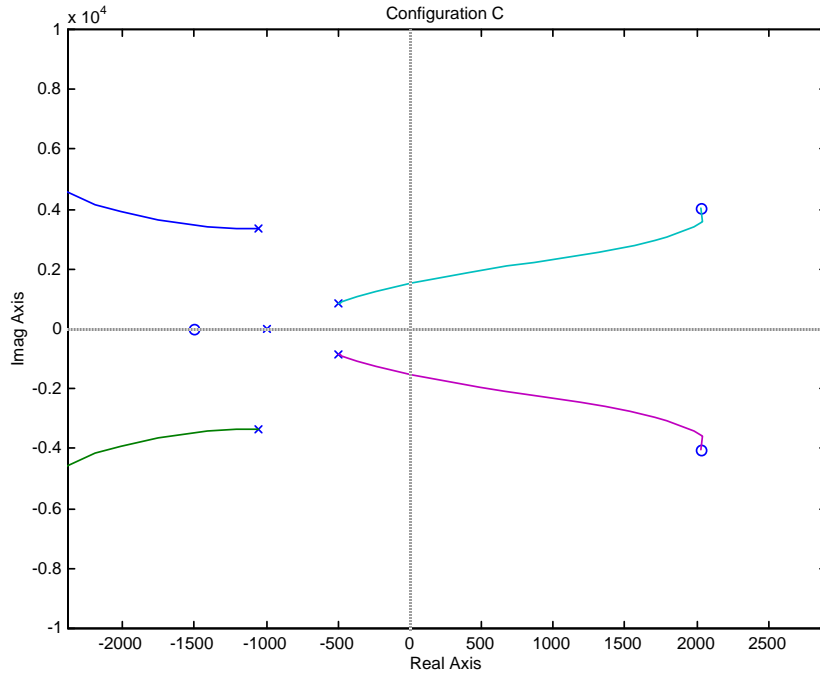

**b.**

**Configuration A:** System is always unstable.

**Configuration B:** root locus crosses  $j\omega$  axis at  $j2897$  with a gain of  $3.22 \times 10^6$ . Thus, for stability,  $K < 3.22 \times 10^6$ .

**Configuration C:** root locus crosses  $j\omega$  axis at  $j1531$  with a gain of  $9.56 \times 10^5$ . System is unstable at high gains. Thus, for stability,  $9.56 \times 10^5 > K$ .

**63.**

**a.** Using MATLAB and the Symbolic Math Toolbox, the open-loop expression that yields a root locus as a function of  $N^2$  is

$$G_d(s) = \frac{0.2284 \times 10^7 N^2 (s^2 + 3.772 \times 10^{-5} s + 66.27) (s^2 + 49.99 s + 8789)}{s(s+45.12) (s^2 + 4.893 s + 8.777 \times 10^4)}$$

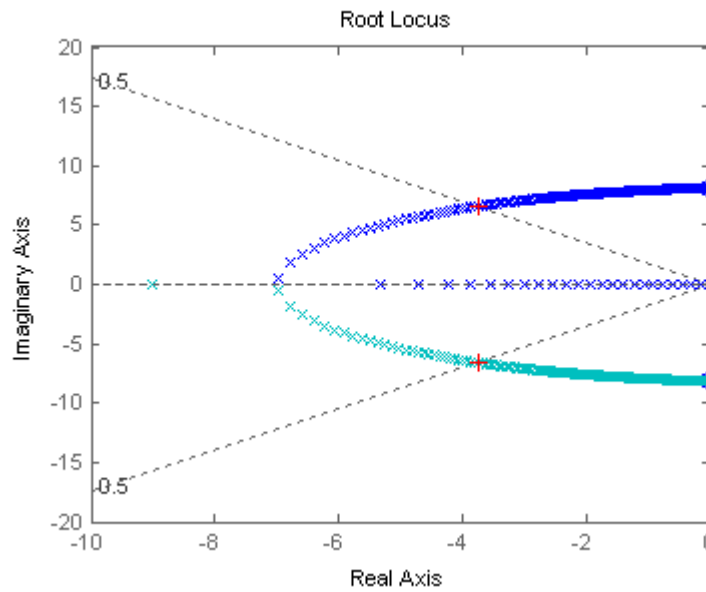
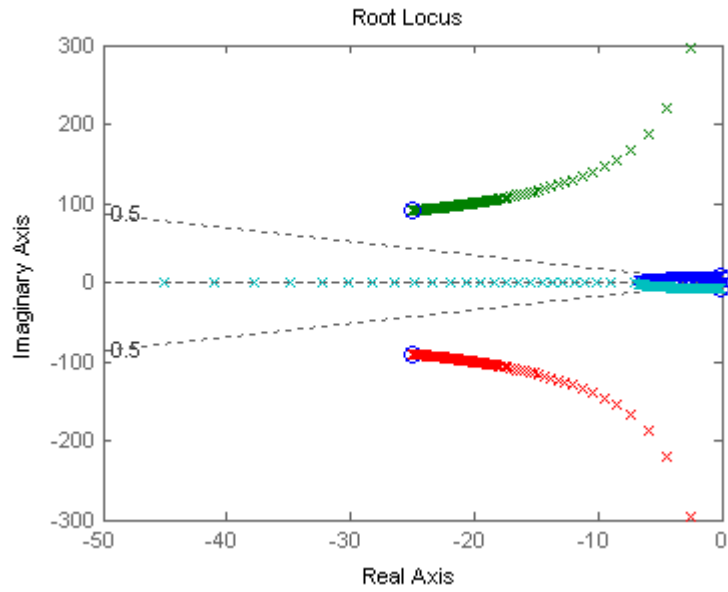

**Program:**

```

syms s N KLSS KHSS KG JR JG tel s
numGdt=3.92*N^2*KLSS*KHSS*KG*s;
denGdt=(N^2*KHSS*(JR*s^2+KLSS)*(JG*s^2*[tel*s+1]+KG*s)+JR*s^2*KLSS*[(JG*s^2
+KHSS)*(tel*s+1)+KG*s]);
Gdt=numGdt/denGdt;
'Gdt in General Terms'
pretty(Gdt)
'Values to Substitute'
KLSS=12.6e6
KHSS=301e3
KG=668
JR=190120
JG=3.8
tel=20e-3
    
```

```

numGdt=3.92*N^2*KLSS*KHSS*KG*s;
numGdt=vpa(numGdt,4);
denGdt=(N^2*KHSS*(JR*s^2+KLSS)*(JG*s^2*[tel*s+1]+KG*s)+JR*s^2*KLSS*[(JG*s^2
+KHSS)*(tel*s+1)+KG*s]);
denGdt=vpa(denGdt,4);
'Gdt with Values Substituted'
Gdt=numGdt/denGdt;
pretty(Gdt)
Gdt=expand(Gdt);
Gdt=vpa(Gdt,4);
'Gdt Different Form 1'
pretty(Gdt);
denGdt=collect(denGdt,N^2);
'Gdt Different Form 2'
Gdt=collect(Gdt,N^2);
pretty(Gdt)
[numGdt,denGdt]=numden(Gdt);
numGdt=numGdt/0.4349e10;
denGdt=denGdt/0.4349e10;
denGdt=expand(denGdt);
denGdt=collect(denGdt,N^2);
Gdt=vpa(numGdt/denGdt,4);
'Gdt Different Form 3'
pretty(Gdt)
'Putting into Form for RL as a Function of N^2 using previous results'
numGH=[1 49.99 8855 3313 582400];
denGH=[41.87 2094 0.3684e7 0.1658e9 0];
denGH=denGH/denGH(1)
GH=tf(numGH,denGH)
GHzpk=zpk(GH)
'Zeros of GH'
rootsnumGH=roots(numGH)
'Poles of GH'
rootsdenGH=roots(denGH)
K=0:1:10000;
rlocus(GH,K)
sgrid(0.5,0)
pause
axis([-10,0,-20,20])
[K,P]=rlocfind(GH)

```

**Computer response:**

ans =

Gdt in General Terms

$$\frac{3.92 N^2 KLSS KHSS KG s}{(N^2 KHSS (JR s^2 + KLSS) (JG s^2 (tel s + 1) + KG s) + JR s^2 KLSS ((JG s^2 + KHSS) (tel s + 1) + KG s))}$$

ans =

Values to Substitute

KLSS =

12600000



KHSS =

301000

KG =

668

JR =

190120

JG =

3.8000

tel =

0.0200

ans =

Gdt with Values Substituted

$$.9931 \cdot 10^{16} \frac{N^2 s^2}{(301000 \cdot N^2 (190100 \cdot s^2 + .1260 \cdot 10^8) (3.800 \cdot s^2 (.02000 \cdot s + 1.) + 668 \cdot s) + .2396 \cdot 10^{13} \cdot s^2 ((3.800 \cdot s^2 + 301000 \cdot s) (.02000 \cdot s + 1.) + 668 \cdot s))}$$

ans =

Gdt Different Form 1

$$.9931 \cdot 10^{16} \frac{N^2 s^2}{(.4349 \cdot 10^{10} N^2 s^5 + .2174 \cdot 10^{12} N^2 s^4 + .3851 \cdot 10^{14} N^2 s^3 + .1441 \cdot 10^{14} N^2 s^2 + .2533 \cdot 10^{16} N^2 s + .1821 \cdot 10^{12} s^5 + .9105 \cdot 10^{13} s^4 + .1602 \cdot 10^{17} s^3 + .7212 \cdot 10^{18} s^2)}$$

ans =

Gdt Different Form 2

$$.9931 \cdot 10^{16} \frac{N^2 s^2}{(.4349 \cdot 10^{10} s^5 + .2174 \cdot 10^{12} s^4 + .3851 \cdot 10^{14} s^3)}$$

8-76 Chapter 8: Root Locus Techniques

$$\frac{.2284 \times 10^7 N^2 s^2}{(1.000 \times 10^5 s^5 + 49.99 \times 10^4 s^4 + 8855. s^3 + 3313. s^2 + 582400. s) N^2 + (.9105 \times 10^{13} s^4 + .1602 \times 10^{17} s^3) N^2 + (.7212 \times 10^{18} s^2 + .1821 \times 10^{12} s) N^2 + .1441 \times 10^{14} s^2 + .2533 \times 10^{16} s) N^2}$$

ans =

Gdt Different Form 3

$$\frac{.2284 \times 10^7 N^2 s^2}{(1.000 \times 10^5 s^5 + 49.99 \times 10^4 s^4 + 8855. s^3 + 3313. s^2 + 582400. s) N^2 + (.9105 \times 10^9 s^2 + 41.87 \times 10^5 s + 2094. s^4 + .3684 \times 10^7 s^3) N^2}$$

ans =

Putting into Form for RL as a Function of N^2 using previous results

denGH =

```
1.0e+006 *
Columns 1 through 4
    0.0000    0.0001    0.0880    3.9599
Column 5
    0
```

Transfer function:

$$\frac{s^4 + 49.99 s^3 + 8855 s^2 + 3313 s + 582400}{s^4 + 50.01 s^3 + 8.799e004 s^2 + 3.96e006 s}$$

Zero/pole/gain:

$$\frac{(s^2 + 66.27) (s^2 + 49.99s + 8789)}{s (s+45.12) (s^2 + 4.893s + 8.777e004)}$$

ans =

Zeros of GH

rootsnumGH =

```
-24.9950 +90.3548i
-24.9950 -90.3548i
-0.0000 + 8.1404i
```

-0.0000 - 8.1404i

ans =

Poles of GH

rootsdenGH =

1.0e+002 \*  
 0  
 -0.0245 + 2.9624i  
 -0.0245 - 2.9624i  
 -0.4512

Select a point in the graphics window

selected\_point =

-3.8230 + 6.5435i

K =

51.5672

P =

-21.1798 +97.6282i  
 -21.1798 -97.6282i  
 -3.8154 + 6.5338i  
 -3.8154 - 6.5338i

b. From the computer response,  $K = 0.2284 \times 10^7 N^2 = 49.6$ . Therefore,  $N$  is approximately  $5/1000$ .

64.

a. There are two asymptotes with  $\theta_a = \frac{\pi}{2}, \frac{3\pi}{2}$  and real axis intersection

$$\sigma_a = \frac{0+0-10-(-1)}{3-1} = -4.5. \text{ To find the breakaway and break-in points, write}$$

$$K = \frac{\sigma^2(\sigma+10)}{3.333 \times 10^4(\sigma+1)}. \text{ The derivative of this expression is}$$

$$\frac{dK}{d\sigma} = -\frac{(\sigma+1)(3\sigma^2+20\sigma) - (\sigma^3+10\sigma^2)}{3.3333 \times 10^4(\sigma+1)^2} = -\frac{\sigma(2\sigma^2+13\sigma+20)}{3.3333 \times 10^4(\sigma+1)^2}. \text{ The denominators}$$

roots for this expression are  $\sigma = 0, -2.5, -4$

The values of  $K$  at -2.5 and -4 are calculated from

$$1 + K \frac{3.333 \times 10^4(s+1)}{s^2(s+10)} \Big|_{s=-2.5} = 0 \text{ giving } K = 9.375 \times 10^{-4} \text{ and}$$

$$1 + K \frac{3.333 \times 10^4 (s+1)}{s^2 (s+10)} \Big|_{s=-4} = 0 \text{ giving } K = 9.6 \times 10^{-4}$$

The root locus is:

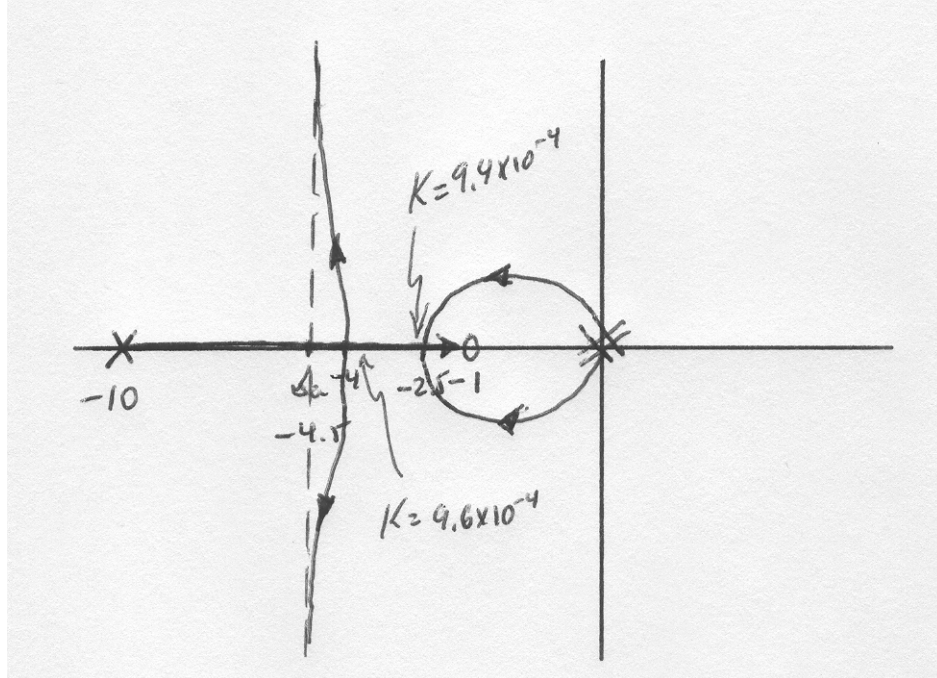

b. The line corresponding to  $\xi = 0.7$  must be at an angle  $\theta = \cos^{-1} 0.7 = 45.57^\circ$  so the line must lie along the points  $s = a + jb = a - ja \tan \theta = a(1 - j1.0202)$ . The angle condition for

the root locus must be satisfied. Namely

$$\arg\left(\frac{3.333 \times 10^4 (s+1)}{s^2 (s+10)} \Big|_{s=a(1-j1.0202)}\right) = \arg\left(\frac{3.333 \times 10^4 (1+a-j1.0202)}{a^2 (1-j1.0202)^2 (10+a-j1.0202)}\right)$$

$$= -\tan^{-1} \frac{1.0202}{1+a} + \tan^{-1} \frac{1.0202}{10+a} - 2(-45.57^\circ) = 180^\circ$$

A numerical search gives  $a = -1.136$ . So the root locus and the line intersect when

$s = -1.136(1 - j1.0202) = -1.136 + j1.1589$ . Then the value of  $K$  can be found

$$\text{from } 1 + K \frac{3.333 \times 10^4 (s+1)}{s^2 (s+10)} \Big|_{s=-1.136+j1.1589} = 0 \text{ giving } K = 6.05 \times 10^{-4}$$

65.

a. The open loop transfer function can be expressed as  $G(s) = \left(\frac{K_p s + K_I}{s^2}\right) \frac{48500}{s+2.89}$ . The

Acceleration Error Constant is given by

$$K_a = \lim_{s \rightarrow 0} s^2 G(s) = \lim_{s \rightarrow 0} \frac{48500(K_p s + K_I)}{s + 2.89} = 16872 K_I. \text{ For a parabolic input}$$

$$e_{ss} = \frac{1}{K_a} = \frac{1}{16872 K_I} = 0.02. \text{ This gives } K_I = 0.003$$

b. The characteristic equation is  $1 + \left( \frac{K_p s + 0.003}{s^2} \right) \frac{48500}{s + 2.89} = 0$  or

$$s^3 + 2.89s^2 + K_p s + 0.003 = 0 \text{ We start by finding the range of } K_p \text{ for closed loop stability.}$$

The Routh array is

$s^3$	1	$K_p$
$s^2$	2.89	0.003
$s$	$\frac{2.89K_p - 0.003}{2.89}$	
1	0.003	

So for closed loop stability  $K_p > 0.001$

To draw the root locus we write the characteristic equation

$$\text{as } 1 + K_p \frac{s}{s^3 + 2.89s^2 + 0.003} = 0 \text{ or } 1 + K_p \frac{s}{(s + 2.89)(s^2 - 0.0004s + 0.001037)} = 0$$

There are two asymptotes with  $\theta_a = \frac{\pi}{2}, \frac{3\pi}{2}$  and real axis intersection

$$\sigma_a = \frac{-2.89 - 2(0.0002) - 0}{3 - 1} = -1.4452. \text{ To find the break-in and breakaway points we write}$$

$$K_p = -\frac{\sigma^3 + 2.89\sigma^2 + 0.003}{\sigma}. \text{ We obtain}$$

$$\frac{dK_p}{d\sigma} = -\frac{\sigma(3\sigma^2 + 5.78\sigma) - (\sigma^3 + 2.89\sigma^2 + 0.003)}{\sigma^2} = -\frac{2\sigma^3 + 2.89\sigma^2 - 0.003}{\sigma^2} \text{ The}$$

roots of the numerator are  $\sigma = 0.0319, -0.0326, -1.4443$ . We obtain the values of  $K_p$  at -

0.0326 and -1,443 from

$$1 + K_p \frac{s}{s^3 + 2.89s^2 + 0.003} \Big|_{s=-0.0326} = 0 \text{ giving } K_p = 0.1852 \text{ and}$$

$$1 + K_p \frac{s}{s^3 + 2.89s^2 + 0.003} \Big|_{s=-1.4443} = 0 \text{ giving } K_p = 2.0901$$

The root locus is:

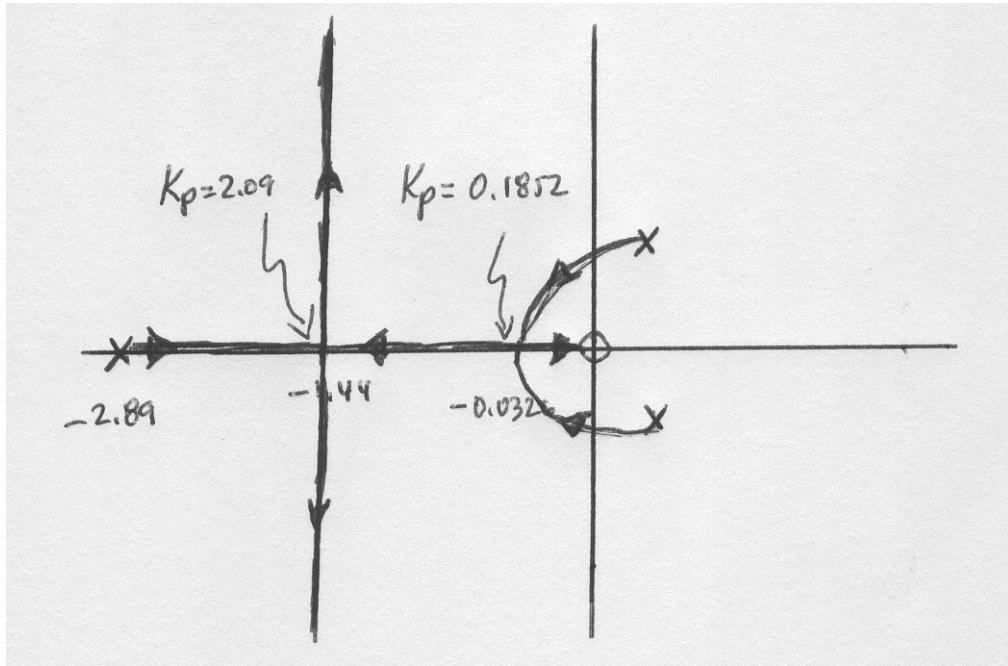

c. The value of  $K_p$  when the system has a closed loop pole at -1 is obtained from

$$1 + K_p \frac{s}{s^3 + 2.89s^2 + 0.003} \Big|_{s=-1} = 0 \text{ resulting in } K_p = 1.893. \text{ With this value of gain the}$$

characteristic equation becomes  $s^3 + 2.89s^2 + 1.893s + 0.003 = 0$ . This equation has roots at  $s = -0.0016, -1, -1.884$ .

66.

a.

```
>> s=tf('s');
>> Ga=10.26/(s^2+11.31*s+127.9);
>> F=6.667e-5*s^2/(s^2+0.2287*s+817.3);
>> Gm=s/(s^2+5.181*s+22.18);
>> G=Ga*F*Gm;
```

>> sisotool

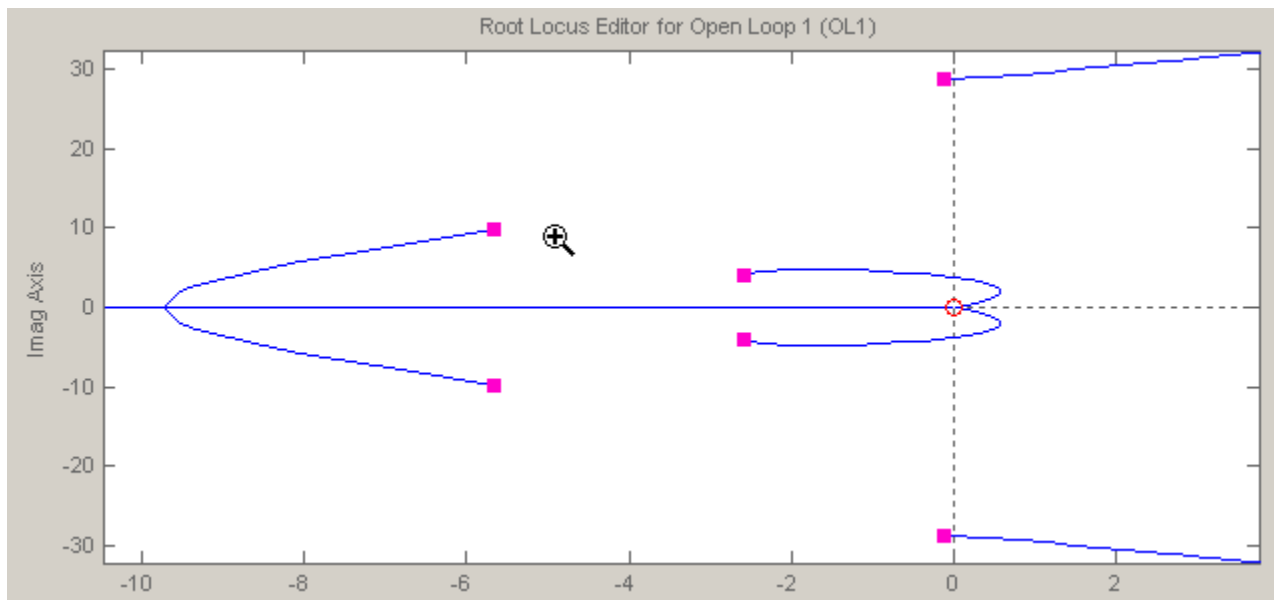

b. The system will be closed loop stable for  $0 < K < 3 \cdot 10^5$

c. The system cannot be overdamped because there will always be two undamped poles very close to the  $j\omega$  axis.

67.

a. The characteristic equation is given by:

$$1 + K \frac{s^4}{(s^2 + s + 1)^2} = 0$$

or

$$(1 + K)s^4 + 2s^3 + 3s^2 + 2s + 1 = 0$$

The Routh table is

$s^4$	$1+K$	3	1
$s^3$	2	2	
$s^2$	$2-K$	1	
$s$	$\frac{2(1-K)}{2-K}$		
1	1		

Clearly for closed loop stability  $K < 1$ .

**b.** There is no locus on the real axis, and no asymptotes. The root locus starts at the loci of the complex poles and ends at the zeros in the origin:

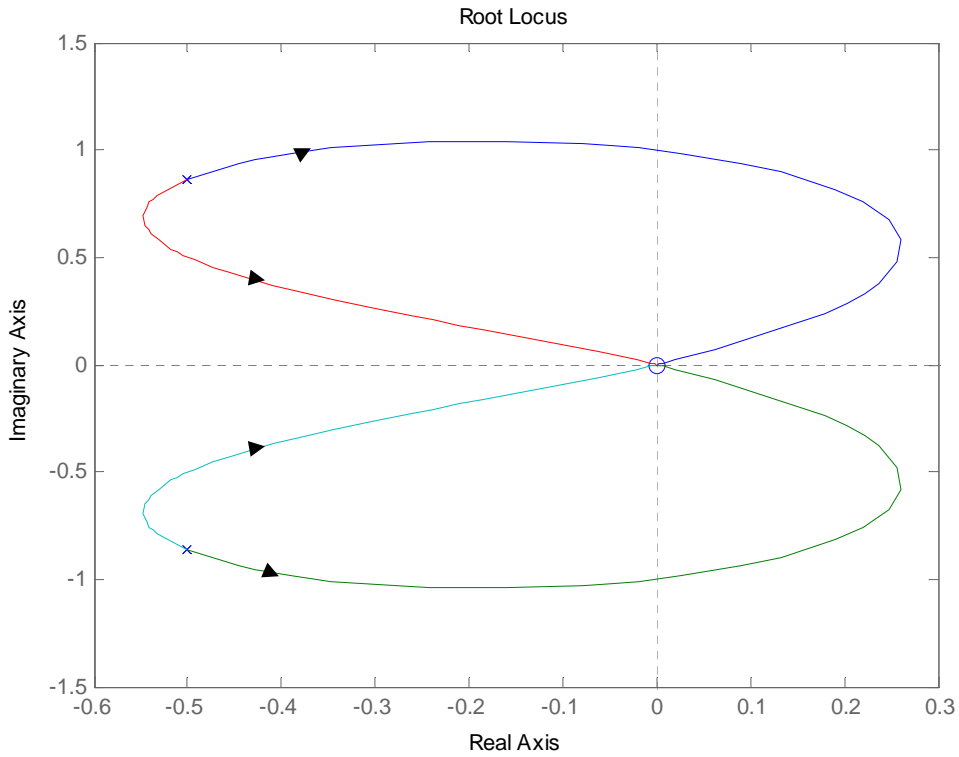



68.

a.

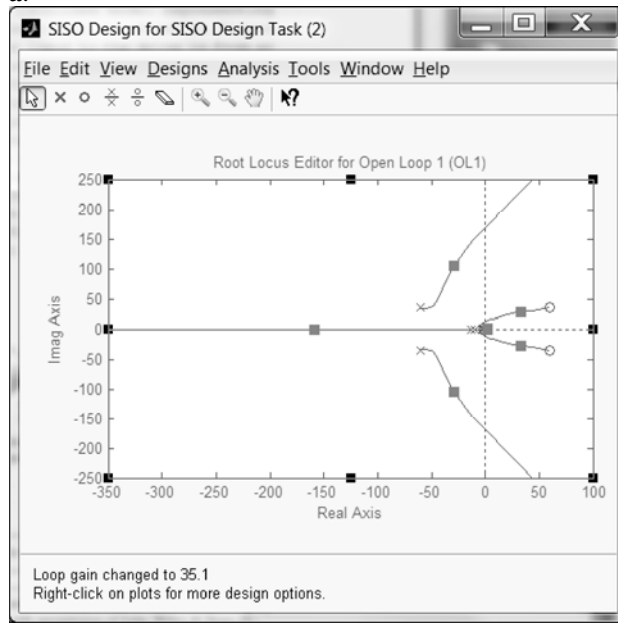

Close-up View

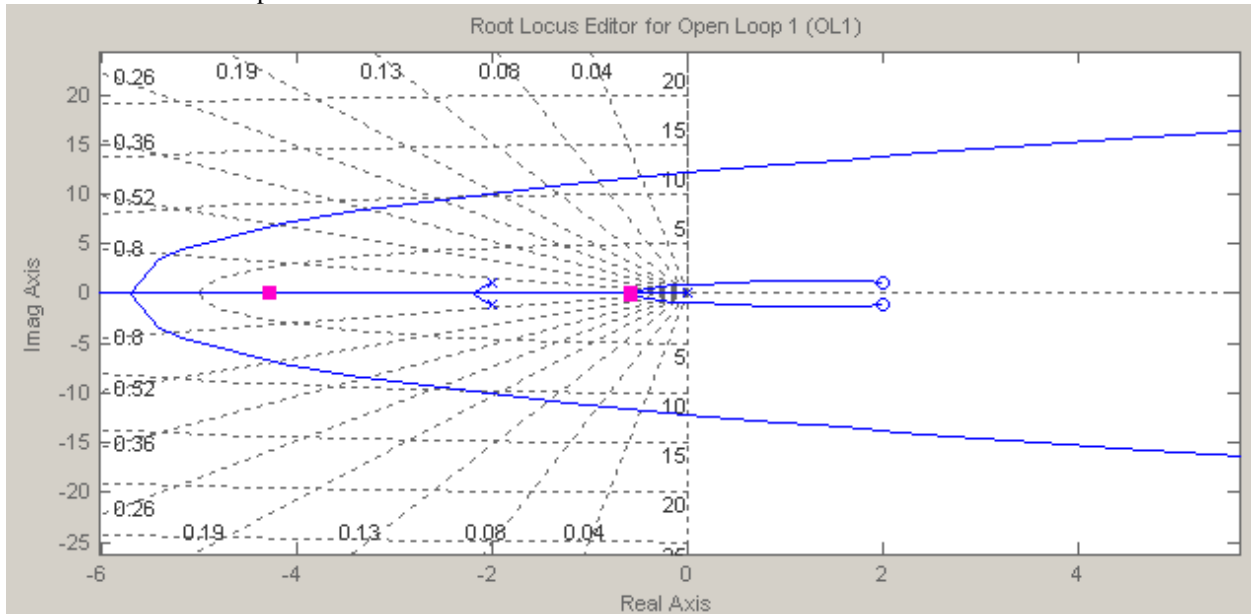

b. It can readily found that for closed loop stability  $0 < K < 0.0059$

c. The fastest response will be obtained when the closest poles to the  $j\omega$  axis are both real and identical. This will occur when  $K = 0.00136$

d. When  $K=0.00136$  the dominant poles are situated at  $-0.57$ . The settling time

$$T_s \approx \frac{4}{0.57} = 7.02 \text{ sec}$$

e. The actual settling time is 9.7 sec as shown in the figure below.

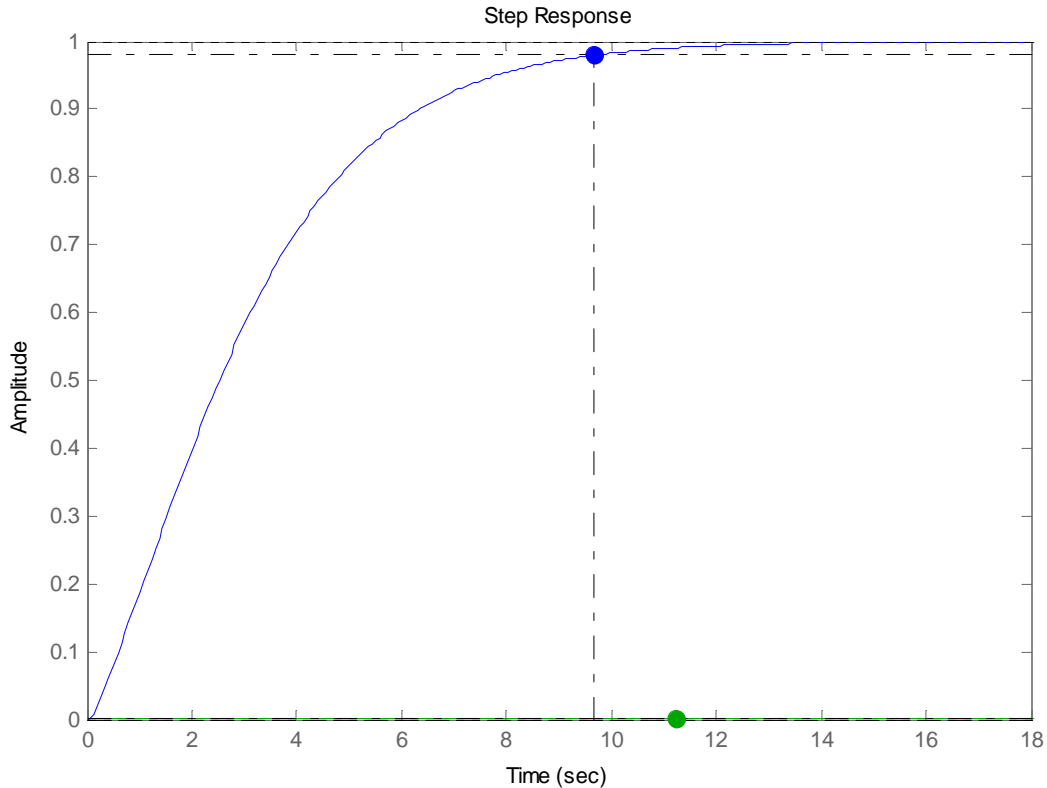

69.

```
% Parameters
Jl=10;Bl=1;k=100;Jm=2;Bm=0.5;a=0.25;% a is the location of the zero
% numerator and denominator of the open loop transfer function
numo=k*[1 a];
deno=[Jl*Jm (Jl*Bm+Jm*Bl) (k*(Jl+Jm)+Bl*Bm) k*(Bl+Bm) 0];
syso=tf(numo,deno);

% Pole-Zero map for the open loop transfer function
pzmap(syso);
% Root Locus
rlocus(syso);axis([-1 0 -0.3 0.3]);
zgrid(0.707,[]); % grid for zeta=0.707 for approx. 5% overshoot
[KD,poles]=rlocfind(syso);
% Choose the appropriate location of the poles in the window and multiply the factor by the open
loop
% transfer function
syso=KD*syso;
% Close the loop
sysc=feedback(syso,1);
```

```
figure;
%Obtain the response
step(sysc)
```

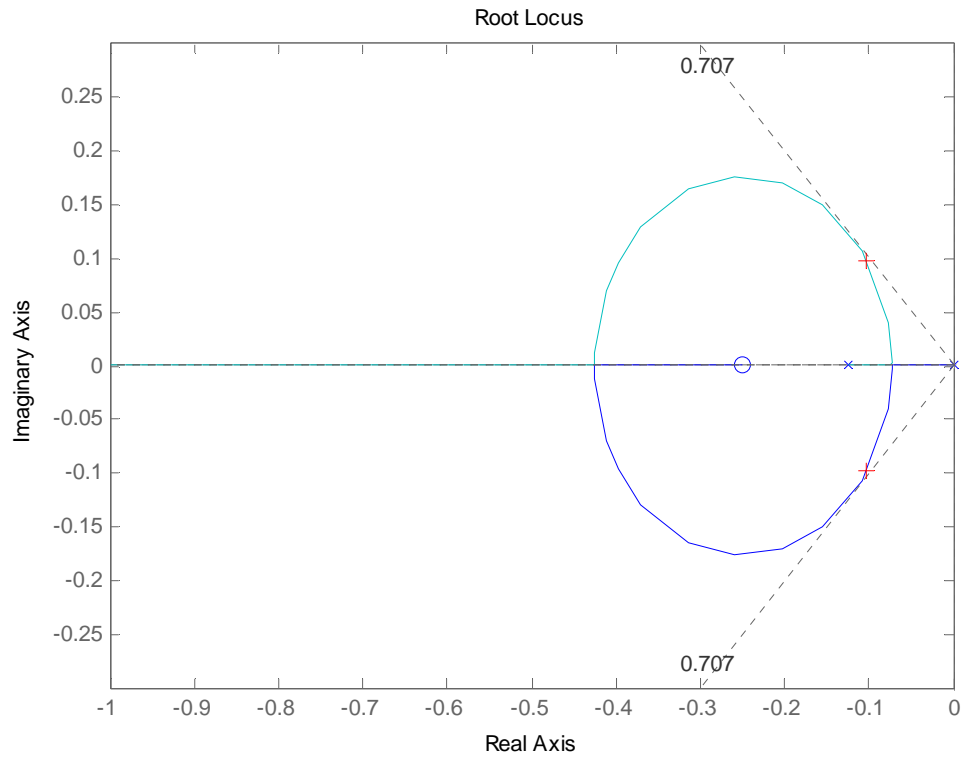

Select a point in the graphics window

selected\_point =

-0.1031 + 0.0978i

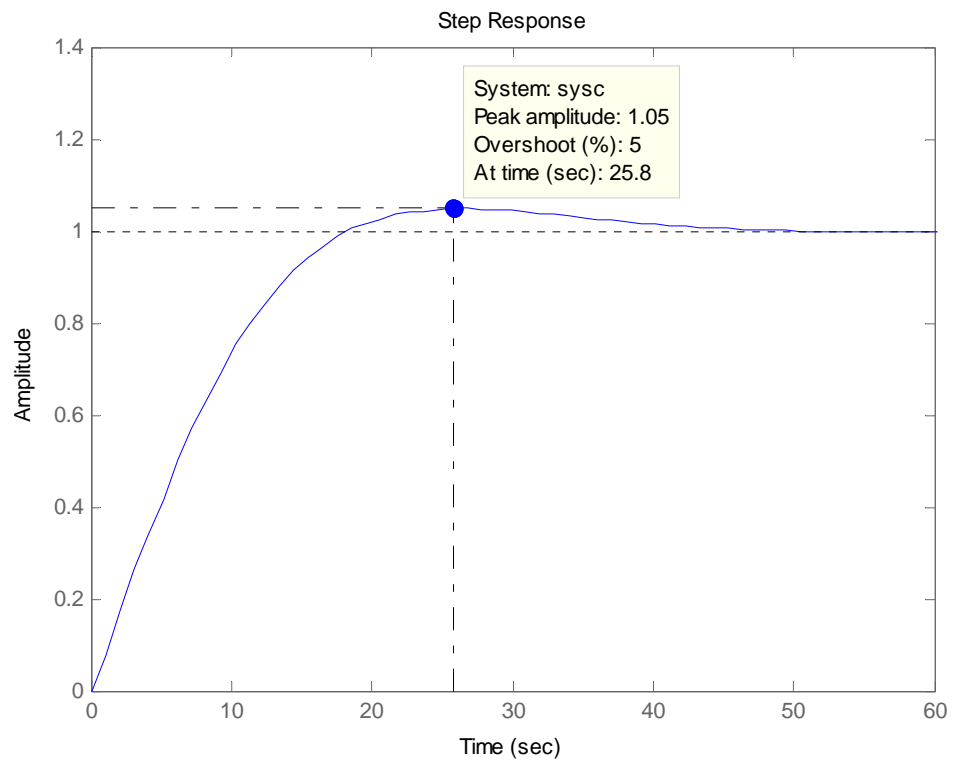

Note the 5 % overshoot specified.

70.

Front Panel

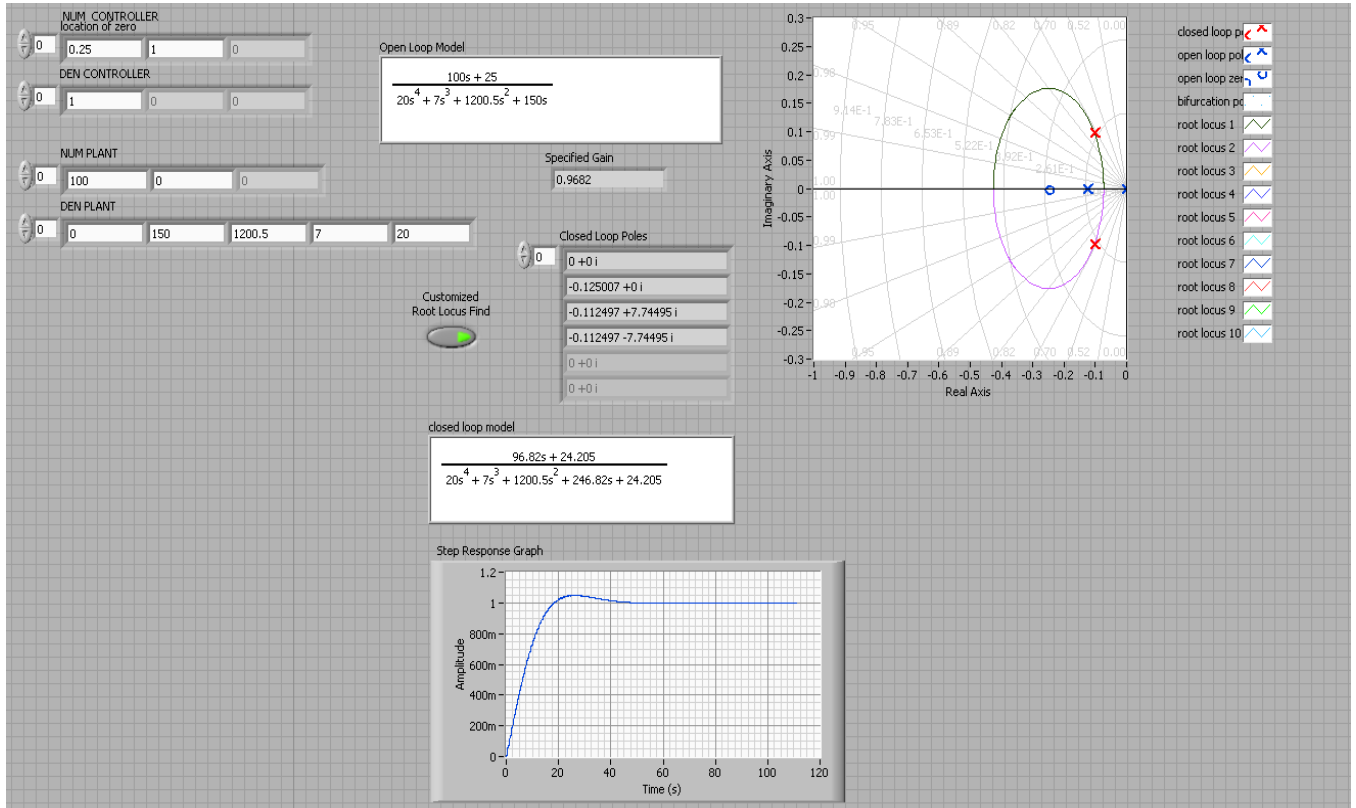

Block Diagram

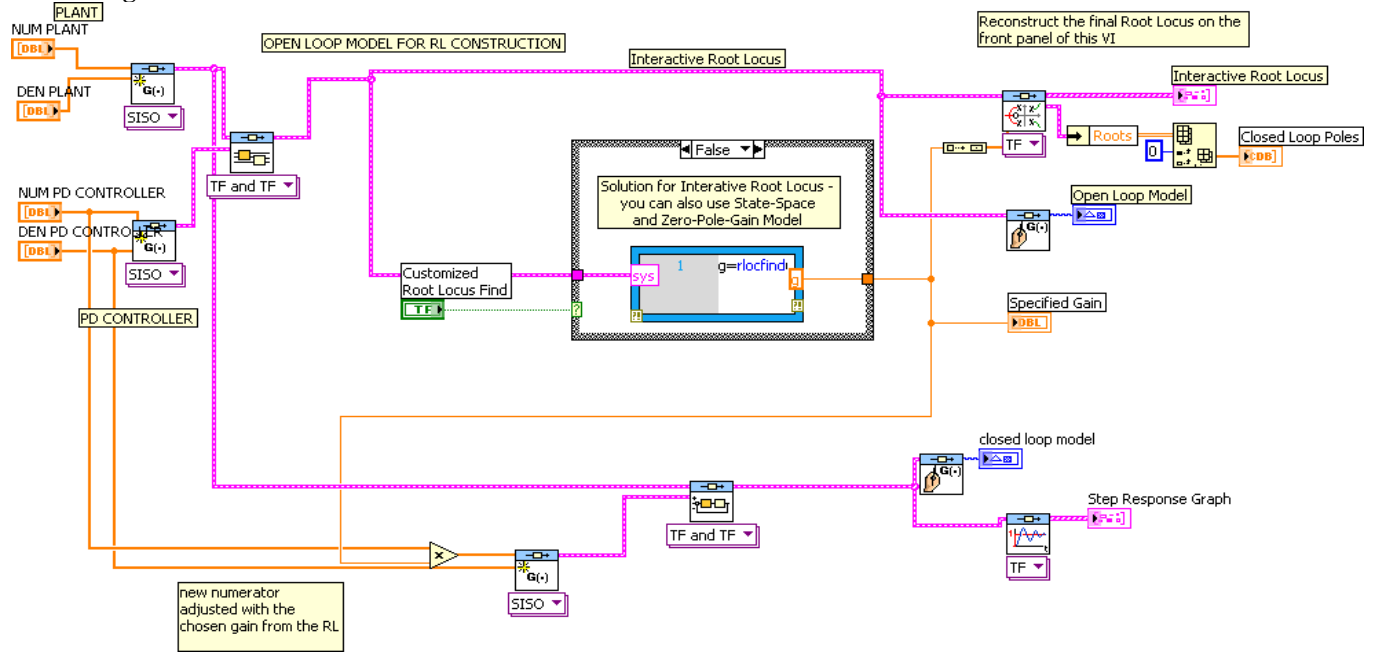

Details of the Case Structure

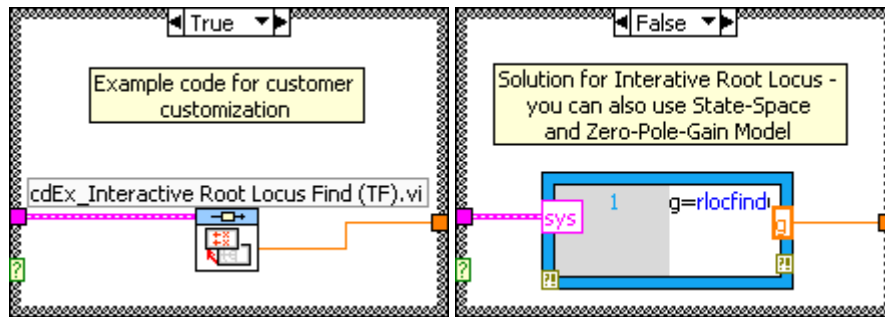

71.

The following MATLAB M-file was written to plot the root locus for the system and to find the required-above operational parameters and functions:

```

numg = poly([-0.071-6.25i -0.071+6.25i]);
deng = poly([-0.047 -2 -0.262+5.1i -0.262-5.1i]);
G = tf(numg, deng);
rlocus(G);
pos=(16);
z=-log(pos/100)/sqrt(pi^2+(log(pos/100))^2);
sgrid(z,0)
title(['Root Locus with ', num2str(pos), ' Percent Overshoot Line
for Synchronous Machine with Te = 0.5 sec'])
[K1,p]=rlocfind(G);
pause
K=0.936*K1;
T=feedback(K*G,1);      %T is the closed-loop TF of the system
T=minreal(T);
step(T);
grid

```

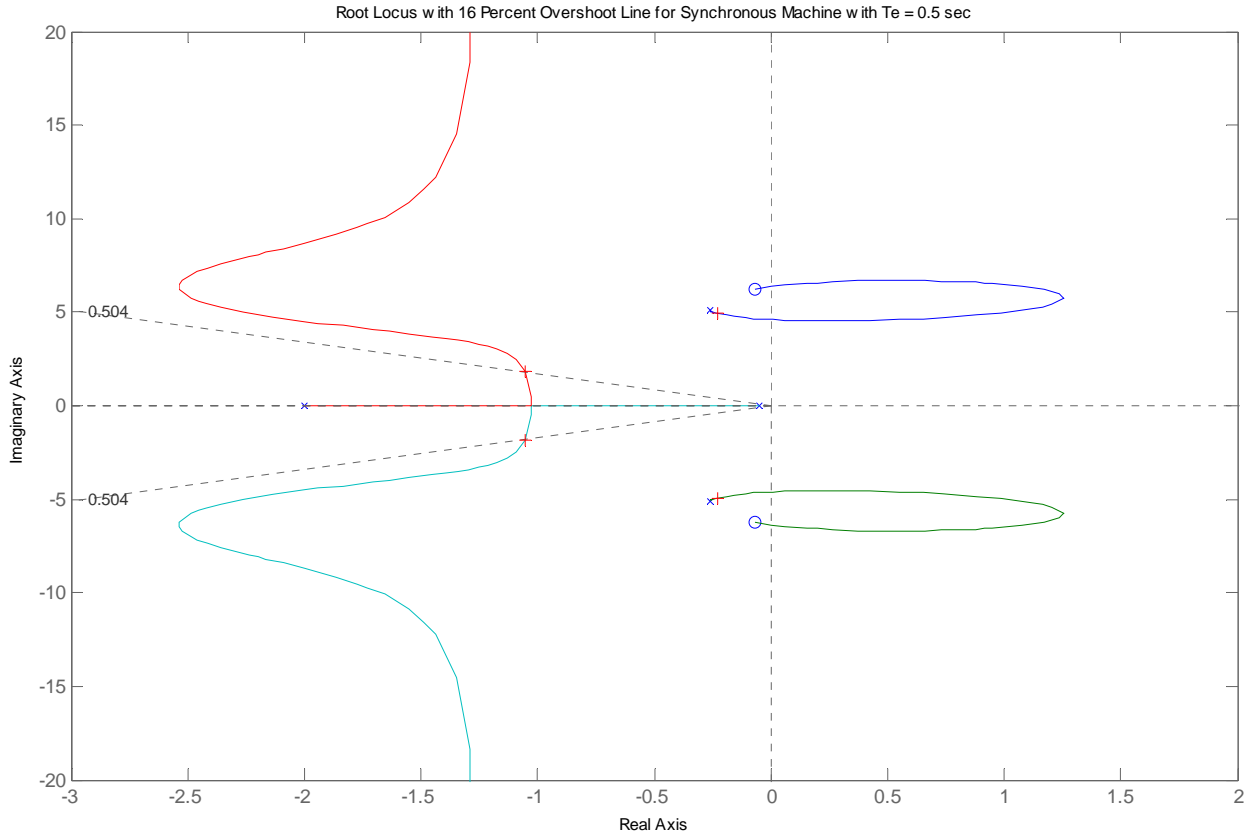

**Root Locus with 16% Overshoot Line for Synchronous Machine**

a. The gain at which the system becomes marginally stable is:

$$K = 7.1045$$

b. The closed-loop poles,  $p$ , and transfer function,  $T(s)$ , corresponding to a 16% overshoot are:

$$p = \begin{aligned} & -0.2300 + 4.9446i \\ & -0.2300 - 4.9446i \\ & -1.0555 + 1.8634i \\ & -1.0555 - 1.8634i \end{aligned}$$

$$T(s) = \frac{2.633 s^2 + 0.3739 s + 102.9}{s^4 + 2.571 s^3 + 29.88 s^2 + 53.81 s + 105.3}$$

- c. The coordinates of the point selected on the root-locus were:  $-1.0557 + 1.8634i$  and the corresponding unit-step response, with  $\delta(t)$  in p.u, was found.
- d. MATLAB was used to plot that unit-step response and to note on that curve the required characteristics:

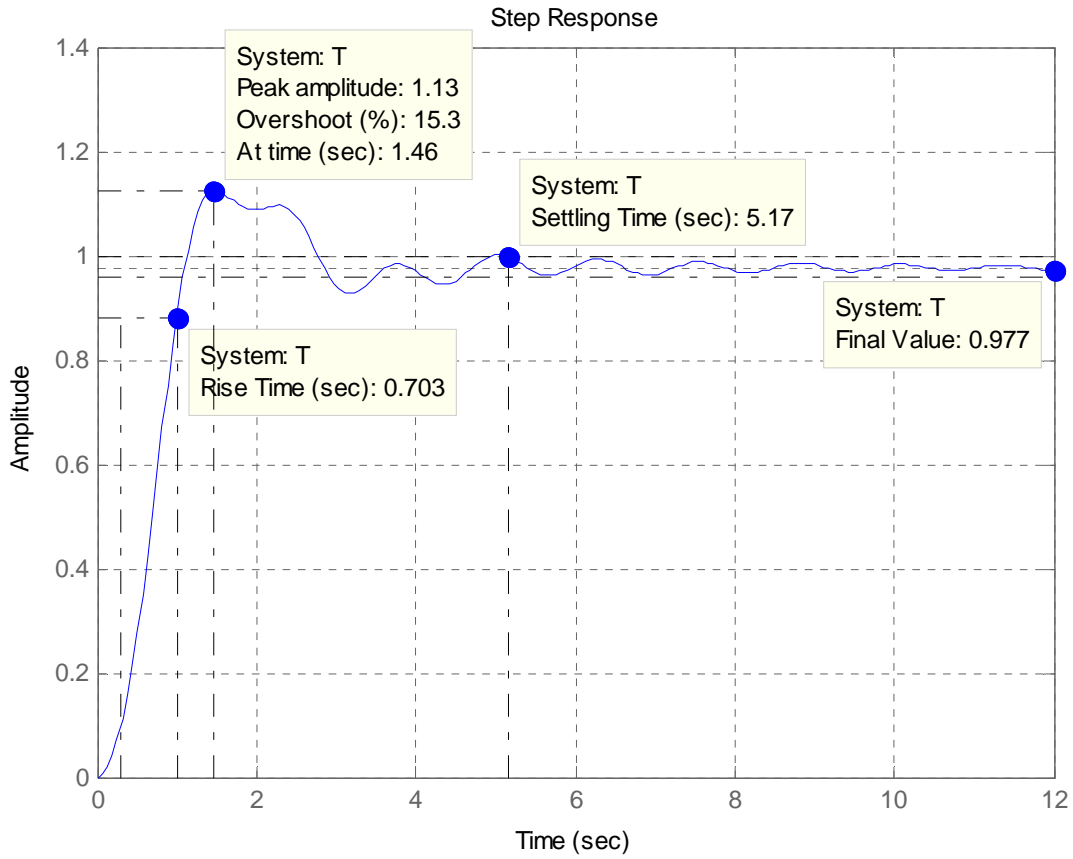



72. a.

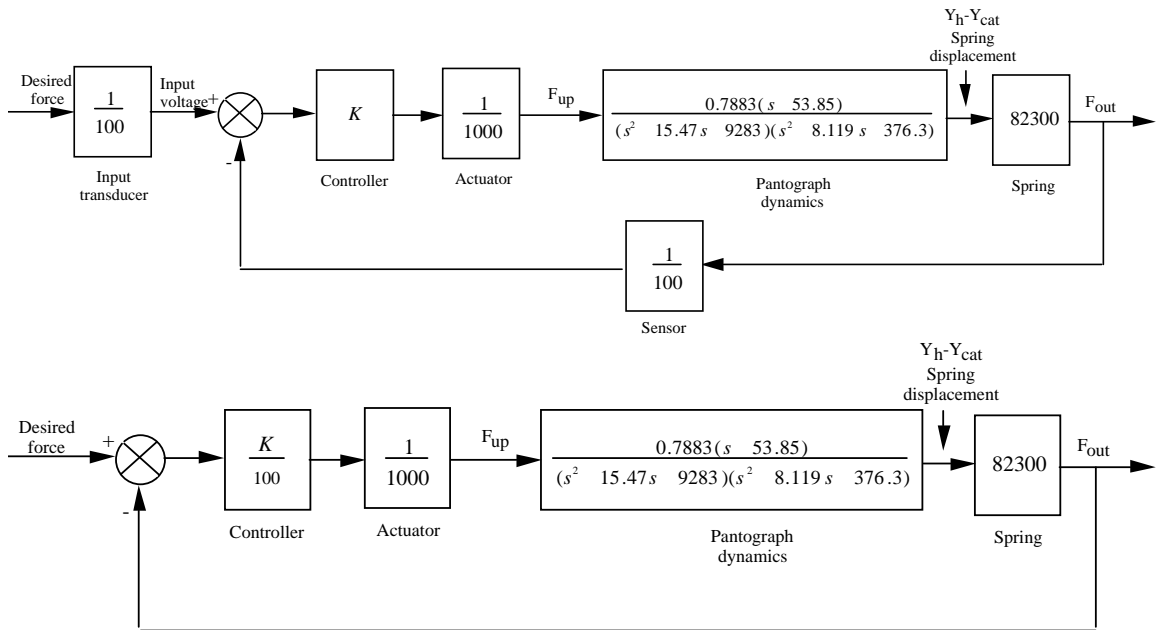

$$G(s) = \frac{Y_h(s) Y_{cat}(s)}{F_{up}(s)} = \frac{0.7883(s + 53.85)}{(s^2 + 15.47s + 9283)(s^2 + 8.119s + 376.3)}$$

$$G_e(s) = (K/100) * (1/1000) * G(s) * 82.3e3$$

$$G_e(s) = \frac{0.6488K(s + 53.85)}{(s^2 + 8.119s + 376.3)(s^2 + 15.47s + 9283)}$$

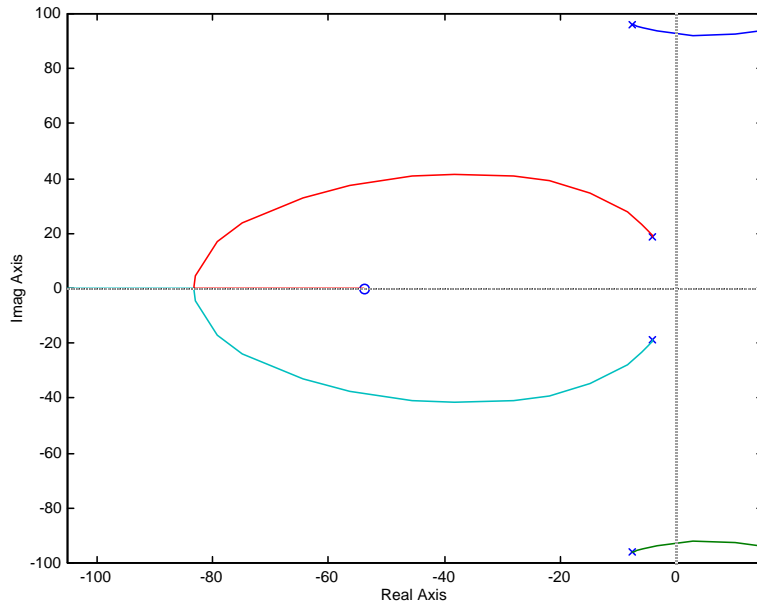

**b.** 38% overshoot yields  $\zeta = 0.294$ . The  $\zeta = 0.294$  line intersects the root locus at  $-9 + j27.16$ . Here,  $K_c = 7.179 \times 10^4$ . Thus  $K = K_c/0.6488$ , or  $K = 1.107 \times 10^5$ .

**c.**  $T_s = 4/\text{Re} = 4/9 = 0.44$  s;  $T_p = \pi/\text{Im} = \pi/27.16 = 0.116$  s

**d.** Nondominant closed-loop poles are located at  $-3.4 \pm j93.94$ . Thus poles are closer to the imaginary axis than the dominant poles. Second order approximation not valid.

**e.**

**Program:**

```
syms s
numg=(s+53.85);
deng=(s^2+15.47*s+9283)*(s^2+8.119*s+376.3);
numg=sym2poly(numg);
deng=sym2poly(deng);
G=tf(numg,deng)
K=7.179e4
Ke=0.6488*K
T=feedback(Ke*G,1)
step(T)
```

**Computer response:**

Transfer function:

$$\frac{s + 53.85}{s^4 + 23.59 s^3 + 9785 s^2 + 8.119e004 s + 3.493e006}$$

K =

71790

Ke =

4.6577e+004

Transfer function:

$$\frac{4.658e004 s + 2.508e006}{s^4 + 23.59 s^3 + 9785 s^2 + 1.278e005 s + 6.001e006}$$

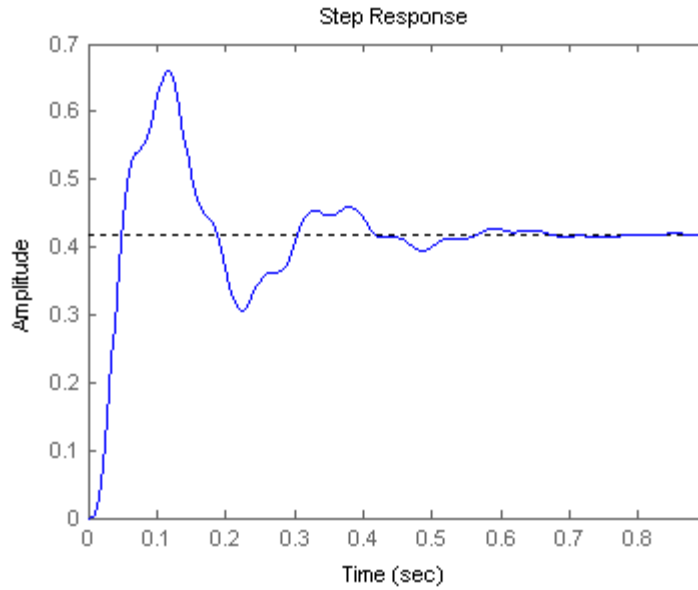

$$T_p = 0.12 \text{ s}, T_s = 0.6 \text{ s}, \%OS = \frac{0.66 - 0.42}{0.42} = 57.1\%$$

73.

a. The open loop transfer function is

$$KG(s)P(s) = -\frac{K(520s + 10.3844)}{s^3 + 2.6817s^2 + 0.11s + 0.0126}$$

$$= \frac{-520K(s + 0.02)}{(s + 0.02 + j0.0661)(s + 0.02 - j0.0661)(s + 2.6419)}$$

There are two asymptotes with a real axis intersection given by

$$\sigma_a = \frac{-2.6419 - 2(-0.02) - (-0.02)}{3-1} = -1.33 \text{ and angles } \theta_a = \frac{2\pi k}{2}. \text{ For } k=0, \theta_a = 0 \text{ and}$$

for  $k=1, \theta_a = \pi$ .

To obtain the breakaway points let

$$K = -\frac{1}{G(\sigma)H(\sigma)} = \frac{\sigma^3 + 2.6817\sigma^2 + 0.11\sigma + 0.0126}{520\sigma + 10.3844}$$

And calculate and solve

$$\begin{aligned}\frac{dK}{d\sigma} &= \frac{(520\sigma + 10.3844)(3\sigma^2 + 5.3634\sigma + 0.11) - 520(\sigma^3 + 2.6817\sigma^2 + 0.11\sigma + 0.0126)}{(520\sigma + 10.3844)^2} \\ &= \frac{1040\sigma^3 + 1426\sigma^2 + 55.7\sigma - 5.41}{(520\sigma + 10.3844)^2} = 0\end{aligned}$$

Giving  $\sigma = -1.33, -0.0879, 0.0446$  with only the latter in the root locus. The value of  $K$  at

$\sigma = 0.0446$  is given by:

$$K = \left. \frac{\sigma^3 + 2.6817\sigma^2 + 0.11\sigma + 0.0126}{520\sigma + 10.3844} \right|_{\sigma=0.0446} = 6.82 \times 10^{-4}$$

It was already found in Problem 6.2 That the system is closed loop stable for  $K < 2.04 \times 10^{-4}$ .

The root locus is:

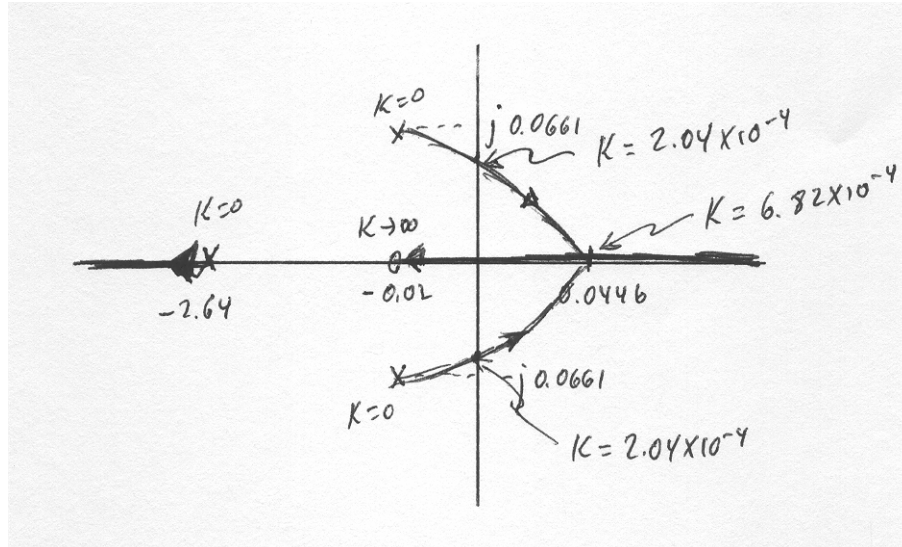

b. Now the open loop transfer function is:

$$\begin{aligned}KG(s)P(s) &= \frac{K(520s + 10.3844)}{s^3 + 2.6817s^2 + 0.11s + 0.0126} \\ &= \frac{520K(s + 0.02)}{(s + 0.02 + j0.0661)(s + 0.02 - j0.0661)(s + 2.6419)}\end{aligned}$$

There are two asymptotes with a real axis intersection as in part a. but with angles

$$\theta_a = \frac{(2k+1)\pi}{2}. \text{ For } k = 0, \theta_a = \frac{\pi}{2} \text{ and for } k = 1, \theta_a = \frac{3\pi}{2} = -\frac{\pi}{2}.$$

The breakaway point calculation is similar to the one in part a. giving

$$\sigma = -1.33, -0.0879, 0.0446 \text{ with the first two points in the root locus.}$$

The value of  $K$  at  $\sigma = -1.33$  is given by:

$$K = - \left. \frac{\sigma^3 + 2.6817\sigma^2 + 0.11\sigma + 0.0126}{520\sigma + 10.3844} \right|_{\sigma=-1.33} = 0.0033$$

The value of  $K$  at  $\sigma = -0.0879$  is given by:

$$K = - \left. \frac{\sigma^3 + 2.6817\sigma^2 + 0.11\sigma + 0.0126}{520\sigma + 10.3844} \right|_{\sigma=-0.0879} = 6.5 \times 10^{-4}$$

We use Routh-Hurwitz to show that the system is closed loop stable for all  $K > 0$ . The

characteristic equation is:

$$1 + K \frac{520s + 10.3844}{s^3 + 2.6817s^2 + 0.11s + 0.0126} = 0$$

or

$$s^3 + 2.6817s^2 + 0.11s + 0.0126 + K(520s + 10.3844) = 0$$

or

$$s^3 + 2.6817s^2 + (0.11 + 520K)s + (0.0126 + 10.3844K) = 0$$

The Routh Array is:

$s^3$	1	$0.11 + 520K$
$s^2$	2.6817	$0.0126 + 10.3844K$
$s$	$\frac{0.2824 + 1384.1K}{2.6817}$	
1	$0.0126 + 10.3844K$	

It can easily be verified that all the entries in the first column are positive for all  $K > 0$ .

The root locus is:

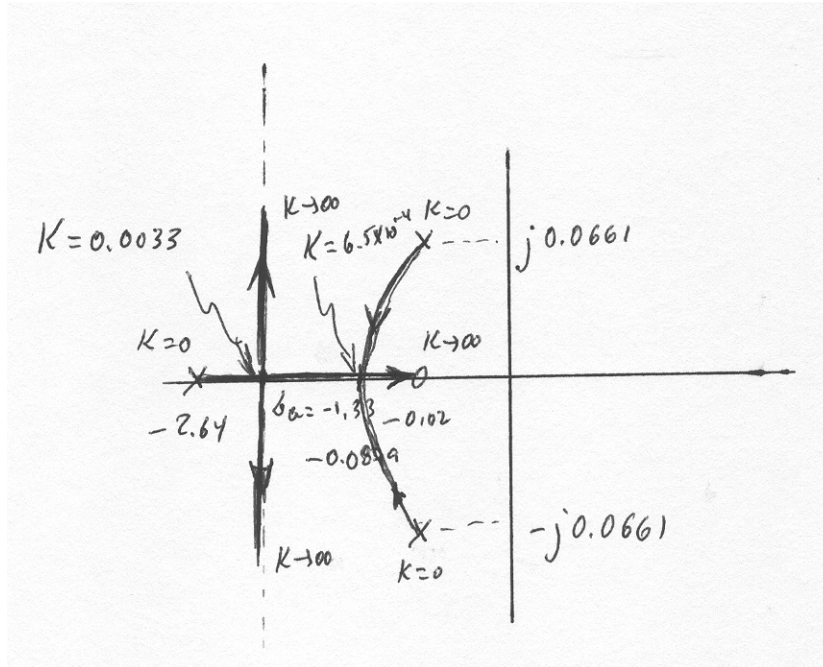

74.

a. With the speed controller configured as a proportional controller [ $K_{isc} = 0$  and  $G_{sc}(s) = K_{psc}$ ], the open-loop transfer function is:  $G_{sc}(s)G_v(s) = \frac{0.11K_{psc}(s+0.6)}{s(s+0.5173)+5(s+0.6)(s+0.01908)}$ .

Expanding the denominator of this transfer function, gives:

$$D_G(s) = 6s^2 + 3.613s + 0.05724.$$

Solving for the roots shows that there are two open-loop poles:  $-0.5858$  and  $-0.0163$ . Thus, the open-loop transfer function may be re-written as:

$$G_{sc}(s)G_v(s) = \frac{0.11K_{psc}(s+0.6)}{6s^2 + 3.613s + 0.05724} = \frac{K_1(s+0.6)}{(s+0.5858)(s+0.0163)} \quad (1)$$

$$\text{In this equation: } K_1 = \frac{K_{psc} \times 0.11}{6} \quad (2)$$

The following MATLAB M-file was written to plot the root locus for the system and to find the value of the proportional gain,  $K_p$ , at the breakaway or break-in points.

```

numg = [1 0.6];
deng = poly ([-0.0163 -0.5858]);
G = tf(numg, deng);
rlocus(G);
pos=(0);
z=-log(pos/100)/sqrt(pi^2+(log(pos/100))^2);
sgrid(z,0)
title(['Root Locus with ', num2str(pos) , ' Percent Overshoot
Line'])
[K1,p]=rlocfind(G);
pause
T=feedback(K1*G,1);      %T is the closed-loop TF of the system
T=minreal(T);
step(T);
axis ([0, 8, 0, 1]);
grid

```

The root locus shown below was obtained. Using MATLAB tools, the gain at the break-in point was found to be larger and, hence, would yield a faster closed-loop unit-step response. The following repeated real poles were found, which indicated that the step response is critically damped:  $p = -0.6910, -0.6910$ . These poles corresponded to:  $K_1 = 0.78$  (which corresponds to  $K_{pSC} = 42.54$ ). The closed-loop transfer function,  $T(s)$ , was found to be:

$$T(s) = \frac{0.78s + 0.468}{s^2 + 1.382s + 0.4775}$$

Therefore, it was used to find the closed-loop transfer function of the system, to plot its unit-step response,  $c(t)$ , shown below, and to find the rise-time,  $T_r$ , and settling time,  $T_s$ .

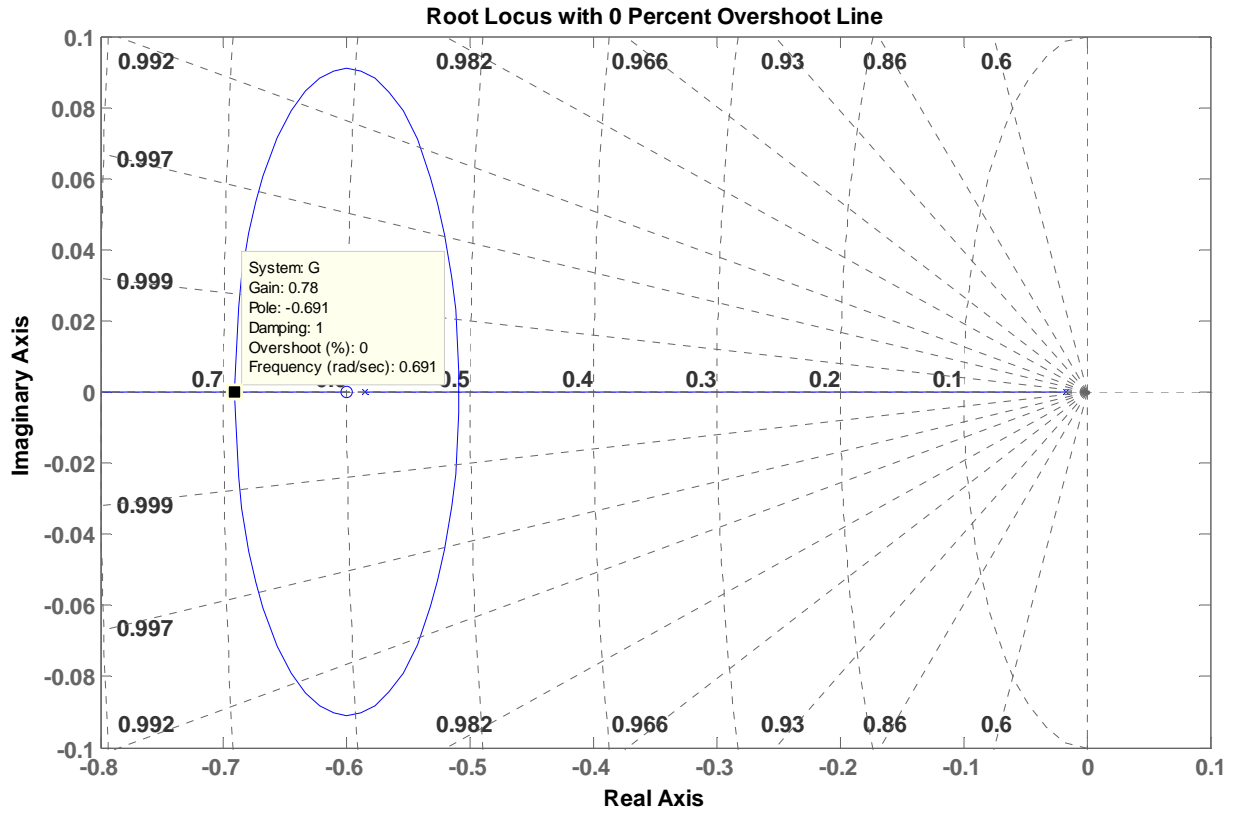



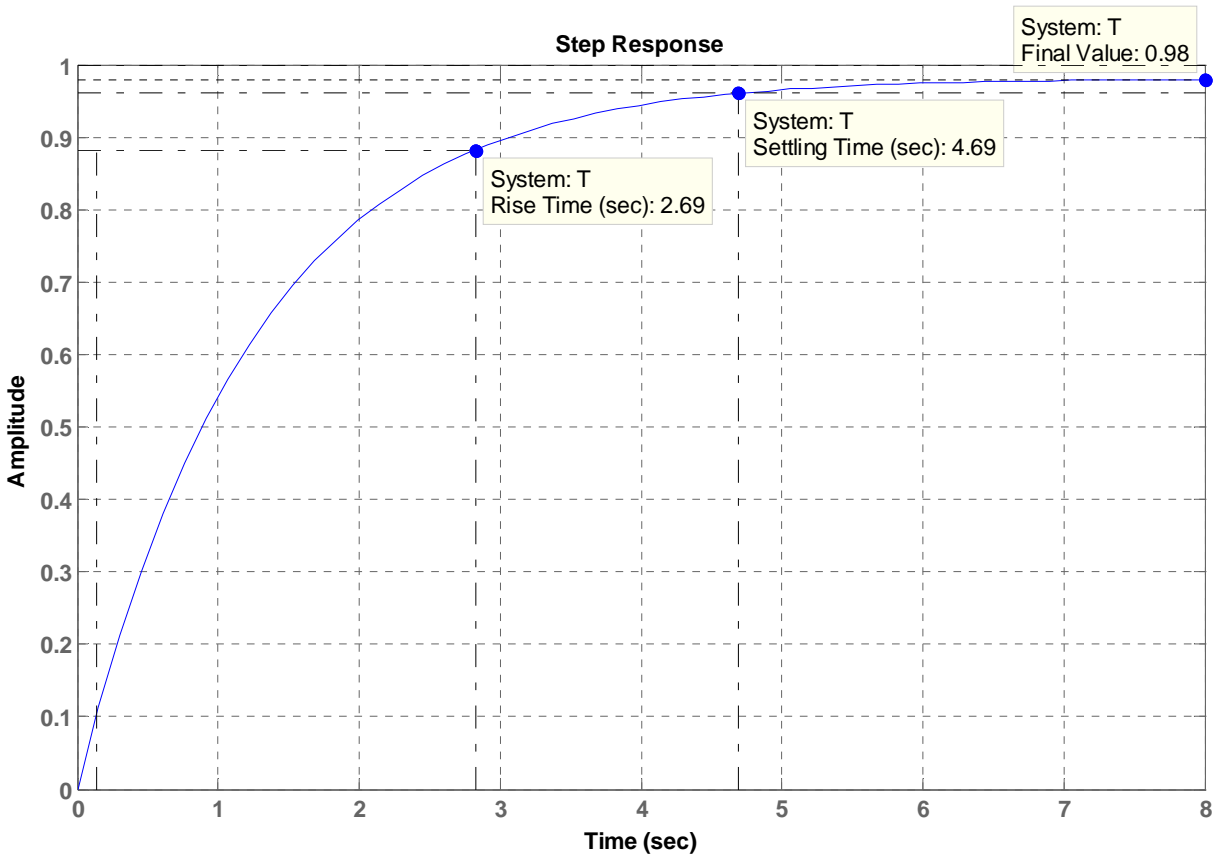

As could be seen from the graph, these times are:

$$T_r = 2.69 \text{ sec and } T_s = 4.69 \text{ sec}$$

**b.** When integral action was added (with  $K_{Isc}/K_{psc} = 0.4$ ), the transfer function of the speed controller became:  $G_{SC}(s) = K_{psc} + \frac{K_{Isc}}{s} = \frac{K_{psc}(s+0.4)}{s}$  and the open-loop transfer function obtained is:

$$G_{sc}(s)G_v(s) = \frac{0.11K_{psc}(s+0.6)(s+0.4)}{s(6s^2 + 3.613s + 0.05724)} = \frac{K_1(s+0.6)(s+0.4)}{s(s+0.5858)(s+0.0163)}$$

$$\text{Where } K_1 = \frac{0.11K_{psc}}{6} \text{ or } K_{psc} = \frac{6K_1}{0.11} = 54.5455 K_1$$

The following MATLAB M-file was written to plot the root locus for the system and to find the gain,  $K_1$ , which could result in a closed-loop unit-step response with 10% overshoot.

```

numg = poly ([-0.4 -0.6]);
deng = poly ([0 -0.0163 -0.5858]);
G = tf(numg, deng);
rlocus(G);
pos=(10);
z=-log(pos/100)/sqrt(pi^2+(log(pos/100))^2);
axis ([-1, 0, -0.5, 0.5]);
sgrid(z,0)
title(['Root Locus with ', num2str(pos) , ' Percent Overshoot
Line'])
[K1,p]=rlocfind(G);
pause
T=feedback(K1*G,1);      %T is the closed-loop TF of the system
T=minreal(T);
step(T);
axis ([0, 20, 0, 1.5]);
grid

```

The root locus shown below was obtained. Using MATLAB tools, the gain at the point selected on the locus ( $-0.275 + j0.376$ ) was found to be  $K_1 = 0.526$  (which corresponds to  $K_{pSC} = 28.7$ ). The corresponding closed-loop transfer function,  $T(s)$ , is:

$$T(s) = \frac{0.526 s^2 + 0.526 s + 0.1262}{s^3 + 1.128 s^2 + 0.5355 s + 0.1262}$$

$T(s)$  has the closed-loop poles:  $p = -0.580, -0.275 \pm j0.376$  and zeros at  $-0.4$  &  $-0.6$ . Thus, the complex conjugate poles are not dominant, and hence, the output response,  $c(t)$ , obtained using

MATLAB, does not match that of a second-order underdamped system. Note also that the settling time,  $T_s = 15$  sec, , the rise time,  $T_r = 2$  sec, the peak time,  $T_p = 5.03$  sec, and the overshoot is 24.5% (higher than the 10% corresponding to the dominant poles).

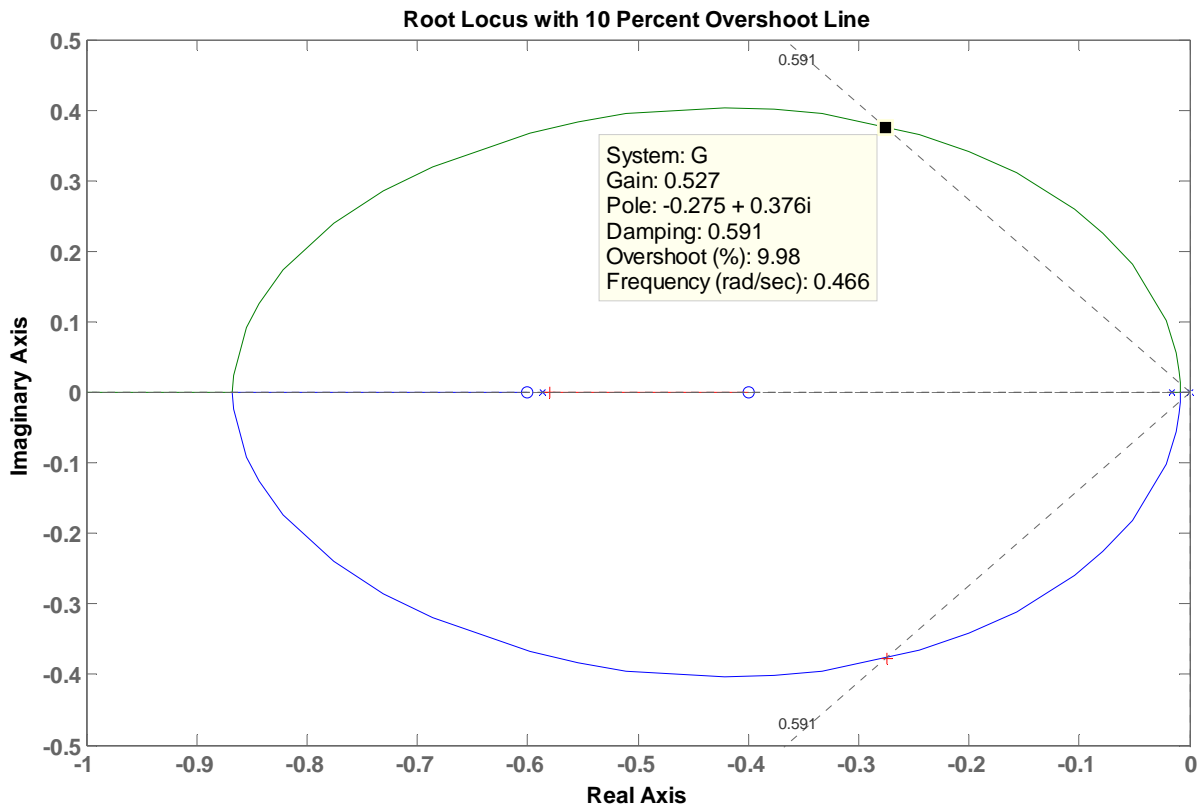

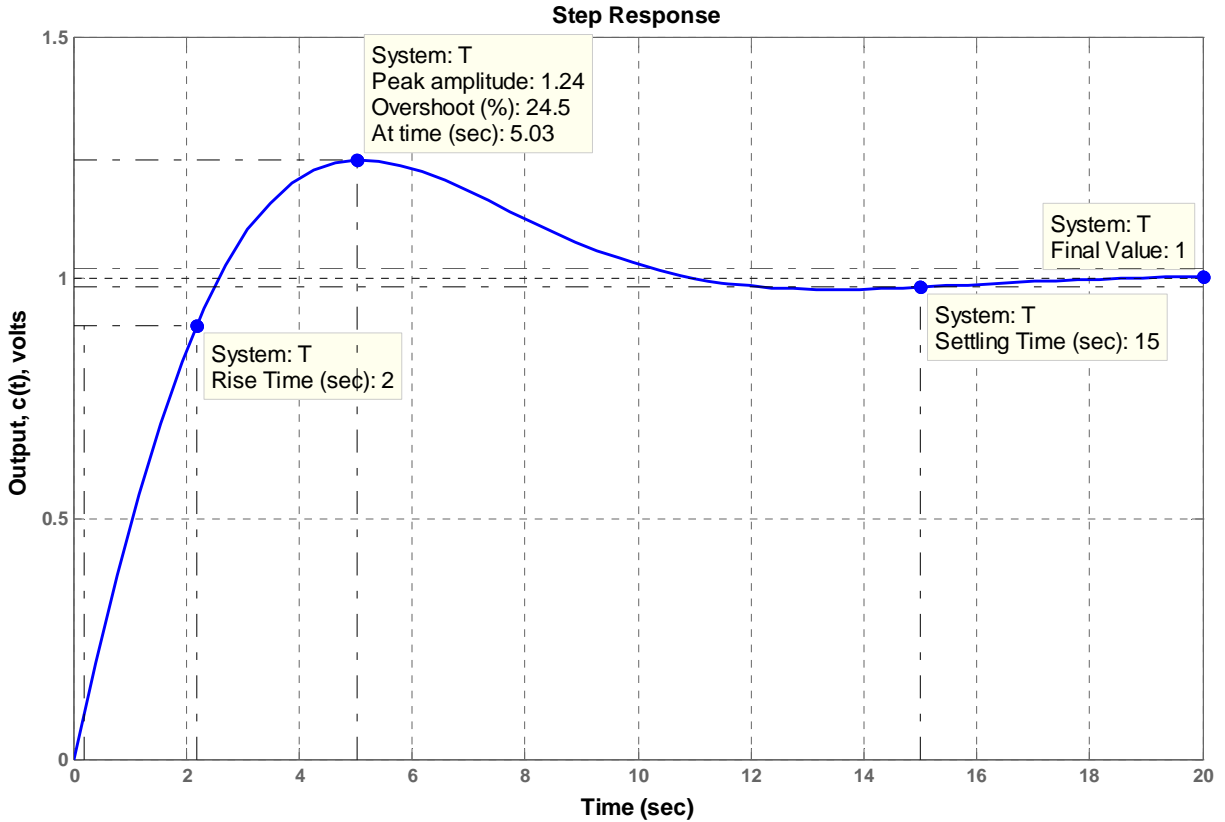

It should be mentioned that since we applied 1 volt-unit-step inputs (as compared to 4 volts in the Hybrid vehicle progressive problem in Chapter 5) in both parts (a) and (b) above, we should not be surprised that the final (steady-state) value of output voltage of the speed transducer was 1 volt, which corresponds to a change in car speed of only 5 km/hr.

# N I N E

## Design via Root Locus

### SOLUTIONS TO CASE STUDIES CHALLENGES

#### Antenna Control: Lag-Lead Compensation

a. Uncompensated: From the Chapter 8 Case Study Challenge,  $G(s) = \frac{76.39K}{s(s+150)(s+1.32)}$  =  $\frac{7194.23}{s(s+150)(s+1.32)}$  with the dominant poles at  $-0.5 \pm j6.9$ . Hence,  $\zeta = \cos(\tan^{-1} \frac{6.9}{0.5}) = 0.0723$ , or %OS = 79.63% and  $T_s = \frac{4}{\zeta\omega_n} = \frac{4}{0.5} = 8$  seconds. Also,  $K_v = \frac{7194.23}{150 \times 1.32} = 36.33$ .

b. Lead-Compensated: Reducing the percent overshoot by a factor of 4 yields, %OS =  $\frac{79.63}{4} = 19.91\%$ , or  $\zeta = 0.457$ . Reducing the settling time by a factor of 2 yields,  $T_s = \frac{8}{2} = 4$ . Improving  $K_v$  by 2 yields  $K_v = 72.66$ . Using  $T_s = \frac{4}{\zeta\omega_n} = 4$ ,  $\zeta\omega_n = 1$ , from which  $\omega_n = 2.188$  rad/s. Thus, the design point equals  $-\zeta\omega_n + j\omega_n\sqrt{1-\zeta^2} = -1 + j1.946$ . Using the system's original poles and assuming a lead compensator zero at  $-1.5$ , the summation of the system's poles and the lead compensator zero to the design point is  $-123.017^\circ$ . Thus, the compensator pole must contribute  $123.017^\circ - 180^\circ = -56.98^\circ$ . Using the geometry below,  $\frac{1.946}{p_c - 1} = \tan 56.98^\circ$ , or  $p_c = 2.26$ .

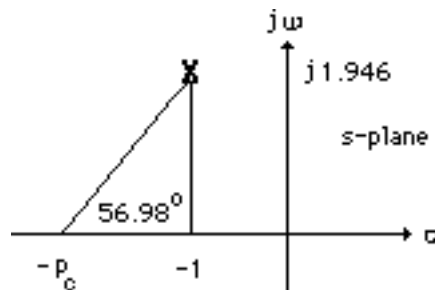

Adding this pole to the system poles and the compensator zero yields  $76.39K = 741.88$  at  $-1+j1.946$ . Hence the lead-compensated open-loop transfer function is  $G_{\text{Lead-comp}}(s) =$

$\frac{741.88(s+1.5)}{s(s+150)(s+1.32)(s+2.26)}$ . Searching the real axis segments of the root locus yields higher-order

poles at greater than -150 and at -1.55. The response should be simulated since there may not be pole/zero cancellation. The lead-compensated step response is shown below.

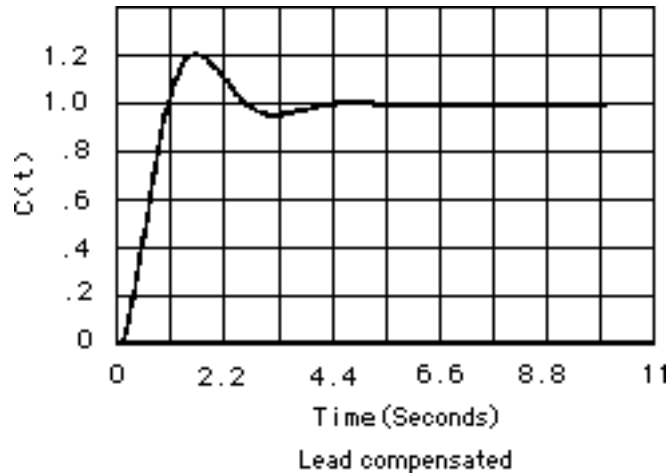

Since the settling time and percent overshoot meet the transient requirements, proceed with the lag

compensator. The lead-compensated system has  $K_v = \frac{741.88 \times 1.5}{150 \times 1.32 \times 2.26} = 2.487$ . Since we want  $K_v$

$= 72.66$ , an improvement of  $\frac{72.66}{2.487} = 29.22$  is required. Select  $G(s)_{Lag} = \frac{s+0.002922}{s+0.0001}$  to improve the steady-state error by 29.22. A simulation of the lag-lead compensated system,

$G_{Lag-lead-comp}(s) = \frac{741.88(s+1.5)(s+0.002922)}{s(s+150)(s+1.32)(s+2.26)(s+0.0001)}$  is shown below.

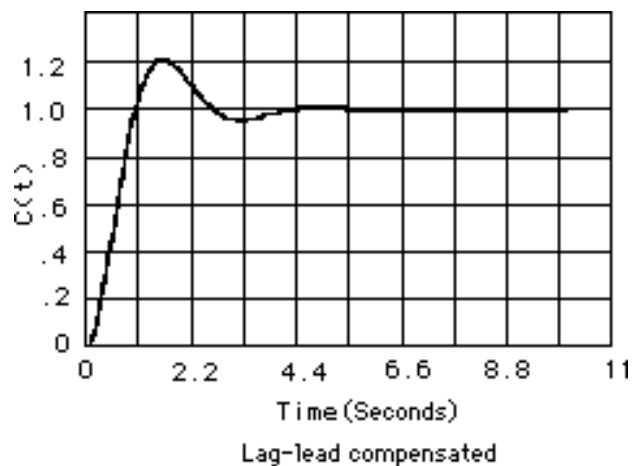

**UFSS Vehicle: Lead and Feedback Compensation**

Minor loop: Open-loop transfer function  $G(s)H(s) = \frac{0.25K_2(s+0.437)}{(s+2)(s+1.29)(s+0.193)}$  ; Closed-loop transfer

function:  $T_{ML}(s) = \frac{0.25K_2(s+0.437)}{s(s^3 + \dots)}$ . Searching along the  $126.87^\circ$  line ( $\zeta = 0.6$ ), find the

dominant second-order poles at  $-1.554 \pm j2.072$  with  $0.25K_2 = 4.7$ . Thus  $K_2 = 18.8$ . Searching the real axis segment of the root locus for a gain of 4.7 yields a 3rd pole at  $-0.379$ .

Major loop: The unity feedback, open-loop transfer function found by using the minor-loop closed-

loop poles is  $G_{ML}(s) = \frac{-0.25K_1(s+0.437)}{s(s+0.379)(s+1.554+j2.072)(s+1.554-j2.072)}$ . Searching along the  $120^\circ$  line

( $\zeta = 0.5$ ), find the dominant second-order poles at  $-1.069 \pm j1.85$  with  $0.25K_1 = 4.55$ . Thus  $K_1 = 18.2$ .

Searching the real axis segment of the root locus for a gain of 4.55 yields a 3rd pole at  $-0.53$  and a 4th pole at  $-0.815$ .

**ANSWERS TO REVIEW QUESTIONS**

1. Chapter 8: Design via gain adjustment. Chapter 9: Design via cascaded or feedback filters
2. A. Permits design for transient responses not on original root locus and unattainable through simple gain adjustments. B. Transient response and steady-state error specifications can be met separately and independently without the need for tradeoffs
3. PI or lag compensation
4. PD or lead compensation
5. PID or lag-lead compensation
6. A pole is placed on or near the origin to increase or nearly increase the system type, and the zero is placed near the pole in order not to change the transient response.
7. The zero is placed closer to the imaginary axis than the pole. The total contribution of the pole and zero along with the previous poles and zeros must yield  $180^\circ$  at the design point. Placing the zero closer to the imaginary axis tends to speed up a slow response.
8. A PD controller yields a single zero, while a lead network yields a zero and a pole. The zero is closer to the imaginary axis.
9. Further out along the same radial line drawn from the origin to the uncompensated poles
10. The PI controller places a pole right at the origin, thus increasing the system type and driving the error to zero. A lag network places the pole only close to the origin yielding improvement but no zero error.
11. The transient response is approximately the same as the uncompensated system, except after the original settling time has passed. A slow movement toward the new final value is noticed.

12. 25 times; the improvement equals the ratio of the zero location to the pole location.
13. No; the feedback compensator's zero is not a zero of the closed-loop system.
14. A. Response of inner loops can be separately designed; B. Faster responses possible; C. Amplification may not be necessary since signal goes from high amplitude to low.

## SOLUTIONS TO PROBLEMS

1.

Uncompensated system: Search along the  $\zeta = 0.5$  line and find the operating point is at  $-1.5356 \pm j2.6598$  with  $K = 73.09$ . Hence,  $\%OS = e^{-\zeta\pi / \sqrt{1-\zeta^2}} \times 100 = 16.3\%$ ;  $T_s = \frac{4}{1.5356} = 2.6$  seconds;  $K_p = \frac{73.09}{30} = 2.44$ . A higher-order pole is located at  $-10.9285$ .

Compensated: Add a pole at the origin and a zero at  $-0.1$  to form a PI controller. Search along the  $\zeta = 0.5$  line and find the operating point is at  $-1.5072 \pm j2.6106$  with  $K = 72.23$ . Hence, the estimated performance specifications for the compensated system are:  $\%OS = e^{-\zeta\pi / \sqrt{1-\zeta^2}} \times 100 = 16.3\%$ ;  $T_s = \frac{4}{1.5072} = 2.65$  seconds;  $K_p = \infty$ . Higher-order poles are located at  $-0.0728$  and  $-10.9125$ . The compensated system should be simulated to ensure effective pole/zero cancellation.

2.

a. Insert a cascade compensator, such as  $G_c(s) = \frac{s + 0.01}{s}$ .

b.

**Program:**

```
K=1
G1=zpk([], [0, -3, -6], K)    %G1=1/s(s+3)(s+6)
Gc=zpk([-0.01], [0], 1)     %Gc=(s+0.01)/s
G=G1*Gc
rlocus(G)
T=feedback(G, 1)
T1=tf(1, [1, 0])           %Form 1/s to integrate step input
T2=T*T1
t=0:0.1:200;
step(T1, T2, t)           %Show input ramp and ramp response
```

**Computer response:**

$K =$

1



Zero/pole/gain:  
 $\frac{1}{s(s+3)(s+6)}$

Zero/pole/gain:  
 $\frac{(s+0.01)}{s}$

Zero/pole/gain:  
 $\frac{(s+0.01)}{s^2(s+3)(s+6)}$

Zero/pole/gain:  
 $\frac{(s+0.01)}{(s+6.054)(s+2.889)(s+0.04384)(s+0.01304)}$

Transfer function:  
 $\frac{1}{s}$

Zero/pole/gain:  
 $\frac{(s+0.01)}{s(s+6.054)(s+2.889)(s+0.04384)(s+0.01304)}$

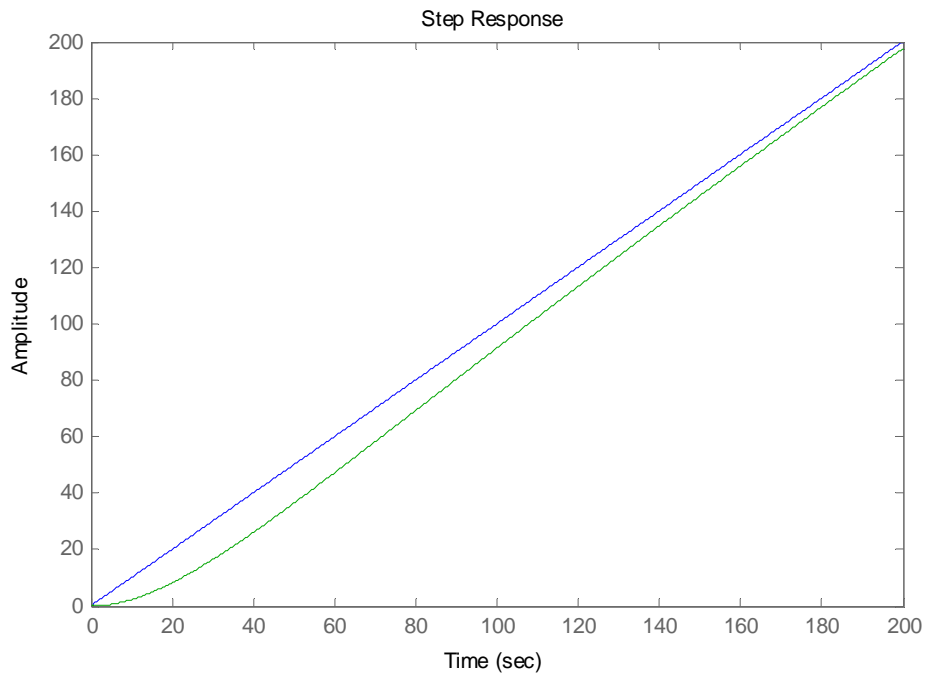

3.

a. Searching along the  $126.16^\circ$  line (10% overshoot,  $\zeta = 0.59$ ), find the operating point at

$$-1.8731 + j2.5633 \text{ with } K = 41.1905. \text{ Hence, } K_p = \frac{41.1905}{2 * 3 * 7} = 0.9807$$

b. A 4.0787 x improvement will yield  $K_p = 4$ . Use a lag compensator,  $G_c(s) = \frac{s + 0.40787}{s + 0.1}$ .

c.

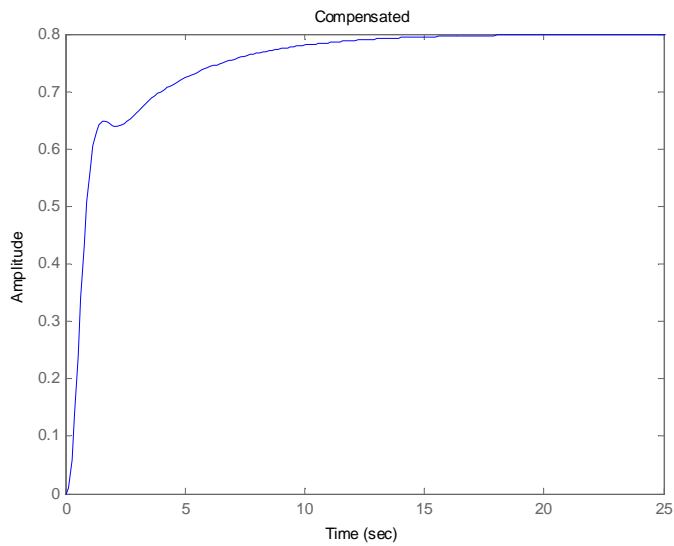
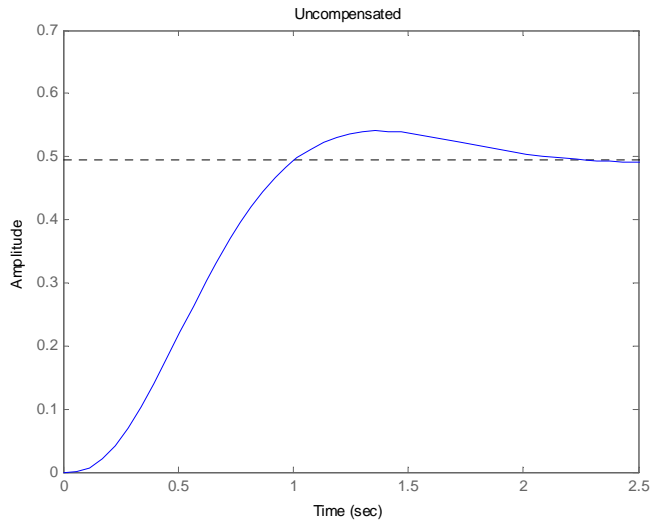

4.

a. Searching along the  $126.16^\circ$  line (10% overshoot,  $\zeta = 0.59$ ), find the operating point at

$$-1.1207 + j1.5336 \text{ with } K = 27.9948. \text{ Hence, } K_v = \frac{27.9948}{3 \times 7} = 1.3331.$$

b. A 3.0006 x improvement will yield  $K_v = 4$ . Use a lag compensator,  $G_c(s) = \frac{s + 0.30006}{s + 0.1}$ .

c.

**Program:**

```

K=17.5
G=zpk([], [0, -3, -5], K)
Gc=zpk([-0.3429], [-0.1], 1)
Ge=G*Gc;
T1=feedback(G, 1);
T2=feedback(Ge, 1);
T3=tf(1, [1, 0]);           %Form 1/s to integrate step input
T4=T1*T3;
T5=T2*T3;
t=0:0.1:20;
step(T3, T4, T5, t)       %Show input ramp and ramp responses

```

**Computer response:**

K =

27.9948

```

Zero/pole/gain:
 27.9948

```

```

-----
s (s+3) (s+7)

```

```

Zero/pole/gain:
(s+0.3001)

```

```

-----
(s+0.1)

```

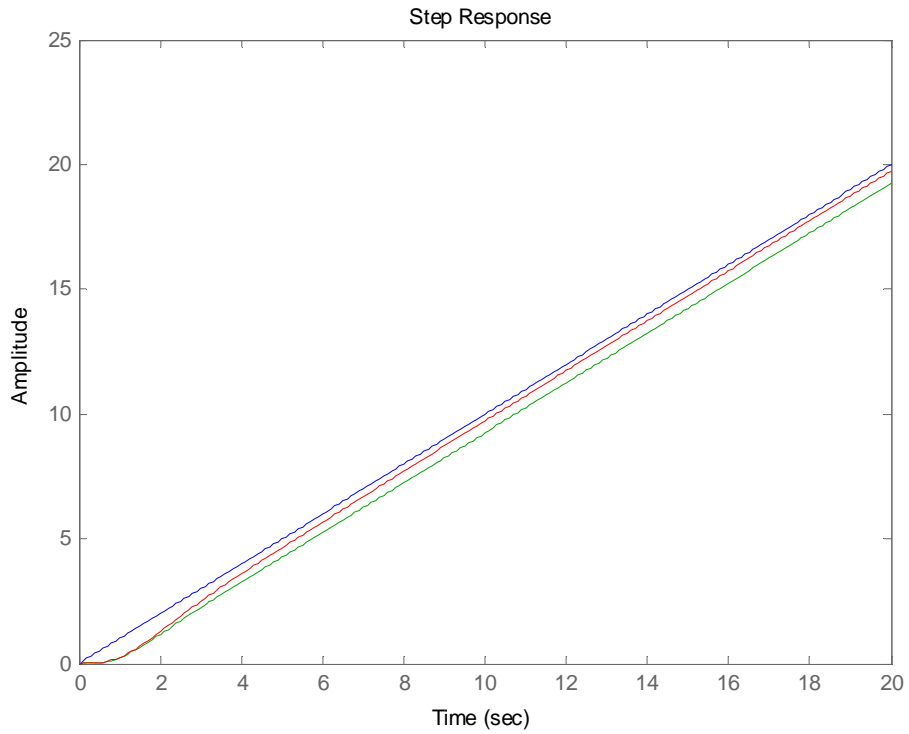

5.

a. Uncompensated: Searching along the  $126.16^\circ$  line (10% overshoot,  $\zeta = 0.59$ ), find the operating point at  $-2.6255 + j3.5929$  with  $K = 88.069$ . Hence,  $K_p = \frac{88.069}{3 * 5 * 7} = 0.8388$ . An improvement of

$\frac{20}{0.8388} = 23.8449$  is required. Let  $G_c(s) = \frac{s + 0.238449}{s + 0.01}$ . Compensated: Searching along the

$126.16^\circ$  line (10% overshoot,  $\zeta = 0.59$ ), find the operating point at  $-2.5859 + j3.5388$  with

$K = 88.7909$ . Hence,  $K_p = \frac{88.7909 * 0.238449}{3 * 5 * 7 * 0.01} = 20.1639$ .

b.

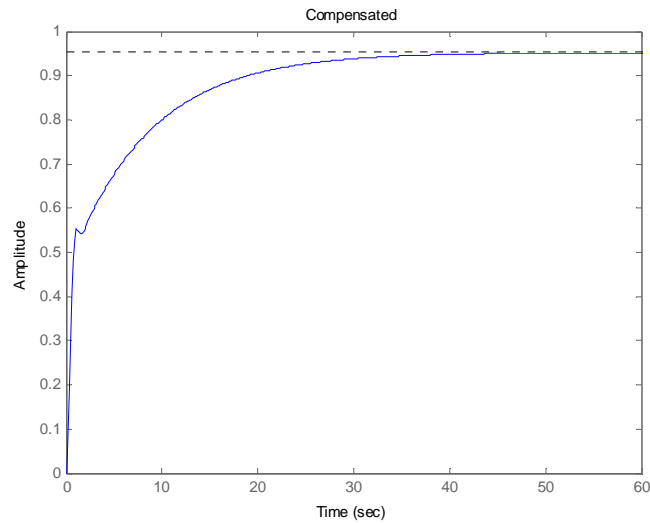
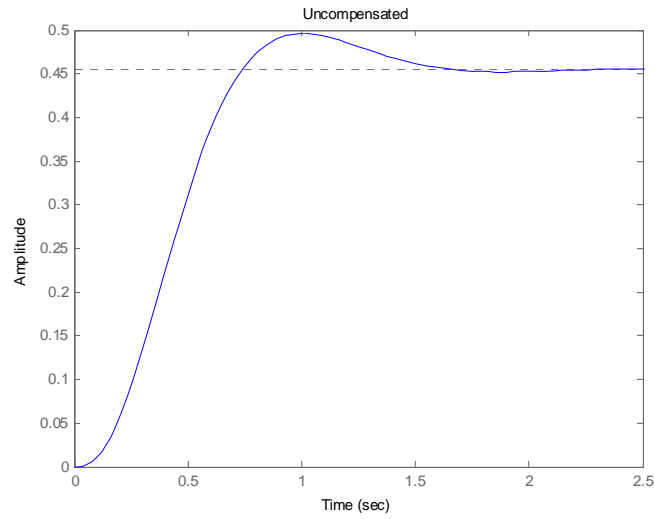

c. From (b), about 28 seconds

6.

Uncompensated: Searching along the 135° line ( $\zeta = 0.707$ ), find the operating point at

$$-2.32 + j2.32 \text{ with } K = 4.6045. \text{ Hence, } K_p = \frac{4.6045}{30} = 0.153; T_s = \frac{4}{2.32} = 1.724 \text{ seconds; } T_p =$$

$$\frac{\pi}{2.32} = 1.354 \text{ seconds; } \%OS = e^{-\zeta\pi/\sqrt{1-\zeta^2}} \times 100 = 4.33\%;$$

$$\omega_n = \sqrt{2.32^2 + 2.32^2} = 3.28 \text{ rad/s; higher-order pole at } -5.366.$$

Compensated: To reduce the settling time by a factor of 2, the closed-loop poles should be  $-4.64 \pm j4.64$ . The summation of angles to this point is  $119^\circ$ . Hence, the contribution of the compensating zero should be  $180^\circ - 119^\circ = 61^\circ$ . Using the geometry shown below,

$$\frac{4.64}{z_c - 4.64} = \tan(61^\circ). \text{ Or, } z_c = 7.21.$$

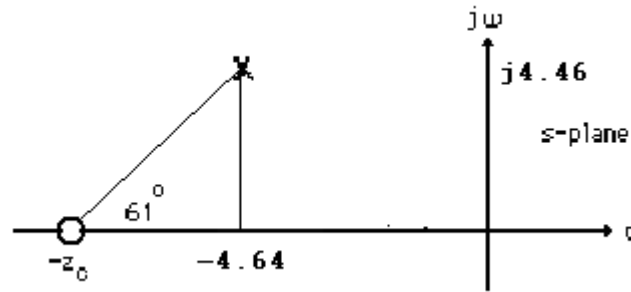

After adding the compensator zero, the gain at  $-4.64 + j4.64$  is  $K = 4.77$ . Hence,

$$K_p = \frac{4.77 \times 6 \times 7.21}{2 \times 3 \times 5} = 6.88. \quad T_s = \frac{4}{4.64} = 0.86 \text{ second}; \quad T_p = \frac{\pi}{4.64} = 0.677 \text{ second};$$

$\%OS = e^{-\zeta\pi/\sqrt{1-\zeta^2}} \times 100 = 4.33\%$ ;  $\omega_n = \sqrt{4.64^2 + 4.64^2} = 6.56 \text{ rad/s}$ ; higher-order pole at  $-5.49$ . The problem with the design is that there is steady-state error, and no effective pole/zero cancellation. The design should be simulated to be sure the transient requirements are met.

7.

**Program:**

```

clf
'Uncompensated System'
numg=[1 6];
deng=poly([-2 -3 -5]);
'G(s)'
G=tf(numg,deng);
Gzpk=zpk(G)
rlocus(G,0:1:100)
z=0.707;
pos=exp(-pi*z/sqrt(1-z^2))*100;
sgrid(z,0)
title(['Uncompensated Root Locus with ', num2str(z), ' Damping Ratio
Line'])
[K,p]=rlocfind(G); %Allows input by selecting point on graphic
'Closed-loop poles = '
p
i=input('Give pole number that is operating point ');
'Summary of estimated specifications'
operatingpoint=p(i)
gain=K
estimated_settling_time=4/abs(real(p(i)))
estimated_peak_time=pi/abs(imag(p(i)))
estimated_percent_overshoot=pos

```

```

estimated_damping_ratio=z
estimated_natural_frequency=sqrt(real(p(i))^2+imag(p(i))^2)
Kp=dcgain(K*G)
'T(s)'
T=feedback(K*G,1)
'Press any key to continue and obtain the step response'
pause
step(T)
title(['Step Response for Uncompensated System with ', num2str(z),...
' Damping Ratio'])
'Press any key to go to PD compensation'
pause
'Compensated system'
done=1;
while done>0
a=input('Enter a Test PD Compensator, (s+a). a = ');
numc=[1 a];
'Gc(s)'
GGc=tf(conv(numg,numc),deng);
GGczpk=zpk(GGc)
wn=4/[(estimated_settling_time/2)*z];
rlocus(GGc)
sgrid(z,wn)
title(['PD Compensated Root Locus with ', num2str(z),...
' Damping Ratio Line', 'PD Zero at ', num2str(a), ', and Required Wn'])
done=input('Are you done? (y=0,n=1) ');
end
[K,p]=rlocfind(GGc); %Allows input by selecting point on graphic
'Closed-loop poles = '
p
i=input('Give pole number that is operating point ');
'Summary of estimated specifications'
operatingpoint=p(i)
gain=K
estimated_settling_time=4/abs(real(p(i)))
estimated_peak_time=pi/abs(imag(p(i)))
estimated_percent_overshoot=pos
estimated_damping_ratio=z
estimated_natural_frequency=sqrt(real(p(i))^2+imag(p(i))^2)
Kp=dcgain(K*GGc)
'T(s)'
T=feedback(K*GGc,1)
'Press any key to continue and obtain the step response'
pause
step(T)
title(['Step Response for Compensated System with ', num2str(z),...
' Damping Ratio'])

```

**Computer response:**

ans =

Uncompensated System

ans =

G(s)

Zero/pole/gain:

(s+6)

-----  
(s+5) (s+3) (s+2)

## 9-12 Chapter 9: Design via Root Locus

```
Select a point in the graphics window
selected_point =
    -2.3104 + 2.2826i

ans =

Closed-loop poles =

p =
    -5.3603
    -2.3199 + 2.2835i
    -2.3199 - 2.2835i

Give pole number that is operating point    2

ans =

Summary of estimated specifications

operatingpoint =
    -2.3199 + 2.2835i

gain =
    4.4662

estimated_settling_time =
    1.7242

estimated_peak_time =
    1.3758

estimated_percent_overshoot =
    4.3255

estimated_damping_ratio =
    0.7070

estimated_natural_frequency =
    3.2552

Kp =
```



0.8932

ans =

T(s)

Transfer function:

$$\frac{4.466 s + 26.8}{s^3 + 10 s^2 + 35.47 s + 56.8}$$

ans =

Press any key to continue and obtain the step response

ans =

Press any key to go to PD compensation

ans =

Compensated system

Enter a Test PD Compensator, (s+a). a = 6

a =

6

ans =

Gc(s)

Zero/pole/gain:

$$\frac{(s+6)^2}{(s+5)(s+3)(s+2)}$$

Are you done? (y=0,n=1) 1

Enter a Test PD Compensator, (s+a). a = 7.1

a =

7.1000

ans =

Gc(s)

Zero/pole/gain:

$$\frac{(s+7.1)(s+6)}{(s+5)(s+3)(s+2)}$$

## 9-14 Chapter 9: Design via Root Locus

```
Are you done? (y=0,n=1) 0
Select a point in the graphics window

selected_point =

    -4.6607 + 4.5423i

ans =

Closed-loop poles =

p =

    -4.6381 + 4.5755i
    -4.6381 - 4.5755i
    -5.4735

Give pole number that is operating point 1

ans =

Summary of estimated specifications

operatingpoint =

    -4.6381 + 4.5755i

gain =

    4.7496

estimated_settling_time =

    0.8624

estimated_peak_time =

    0.6866

estimated_percent_overshoot =

    4.3255

estimated_damping_ratio =

    0.7070

estimated_natural_frequency =

    6.5151

Kp =
```

6.7444

ans =

T(s)

Transfer function:

$$4.75 s^2 + 62.22 s + 202.3$$

---



$$s^3 + 14.75 s^2 + 93.22 s + 232.3$$

ans =

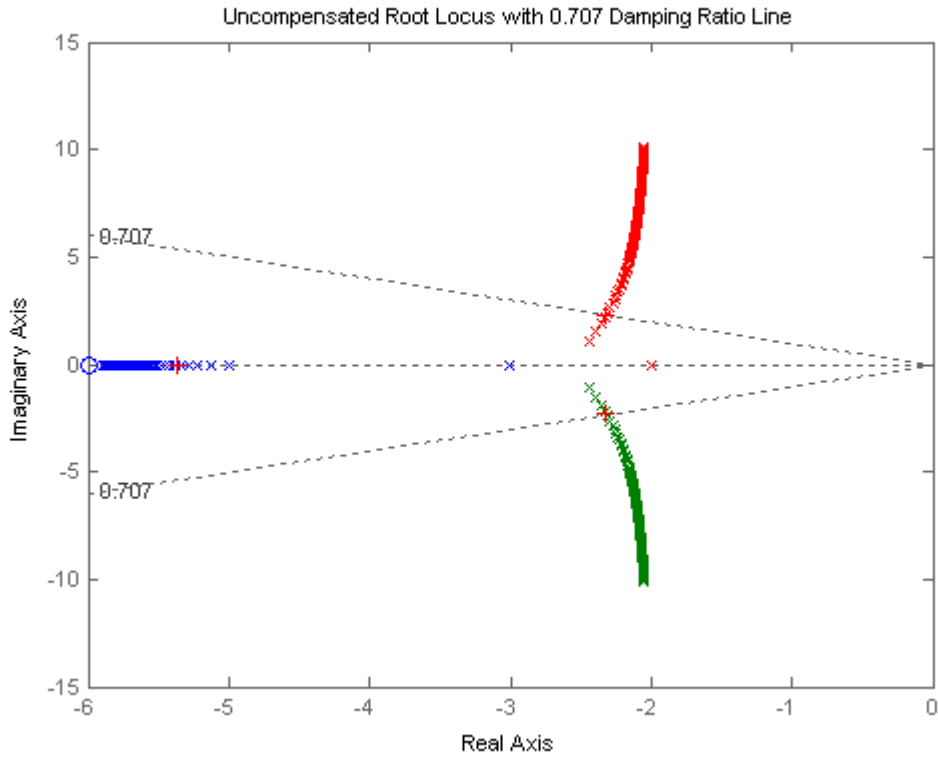
Press any key to continue and obtain the step response

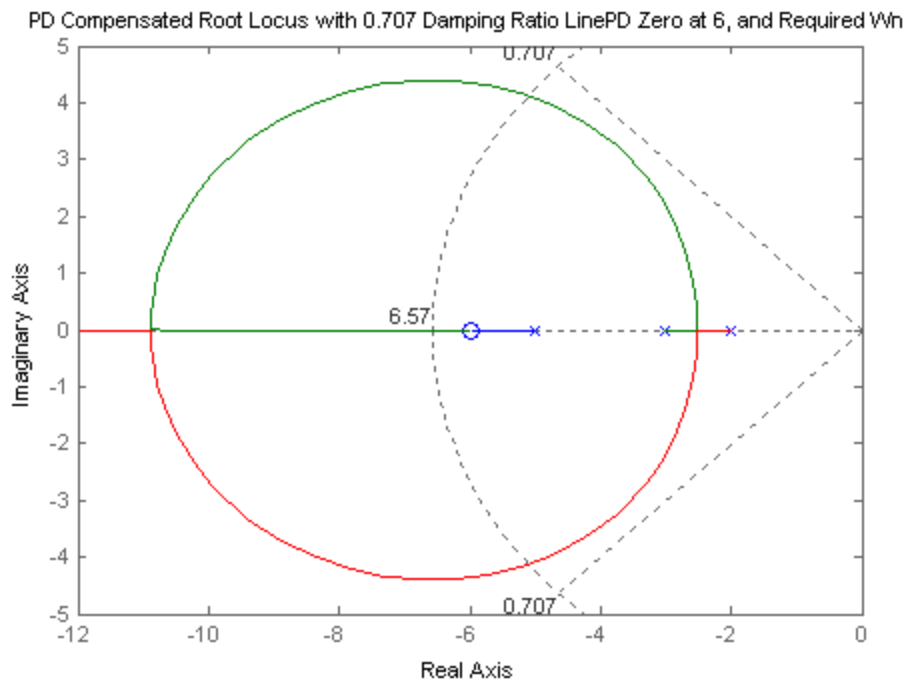
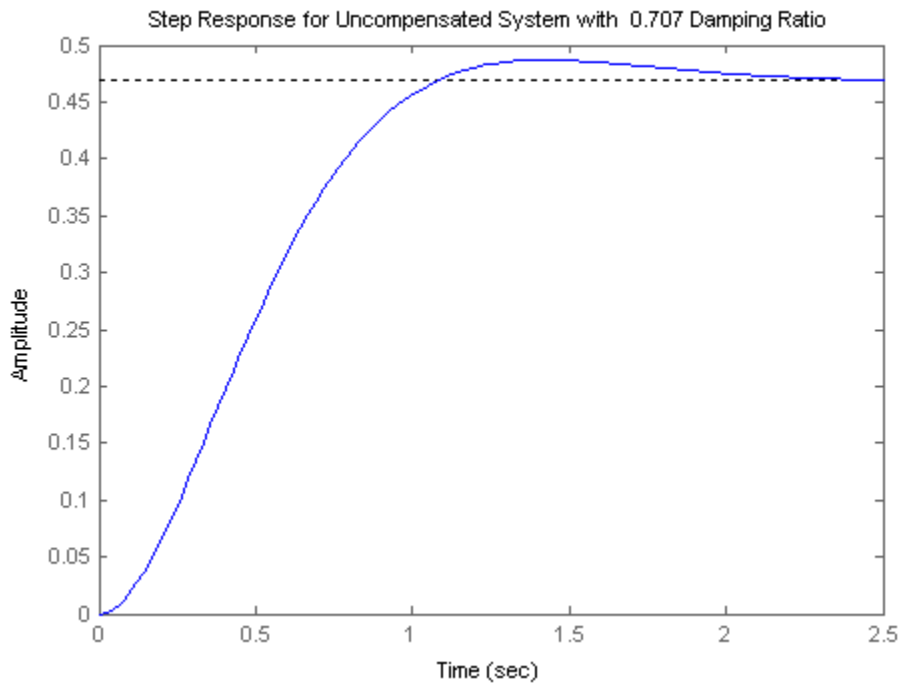

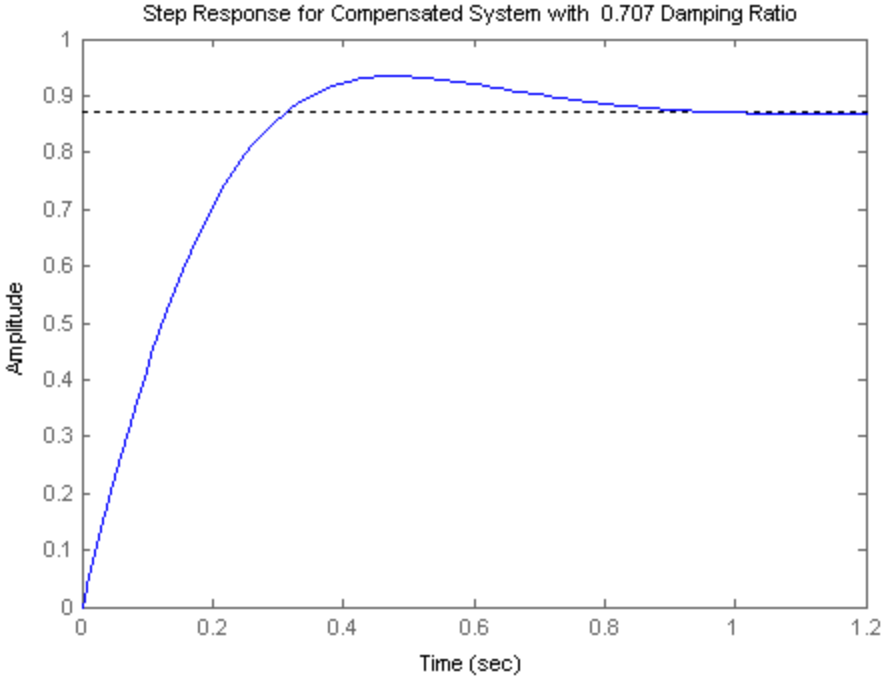
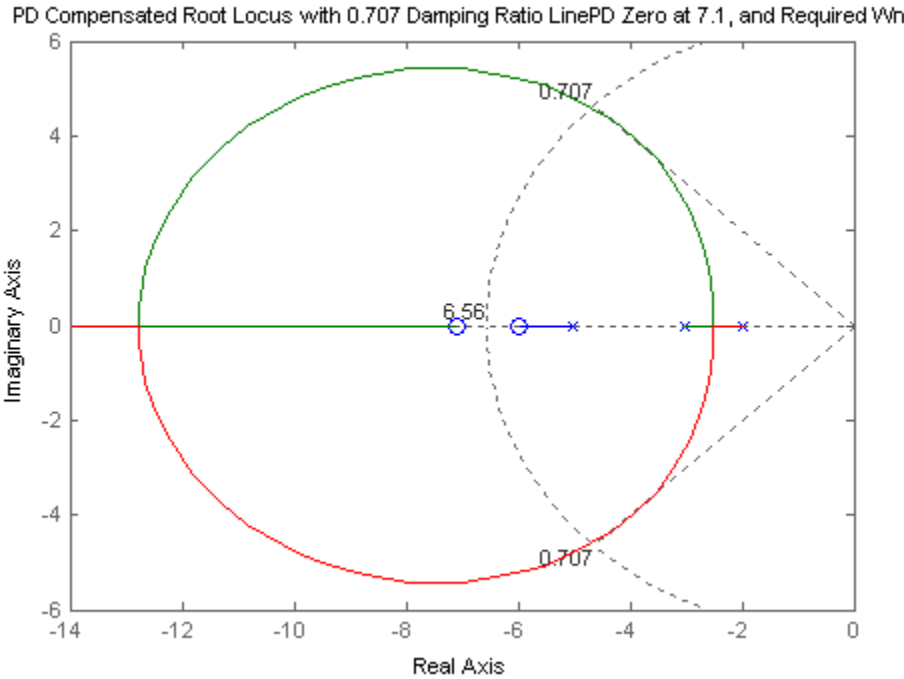



8. The uncompensated system performance is summarized in Table P9.8 below. To improve settling time by 4, the dominant poles need to be at  $-12.7808 \pm j24.9444$ . Summing the angles from the open-loop poles to the design point yields  $72.6507^\circ$ . Thus, the zero must contribute  $180^\circ - 72.6507^\circ = 107.3493^\circ$ . Using the geometry below,

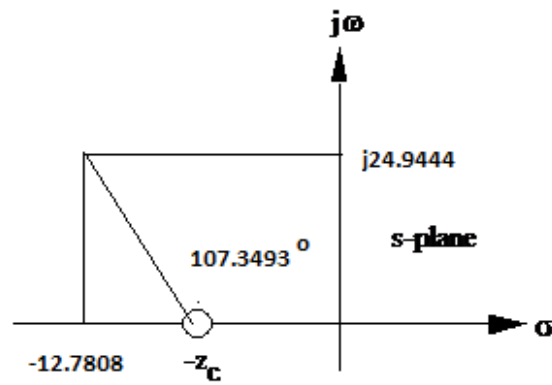

$\frac{24.9444}{12.7808 - z_c} = \tan(180 - 107.3493)$ . Thus,  $z_c = 4.9879$ . Adding the zero and evaluating the gain at the design point yields  $K = 256.819$ . Summarizing results:

Table P9.8

	Uncompensated	Compensated
Plant and compensator	$\frac{K}{s(s+10)(s+20)}$	$\frac{K(s+4.9879)}{s(s+10)(s+20)}$
Feedback	1	1
Dominant poles	$-3.1952 \pm j6.2361$	$-12.7808 \pm j24.9444$
K	1159.2797	699.0243
$\zeta$	0.456	0.456
$\omega_n$	7.0070	<b>28.0281</b>
%OS	20	20
$T_s$	1.2519	<b>0.3130</b>
$T_P$	0.5038	<b>0.1259</b>
$K_v$	5.796	<b>17.433</b>
$e(\infty)$ (ramp)	0.1725	<b>0.05736</b>
Other poles	-23.6084	<b>-4.4384</b>
Zero	None	<b>-4.9879</b>
Comments	Second-order approx. OK	<b>Simulate to be sure of pole/zero cancellation</b>

9.

a.  $\zeta\omega_n = \frac{4}{T_s} = 2.5$ ;  $\zeta = \frac{-\ln\left(\frac{\%OS}{100}\right)}{\sqrt{\pi^2 + \ln^2\left(\frac{\%OS}{100}\right)}} = 0.404$ . Thus,  $\omega_n = 6.188$  rad/s and the operating point

is  $-2.5 \pm j5.67$ .

b. Summation of angles including the compensating zero is  $-120.7274^\circ$ . Therefore, the compensator pole must contribute  $120.7274^\circ - 180^\circ = -59.2726^\circ$ .

c. Using the geometry shown below,  $\frac{5.67}{P_c - 2.5} = \tan 59.2726^\circ$ . Thus,  $P_c = 5.87$ .

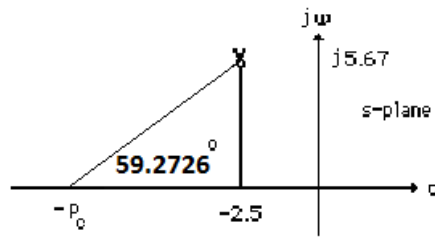

d. Adding the compensator pole and using  $-2.5 + j5.67$  as the test point,  $K = 225.7929$ .

e. Searching the real axis segments for  $K = 225.7929$ , we find higher-order poles at  $-11.5886$ , and  $-1.3624$ .

f. Pole at  $-11.5886$  is 4.64 times further from the imaginary axis than the dominant poles. Pole at  $-1.3624$  may not cancel the zero at  $-1$ . Questionable second-order approximation. System should be simulated.

g.

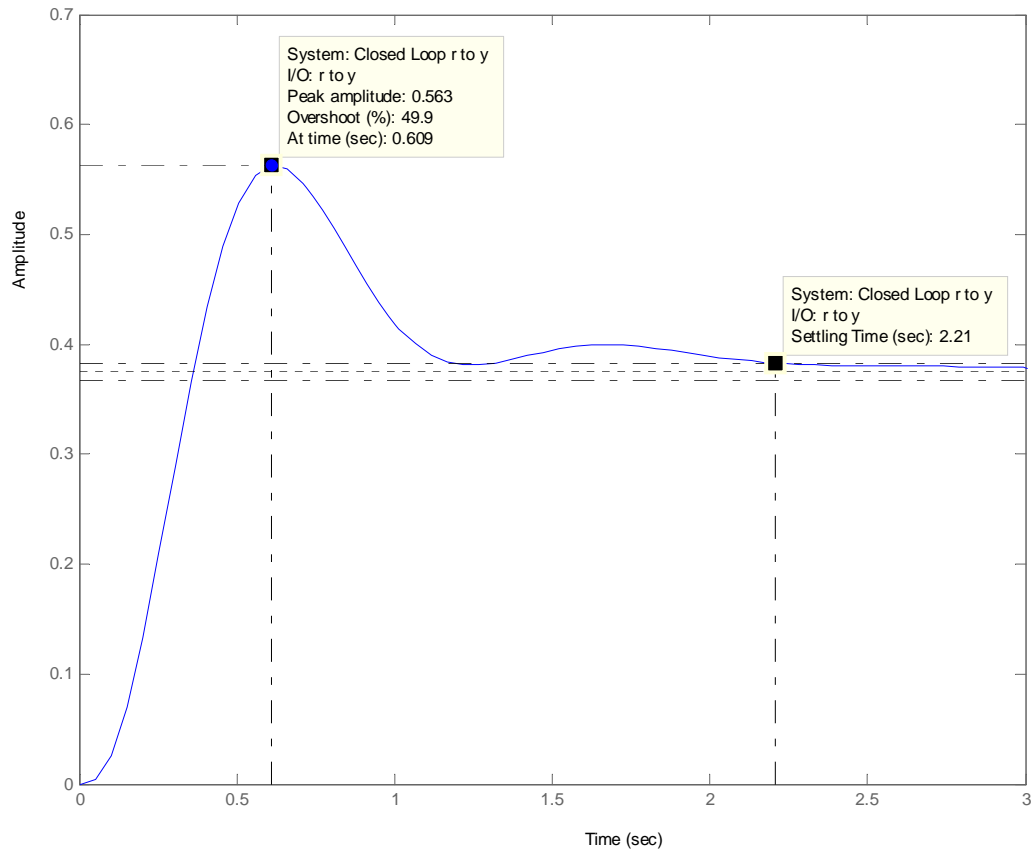



A simulation of the system shows a percent overshoot of 49.9% and a settling time of 2.21 seconds. Thus, the specifications were not met because pole-zero cancellation was not achieved. A redesign is required.

10.

a.  $\zeta\omega_n = \frac{4}{T_s} = 2.4$ ;  $\zeta = \frac{-\ln\left(\frac{\%OS}{100}\right)}{\sqrt{\pi^2 + \ln^2\left(\frac{\%OS}{100}\right)}} = 0.5$ . Thus,  $\omega_n = 4.799$  rad/s and the operating point is

$$-2.4 \pm j4.16.$$

b. Summation of angles including the compensating zero is  $-131.36^\circ$ . Therefore, the compensator pole must contribute  $180^\circ - 131.36^\circ = -48.64^\circ$ . Using the geometry shown below,  $\frac{4.16}{p_c - 2.4} =$

$\tan 48.64^\circ$ . Thus,  $p_c = 6.06$ .

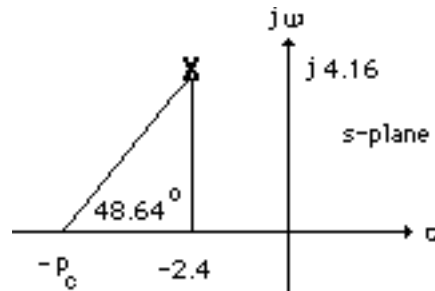

c. Adding the compensator pole and using  $-2.4 + j4.16$  as the test point,  $K = 29.117$ .

d. Searching the real axis segments for  $K = 29.117$ , we find a higher-order pole at  $-1.263$ .

e. Pole at  $-1.263$  is near the zero at  $-1$ . Simulate to ensure accuracy of results.

f.  $K_a = \frac{29.117}{6.06} = 4.8$

g.

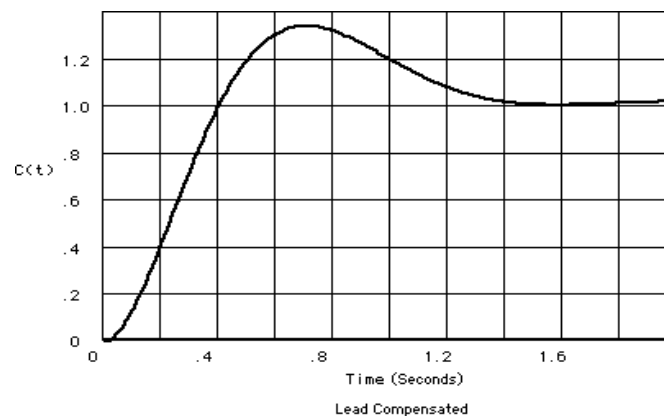

From the plot,  $T_s = 1.4$  seconds;  $T_p = 0.68$  seconds;  $\%OS = 35\%$ .

11.  
a.

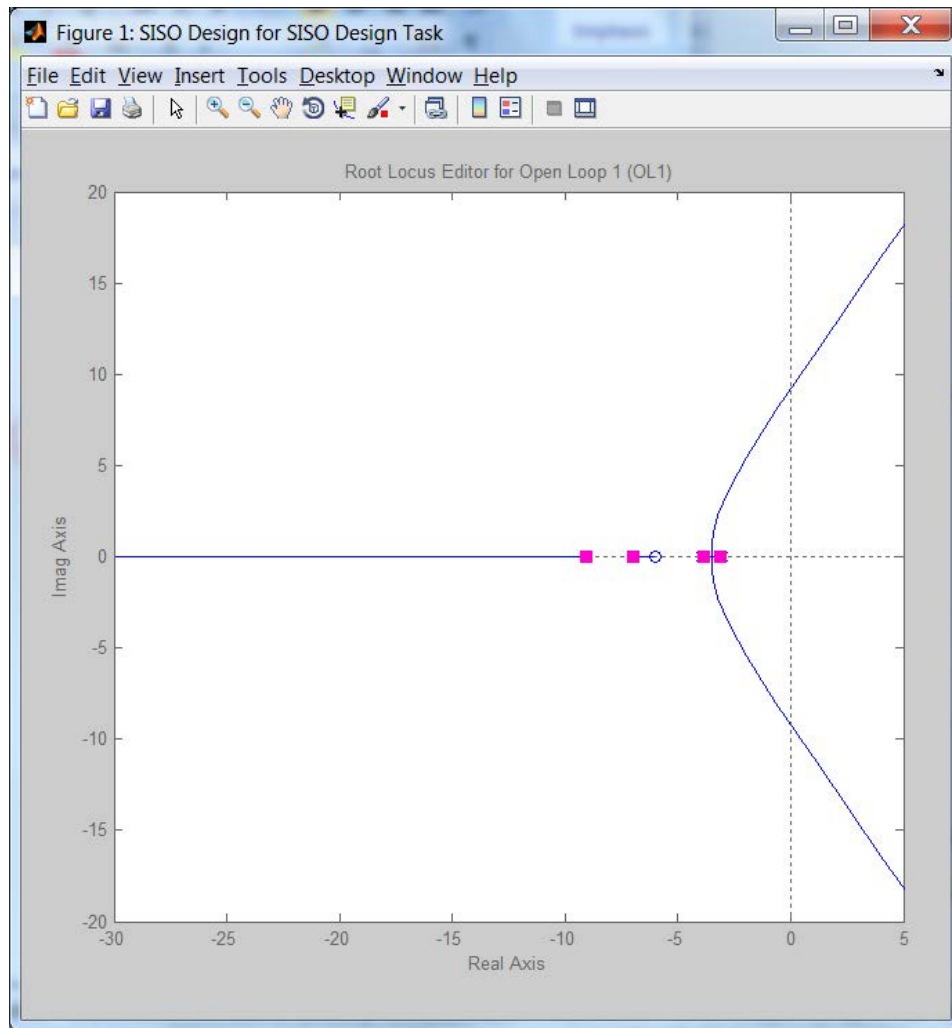

**b. and c.** Searching along the  $\zeta = 0.8$  line ( $143.13^\circ$ ), find the operating point at  $-3.2 + j2.38$  with  $K = 45.9$ .

**d.** Since  $\zeta\omega_n = \frac{4}{T_s}$ , the real part of the compensated dominant pole is  $-4$ . The imaginary part is  $4 \tan (180^\circ - 143.13^\circ) = 3$ . Using the uncompensated system's poles and zeros along with the compensator zero at  $-4.5$ , the summation of angles to the design point,  $-4 + j3$  is  $-137.55^\circ$ . Thus, the contribution of the compensator pole must be  $137.55 - 180^\circ = -42.45^\circ$ . Using the following geometry,

$$\frac{3}{p_c - 4} = \tan 42.45^\circ, \text{ or } p_c = 7.28.$$

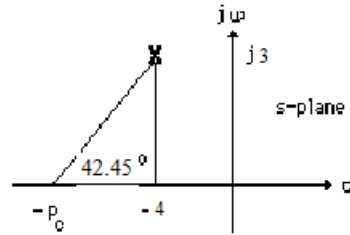

Adding the compensator pole and using  $-4 + j3$  as the test point,  $K = 105.46$ .

e. Compensated: Searching the real axis segments for  $K = 105.46$ , we find higher-order poles at 12.32, and approximately at  $-4.71 \pm 1.38$ . Since there is no pole/zero cancellation with the zeros at -6 and -4.5, the system should be simulated to check the settling time.

f.

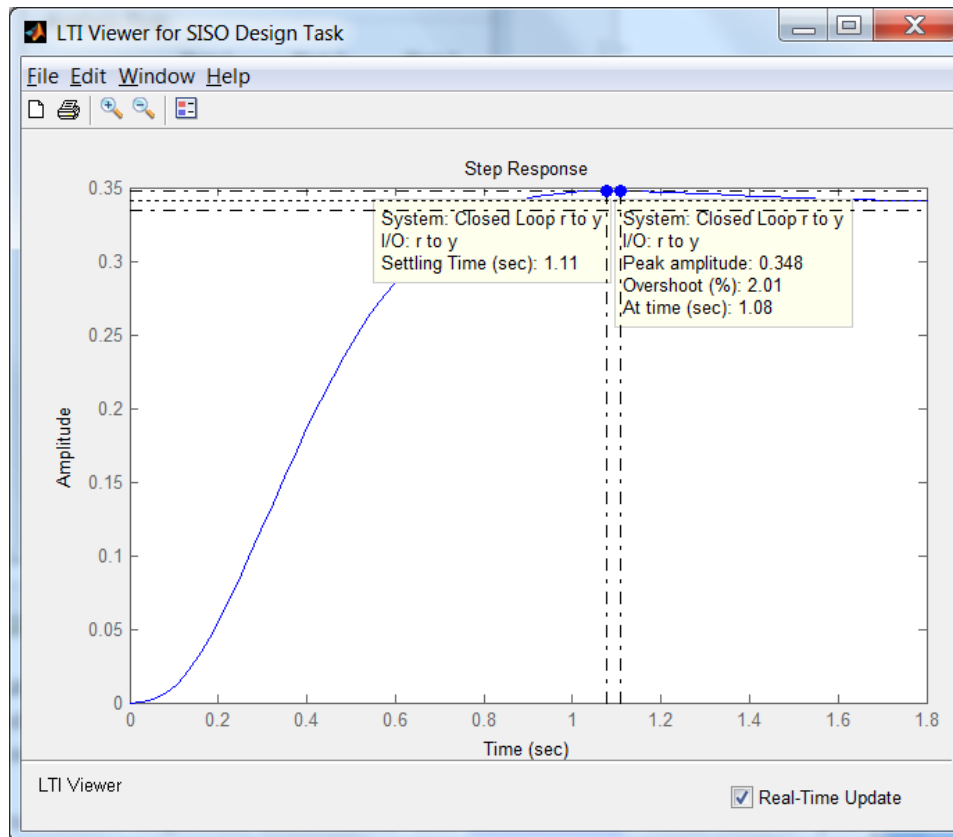

The graph shows about 2% overshoot and a 1.1 second settling time compared to a desired 1.52% overshoot and a settling time of 1 second.

12.

**Program:**

```
clf
numg=[1 6];
deng=poly([-3 -4 -7 -9]);
'G(s)'
G=tf(numg,deng);
```

```

Gzpk=zpk(G)
rlocus(G)
z=0.8;
pos=exp(-pi*z/sqrt(1-z^2))*100;
sgrid(z,0)
title(['Uncompensated Root Locus with ' , num2str(z), ' Damping
Ratio Line'])
[K,p]=rlocfind(G);
'Closed-loop poles = '
p
i=input('Give pole number that is operating point ');
'Summary of estimated specifications'
operatingpoint=p(i)
gain=K
estimated_settling_time=4/abs(real(p(i)))
estimated_peak_time=pi/abs(imag(p(i)))
estimated_percent_overshoot=pos
estimated_damping_ratio=z
estimated_natural_frequency=sqrt(real(p(i))^2+imag(p(i))^2)
Kp=K*numg(max(size(numg)))/deng(max(size(deng)))
'T(s)'
T=feedback(K*G,1)
'Press any key to continue and obtain the step response'
pause
step(T)
title(['Step Response for Uncompensated System with ' ,
num2str(z),...
' Damping Ratio'])
'Press any key to go to Lead compensation'
pause
'Compensated system'
b=4.5;
'Lead Zero at -4.5 '
done=1;
while done>0
a=input('Enter a Test Lead Compensator Pole, (s+a). a = ');
'Gc(s)'
Gc=tf([1 b],[1 a])
GGc=G*Gc;
[numggc,denggc]=tfdata(GGc,'v');
'G(s)Gc(s)'
GGczpk=zpk(GGc)
wn=4/((1)*z);
rlocus(GGc);
sgrid(z,wn)
title(['Lead Compensated Root Locus with ' , num2str(z),...
' Damping Ratio Line, Lead Pole at ' , num2str(-a), ', and Required
Wn'])
done=input('Are you done? (y=0,n=1) ');
end
[K,p]=rlocfind(GGc); %Allows input by selecting point on graphic
'Closed-loop poles = '
p
i=input('Give pole number that is operating point ');
'Summary of estimated specifications'
operatingpoint=p(i)
gain=K

```

```

estimated_settling_time=4/abs(real(p(i)))
estimated_peak_time=pi/abs(imag(p(i)))
estimated_percent_overshoot=pos
estimated_damping_ratio=z
estimated_natural_frequency=sqrt(real(p(i))^2+imag(p(i))^2)
Kp=dcgain(K*GGc)
'T(s)'
T=feedback(K*GGc,1)
'Press any key to continue and obtain the step response'
pause
step(T)
title(['Step Response for Compensated System with ' ,
num2str(z),...
' Damping Ratio'])

```

**Computer response:**

```

ans =

G(s)

Zero/pole/gain:
      (s+6)
-----
(s+9) (s+7) (s+4) (s+3)

Select a point in the graphics window

selected_point =

    -3.1453 + 2.4074i

ans =

Closed-loop poles =

p =

    -10.3301
     -6.3017
    -3.1841 + 2.4187i
    -3.1841 - 2.4187i

Give pole number that is operating point    3

ans =

Summary of estimated specifications

operatingpoint =

    -3.1841 + 2.4187i

gain =

```

47.4666

estimated\_settling\_time =

1.2562

estimated\_peak\_time =

1.2989

estimated\_percent\_overshoot =

1.5165

estimated\_damping\_ratio =

0.8000

estimated\_natural\_frequency =

3.9985

Kp =

0.3767

ans =

T(s)

Transfer function:

$$47.47 s + 284.8$$

-----  
 $s^4 + 23 s^3 + 187 s^2 + 680.5 s + 1041$

ans =

Press any key to continue and obtain the step response

ans =

Press any key to go to Lead compensation

ans =

Compensated system

ans =

Lead Zero at -4.5

Enter a Test Lead Compensator Pole, (s+a). a = 12

ans =

Gc(s)

Transfer function:

$$\frac{s + 4.5}{s + 12}$$

ans =

G(s)Gc(s)

Zero/pole/gain:

$$\frac{(s+6) (s+4.5)}{(s+12) (s+9) (s+7) (s+4) (s+3)}$$

Are you done? (y=0,n=1) 1

Enter a Test Lead Compensator Pole, (s+a). a = 11

ans =

Gc(s)

Transfer function:

$$\frac{s + 4.5}{s + 11}$$

ans =

G(s)Gc(s)

Zero/pole/gain:

$$\frac{(s+6) (s+4.5)}{(s+11) (s+9) (s+7) (s+4) (s+3)}$$

Are you done? (y=0,n=1) 1

Enter a Test Lead Compensator Pole, (s+a). a = 20

ans =

Gc(s)

Transfer function:

$$\frac{s + 4.5}{s + 20}$$

ans =

G(s)Gc(s)

Zero/pole/gain:

(s+6) (s+4.5)

-----  
 (s+20) (s+9) (s+7) (s+4) (s+3)

Are you done? (y=0,n=1) 1

Enter a Test Lead Compensator Pole, (s+a). a = 5

ans =

Gc(s)

Transfer function:

s + 4.5

-----  
 s + 5

ans =

G(s)Gc(s)

Zero/pole/gain:

(s+6) (s+4.5)

-----  
 (s+9) (s+7) (s+5) (s+4) (s+3)

Are you done? (y=0,n=1) 1

Enter a Test Lead Compensator Pole, (s+a). a = 7

ans =

Gc(s)

Transfer function:

s + 4.5

-----  
 s + 7

ans =

G(s)Gc(s)

Zero/pole/gain:

(s+6) (s+4.5)

-----  
 (s+9) (s+7)^2 (s+4) (s+3)

Are you done? (y=0,n=1) 1

Enter a Test Lead Compensator Pole, (s+a). a = 7.2

ans =

Gc(s)



Transfer function:

$$\frac{s + 4.5}{s + 7.2}$$

ans =

G(s)Gc(s)

Zero/pole/gain:

$$\frac{(s+6) (s+4.5)}{(s+9) (s+7.2) (s+7) (s+4) (s+3)}$$

Are you done? (y=0,n=1) 1

Enter a Test Lead Compensator Pole, (s+a). a = 7.3

ans =

Gc(s)

Transfer function:

$$\frac{s + 4.5}{s + 7.3}$$

ans =

G(s)Gc(s)

Zero/pole/gain:

$$\frac{(s+6) (s+4.5)}{(s+9) (s+7.3) (s+7) (s+4) (s+3)}$$

Are you done? (y=0,n=1) 0

Select a point in the graphics window

selected\_point =

$$-3.9990 + 2.9365i$$

ans =

Closed-loop poles =

p =

$$\begin{aligned} & -11.7210 \\ & -4.0254 + 2.9457i \\ & -4.0254 - 2.9457i \\ & -5.7292 \\ & -4.7990 \end{aligned}$$

Give pole number that is operating point 2

```

ans =
Summary of estimated specifications

operatingpoint =
    -4.0254 + 2.9457i

gain =
    92.5690

estimated_settling_time =
    0.9937

estimated_peak_time =
    1.0665

estimated_percent_overshoot =
    1.5165

estimated_damping_ratio =
    0.8000

estimated_natural_frequency =
    4.9881

Kp =
    0.4529

ans =
T(s)

Transfer function:
          92.57 s^2 + 972 s + 2499
-----
s^5 + 30.3 s^4 + 354.9 s^3 + 2091 s^2 + 6349 s + 8018

ans =
Press any key to continue and obtain the step response
>>

```

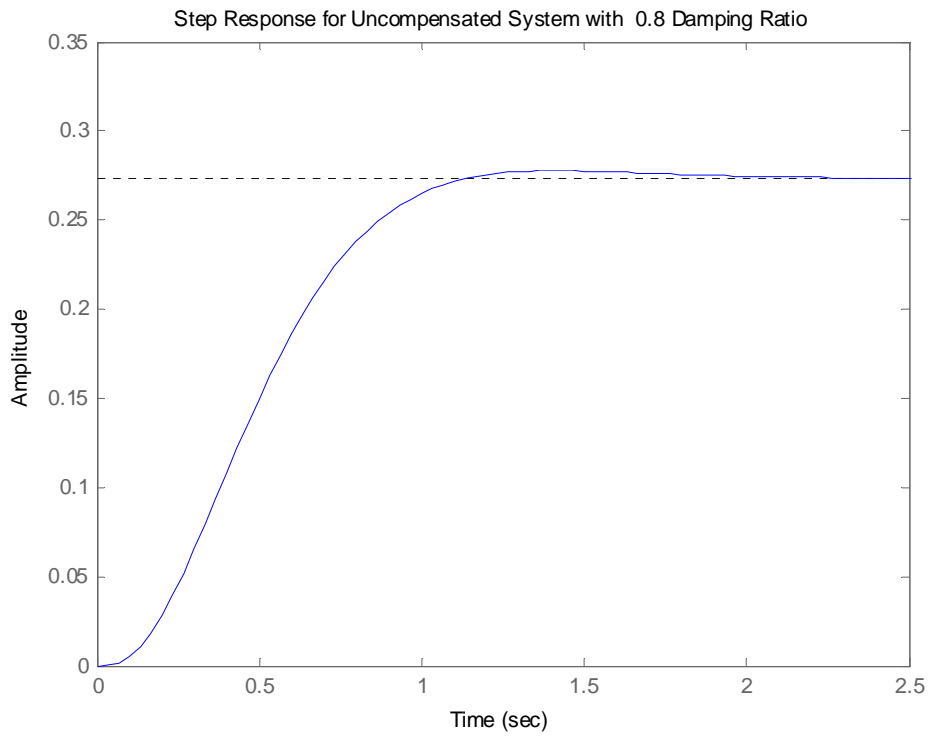
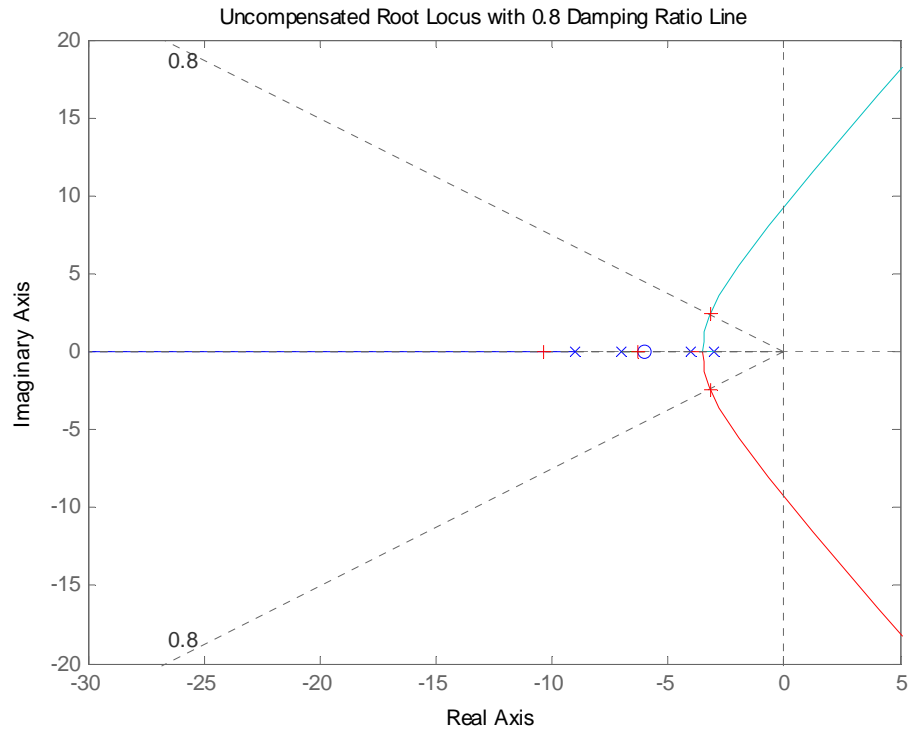

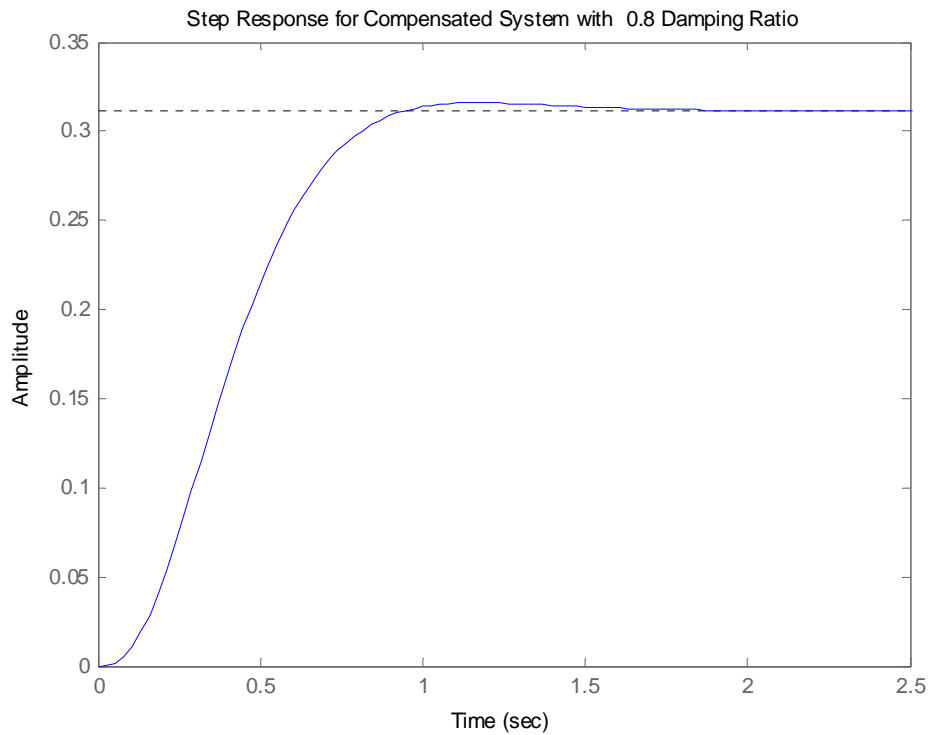
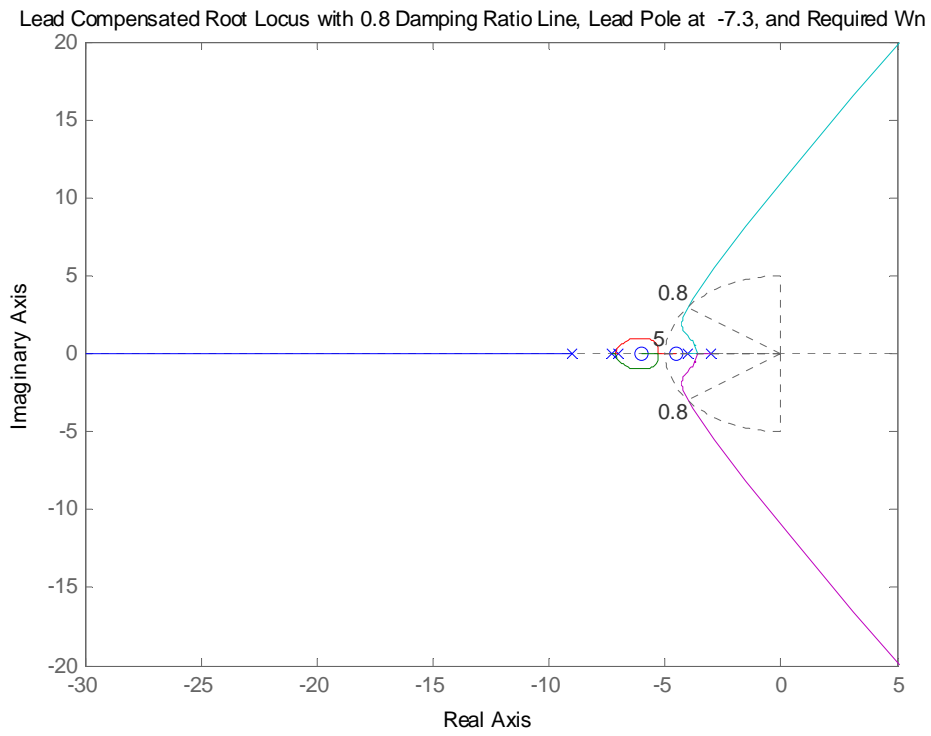

13.

a. Searching along the 117.13° line (%OS = 20%;  $\zeta = 0.456$ ), find the operating point at  $-6.39 + j12.47$  with  $K = 9273$ . Searching along the real axis for  $K = 9273$ , we find a higher-order pole

at  $-47.22$ . Thus,  $T_s = \frac{4}{\zeta\omega_n} = \frac{4}{6.39} = 0.626$  second.

b. For the settling time to decrease by a factor of 2,  $\text{Re} = -\zeta\omega_n = -6.39 \times 2 = -12.78$ . The imaginary part is  $\text{Im} = -12.78 \tan 117.13^\circ = 24.94$ . Hence, the compensated closed-loop poles are  $-12.78 \pm j24.94$ . A settling time of 0.313 second would result.

c. Assume a compensator zero at  $-20$ . Using the uncompensated system's poles along with the compensator zero, the summation of angles to the design point,  $-12.78 \pm j24.94$  is  $-159.63^\circ$ . Thus, the contribution of the compensator pole must be  $159.63^\circ - 180^\circ = -20.37^\circ$ . Using the following geometry,

$\frac{24.94}{p_c - 12.78} = \tan 20.37^\circ$ , or  $p_c = 79.95$ .

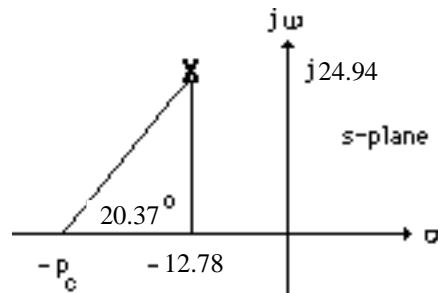

Adding the compensator pole and using  $-12.78 \pm j24.94$  as the test point,  $K = 74130$ .

d.

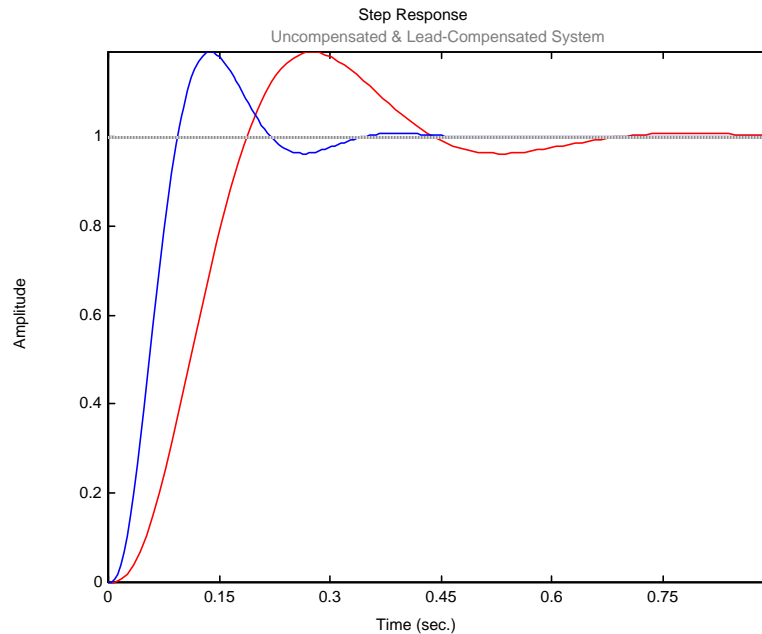

14.

a. Searching along the  $110.97^\circ$  line ( $\%OS = 30\%$ ;  $\zeta = 0.358$ ), find the operating point at  $-2.065 + j5.388$  with  $K = 366.8$ . Searching along the real axis for  $K = 366.8$ , we find a higher-order pole at  $-16.87$ . Thus,  $T_s = \frac{4}{\zeta\omega_n} = \frac{4}{2.065} = 1.937$  seconds. For the settling time to decrease by a

factor of 2,  $\text{Re} = -\zeta\omega_n = -2.065 \times 2 = -4.13$ . The imaginary part is  $-4.13 \tan 110.97^\circ = 10.77$ . Hence, the compensated dominant poles are  $-4.13 \pm j10.77$ . The compensator zero is at  $-7$ . Using the uncompensated system's poles along with the compensator zero, the summation of angles to the design point,  $-4.13 \pm j10.77$  is  $-162.06^\circ$ . Thus, the contribution of the compensator pole must be  $-162.06^\circ - 180^\circ = -17.94^\circ$ . Using the following geometry,  $\frac{10.77}{p_c - 4.13} = \tan 17.94^\circ$ , or  $p_c = 37.4$ .

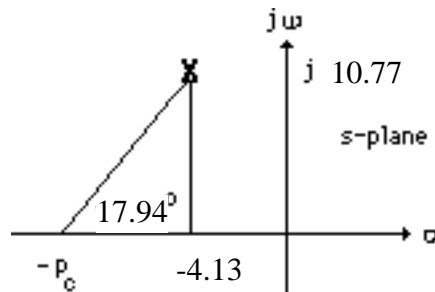

Adding the compensator pole and using  $-4.13 \pm j10.77$  as the test point,  $K = 5443$ .

**b.** Searching the real axis segments for  $K = 5443$  yields higher-order poles at approximately  $-8.12$  and  $-42.02$ . The pole at  $-42.02$  can be neglected since it is more than five times further from the imaginary axis than the dominant pair. The pole at  $-8.12$  may not be canceling the zero at  $-7$ . Hence, simulate to be sure the requirements are met.

**c.**

**Program:**

```
'Uncompensated System G1(s)'  
numg1=1;  
deng1=poly([-15 (-3+2*j) (-3-2*j)]);  
G1=tf(numg1,deng1)  
G1zpk=zpk(G1)  
K1=366.8  
'T1(s)'  
T1=feedback(K1*G1,1);  
T1zpk=zpk(T1)  
'Compensator Gc(s)'  
numc=[1 7];  
denc=[1 37.4];  
Gc=tf(numc,denc)  
'Compensated System G2(s) = G1(s)Gc(s)'  
K2=5443  
G2=G1*Gc;  
G2zpk=zpk(G2)  
'T2(s)'  
T2=feedback(K2*G2,1);  
T2zpk=zpk(T2)  
step(T1,T2)  
title(['Uncompensated and Lead Compensated Systems'])
```

**Computer response:**

ans =

Uncompensated System G1(s)

Transfer function:

$$\frac{1}{s^3 + 21s^2 + 103s + 195}$$

Zero/pole/gain:

$$\frac{1}{(s+15)(s^2 + 6s + 13)}$$

K1 =

366.8000

ans =

T1(s)

Zero/pole/gain:

$$\frac{366.8}{(s+16.87)(s^2 + 4.132s + 33.31)}$$

ans =

Compensator  $G_c(s)$

Transfer function:

$$\frac{s + 7}{s + 37.4}$$

ans =

Compensated System  $G_2(s) = G_1(s)G_c(s)$

K2 =

5443

Zero/pole/gain:

$$\frac{(s+7)}{(s+37.4)(s+15)(s^2 + 6s + 13)}$$

ans =

$T_2(s)$

Zero/pole/gain:

$$\frac{5443(s+7)}{(s+42.02)(s+8.118)(s^2 + 8.261s + 133.1)}$$

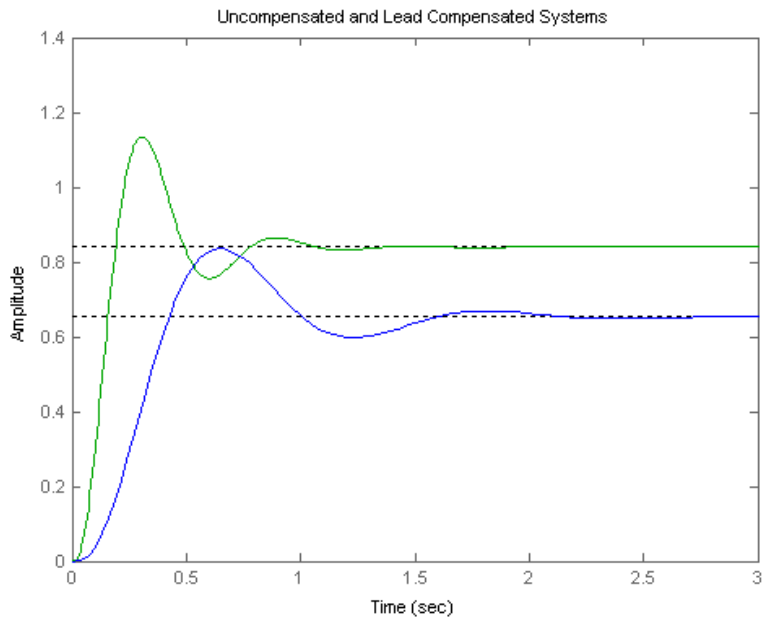



15.

a. Searching the 15% overshoot line ( $121.127^\circ$ ) for  $180^\circ$  yields  $-0.372 + j0.615$ . Hence,  $T_s = \frac{4}{\sigma_d} = \frac{4}{0.372} = 10.75$  seconds.

b. For 7 seconds settling time,  $\sigma_d = \frac{4}{T_s} = \frac{4}{7} = 0.571$ .  $\omega_d = 0.571 \tan(180^\circ - 121.127^\circ) = 0.946$ .

Therefore, the design point is  $-0.571 + j0.946$ . Summing the angles of the uncompensated system's poles as well as the compensator pole at  $-15$  yields  $-213.493^\circ$ . Therefore, the compensator zero must contribute  $(213.493^\circ - 180^\circ) = 33.493^\circ$ . Using the geometry below,

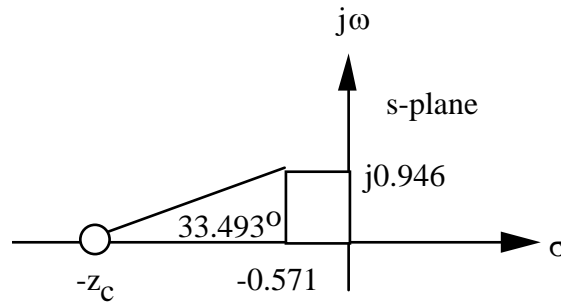

$\frac{0.946}{z_c - 0.571} = \tan(33.493^\circ)$ . Hence,  $z_c = 2$ . The compensated open-loop transfer function is

$\frac{K(s+2)}{s(s+1)(s^2+10s+26)(s+15)}$ . Evaluating the gain for this function at the point,  $-0.571 + j0.946$  yields  $K = 207.512$ .

c.

**Program:**

```
numg= 207.512*[1 2];
r=roots([1,10,26]);
deng=poly([0 , -1, r(1),r(2), -15]);
'G(s)'
G=tf(numg,deng);
Gzpk=zpk(G)
T=feedback(G,1);
step(T)
title(['Step Response for Design of Ts = 7, %OS = 15'])
```

**Computer response:**

ans =

G(s)

Zero/pole/gain:

```
207.512 (s+2)
-----
s (s+15) (s+1) (s^2 + 10s + 26)
```

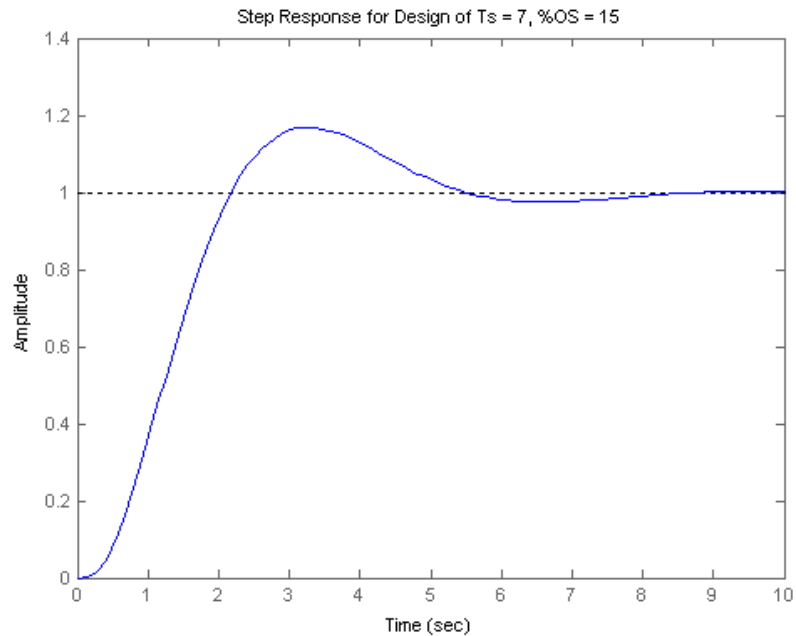

16.

a. From 20.5% overshoot evaluate  $\zeta = 0.45$ . Also, since  $\zeta\omega_n = \frac{4}{T_s} = \frac{4}{3}$ ,  $\omega_n = 2.963$ . The

compensated dominant poles are located at  $-\zeta\omega_n \pm j\omega_n\sqrt{1-\zeta^2} = -1.3333 \pm j2.6432$ . Assuming the compensator zero at  $-0.02$ , the contribution of open-loop poles and the compensator zero to the design point,  $-1.3333 \pm j2.6432$  is  $-175.78^\circ$ . Hence, the compensator pole must contribute

$175.78^\circ - 180^\circ = -4.22^\circ$ . Using the following geometry,  $\frac{2.6432}{p_c - 1.3333} = \tan 4.22^\circ$ , or  $p_c = 37.16$

Adding the pole to the system,  $K = 4401.52$  at the design point..

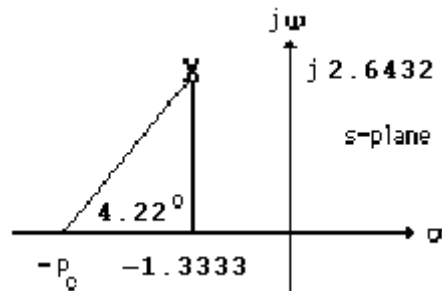

b. Searching along the real axis segments of the root locus for  $K = 4401.52$ , we find higher-order poles at  $-0.0202$ ,  $-13.46$ , and  $-37.02$ . There is pole/zero cancellation at  $-0.02$ . Also, the poles at ,

-13.46, and -37.02 are at least 5 times the design point's real part. Thus, the second-order approximation is valid.

c.

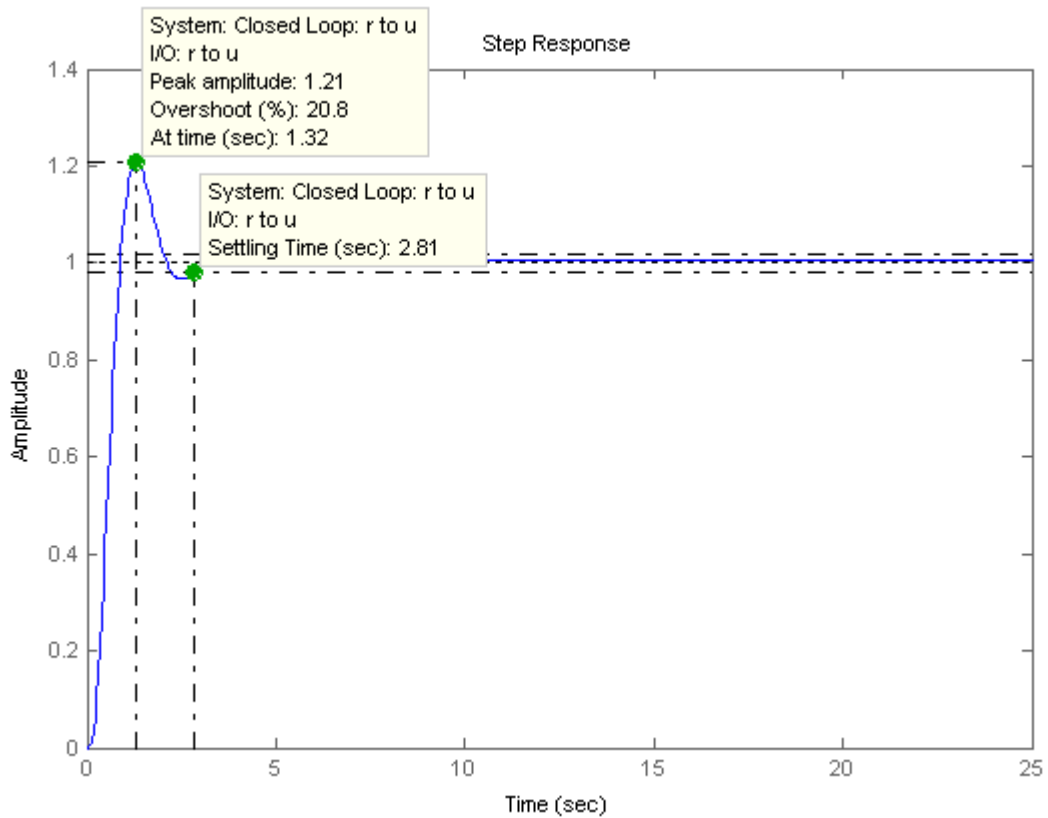

From the plot,  $T_s = 2.81$  seconds, and  $\%OS = 20.8\%$ . Thus, the requirements are met.

17.

a.  $\zeta\omega_n = \frac{4}{T_s} = \frac{4}{0.5} = 8$ . Since  $\zeta = 0.4$ ,  $\omega_n = 20$ . Therefore the compensated closed-loop poles are

located at  $-\zeta\omega_n \pm j\omega_n\sqrt{1-\zeta^2} = -8 \pm j18.33$ .

b. Using the system's poles along with the compensator's pole at -15, the sum of angles to the test point  $-8 \pm j18.33$  is  $-293.4^\circ$ . Therefore, the compensator's zero must contribute  $293.4^\circ - 180^\circ = 113.4^\circ$ . Using the following geometry,  $\frac{18.33}{8 - z_c} = \tan 66.6^\circ$ , or  $z_c = 0.0679$ .

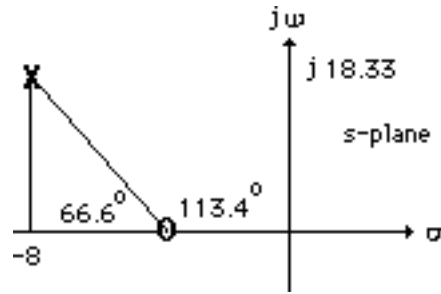

c. Adding the compensator zero and using  $-8 \pm j18.33$  as the test point,  $K = 7297$ .

d. Making a second-order assumption, the predicted performance is as follows:

**Uncompensated:** Searching along the  $133.58^\circ$  line ( $\zeta = 0.4$ ), find the uncompensated closed-loop pole at  $-5.43 + j12.45$  with  $K = 3353$ . Hence,  $T_s = \frac{4}{\zeta\omega_n} = 0.74$  seconds;  $\%OS = e^{-\zeta\pi/\sqrt{1-\zeta^2}} \times 100 =$

$25.38\%$ ;  $K_p = \frac{3353}{101 \times 20} = 1.66$ . Checking the second-order assumption by searching the real axis

segments of the root locus for  $K = 3353$ , we find a higher-order pole at  $-29.13$ . Since this pole is more than five times further from the imaginary axis than the dominant pair, the second order assumption is reasonable.

**Compensated:** Using the compensated dominant pole location,  $-8 \pm j18.33$ ,  $T_s = \frac{4}{\zeta\omega_n} = 0.5$

seconds;  $\%OS = e^{-\zeta\pi/\sqrt{1-\zeta^2}} \times 100 = 25.38\%$ ;  $K_p = \frac{7297 \times 0.0679}{101 \times 20 \times 15} = 0.016$ . Checking the second-

order assumption by searching the real axis segments of the root locus for  $K = 7297$ , we find higher-order poles at  $-2.086$  and  $-36.91$ . The poles are not five times further from the imaginary axis nor do they yield pole/zero cancellation. The second-order assumption is not valid.

e.

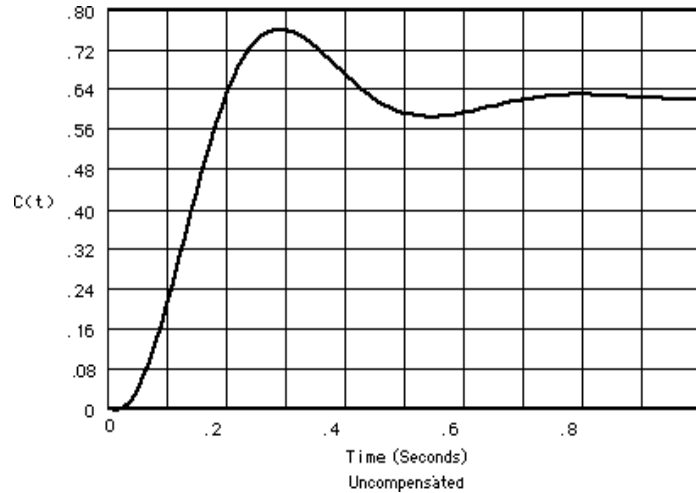

The uncompensated system exhibits a steady-state error of 0.38, a percent overshoot of 22.5%, and a settling time of 0.78 seconds.

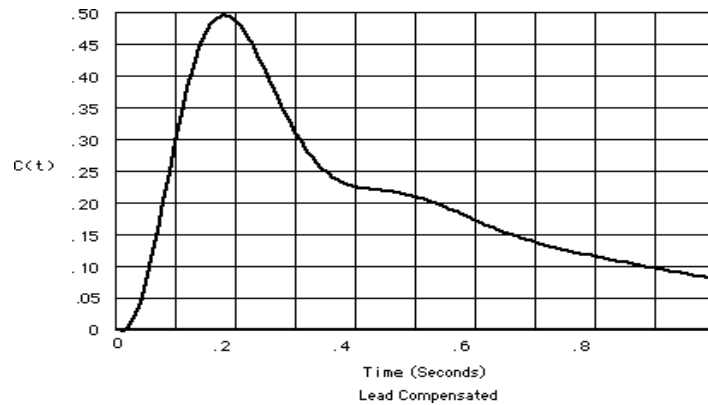

Since there is no pole/zero cancellation the closed-loop zero near the origin produces a large steady-state error. The student should be asked to find a viable design solution to this problem by choosing the compensator zero further from the origin. For example, placing the compensator zero at -20 yields a compensator pole at -90.75 and a gain of 28730. This design yields a valid second-order approximation.

18.

a. Since %OS = 1.5%,  $\zeta = \frac{-\ln\left(\frac{\%OS}{100}\right)}{\sqrt{\pi^2 + \ln^2\left(\frac{\%OS}{100}\right)}} = 0.8$ . Since  $T_s = \frac{4}{\zeta\omega_n} = \frac{2}{3}$  second,

$\omega_n = 7.49$  rad/s. Hence, the location of the closed-loop poles must be  $-6 \pm j4.49$ . The summation of angles from open-loop poles to  $-6 \pm j4.49$  is  $-226.3^\circ$ . Therefore, the design point is not on the root locus.

**b.** A compensator whose angular contribution is  $226.3^\circ - 180^\circ = 46.3^\circ$  is required. Assume a compensator zero at  $-5$  canceling the pole. Thus, the breakaway from the real axis will be at the required  $-6$  if the compensator pole is at  $-9$  as shown below.

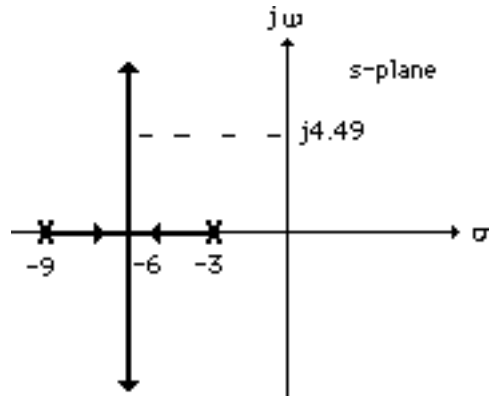

Adding the compensator pole and zero to the system poles, the gain at the design point is found to be

29.16. Summarizing the results:  $G_c(s) = \frac{s+5}{s+9}$  with  $K = 29.16$ .

**19.**

**Lead compensator design:** Searching along the  $120^\circ$  line ( $\zeta = 0.5$ ), find the operating point at

$-1.531 + j2.652$  with  $K = 354.5$ . Thus,  $T_s = \frac{4}{\zeta\omega_n} = \frac{4}{1.531} = 2.61$  seconds. For the settling time to

decrease by 0.5 second,  $T_s = 2.11$  seconds, or  $\text{Re} = -\zeta\omega_n = -\frac{4}{2.11} = -1.9$ . The imaginary part is

$-1.9 \tan 60^\circ = 3.29$ . Hence, the compensated dominant poles are  $-1.9 \pm j3.29$ . The compensator zero

is at  $-5$ . Using the uncompensated system's poles along with the compensator zero, the summation of

angles to the design point,  $-1.9 \pm j3.29$  is  $-166.09^\circ$ . Thus, the contribution of the compensator pole

must be  $166.09^\circ - 180^\circ = -13.91^\circ$ . Using the following geometry,  $\frac{3.29}{p_c - 1.9} = \tan 13.91^\circ$ , or  $p_c =$

15.18.

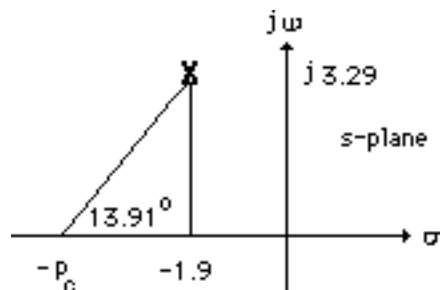

Adding the compensator pole and using  $-1.9 \pm j3.29$  as the test point,  $K = 1417$ .

Computer simulations yield the following: Uncompensated:  $T_s = 3$  seconds, %OS = 14.6%.

Compensated:  $T_s = 2.3$  seconds, %OS = 15.3%.

**Lag compensator design:** The lead compensated open-loop transfer function is

$$G_{LC}(s) = \frac{1417(s+5)}{(s+2)(s+4)(s+6)(s+8)(s+15.18)}. \text{ The uncompensated}$$

$$K_p = 354.5/(2 \times 4 \times 6 \times 8) = 0.923. \text{ Hence, the uncompensated steady-state error is } \frac{1}{1+K_p} = 0.52.$$

Since we want 30 times improvement, the lag-lead compensated system must have a steady-state error of  $0.52/30 = 0.017$ . The lead compensated  $K_p = 1417 \cdot 5 / (2 \cdot 4 \cdot 6 \cdot 8 \cdot 15.18) = 1.215$ . Hence, the

lead-compensated error is  $\frac{1}{1+K_p} = 0.451$ . Thus, the lag compensator must improve the lead-

compensated error by  $0.451/0.017 = 26.529$  times. Thus  $0.451 / (\frac{1}{1+K_{pllc}}) = 26.529$ , where  $K_{pllc} =$

57.823 is the lead-lag compensated system's position constant. Thus, the improvement in  $K_p$  from the lead to the lag-lead compensated system is  $57.823/1.215 = 47.59$ . Use a lag compensator, whose zero

is 47.59 times farther than its pole, or  $G_{lag} = \frac{(s+0.04759)}{(s+0.001)}$ . Thus, the lead-lag compensated open-

$$\text{loop transfer function is } G_{LLC}(s) = \frac{1417(s+5)(s+0.04759)}{(s+2)(s+4)(s+6)(s+8)(s+15.18)(s+0.001)}.$$

## 20.

### Program:

```
numg=1;
deng=poly([-2 -4 -6 -8]);
'G(s)'
G=tf(numg,deng);
Gzpk=zpk(G)
rlocus(G,0:5:500)
z=0.5;
pos=exp(-pi*z/sqrt(1-z^2))*100;
sgrid(z,0)
title(['Uncompensated Root Locus with ', num2str(z), ' Damping Ratio
Line'])
[K,p]=rlocfind(G); %Allows input by selecting point on graphic
'Closed-loop poles = '
p
i=input('Give pole number that is operating point ');
'Summary of estimated specifications for uncompensated system'
operatingpoint=p(i)
gain=K
estimated_settling_time=4/abs(real(p(i)))
estimated_peak_time=pi/abs(imag(p(i)))
estimated_percent_overshoot=pos
estimated_damping_ratio=z
estimated_natural_frequency=sqrt(real(p(i))^2+imag(p(i))^2)
Kpo=dcgain(K*G)
T=feedback(K*G,1);
```

```

'Press any key to continue and obtain the step response'
pause
step(T)

whitebg('w')
title(['Step Response for Uncompensated System with ', num2str(z),...
' Damping Ratio'],'color','black')
'Press any key to go to Lead compensation'
pause
'Compensated system'
b=5;
'Lead Zero at -b '
done=1;
while done>0
a=input('Enter a Test Lead Compensator Pole, (s+a). a = ');
numgglead=[1 b];
dengglead=conv([1 a],poly([-2 -4 -6 -8]));
'G(s)Glead(s)'
GGlead=tf(numgglead,dengglead);
GGleadzpk=zpk(GGlead)
wn=4/((estimated_settling_time-0.5)*z);
clf
rlocus(GGlead,0:10:2000)
sgrid(z,wn)
axis([-10 0 -5 5])
title(['Lead Compensated Root Locus with ', num2str(z),...
' Damping Ratio Line, Lead Pole at ', num2str(-a), ', and Required Wn'])
done=input('Are you done? (y=0,n=1) ');
end
[K,p]=rlocfind(GGlead); %Allows input by selecting point on graphic
'Closed-loop poles = '
p
i=input('Give pole number that is operating point ');
'Summary of estimated specifications for lead-compensated system'
operatingpoint=p(i)
gain=K
estimated_settling_time=4/abs(real(p(i)))
estimated_peak_time=pi/abs(imag(p(i)))
estimated_percent_overshoot=pos
estimated_damping_ratio=z
estimated_natural_frequency=sqrt(real(p(i))^2+imag(p(i))^2)
Kplead=dcgain(K*GGlead)
T=feedback(K*GGlead,1);
'Press any key to continue and obtain the step response'
pause
step(T)

whitebg('w')
title(['Step Response for Lead Compensated System with ', num2str(z),...
' Damping Ratio'],'color','black')
'Press any key to continue and design lag compensation'
pause
'Improvement in steady-state error with lead compensator is'
error_improvement=(1+Kplead)/(1+Kpo)
additional_error_improvement=30/error_improvement
Kpnn=additional_error_improvement*(1+Kplead)-1
pc=0.001
zc=pc*(Kpnn/Kplead)
numggleadlag=conv(numgglead,[1 zc]);
denggleadlag=conv(dengglead,[1 pc]);
'G(s)Glead(s)Glag(s)'
GGleadGlag=tf(numggleadlag,denggleadlag);
GGleadGlagzpk=zpk(GGleadGlag)

```



```

rlocus(GGleadGlag,0:10:2000)
z=0.5;
pos=exp(-pi*z/sqrt(1-z^2))*100;
sgrid(z,0)
title(['Lag-Lead Compensated Root Locus with ', num2str(z), ...
' Damping Ratio Line and Lag Pole at ',num2str(-pc)])
[K,p]=rlocfind(GGleadGlag); %Allows input by selecting point on graphic
'Closed-loop poles = '
p
i=input('Give pole number that is operating point ');
'Summary of estimated specifications for lag-lead compensated system'
operatingpoint=p(i)
gain=K
estimated_settling_time=4/abs(real(p(i)))
estimated_peak_time=pi/abs(imag(p(i)))
estimated_percent_overshoot=pos
estimated_damping_ratio=z
estimated_natural_frequency=sqrt(real(p(i))^2+imag(p(i))^2)
Kpleadlag=dcgain(K*GGleadGlag)
T=feedback(K*GGleadGlag,1);
'Press any key to continue and obtain the step response'
pause
step(T)
whitebg('w')
title(['Step Response for Lag-Lead Compensated System with ',
num2str(z), ...
' Damping Ratio and Lag Pole at ',num2str(-pc)],'color','black')

```

**Computer response:**

ans =

G(s)

Zero/pole/gain:

1

```

-----
(s+8) (s+6) (s+4) (s+2)

```

Select a point in the graphics window

selected\_point =

-1.5036 + 2.6553i

ans =

Closed-loop poles =

p =

-8.4807 + 2.6674i

-8.4807 - 2.6674i

-1.5193 + 2.6674i

-1.5193 - 2.6674i

Give pole number that is operating point 3

ans =

Summary of estimated specifications for uncompensated system

operatingpoint =

-1.5193 + 2.6674i

gain =

360.8014

estimated\_settling\_time =

2.6328

estimated\_peak\_time =

1.1778

estimated\_percent\_overshoot =

16.3034

estimated\_damping\_ratio =

0.5000

estimated\_natural\_frequency =

3.0698

Kpo =

0.9396

ans =

Press any key to continue and obtain the step response

ans =

Press any key to go to Lead compensation

ans =

Compensated system

ans =

Lead Zero at -b

Enter a Test Lead Compensator Pole, (s+a). a = 10

ans =

G(s)Glead(s)

Zero/pole/gain:

(s+5)

-----

(s+10) (s+8) (s+6) (s+4) (s+2)

Are you done? (y=0,n=1) 1  
 Enter a Test Lead Compensator Pole, (s+a). a = 15

ans =

G(s)Glead(s)

Zero/pole/gain:

(s+5)

-----

(s+15) (s+8) (s+6) (s+4) (s+2)

Are you done? (y=0,n=1) 0  
 Select a point in the graphics window

selected\_point =

-1.9076 + 3.2453i

ans =

Closed-loop poles =

p =

-13.0497 + 1.9313i

-13.0497 - 1.9313i

-5.0654

-1.9176 + 3.2514i

-1.9176 - 3.2514i

Give pole number that is operating point 4

ans =

Summary of estimated specifications for lead-compensated system

operatingpoint =

-1.9176 + 3.2514i

gain =

1.3601e+003

estimated\_settling\_time =

2.0860

estimated\_peak\_time =

0.9662

estimated\_percent\_overshoot =

16.3034

estimated\_damping\_ratio =

0.5000

estimated\_natural\_frequency =

3.7747

Kplead =

1.1806

ans =

9-50 Chapter 9: Design via Root Locus

Press any key to continue and obtain the step response

ans =

Press any key to continue and design lag compensation

ans =

Improvement in steady-state error with lead compensator is

error\_improvement =

1.1243

additional\_error\_improvement =

26.6842

Kpnn =

57.1876

pc =

0.0010

zc =

0.0484

ans =

$G(s)G_{lead}(s)G_{lag}(s)$

Zero/pole/gain:

(s+5) (s+0.04844)

-----

(s+15) (s+8) (s+6) (s+4) (s+2) (s+0.001)

Select a point in the graphics window

selected\_point =

-1.8306 + 3.2919i

ans =

Closed-loop poles =

p =

-13.0938 + 2.0650i

-13.0938 - 2.0650i

-5.0623

-1.8617 + 3.3112i

-1.8617 - 3.3112i

-0.0277

Give pole number that is operating point 4

ans =

Summary of estimated specifications for lag-lead compensated system

operatingpoint =

-1.8617 + 3.3112i

gain =

1.4428e+003

estimated\_settling\_time =

2.1486

estimated\_peak\_time =

0.9488

estimated\_percent\_overshoot =

16.3034

estimated\_damping\_ratio =

0.5000

estimated\_natural\_frequency =

3.7987

Kpleadlag =

60.6673

ans =

Press any key to continue and obtain the step response



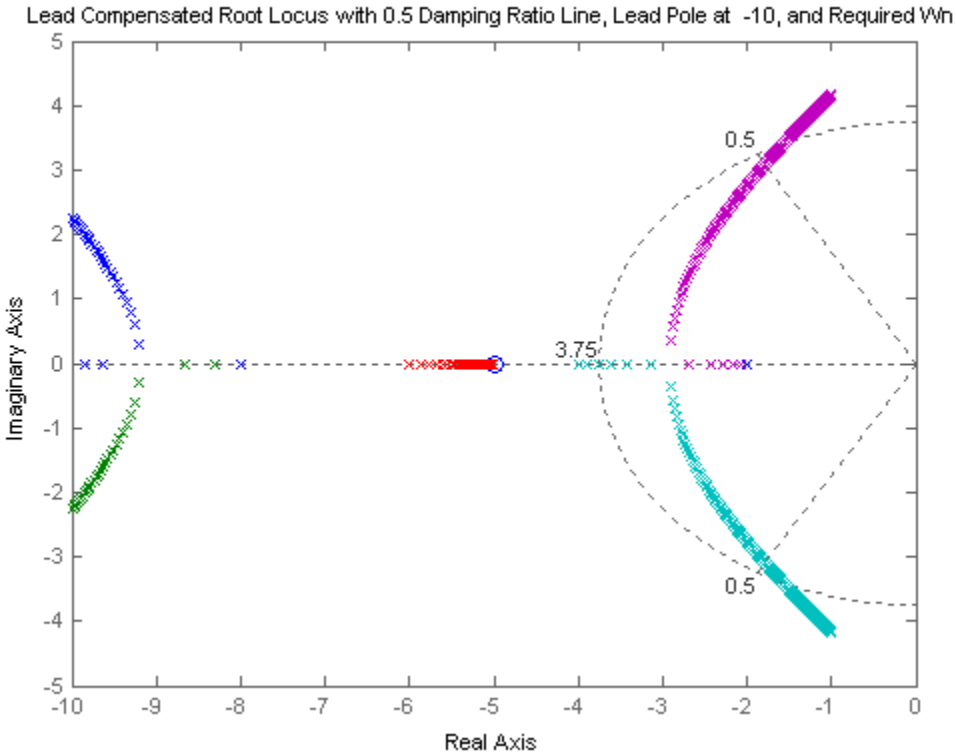
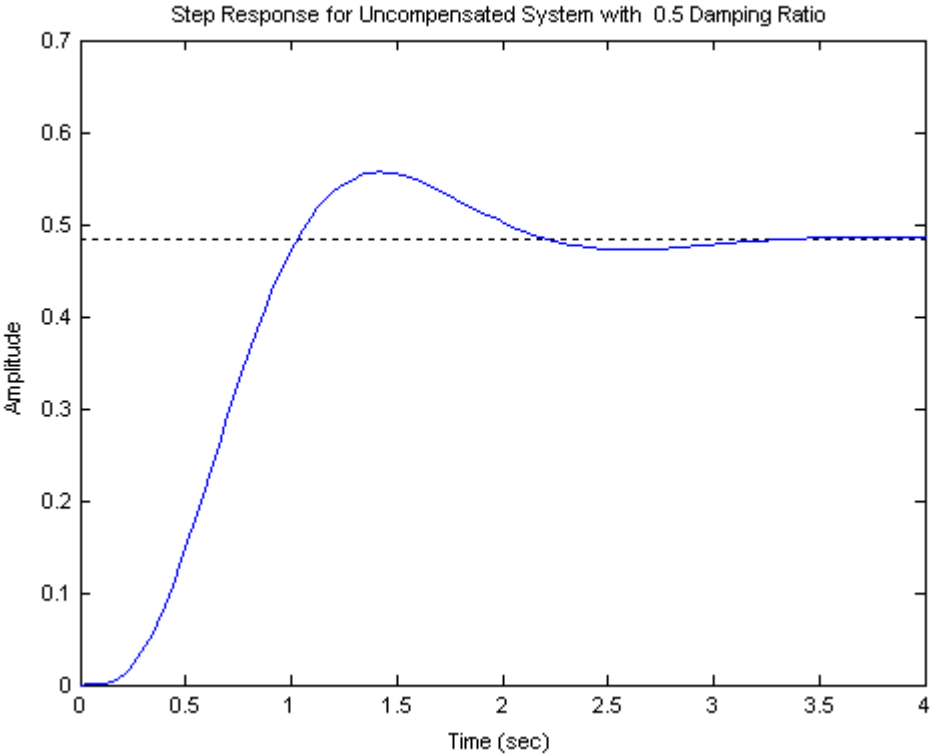

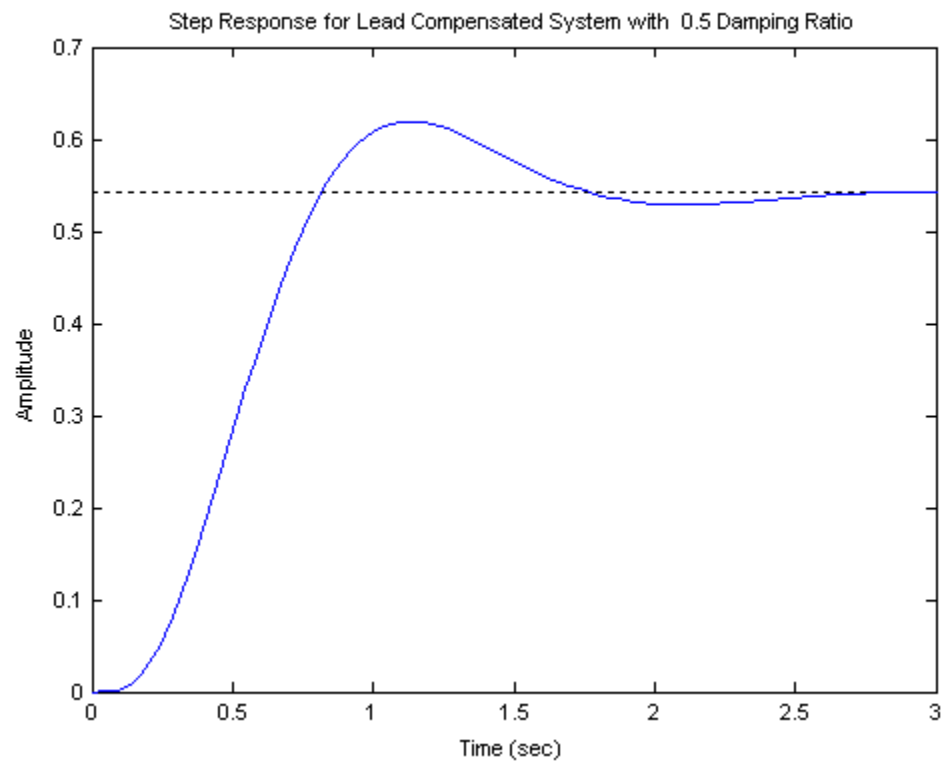
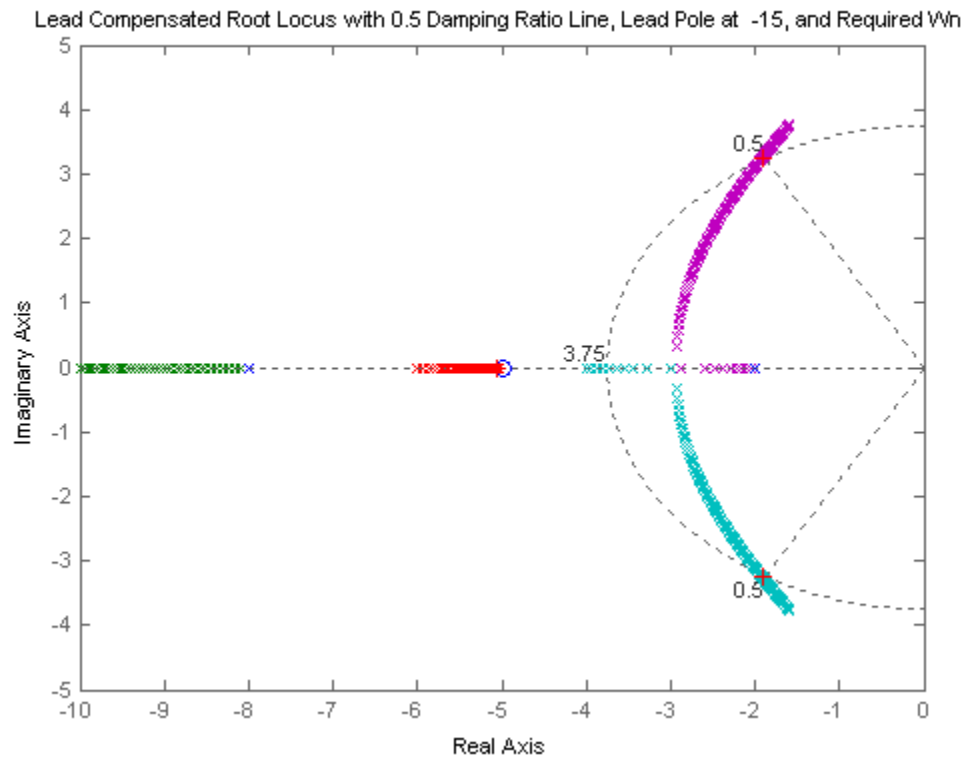

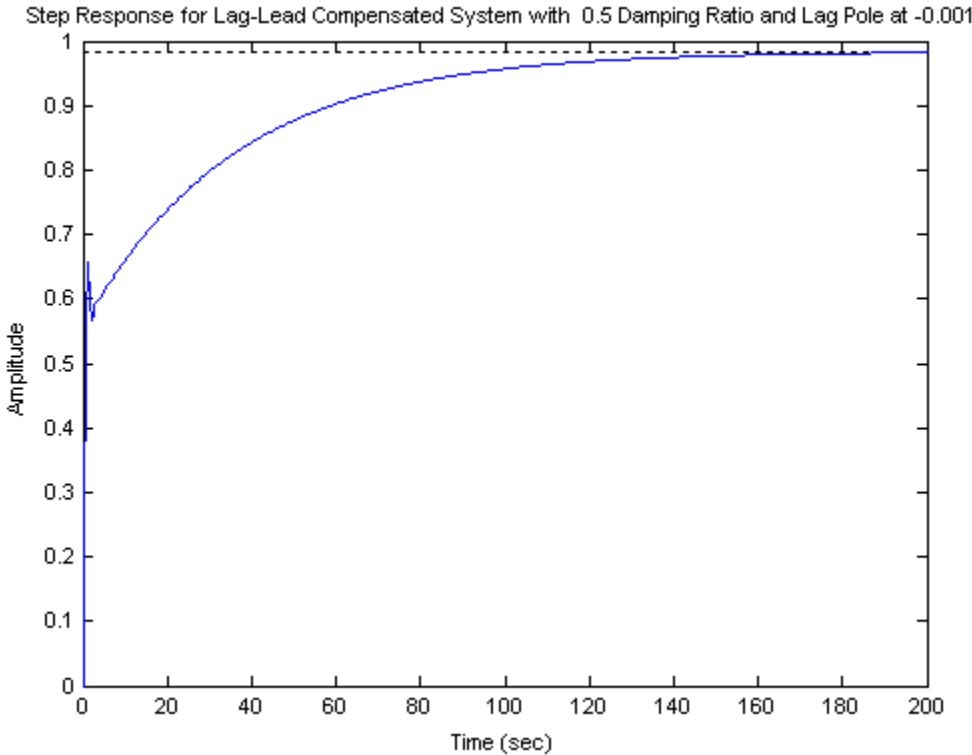
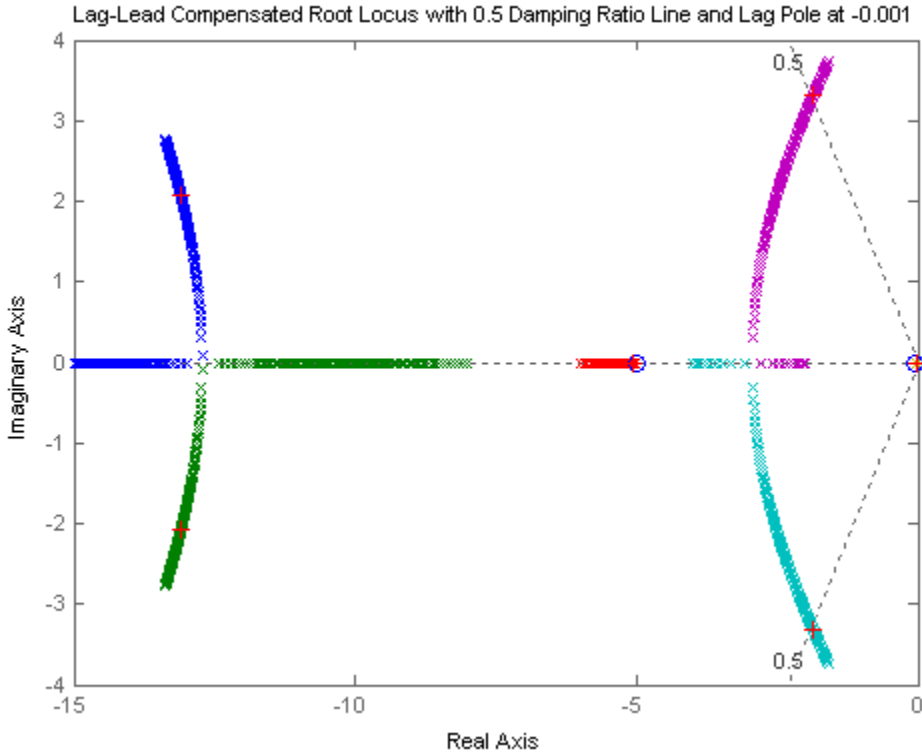

21.

a. For the settling time to be 2.86 seconds with 4.32% overshoot, the real part of the compensated dominant poles must be  $\frac{4}{T_s} = \frac{4}{2.86} = 1.4$ . Hence the compensated dominant poles are  $-1.4 \pm j1.4$ .

Assume the compensator zero to be at -1 canceling the system pole at -1. The summation of angles to the design point at  $-1.4 \pm j1.4$  is  $-176.19^\circ$ . Thus the contribution of the compensator pole is  $176.19^\circ - 180^\circ = 3.81^\circ$ . Using the geometry below,  $\frac{1.4}{p_c - 1.4} = \tan 3.81^\circ$ , or  $p_c = 22.42$ .

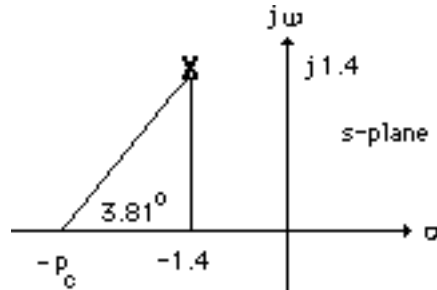

Adding the compensator pole and using  $-1.4 \pm j1.4$  as the test point,  $K = 88.68$ .

b. **Uncompensated:** Search the  $135^\circ$  line (4.32% overshoot) and find the uncompensated dominant pole at  $-0.419 + j0.419$  with  $K = 1.11$ . Thus  $K_v = \frac{1.11}{3} = 0.37$ . Hence,  $T_s = \frac{4}{\zeta\omega_n} = \frac{4}{0.419} = 9.55$  seconds and  $\%OS = 4.32\%$ . **Compensated:**  $K_v = \frac{88.68}{22.42 \times 3} = 1.32$  (Note: steady-state error improvement is greater than 2).  $T_s = \frac{4}{\zeta\omega_n} = \frac{4}{1.4} = 2.86$  seconds and  $\%OS = 4.32\%$ .

c. **Uncompensated:**  $K = 1.11$ ; **Compensated:**  $K = 88.68$ .

d. **Uncompensated:** Searching the real axis segments for  $K = 1.11$  yields a higher-order pole at -3.16 which is more than five times the real part of the uncompensated dominant poles. Thus the second-order approximation for the uncompensated system is valid.

**Compensated:** Searching the real axis segments for  $K = 88.68$  yields a higher-order pole at -22.62 which is more than five times the real part of the compensated dominant poles' real part. Thus the second order approximation is valid.

e.

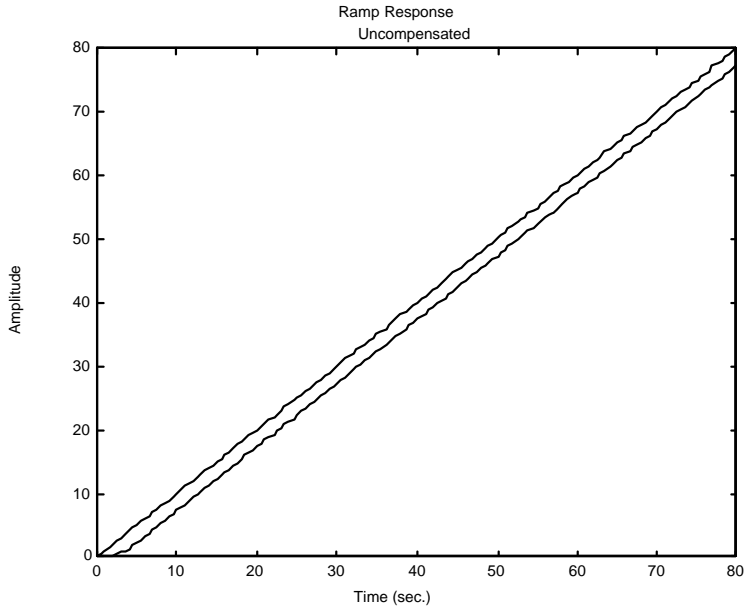
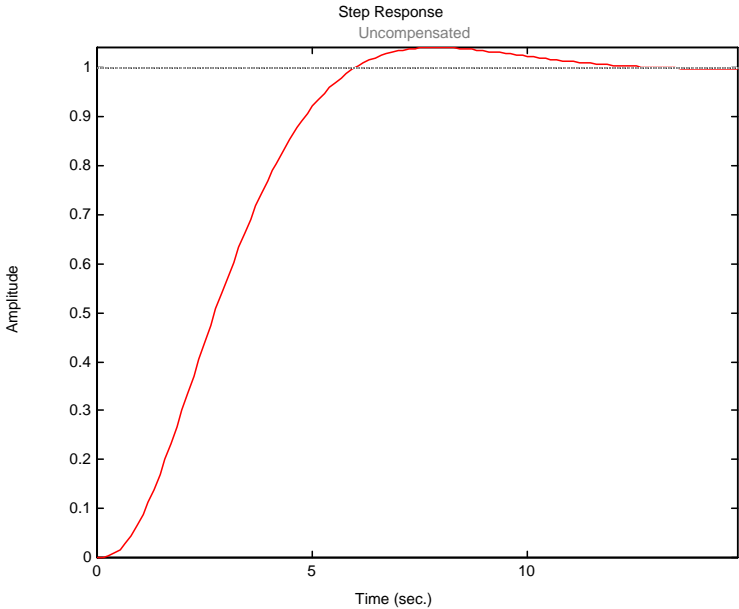

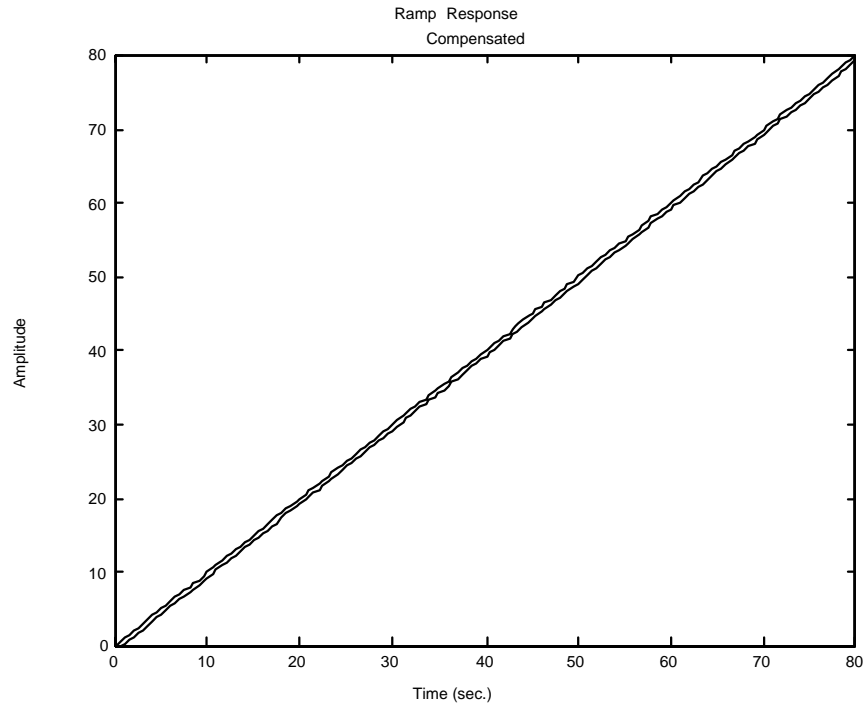
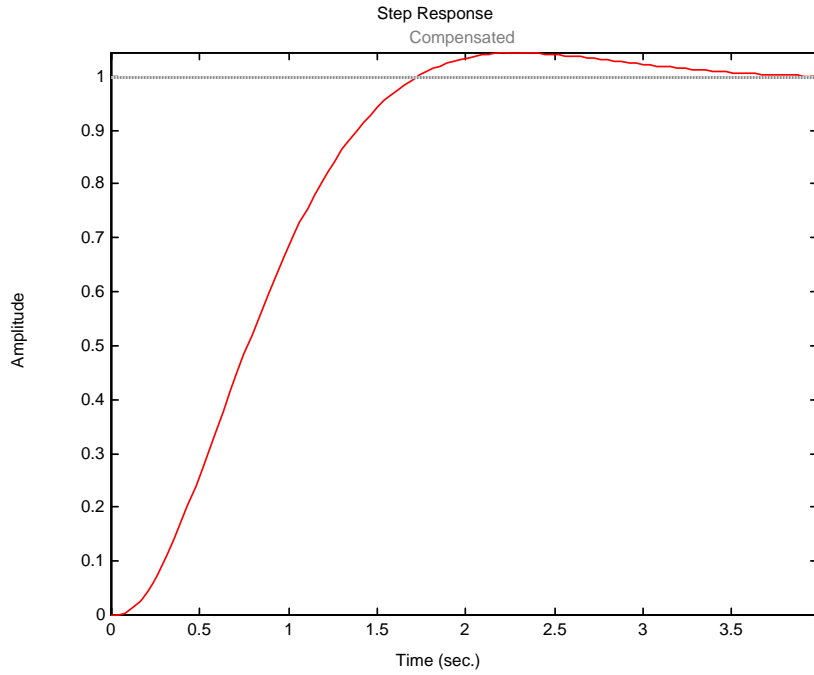

- 22.
- a. Searching the 30% overshoot line ( $\zeta = 0.358$ ;  $110.97^\circ$ ) for  $180^\circ$  yields  $-1.464 + j3.818$  with a gain,  $K = 218.6$ .
  - b.  $T_p = \frac{\pi}{\omega_d} = \frac{\pi}{3.818} = 0.823$  second.  $K_v = \frac{218.6}{(5)(11)} = 3.975$ .
  - c. **Lead design:** From the requirements, the percent overshoot is 15% and the peak time is 0.4115

second. Thus,  $\zeta = \frac{-\ln(\%/100)}{\sqrt{\pi^2 + \ln^2(\%/100)}} = 0.517$ ;  $\omega_d = \frac{\pi}{T_p} = 7.634 = \omega_n \sqrt{1 - \zeta^2}$ . Hence,  $\omega_n = 8.919$ . The design point is located at  $-\zeta\omega_n + j\omega_n\sqrt{1 - \zeta^2} = -4.61 + j7.634$ . Assume a lead compensator zero at  $-5$ . Summing the angles of the uncompensated system's poles as well as the compensator zero at  $-5$  yields  $-171.2^\circ$ . Therefore, the compensator pole must contribute  $(171.2^\circ - 180^\circ) = -8.8^\circ$ . Using the geometry below,

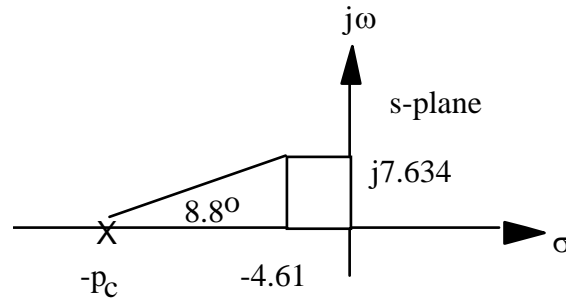

$\frac{7.634}{p_c - 4.61} = \tan(8.8^\circ)$ . Hence,  $p_c = 53.92$ . The compensated open-loop transfer function is  $\frac{K}{s(s+11)(s+53.92)}$ . Evaluating the gain for this function at the point,  $-4.61 + j7.634$  yields

$K = 4430$ .

**Lag design:** The uncompensated  $K_v = \frac{218.6}{(5)(11)} = 3.975$ . The required  $K_v$  is  $30 \cdot 3.975 = 119.25$ .

The lead compensated  $K_v = \frac{4430}{(11)(53.92)} = 7.469$ . Thus, we need an improvement over the lead

compensated system of  $119.25/7.469 = 15.97$ . Thus, use a lag compensator

$G_{\text{lag}}(s) = \frac{s + 0.01597}{s + 0.001}$ . The final open-loop function is  $\frac{4430(s + 0.01597)}{s(s + 11)(s + 53.92)(s + 0.001)}$ .

23.

**a.** Searching along the 10% overshoot line ( $\zeta = 0.591$ ) the operating point is found to be  $-1.85 + j2.53$  with  $K = 21.27$ . A third pole is at  $-10.29$ . Thus, the estimated performance before compensation is: 10% overshoot,  $T_s = \frac{4}{1.85} = 2.16$  seconds, and  $K_p = \frac{21.27}{(8)(10)} = 0.266$ .

**b. Lead design:** Place compensator zero at  $-3$ . The desired operating point is found from the desired specifications.  $\zeta\omega_n = \frac{4}{T_s} = \frac{4}{1} = 4$  and  $\omega_n = \frac{4}{\zeta} = \frac{4}{0.591} = 6.768$ . Thus,

$\text{Im} = \omega_n \sqrt{1 - \zeta^2} = 6.768 \sqrt{1 - 0.591^2} = 5.46$ . Hence the design point is  $-4 + j5.46$ . The angular

contribution of the system poles and compensator zero at the design point is  $-166.96^\circ$ . Thus, the compensator pole must contribute  $-180^\circ + 166.96^\circ = -13.04^\circ$ . Using the geometry below,

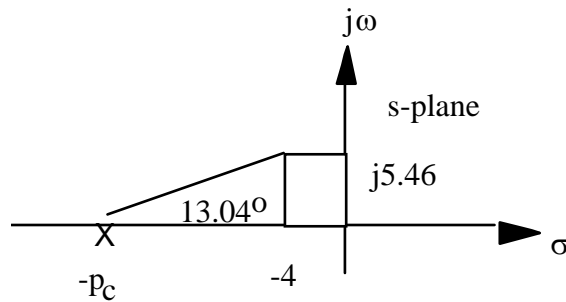

$\frac{5.46}{p_c - 4} = \tan(13.04^\circ)$ . Hence,  $p_c = 27.57$ . The compensated open-loop transfer function is

$$\frac{K(s + 3)}{(s^2 + 4s + 8)(s + 10)(s + 27.57)}$$

Evaluating the gain for this function at the point

$-4 + j5.46$  yields  $K = 1092$  with higher-order poles at  $-4.055$  and  $-29.52$ .

**Lag design:** For the lead-compensated system,  $K_p = 1.485$ . Thus, we need an improvement of

$$\frac{10}{1.485} = 6.734 \text{ times. Hence, } G_{lag}(s) = \frac{(s + 0.06734)}{(s + 0.01)}$$

transfer function is  $G_e(s) = \frac{1092(s + 3)(s + 0.06734)}{(s^2 + 4s + 8)(s + 10)(s + 27.57)(s + 0.01)}$ .

c.

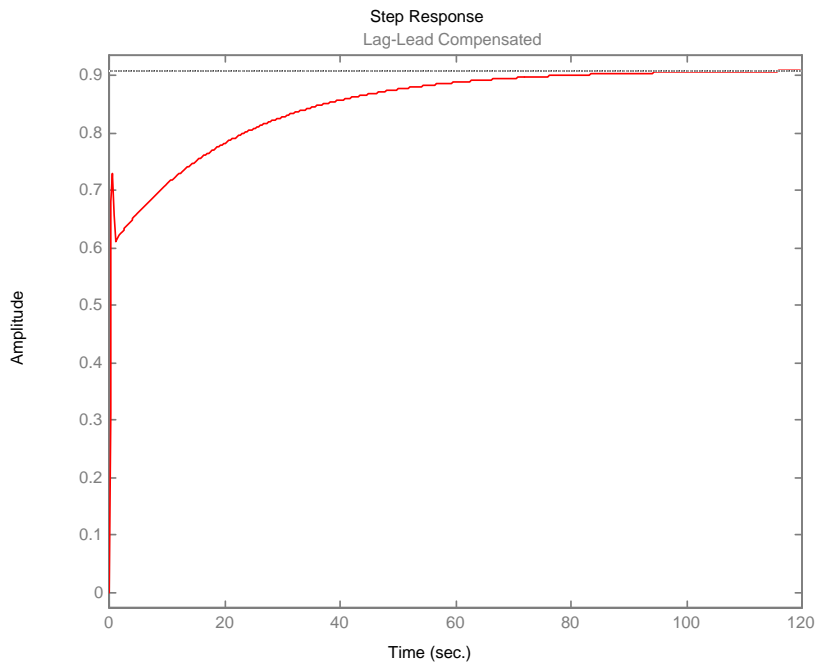



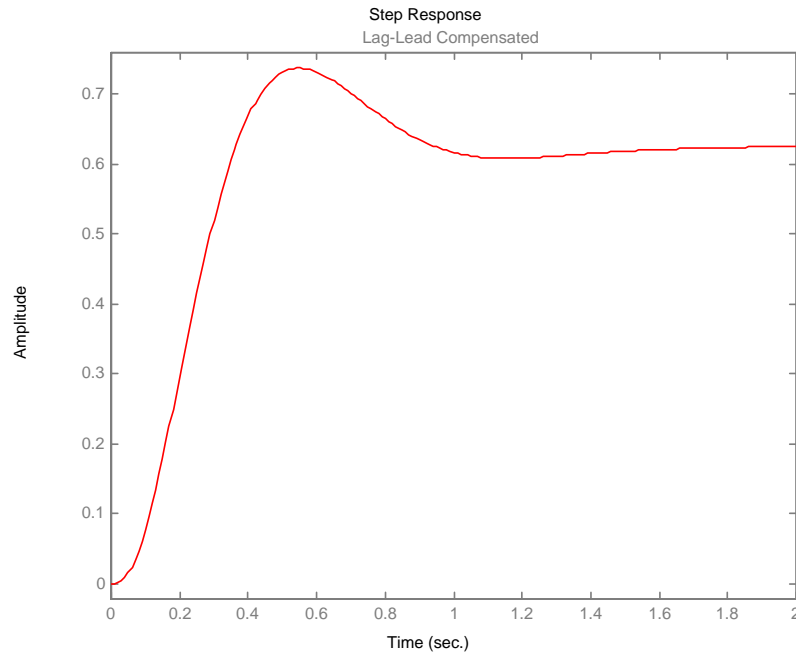

24.

a. Uncompensated: Search the  $135^\circ$  line (4.32% overshoot) for  $180^\circ$  and find the dominant pole at  $-3 + j3$  with  $K = 10$ .

Lag Compensated: Search the  $135^\circ$  line (4.32% overshoot) for  $180^\circ$  and find the dominant pole at  $-2.88 + j2.88$  with  $K = 9.95$ .

b. Uncompensated:  $K_p = \frac{10}{2 \times 4} = 1.25$

Lag compensated:  $K_p = \frac{9.95 \times 0.5}{2 \times 4 \times 0.1} = 6.22$

c. %OS = 4.32% both cases;

Uncompensated  $T_s = \frac{4}{\zeta\omega_n} = \frac{4}{3} = 1.33$  seconds; Compensated  $T_s = \frac{4}{2.88} = 1.39$  seconds

d. Uncompensated: Exact second-order system; approximation OK

Compensated: Search real axis segments of the root locus and find a higher-order pole at  $-0.3$ . System should be simulated to see if there is effective pole/zero cancellation with zero at  $-0.5$ .

e.

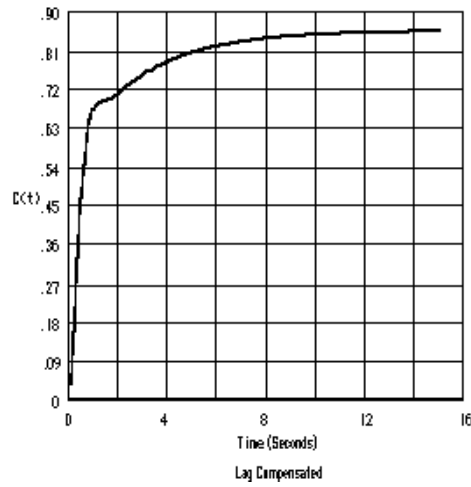
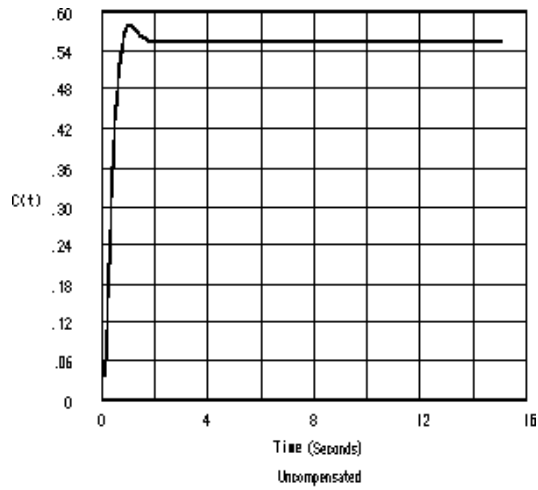

The compensated system's response takes a while to approach the final value.

f. We will design a lead compensator to speed up the system by a factor of 5. The lead-compensated dominant poles will thus be placed at  $-15 \pm j15$ . Assume a compensator zero at  $-4$  that cancels the open-loop pole at  $-4$ . Using the system's poles and the compensator's zero, the sum of angles to the design point,  $-15 \pm j15$  is  $131.69^\circ$ . Thus, the angular contribution of the compensator pole must be  $131.69^\circ - 180^\circ = -48.31^\circ$ . Using the geometry below,  $p_c = 28.36$ .

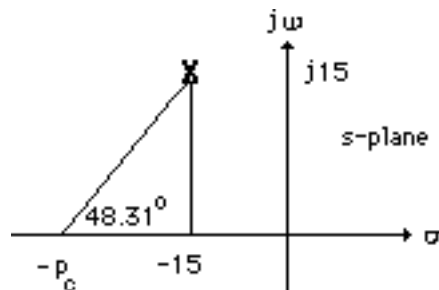

Using the compensated open-loop transfer function,  $G_e(s) = \frac{K(s+0.5)(s+4)}{(s+2)(s+4)(s+0.1)(s+28.36)}$  and using the design point  $-15 \pm j15$ ,  $K = 404.1$ . The time response of the lag-lead compensated system is shown below.

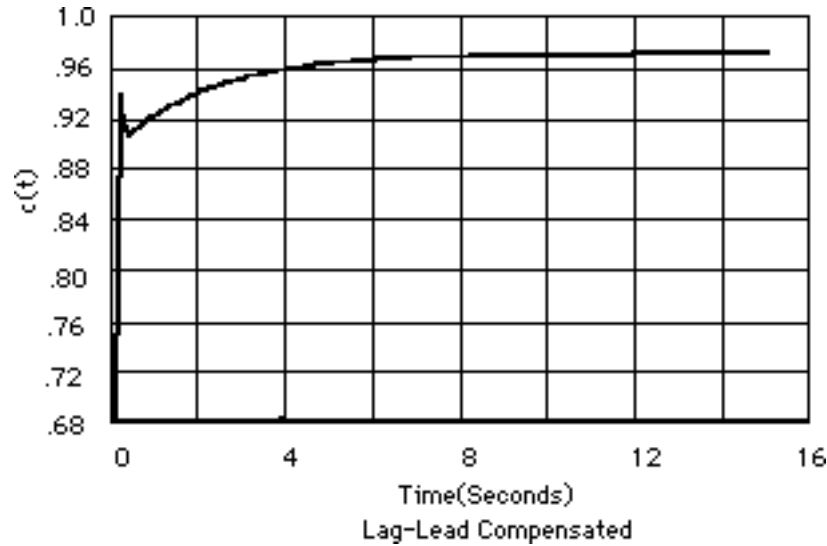

25.

Since  $T_p = 1.047$ , the imaginary part of the compensated closed-loop poles will be  $\frac{\pi}{1.047} = 3$ .

Since  $\frac{\text{Im}}{\text{Re}} = \tan(\cos^{-1}\zeta)$ , the magnitude of the real part will be  $\frac{\text{Im}}{\tan(\cos^{-1}\zeta)} = 4$ . Hence, the design point is  $-4 + j3$ .

Assume an PI controller,  $G_c(s) = \frac{s+0.1}{s}$ , to reduce the steady-state error to zero.

Using the system's poles and the pole and zero of the ideal integral compensator, the summation of angles to the design point is  $-225.7^\circ$ . Hence, the ideal derivative compensator must contribute  $225.7^\circ - 180^\circ = 45.7^\circ$ . Using the geometry below,  $z_c = 6.93$ .

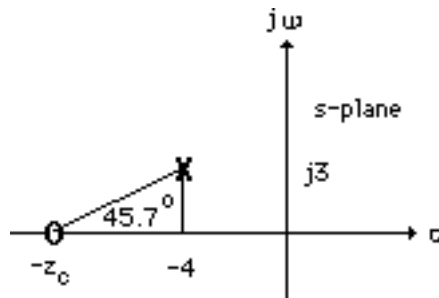

The PID controller is thus  $\frac{(s+6.93)(s+0.1)}{s}$ . Using all poles and zeros of the system and PID

controller, the gain at the design point is  $K = 3.08$ . Searching the real axis segment, a higher-order pole is found at  $-0.085$ . A simulation of the system shows the requirements are met.

26.

a. The desired operating point is found from the desired specifications.  $\zeta\omega_n = \frac{4}{T_s} = \frac{4}{2} = 2$  and

$$\omega_n = \frac{2}{\zeta} = \frac{2}{0.4037} = 4.954. \text{ Thus, } \text{Im} = \omega_n \sqrt{1 - \zeta^2} = 4.954 \sqrt{1 - 0.4037^2} = 4.5324. \text{ Hence}$$

the design point is  $-2 + j4.5324$ . Now, add a pole at the origin to increase system type and drive error to zero for step inputs.

Now design a PD controller. The angular contribution to the design point of the system poles and pole at the origin is  $101.9^\circ$ . Thus, the compensator zero must contribute  $180^\circ - 101.9^\circ = 78.1^\circ$ . Using the geometry below,

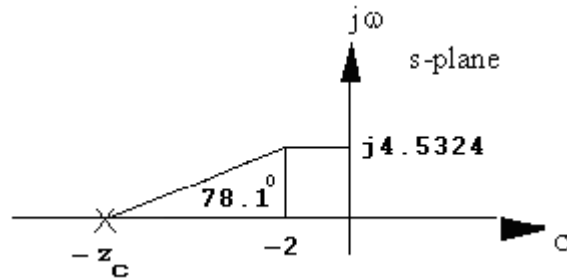

$$\frac{4.5324}{z_c - 2} = \tan(78.1^\circ). \text{ Hence, } z_c = 2.955. \text{ The compensated open-loop transfer function with PD}$$

compensation is  $\frac{K(s + 2.955)}{s(s + 4)(s + 6)(s + 10)}$ . Adding the compensator zero to the system and

evaluating the gain for this at the point  $-2 + j4.5324$  yields  $K = 294.51$  with a higher-order pole at  $-2.66$  and  $-13.34$ .

**PI design:** Use  $G_{PI}(s) = \frac{(s + 0.01)}{s}$ . Hence, the equivalent open-loop transfer function is

$$G_e(s) = \frac{K(s + 2.955)(s + 0.01)}{s^2(s + 4)(s + 6)(s + 10)} \text{ with } K = 294.75.$$

b.

**Program (Step Response):**

```
numg = [-2.995 -0.01];
deng = [0 0 -4 -6 -10];
K = 294.75;
G = zpk(numg, deng, K);
T = feedback(G, 1);
step(T)
```

**Computer response:**

Zero/pole/gain:

$$\frac{294.75 (s+2.995) (s+0.01)}{s^2 (s+4) (s+6) (s+10)}$$

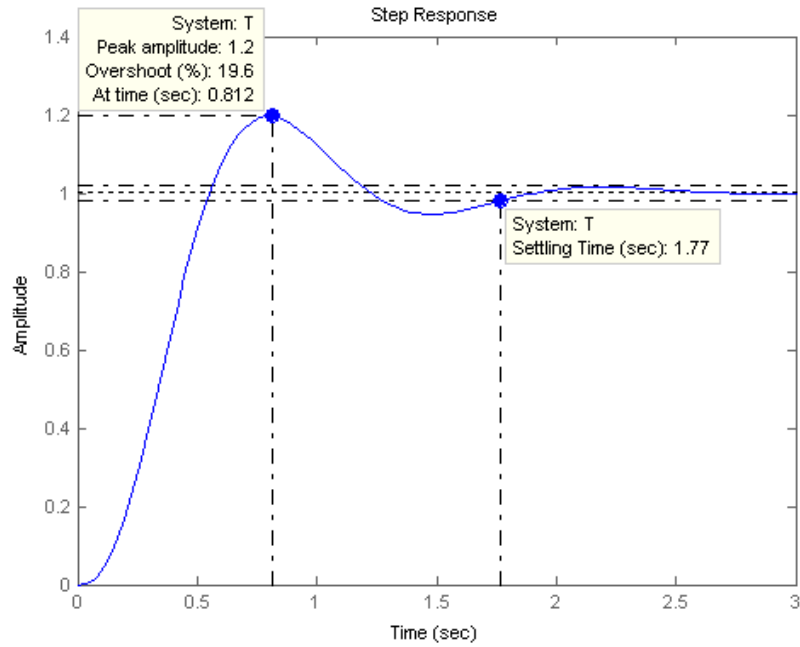
**Program (Ramp Response):**

```
numg=[-2.995 -0.01];
deng=[0 0 -4 -6 -10];
K=294.75;
G=zpk(numg,deng,K)
T=feedback(G,1);
Ta=tf([1],[1 0]);
step(T*Ta)
```

**Computer response:**

Zero/pole/gain:

$$\frac{294.75 (s+2.995) (s+0.01)}{s^2 (s+4) (s+6) (s+10)}$$

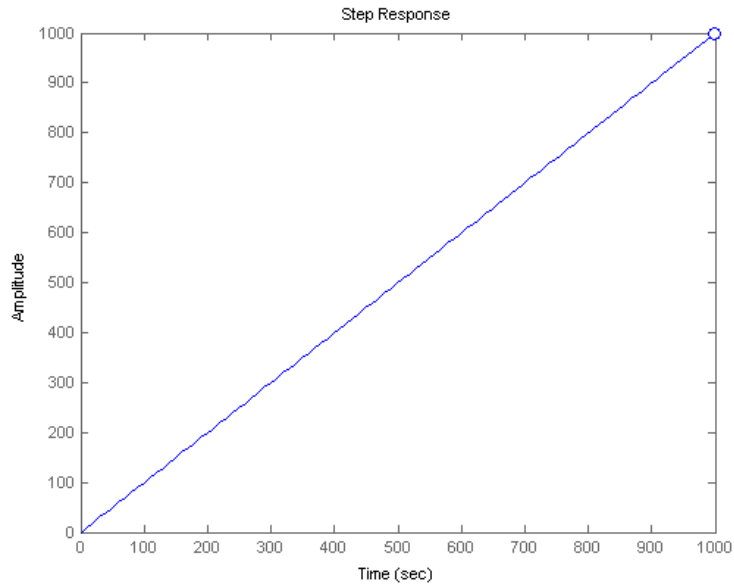

27.

**Program:**

```

numg=[]
deng=[-4 -6 -10]
'G(s)'
G=zpk(numg,deng,1)
pos=input('Type desired percent overshoot ');
z=-log(pos/100)/sqrt(pi^2+[log(pos/100)]^2);
Ts=input('Type desired settling time ');
zci=input(...
'Type desired position of integral controller zero (absolute value) ');
wn=4/(Ts*z);
desired_pole=(-z*wn)+(wn*sqrt(1-z^2)*i)
angle_at_desired_pole=(180/pi)*angle(evalfr(G,desired_pole))
PD_angle=180-angle_at_desired_pole;
zcpd=((imag(desired_pole)/tan(PD_angle*pi/180))-real(desired_pole));
'PD Compensator'
numcpd=[1 zcpd];
dencpd=[0 1];
'Gcpd(s)'
Gcpd=tf(numcpd,dencpd)
Gcpi=zpk([-zci],[0],1)
Ge=G*Gcpd*Gcpi
rlocus(Ge)
sgrid(z,0)
title(['PID Compensated Root Locus with ',...
num2str(pos), '% Damping Ratio Line'])
[K,p]=rlocfind(Ge);
'Closed-loop poles = '
p
f=input('Give pole number that is operating point ');

'Summary of estimated specifications for selected point'
'on PID compensated root locus'

operatingpoint=p(f)
gain=K

```

```

estimated_settling_time=4/abs(real(p(f)))

estimated_peak_time=pi/abs(imag(p(f)))

estimated_percent_overshoot=pos

estimated_damping_ratio=z

estimated_natural_frequency=sqrt(real(p(f))^2+imag(p(f))^2)
T=feedback(K*Ge,1);
step(T)
title(['Step Response for PID Compensated System with ' ,...
      num2str(pos),'% Damping Ratio Line'])
pause
one_over_s=tf(1,[1 0]);
Tr=T*one_over_s;
t=0:0.01:10;
step(one_over_s,Tr)
title('Ramp Response for PID Compensated System')

```

**Computer response:**

```

numg =

      []

deng =

      0      -4      -6      -10

ans =

G(s)

Zero/pole/gain:
      1
-----
s (s+4) (s+6) (s+10)

Type desired percent overshoot 25
Type desired settling time 2
Type desired position of integral controller zero (absolute value) 0.01

desired_pole =

      -2.0000 + 4.5324i

angle_at_desired_pole =

      101.8963

ans =

PD Compensator

ans =

```

Gcpd(s)

Transfer function:  
 $s + 2.955$

Zero/pole/gain:  
 $(s+0.01)$   
 -----  
 $s$

Zero/pole/gain:  
 $(s+2.955) (s+0.01)$   
 -----  
 $s^2 (s+4) (s+6) (s+10)$

Select a point in the graphics window

selected\_point =  
 $-1.9931 + 4.5383i$

ans =

Closed-loop poles =

p =  
 $-13.3485$   
 $-1.9920 + 4.5377i$   
 $-1.9920 - 4.5377i$   
 $-2.6575$   
 $-0.0100$

Give pole number that is operating point 2

ans =

Summary of estimated specifications for selected point

ans =

on PID compensated root locus

operatingpoint =  
 $-1.9920 + 4.5377i$

gain =

$295.6542$

estimated\_settling\_time =



2.0081

estimated\_peak\_time =

0.6923

estimated\_percent\_overshoot =

25

estimated\_damping\_ratio =

0.4037

estimated\_natural\_frequency =

4.9557

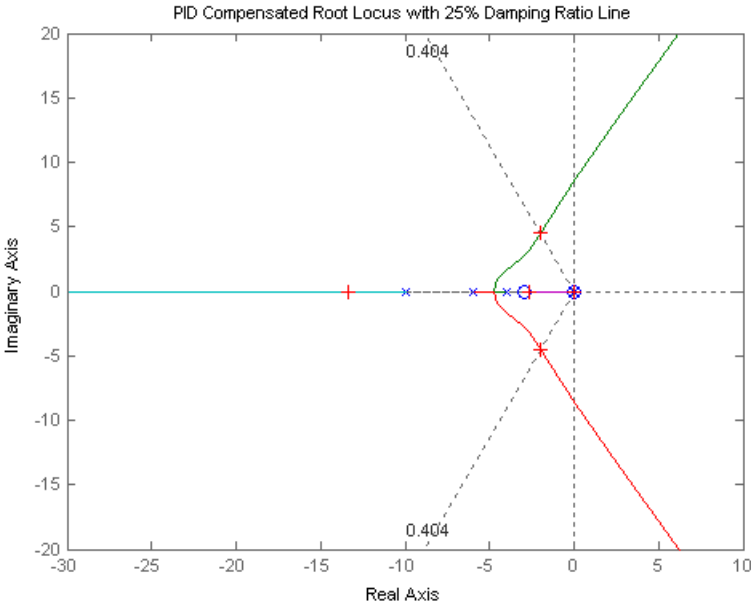

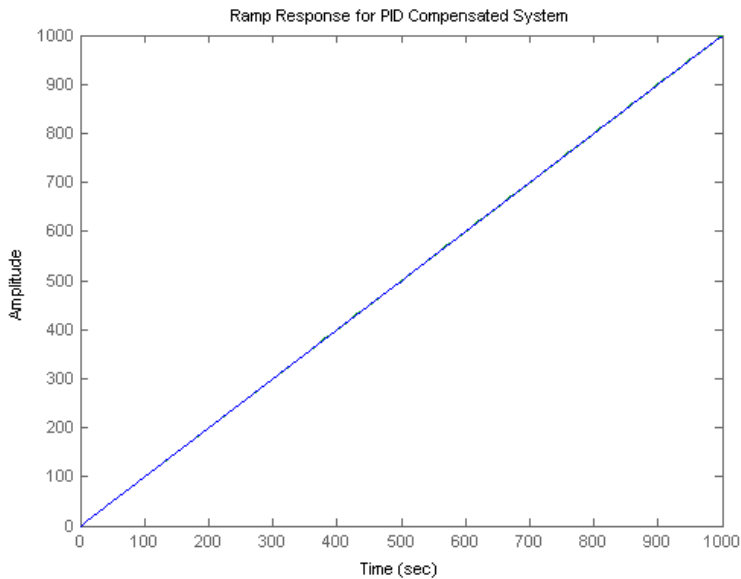
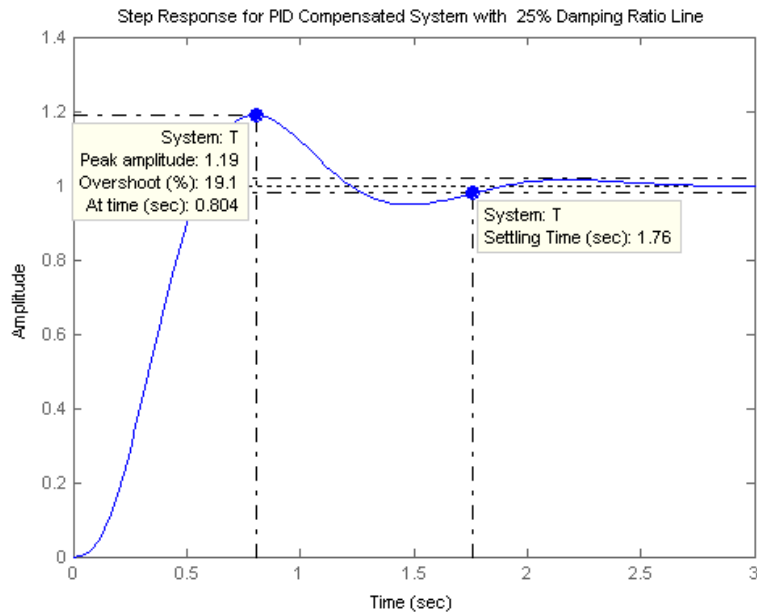

28.

Open-loop poles are at -2, -0.134, and -1.87. An open-loop zero is at -3. Searching the 121.13° line ( $\zeta = 0.517$ ), find the closed-loop dominant poles at  $-0.747 + j1.237$  with  $K = 1.58$ . Searching the real axis segments locates a higher-order pole at -2.51. Since the open-loop zero is a zero of  $H(s)$ , it is not a closed-loop zero. Thus, there are no closed-loop zeros.

29.

a. The damping ratio for 15% overshoot is 0.517. The desired operating point is found from the desired specifications.  $\zeta\omega_n = \frac{4}{T_s} = \frac{4}{3} = 1.333$  and  $\omega_n = \frac{1.333}{\zeta} = \frac{1.333}{0.517} = 2.578$ . Thus,

$\text{Im} = \omega_n \sqrt{1 - \zeta^2} = 2.578 \sqrt{1 - 0.517^2} = 2.207$ . Hence the design point is  $-1.333 + j2.207$ . The angular contribution of the system poles and compensator zero at the design point is  $100.8^\circ$ . Thus, the compensator zero must contribute  $180^\circ - 100.8^\circ = 79.2^\circ$ . Using the geometry below,

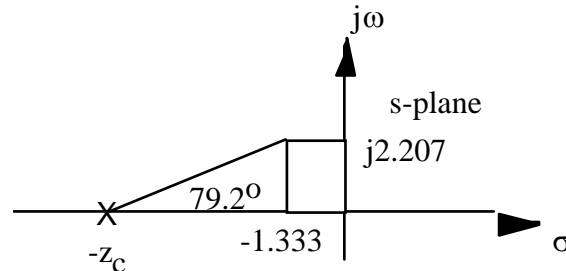

$\frac{2.207}{z_c - 1.333} = \tan(79.2^\circ)$ . Hence,  $z_c = 1.754$ . The compensated open-loop transfer function with PD

compensation is  $\frac{K(s + 1.754)}{s(s + 2)(s + 4)(s + 6)}$ . Evaluating the gain for this function at the point

$-1.333 + j2.207$  yields  $K = 47.28$  with higher-order poles at  $-1.617$  and  $-7.718$ . Following

Figure 9.49(c) in the text,  $\frac{1}{K_f} = 1.754$ . Therefore,  $K_f = 0.5701$ . Also, using the notation of

Figure 9.49(c),  $K_1 K_f = 47.28$ , from which  $K_1 = 82.93$ .

**b.**

**Program:**

```
K1=82.93;
numg=K1;
deng=poly([0 -2 -4 -6]);
'G(s)'
G=tf(numg,deng);
Gzpk=zpk(G)
Kf=0.5701
numh=Kf*[1 1.754];
denh=1
'H(s)'
H=tf(numh,denh);
Hzpk=zpk(H)
'T(s)'
T=feedback(G,H);
T=minreal(T)
step(T)
title('Step Response for Feedback Compensated System')
```

**Computer response:**

ans =

G(s)

```

Zero/pole/gain:
      82.93
-----
s (s+6) (s+4) (s+2)

Kf =

      0.5701

denh =

      1

ans =

H(s)

Zero/pole/gain:
0.5701 (s+1.754)

ans =

T(s)

Transfer function:
              82.93
-----
s^4 + 12 s^3 + 44 s^2 + 95.28 s + 82.93
    
```

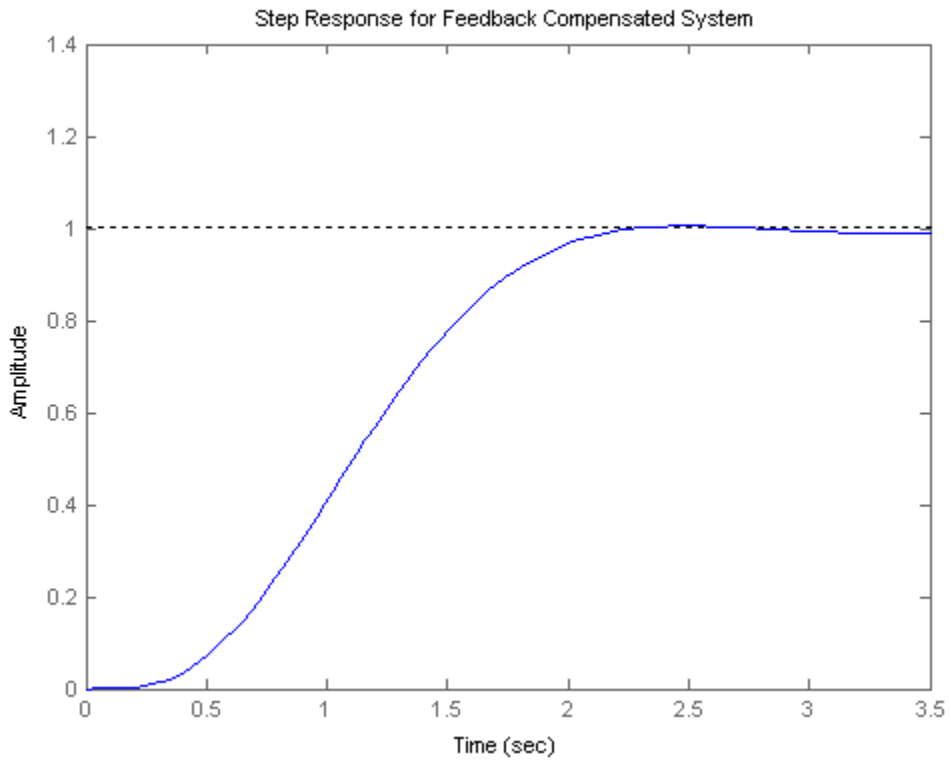

30.

a.  $\sigma_d = \zeta\omega_n = 4/T_s = 4/1 = 4$ . 5% overshoot  $\rightarrow \zeta = 0.69$ . Since  $\zeta\omega_n = 4$ ,  $\omega_n = 5.8$ .

$\omega_d = \omega_n\sqrt{1-\zeta^2} = 4.195$ . Thus, the design point is  $-1 + j4.195$ . The sum of angles from the minor-loop's open-loop poles to the design point is  $-263.634^\circ$ . Thus, the minor-loop's open-loop zero must contribute  $83.634^\circ$  to yield  $180^\circ$  at the design point. Hence,  $\frac{4.195}{z_c - 4} = \tan 83.634^\circ$ , or  $z_c = a = 4.468$  from the geometry below.

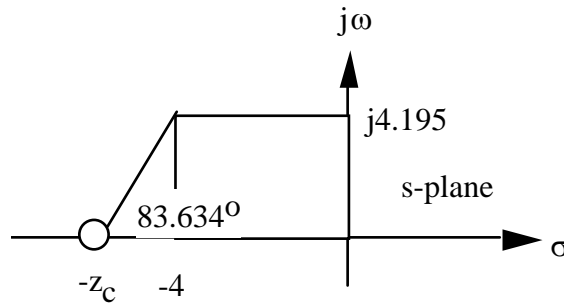

Adding the zero and calculating the gain at the design point yields  $K_1 = 38.33$ . Therefore, the minor-loop open-loop transfer function is  $K_1G(s)H(s) = \frac{38.33(s+4.468)}{s(s+4)(s+9)}$ . The equivalent minor-loop closed-loop transfer function is  $G_{ml}(s) = \frac{K_1G(s)}{1+K_1G(s)H(s)} = \frac{38.33}{s^3+13s^2+74.33s+171.258}$ . A simulation of the step response of the minor loop is shown below.

**Computer response:**

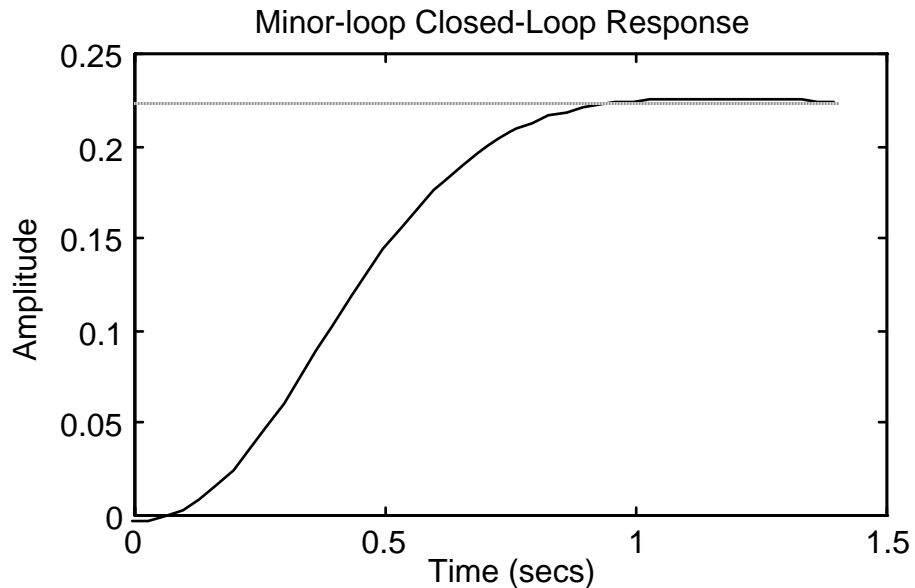

b. The major-loop open-loop transfer function is  $G_e(s) = \frac{38.33K}{s^3 + 13s^2 + 74.33s + 171.258}$ .

Drawing the root locus using  $G_e(s)$  and searching along the 10% overshoot line ( $\zeta = 0.591$ ) for  $180^\circ$  yields the point  $-3.349 + j4.572$  with a gain  $38.33K = 31.131$ , or  $K = 0.812$ .

c.

**Program:**

```
numg=31.131;
deng=[1 13 74.33 171.258];
'G(s)'
G=tf(numg,deng)
T=feedback(G,1);
step(T)
title('Major-loop Closed-Loop Response')
```

**Computer response:**

```
G(s)

Transfer function:
      31.13
-----
s^3 + 13 s^2 + 74.33 s + 171.3
```

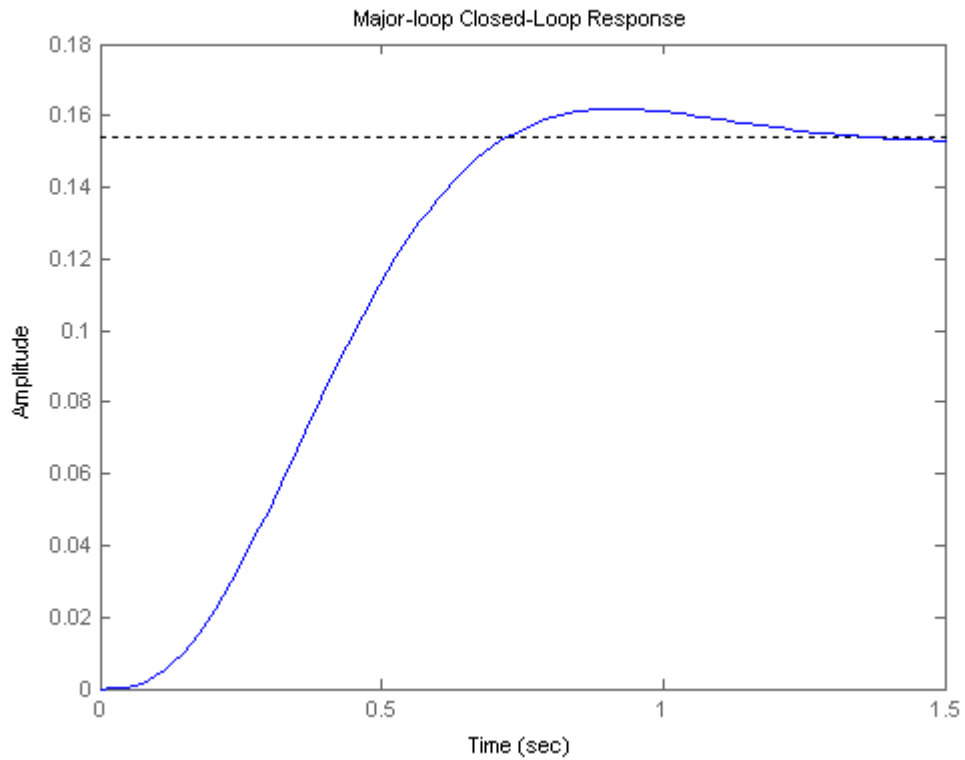

d. Adding the PI compensator,  $G_e(s) = \frac{31.131(s+0.1)}{s(s^3+13s^2+74.33s+171.258)}$ .

**Program:**

```

numge=31.131*[1 0.1];
denge=[1 13 74.33 171.258 0];
'Ge(s)'
Ge=tf(numge,denge)
T=feedback(Ge,1);
t=0:0.1:10;
step(T,t)
title('Major-loop Closed-Loop Response with PI Compensator')
pause
step(T)
title('Major-loop Closed-Loop Response with PI Compensator')

```

**Computer response:**

```
ans =
```

```
Ge(s)
```

```
Transfer function:
```

```
31.13 s + 3.113
```

```
-----
s^4 + 13 s^3 + 74.33 s^2 + 171.3 s
```

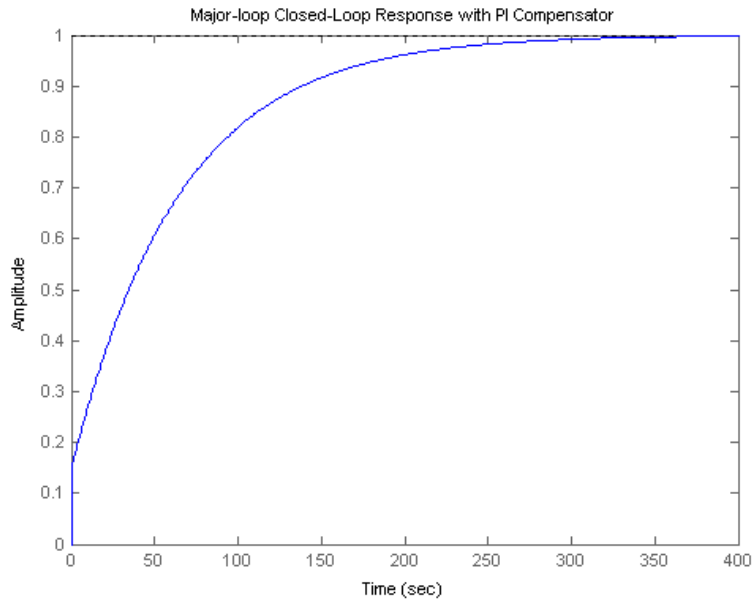
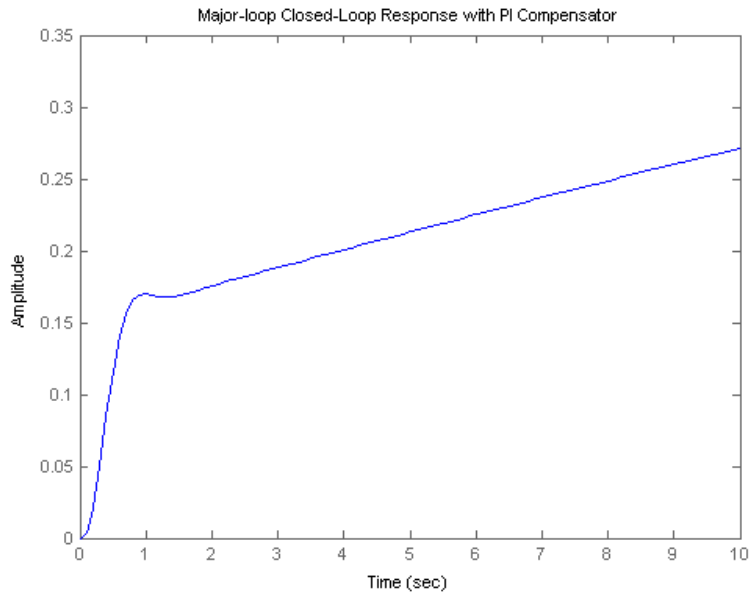

31.

**a. PI controller:** Using Table 9.10,  $\frac{R_2}{R_1} \frac{s + \frac{1}{R_2 C}}{s} = \frac{s + 0.01}{s}$ ,  $R_2 C = 100$ . Let  $C = 25 \mu\text{F}$ . Therefore,  $R_2 = 4 \text{ M}\Omega$ . For unity gain,  $R_1 = 4 \text{ M}\Omega$ . Compensate elsewhere in the loop for the compensator negative sign.



**b. PD controller:** Using Table 9.10,  $R_2C(s + \frac{1}{R_1C}) = s+2$ . Hence,  $R_1C = 0.5$ . Let  $C = 1 \mu\text{F}$ .

Therefore,  $R_1 = 500 \text{ K}\Omega$ . For unity gain,  $R_2C = 1$ , or  $R_2 = 1 \text{ M}\Omega$ . Compensate elsewhere in the loop for the compensator negative sign.

32.

**a. Lag compensator:** See Table 9.11.  $\frac{s + \frac{1}{R_2C}}{s + \frac{1}{(R_1 + R_2)C}} = \frac{s + 0.1}{s + 0.01}$ . Thus,  $R_2C = 10$ , and

$(R_1 + R_2)C = 100$ . Letting  $C = 10 \mu\text{F}$ , we find  $R_2 = 1 \text{ M}\Omega$ . Also  $R_1C = 100 - R_2C = 90$ , which yields  $R_1 = 9 \text{ M}\Omega$ . The loop gain also must be multiplied by  $\frac{R_1 + R_2}{R_2}$ .

**b. Lead compensator:** See Table 9.11.  $\frac{s + \frac{1}{R_1C}}{s + \frac{1}{R_1C} + \frac{1}{R_2C}} = \frac{s+2}{s+5}$ . Thus,  $R_1C = 0.5$ , and

$\frac{1}{R_1C} + \frac{1}{R_2C} = 5$ . Letting  $C = 1 \mu\text{F}$ ,  $R_2 = 333 \text{ K}\Omega$ , and  $R_1 = 500 \text{ K}\Omega$ .

**c. Lag-lead compensation:** See Table 9.11.

$\frac{(s + \frac{1}{R_1C_1})(s + \frac{1}{R_2C_2})}{s^2 + (\frac{1}{R_1C_1} + \frac{1}{R_2C_2} + \frac{1}{R_2C_1})s + \frac{1}{R_1R_2C_1C_2}} = \frac{(s+0.1)(s+1)}{s^2 + 10.01s + 0.1}$ . Thus,  $R_1C_1 = 1$ , and

$R_2C_2 = 10$ . Also,  $\frac{1}{R_1C_1} + \frac{1}{R_2C_2} + \frac{1}{R_2C_1} = 1 + 0.1 + \frac{1}{R_2C_1} = 10.01$ , or  $R_2C_1 = 0.112$ . Letting  $C_1 = 10 \mu\text{F}$ , we find  $R_1 = 10 \text{ M}\Omega$ ,  $R_2 = 1.12 \text{ M}\Omega$ , and  $C_2 = 8.9 \mu\text{F}$ .

33.

**a. Lag compensator:** See Table 9.10 and Figure 9.58.  $\frac{s+0.1}{s+0.01} = \frac{C_1}{C_2} \frac{(s + \frac{1}{R_1C_1})}{(s + \frac{1}{R_2C_2})}$ . Therefore,

$R_1C_1 = 10$ ;  $R_2C_2 = 100$ . Letting  $C_1 = C_2 = 20 \mu\text{F}$ , we find  $R_1 = 500 \text{ K}\Omega$  and  $R_2 = 5 \text{ M}\Omega$ .

Compensate elsewhere in the loop for the compensator negative sign.

**b. Lead compensator:** See Table 9.10 and Figure 9.58.  $\frac{s+2}{s+5} = \frac{C_1}{C_2} \frac{(s + \frac{1}{R_1C_1})}{(s + \frac{1}{R_2C_2})}$ . Therefore,

$R_1C_1 = 0.5$  and  $R_2C_2 = 0.2$ . Letting  $C_1 = C_2 = 20 \mu\text{F}$ , we find  $R_1 = 25 \text{ K}\Omega$  and  $R_2 = 10 \text{ M}\Omega$ .

Compensate elsewhere in the loop for the compensator negative sign.

**c. Lag-lead compensator:** See Table 9.10 and Figure 9.58. For lag portion, use (a). For lead:

$$\frac{s+1}{s+10} = \frac{C_1}{C_2} \frac{(s+\frac{1}{R_1C_1})}{(s+\frac{1}{R_2C_2})}. \text{ Therefore, } R_1C_1 = 1 \text{ and } R_2C_2 = 0.1. \text{ Letting } C_1 = C_2 = 10 \mu\text{F, we find}$$

$R_1 = 100 \text{ K}\Omega$  and  $R_2 = 10 \text{ K}\Omega$ . The following circuit can be used to implement the design.

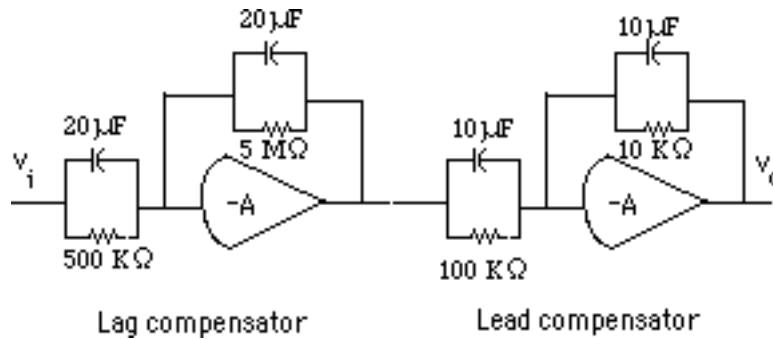

## SOLUTIONS TO DESIGN PROBLEMS

34.

a.  $K_p = \lim_{s \rightarrow 0} G(s) = 7.5184 \times 10^{-3}$  The steady state error for a unit step input is

$$e_{ss} = \frac{1}{1 + K_p} = 0.9925$$

b. The conventional PI design cannot be carried on because all the closed loop roots are on the real axis. Adding a pole-zero pair close to the origin will add a dominant closed loop pole very close to the imaginary axis increasing significantly the system's settling time.

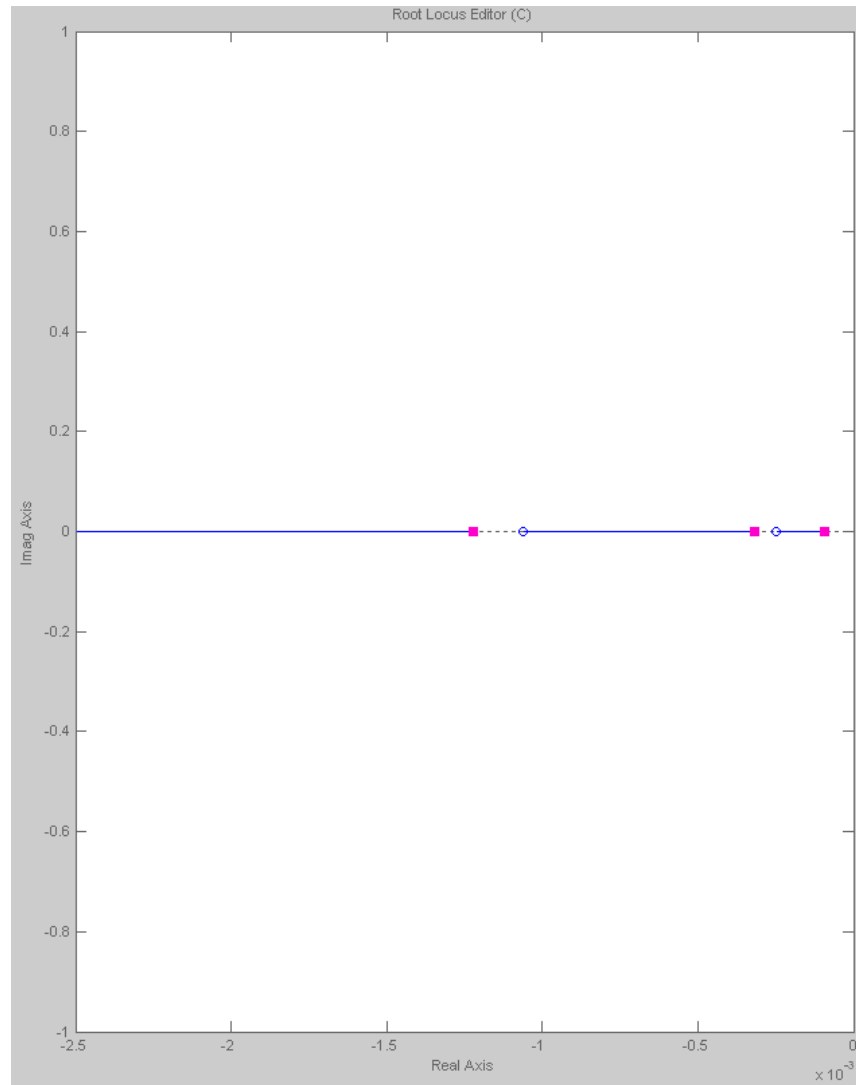

- c. One possibility is to add the pole at the origin to increase the system's type, and add the compensator zero immediately to the left of the rightmost open loop pole. For the plant the open loop zeros are: -0.00025, -0.00164. The open loop poles are: -0.000092, -0.0032 and -0.00122. Thus the compensator will be of the form  $G_C(s) = \frac{K(s + 0.0001)}{s}$ . This will modify the root locus as shown. However the gain can be adjusted to preserve the original pole locations without increasing much the overall system's settling time. Using Sisotool  $K = 0.04$  was found as suitable.

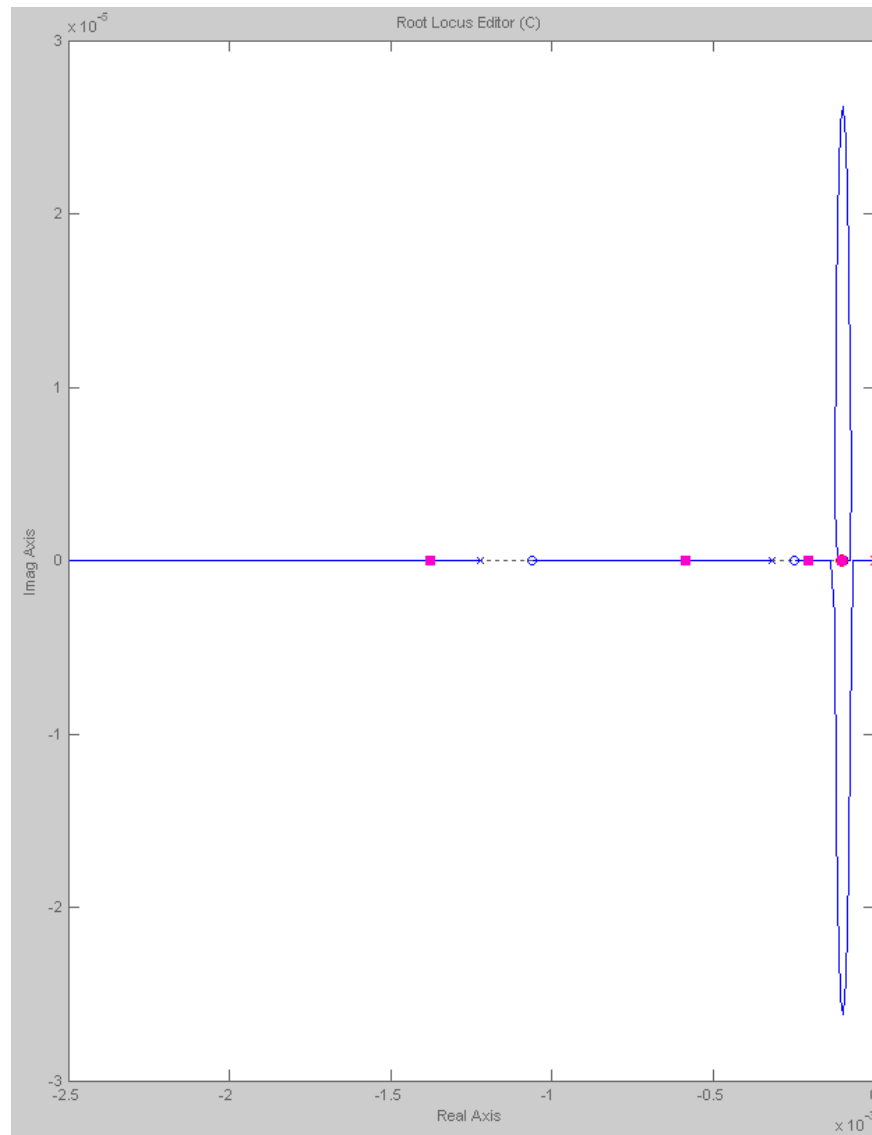

d. The Simulink model is

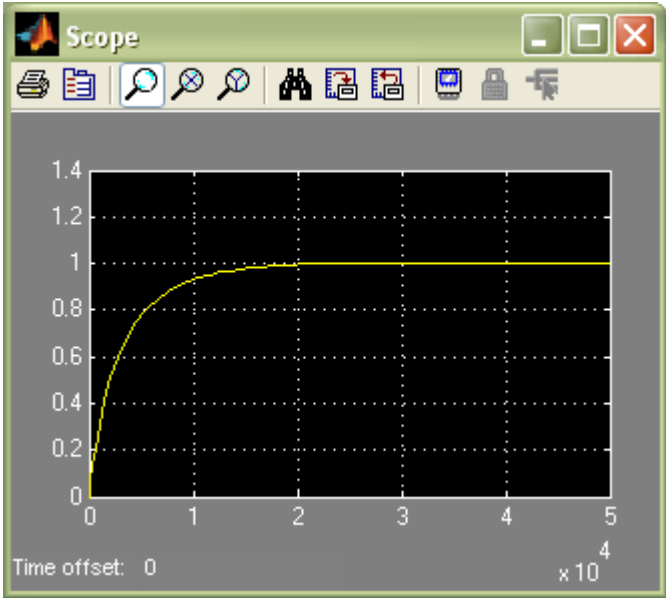
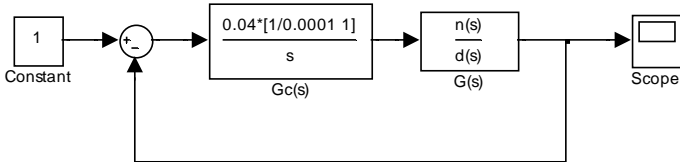

Simulation with  $G_C(s) = \frac{0.04(1 + s/0.0001)}{s}$

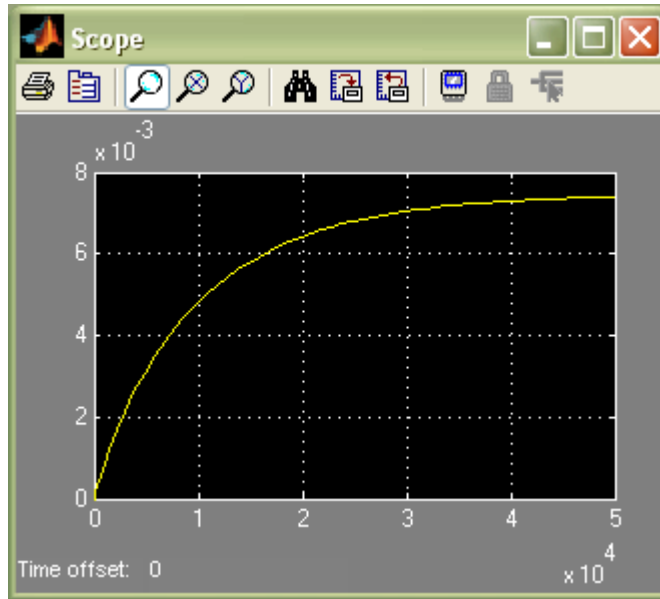

Simulation with  $G_c(s) = 1$

35.

With  $G_c(s) = 1$ ,  $K_{po} = \lim_{s \rightarrow 0} G(s) = 2.06$  giving  $e_{ss} = \frac{1}{1 + K_{po}} = 0.32$ . The root locus is:

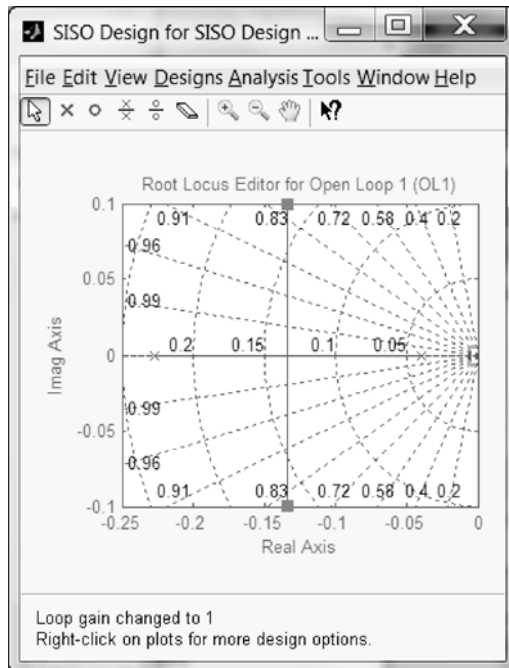

Note that the damping factor  $\xi = 0.8$

We start by calculating the required  $K_{ps}$  from the steady state error requirement

$$e_{ss} = \frac{1}{1 + K_{ps}} = 0.1 \text{ or } K_{ps} = 9. \text{ So } \frac{z_c}{p_c} = \frac{K_{ps}}{K_{po}} = \frac{9}{2.06} = 4.369. \text{ Arbitrarily let}$$

$z_c = 0.035$  which gives  $p_c = 0.008$ . Then the loop gain is adjusted to obtain  $\xi = 0.8$ , but did

not change much in this design. We have  $G_C(s) = \frac{(s + 0.035)}{(s + 0.008)}$ . The root locus is:

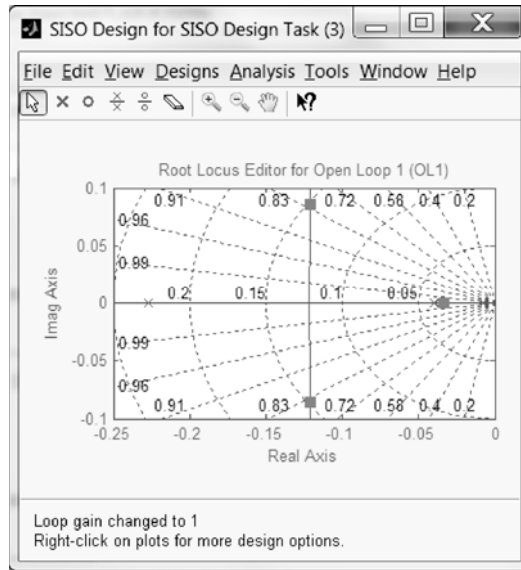

The time domain simulation can be done as follows:

```
>> syms s
>> s=tf('s');
>> G=0.0187/(s^2+0.267*s+0.00908);
>> Gc=(s+0.035)/(s+0.008);
>> T1=G/(1+G);
>> T2=G*C/(1+G*C);
>> step(T1,T2)
```

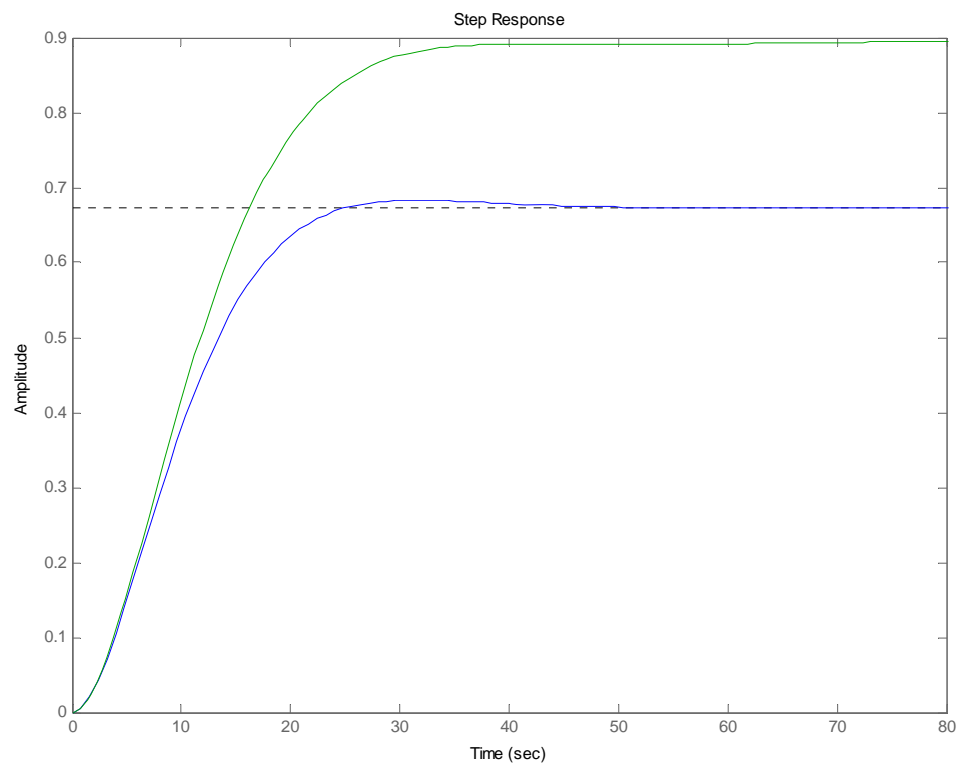

**36.**

a. The system's root locus shows that  $\zeta = 0.7$  is achieved when  $K = 1.11$ , with a corresponding

$T_s = \frac{4}{\zeta\omega_n} = 90.1 \text{ sec}$ . At this value of gain the system has dominant poles at

$-0.0444 \pm j0.0453$  and a third pole at  $-0.265$  justifying the dominant pole approximation.



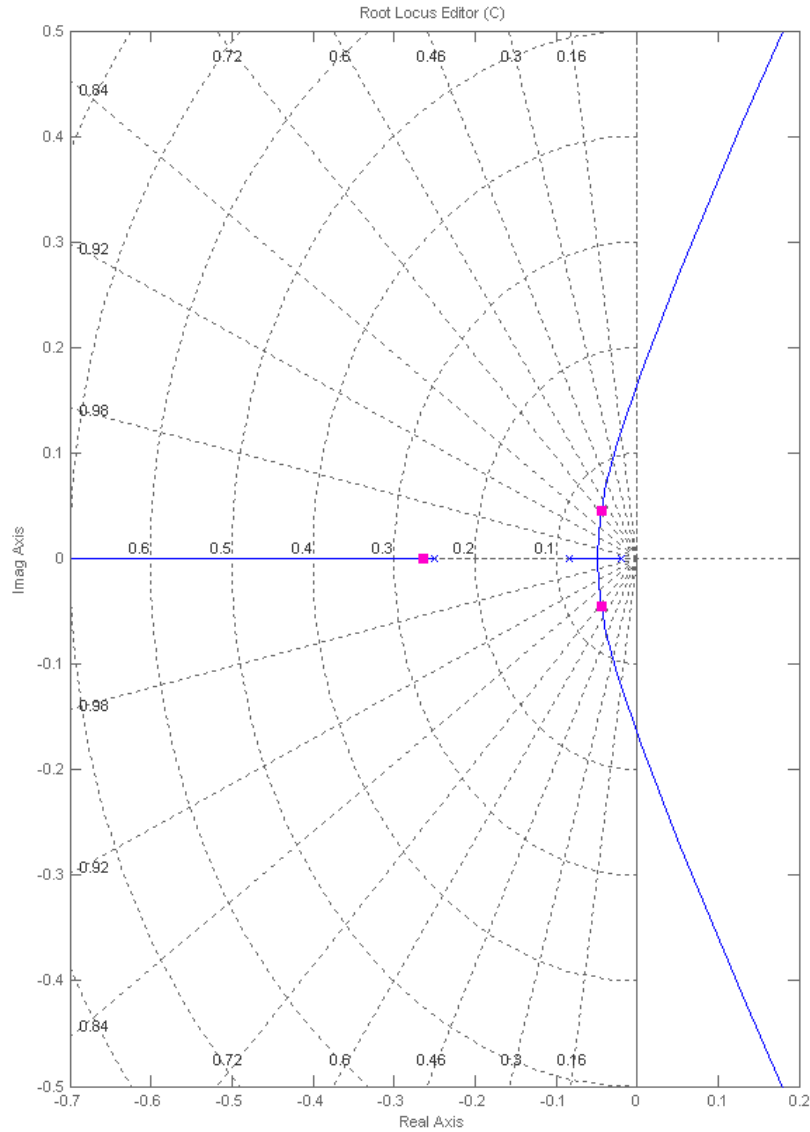

- b. We calculate the desired closed loop positions. The desired  $T_c = 72.1$  sec so the real part of the poles is  $\sigma = \frac{4}{72.1} = 0.55$ . Since we want to maintain  $\xi = 0.7$ , the imaginary part is found from  $\tan 45.6^\circ = \frac{\omega_d}{0.055}$  resulting in  $\omega_d = 0.056$ . So the desired closed loop poles are  $-0.055 \pm j0.056$ . The compensator has the form  $G_C(s) = K(s + z_c)$ . A search using MATLAB's sisotool gives  $z_c = -0.178$  with  $K = 11.424$ . The resulting root locus is

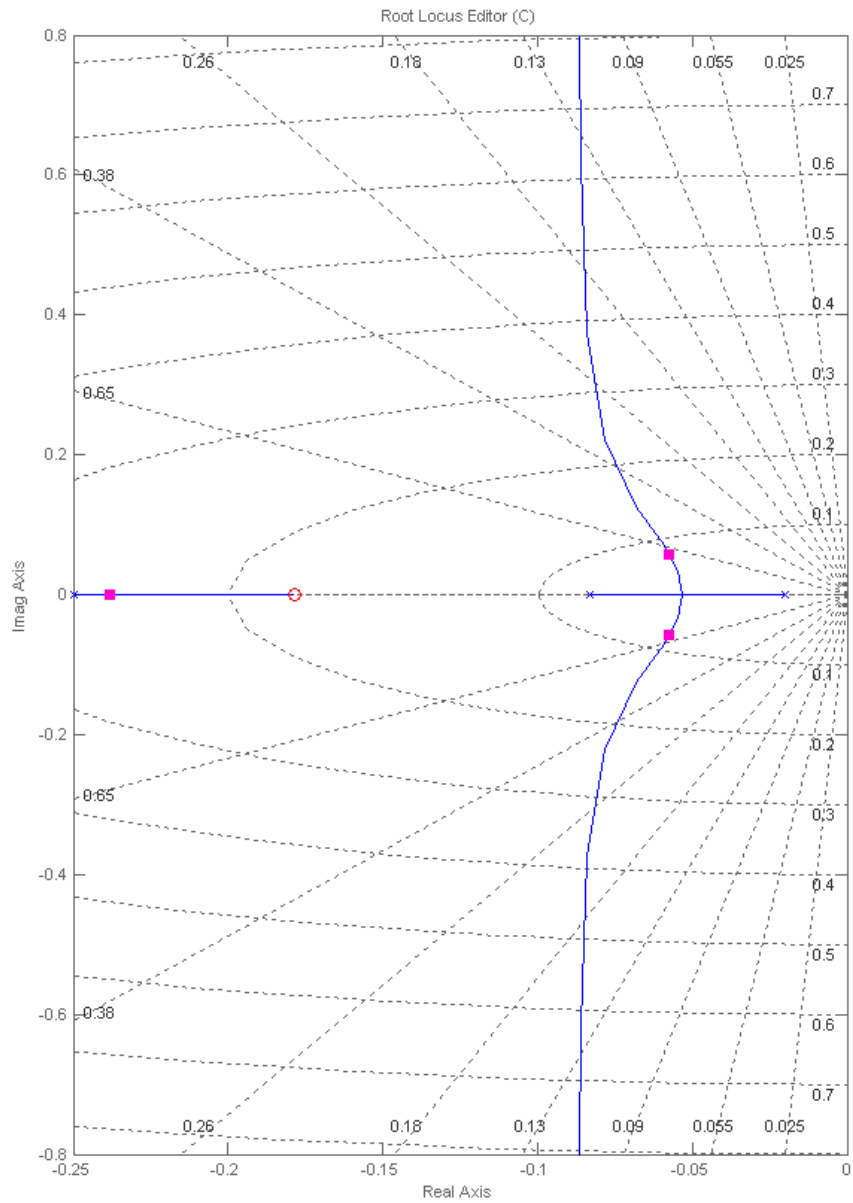

**c.**

```
>> syms s
>> s=tf('s');
>> Gv = 0.02/(4*s+1);
>> G1 = 70/(50*s+1);
>> H = 1/(12*s+1);
>> G = Gv*G1';
>> T=1.11*G/(1+1.11*G*H);
```

```

>> C=11.424*(s+0.178);
>> T2=C*G/(1+C*G*H);
>> step(T,T2)

```

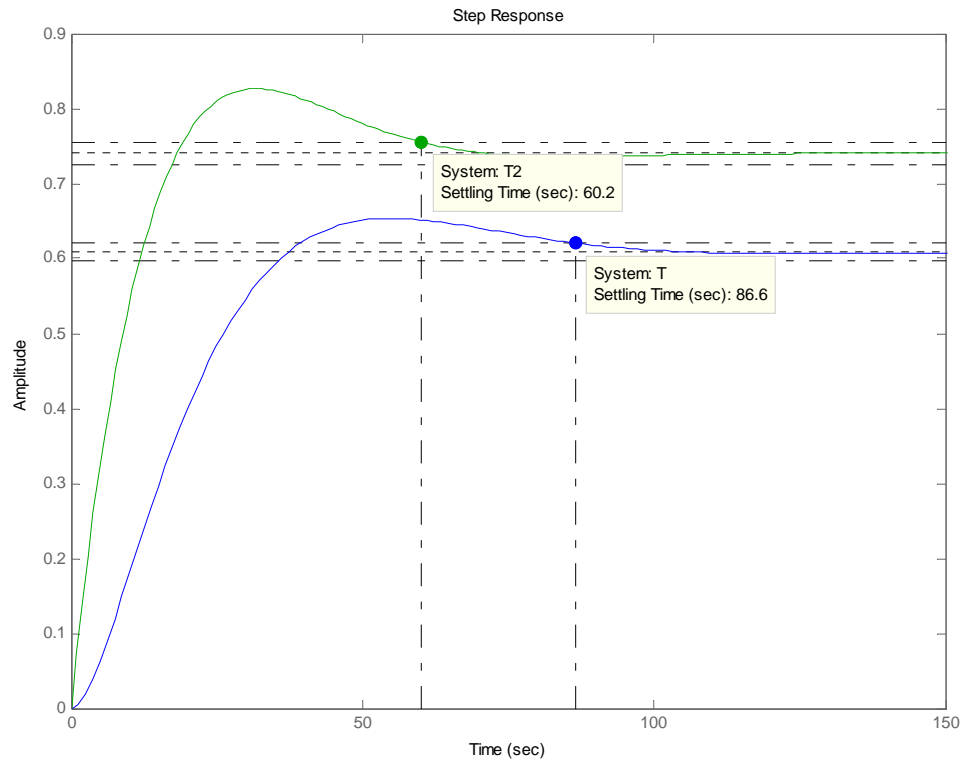

Note that the steady state error is also varied through ideal PD design because this is a type 0 system.

37.

a. This part is identical to the one in Problem 36.

b. As is problem III.b the desired closed loop pole positions are:  $-0.055 \pm j0.0562$ . The lead compensator has the form  $G_c(s) = \frac{K(s + z_c)}{(s + p_c)}$ . We arbitrarily choose  $z_c = -0.15$ , and perform a numerical search until the  $180^\circ$  angle condition is satisfied on the open loop transmission giving  $p_c = -0.3955$ . Then the gain is adjusted in sisotool until the poles are placed at their desired positions. The resulting compensator is:  $G_c(s) = \frac{6.6196(s + 0.15)}{(s + 0.3955)}$ . The resulting root locus is:

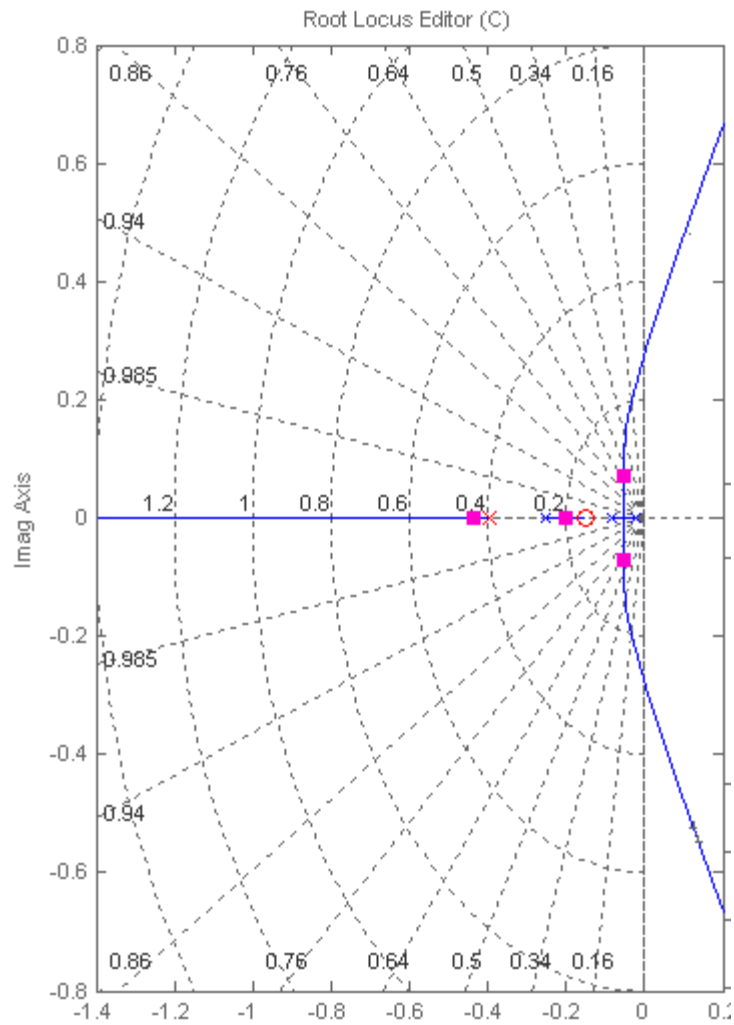

**c.**

```
>> syms s
```

```
>> s=tf('s');
```

```
>> Gv=0.02/(4*s+1);
```

```
>> G1=70/(50*s+1);
```

```
>> H=1/(12*s+1);
```

```
>> G=Gv*G1;
```

```
>> T=1.11*G/(1+1.11*G*H);
```

```
>> C=6.62*(s+0.15)/(s+0.396);
```

```
>> T2=C*G/(1+C*G*H);
```

```
>> step(T,T2)
```

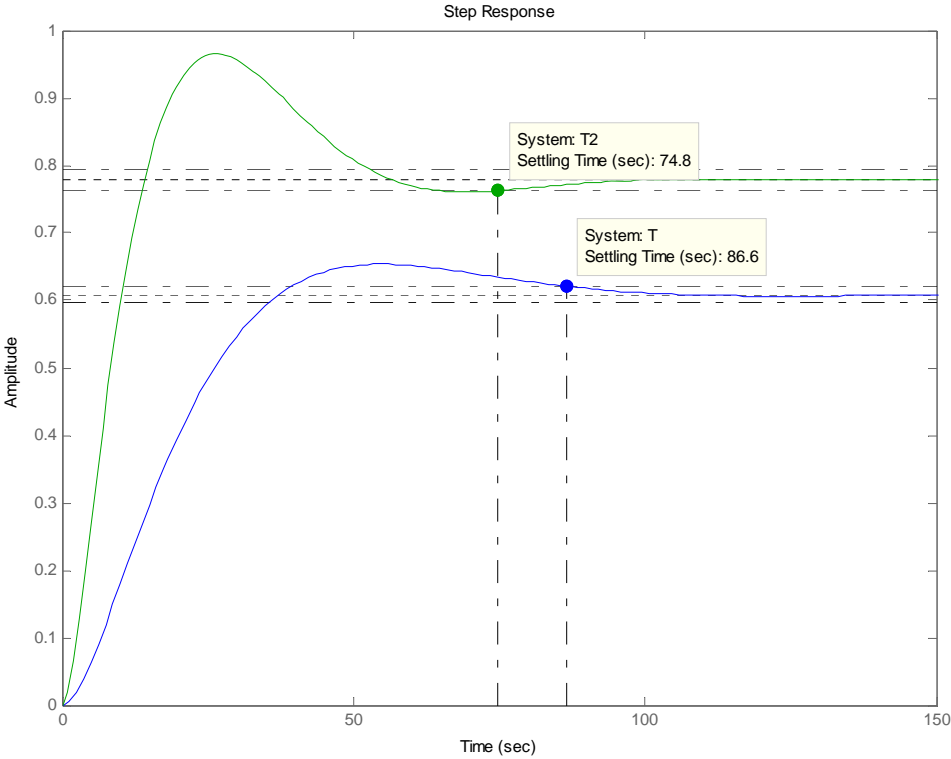

38.

$$\text{a. } \frac{\theta_m(s)}{E_a(s)} = \frac{\frac{K_t}{R_a J}}{s(s + \frac{1}{J}(D + \frac{K_t K_b}{R_a}))}$$

$$K_b = \frac{E_a}{\omega} = \frac{5}{\frac{60000}{2\pi} \times \frac{1}{60} \times 2\pi} = 0.005; J_{eq} = 5 \left(\frac{4}{10} \times \frac{1}{4}\right)^2 = 0.05; D_{eq} = 1 \left(\frac{1}{10}\right)^2 = 0.01;$$

$$\frac{K_t}{R_a} = \frac{T_s}{E_a} = \frac{0.5}{5} = 0.1. \text{ Therefore, } \frac{\theta_m(s)}{E_a(s)} = \frac{2}{s(s+0.21)}.$$

b. The block diagram of the system is shown below.

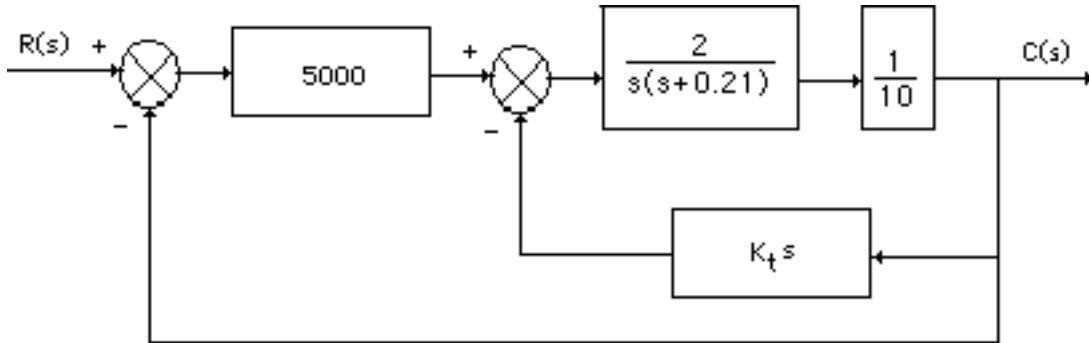

Forming an equivalent unity feedback system,

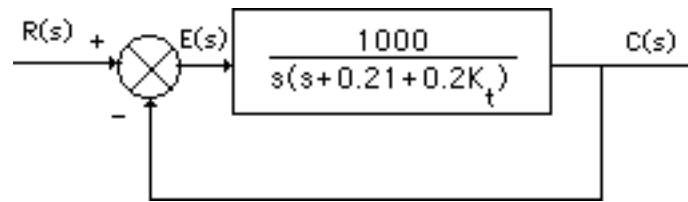

Now,  $T(s) = \frac{1000}{s^2 + (0.21 + 0.2K_t)s + 1000}$ . Thus,  $\omega_n = \sqrt{1000}$ ;  $2\zeta\omega_n = 0.21 + 0.2K_t$ . Since  $\zeta = 0.5$ ,  $K_t = 157.06$ .

c. **Uncompensated:**  $K_t = 0$ ;  $T(s) = \frac{1000}{s^2 + 0.21s + 1000}$ ;  $\omega_n = 31.62 \text{ rad/s}$ ;  $\zeta = 3.32 \times 10^{-3}$ ;

$$\%OS = e^{-\zeta\pi/\sqrt{1-\zeta^2}} \times 100 = 98.96\%; T_s = \frac{4}{\zeta\omega_n} = 38.09 \text{ seconds};$$

$$T_p = \frac{\pi}{\omega_n \sqrt{1-\zeta^2}} = 9.93 \times 10^{-2} \text{ second}; K_v = \frac{1000}{0.21} = 4761.9.$$

**Compensated:**  $K_t = 157.06$ ;  $T(s) = \frac{1000}{s^2 + 31.62s + 1000}$  ;  $\omega_n = 31.62 \text{ rad/s}$ ;  $\zeta = 0.5$ ;

$$\%OS = e^{-\zeta\pi/\sqrt{1-\zeta^2}} \times 100 = 16.3\%; T_s = \frac{4}{\zeta\omega_n} = 0.253 \text{ second}; T_p = \frac{\pi}{\omega_n \sqrt{1-\zeta^2}} = 0.115 \text{ second};$$

$$K_v = \frac{1000}{31.62} = 31.63.$$

39.

a.  $T(s) = \frac{25}{s^2 + s + 25}$  ; Therefore,  $\omega_n = 5$ ;  $2\zeta\omega_n = 1$ ;  $\zeta = 0.1$ ;

$$\%OS = e^{-\zeta\pi/\sqrt{1-\zeta^2}} \times 100 = 73\%; T_s = \frac{4}{\zeta\omega_n} = 8 \text{ seconds.}$$

b. From Figure P9.6(b),  $T(s) = \frac{25K_1}{s^2 + (1 + 25K_f)s + 25K_1}$  . Thus,

$$\omega_n = \sqrt{25K_1} ; 2\zeta\omega_n = 1 + 25K_f. \text{ For 25\% overshoot, } \zeta = 0.404. \text{ For } T_s = 0.2 = \frac{4}{\zeta\omega_n}, \zeta\omega_n = 20.$$

$$\text{Therefore } 1 + 25K_f = 2\zeta\omega_n = 40, \text{ or } K_f = 1.56. \text{ Also, } \omega_n = \frac{20}{\zeta} = 49.5.$$

$$\text{Hence } K_1 = \frac{\omega_n^2}{25} = \frac{49.5^2}{25} = 98.01.$$

c. **Uncompensated:**  $G(s) = \frac{25}{s(s+1)}$  ; Therefore,  $K_v = 25$ , and  $e(\infty) = \frac{1}{K_v} = 0.04$ .

**Compensated:**  $G(s) = \frac{25K_1}{s(s+1+25K_f)}$  ; Therefore,  $K_v = \frac{25 \times 98.01}{1+25 \times 1.56} = 61.26$ , and

$$e(\infty) = \frac{1}{K_v} = 0.0163.$$

40.

a. The transfer functions of the subsystems are as follows:

$$\text{Pot: } G_p(s) = \frac{5\pi}{10\pi} = \frac{1}{2} ; \text{ Amplifier: } G_a(s) = \frac{K_1}{s+20} ; \text{ Motor and load: Since the time to rise to 63\% of the}$$

final value is 0.5 second, the pole is at -2. Thus, the motor transfer function is of the form,  $G_m(s) =$

$$\frac{K}{s(s+2)} . \text{ But, from the problem statement, } \frac{K}{2} = \frac{100}{10} , \text{ or } K = 20. \text{ The block diagram of the system is}$$

shown below.

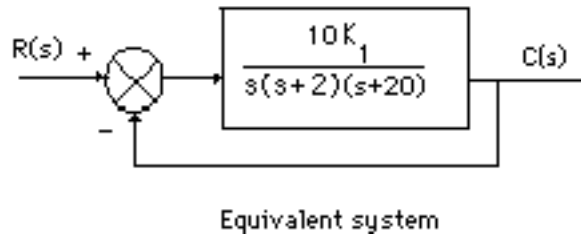
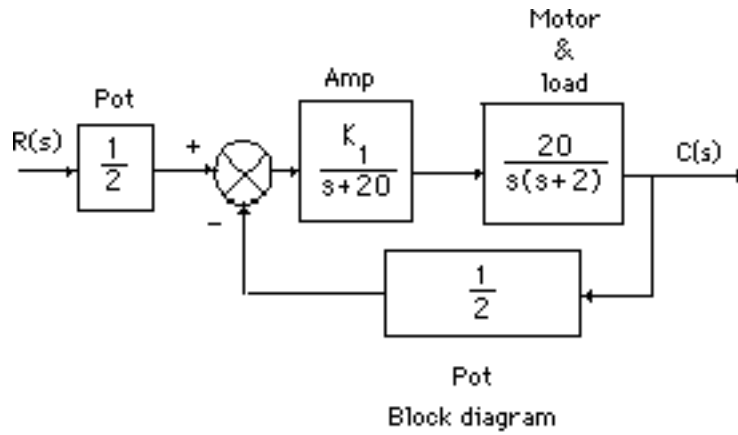

Using the equivalent system, search along the  $117.126^\circ$  line (20% overshoot) and find the dominant second-order pole at  $-0.89 + j1.74$  with  $K = 10K_1 = 77.4$ . Hence,  $K_1 = 7.74$ .

b.  $K_v = \frac{77.4}{2 \times 20} = 1.935$ . Therefore,  $e(\infty) = \frac{1}{K_v} = 0.517$ .

c.  $\%OS = 20\%$ ;  $\zeta = \frac{-\ln\left(\frac{\%OS}{100}\right)}{\sqrt{\pi^2 + \ln^2\left(\frac{\%OS}{100}\right)}} = 0.456$ ;  $\omega_n = \sqrt{0.89^2 + 1.74^2} = 1.95 \text{ rad/s}$ ;

$T_s = \frac{4}{\zeta\omega_n} = 4.49 \text{ seconds}$ ;  $T_p = \frac{\pi}{\omega_n\sqrt{1-\zeta^2}} = 1.81 \text{ seconds}$ .

d. The block diagram of the minor loop is shown below.

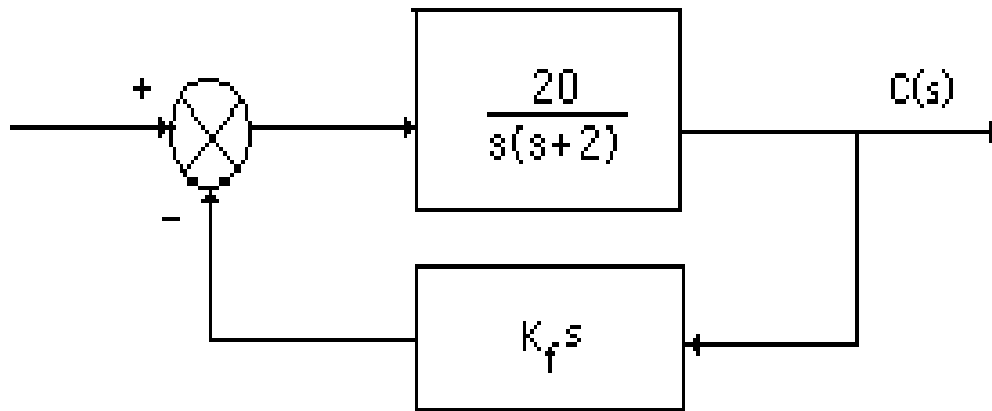



The transfer function of the minor loop is  $G_{ML}(s) = \frac{20}{s(s+2+20K_f)}$ . Hence, the block diagram of the equivalent system is

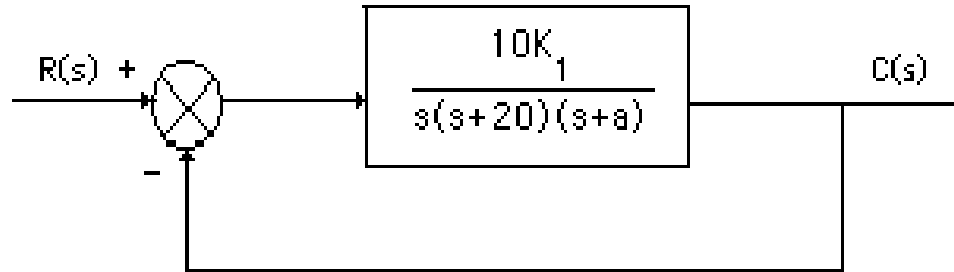

where  $a = 2 + 20K_f$ . The design point is now found. Since  $\%OS = 20\%$ ,  $\zeta = \frac{-\ln(\frac{\%OS}{100})}{\sqrt{\pi^2 + \ln^2(\frac{\%OS}{100})}} =$

0.456. Also, since  $T_s = \frac{4}{\zeta\omega_n} = 2$  seconds,  $\omega_n = 4.386$  rad/s. Hence, the design point is  $-2 + j3.9$ . Using

just the open-loop poles at the origin and at  $-20$ , the summation of angles to the design point is  $-129.37^\circ$ .

The pole at  $-a$  must then be contributing  $129.37^\circ - 180^\circ = -50.63^\circ$ . Using the geometry below,  $a = 5.2$ , or  $K_f = 0.16$ .

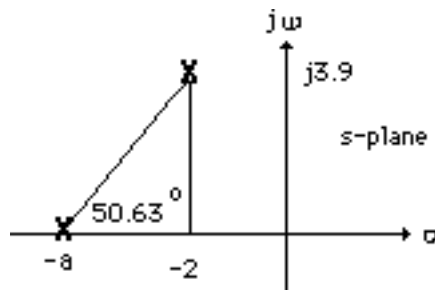

Adding the pole at  $-5.2$  and using the design point, we find  $10K_1 = 407.23$ , or  $K_1 = 40.723$ .

Summarizing the compensated transient characteristics:  $\zeta = 0.456$ ;  $\omega_n = 4.386$ ;  $\%OS = 20\%$ ;  $T_s = \frac{4}{\zeta\omega_n} =$

2 seconds;  $T_p = \frac{\pi}{\omega_n\sqrt{1-\zeta^2}} = 0.81$  seconds;  $K_v = \frac{407.23}{20 \times 5.2} = 3.92$ .

41.

Block diagram

**Preamplifier/Power amplifier:**  $\frac{K_1}{(s+40)}$ ; **Pots:**  $\frac{20\pi \text{ volts}}{5(2\pi) \text{ rad.}} = 2$ .

**Torque-speed curve:**

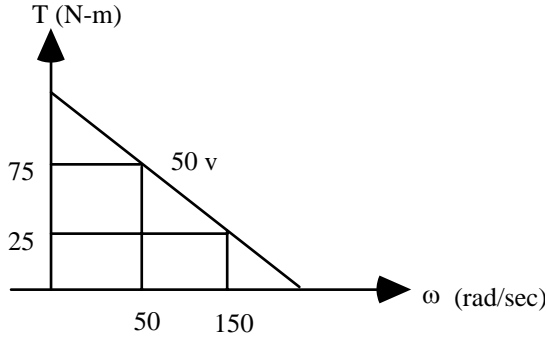

where  $1432.35 \frac{\text{rev}}{\text{min}} \times \frac{1 \text{ min}}{60 \text{ sec}} \times 2\pi \frac{\text{rad}}{\text{rev}} = 150 \text{ rad/sec}$ ;  $477.45 \frac{\text{rev}}{\text{min}} \times \frac{1 \text{ min}}{60 \text{ sec}} \times 2\pi \frac{\text{rad}}{\text{rev}} = 50 \text{ rad/sec}$ . The slope of the line is  $-\frac{50}{100} = -0.5$ . Thus, its equation is  $y = -0.5x + b$ . Substituting one of the points, find  $b$

$= 100$ . Thus  $T_{\text{stall}} = 100$ , and  $\omega_{\text{no load}} = 200$ .  $\frac{K_t}{R_a} = \frac{T_{\text{stall}}}{e_a} = \frac{100}{50} = 2$ ;  $K_b = \frac{e_a}{\omega_{\text{no load}}} = \frac{50}{200} = 0.25$ .

**Motor:**  $\frac{\theta_m(s)}{E_a(s)} = \frac{K_t/(R_a J)}{s(s + \frac{1}{J}(D + \frac{K_t K_b}{R_a}))} = \frac{0.02}{s(s + 0.505)}$ , where  $J = 100$ ,  $D = 50$ .

**Gears:** 0.1

Drawing block diagram:

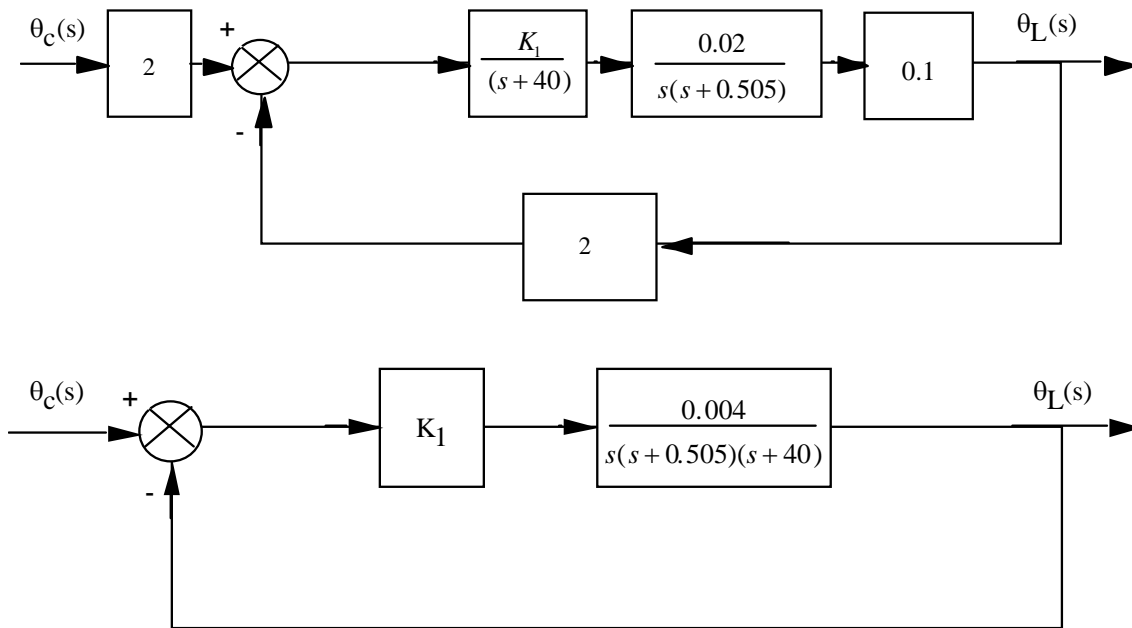

**b. Compensator design - Lead**

10% overshoot and  $T_s = 1$  sec yield a design point of  $-4 + j5.458$ . Sum of angles of uncompensated system poles to this point is  $-257.491^\circ$ . If we place the lead compensator zero over the uncompensated system pole at  $-0.505$ , the angle at the design point is  $-134.858^\circ$ . Thus, the lead compensator pole must contribute  $134.858^\circ - 180^\circ = -45.142^\circ$ . Using the geometry below

$$\frac{5.458}{p_c - 4} = \tan(45.142^\circ), \text{ or } p_c = 9.431.$$

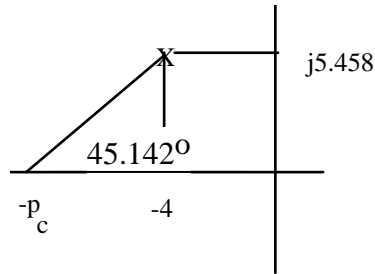

Using the uncompensated poles and the lead compensator, the gain at the design point is  $0.004K_1 = 1897.125$ .

#### Compensator design - Lag

With lead compensation,  $K_v = \frac{1897.125}{(40)(9.431)} = 5.0295.029$ . Since we want  $K_v = 1000$ ,  $\frac{z_{lag}}{p_{lag}} = \frac{1000}{5.029} =$

198.85. Use  $p_{lag} = 0.001$ . Hence  $z_{lag} = 0.1988$ . The lag compensated

$$G_e(s) = \frac{1897.125(s+0.1988)}{s(s+40)(s+9.431)(s+0.001)}.$$

#### c. Compensator schematic

lag:  $\frac{1}{R_2C} = 0.1988$ . Let  $C = 100 \mu\text{F}$ . Then  $R_2 = 50.3 \text{ k}\Omega$ . Now,  $\frac{1}{(R_1+R_2)C} = 0.001$ .

Thus,  $R_1 = 9.95 \text{ M}\Omega$ . Buffer gain = reciprocal of lag compensator's  $\frac{R_2}{R_1 + R_2}$ . Hence buffer

$$\text{gain} = \frac{R_1 + R_2}{R_2} = 198.8.$$

lead:  $\frac{1}{R_1C} = 0.505$ . Let  $C = 10 \mu\text{F}$ . Then  $R_1 = 198 \text{ k}\Omega$ . Now,  $\frac{1}{R_1C} + \frac{1}{R_2C} = 9.431$ .

Thus,  $R_2 = 11.2 \text{ k}\Omega$ .

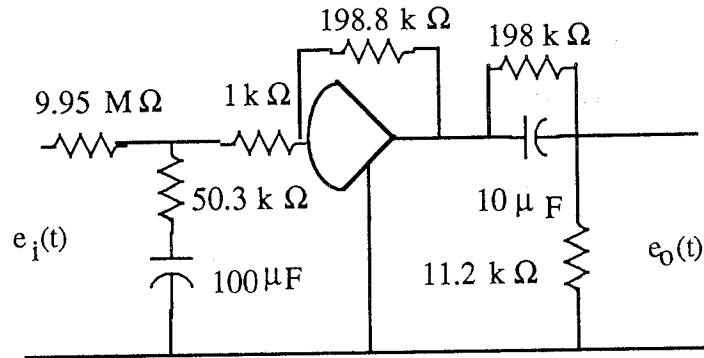

d.

**Program:**

```
numg= 1897.125*[1 0.1988];
deng=poly([0 -40 -9.431 -.001]);
'G(s)'
G=tf(numg,deng);
Gzpk=zpk(G)
rlocus(G)
pos=10
z=-log(pos/100)/sqrt(pi^2+[log(pos/100)]^2)
sgrid(z,0)
title(['Root Locus with ', num2str(pos), ' Percent Overshoot Line'])
[K,p]=rlocfind(G) %Allows input by selecting point on graphic
pause
T=feedback(K*G,1);
step(T)
title(['Step Response for Design of ', num2str(pos), ' Percent'])
```

**Computer response:**

ans =

G(s)

Zero/pole/gain:

1897.125 (s+0.1988)

-----  
s (s+40) (s+9.431) (s+0.001)

pos =

10

z =

0.5912

Select a point in the graphics window

selected\_point =

-3.3649 + 4.8447i

K =

0.9090

$p =$

-41.3037  
 -3.9602 + 4.9225i  
 -3.9602 - 4.9225i  
 -0.2080

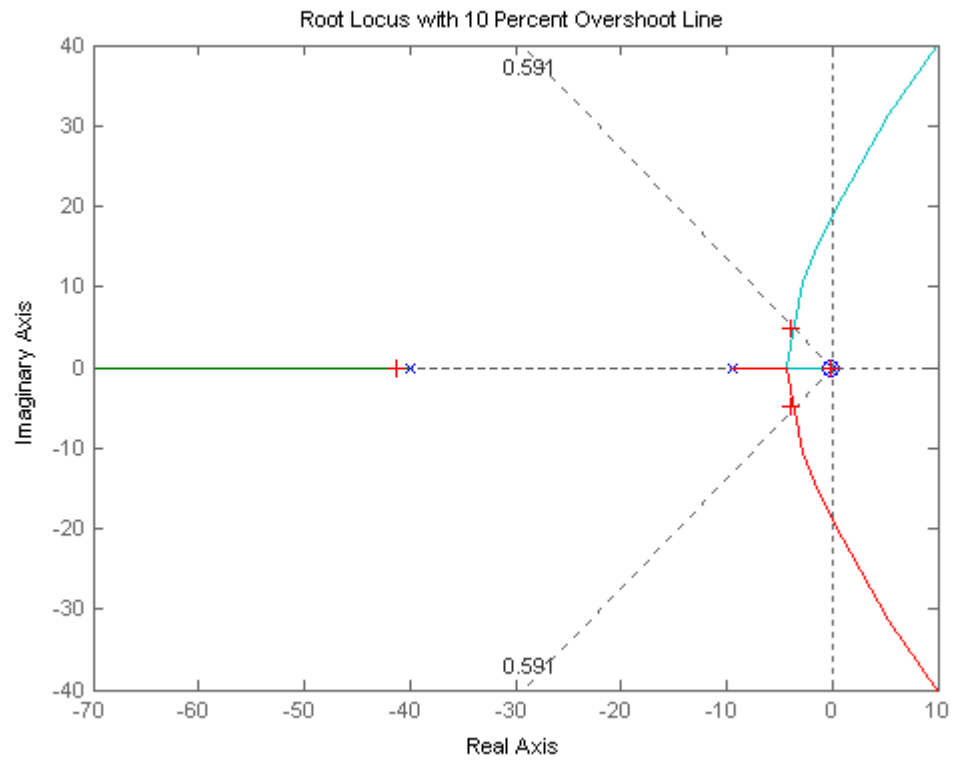

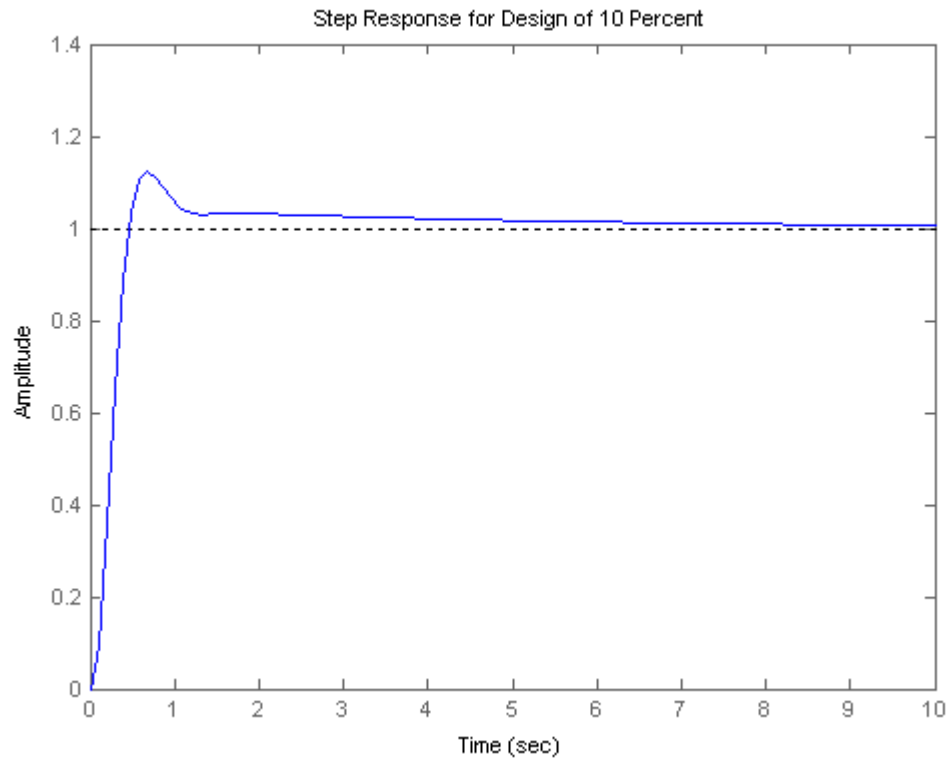

42.

Consider only the minor loop. Searching along the  $143.13^\circ$  line ( $\zeta = 0.8$ ), locate the minor-loop dominant poles at  $-3.36 \pm j2.52$  with  $K_f = 8.53$ . Searching the real axis segments for  $K_f = 8.53$  locates a higher-order pole at  $-0.28$ . Using the minor-loop poles as the open-loop poles for the entire system, search along the  $120^\circ$  line ( $\zeta = 0.5$ ) and find the dominant second-order poles at  $-1.39 + j2.41$  with  $K = 27.79$ . Searching the real axis segment locates a higher-order pole at  $-4.2$ .

43.

Consider only the minor loop. Searching along the  $143.13^\circ$  line ( $\zeta = 0.8$ ), locate the minor-loop dominant poles at  $-7.74 \pm j5.8$  with  $K_f = 36.71$ . Searching the real axis segments for  $K_f = 36.71$  locates a higher-order pole at  $-0.535$ . Using the minor-loop poles at  $-7.74 \pm j5.8$  and  $-0.535$  as the open-loop poles (the open-loop zero at the origin is not a closed-loop zero) for the entire system, search along the  $135^\circ$  line ( $\zeta = 0.707$ ; 4.32% overshoot) and find the dominant second-order poles at  $-4.38 + j4.38$  with  $K = 227.91$ . Searching the real axis segment locates a higher-order pole at  $-7.26$ . Uncompensated system performance: Setting  $K_f = 0$  and searching along the  $135^\circ$  line (4.32% overshoot) yields  $-2.39 + j2.39$  as the point on the root locus with  $K = 78.05$ . Searching the real axis segments of the root locus for  $K = 78.05$  locates a higher-order pole at  $-11.2$ . The following table compares the predicted uncompensated characteristics with the predicted compensated characteristics.

**Uncompensated**

$$G(s) = \frac{78.05}{(s+1)(s+5)(s+10)}$$

Dominant poles:  $-2.39 + j2.39$

$$\zeta = 0.707$$

$$\%OS = e^{-\zeta\pi/\sqrt{1-\zeta^2}} \times 100 = 4.32\%$$

$$\omega_n = \sqrt{2.39^2 + 2.39^2} = 3.38 \text{ rad/s}$$

$$T_s = \frac{4}{\zeta\omega_n} = 1.67 \text{ seconds}$$

$$T_p = \frac{\pi}{\omega_n\sqrt{1-\zeta^2}} = 1.31 \text{ seconds}$$

$$K_p = \frac{78.05}{1 \times 5 \times 10} = 1.56$$

Higher-order pole:  $-11.22$

Second-order approximation OK

axis than dominant poles.

**Compensated**

$$G(s) = \frac{227.91}{s^3 + 16s^2 + 101.71s + 50}$$

Dominant poles:  $-4.38 + j4.38$

$$\zeta = 0.707$$

$$\%OS = e^{-\zeta\pi/\sqrt{1-\zeta^2}} \times 100 = 4.32\%$$

$$\omega_n = \sqrt{4.38^2 + 4.38^2} = 6.19 \text{ rad/s}$$

$$T_s = \frac{4}{\zeta\omega_n} = 0.91 \text{ second}$$

$$T_p = \frac{\pi}{\omega_n\sqrt{1-\zeta^2}} = 0.72 \text{ second}$$

$$K_p = \frac{227.91}{50} = 4.56$$

Higher-order pole:  $-7.26$

Higher-order pole not 5x further from imaginary axis than dominant poles.

Simulate to be sure of the performance.

44.

In Problem 46, Chapter 8, the dominant poles,  $-40 \pm j57.25$ , yielded  $T_s = 0.1$  second and 11.14% overshoot. The unity feedback system consisted of a gain adjusted forward transfer function of

$G(s) = \frac{20000K}{s(s+100)(s+500)(s+800)}$ , where  $K = 102,300$ . To reduce the settling time by a factor of 2 to 0.05 seconds and keep the percent overshoot the same, we double the coordinates of the dominant poles to  $-80 \pm j114.5$ . Assume a lead compensator with a zero at  $-100$  that cancels the plant's pole at  $-100$ . The summation of angles of the remaining plant poles to the design point is  $149.23^\circ$ . Thus, the angular contribution of the compensator pole must be  $149.23^\circ - 180^\circ = 30.77^\circ$ . Using the geometry below,  $\frac{114.5}{p_c - 80} = \tan 30.77^\circ$ , or  $p_c = 272.3$ .

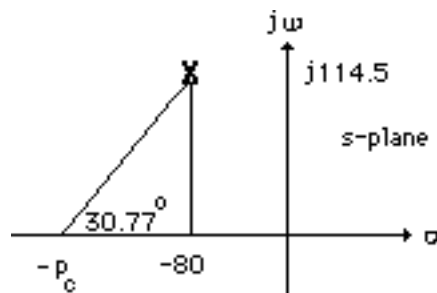

Adding this pole to the poles at the origin,  $-500$ , and  $-800$  yields  $K = 9.92 \times 10^9$  at the design point,  $-80 \pm j114.5$ . Any higher-order poles will have a real part greater than 5 times that of the dominant pair. Thus, the second-order approximation is OK.

45.

**Uncompensated:**  $G(s)H(s) = \frac{0.35K}{(s+0.4)(s+0.5)(s+0.163)(s+1.537)}$  . Searching the 133.639° line

(%OS = 5%), find the dominant poles at  $-0.187 \pm j0.196$  with gain,  $0.35K = 2.88 \times 10^{-2}$ . Hence, the

estimated values are: %OS = 5%;  $T_s = \frac{4}{\zeta\omega_n} = \frac{4}{0.187} = 21.39$  seconds;  $T_p = \frac{\pi}{\omega_n\sqrt{1-\zeta^2}} = \frac{\pi}{0.196} =$

16.03 seconds;  $K_p = 0.575$ .

**PD compensated:** Design for 8 seconds peak time and 5% overshoot.

$$\zeta = \frac{-\ln\left(\frac{\%OS}{100}\right)}{\sqrt{\pi^2 + \ln^2\left(\frac{\%OS}{100}\right)}} = 0.69. \text{ Since } T_p = \frac{\pi}{\omega_n\sqrt{1-\zeta^2}} = 8 \text{ seconds and } \omega_n\sqrt{1-\zeta^2} = 0.393,$$

$\omega_n = 0.5426$ . Hence,  $\zeta\omega_n = 0.374$ . Thus, the design point is  $-0.374 + j0.393$ . The summation of angles from the system's poles to the design point is  $-295.34^\circ$ . Thus, the angular contribution of the controller zero must be  $295.34^\circ - 180^\circ = 115.34^\circ$ . Using the geometry below,

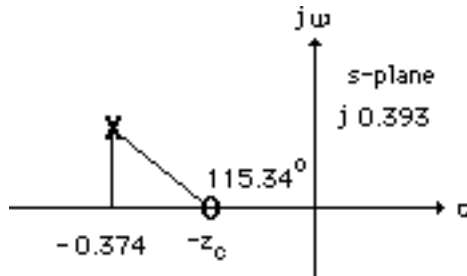

$\frac{0.393}{0.374 - z_c} = \tan(180^\circ - 115.34^\circ)$ , from which  $z_c = 0.19$ . Adding this zero to the system's poles and using the design point,  $-0.374 + j0.393$ , the gain,  $0.35K = 0.205$ .

**PID compensated:** Assume the integral controller,  $G_c(s) = \frac{s+0.01}{s}$  . The total open-loop transfer

$$\text{function is } G_{PID}(s)H(s) = \frac{0.35K(s+0.19)(s+0.01)}{s(s+0.4)(s+0.5)(s+0.163)(s+1.537)} .$$

Check: The PID compensated system yields a very slow rise time due to the lag zero at 0.01. The rise time can be sped up by moving the zero further from the imaginary axis with resultant changes in the transient response. The plots below show the step response with the PI zero at  $-0.24$ .



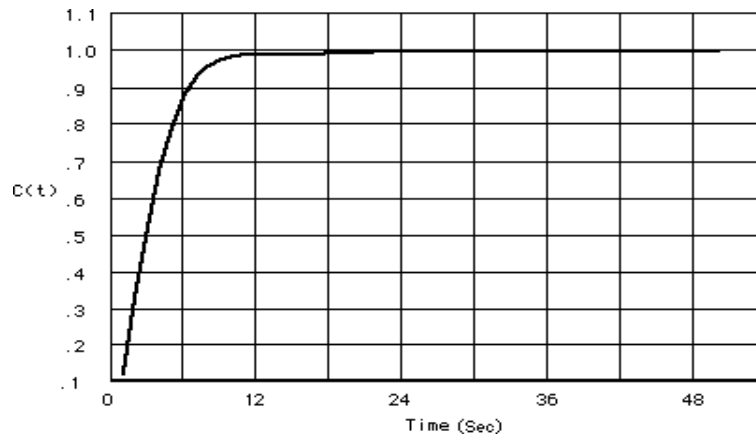

The response compares favorably with a two-pole system step response that yields 5% overshoot and a peak time of 8 seconds as shown below.

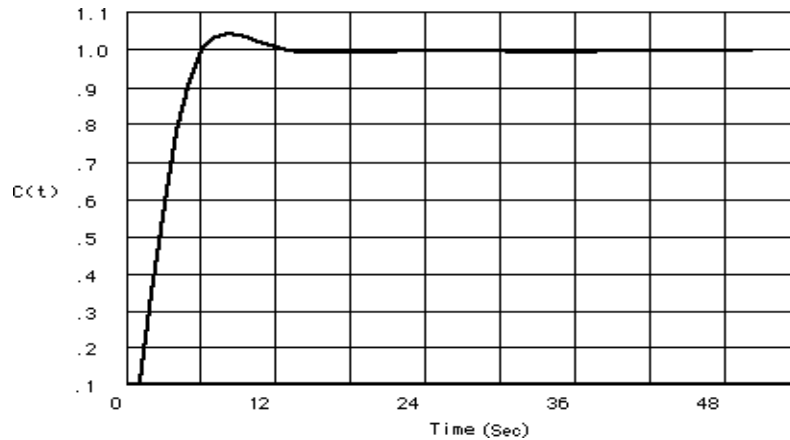

46.

- a. The open loop transfer function is  $G(s) = \frac{1}{(s + 0.08)(s + 2)(s + 5)}$ . The root locus for the system is shown below. With  $G_c(s) = 7.02$  the system has a  $\xi = 0.7$  damping factor for the dominant poles which are located at  $-0.847 \pm j0.849$ . The third pole is located at  $-5.4$  so the 2<sup>nd</sup> order approximation applies. The resulting  $T_s = 5.16s$  with a %OS=4.2%

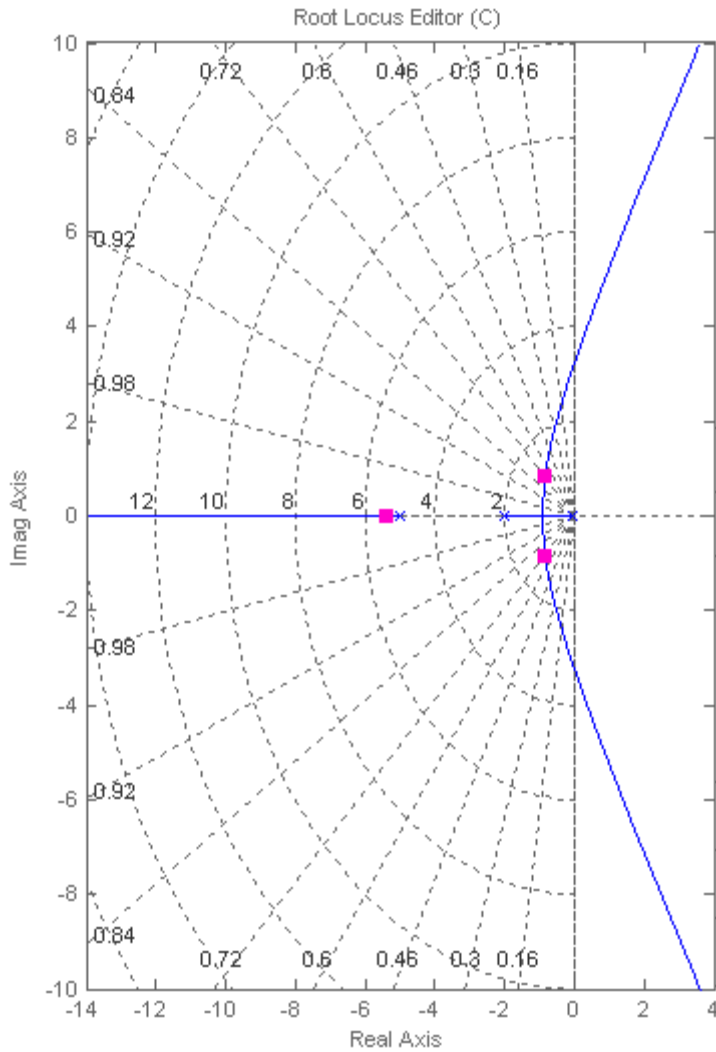

- b. The desired  $T_s = \frac{4}{\xi\omega_n} = 2$  sec, so the real part of the desired closed loop poles is  $\xi\omega_n = 2$ . The imaginary part is obtained from  $\omega_d = 2 \tan \cos^{-1} 0.7 = 2.04$ . So the desired dominant closed loop positions are  $-2 \pm j2.04$ . We start by doing PD design with a compensator of the form  $G_C(s) = K(s + z_c)$ . A numerical search results in  $z_c = 2.456$ , and  $K = 9.963$  gives the desired pole positions. So  $G_C(s) = 9.963(s + 2.456)$ . The root locus is shown next where it can be seen that the third pole is at approximately -3.06, so the dominant pole approximation is not as accurate as in part a)

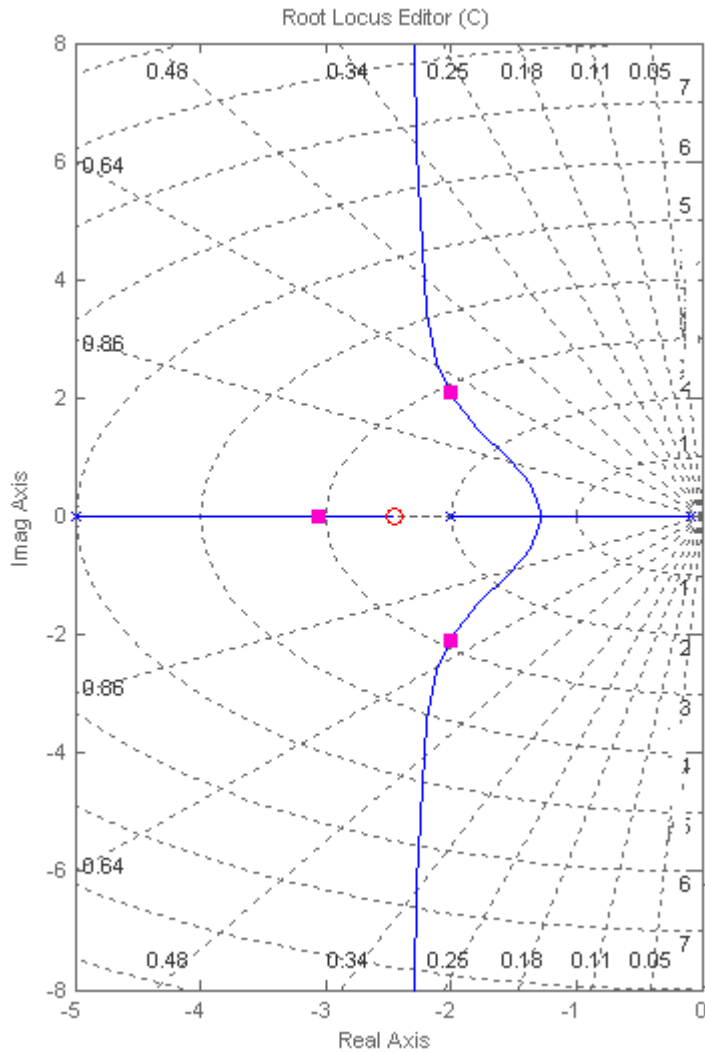

For the PI part we arbitrarily choose a zero close to the origin. After adjusting the gain to obtain the desired damping factor, the resulting PID compensator is  $G_c(s) = \frac{9.717(s + 0.1)(s + 2.456)}{s}$ , the

third pole moving to -3.16.

**c.**

```
>>syms s
```

```
>>s=tf('s');
```

```
>>Gc=9.717*(s+0.1)*(s+2.456)/s;
```

```
>>G=1/(s+0.08)/(s+2)/(s+5);
```

```
>>T=6.95*G/(1+6.95*G); % No compensation
```

```
>>T2=Gc*G/(1+Gc*G); % PID Compensation
```

```
>> step(T,T2,6) % Simulate up to 6 sec
```

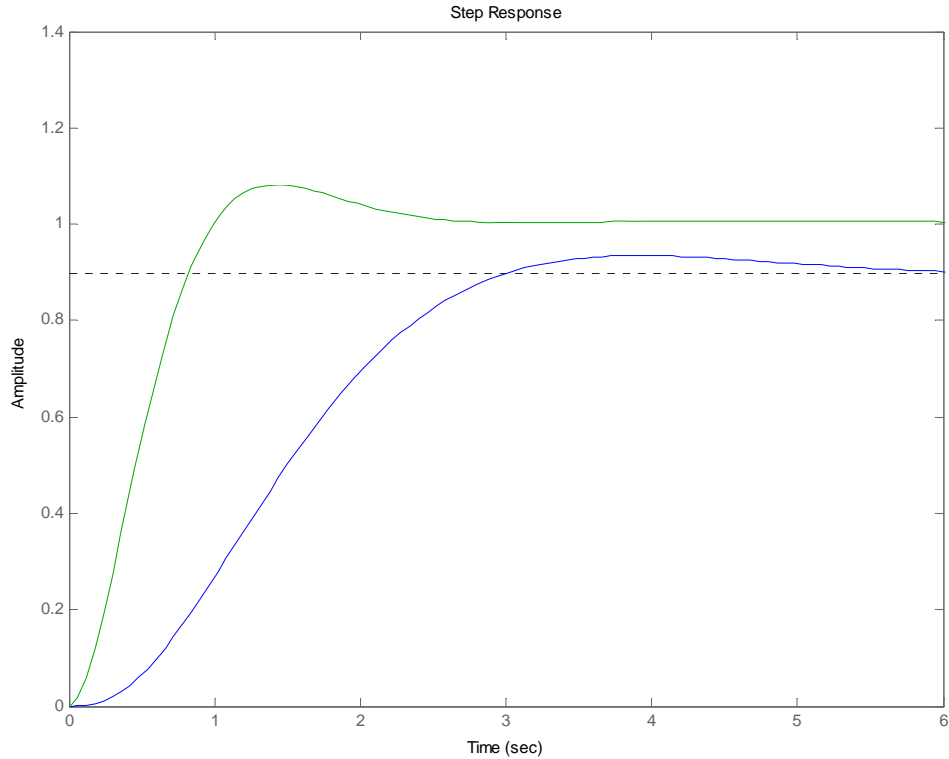

Note that the compensated response results in the desired Settling time, however the resulting %OS $\approx$ 8% is larger than expected due to the third pole being close to the dominant poles.

47.

a. This part is identical to 46a)

b. We start by designing the lead compensator. The desired closed loop pole positions are

$-2 \pm j2.04$  as in problem IV. We arbitrarily choose the position of the compensator zero at -2

(cancelling a plant pole), and do a numerical search to get the pole position as -11.8, then adjust the gain

until the desired pole positions are obtained. At this stage we have  $G_c(s) = \frac{95.7(s+2)}{(s+11.2)}$ . The

resulting roots locus is:

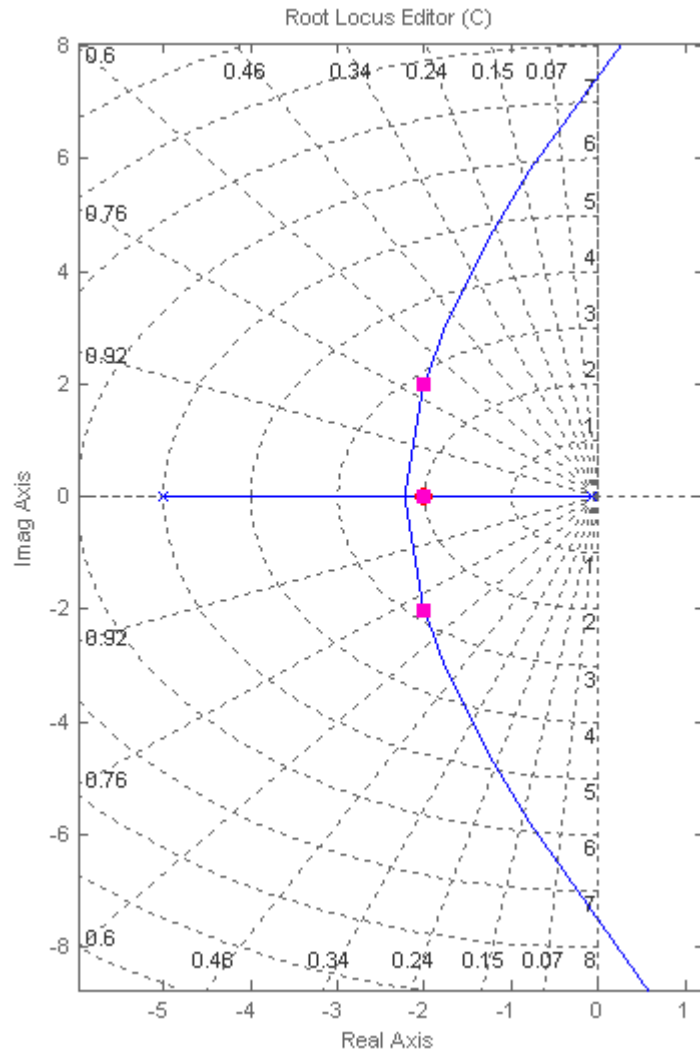

Now we do the lag compensator design by first choosing arbitrarily the lag compensators pole position as  $-0.01$  so the systems open loop transmission is:

$$G(s) = \frac{95.7(s + z_{lag})}{(s + 0.01)(s + 0.08)(s + 5)(s + 11.2)} . \text{ The steady state requirements demand}$$

$$G(0) = 99 , \text{ so } z_{lag} = 0.0463 . \text{ The lead lag compensator is: } G_c(s) = \frac{95.7(s + 0.0463)(s + 2)}{(s + 0.01)(s + 11.2)} .$$

The roots locus is:

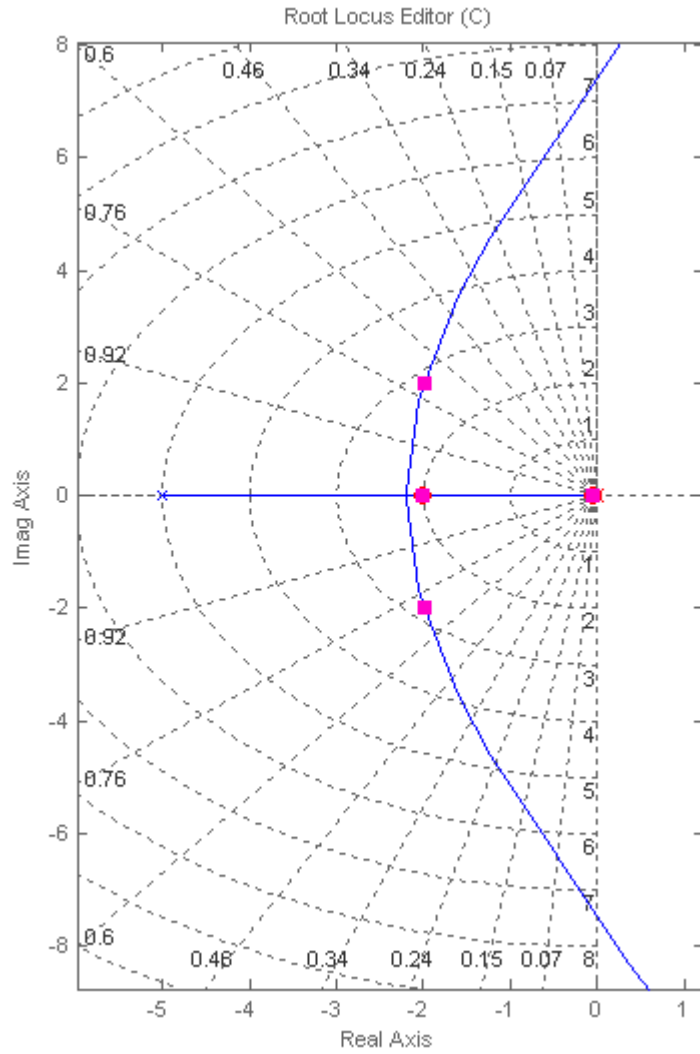

48.

a.

The root locus for the uncompensated system is shown next. The range for closed loop stability is  $0 < K < 0.04$ . The fastest system will occur for very small values of  $K$  with  $T_s \approx 0.8$  sec. The dominant poles have a damping factor  $0 < \xi < 0.02$

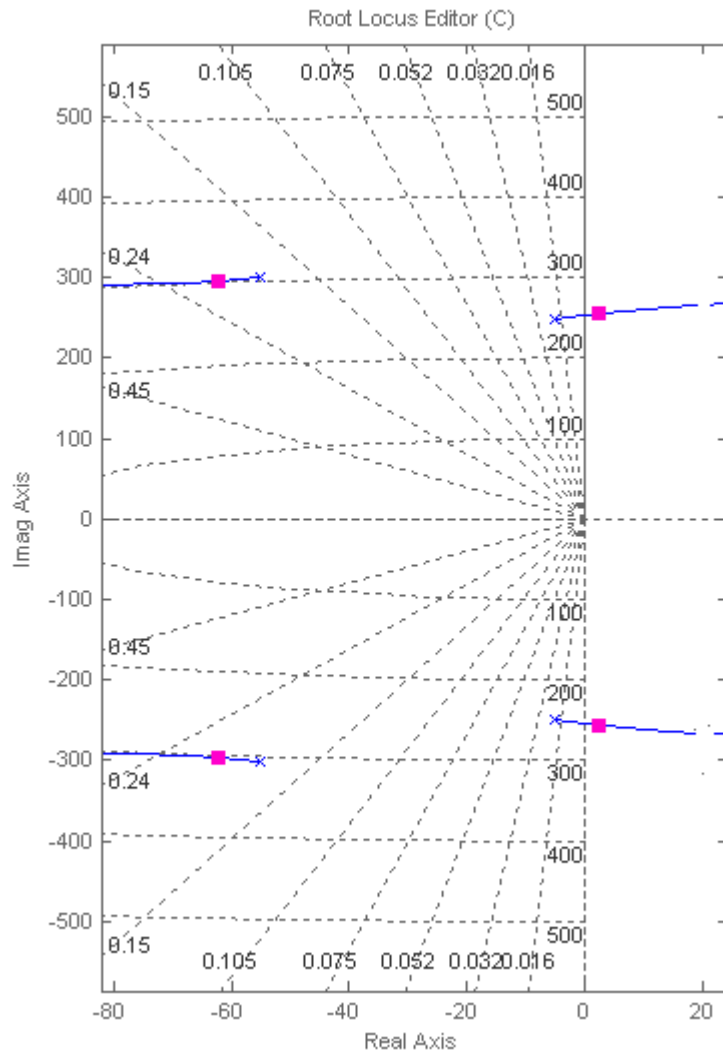

b. The notch filter is designed by arbitrarily placing two complex conjugate zeros close to the dominant complex pole plant pair, and then arbitrarily adding two 'far away' real poles in between the two pairs of plant poles. The gain is adjusted to obtain  $\xi = 0.7$ . The resulting

$$G_c(s) = \frac{0.0679(s^2 + 12s + 6.25e4)}{(s + 20)(s + 70)}$$

The resulting root locus is:

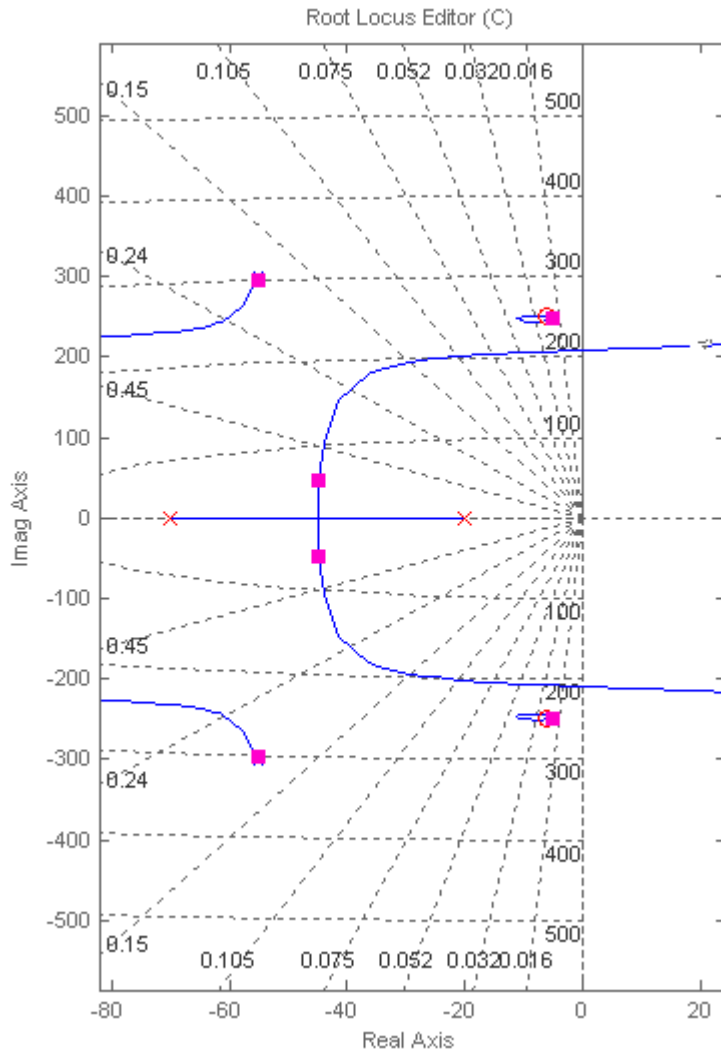

The time domain simulation results in: %OS=5.22%,  $T_s = 0.093$ sec

```
>> syms s
>> s=tf('s');
>> P=0.63/(1+2*0.18*s/305.4+s^2/305.4^2)/(1+2*0.02*s/248.2+s^2/248.2^2);
>> G=0.0679*(s^2+12*s+6.25e4)/(s+20)/(s+70);
>> T=G*P/(1+G*P);
>> step(T)
```



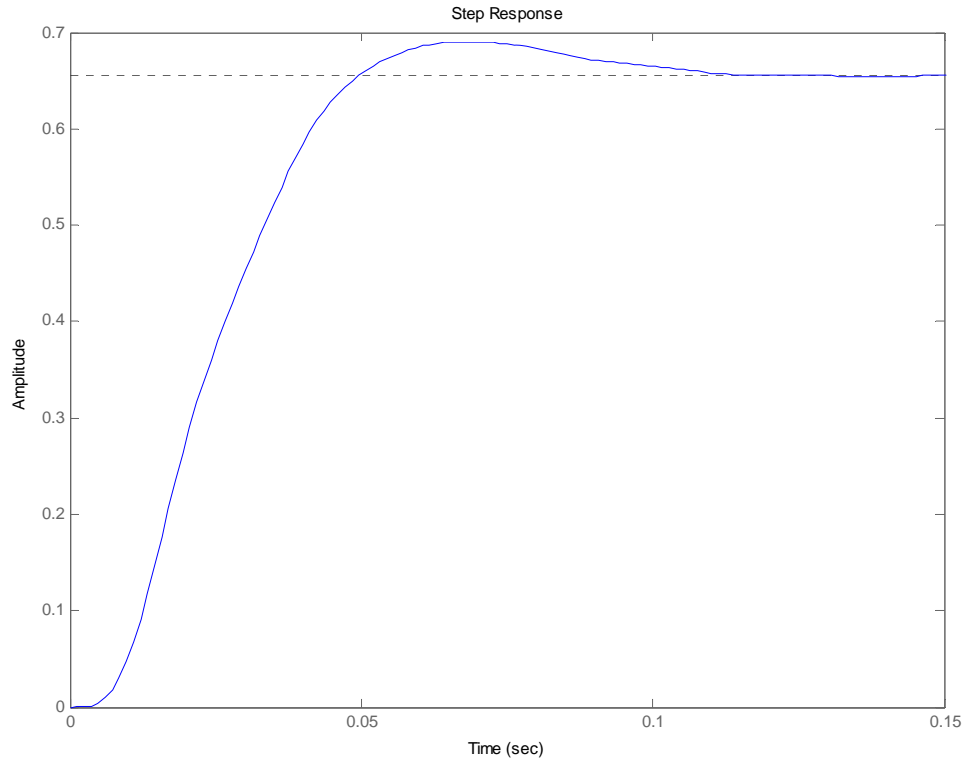

c. The PI compensator is designed by adding a pole at the origin and arbitrarily placing a zero at the same point as that of the rightmost compensator pole. The resulting

$$G_c(s) = \frac{0.0586(s^2 + 12s + 6.25e4)}{s(s + 70)}$$

where the gain was adjusted to maintain the damping factor.

The resulting simulation gives %OS=4.3% and  $T_s = 0.124$ sec

```
>> syms s
```

```
>> s=tf('s');
```

```
>> P=0.63/(1+2*0.18*s/305.4+s^2/305.4^2)/(1+2*0.02*s/248.2+s^2/248.2^2);
```

```
>> G=0.0586*(s^2+12*s+6.25e4)/s/(s+70);
```

```
>> T=G*P/(1+G*P);
```

```
>> step(T,0.15)
```

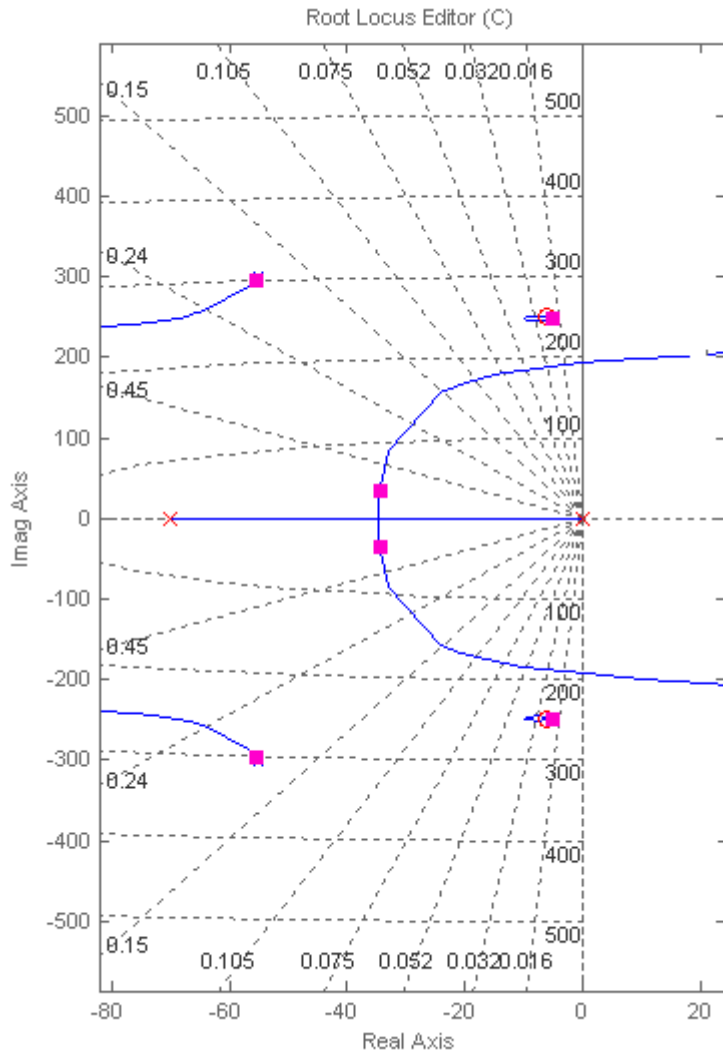

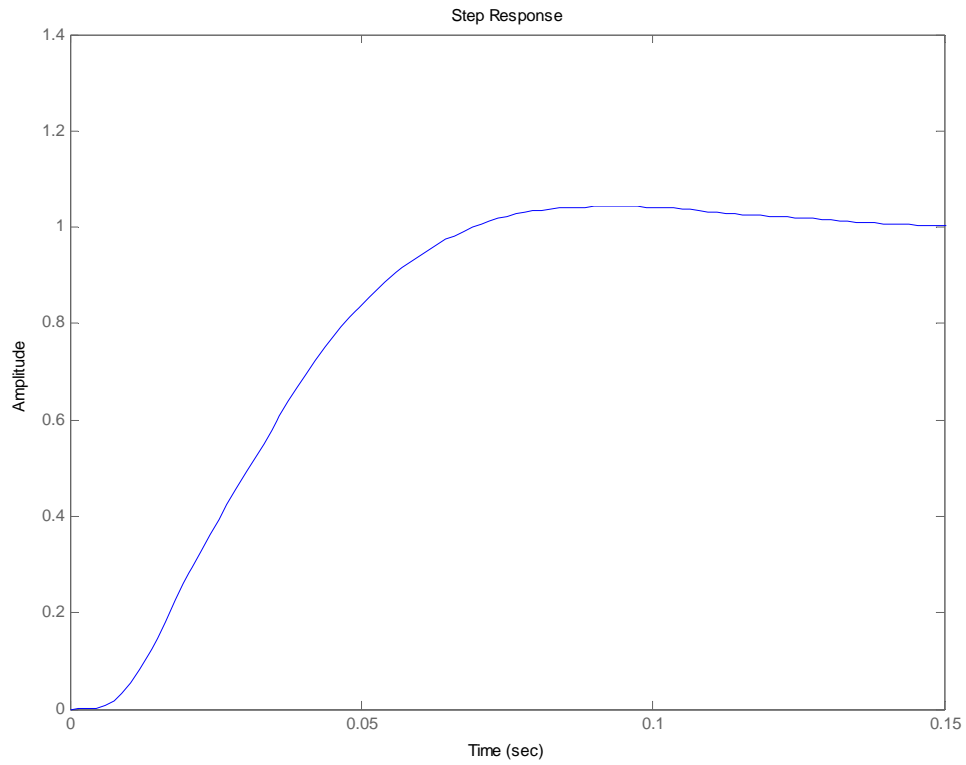

**49.**

a. The open loop transmission for the minor loop is  $L_{ML} = \frac{26.45(s^2 + 1.15s + 0.33)}{s^2 + 1.4.24s + 3447.91}$ . The root

locus is shown next where  $K=132$  results in the desired  $\xi = 0,5$

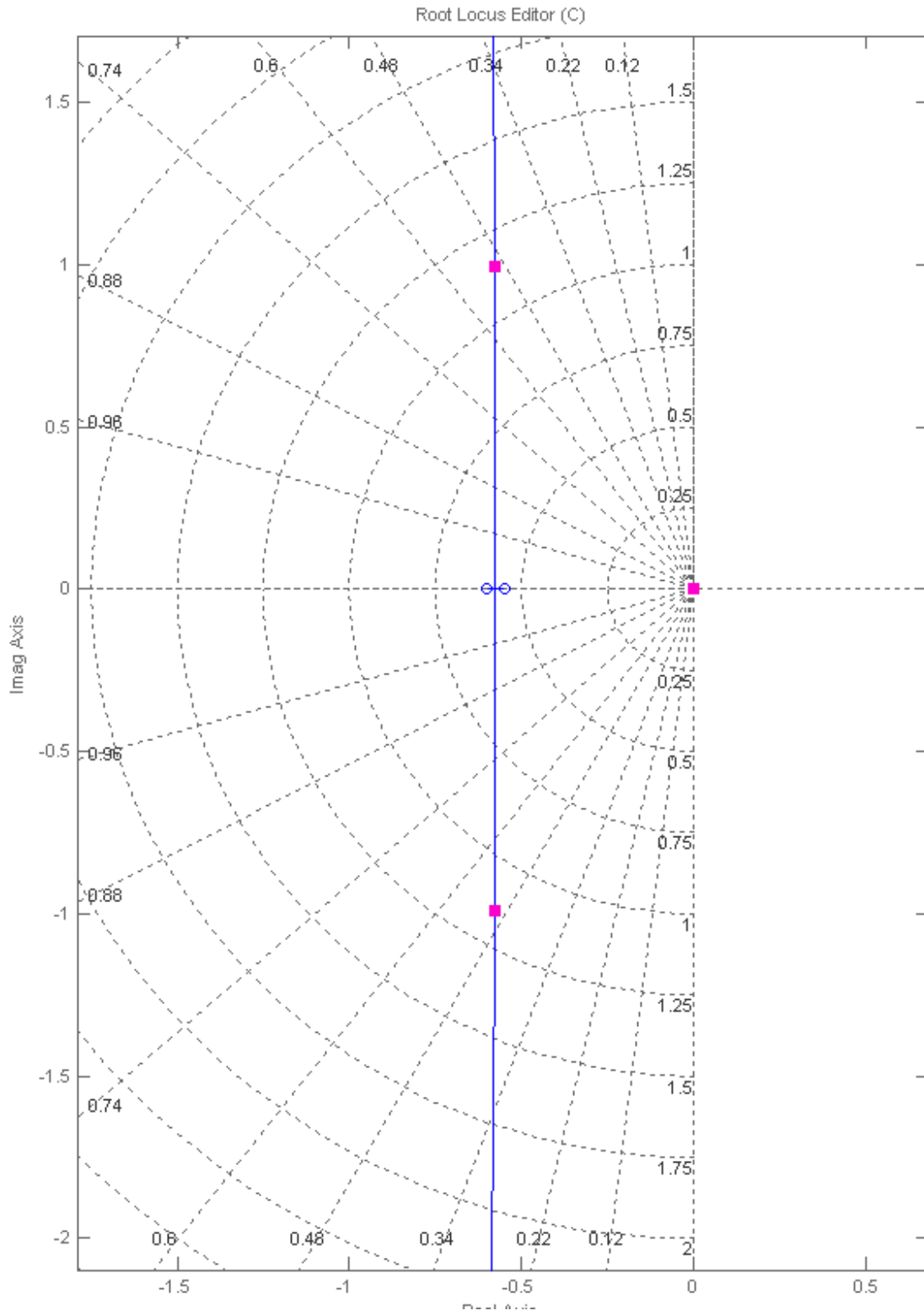

**b.**

With the value of K calculated in part a, the overall open loop transfer function from the main loop point

view is 
$$G = \frac{7.59e004s^3 + 1.081e006s^2 + 2.617e008s}{3492s^6 + 5.376e004s^5 + 1.21e007s^4 + 1.396e007s^3 + 1.586e007s^2}$$

which results in an origin pole zero cancellation and an integrator at the origin. The uncompensated root locus is shown next:

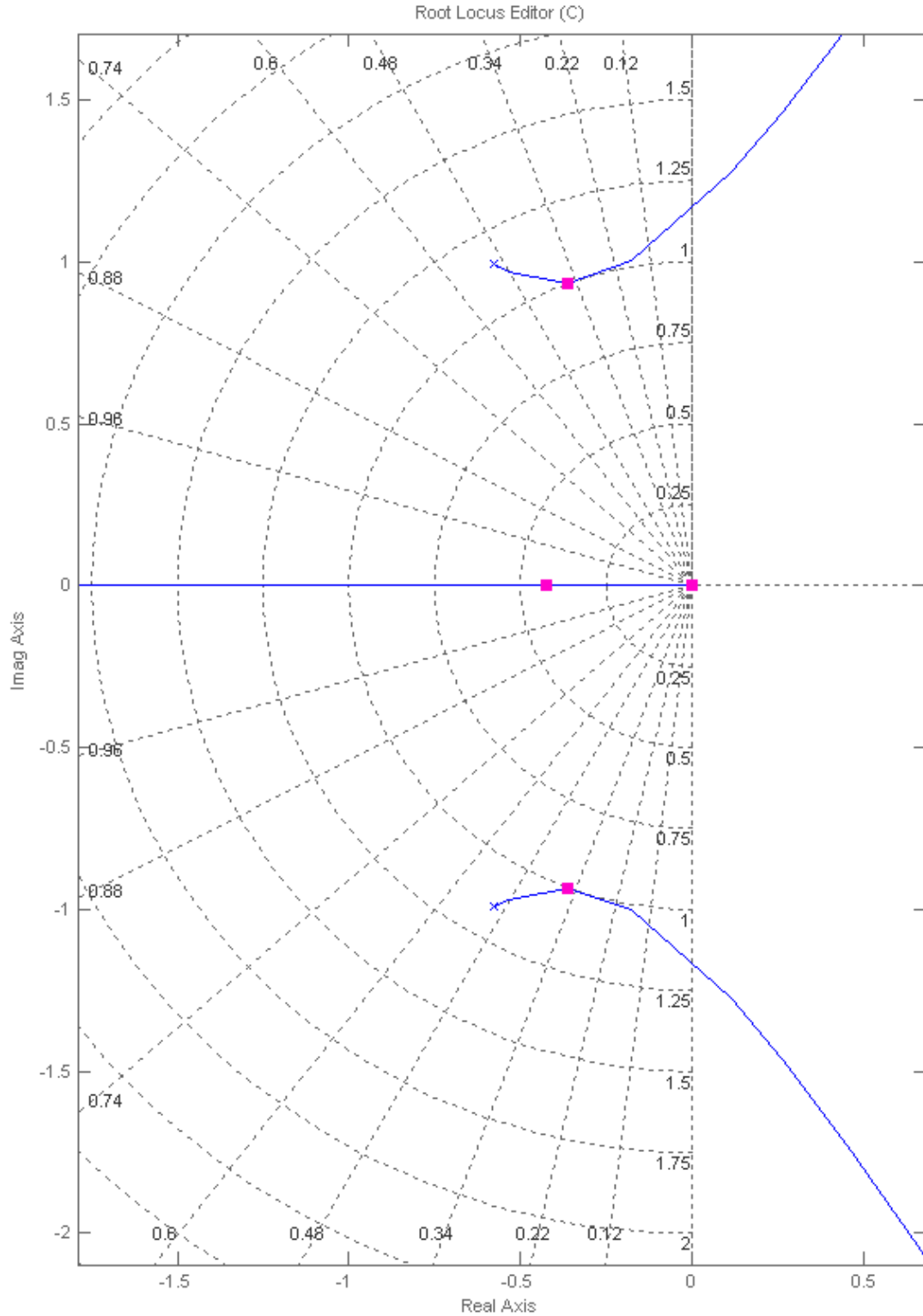

With the two complex conjugate poles it is necessary to use a notch filter to obtain the required  $\xi = 0.7$ . For  $G_c(s)$  design the compensator zeros are chosen close to the open loop poles and the

poles are placed arbitrarily on the real axis, then the gain is adjusted to get the required damping factor.

To satisfy the settling time requirement, the real poles are adjusted interactively in sisotool until their real part is  $\approx 1$ . The resulting compensator is:  $G_c(s) = \frac{0.738(s^2 + 1.15s + 1.34)}{(s + 3)(s + 5)}$ . The resulting

root locus is:

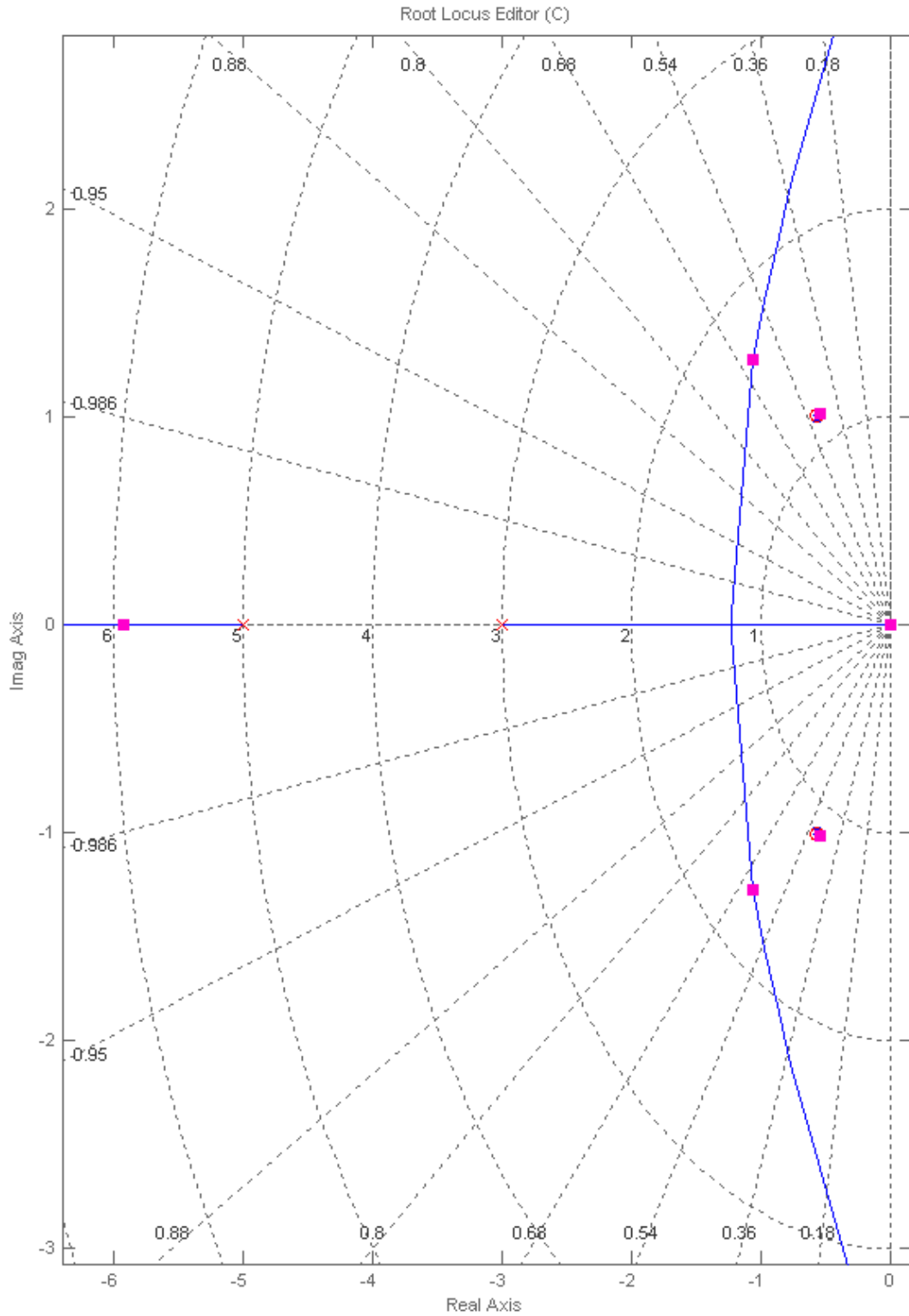



c.

```

>> syms s
>> s=tf('s');
>> G1=574.98/s/(s^2+14.24*s+3447.91);
>> H=0.046*s*(s^2+1.15*s+0.33);
>> Gml=132*G1/(1+132*G1*H);
>> Gc=0.738*(s^2+1.15*s+1.34)/(s+3)/(s+5);
>> T=Gc*Gml/(1+Gc*Gml);
>> step(T)

```

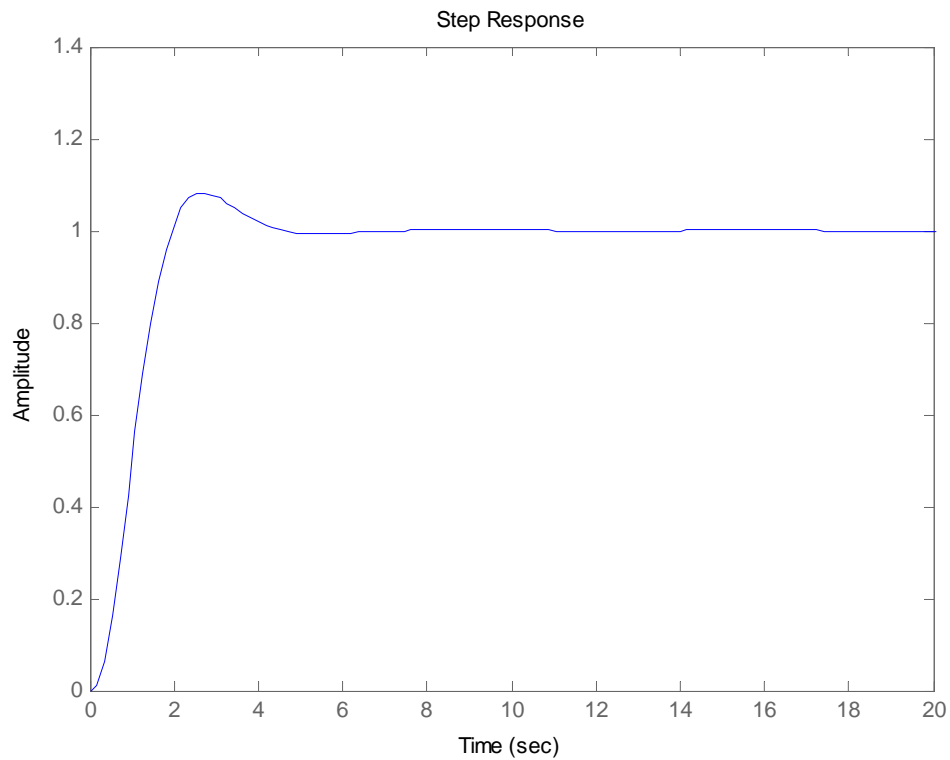

50.

**a. PD compensator design:** Pushing the gain, 10, to the right past the summing junction, the system can

be represented as an equivalent unity feedback system with  $G_e(s) = \frac{10^6}{(s^2 - 4551)(s + 286)}$ . This

system is unstable at any gain. For 1% overshoot and  $T_s = 0.1$ , the design point is  $-40 + j27.29$ . The summation of angles from the poles of  $G_e(s)$  to this point is  $-216.903^\circ$ . Therefore, the compensator zero must contribute  $216.903^\circ - 180^\circ = 36.903^\circ$ . Using the following geometry:

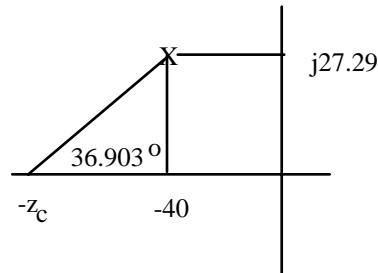

$\frac{27.29}{z_c - 40} = \tan(36.903)$ . Thus,  $z_c = 76.34$ . Adding this zero to the poles of  $G_e(s)$ , the gain at the design point is  $10^6 K = 23377$ . The PD compensated response is shown below.

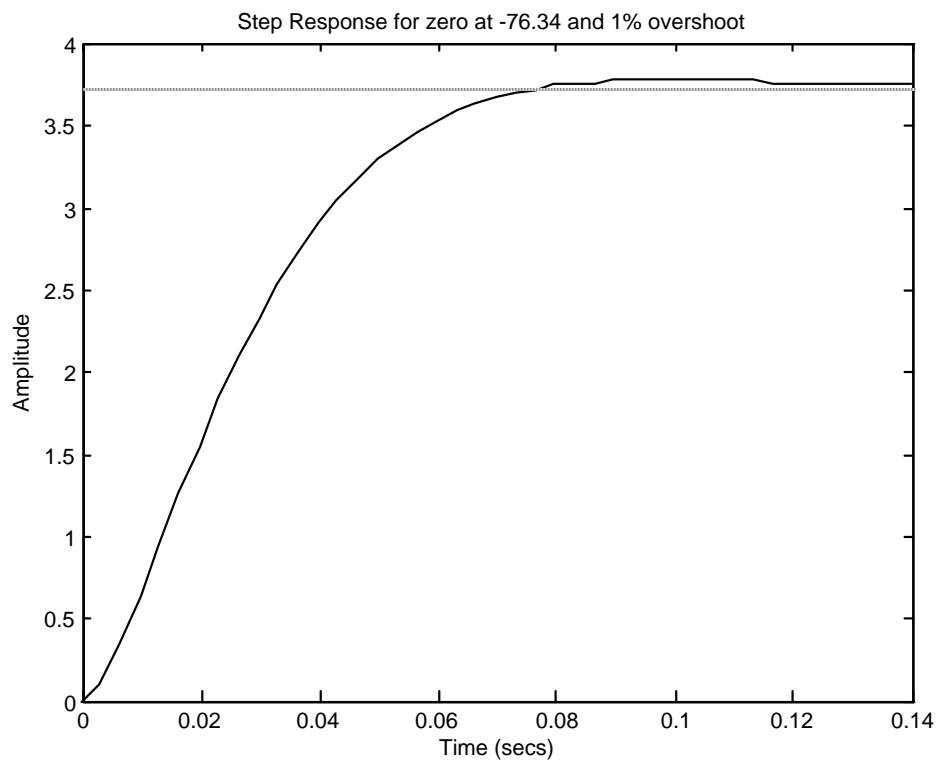

**b. PI compensator design:** To reduce the steady-state error to zero, we add a PI controller of the form  $\frac{s+1}{s}$ . The PID compensated step response is shown below.

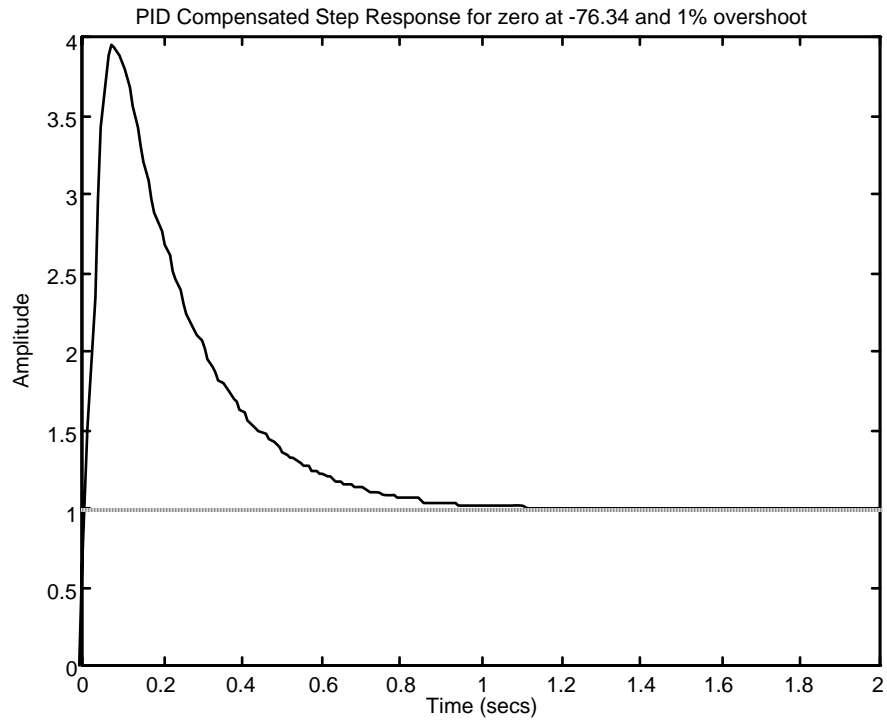

We can see the 1% overshoot at about 0.1 second as in the PD compensated system above. But the system now corrects to zero error.

51.

a. Root locus sketch yields;

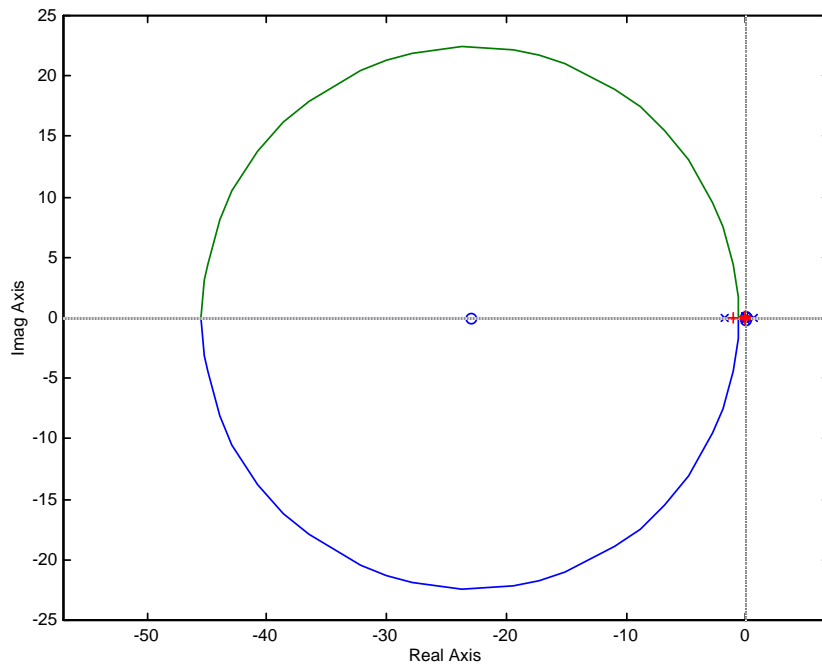

Root locus sketch near imaginary axis yields;

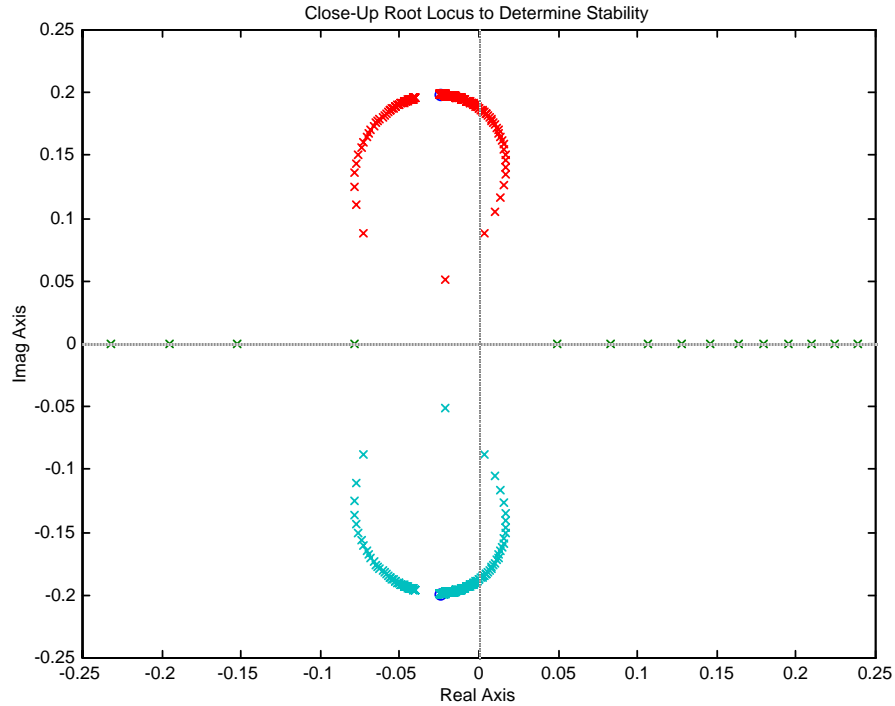

Searching imaginary axis for  $180^\circ$  yields:  $j0.083$  at a gain of  $0.072K = 0.0528$  and  $j0.188$  at a gain of  $0.072K = 0.081$ . Also, the gain at the origin is  $0.0517$ . Thus, the system is stable for  $0.0517 < 0.072K < 0.0528$ ;  $0.072K > 0.081$ . Equivalently, for  $0.7181 < K < 0.7333$ ;  $0.072K > 1.125$ .

**b.** See (a)

**c.** Uncompensated system: Searching the 20% overshoot line, we find the operating point at  $-8.987 + j17.4542 = 19.71 \angle 117.126^\circ$  at  $0.072K = 16.94$  for the uncompensated system. Simulating the response at this gain yields,

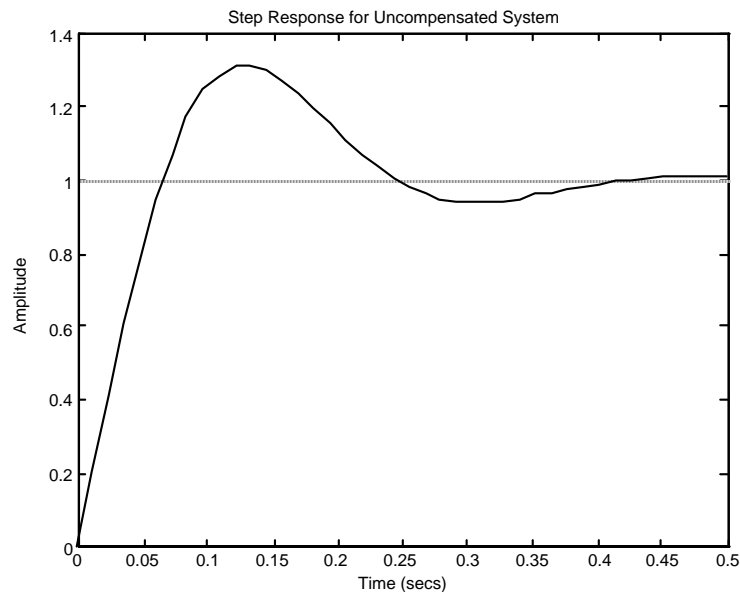

For 20% overshoot and  $T_s = 0.05$  s, a design point of  $-80 + j156.159$  is required. The sum of angles to the design point is  $-123.897^\circ$ . To meet the requirements at the design point, a zero would have to contribute  $+303.897^\circ$ , which is too high for a single zero. Let us first add the pole at the origin to drive the steady-state error to zero to reduce the angle required from the zero. Summing angles with this pole at the origin yields  $-241.023$ . Thus a zero contributing  $61.023^\circ$  is required. Using the geometry below with  $\frac{156.159}{z_c - 80} = \tan(61.023)$ ,  $z_c = 166.478$ .

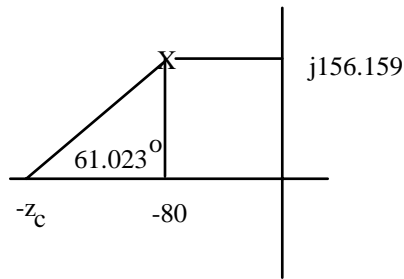

The gain at the design point is  $0.072K = 181.55$ .

d.

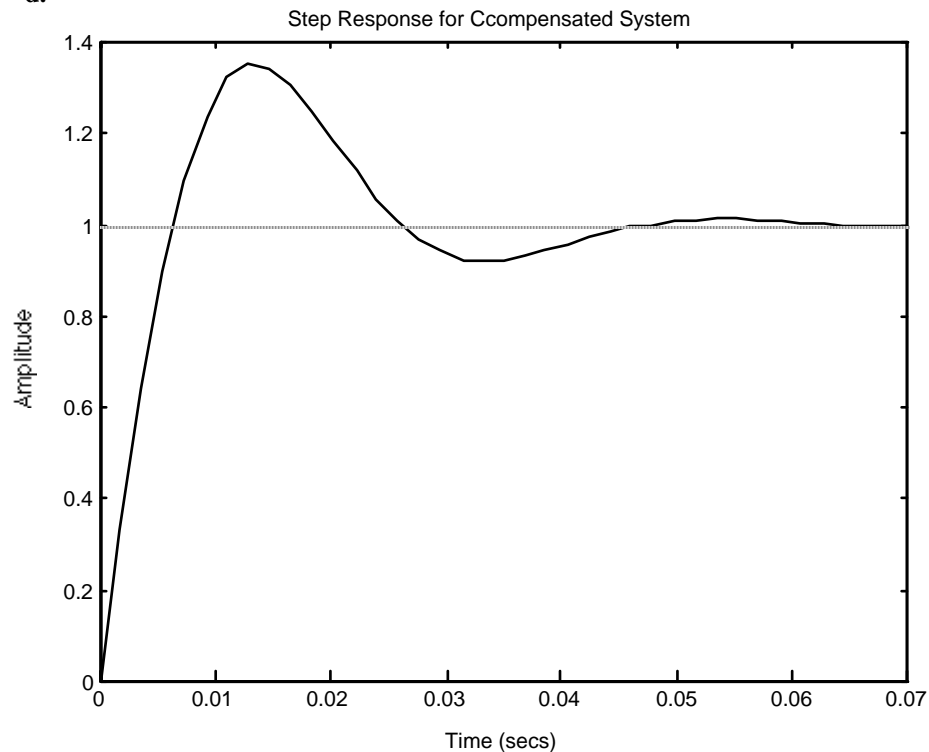

The settling time requirement has been met, but the percent overshoot has not. Repeating the design for 1% overshoot and a  $T_s = 0.05$  s yields a design point of  $-80 + j54.575$ . The compensator zero is found to be at  $-47.855$  at a gain  $0.072K = 180.107$ .

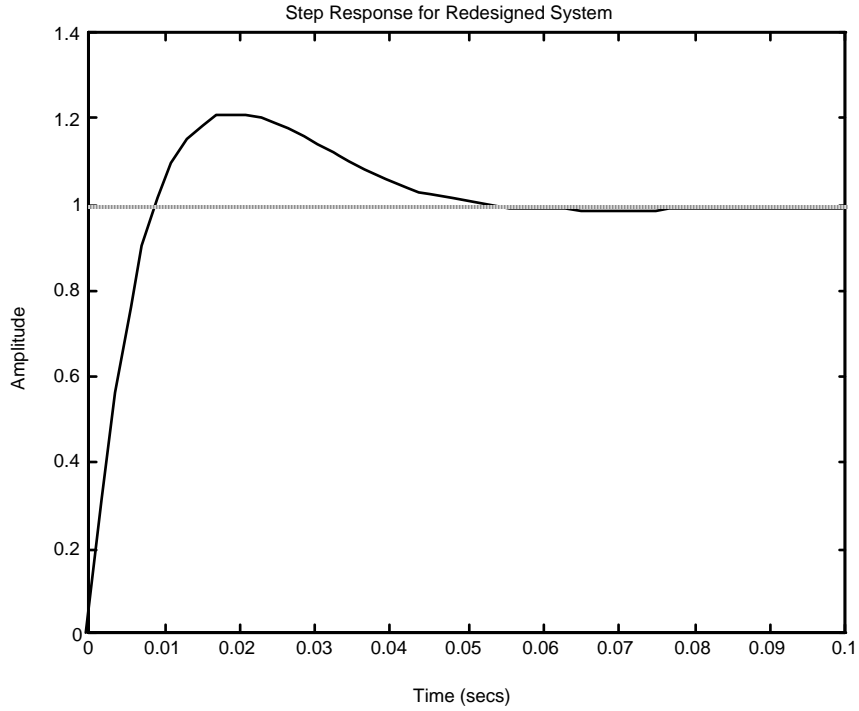

52.

$$\zeta \omega_n = \frac{4}{T_s} = 2.667; \zeta = \frac{-\ln\left(\frac{\%OS}{100}\right)}{\sqrt{\pi^2 + \ln^2\left(\frac{\%OS}{100}\right)}} = 0.591. \text{ Thus, } \omega_n = 4.512 \text{ rad/s.}$$

$$\text{Im} = \omega_n \sqrt{1 - \zeta^2} = 4.512 \sqrt{1 - 0.591^2} = 3.64. \text{ Thus, and the operating point is } -2.667 \pm j3.64.$$

Summation of angles, assuming the compensating zero is at  $-5$  (to cancel the open-loop pole at  $-5$ , is  $-170.88^\circ$ . Therefore, the compensator pole must contribute  $180^\circ - 170.88^\circ = 9.12^\circ$ . Using the geometry shown below,

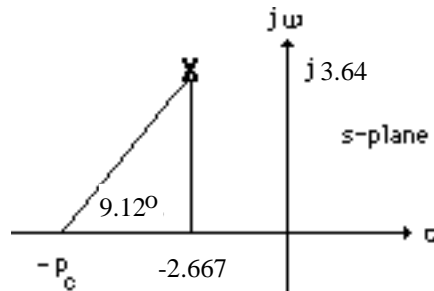

$$\frac{3.64}{p_c - 2.667} = \tan 9.12^\circ. \text{ Thus, } p_c = 25.34. \text{ Adding the compensator pole and using } -2.667 \pm j3.64 \text{ as the}$$

test point,  $50K = 2504$ , or  $K = 50.08$ . Thus the compensated open-loop transfer function is

$$G_e(s) = \frac{2504(s+5)}{s(s+5)(s^2+10s+50)(s+25.34)}$$

Higher-order pole are at  $-25.12$ ,  $-5$ , and  $-4.898$ . The

pole at  $-5$  is cancelled by the closed-loop zero at  $-5$ . The pole at  $-4.898$  is not far enough away from the dominant second-order pair. Thus, the system should be simulated to determine if the response meets the requirements.

**Program:**

```
syms s
numg=2504;
deng=expand(s*(s^2+10*s+50)*(s+25.34));
deng=sym2poly(deng);
G=tf(numg,deng);
Gzpk=zpk(G)
T=feedback(G,1);
step(T)
```

**Computer response:**

```
Zero/pole/gain:
      2504
-----
s (s+25.34) (s^2 + 10s + 50)
```

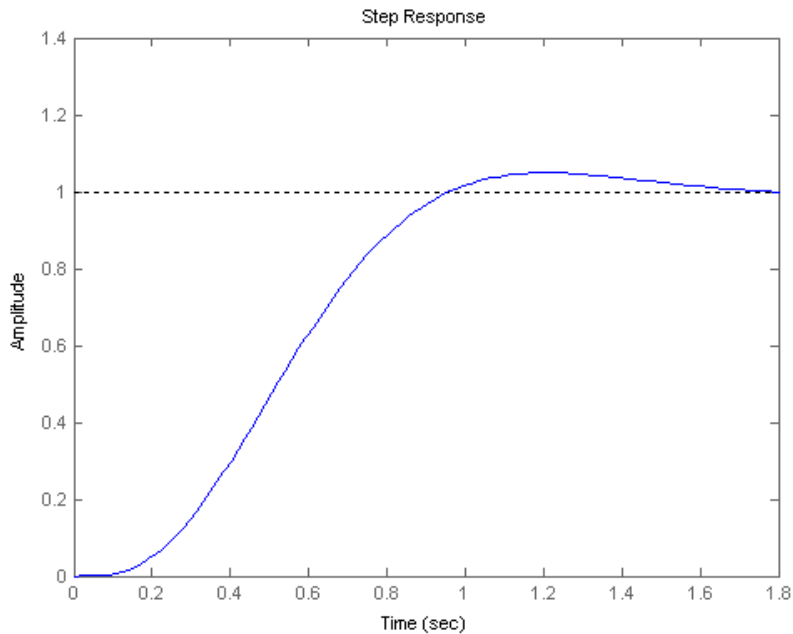

53.

a. We have that  $K_p = G(0) = 3(1.9078) = 5.7234$ . The steady state error for a unit step

input is  $e_{ss} = \frac{1}{1+K_p} = 0.15$

b. The required  $e_{ss} = 0.075$ , which corresponds to a  $K_p = \frac{1 - e_{ss}}{e_{ss}} = 12.33$ . Following the

procedure of Section 9.2, let  $\frac{z_c}{p_c} = \frac{K_{pN}}{K_{p0}} = \frac{12.33}{5.7234} = 2.2$ . Arbitrarily let  $p_c = 0.01$ , so

$$z_c = 0.022. \text{ The resulting compensator is } G_c(s) = \frac{3(s + 0.022)}{(s + 0.01)}$$

c. We decided to use SIMULINK for this simulation. The block diagram is given by:

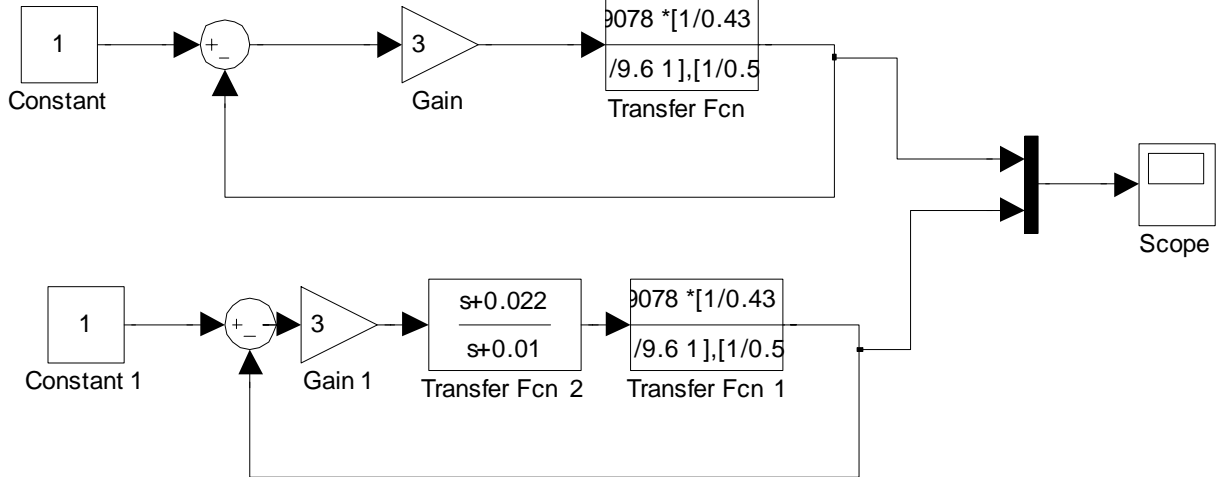

The resulting simulation shows the improvement in steady state error without affecting much the transient response.

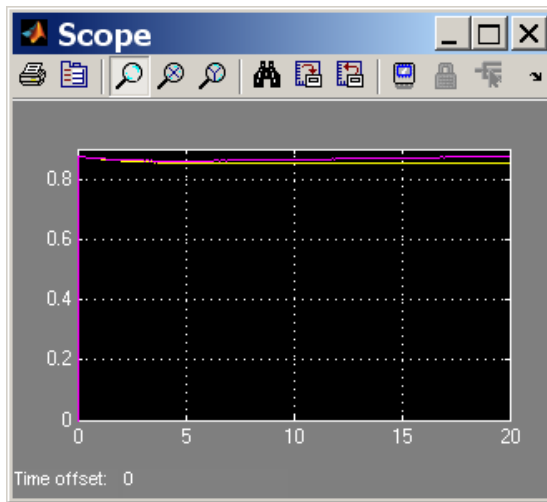

54.

- As can be seen from the entries in the first column of Table P9.54 below, we need to improve the steady-state error of this system as well as its transient response.



2. We design first the PD controller to meet transient response specifications. This includes the controller's zero location and gain:  $G_{PD}(s) = K_1 + K_3 s = K_3 \left( s + \frac{K_1}{K_3} \right) = K_3 (s + Z_c)$ .

We start by finding the desired operating point (dominant pole), corresponding to transient response specifications:

$$\zeta = \frac{-\ln(\% \text{O.S.}/100)}{\sqrt{\pi^2 + \ln^2(\% \text{O.S.}/100)}} = \frac{-\ln 0.04321}{\sqrt{\pi^2 + \ln^2(0.04321)}} = 0.707 \text{ corresponds to an overshoot of 4.321\%,}$$

which  $\leq 4.4\%$ .

The peak time of the PID-controlled system,  $T_p$ , should be less than that of the uncompensated system by  $\sim 20\%$ ;

e.g.;  $T_p \approx 0.8 \times 0.0207 = 0.01656$

$$\omega_d = \frac{\pi}{T_p} = \frac{\pi}{0.8 \times 0.0207} = 189.7 \text{ rad/sec}$$

The natural frequency should be:  $\omega_n = \frac{\omega_d}{\sqrt{1-\zeta^2}} = \frac{189.7}{\sqrt{1-0.707^2}} = 268.2 \text{ rad/sec}$ .

Hence, the desired operating point is:  $-\zeta\omega_n \pm j\omega_d = -189.7 \pm j 189.7$ .

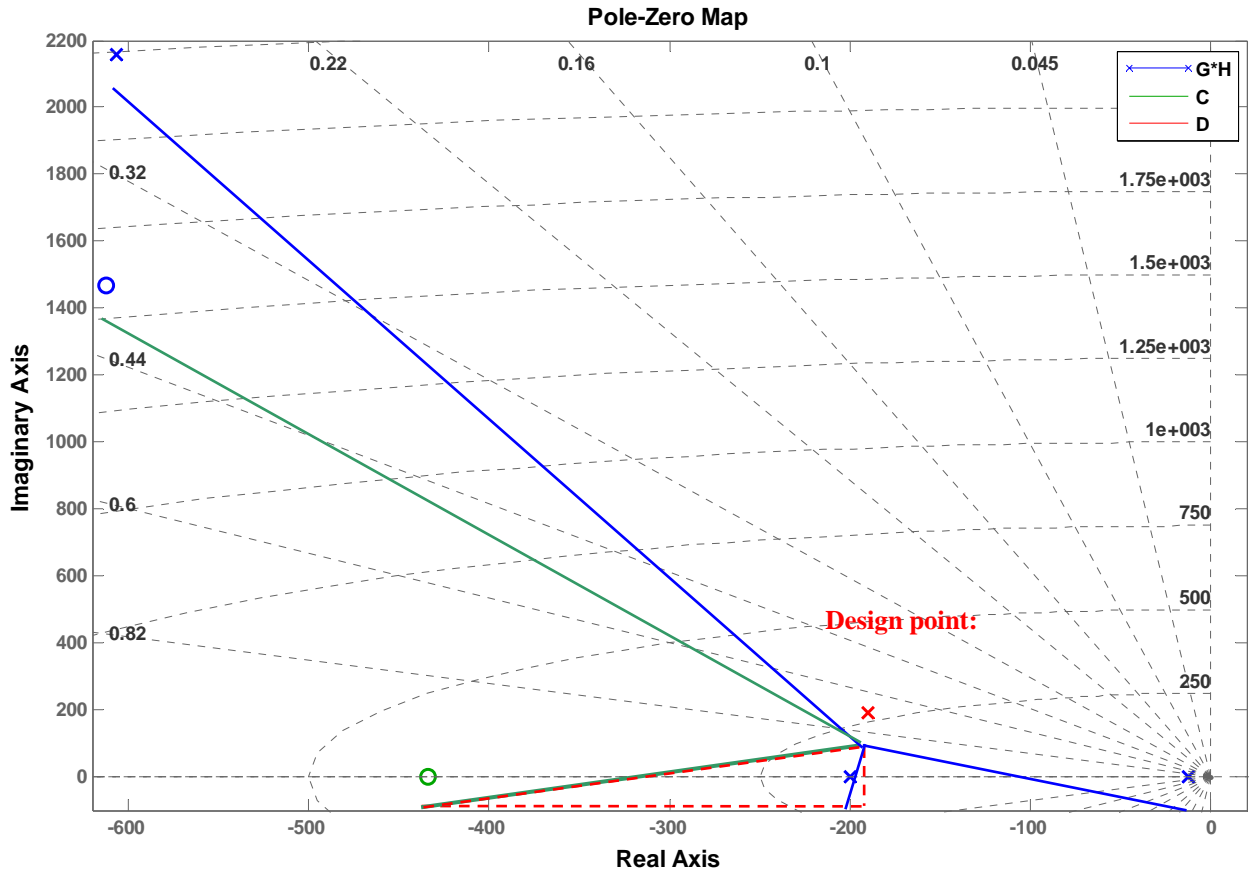

Next we design the PD controller. Using the geometry of the triangle shown in red in Figure above we calculate the compensating zero's location.

To use the root locus utility, we find the open-loop poles and zeros of the plant, e.g., the roots of the numerator and denominator of  $G_p(s)$ , which are:  $-12.5$ ,  $-606.3 \pm j 2155.8$ , and  $-612.5 \pm j 1467.9$ , respectively. As the coordinates of the desired dominant poles were entered, the sum of angles from the uncompensated system's poles and zeros to the desired compensated dominant pole was found to be  $-217.84^\circ$ . Thus, the contribution required from the PD compensator zero is  $-180^\circ + 217.84^\circ = 37.84^\circ$ . Hence:  $Z_c = 189.7 + \frac{189.7}{\tan 37.84^\circ} = 433.9$  and the

poles of the systems are determined by the equation  $1 + G_c(s) G_p(s)H(s) = 0$ , where

$$G_c(s)G_p(s)H(s) = \frac{25\,000 K_3 (s^2 + 1225 s + 2.53 \times 10^6)(s + 433.9)}{(s^3 + 1225 s^2 + 503 \times 10^4 s + 625 \times 10^5)(s + 200)}$$

is the open-loop function.

3. The following MATLAB M-file was written to simulate the system and plot its step response (shown below) to check whether all requirements may be met using a PD controller.

```

numg = 125*[1 1225 2.53E6];
deng = [1 1225 503E4 625E5];
Gp = tf(numg, deng);      %Gp is the transfer function (TF) of the plant
numh = 200;
denh = [1 200];
H = tf(numh, denh);      %H is the TF of the feedback low-pass filter
Zc = 433.9;
numgc = [1 Zc];
dengc = 1;
Gc = tf(numgc, dengc);   %Gc is the TF of the PD Controller
rlocus(Gp*Gc*H);
axis ([-250, 0, -250, 250]);
z=0.707;
sgrid(z,0)
title('Root Locus Zoomed-in around Dominant Poles with a 0.707 Damping Line')
[K1,p]=rlocfind(Gp*Gc*H);
pause
K = K1;
T=feedback((K*Gc*Gp),H); %T is the closed-loop TF of the system
step(750*T);
axis ([0, 0.04, 0, 1300]);
grid
title(['Step Response of PD-cont. Bus Voltage for Zc = - ', num2str(Zc)]);

```

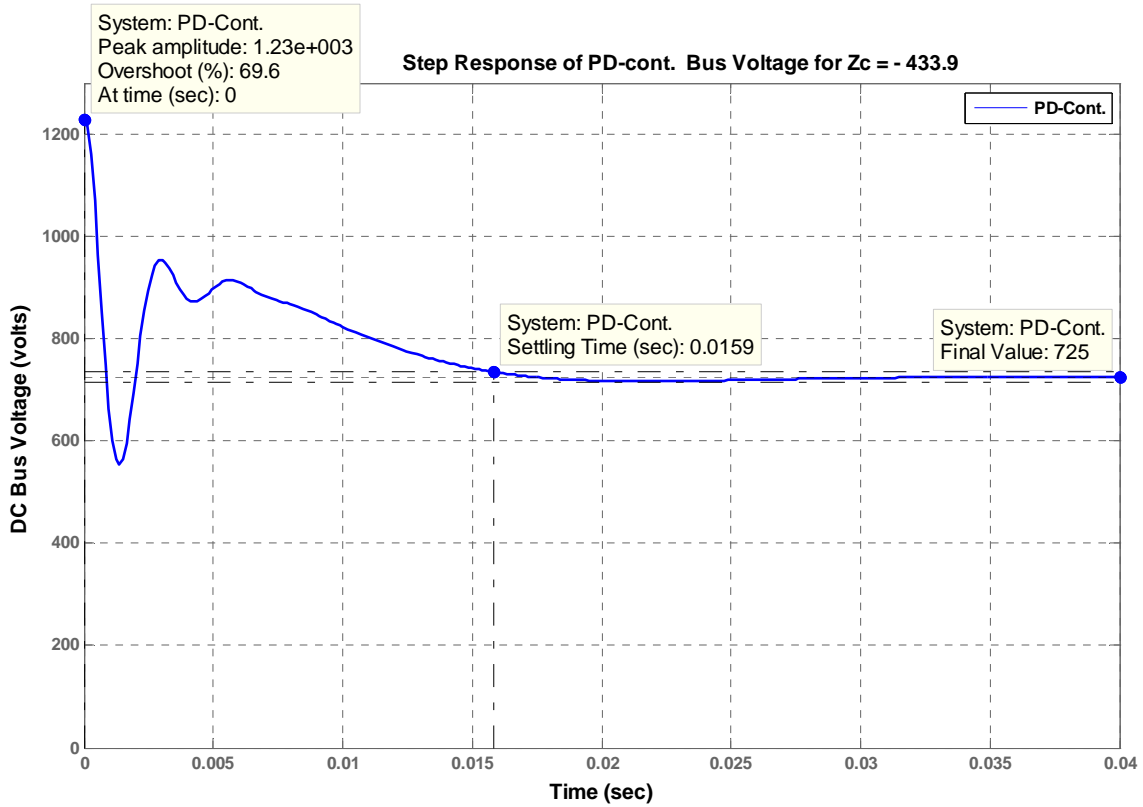

4. As could be seen from the above graph, the settling time,  $T_s$ , has been reduced significantly, but the overshoot is extremely high. Therefore, other values of the PD controller's zero were tested to get a satisfactory transient response or, at least, the best possible one, with the idea that the transient may be improved further by adjusting the zero that will be added later in the following step (associated with the PI controller), since reducing the steady-state error to zero, requires the addition of an integral mode.

The two graphs obtained for the PD controller's zero at  $Z_c = - 800$  and at  $- 2000$  are shown below. It could be seen from these graphs that the response of the PD-controlled system with  $Z_c = - 800$  is faster and its peak time,  $T_p = 0.0142$  sec, satisfies that requirement.

Therefore, the results obtained for  $Z_c = - 800$  were added to Table P9.54 below as entries, which characterize the PD-compensated system.

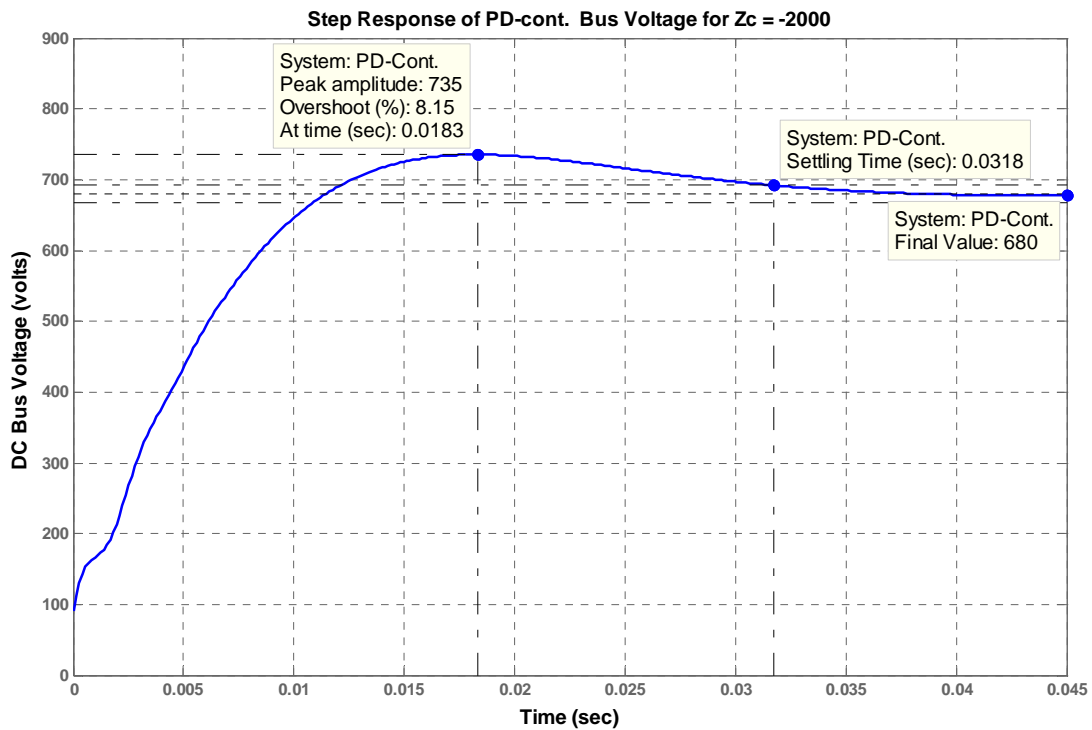
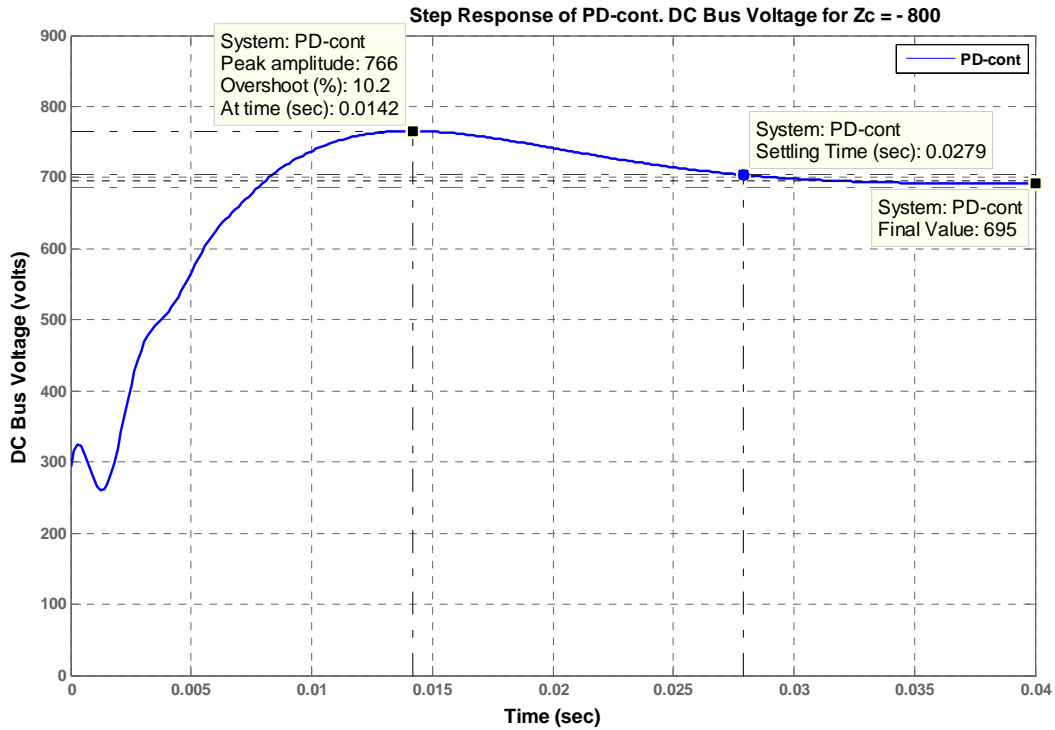

5. Adding the PI controller will introduce a pole at the origin, which will have a negative effect on the transient response. To minimize that effect we place a zero ( $G_{PI}(s) = K_1 + \frac{K_2}{s} = \frac{K_1s + K_2}{s} = \frac{K_1(s + Z_{PI})}{s}$ ),  $Z_{PI} = K_2/K_1$ , close to that pole. The poles of the system are determined by the equation  $1 + G_c(s)G_p(s)H(s) = 0$ , where

$$G_c(s)G_p(s)H(s) = \frac{25000K(s^2 + 1225s + 2.53 \times 10^6)(s + 800)(s + Z_{PI})}{s(s^3 + 1225s^2 + 503 \times 10^4s + 625 \times 10^5)(s + 200)}.$$

The following MATLAB M-file was written to add the integral mode. It was run a few times with various values of the PI controller's zero,  $Z_{PI}$ , (between zero and the closest open-loop pole at -12.5) to check whether all requirements are met using a PID controller.

```

numg = 125*[1 1225 2.53E6];
deng = [1 1225 503E4 625E5];
Gp = tf(numg, deng);      %Gp is the transfer function (TF) of the plant
numh = 200;
denh = [1 200];
H = tf(numh, denh);      %H is the TF of the feedback low-pass filter
Zc = 800;
Zi = 4;
numgc = poly([-Zi, -Zc]);
dengc = [1 0];
Gc = tf(numgc, dengc);   %Gc is the TF of the PID Controller
rlocus(Gp*Gc*H);
axis([-200, 0, -200, 200]);
z=0.707;
sgrid(z,0)
title('Root Locus Zoomed-in around Dominant Poles with a 0.707 Damping Line')
[K1,p]=rlocfind(Gp*Gc*H);
pause
K = K1;
T=feedback((K*Gc*Gp),H); %T is the closed-loop TF of the system
step(750*T);

```

```
axis ([0, 0.4, 0, 850]);
grid
title(['Step Response of PID-cont. of DC Bus for Zc = ', num2str(Zc), ' and Zi
= - ', num2str(Zi), ']);
```

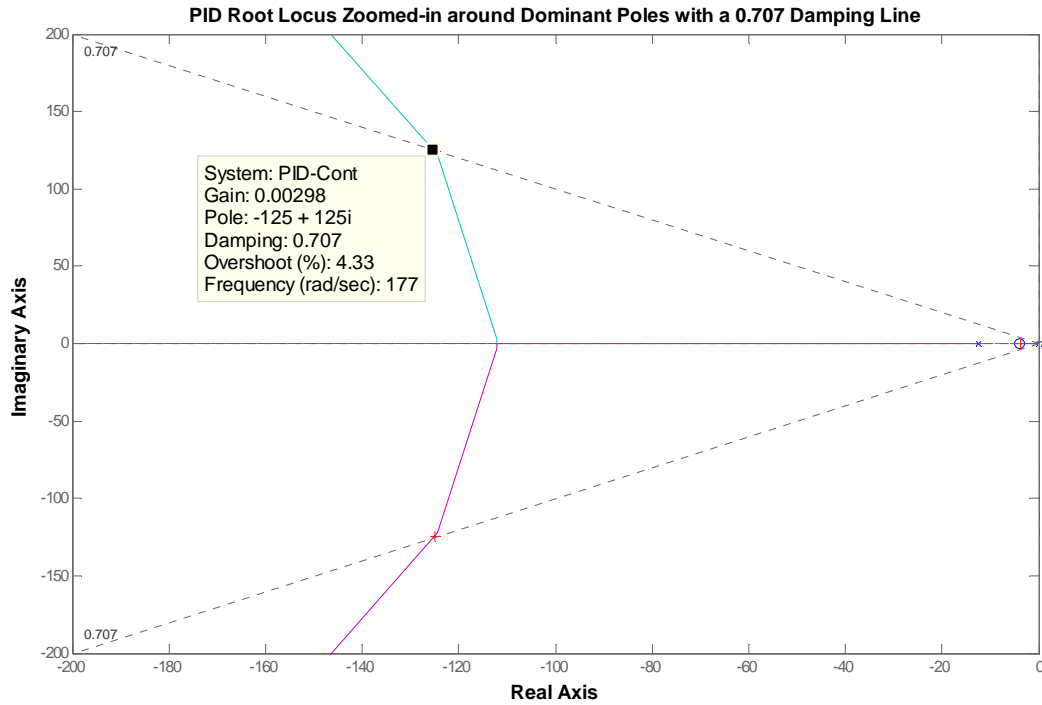

6. As a result, the following transfer function of the PID controller was found:

$$G_c(s) = 0.003 \times \left( \frac{s^2 + 804s + 3200}{s} \right) = \frac{K_3 \left( s^2 + \frac{K_1}{K_3}s + \frac{K_2}{K_3} \right)}{s}$$

Thus, the gains,  $K_1$ ,  $K_2$ , and  $K_3$  are:  $K_3 = 0.003$ ;  $K_1 = 2.41$ ; and  $K_2 = 9.6$ .

7. The system simulation showed that all steady-state and transient response requirements have been met (see the figure below and Table P9.54).

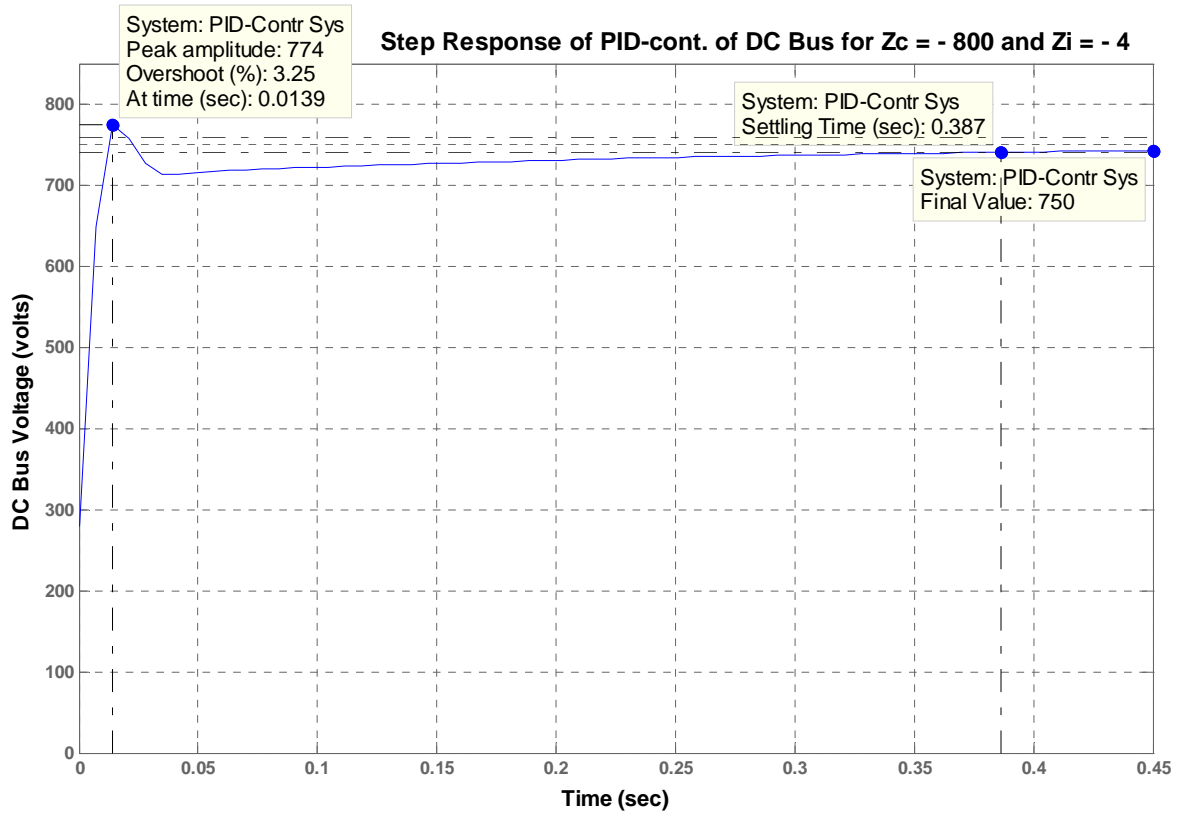

8. All requirements have been met. No need for any redesign.



Table P9.54

	Uncompensated	PD-compensated	PID-compensated
Plant & Compensator TF, $G_c(s)G_p(s)H(s)$	$\frac{25000K(s^2 + 1225s + 2.53 \times 10^6)}{(s^3 + 1225s^2 + 503 \times 10^4s + 625 \times 10^5)(s + 200)}$	$\frac{25000K(s^2 + 1225s + 2.53 \times 10^6)(s + 800)}{(s^3 + 1225s^2 + 503 \times 10^4s + 625 \times 10^5)(s + 200)}$	$\frac{25000K(s^2 + 1225s + 2.53 \times 10^6)(s + 800)(s + 4)}{s(s^3 + 1225s^2 + 503 \times 10^4s + 625 \times 10^5)(s + 200)}$
Dominant Poles	$-108.5 \pm j 108.5$	$-130.6 \pm j 130.6$	$-125 \pm j 125$
Proportional Gain, $K = K_1$	1.675	1.498	2.41
Damping Coefficient, $\zeta$	0.707	0.707	0.707
Natural Frequency, $\omega_n$	153.47 rad/sec	184 rad/sec	177 rad/sec
Percent Overshoot, %OS	7.31%	10.2%	3.25%
Peak Time, $T_p$	0.0207 sec	0.0142 sec	0.0139 sec
Settling Time, $T_s$	0.0338 sec	0.0279 sec	0.387 sec
Static Error Constant, $K_p$	8.494	12.549	$\infty$
Steady-state Error, $e_{v\text{step}}(\infty)$	10.53%	7.38%	0%
Other Poles	$-604.0 \pm j 2160.2$	$-623.6 \pm j 2166.0$	$-622.7 \pm j 2165.5, -3.8$
Zeros	$-612.5 \pm j 1467.9$	$-200, -612.5 \pm j 1467.9, -800$	$-4, -200, -612.5 \pm j 1467.9, -800$

Comments	Second-order Approximation OK	Zeros at $-200$ & $-800$ not cancelled	Zeros at $-4$ , $-200$ , and $-800$ not cancelled

55.

a. From Chapter 8,

$$G_c(s) = \frac{0.6488K (s+53.85)}{(s^2 + 8.119s + 376.3) (s^2 + 15.47s + 9283)}$$

Cascading the notch filter,

$$G_{et}(s) = \frac{0.6488K (s+53.85)(s^2 + 16s + 9200)}{(s^2 + 8.119s + 376.3) (s^2 + 15.47s + 9283)(s+60)^2}$$

Arbitrarily design for %OS = 30% ( $\zeta = 0.358$ ) and  $T_s = 0.3$  s. This places desired poles at $-13.33 \pm j34.79$ . At the design point, the sum of the angles without the PD controller is  $107.19^\circ$ . Thus,

$$\frac{34.79}{z_c - 13.33} = \tan 72.81$$

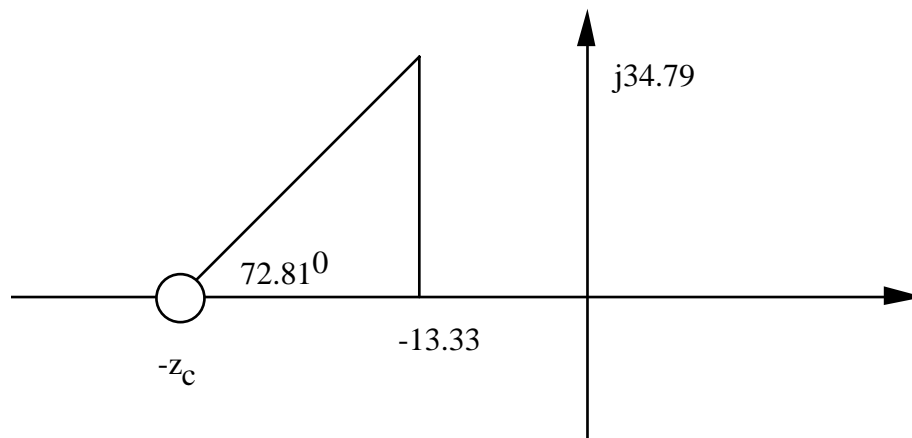

From which,  $z_c = 24.09$ . Putting this into the forward path,

$$G_{et}(s) = \frac{0.6488K (s+53.85)(s^2 + 16s + 9200)(s+24.09)}{(s^2 + 8.119s + 376.3) (s^2 + 15.47s + 9283)(s+60)^2}$$

Using root locus, the gain  $0.6488K = 1637$ , or  $K = 2523$ .

**b.** Add a PI controller

$$G_{PI}(s) = \frac{(s+0.1)}{s}$$

Thus,

$$G_{et}(s) = \frac{0.6488K (s+53.85)(s^2 + 16s + 9200)(s+24.09)(s+0.1)}{s (s^2 + 8.119s + 376.3) (s^2 + 15.47s + 9283)(s+60)^2}$$

Using root locus, the gain  $0.6488K = 1740$ , or  $K = 2682$ .

**c.**

**Program:**

```
syms s
numg=1637*(s+53.85)*(s^2+16*s+9200)*(s+24.09)*(s+0.1);
deng=s*(s^2+15.47*s+9283)*(s^2+8.119*s+376.3)*(s+60)^2;
numg=sym2poly(numg);
deng=sym2poly(deng);
G=tf(numg,deng);
Gzpk=zpk(G)
T=feedback(G,1);
step(T,0:0.01:1)
title(['With PD, Notch, and PI'])
pause
step(T)
title(['With PD, Notch, and PI'])
```

**Computer response:**

Zero/pole/gain:

$$\frac{1637 (s+53.85) (s+24.09) (s+0.1) (s^2 + 16s + 9200)}{s (s+60)^2 (s^2 + 8.119s + 376.3) (s^2 + 15.47s + 9283)}$$

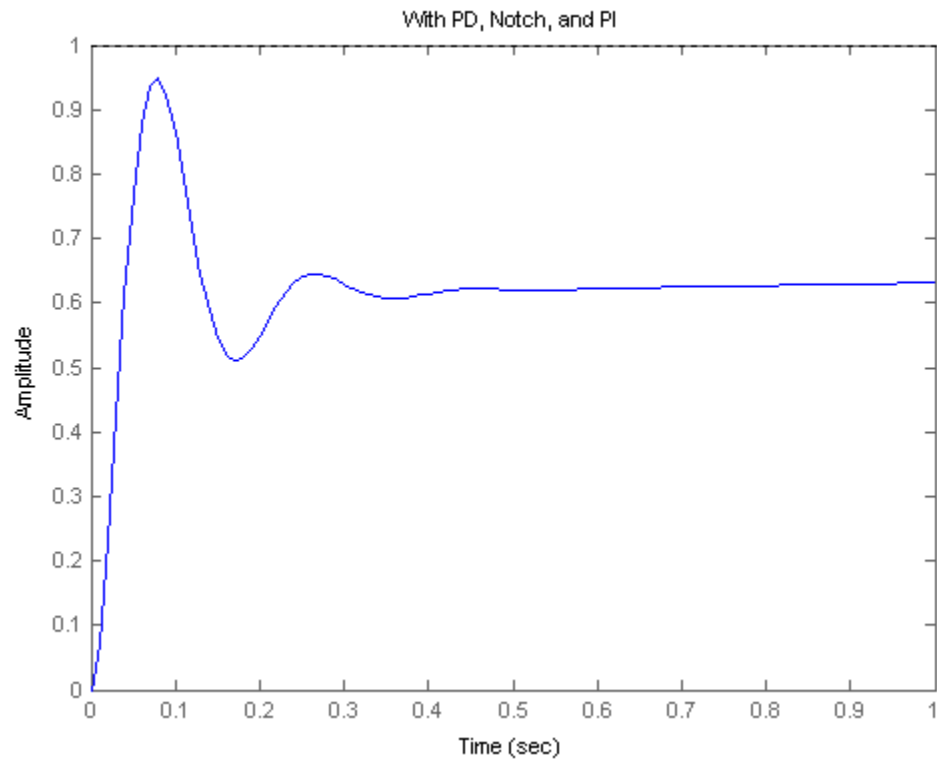

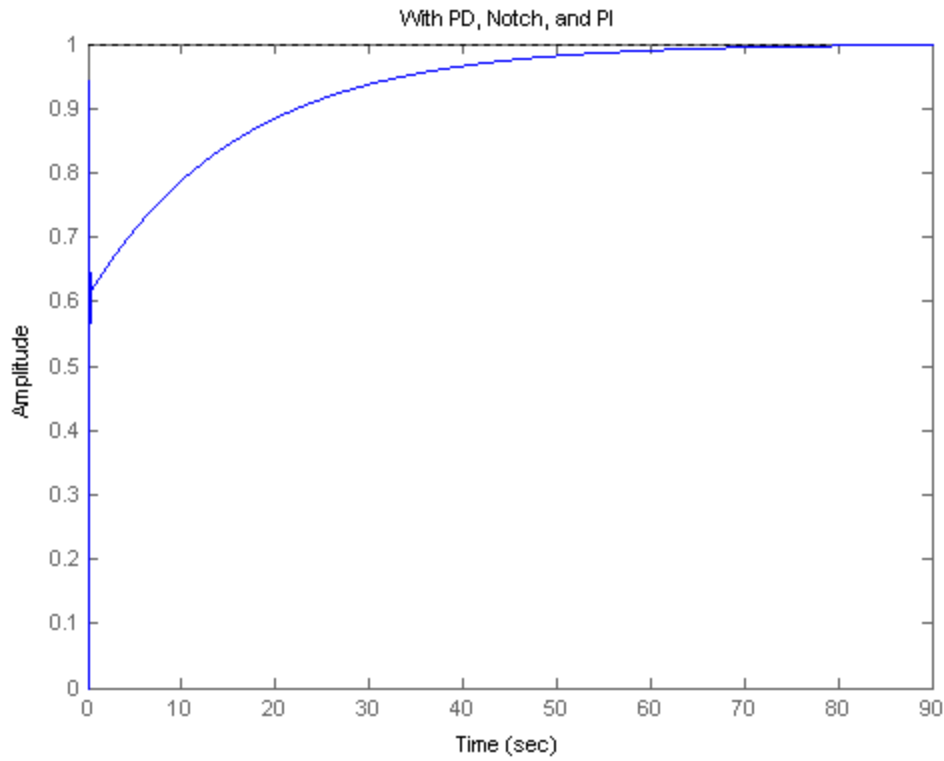

56.

a. The root locus for the uncompensated system was obtained in Chapter 8 . It was shown there that the system is closed loop stable for all  $K>0$  .

All the poles are real when  $K = -0.00331$  .

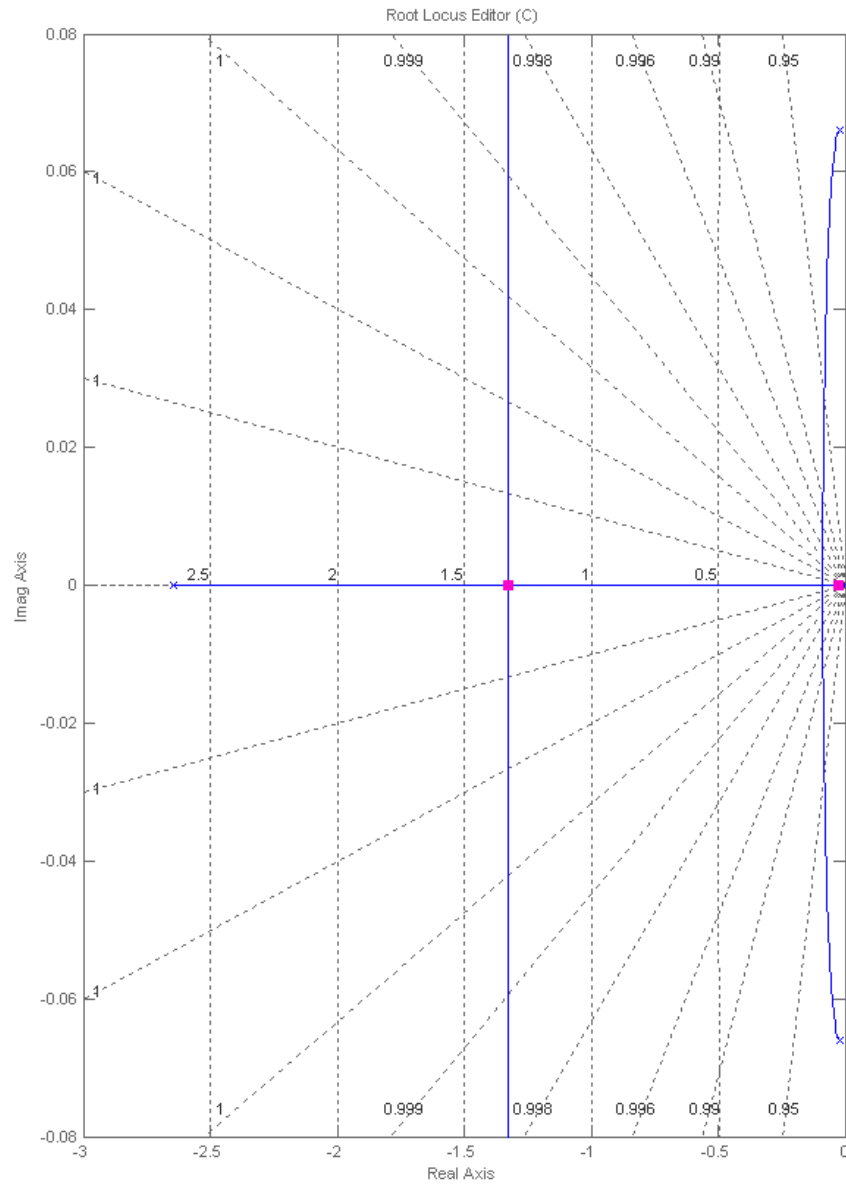

The step response simulation:

```
>> syms s
```

```
>> s=tf('s');
```

```
>> P=(520*s+10.3844)/(s^3+2.6817*s^2+0.11*s+0.0126);
```

```
>> Gc = 0.00331;
```

```
>> T=Gc*P/(1+Gc*P);
```

```
>> step(T)
```



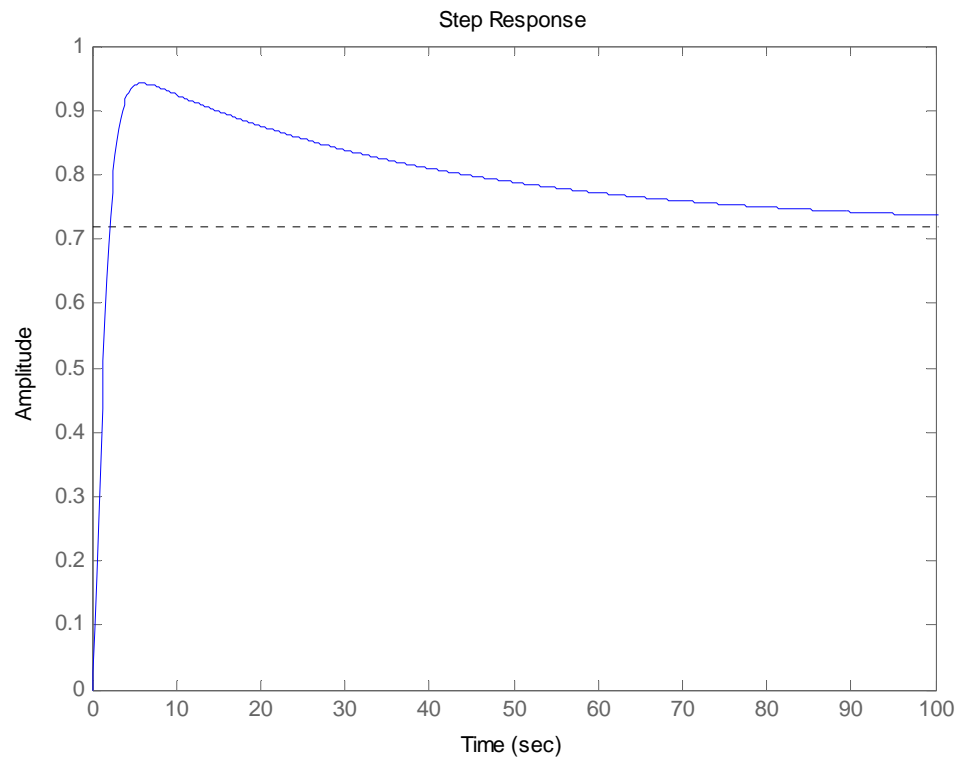

The measured %OS=31% and  $T_s \approx 100\text{sec}$

**b.** A pole is placed at the origin and a zero is arbitrarily placed at -0.1, since the system has a pole very close to the origin ( $z=-0.02$ ), it may serve as the compensator's zero. The resulting compensator is  $G_c(s) = \frac{0.00189(s + 0.1)}{s}$ . The root locus is shown next:



```
>> syms s
>> s=tf('s');
>> P=(520*s+10.3844)/(s^3+2.6817*s^2+0.11*s+0.0126);
>> Gc=0.00189*(s+0.1)/s;
>> T=Gc*P/(1+Gc*P);
>> step(T,100)
```

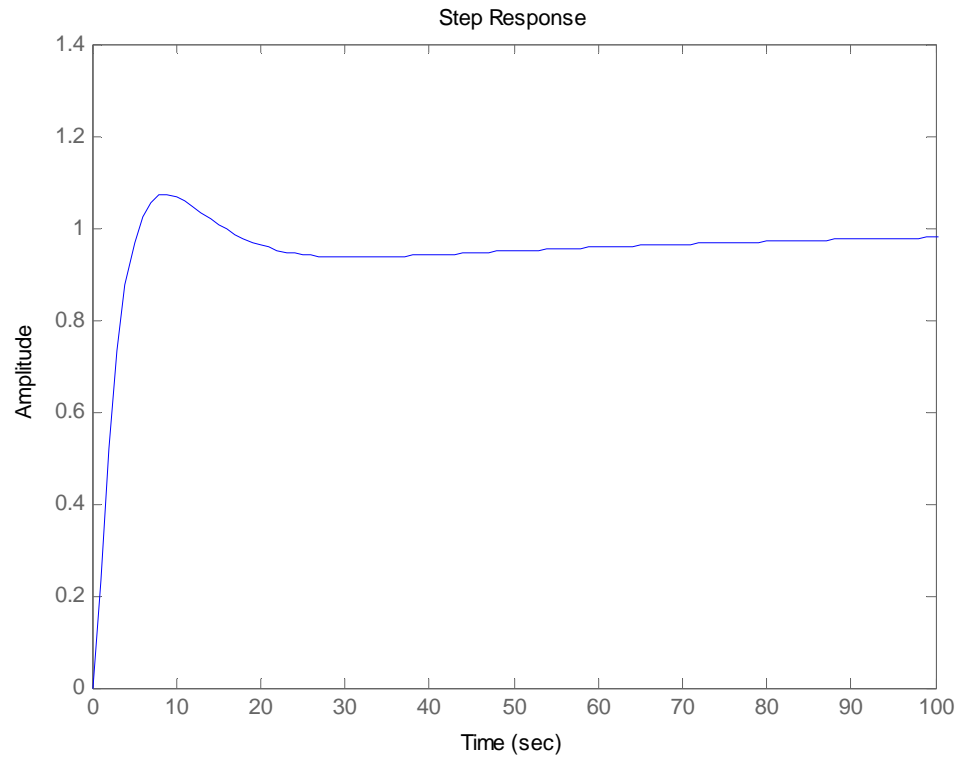

%Os=7% and  $T_s \approx 100\text{sec}$

57.

- a. To determine the improvements required in the transient and steady-state responses of the uncompensated system, its performance characteristics, obtained in part (a) of problem 8.71 are entered into Table P9.57 which is given at the end of part (b) below. To plot  $c(t)$  for  $r(t) = 4 u(t)$ , volts, the MATLAB M-file developed for part (a) of problem 8.71 was modified as shown below:

```
numg = [1 0.6];  
deng = poly ([-0.0163 -0.5858]);  
G = tf(numg, deng);  
rlocus(G);  
axis ([-0.8, 0.1, -0.1, 0.1]);  
pos=(0);  
z=-log(pos/100)/sqrt(pi^2+(log(pos/100))^2);  
sgrid(z,0)  
title(['Root Locus with ', num2str(pos) , ' Percent Overshoot Line'])  
[K1,p]=rlocfind(G);  
pause  
T=feedback(K1*G,1); %Tu is the closed-loop TF of the uncompensated system  
T=minreal(T);  
step(4*T);  
xlabel ('Time')  
ylabel ('Speed Sensor Output, c(t) in volts')  
title (['Step Response of Uncompensated System at K = ', num2str(K1), ' to a 4 volt Input Step'])  
grid
```

The step response,  $c(t)$ , of the uncompensated system to  $r(t) = 4 u(t)$  is shown below. As could be seen from the plot and the entries made into Table P9.57, the uncompensated system does not meet any of the steady-state requirements – the need to reduce  $e_{step}^1(\infty)$  from 2% to the required 0% and to have a finite value for the steady-state error due a ramp input,  $e_{ramp}(\infty) = 2\%$ , indicate that the system should become type-1, e.g. an integral mode should be added to the controller. The speed of response also is not adequate – the rise time is 2.69 seconds and the settling time is 4.69 seconds whereas the compensated system is required to have a settling time equal to or less than four seconds.

---

$$^1 e_{step}(\infty) = \frac{r(\infty) - c(\infty)}{r(\infty)} \times 100 = \frac{4 - 3.92}{4} \times 100 = 2\%$$

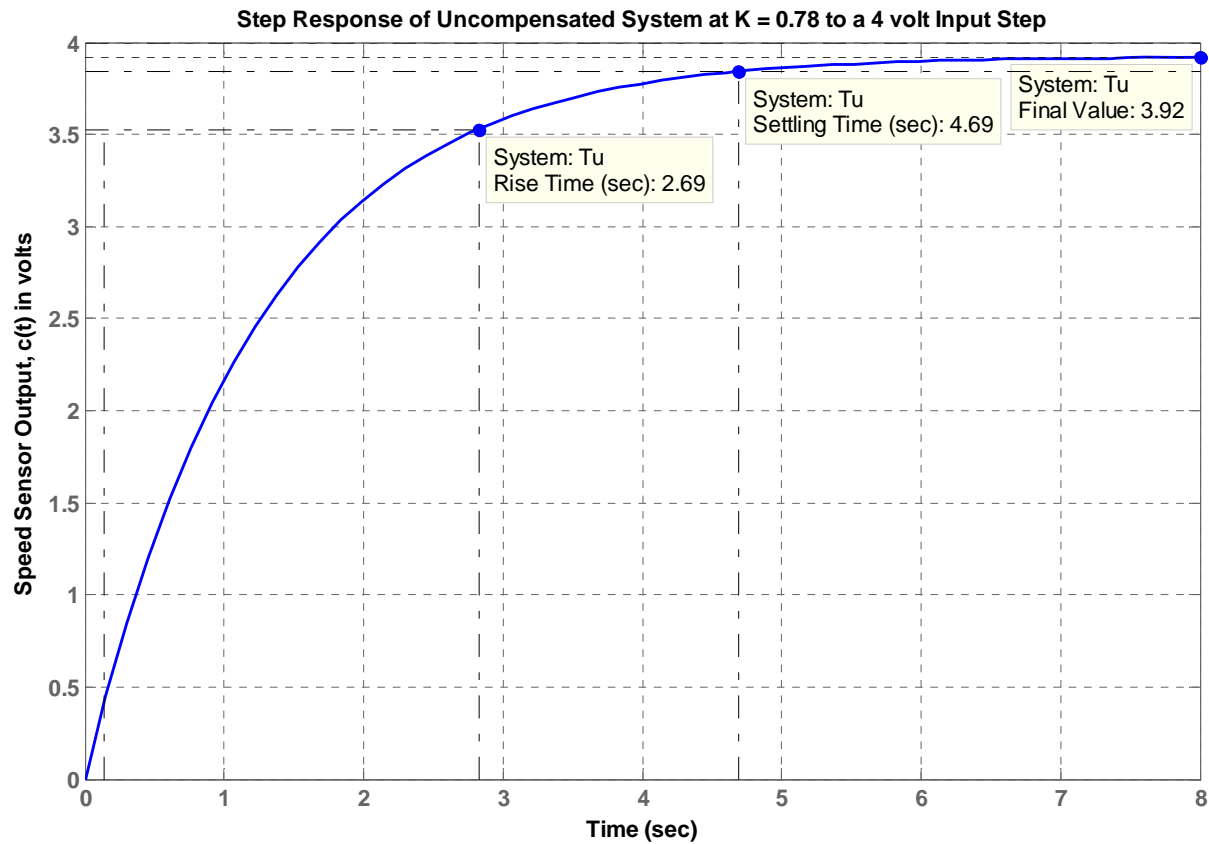

- b. We now design the PI-controller to obtain a steady-state error,  $e_{\text{step}}(\infty) = 0$ , for a step input,  $r(t) = 4 u(t)$  and a steady-state error for a unit-ramp input,  $e_{\text{ramp}}(\infty) \leq 2\%$ .

To achieve that and at the same time either improve or have a minor negative effect on the transient response of the system, we need to place the PI-controller's zero on-top or close to the dominant pole of the uncompensated system, located at  $-0.0163$ . Hence, we'll start by assuming that the transfer

function of the PI-controller is: 
$$G_{SC}(s) = K_1 + \frac{K_2}{s} = \frac{K_1 \left[ s + \left( \frac{K_2}{K_1} \right) \right]}{s} = \frac{K_1 \times (s + 0.0163)}{s}$$

Thus, we obtain a type-1 system with a transfer function<sup>1</sup> of the “Plant & Compensator” given by:  $G(s) = \frac{K_1(s+0.6)}{s(s+0.5858)}$ , which has a “position” error constant  $K_P = \lim_{s \rightarrow 0} G(s) = \infty$  and a “velocity” error constant,  $K_V = \lim_{s \rightarrow 0} sG(s) = 1.024 K_1$ .

Hence, the requirement to have a zero steady-state error for a step input,  $r(t) = A u(t) = 4 u(t)$  is satisfied, since:  $e_{step}(\infty) = \frac{A}{1+K_P} = \frac{4}{1+\infty} = 0$ .

The requirement that  $e_{ramp}(\infty) \leq 2\%$ , for a unit-ramp input will be satisfied if  $e_{ramp}(\infty) = \frac{1}{K_V} = \frac{1}{1.024 K_1} \leq 0.02$ , e.g., if  $K_1 \geq 48.83$ . At this value of  $K_1$ , the open-loop transfer function of the PI-compensated system is:  $G(s) = \frac{48.83s + 29.3}{s(s+0.5858)}$ .

The following MATLAB file was written to check whether all requirements have been met:

```
numg = [48.83 29.3];
deng = poly([0 -0.5858]);
G = tf(numg, deng);
T = feedback(G,1);    %T is the closed-loop TF of the PI_compensated system
T = minreal(T);
step(4*T);
```

---

<sup>1</sup> Enter this transfer function and the results obtained for the PI-compensated system into Table P9.57.



```
axis ([0, 0.2, 0, 5]);  
  
grid  
  
xlabel ('Time')  
  
ylabel ('Speed Sensor Output, c(t) in volts')  
  
title ('PI-compensated Systems Response to a 4 volt Input Step')  
  
pause  
  
numr = 1;  
  
denr = poly (0);  
  
R = tf(numr, denr);  
  
T2 = R*T;  
  
E= R-T2;           %E = Ramp error of PI_compensated system  
  
step(T2,'b', R,'g', E,'r');  
  
axis ([0, 5, 0, 5]);  
  
grid  
  
xlabel ('Time')  
  
ylabel ('Output Rate, dc(t)/dt, V/s (Blue); Unit Ramp (Green); Error (Red)');  
  
title ('Response of PI-compensated System to a Unit-ramp Input')
```

The step response,  $c(t)$ , and the unit-ramp response,  $dc(t)/dt$ , of the PI-compensated system are shown below. As could be seen from the plots and the entries made into Table P.9.57, the PI-compensated system satisfies all performance requirements. Its steady-state error for a step input,  $r(t) = 4 u(t)$ , is zero and the value of its steady-state error due a unit-ramp input,  $e_{ramp}(\infty) = 0.02 = 2\%$ .

It has also an extremely fast speed of response – the rise time is 0.045 seconds and the settling time is 0.08 seconds. Since the PI-compensated system satisfies all performance requirements, there is no need to add a derivative mode. Therefore, Table P.9.57, shown below has been limited to entries for the uncompensated and PI-compensated systems only.

It should be noted, however, that the rise and settling times obtained seem to be unrealistic for the reasons noted above. Therefore, the Simulink model (which was developed originally for problem 5.81) was modified as shown above and will be run in step (c).

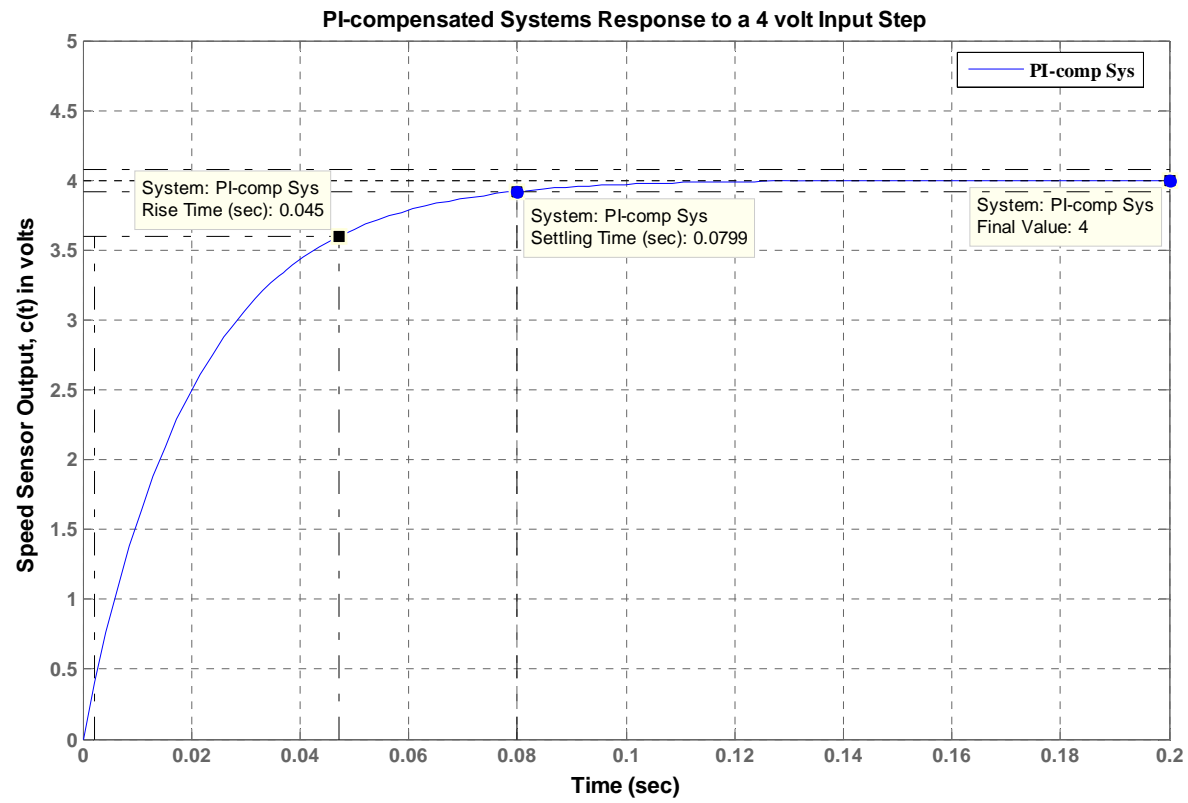

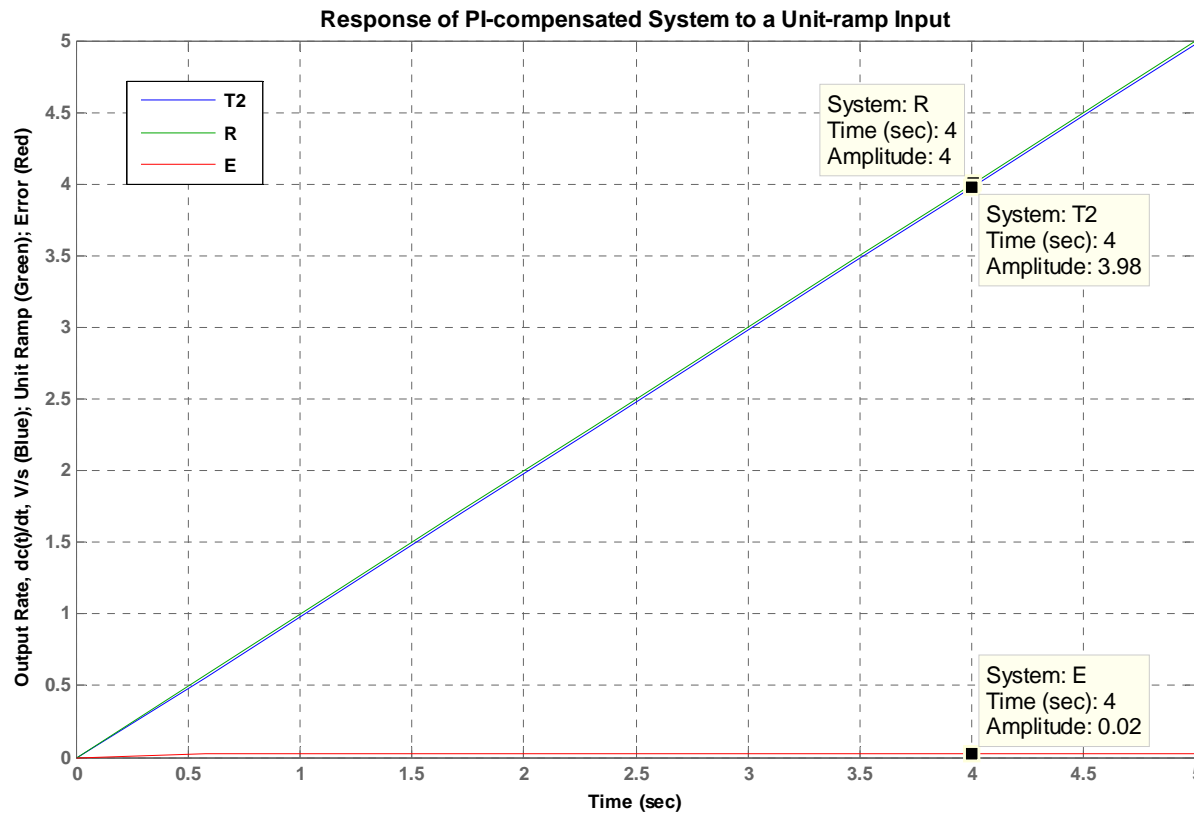

**Table P9.57 Characteristics of Uncompensated and PI-compensated Systems**

Table P9.57

	<b>Uncompensated</b>	<b>PI-compensated</b>
Plant & Compensator, $G(s)$	$\frac{K_1(s+0.6)}{(s+0.5858)(s+0.0163)}$	$\frac{K_1(s+0.6)}{s(s+0.5858)}$
Closed-loop Transfer Function, $T(s)$	$\frac{0.78s+0.468}{s^2+1.382s+0.4775}$	$\frac{48.83s+29.3}{s^2+49.42s+29.3}$
Dominant Pole(s)	-0.691, -0.691	-48.82
Proportional Gain, $K$	$K = K_1 = 0.78$	$K_1 = 48.83$
Damping Coefficient, $\zeta$	1	1
Rise Time, $T_r$	2.69 sec	0.045 sec
Settling Time, $T_s$	4.69 sec	0.08 sec
$e_{\text{step}}(\infty)$	2%	0
$e_{\text{ramp}}(\infty)$	$\infty$	2%
Other Poles	none	-0.6002

Zeros	- 0.6	- 0.6
Comments	Second-order Critically-damped System	Second-order <sup>1</sup> Over-damped System

c. We now run the following Simulink model, which includes a saturation element placed at the output of the motor armature, which was set to an upper limit of 250 A.

---

<sup>1</sup> With the second closed-loop pole very small (compared to the dominant pole) and almost equal to the system's zero, this system acts almost as a first-order lag.

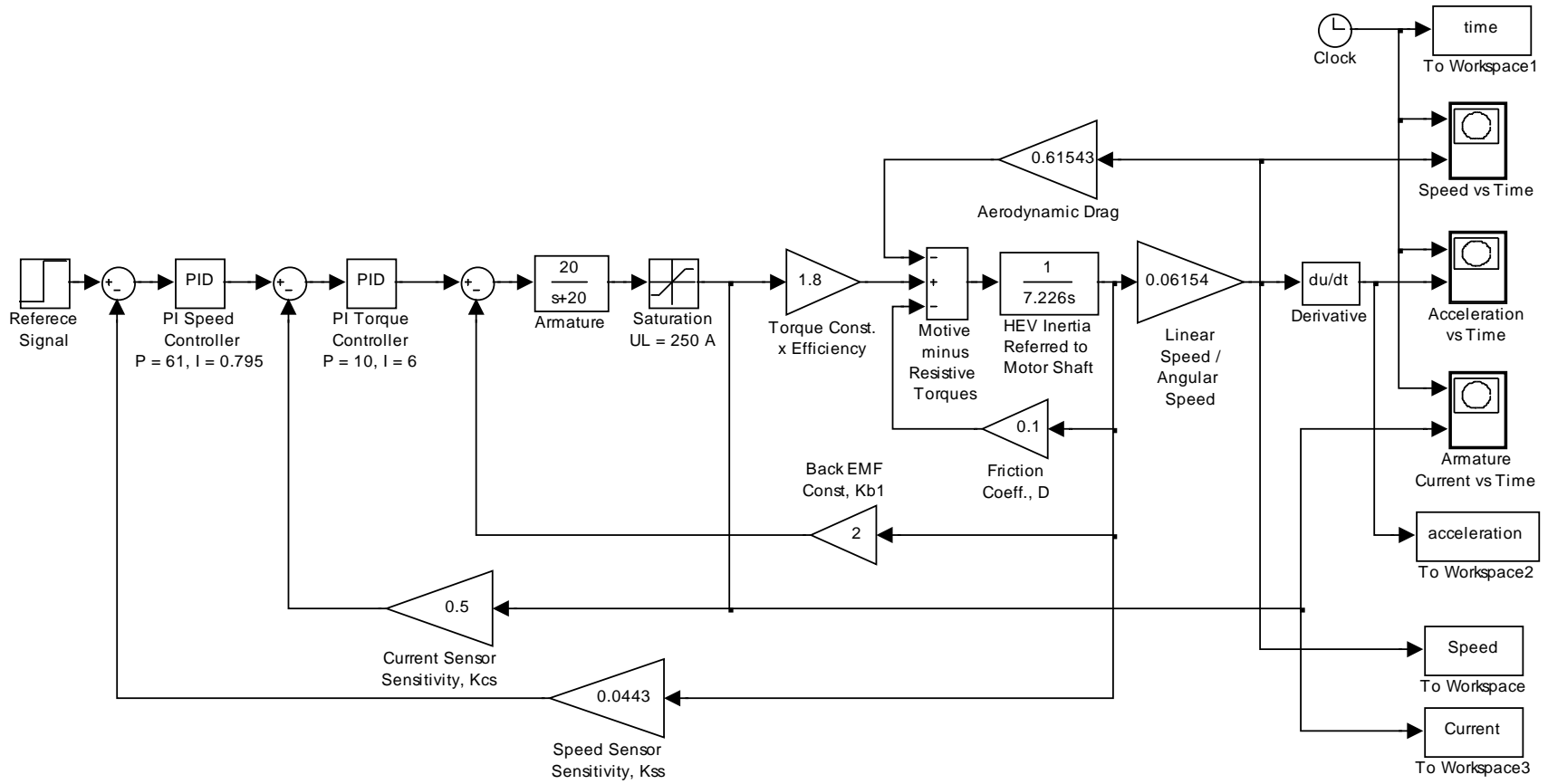

As a result of that simulation, the following figures were obtained:

1. Change in Motor Armature Current in Response to a Speed Change Command;
2. Change in Car Acceleration in Response to a Speed Change Command;
3. Change in Car Speed in Response to a 4-V Reference Input Step.

Based on these graphs, the following observations may be made:

- a. The armature current rises very fast to 250 amps; sustains at that level for 0.7 seconds,

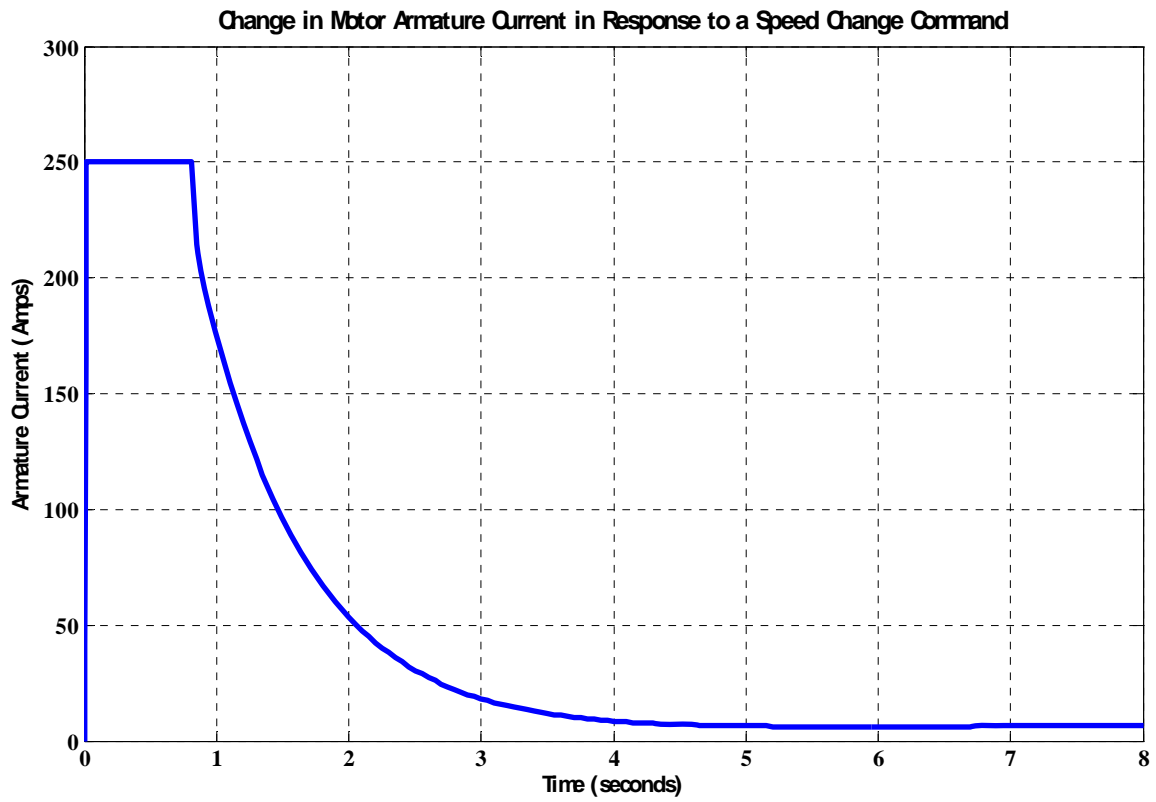



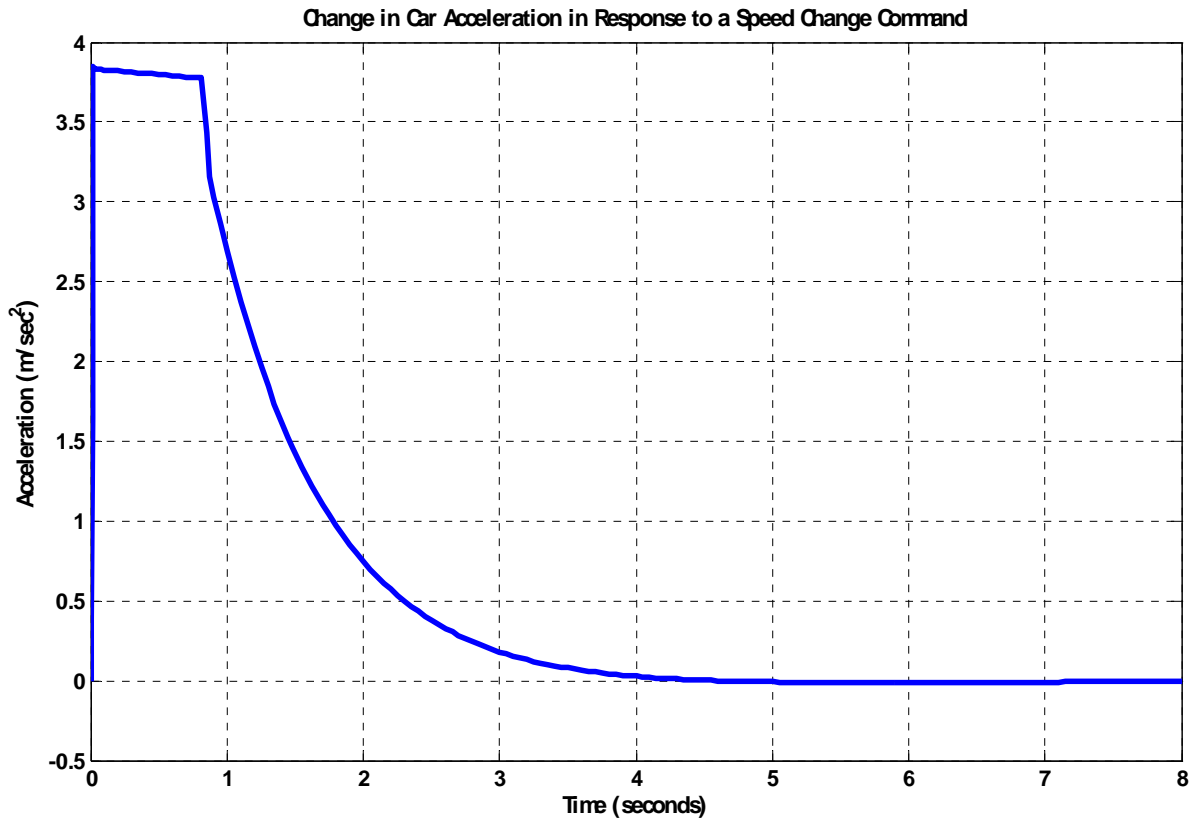

then drops down exponentially (in about 4 seconds) to 7.0 amps  $\pm$  5%.

- b. Car acceleration also rises very fast to 3.833 m/s<sup>2</sup>, drops down slightly (to 3.75 m/s<sup>2</sup>) in the first 0.7 seconds, then drops down exponentially (in about 4.3 seconds) to 0.
- c. With a saturation element (set to a limit of 250 A) placed at the output of the motor armature, the step response obtained for the change in car speed exhibits realistic values of the rise and settling times (1.75 and 2.8 seconds, respectively), whereas the steady-state error in car speed remains equal to zero (the final car speed = 5.556 m/sec) and the steady-state error in car acceleration remains below 2% ( $P = K_1 = 61 \geq 48.83$ ).

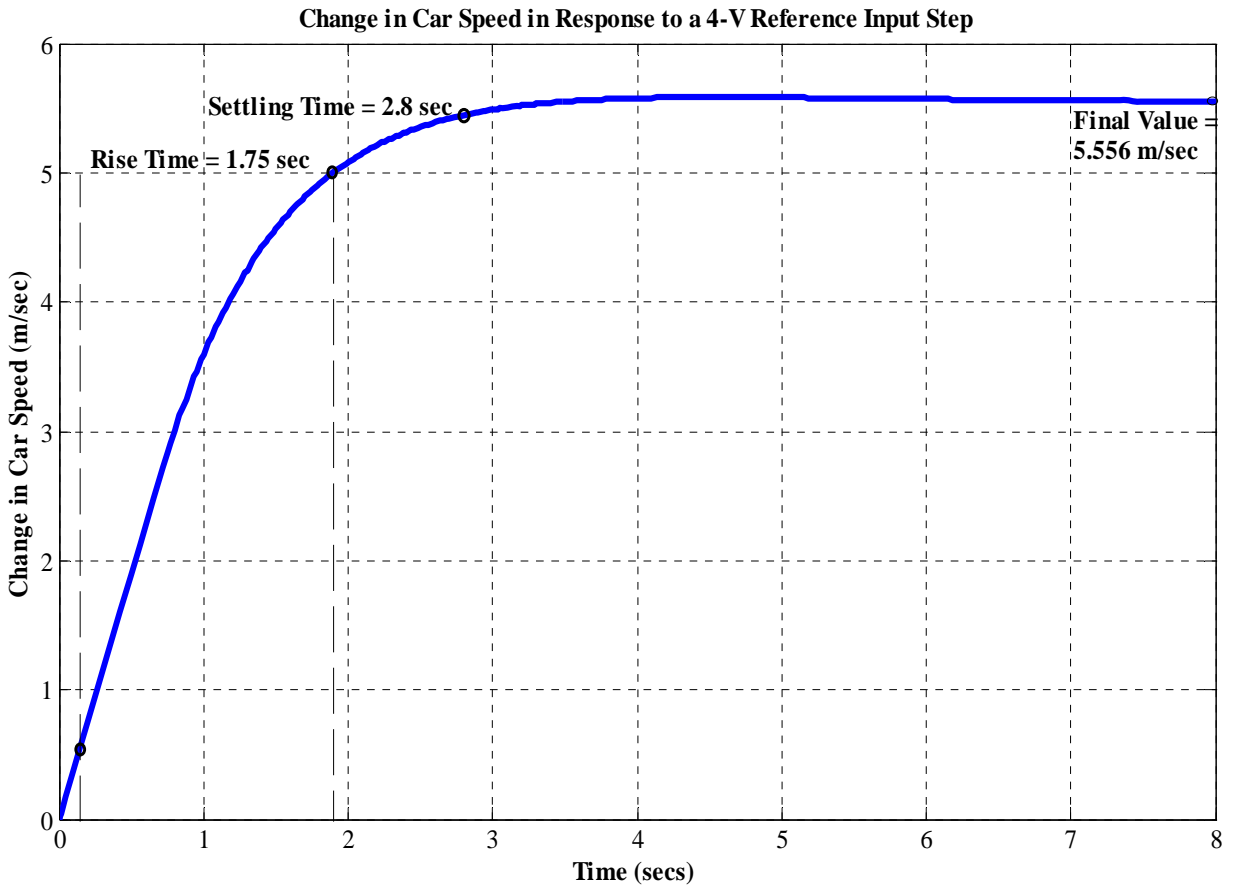

# T E N

## Frequency Response Techniques

### SOLUTION TO CASE STUDY CHALLENGE

#### Antenna Control: Stability Design and Transient Performance

First find the forward transfer function,  $G(s)$ .

Pot:

$$K_1 = \frac{10}{\pi} = 3.18$$

Preamp:

$$K$$

Power amp:

$$G_1(s) = \frac{100}{s(s+100)}$$

Motor and load:

$$J = 0.05 + 5 \left(\frac{1}{5}\right)^2 = 0.25 ; D = 0.01 + 3 \left(\frac{1}{5}\right)^2 = 0.13 ; \frac{K_t}{R_a} = \frac{1}{5} ; K_b = 1.$$

Therefore,

$$G_m(s) = \frac{\theta_m(s)}{E_a(s)} = \frac{\frac{K_t}{R_a J}}{s(s + \frac{1}{J}(D + \frac{K_t K_b}{R_a}))} = \frac{0.8}{s(s+1.32)} .$$

Gears:

$$K_2 = \frac{50}{250} = \frac{1}{5}$$

Therefore,

$$G(s) = K_1 K G_1(s) G_m(s) K_2 = \frac{50.88K}{s(s+1.32)(s+100)}$$

Plotting the Bode plots for  $K = 1$ ,

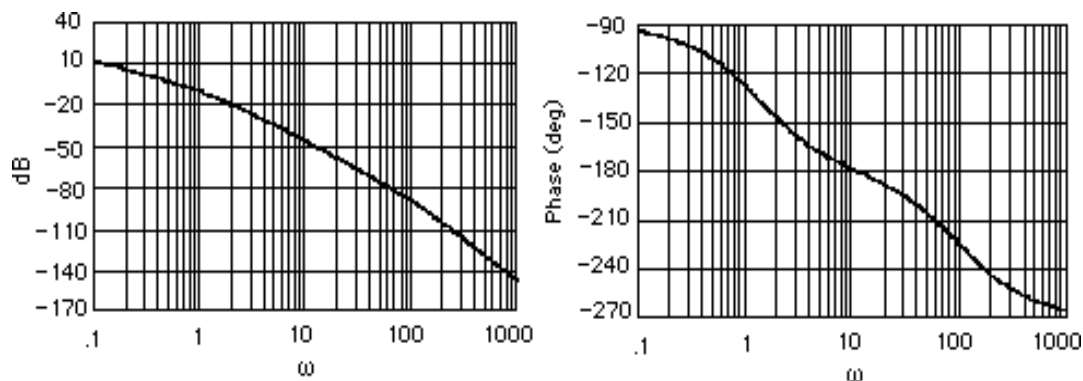

a. Phase is  $180^\circ$  at  $\omega = 11.5$  rad/s. At this frequency the gain is  $-48.41$  dB, or  $K = 263.36$ . Therefore, for stability,  $0 < K < 263.36$ .

b. If  $K = 3$ , the magnitude curve will be  $9.54$  dB higher and go through zero dB at  $\omega = 0.94$  rad/s. At this frequency, the phase response is  $-125.99^\circ$ . Thus, the phase margin is  $180^\circ - 125.99^\circ = 54.01^\circ$ . Using Eq. (10.73),  $\zeta = 0.528$ . Eq. (4.38) yields  $\%OS = 14.18\%$ .

c.

**Program:**

```
numga=50.88;
denga=poly([0 -1.32 -100]);
'Ga(s)'
Ga=tf(numga,denga);
Gazpk=zpk(Ga)
'(a)'
bode(Ga)
title('Bode Plot at Gain of 50.88')
pause
[Gm,Pm,Wcp,Wcg]=margin(Ga);
'Gain for Stability'
Gm
pause
'(b)'
numgb=50.88*3;
dengb=denga;
'Gb(s)'
Gb=tf(numgb,dengb);
Gbzpk=zpk(Gb)
bode(Gb)
title('Bode Plot at Gain of 3*50.88')
[Gm,Pm,Wcp,Wcg]=margin(Gb);
'Phase Margin'
Pm
for z=0:.01:1
Pme=atan(2*z/(sqrt(-2*z^2+sqrt(1+4*z^4))))*(180/pi);
if Pm-Pme<=0;
break
end
end
z
percent=exp(-z*pi/sqrt(1-z^2))*100
```

**Computer response:**

ans =

Ga(s)

Zero/pole/gain:  
50.88

-----  
s (s+100) (s+1.32)

ans =

(a)

ans =

Gain for Stability

Gm =

262.8585

ans =

(b)

ans =

Gb(s)

Zero/pole/gain:  
152.64

-----  
s (s+100) (s+1.32)

ans =

Phase Margin

Pm =

53.9644

z =

0.5300

percent =

14.0366

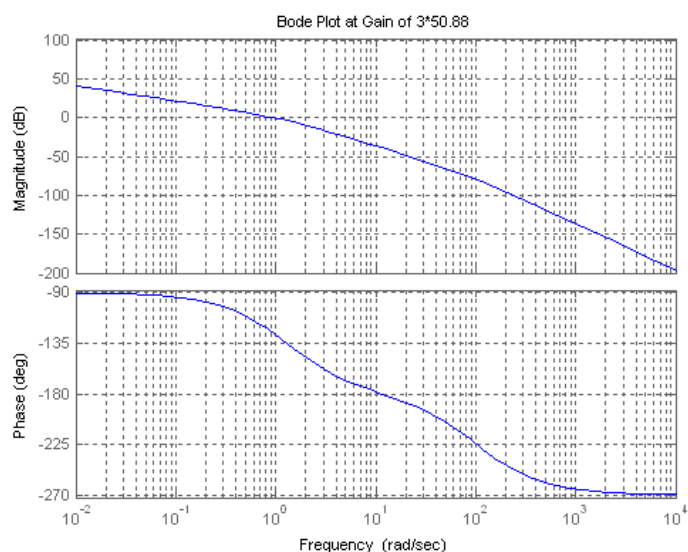
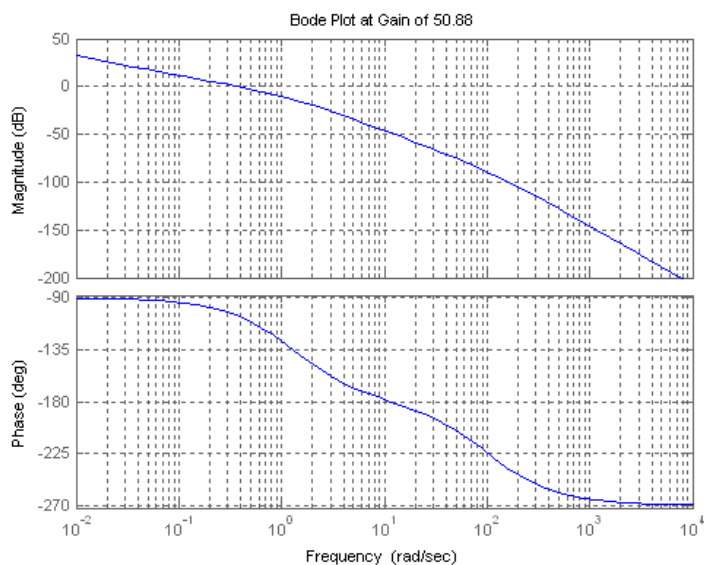

## ANSWERS TO REVIEW QUESTIONS

**1. a.** Transfer functions can be modeled easily from physical data; **b.** Steady-state error requirements can be considered easily along with the design for transient response; **c.** Settles ambiguities when sketching root locus; (d) Valuable tool for analysis and design of nonlinear systems.

**2.** A sinusoidal input is applied to a system. The sinusoidal output's magnitude and phase angle is measured in the steady-state. The ratio of the output magnitude divided by the input magnitude is the magnitude response at the applied frequency. The difference between the output phase angle and the input phase angle is the phase response at the applied frequency. If the magnitude and phase response are plotted over a range of different frequencies, the result would be the frequency response for the system.

3. Separate magnitude and phase curves; polar plot
4. If the transfer function of the system is  $G(s)$ , let  $s=j\omega$ . The resulting complex number's magnitude is the magnitude response, while the resulting complex number's angle is the phase response.
5. Bode plots are asymptotic approximations to the frequency response displayed as separate magnitude and phase plots, where the magnitude and frequency are plotted in dB.
6. Negative 6 dB/octave which is the same as 20 dB/decade
7. Negative 24 dB/octave or 80 dB/decade
8. Negative 12 dB/octave or 40 dB/decade
9. Zero degrees until 0.2; a negative slope of  $45^\circ$ /decade from a frequency of 0.2 until 20; a constant  $-90^\circ$  phase from a frequency of 20 until  $\infty$
10. Second-order systems require a correction near the natural frequency due to the peaking of the curve for different values of damping ratio. Without the correction the accuracy is in question.
11. Each pole yields a maximum difference of 3.01 dB at the break frequency. Thus for a pole of multiplicity three, the difference would be  $3 \times 3.01$  or 9.03 dB at the break frequency, - 4.
12.  $Z = P - N$ , where  $Z = \#$  of closed-loop poles in the right-half plane,  $P = \#$  of open-loop poles in the right-half plane, and  $N = \#$  of counter-clockwise encirclements of -1 made by the mapping.
13. Whether a system is stable or not since the Nyquist criterion tells us how many rhp the system has
14. A Nyquist diagram, typically, is a mapping, through a function, of a semicircle that encloses the right half plane.
15. Part of the Nyquist diagram is a polar frequency response plot since the mapping includes the positive  $j\omega$  axis.
16. The contour must bypass them with a small semicircle.
17. We need only map the positive imaginary axis and then determine that the gain is less than unity when the phase angle is  $180^\circ$ .
18. We need only map the positive imaginary axis and then determine that the gain is greater than unity when the phase angle is  $180^\circ$ .
19. The amount of additional open-loop gain, expressed in dB and measured at  $180^\circ$  of phase shift, required to make a closed-loop system unstable.
20. The phase margin is the amount of additional open-loop phase shift,  $\Phi_M$ , required at unity gain to make the closed-loop system unstable.
21. Transient response can be obtained from (1) the closed-loop frequency response peak, (2) phase margin
22. **a.** Find  $T(j\omega) = G(j\omega) / [1 + G(j\omega)H(j\omega)]$  and plot in polar form or separate magnitude and phase plots. **b.** Superimpose  $G(j\omega)H(j\omega)$  over the M and N circles and plot. **c.** Superimpose  $G(j\omega)H(j\omega)$  over the Nichols chart and plot.

23. For Type zero:  $K_p$  = low frequency gain; For Type 1:  $K_v$  = frequency value at the intersection of the initial slope with the frequency axis; For Type 2:  $K_a$  = square root of the frequency value at the intersection of the initial slope with the frequency axis.

24. No change at all

25. A straight line of negative slope,  $\omega T$ , where  $T$  is the time delay

26. When the magnitude response is flat and the phase response is flat at  $0^\circ$ .

## SOLUTIONS TO PROBLEMS

1.

a.

$$G(s) = \frac{1}{s(s+2)(s+4)}; \quad G(j\omega) = \frac{1}{-6\omega^2 + i(8\omega - \omega^3)}$$

$$M(\omega) = \frac{1}{\sqrt{(8\omega - \omega^3)^2 + (6\omega^2)^2}}; \quad \phi(\omega) = -\left(\pi + \arctan\left[\frac{8 - \omega^2}{-6\omega}\right]\right)$$

b.

$$G(s) = \frac{(s+5)}{(s+2)(s+4)}; \quad G(j\omega) = \frac{(\omega^2 + 40) - i(\omega^2 + 22)\omega}{\omega^4 + 20\omega^2 + 64}$$

$$M(\omega) = \frac{\sqrt{(\omega^2 + 40)^2 + \omega^2(\omega^2 + 22)^2}}{\omega^4 + 20\omega^2 + 64}; \quad \phi(\omega) = \arctan\left(\frac{-(\omega^2 + 22)\omega}{\omega^2 + 40}\right)$$

c.

$$G(s) = \frac{(s+3)(s+5)}{s(s+4)(s+2)}; \quad G(j\omega) = \frac{-2\omega(\omega^2 + 13) - i(\omega^4 + 25\omega^2 + 120)}{\omega^5 + 20\omega^3 + 64\omega}$$

$$M(\omega) = \frac{\sqrt{(2\omega[\omega^2 + 13])^2 + (\omega^4 + 25\omega^2 + 120)^2}}{\omega^5 + 20\omega^3 + 64\omega}; \quad \phi(\omega) = \pi + \arctan\left(\frac{\omega^4 + 25\omega^2 + 120}{2\omega[\omega^2 + 13]}\right)$$

2.

a.

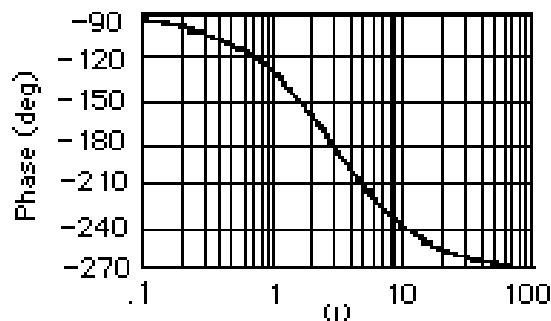
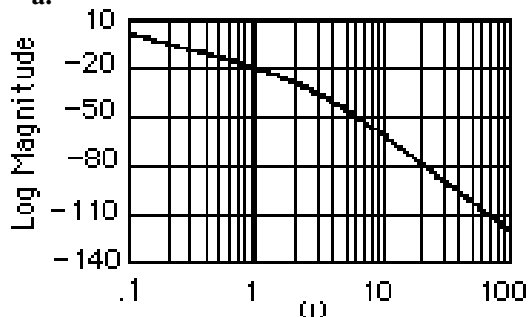



b.

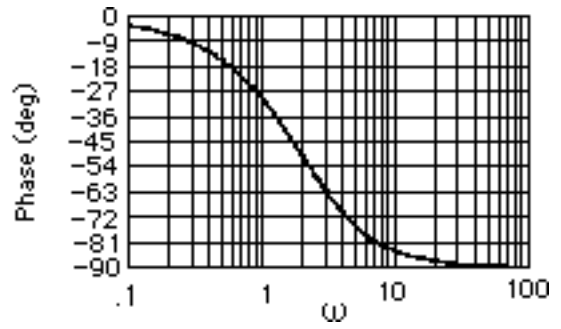
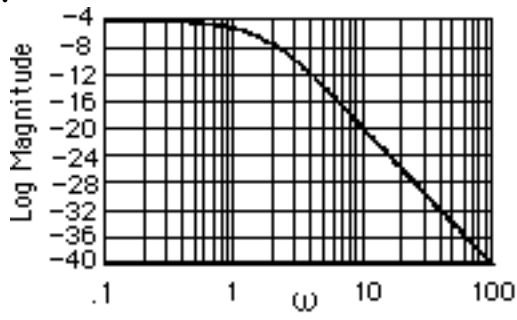

c.

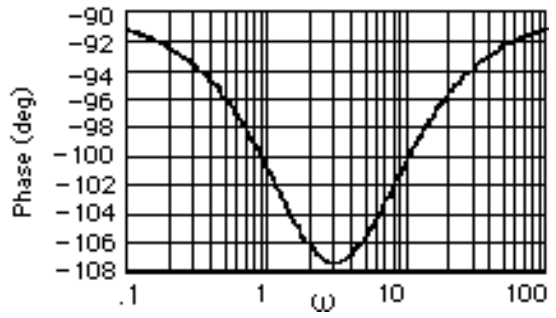
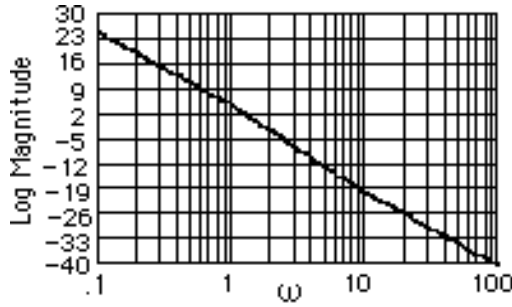

3.

a.

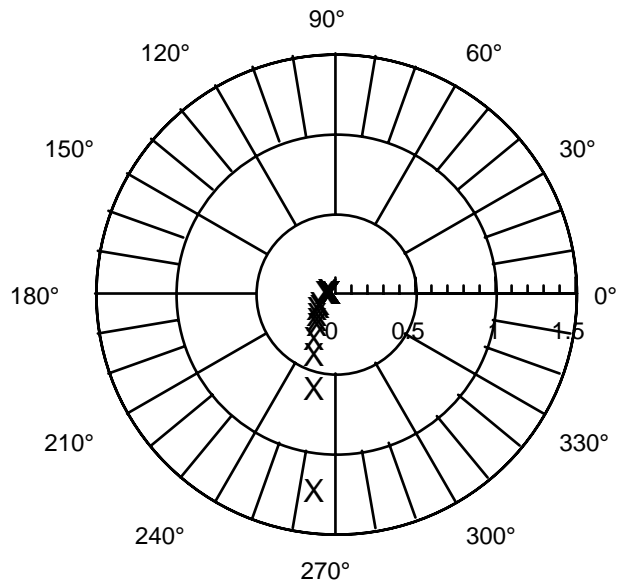

b.

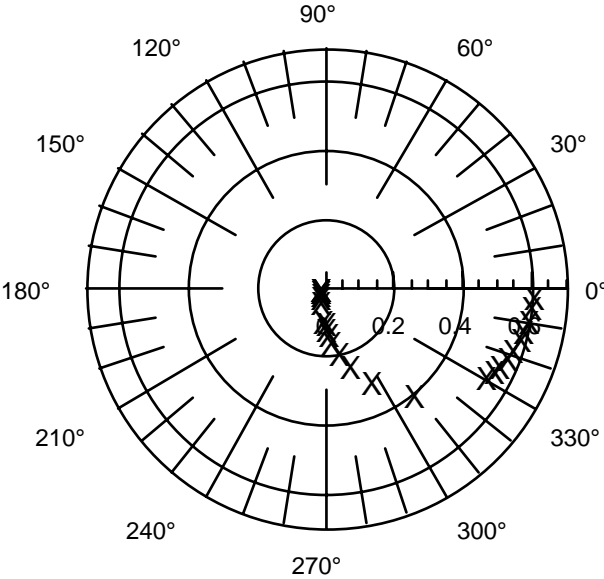

c.

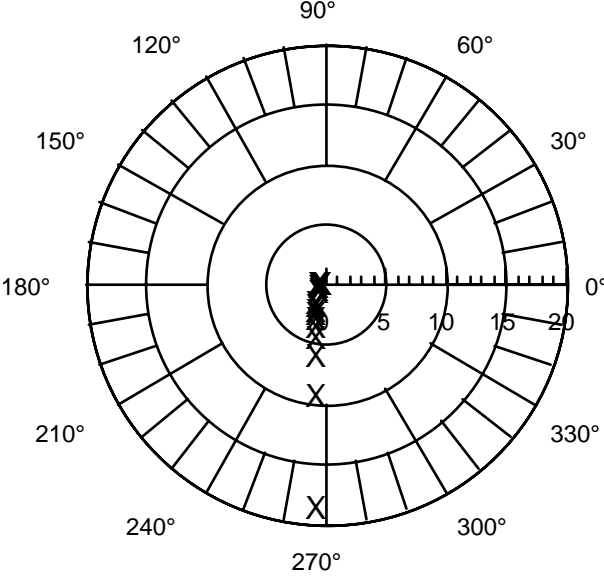

4.

a.

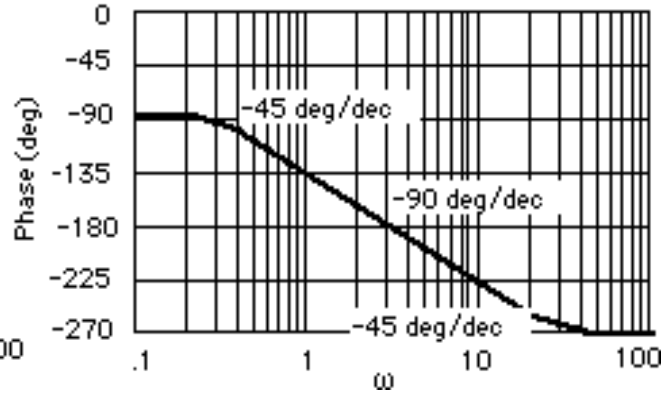
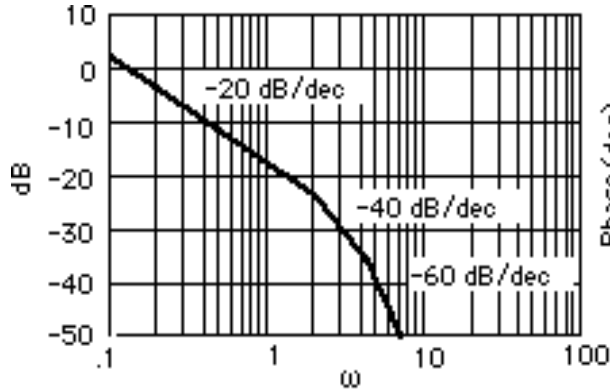

b.

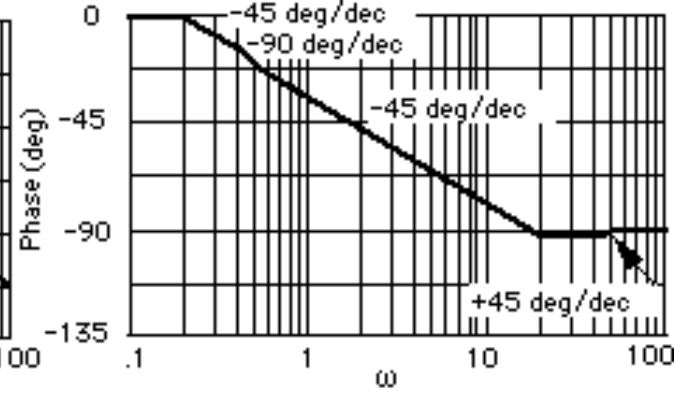
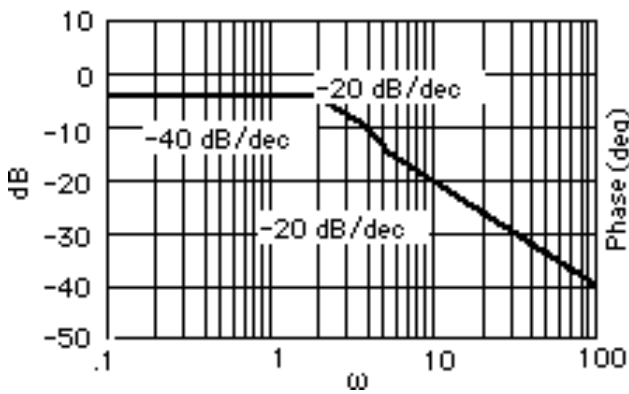

c.

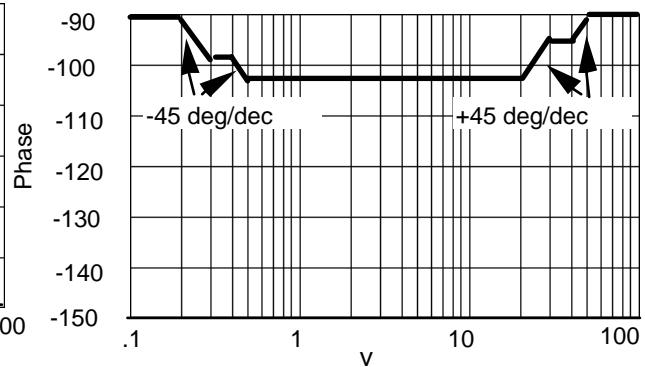
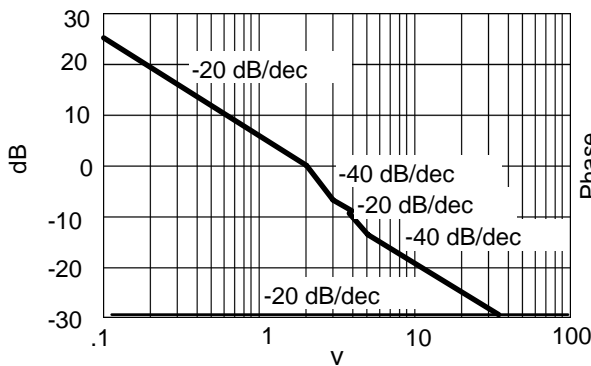

5.  
a. System 1

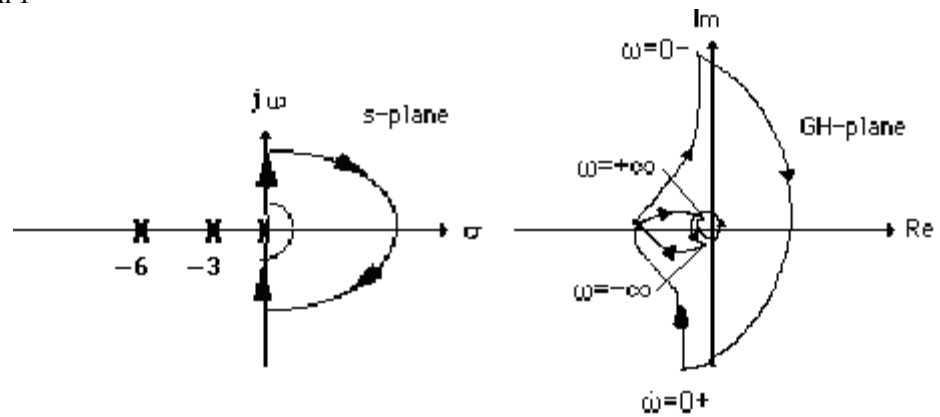

- b. System 2

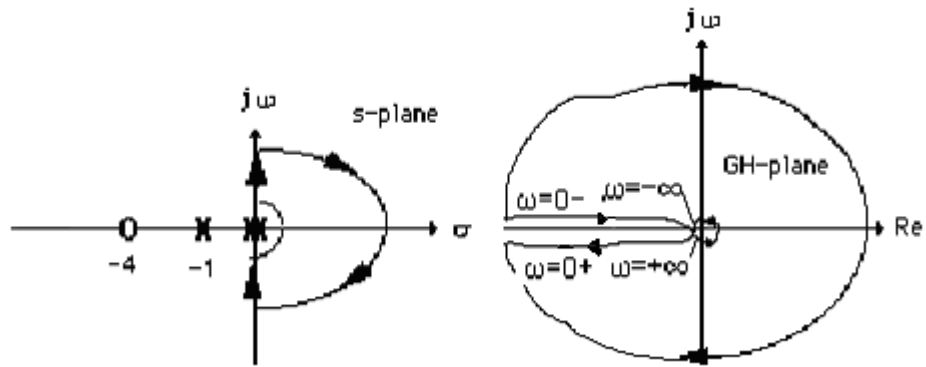

- c. System 3

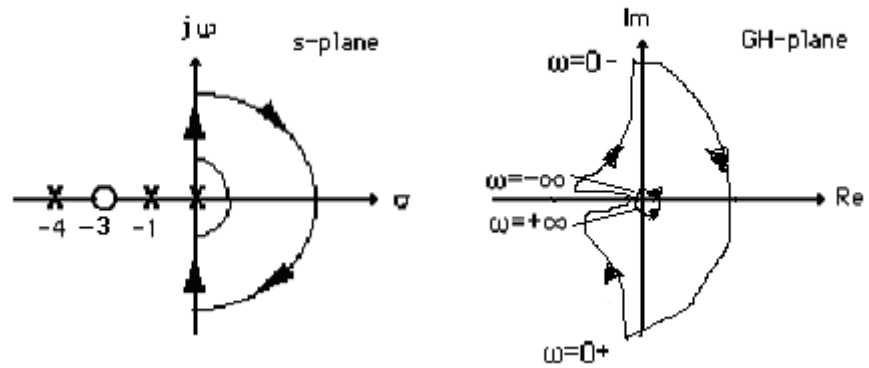

d.

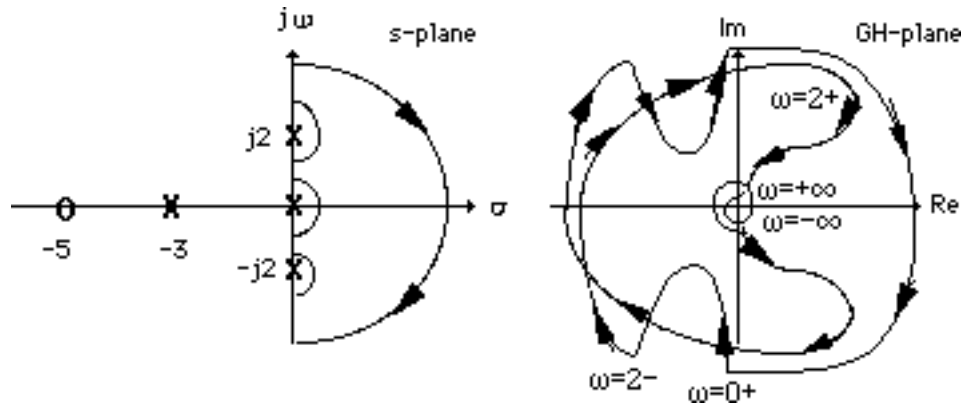

6.

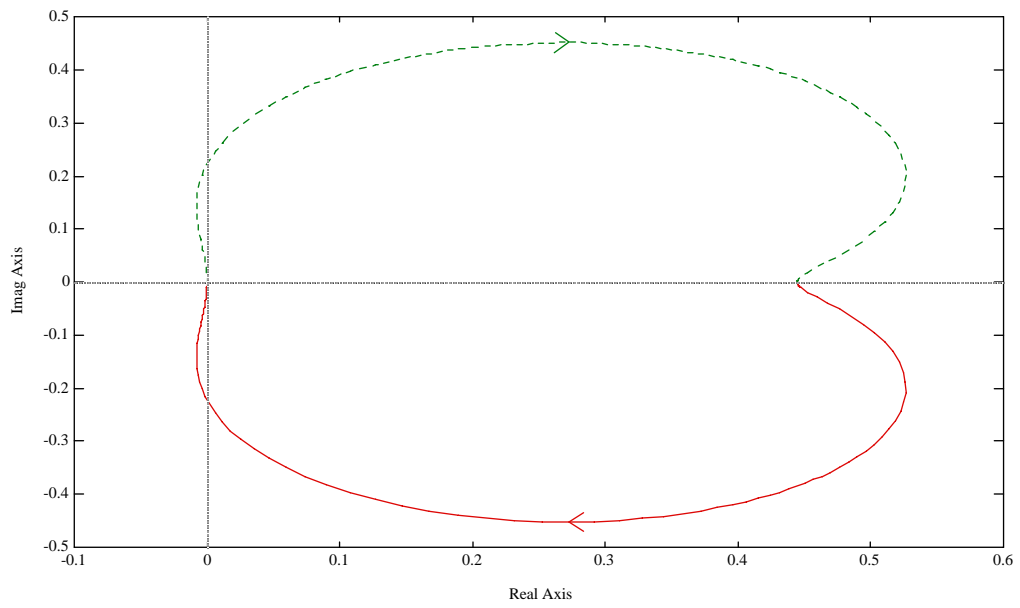

7.

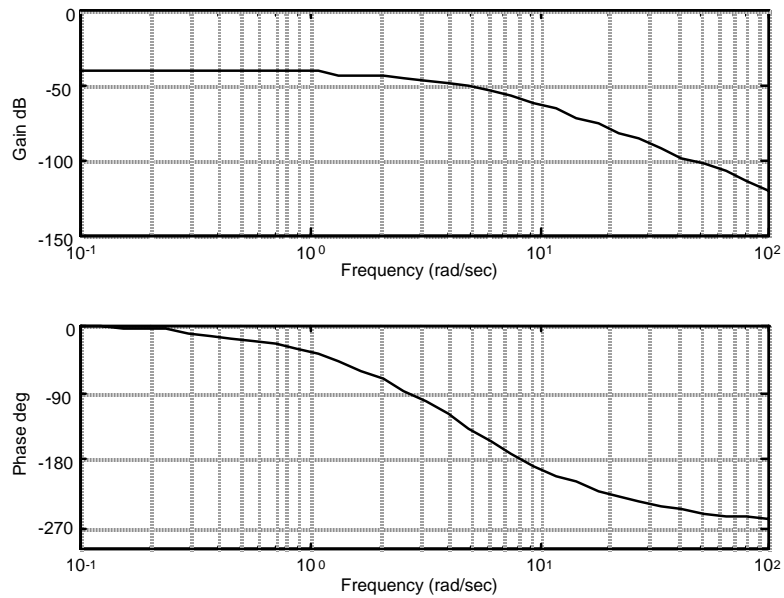

8.

**Program:**

```

numg=[1 5];
deng=conv([1 6 100],[1 4 25]);
G=tf(numg,deng);
'G(s)'
Gzpk=zpk(G)
nyquist(G)
axis([-3e-3,4e-3,-5e-3,5e-3])
w=0:0.1:100;
[re,im]=nyquist(G,w);
for i=1:1:length(w)
M(i)=abs(re(i)+j*im(i));
A(i)=atan2(im(i),re(i))*(180/pi);
if 180-abs(A(i))<=1;
re(i);
im(i);
K=1/abs(re(i));
fprintf('\nw = %g',w(i))
fprintf(' , Re = %g',re(i))
fprintf(' , Im = %g',im(i))
fprintf(' , M = %g',M(i))
fprintf(' , Angle = %g',A(i))
fprintf(' , K = %g',K)
Gm=20*log10(1/M(i));
fprintf(' , Gm = %g',Gm)
break
end
end
end

```

**Computer response:**

ans =

G(s)

Zero/pole/gain:  
(s+5)

$$(s^2 + 4s + 25) (s^2 + 6s + 100)$$

w = 10.1, Re = -0.00213722, Im = 2.07242e-005, M = 0.00213732, Angle = 179.444, K = 467.898, Gm = 53.4026

ans =

G(s)

Zero/pole/gain:

$$(s+5)$$

$$(s^2 + 4s + 25) (s^2 + 6s + 100)$$

w = 10.1, Re = -0.00213722, Im = 2.07242e-005, M = 0.00213732, Angle = 179.444, K = 467.898, Gm = 53.4026

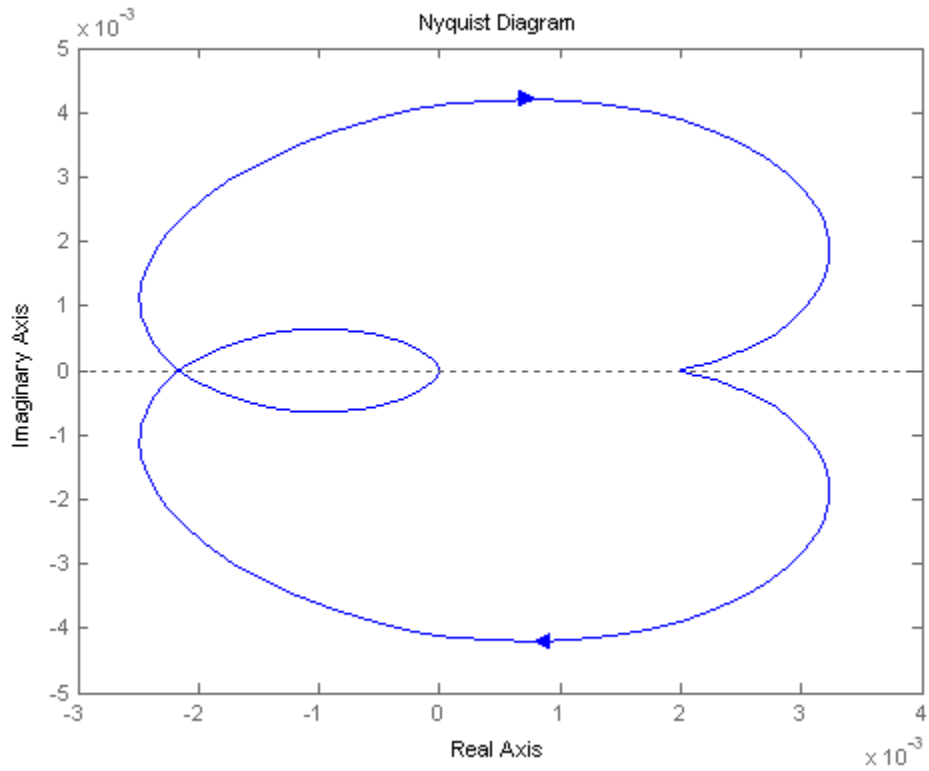

9.

a. Since the real-axis crossing is at -0.3086, P = 0, N = 0. Therefore Z = P - N = 0. System is stable.

Derivation of real-axis crossing:

$$G(j\omega) = \frac{50}{s(s+3)(s+6)} \Big|_{s=j\omega} = \frac{50 \left[ -9\omega^2 - j\omega(18 - \omega^2) \right]}{81\omega^4 + (18\omega - \omega^3)}$$

Thus, the imaginary part = 0 at  $\omega = \sqrt{18}$ . Substituting this frequency into  $G(j\omega)$ , the real part is evaluated to be -0.3086.

**b.**  $P = 0, N = -2$ . Therefore  $Z = P - N = 2$ . System is unstable.

**c.**  $P = 0, N = 0$ . Therefore  $Z = P - N = 0$ . System is stable

**d.**  $P = 0, N = -2$ . Therefore  $Z = P - N = 2$ . System is unstable.

**10.** System 1: For  $K = 1$ ,

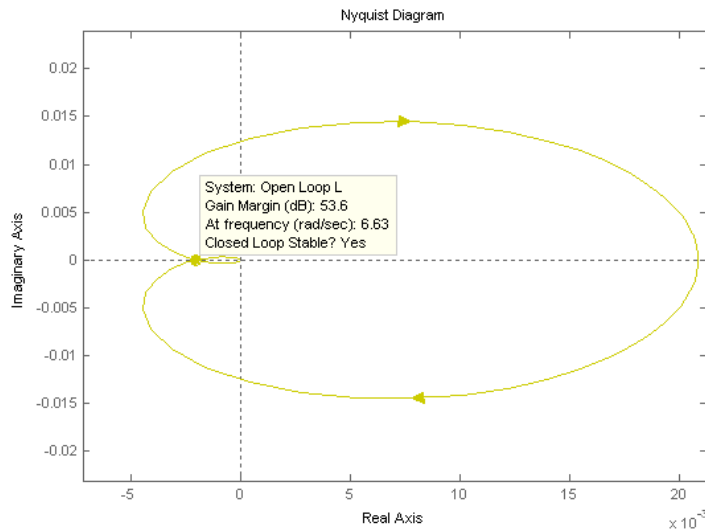

The Nyquist diagram intersects the real axis at -0.0021. Thus  $K$  can be increased to 478.63 before there are encirclements of -1. There are no poles encircled by the contour. Thus  $P = 0$ . Hence,  $Z = P - N, Z = 0 + 0$  if  $K < 478.63$ ;  $Z = 0 - (-2)$  if  $K > 478.63$ . Therefore stability if  $0 < K < 478.63$ .

System 2: For  $K = 1$ ,

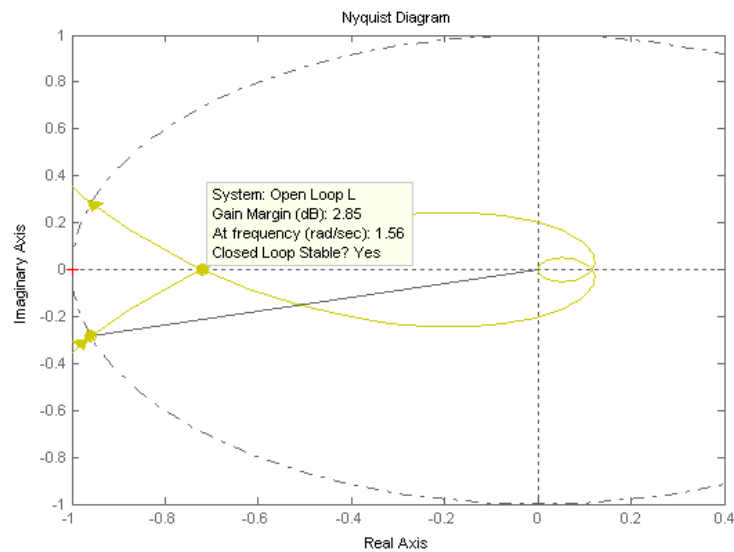



The Nyquist diagram intersects the real axis at  $-0.720$ . Thus  $K$  can be increased to  $1.39$  before there are encirclements of  $-1$ . There are no poles encircled by the contour. Thus  $P = 0$ . Hence,  $Z = P - N$ ,  $Z = 0 + 0$  if  $K < 1.39$ ;  $Z = 0 - (-2)$  if  $K > 1.39$ . Therefore stability if  $0 < K < 1.39$ .

System 3: For  $K = 1$ ,

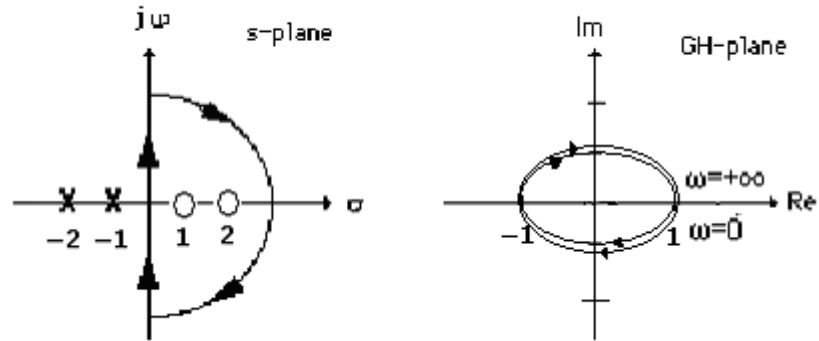

Stable if  $0 < K < 1$ .

11.

Note: All results for this problem are based upon a non-asymptotic frequency response.

**System 1:** Plotting Bode plots for  $K = 1$  yields the following Bode plot,

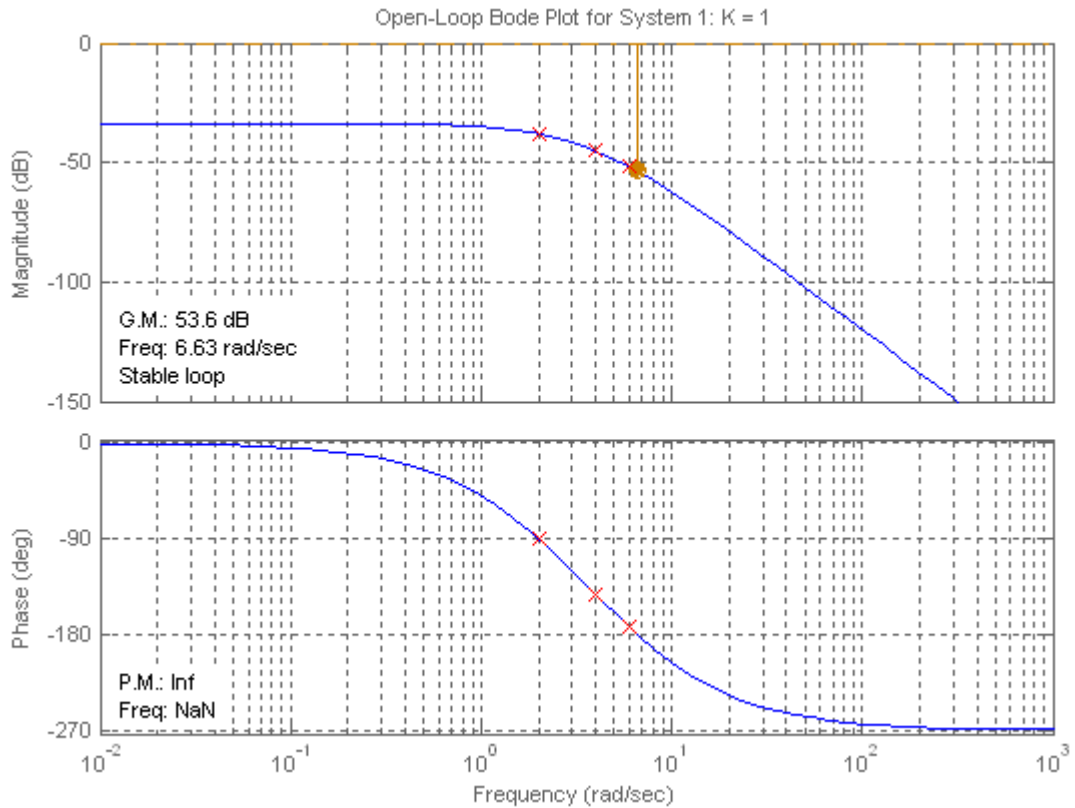

$K = 1000$ :

For  $K = 1$ , phase response is  $180^\circ$  at  $\omega = 6.63$  rad/s. Magnitude response is  $-53.6$  dB at this frequency.

For  $K = 1000$ , magnitude curve is raised by  $60$  dB yielding  $+6.4$  dB at  $6.63$  rad/s. Thus, the gain margin is

$-6.4$  dB.

Phase margin: Raising the magnitude curve by  $60$  dB yields  $0$  dB at  $9.07$  rad/s, where the phase curve is  $200.3^\circ$ . Hence, the phase margin is  $180^\circ - 200.3^\circ = -20.3^\circ$ .

$K = 100$ :

For  $K = 1$ , phase response is  $180^\circ$  at  $\omega = 6.63$  rad/s. Magnitude response is  $-53.6$  dB at this frequency.

For  $K = 100$ , magnitude curve is raised by  $40$  dB yielding  $-13.6$  dB at  $6.63$  rad/s. Thus, the gain margin is  $13.6$  dB.

Phase margin: Raising the magnitude curve by  $40$  dB yields  $0$  dB at  $2.54$  rad/s, where the phase curve is  $107.3^\circ$ . Hence, the phase margin is  $180^\circ - 107.3^\circ = 72.7^\circ$ .

$K = 0.1$ :

For  $K = 1$ , phase response is  $180^\circ$  at  $\omega = 6.63$  rad/s. Magnitude response is  $-53.6$  dB at this frequency.

For  $K = 0.1$ , magnitude curve is lowered by  $20$  dB yielding  $-73.6$  dB at  $6.63$  rad/s. Thus, the gain margin is  $73.6$  dB.

**System 2:** Plotting Bode plots for  $K = 1$  yields

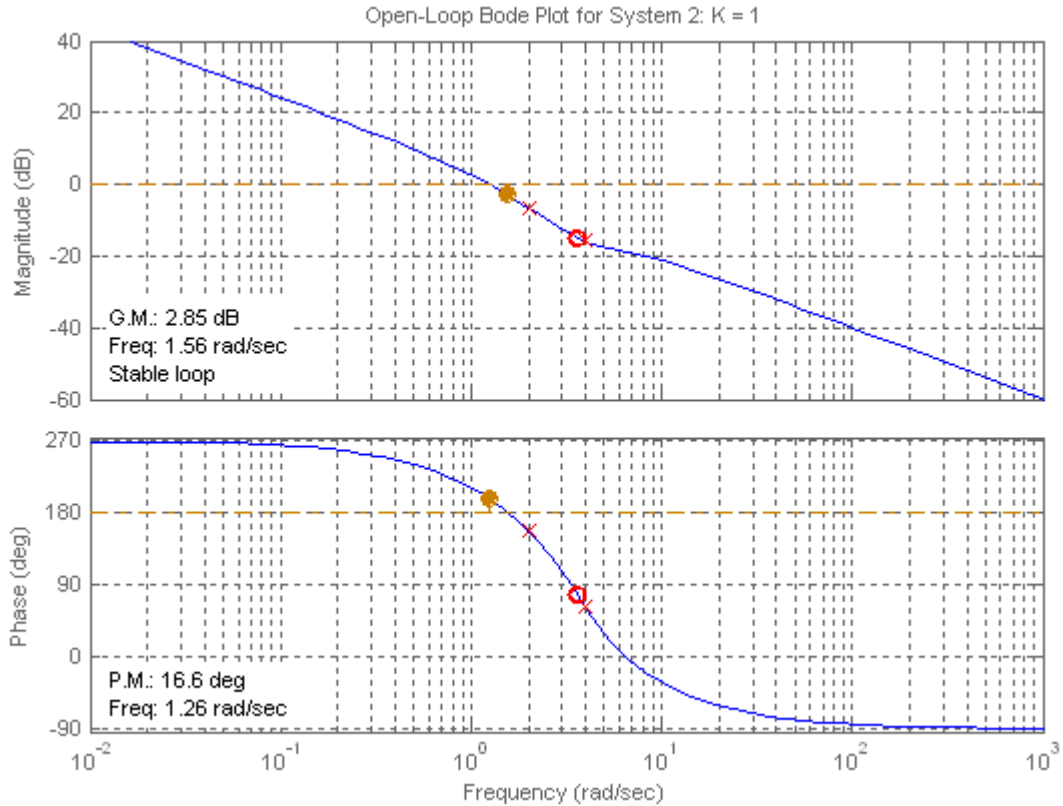

K = 1000:

For K = 1, phase response is  $180^\circ$  at  $\omega = 1.56$  rad/s. Magnitude response is -2.85 dB at this frequency.

For K = 1000, magnitude curve is raised by 60 dB yielding + 57.15 dB at 1.56 rad/s. Thus, the gain margin is

- 57.15 dB.

Phase margin: Raising the magnitude curve by 54 dB yields 0 dB at 500 rad/s, where the phase curve is  $-91.03^\circ$ . Hence, the phase margin is  $180^\circ - 91.03^\circ = 88.97^\circ$ .

K = 100:

For K = 1, phase response is  $180^\circ$  at  $\omega = 1.56$  rad/s. Magnitude response is -2.85 dB at this frequency.

For K = 100, magnitude curve is raised by 40 dB yielding + 37.15 dB at 1.56 rad/s. Thus, the gain margin is

- 37.15 dB.

Phase margin: Raising the magnitude curve by 40 dB yields 0 dB at 99.8 rad/s, where the phase curve is  $-84.3^\circ$ . Hence, the phase margin is  $180^\circ - 84.3^\circ = 95.7^\circ$ .

K = 0.1:

For K = 1, phase response is  $180^\circ$  at  $\omega = 1.56$  rad/s. Magnitude response is -2.85 dB at this frequency.

For K = 0.1, magnitude curve is lowered by 20 dB yielding - 22.85 dB at 1.56 rad/s. Thus, the gain

margin is

- 22.85 dB.

Phase margin: Lowering the magnitude curve by 20 dB yields 0 dB at 0.162 rad/s, where the phase curve is  $-99.8^\circ$ . Hence, the phase margin is  $180^\circ - 99.86^\circ = 80.2^\circ$ .

**System 3:** Plotting Bode plots for  $K = 1$  yields

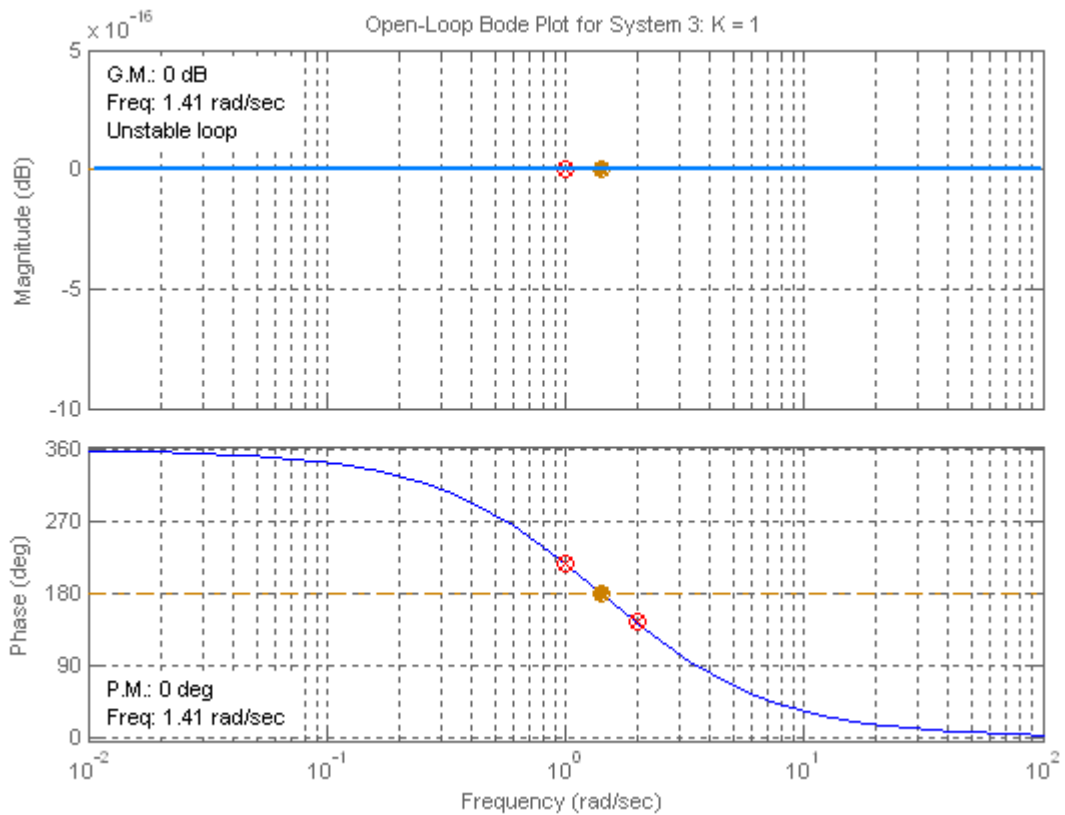

$K = 1000$ :

For  $K = 1$ , phase response is  $180^\circ$  at  $\omega = 1.41$  rad/s. Magnitude response is 0 dB at this frequency.

For  $K = 1000$ , magnitude curve is raised by 60 dB yielding 60 dB at 1.41 rad/s. Thus, the gain margin is - 60 dB.

Phase margin: Raising the magnitude curve by 60 dB yields no frequency where the magnitude curve is 0 dB. Hence, the phase margin is infinite.

$K = 100$ :

For  $K = 1$ , phase response is  $180^\circ$  at  $\omega = 1.41$  rad/s. Magnitude response is 0 dB at this frequency.

For  $K = 100$ , magnitude curve is raised by 40 dB yielding 40 dB at 1.41 rad/s. Thus, the gain margin is - 40 dB.

Phase margin: Raising the magnitude curve by 40 dB yields no frequency where the magnitude curve is 0 dB. Hence, the phase margin is infinite.

$K = 0.1$ :

For  $K = 1$ , phase response is  $180^\circ$  at  $\omega = 1.41$  rad/s. Magnitude response is 0 dB at this frequency.

For  $K = 0.1$ , magnitude curve is lowered by 20 dB yielding -20 dB at 1.41 rad/s. Thus, the gain margin is 20 dB.

Phase margin: Lowering the magnitude curve by 20 dB yields no frequency where the magnitude curve is 0 dB. Hence, the phase margin is infinite.

## 12.

### Program:

```
%Enter G(s)*****
numg=1;
deng=poly([0 -3 -12]);
'G(s)'
G=tf(numg,deng)
w=0.01:0.1:100;
%Enter K *****
K=input('Type gain, K ');
bode(K*G,w)
pause
[M,P]=bode(K*G,w);
%Calculate Gain Margin*****
for i=1:length(P);
if P(i)<=-180;
fprintf('\nGain K = %g',K)
fprintf(' , Frequency(180 deg) = %g',w(i))
fprintf(' , Magnitude = %g',M(i))
fprintf(' , Magnitude (dB) = %g',20*log10(M(i)))
fprintf(' , Phase = %g',P(i))
Gm=20*log10(1/M(i));
fprintf(' , Gain Margin (dB) = %g',Gm)
break
end
end
%Calculate Phase Margin*****
for i=1:length(M);
if M(i)<=1;
fprintf('\nGain K = %g',K)
fprintf(' , Frequency (0 dB) = %g',w(i))
fprintf(' , Magnitude = %g',M(i))
fprintf(' , Magnitude (dB) = %g',20*log10(M(i)))
fprintf(' , Phase = %g',P(i))
Pm=180+P(i);;
fprintf(' , Phase Margin = %g',Pm)
break
end
end

'Alternate program using MATLAB margin function:'

clear
clf
%Bode Plot and Find Points
%Enter G(s)*****
numg=1;
deng=poly([0 -3 -12]);
'G(s)'
G=tf(numg,deng)
w=0.01:0.1:100;
```

## 10-20 Chapter 10: Frequency Response Methods

```
%Enter K *****
K=input('Type gain, K ');
bode(K*G,w)
[Gm,Pm,Wcp,Wcg]=margin(K*G)
'Gm(dB)'
20*log10(Gm)
```

### Computer response:

ans =

G(s)

Transfer function:

$$\frac{1}{s^3 + 15s^2 + 36s}$$

Type gain, K 40

Gain K = 40, Frequency(180 deg) = 6.01, Magnitude = 0.0738277, Magnitude (dB) = -22.6356, Phase = -180.076, Gain Margin (dB) = 22.6356  
Gain K = 40, Frequency (0 dB) = 1.11, Magnitude = 0.93481, Magnitude (dB) = -0.585534, Phase = -115.589, Phase Margin = 64.4107

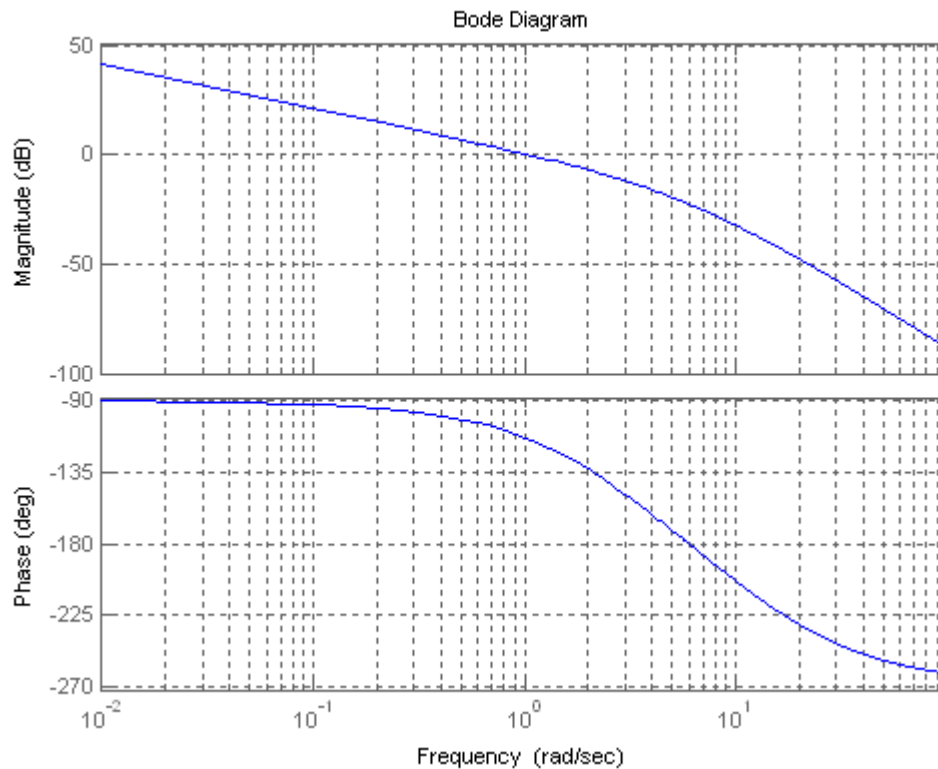

Alternate program using MATLAB margin function:

ans =

G(s)

Transfer function:

1

-----  
s^3 + 15 s^2 + 36 s

Type gain, K 40

Gm =

13.5000

Pm =

65.8119

Wcp =

6

Wcg =

1.0453

ans =

Gm(dB)

ans =

22.6067

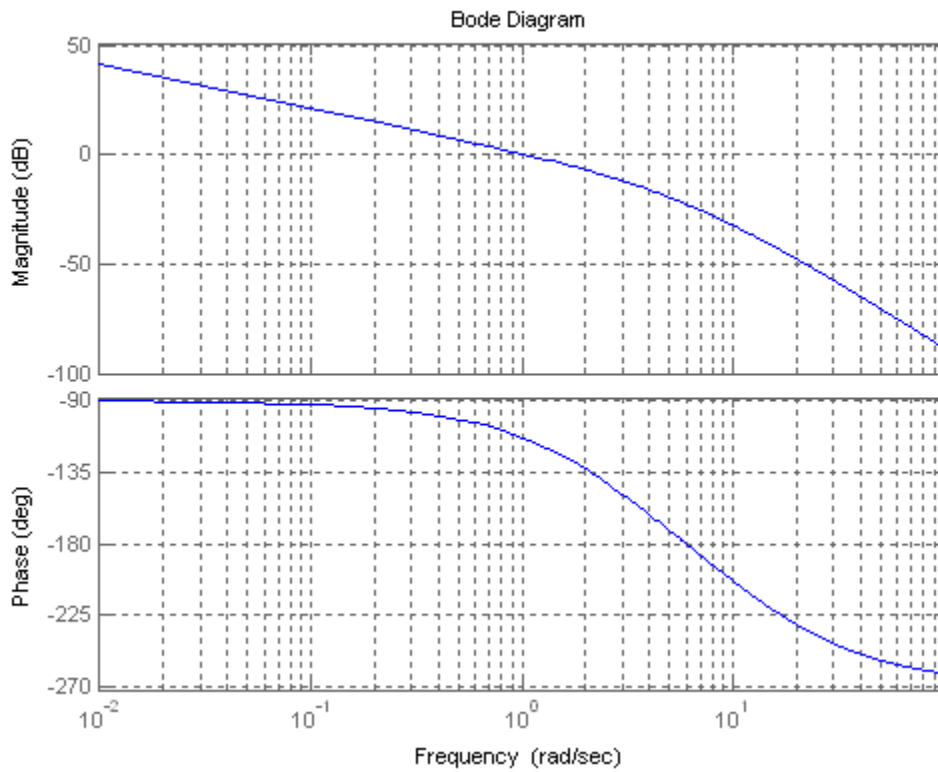

13.

**Program:**

```
numg=8000;
deng=poly([-6 -20 -35]);
G=tf(numg,deng)
ltiview
```

**Computer response:**

```
Transfer function:
      8000
-----
s^3 + 61 s^2 + 1030 s + 4200
```



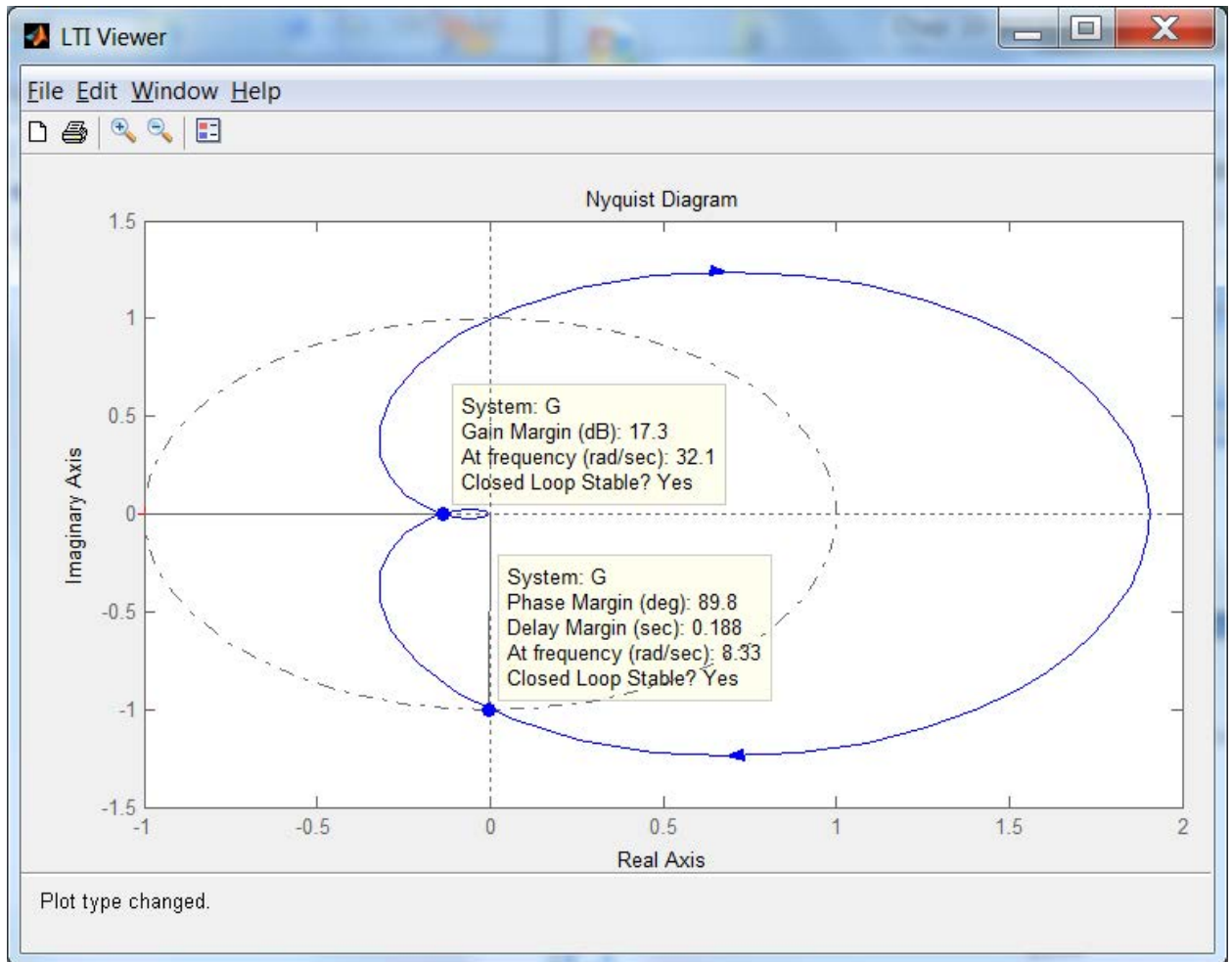

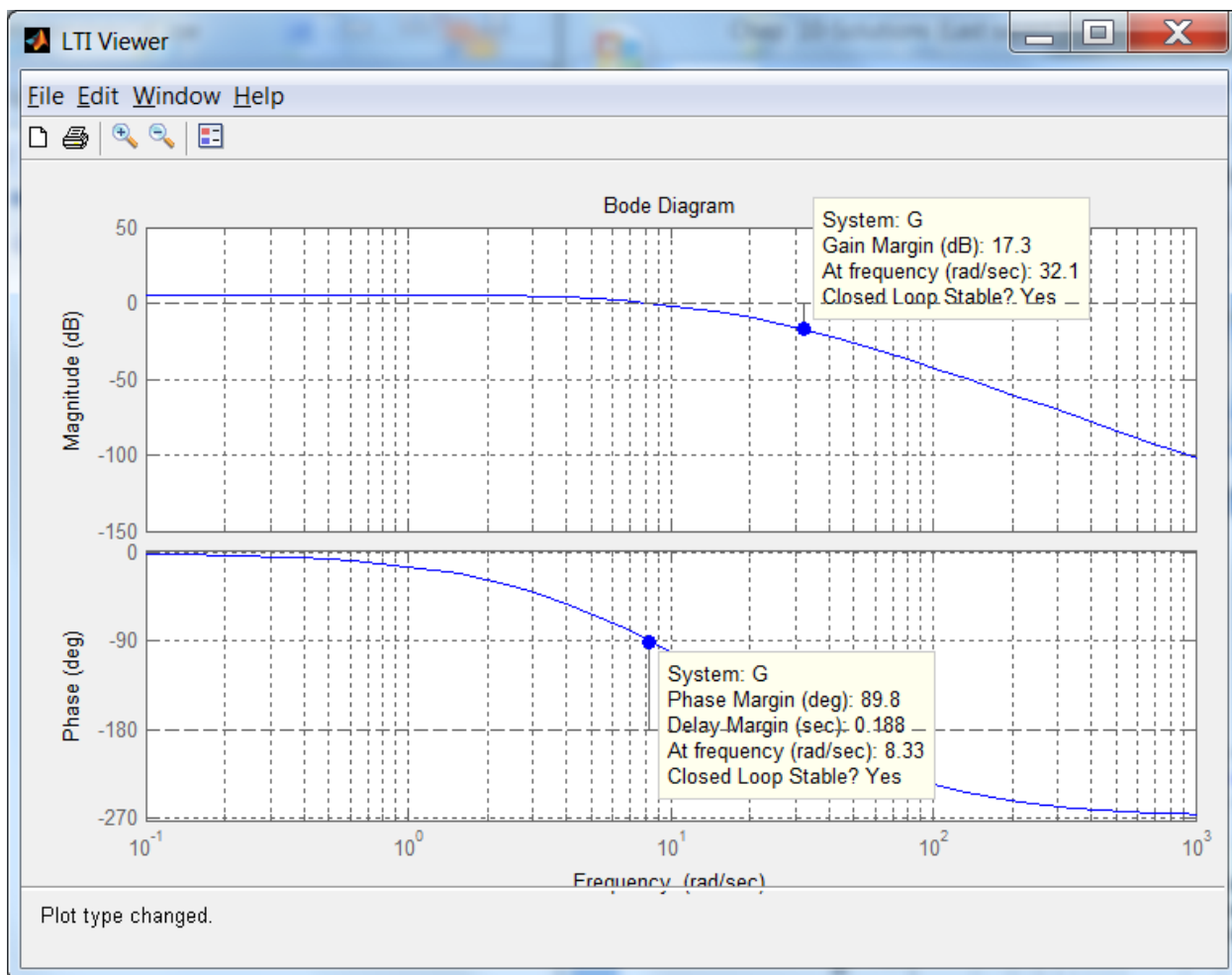

14.

Squaring Eq. (10.51) and setting it equal to  $\left(\frac{1}{\sqrt{2}}\right)^2$  yields

$$\frac{\omega_n^4}{(\omega_n^2 - \omega^2)^2 + 4\zeta^2\omega_n^2\omega^2} = \frac{1}{2}$$

Simplifying,

$$\omega^4 + 2\omega_n^2(2\zeta^2 - 1)\omega^2 - \omega_n^4 = 0$$

Solving for  $\omega^2$  using the quadratic formula and simplifying yields

$$\omega^2 = \omega_n^2 \left[ -(2\zeta^2 - 1) \pm \sqrt{4\zeta^4 - 4\zeta^2 + 2} \right]$$

Taking the square root and selecting the positive term,

$$\omega = \omega_n \sqrt{(1 - 2\zeta^2) + \sqrt{4\zeta^4 - 4\zeta^2 + 2}}$$

15.

a. Using Eq. (10.55),  $\omega_{BW} = 10.06$  rad/s.



a.

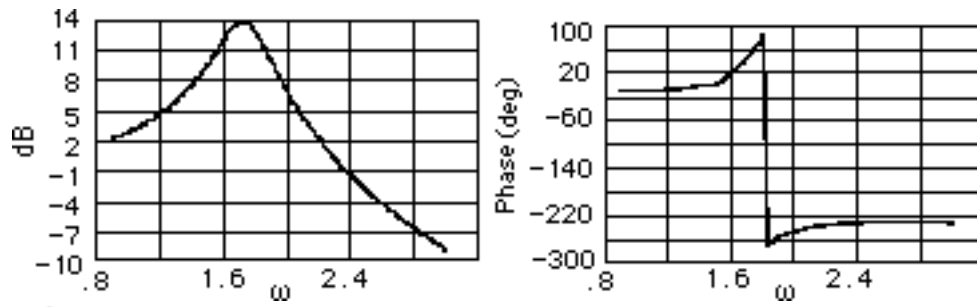

b.

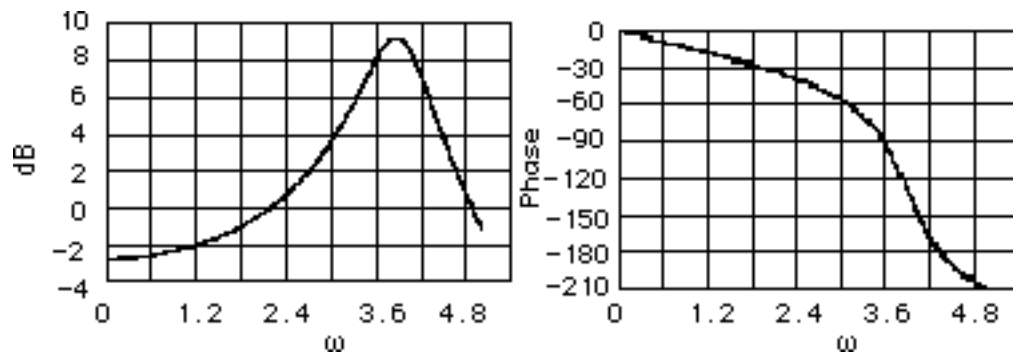

c.

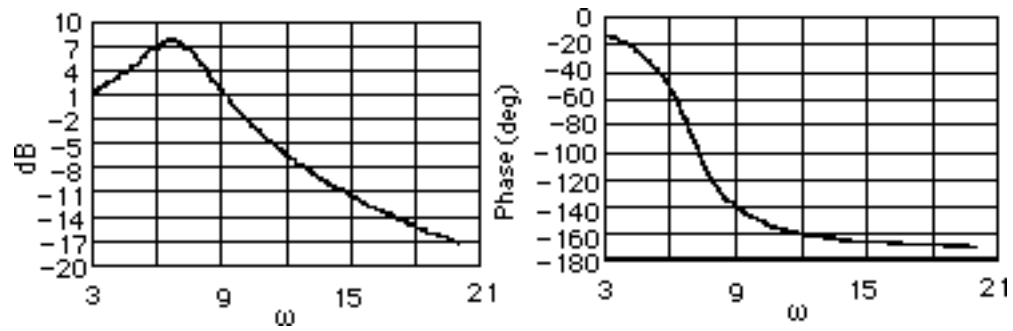

17.

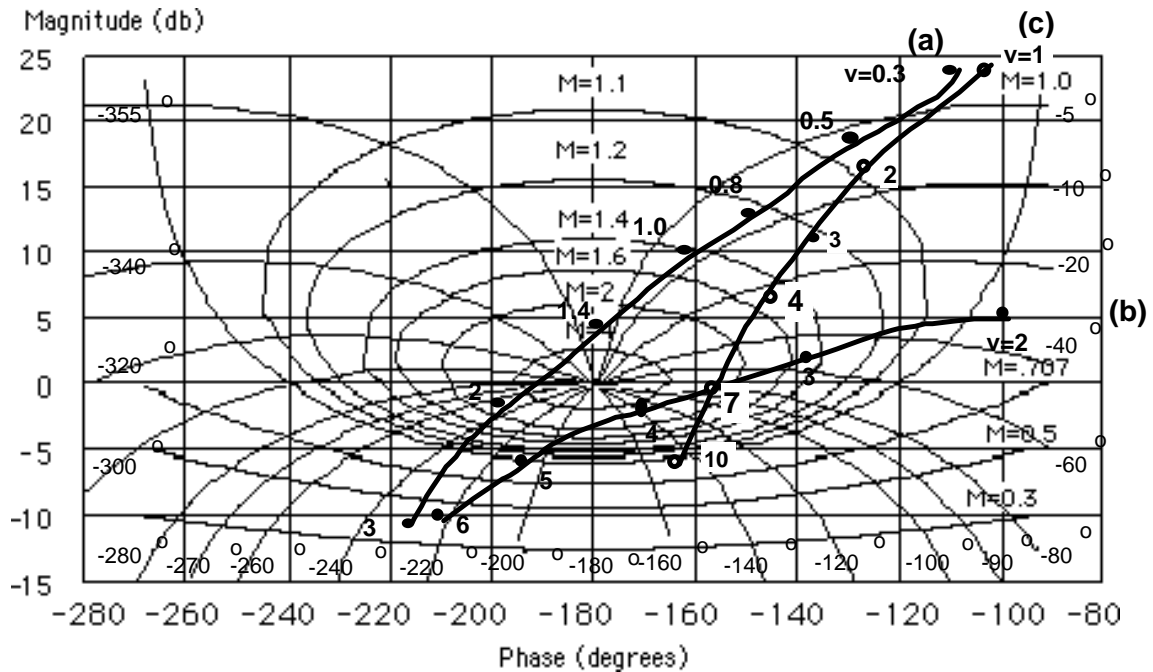

18.

- a. The polar plot is approximately tangent to  $M = 5$ . Using Figure 10.40, the student would estimate 72% overshoot. However, notice that the polar plot intersects the negative real axis at a magnitude greater than unity. Hence, the system is actually unstable and the estimated percent overshoot is not correct.
- b. The polar plot is approximately tangent to  $M = 3$ . Using Figure 10.40, we estimate 58% overshoot.
- c. The polar plot is approximately tangent to  $M = 2.5$ . Using Figure 10.40, we estimate 52% overshoot.

19.

Raise each curve in Problem 17 by (a) 9.54 dB, (b) 7.96 dB, and (c) 3.52 dB, respectively.

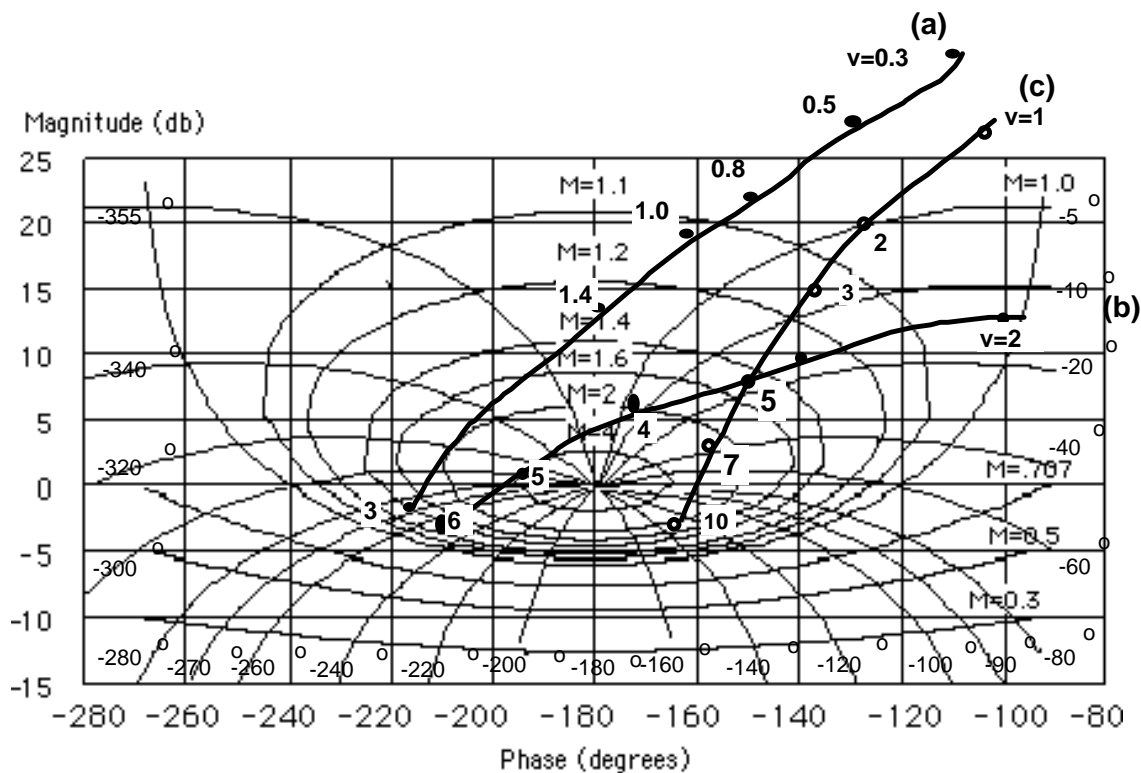

Systems (a) and (b) are both unstable since the open-loop magnitude is greater than unity when the open-loop phase is  $180^\circ$ . System (c) is tangent to approximately  $M = 3$ . Using Figure 10.40, we estimate 58% overshoot.

20.

**Program:**

```
%Enter G(s)*****
numg=[1 5];
deng=[1 4 25 0];
'G(s)'
G=tf(numg,deng)
%Enter K *****
K=input('Type gain, K ');
'T(s)'
T=feedback(K*G,1)
bode(T)
title('Closed-loop Frequency Response')
[M,P,w]=bode(T);
[Mp i]=max(M);
Mp
MpdB=20*log10(Mp)
wp=w(i)
for i=1:length(M);
if M(i)<=0.707;
fprintf('Bandwidth = %g',w(i))
break
end
end
```

**Computer response:**

ans =

G(s)

Transfer function:

$$s + 5$$

-----

$$s^3 + 4 s^2 + 25 s$$

Type gain, K 40

ans =

T(s)

Transfer function:

$$40 s + 200$$

-----

$$s^3 + 4 s^2 + 65 s + 200$$

Mp =

$$6.9745$$

MpdB =

$$16.8702$$

wp =

$$7.8822$$

Bandwidth = 11.4655

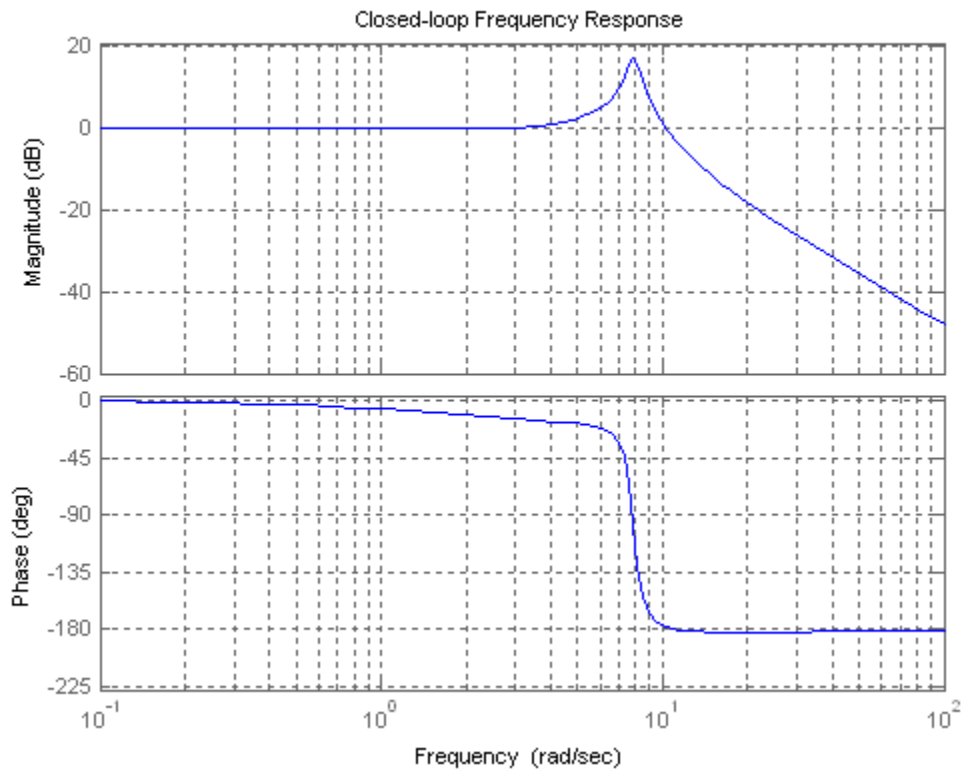

21.

**Program:**

```

numg=[5 30];
deng=[1 4 15 0];
G=tf(numg,deng)
bode(G) %Make a Bode plot.
title('Open-Loop Frequency Response') %Add a title to the Bode plot.
[Gm,Pm,Wcp,Wcg]=margin(G); %Find margins and margin
%frequencies.
'Gain margin(dB); Phase margin(deg.); 0 dB freq. (r/s);'
'180 deg. freq. (r/s)' %Display label.
margins=[20*log10(Gm),Pm,Wcg,Wcp] %Display margin data.
ltiview

```

**Computer response:**

```

Transfer function:
      5 s + 30
-----
s^3 + 4 s^2 + 15 s

```

ans =

Gain margin(dB); Phase margin(deg.); 0 dB freq. (r/s);



ans =

180 deg. freq. (r/s)

margins =

15.5649 65.1103 2.4319 6.7088

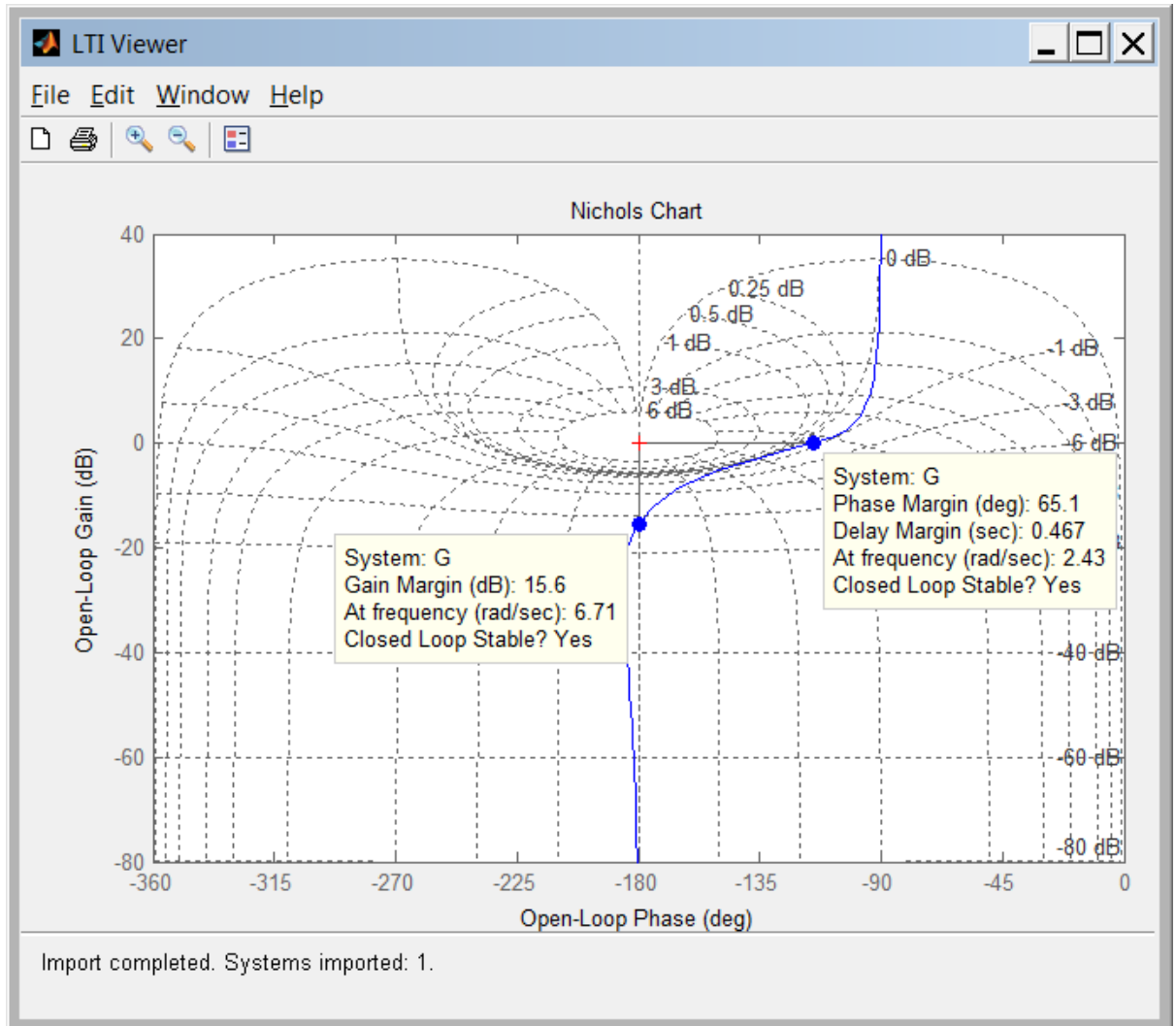

22.

**Program:**

```

%Enter G(s)*****
numg=5*[1 6];
deng=[1 4 15 0];
'Open-Loop System'
'G(s)'
G=tf(numg,deng)
clf
w=.10:1:10;
nichols(G,w)
ngrid
title('Nichols Plot')

```

```

[M,P]=nichols(G,w);
for i=1:1:length(M);
if M(i)<=0.45;
BW=w(i);
break
end
end
pause
MpdB=input('Enter Mp in dB from Nichols Plot ');
Mp=10^(MpdB/20);
z2=roots([4,-4,(1/Mp^2)]);%Since Mp=1/sqrt(4z^2(1-z^2))
z1=sqrt(z2);
z=min(z1);
Pos=exp(-z*pi/(sqrt(1-z^2)));
Ts=(4/(BW*z))*sqrt((1-z^2)+sqrt(4*z^4-4*z^2+2));
Tp=(pi/(BW*sqrt(1-z^2)))*sqrt((1-z^2)+sqrt(4*z^4-4*z^2+2));
'Closed-Loop System'
'T(s)'
T=feedback(G,1)
bode(T)
title('Closed-Loop Frequency Response Plots')
fprintf('\nDamping Ratio = %g',z)
fprintf(', Percent Overshoot = %g',Pos*100)
fprintf(', Bandwidth = %g',BW)
fprintf(', Mp (dB) = %g',MpdB)
fprintf(', Mp = %g',Mp)
fprintf(', Settling Time = %g',Ts)
fprintf(', Peak Time = %g',Tp)
pause
step(T)
title('Closed-Loop Step Response')

```

**Computer response:**

ans =

Open-Loop System

ans =

G(s)

Transfer function:

$$5s + 30$$

$$\text{-----}$$

$$s^3 + 4s^2 + 15s$$

Enter Mp in dB from Nichols Plot 0

ans =

Closed-Loop System

ans =

T(s)

Transfer function:

$$\frac{5s + 30}{s^3 + 4s^2 + 20s + 30}$$

Damping Ratio = 0.707107, Percent Overshoot = 4.32139, Bandwidth = 5.1, Mp (dB) = 0, Mp = 1, Settling Time = 1.35847, Peak Time = 1.06694>>

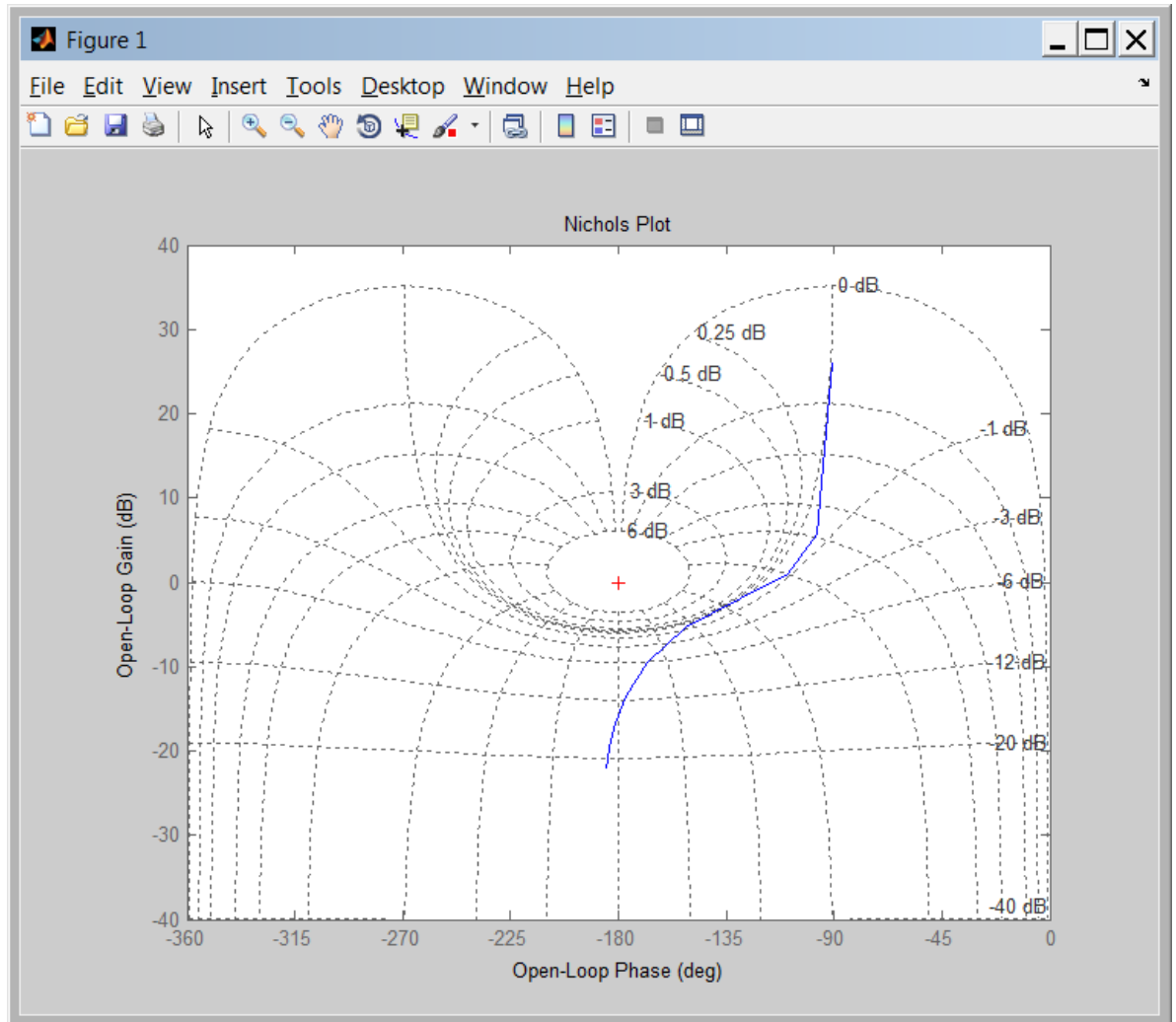

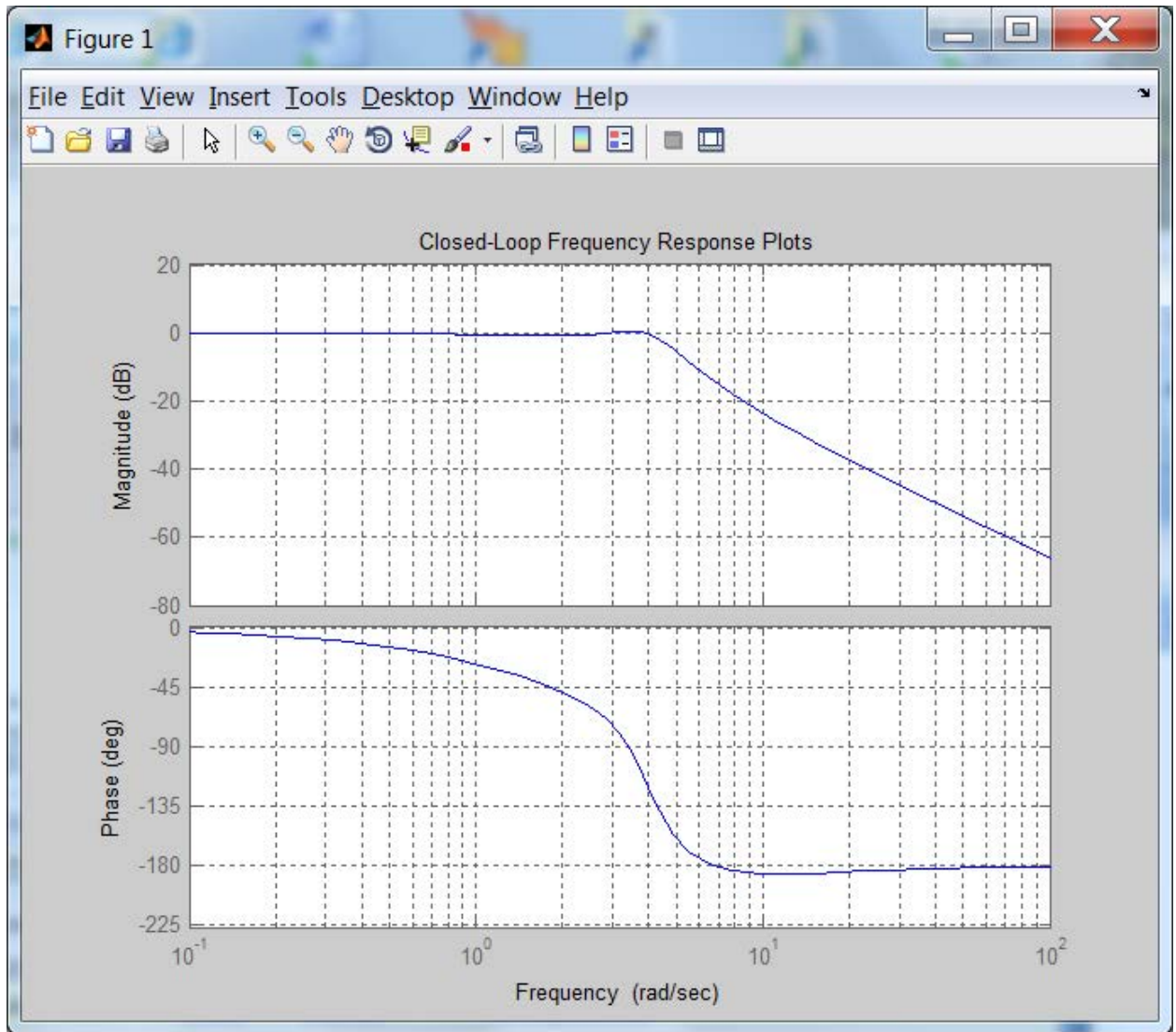

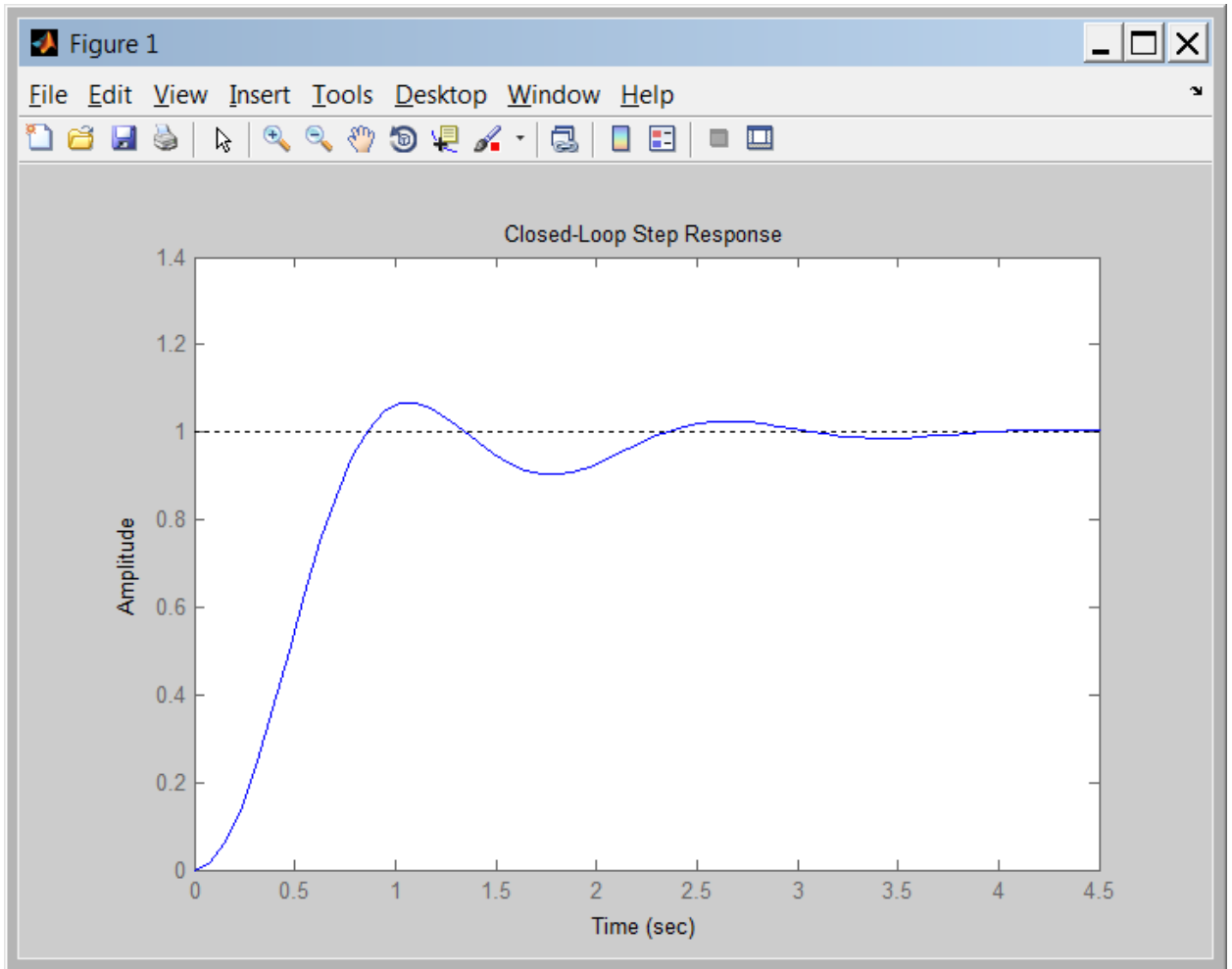

23.

**System 1:** Using non-asymptotic frequency response plots, the zero dB crossing is at 9.7 rad/s at a phase of  $-163.2^\circ$ . Therefore the phase margin is  $180^\circ - 163.2^\circ = 16.8^\circ$ .  $|G(j\omega)|$  is down 7 dB at 14.75 rad/s. Therefore the bandwidth is 14.75 rad/s. Using Eq. (10.73),  $\zeta = 0.15$ . Using Eq. (4.38), %OS = 62.09%. Eq. (10.55) yields  $T_s = 2.76$  s, and Eq. (10.56) yields  $T_p = 0.329$  s.

**System 2:** Using non-asymptotic frequency response plots, the zero dB crossing is at 6.44 rad/s at a phase of  $-150.73^\circ$ . Therefore the phase margin is  $180^\circ - 150.73^\circ = 29.27^\circ$ .  $|G(j\omega)|$  is down 7 dB at 10.1 rad/s. Therefore the bandwidth is 10.1 rad/s. Using Eq. (10.73),  $\zeta = 0.262$ . Using Eq. (4.38), %OS = 42.62%. Eq. (10.55) yields  $T_s = 2.23$  s, and Eq. (10.56) yields  $T_p = 0.476$  s.

24.

a.

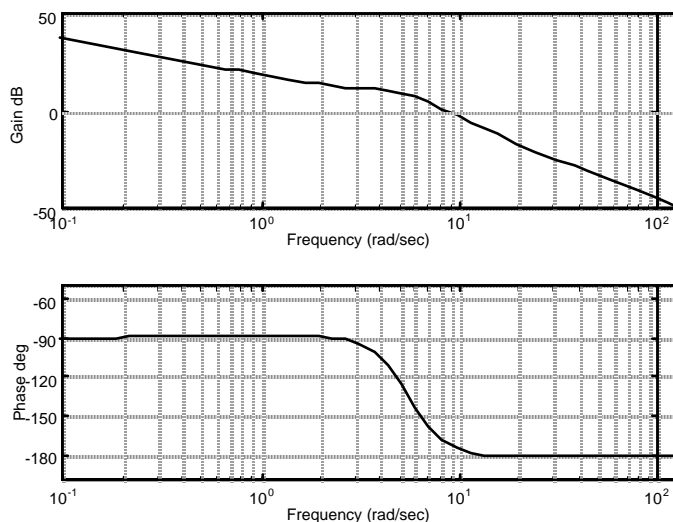

b. Zero dB frequency = 7.8023; Looking at the phase diagram at this frequency, the phase margin is 8.777 degrees. Using Eq. (10.73) or Figure 10.48,  $\zeta = 0.08$ . Thus, %OS = 77.7.

c.

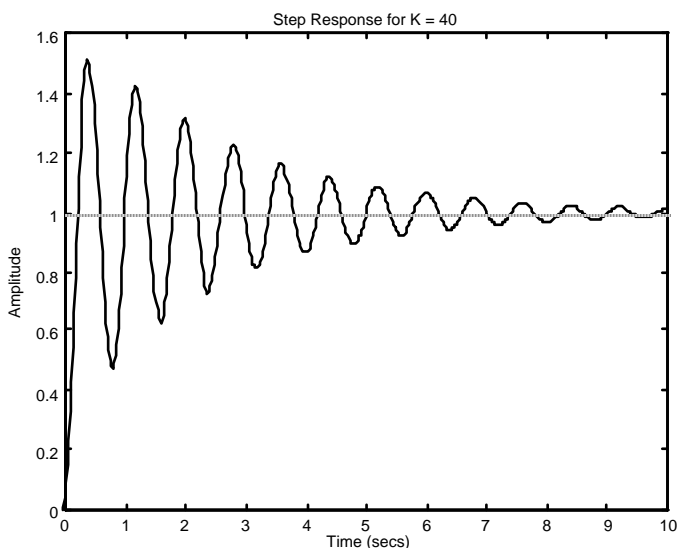

25.

From the Bode plots: Gain margin = 14.96 dB; phase margin = 49.57°; 0 dB frequency = 2.152 rad/s; 180° frequency = 6.325 rad/s; bandwidth(@-7 dB point) = 3.8 rad/s. From Eq. (10.73)  $\zeta = 0.48$ ; from Eq. (4.38) %OS = 17.93; from Eq. (10.55)  $T_s = 2.84$  s; from Eq. (10.56)  $T_p = 1.22$  s.

26.

**Program:**

```
G=zpk([-2],[0 -1 -4],100)
%G=zpk([-3 -5],[0 -2 -4 -6],50)
G=tf(G)
```

```

bode(G)
title('System 1')
%title('System 2')
pause
%Find Phase Margin
[Gm,Pm,Wcg,Wcp]=margin(G);
w=1:.01:20;
[M,P,w]=bode(G,w);
%Find Bandwidth
for k=1:1:length(M);
    if 20*log10(M(k))+7<=0;
        'Mag'
        20*log10(M(k))
        'BW'
        wBW=w(k)
        break
    end
end
%Find Damping Ratio,Percent Overshoot, Settling Time, and Peak Time
for z= 0:.01:10
    Pt=atan(2*z/(sqrt(-2*z^2+sqrt(1+4*z^4))))*(180/pi);
    if (Pm-Pt)<=0
        z;
        Po=exp(-z*pi/sqrt(1-z^2));
        Ts=(4/(wBW*z))*sqrt((1-2*z^2)+sqrt(4*z^4-4*z^2+2));
        Tp=(pi/(wBW*sqrt(1-z^2)))*sqrt((1-2*z^2)+sqrt(4*z^4-4*z^2+2));
        fprintf('Bandwidth = %g ',wBW)
        fprintf('Phase Margin = %g',Pm)
        fprintf(', Damping Ratio = %g',z)
        fprintf(', Percent Overshoot = %g',Po*100)
        fprintf(', Settling Time = %g',Ts)
        fprintf(', Peak Time = %g',Tp)
        break
    end
end
end
T=feedback(G,1);
step(T)
title('Step Response System 1')
%title('Step Response System 2')

```

**Computer response:**

Zero/pole/gain:

100 (s+2)

-----  
s (s+1) (s+4)

Transfer function:

100 s + 200

-----  
s^3 + 5 s^2 + 4 s

ans =

Mag

ans =

-7.0007

10-38 Chapter 10: Frequency Response Methods

ans =

BW

wBW =

14.7500

Bandwidth = 14.75 Phase Margin = 16.6617, Damping Ratio = 0.15, Percent  
Overshoot = 62.0871, Settling Time = 2.76425, Peak Time = 0.329382

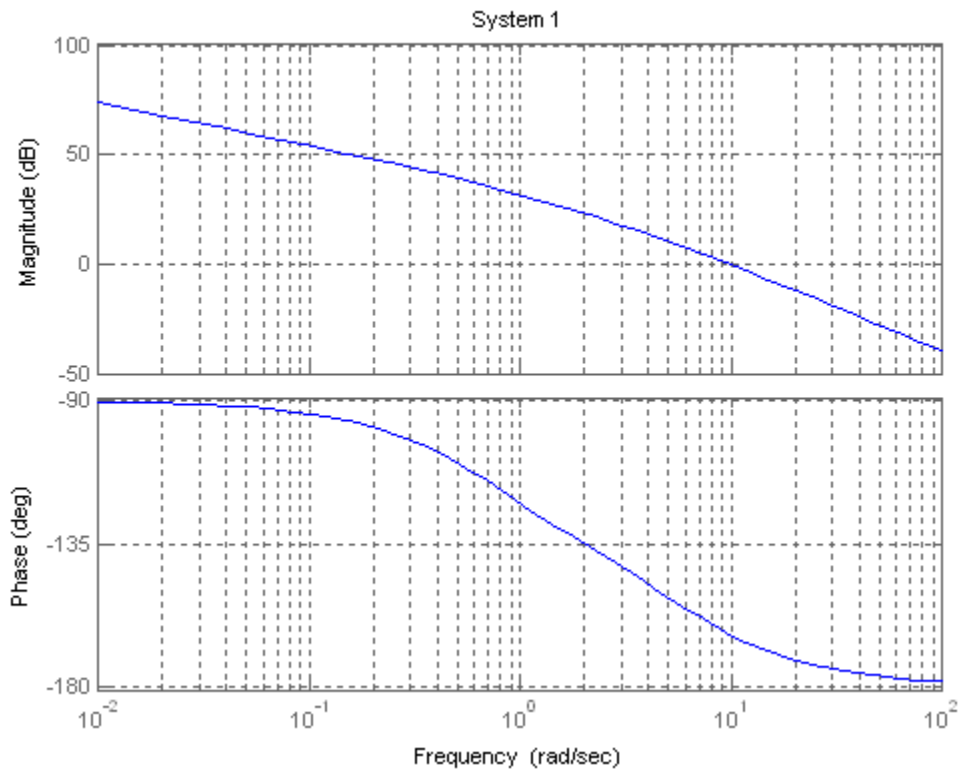



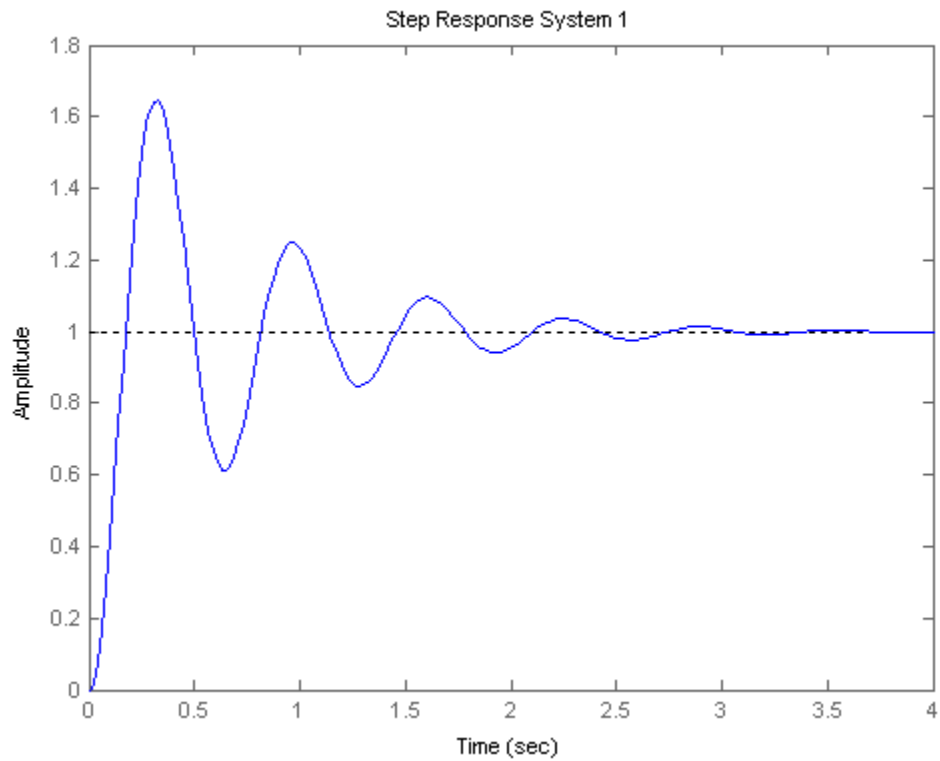

Zero/pole/gain:

$$50 (s+3) (s+5)$$

-----

$$s (s+2) (s+4) (s+6)$$

Transfer function:

$$50 s^2 + 400 s + 750$$

-----

$$s^4 + 12 s^3 + 44 s^2 + 48 s$$

ans =

Mag

ans =

$$-7.0026$$

ans =

10-40 Chapter 10: Frequency Response Methods

BW

wBW =

10.1100

Bandwidth = 10.11 Phase Margin = 29.2756, Damping Ratio = 0.27, Percent Overshoot

= 41.439, Settling Time = 2.1583, Peak Time =

0.475337

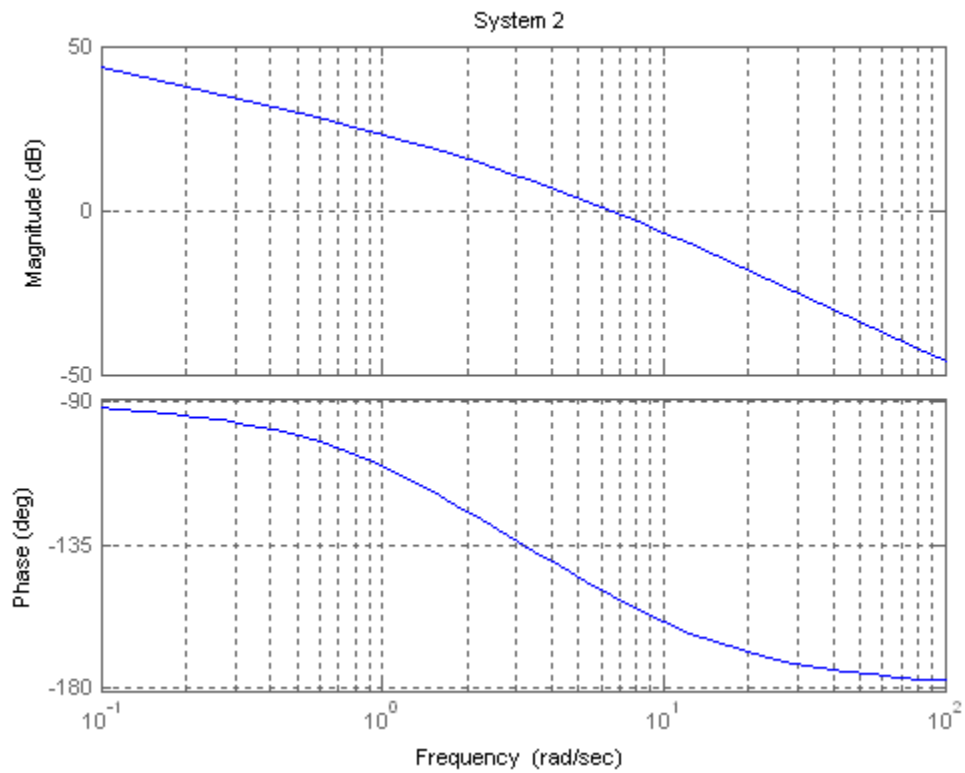

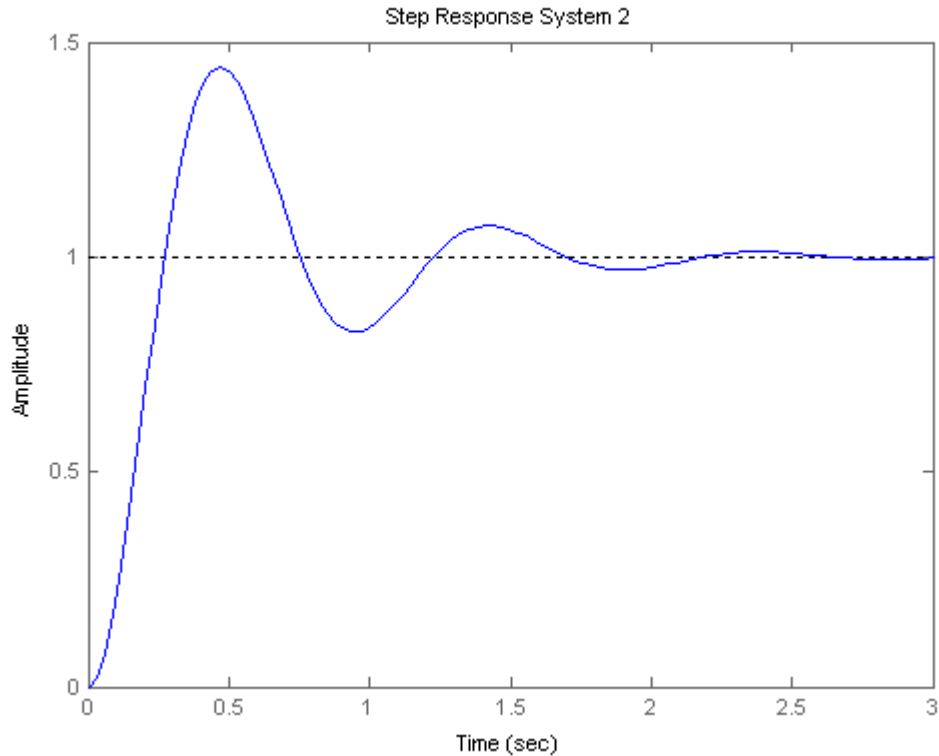

27.

The phase margin of the given system is  $20^\circ$ . Using Eq. (10.73),  $\zeta = 0.176$ . Eq. (4.38) yields 57% overshoot. The system is Type 1 since the initial slope is  $-20$  dB/dec. Continuing the initial slope down to the 0 dB line yields  $K_v = 4$ . Thus, steady-state error for a unit step input is zero; steady state error for a unit ramp input is  $\frac{1}{K_v} = 0.25$ ; steady-state error for a parabolic input is infinite.

28.

The magnitude response is the same for all time delays and crosses zero dB at 0.5 rad/s. The following is a plot of the magnitude and phase responses for the given time delays:

a.

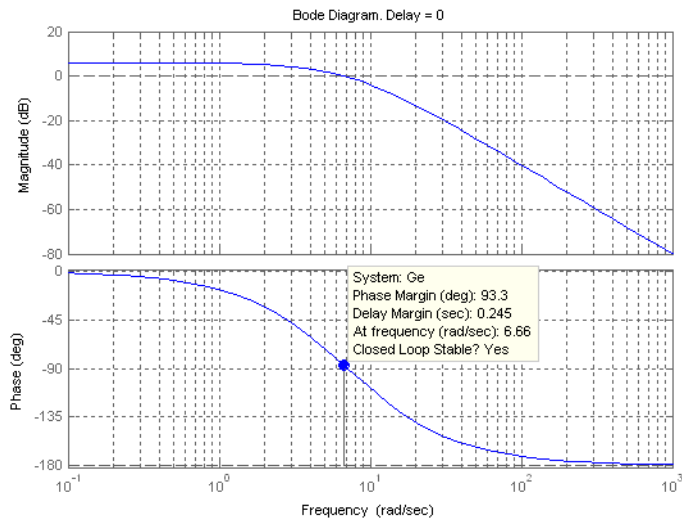

For  $T = 0$ ,  $\Phi_M = 93.3^\circ$ ; System is stable.

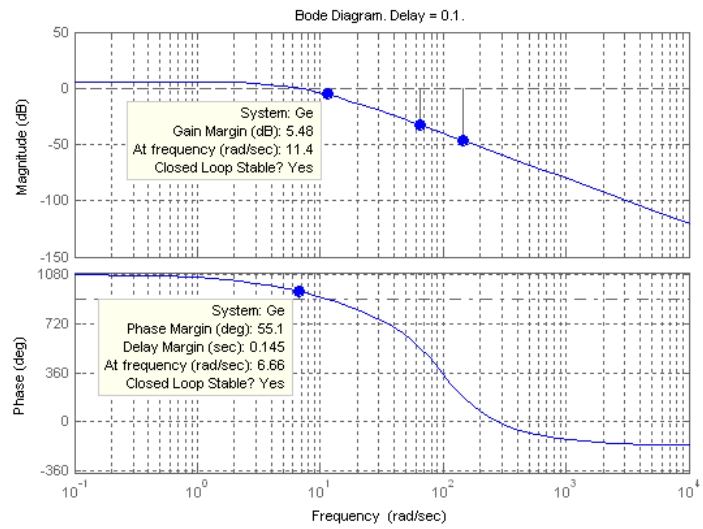

For  $T = 0.1$ ,  $\Phi_M = 55.1^\circ$ ; System is stable.

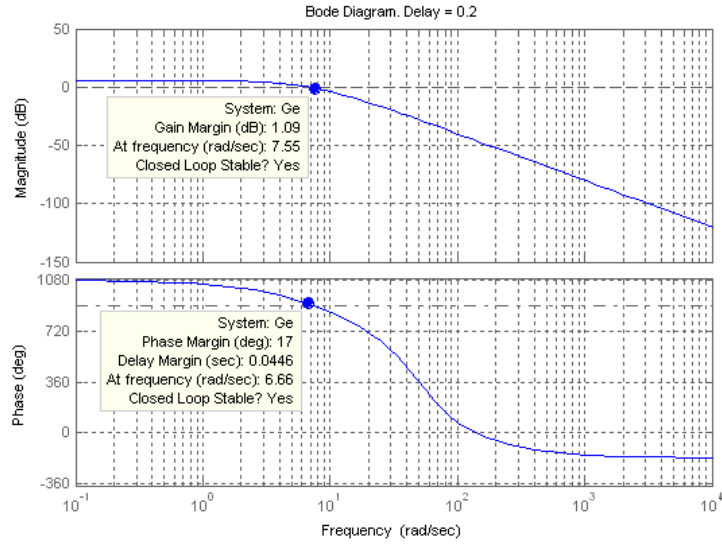

For  $T = 0.2$ ,  $\Phi_M = 17^\circ$ ; System is stable.

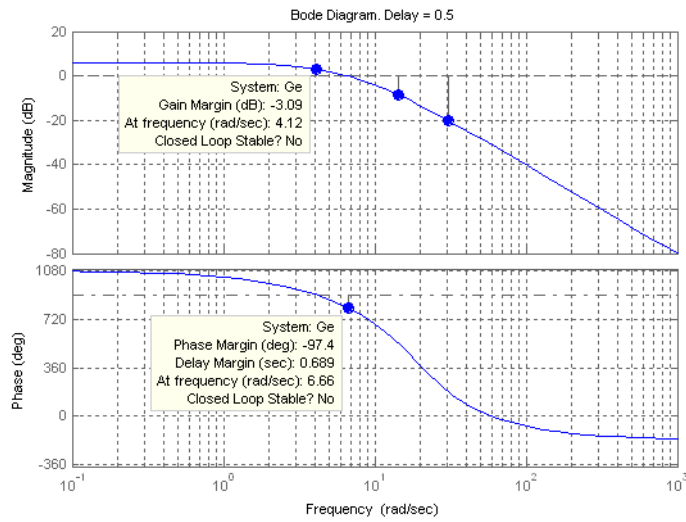

For  $T = 0.5$ ,  $\Phi_M = -97^\circ$ ; System is unstable.

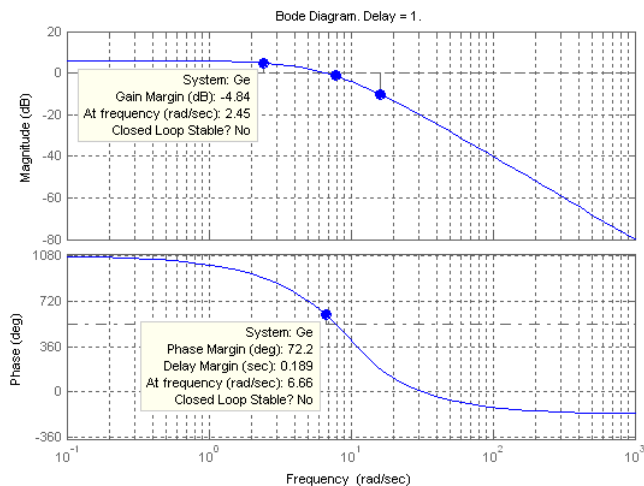

For  $T = 1$ ,  $\Phi_M = 72.2^\circ$ ; System is unstable because the gain margin is  $-4.84$  dB.

**b.**

For  $T = 0$ , the phase response reaches  $180^\circ$  at infinite frequency. Therefore the gain margin is infinite. The system is stable.

For  $T = 0.1$ , the phase response is  $-180^\circ$  at  $11.4$  rad/s. The magnitude response is  $-5.48$  dB at  $11.4$  rad/s. Therefore, the gain margin is  $5.48$  dB. The system is stable.

For  $T = 0.2$ , the phase response is  $-180^\circ$  at  $7.55$  rad/s. The magnitude response is  $-1.09$  dB at  $7.55$  rad/s. Therefore, the gain margin is  $1.09$  dB and the system is stable.

For  $T = .5$ , the phase response is  $-180^\circ$  at  $4.12$  rad/s. The magnitude response is  $+3.09$  dB at  $4.12$  rad/s. Therefore, the gain margin is  $-3.09$  dB and the system is unstable.

For  $T = 1$ , the phase response is  $-180^\circ$  at  $2.45$  rad/s. The magnitude response is  $+4.84$  dB at  $2.45$  rad/s. Therefore, the gain margin is  $-4.84$  dB and the system is unstable.

**c.**

$T = 0$ ;  $T = 0.1$ ;  $T = 0.2$

**d.**

$T = 0.5$ ,  $-3.09$  dB;  $T = 1$ ,  $-4.84$  dB;

**29.**

The Bode plots for  $K = 1$  and  $0.5$  second delay is:

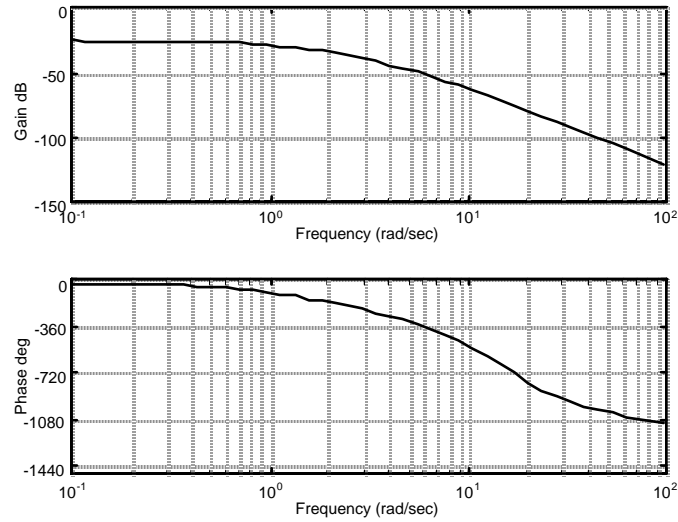

The phase is  $-180^\circ$  at 2.12 rad/s. At this frequency, the gain is -34.76 dB. Thus the gain can be raised by 34.76 dB = 54.71. Hence for stability,  $0 < K < 54.71$ .

30.

The Bode plots for  $K = 40$  and a delay of 0.5 second is shown below.

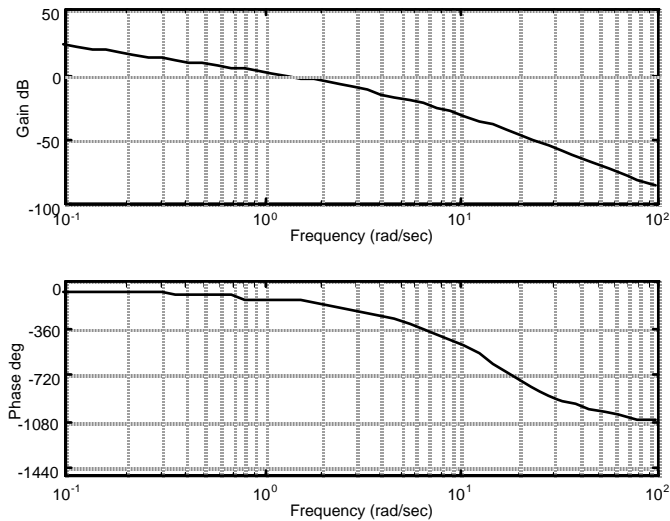

The magnitude curve crosses zero dB at a frequency of 1.0447 rad/s. At this frequency, the phase plot shows a phase margin of 35.74 degrees. Using Eq. (10.73) or Figure 10.48,  $\zeta = 0.33$ . Thus, %OS = 33.3.

31.

**Program:**

```
%Enter G(s)*****
numg1=1;
deng1=poly([0 -3 -12]);
'G1(s)'
G1=tf(numg1,deng1)
[numg2,deng2]=pade(0.5,5);
```

```

    'G2(s) (delay)'
    G2=tf(numg2,deng2)
    'G(s)=G1(s)G2(s)'
    G=G1*G2
    %Enter K *****
    K=input('Type gain, K ');
    T=feedback(K*G,1);
    step(T)
    title(['Step Response for K = ',num2str(K)])

```

**Computer response:**

ans =

G1(s)

Transfer function:

1

-----

$s^3 + 15 s^2 + 36 s$

ans =

G2(s) (delay)

Transfer function:

$-s^5 + 60 s^4 - 1680 s^3 + 2.688e004 s^2 - 2.419e005 s + 9.677e005$

-----

$s^5 + 60 s^4 + 1680 s^3 + 2.688e004 s^2 + 2.419e005 s + 9.677e005$

ans =

G(s)=G1(s)G2(s)

Transfer function:

$-s^5 + 60 s^4 - 1680 s^3 + 2.688e004 s^2 - 2.419e005 s + 9.677e005$

-----

$s^8 + 75 s^7 + 2616 s^6 + 5.424e004 s^5 + 7.056e005 s^4 + 5.564e006 s^3$

$+ 2.322e007 s^2 + 3.484e007 s$



Type gain,  $K = 40$

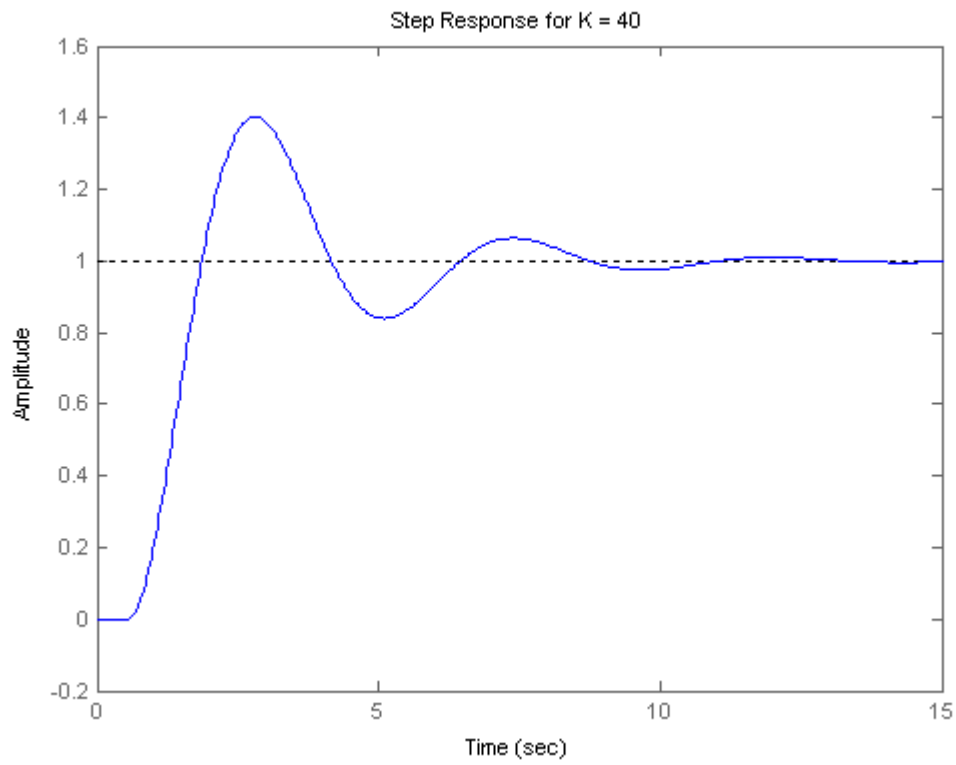

32.

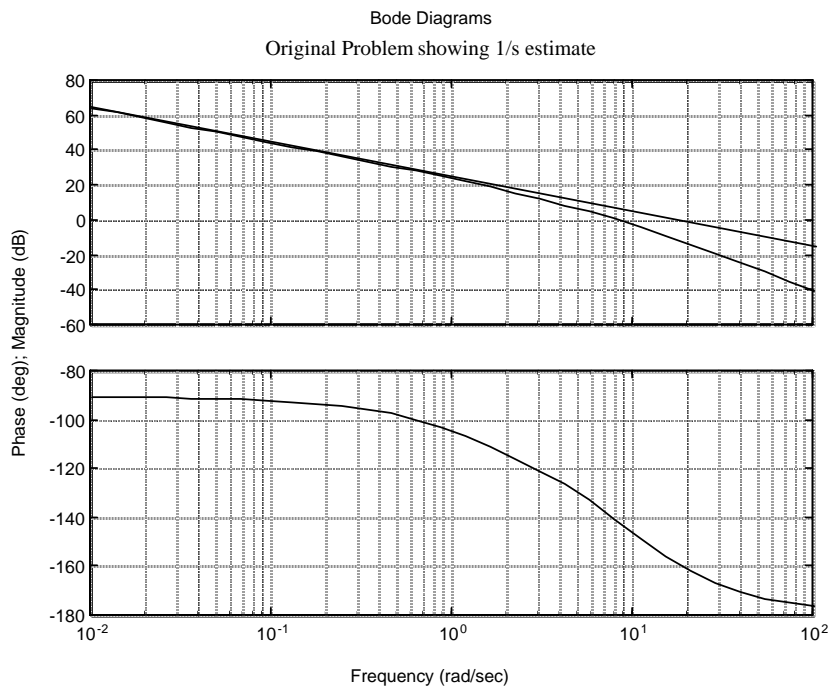

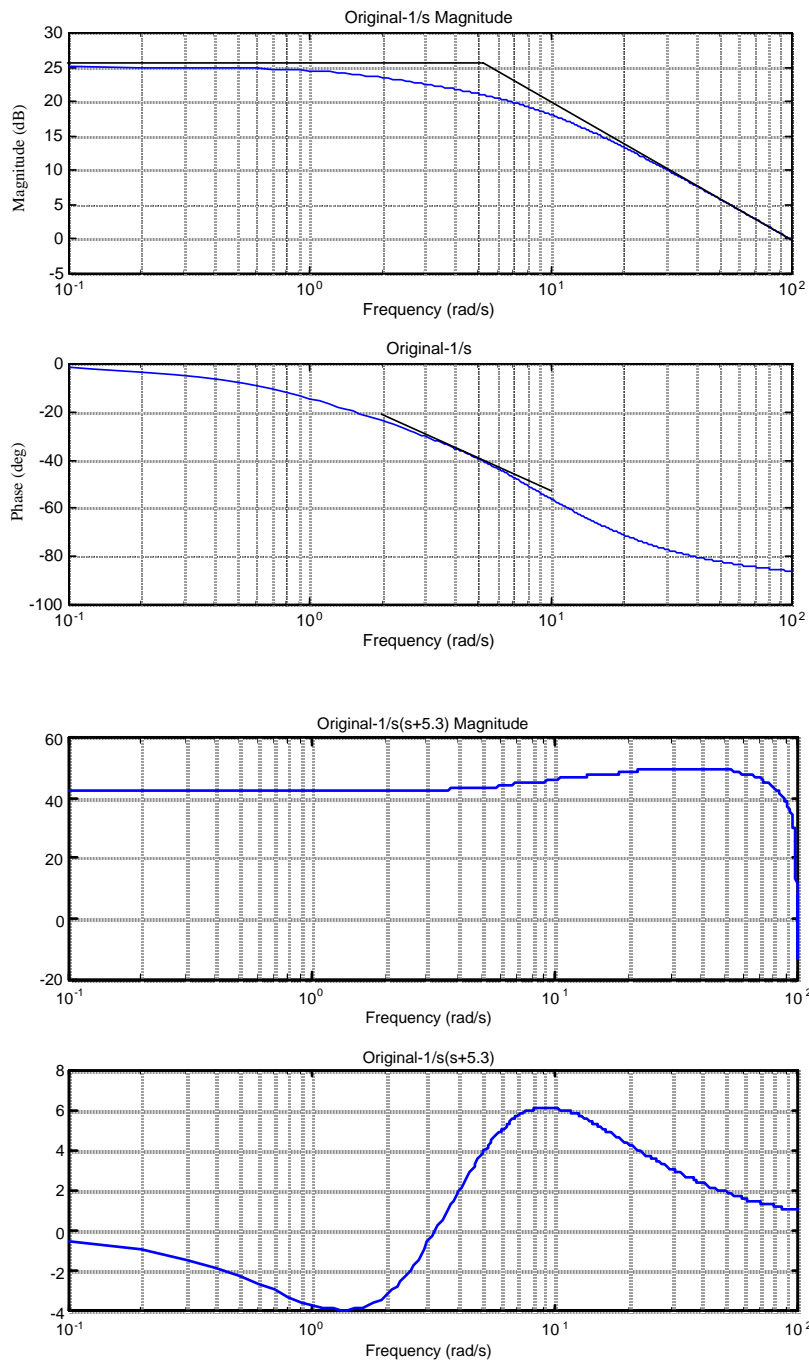

Estimated  $K = 41 \text{ dB} = 112$ . Therefore, final estimate is  $G(s) = \frac{112}{s(s + 5.3)}$ .

33.

**Program:**

```
%Generate total system Bode plots - numg0,deng0 - M0,P0
clf
numg0=12*poly([-1 -20]);
deng0=conv([1 7],[1 4 100]);
G0=tf(numg0,deng0);
w=0.1:0.1:100;
```

```

[M0,P0]=bode(G0,w);
M0=M0(:,:);
P0=P0(:,:);
[20*log10(M0),P0,w];
bode(G0,w)
pause
%Subtract (s+1) [numg1,deng1] and generate Bode plot-M2,P2
numg1=[1 1];
deng1=1;
G1=tf(numg1,deng1);
[M1,P1]=bode(G1,w);
M1=M1(:,:);
P1=P1(:,:);
M2=20*log10(M0)-20*log10(M1);
P2=P0-P1;
clf
subplot(2,1,1)
semilogx(w,M2)
grid
subplot(2,1,2)
semilogx(w,P2)
grid
pause
%Subtract  $10^2/(s^2+2*0.3*10s+10^2)$  [numg2,deng2] and generate Bode plot-
M4,P4
numg2=100;
deng2=[1 2*0.3*10 10^2];
G2=tf(numg2,deng2);
[M3,P3]=bode(G2,w);
M3=M3(:,:);
P3=P3(:,:);
M4=M2-20*log10(M3);
P4=P2-P3;
clf
subplot(2,1,1)
semilogx(w,M4)
grid
subplot(2,1,2)
semilogx(w,P4)
grid
pause
%Subtract  $(8.5/23)(s+23)/(s+8.5)$  [numg3,deng3] and generate Bode plot-M6,P6
numg3=(8.5/23)*[1 23];
deng3=[1 8.5];
G3=tf(numg3,deng3);
[M5,P5]=bode(G3,w);
M5=M5(:,:);
P5=P5(:,:);
M6=M4-20*log10(M5);
P6=P4-P5;
clf
subplot(2,1,1)
semilogx(w,M6)
grid
subplot(2,1,2)
semilogx(w,P6)
grid

```

**Computer responses and analysis:**

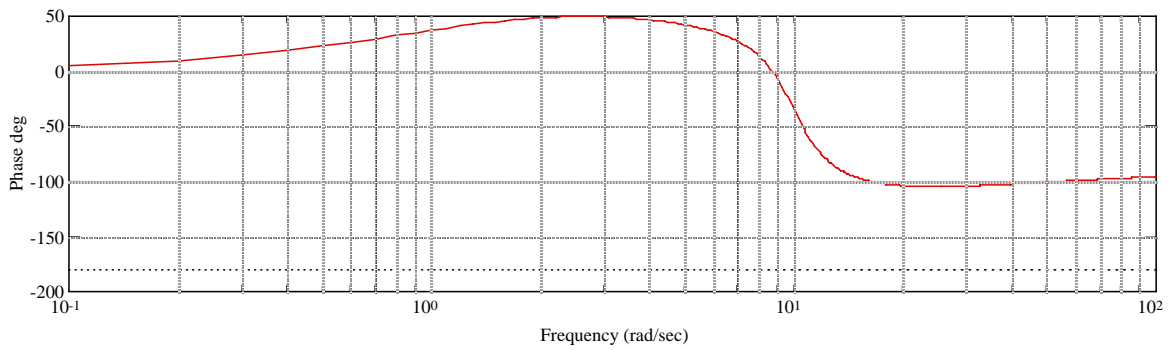
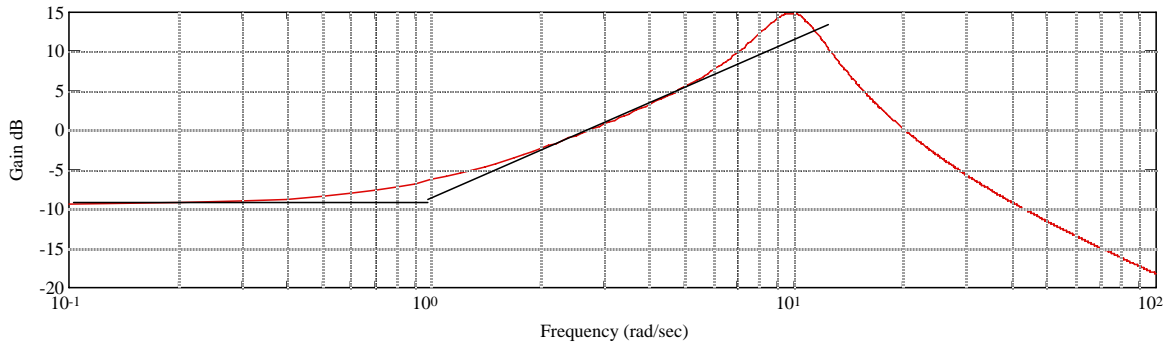

Original data showing estimate of a component, (s+1)

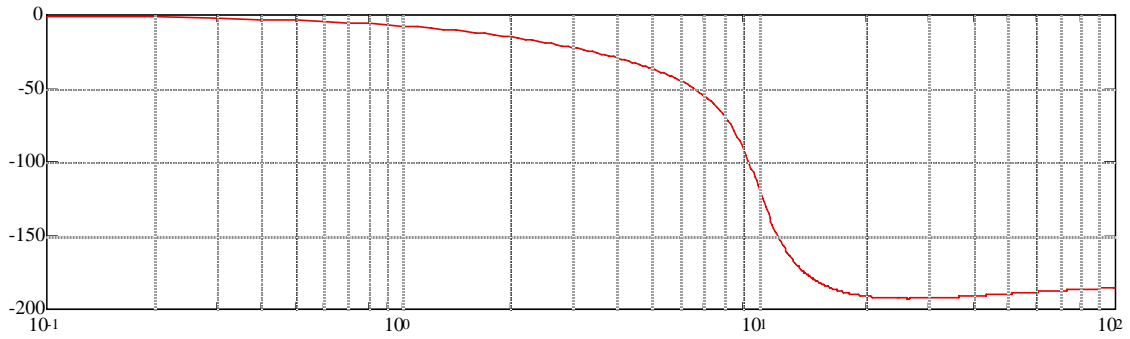
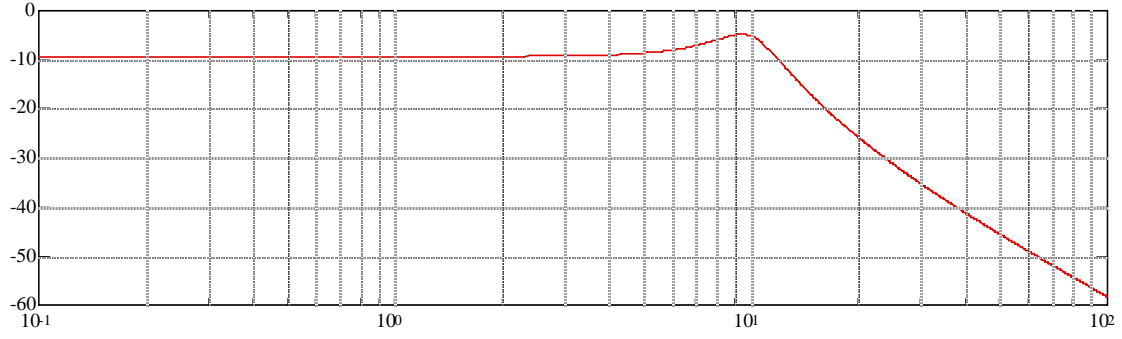

Original data minus  $(s+1)$  showing estimate of  $(10^2/(s^2+2*0.3*10s+10^2))$

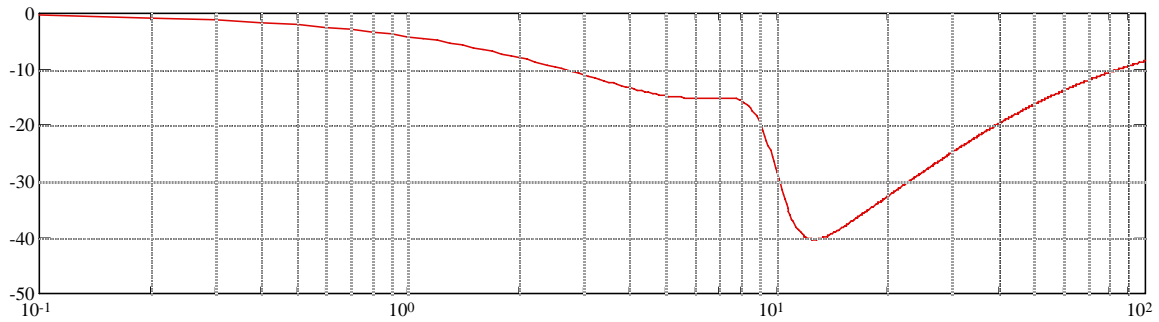
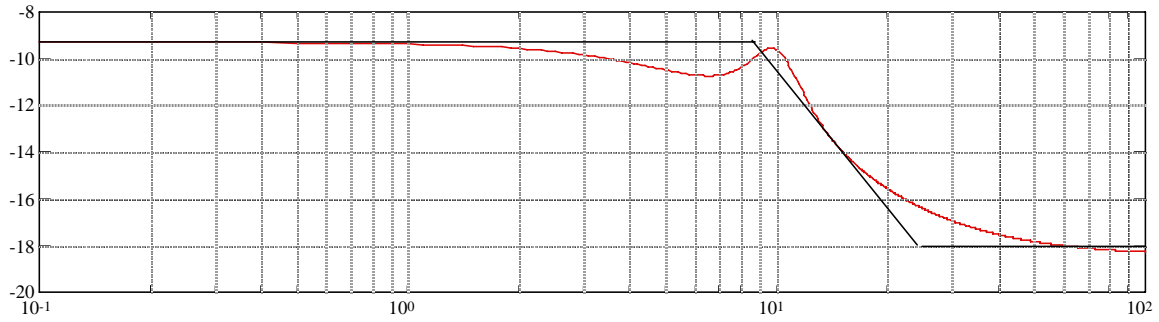

Original data minus  $(s+1)(10^2/(s^2+2*0.3*10s+10^2))$  showing estimate of  $(8.5/23)(s+23)/(s+8.5)$

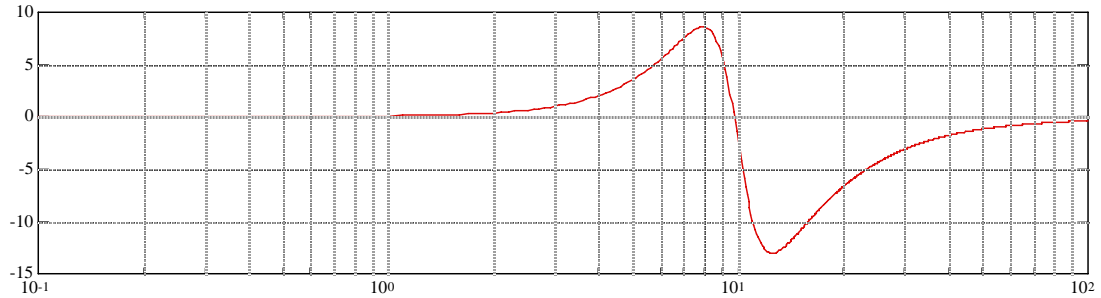
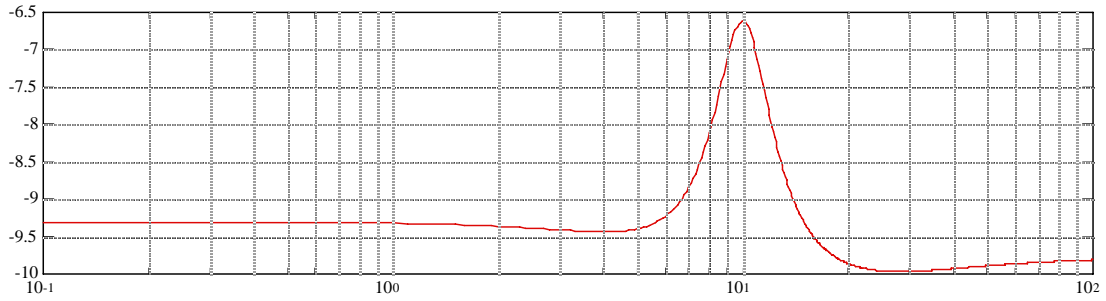

$$\text{Original data minus final estimate of } G(s) = (s + 1) * \frac{100}{s^2 + 6s + 100} * \frac{8.5 s + 23}{23 s + 8.5}$$

Thus the final estimate is  $G(s) = (s + 1) * \frac{100}{s^2 + 6s + 100} * \frac{8.5 s + 23}{23 s + 8.5} * K$ . Since the original plot starts from -10 dB,  $20 \log K = -10$ , or  $K = 0.32$ .

**34.**

The Bode plot is:

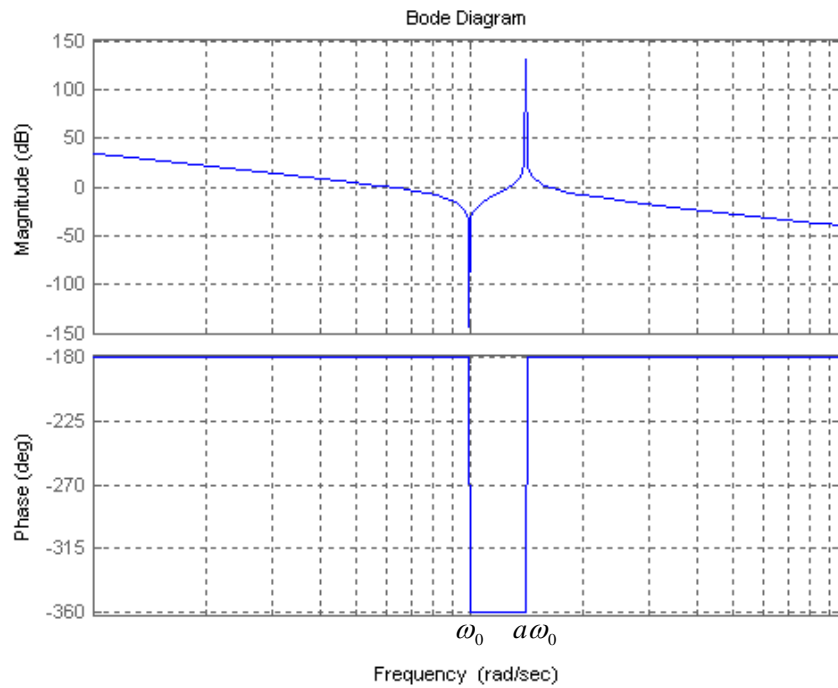

The frequency response is  $P(j\omega) = \frac{\omega_0^2 - \omega^2}{-\omega^2(a\omega_0^2 - \omega^2)}$ , there is no imaginary part so the phase will

be either  $-180^\circ$  or  $0^\circ$ . As  $\omega \rightarrow 0$ ,  $P(j\omega) < 0$  so its phase is  $-180^\circ$ . When  $\omega = \omega_0$ ,  $P(j\omega) = 0$ .

Then for  $\omega_0 < \omega < a\omega_0$  the phase is  $0^\circ$ . When  $\omega = a\omega_0$ ,  $P(j\omega) = \infty$ . And for

$\omega > a\omega_0$   $P(j\omega) < 0$ .  $P(j\omega)$  decreases in the intervals in which  $\omega < \omega_0$  and  $\omega > a\omega_0$ , and will increase when  $\omega_0 < \omega < a\omega_0$ .

35.  
a. The Nyquist plot is:

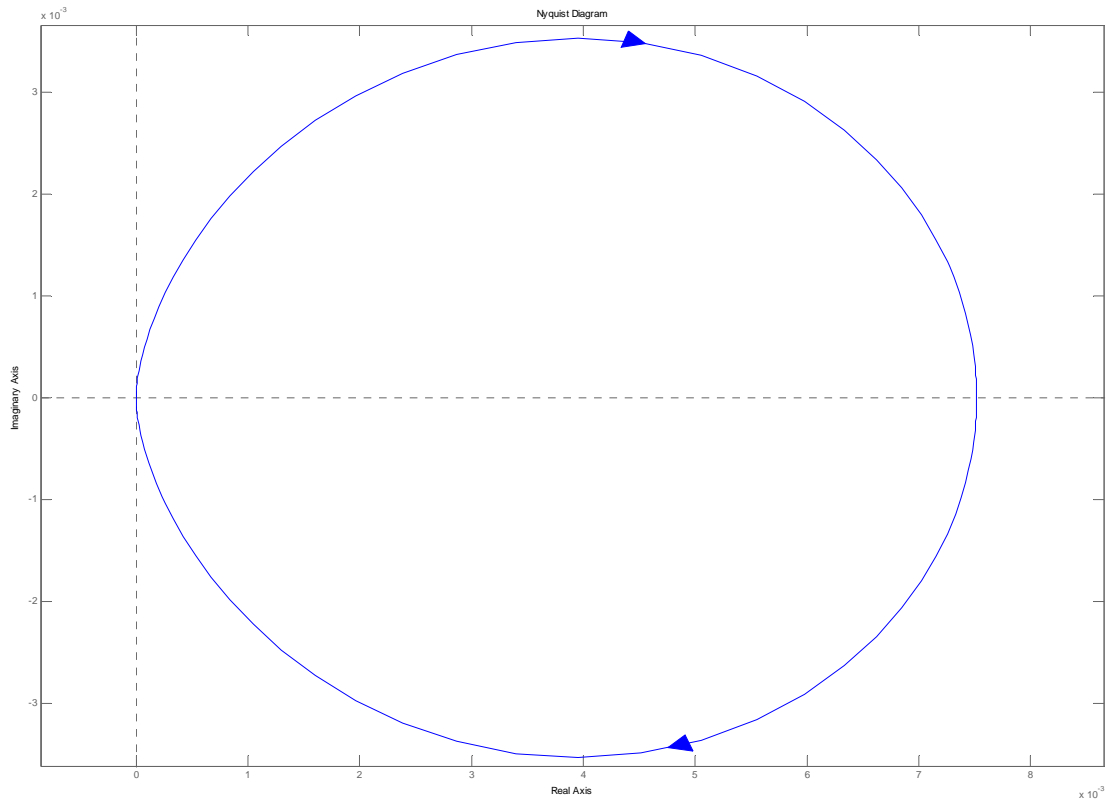

**b.** The gain margin is infinite as the plot never crosses the  $180^\circ$  line. The phase margin is undefined since  $|G(j\omega)| < 1$  at all frequencies.

**c.** The system is closed loop stable for all  $0 < K < \infty$ .

**36.**

The exact Bode plot and the asymptotic approximations are shown on the following figure. The magnitude asymptotes are obtained by noting that when  $\omega \rightarrow 0$ ,  $P(s) \approx \frac{16782}{s}$ . So when

$\omega = 0.1$ ,  $|P(j0.1)| = 167820 = 104.5\text{db}$  and the slope of the line is  $-6\text{db/oct}$ . This means that  $|P(j0.2)| = 104.5\text{db} - 6\text{db} = 98.5\text{db}$ . So a line is drawn between these two points until  $\omega = 2.89$  is reached. For higher frequencies the slope is  $-12\text{db/oct}$ , so the line is continued.

To plot the phase asymptote at very low frequencies the phase is  $-180^\circ$  due to the integrator until  $2.89/10 = 0.289\text{rad/sec}$ . At very high frequencies from  $2.89 \cdot 10 = 28.9\text{rad/sec}$  and up the phase will be  $-270^\circ$  due to the plant's pole contribution. A line is drawn between  $0.289$  and  $28.9\text{rad/sec}$  with  $-135^\circ$  at  $2.89\text{rad/sec}$ .



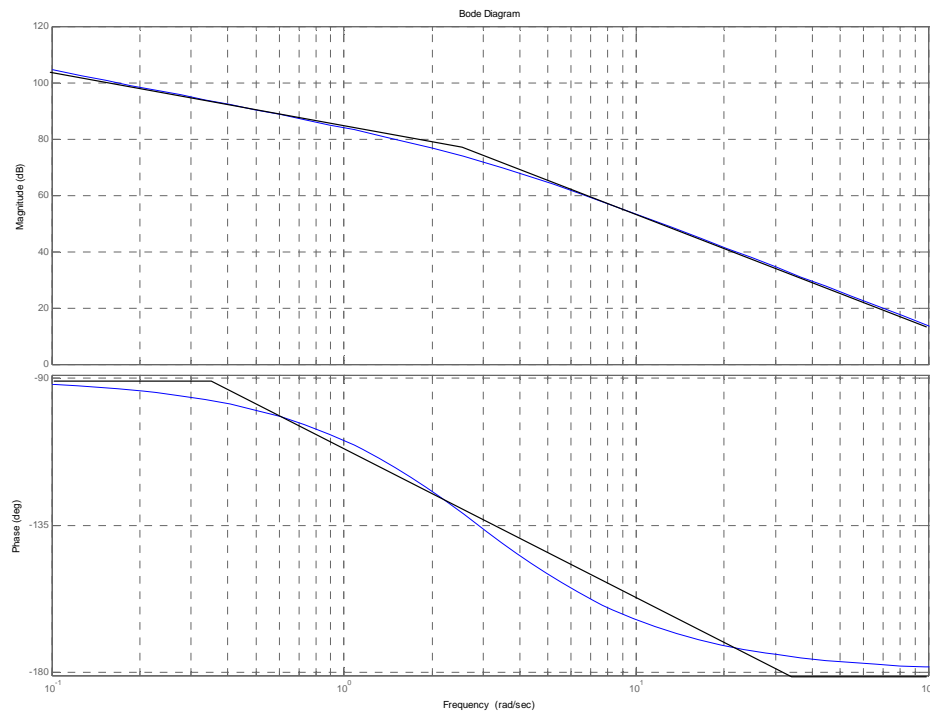

37.

- a. The frequency response  $P(j\omega) = \frac{1300}{\omega^2 + 860^2}$  is a real quantity. The Nyquist diagram is shown next. Since the open loop transfer function has one RHP pole,  $P=1$  and  $Z=P-N=1$  so the system will be closed loop unstable.

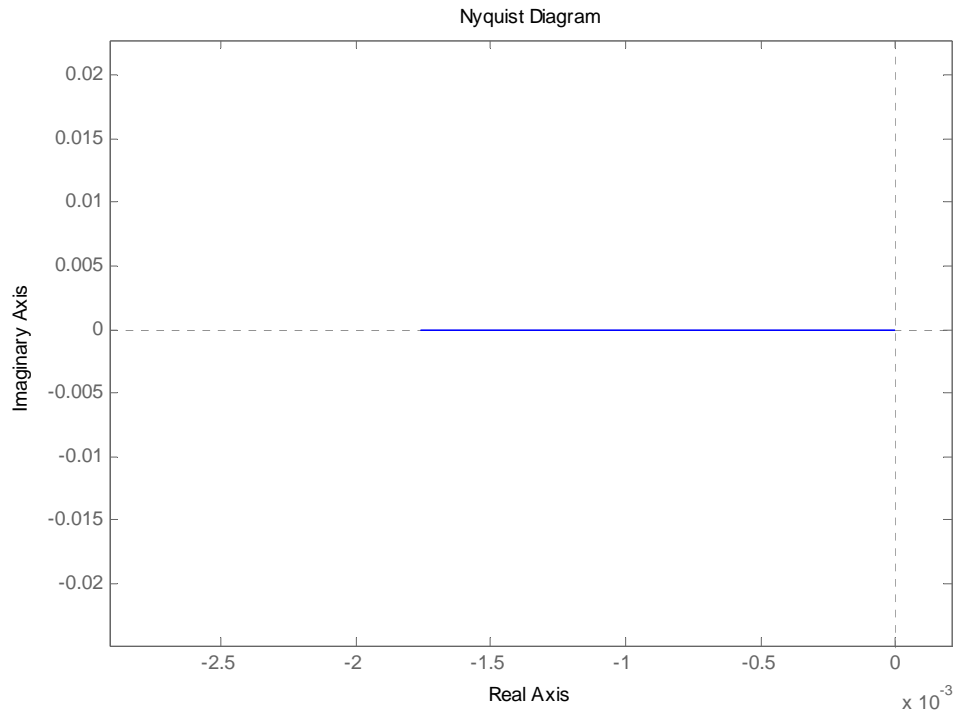

**b.** In this case for  $K = 1$  there are no encirclements of the -1 point so the system is closed loop unstable. However for large values of  $K$  there will be a negative encirclement of the -1 point so  $Z=P-N=0$  and the system is closed loop stable. The real axis crossover occurs at  $-3.5 \times 10^{-4}$  so the

range of stability is  $K > \frac{1}{3.5 \times 10^{-4}} = 2851$

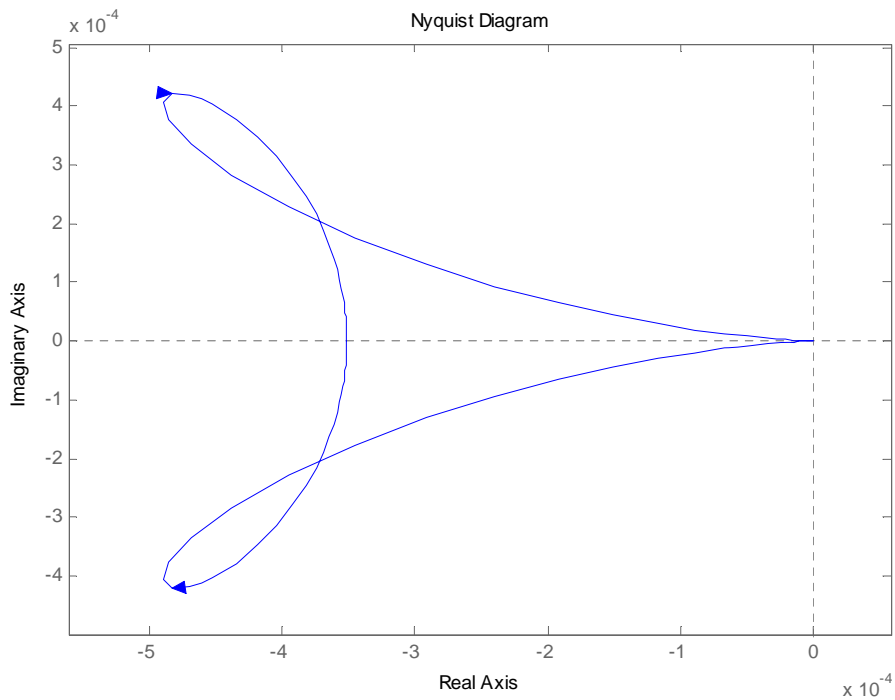

38.

The Nyquist diagram with  $K = 1$  is shown next.

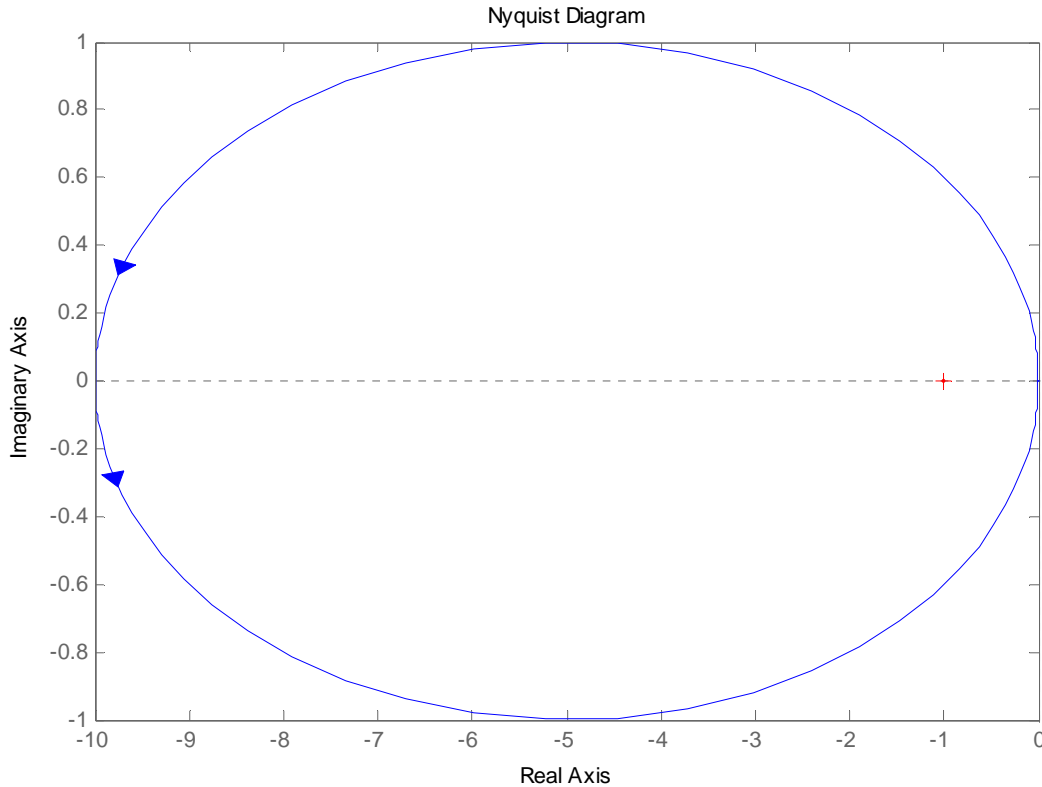

As shown the system is closed loop stable, since the system has one open loop RHP pole so  $P=1$ ,  $N=1$  and  $Z=P-N=1-1=0$ . Increasing the gain will not affect stability. However smaller  $K$  will eventually make the system unstable. As seen from the figure the system becomes marginally stable when  $K = 0.1$ . This system then is closed loop stable for  $0.1 < K < \infty$ .

39.

a. The Nichols Chart is shown below.

b. It can be seen there that  $M_p = 3\text{db} = 1.41$ . From figure 10.40 the  $\%OS \approx 35\%$ . From the Nichols chart, the phase margin is  $\Phi_M = 180^\circ - 136^\circ = 44^\circ$ , and from figure 10.48 in the text this corresponds to a  $\xi \approx 0.4$  damping ratio. It follows from figure 10.41a that since the open loop bandwidth is  $\omega_{BW} = 0.93 \frac{\text{rad}}{\text{sec}}$ , the settling time is  $T_s \approx \frac{15}{\omega_{BW}} = 16.1 \text{ sec}$ . The system is type 1 so  $c_{final} = 1$ .

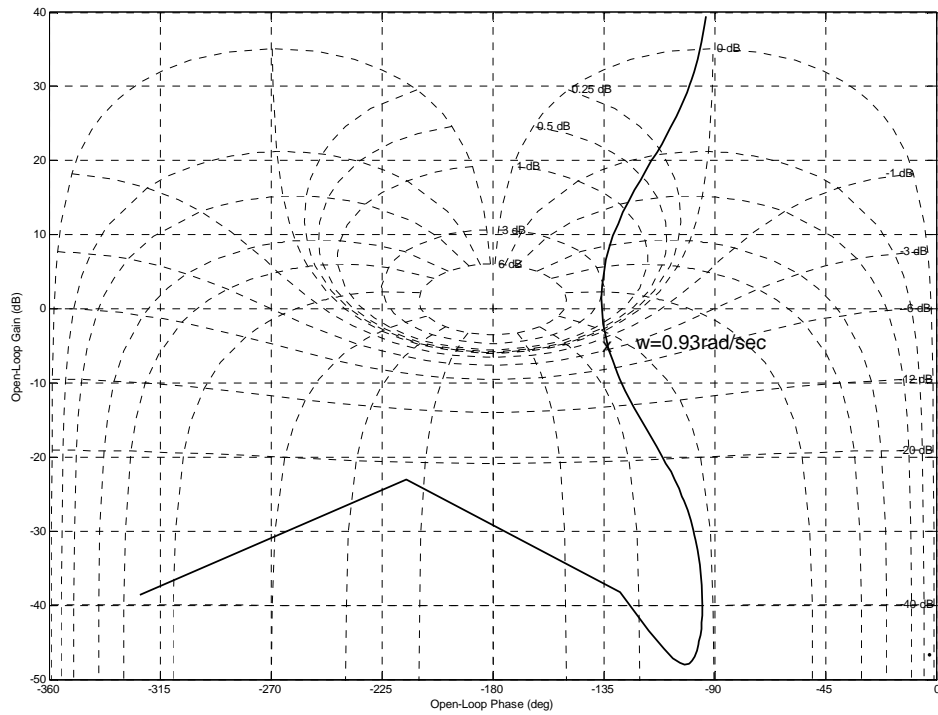

c.

```
>> syms s
```

```
>> s=tf('s');
```

```
>> P=0.63/(1+0.36*s/305.4+s^2/305.4^2)/(1+0.04*s/248.2+s^2/248.2^2);
```

```
>> G=0.5*(s+1.63)/s/(s+0.27);
```

```
>> L=G*P;
```

```
>> T=L/(1+L)
```

```
>> step(T)
```

It can be seen in the following figure that we slightly overestimated the %OS, but the settling time is close to the predicted.

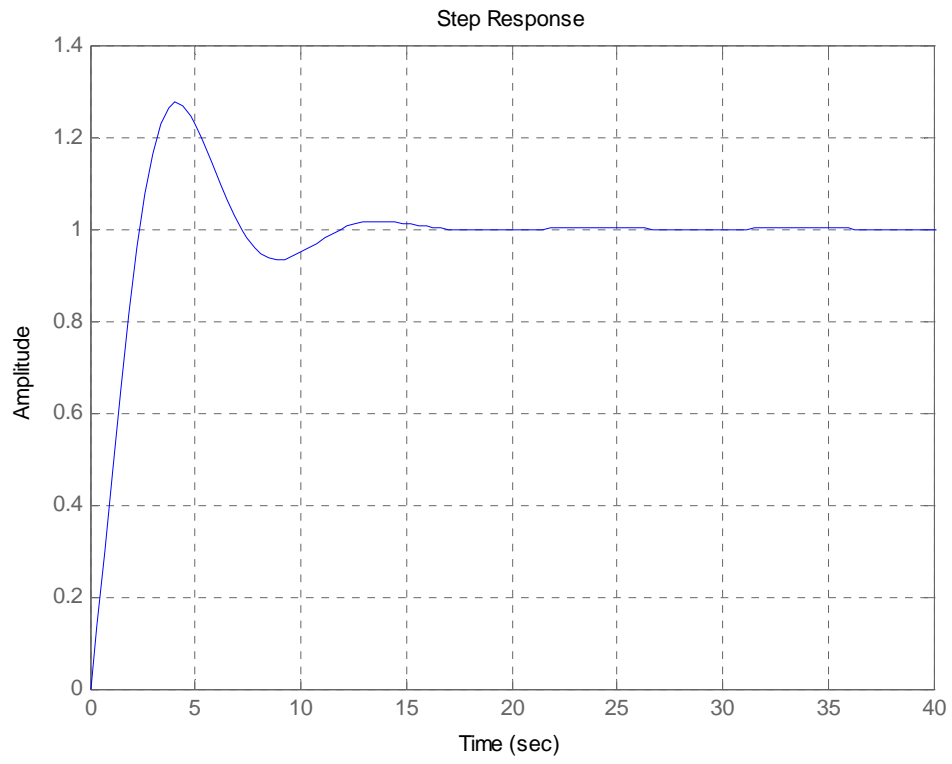

40.  
a.

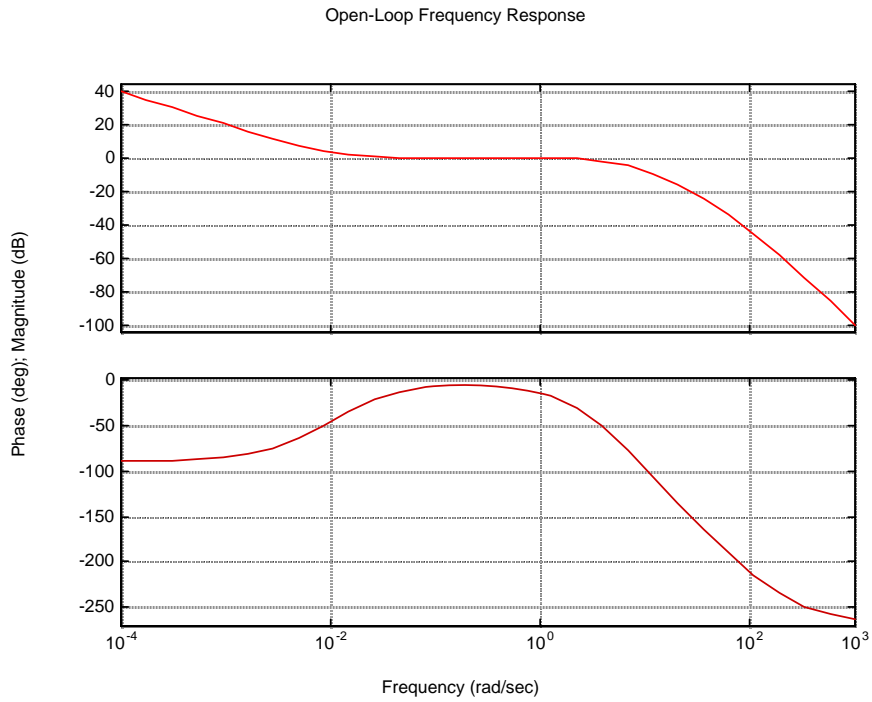

From the Bode plot: Gain margin = 29.52 dB; phase margin =  $157.5^\circ$ ; 0 dB frequency = 1.63 rad/s;  
 $180^\circ$  frequency = 49.8 rad/s.

b. System is stable since it has  $180^\circ$  of phase with a magnitude less than 0 dB.

41.  
a.

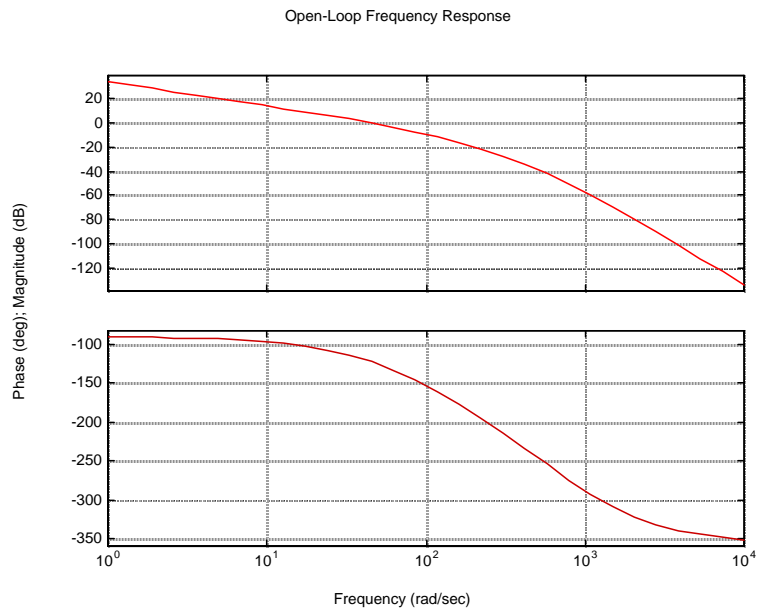

From the Bode plot: Gain margin = 17.1 dB; phase margin =  $57.22^{\circ}$ ; 0 dB frequency = 45.29 rad/s;  
180 $^{\circ}$  frequency = 169.03 rad/s; bandwidth(@-7 dB open-loop) = 85.32 rad/s.

b. From Eq. (10.73)  $\zeta = 0.58$ ; from Eq. (4.38) %OS = 10.68; from Eq. (10.55)  $T_s = 0.0949$  s; from Eq. (10.56)  $T_p = 0.0531$  s.

c.

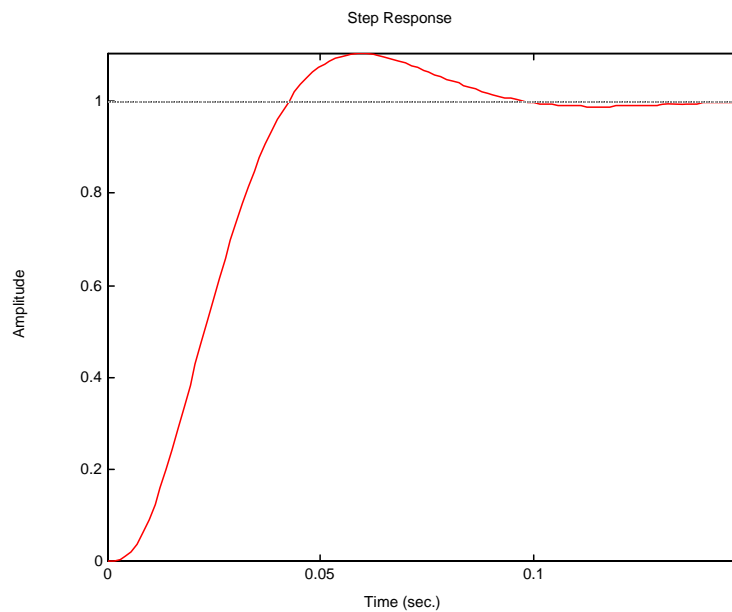

42.

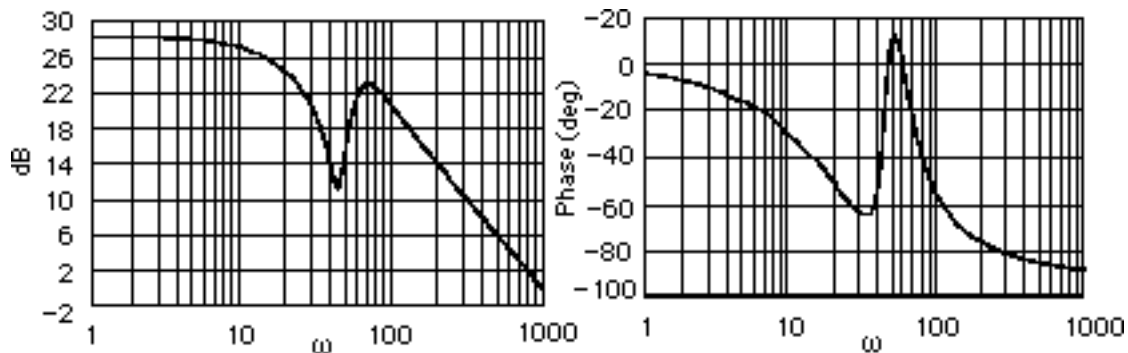

Resonance at 70 rad/s.

43.

$$G(s) = \frac{10}{s(s+2)(s+10)} . \text{ Plotting the Bode plots,}$$

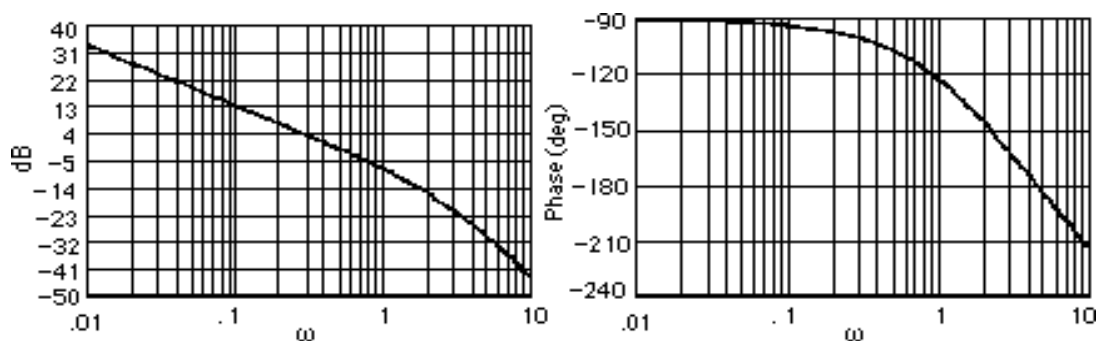

The gain is zero dB at 0.486 rad/s and the phase angle is  $-106.44^\circ$ . Thus, the phase margin is  $180^\circ - 106.44^\circ = 73.56^\circ$ . Using Eq. (10.73),  $\zeta = 0.9$ . Using Eq. (4.38), %OS = 0.15%.

44.

$$G(s) = \frac{22.5}{(s+4)(s^2+0.9s+9)} . \text{ Plotting the Bode plots,}$$

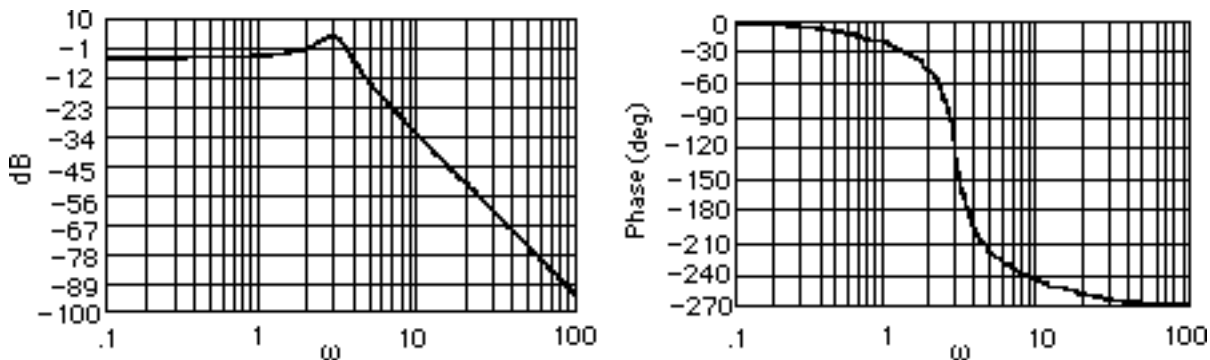



The phase response is  $180^\circ$  at  $\omega = 3.55$  rad/s, where the gain is  $-1.17$  dB. Thus, the gain margin is  $1.17$  dB. Unity gain is at  $\omega = 2.094$  rad/s, where the phase is  $-49.85^\circ$  and at  $\omega = 3.452$  rad/s, where the phase is  $-173.99^\circ$ . Hence the phase margin is measured at  $\omega = 3.452$  rad/s and is  $180^\circ - 173.99^\circ = 6.01^\circ$ . Using Eq. (10.73),  $\zeta = 0.0525$ . Eq. (4.38) yields  $\%OS = 84.78\%$ .

45.

a. The Nichols Chart, shown below, shows that for  $L = 1$  the system is closed loop unstable since the number of open loop RHP poles  $P=0$  and the chart crosses the  $-180^\circ$  line above the  $0$ db line.

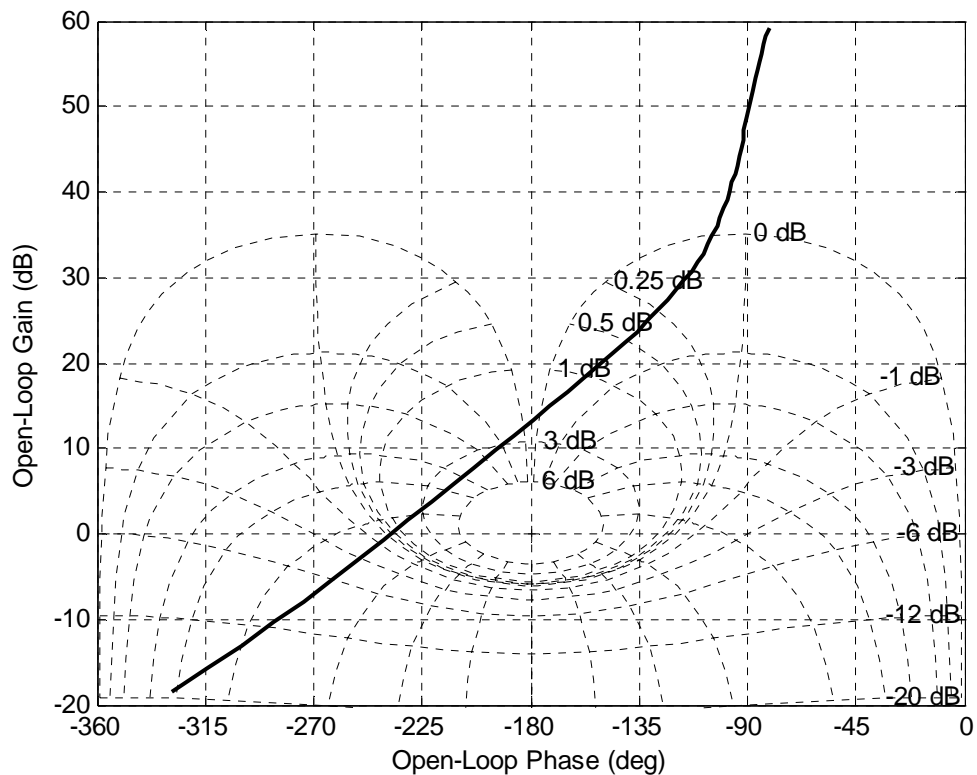

b. It can be observed from the diagram that the  $-180^\circ$  crossover occurs when

$$|L(j\omega)| = 13.25 \text{ db} = 4.5 \text{ so the closed loop stability range is } 0 < L < \frac{1}{4.5} = 0.221.$$

c. The Nichols Chart below shows that  $L(0) = G(0)P(0) \approx 58 \text{ db}$ , so for a unit step input

$$c_{final} \approx \frac{794.33}{1 + 794.33} = 0.998. \text{ Also } M_p \approx 6 \text{ db} = 2 \text{ which from figure 10.40 in the text}$$

corresponds to a  $\%OS=47\%$ . The phase margin is  $\Phi_M = 180^\circ - 148.5^\circ = 31.5^\circ$  so from figure

10.48 the corresponding damping factor is  $\zeta = 0.3$ . The open loop bandwidth is

$$\omega_{BW} = 2.5 \frac{\text{rad}}{\text{sec}} \text{ so from figure 10.41a } \omega_{BW} T_s \approx 20 \text{ and } T_s \approx 8 \text{ sec}$$

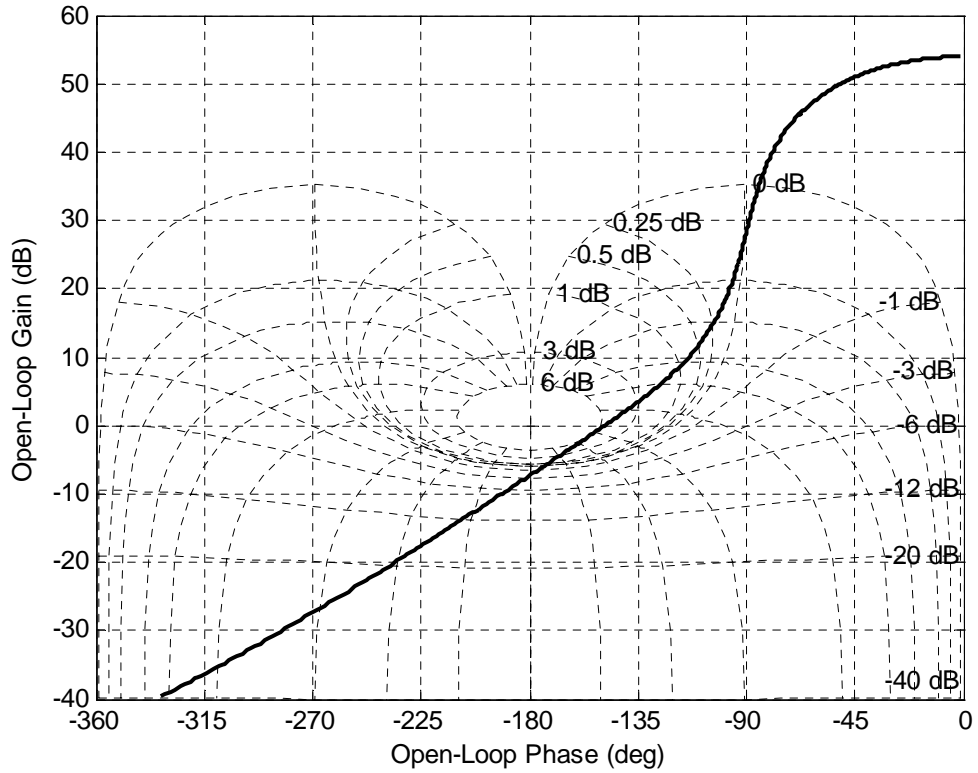

d.

The block diagram and simulation are:

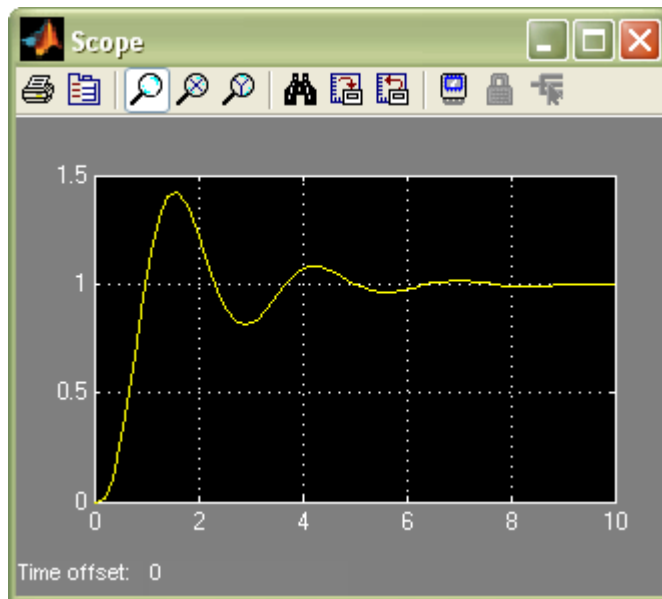
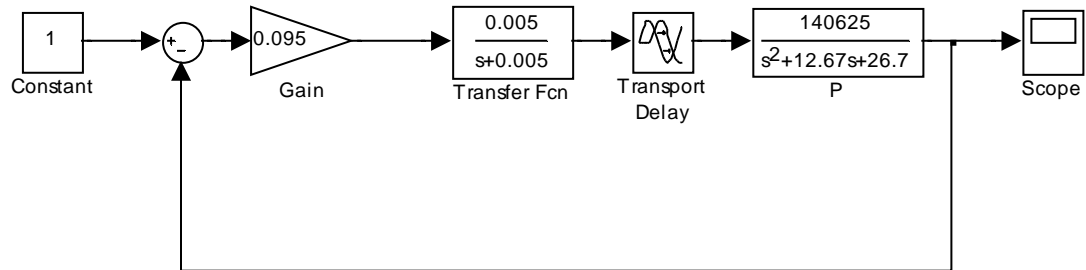

The simulation verifies the predictions.

46.  
 b. The Nyquist diagram is:

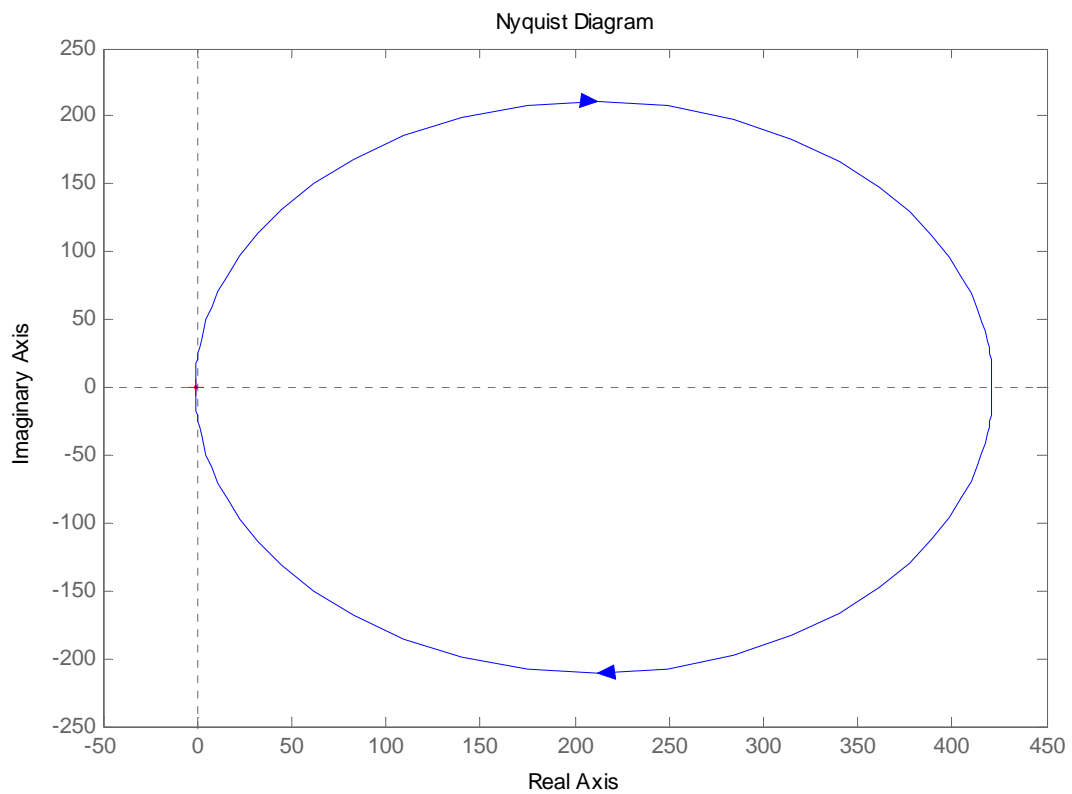

A closed view of the -1 point shows below that  $|L(j1.74)| = 1$  and  $\arg(L(j1.74)) = -132.8^\circ$  so

the phase margin without delay is  $\Phi_M = 180^\circ - 132.8^\circ = 47.2^\circ = 0.824\text{rad}$

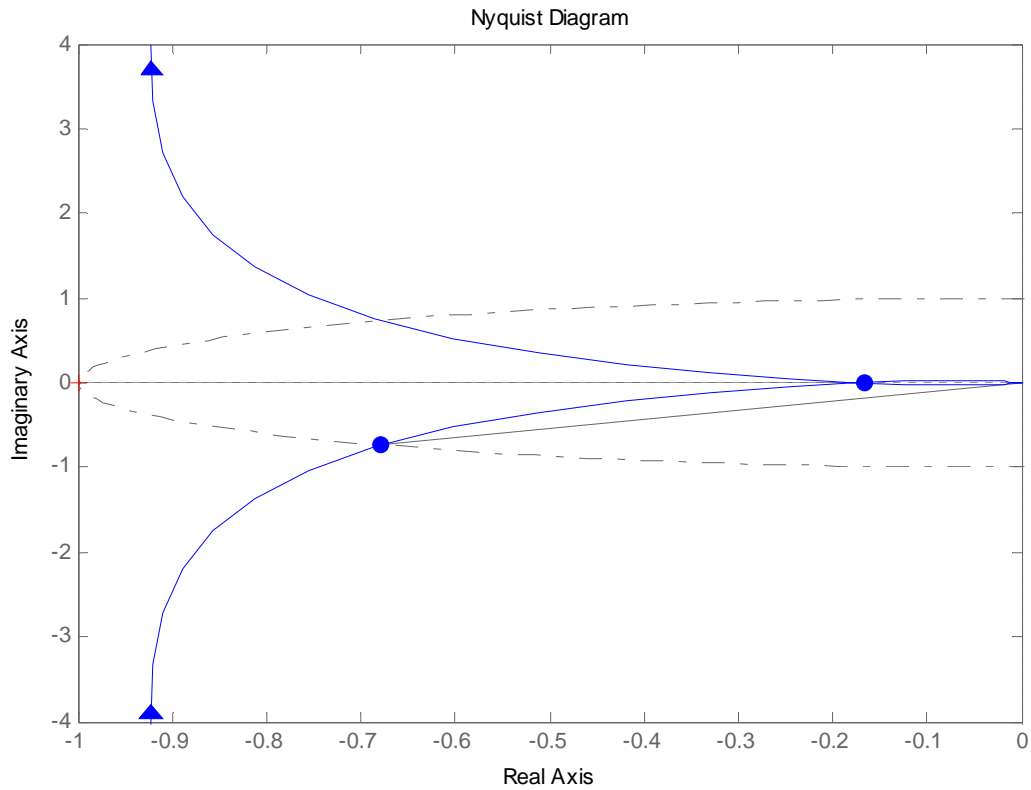

c. The maximum allowable time delay is obtained by noting solving  $1.74T < 0.824$  or  $T < 0.47 \text{ sec}$

47.

a.

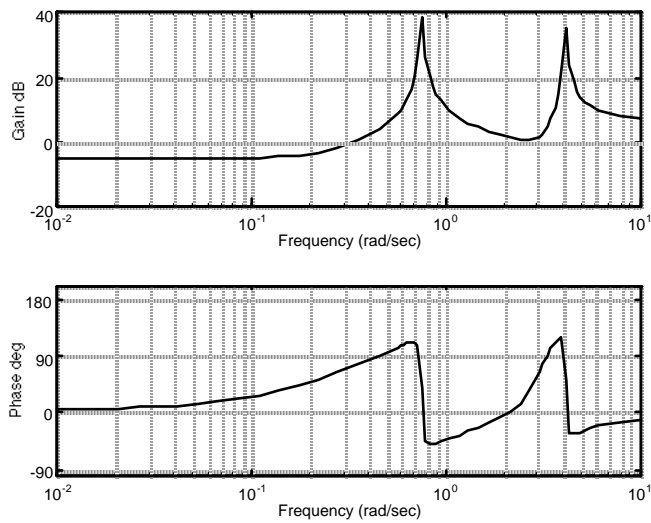

The frequencies that will be reduced occur at the peaks of the magnitude plot. The frequencies at the peaks are 4.14 rad/s and 0.754 rad/s.

b. Consider a system with a disturbance,  $R_d$  at the output of a system:

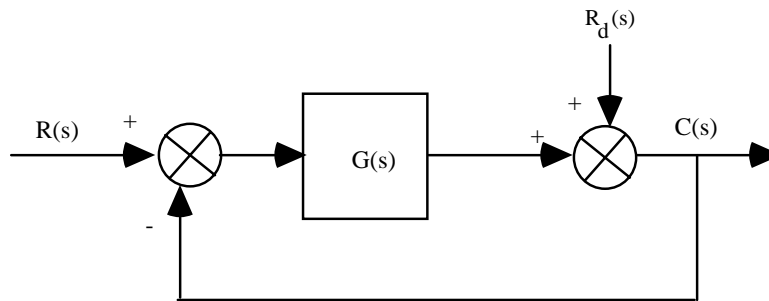

The transfer function relating  $C(s)$  to  $R_d(s)$  is  $\frac{C(s)}{R_d(s)} = \frac{1}{1 + G(s)}$ . Therefore,

$$C(s) = \frac{1}{1 + \frac{N_G}{D_G}} * \frac{N_{Rd}}{D_{Rd}} = \frac{D_G}{D_G + N_G} * \frac{N_{Rd}}{D_{Rd}}$$

Thus, if the poles of  $G(s)$  match the poles of  $R_d$  ( $D_G = D_{Rd}$ ) there will be cancellation and the dynamics of the disturbance will be reduced. Thus, if the dynamics of  $R_d$  is oscillation, add poles in cascade with  $G(s)$  that have the same dynamics. Since the poles yield large gain at these bending frequencies a zero is placed near the poles so that the filter will have minimal effect on the transient response (similar to placing a zero near a pole for a lag compensator). This arrangement of poles and zeros is called a dipole. Also note that a high gain at the bending frequency yields negative feedback for the output to subtract from  $R_d$ . Care should be exercised through analysis and simulation to be sure that the system's response to an input, other than the disturbance, is not adversely affected by the additional poles.

48.

a. The following code will generate the Nyquist diagram:

```
>> s=tf('s');
>> P=1.163e8/(s^3+962.5*s^2+5.958e5*s+1.16e8);
>> G=78.575*(s+436)^2/(s+132)/(s+8030);
>> L=G*P;
>> nyquist(L)
```

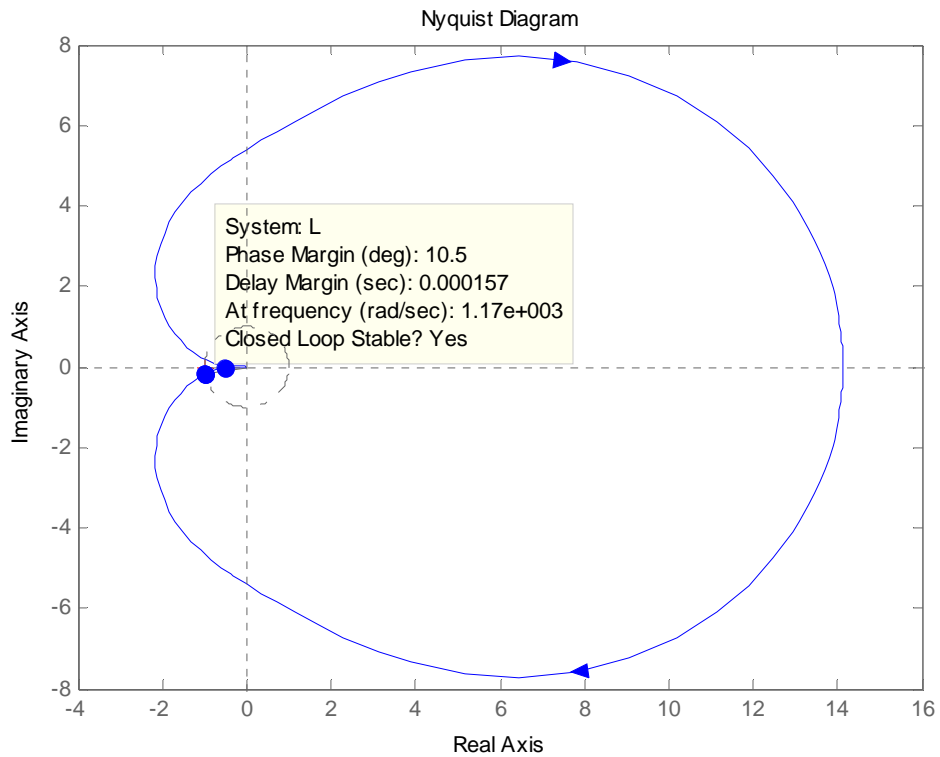

As seen in the figure the system is closed loop stable.

- b. It can be seen in the figure that the phase margin is 10.5 degrees.
- c. From Figure 10.48 in the text, a 10.5 degree phase margin corresponds approximately to a damping factor of 0.16. This in turn means that

$$\%OS = 100e^{-\frac{\xi\pi}{1-\xi^2}} = 60\%$$

- d. To simulate the response of the system to a unit step, we can use:  
`>> step(L/(1+L))`

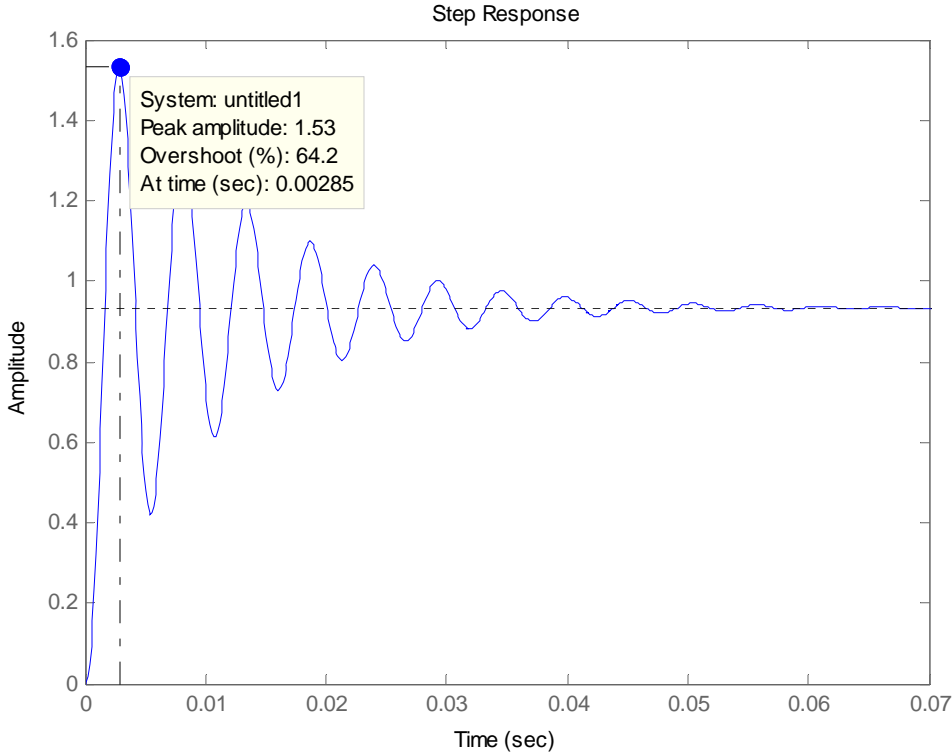

It can be seen that the actual overshoot is 64.2%.

49.

a. The Nyquist plot will approximately loop as follows (for positive  $\omega$ ):

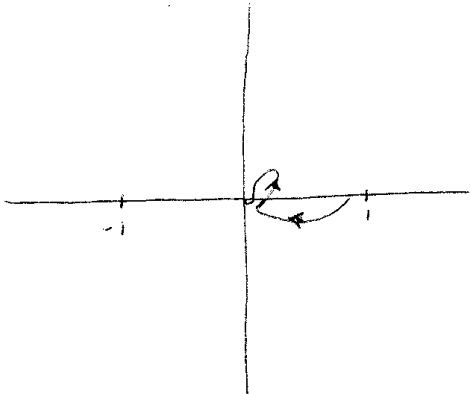

b. For  $K=1$ , it can be seen that there are no encirclements of the -1 point.



c. The system will be stable for  $0 < K < \infty$ , because the phase never exceeds -90 degrees, so there can be no encirclements of the -1 point.

50.

Front Panel and Block Diagram for “CDEx Nyquist Analysis.vi” (modified)

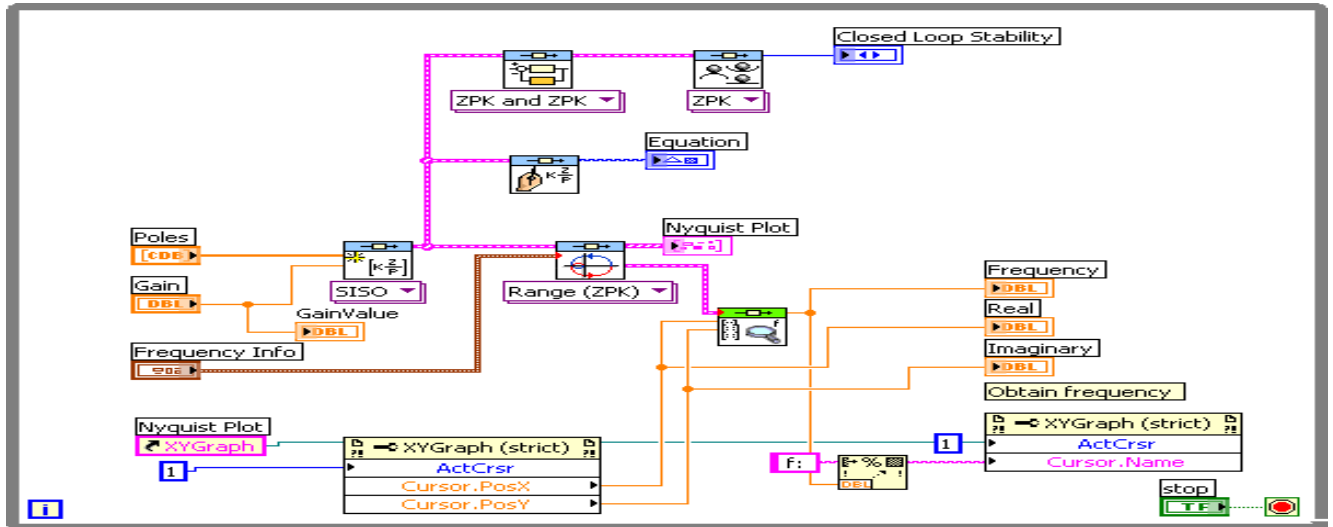
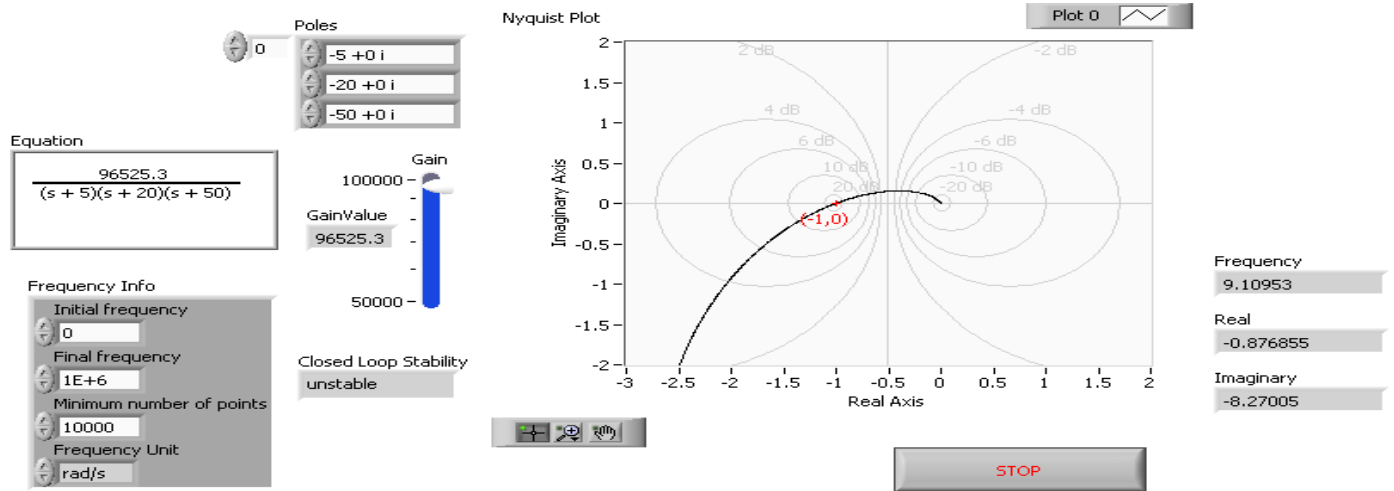

Front Panel and Block Diagram for Nyquist plot and frequency response data  
Front Panel

10-72 Chapter 10: Frequency Response Methods

ENTER OPEN LOOP NUMERATOR/DENOMINATOR POLYNOMIALS

Numerator

0 10000 0 0

Denominator

0 5000 1350 75 1

Gain Margin (db)

19.6802

Phasemargin (degrees)

92.9377

Frequency at 180 (rad/sec)

36.7669

Frequency at Zero db (rad/sec)

7.73551

Nyquist Plot

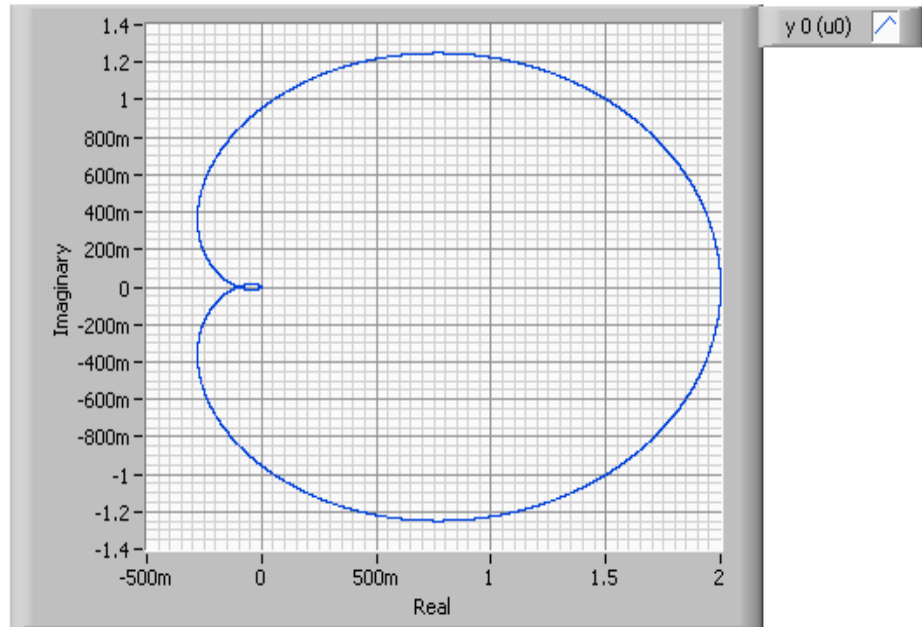

## Block Diagram

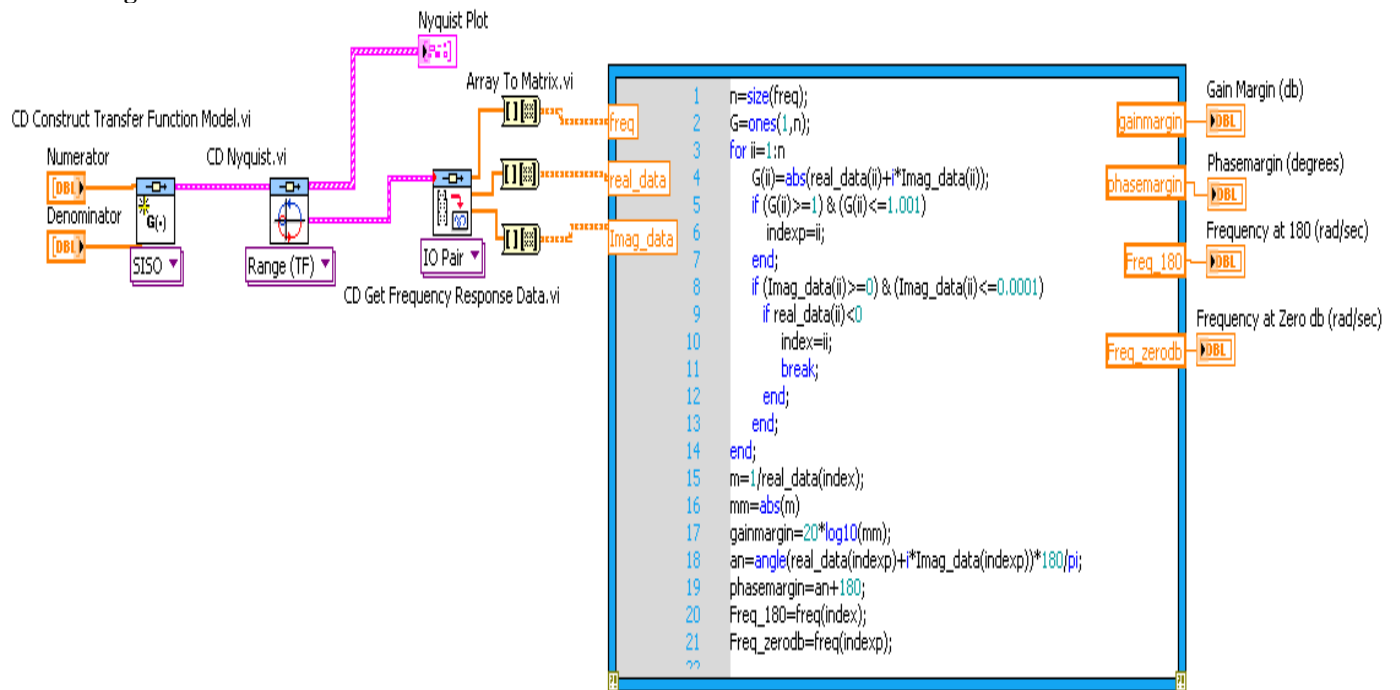

51.

Front Panel

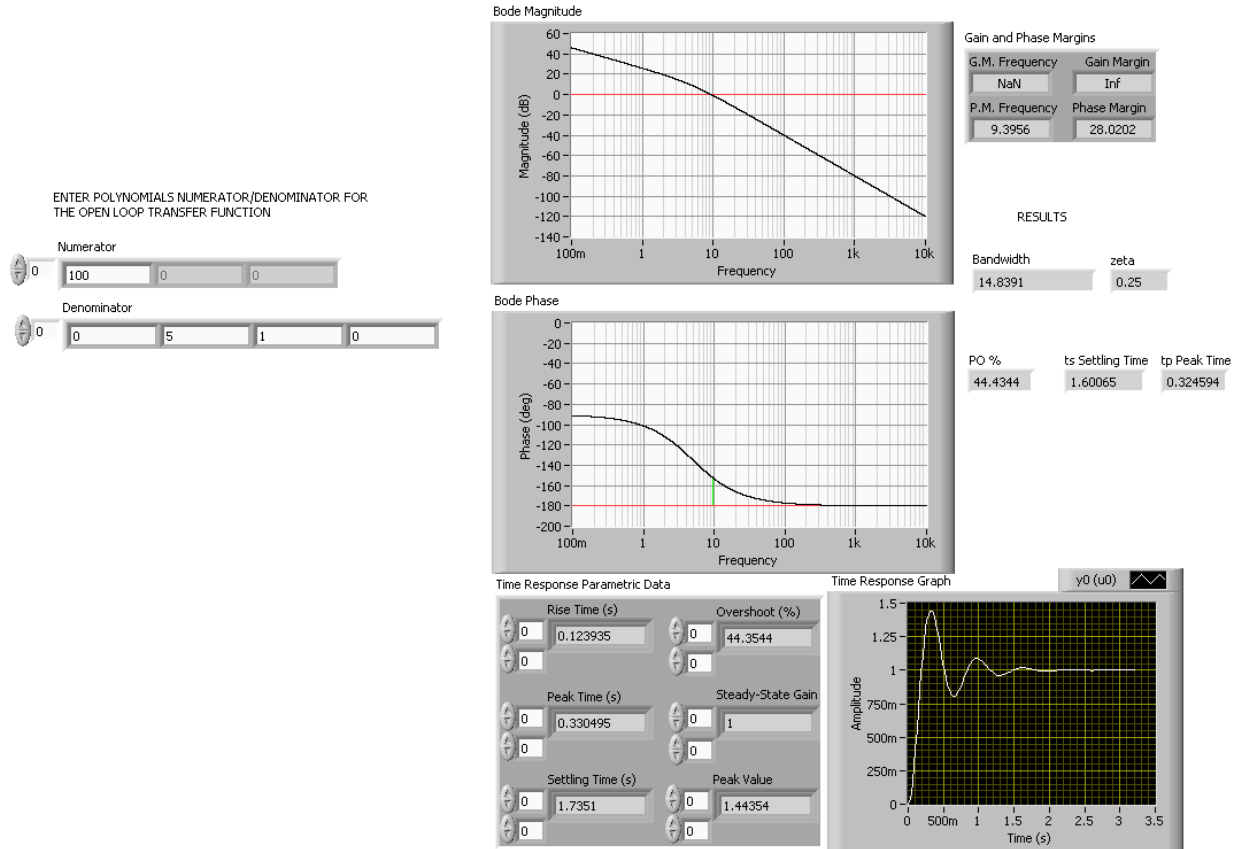

**Note:** Notice minor differences in estimating the transient domain specifications from the open loop frequency response with respect to the close loop parametric data. That is: PO% is 44.43% (44.35% from close loop data), settling time is 1.6 sec (1.7 secs from close loop data), and finally, peak time is 0.32 secs (0.33 secs from close loop data).

**Block Diagram**

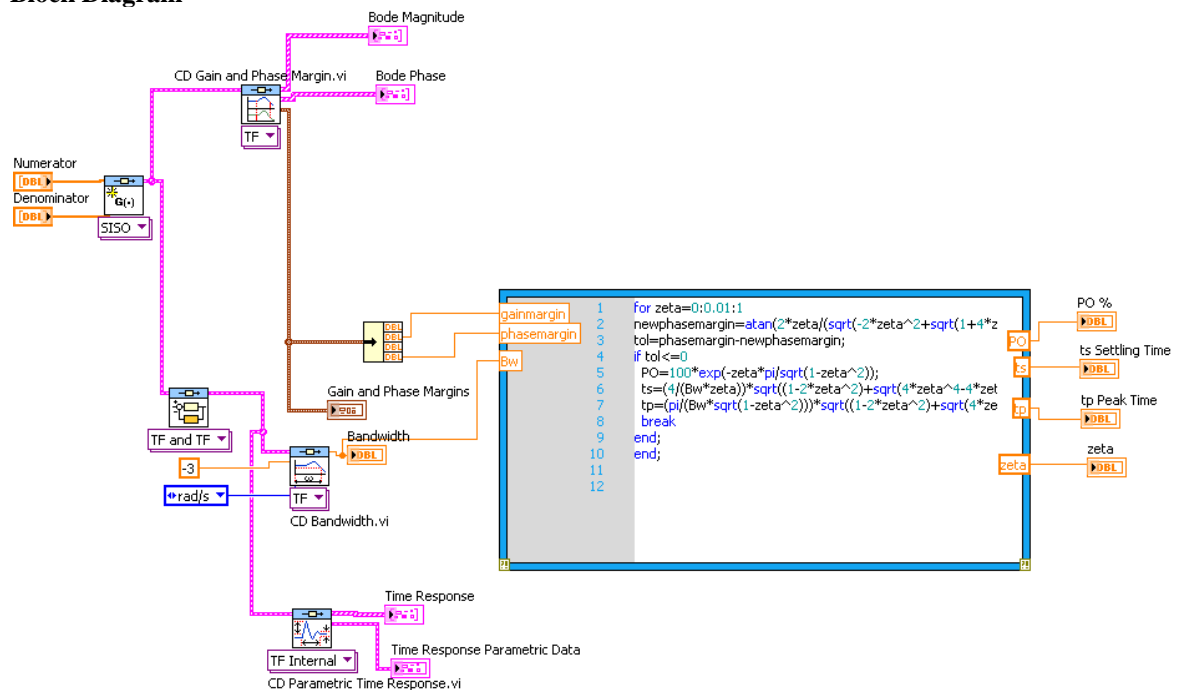

The details of the MathScript node code follow:

```

for zeta=0:0.01:1
newphasemargin=atan(2*zeta/(sqrt(-2*zeta^2+sqrt(1+4*zeta^4))))*(180/pi);
tol=phasemargin-newphasemargin;
if tol<=0
    PO=100*exp(-zeta*pi/sqrt(1-zeta^2));
    ts=(4/(Bw*zeta))*sqrt((1-2*zeta^2)+sqrt(4*zeta^4-4*zeta^2+2));
    tp=(pi/(Bw*sqrt(1-zeta^2)))*sqrt((1-2*zeta^2)+sqrt(4*zeta^4-4*zeta^2+2));
    break
end;
end;

```

52.

The following MATLAB file was used to plot the Bode magnitude and phase plots for that system and to obtain the response of the system,  $c(t)$ , at a pure delay of 1 second.

```

numg1 = conv([4 1], [10 1]); %numerator of G1 without pure delay
deng0 = conv([25 1],[3.333 1]); %the denominator without pure
integrator
deng1 = conv(deng0, [1 0]); %add pure integrator to denominator
G1 = tf(numg1, deng1); %G1 is the open-loop TF without pure
delay
[numd,dend]= pade(1,5); %5th-order Pade approximation of
pure delay
D = (tf (numd, dend));
G = G1*D;
Bode(G);
grid
pause
T = feedback(G,1); %C.L. TF of the PD_compensated system
T = minreal(T);
step(T);
grid
xlabel ('Time')
ylabel ('Controlled Level, c(t) in p. u.')
title ('Unit Step Response of Water Level in the Steam generator ')

```

- a. The Bode magnitude and phase plots for this system, obtained using fifth-order Pade approximation for  $\tau = 1$  sec, are shown below with minimum stability margins displayed.

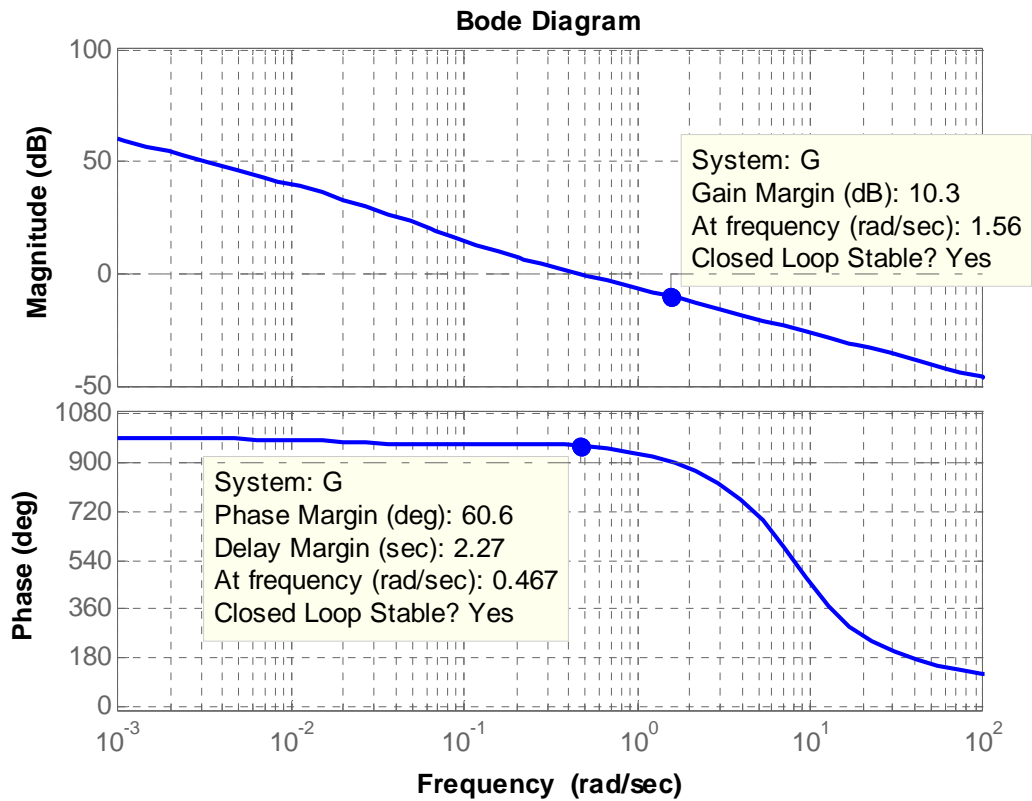

- b.** The response of the system,  $c(t)$ , to a unit step input,  $r(t) = u(t)$ , is shown below for  $\tau = 1$  sec. The rise time,  $T_r$ , the settling time,  $T_s$ , the final value of the output, percent overshoot,  $\%OS$ , and peak time,  $T_p$ , are displayed.

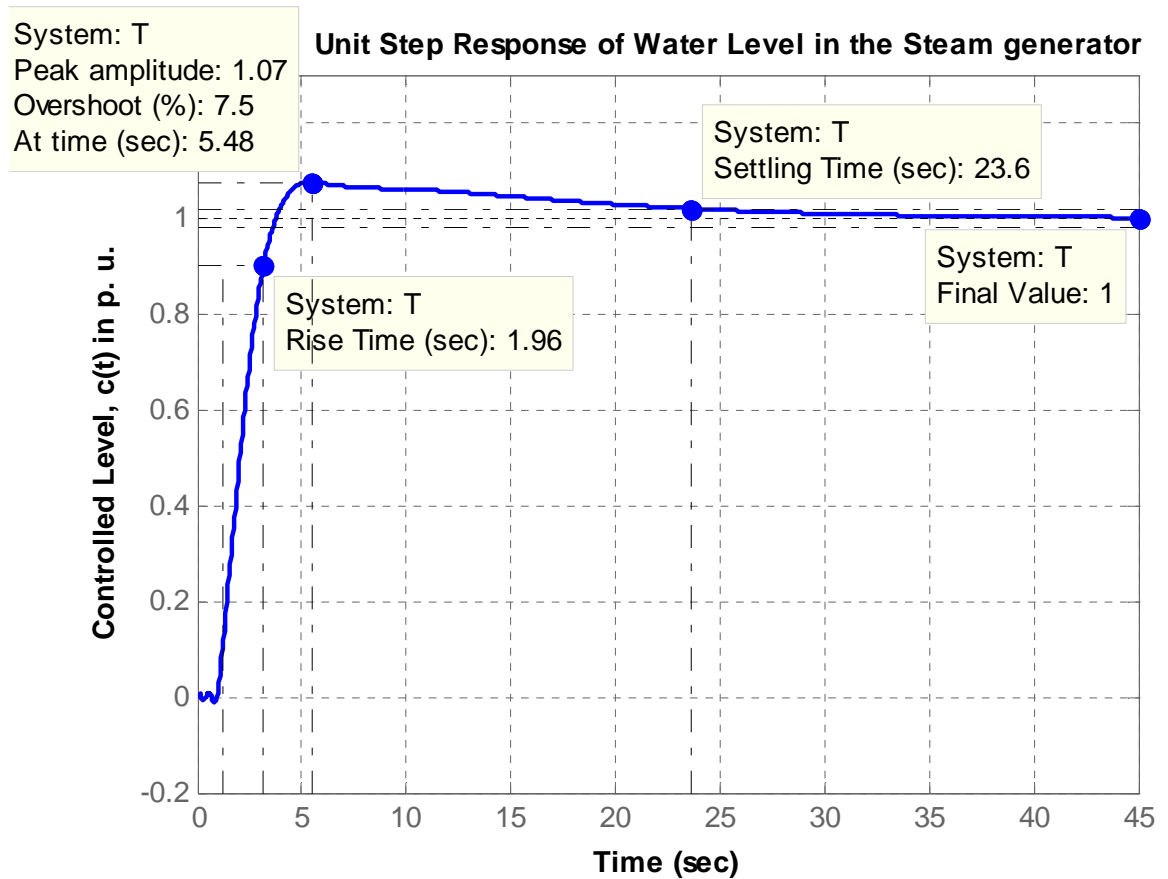

- c. The Bode magnitude and phase plots for this system for a pure delay  $\tau = 1.5$  seconds, are shown below with minimum stability margins displayed.

Also shown below is the response of the system,  $c(t)$ , to a unit step input,  $r(t) = u(t)$ , for a pure delay  $\tau = 1.5$  seconds. The rise time,  $T_r$ , the settling time,  $T_s$ , the final value of the output, percent overshoot,  $\%OS$ , and peak time,  $T_p$ , are displayed on the graph.

Note that the percent overshoot increased from 7.5% to 27.6% as the delay time increased from 1 to 1.5 seconds.

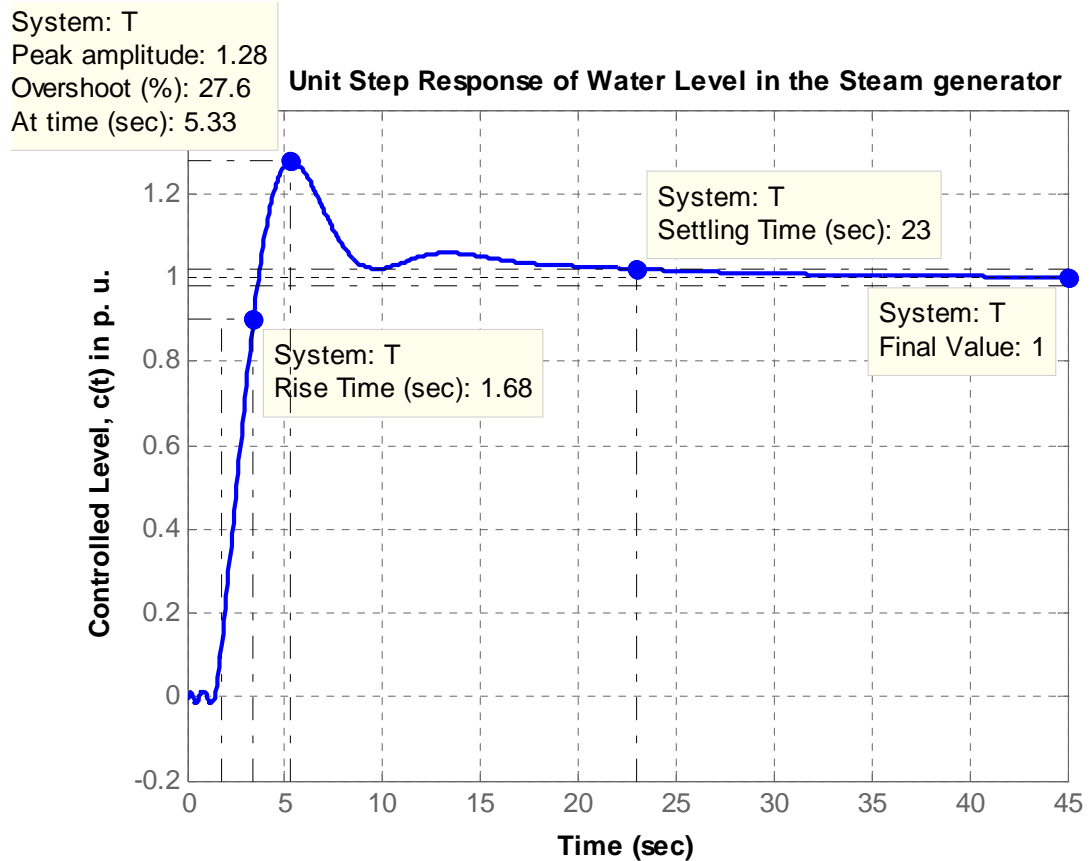
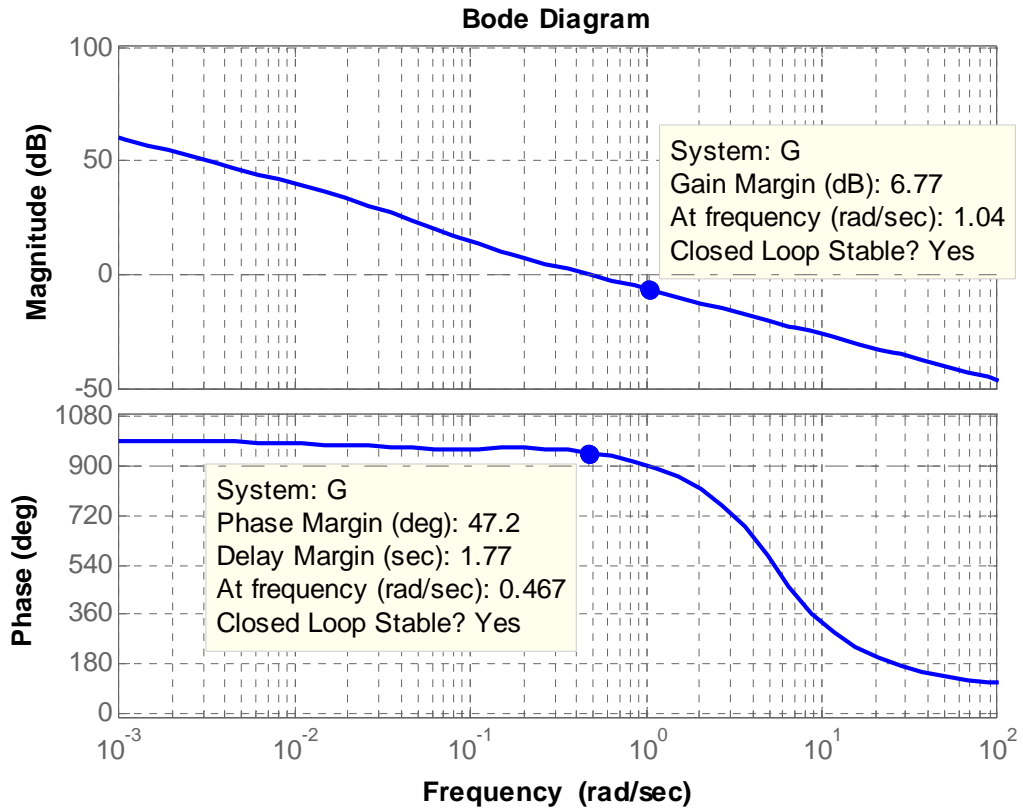



53.

a. From Chapter 8,

$$G_c(s) = \frac{0.6488K (s+53.85)}{(s^2 + 8.119s + 376.3) (s^2 + 15.47s + 9283)}$$

Cascading the notch filter,

$$G_{et}(s) = \frac{0.6488K (s+53.85)(s^2 + 16s + 9200)}{(s^2 + 8.119s + 376.3) (s^2 + 15.47s + 9283)(s+60)^2}$$

Plotting the Bode plot,

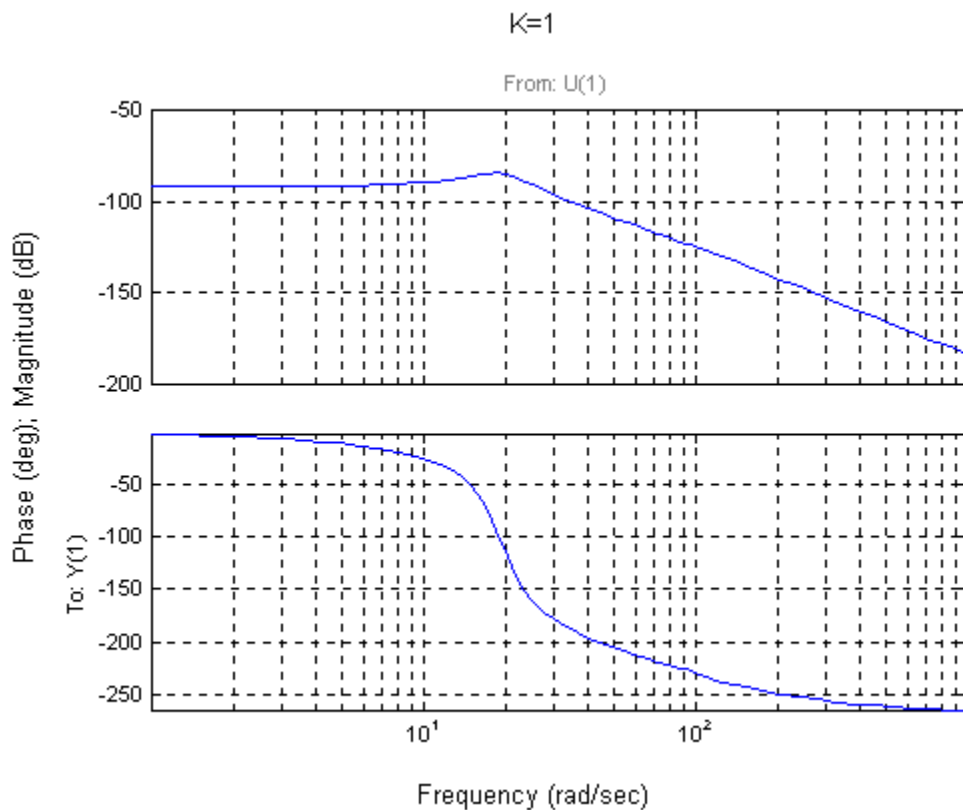

From the Bode plot: Gain margin = 96.74 dB; phase margin =  $\infty$ ; 0 dB frequency = N/A; 180° frequency = 30.44 rad/s.

b.  $K = 96.74 \text{ dB} = 68732$ c. In Chapter 6  $K = 188444$ . The difference is due to the notch filter.

54.

a. A bode plot of the open loop transmission  $G_c(s)P(s)$  shows that the open loop transfer function has a crossover frequency of  $\omega_c = 0.04 \frac{rad}{day}$ . A convenient range for sampling periods is

$$3.75day = \frac{0.15}{\omega_c} < T < \frac{0.5}{\omega_c} = 12.5day . T=8 \text{ days fall within range.}$$

b. We substitute  $s = \frac{1}{4} \frac{z-1}{z+1}$  into  $G_c(s)$  we get

$$G_c(z) = \frac{-2 \times 10^{-4} (1.145z^2 - 1.71z + 0.8489)}{z^2 - 1.852z + 0.8519}$$

c.

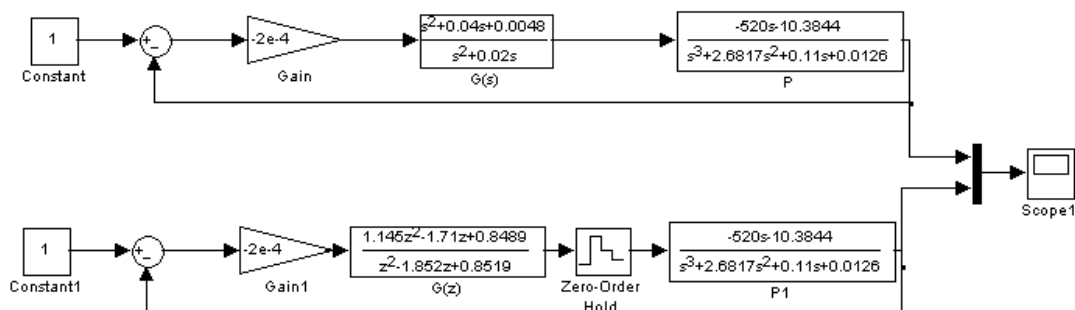

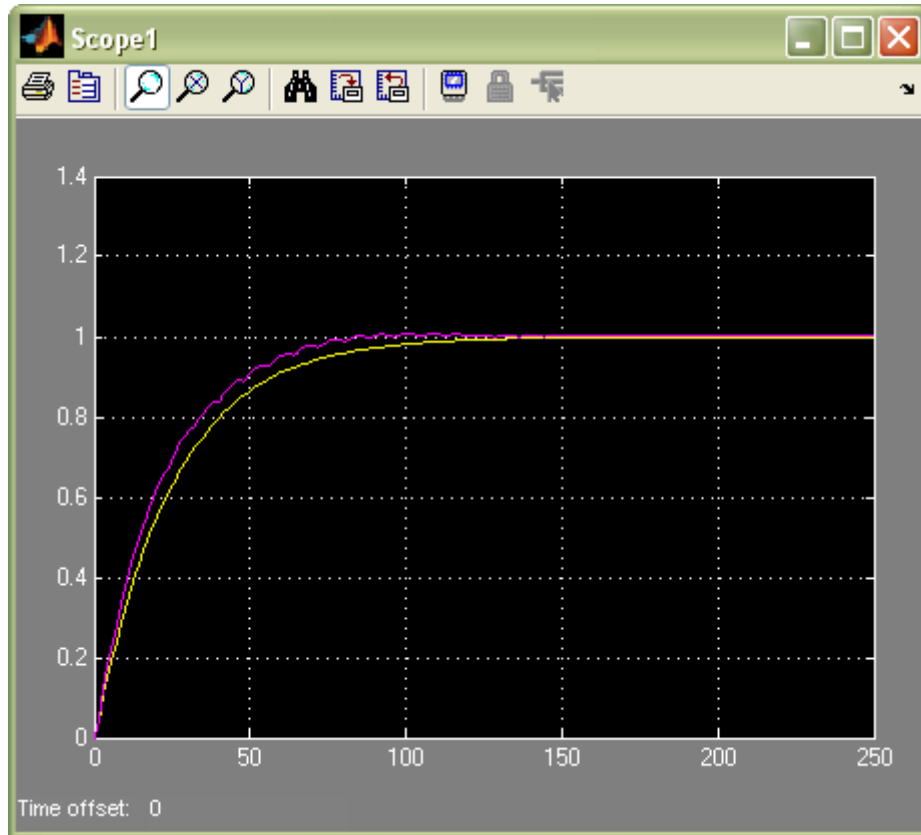

55.

**a.**

The following MATLAB file was used to plot the Bode magnitude and phase plots for that system and to obtain the response of the system,  $c(t)$ , to a step input,  $r(t) = 4 u(t)$ .

```

K = 0.78;
numg = K*[1 0.6];
deng = poly([-0.0163 -0.5858]);
G = tf(numg, deng);
bode(G);
grid
pause
T = feedback(G,1); %T is the closed-loop TF of the P_controlled
system
T = minreal(T);
step(4*T);
grid

```

```

xlabel ('Time')
ylabel ('Speed Sensor Output, c(t) in volts')
title ('P-controlled Systems Response to a 4 volt Input Step')

```

The Bode magnitude and phase plots obtained are shown below with the minimum stability margins displayed on the phase plot.

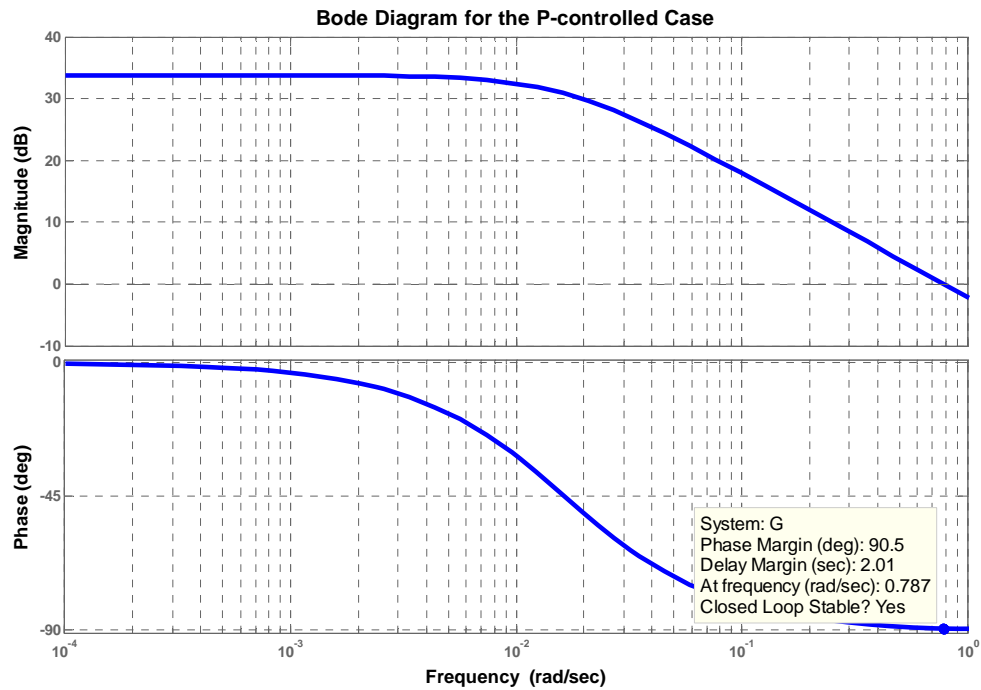

The response of the system,  $c(t)$ , to a step input,  $r(t) = 4 u(t)$  is shown below. The rise time,  $T_r$ , settling time,  $T_s$ , and the final value of the output are noted.

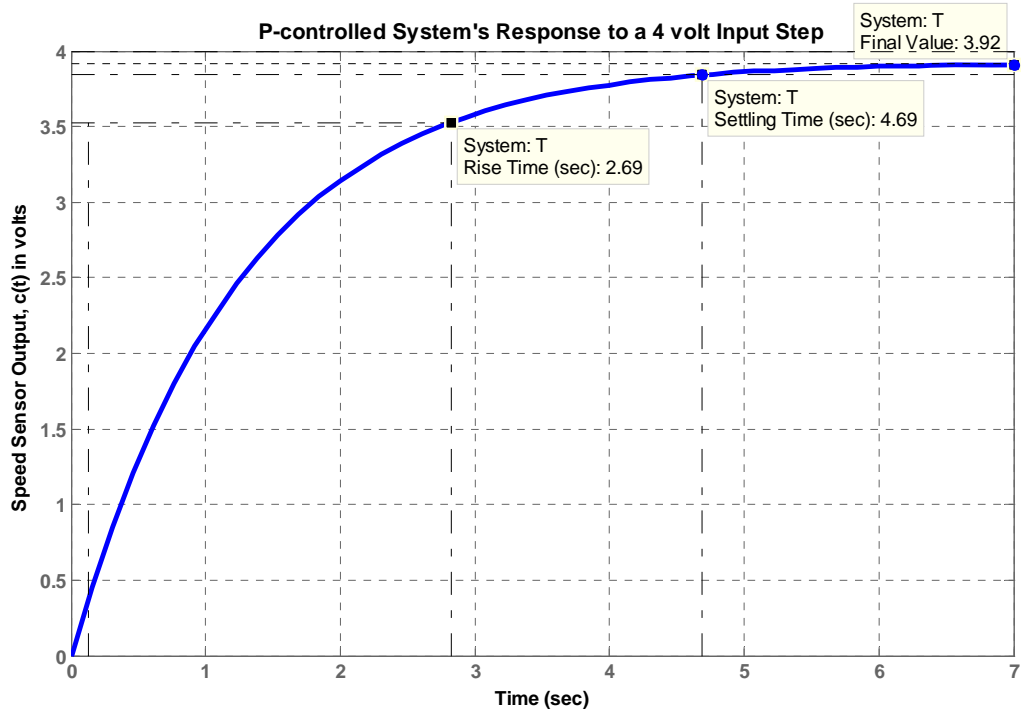

**b.**

After adding the integral gain to the controller, we substituted the values of  $K_1 = 0.78$  and

$Z_c = \frac{K_2}{K_1} = 0.4$  into the transfer function of the plant and compensator. Thus we obtained:

$$G(s) = \frac{0.78 \times (s+0.4)(s+0.6)}{s(s+0.5858)(s+0.0163)} = \frac{0.78s^2 + 0.78s + 0.1872}{s(s+0.5858)(s+0.0163)}$$

The following MATLAB file was written to plot the Bode magnitude and phase plots for that system and to obtain the response of the system,  $c(t)$ , to a step input,  $r(t) = 4 u(t)$ .

```
numg = [0.78 0.78 0.1872];
deng = poly([0 -0.0163 -0.5858]);
G = tf(numg, deng);
bode(G);
grid
pause
T = feedback(G,1); %T is the closed-loop TF of the PI-controlled
system
T = minreal(T);
step(4*T);
grid
xlabel('Time')
ylabel('Speed Sensor Output, c(t) in volts')
title('PI-controlled Systems Response to a 4 volt Input Step')
```

The Bode magnitude and phase plots obtained are shown below with the minimum stability margins displayed on the phase plot.

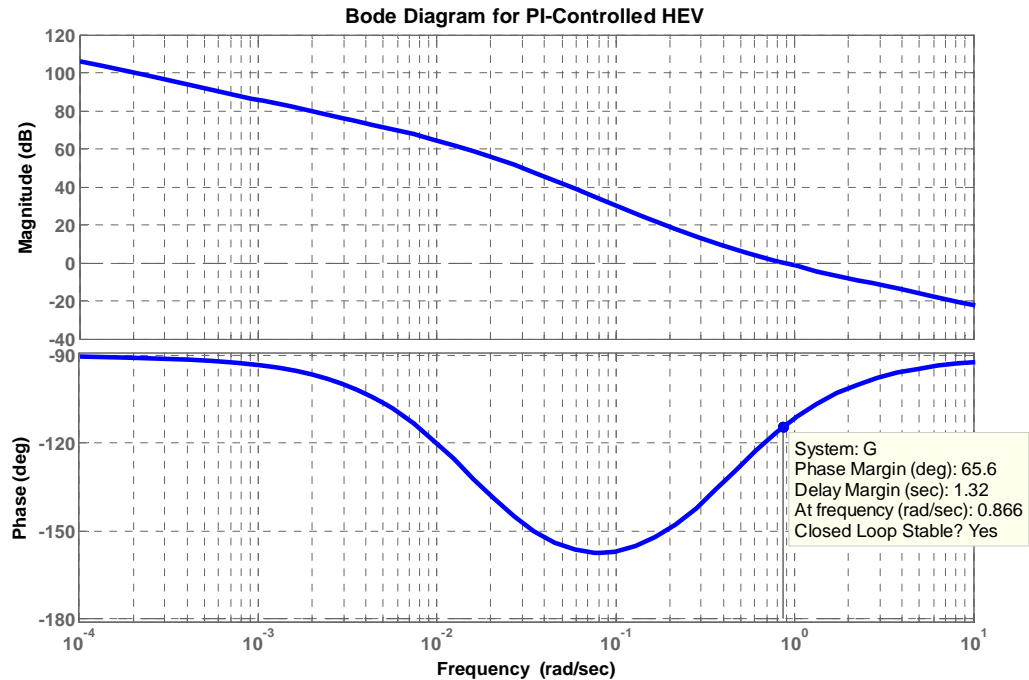

The response of the system,  $c(t)$ , to a step input,  $r(t) = 4 u(t)$  is shown below. The rise time,  $T_r$ , settling time,  $T_s$ , percent overshoot,  $\%OS$ , peak time,  $T_p$ , settling time,  $T_s$ , and the final value of the output are noted.

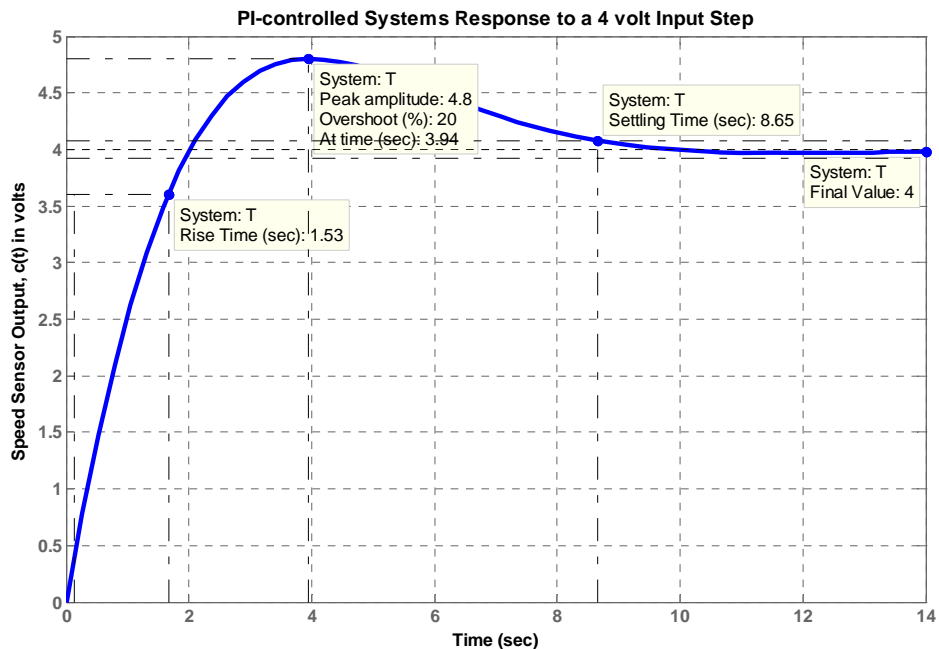

**c.**

The response obtained in (a), e.g. in the case of proportionally-controlled HEV, is closer to that of a first-order system rather than a critically-damped second order system. Note also that the Bode magnitude plot has a final slope of  $-20$  dB/dec and the phase plot has a final value of  $90^\circ$ .

The response obtained in (b), e.g. in the case of PI-controlled HEV, does not resemble well that of a second-order underdamped response. It should be noted, that one of the closed-loop poles (located at  $-0.5753$ ) is quite close to one of the closed-loop zeros (located at  $-0.6$ ) whereas the second closed-loop zero (located at  $-0.4$ ) is almost equal to the real part of the complex-conjugate dominant poles (located at  $-0.4034 \pm j 0.4034$ ).

# E L E V E N

## Design via Frequency Response

### SOLUTIONS TO CASE STUDIES CHALLENGES

#### Antenna Control: Gain Design

a. The required phase margin for 25% overshoot ( $\zeta = 0.404$ ), found from Eq. (10.73), is  $43.49^\circ$ .

From the solution to the Case Study Challenge problem of Chapter 10,  $G(s) = \frac{50.88K}{s(s+1.32)(s+100)}$ .

Using the Bode plots for  $K = 1$  from the solution to the Case Study Challenge problem of

Chapter 10, we find the required phase margin at  $\omega = 1.35$  rad/s, where the magnitude response is -14 dB. Hence,  $K = 5.01$  (14 dB).

b.

#### Program:

```
%Input system
numg=50.88;
deng=poly([0 -1.32 -100]);
G=tf(numg,deng);
%Percent Overshoot to Damping Ratio to Phase Margin
Po=input('Type %OS ');
z=(-log(Po/100))/(sqrt(pi^2+log(Po/100)^2));
Pm=atan(2*z/(sqrt(-2*z^2+sqrt(1+4*z^4))))*(180/pi);
fprintf('\nPercent Overshoot = %g',Po)
fprintf(', Damping Ratio = %g',z)
fprintf(', Phase Margin = %g',Pm)
%Get Bode data
bode(G)
pause
w=0.01:0.05:1000;%Step size can be increased if memory low.
[M,P]=bode(G,w);
M=M(:,:);
P=P(:,:);
Ph=-180+Pm;
for i=1:length(P);
if P(i)-Ph<=0;
M=M(i);
K=1/M;
fprintf(', Frequency = %g',w(i))
fprintf(', Phase = %g',P(i))
fprintf(', Magnitude = %g',M)
fprintf(', Magnitude (dB) = %g',20*log10(M))
fprintf(', K = %g',K)
break
end
end
T=feedback(K*G,1);
step(T)
```



**Computer response:**

Type %OS 25

Percent Overshoot = 25, Damping Ratio = 0.403713, Phase Margin = 43.463,  
 Frequency = 1.36, Phase = -136.634, Magnitude = 0.197379, Magnitude (dB)  
 = -14.094, K = 5.06641

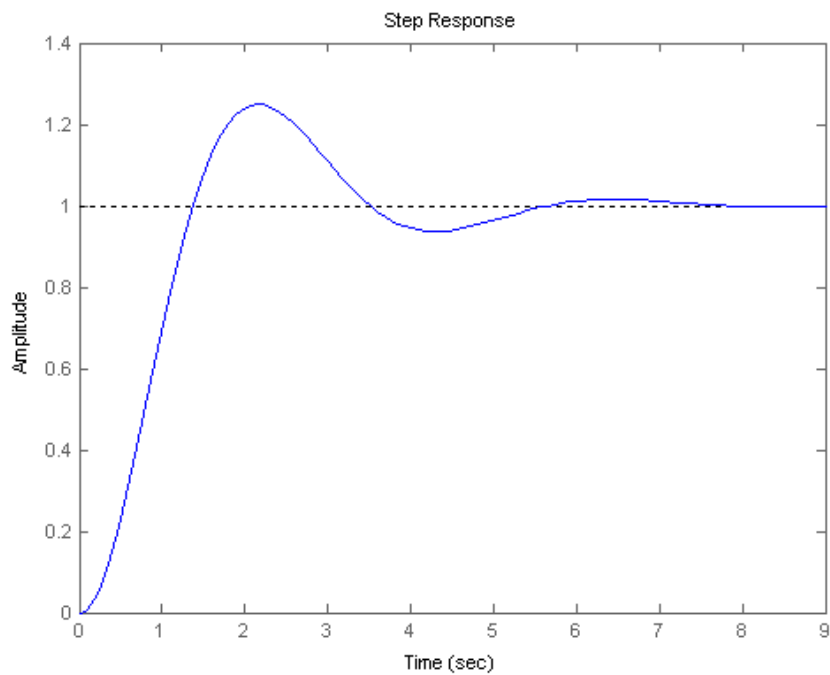
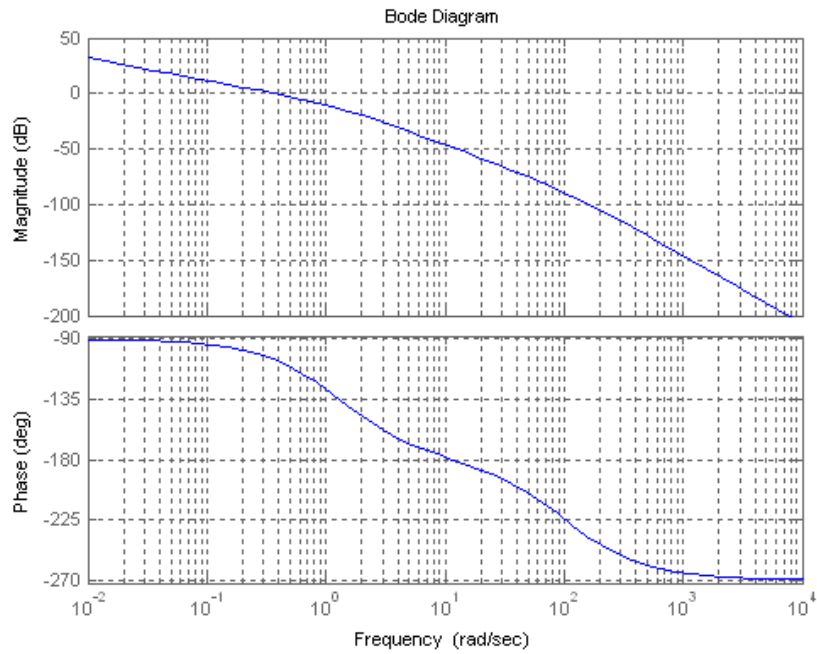

## Antenna Control: Cascade Compensation Design

a. From the solution to the previous Case Study Challenge in this chapter,  $G(s) = \frac{50.88K}{s(s+1.32)(s+100)}$ .

For  $K_v = 20$ ,  $K = 51.89$ . Hence, the gain compensated system is

$$G(s) = \frac{2640.16}{s(s+1.32)(s+100)}$$

Using Eq. (10.73), 15% overshoot (i.e.  $\zeta = 0.517$ ) requires a phase margin of  $53.18^\circ$ . Using the Bode plots for  $K = 1$  from the solution to the Case Study Challenge problem of Chapter 10, we find the required phase margin at  $\omega = 0.97$  rad/s where the phase is  $-126.82^\circ$ .

To speed up the system, we choose the compensated phase margin frequency to be  $4.6 * 0.97 = 4.46$  rad/s. Choose the lag compensator break a decade below this frequency, or  $\omega = 0.446$  rad/s.

At the phase margin frequency, the phase angle is  $-166.067^\circ$ , or a phase margin of  $13.93^\circ$ . Using 5° leeway, we need to add  $53.18^\circ - 13.93^\circ + 5^\circ = 44.25^\circ$ . From Figure 11.8,  $\beta = 0.15$ , or  $\gamma = \frac{1}{\beta} =$

6.667. Using Eq. (11.15), the lag portion of the compensator is

$$G_{\text{Lag}}(s) = \frac{(s+0.446)}{\frac{0.446}{6.667}} = \frac{s+0.446}{s+0.0669}$$

Using Eqs. (11.9) and (11.15),  $T_2 = \frac{1}{\omega_{\text{max}} \sqrt{\beta}} = 0.579$ . From Eq. (11.15), the lead portion of the compensator is

$$G_{\text{Lead}}(s) = \frac{s+1.727}{s+11.51}$$

The final forward path transfer function is

$$G(s)G_{\text{Lag}}(s)G_{\text{Lead}}(s) = \frac{2640.16(s+0.446)(s+1.727)}{s(s+1.32)(s+100)(s+0.0669)(s+11.51)}$$

b.

### Program:

```
%Input system *****
K=51.89;
numg=50.88*K;
deng=poly([0 -1.32 -100]);
G=tf(numg,deng);
Po=15;
z=(-log(Po/100))/(sqrt(pi^2+log(Po/100)^2));
%Determine required phase margin*****
Pmreq=atan(2*z/(sqrt(-2*z^2+sqrt(1+4*z^4))))*(180/pi)
phreq=Pmreq-(180)%required phase
w=0.1:0.01:10;
[M,P]=bode(G,w);
for i=1:length(P);%search for phase angle
if P(i)-phreq<=0;
ph=P(i)
w(i)
break
end
end
wpm=4.6*w(i)
```

## 11-4 Chapter 11: Design via Frequency Response

```

[M,P]=bode(G,wpm);%Find phase at wpm
Pmreqc=Pmreq-(180+P)+5;%Find contribution required from compensator+5
beta=(1-sin(Pmreqc*pi/180))/(1+sin(Pmreqc*pi/180))
%Design lag compensator*****
zclag=wpm/10;
pclag=zclag*beta;
Kclag=beta;
%Design lead compensator*****
zclead=wpm*sqrt(beta);
pclead=zclead/beta;
Kclead=1/beta;
%Create compensated forward path*****
numgclag=Kclag*[1 zclag];
dengclag=[1 pclag];
'Gclag(s)'
Gclag=tf(numgclag,dengclag);
Gclagzpk=zpk(Gclag)
numgclead=Kclead*[1 zclead];
dengclead=[1 pclead];
'Gclead(s)'
Gclead=tf(numgclead,dengclead);
Gcleadzpk=zpk(Gclead)
Gc=Gclag*Gclead;
'Ge(s)=G(s)*Gclag(s)*Gclead(s)'
Ge=Gc*G;
Gezpk=zpk(Ge)
%Test lag-lead compensator*****
T=feedback(Ge,1);
bode(Ge)
title('Lag-lead Compensated')
[Gm,Pm,wcp,wcg]=margin(Ge);
'Compensated System Results'
fprintf('\nResulting Phase Margin = %g',Pm)
fprintf(', Resulting Phase Margin Frequency = %g',wcp)
pause
step(T)
title('Lag-lead Compensated')

```

### Computer response:

```

Pmreq =

    53.1718

phreq =

   -126.8282

ph =

   -126.8660

ans =

    0.9700

wpm =

    4.4620
Pmreqc =

    44.2468

beta =

    0.1780

ans =

```

Gclag(s)

Zero/pole/gain:  
 0.17803 (s+0.4462)  
 -----  
 (s+0.07944)

ans =

Gclead(s)

Zero/pole/gain:  
 5.617 (s+1.883)  
 -----  
 (s+10.58)

ans =

Ge(s)=G(s)\*Gclag(s)\*Gclead(s)

Zero/pole/gain:  
 2640.1632 (s+1.883) (s+0.4462)  
 -----  
 s (s+100) (s+10.58) (s+1.32) (s+0.07944)

ans =

Compensated System Results

Resulting Phase Margin = 57.6157, Resulting Phase Margin Frequency = 2.68618»

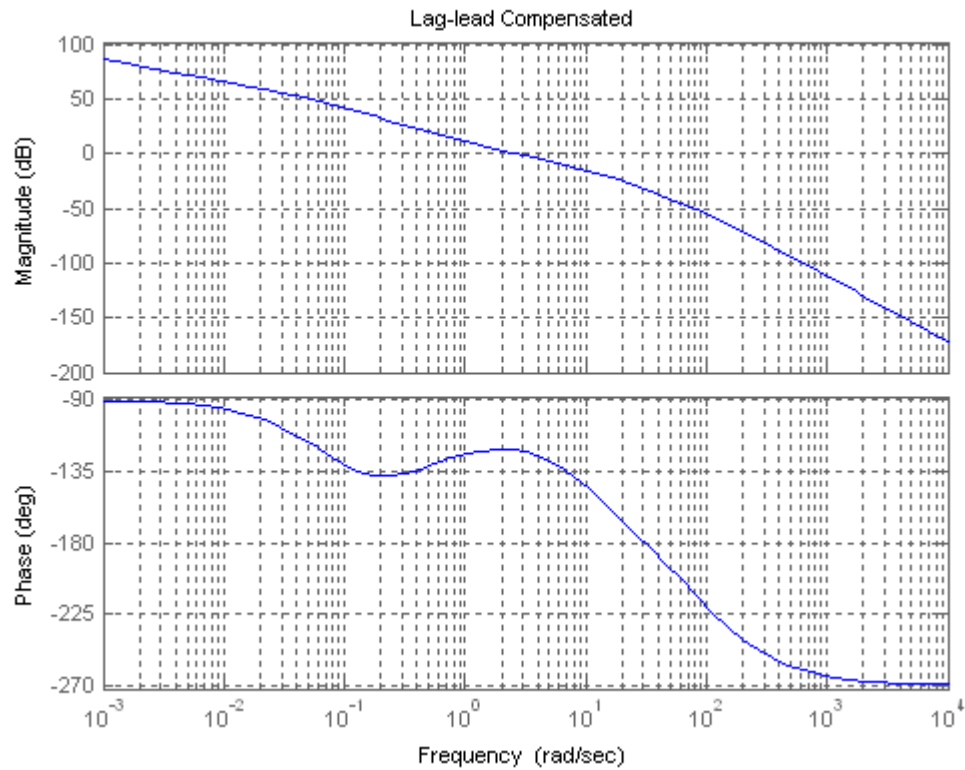

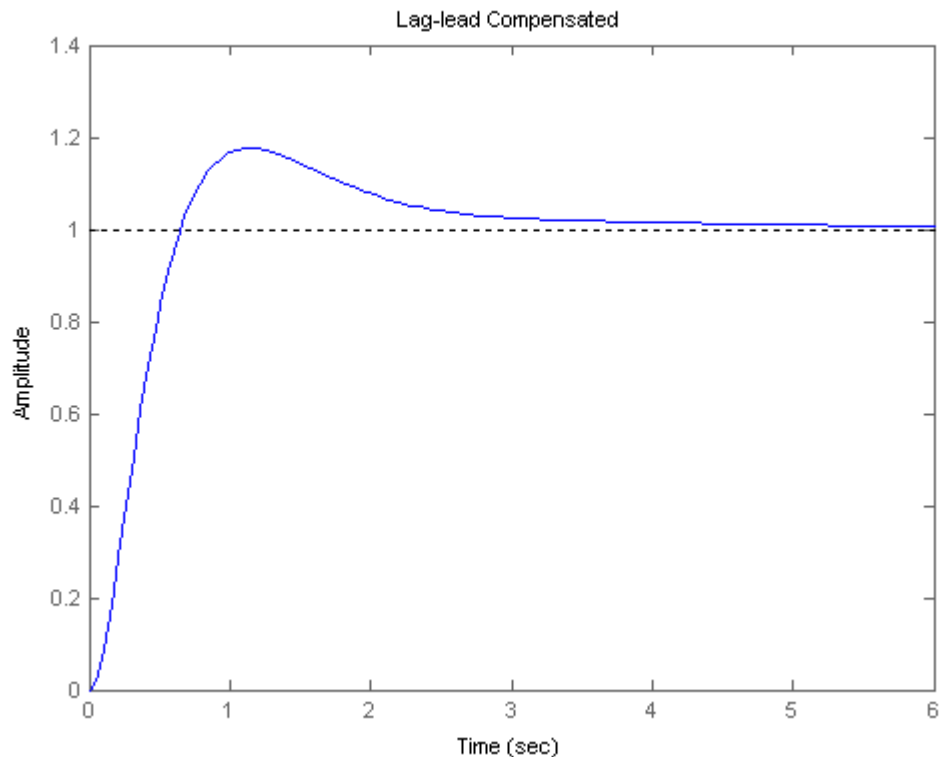

## Answers to Review Questions

1. Steady-state error requirements can be designed simultaneously with transient response requirements.
2. Via the phase margin
3. The lag compensator is a low pass filter. Thus, while the low frequency gain is increased, the high-frequency gain at  $180^\circ$  is decreased to make the system stable.
4. The lag network affects the phase angle at low frequencies, but not at high frequencies. For the compensated system, the phase plot is about the same as that of the uncompensated system around and above the phase margin frequency yielding the same transient response.
5. To compensate for the slight negative angle that the lag compensator has near the phase margin frequency
6. Compensated system has higher low-frequency gain than the uncompensated system designed to yield the same transient response; compensated and uncompensated system have the same phase margin frequency; the compensated system has lower gain around the phase margin frequency; the compensated and uncompensated system's have approximately the same phase values around the phase margin frequency.
7. The lead network is a high pass filter. It raises the gain at high frequencies. The phase margin frequency is increased.

8. Not only is the magnitude curve increased at higher frequencies, but so is the phase curve. Thus the  $180^\circ$  point moves up in frequency with the increase in gain.
9. To correct for the negative phase angle of the uncompensated system
10. When designing the lag portion of a lag-lead compensator, we do not worry about the transient design. The transient response will be considered when designing the lead portion of a lag-lead compensator.

## SOLUTIONS TO PROBLEMS

1.
  - a. Plot Bode plots for  $K = 1$ ; angle is  $180^\circ$  at  $\omega = 15.8$  rad/s where the magnitude is  $-76.5$  dB. Therefore a 66.5 dB ( or  $K = 2113$ ) increase will yield a 10 dB gain margin.

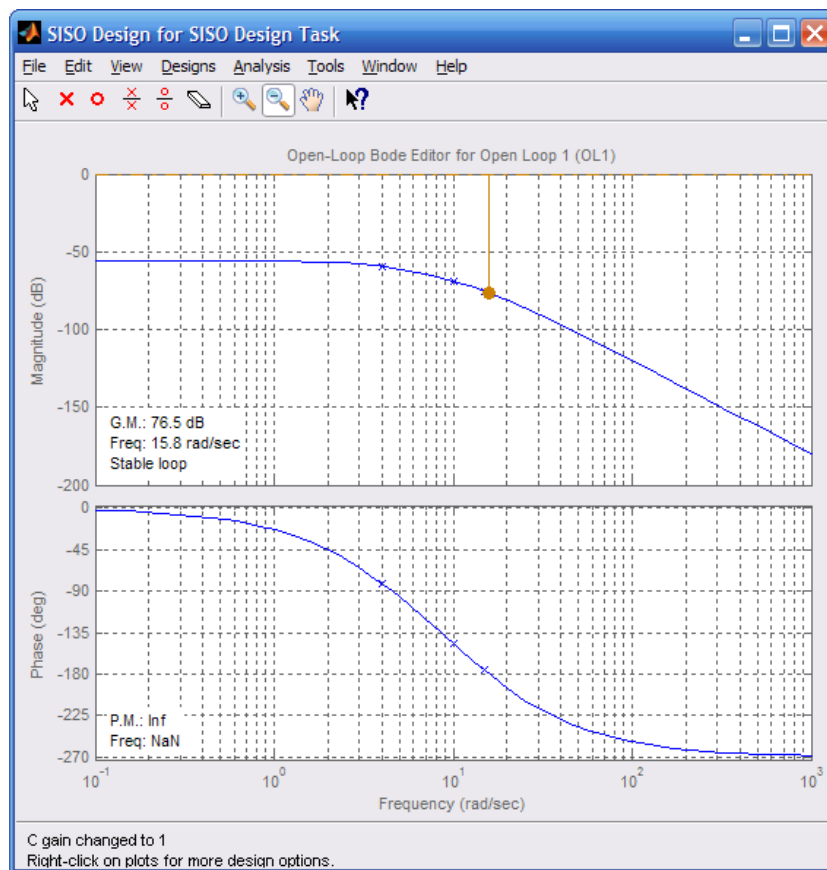

- b. Plot Bode plots for  $K = 1$ ; angle is  $180^\circ$  at  $\omega = 6.32$  rad/s where the magnitude is  $-55$  dB. Therefore a 45 dB ( or  $K = 177.8$ ) increase will yield a 10 dB gain margin.

11-8 Chapter 11: Design via Frequency Response

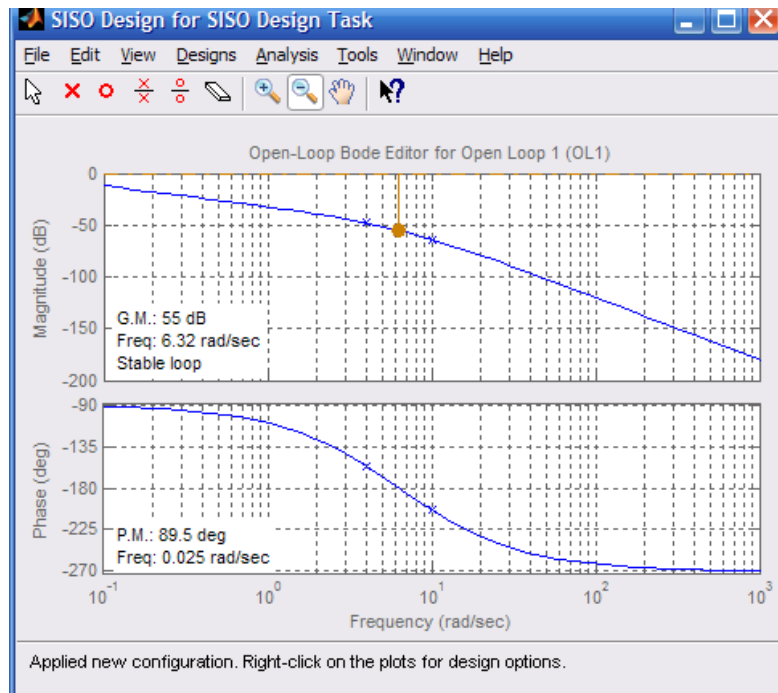

c. Plot Bode plots for  $K = 1$ ; angle is  $180^\circ$  at  $\omega = 9.45$  rad/s where the magnitude is  $-63.8$  dB. Therefore a 53.8 dB ( or  $K = 489.8$ ) increase will yield a 10 dB gain margin.

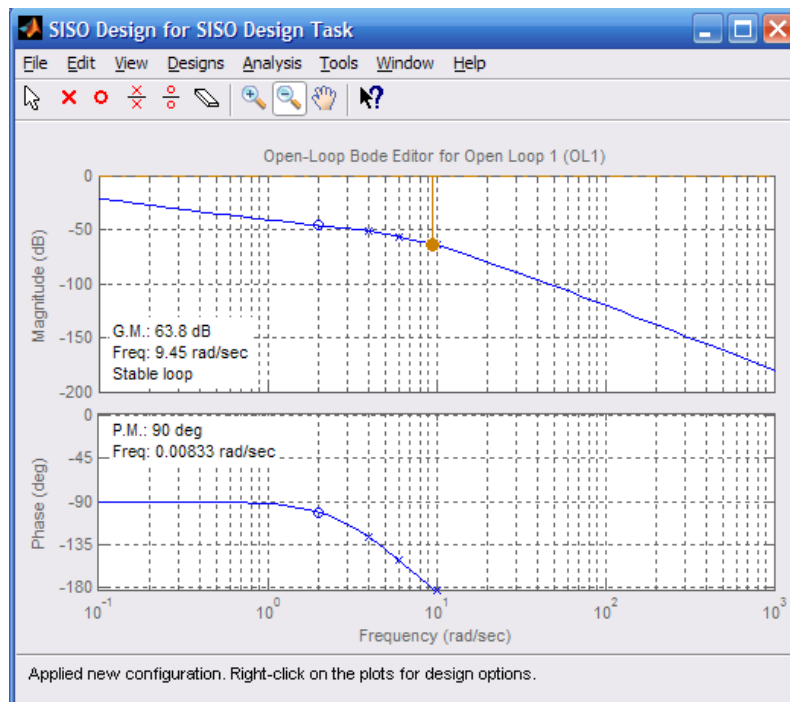

2.

**a.** For a  $40^\circ$  phase margin, the phase must be  $-140^\circ$  when the magnitude plot is zero dB. The phase is  $-140^\circ$  at  $\omega = 9.12$  rad/s. At this frequency, the magnitude curve is  $-67.48$  dB. Thus a  $67.48$  dB increase ( $K = 2365$ ) will yield a  $40^\circ$  phase margin.

**b.** For a  $40^\circ$  phase margin, the phase must be  $-140^\circ$  when the magnitude plot is zero dB. The phase is  $-140^\circ$  at  $\omega = 2.76$  rad/s. At this frequency, the magnitude curve is  $-42.86$  dB. Thus a  $42.86$  dB increase ( $K = 139$ ) will yield a  $40^\circ$  phase margin.

**c.** For a  $40^\circ$  phase margin, the phase must be  $-140^\circ$  when the magnitude plot is zero dB. The phase is  $-140^\circ$  at  $\omega = 5.04$  rad/s. At this frequency, the magnitude curve is  $-54.4$  dB. Thus a  $54.4$  dB increase ( $K = 525$ ) will yield a  $40^\circ$  phase margin.

3.

20% overshoot  $\Rightarrow \zeta = 0.456 \Rightarrow \phi_M = 48.15^\circ$ .

**a.** Looking at the phase diagram, where  $\phi_M = 48.15^\circ$  (i.e.  $\phi = -131.85^\circ$ ), the phase margin frequency =  $4.11$  rad/s. At this frequency, the magnitude curve is  $-55.2$  dB. Thus the magnitude curve has to be raised by  $55.2$  dB ( $K = 575$ ).

**b.** Looking at the phase diagram, where  $\phi_M = 48.15^\circ$  (i.e.  $\phi = -131.85^\circ$ ), the phase margin frequency =  $7.14$  rad/s. At this frequency, the magnitude curve is  $-65.6$  dB. Thus the magnitude curve has to be raised by  $65.6$  dB ( $K = 1905$ ).

**c.** Looking at the phase diagram, where  $\phi_M = 48.15^\circ$  (i.e.  $\phi = -131.85^\circ$ ), the phase margin frequency =  $8.2$  rad/s. At this frequency, the magnitude curve is  $-67.3$  dB. Thus the magnitude curve has to be raised by  $67.3$  dB ( $K = 2317$ ).

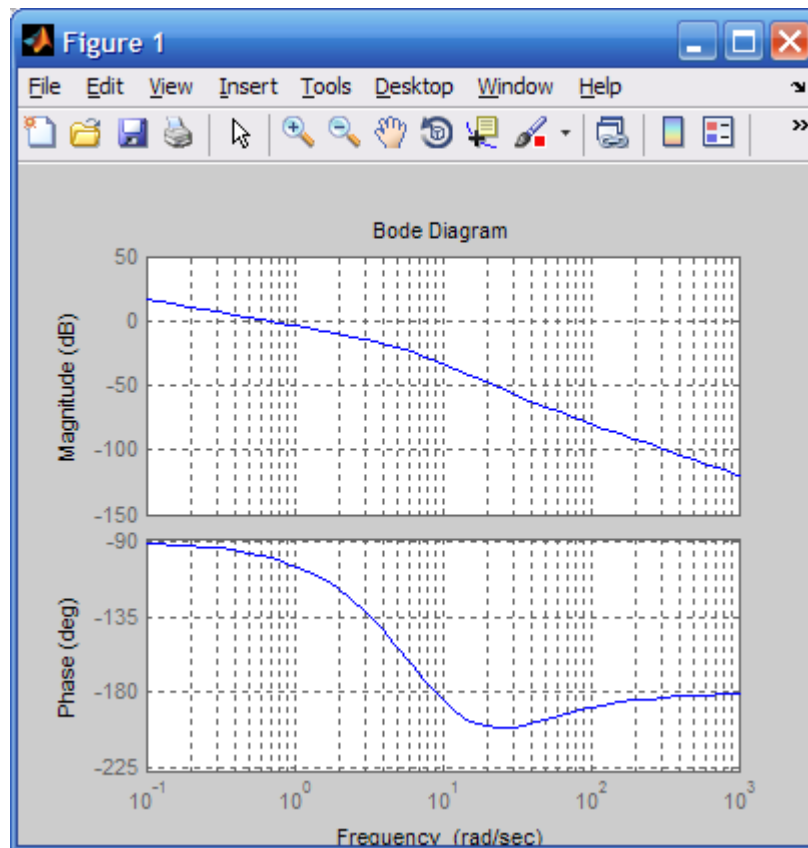

4.

a. Bode plots for  $K = 1$ :

Using Eqs. (4.39) and (10.73) a percent overshoot = 15 is equivalent to a  $\zeta = 0.517$  and  $\phi_M = 53.17^\circ$ .

The phase-margin frequency = 2.61 rad/s where the phase is  $53.17^\circ - 180^\circ = -126.83^\circ$ . The magnitude = -13 dB, or 0.02239. Hence  $K = 1/0.02239 = 4.466$ .

b.

**Program:**

```
G=zpk([-20 -25],[0 -6 -9 -14],1)
```

```
K=4.466
```

```
T=feedback(K*G,1);
```

```
step(T)
```

**Computer response:**

```
Zero/pole/gain:
      (s+20) (s+25)
```

```
-----
s (s+6) (s+9) (s+14)
```

```
K =
```

```
4.466
```

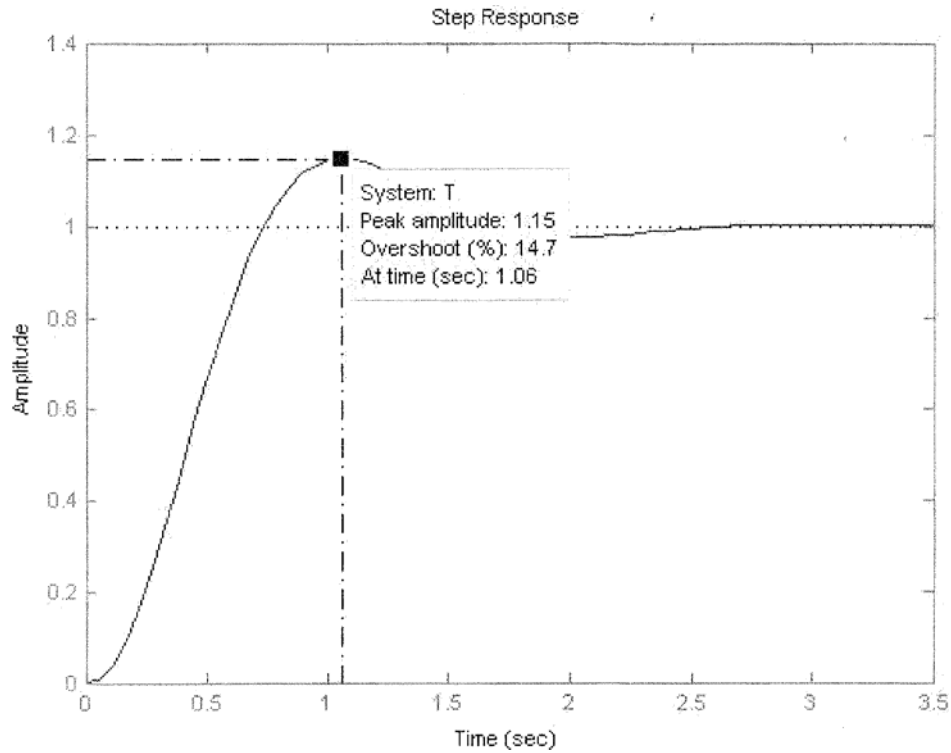

5.

For  $K_v = 50$ ,  $K = 350$ . Plot the Bode plots for this gain.

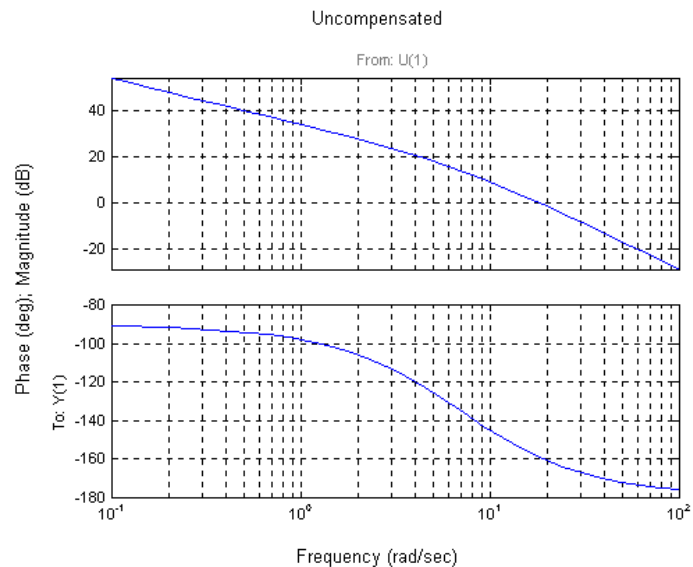

Also, since  $\%OS = 15\%$ ,  $\zeta = 0.517$ . Using Eq. (10.73),  $\phi_M = 53.17^\circ$ . Increasing  $\phi_M$  by  $10^\circ$  we will design for a phase margin of  $63.17^\circ$ . The phase margin frequency is where the phase angle is  $63.17 - 180^\circ = -116.83^\circ$ , or  $\omega_{\phi_M} = 3.54$  rad/s. At this frequency, the magnitude is 22 dB. Start the magnitude of the compensator at -22 dB and draw it to 1 decade below  $\omega_{\phi_M}$ .

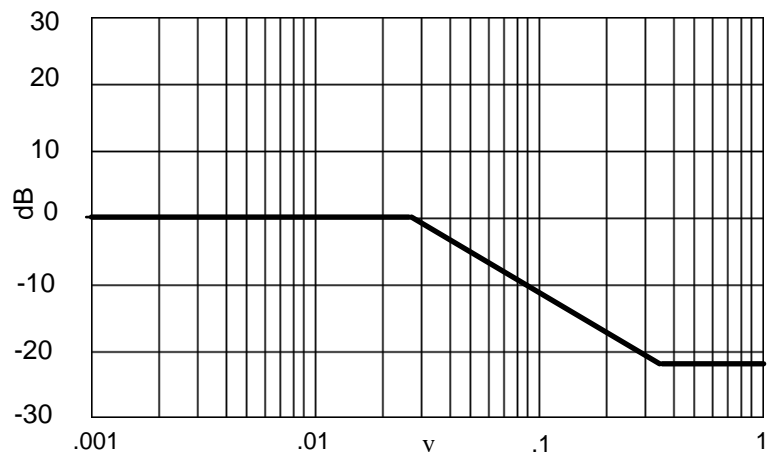

Then begin +20 dB/dec until zero dB is reached. Read the break frequencies as 0.028 rad/s and 0.354 rad/s from the Bode plot and form a lag transfer function that has unity dc gain:

$$G_c(s) = 0.0791 \frac{s + 0.354}{s + 0.028}$$

The compensated forward path is

$$G(s) = \frac{350 * 0.0791(s + 0.354)}{s(s + 7)(s + 0.028)} = \frac{27.69(s + 0.354)}{s(s + 7)(s + 0.028)}$$

6.

a. For  $K_v = 1000$ ,  $K = 1473$ . Plotting the Bode for this value of  $K$ :

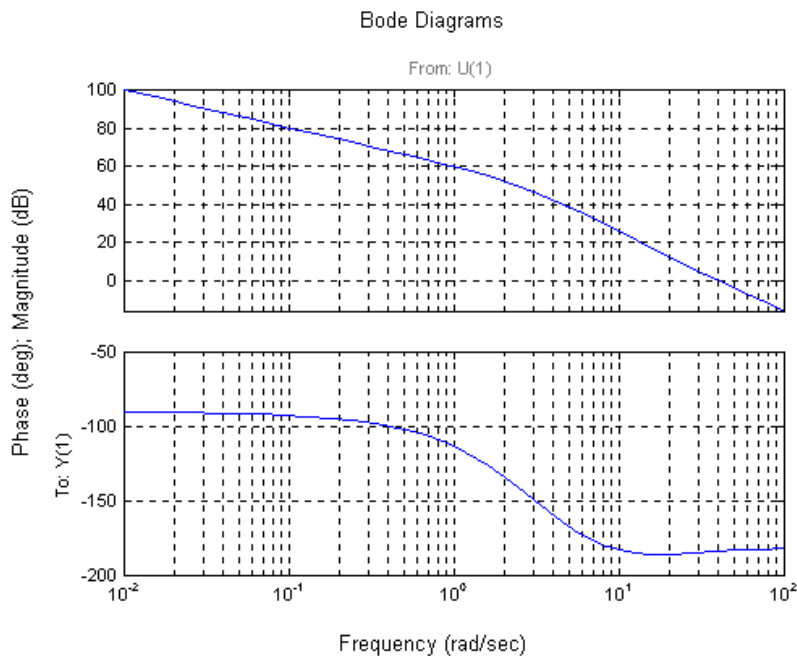

Using Eqs. (4.39) and (10.73) a percent overshoot = 15 is equivalent to a  $\zeta = 0.517$  and  $\phi_M = 53.17^\circ$ .

Using an extra  $10^0$ , the phase margin is  $63.17^\circ$ . The phase-margin frequency = 1.21 rad/s. At this

frequency, the magnitude = 57.55 dB = 754.2. Hence the lag compensator  $K = 1/754.2 = 0.001326$ .

Following Steps 3 and 4 of the lag compensator design procedure in Section 11.3,

$$G_{\text{lag}}(s) = 0.001326 \frac{s + 0.121}{s + 0.0001604}$$

**b.**

**Program:**

```
%Input system
numg=1473*poly([-10 -11]);
deng=poly([0 -3 -6 -9]);
G=tf(numg,deng);
numc=0.001326*[1 0.121];
denc=[1 0.0001604];
Gc=tf(numc,denc);
Ge=G*Gc;
T=feedback(Ge,1);
step(T)
```

**Computer response:**

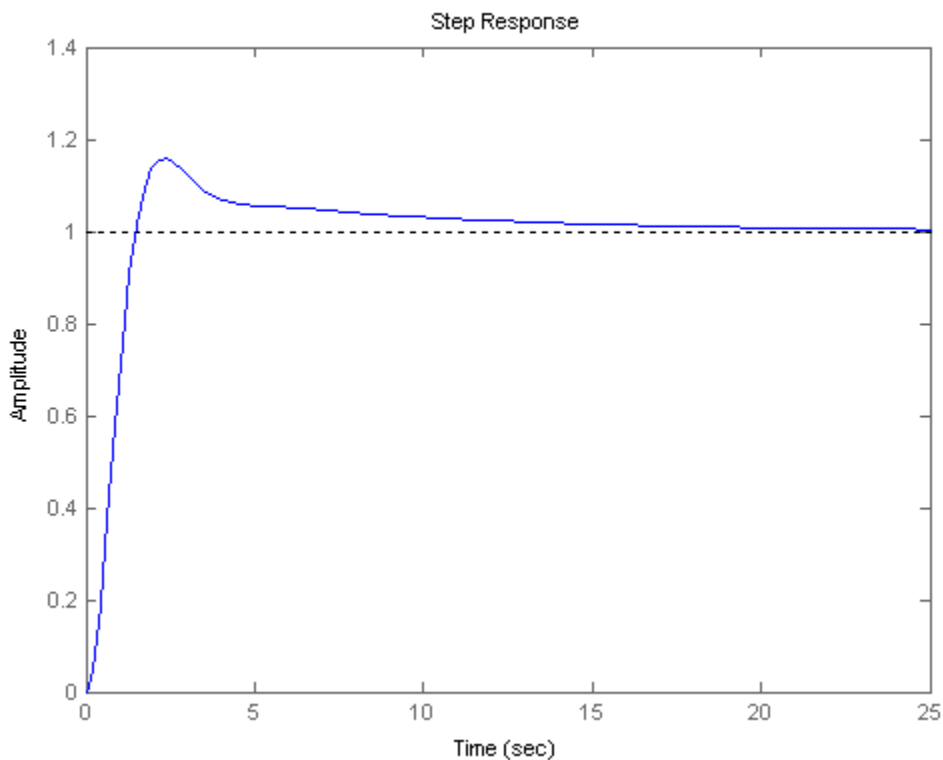

7.

**Uncompensated system:**

Searching along the  $121.1^\circ$  line (15% overshoot), find the dominant pole at  $-2.15 \pm j3.56$  with  $K =$

97.7. Therefore, the uncompensated static error constant is  $K_{V0} = \frac{97.7}{70} = 1.396$ . On the frequency

response curves, plotted for  $K = 97.7$ , unity gain occurs at  $\omega = 1.64$  rad/s with a phase angle of  $-71^\circ$ . Therefore the uncompensated phase margin is  $180^\circ - 71^\circ = 109^\circ$ .

**Compensated system:**

The old steady-state error,  $e_{step}(\infty) = \frac{1}{1 + K_{po}} = \frac{1}{1 + \frac{97.7}{70}} = 0.4174$ . For a 5 times improvement

in steady-state error,  $e_{step}(\infty) = \frac{1}{1 + K_{pn}} = 0.0835$ , yielding,  $K_{pn} = 10.98 = \frac{K}{70}$ . Thus

$K = 768.6$ . Plotting the Bode plots at this gain,

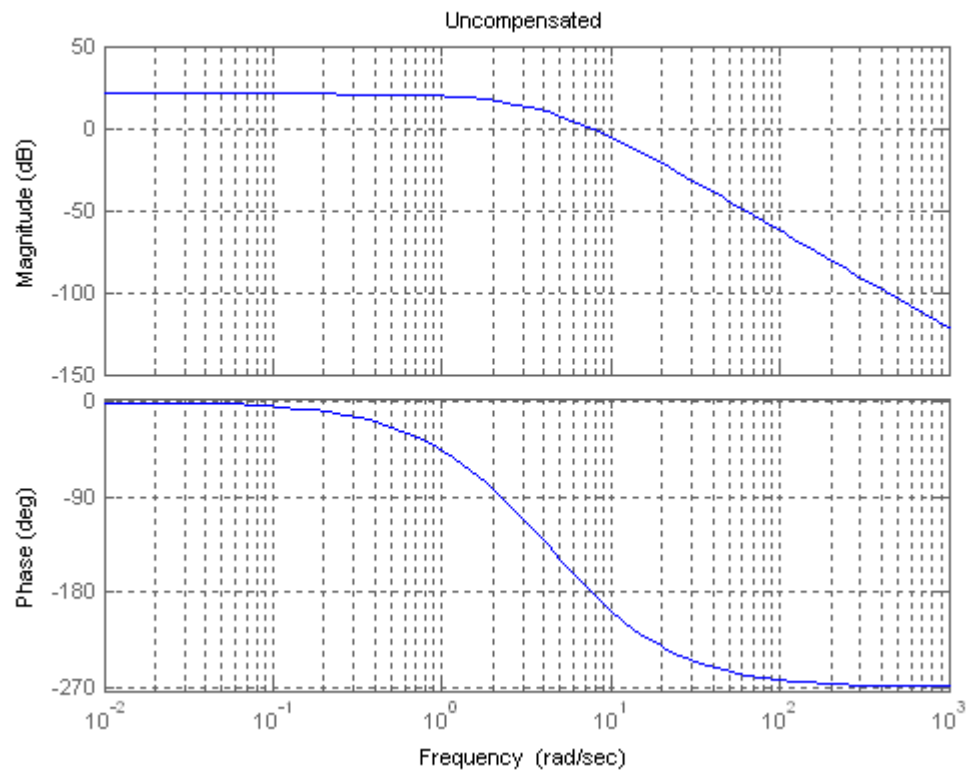

Adding  $5^\circ$ , the desired phase margin for 15% overshoot is  $58.17^\circ$ , or a phase angle of  $-121.83^\circ$ . This phase angle occurs at  $\omega = 3.505$  rad/s. At this frequency the magnitude plot is  $+12$  dB. Start the magnitude of the compensator at  $-12$  dB and draw it to 1 decade below  $\omega_{\phi M}$ .

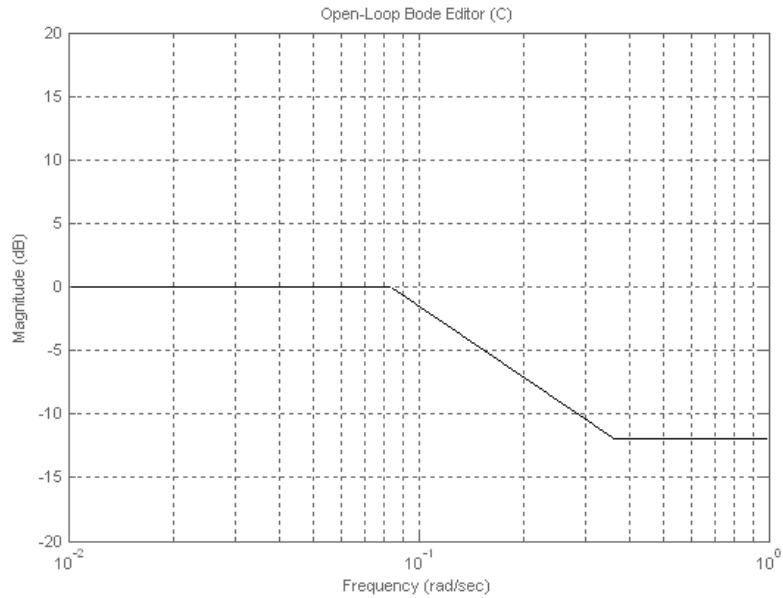

Then, begin +20 dB/dec until zero dB is reached. Read the break frequencies as 0.08797 rad/s and 0.3505 rad/s from the Bode plot and form a lag transfer function that has unity dc gain,

$$G_c(s) = 0.251 \frac{s + 0.3505}{s + 0.08797}$$

The compensated forward path is

$$G(s) = 0.251 * 768.6 \frac{(s + 0.3505)}{(s + 2)(s + 5)(s + 7)(s + 0.08797)} = \frac{192.91(s + 0.3505)}{(s + 2)(s + 5)(s + 7)(s + 0.08797)}$$

8.

For  $K_p = 100 = \frac{K(4)}{(2)(6)(8)}$ ,  $K = 2400$ . Plotting the Bode plot for this gain,

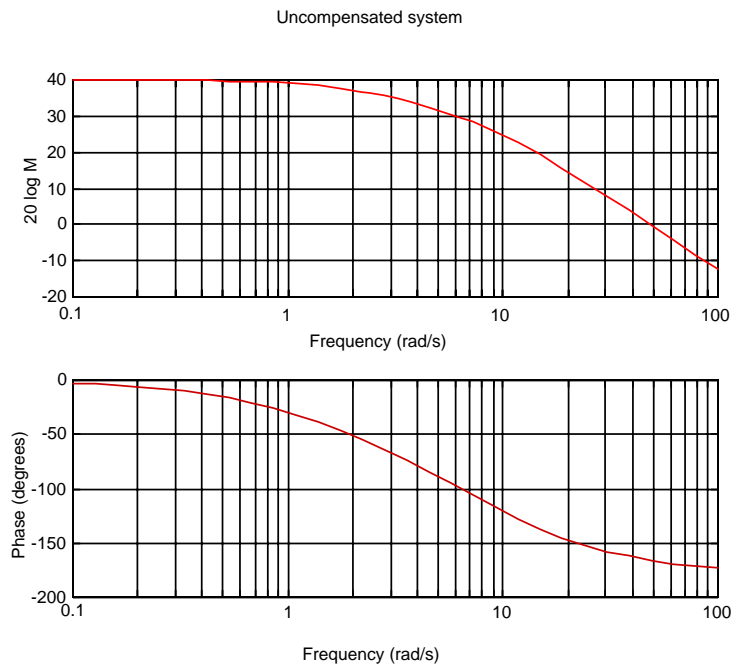

We will design the system for a phase margin  $10^0$  larger than the specification. Thus  $\phi_m = 55^0$ . The phase margin frequency is where the phase angle is  $-180^0 + 55^0 = -125^0$ . From the Bode plot this frequency is  $\omega_{\phi_m} = 11$  rad/s. At this frequency the magnitude is 23.37 dB. Start the magnitude of the lag compensator at  $-23.37$  dB and draw it to 1 decade below  $\omega_{\phi_m} = 11$ , or 1.1 rad/s. Then begin a  $+20$  dB/dec climb until 0 dB is reached. Read the break frequencies as 0.0746 rad/s and 1.1 rad/s from the Bode plot as shown below.

## Lag compensator

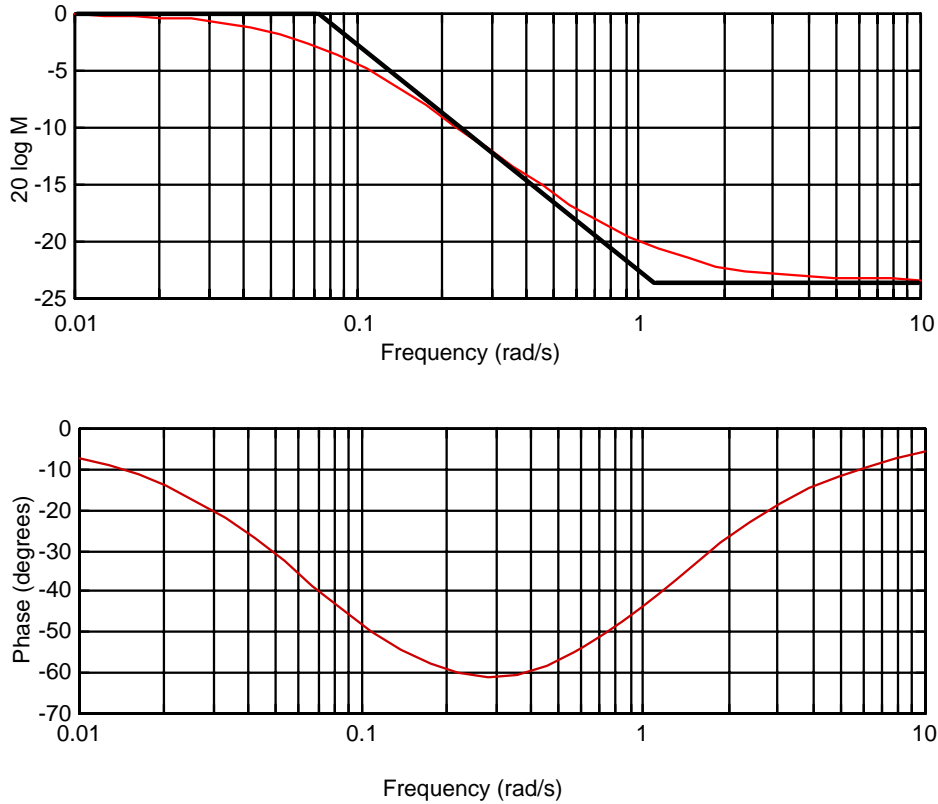

Ensuring unity dc gain, the transfer function of the lag is  $G_{lag}(s) = 0.06782 \frac{(s+1.1)}{(s+0.0746)}$ . The compensated forward-path transfer function is thus the product of the plant and the compensator, or

$$G_e(s) = \frac{162.8(s+4)(s+1.1)}{(s+2)(s+6)(s+8)(s+0.0746)}$$

9.

From Example 11.1,  $K = 58251$  yields 9.48% overshoot or a phase margin of  $59.19^\circ$ . Also,

$$G(s) = \frac{58251}{s(s+36)(s+100)}$$

Allowing for a  $10^\circ$  contribution from the PI controller, we want a phase margin of  $69.19^\circ$ , or a phase angle of  $-180^\circ + 69.19^\circ = -110.81^\circ$ . This phase angle occurs at  $\omega = 9.8$  rad/s where the magnitude is 4 dB. Thus, the PI controller should contribute -4 dB at  $\omega = 9.8$  rad/s. Selecting a break frequency a decade below the phase margin frequency,

$$G_c(s) = \frac{s+0.98}{s}$$

This function has a high-frequency gain of zero dB. Since we want a high-frequency gain of -4 dB (a gain of 0.631),



$$G_c(s) = 0.631 \frac{s+0.98}{s}$$

The compensated forward path is

$$G(s) = \frac{58251 \cdot 0.631(s+0.98)}{s(s+36)(s+100)} = \frac{36756.38(s+0.98)}{s(s+36)(s+100)}$$

10.

Bode plots for  $K = 1$ :

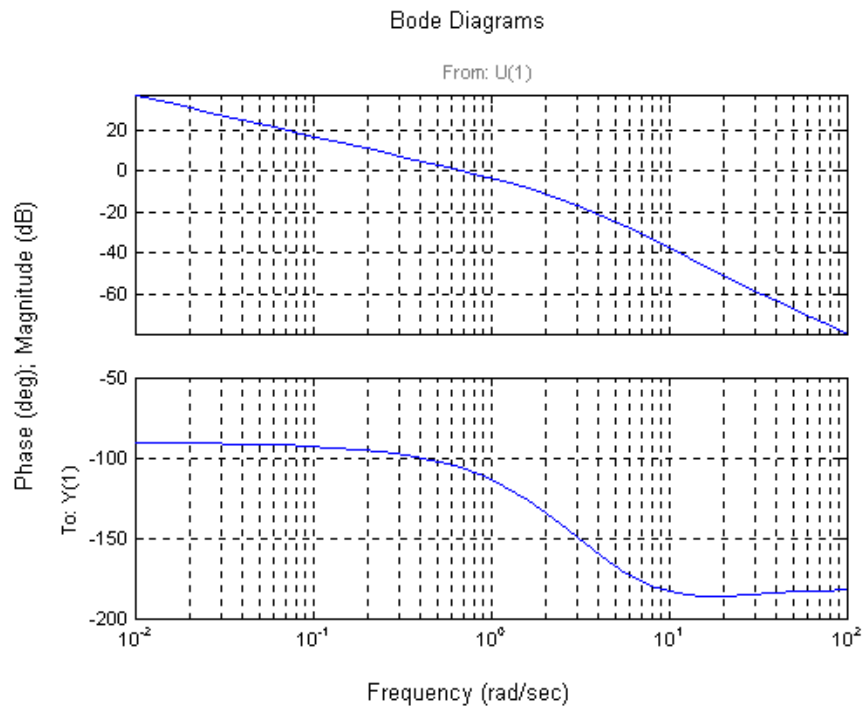

Using Eqs. (4.39) and (10.73) a percent overshoot = 15 is equivalent to a  $\zeta = 0.517$  and  $\phi_M = 53.17^\circ$ . The phase-margin frequency = 1.66 rad/s. The magnitude = -9.174 dB = 0.3478. Hence  $K = 1/0.3478 = 2.876$ .

**b.**

Bode plots for  $K = 2.876$ .

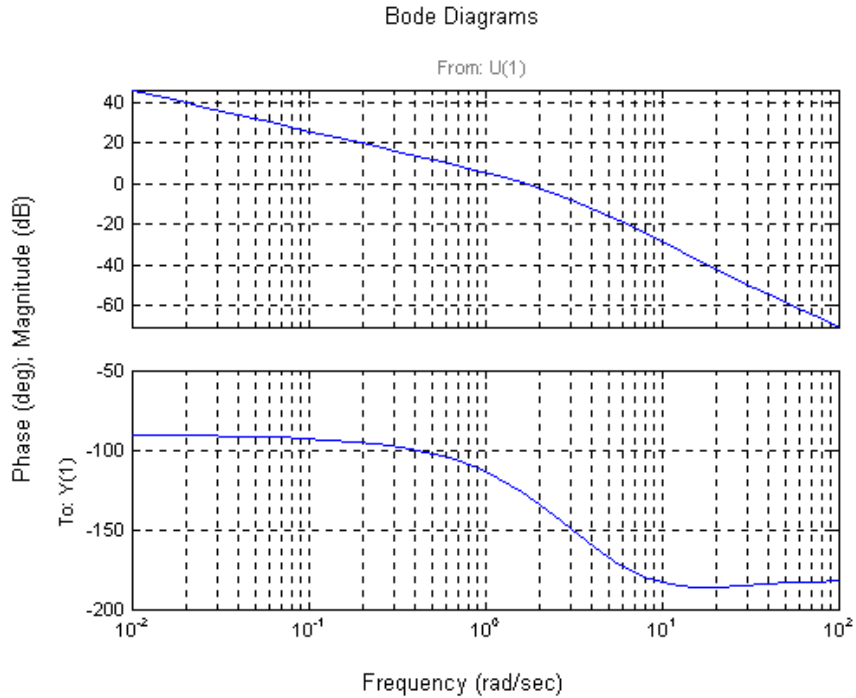

Adding  $10^0$  to the phase margin yields 63.17. Thus, the required phase is  $-180^0 + 63.17^0 = -116.83^0$ , which occurs at a frequency of 1.21 rad/s. The magnitude = 3.366 dB = 1.473. Hence, the lag compensator  $K = 1/1.473 = 0.6787$ . Selecting the break a decade below the phase-margin frequency,

$$G_c(s) = 0.6787 \frac{s+0.121}{s}$$

**c.**

**Program:**

```
%Input system
numg=2.876*poly([-10 -11]);
deng=poly([0 -3 -6 -9]);
G=tf(numg,deng);
numc=0.6787*[1 0.121];
denc=[1 0];
Gc=tf(numc,denc);
Ge=G*Gc;
T=feedback(Ge,1);
step(T)
```

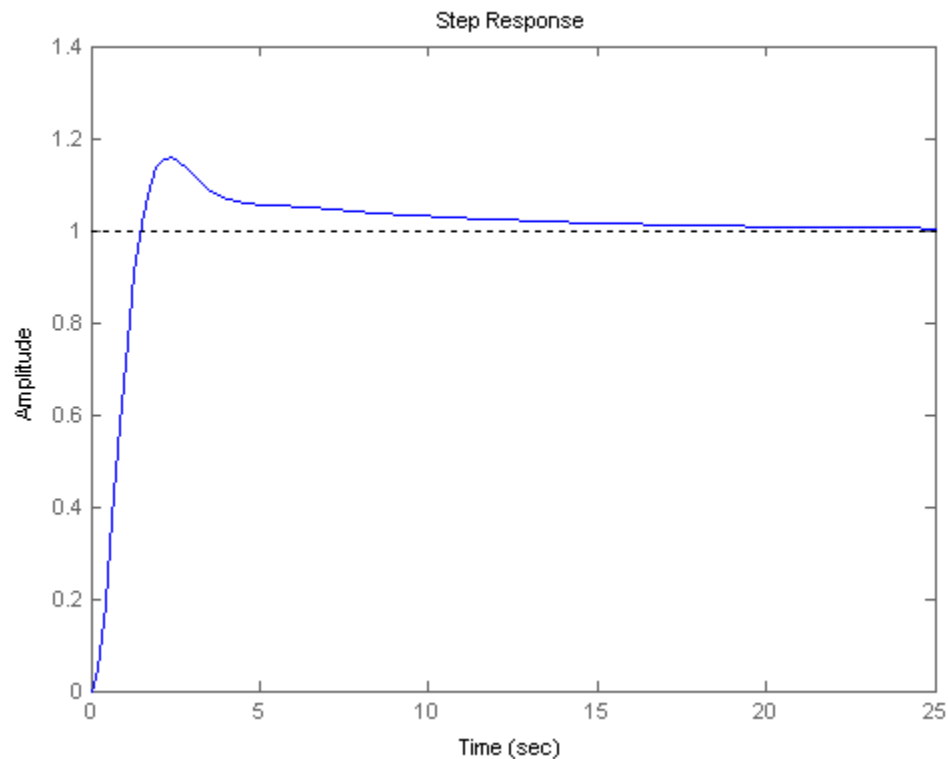
**Computer response:**

11.

**Program:**

```
%PI Compensator Design via Frequency Response
%Input system
G=zpk([],[-5 -10],1);
G=tf(G);
%Percent Overshoot to Damping Ratio to Phase Margin
Po=input('Type %OS ');
z=(-log(Po/100))/(sqrt(pi^2+log(Po/100)^2));
Pm=atan(2*z/(sqrt(-2*z^2+sqrt(1+4*z^4))))*(180/pi)+10;
fprintf('\nPercent Overshoot = %g',Po)
fprintf(', Damping Ratio = %g',z)
fprintf(', Phase Margin = %g',Pm)
%Get Bode data
bode(G)
title('Uncompensated')
pause
%Find frequency at desired phase margin and the gain at this frequency
w=logspace(-1,2,10000);
%w=.1:0.1:100;
[M,P,w]=bode(G,w);
Ph=-180+Pm
for i=1:1:length(P);
if P(i)-Ph<=0
Mag=M(i)
wf=w(i);
fprintf(', Frequency = %g',wf)
fprintf(', Phase = %g',P(i))
fprintf(', Magnitude = %g',Mag)
fprintf(', Magnitude (dB) = %g',20*log10(Mag))
break
end
end
end
```

```

%Design PI compensator
%Break frequency is a decade below phase margin frequency
wh=wf/10;
%Magnitude is reciprocal of magnitude of G at the phase margin frequency
%so net magnitude is 0 dB at the phase margin frequency
Kc=1/Mag
'PI Compensator'
Gpi=tf(Kc*[1 wh],[1 0])
bode(Gpi)
title(['PI compensator'])
pause
'G(s)Gpi(s)'
Ge=series(G,Gpi);
Ge=zpk(Ge)
bode(Ge)
title('PI Compensated')
[Gm,Pm,Wcp,Wcg]=margin(Ge);
'Gain margin(dB); Phase margin(deg.); 0 dB freq. (r/s);'
'180 deg. freq. (r/s)'
margins=[20*log10(Gm),Pm,Wcg,Wcp]
pause
T=feedback(Ge,1);
step(T)
title('PI Compensated')

```

**Computer response:**

```
Type %OS 25
```

```
Percent Overshoot = 25, Damping Ratio = 0.403713, Phase Margin = 53.463
Ph =
```

```
-126.5370
```

```
Mag =
```

```
0.0037
```

```
, Frequency = 14.5518, Phase = -126.54, Magnitude = 0.00368082, Magnitude
(dB) = -48.6811
```

```
Kc =
```

```
271.6786
```

```
ans =
```

```
PI Compensator
```

```
Transfer function:
```

```
271.7 s + 395.3
```

```
-----
s
```

```
ans =
```

```
G(s)Gpi(s)
```

```
Zero/pole/gain:
```

```
271.6786 (s+1.455)
```

```
-----
s (s+10) (s+5)
```

# 11-22 Chapter 11: Design via Frequency Response

ans =

Gain margin(dB); Phase margin(deg.); 0 dB freq. (r/s);

ans =

180 deg. freq. (r/s)

margins =

Inf 47.6277 14.5975 Inf

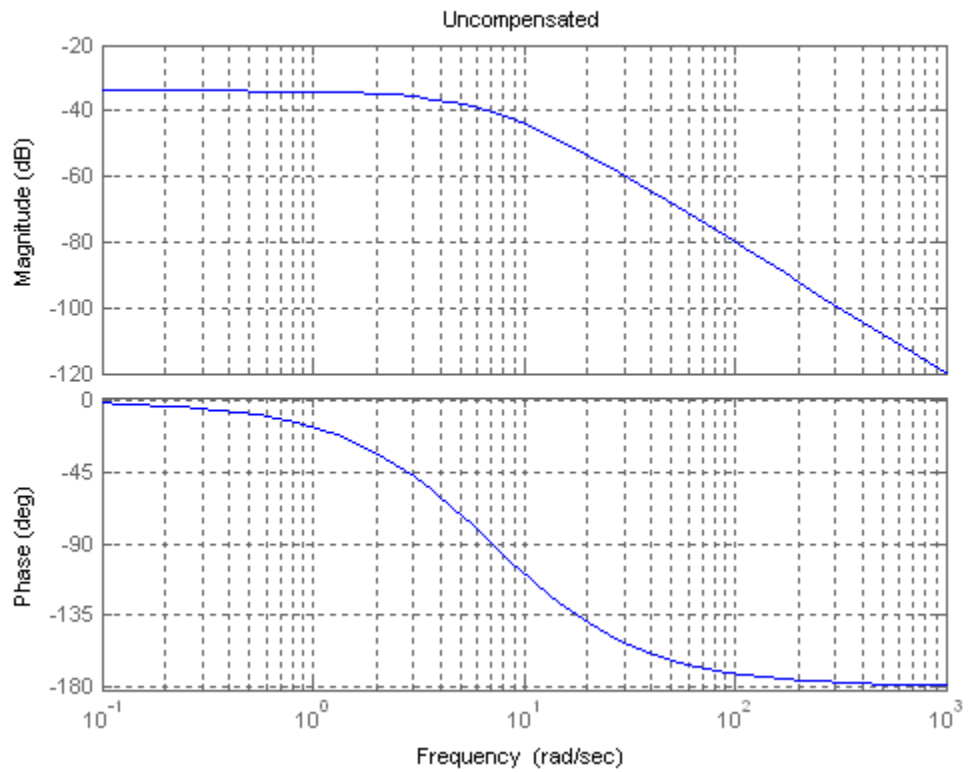

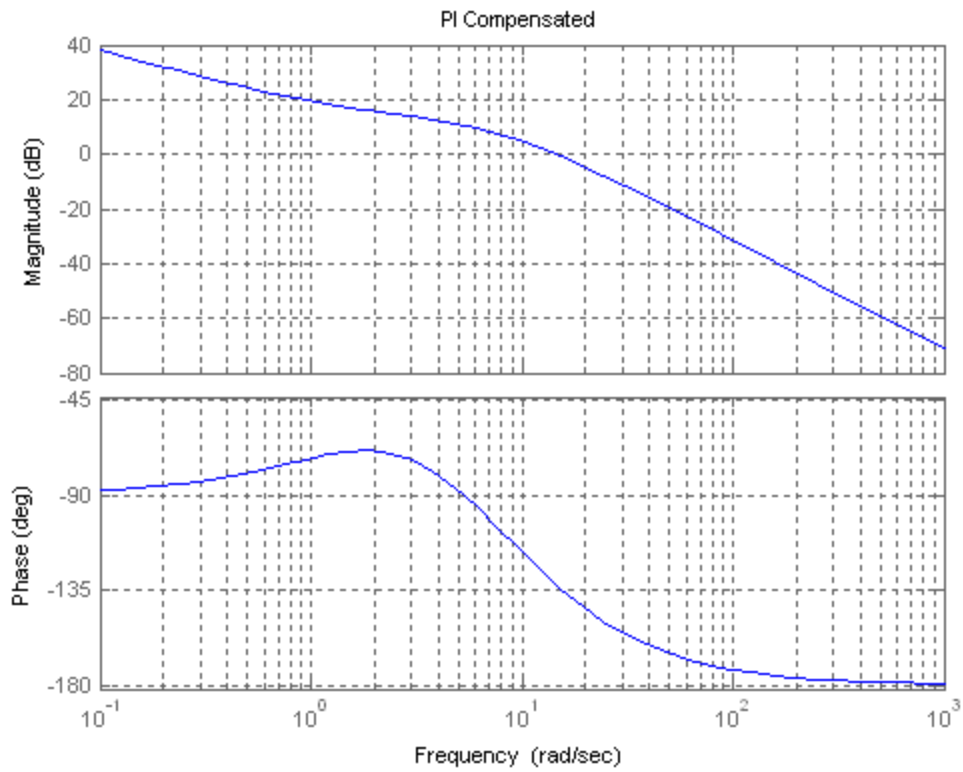
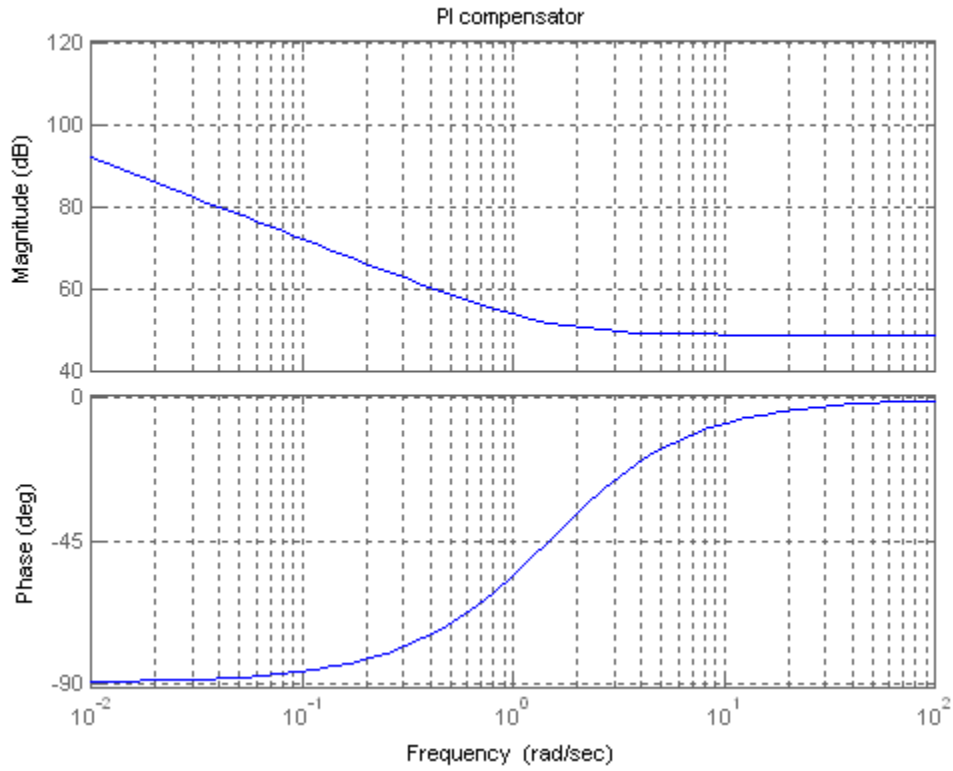

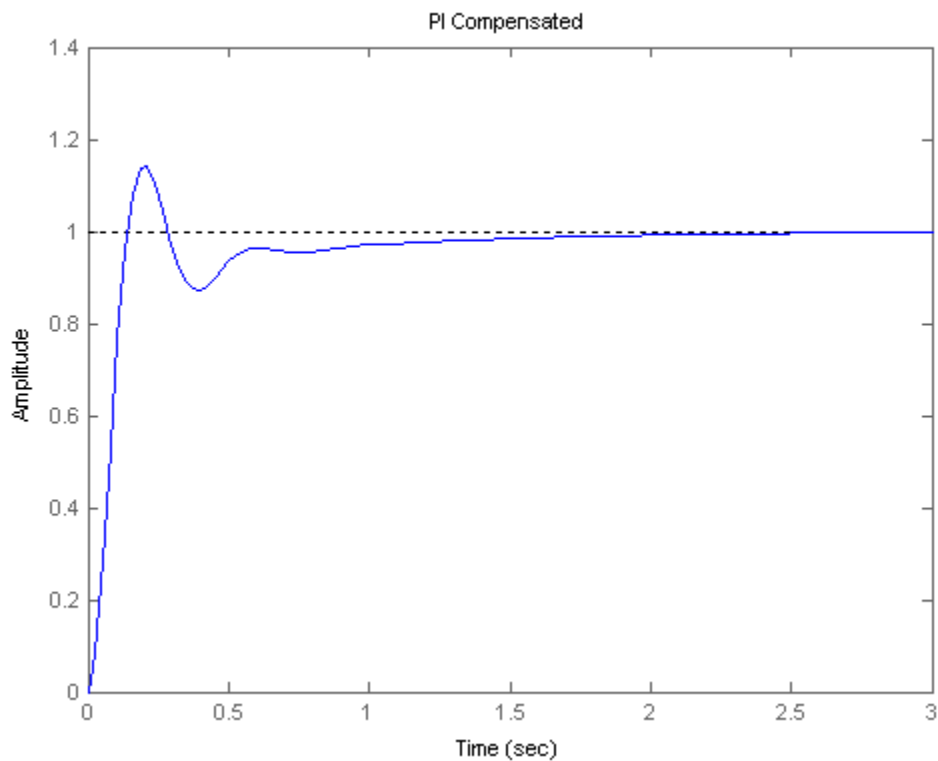

12.

For  $K_v = 4$ ,  $\frac{K}{900} = 4$ , or  $K = 3600$ . Plot the Bode diagrams.

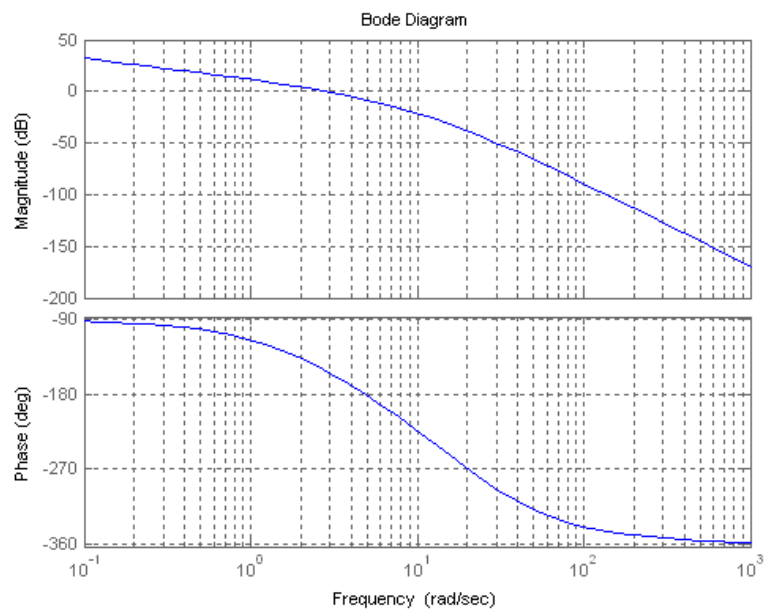

The magnitude curve crosses zero dB at  $\omega = 2.83$  rad/s. with a phase angle of  $152.1^\circ$ , which yields an

uncompensated phase margin of  $27.9^\circ$ . Thus, we need an additional  $12.1^\circ$  plus an additional amount to compensate for the fact that the phase margin frequency will increase. Assume a lead network with a phase contribution of  $22.1^\circ$ . Using Eqs. (11.11), and (11.12),

The value of beta is:	0.453
The $ G(j\omega_{max}) $ for the compensator is:	1.485
or in db:	3.44

The magnitude curve has a gain of  $-3.44$  dB at  $\omega = 3.625$  rad/s. Therefore, choose this frequency as the new phase margin frequency. Using Eqs. (11.9) and (11.6), the compensator transfer function has the following specifications:

T	0.41
zero	-2.44
pole	-5.38
gain	2.21

The compensated forward path is

$$G(s) = \frac{3600 * 2.21(s + 2.44)}{s(s + 3)(s + 15)(s + 20)(s + 5.38)} = \frac{7956(s + 2.44)}{s(s + 3)(s + 15)(s + 20)(s + 5.38)}$$

A Bode plot of  $G(s)$  shows a phase margin of  $37.8^\circ$ . Thus, a redesign is necessary to meet the exact requirement. This redesign can be done by adding a larger correction factor to the phase required from the lead compensator, See Control Solutions for the redesign.

13.

a. Gain-compensated time response:

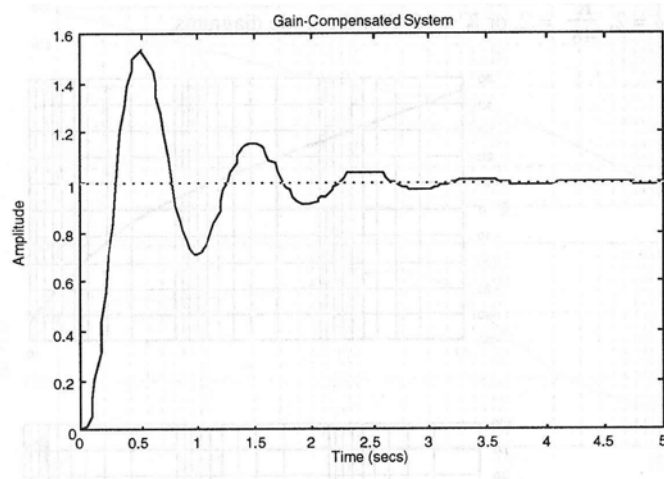



Bode plots for  $K = 1000$  ( $K_v = 10$ ):

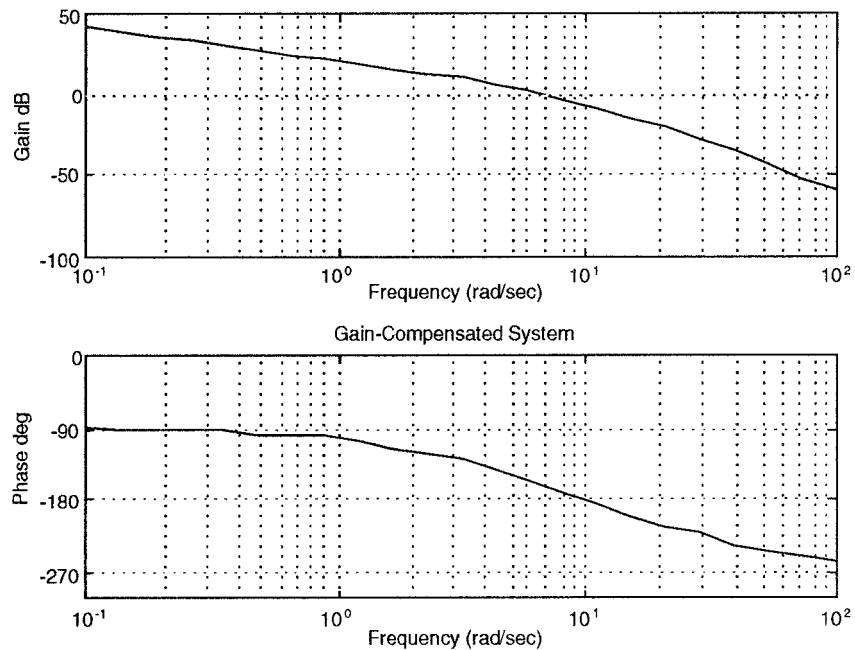

The specifications for the gain compensated system are:  $K = 1000$ , percent overshoot = 10,  $\zeta = 0.591155$ , peak time = 0.5 s, current phase margin =  $22.5362^\circ$ .

To meet the requirements: required phase margin (Eq. 10.73) =  $58.5931^\circ$ , required phase margin with correction factor of  $20^\circ = 78.5931$ , required bandwidth (Eq. 10.56) = 9.03591, required phase contribution from compensator =  $78.5931^\circ - 22.5362^\circ = 56.0569^\circ$ , compensator beta (Eq. 11.11) = 0.0931398, new phase margin frequency (Eq. 11.12) = 11.51.

Now design the compensator: Compensator gain  $K_c = 1/\beta = 10.7366$ , compensator zero (Eq. 11.12) = -3.51272, compensator pole =  $z_c/\beta = -37.7144$ .

**Lead-compensated Bode plots:**

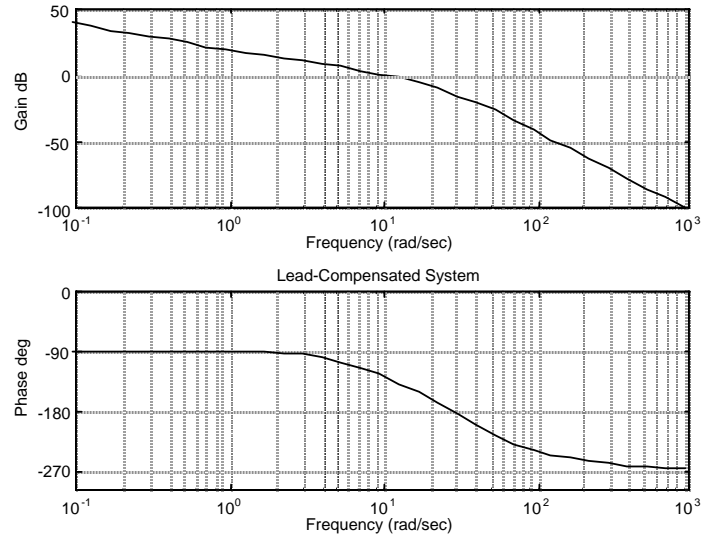

Lead-compensated phase margin = 50.2352.

**b.**

**Program:**

```
numg=1000;
deng=poly([0 -5 -20]);
G=tf(numg,deng);
numc=[1 3.51272];
denc=[1 37.7144];
Gc=tf(numc,denc);
Ge=G*10.7366*Gc;
T=feedback(Ge,1);
step(T)
```

**Computer response:**

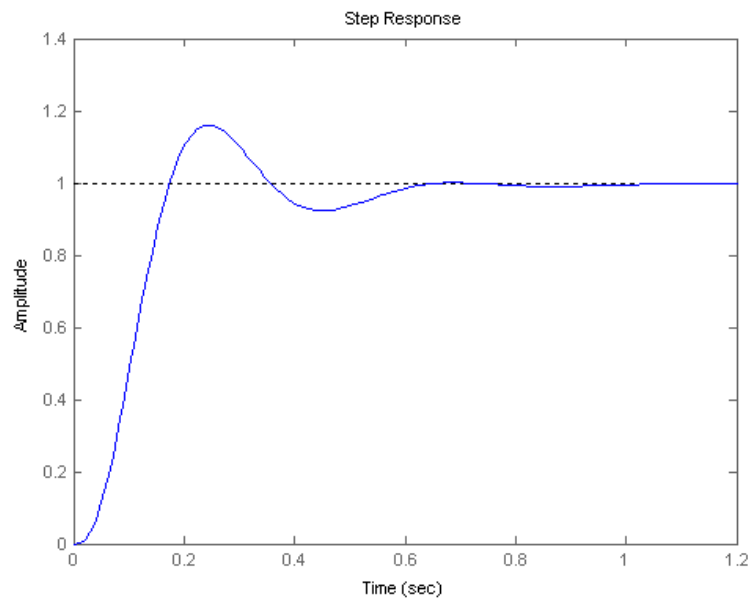

14.

**Uncompensated system:** Searching the  $\zeta = 0.456$  line (20% overshoot), find the dominant poles

$Q = -6.544 \pm j12.771$  with a gain of 178.21. Hence,  $T_s = \frac{4}{\zeta\omega_n} = 0.611$  second,

$K_p = \frac{178.21 * 5}{2 * 6 * 10} = 7.425$ . The Bode plot for the uncompensated system is:

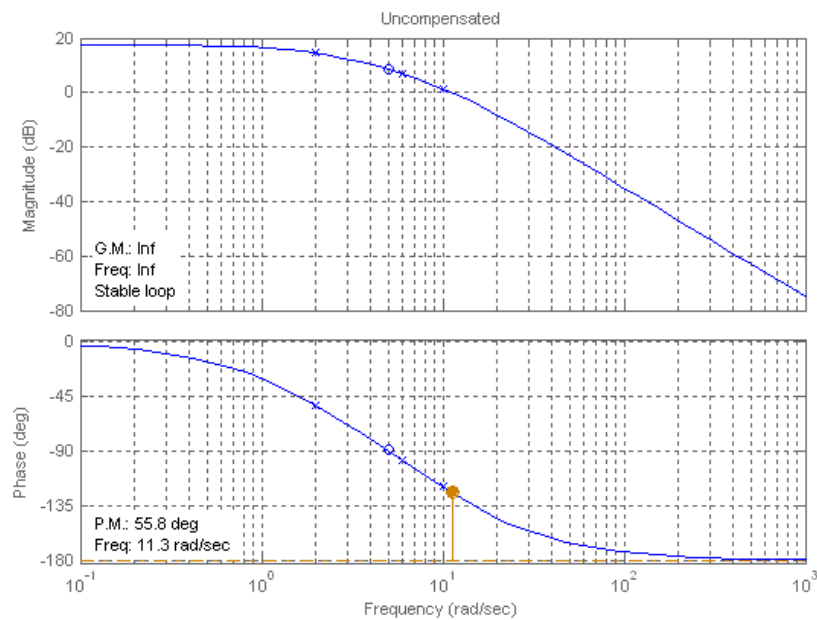

The uncompensated system has a phase margin of  $55.8^\circ$  and a phase margin frequency of 11.3 rad/s.

**Compensated system:** For a threefold improvement in  $K_p$ ,  $K_{pn} = 22.28$ . Therefore,  $K = 3 * 178.21 = 534.63$ . For a twofold reduction in settling time, the new dominant poles are  $Q_n = 2Q = -13.09 \pm j25.54$ . The gain adjusted system is

$$G_c(s) = \frac{534.63(s+5)}{(s+2)(s+6)(s+10)}$$

Plotting the Bode diagrams for the gain compensated system,

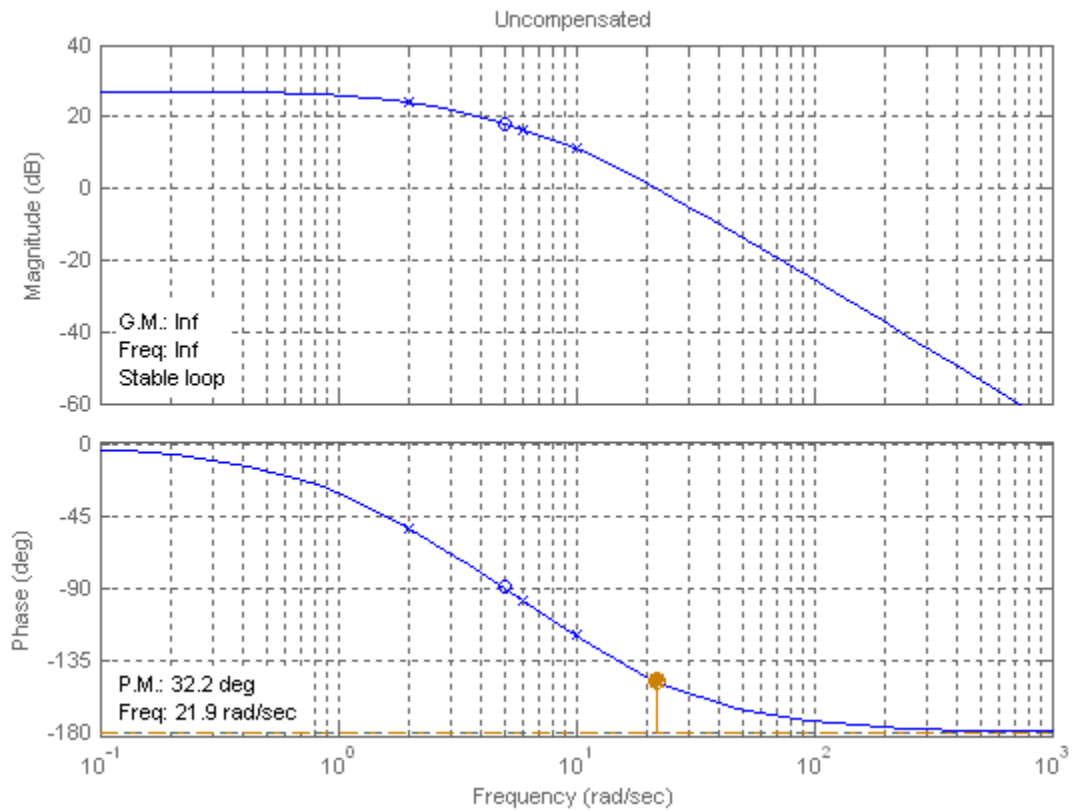

At unity gain the phase is  $-147.8^\circ$  at  $\omega = 21.9$  rad/s. Thus, the gain compensated phase margin is  $180^\circ - 147.8^\circ = 32.2^\circ$ . Using Eq. (10.73) with  $\zeta = 0.456$  (i.e. 20% overshoot), the required  $\Phi_M = 48.15^\circ$ . We add  $15.95^\circ$  plus a correction factor of  $5^\circ$  to the phase margin of the gain compensated system for a total additional phase of  $20.95^\circ$ . Using Eqs. (11.11), and (11.12),

The value of beta is:	0.473
The $ G(j\omega_{max}) $ for the compensator is:	1.45
or in db:	3.25

The magnitude curve has a gain of  $-3.25$  dB at  $\omega = 26.9$  rad/s. Therefore, choose this frequency as the new phase margin frequency. Using Eqs. (11.9) and (11.6), the compensator transfer function has the following specifications:

T	0.054
zero	-18.51
pole	-39.1
gain	2.11

The compensated forward path is

$$G(s) = \frac{534.63 * 2.11(s+5)(s+18.51)}{(s+2)(s+6)(s+10)(s+39.1)} = \frac{1128.1(s+5)(s+18.51)}{(s+2)(s+6)(s+10)(s+39.1)}$$

A simulation of the system shows percent overshoot = 23.2%, settling time = 0.263, phase margin = 48.4°, phase margin frequency = 26.7 r/s.

15.

If  $G(s) = \frac{144000}{s(s+36)(s+100)}$ ,  $K_v = 40$ . Also, for a 0.1 second peak time, and  $\zeta = 0.456$  (20%

overshoot), Eq. (10.56) yields a required bandwidth of 46.59 rad/s. Using Eq. (10.73), the required phase margin is 48.15°. Let us assume that we raise the phase margin frequency to 39 rad/s. The phase angle of the uncompensated system at this frequency is -158.6°. To obtain the required phase margin, the compensator must contribute 26.75° more at 39 rad/s. Assume the following form for the compensator:  $G_c(s) = K'K_D(s + \frac{1}{K_D})$ . The angle contributed by the compensator is

$$\phi_c = \tan^{-1} \frac{\omega}{1/K_D} = 26.75^\circ. \text{ Letting } \omega = 39 \text{ rad/s, } K_D = 0.0129. \text{ Hence, the compensator is}$$

$G_c(s) = 0.0129(s+77.37)$ . The compensated forward path is

$$G(s) = \frac{144000 * 0.0129(s+77.37)}{s(s+36)(s+100)} = \frac{1857.6(s+77.37)}{s(s+36)(s+100)}$$

The closed-loop bandwidth is approximately 50 rad/s, which meets the requirements.

The lag compensated forward path is

$$G(s) = 7.759 \frac{(s+0.058)}{s(s^2+2s+5)(s+3)(s+0.0015)}$$

16.

a. Bode plots and specifications for gain compensated system are the same as Problem 13. Required phase margin and required bandwidth is the same as Problem 13. Select a phase margin frequency 7 rad/s higher than the bandwidth = 9 + 7 = 16 rad/s. The phase angle at the new phase-margin frequency is -201.6°. The phase contribution required from the compensator is  $-180^\circ + 201.6^\circ + 58.59^\circ = 80.2^\circ$  at the phase-margin frequency. Using the geometry below:

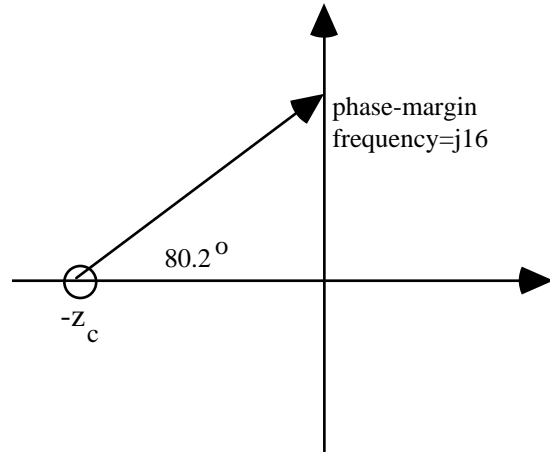

$\tan(80.2) = \frac{16}{z_c}$ . Therefore,  $z_c = 2.76$ . Thus,  $G_c(s) = \frac{1}{2.76}(s + 2.76)$ .

The PD compensated Bode plots:

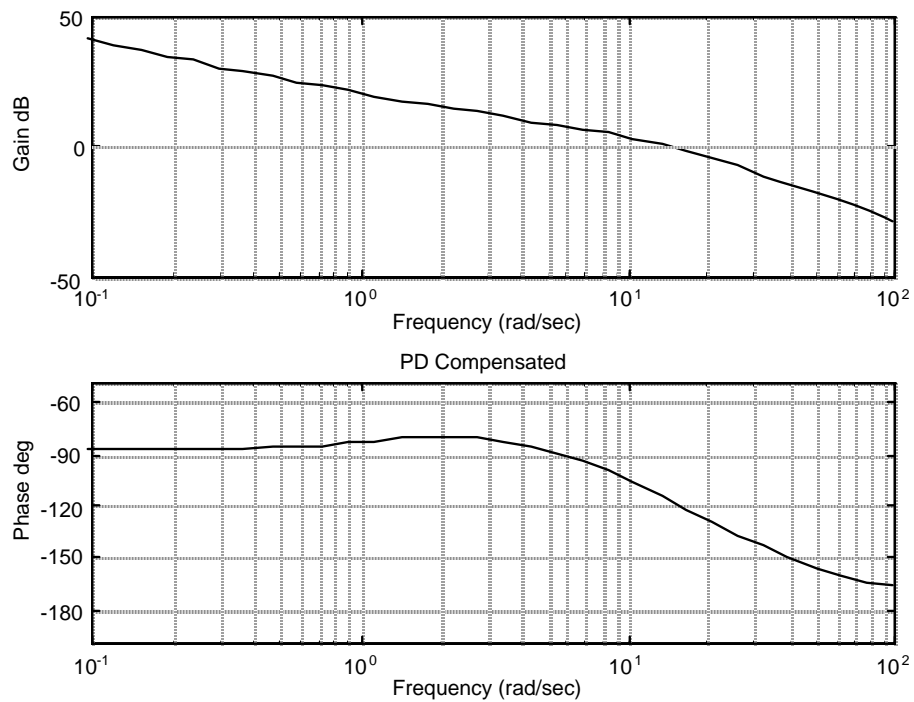

Compensated phase margin is  $62.942^\circ$ .

**b.**

**Program:**

```
numg=1000;
deng=poly([0 -5 -20]);
G=tf(numg,deng);
numc=(1/2.76)*[1 2.76];
denc=1;
Gc=tf(numc,denc);
Ge=G*Gc;
T=feedback(Ge,1);
step(T)
title('PD Compensated')
```

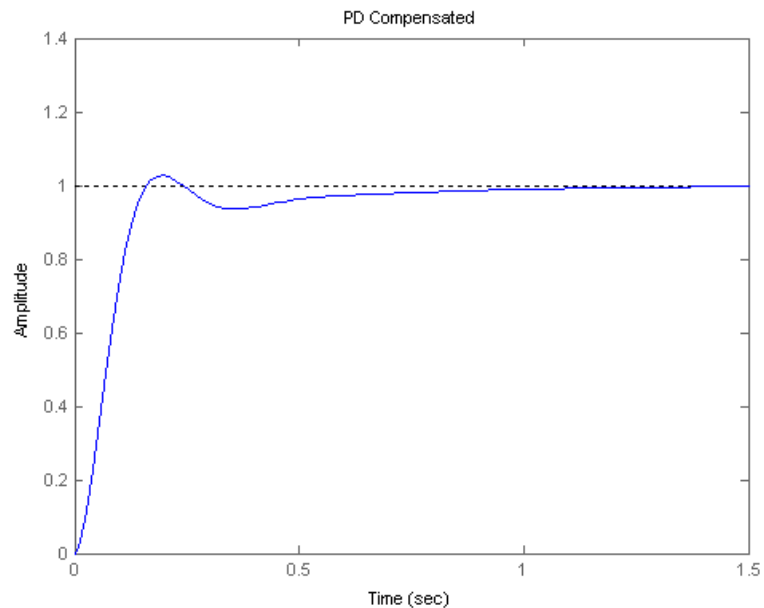
**Computer response:**

17.

**Program:**

```

%Lead Compensator Design via Frequency Response
%Input system
K=input('Type K to meet steady-state error ');
numg=K*[1 1];
deng=poly([0 -2 -6]);
'Open-loop system'
'G(s)'
G=tf(numg,deng)
%Generate uncompensated step response
T=feedback(G,1);
step(T)
title('Gain Compensated')

%Input transient response specifications
Po=input('Type %OS ');
%Ts=input('Type settling time ');
Tp=input('Type peak time ');
%Determine required bandwidth
z=(-log(Po/100))/(sqrt(pi^2+log(Po/100)^2));
%wn=4/(z*Ts);
wn=pi/(Tp*sqrt(1-z^2));
wBW=wn*sqrt((1-2*z^2)+sqrt(4*z^4-4*z^2+2));

%Make a Bode plot and get Bode data
%Get Bode data
bode(G)
title('Gain Compensated')

w=0.01:0.1:100;
[M,P]=bode(numg,deng,w);

%Find current phase margin
[Gm,Pm,wcp,wcg]=margin(M,P,w);

%Calculate required phase margin
z=(-log(Po/100))/(sqrt(pi^2+log(Po/100)^2));
Pmreq=atan(2*z/(sqrt(-2*z^2+sqrt(1+4*z^4))))*(180/pi);

```

```

%Add a correction factor of 10 degrees
Pmreqc=Pmreq+10;

%Calculate phase required from compensator
Pc=Pmreqc-Pm;

%Design lead compensator
%Find compensator beta and peak compensator magnitude
beta=(1-sin(Pc*pi/180))/(1+sin(Pc*pi/180));
magpc=1/sqrt(beta);
%Find frequency at which uncompensated system has a magnitude of 1/magpc
%This frequency will be the new phase margin frequency
for i=1:length(M);
if M(i)-(1/magpc)<=0;
wmax=w(i);
break
end
end
%Calculate the lead compensator's break frequencies
zc=wmax*sqrt(beta);
pc=zc/beta;
Kc=1/beta;
numc=[1 zc];
denc=[1 pc];
'Gc(s)'
Gc=tf(numc,denc)
%Display data
fprintf('\nK = %g',K)
fprintf(' Percent Overshoot = %g',Po)
fprintf(' , Damping Ratio = %g',z)
fprintf(' , Settling Time = %g',Ts)
fprintf(' , Peak Time = %g',Tp)
fprintf(' , Current Phase Margin = %g',Pm)
fprintf(' , Required Phase Margin = %g',Pmreq)
fprintf(' , Required Phase Margin with Correction Factor = %g',Pmreqc)
fprintf(' , Required Bandwidth = %g',wBW)
fprintf(' , Required Phase Contribution from Compensator = %g',Pc)
fprintf(' , Compensator Beta = %g',beta)
fprintf(' , New phase margin frequency = %g',wmax)
fprintf(' Compensator gain, Kc = %g',Kc)
fprintf(' Compensator zero, = %g',-zc)
fprintf(' Compensator pole, = %g',-pc)
'G(s)Gc(s)'
Ge=G*Kc*Gc
pause
%Generate compensated Bode plots
%Make a Bode plot and get Bode data
%Get Bode data
bode(Ge)
title('Lead Compensated')

w=0.01:0.1:1000;
[M,P]=bode(Ge,w);
%Find compensated phase margin
[Gm,Pm,wcp,wcg]=margin(M,P,w);
fprintf('\nCompensated Phase Margin, = %g',Pm)
pause
%Generate step response
T=feedback(Ge,1);
step(T)
title('Lead Compensated')

```

**Computer response:**

Type K to meet steady-state error 360

ans =



11-34 Chapter 11: Design via Frequency Response

Open-loop system

ans =

G(s)

Transfer function:

$$\frac{360 s + 360}{s^3 + 8 s^2 + 12 s}$$

-----  
s^3 + 8 s^2 + 12 s

Type %OS 10

Type peak time 0.1

ans =

Gc(s)

Transfer function:

$$\frac{s + 11.71}{s + 77.44}$$

-----  
s + 77.44

K = 360 Percent Overshoot = 10, Damping Ratio = 0.591155, Peak Time = 0.1,  
Current Phase Margin = 21.0851, Required Phase Margin = 58.5931, Required  
Phase Margin with Correction Factor = 68.5931, Required Bandwidth =  
45.1795, Required Phase Contribution from Compensator = 47.508, Compensator  
Beta = 0.151164, New phase margin frequency = 30.11 Compensator gain, Kc =  
6.61532 Compensator zero, = -11.7067 Compensator pole, = -77.4437

ans =

G(s)Gc(s)

Transfer function:

$$\frac{2382 s^2 + 3.026e004 s + 2.788e004}{s^4 + 85.44 s^3 + 631.5 s^2 + 929.3 s}$$

-----  
s^4 + 85.44 s^3 + 631.5 s^2 + 929.3 s

Compensated Phase Margin, = 60.676»

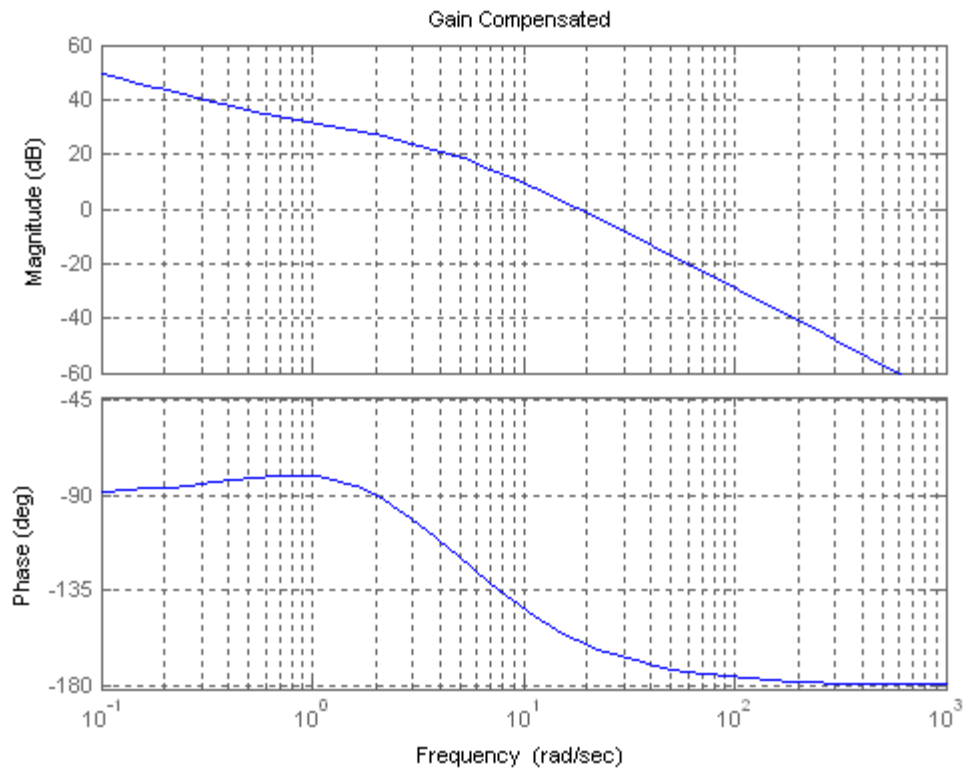
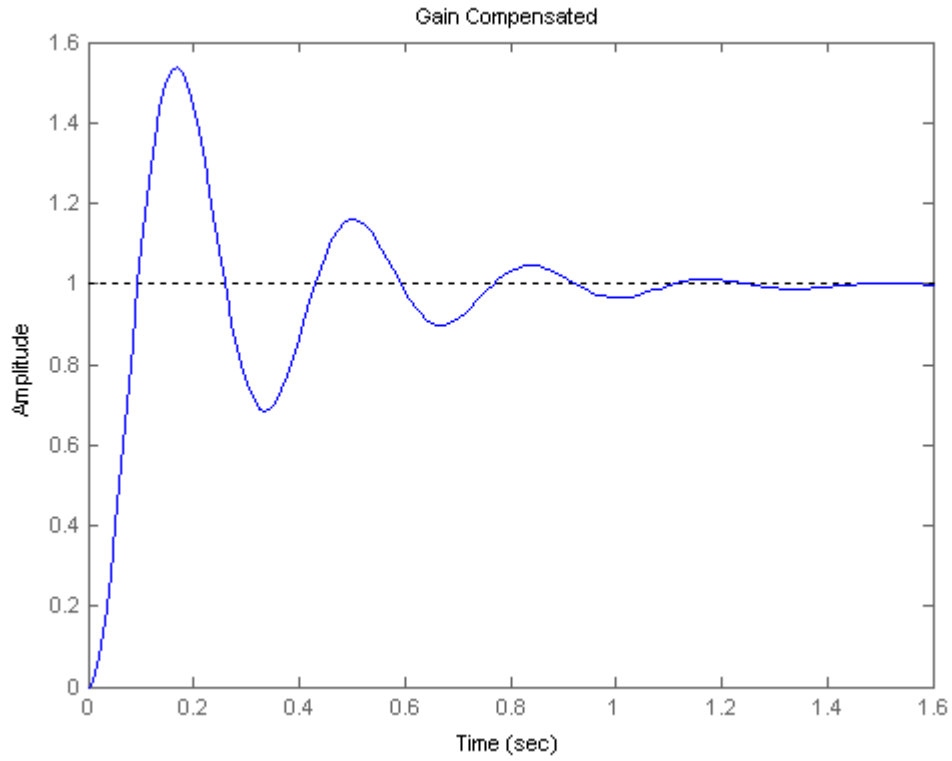

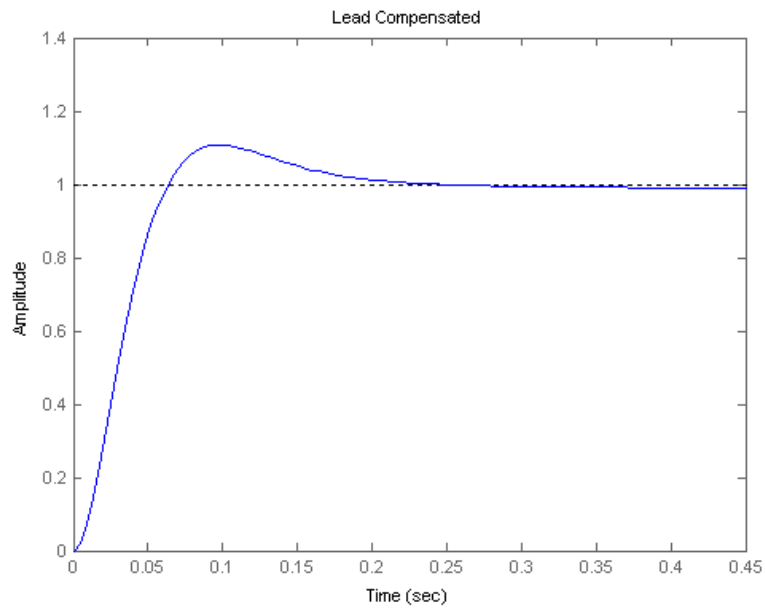
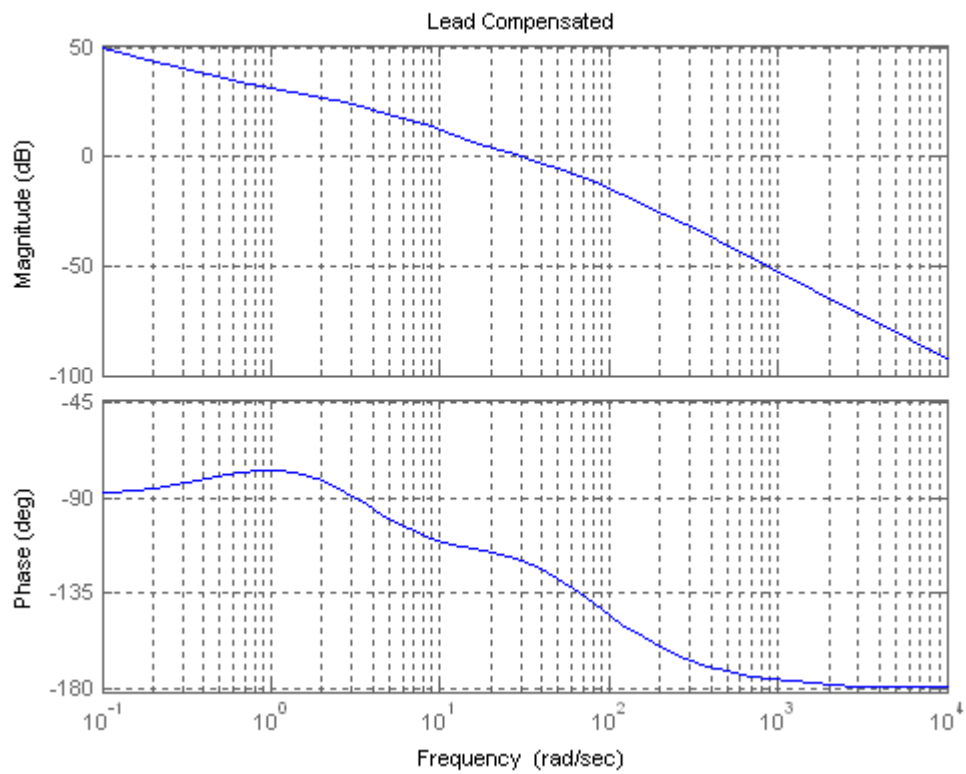

18.

**Program:**

```

%PD Compensator Design via Frequency Response
    %Input system
%Uncompensated system
K=input('Type K to meet steady-state error ');
numg=K*[1 1];
deng=poly([0 -2 -6]);
G=tf(numg,deng);
T=feedback(G,1);
step(T)
title('Gain Compensated')
'Open-loop system'
'G(s)'
Gzpk=zpk(G)

    %Input transient response specifications
Po=input('Type %OS ');
%Ts=input('Type settling time ');
Tp=input('Type peak time ');

    %Determine required bandwidth
z=(-log(Po/100))/(sqrt(pi^2+log(Po/100)^2));
%wn=4/(z*Ts);
wn=pi/(Tp*sqrt(1-z^2));
wBW=wn*sqrt((1-2*z^2)+sqrt(4*z^4-4*z^2+2));

    %Make a Bode plot and get Bode data
%Get Bode data
bode(G)
title('Gain Compensated')
w=0.01:0.1:100;
[M,P]=bode(G,w);

    %Find current phase margin
[Gm,Pm,wcp,wcg]=margin(M,P,w);

    %Calculate required phase margin
z=(-log(Po/100))/(sqrt(pi^2+log(Po/100)^2));
Pmreq=atan(2*z/(sqrt(-2*z^2+sqrt(1+4*z^4))))*(180/pi)+20;

    %Determine a phase margin frequency
wpm=wBW*7;
    %Find phase angle at new phase margin frequency and

    %calculate phase required from the compensator
for i=1:length(w);
if w(i)-wpm>=0;
wpm=w(i);
Pwpm=P(i);
break
end
end

    %Design PD compensator
Pc=Pmreq-(180+Pwpm);
zc=wpm/tan(Pc*pi/180);
Kc=1/zc;
numc=Kc*[1 zc];
denc=1;
'Gc(s)'
Gc=tf(numc,denc);
Gczpk=zpk(Gc)

    %Display data
fprintf('\nK = %g',K)
fprintf(' Percent Overshoot = %g',Po)
fprintf(', Damping Ratio = %g',z)
fprintf(', Settling Time = %g',Ts)

```

```

fprintf(' Peak Time = %g',Tp)
fprintf(' Current Phase Margin = %g',Pm)
fprintf(' Required Phase Margin = %g',Pmreq)
fprintf(' Required Bandwidth = %g',wBW)
fprintf(' New phase margin frequency = %g',wpm)
fprintf(' Phase angle at new phase margin frequency = %g',Pwpm)
fprintf(' Required Phase Contribution from Compensator = %g',Pc)
fprintf(' Compensator gain, Kc = %g',Kc)
fprintf(' Compensator zero, = %g',-zc)

pause

%Generate compensated Bode plots
%Make a Bode plot and get Bode data
%Get Bode data
'G(s)Gc(s)'
Ge=G*Gc;
Gezpk=zpk(Ge)
bode(Ge)
title('PD Compensated')
w=0.01:0.1:100;
[M,P]=bode(Ge,w);
%Find compensated phase margin
[Gm,Pm,wcp,wcg]=margin(M,P,w);
fprintf('\nCompensated Phase Margin, = %g',Pm)
pause

%Generate step response
T=feedback(Ge,1);
step(T)
title('PD Compensated')

```

**Computer response:**

Type K to meet steady-state error 360

ans =

Open-loop system

ans =

G(s)

Zero/pole/gain:

360 (s+1)

-----  
s (s+6) (s+2)

Type %OS 10

Type peak time 0.1

ans =

Gc(s)

Zero/pole/gain:

0.05544 (s+18.04)

K = 360 Percent Overshoot = 10, Damping Ratio = 0.591155, Peak Time = 0.1,  
Current Phase Margin = 21.0851, Required Phase Margin = 78.5931, Required  
Bandwidth = 45.1795, New phase margin frequency = 52.21, Phase angle at new  
phase margin frequency = -172.348, Required Phase Contribution from  
Compensator = 70.9409 Compensator gain, Kc = 0.0554397 Compensator zero, =  
-18.0376

ans =

$G(s)G_c(s)$

Zero/pole/gain:  
 19.9583 (s+18.04) (s+1)  
 -----  
 s (s+6) (s+2)

Compensated Phase Margin, = 69.546

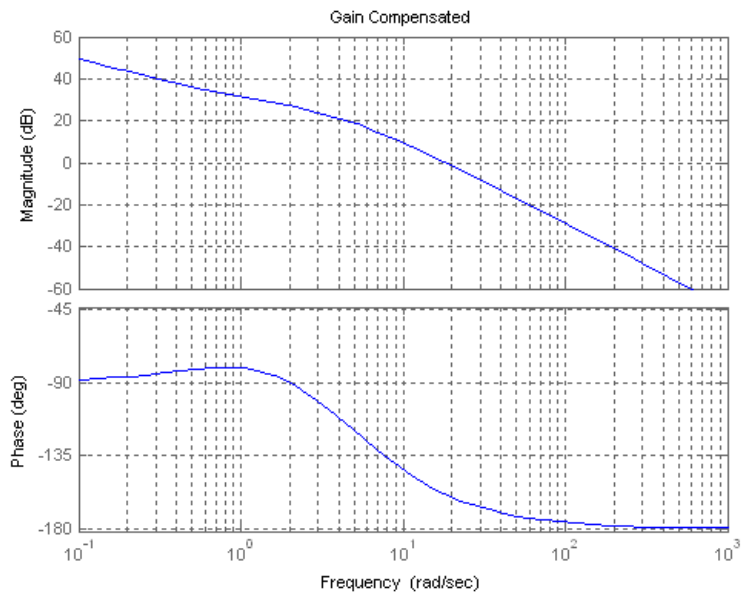
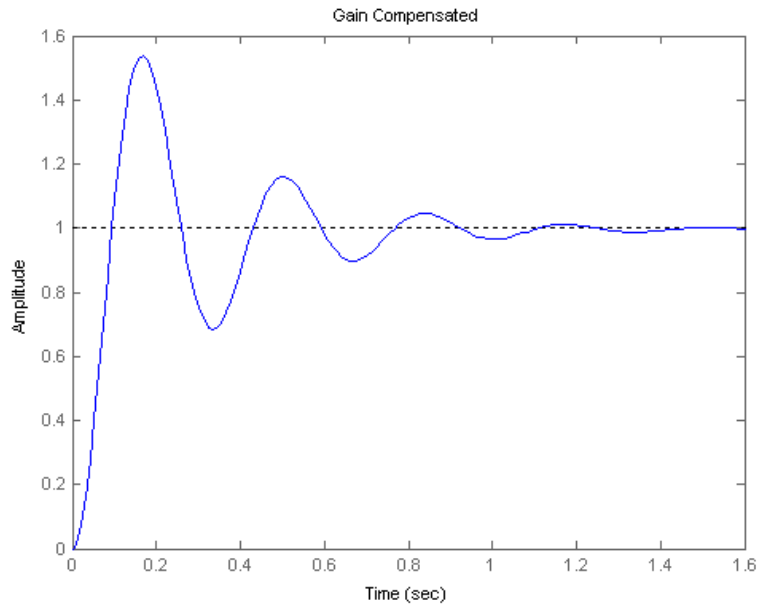

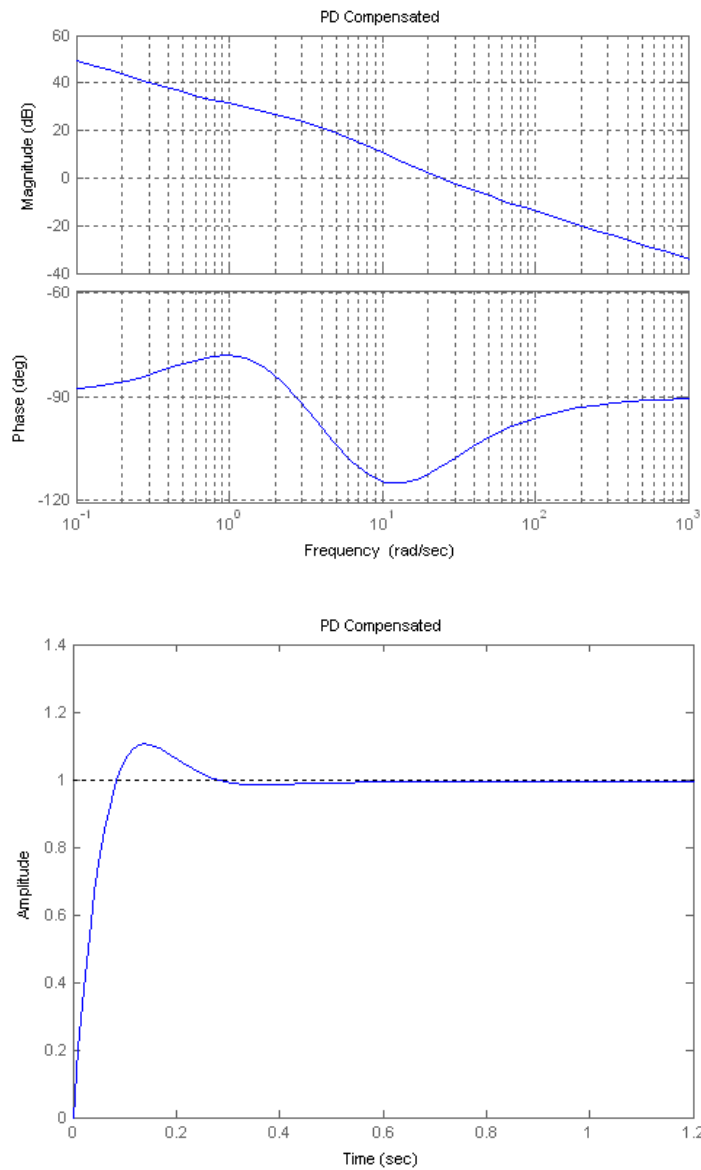

19.

$K = 10714$  for  $K_V = 1000$ .  $\zeta = 0.517$  for 15% overshoot using Eq. (4.39). Using Eq. (4.42),  $\omega_n = 77.37$ . Using Eq. (10.54) the required bandwidth,  $\omega_{BW} = 96.91$ . Using Eq. (10.73) with  $5^\circ$  additional,  $\Phi_m = 58.17^\circ$ . Choose the new phase-margin frequency  $\omega_{PM} = 0.8 \omega_{BW} = 77.53$ . Plotting the Bode plots for  $K = 10714$ ,

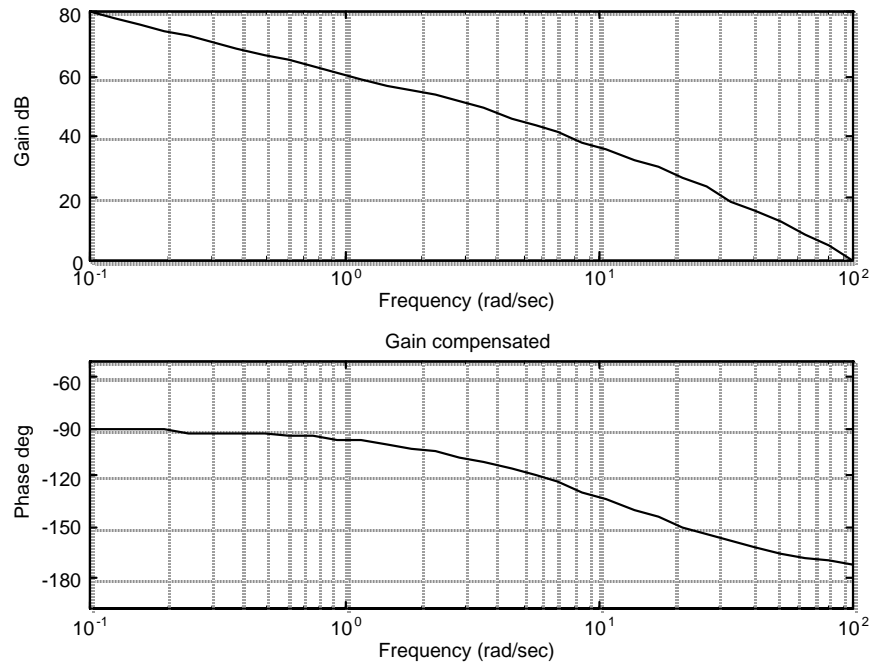

At the new phase-margin frequency, the phase angle is  $-170.52$ . Thus, the contribution from the lead is  $58.17 - (180 - 170.52) = 48.69^\circ$ . Using Eq. (11.11),  $\beta = 0.142$ .

Lag compensator design:  $z_{\text{clag}} = \omega_{\text{Pm}}/10 = 77.53/10 = 7.753$ .  $p_{\text{clag}} = z_{\text{clag}} \cdot \beta = 1.102$ .  $K_{\text{clag}} =$

$p_{\text{clag}}/z_{\text{clag}} = 0.1421$ . Thus,  $G_{\text{lag}}(s) = 0.1421 \frac{s+7.753}{s+1.102}$ .

Lead compensator design: Using Eqs. (11.6), (11.9), and (11.12)  $z_{\text{lead}} = 1/T = \omega_{\text{Pm}} \cdot \sqrt{\beta} = 29.22$ .

$p_{\text{lead}} = z_{\text{lead}}/\beta = 205.74$ .  $K_{\text{lead}} = p_{\text{lead}}/z_{\text{lead}} = 7.04$ . Thus,  $G_{\text{lead}}(s) = 7.04 \frac{s+29.22}{s+205.74}$ .

20.

**Program:**

```
%Lag-Lead Compensator Design via Frequency Response
%Input system
K=input('Type K to meet steady-state error ');
numg=K*[1 7];
deng=poly([0 -5 -15]);
G=tf(numg,deng);
'G(s)'
Gzpk=zpk(G)

%Input transient response specifications
Po=input('Type %OS ');
Ts=input('Type settling time ');
%Tp=input('Type peak time ');
T=feedback(G,1);
step(T)
title('Gain Compensated')
pause

%Determine required bandwidth
z=(-log(Po/100))/(sqrt(pi^2+log(Po/100)^2));
wn=4/(z*Ts);
%wn=pi/(Tp*sqrt(1-z^2));
```



```

wBW=wn*sqrt((1-2*z^2)+sqrt(4*z^4-4*z^2+2));
%wBW=(4/(Ts*z))*sqrt((1-2*z^2)+sqrt(4*z^4-4*z^2+2));
%wBW=(pi/(Tp*sqrt(1-z^2)))*sqrt((1-2*z^2)+sqrt(4*z^4-4*z^2+2));

%Determine required phase margin
Pmreq=atan(2*z/(sqrt(-2*z^2+sqrt(1+4*z^4))))*(180/pi)+5;

%Choose new phase margin frequency
wpm=0.8*wBW;

%Determine additional phase lead required at the
%new phase margin frequency from the lead compensator
[M,P]=bode(G,wpm);
Pmreqc=Pmreq-(180+P);
beta=(1-sin(Pmreqc*pi/180))/(1+sin(Pmreqc*pi/180));
%Display data
fprintf('\nPercent Overshoot = %g',Po)
fprintf(' , Settling Time = %g',Ts)
%fprintf(' , Peak Time = %g',Tp)
fprintf(' , Damping Ratio = %g',z)
fprintf(' , Required Phase Margin = %g',Pmreq)
fprintf(' , Required Bandwidth = %g',wBW)
fprintf(' , New Phase Margin Frequency = %g',wpm)
fprintf(' , Required Phase from Lead Compensator = %g',Pmreqc)
fprintf(' , Beta = %g',beta)
bode(numg,deng)
title('Gain compensated')
pause

%Design lag compensator
zclag=wpm/10;
pclag=zclag*beta;
Kclag=beta;
'Lag compensator'
'Gclag'
Gclag=tf(Kclag*[1 zclag],[1 pclag]);
Gclagzpk=zpk(Gclag)

%Design lead compensator
zlead=wpm*sqrt(beta);
plead=zlead/beta;
Klead=1/beta;
'Lead compensator'
'Gclead'
Gclead=tf(Klead*[1 zlead],[1 plead]);
Gcleadzpk=zpk(Gclead)

%Create compensated forward path
'Gclag(s)Gclead(s)G(s)'
Ge=G*Gclag*Gclead;
Gezpk=zpk(Ge)

%Test lag-lead compensator
T=feedback(Ge,1);
bode(Ge)
title('Lag-lead Compensated')
[M,P,w]=bode(Ge);
[Gm,Pm,wcp,wcg]=margin(M,P,w);
'Compensated System Results'
fprintf('\nResulting Phase Margin = %g',Pm)
fprintf(' , Resulting Phase Margin Frequency = %g',wcp)
pause
step(T)
title('Lag-lead Compensated')

```

**Computer response:**

Type K to meet steady-state error 10714.29

ans =

G(s)

```
Zero/pole/gain:
10714.29 (s+7)
-----
s (s+15) (s+5)
```

```
Type %OS 15
Type settling time 0.1
```

```
Percent Overshoot = 15, Settling Time = 0.1, Damping Ratio = 0.516931,
Required Phase Margin = 58.1718, Required Bandwidth = 96.9143, New Phase
Margin Frequency = 77.5314, Required Phase from Lead Compensator = 48.6912,
Beta = 0.142098
ans =
```

```
Lag compensator
```

```
ans =
```

```
Gclag
```

```
Zero/pole/gain:
0.1421 (s+7.753)
-----
(s+1.102)
```

```
ans =
```

```
Lead compensator
```

```
ans =
```

```
Gclead
```

```
Zero/pole/gain:
7.0374 (s+29.23)
-----
(s+205.7)
```

```
ans =
```

```
Gclag(s)Gclead(s)G(s)
```

```
Zero/pole/gain:
10714.29 (s+29.23) (s+7.753) (s+7)
-----
s (s+205.7) (s+15) (s+5) (s+1.102)
```

```
ans =
```

```
Compensated System Results
```

```
Resulting Phase Margin = 53.3994, Resulting Phase Margin Frequency =
55.5874
```

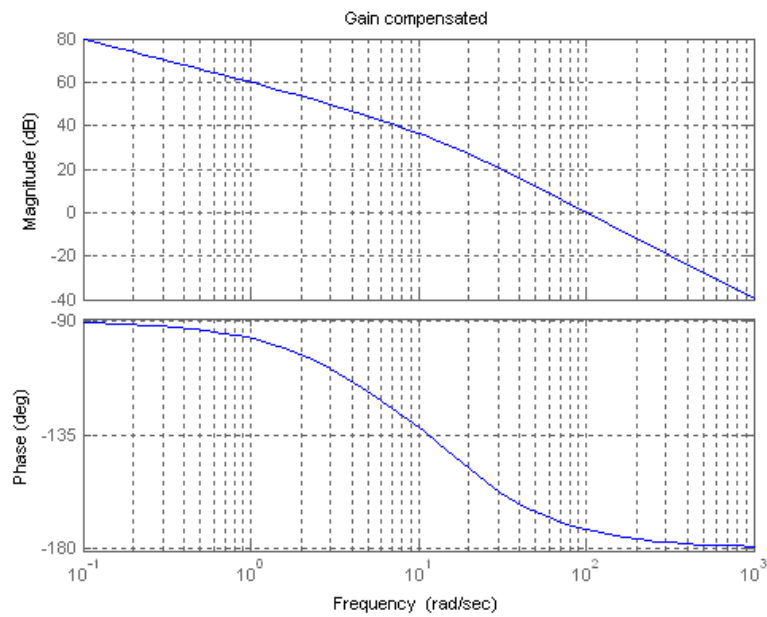
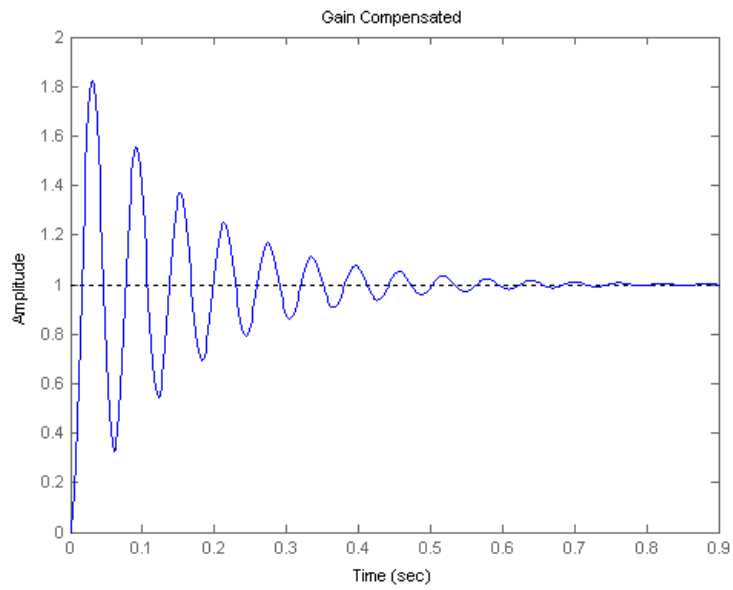

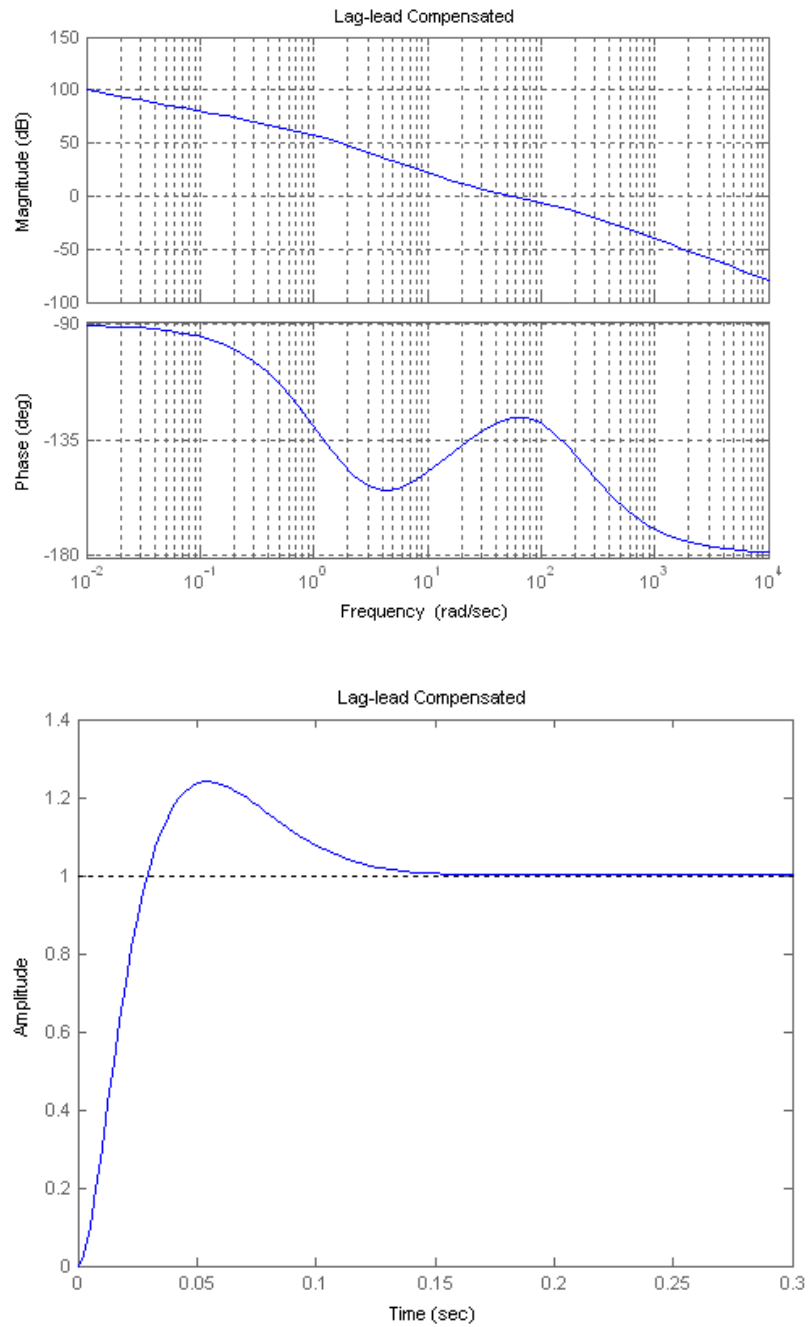

Percent overshoot exceeds requirements. Redesign if required.

21.

The required bandwidth for a peak time of 2 seconds and  $\zeta = 0.456$  (i.e. 20% overshoot) is 2.3297 rad/s. Plotting the Bode diagrams for  $K = 1$ ,

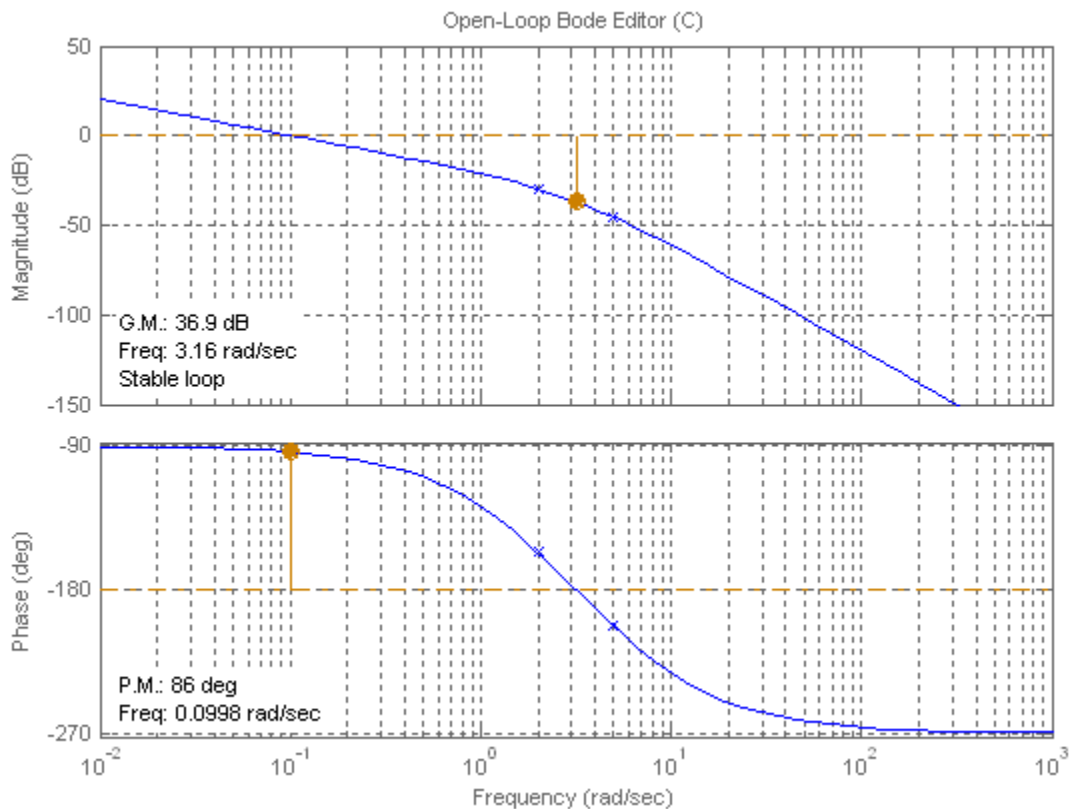

For 20% overshoot,  $\Phi_M = 48.15^\circ$ , or a phase angle of  $-180^\circ + 48.15^\circ = -131.85^\circ$ . This angle occurs at 1.12 rad/s. If  $K = 13.1$ , the magnitude curve will intersect zero dB at 1.12 rad/s. Thus, the following

$$\text{function yields 20\% overshoot: } G(s) = \frac{13.1}{s(s+2)(s+5)}.$$

**PI controller design:** Allowing for a  $5^\circ$  margin, we want  $\Phi_M = 48.15^\circ + 5^\circ = 53.15^\circ$ , or a phase angle of  $-180^\circ + 53.15^\circ = -126.85^\circ$ . This angle occurs at  $\omega = 0.97$  rad/s where the magnitude curve is 1.5321 dB. The controller should contribute -1.5321 dB so that the magnitude curve passes through 0 dB at  $\omega = 0.97$  rad/s. Choosing the break frequency one decade below the phase margin frequency of 0.97 rad/s, and adjusting the controller's gain to yield -1.5321 dB at high frequencies, the ideal integral controller is

$$G_{cPI}(s) = \frac{1.198(s+0.097)}{s}$$

and the PI compensated forward path is

$$G_{PI}(s) = G(s)G_{cPI}(s) = \frac{15.694(s+0.097)}{s^2(s+2)(s+5)}$$

Plotting the Bode diagram for the PI compensated system yields,

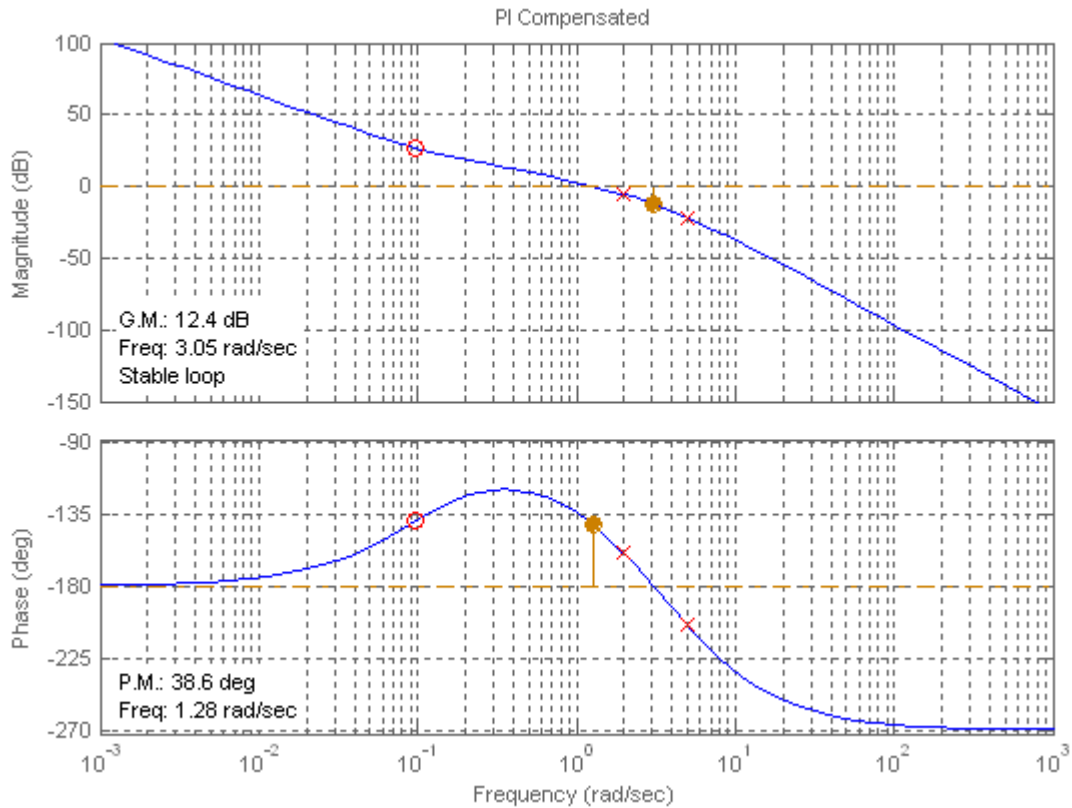

This function is zero dB at  $\omega = 1.28$  rad/s. The phase at this frequency is  $-141.4^\circ$ . Thus, we have a phase margin of  $38.6^\circ$ .

**PID controller design:** Let us increase the phase margin frequency to 4 rad/s. At this frequency the phase is  $-193.48^\circ$ . To obtain the required phase margin of  $48.15^\circ$  the phase curve must be raised an additional  $61.63^\circ$ . Assume the following form for the compensator:  $G_{cPD}(s) = K'K_D(s + \frac{1}{K_D})$ . The

angle contributed by the compensator is  $\phi_c = \tan^{-1} \frac{\omega}{1/K_D} = 61.63^\circ$ . Letting  $\omega = 4$  rad/s,  $K_D = 0.463$ .

Hence, the compensator is  $G_{cPD}(s) = 0.463K'(s + 2.16)$ . The final PID compensated forward path is

$$G_{PID}(s) = G_{PI}(s)G_{cPD}(s) = \frac{15.694(s + 0.097)}{s^2(s + 2)(s + 5)} * 0.463K'(s + 2.16) = \frac{2.266K'(s + 0.097)(s + 2.16)}{s^2(s + 2)(s + 5)}$$

Letting  $K' = 1$  the magnitude of this function at 4 rad/s is  $-20.92$  dB. Thus,  $K'$  must be adjusted to bring the magnitude to zero dB. Hence,  $K' = 11.12$  (20.92 dB).

Thus,

$$G_{PID}(s) = \frac{25.2(s + 0.097)(s + 2.16)}{s^2(s + 2)(s + 5)}$$

The PID compensated Bode plot follows:

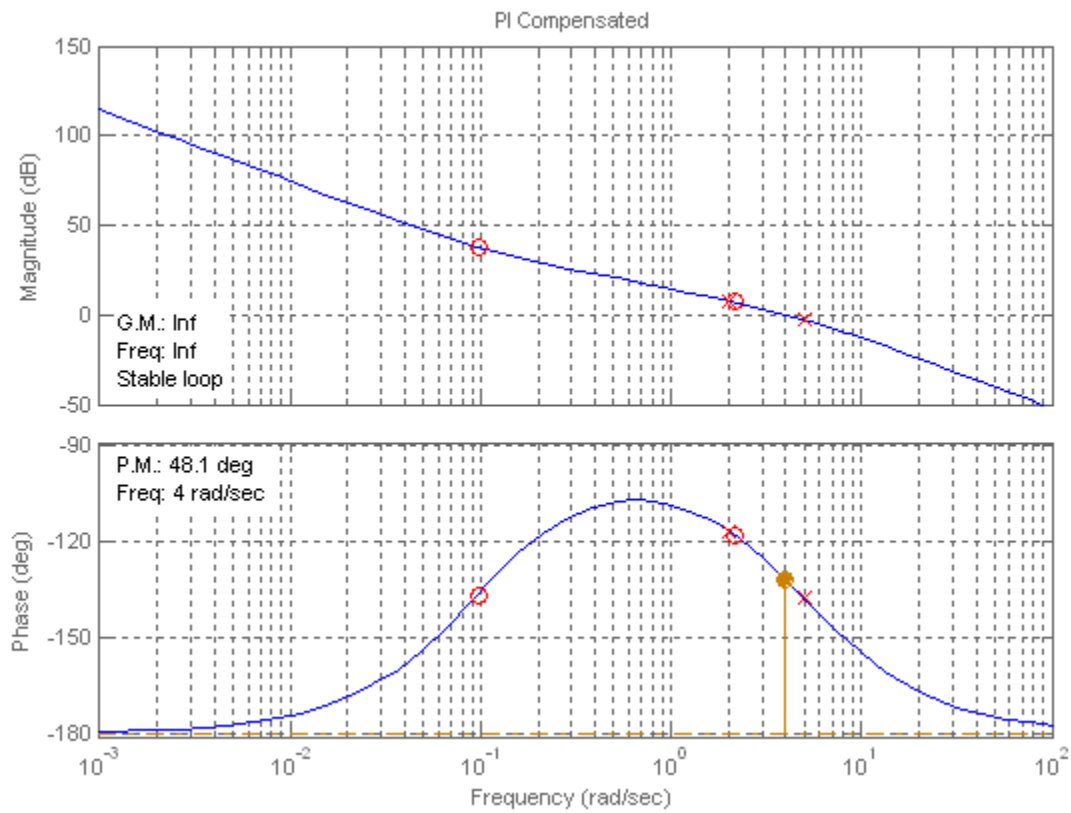

The PID compensated time response is shown below:

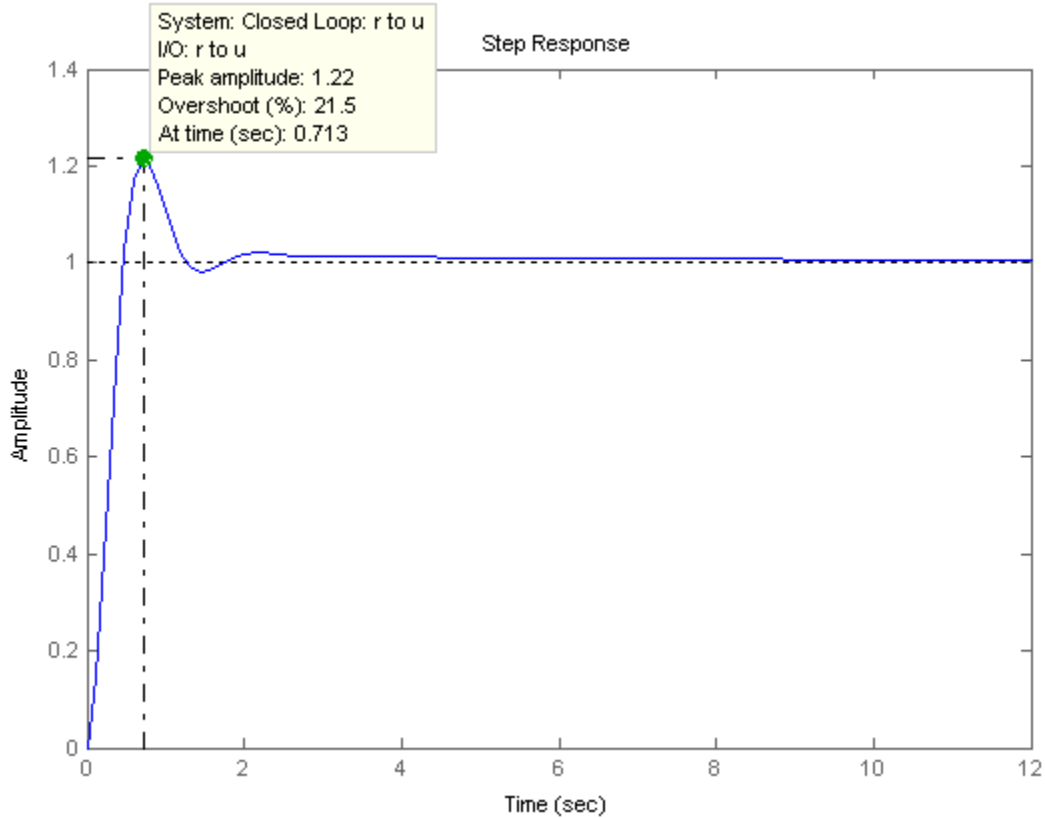

22.

**Program:**

```
%Input system
numg1=1;
deng1=poly([0 -3 -6]);
G1=tf(numg1,deng1);
[numg2,deng2]=pade(0.5,5);
G2=tf(numg2,deng2);
'G(s)=G1(s)G2(s)'
G=G1*G2;
Gzpk=zpk(G)
Tu=feedback(G,1);
step(Tu)
title('K = 1')
%Percent Overshoot to Damping Ratio to Phase Margin
Po=input('Type %OS ');
z=(-log(Po/100))/(sqrt(pi^2+log(Po/100)^2));
Pm=atan(2*z/(sqrt(-2*z^2+sqrt(1+4*z^4))))*(180/pi);
fprintf('\nPercent Overshoot = %g',Po)
fprintf(', Damping Ratio = %g',z)
fprintf(', Phase Margin = %g',Pm)
%Get Bode data
bode(G)
title('K = 1')
pause
w=0.1:0.01:100;
[M,P]=bode(G,w);
Ph=-180+Pm;
for i=1:length(P);
if P(i)-Ph<=0;
M=M(i);
K=1/M;
end
end
```



```

fprintf(' Frequency = %g',w(i))
fprintf(' Phase = %g',P(i))
fprintf(' Magnitude = %g',M)
fprintf(' Magnitude (dB) = %g',20*log10(M))
fprintf(' K = %g',K)
break
end
end
T=feedback(K*G,1);
step(T)
title('Gain Compensated')

```

**Computer response:**

ans =

$$G(s)=G1(s)G2(s)$$

Zero/pole/gain:

$$\frac{-(s-14.59)(s^2 - 26.82s + 228.4)(s^2 - 18.6s + 290.5)}{s(s+14.59)(s+6)(s+3)(s^2 + 26.82s + 228.4)(s^2 + 18.6s + 290.5)}$$

Type %OS 20

Percent Overshoot = 20, Damping Ratio = 0.45595, Phase Margin = 48.1477,  
 Frequency = 0.74, Phase = -132.087, Magnitude = 0.0723422, Magnitude (dB)  
 = -22.8122, K = 13.8232»

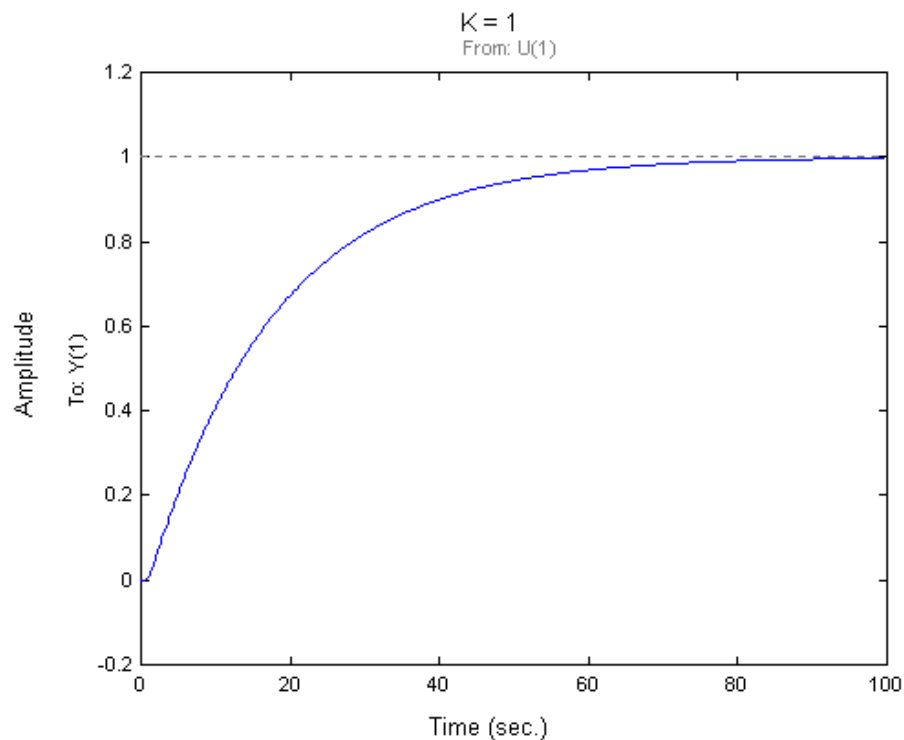

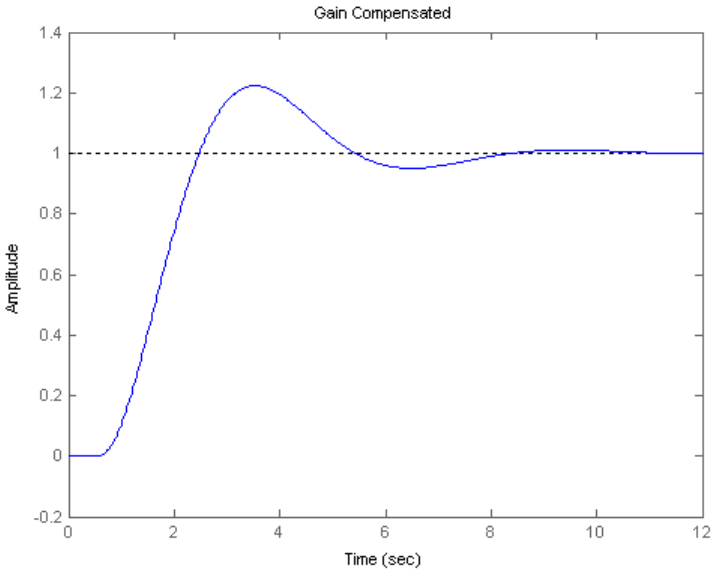
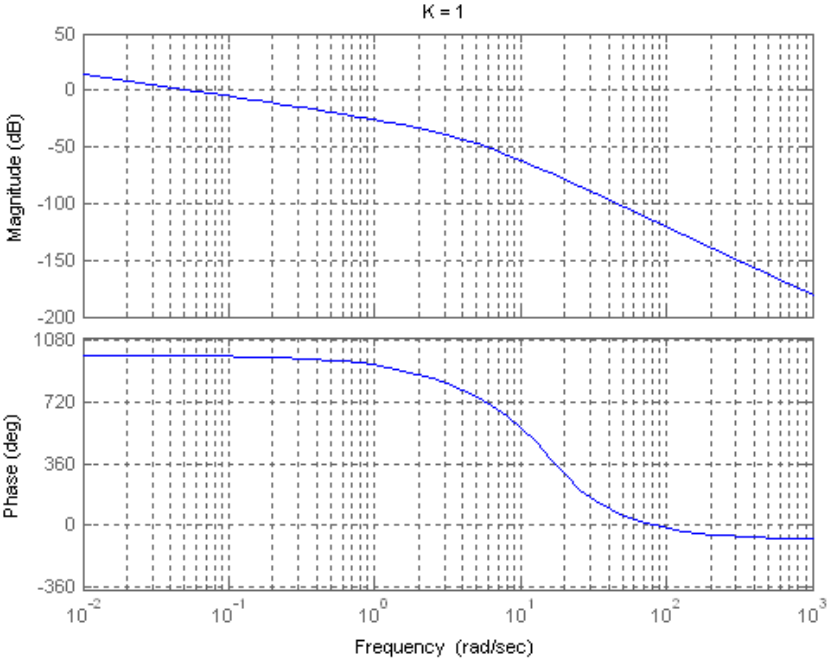

Second-order approximation not valid.

## SOLUTIONS TO DESIGN PROBLEMS

23.

a. Plot the Bode plot for  $K = 1$ .

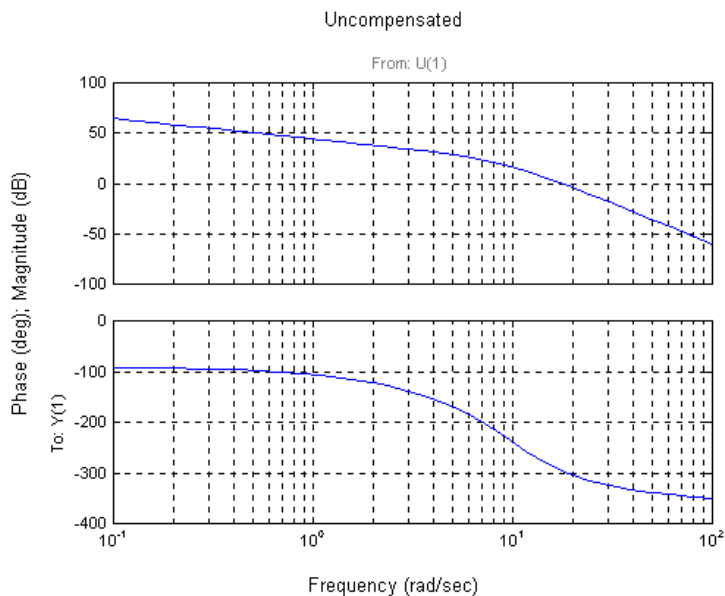

Using Eqs. (4.39) and (10.73) a percent overshoot = 10 is equivalent to a  $\zeta = 0.591$  and  $\phi_M = 58.59^\circ$ .

The phase-margin frequency = 1.933 rad/s where the phase is  $58.59^\circ - 180^\circ = -121.41^\circ$ . The magnitude = 38.37 dB, or 82.85. Hence  $K = 1/82.85 = 0.01207$ .

b. Plot the gain-compensated Bode plot ( $K = 0.01207$ ).

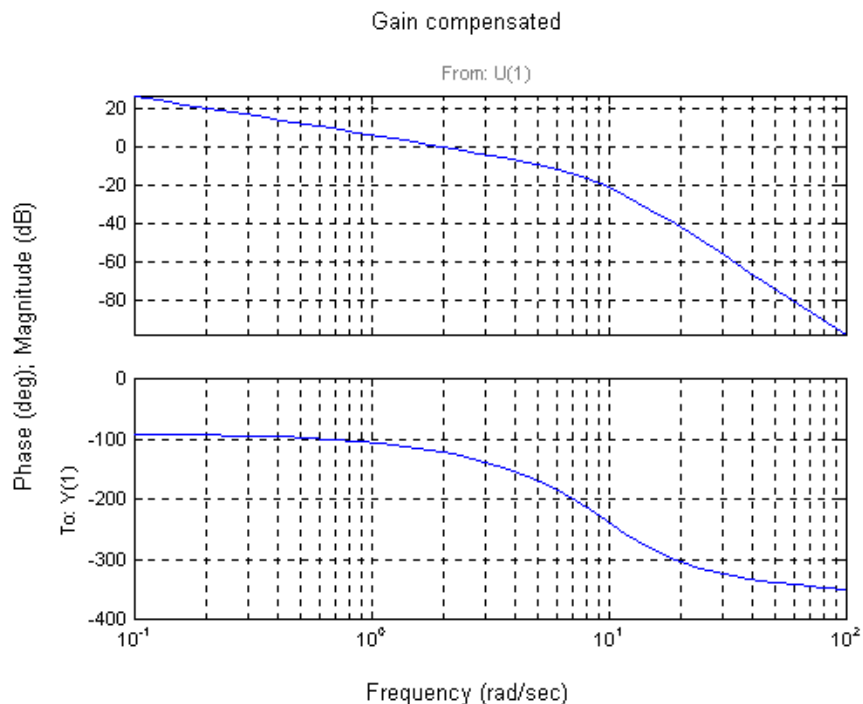

The bandwidth,  $\omega_{BW}$ , is the frequency at which the magnitude is  $-7\text{dB}$ . From the compensated plots, this frequency is  $3.9\text{ rad/s}$ . Eq. (10.55),  $T_s = 2.01\text{ s}$ . Using Eq. (10.57),  $T_p = 1.16\text{ s}$ .

c.

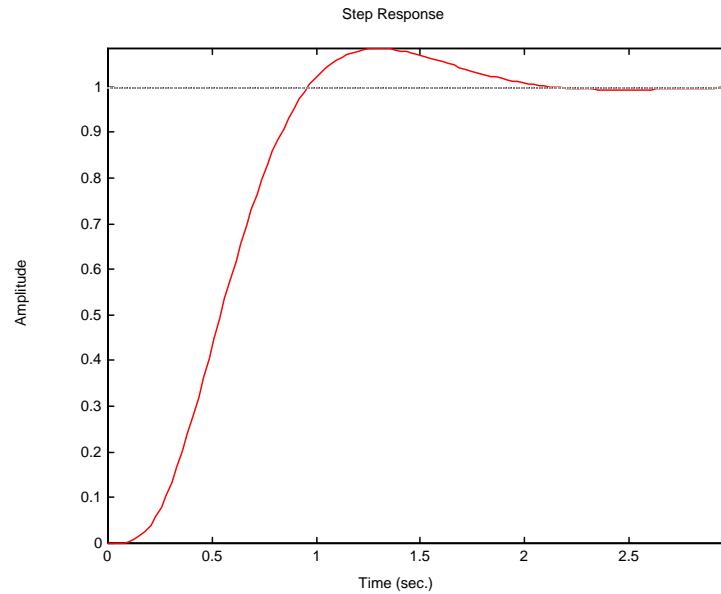

24.

a. The bode plot for the open loop transmission is obtained and shown next:

```
>> syms s
>> s=tf('s');
>> M=0.005/(s+0.005);
>> P=140625/(s+2.67)/(s+10);
>> set(P,'inputdelay',0.1)
>> L=M*P
```

Transfer function:

$$703.1 \frac{\exp(-0.1*s)}{s^3 + 12.68 s^2 + 26.76 s + 0.1335}$$

```
>> bode(L)
```

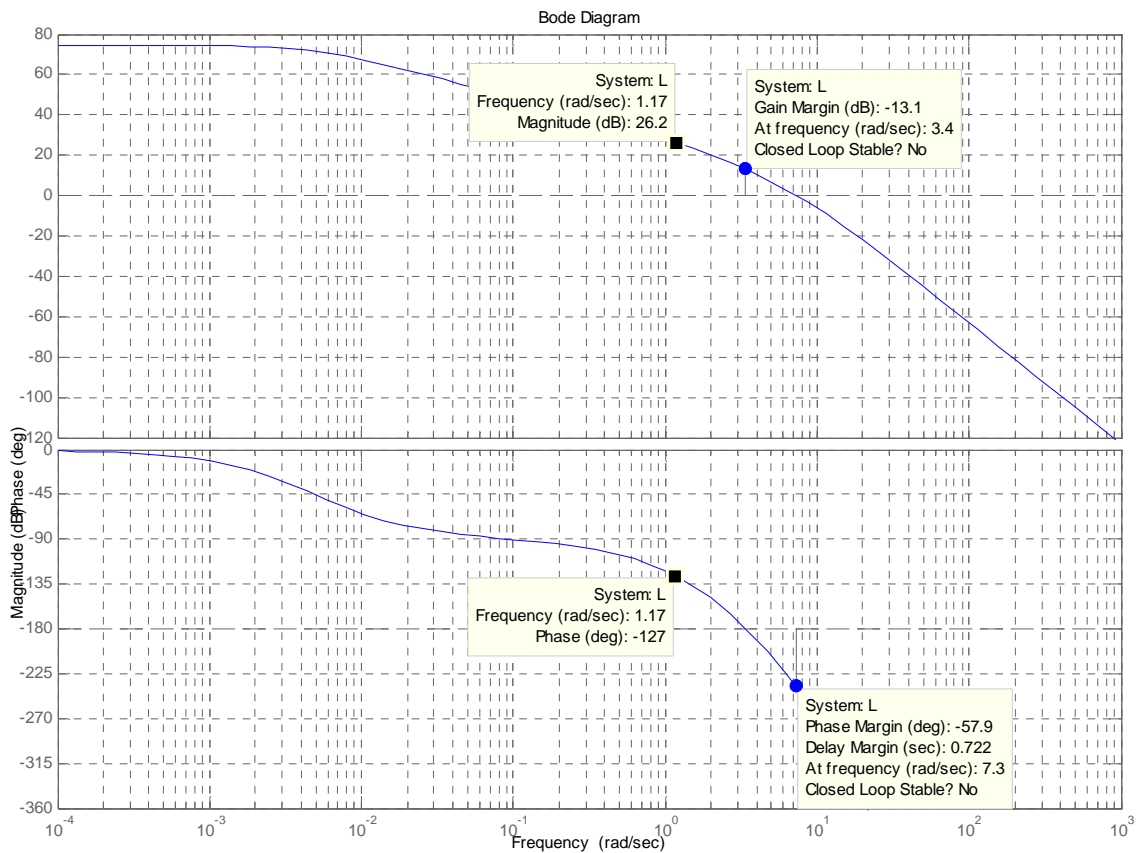

It can be seen that with  $L = 1$ , the system is closed loop unstable. The desired %OS=15% corresponds to a damping factor of  $\zeta = \frac{-\ln(\%OS/100)}{\sqrt{\pi^2 + \ln^2(\%OS/100)}} = 0.517$ . In turn this corresponds to a phase margin of  $\Phi_M = \tan^{-1} \frac{2\zeta}{\sqrt{-2\zeta^2 + \sqrt{1 + 4\zeta^4}}} = 53.2^\circ$ . For this to occur the open loop transmission must have a phase of  $-180^\circ + 53.2^\circ = -126.8^\circ$  at the point where the open loop transmission has a magnitude of 0db. The open loop transmission attains this phase when  $\omega = 1.17$  rad/sec, and at that frequency the open loop transmission has a magnitude of 26.2db. So the open loop transmission must be decreased by this amount resulting in  $L = 0.049$ .

b.

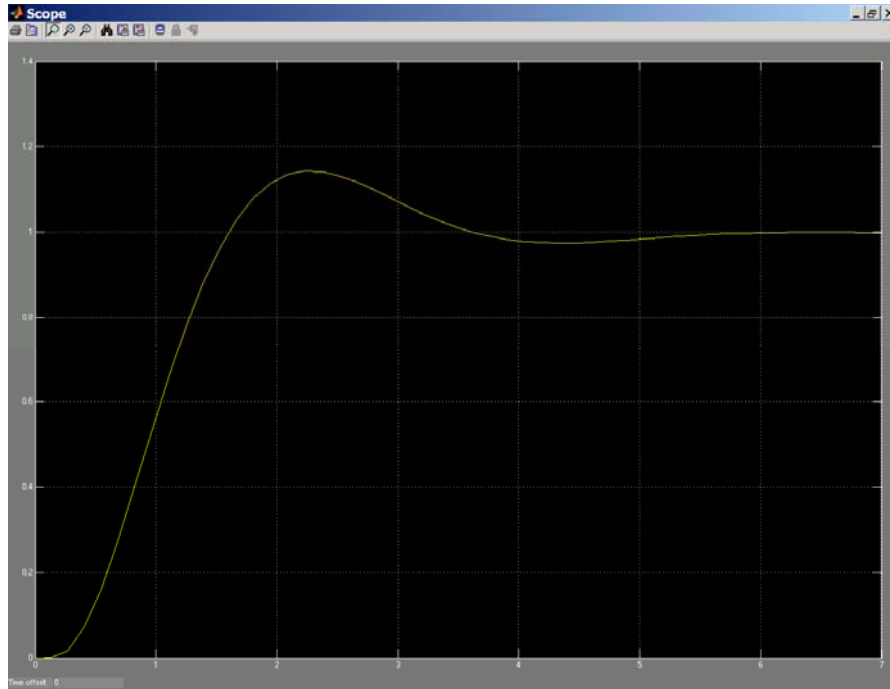
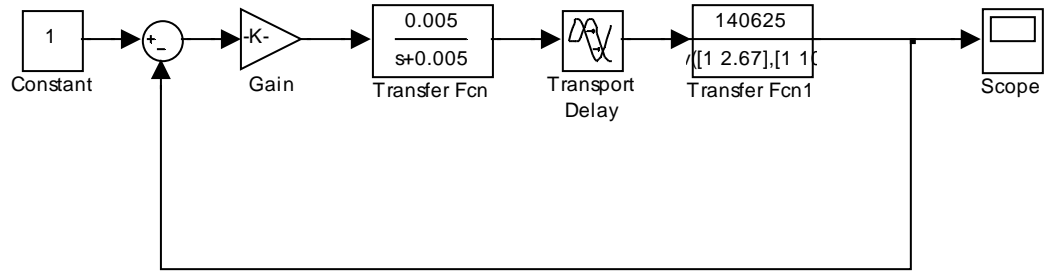

The figure shows a %OS slightly smaller than 15%.

25.

a. We calculate  $e_{ss}$  for step inputs in the uncompensated system.  $K_p = \lim_{s \rightarrow 0} G(s) = 19.21$ , so

$e_{ss} = \frac{1}{1 + K_p} = 0.05$ . The uncompensated phase margin can also be obtained through a bode plot and is of  $77.3^\circ$ .

A tenfold improvement in steady state error requires multiplying the open loop gain by 10. The resulting open loop transfer function frequency response is shown in the following bode plot. The desired phase margin for the design will be  $77.3^\circ + 10^\circ = 87.3^\circ$ . It can be seen there that this phase value is achieved when  $\omega = 10.1 \frac{\text{rad}}{\text{sec}}$ . At this point the magnitude of the open loop transmission is 25.8db. So the lag compensator must provide -25.8db at  $\omega = 10.1 \frac{\text{rad}}{\text{sec}}$ .

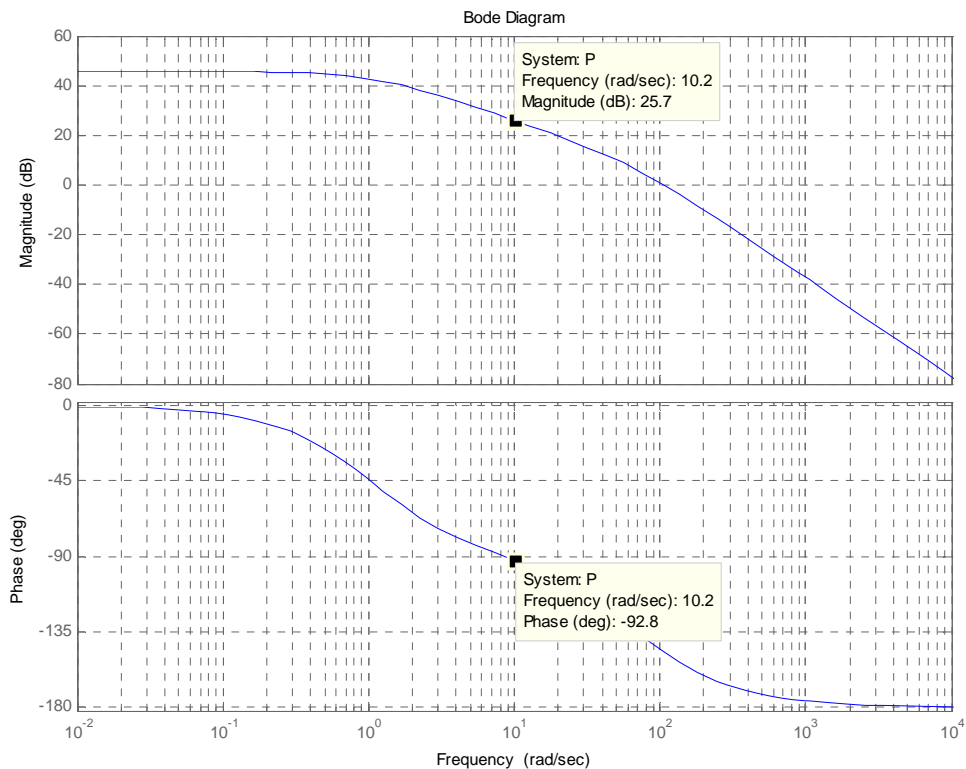

The compensator is designed by postulating -25.8db at high frequencies with a higher break frequency of  $10.1/10=1.01$  rad/sec. The phase lag asymptote predicts -5.8 db one decade earlier at

0.101 rad/sec, and approximately 0db one octave before that at  $0.101/2=0.0505$  rad/sec. Maintaining unity dc gain for the compensator we get:  $G_c(s) = 10 * \frac{0.05(s + 1.01)}{(s + 0.0505)}$

**b.**

```
>> syms s
>> s=tf('s');
>> P=1361/(s^2+69*s+70.85);
>> Gc=10*0.05*(s+1.01)/(s+0.0505);
>> T=P/(1+P);
>> Tc=Gc*P/(1+Gc*P);
>> step(T,Tc,0.7)
```

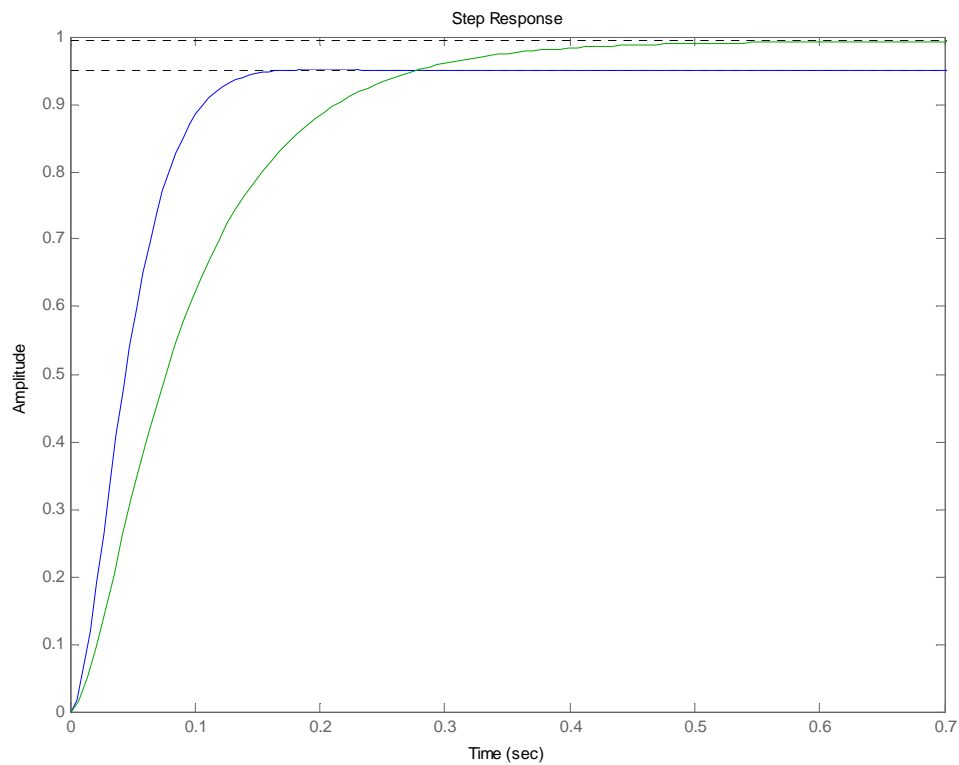



26.

a. For a phase margin of  $30^\circ$  the gain is  $K = 0.00135$  as shown in the following bode plot

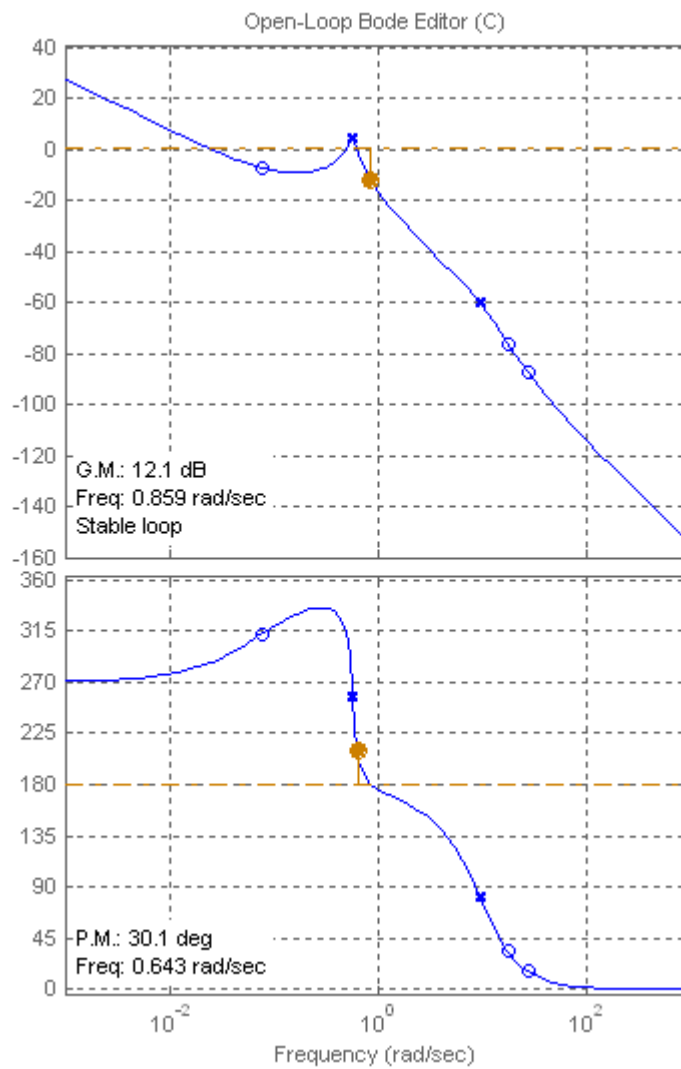

b. The gain margin is 12.1db

- c. From figure 10.48 a phase margin of  $30^\circ$  corresponds to a  $\xi = 0.3$  damping factor. This in turn corresponds to a %OS=37%. The bode plot above shows three crossovers of -7db. We use the largest one as the estimate for  $\omega_{\max} = 0.328 \frac{\text{rad}}{\text{sec}}$ ; from equation 10.55 we get  $T_s \approx 59 \text{ sec}$

d.

```
>>syms s
>>s=tf('s');
>>P=(-34.16*s^3-144.4*s^2+7047*s+557.2)/(s^5+13.18*s^4+95.93*s^3+14.61*s^2+31.94*s);
>> L=0.00135*P;
>> T=L/(1+L);
>> t=linspace(0,350,5000);
>> step(T,t)
```

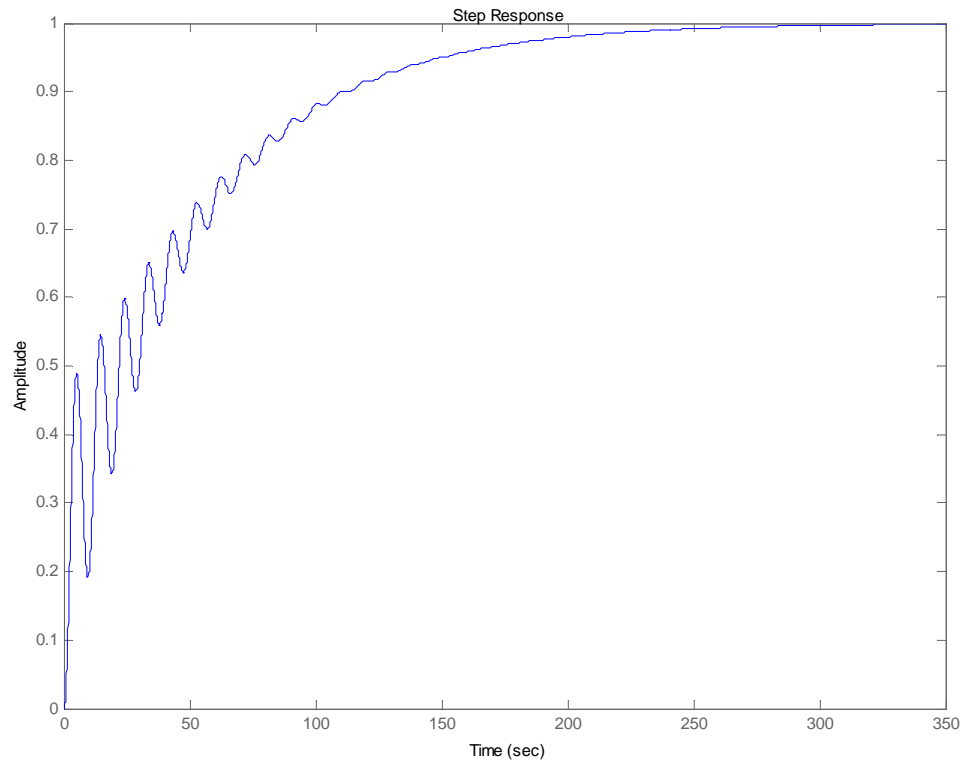

The estimate for the %OS is very inaccurate, the settling time estimate is reasonable.

e. The reason the estimate of %OS is very inaccurate is due to the multiple crossovers of the magnitude response. The hypothesis of a second order approximation is invalid.

27.

$G(s) = \frac{10}{s(s^2+2s+5)(s+3)}$ . Therefore,  $K_{VO} = \frac{2}{3}$ . We want  $K_{VN} = 30K_{VO} = 20$ . Increasing K by 30

times yields  $G(s) = \frac{300}{s(s^2+2s+5)(s+3)}$

Plotting the Bode diagrams,

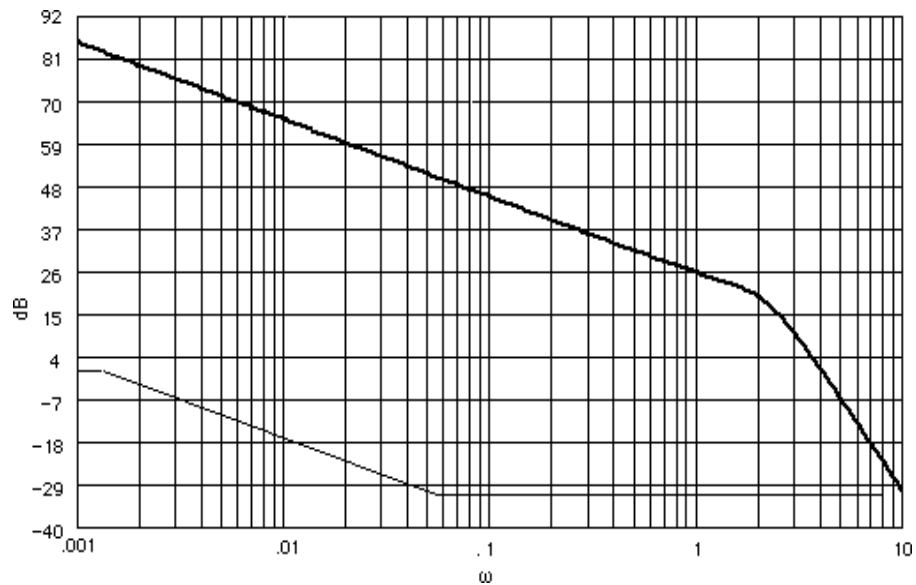

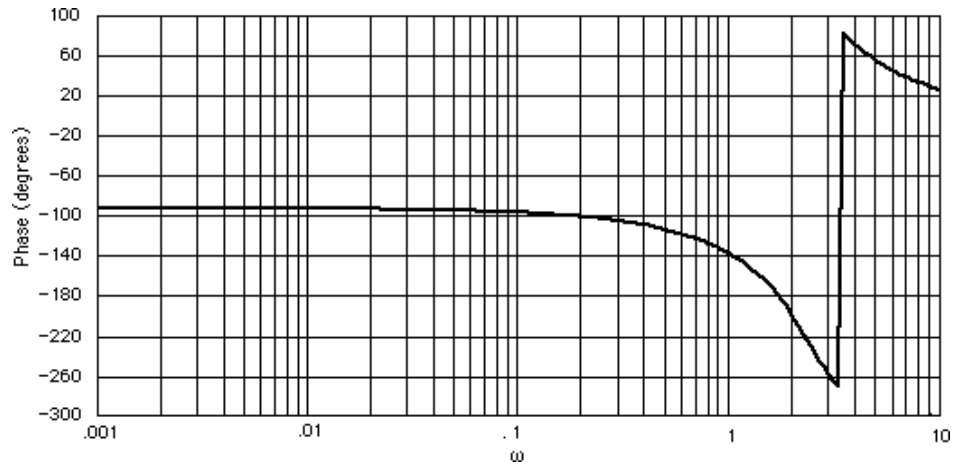

For 11% overshoot, the phase margin should be  $57.48^\circ$ . Adding a correction, we will use a  $65^\circ$  phase margin, or a phase angle of  $115^\circ$ , which occurs at  $\omega = 0.58$  rad/s. The magnitude curve is 30.93 dB. Thus the high-frequency asymptote of the lag compensator is -30.93 dB. Drawing the lag-compensator curve as shown on the magnitude curve, the break frequencies are found and the compensator's transfer function is evaluated as

$$G_c(s) = 25.86 \times 10^{-3} \frac{s+0.058}{s+0.0015}$$

28.

$G(s) = \frac{10K}{s(s+1)(s+5)}$ . For  $K_v = 5$ ,  $K = 2.5$ . Plot the Bode diagrams for this value of gain.

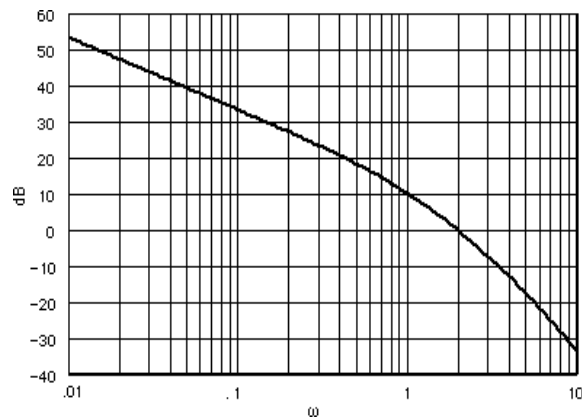

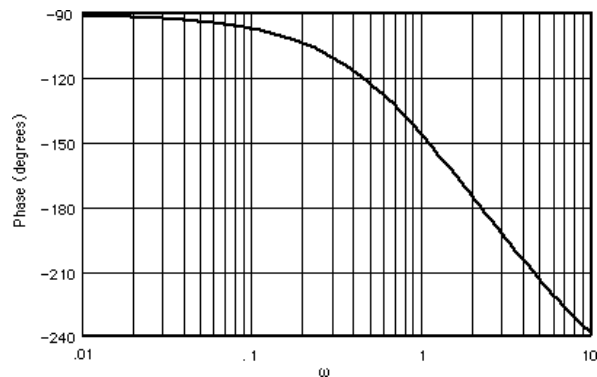

The uncompensated system has unity gain at  $\omega = 2.04$  rad/s. The phase is  $-176.08^\circ$  at this frequency yielding a phase margin of  $3.92^\circ$ . We want a  $60^\circ$  phase margin plus, after trial and error, a correction factor of  $20^\circ$ , or a total of  $80^\circ$ . Thus, the lead compensator must contribute  $80^\circ - 3.92^\circ = 76.08^\circ$ . Using Eqs. (11.11), and (11.12),

The value of beta is:	0.01490254
The $ G(j\omega_{max}) $ for the compensator is:	8.1916207
or in db:	18.2673967

The magnitude curve has a gain of  $-18.27$  dB at  $\omega = 5.27$  rad/s. Therefore, choose this frequency as the new phase margin frequency. Using Eqs. (11.9) and (11.6), the compensator transfer function has the following specifications:

T	1.55438723
zero	-0.6433403
pole	-43.169841
gain	67.1026497

The compensated forward path is

$$G(s) = \frac{25 \cdot 67.1(s+0.64)}{s(s+1)(s+5)(s+43.17)} = \frac{1677.5(s+0.64)}{s(s+1)(s+5)(s+43.17)}$$

29.

a. The %OS spec required a damping factor of  $\xi = \frac{-\ln(\%OS/100)}{\sqrt{\pi^2 + \ln^2(\%OS/100)}} = 0.5$ , which in

turn requires a phase margin of  $\Phi_M = \tan^{-1} \frac{2\xi}{\sqrt{-2\xi^2 + \sqrt{1+4\xi^4}}} = 52^\circ$ . The bandwidth

requirement is obtained from  $\omega_{BW} = \frac{4}{T_s \xi} \sqrt{1 - 2\xi^2 + \sqrt{4\xi^4 - 4\xi^2 + 2}} = 5088.1 \frac{\text{rad}}{\text{sec}}$ . To

obtain the compensator gain requirement to achieve this bandwidth obtain

$$G(j5088.1) = -\frac{3.3333 \times 10^4}{5088.1^2} = -0.0013. \text{ The compensator's gain can be obtained from } 0.0013K = \frac{1}{\sqrt{2}} \text{ or } K = 549.1891.$$

The required open loop crossover frequency is obtained by solving  $549.2 \frac{3.3333 \times 10^4}{\omega_c^2} = 1$ , giving  $\omega_c = 4280 \frac{\text{rad}}{\text{sec}}$ . This is the frequency at which the lead compensator should provide

maximum lead phase. So for the design of the compensator from Figure 11.8 let  $\beta = 0.1$  with  $\omega T \approx 3.5$  giving  $T = \frac{3.5}{\omega_c} = 8.1776 \times 10^{-4}$ . So the designed compensator is

$$G_c(s) = \frac{K}{\beta} \frac{s + \frac{1}{T}}{s + \frac{1}{\beta T}} = 549.2 \frac{10(s + 1222.9)}{(s + 12229.9)}. \text{ The gain of the compensator is now adjusted so}$$

that the maximum phase lead is provided at the crossover frequency giving  $G_c(s) = 173.7 \frac{10(s + 1222.9)}{(s + 12229.9)}$ . However a time domain simulation shows that although

the settling time spec is satisfied the resulting %OS=22%. The parameters of the phase lead compensator are slightly adjusted to provide more phase lead giving  $G_c(s) = 173.7 \frac{15(s + 1000)}{(s + 15000)}$

**b.**

```
>> syms s
>> s=tf('s');
>> P=3.3333e4/s^2;
>> G=173.67*15*(s+1000)/(s+15000);
>> L=G*P;
>> T=L/(1+L);
>> step(T,4e-3)
```

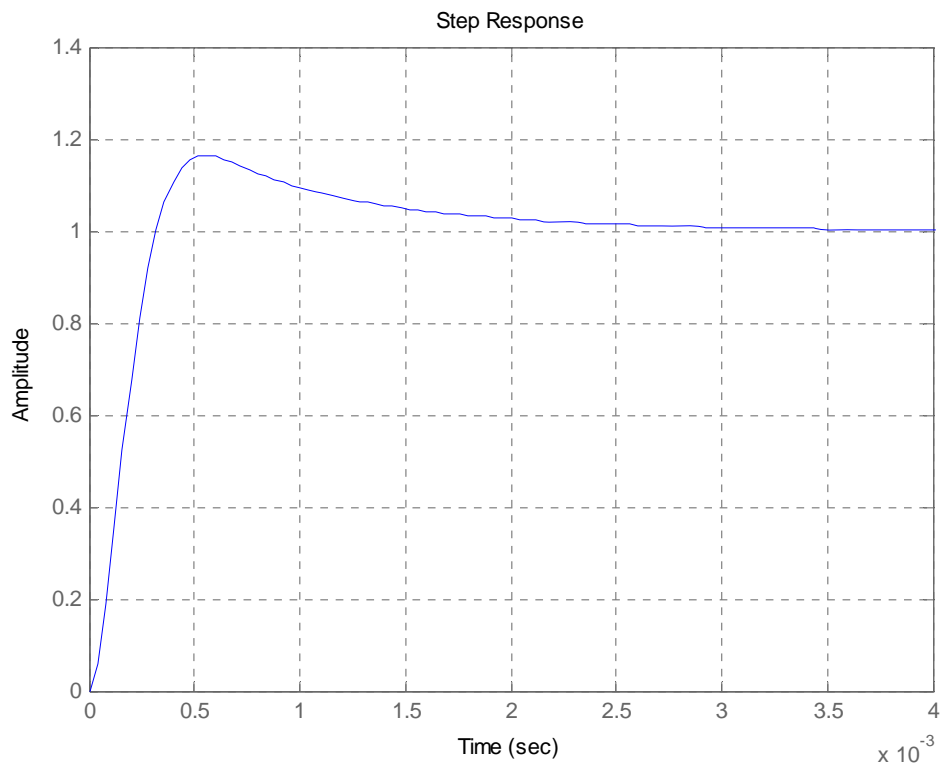

**30.**

a. The equivalent forward transfer function is  $G_e(s) = \frac{4.514e-06K}{s(s+0.04348)}$ .

$K_v = 200 = \frac{4.514e-06K}{0.04348}$  or  $K = 1926500$ . Using Eq. (4.39),  $\zeta = 0.456$ . Using Eq. (10.55),  $\omega_{BW} =$

1.16. Using Eq. (10.73) with 15° additional, the required phase margin,  $\phi_{req} = 63.15^\circ$ . Select a new phase-margin frequency,  $\omega_{pm} = 0.8 \omega_{BW} = 0.93$ . Plot the Bode plots for  $K = 1926500$ .

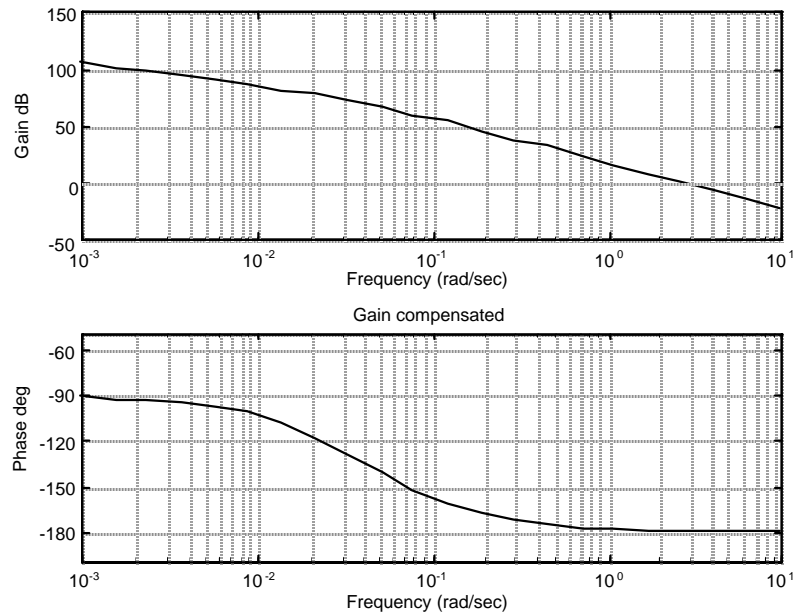

At  $\omega_{pm} = 0.93$ , the phase,  $\phi = -177.3^\circ$ . Hence, the phase required from the compensator,  $\phi_C = \phi_{req} - (180 + \phi) = 63.15 - (180 - 177.3) = 60.45^\circ$ . Using Eq. (11.11),  $\beta = 0.07$ .

Design lag:  $z_{clag} = \omega_{pm}/10 = 0.093$ ;  $p_{clag} = z_{clag} * \beta = 0.0065$ ;  $K_{clag} = \beta = 0.07$ . Thus,

$$G_{clag}(s) = 0.07 \frac{s+0.093}{s+0.0065} .$$

**Design lead compensator:**  $z_{clead} = \omega_{pm} * \sqrt{\beta} = 0.25$ ;  $p_{clead} = z_{clead}/\beta = 3.57$ ;  $K_{clead} = 1/\beta = 14.29$ . Thus,

$$G_{clead}(s) = 14.29 \frac{s+0.25}{s+3.57} .$$

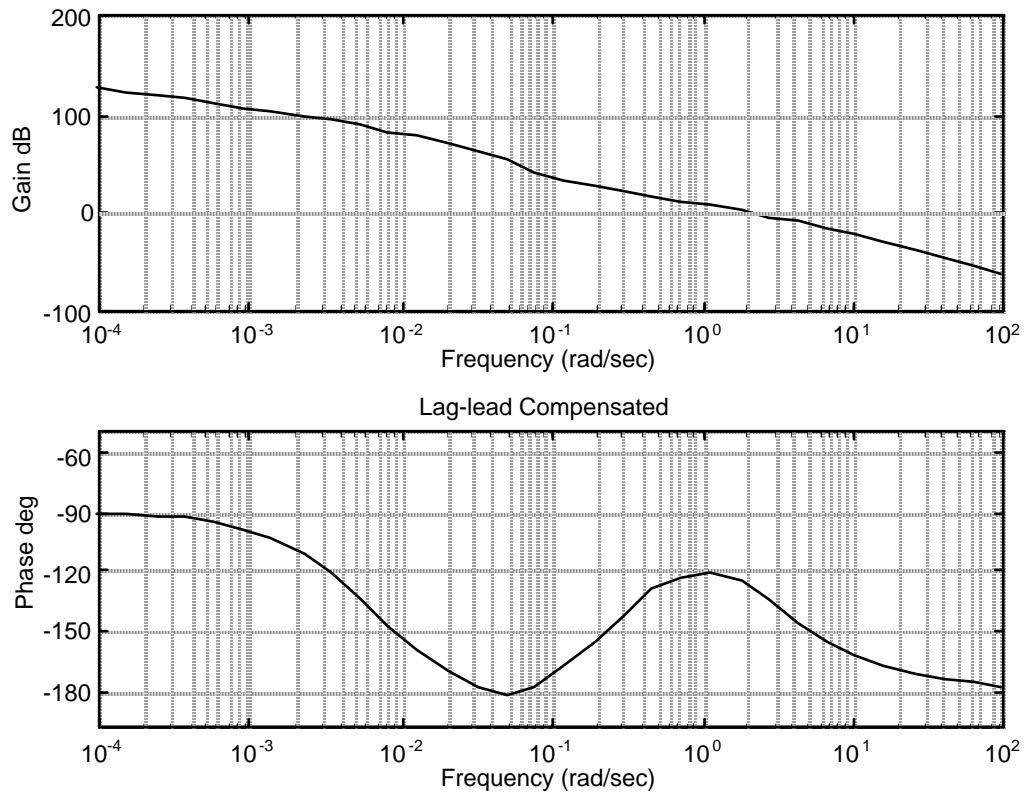

**The lag-lead compensated Bode plot:****b.****Program:**

```

K=1926500;
numg=4.514e-6;
deng=[1 0.04348 0];
G=tf(numg,deng);
numgclag=0.07*[1 0.093];
dengclag=[1 0.0065];
Gclag=tf(numgclag,dengclag);
numgclead=14.29*[1 0.25];
dengclead=[1 3.57];
Gclead=tf(numgclead,dengclead);
Ge=K*G*Gclag*Gclead;
T=feedback(Ge,1);
step(T)
title('Lag-lead Compensated')

```

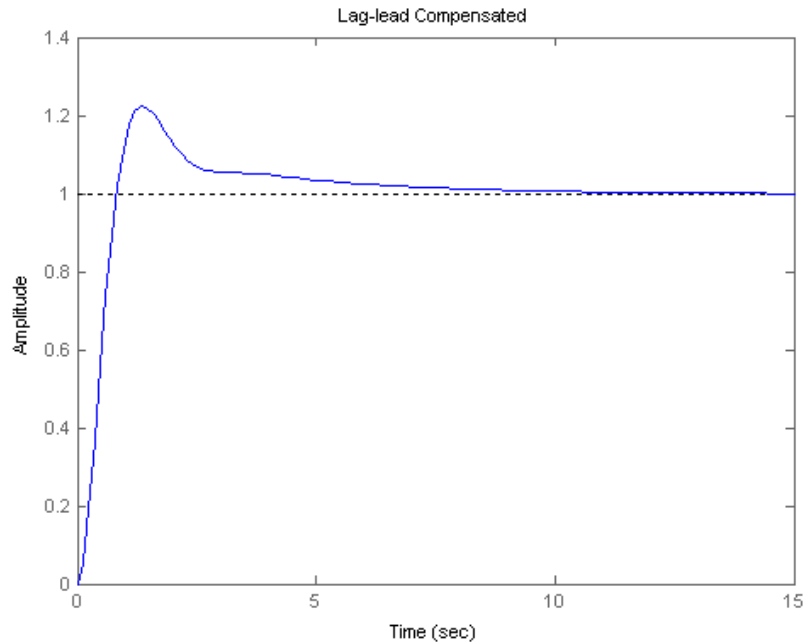
**Computer response:****31.**

We follow the step outlined in the chapter.

**a.**

1. We calculate the required  $\xi = \frac{-\ln(\%OS/100)}{\sqrt{\pi^2 + \ln^2(\%OS/100)}} \approx 0.6$ . The required bandwidth is

$$\omega_{BW} = \frac{4}{T_s \xi} \sqrt{1 - 2\xi^2 + \sqrt{4\xi^4 - 4\xi^2 + 2}} = 0.128 \frac{\text{rad}}{\text{sec}}$$

2. The uncompensated system is  $G(s) = \frac{5.8333 \times 10^{-4} K}{(s + 0.02)(s + 0.0833)(s + 0.25)}$  so

$$K_p = G(0) = 1.4K. \text{ The steady state requirement requires } \frac{1}{1 + 1.4K} = 0.05 \text{ or } K = 13.6$$

3. The bode plot for the uncompensated system is

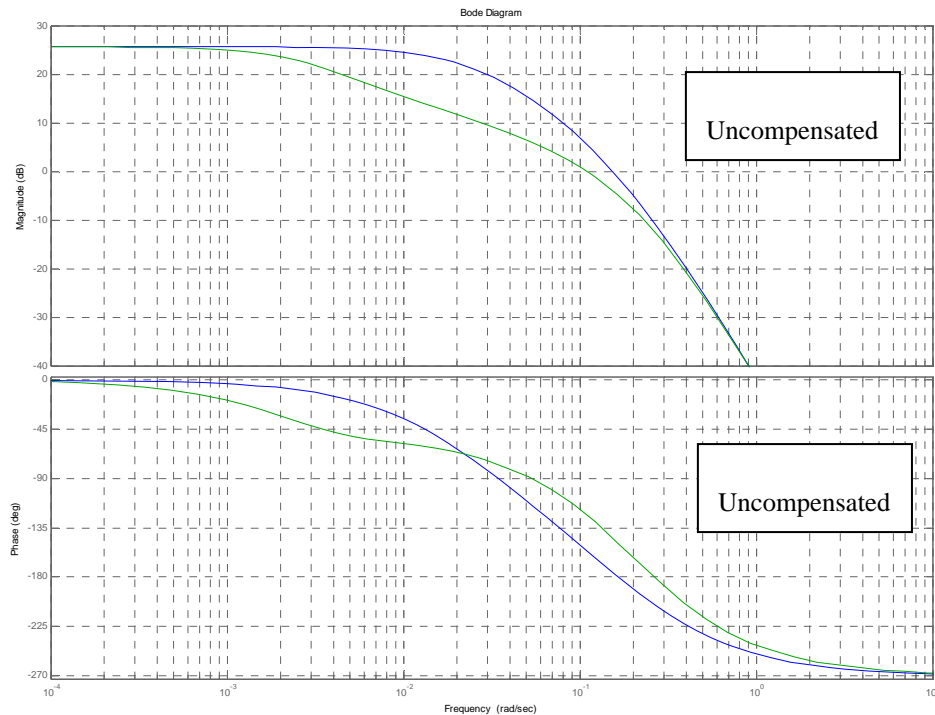

4. The required phase margin for the design is  $\Phi_M = \tan^{-1} \frac{2\xi}{\sqrt{-2\xi^2 + \sqrt{1+4\xi^4}}} = 59.2^\circ$

5. We arbitrarily select  $\omega = 0.1 \frac{\text{rad}}{\text{sec}}$

6. It can be seen from the uncompensated bode plot that at  $\omega = 0.1 \frac{\text{rad}}{\text{sec}}$  the phase margin is  $29^\circ$ .

The requirement in the phase lead network is going to be  $59.2^\circ - 29^\circ + 5^\circ$  (for the lag compensator contribution)  $= 35.2^\circ$

7. The lag compensator design is done by choosing the higher break frequency as  $\frac{0.1}{10} = 0.01 \frac{\text{rad}}{\text{sec}}$ . From the lead compensator graphs, figure 11.8 in the text let  $\beta = 0.25$  or

$$\gamma = \frac{1}{\beta} = 4. \text{ So the lag compensator is given by } G_{c\_lag} = \frac{1}{\gamma} \frac{(s + \frac{1}{T_2})}{(s + \frac{1}{\gamma T_2})} = \frac{1}{4} \frac{(s + 0.01)}{(s + 0.0025)}$$

8. For the lead compensator design  $\omega_{\max} = 0.1$  and  $\beta = 0.25$ .  $\frac{1}{T_1} = \omega_{\max} \sqrt{\beta} = 0.05$  and

$$\frac{1}{\beta T_1} = 0.2 \text{ Resulting in } G_{c\_lead} = \gamma \frac{(s + \frac{1}{T_1})}{(s + \frac{\gamma}{T_1})} = 4 \frac{(s + 0.05)}{(s + 0.2)}$$

9. The resulting lag-lead compensator is  $G_c(s) = 13.6 \frac{(s + 0.01)(s + 0.05)}{(s + 0.0025)(s + 0.2)}$ . The resulting compensated bode plot is shown above.
- b. The step response simulation is

```
>> syms s
>> s=tf('s');
>> G=13.6*5.8333e-4/(s+0.02)/(s+0.25)/(s+0.0833);
>> Gc = (s+0.01)*(s+0.05)/(s+0.0025)/(s+0.2);
>> L=G*Gc;
>> T=L/(1+L);
>> step(T)
```

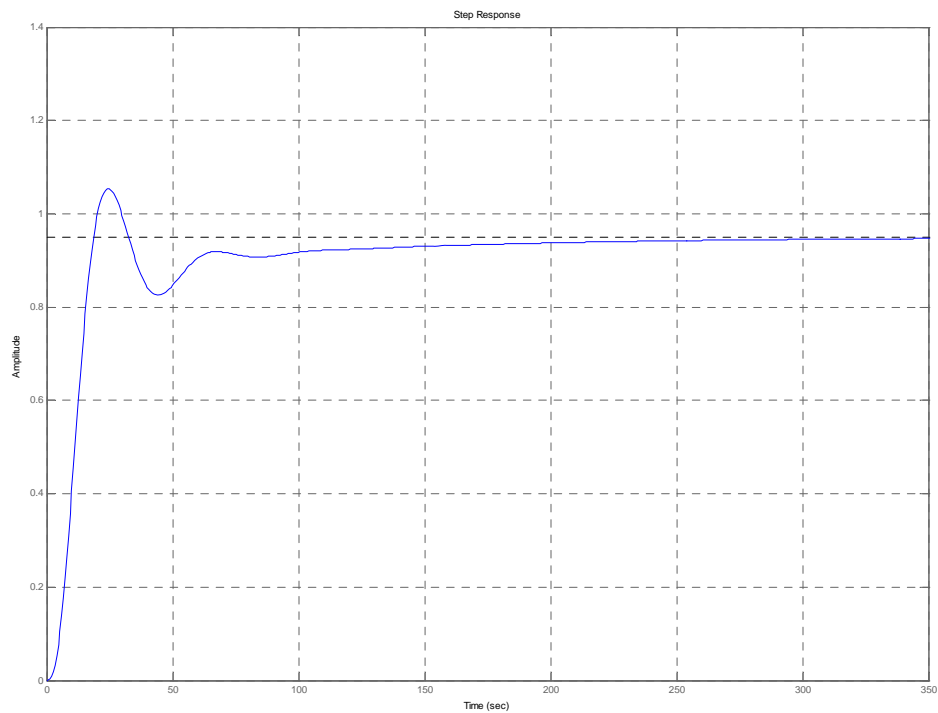

The system exhibits a “long tail” response because compensation adds a pole-zero pair very close to the origin. However it can be seen that after 60sec the response is very close to steady state.

32.

- a. Using equation (4.39),  $\alpha=0.7$ . Then from equation (10.52)  $M_p=1=0\text{db}$ . For zero steady state error we add an integrator, and then we raise the system's gain.

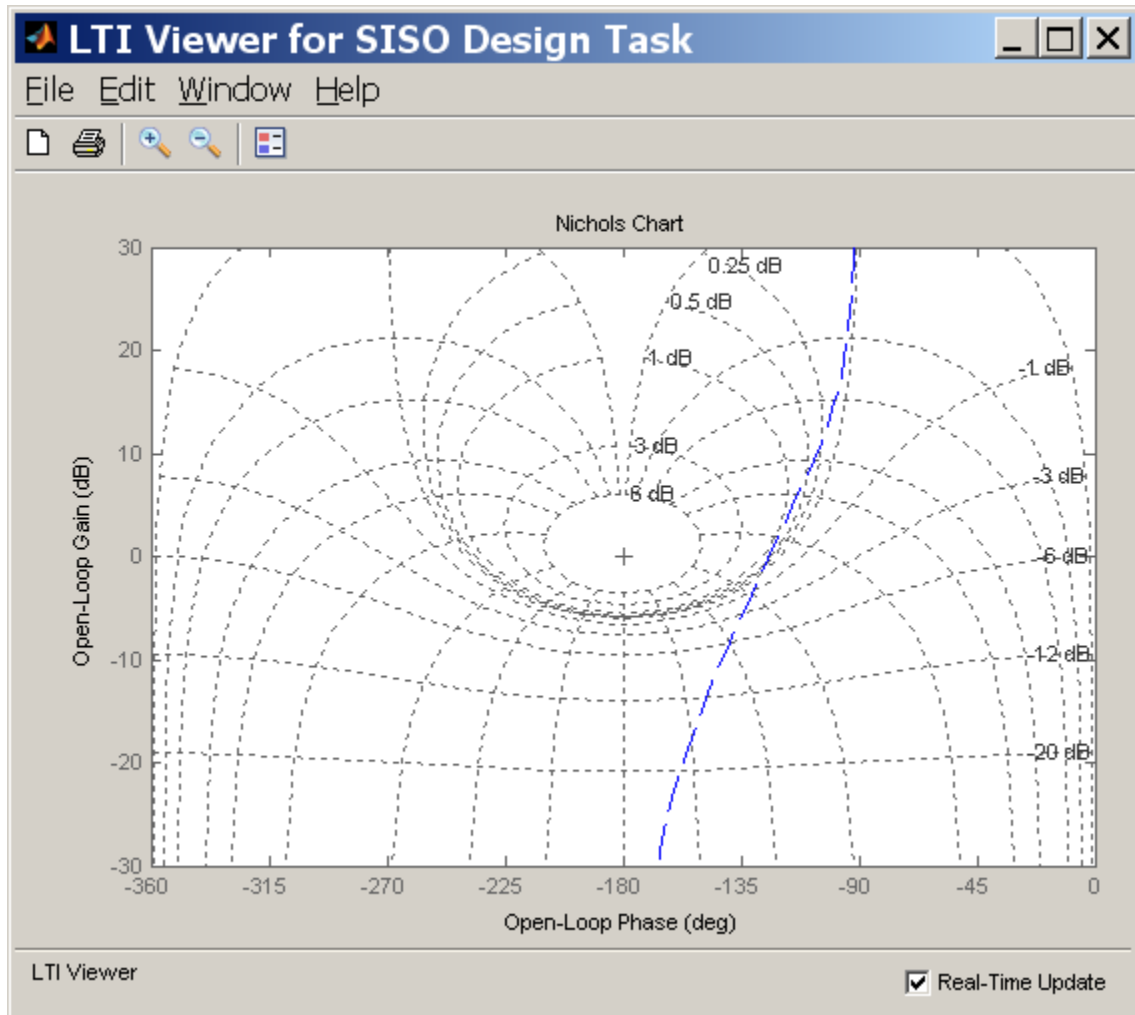

Then we design an appropriate lead compensator. So far,  $G_{lead} = \frac{3.038(s+4.6)}{s(s+13.7)}$  as

shown in the figure with a slight violation of the 1db requirement.

The resulting  $K_v=8.306$  so a factor of 2.4 is needed to reach the required 20. The lag compensator is designed by arbitrarily adding a pole zero pair at 0.1 and 0.24

respectively, giving  $G_{lag} = \frac{s+0.24}{s+0.1}$ . The total compensation is

$$G_c = \frac{3.038(s+0.24)(s+4.6)}{s(s+0.1)(s+13.7)}$$

- b. For this design, we start by adding an integrator to the compensator. The resulting  $K_v=8.14$  so a  $K=2.46$  is needed to obtain  $K_v=20$ . Then enough lead is provided to satisfy

the  $M_p < 1\text{db}$  requirement. The resulting  $G = \frac{35(s + 2.18)}{s(s + 31)}$ . The resulting

$\omega_B = 32 \text{ rad/sec}$  as shown in the next figure.

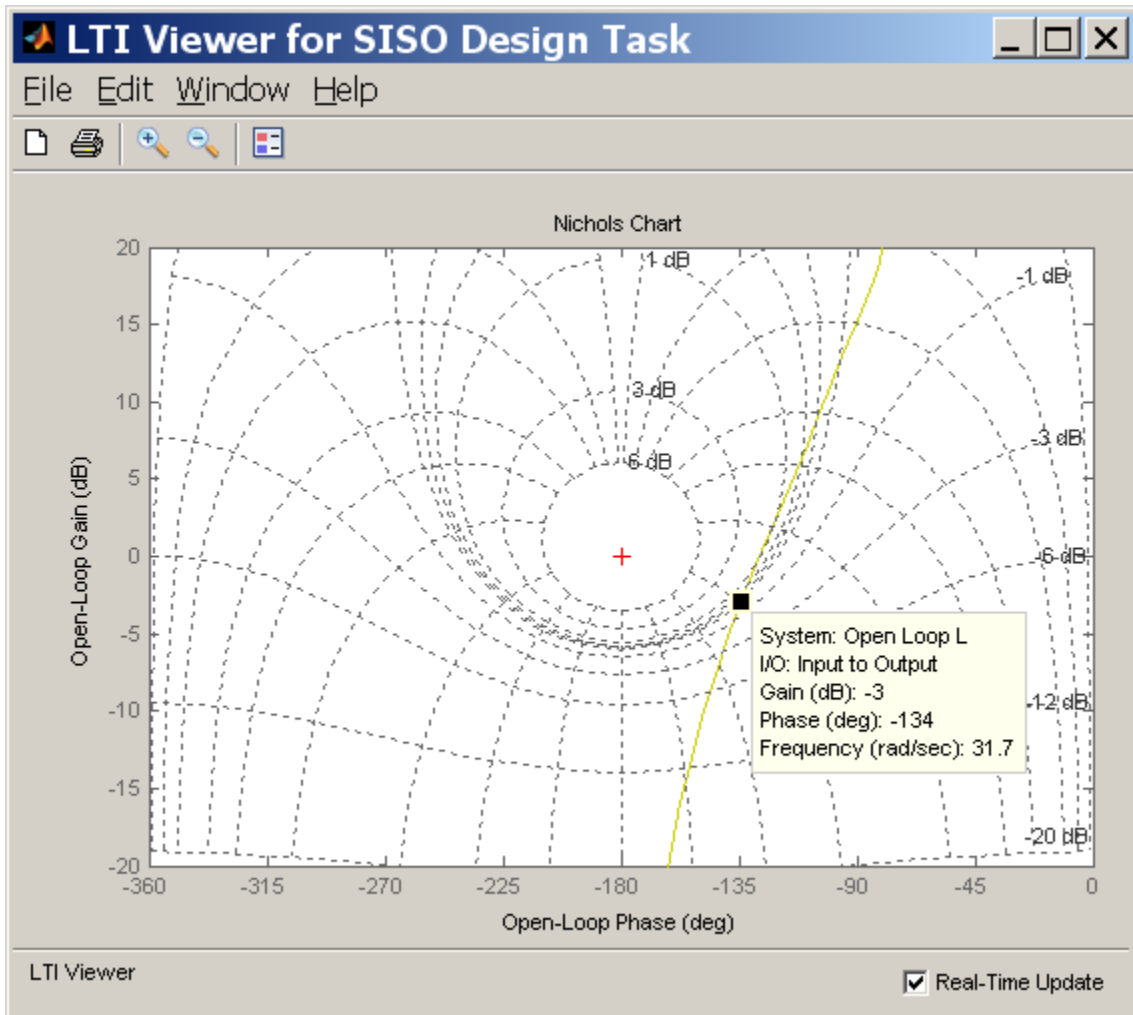

c. The following figure shows the step response of both designs. The faster design corresponds to part b with the larger bandwidth.

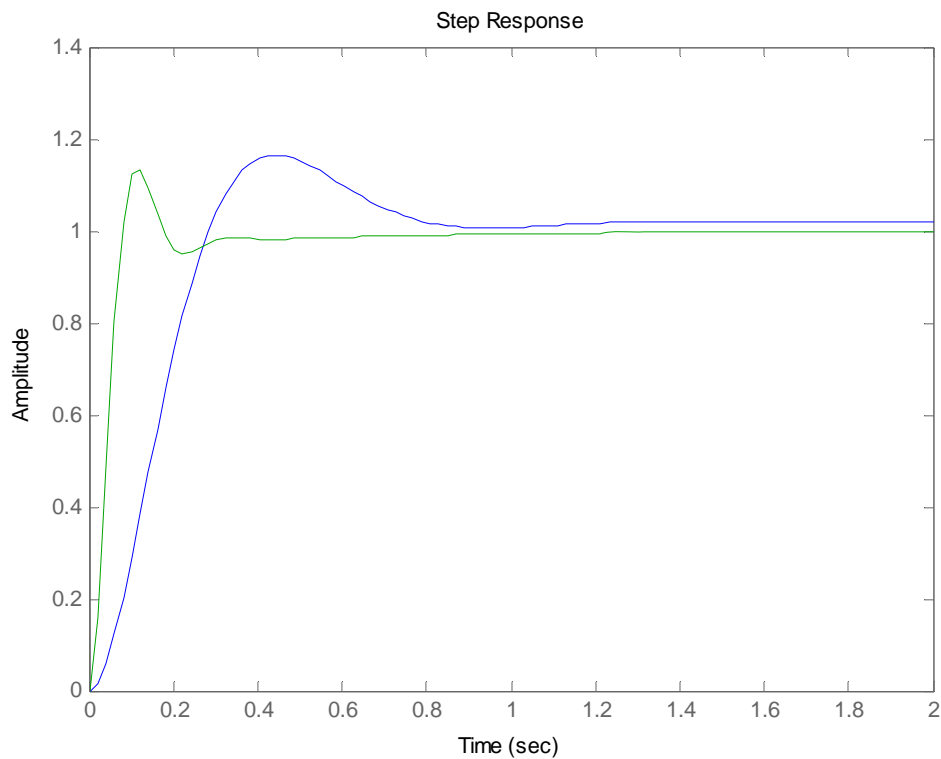

33.

From Chapter 8,

$$G_e(s) = \frac{0.6488K (s+53.85)}{(s^2 + 8.119s + 376.3) (s^2 + 15.47s + 9283)}$$

Cascading the notch filter,

$$G_{et}(s) = \frac{0.6488K (s+53.85)(s^2 + 16s + 9200)}{(s^2 + 8.119s + 376.3) (s^2 + 15.47s + 9283)(s+60)^2}$$

Since  $e_{step}(\infty) = \frac{1}{1 + K_p}$ ,  $K_p = 9$  yields 10% error. Thus,  $K_p = \frac{K_e * 53.85 * 9200}{376.3 * 9283 * 60^2} = 9$ . Thus,

$K_e = 0.6488K = 228452$ . Let us use  $K_e = 30,000$  in designing the lead portion and we'll make up the rest with the lag. Plotting the Bode plot for  $K_e = 30,000$ ,

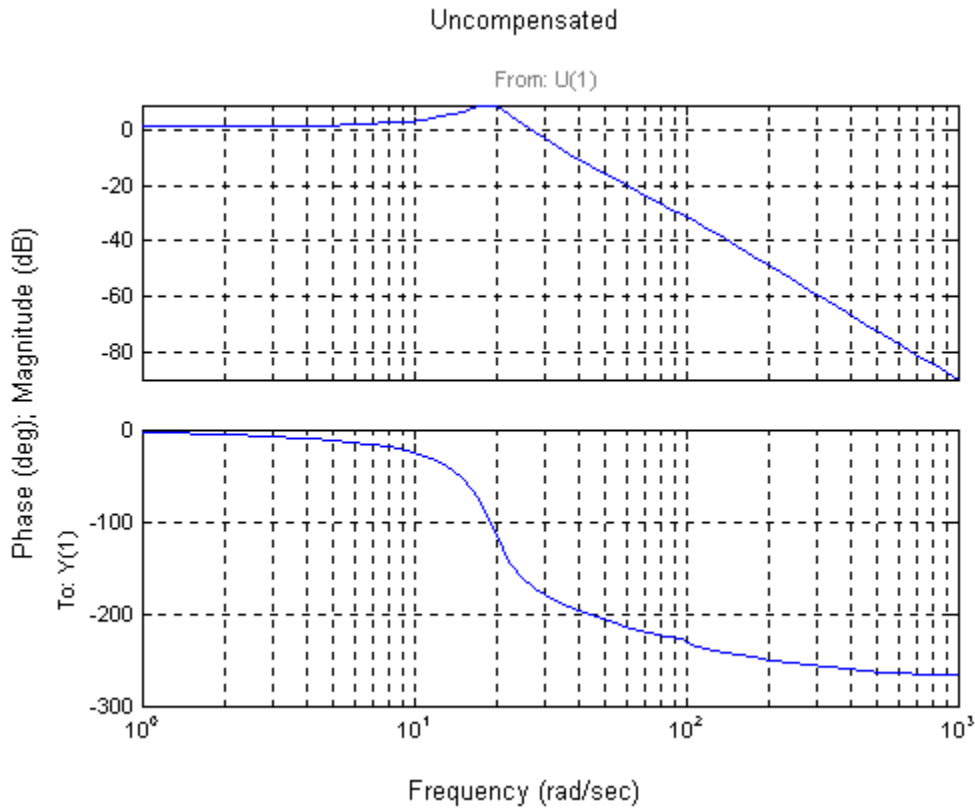

**Design lead:** The uncompensated phase margin =  $10.29^\circ$ . Assume a required phase margin of  $45^\circ$ . The required phase margin, assuming a  $30^\circ$  correction is  $75^\circ$ . The phase contribution required from the compensator is  $75^\circ - 10.29^\circ = 64.71^\circ$ . Using the inverse of Eq. (11.11), the compensator's  $\beta = 0.05033$ . Using Eq. (11.12),  $|G_c(j\omega_{\max})| = \frac{1}{\sqrt{\beta}} = 4.457 = 12.98 \text{ dB}$ . The new phase margin frequency is where the uncompensated system has a magnitude of  $-12.98 \text{ dB}$ , or  $\omega_{\max} = 44.65 \text{ rad/s}$ .

Using Eqs. (11.6) and (11.9), the compensator is  $G_{lead}(s) = \frac{19.87(s + 10.02)}{(s + 199)}$ . The plant is

$$G(s) = \frac{228452(s + 53.85)(s^2 + 16s + 9200)}{(s + 60)^2(s^2 + 8.119s + 376.3)(s^2 + 15.47s + 9283)}$$

Draw the lead-compensated

Boode plot.



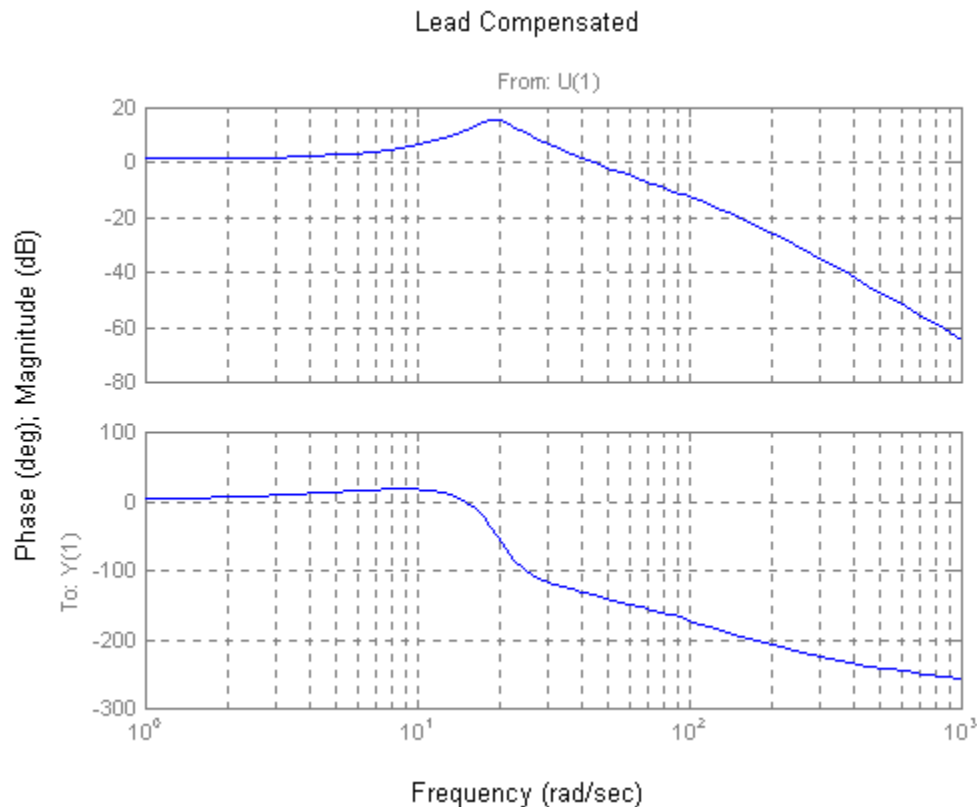

**Design lag:** The phase-margin frequency occurs where the phase is  $-135^\circ$ , or at the required  $45^\circ$  phase margin. From the lead-compensated Bode plots, this phase margin occurs at 43.64 rad/s. Let the upper break of the lag compensator be one decade lower, or 4.364. Since the magnitude is 17.97 dB at the new phase-margin frequency, set the high-frequency asymptote of the lag compensator at  $-17.97$  dB. Draw a  $-20$  dB/dec slope starting at 0.4364 rad/s and  $-17.96$  dB and moving toward 0 dB. At 0 dB locate the lag compensator's low-frequency break, or 0.551. Thus,

$$G_{lag}(s) = \frac{0.551 (s + 4.364)}{4.364 (s + 0.551)} = 0.126 \frac{(s + 4.364)}{(s + 0.551)}$$

**Check bandwidth:** Draw the lag-lead compensated Bode diagram for  $G(s)G_{lag}(s)G_{lead}(s)$ .

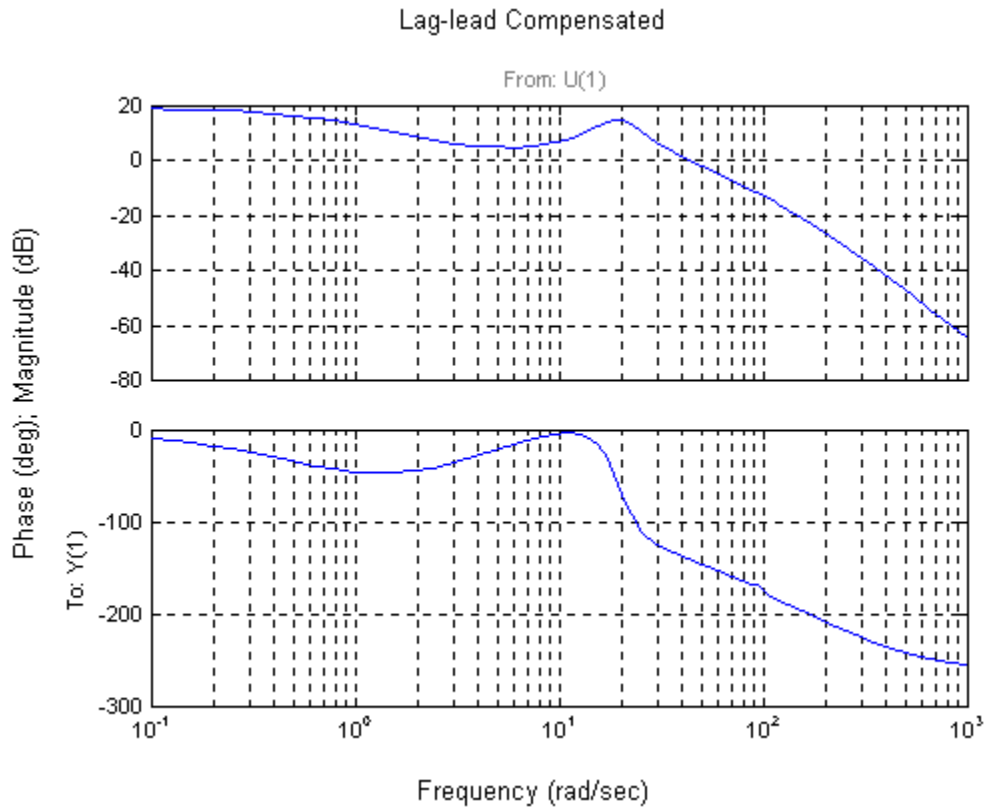

From the open-loop plot, the magnitude is at  $-7$  dB at  $70$  rad/s. Hence, the bandwidth is sufficient. Also, the lag-lead compensated Bode plot shows a phase margin of  $40^\circ$ . The transfer function,  $G(s) = G(s)G_{\text{lag}}(s)G_{\text{lead}}(s)$  shows  $K_p = 9$ , or an error of  $0.1$ . Thus all requirements have been met.

34.

a. For an overdamped system  $T_s = \frac{4}{\omega_{BW}}$ . So for this system  $\omega_{BW} = 0.04 \frac{\text{rad}}{\text{sec}}$

b. The bode plot is:

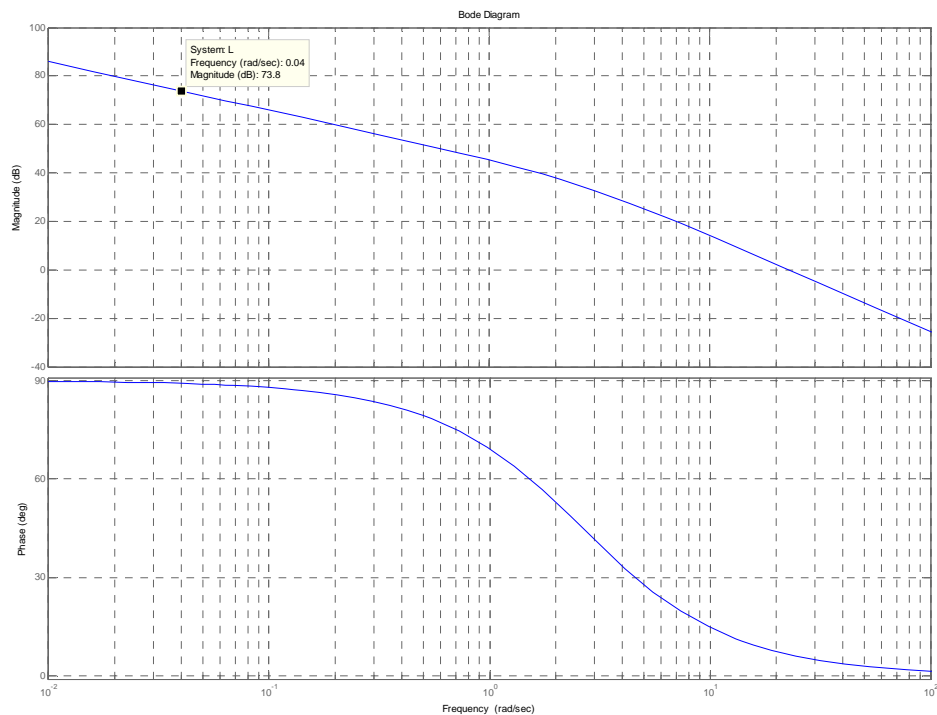

At  $-90^\circ$  of open loop phase lag the crossover frequency of the open loop transmission equals the bandwidth of the closed loop system, so it can be seen that we have to drop the magnitude 73.8db. So  $K = 2e - 4$ . Note that in the low range of frequencies the phase of the loop transmission is approximately  $-90^\circ$ , lowering the gain will maintain closed loop stability.

**c.**

```
>> syms s
>> s=tf('s');
>> G=-2e-4*(s^2+0.04*s+0.0048)/(s+0.02)/s;
>> L=G*P;
>> T=L/(1+L);
>> step(T)
```

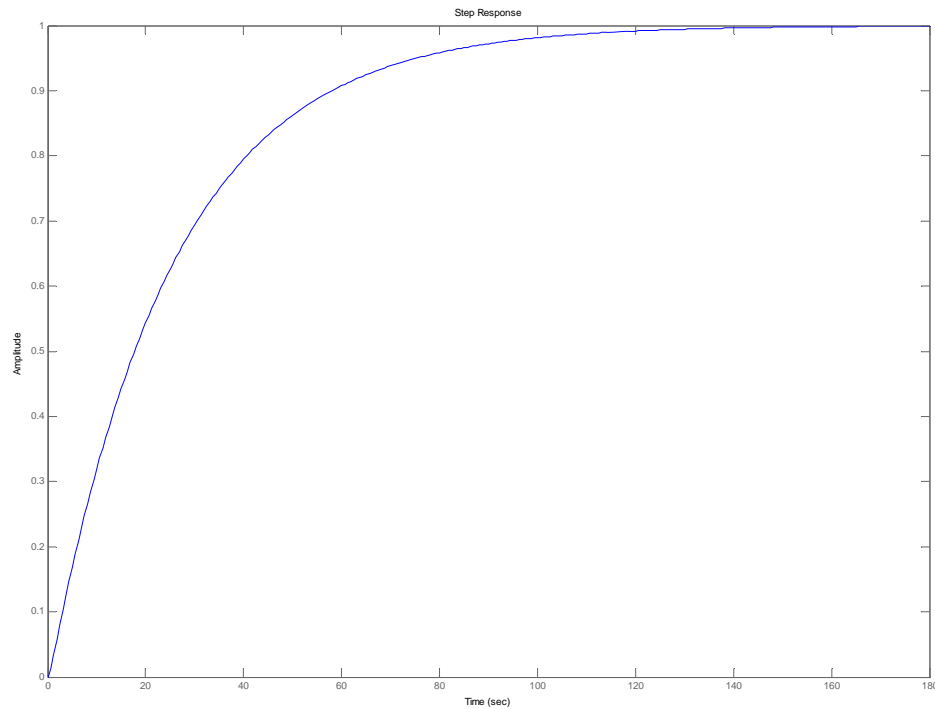

No further gain adjustments are necessary.

35.

a. For a zero steady-state error for step inputs and a steady-state error for ramp inputs  $\leq 2\%$ , the required value of  $K$  may be found from:

$$e_{ramp}(\infty) = \frac{1}{K_v} \leq 0.02, \text{ where } K_v = \lim_{s \rightarrow 0} sG(s) = \lim_{s \rightarrow 0} \frac{K(s+0.6)}{(s+0.5858)} \geq 50.$$

$$\text{Hence: } \frac{0.6 \times K}{0.5858} \geq 50 \Rightarrow K \geq 48.82$$

The following MATLAB file was used to plot the Bode magnitude and phase plots for that system and to obtain the response of the system,  $c(t)$ , to a step input,  $r(t) = 4 u(t)$ .

```
numg = [1 0.6];
```

```
deng = poly([0 -0.5858]);
```

```
G = 48.82*tf(numg, deng);
```

```

bode(G);

grid

pause

T = feedback(G,1); %T is the closed-loop TF of the PI-controlled system

T = minreal(T);

step(4*T);

axis

grid

xlabel('Time')

ylabel('Speed Sensor Output, c(t) in volts')

title('PI-controlled Systems Response to a 4 volt Input Step')

```

The Bode magnitude and phase plots obtained are shown below with the minimum stability margins displayed on the phase plot.

For a  $\%OS \leq 4.32\%$ , the damping ratio is

$$\zeta = \frac{-\ln(\%OS/100)}{\sqrt{\pi^2 + \ln^2(\%OS/100)}} = \frac{-\ln(4.32/100)}{\sqrt{\pi^2 + \ln^2(4.32/100)}} = 0.707. \text{ Using Eq. (10.73) we}$$

find the phase margin needed to meet the damping ratio requirement:

$$\Phi_M = \tan^{-1} \frac{2\zeta}{\sqrt{-2\zeta^2 + \sqrt{1 + 4\zeta^4}}} = 65.52^\circ$$

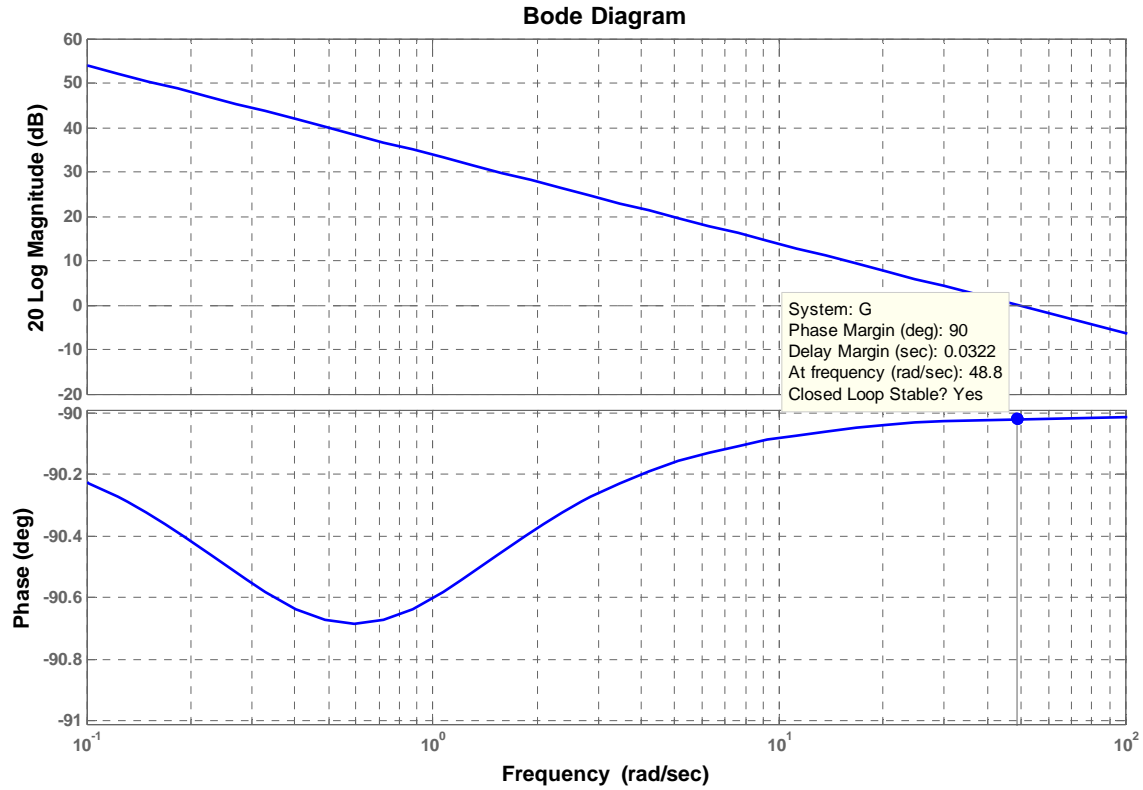

The phase margin found from the Bode plot obtained in step (1) is greater than the required value.

Therefore, the response of the system,  $c(t)$ , to a step input,  $r(t) = 4 u(t)$ , has been plotted and is shown below. The settling time,  $T_s$ , and the final value of the output are noted.

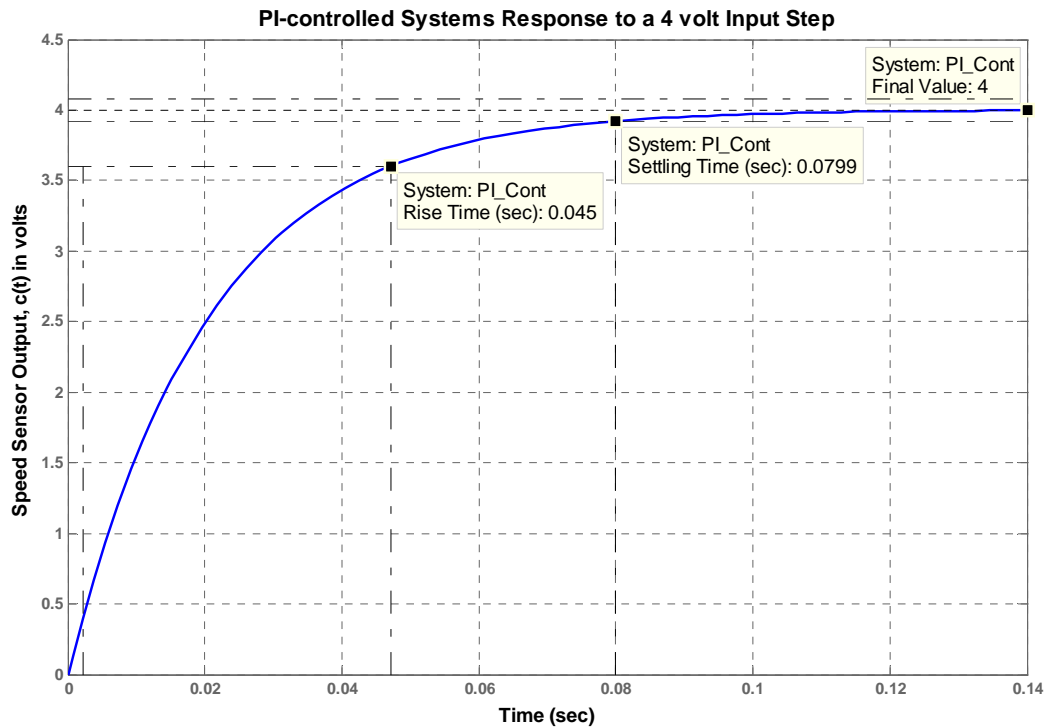

As could be seen from the graph and the analysis presented above all requirements are met.

Therefore, the design has been completed.

- b. 1) When the PI-controller zero,  $Z_i$ , moves to  $-0.01304$ :

$$K_v = \lim_{s \rightarrow 0} sG(s) = \lim_{s \rightarrow 0} \frac{K(s+0.6)(s+0.01304)}{(s+0.0163)(s+0.5858)} \geq 50 \Rightarrow K \geq 61.02.$$

The phase margin found from the Bode plot obtained is still greater than the required value.

Therefore,  $c(t)$  was plotted and is shown below with the settling time,  $T_s$ , and the final value of the output noted on the graph. As could be seen from the graph, the settling and rise times are less by  $\sim 20\%$  than the respective values obtained for  $Z_i$  at  $-0.0163$ .

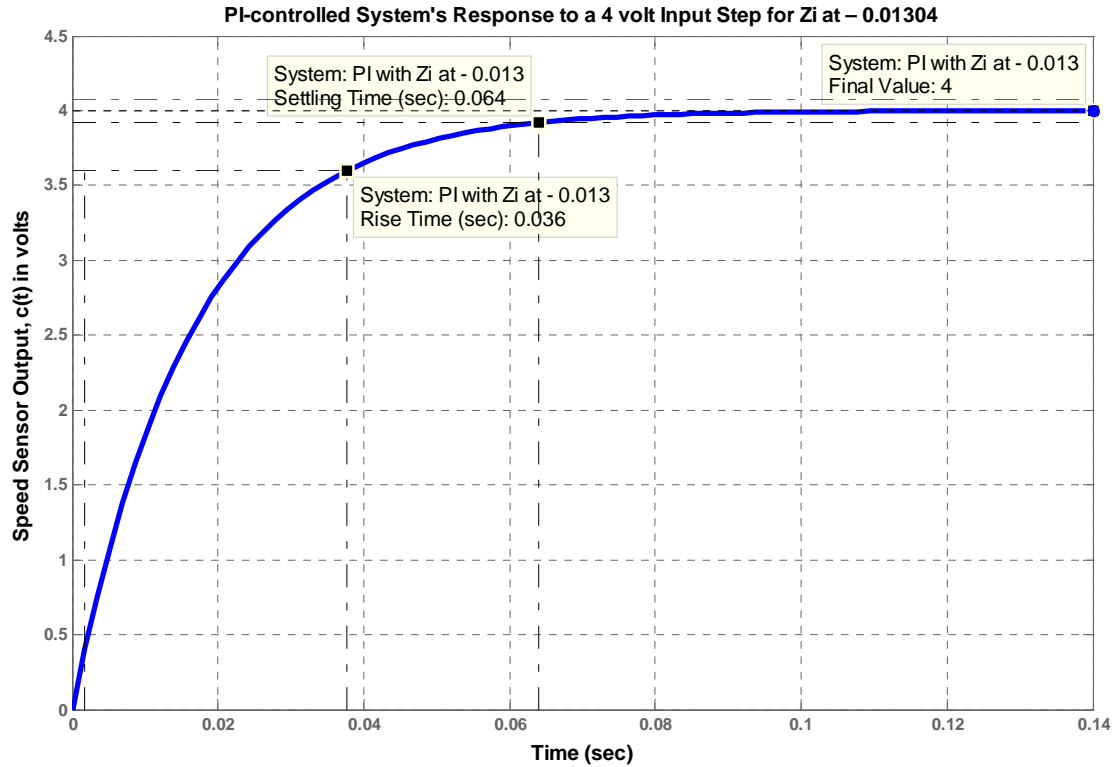

2) When the PI-controller zero,  $Z_i$ , moves to  $-0.01956$ :

$$K_v = \lim_{s \rightarrow 0} sG(s) = \lim_{s \rightarrow 0} \frac{K(s+0.6)(s+0.01956)}{(s+0.0163)(s+0.5858)} \geq 50 \Rightarrow K \geq 40.68.$$

The phase margin found from the Bode plot obtained is still greater than the required value.

Therefore,  $c(t)$  was plotted and is shown below with the settling time,  $T_s$ , and the final value of the output noted on the graph. In this case, however, the settling and rise times are higher by  $\sim 20\%$  than the respective values obtained for  $Z_i$  at  $-0.0163$ . Nevertheless, all requirements are still met.



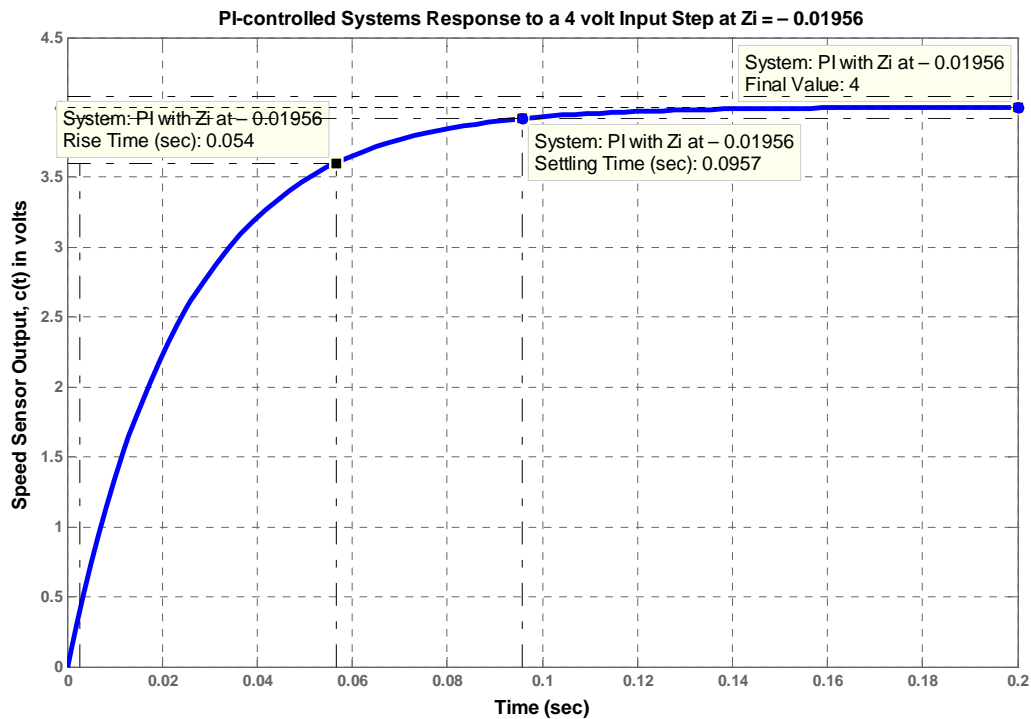

The responses obtained in all cases here are closer to the response of a first-order system rather than a second order system. Note that when  $Z_i$  is at  $-0.01956$ , for example, two of the closed-loop poles (at  $-0.6002$  and  $-0.01956$ ) are very close, respectively, to the closed-loop zeros located at  $-0.5999$  and  $-0.0196$ . Therefore, the system behaves as if it has only one closed-loop pole, which is at  $-40.66$ . Since the PI-controller designed meets all requirements (even when pole-zero cancellation is not achieved and the controller's zero changes by  $\pm 20\%$ ), there no need to add a derivative mode.

# T W E L V E

## Design via State Space

### SOLUTION TO CASE STUDY CHALLENGE

#### Antenna Control: Design of Controller and Observer

a. We first draw the signal-flow diagram of the plant using the physical variables of the system as state variables.

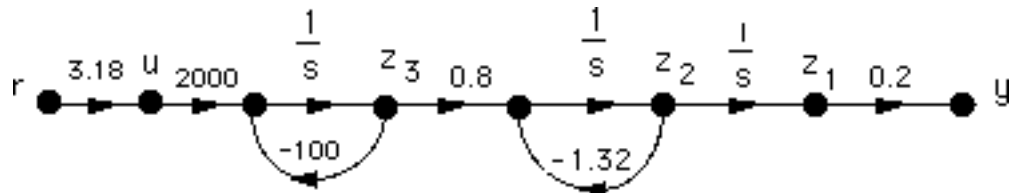

Writing the state equations for the physical variables shown in the signal-flow diagram, we obtain

$$\dot{\mathbf{z}} = \begin{bmatrix} 0 & 1 & 0 \\ 0 & -1.32 & 0.8 \\ 0 & 0 & -100 \end{bmatrix} \mathbf{z} + \begin{bmatrix} 0 \\ 0 \\ 2000 \end{bmatrix} u ; y = [0.2 \quad 0 \quad 0] \mathbf{z}$$

The characteristic polynomial for this system is  $s^3 + 101.32s^2 + 132s + 0$ . Hence, the **A** and **B** matrices of the phase-variable form are

<b>Ax</b>	<b>Bx</b>
0            1            0	0
0            0            1	0
0            -132        -101.32	1

Writing the controllability matrices and their determinants for both systems yields

<b>CMz</b>	Controllability Matrix of z		<b>CMx</b>	Controllability Matrix of x	
0	0	1600	0	0	1
0	1600	-162112	0	1	-101.32
2000	-200000	20000000	1	-101.32	10133.7424
<b>Det(CMz)</b>	-5.12E+09		<b>Det(CMx)</b>	-1	

where the system is controllable. Using Eq. (12.39), we find the transformation matrix and its inverse to be

<b>P</b>	Transformation Matrix z=Px		<b>PINV</b>		
1600	0	0	0.000625	0	0
0	1600	0	0	0.000625	0
0	2640	2000	0	-0.000825	0.0005

The characteristic polynomial of the phase-variable system with state feedback is

$$s^3 + (k_3 + 101.32)s^2 + (k_2 + 132)s + (k_1 + 0)$$

For 15% overshoot,  $T_s = 2$  seconds, and a third pole 10 times further from the imaginary axis than the dominant poles, the characteristic polynomial is

$$(s + 20)(s^2 + 4s + 14.969) = s^3 + 24s^2 + 94.969s + 299.38$$

Equating coefficients, the controller for the phase-variable system is

<b>Kx</b>	Controller for x	
299.38	-37.031	-77.32

Using Eq. (12.42), the controller for the original system is

<b>Kz</b>	Controller for z	
0.1871125	0.04064463	-0.03866

**b.** Using  $K_z$ , gain from  $\theta_m = -0.1871125$  (including gear train, pot, and operational amplifier); gain from tachometer =  $-0.04064463$ ; and gain from power amplifier output =  $0.03866$ .

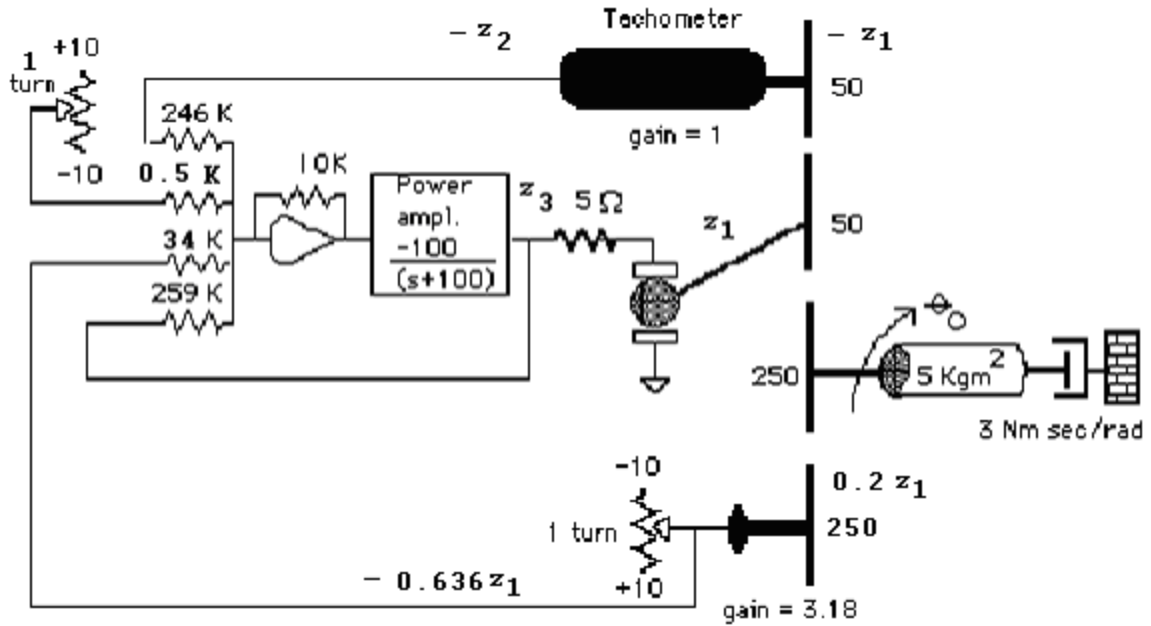

c. Using the original system from part (a) and its characteristic polynomial, we find the observer canonical form which has the following **A** and **C** matrices:

$$\begin{array}{r}
 \mathbf{Ax} \\
 -101.32 \quad 1 \quad 0 \\
 -132 \quad 0 \quad 1 \\
 0 \quad 0 \quad 0 \\
 \mathbf{Cx} \\
 1 \quad 0 \quad 0
 \end{array}$$

Writing the observability matrices and their determinants for both systems yields

<b>OMz</b>	Observability Matrix of z		<b>OMx</b>	Observability Matrix of x	
0.2	0	0	1	0	0
0	0.2	0	-101.32	1	0
0	-0.264	0.16	10133.7424	-101.32	1
<b>Det(OMz)</b>	0.0064		<b>Det(OMx)</b>	1	

where the system is observable. Using Eq. (12.89), we find the transformation matrix and its inverse to be

<b>P</b>	Transformation Matrix z=Px		<b>PINV</b>		
5	0	0	0.20	0.00	0.00
-506.6	5	0	20.26	0.20	0.00
62500	-625	6.25	26.40	20.00	0.16

The characteristic polynomial of the dual phase-variable system with state feedback is

$$s^3 + (I_1 + 101.32)s^2 + (I_2 + 132)s + (I_3 + 0)$$

For 10% overshoot,  $\omega_n = 10\sqrt{14.969} = 38.69$  rad/s, and a third pole 10 times further from the imaginary axis than the dominant observer poles, the characteristic polynomial is

$$(s + 228.72)(s^2 + 45.743s + 1496.916) = s^3 + 274.46s^2 + 11959s + 3.4237 \times 10^5$$

Equating coefficients, the observer for the observer canonical system is

<b>Lx</b>	Observer for x
173.14	
11827	
342370	

Using Eq. (12.92), the observer for the original system is

<b>Lz</b>	Observer for z
865.7	
-28577.724	
5569187.5	

d.

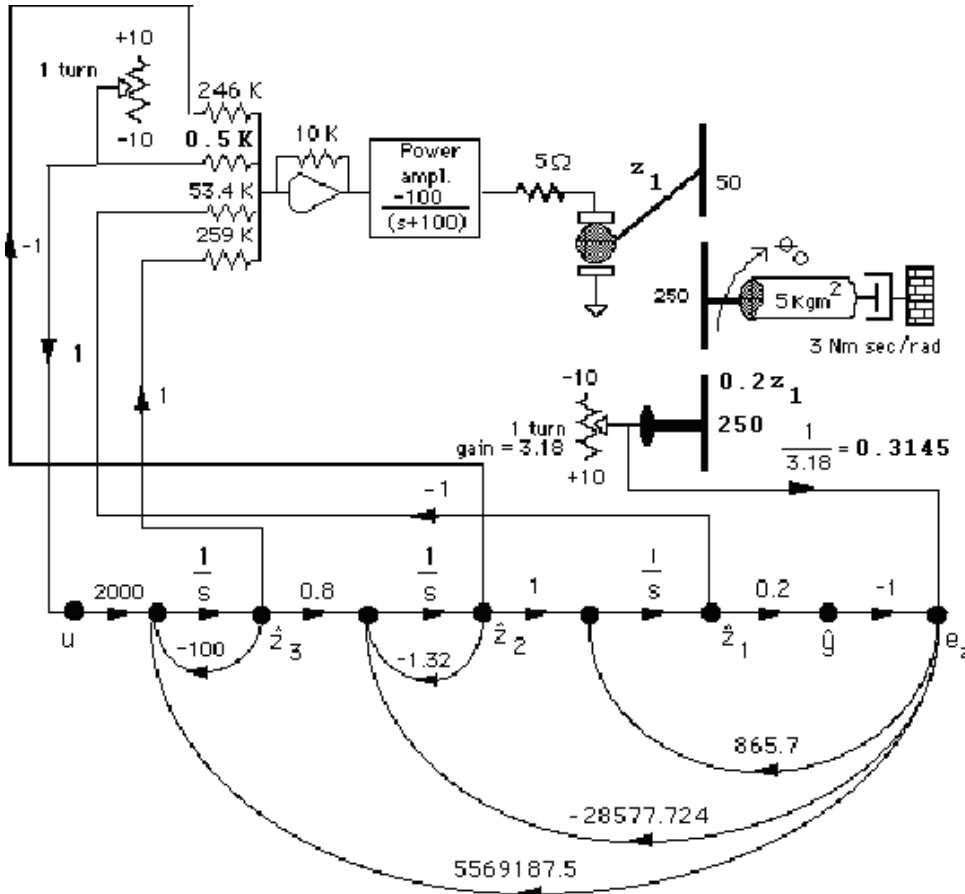

e.

**Program:**

```

'Controller'
A=[0 1 0;0 -1.32 0.8;0 0 -100];
B=[0;0;2000];
C=[0.2 0 0];
D=0;
pos=input('Type desired %OS ');
Ts=input('Type desired settling time ');
z=(-log(pos/100))/(sqrt(pi^2+log(pos/100)^2));
wn=4/(z*Ts); %Calculate required natural
              %frequency.
[num,den]=ord2(wn,z); %Produce a second-order system that
                    %meets the transient response
                    %requirements.
r=roots(den); %Use denominator to specify dominant
              %poles.
poles=[r(1) r(2) 10*real(r(1))];
              %Specify pole placement for all
              %poles.

K=acker(A,B,poles)
'Observer'
pos=input('Type desired %OS ');
z=(-log(pos/100))/(sqrt(pi^2+log(pos/100)^2));
wn=10*wn %Calculate required natural
         %frequency.
[num,den]=ord2(wn,z); %Produce a second-order system that
                    %meets the transient response
                    %requirements.
r=roots(den); %Use denominator to specify dominant
              %poles.
poles=[r(1) r(2) 10*real(r(1))]; %Specify pole placement for all
              %poles.

l=acker(A',C',poles)

```

**Computer response:**

ans =

Controller

```

Type desired %OS 15
Type desired settling time 2

```

K =

```

    0.1871    0.0406   -0.0387

```

ans =

Observer

```

Type desired %OS 10

```

wn =

```

    38.6899

```

l =

```

    1.0e+006 *
    0.0009
   -0.0286
    5.5691

```

## ANSWERS TO REVIEW QUESTIONS

1. Both dominant and non-dominant poles can be specified with state-space design techniques.
2. Feedback all state variables to the plant's input through a variable gain for each. Decide upon a closed-loop characteristic equation that has a pole configuration to yield a desired response. Write the characteristic equation of the actual system. Match coefficients and solve for the values of the variable gains.
3. Phase-variable form
4. The control signal developed by the controller must be able to affect every state variable.
5. If the signal-flow diagram is in the parallel form, which leads to a diagonal system matrix, controllability can be determined by inspection by seeing that all state variables are fed by the control signal.
6. The system is controllable if the determinant of the controllability matrix is non-zero.
7. An observer is a system that estimates the state variables using information from the output of the actual plant.
8. If the plant's state-variables are not accessible, or too expensive to monitor
9. An observer is a copy of the plant. The difference between the plant's output and the observer's output is fed back to each of the derivatives of the observer's state variables through separate variable gains.
10. Dual phase-variable
11. The characteristic equation of the observer is derived and compared to a desired characteristic equation whose roots are poles that represent the desired transient response. The variable gains of each feedback path are evaluated to make the coefficients of the observer's characteristic equation equal the coefficients of the desired characteristic equation.
12. Typically, the transient response of the observer is designed to be much faster than that of the controller. Since the observer emulates the plant, we want the observer to estimate the plant's states rapidly.
13.  $\text{Det}[\mathbf{A}-\mathbf{BK}]$ , where  $\mathbf{A}$  is the system matrix,  $\mathbf{B}$  is the input coupling matrix, and  $\mathbf{K}$  is the controller.
14.  $\text{Det}[\mathbf{A}-\mathbf{LC}]$ , where  $\mathbf{A}$  is the system matrix,  $\mathbf{C}$  is the output coupling matrix, and  $\mathbf{L}$  is the observer.
15. The output signal of the system must be controlled by every state variable.
16. If the signal-flow diagram is in the parallel form, which leads to a diagonal system matrix, observability can be determined by inspection by seeing that all state variables feed the output.
17. The system is observable if the determinant of the observability matrix is non-zero.

## SOLUTIONS TO PROBLEMS

1.

i.  $G(s) = \frac{(s+3)}{(s+4)^2} = \frac{1}{s^2+8s+16} * (s+3)$

a.

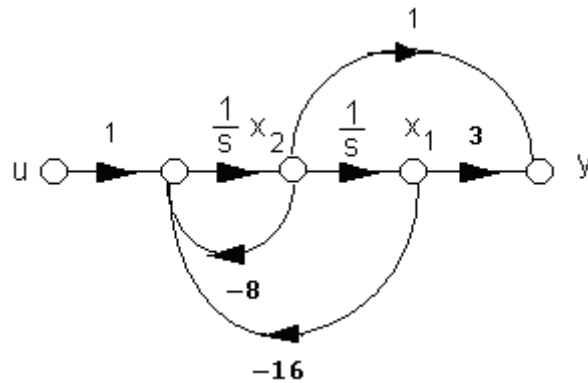

b.

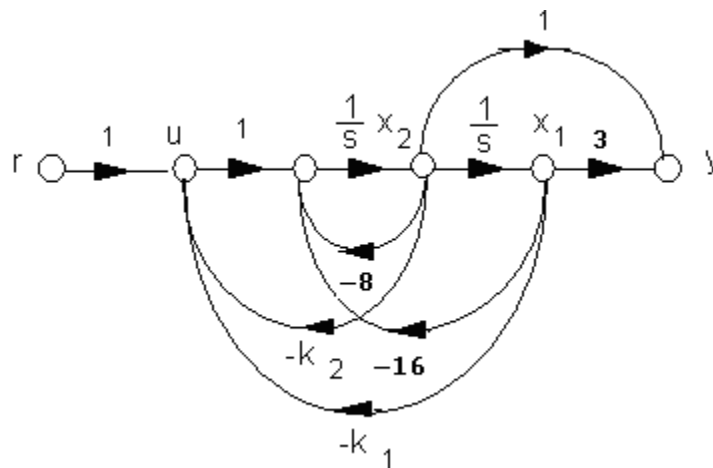

c.

$$\dot{\mathbf{x}} = \begin{bmatrix} 0 & 1 \\ -(k_1+16) & -(k_2+8) \end{bmatrix} \mathbf{x} + \begin{bmatrix} 0 \\ 1 \end{bmatrix} r ; y = \begin{bmatrix} 3 & 1 \end{bmatrix} \mathbf{x}$$



d.

$$T(s) = \frac{s+3}{s^2 + (k_2+8)s + (k_1+16)}$$

$$\dot{\mathbf{x}}_1 = (-20 - 71.25k_1)x_1 - 71.25k_2x_2 - 71.25k_3x_3 + 71.25r$$

$$\dot{\mathbf{x}}_2 = 27.5k_1x_1 + (-10x_2 + 27.5k_2)x_2 + 27.5k_3x_3 - 27.5r$$

$$\dot{\mathbf{x}}_3 = -6.25k_1x_1 - 6.25k_2x_2 - 6.25k_3x_3 + 6.25r$$

$$\mathbf{A} = \begin{bmatrix} (-20 - 71.25k_1) & -71.25k_2 & -71.25k_3 \\ 27.5k_1 & (-10x_2 + 27.5k_2) & 27.5k_3 \\ -6.25k_1 & -6.25k_2 & -6.25k_3 \end{bmatrix}; \mathbf{B} = \begin{bmatrix} 71.25 \\ -27.5 \\ 6.25 \end{bmatrix}; \mathbf{C} = [1 \ 1 \ 1]$$

$$T(s) = \frac{200(s^2 + 7s + 25)}{4s^3 + (120 + 285k_1 - 110k_2 + 25k_3)s^2 + (800 + 2850k_1 - 2200k_2 + 750k_3)s + 5000k_3}$$

e.

Part d. yields same result as i(d).

$$\text{ii. } G(s) = \frac{s}{(s+5)(s+7)} = \frac{1}{s^2 + 12s + 35} * s$$

a.

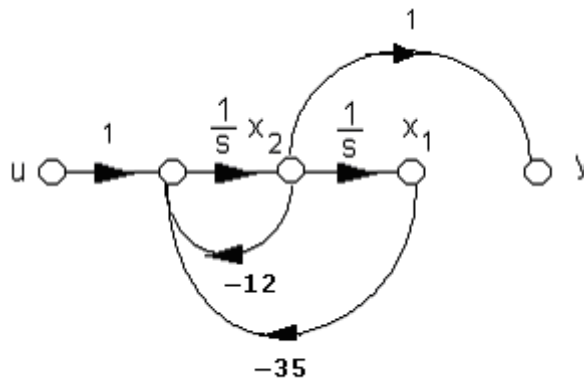

b.

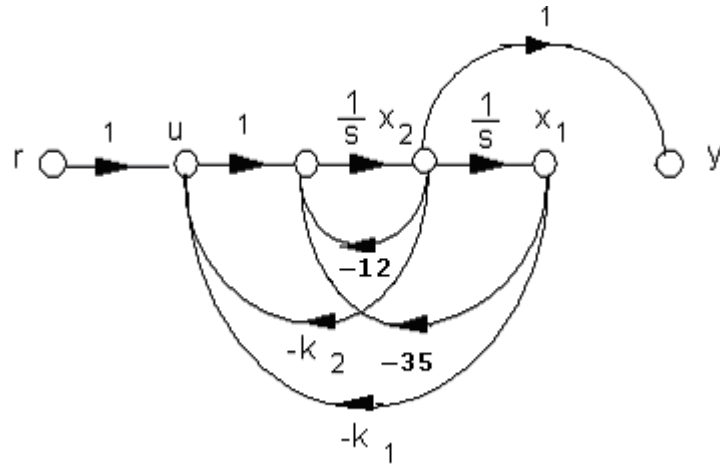

c.

$$\dot{\mathbf{x}} = \begin{bmatrix} 0 & 1 \\ -(k_1+35) & -(k_2+12) \end{bmatrix} \mathbf{x} + \begin{bmatrix} 0 \\ 1 \end{bmatrix} r ; y = [0 \ 1] \mathbf{x}$$

d.

$$T(s) = \frac{s}{s^2 + (k_2+12)s + (k_1+35)}$$

e.

$$T(s) = \mathbf{C}(s\mathbf{I} - \mathbf{A})^{-1}\mathbf{B}; \mathbf{A} = \begin{bmatrix} 0 & 1 \\ -(k_1+35) & -(k_2+12) \end{bmatrix}; \mathbf{B} = \begin{bmatrix} 0 \\ 1 \end{bmatrix}; \mathbf{C} = [0 \ 1]$$

which yields the same result as ii(d).

iii.  $G(s) = \frac{20s(s+7)}{(s+3)(s+7)(s+9)} = \frac{1}{s^3 + 19s^2 + 111s + 189} * (20s^2 + 140s)$

a.

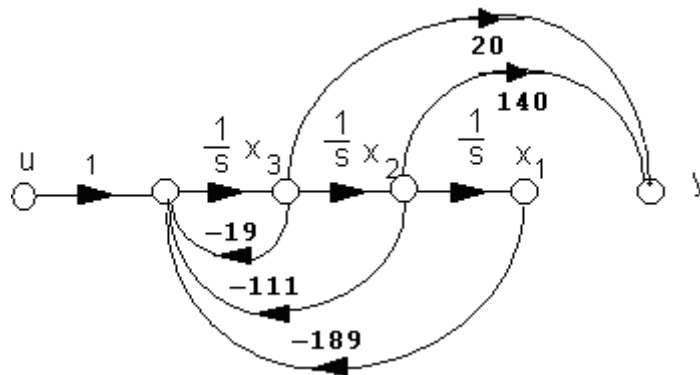

b.

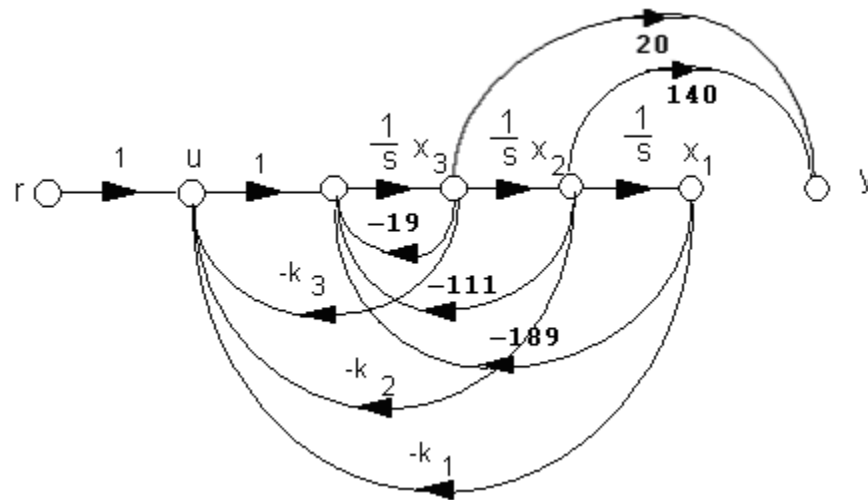

c.

$$\dot{\mathbf{x}} = \begin{bmatrix} 0 & 1 & 0 \\ 0 & 0 & 1 \\ -(k_1+189) & -(k_2+111) & -(k_3+19) \end{bmatrix} \mathbf{x} + \begin{bmatrix} 0 \\ 0 \\ 1 \end{bmatrix} r ; y = [0 \quad 140 \quad 20] \mathbf{x}$$

d.

$$T(s) = \frac{20s(s+7)}{s^3 + (k_3+19)s^2 + (k_2+111)s + (k_1+189)}$$

e.

$$T(s) = \mathbf{C}(s\mathbf{I} - \mathbf{A})^{-1}\mathbf{B}; \mathbf{A} = \begin{bmatrix} 0 & 1 & 0 \\ 0 & 0 & 1 \\ -(k_1+189) & -(k_2+111) & -(k_3+19) \end{bmatrix}; \mathbf{B} = \begin{bmatrix} 0 \\ 0 \\ 1 \end{bmatrix}; \mathbf{C} = [0 \quad 140 \quad 20]$$

which yields the same result as iii(d).

$$\text{iv. } G(s) = \frac{30(s+2)(s+3)}{(s+4)(s+5)(s+6)} = \frac{1}{s^3 + 15s^2 + 74s + 120} * (30s^2 + 150s + 180)$$

a.

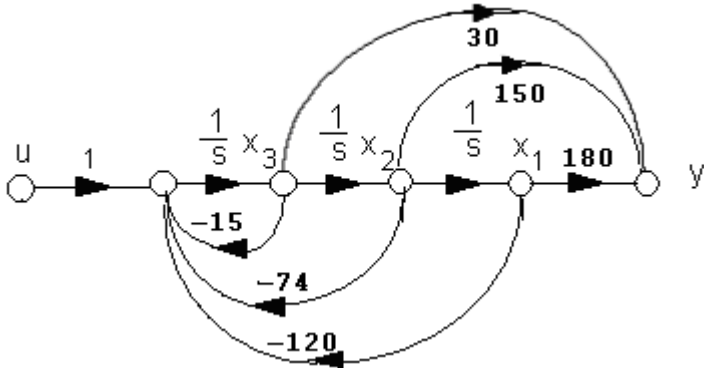

b.

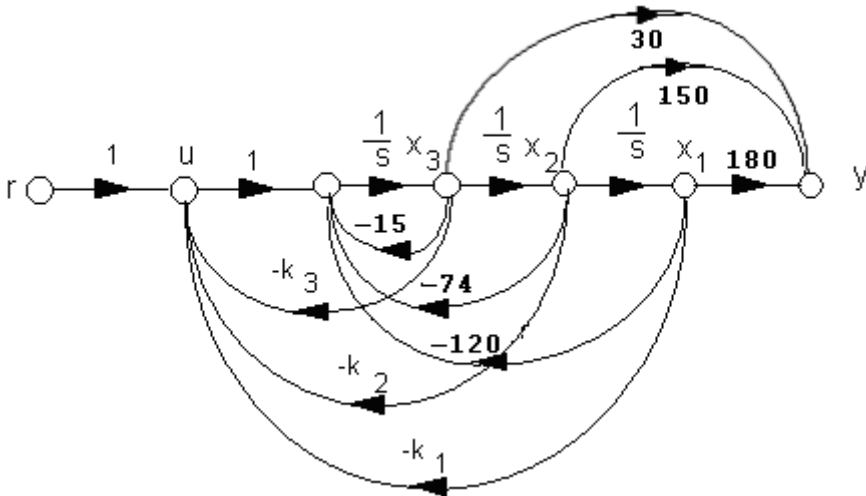

c.

$$\dot{\mathbf{x}} = \begin{bmatrix} 0 & 1 & 0 \\ 0 & 0 & 1 \\ -(k_1+120) & -(k_2+74) & -(k_3+15) \end{bmatrix} \mathbf{x} + \begin{bmatrix} 0 \\ 0 \\ 1 \end{bmatrix} r ; y = [180 \ 150 \ 30] \mathbf{x}$$

d.

$$T(s) = \frac{30s^2 + 150s + 180}{s^3 + (k_3 + 15)s^2 + (k_2 + 74)s + (k_1 + 120)}$$

e.

$$T(s) = \mathbf{C}(s\mathbf{I} - \mathbf{A})^{-1}\mathbf{B}; \mathbf{A} = \begin{bmatrix} 0 & 1 & 0 \\ 0 & 0 & 1 \\ -(k_1 + 120) & -(k_2 + 74) & -(k_3 + 15) \end{bmatrix}; \mathbf{B} = \begin{bmatrix} 0 \\ 0 \\ 1 \end{bmatrix}; \mathbf{C} = [180 \quad 150 \quad 30]$$

which yields the same result as iv(d).

v.  $G(s) = \frac{s^2 + 8s + 15}{(s^2 + 4s + 10)(s^2 + 3s + 12)} = \frac{1}{s^4 + 7s^3 + 34s^2 + 78s + 120} * (s^2 + 8s + 15)$

a.

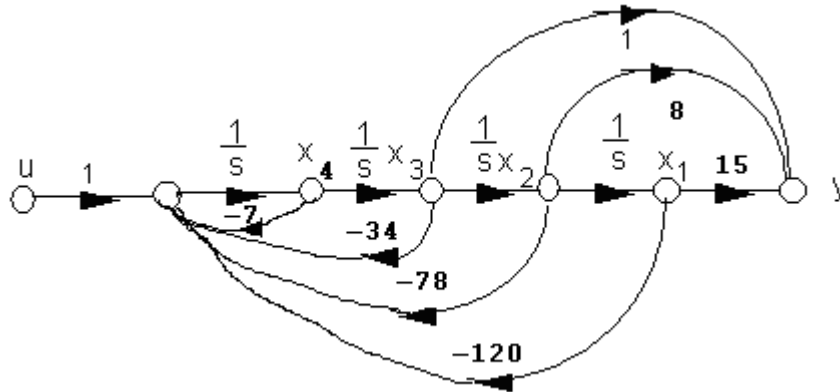

b.

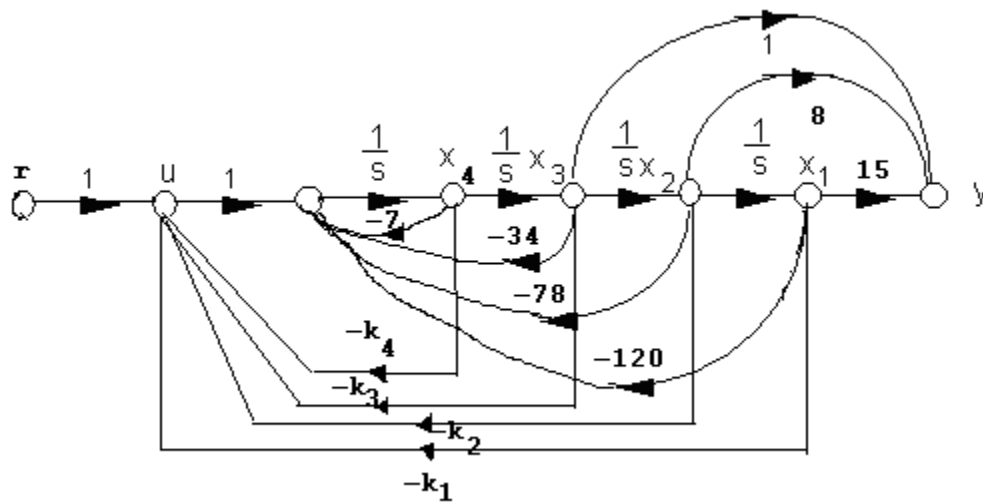

c.

$$\dot{\mathbf{x}} = \begin{bmatrix} 0 & 1 & 0 & 0 \\ 0 & 0 & 1 & 0 \\ 0 & 0 & 0 & 1 \\ -(k_1+120) & -(k_2+78) & -(k_3+34) & -(k_4+7) \end{bmatrix} \mathbf{x} + \begin{bmatrix} 0 \\ 0 \\ 0 \\ 1 \end{bmatrix} r ; y = [15 \ 8 \ 1 \ 0] \mathbf{x}$$

d.

$$T(s) = \frac{s^2 + 8s + 15}{s^4 + (k_4 + 7)s^3 + (k_3 + 34)s^2 + (k_2 + 78)s + (k_1 + 120)}$$

e.

$$T(s) = \mathbf{C}(s\mathbf{I} - \mathbf{A})^{-1}\mathbf{B}; \mathbf{A} = \begin{bmatrix} 0 & 1 & 0 & 0 \\ 0 & 0 & 1 & 0 \\ 0 & 0 & 0 & 1 \\ -(k_1+120) & -(k_2+78) & -(k_3+34) & -(k_4+7) \end{bmatrix}; \mathbf{B} = \begin{bmatrix} 0 \\ 0 \\ 0 \\ 1 \end{bmatrix}; \mathbf{C} = [15 \ 8 \ 1 \ 0]$$

which yields the same result as v(d).

2.

i

a. The output is

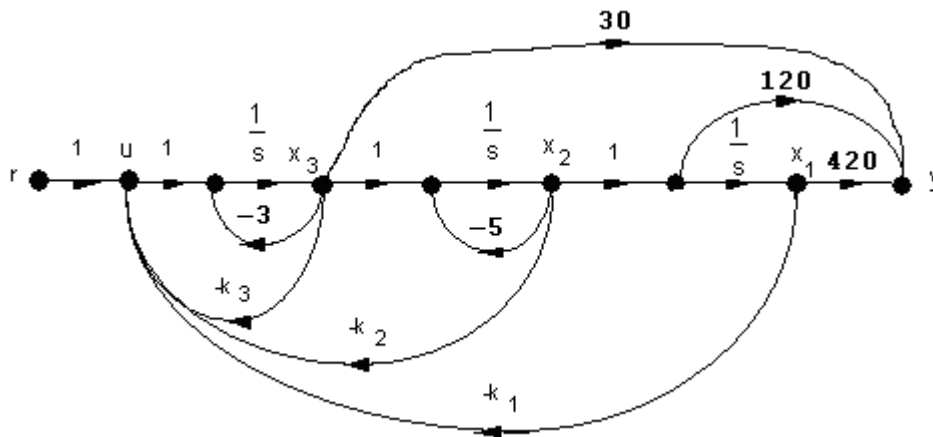

Since,

$$y = (30s^2 + 270s + 420)x_1 = 30\ddot{x}_1 + 270\dot{x}_1 + 420x_1 = 30\dot{x}_2 + 270x_2 + 420x_1$$

$$= 30(-5x_2 + x_3) + 270x_2 + 420x_1 = 420x_1 + 120x_2 + 30x_3$$

b.

$$T(s) = \mathbf{C}(s\mathbf{I} - \mathbf{A})^{-1}\mathbf{B}; \mathbf{A} = \begin{bmatrix} 0 & 1 & 0 \\ 0 & -5 & 1 \\ -k_1 & -k_2 & -(k_3 + 3) \end{bmatrix}; \mathbf{B} = \begin{bmatrix} 0 \\ 0 \\ 1 \end{bmatrix}; \mathbf{C} = [420 \quad 120 \quad 30]$$

$$T(s) = \frac{30(s+2)(s+7)}{s^3(k_3+8)s^2 + (5k_3+k_2+15)s + k_1}$$

ii

a.

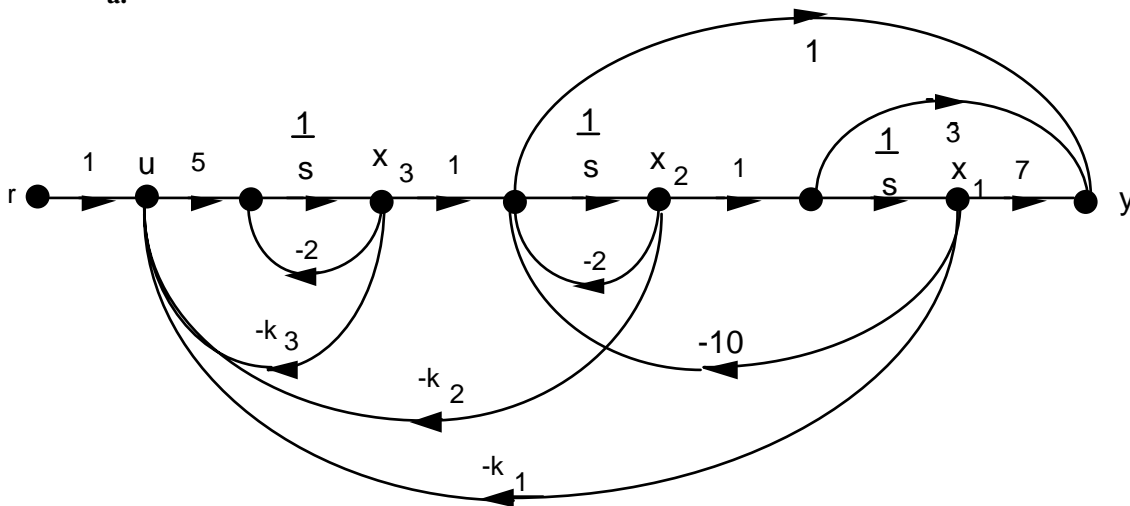

b.

$$T(s) = \mathbf{C}(s\mathbf{I} - \mathbf{A})^{-1}\mathbf{B}; \mathbf{A} = \begin{bmatrix} 0 & 1 & 0 \\ 0 & 0 & 1 \\ -k_1 & -k_2 & -(5k_3 + 2) \end{bmatrix}; \mathbf{B} = \begin{bmatrix} 0 \\ 0 \\ 5 \end{bmatrix}; \mathbf{C} = [-3 \quad 1 \quad 1]$$

$$= \frac{5(s^2 + 3s + 7)}{s^3 + (5k_3 + 4)s^2 + (10k_3 + k_2 + 14)s + (50k_3 + k_1 + 20)}$$

3.

i  
a.

$$G(s) = \frac{50(s^2 + 7s + 25)}{s(s+10)(s+20)} = \frac{6.25}{s} - \frac{27.5}{s+10} + \frac{71.25}{s+20}$$

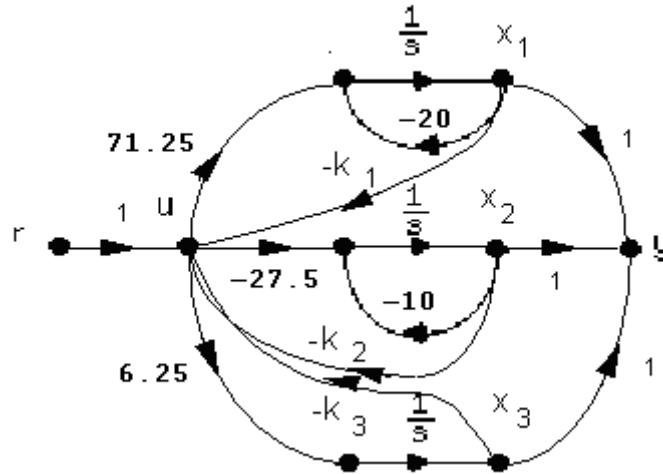

b. Writing the state equations:

$$\begin{aligned} \dot{x}_1 &= -20x_1 + 71.25u \\ \dot{x}_2 &= -10x_2 - 27.5u \\ \dot{x}_3 &= 6.25u \end{aligned}$$

But,  $u = -k_1x_1 - k_2x_2 - k_3x_3 + r$ . Substituting into the state equations,

$$\begin{aligned} \dot{x}_1 &= (-20 - 71.25k_1)x_1 - 71.25k_2x_2 - 71.25k_3x_3 + 71.25r \\ \dot{x}_2 &= 27.5k_1x_1 + (-10x_2 + 27.5k_2)x_2 + 27.5k_3x_3 - 27.5r \\ \dot{x}_3 &= -6.25k_1x_1 - 6.25k_2x_2 - 6.25k_3x_3 + 6.25r \end{aligned}$$

Therefore,  $T(s) = C(s\mathbf{I} - \mathbf{A})^{-1}\mathbf{B}$ , where

$$\mathbf{A} = \begin{bmatrix} (-20 - 71.25k_1) & -71.25k_2 & -71.25k_3 \\ 27.5k_1 & (-10x_2 + 27.5k_2) & 27.5k_3 \\ -6.25k_1 & -6.25k_2 & -6.25k_3 \end{bmatrix}; \mathbf{B} = \begin{bmatrix} 71.25 \\ -27.5 \\ 6.25 \end{bmatrix}; \mathbf{C} = [1 \quad 1 \quad 1]$$

Hence,



$$T(s) = \frac{200(s^2 + 7s + 25)}{4s^3 + (120 + 285k_1 - 110k_2 + 25k_3)s^2 + (800 + 2850k_1 - 2200k_2 + 750k_3)s + 5000k_3}$$

ii  
a.

$$G(s) = \frac{50(s+3)(s+4)}{(s+5)(s+6)(s+7)} = \frac{50}{s+5} - \frac{300}{s+6} + \frac{300}{s+7}$$

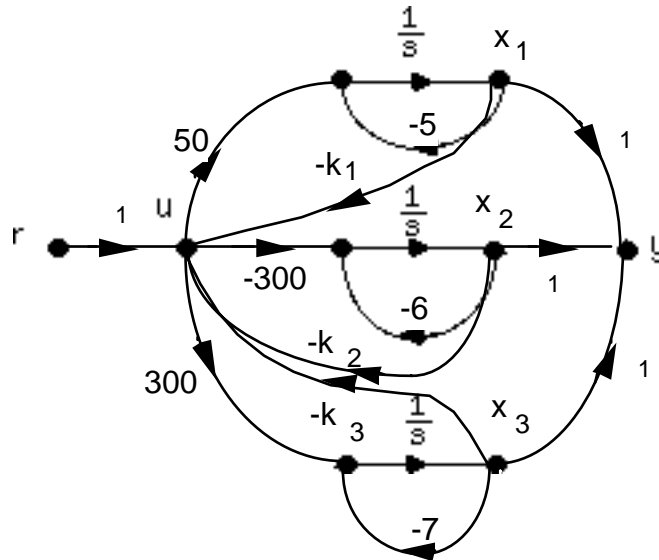

b. Writing the state equations:

$$\begin{aligned} \dot{x}_1 &= -5x_1 + 50u \\ \dot{x}_2 &= -6x_2 - 300u \\ \dot{x}_3 &= -7x_3 + 300u \end{aligned}$$

But,

$$u = -k_1x_1 - k_2x_2 - k_3x_3 + r$$

Substituting into the state equations, collecting terms, and converting to vector-matrix form yields

$$\begin{aligned} \dot{\mathbf{x}} &= \begin{bmatrix} -(5+k_1) & -50k_2 & -50k_3 \\ 300k_1 & (300k_2-6) & 300k_3 \\ -(300k_1+7) & -300k_2 & 300k_3 \end{bmatrix} \mathbf{x} + \begin{bmatrix} 50 \\ -300 \\ 300 \end{bmatrix} r \\ y &= [1 \quad 1 \quad 1] \mathbf{x} \end{aligned}$$

Therefore,  $T(s) = C(sI - A)^{-1}B$ , or

$$T(s) = \frac{50s^2 + 1750s + (6900 - 88200k_1)}{s^3 + (300k_3 - 300k_2 + k_1 + 11)s^2 + 2(1475k_3 - 750k_2 + 3k_1 - 7350k_3k_1 + 7350k_2k_1 + 15)s + 300k_3(23 - 294k_1)}$$

4.

The plant is given by

$$G(s) = \frac{20}{(s+2)(s+4)(s+8)} = \frac{20}{s^3 + 14s^2 + 56s + 64}$$

The characteristic polynomial for the plant with phase-variable state feedback is

$$s^3 + (k_3 + 14)s^2 + (k_2 + 56)s + (k_1 + 64) = 0$$

The desired characteristic equation is

$$(s + 53.33)(s^2 + 10.67s + 106.45) = s^3 + 64s^2 + 675.48s + 5676.98$$

based upon 15% overshoot,  $T_s = 0.75$  second, and a third pole ten times further from the imaginary axis than the dominant poles. Comparing the two characteristic equations,

$$k_1 = 5612.98, k_2 = 619.48, \text{ and } k_3 = 50.$$

5.

a. The system in controller canonical form is:

$$\mathbf{A} = \begin{bmatrix} -a_{n-1} & -a_{n-2} & \cdots & -a_1 & -a_0 \\ 1 & 0 & \cdots & 0 & 0 \\ \vdots & \vdots & \vdots & \vdots & \vdots \\ 0 & 0 & \cdots & 1 & 0 \end{bmatrix}; \mathbf{B} = \begin{bmatrix} 1 \\ 0 \\ 0 \\ 0 \end{bmatrix}; \mathbf{C} = [c_1 \quad c_2 \quad c_3 \quad c_4]$$

The characteristic equation of the plant is:

$$s^n + a_{n-1}s^{n-1} + \dots + a_1s + a_0 = 0$$

Forming the closed-loop system by feeding back each state variable and the input to  $u$  forming

$$u = -\mathbf{K}\mathbf{x} + r$$

where

$$\mathbf{K} = [k_1 \quad k_2 \quad \dots \quad k_n]$$

and substituting  $u$  into the state equation, we obtain

$$\dot{\mathbf{x}} = \mathbf{A}\mathbf{x} + \mathbf{B}u = (\mathbf{A} - \mathbf{BK})\mathbf{x} + \mathbf{B}r$$

Forming  $\mathbf{A} - \mathbf{BK}$ :

$$\mathbf{A} - \mathbf{BK} = \begin{bmatrix} -(a_{n-1} + k_1) & -(a_{n-2} + k_2) & \cdots & -(a_1 + k_{n-1}) & -(a_0 + k_n) \\ 1 & 0 & \cdots & 0 & 0 \\ \vdots & \vdots & \vdots & \vdots & \vdots \\ 0 & 0 & \cdots & 1 & 0 \end{bmatrix}$$

The characteristic equation is:

$$s^n + (a_{n-1} + k_1)s^{n-1} + (a_{n-2} + k_2)s^{n-2} + \dots + (a_1 + k_{n-1})s + (a_0 + k_n) = 0$$

Assuming a desired characteristic equation,

$$s^n + d_{n-1}s^{n-1} + d_{n-2}s^{n-2} + \dots + d_2s^2 + d_1s + d_0 = 0$$

Equating coefficients,

$$d_i = a_i + k_{n-i}; i = 0, 1, 2, \dots, n-1$$

from which

$$k_{n-i} = d_i - a_i \tag{1}$$

**b.** The desired characteristic equation is

$$s^3 + 15.9s^2 + 136.08s + 413.1 = 0$$

the characteristic equation of the plant is

$$s^3 + 5s^2 + 4s + 0 = 0$$

Using Eq. (1) above,  $k_{3-i} = d_i - a_i$ . Therefore,  $k_3 = d_0 - a_0 = 413.1 - 0 = 413.1$ ;  $k_2 = d_1 - a_1 = 136.08 - 4 = 132.08$ ;  $k_1 = d_2 - a_2 = 15.9 - 5 = 10.9$ . Hence,

$$\mathbf{K} = [10.9 \quad 132.08 \quad 413.1]$$

**6.**

Using Eqs. (4.39) and (4.34) to find  $\zeta = 0.5169$  and  $\omega_n = 7.3399$ , respectively. Factoring the denominator of Eq. (4.22), the required poles are  $-3.7942 \pm j6.2832$ . We place the third pole at -2 to cancel the open loop zero. Multiplying the three closed-loop pole terms yields the desired characteristic equation:

$$s^3 + 9.5885s^2 + 69.0516s + 107.7493 = 0. \text{ Since } G(s) = \frac{100s^2 + 2200s + 4000}{s^3 + 8s^2 + 19s + 12}, \text{ the controller}$$

$$\text{canonical form is } \mathbf{A} = \begin{bmatrix} -8 & -19 & -12 \\ 1 & 0 & 0 \\ 0 & 1 & 0 \end{bmatrix}; \mathbf{B} = \begin{bmatrix} 1 \\ 0 \\ 0 \end{bmatrix}; \mathbf{C} = [100 \quad 2200 \quad 4000]. \text{ The first row of } \mathbf{A}$$

contains the coefficients of the characteristic equation. Thus comparing the first row of  $\mathbf{A}$  to the desired characteristic equation and using the results of Problem 5,  $k_1 = -(9.5885 - 8) = 1.5885$ ;  $k_2 = -(69.0516 - 19) = 50.0516$ ; and  $k_3 = -(107.7493 - 12) = 95.7493$ .

**7.**

The plant is given by

$$G(s) = \frac{20(s+2)}{s(s+5)(s+7)} = \frac{20s+40}{s^3+12s^2+35s+0}$$

The characteristic polynomial for the plant with phase-variable state feedback is

$$s^3 + (k_3 + 12)s^2 + (k_2 + 35)s + (k_3 + 0)$$

The desired characteristic equation is

$$(s+20)(s^2+4s+11.45) = s^3 + 24s^2 + 91.45s + 229$$

based upon 10% overshoot,  $T_s = 2$  seconds, and a third pole ten times further from the imaginary axis than the dominant poles. Comparing the two characteristic equations,

$$k_1 = 229, k_2 = 56.45, \text{ and } k_3 = 12.$$

8. Drawing the signal-flow diagram,

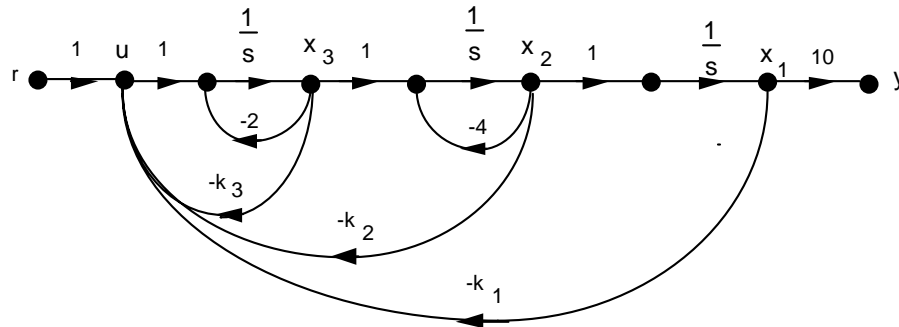

Writing the state equations yields the following **A** matrix:

$$\mathbf{A} = \begin{pmatrix} 0 & 1 & 0 \\ 0 & -4 & 1 \\ -k_1 & -k_2 & -[2+k_3] \end{pmatrix}$$

from which,

$$|s\mathbf{I} - \mathbf{A}| = s^3 + (k_3 + 6)s^2 + (4k_3 + k_2 + 8)s + k_1$$

The desired characteristic equation is  $(s+80)(s^2+16s+183.137) = s^3 + 96s^2 + 1463.1s + 14651$  based upon 10% overshoot,  $T_s = 0.5$  second, and a third pole ten times further from the imaginary axis than the dominant poles. Comparing the two characteristic equations,  $k_1 = 14651$ ,  $k_2 = 1095.1$ , and  $k_3 = 90$ .

9. Expand  $G(s)$  by partial fractions and obtain

$$G(s) = \frac{20}{s(s+4)(s+6)} = \frac{1.67}{s} + \frac{5}{s+4} - \frac{6.67}{s+6}$$

Drawing the signal-flow diagram with state feedback

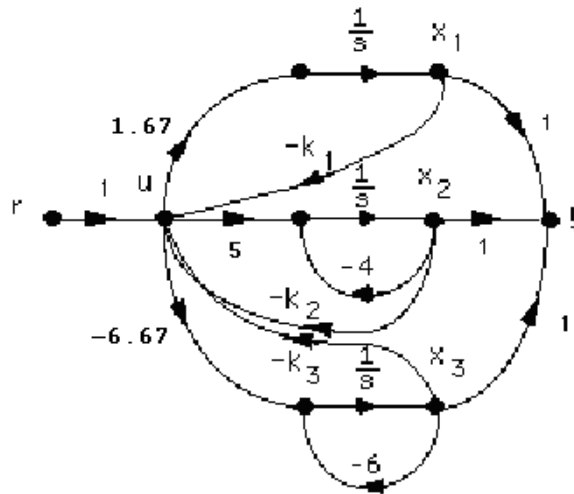

Writing the state equations yields the following system matrix:

$$\mathbf{A} = \begin{bmatrix} -1.67k_1 & -1.67k_2 & -1.67k_3 \\ -5k_1 & -(5k_2 + 4) & -5k_3 \\ 6.67k_1 & 6.67k_2 & (6.67k_3 - 6) \end{bmatrix}$$

Evaluating the characteristic polynomial yields,

$$|s\mathbf{I} - \mathbf{A}| = (-6.67k_3 + 5k_2 + 1.67k_1 + 10)s^2 + (-26.68k_3 + 30k_2 + 16.7k_1 + 24)s + 40.08k_1$$

From Problem 7, the desired characteristic polynomial is

$$s^3 + 24s^2 + 91.45s + 229.$$

Equating coefficients and solving simultaneously yields

$$k_1 = 5.71, k_2 = -4.58, \text{ and } k_3 = -4.10.$$

**10.**

Writing the state equation and the controllability matrix for the system yields

$$\dot{\mathbf{x}} = \begin{bmatrix} -5 & 1 \\ -1 & -3 \end{bmatrix} \mathbf{x} + \begin{bmatrix} b_1 \\ b_2 \end{bmatrix} u; \mathbf{C}_M = [\mathbf{B} \quad \mathbf{AB}] = \begin{bmatrix} b_1 & -5b_1 + b_2 \\ b_2 & -b_1 - 3b_2 \end{bmatrix}$$

The controllability matrix has a zero determinant if  $b_2 = b_1$ .

**11.**

The controllability matrix is given by Eq. (12.26) for each of the following solutions:

a.

$$\mathbf{A} = \begin{bmatrix} -2 & 0 & 1 \\ 0 & -2 & 0 \\ 0 & 0 & -3 \end{bmatrix}; \mathbf{B} = \begin{bmatrix} 0 \\ 1 \\ 1 \end{bmatrix}; \mathbf{C}_M = \begin{bmatrix} 0 & 1 & -5 \\ 1 & -2 & 4 \\ 1 & -3 & 9 \end{bmatrix}; \det \mathbf{C}_M = 0; \text{ system is uncontrollable}$$

b.

$$\mathbf{A} = \begin{bmatrix} -2 & 1 & 0 \\ 0 & -2 & 0 \\ 0 & 0 & -3 \end{bmatrix}; \mathbf{B} = \begin{bmatrix} 0 \\ 1 \\ 1 \end{bmatrix}; \mathbf{C}_M = \begin{bmatrix} 0 & 1 & -4 \\ 1 & -2 & 4 \\ 1 & -3 & 9 \end{bmatrix}; \det \mathbf{C}_M = -1; \text{ system is controllable}$$

c.

$$\mathbf{A} = \begin{bmatrix} -4 & 1 & 0 \\ 0 & 0 & 1 \\ 0 & 0 & -3 \end{bmatrix}; \mathbf{B} = \begin{bmatrix} 0 \\ 2 \\ 1 \end{bmatrix}; \mathbf{C}_M = \begin{bmatrix} 0 & 2 & -7 \\ 2 & 1 & -3 \\ 1 & -3 & 9 \end{bmatrix}; \det \mathbf{C}_M = 7; \text{ system is controllable}$$

d.

$$\mathbf{A} = \begin{bmatrix} -4 & 1 & 0 \\ 0 & 0 & 1 \\ -5 & 0 & -3 \end{bmatrix}; \mathbf{B} = \begin{bmatrix} 1 \\ 0 \\ 1 \end{bmatrix}; \mathbf{C}_M = \begin{bmatrix} 1 & -4 & 17 \\ 0 & 1 & -8 \\ 1 & -8 & 44 \end{bmatrix}; \det \mathbf{C}_M = -5; \text{ system is controllable}$$

e.

$$\mathbf{A} = \begin{bmatrix} 0 & 1 \\ -6 & -5 \end{bmatrix}; \mathbf{B} = \begin{bmatrix} 1 \\ -2 \end{bmatrix}; \mathbf{C}_M = \begin{bmatrix} 1 & -2 \\ -2 & 4 \end{bmatrix}; \det \mathbf{C}_M = 0; \text{ system is uncontrollable}$$

f.

$$\mathbf{A} = \begin{bmatrix} -4 & 0 & 0 \\ 0 & -5 & 0 \\ 0 & 0 & -6 \end{bmatrix}; \mathbf{B} = \begin{bmatrix} 1 \\ 0 \\ 1 \end{bmatrix}; \mathbf{C}_M = \begin{bmatrix} 1 & -4 & 16 \\ 0 & 0 & 0 \\ 1 & -6 & 36 \end{bmatrix}; \det \mathbf{C}_M = 0; \text{ system is uncontrollable}$$

This system can also be determined uncontrollable by inspection.

12.

**Program:**

```
'(d)'  
A=[-4 1 0;0 0 1;-5 0 -3]  
B=[1;0;1]  
Cm=ctrb(A,B)  
Rank=rank(Cm)  
pause  
'(f)'  
A=[-4 0 0;0 -5 0;0 0 -6]  
B=[1;0;1]  
Cm=ctrb(A,B)  
Rank=rank(Cm)
```

**Computer response:**

ans =

(d)

A =

$$\begin{bmatrix} -4 & 1 & 0 \\ 0 & 0 & 1 \\ -5 & 0 & -3 \end{bmatrix}$$

B =

$$\begin{bmatrix} 1 \\ 0 \\ 1 \end{bmatrix}$$

Cm =

$$\begin{bmatrix} 1 & -4 & 17 \\ 0 & 1 & -8 \\ 1 & -8 & 44 \end{bmatrix}$$

Rank =

3

ans =

(f)

A =

$$\begin{bmatrix} -4 & 0 & 0 \\ 0 & -5 & 0 \\ 0 & 0 & -6 \end{bmatrix}$$

B =

$$\begin{bmatrix} 1 \\ 0 \\ 1 \end{bmatrix}$$

Cm =

$$\begin{bmatrix} 1 & -4 & 16 \\ 0 & 0 & 0 \\ 1 & -6 & 36 \end{bmatrix}$$

Rank =

2

**13.**

From Eq. (12.46) we write the controller canonical form:  $\mathbf{A}_{cc} = \begin{bmatrix} -8 & -17 & -10 \\ 1 & 0 & 0 \\ 0 & 1 & 0 \end{bmatrix}$ ;  $\mathbf{B}_{cc} = \begin{bmatrix} 1 \\ 0 \\ 0 \end{bmatrix}$ .

The controllability matrices are found using Eq. (12.35). For the original system of Eq. (12.44),

$$\mathbf{C}_{Mz} = \begin{bmatrix} 0 & 0 & 1 \\ 0 & 1 & -3 \\ 1 & -1 & 1 \end{bmatrix}. \text{ For the controller canonical form, } \mathbf{C}_{Mcc} = \begin{bmatrix} 1 & -8 & 47 \\ 0 & 1 & -8 \\ 0 & 0 & 1 \end{bmatrix}. \text{ The transformation}$$

$$\text{matrix is, } \mathbf{P} = \mathbf{C}_{Mz}\mathbf{C}_{Mcc}^{-1} = \begin{bmatrix} 0 & 0 & 1 \\ 0 & 1 & 5 \\ 1 & 7 & 10 \end{bmatrix}. \text{ Comparing the first row of } \mathbf{A}_{cc} \text{ with the desired}$$

characteristic equation, Eq. (12.50),  $\mathbf{K}_{cc} = [-2 \quad -4 \quad 10]$ . Transforming back to the original system,  $\mathbf{K}_z = \mathbf{K}_{cc}\mathbf{P}^{-1} = [-20 \quad 10 \quad -2]$ .

14.

Drawing the signal-flow diagram for the plant in cascade form yields

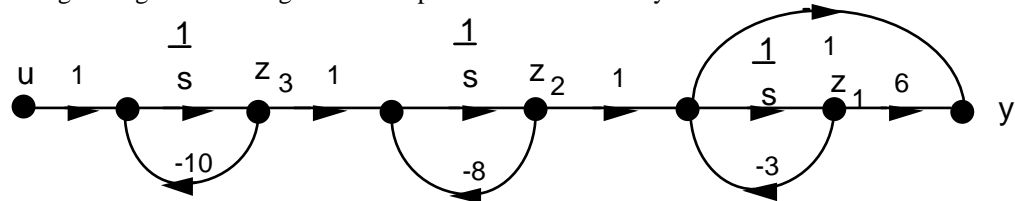

Writing the **A** and **B** matrices for the z system,

<b>Az</b>				<b>Bz</b>
-3	1	0	0	0
0	-8	1	0	0
0	0	-10	1	1

Writing the **A** and **B** matrices for the x (phase-variable) system,

<b>Ax</b>				<b>Bx</b>	
0	1	0	0	0	
0	0	1	0	0	Phase-Variable Form
-240	-134	-21	1	1	

From the phase variable form, the characteristic polynomial is  $s^3 + 21s^2 + 134s + 240$ .

Finding the controllability matrices and their determinants for the z and x systems shows that there is controllability,

<b>CMz</b>	Controllability Matrix of z			<b>CMx</b>	Controllability Matrix of x		
0	0	1		0	0	1	
0	1	-18		0	1	-21	
1	-10	100		1	-21	307	
<b>Det(CMz)</b>	-1			<b>Det(CMx)</b>	-1		



Using Eq. (12.39), the transformation matrix  $\mathbf{P}$  and its inverse are found to be

$\mathbf{P}$	Transformation Matrix $z=Px$		$\mathbf{PINV}$		
1	0	0	1.00	0.00	0.00
3	1	0	-3.00	1.00	0.00
24	11	1	9.00	-11.00	1.00

Using the given transient requirements, and placing the third closed-loop pole over the zero at -6 yields the following desired closed-loop characteristic polynomial:

$$(s^2 + 8s + 45.78)(s + 6) = s^3 + 14s^2 + 93.78s + 274.68$$

Using the phase-variable system with state feedback the characteristic polynomial is

$$s^3 + (k_3 + 21)s^2 + (k_2 + 134)s + (k_1 + 240)$$

Equating the two characteristic polynomials yields the state feedback vector for the  $x$  system as

$\mathbf{Kx}$	Controller for $x$	
34.68	-40.22	-7

Using Eq. (12.42),

$\mathbf{Kz}$	Controller for $z$	
92.34	36.78	-7

### 15.

#### Program:

```
A=[-3 1 0;0 -8 1;0 0 -10]; %Generate system matrix A
B=[0;0;1]; %Generate input coupling matrix B
C=[3 1 0]; %Generate output coupling matrix C
D=0; %Generate matrix D
Po=10; %Input desired percent overshoot
Ts=1; %Input desired settling time
z=(-log(Po/100))/(sqrt(pi^2+log(Po/100)^2)); %Calculate required damping ratio
wn=4/(z*Ts); %Calculate required natural
%frequency
[num,den]=ord2(wn,z); %Produce a second-order system that
%meets transient requirements
r=roots(den); %Use denominator to specify
%dominant poles
poles=[r(1) r(2) -6]; %Specify pole placement for all
%poles.
%A few tries at the the third-pole
%value shows T(s) with a closed-
%loop zero at -7.
%Thus, choose the third pole to
%cancel this zero.
K=acker(A,B,poles) %Calculate controller gains in z-
%system
Anew=A-B*K; %Form compensated A matrix
Bnew=B; %Form compensated B matrix
Cnew=C; %Form compensated C matrix
Dnew=D; %Form compensated D matrix
[numt,dent]=ss2tf(Anew,Bnew,Cnew,Dnew); %Form T(s)
'T(s)' %Display label
T=tf(numt,dent) %Display T(s)
poles=pole(T) %Display poles of T(s)
```

**Computer response:**

```

K =
    92.3531    36.7844   -7.0000

ans =

T(s)

Transfer function:
   -3.553e-015 s^2 + s + 6
-----
  s^3 + 14 s^2 + 93.78 s + 274.7

poles =

   -4.0000 + 5.4575i
   -4.0000 - 5.4575i
   -6.0000
    
```

16. Expanding by partial fractions,

$$G(s) = \frac{(s+6)}{(s+3)(s+8)(s+10)} = \frac{0.085714}{(s+3)} - \frac{0.2}{(s+8)} - \frac{0.28571}{(s+10)}$$

Writing the **A** and **B** matrices for the z system with k<sub>i</sub>'s set to zero,

<b>Az</b>				<b>Bz</b>
-3	0	0		0.085714
0	-8	0		0.2
0	0	-10		-0.28571

Writing the **A** and **B** matrices for the x (phase-variable) system,

<b>Ax</b>			<b>Bx</b>	
0	1	0	0	
0	0	1	0	Phase-Variable Form
-240	-134	-21	1	

From the phase variable form, the characteristic polynomial is  $s^3 + 21s^2 + 134s + 240$ .

Finding the controllability matrices and their determinants for the z and x systems shows that there is controllability,

<b>CMz</b>	Controllability Matrix of z		<b>CMx</b>	Controllability Matrix of x	
0.085714	-0.257142	0.771426	0	0	1
0.2	-1.6	12.8	0	1	-21
-0.28571	2.8571	-28.571	1	-21	307
<b>Det(CMz)</b>	0.342850857		<b>Det(CMx)</b>	-1	

Using Eq. (12.39), the transformation matrix **P** and its inverse are found to be

<b>P</b>	Transformation Matrix $z=Px$		<b>PINV</b>		
6.85712	1.542852	0.085714	0.33	-0.50	-0.25
6	2.6	0.2	-1.00	4.00	2.50
-6.85704	-3.14281	-0.28571	3.00	-32.00	-25.00

Using the given transient requirements, and placing the third closed-loop pole over the zero at -6 yields the following desired closed-loop characteristic polynomial:

$$(s^2 + 8s + 45.78)(s + 6) = s^3 + 14s^2 + 93.78s + 274.68$$

Using the phase-variable system with state feedback the characteristic polynomial is

$$s^3 + (k_3 + 21)s^2 + (k_2 + 134)s + (k_1 + 240)$$

Equating the two characteristic polynomials yields the state feedback vector for the  $x$  system as

<b>Kx</b>	Controller for $x$	
34.7062	-40.2156	-7

Using Eq. (12.42),

<b>Kz</b>	Controller for $z$	
30.78443595	45.7845	65.78543678

17. Draw signal-flow diagram showing state variables,  $z$ , at the output of each subsystem and the state variables,  $w$ , at the output of the integrators.

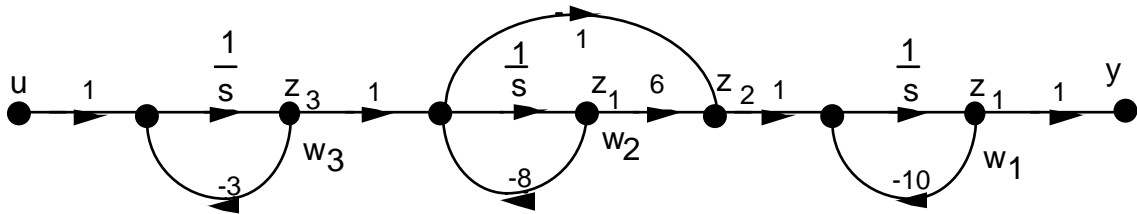

Recognizing that  $z_2 = 6w_2 - 8w_2 + w_3 = -2w_2 + w_3$ , we can write the state equations for  $w$  as

$$\dot{\mathbf{w}} = \begin{bmatrix} -10 & -2 & 1 \\ 0 & -8 & 1 \\ 0 & 0 & -3 \end{bmatrix} \mathbf{w} + \begin{bmatrix} 0 \\ 0 \\ 1 \end{bmatrix} u$$

$$y = [1 \ 0 \ 0] \mathbf{w}$$

Writing the relationship between  $z$  and  $w$  yields

$$\mathbf{z} = \begin{bmatrix} 1 & 0 & 0 \\ 0 & -2 & 1 \\ 0 & 0 & 1 \end{bmatrix} \mathbf{w} = \mathbf{P}^{-1} \mathbf{w}$$

Thus

$$\mathbf{P} = \begin{bmatrix} 1 & 0 & 0 \\ 0 & -0.5 & 0.5 \\ 0 & 0 & 1 \end{bmatrix}$$

Converting the state equations in  $\mathbf{w}$  to state equations in  $\mathbf{z}$ , we use Eqs. (5.87) and obtain the  $\mathbf{A}$  matrix and  $\mathbf{B}$  vector as

<b>Az</b>				<b>Bz</b>
-10	1	0		0
0	-8	3		1
0	0	-3		1

Writing the  $\mathbf{A}$  and  $\mathbf{B}$  matrices for the  $x$  (phase-variable) system,

<b>Ax</b>				<b>Bx</b>	
0	1	0		0	
0	0	1		0	Phase-Variable Form
-240	-134	-21		1	

From the phase variable form, the characteristic polynomial is  $s^3 + 21s^2 + 134s + 240$

Finding the controllability matrices and their determinants for the  $z$  and  $x$  systems shows that there is controllability,

<b>CMz</b>	Controllability Matrix of $z$			<b>CMx</b>	Controllability Matrix of $x$		
0	1	-15		0	0	1	
1	-5	31		0	1	-21	
1	-3	9		1	-21	307	
<b>Det(CMz)</b>	-8			<b>Det(CMx)</b>	-1		

Using Eq. (12.39), the transformation matrix  $\mathbf{P}$  and its inverse are found to be

<b>P</b>	Transformation Matrix $z=Px$			<b>PINV</b>		
6	1	0		-0.25	-0.13	0.13
60	16	1		2.50	0.75	-0.75
80	18	1		-25.00	-3.50	4.50

Using the given transient requirements, and placing the third closed-loop pole over the zero at  $-6$  yields the following desired closed-loop characteristic polynomial:

$$(s^2 + 8s + 45.78)(s + 6) = s^3 + 14s^2 + 93.78s + 274.68$$

Using the phase-variable system with state feedback the characteristic polynomial is

$$s^3 + (k_3 + 21)s^2 + (k_2 + 134)s + (k_1 + 240)$$

Equating the two characteristic polynomials yields the state feedback vector for the  $x$  system as

$$\begin{array}{rcc} \mathbf{Kx} & \text{Controller for } x & \\ 34.68 & -40.22 & -7 \end{array}$$

Using Eq. (12.42),

$$\begin{array}{rcc} \mathbf{Kz} & \text{Controller for } z & \\ 65.78 & -10 & 3 \end{array}$$

18.

Using Eqs. (4.39) and (4.34) to find  $\zeta = 0.5169$  and  $\omega_n = 18.3498$  respectively. Factoring the denominator of Eq. (4.22), the required poles are  $-9.4856 \pm j15.708$ . We place the third pole 10 times further at  $-94.856$ . Multiplying the three closed-loop pole terms yields the desired characteristic equation:  $s^3 + 114s^2 + 2136s + 31940 = 0$ . Representing the plant in parallel form:

$$\mathbf{A}_{\text{par}} = \begin{bmatrix} 0 & 0 & 0 \\ 0 & -5 & 0 \\ 0 & 0 & -9 \end{bmatrix}; \mathbf{B}_{\text{par}} = \begin{bmatrix} 2.222 \\ -5 \\ 2.778 \end{bmatrix}; \mathbf{C}_{\text{par}} = [1 \quad 1 \quad 1]. \text{ Using Eq. (12.26),}$$

$$\mathbf{C}_{\text{Mpar}} = \begin{bmatrix} 2.222 & 0 & 0 \\ -5 & 25 & -125 \\ 2.778 & -25 & 225.018 \end{bmatrix}, \text{ which is controllable since the determinant is } 5555.4. \text{ Since}$$

$$G(s) = \frac{100}{s^3 + 14s^2 + 45s}, \text{ the controller canonical form is } \mathbf{A}_{\text{cc}} = \begin{bmatrix} -14 & -45 & 0 \\ 1 & 0 & 0 \\ 0 & 1 & 0 \end{bmatrix}; \mathbf{B}_{\text{cc}} = \begin{bmatrix} 1 \\ 0 \\ 0 \end{bmatrix};$$

$$\mathbf{C} = [0 \quad 0 \quad 100]. \text{ Using Eq. (12.26), } \mathbf{C}_{\text{Mcc}} = \begin{bmatrix} 1 & -14 & 151 \\ 0 & 1 & -14 \\ 0 & 0 & 1 \end{bmatrix}, \text{ which is controllable since the}$$

determinant is 1. The first row of  $\mathbf{A}_{\text{cc}}$  contains the coefficients of the characteristic equation.

Comparing the first row of  $\mathbf{A}_{\text{cc}}$  to the desired characteristic equation and using the results of Problem 5,  $(14 + k_1) = 114$ ;  $(45 + k_2) = 2136$ ; and  $(0 + k_3) = 31940$ . Hence  $\mathbf{K}_{\text{cc}} = [31940 \quad 2091 \quad 110]$ . The

$$\text{transformation matrix is, } \mathbf{P} = \mathbf{C}_{\text{Mpar}}\mathbf{C}_{\text{Mcc}}^{-1} = \begin{bmatrix} 2.222 & 31.108 & 99.99 \\ -5 & -45 & 0 \\ 2.778 & 13.89 & 0 \end{bmatrix}. \text{ Transforming back to}$$

the original system,  $\mathbf{K}_{\text{par}} = \mathbf{K}_{\text{cc}}\mathbf{P}^{-1} = [1.1 \quad 7882 \quad 25682]$ .

19.

a.

```
>> A=[-0.014 0 -1.4 0 0; 0.023 -0.023 -0.023 0 0; 0.134 0.67 -0.67 0.38 0.003264; 0 0 0.06 -0.06 0;
0 0 0.0017 0 -0.001];
```

```
>> B = [1;0;0;0;0];
```

```
>> rank(ctrb(A,B))
```

```
ans =
```

```
5
```

The controllability matrix has full rank so the system is controllable.

b.

```
>> [P,Ad]=jordan(A) % P is the similarity transformation matrix used for diagonalization, Ad the
diagonalized A matrix
```

```
P =
```

```
-0.0000 + 0.0000i  1.3181 + 0.1838i  0.0446      -1.6808      1.3181 - 0.1838i
-0.0000 + 0.0000i -0.0336 - 0.0948i -0.0286      0.0958      -0.0336 + 0.0948i
0.0000 - 0.0000i  0.1916 - 0.1798i  0.0014      -0.3845      0.1916 + 0.1798i
0.0000 - 0.0000i -0.0605 - 0.0176i  0.0370      0.0841      -0.0605 + 0.0176i
0.0012 - 0.0000i -0.0016 - 0.0002i -0.0000      0.0020      -0.0016 + 0.0002i
```

Ad =

$$\begin{bmatrix} -0.0010 & 0 & 0 & 0 & 0 \\ 0 & -0.1875 + 0.2151i & 0 & 0 & 0 \\ 0 & 0 & -0.0577 & 0 & 0 \\ 0 & 0 & 0 & -0.3343 & 0 \\ 0 & 0 & 0 & 0 & -0.1875 - 0.2151i \end{bmatrix}$$

>> Bd=inv(P)\*B

Bd =

$$\begin{bmatrix} 1.0000 + 0.0000i \\ 1.0000 \\ 1.0000 + 0.0000i \\ 1.0000 + 0.0000i \\ 1.0000 + 0.0000i \end{bmatrix}$$

20.

$$G(s) = \frac{1}{s(s+3)(s+7)} = \frac{1}{s^3 + 10s^2 + 21s + 0}$$

Writing the **A** and **C** matrices for the observer canonical system,

$$\begin{array}{ccc} \mathbf{Az} & & \\ -10 & 1 & 0 \\ -21 & 0 & 1 \\ 0 & 0 & 0 \\ \mathbf{Cz} & & \\ 1 & 0 & 0 \end{array}$$

The characteristic polynomial is  $s^3 + 10s^2 + 21s + 0$ .

Now check observability by calculating the observability matrix and its determinant.

<b>OMz</b>	Observability Matrix of z	
1	0	0
-10	1	0
79	-10	1
<b>Det(OMz)</b>	1	

Using the given transient requirements, and placing the third closed-loop pole 10 times further from the imaginary axis than the dominant poles yields the following desired characteristic polynomial:

$$(s + 300)(s^2 + 60s + 5625) = s^3 + 360s^2 + 23625s + 1687500$$

Equating this polynomial to Eq. (12.67), yields the observer gains as:

<b>Lz</b>	Observer for z
350	
23604	
1687500	

**21.**

Using Eqs. (4.39) and (4.34) to find  $\zeta = 0.5912$  and  $\omega_n = 19.4753$  respectively. Factoring the denominator of Eq. (4.22), the required poles are  $-11.513 \pm j15.708$ . We place the third pole 20 times further at  $-230.26$ . Multiplying the three closed-loop pole terms yields the desired characteristic equation:  $s^3 + 253.28s^2 + 5681.19s + 87334.19 = 0$ .

Representing the plant in observer canonical form:  $\mathbf{A}_{oc} = \begin{bmatrix} -25 & 1 & 0 \\ -171 & 0 & 1 \\ -315 & 0 & 0 \end{bmatrix}$ ;  $\mathbf{B}_{oc} = \begin{bmatrix} 0 \\ 0 \\ 10 \end{bmatrix}$ ;

$\mathbf{C}_{oc} = [1 \ 0 \ 0]$ . The first column of  $\mathbf{A}_{oc}$  contains the coefficients of the characteristic equation.

Comparing the first column of  $\mathbf{A}_{oc}$  to the desired characteristic equation and using Eq. (12.67),  $l_1 = 253.28 - 25 = 228.28$ ;  $l_2 = 5681.19 - 171 = 5510.19$ ; and  $l_3 = 87334.19 - 315 = 87019.19$ . Hence,

$$\mathbf{L}_{oc} = [228.28 \ 5510.19 \ 87019.19]^T.$$

**22.**

The  $\mathbf{A}$ ,  $\mathbf{L}$ , and  $\mathbf{C}$  matrices for the phase-variable system are:

$$\mathbf{A} = \begin{bmatrix} 0 & 1 & 0 \\ 0 & 0 & 1 \\ 0 & -21 & -10 \end{bmatrix}$$

$$\mathbf{C} = [1 \ 0 \ 0]$$



$$\mathbf{L} = \begin{bmatrix} l_1 \\ l_2 \\ l_3 \end{bmatrix}$$

Hence,

$$|\lambda - (\mathbf{A} - \mathbf{LC})| = \begin{vmatrix} \lambda + l_1 & -1 & 0 \\ l_2 & \lambda & -1 \\ l_3 & 21 & \lambda + 10 \end{vmatrix}$$

or

$$|\lambda - (\mathbf{A} - \mathbf{LC})| = \lambda^3 + (10 + l_1)\lambda^2 + (21 + 10l_1 + l_2)\lambda + (21l_1 + 10l_2 + l_3)$$

From Problem 19, the desired characteristic polynomial is  $\lambda^3 + 360\lambda^2 + 23625\lambda + 1687500$ .

Equating coefficients yields:

$$10 + l_1 = 360; (21 + 10l_1 + l_2) = 23625; (21l_1 + 10l_2 + l_3) = 1687500$$

Solving successively,

$$l_1 = 350; l_2 = 20104; l_3 = 1479110$$

23.

The  $\mathbf{A}$ ,  $\mathbf{L}$ , and  $\mathbf{C}$  matrices for the phase-variable system are:

$$\mathbf{A} = \begin{bmatrix} 0 & 1 \\ -45 & -14 \end{bmatrix}; \mathbf{C} = [2 \quad 1]; \mathbf{L} = \begin{bmatrix} l_1 \\ l_2 \end{bmatrix}$$

Hence,

$$|\lambda - (\mathbf{A} - \mathbf{LC})| = \begin{vmatrix} \lambda + 2l_1 & l_1 - 1 \\ 2l_2 + 45 & l_2 + \lambda + 14 \end{vmatrix}$$

or

$$\lambda^2 + (2l_1 + l_2 + 14)\lambda + (2l_2 - 17l_1 + 45)$$

From the problem statement, the desired characteristic polynomial is  $\lambda^2 + 144\lambda + 14400$ .

Equating coefficients yields,

$$(2l_1 + l_2 + 14) = 144; (2l_2 - 17l_1 + 45) = 14400$$

Solving simultaneously,

$$l_1 = -671.2; l_2 = 1472.4$$

24.

The  $\mathbf{A}$  matrix for each part is given in the solution to Problem 11. Each observability matrix is calculated from Eq. (12.79).

a.

$$\mathbf{A} = \begin{pmatrix} -2 & 0 & 1 \\ 0 & -2 & 0 \\ 0 & 0 & -3 \end{pmatrix}; \mathbf{C} = (5, 5, 5); \mathbf{OM} = \begin{pmatrix} 5 & 5 & 5 \\ -10 & -10 & -10 \\ 20 & 20 & 20 \end{pmatrix}; |\mathbf{OM}| = 0; \text{unobservable}$$

b.

$$A = \begin{pmatrix} -2 & 1 & 0 \\ 0 & -2 & 0 \\ 0 & 0 & -3 \end{pmatrix}; C = (5, 0, 5); O_M = \begin{pmatrix} 5 & 0 & 5 \\ -10 & 5 & -15 \\ 20 & -20 & 45 \end{pmatrix}; |O_M| = 125; \text{ observable}$$

c.

$$A = \begin{pmatrix} -4 & 1 & 0 \\ 0 & 0 & 1 \\ 0 & 0 & -3 \end{pmatrix}; C = (1, 0, 0); O_M = \begin{pmatrix} 1 & 0 & 0 \\ -4 & 1 & 0 \\ 16 & -4 & 1 \end{pmatrix}; |O_M| = 1; \text{ observable}$$

d.

$$A = \begin{pmatrix} -4 & 1 & 0 \\ 0 & 0 & 1 \\ -5 & 0 & -3 \end{pmatrix}; C = (1, 0, 0); O_M = \begin{pmatrix} 1 & 0 & 0 \\ -4 & 1 & 0 \\ 16 & -4 & 1 \end{pmatrix}; |O_M| = 1; \text{ observable}$$

e.

$$A = \begin{pmatrix} 0 & 1 \\ -6 & -5 \end{pmatrix}; C = (1, 0); O_M = \begin{pmatrix} 1 & 0 \\ 0 & 1 \end{pmatrix}; |O_M| = 1; \text{ observable}$$

f.

$$A = \begin{pmatrix} -4 & 0 & 0 \\ 0 & -5 & 0 \\ 0 & 0 & -6 \end{pmatrix}; C = (1, 1, 1); O_M = \begin{pmatrix} 1 & 1 & 1 \\ -4 & -5 & -6 \\ 16 & 25 & 36 \end{pmatrix}; |O_M| = -2; \text{ observable}$$

25.

**Program:**

```
'(a)'  
A=[-2 0 1;0 -2 0;0 0 -3]           %Form compensated A matrix  
C=[5 5 5]                         %Form compensated C matrix  
Om=obsv(A,C)                       %Form observability matrix  
Rank=rank(Om)                      %Find rank of observability  
                                     %matrix  
  
'(f)'  
A=[-4 0 0;0 -5 0;0 0 -6]         %Form compensated A matrix  
C=[1 1 1]                         %Form compensated C matrix  
Om=obsv(A,C)                       %Form observability matrix  
Rank=rank(Om)                      %Find rank of observability
```

**Computer response:**

ans =

(a)

A =

```
   -2     0     1  
     0    -2     0  
     0     0    -3
```

C =

```
     5     5     5
```

Om =

```
     5     5     5  
    -10   -10   -10  
     20     20     20
```

Rank =

1

ans =

(f)

A =

$$\begin{bmatrix} -4 & 0 & 0 \\ 0 & -5 & 0 \\ 0 & 0 & -6 \end{bmatrix}$$

C =

$$\begin{bmatrix} 1 & 1 & 1 \end{bmatrix}$$

Om =

$$\begin{bmatrix} 1 & 1 & 1 \\ -4 & -5 & -6 \\ 16 & 25 & 36 \end{bmatrix}$$

Rank =

3

26.

Representing the system in state space yields

$$\dot{\mathbf{x}} = \begin{bmatrix} 0 & 1 \\ -1 & -2 \end{bmatrix} \mathbf{x} + \begin{bmatrix} 0 \\ 1 \end{bmatrix} u ; y = \begin{bmatrix} c_1 & c_2 \end{bmatrix} \mathbf{x}$$

Using Eq. (12.79),

$$\mathbf{O}_M = \begin{bmatrix} c_1 & c_2 \\ -c_2 & (c_1 - 2c_2) \end{bmatrix} \text{ and } \det \mathbf{O}_M = c_1^2 - 2c_1c_2 + c_2^2$$

Thus, the system is unobservable if  $c_1 = c_2$ .

27.

The **A** and **C** matrices for the system represented in cascade form is

$$\begin{array}{ccc} \mathbf{Az} & & \\ -20 & 1 & 0 \\ 0 & -13 & 1 \\ 0 & 0 & -5 \\ \mathbf{Cz} & & \\ 1 & 0 & 0 \end{array}$$

The characteristic polynomial found from the transfer function of the plant is

$$s^3 + 38s^2 + 425s + 1300$$

From this characteristic polynomial, we can write observer canonical form of the state equations. The **A** and **C** matrices of the observer canonical form are given below as

$$\begin{array}{ccc} \mathbf{Ax} & & \\ -38 & 1 & 0 \\ -425 & 0 & 1 \\ -1300 & 0 & 0 \\ \mathbf{Cx} & & \\ 1 & 0 & 0 \end{array}$$

To test observability, we write the observability matrices for both systems and show that both observability matrices have non zero determinants. Using Eq. (12.79),

<b>OMz</b>	Observability Matrix of z			<b>OMx</b>	Observability Matrix of x		
1	0	0		1	0	0	
-20	1	0		-38	1	0	
400	-33	1		1019	-38	1	
<b>Det(OMz)</b>	1			<b>Det(OMx)</b>	1		

Using Eq. (12.89), we obtain the transformation matrix, **P**, and its inverse as

<b>P</b>	Transformation Matrix z=Px			<b>PINV</b>			
1	0	0		1.00	0.00	0.00	
-18	1	0		18.00	1.00	0.00	
25	-5	1		65.00	5.00	1.00	

Using the characteristic polynomial given in the problem statement, the plant's characteristic equation, and Eq. (12.67), the observer for the observer canonical system is

$$\mathbf{Lx} \quad \text{Observer for x}$$

$$\begin{array}{r} 562 \\ 39575 \\ 1498700 \end{array}$$

Using Eq. (12.92), the observer for the cascade system is found to be

$$\mathbf{Lz} \quad \text{Observer for z}$$

$$\begin{array}{r} 562 \\ 29459 \\ 1314875 \end{array}$$

28.

**Program:**

```
A=[-20 1 0;0 -13 1;0 0 -5]
B=[0;0;1]
C=[1 0 0]
D=0
poles=roots([1 600 40000 1500000])
L=acker(A',C',poles);
'L'
L'
```

**Computer response:**

A =

$$\begin{array}{ccc} -20 & 1 & 0 \\ 0 & -13 & 1 \\ 0 & 0 & -5 \end{array}$$

B =

$$\begin{array}{c} 0 \\ 0 \end{array}$$

```

      1
C =
      1      0      0

D =
      0

poles =
      1.0e+002 *
      -5.2985
      -0.3508 + 0.4001i
      -0.3508 - 0.4001i

ans =

L

ans =
      1.0e+006 *
      0.0006
      0.0295
      1.3149

```

29.

Expanding the plant by partial fractions, we obtain

$$G(s) = \frac{1}{(s+5)(s+13)(s+20)} = \frac{0.008333}{(s+5)} - \frac{0.017857}{(s+13)} + \frac{0.0095238}{(s+20)}$$

The **A** and **C** matrices for the system represented in parallel form is

$$\begin{array}{ccc} \mathbf{Az} & & \\ -5 & 0 & 0 \\ 0 & -13 & 0 \\ 0 & 0 & -20 \\ \mathbf{Cz} & & \\ 1 & 1 & 1 \end{array}$$

The characteristic polynomial found from the transfer function of the plant is

$$s^3 + 38s^2 + 425s + 1300$$

From this characteristic polynomial, we can write the observer canonical form of the state equations.

The **A** and **C** matrices of the observer canonical form are given below as

$$\mathbf{Ax} \begin{array}{ccc} -38 & 1 & 0 \\ -425 & 0 & 1 \\ -1300 & 0 & 0 \end{array}$$

$$\mathbf{Cx} \begin{array}{ccc} 1 & 0 & 0 \end{array}$$

To test observability, we write the observability matrices for both systems and show that both observability matrices have non zero determinants. Using Eq. (12.79),

<b>OMz</b>	Observability Matrix of z			<b>OMx</b>	Observability Matrix of x		
1	1		1	1	0		0
-5	-13		-20	-38	1		0
25	169		400	1019	-38		1
<b>Det(OMz)</b>	-840			<b>Det(OMx)</b>	1		

Using Eq. (12.89), we obtain the transformation matrix,  $\mathbf{P}$ , and its inverse as

<b>P</b>	Transformation Matrix $z=Px$			<b>PINV</b>			
0.2083333	-0.04166667		0.008333333	1.00	1.00		1.00
-3.017857	0.232142857		-0.01785714	33.00	25.00		18.00
3.8095238	-0.19047619		0.00952381	260.00	100.00		65.00

Using the characteristic polynomial given in the problem statement, the plant's characteristic equation, and Eq. (12.67), the observer for the observer canonical system is

$$\mathbf{Lx} \quad \text{Observer for x} \begin{array}{c} 562 \\ 39575 \\ 1498700 \end{array}$$

Using Eq. (12.92), the observer for the parallel system is found to be

$$\mathbf{Lz} \quad \text{Observer for z} \begin{array}{c} 10957.29167 \\ -19271.4821 \\ 8876.190476 \end{array}$$

30.

Use Eqs. (4.39) and (4.42) to find  $\zeta = 0.5912$  and  $\omega_n = 135.328$  respectively. Factoring the denominator of Eq. (4.22), the required poles are  $-80 \pm j109.15$ . We place the third pole 10 times further at  $-800$ . Multiplying the three closed-loop pole terms yields the desired characteristic equation:

$$s^3 + 960s^2 + 146313.746s + 14650996.915 = 0.$$

Since  $G(s) = \frac{50}{s^3 + 18s^2 + 99s + 162}$ , the plant in observer canonical form is:  $\mathbf{A}_{oc} = \begin{bmatrix} -18 & 1 & 0 \\ -99 & 0 & 1 \\ -162 & 0 & 0 \end{bmatrix}$ ;

$\mathbf{B}_{oc} = \begin{bmatrix} 0 \\ 0 \\ 50 \end{bmatrix}$ ;  $\mathbf{C}_{oc} = [1 \ 0 \ 0]$ . Using Eq. (12.79),  $\mathbf{O}_{Moc} = \begin{bmatrix} 1 & 0 & 0 \\ -18 & 1 & 0 \\ 225 & -18 & 1 \end{bmatrix}$ , which is observable since

the determinant is 1. Since  $G(s) = \frac{50}{s^3 + 18s^2 + 99s + 162}$ , the phase-variable form is

$\mathbf{A}_{pv} = \begin{bmatrix} 0 & 1 & 0 \\ 0 & 0 & 1 \\ -162 & -99 & -18 \end{bmatrix}$ ;  $\mathbf{B}_{pv} = \begin{bmatrix} 0 \\ 0 \\ 1 \end{bmatrix}$ ;  $\mathbf{C} = [50 \ 0 \ 0]$ . Using Eq. (12.79),

$\mathbf{O}_{Mpv} = \begin{bmatrix} 50 & 0 & 0 \\ 0 & 50 & 0 \\ 0 & 0 & 50 \end{bmatrix}$ , which is observable since the determinant is 125000. The first column of

$\mathbf{A}_{oc}$  contains the negatives values of the coefficients of the characteristic equation. Comparing the first column of  $\mathbf{A}_{oc}$  to the desired characteristic equation and using Eq. (12.67),  $l_1 = 960 - 18 = 942$ ;  $l_2 = 146313.746 - 99 = 146214.746$ ; and  $l_3 = 14650996.915 - 162 = 14650834.915$ . Hence,

$\mathbf{L}_{oc} = [942 \ 146214.746 \ 14650834.915]$ . The transformation matrix is,

$$\mathbf{P} = \mathbf{O}_{Mpv}^{-1} \mathbf{O}_{Moc} = \begin{bmatrix} 0.02 & 0 & 0 \\ -0.36 & 0.02 & 0 \\ 4.5 & -0.36 & 0.02 \end{bmatrix}$$

Transforming back to the original system,  $\mathbf{L}_{pv} = \mathbf{P} \mathbf{L}_{oc} = [18.84 \ 2585.175 \ 244618.39]^T$ .

31.

a.

Since both systems are in phase variable form it readily follows that:

$$\det(s\mathbf{I} - \mathbf{A}_1) = s^2 + 3s + 2$$

and

$$\det(s\mathbf{I} - \mathbf{A}_2) = s^3 + 6s^2 + 11s + 6$$

$$G_1(s) = \mathbf{C}_1(s\mathbf{I} - \mathbf{A}_1)^{-1}\mathbf{B}_1 = [2 \quad 0] \frac{\begin{bmatrix} s+3 & 1 \\ -2 & s \end{bmatrix}}{s^2 + 3s + 2} \begin{bmatrix} 0 \\ 1 \end{bmatrix} = \frac{2}{s^2 + 3s + 2}$$

$$G_2(s) = \mathbf{C}_2(s\mathbf{I} - \mathbf{A}_2)^{-1}\mathbf{B}_2 = [6 \quad 2 \quad 0] \frac{\begin{bmatrix} s^2 + 6s + 11 & s + 6 & 1 \\ -6 & s(s+6) & s \\ -6s & -(11s+6) & s^2 \end{bmatrix}}{s^3 + 6s^2 + 11s + 6} \begin{bmatrix} 0 \\ 0 \\ 1 \end{bmatrix}$$

$$= \frac{2(s+3)}{s^3 + 6s^2 + 11s + 6} = \frac{2}{s^2 + 3s + 2}$$

b.

$$\mathbf{O}_{M1} = \begin{bmatrix} \mathbf{C}_1 \\ \mathbf{C}_1\mathbf{A}_1 \end{bmatrix} = \begin{bmatrix} 2 & 0 \\ 0 & 2 \end{bmatrix}; \text{rank}(\mathbf{O}_{M1}) = 2 \text{ System 1 is observable}$$

$$\mathbf{O}_{M2} = \begin{bmatrix} \mathbf{C}_2 \\ \mathbf{C}_2\mathbf{A}_2 \\ \mathbf{C}_2\mathbf{A}_2^2 \end{bmatrix} = \begin{bmatrix} 6 & 2 & 0 \\ 0 & 6 & 2 \\ -12 & -22 & -6 \end{bmatrix}; \text{rank}(\mathbf{O}_{M2}) = 2 \text{ System 2 is not observable}$$

32.

The open-loop transfer function of the plant is  $T(s) = \mathbf{C}(s\mathbf{I} - \mathbf{A})^{-1}\mathbf{B} = \frac{s+2}{s^2-s-2}$ .

Using Eqs. (12.115), the closed-loop state equations with integral control is

$$\begin{pmatrix} \dot{x}_1 \\ \dot{x}_2 \\ \dot{x}_N \end{pmatrix} = \begin{pmatrix} -1 & 1 & 0 \\ -k_1 & -k_2 + 2 & k_e \\ -1 & -1 & 0 \end{pmatrix} \begin{pmatrix} x_1 \\ x_2 \\ x_N \end{pmatrix} + \begin{pmatrix} 0 \\ 0 \\ 1 \end{pmatrix} r; \quad y = (1, 1, 0) \begin{pmatrix} x_1 \\ x_2 \\ x_N \end{pmatrix}$$

The characteristic polynomial is

$$s^3 + (k_2 - 1)s^2 + (k_2 + k_1 + k_e - 2)s + 2k_e$$

The desired characteristic polynomial is calculated from the desired transient response stated in the problem. Also, the third pole will be placed to cancel the zero at -2. Hence, the desired characteristic polynomial is

$$(s + 2)(s^2 + 16s + 183.137) = s^3 + 18s^2 + 215.14s + 366.27$$

Equating coefficients of the characteristic polynomials yields,

$$k_e = 183.135, k_2 = 19, k_1 = 15.005$$



33.

The open-loop transfer function of the plant is  $T(s) = \mathbf{C}(s\mathbf{I}-\mathbf{A})^{-1}\mathbf{B} = \frac{s+3}{s^2+7s+10}$ .

Using Eqs. (12.115), the closed-loop state equations with integral control is

$$\begin{pmatrix} \dot{x}_1 \\ \dot{x}_2 \\ \dot{x}_N \end{pmatrix} = \begin{pmatrix} -2 & 1 & 0 \\ -k_1 & -(5+k_2) & k_e \\ -1 & -1 & 0 \end{pmatrix} \begin{pmatrix} x_1 \\ x_2 \\ x_N \end{pmatrix} + \begin{pmatrix} 0 \\ 0 \\ 1 \end{pmatrix} r \quad ; \quad y = (1, 1, 0) \begin{pmatrix} x_1 \\ x_2 \\ x_N \end{pmatrix}$$

The characteristic polynomial is

$$s^3 + (k_2 + 7)s^2 + (2k_2 + k_1 + k_e + 10)s + 3k_e$$

The desired characteristic polynomial is calculated from the desired transient response stated in the problem. Also, the third pole will be placed to cancel the zero at -3. Hence, the desired characteristic polynomial is

$$(s+3)(s^2 + 16s + 183.14) = s^3 + 19s^2 + 231.14s + 549.41$$

Equating coefficients of the characteristic polynomials yields,

$$k_e = 183.137, k_2 = 12, k_1 = 14.003$$

## SOLUTIONS TO DESIGN PROBLEMS

34.

Writing the **A** and **B** matrices for  $(G(s))$  represented in phase-variables form,

<b>A</b>			<b>B</b>
0	1	0	0
0	0	1	0
1.30E+06	4551	-286	10

From the phase-variable form, the characteristic polynomial is  $s^3 + 286s^2 - 4551s - 1301586$ .

Finding the controllability matrix and its determinant shows that there is controllability,

<b>CM</b>			
0	0	10	
0	10	-2860	
10	-2860	863470	
<b>Det(CM)</b>	-1000		

Using the given transient requirements, and arbitrarily placing the third closed-loop pole more than 5 times further than the dominant pair at -50 yields the following desired closed-loop characteristic polynomial:

$(s^2 + 16s + 134.384)(s + 50) = s^3 + 66s^2 + 934.4s + 6719.2$  Using the phase-variable system with state feedback the characteristic polynomial is

$$s^3 + (k_3 + 286)s^2 + (k_2 - 4551)s + (k_1 - 1301586)$$

Equating the two characteristic polynomials yields the state feedback vector for the phase-variable system as

$$\mathbf{K} \begin{matrix} 1308305.2 & 5485.4 & -220 \end{matrix}$$

35.

a. The open loop characteristic polynomial is

$$(s + 0.004)(s + 0.19)(s + 0.66) = s^3 + 0.854s^2 + 0.1288s + 0.0005016 = s^3 + a_2s^2 + a_1s + a_0$$

The desired characteristic polynomial is

$$\left(s + \frac{1}{15}\right)^2(s + 0.5) = s^3 + 0.854s^2 + 0.1288s + 0.0005016 = s^3 + d_2s^2 + d_1s + d_0$$

So we have

$$k_1 = d_0 - a_0 = 0.0017204$$

$$k_2 = d_1 - a_1 = -0.05769$$

$$k_3 = d_2 - a_2 = -0.2207$$

b.

$$\gg \mathbf{A} = [0 \ 1 \ 0; 0 \ 0 \ 1; -0.0005016 \ -0.1288 \ -0.854];$$

$$\gg \mathbf{B} = [0; 0; 1];$$

$$\gg \mathbf{C} = [0.000078 \ 0.00414 \ 0.01];$$

$$\gg \mathbf{K} = [0.0017204 \ -0.05769 \ -0.2207];$$

$$\gg \text{eig}(\mathbf{A} - \mathbf{B} * \mathbf{K})$$

ans =

$$-0.49995739538301$$

$$-0.06584435043216$$

$$-0.06749825418482$$

36.

a. By inspection the phase variable form of this system results in

$$A = \begin{bmatrix} 0 & 1 & 0 \\ 0 & 0 & 1 \\ -0.000078 & -0.01265 & -0.5250 \end{bmatrix}; B = \begin{bmatrix} 0 \\ 0 \\ 1 \end{bmatrix};$$

$$C = [-0.01197 \times 10^{-4} \quad -0.958 \times 10^{-4} \quad 0]; D = 0$$

b. The characteristic equation of the closed loop system will have 3 poles. Two of them will be placed at  $-\frac{4}{300 \text{sec}} = \frac{1}{75} \text{sec}^{-1}$  to satisfy the settling time spec. The third pole will be placed farther to the left of the latter, say at -0.05. The desired characteristic polynomial is  $(s + 0.0133)^2(s + 0.05) = s^3 + 0.0766s^2 + 0.00150689s + 0.0000088445 = 0$

The closed loop matrix is

$$A - BK = \begin{bmatrix} 0 & 1 & 0 \\ 0 & 0 & 1 \\ -(0.000078 + k_1) & -(0.01265 + k_2) & -(0.525 + k_3) \end{bmatrix}$$

Which will result in a characteristic polynomial

$$s^3 + (0.525 + k_3)s^2 + (0.01265 + k_2)s + (0.000078 + k_1) = 0$$

Equating coefficients for both polynomials we get  $k_3 = -0.4484$ ,  $k_2 = -0.01114311$  and

$$k_1 = -6.91555 \times 10^{-5}$$

c.

```
>> A=[0 1 0; 0 0 1; -0.000078 -0.01265 -0.525];
```

```
>> B=[0;0;1];
```

```
>> C=[-0.01197e-4 -0.9580e-4 0];
```

```
>> D=0;
```

```
>> K=[-6.91555e-5 -0.01114311 -0.4484];
```

```
>> eig(A-B*K) %check
```

```
ans =
```

-0.0133

-0.0133

-0.0500

&gt;&gt; step(A-B\*K,B,C,D)

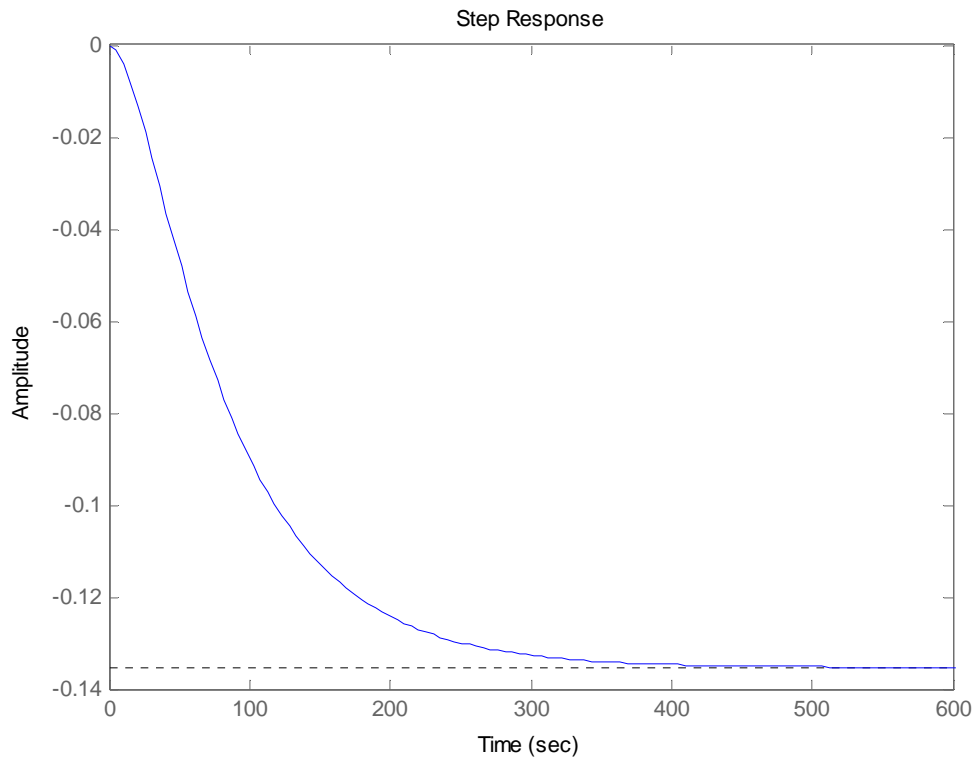

37.

a. The system's transfer function  $G(s) = \mathbf{C}(s\mathbf{I} - \mathbf{A})^{-1}\mathbf{B} = \frac{83335}{s^2 + 10s + 41665}$

b. From the transfer function by inspection

$$A_p = \begin{bmatrix} 0 & 1 \\ -41665 & -10 \end{bmatrix}; B_p = \begin{bmatrix} 0 \\ 1 \end{bmatrix}; C_p = [83335 \quad 0]$$

c. A 20% overshoot gives  $\zeta = 0.7$ , and  $\omega_n = \frac{4}{\zeta T_s} = 11.43$  so the desired characteristic equation is  $s^2 + 2\zeta\omega_n s + \omega_n^2 = s^2 + 16s + 130.65$

Equating gains we have

$$41665 + k_1 = 130.65 \text{ and } 10 + k_2 = 16 \text{ giving } K_x = [k_1 \quad k_2] = [-41534.35 \quad 6]$$

d. The Controllability matrix for the original system is

$$\mathbf{C}_{Mz} = [\mathbf{B} \quad \mathbf{AB}] = \begin{bmatrix} 167 & 0 \\ 0 & 83335 \end{bmatrix}$$

The Controllability matrix for the phase variable system is

$$\mathbf{C}_{Mx} = [\mathbf{B}_p \quad \mathbf{A}_p \mathbf{B}_p] = \begin{bmatrix} 0 & 1 \\ 1 & -10 \end{bmatrix}$$

The transformation matrix is

$$\mathbf{P} = \mathbf{C}_{Mz} \mathbf{C}_{Mx}^{-1} = \begin{bmatrix} 1667 & 167 \\ 83335 & 0 \end{bmatrix}$$

The set of gains for the original system is:

$$\mathbf{K}_z = \mathbf{K}_x \mathbf{P}^{-1} = [0.0360 \quad -0.4991]$$

e.  $\det(sI - (A - BK_z)) = s^2 + 16s + 130.65$

f.

```
>> A=[0 -83.33; 500 -10];
```

```
>> B = [166.67;0];
```

```
>> C=[0 1];
```

```
>> K=[0.0360 -0.499];
```

```
>> step(A-B*K,B,C,0)
```

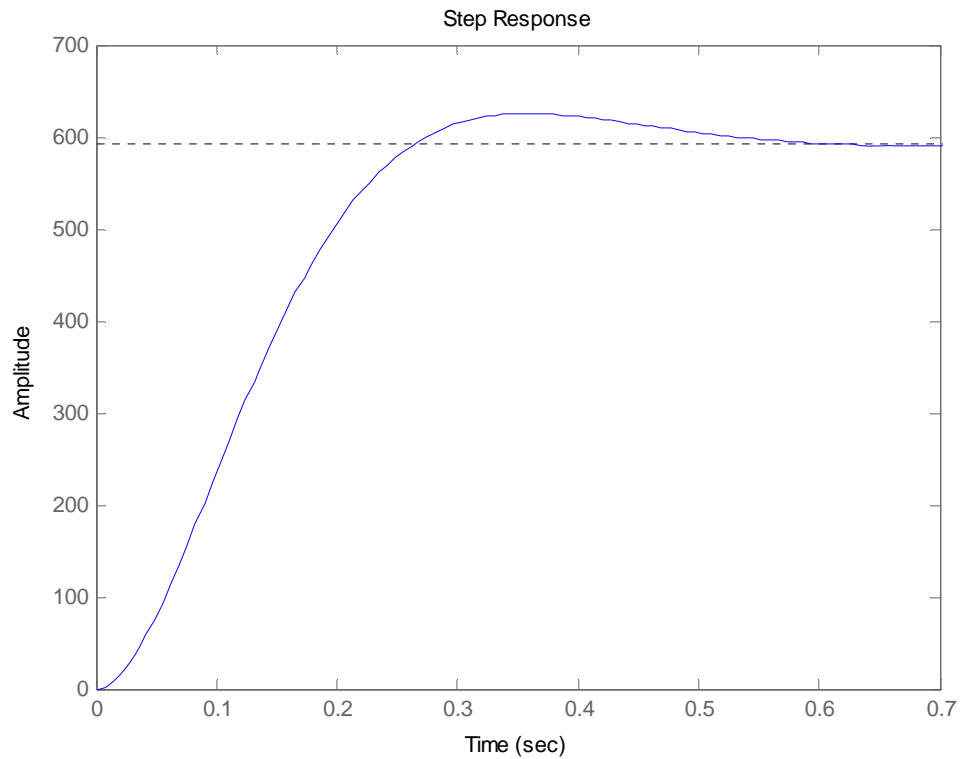

38.

a. We start by expressing the system in Observable Canonical form. From problem IV, the transfer

$$\text{function is } G(s) = \frac{C(s)}{R(s)} = \frac{83335}{s^2 + 10s + 41665} = \frac{\frac{83335}{s^2}}{1 + \frac{10}{s} + \frac{41665}{s^2}}, \text{ so we can write}$$

$$C(s) = \frac{1}{s} \left( -10C(s) + \frac{1}{s} (83335R(s) - 41665C(s)) \right) \text{ from which we get the following}$$

diagram:

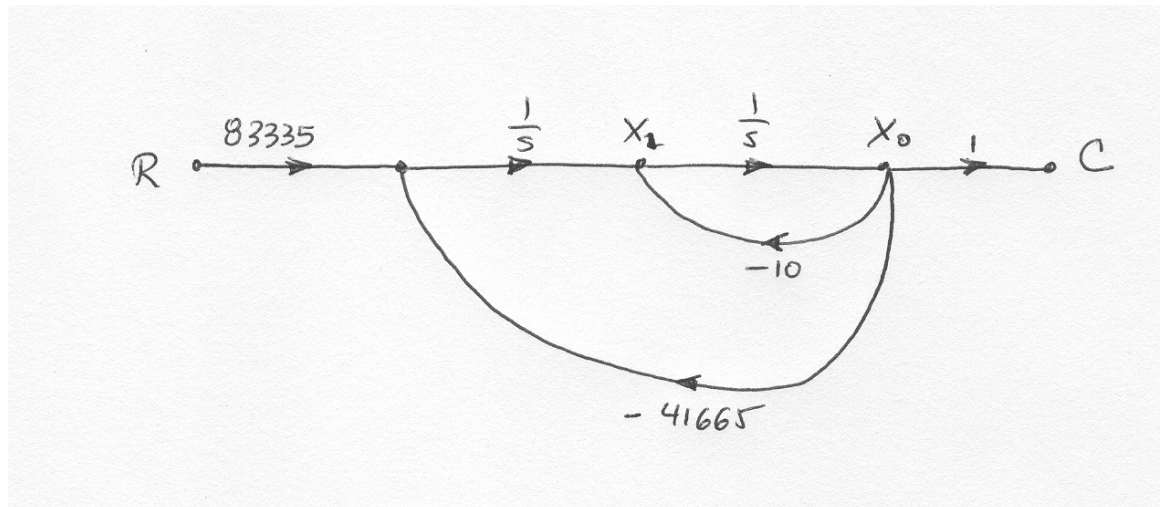

By direct inspection we can write

$$\begin{bmatrix} \dot{x}_0 \\ \dot{x}_1 \end{bmatrix} = \begin{bmatrix} -10 & 1 \\ -41665 & 0 \end{bmatrix} \begin{bmatrix} x_0 \\ x_1 \end{bmatrix} + \begin{bmatrix} 0 \\ 83335 \end{bmatrix} E_s \text{ and } y = [1 \quad 0] \begin{bmatrix} x_0 \\ x_1 \end{bmatrix}$$

The characteristic equation for this system is  $s^2 + 10s + 41665 = 0$  with roots at  $-5 \pm j204.06$ . To make the observer 10 times faster its poles will be placed at  $-50 \pm j2040.6$

The desired characteristic equation is  $s^2 + 100s + 4.167 \times 10^6 = 0$

The error equation is given by

$$\dot{\mathbf{e}}_x = (\mathbf{A} - \mathbf{LC})\mathbf{e}_x = \begin{bmatrix} -(10 + l_1) & 1 \\ -(41665 + l_2) & 0 \end{bmatrix} \mathbf{e}_x \text{ which has a characteristic equation}$$

$$s^2 + (10 + l_1)s + (41665 + l_2) = 0$$

By equating coefficients with the desired characteristic equation we obtain

$$l_1 = 100 - 10 = 90 \text{ and } l_2 = 4.167 \times 10^6 - 41665 = 4125335$$

b.

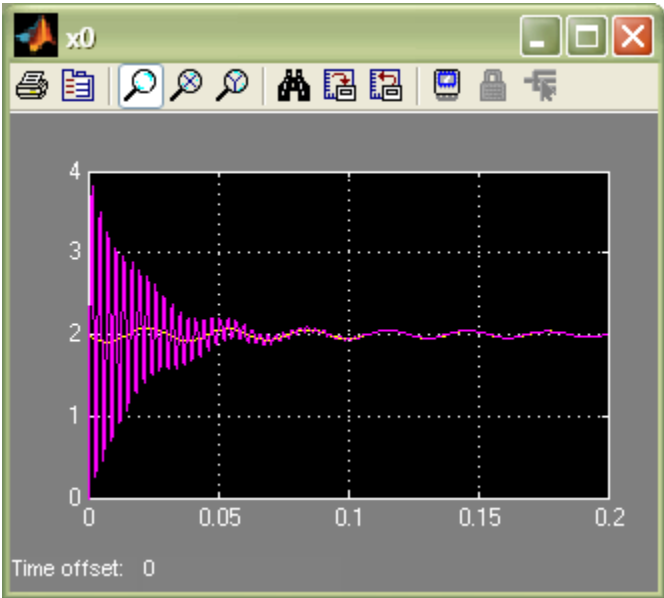
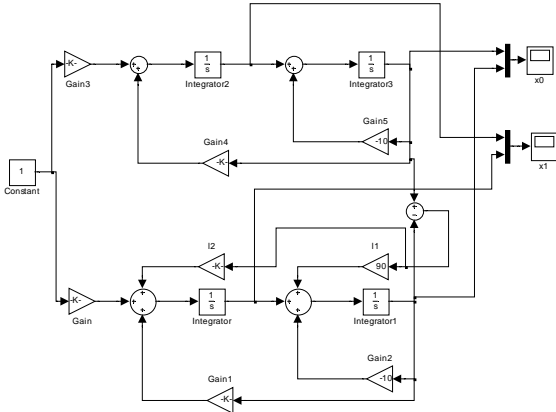



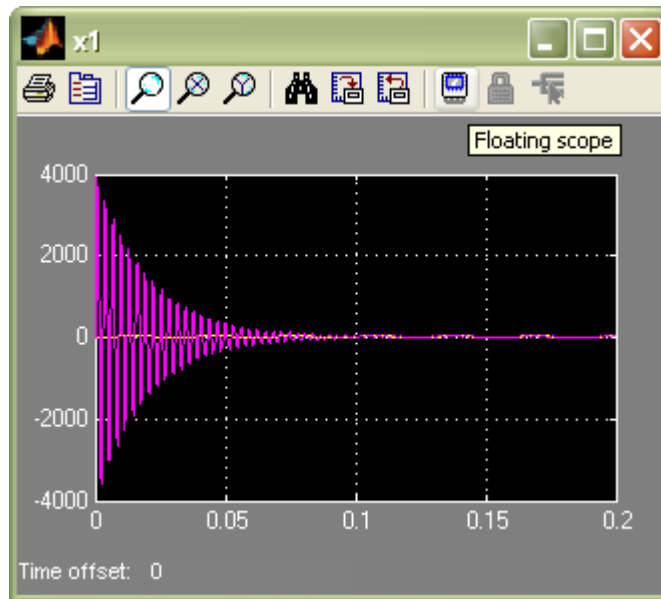

39.

a. From the solution of Problem III the system can be written in phase variable form as:

$$\mathbf{A}_z = \begin{bmatrix} 0 & 1 & 0 \\ 0 & 0 & 1 \\ -0.000078 & -0.01265 & -0.5250 \end{bmatrix}; \mathbf{B}_z = \begin{bmatrix} 0 \\ 0 \\ 1 \end{bmatrix};$$

$$\mathbf{C}_z = [-0.01197 \times 10^{-4} \quad -0.958 \times 10^{-4} \quad 0]; \mathbf{D}_z = 0$$

The corresponding observability matrix is:

$$\mathbf{O}_{Mz} = \begin{bmatrix} \mathbf{C}_z \\ \mathbf{C}_z \mathbf{A}_z \\ \mathbf{C}_z \mathbf{A}_z^2 \end{bmatrix} = \begin{bmatrix} -0.012 \times 10^{-4} & -0.958 \times 10^{-4} & 0 \\ 0 & -0.019 \times 10^{-4} & -0.958 \times 10^{-4} \\ 0.0001 \times 10^{-4} & 0.0121 \times 10^{-4} & 0.491 \times 10^{-4} \end{bmatrix}$$

It is readily verified that the rank of  $\mathbf{O}_{Mz}$  is 3 and the system is observable.

Next we write the system in observable canonical form, for this let

$$G(s) = \frac{C(s)}{R(s)} = \frac{-0.958 \times 10^{-4} s - 0.01197 \times 10^{-4}}{s^3 + 0.525s^2 + 0.01265s + 0.000078} = \frac{\frac{-0.958 \times 10^{-4}}{s^2} - \frac{0.01197 \times 10^{-4}}{s^3}}{1 + \frac{0.525}{s} + \frac{0.01265}{s^2} + \frac{0.000078}{s^3}}$$

From which we can write:

$$C(s) = \frac{1}{s} \left( -0.525C(s) + \frac{1}{s} \left( -0.958 \times 10^{-4} R(s) - 0.01265C(s) + \frac{1}{s} \left( -0.01197 \times 10^{-4} R(s) - 0.000078 \right) \right) \right)$$

Giving the following state flow diagram.

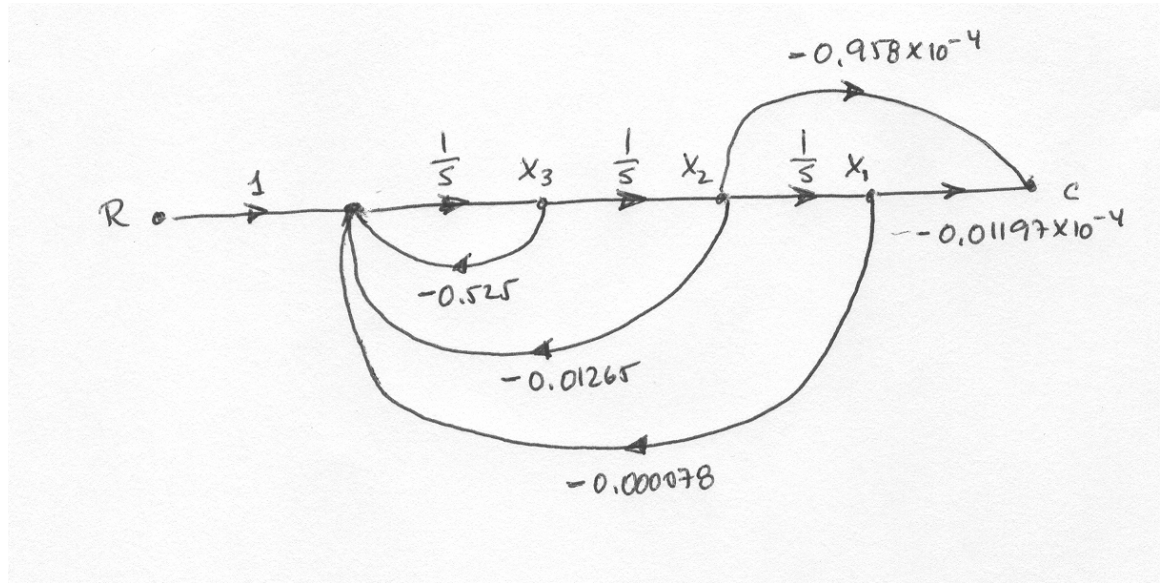

The system in observer canonical form is

$$\mathbf{A}_x = \begin{bmatrix} -0.5250 & 1 & 0 \\ -0.01265 & 0 & 1 \\ -0.000078 & 0 & 0 \end{bmatrix}; \mathbf{B}_x = \begin{bmatrix} 0 \\ -0.958 \times 10^{-4} \\ -0.01197 \times 10^{-4} \end{bmatrix};$$

$$\mathbf{C}_x = [1 \ 0 \ 0]; \mathbf{D}_x = 0$$

And

$$\mathbf{A}_x - \mathbf{L}_x \mathbf{C}_x = \begin{bmatrix} -(0.5250 + l_1) & 1 & 0 \\ -(0.01265 + l_2) & 0 & 1 \\ -(0.000078 + l_3) & 0 & 0 \end{bmatrix}$$

With a characteristic polynomial

$$s^3 + (0.525 + l_1)s^2 + (0.01265 + l_2)s + (0.000078 + l_3) = 0$$

The plant has poles at -0.5, -0.0128 and -0.0122. To obtain the tenfold speed increase in the observer arbitrarily we will place the observer poles 10 times to the left of the plant poles, namely -5, -0.128 and -0.122. The resulting desired polynomial is

$$s^3 + 0.75s^2 + 0.1406s + 0.007808 = 0$$

Comparing the observer and the desired polynomials

we obtain:

$$l_1 = 0.75 - 0.525 = 0.225$$

$$l_2 = 0.1406 - 0.01265 = 0.128$$

$$l_3 = 0.007808 - 0.000078 = 0.0077$$

$$\text{Or } \mathbf{L}_x = \begin{bmatrix} 0.225 \\ 0.128 \\ 0.0077 \end{bmatrix}$$

The observability matrix for the observable canonical system is:

$$\mathbf{O}_{Mx} = \begin{bmatrix} \mathbf{C}_x \\ \mathbf{C}_x \mathbf{A}_x \\ \mathbf{C}_x \mathbf{A}_x^2 \end{bmatrix} = \begin{bmatrix} 1 & 0 & 0 \\ -0.525 & 1 & 0 \\ 0.263 & -0.525 & 1 \end{bmatrix}$$

The transformation matrix is

$$\mathbf{P} = \mathbf{O}_{Mz}^{-1} \mathbf{O}_{mx} = \begin{bmatrix} 14 \times 10^4 & -688 \times 10^4 & 33480 \times 10^4 \\ -1 \times 10^4 & 14 \times 10^{-4} & -688 \times 10^4 \\ 1 \times 10^4 & -1 \times 10^4 & 14 \times 10^4 \end{bmatrix}$$

Finally

$$\mathbf{L}_z = \mathbf{O} \mathbf{L}_x = \begin{bmatrix} 1.7286 \times 10^6 \\ -379 \times 10^2 \\ 700 \end{bmatrix}$$

b.

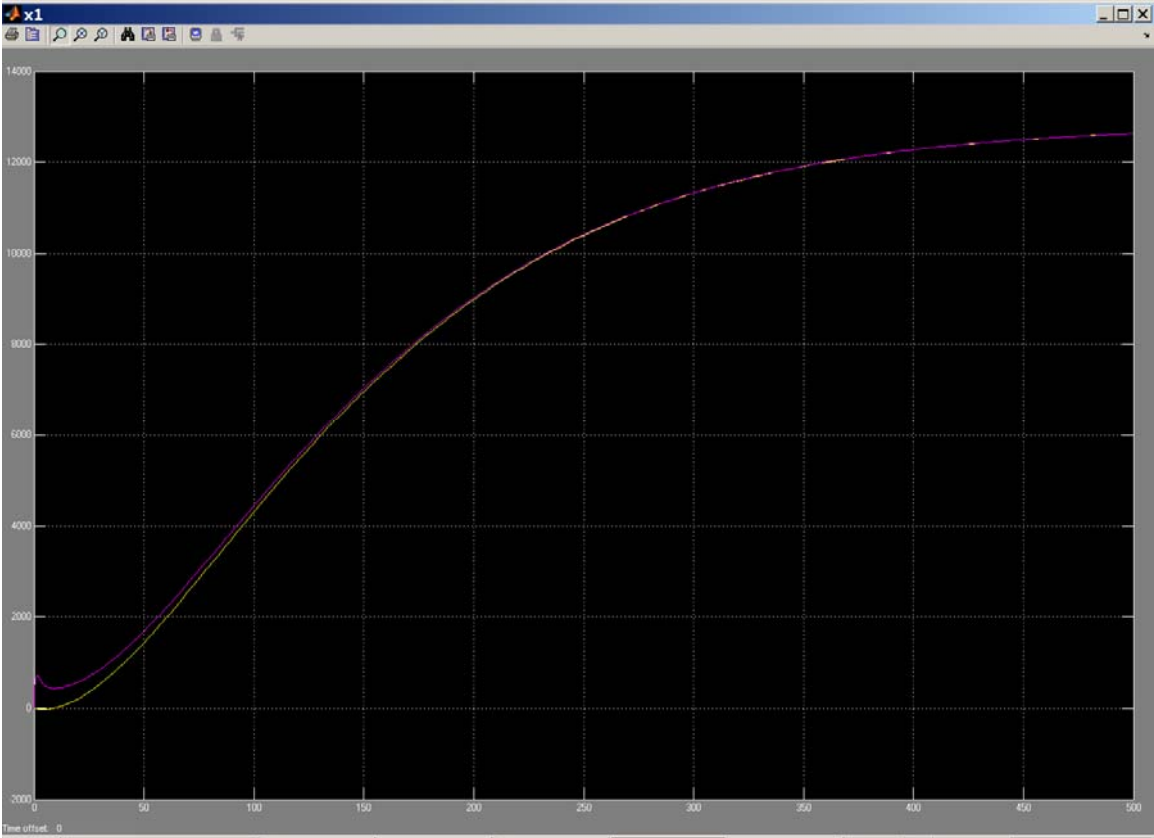
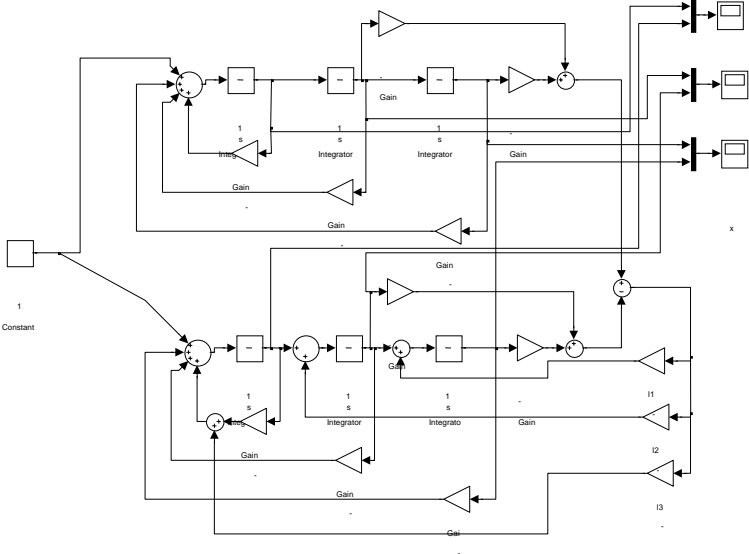

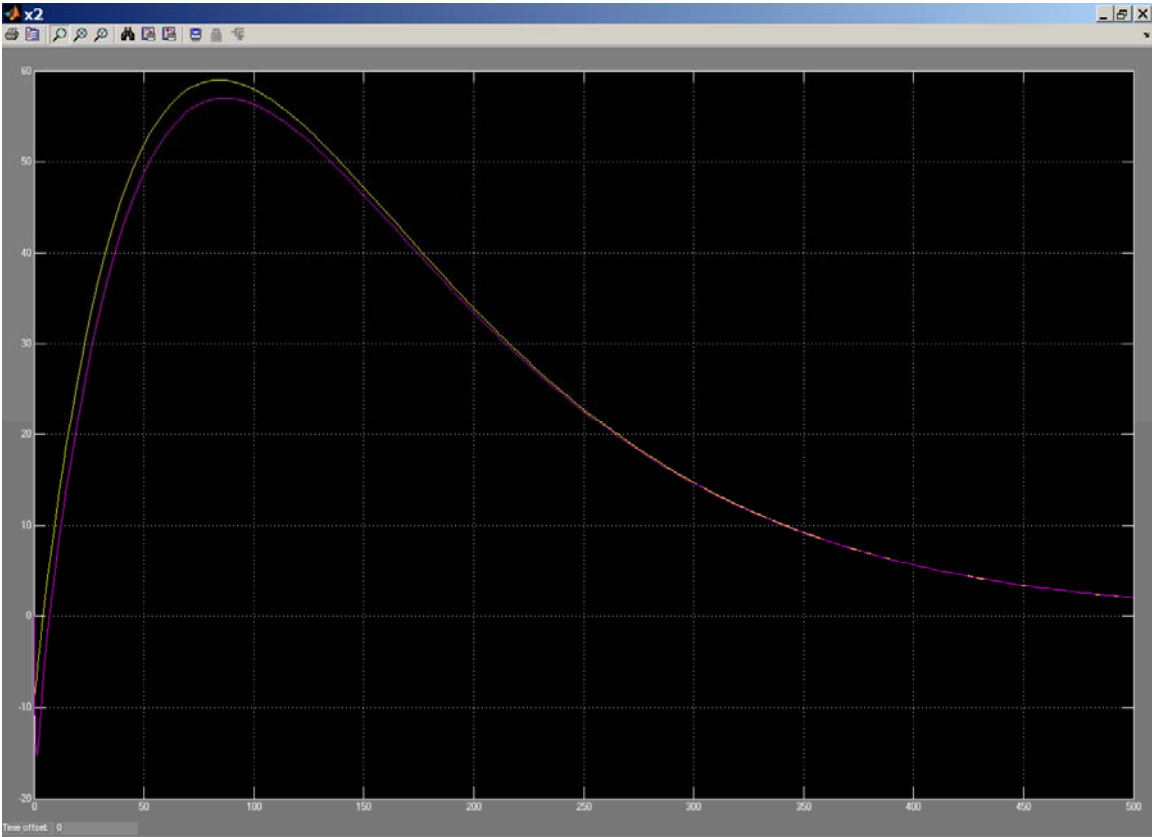

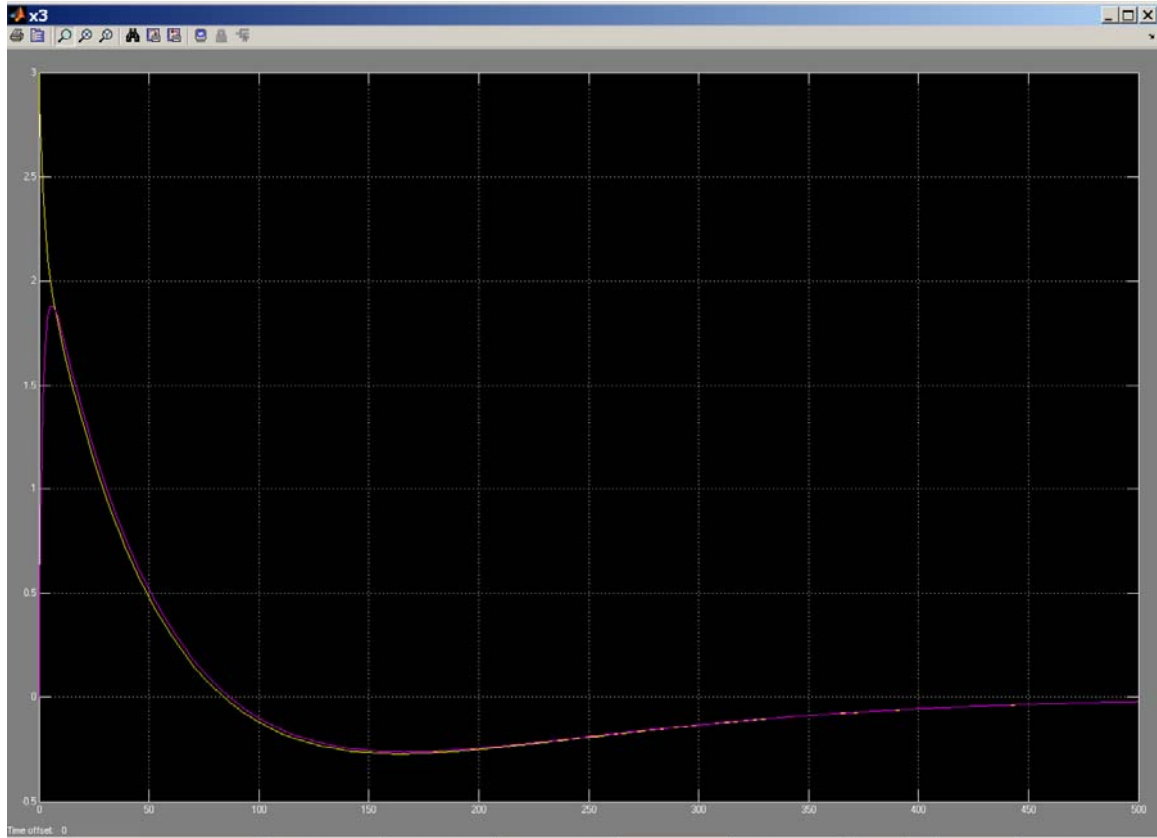

40.

**Controller design:**

The transfer function for the plant is

$$G(s) = \frac{5}{(s+0.4)(s+0.8)(s+5)} = \frac{5}{s^3 + 6.2s^2 + 6.32s + 1.6}$$

The characteristic polynomial for the plant with phase-variable state feedback is

$$s^3 + (6.2 + k_3)s^2 + (6.32 + k_2)s + (1.6 + k_1)$$

Using the given transient response of 5% overshoot and  $T_s = 10$  minutes, and placing the third pole ten times further from the imaginary axis than the dominant pair, the desired characteristic equation is

$$(s + 4)(s^2 + 0.8s + 0.336) = s^3 + 4.8s^2 + 3.536s + 1.344.$$

Comparing the two characteristic equations,  $k_1 = -0.256$ ,  $k_2 = -2.784$ , and  $k_3 = -1.4$ .

**Observer design:**

The **A** and **C** matrices for the system represented in phase-variable form is

<b>Az</b>		
0	1	0
0	0	1
-1.6	-6.32	-6.2

<b>Cz</b>		
5	0	0

The characteristic polynomial found from the transfer function of the plant is

$$s^3 + 6.2s^2 + 6.32s + 1.6$$

From this characteristic polynomial, we can write the dual phase-variable form of the state equations.

The **A** and **C** matrices of the dual phase-variable form are given below as

<b>Ax</b>		
-6.2	1	0
-6.32	0	1
-1.6	0	0
<b>Cx</b>		
1	0	0

To test observability, we write the observability matrices for both systems and show that both observability matrices have nonzero determinants. Using Eq. (12.79),

<b>OMz</b>	Observability Matrix of z		<b>OMx</b>	Observability Matrix of x	
5	0	0	1	0	0
0	5	0	-6.2	1	0
0	0	5	32.12	-6.2	1
<b>Det(OMz)</b>	125		<b>Det(OMx)</b>	1	

Using Eq. (12.89), we obtain the transformation matrix, **P**, and its inverse as

<b>P</b>	Transformation Matrix z=Px		<b>PINV</b>		
0.2	0	0	5.00	0.00	0.00
-1.24	0.2	0	31.00	5.00	0.00
6.424	-1.24	0.2	31.60	31.00	5.00

Using the characteristic polynomial given in the problem statement, the observer for the dual phase-variable system is

$$\mathbf{Lx}$$

$$\begin{matrix} 41.8 \\ 347.28 \\ 1342.4 \end{matrix}$$

Using Eq. (12.92), the observer for the cascade system is found to be

$$\mathbf{Lz}$$

$$\begin{matrix} 8.36 \\ 17.624 \\ 106.376 \end{matrix}$$

41.

a. As per equation (12.115) in the text the augmented system is:

$$\begin{aligned}
\begin{bmatrix} \dot{x}_1 \\ \dot{x}_2 \\ \dot{x}_N \end{bmatrix} &= \begin{bmatrix} \mathbf{A} - \mathbf{BK} & \mathbf{B}k_e \\ -\mathbf{C} & 0 \end{bmatrix} \begin{bmatrix} x_1 \\ x_2 \\ x_N \end{bmatrix} + \begin{bmatrix} 0 \\ 0 \\ 1 \end{bmatrix} r \\
&= \begin{bmatrix} 0 & -83.33 \\ 500 & -10 \\ & 0 & -1 \end{bmatrix} - \begin{bmatrix} 166.67 \\ 0 \end{bmatrix} [k_1 \quad k_2] \begin{bmatrix} 166.67 \\ 0 \\ 0 \end{bmatrix} k_e \begin{bmatrix} x_1 \\ x_2 \\ x_N \end{bmatrix} + \begin{bmatrix} 0 \\ 0 \\ 1 \end{bmatrix} r \\
&= \begin{bmatrix} -166.67k_1 & -(83.33 + 166.67k_2) & 166.67k_e \\ 500 & -10 & 0 \\ 0 & -1 & 0 \end{bmatrix} \begin{bmatrix} x_1 \\ x_2 \\ x_N \end{bmatrix} + \begin{bmatrix} 0 \\ 0 \\ 1 \end{bmatrix} r \\
y &= [\mathbf{C} \quad 0] \begin{bmatrix} x_1 \\ x_2 \\ x_N \end{bmatrix}
\end{aligned}$$

The characteristic equation for the system above is:

$$\begin{aligned}
\det(s\mathbf{I} - \mathbf{A}_{\text{aug}}) &= \begin{vmatrix} s + 166.67k_1 & 83.33 + 166.67k_2 & -166.67k_e \\ -500 & s + 10 & 0 \\ 0 & 1 & s \end{vmatrix} \\
&= s^3 + (10 + 166.67k_1)s^2 + (1666.7k_1 + 41665 + 83335k_2)s + 83335k_e
\end{aligned}$$

The desired polynomial for  $T_s = 0.5$  sec and %OS=20% with an extra far away pole is:

$$(s^2 + 16s + 130.65)(s + 50) = s^3 + 66s^2 + 930.6s + 6532.5$$

Equating coefficients in both polynomials we have:

$$10 + 166.67k_1 = 66 \Rightarrow k_1 = 0.336$$

$$1666.7k_1 + 41665 + 83335k_2 = 930.6 \Rightarrow k_2 = -0.4955$$

$$83335k_e = 6532.5 \Rightarrow k_e = 0.0783884$$



b.

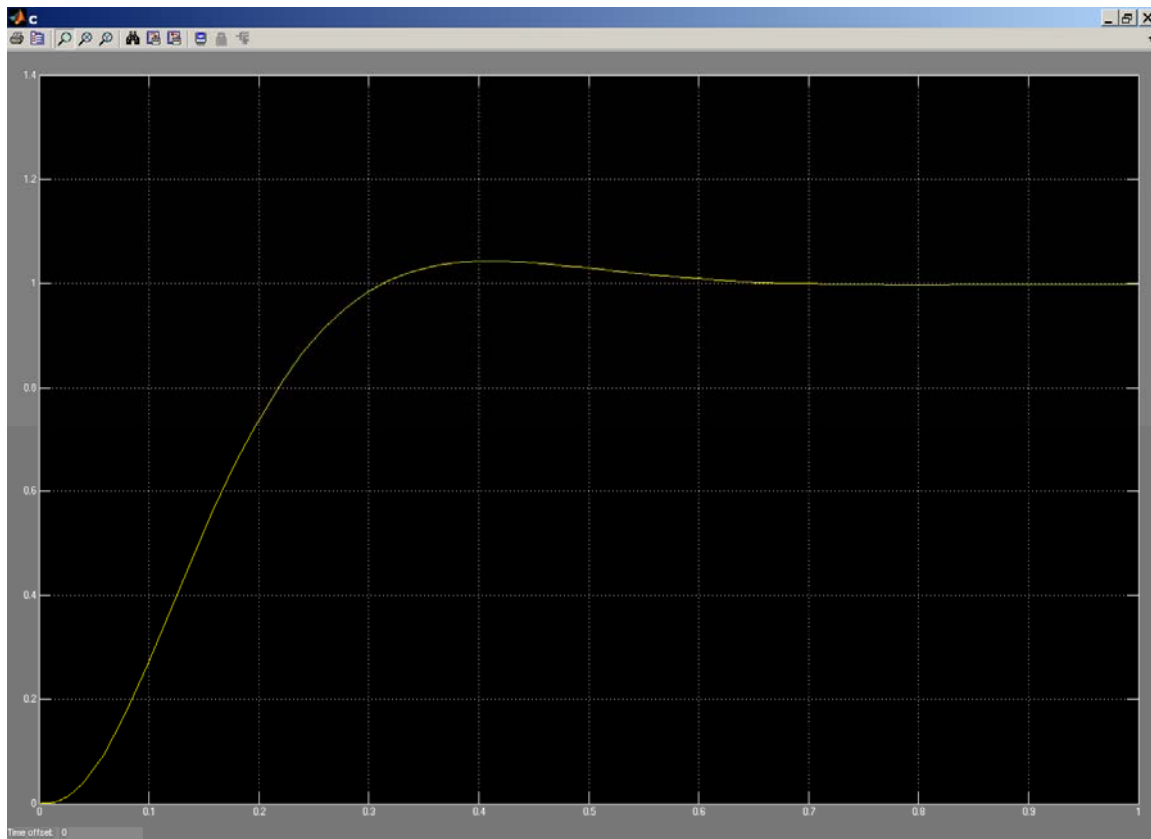
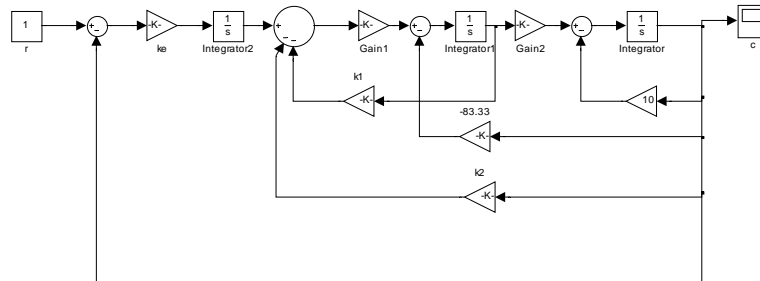

42.

a. Using the following signal-flow graph,

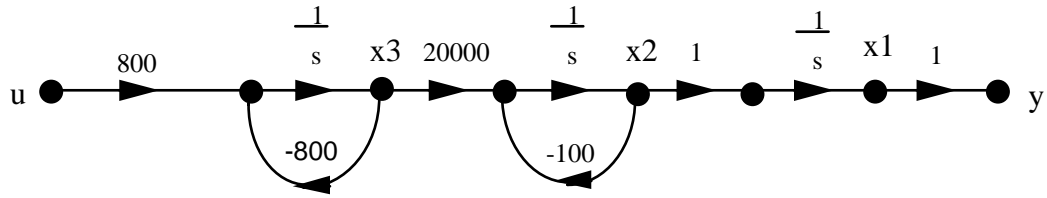

the plant is represented in state space with

$$\mathbf{A} = \begin{bmatrix} 0 & 1 & 0 \\ 0 & -100 & 20000 \\ 0 & 0 & -800 \end{bmatrix}; \mathbf{B} = \begin{bmatrix} 0 \\ 0 \\ 800 \end{bmatrix}; \text{ and } \mathbf{C} = [1 \ 0 \ 0].$$

Using Eq. (12.26),

$$\mathbf{C}_M = \begin{bmatrix} 0 & 0 & 1.6E07 \\ 0 & 1.6E07 & -1.44E10 \\ 800 & -6.4E05 & 5.12E08 \end{bmatrix}$$

The system is controllable since the determinant of  $\mathbf{C}_M = -2.04e^{17}$ . Use Eqs. (4.39) and (4.42) to find  $\zeta = 0.5912$  and  $\omega_n = 135.3283$  respectively. Factoring the denominator of Eq. (4.22), the required poles are  $-80 \pm j109.15$ . Place the third pole 10 times farther at  $= 800$ . Multiplying the three closed-loop pole terms yields the desired characteristic equation

$$s^3 + 960s^2 + 1.463E05s + 1.4651E07 = 0.$$

Since the plant's characteristic equation is  $s^3 + 900s^2 + 80000s$ , we write the plant in controller canonical form as

$$\mathbf{A}_{cc} = \begin{bmatrix} -900 & -80000 & 0 \\ 1 & 0 & 0 \\ 0 & 1 & 0 \end{bmatrix}; \mathbf{B}_{cc} = \begin{bmatrix} 1 \\ 0 \\ 0 \end{bmatrix}; \text{ and } \mathbf{C}_{cc} = [0 \ 0 \ 1.6E07]$$

The controllability matrix for controllable canonical form is

$$\mathbf{C}_{Mcc} = \begin{bmatrix} 1 & -900 & 730000 \\ 0 & 1 & -900 \\ 0 & 0 & 1 \end{bmatrix}$$

Comparing the first row of  $\mathbf{A}_{cc}$  to the desired characteristic equation and using the results of Problem 5,  $k_1 = -(900 - 960) = 60$ ;  $k_2 = -(80000 - 1.463E05) = 66300$ ; and  $k_3 = -(0 - 1.465E07) = 1.465E07$ .

Hence.

$$\mathbf{K}_{cc} = [60 \ 66300 \ 1.465E07]$$

The transformation matrix is,

$$\mathbf{P} = \mathbf{C}_M \mathbf{C}_{Mcc}^{-1} = \begin{bmatrix} 0 & 150 & 1.6E07 \\ 0 & 1.6E07 & 0 \\ 800 & 8E04 & 0 \end{bmatrix}$$

Transforming back to the original system,

$$\mathbf{K} = \mathbf{K}_{cc}\mathbf{P}^{-1} = [9.1569\text{E-}01 \quad 3.7696\text{E-}03 \quad 7.5\text{E-}02]$$

The controller compensated system is

$$\mathbf{A} - \mathbf{BK} = \begin{bmatrix} 0 & 1 & 0 \\ 0 & -100 & 20000 \\ -732.55 & -3.0157 & -860 \end{bmatrix}; \mathbf{B} = \begin{bmatrix} 0 \\ 0 \\ 800 \end{bmatrix}; \mathbf{C} = [1 \quad 0 \quad 0]$$

b. To evaluate the steady-state error, use Eq. (7.89) where

$$\mathbf{A} - \mathbf{BK} = \begin{bmatrix} 0 & 1 & 0 \\ 0 & -100 & 20000 \\ -732.55 & -3.0157 & -860 \end{bmatrix}$$

is the system matrix. Thus,

$$(s \mathbf{I} - [\mathbf{A} \quad -\mathbf{B} \quad \mathbf{K}])^{-1} = \frac{1}{s^3 + 960s^2 + 1.4631 \times 10^5 s + 14651040} \begin{pmatrix} s^2 + 960s + 1.4631 \times 10^5 & s + 860 & 20000 \\ -14651040 & s^2 + 860s & 20000s \\ -732.55s - 73255 & -3.0157s - 732.55 & s^2 + 100s \end{pmatrix}$$

The steady-state error is given by

$$sR(s)[1 - \mathbf{C}(s \mathbf{I} - [\mathbf{A} \quad -\mathbf{B} \quad \mathbf{K}])^{-1} \mathbf{B}] \text{ as } s \rightarrow 0$$

For a step input,  $R(s) = 1/s$ . Since

$$1 - \mathbf{C}(s \mathbf{I} - [\mathbf{A} \quad -\mathbf{B} \quad \mathbf{K}])^{-1} \mathbf{B} = 1 - \frac{1}{s^3 + 960s^2 + 1.4631 \times 10^5 s + 14651040} \cdot 16000000$$

for a step input  $e(\infty) = -0.092073$ . Using Eqs. 12.115, the system with integral control is:

$$\mathbf{A}_I = \begin{bmatrix} 0 & 1 & 0 & 0 \\ 0 & -100 & 20000 & 0 \\ -800K_1 & -800K_2 & -800K_3 - 800 & 800K_e \\ -1 & 0 & 0 & 0 \end{bmatrix}; \mathbf{B}_I = \begin{bmatrix} 0 \\ 0 \\ 0 \\ 1 \end{bmatrix};$$

$$\mathbf{C}_I = (1, 0, 0, 0)$$

Assume the following desired characteristic equation:

$$(s^3 + 960s^2 + 1.463\text{E}05s + 1.4651\text{E}07)(s + 1000) =$$

$$s^4 + 1960s^3 + 1.1063 \times 10^6 s^2 + 1.6096 \times 10^8 s + 1.4651 \times 10^{10} = 0,$$

which is the desired characteristic equation from part (a) plus an additional pole at -1000. But the integral controlled system characteristic equation is

$$|s\mathbf{I} - \mathbf{A}_I| = s^4 + 100(8K_3 + 9)s^3 + 80000(K_3 + 200K_2 + 1)s^2 + 16000000K_1s + 16000000K_e$$

Equating coefficients to the desired characteristic equation

$$100(8K_3 + 9) = 1960; 80000(K_3 + 200K_2 + 1) = 1.1063 \times 10^6; 16000000K_1 = 1.6096 \times 10^8;$$

$$16000000K_e = 1.4651 \times 10^{10}$$

Solving for the controller gains:  $K_e = 915.69$ ;  $K_1 = 10.06$ ;  $K_2 = 0.05752$ ; and  $K_3 = 1.325$ .

Substituting into  $\mathbf{A}_I$  yields the integral controlled system.

$$A_I = \begin{pmatrix} 0 & 1 & 0 & 0 \\ 0 & -100 & 20000 & 0 \\ -8048.2 & -46.016 & -1860 & 7.3255 \times 10^5 \\ -1 & 0 & 0 & 0 \end{pmatrix}; B_I = \begin{pmatrix} 0 \\ 0 \\ 0 \\ 1 \end{pmatrix}; C_I = (1, 0, 0, 0)$$

Finding the characteristic equation as a check yields

$$s^4 + 1960s^3 + 1.1063 \times 10^6 s^2 + 1.6096 \times 10^8 s + 1.4651 \times 10^{10}$$

which checks with the desired characteristic equation. Now check the steady-state error using Eq. (7.89) using the integral controlled system. We find the error is zero.

**c.**

**Program:**

```
'Controller Compensated'
A=[0 1 0;0 -100 20000;-732.55 -3.0157 -860];
B=[0;0;800];
C=[1 0 0];
D=0;
S=ss(A,B,C,D)
step(S)
title('Controller Compensated')
pause
'Integral Controller'
A=[0 1 0 0;0 -100 20000 0;-8048.2 -46.016 -1860 7.3255e05;-1 0 0 0];
B=[0;0;0;1];
C=[1 0 0 0];
D=0;
S=ss(A,B,C,D)
step(S)
title('Integral Controller')
```

**Computer response:**

ans =

Controller Compensated

a =

```
      x1    x2    x3
x1      0      1      0
x2      0    -100  2e+004
x3  -732.5  -3.016  -860
```

b =

```
      u1
x1      0
x2      0
x3     800
```

c =

```
      x1  x2  x3
y1     1  0  0
```

```
d =
    u1
y1 0
```

Continuous-time model.

```
ans =
```

Integral Controller

```
a =
      x1      x2      x3      x4
x1      0       1       0       0
x2      0     -100    2e+004     0
x3    -8048   -46.02   -1860  7.326e+005
x4      -1       0       0       0
```

```
b =
    u1
x1 0
x2 0
x3 0
x4 1
```

```
c =
      x1 x2 x3 x4
y1 1 0 0 0
```

```
d =
    u1
y1 0
```

Continuous-time model.

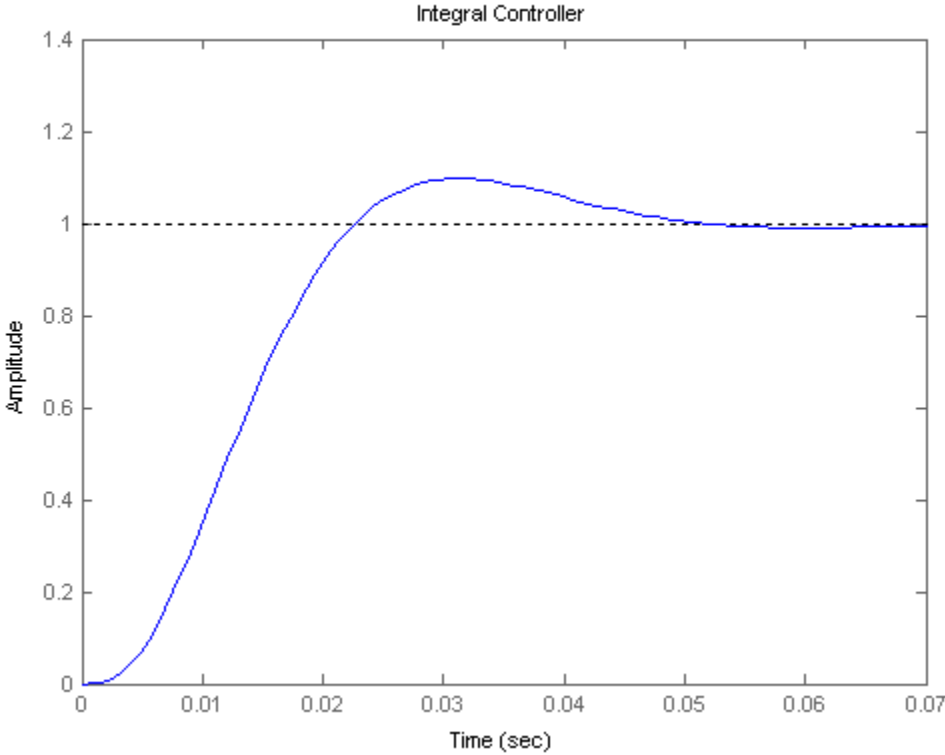
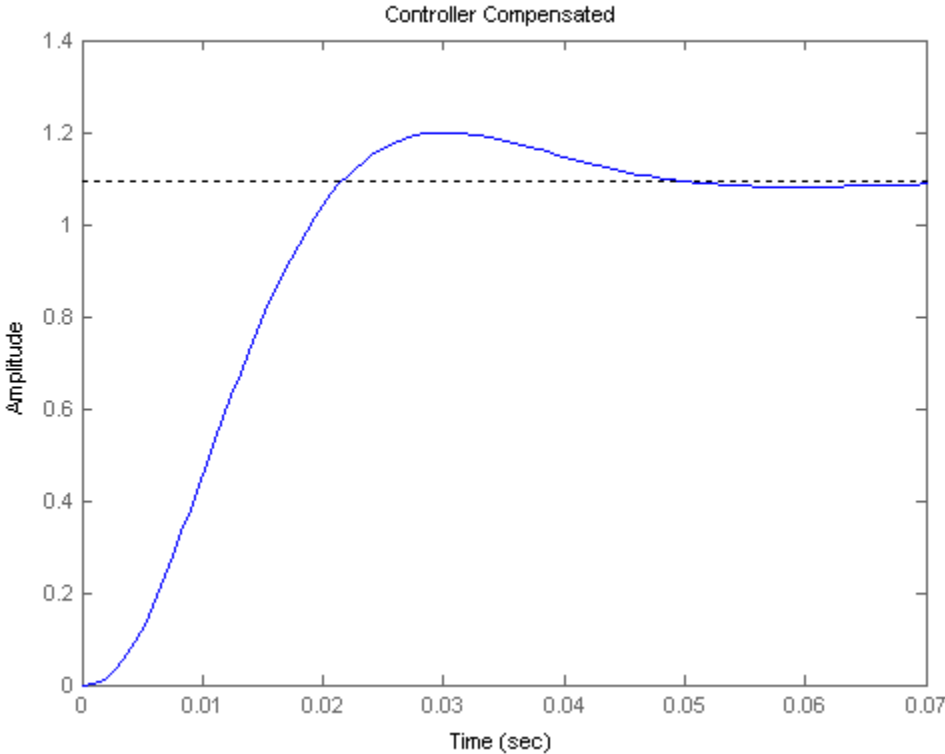

43.

**Program:**

```

%Enter G(s)
numg=0.072*conv([1 23],[1 0.05 0.04]);
deng=conv([1 0.08 0.04],poly([0.7 -1.7]));
'G(s)'
G=tf(numg,deng)
'Plant Zeros'
plantzeros=roots(numg)
%Input transient response specifications
Po=input('Type %OS ');
Ts=input('Type settling time ');

%Determine pole location
z=(-log(Po/100))/(sqrt(pi^2+log(Po/100)^2));
wn=4/(z*Ts);
%wn=pi/(Tp*sqrt(1-z^2));
[num,den]=ord2(wn,z);
r=roots(den);
poles=[r(1) r(2) plantzeros(2) plantzeros(3)]
characteristiceqdesired=poly(poles)

%Find controller canonical form of state-space representation of G(s)
'Controller Canonical Form'
[Ac Bc Cc Dc]=tf2ss(numg,deng)

%Design controller gains
Kc=acker(Ac,Bc,poles)
Acnew=Ac-Bc*Kc
Bcnew=Bc
Ccnew=Cc
Dcnew=Dc
characteristiceqcontroller=poly(eig(Acnew))

%Transform to phase-variable form
P=[0 0 0 1;0 0 1 0;0 1 0 0;1 0 0 0];
'Phase-variable form'
Ap=inv(P)*Ac*P
Bp=inv(P)*Bc
Cp=Cc*P
Dp=Dc
Kp=acker(Ap,Bp,poles)
Apnew=Ap-Bp*Kp
Bpnew=Bp
Cpnew=Cp
Dpnew=Dp
characteristiceqphase=poly(eig(Apnew))
[numt,dent]=ss2tf(Apnew,Bpnew,Cpnew,Dpnew);
T=tf(numt,dent);
'T(s)'
T=minreal(T)
step(T)
'T(s)'
Tzpk=zpk(T)
'Poles of T(s)'
p=pole(T)

```

**Computer response:**

ans =

G(s)

Transfer function:

$$\frac{0.072 s^3 + 1.66 s^2 + 0.08568 s + 0.06624}{s^4 + 1.08 s^3 - 1.07 s^2 - 0.0552 s - 0.0476}$$

ans =

Plant Zeros

plantzeros =

-23.0000  
-0.0250 + 0.1984i  
-0.0250 - 0.1984i

Type %OS 10

Type settling time 0.5

poles =

-8.0000 +10.9150i -8.0000 -10.9150i -0.0250 + 0.1984i -0.0250 -  
0.1984i

characteristicqdesired =

1.0000 16.0500 183.9775 9.7969 7.3255

ans =

Controller Canonical Form

Ac =

-1.0800	1.0700	0.0552	0.0476
1.0000	0	0	0
0	1.0000	0	0
0	0	1.0000	0

Bc =

1  
0  
0  
0

Cc =

0.0720 1.6596 0.0857 0.0662

Dc =

0

Kc =



12-64 Chapter 12: Design via State Space

14.9700 185.0475 9.8521 7.3731

Acnew =

-16.0500 -183.9775 -9.7969 -7.3255  
 1.0000 0 0 0  
 0 1.0000 0 0  
 0 0 1.0000 0

Bcnew =

1  
 0  
 0  
 0

Ccnew =

0.0720 1.6596 0.0857 0.0662

Dcnew =

0

characteristiceqcontroller =

1.0000 16.0500 183.9775 9.7969 7.3255

ans =

Phase-variable form

Ap =

0 1.0000 0 0  
 0 0 1.0000 0  
 0 0 0 1.0000  
 0.0476 0.0552 1.0700 -1.0800

Bp =

0  
 0  
 0  
 1

Cp =

0.0662 0.0857 1.6596 0.0720

Dp =

0

Kp =

7.3731    9.8521    185.0475    14.9700

Apnew =

```

      0      1.0000      0      0
      0      0      1.0000      0
      0      0      0      1.0000
-7.3255 -9.7969 -183.9775 -16.0500

```

Bpnew =

```

0
0
0
1

```

Cpnew =

0.0662    0.0857    1.6596    0.0720

Dpnew =

0

characteristicphase =

1.0000    16.0500    183.9775    9.7969    7.3255

ans =

T(s)

Transfer function:

```

0.072 s + 1.656
-----
s^2 + 16 s + 183.1

```

ans =

T(s)

Zero/pole/gain:

```

0.072 (s+23)
-----
(s^2 + 16s + 183.1)

```

ans =

Poles of T(s)

p =

```

-8.0000 +10.9150i
-8.0000 -10.9150i

```

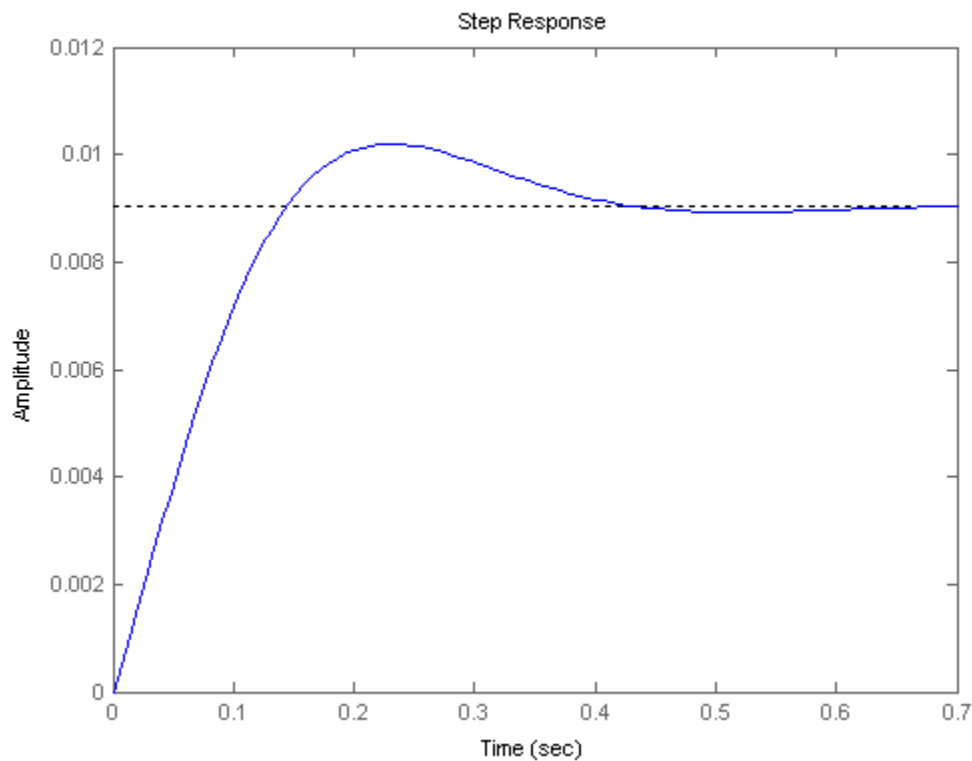

44.

**Program:**

```

%Enter G(s)
numg=0.072*conv([1 23],[1 0.05 0.04]);
deng=conv([1 0.08 0.04],poly([0.7 -1.7]));
'Uncompensated Plant Transfer Function'
'G(s)'
G=tf(numg,deng)
'Uncompensated Plant Zeros'
plantzeros=roots(numg)
%Input transient response specifications
Po=input('Type %OS ');
Ts=input('Type settling time ');

%Determine pole location
z=(-log(Po/100))/(sqrt(pi^2+log(Po/100)^2));
wn=4/(z*Ts);
%wn=pi/(Tp*sqrt(1-z^2));
[num,den]=ord2(wn,z);
r=roots(den);
'Desired Observer Poles'
poles=[r(1) r(2) plantzeros(2) plantzeros(3)]
'Desired Characteristic Equation of Observer'
poly(poles)

%Find phase variable form of state-space representation of Estimated Plant
%Find controller canonical form
[Ac Bc Cc Dc]=tf2ss(numg,deng);

%Transform to phase-variable form of Uncompensated Plant
P=[0 0 0 1;0 0 1 0;0 1 0 0;1 0 0 0];
'Phase-variable form of Estimated Plant'
Ap=inv(P)*Ac*P

```

```

Bp=inv(P)*Bc
Cp=Cc*P
Dp=Dc

%Design observer gains for phase variables
'Observer gains'
Lp=acker(Ap',Cp',poles)'
'Error System Matrix'
Aep=Ap-Lp*Cp
'Error System Eigenvalues'
eig(Aep)
'Error Characteristic Polynomial'
poly(eig(Aep))

```

**Computer response:**

ans =

Uncompensated Plant Transfer Function

ans =

G(s)

Transfer function:

$$\frac{0.072 s^3 + 1.66 s^2 + 0.08568 s + 0.06624}{s^4 + 1.08 s^3 - 1.07 s^2 - 0.0552 s - 0.0476}$$

ans =

Uncompensated Plant Zeros

plantzeros =

```

-23.0000
-0.0250 + 0.1984i
-0.0250 - 0.1984i

```

Type %OS 10

Type settling time 0.5/15

ans =

Desired Observer Poles

poles =

```

1.0e+002 *
-1.2000 - 1.6373i
-1.2000 + 1.6373i
-0.0003 - 0.0020i
-0.0003 + 0.0020i

```

ans =

Desired Characteristic Equation of Observer

12-68 Chapter 12: Design via State Space

```
ans =
1.0e+004 *
0.0001    0.0240    4.1218    0.2070    0.1648
```

```
ans =
Phase-variable form of Estimated Plant
```

```
Ap =
0    1.0000    0    0
0    0    1.0000    0
0    0    0    1.0000
0.0476    0.0552    1.0700    -1.0800
```

```
Bp =
```

```
0
0
0
1
```

```
Cp =
```

```
0.0662    0.0857    1.6596    0.0720
```

```
Dp =
```

```
0
```

```
ans =
```

```
Observer gains
```

```
Lp =
```

```
1.0e+004 *
-0.0002
0.0043
-0.0986
2.5994
```

```
ans =
```

```
Error System Matrix
```

```
Aep =
```

```
1.0e+004 *
0.0000    0.0001    0.0003    0.0000
-0.0003   -0.0004   -0.0071   -0.0003
0.0065    0.0084    0.1636    0.0072
-0.1722   -0.2227   -4.3139   -0.1873
```

ans =

Error System Eigenvalues

ans =

```
1.0e+002 *
-1.2000 + 1.6373i
-1.2000 - 1.6373i
-0.0003 + 0.0020i
-0.0003 - 0.0020i
```

ans =

Error Characteristic Polynomial

ans =

```
1.0e+004 *
0.0001    0.0240    4.1218    0.2070    0.1648
```

45.

a. Using Eqs. (12.115), the system with integral control is:

$$A_I = \begin{pmatrix} 0 & 1 & 0 & 0 & 0 \\ 0 & 0 & 1 & 0 & 0 \\ 0 & 0 & 0 & 1 & 0 \\ -K_1 + 0.0476 & -K_2 + 0.0552 & -K_3 + 1.07 & -K_4 - 1.08 & K_e \\ -0.06624 & -0.08568 & -1.6596 & -0.072 & 0 \end{pmatrix}; B_I = \begin{pmatrix} 0 \\ 0 \\ 0 \\ 0 \\ 1 \end{pmatrix};$$

$$C_I = (1, 0, 0, 0, 0)$$

Assume the following desired characteristic equation,

$$(s + 8 + 10.915i)(s + 8 - 10.915i)(s + 0.025 + 0.1984i)(s + 0.025 - 0.1984i)(s + 23) = s^5 + 39.05s^4 + 553.13s^3 + 4241.3s^2 + 232.65s + 168.43$$

which is the desired characteristic equation from Problem 35 plus an additional pole at -23, the

closed-loop zero. But the integral controlled system characteristic equation is  $|s\mathbf{I} - \mathbf{A}_I| =$

$$s^5 + (K_4 + 1.08)s^4 + (K_3 + 0.072K_e - 1.07)s^3 + (K_2 + 1.6596K_e - 0.0552)s^2 + (K_1 + 0.08568K_e - 0.0476)s + 0.06624K_e$$

Equating coefficients to the desired characteristic equation

$$K_4 + 1.08 = 39.05; K_3 + 0.072K_e - 1.07 = 553.13; K_2 + 1.6596K_e - 0.0552 = 4241.3; K_1 + 0.08568K_e - 0.0476 = 232.65; \text{ and } 0.06624K_e = 168.43$$

Solving for the controller gains

$$K_1 = 14.829; K_2 = 21.328; K_3 = 371.12; K_4 = 37.97 \text{ and } K_e = 2542.8$$

Substituting into  $\mathbf{A}_I$  yields the integral controlled system,

$$A_I = \begin{pmatrix} 0 & 1 & 0 & 0 & 0 \\ 0 & 0 & 1 & 0 & 0 \\ 0 & 0 & 0 & 1 & 0 \\ -14.781 & -21.272 & -370.05 & -39.05 & 2542.8 \\ -0.06624 & -0.08568 & -1.6596 & -0.072 & 0 \end{pmatrix}; B_I = \begin{pmatrix} 0 \\ 0 \\ 0 \\ 0 \\ 1 \end{pmatrix};$$

$$C_I = (0.06624, 0.08568, 1.6596, 0.072, 0)$$

Finding the characteristic equation as a check yields

$$s^5 + 39.05 s^4 + 553.13 s^3 + 4241.3 s^2 + 232.65 s + 168.43$$

which checks with the desired. Now check the steady-state error using Eq. (7.89) using the integral controlled system. We find the error is zero.

**b.**

**Program:**

```
%Design with Integral Control
'State-Space Representation of System with Integral Control'
AI=[0 1 0 0 0;0 0 1 0 0;0 0 0 1 0;...
-14.781 -21.272 -370.05 -39.05 2542.8;...
-0.06624 -0.08568 -1.6596 -0.072 0]
BI=[0;0;0;0;1]
CI=[0.06624 0.08568 1.6596 0.072 0]
DI=0

%Convert to transfer function
[numt,dent]=ss2tf(AI,BI,CI,DI);
'Integral Control Transfer Function'
'T(s)'
T=tf(numt,dent)
'Integral Control Transfer Function Zeros'
roots(numt)
'Integral Control Transfer Function Poles'
roots(dent)
step(T)
title('Step Response with Integral Controller')
```

**Computer response:**

ans =

State-Space Representation of System with Integral Control

AI =

```
1.0e+003 *
      0      0.0010      0      0      0
      0      0      0.0010      0      0
      0      0      0      0.0010      0
 -0.0148 -0.0213 -0.3700 -0.0390  2.5428
 -0.0001 -0.0001 -0.0017 -0.0001      0
```

BI =

```
0
0
0
0
1
```

CI =  
 0.0662    0.0857    1.6596    0.0720    0

DI =  
 0

ans =  
 Integral Control Transfer Function

ans =  
 T(s)

Transfer function:  

$$\frac{-1.421e-014 s^4 + 183.1 s^3 + 4220 s^2 + 217.9 s + 168.4}{s^5 + 39.05 s^4 + 553.1 s^3 + 4241 s^2 + 232.6 s + 168.4}$$

ans =  
 Integral Control Transfer Function Zeros

ans =  
 1.0e+016 \*  
 1.2883  
 -0.0000  
 -0.0000 + 0.0000i  
 -0.0000 - 0.0000i

ans =  
 Integral Control Transfer Function Poles

ans =  
 -22.9998  
 -8.0001 +10.9151i  
 -8.0001 -10.9151i  
 -0.0250 + 0.1984i  
 -0.0250 - 0.1984i



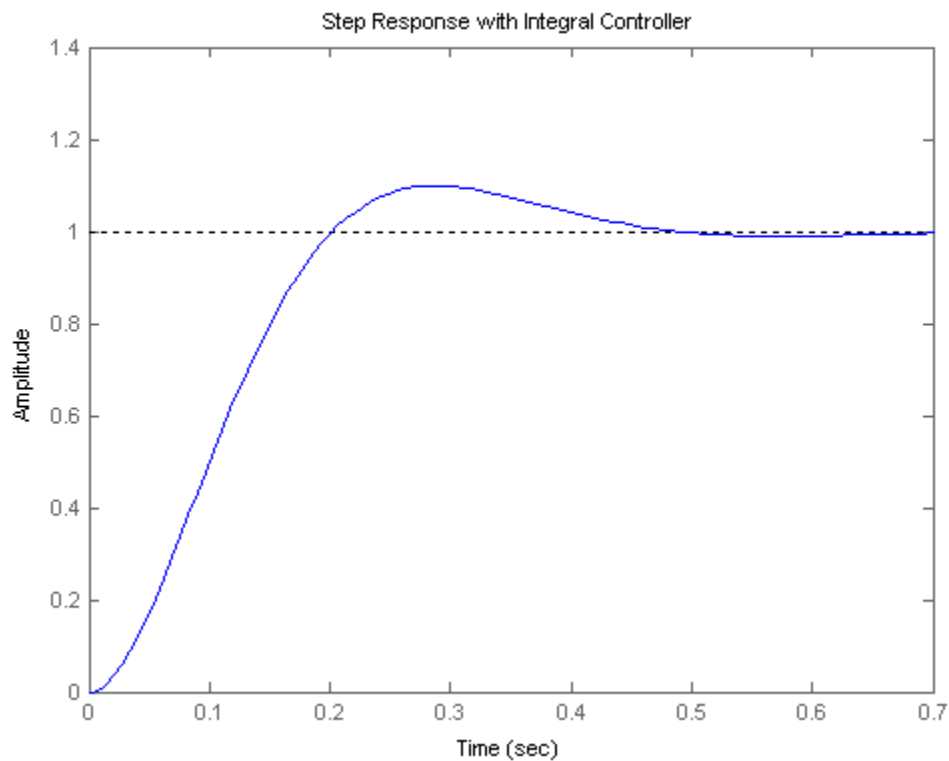

46.

a. We start by verifying that the system is controllable. For a system of this order it is best to use MATLAB or other computing tools:

```
>>A=[-5 0 0 0 0; 0 0 1 0 0; -10.5229 -1066.67 -3.38028 23.5107 0; 0 993.804 3.125 -23.5107 0; 0 0
0 10 -10];
>>B = [5;0;0;0;0];
>>C = [0 0 0 1.2331e5 0];
>>D=0;
>>rank(ctrb(A,B))
```

ans =

5

So the system is controllable.

We also use MATLAB to find the corresponding transfer function:

```
>> [n,d]=ss2tf(A,B,C,D)
```

n =

1.0e+010 \*

```
0 0.0000000000000000 0.0000000000000000 -0.002027466873438 -
0.665044169115073 -6.447695003806981
```

d =

1.0e+004 \*

0.000100000000000 0.004189098000000 0.152603651149600 1.914775683863999  
7.933055056779999 8.565653331000014

We use this information to express the system in state variable form:

$$x'_x = \begin{bmatrix} 0 & 1 & 0 & 0 & 0 \\ 0 & 0 & 1 & 0 & 0 \\ 0 & 0 & 0 & 1 & 0 \\ 0 & 0 & 0 & 0 & 1 \\ -85650 & -79330 & -19150 & -1526 & -41.89 \end{bmatrix} x + \begin{bmatrix} 0 \\ 0 \\ 0 \\ 0 \\ 1 \end{bmatrix} u$$

$$y = [-64476950038.1 \quad -6650441691.2 \quad -20274668.73 \quad 0 \quad 0] x_x$$

Now we find the desired characteristic polynomial using a dominant pole approximation.

Assuming a pair of complex conjugate dominant poles  $T_s = \frac{4}{\xi\omega_n} = 2s$ , or  $\xi\omega_n = 2$ . The

10% OS requirement corresponds to a  $\xi = 0.6$  damping factor. Therefore the dominant poles can be included in a  $s^2 + 2\xi\omega_n s + \omega_n^2 = s^2 + 4s + 11.11$ . There must be a total of 5 poles so arbitrarily we will add three poles 10 times to the left of the dominant poles, namely  $(s + 20)^3$ . Thus the desired polynomial is given by:

$$\begin{aligned} D(s) &= (s^2 + 4s + 11.11)(s + 20)^3 \\ &= s^5 + 64s^4 + 1451.11s^3 + 13466.77s^2 + 45335.47s + 88903.11 \end{aligned}$$

Under state feedback, the phase variable system will become

$$x'_x = \begin{bmatrix} 0 & 1 & 0 & 0 & 0 \\ 0 & 0 & 1 & 0 & 0 \\ 0 & 0 & 0 & 1 & 0 \\ 0 & 0 & 0 & 0 & 1 \\ -(85650 + k_{1x}) & -(79330 + k_{2x}) & -(19150 + k_{3x}) & -(1526 + k_{4x}) & -(41.89 + k_{5x}) \end{bmatrix} x + \begin{bmatrix} 0 \\ 0 \\ 0 \\ 0 \\ 1 \end{bmatrix} u$$

With a characteristic equation given by:

$$\begin{aligned} \det(sI - (A_x - B_x K_x)) \\ = s^5 + (41.89 + k_{5x})s^4 + (1526 + k_{4x})s^3 + (19150 + k_{3x})s^2 \\ + (79330 + k_{2x})s + (85650 + k_{1x}) \end{aligned}$$

We now equate the coefficients of this equation with those of the desired polynomial to get:

$$K_x = [k_{1x} \quad k_{2x} \quad k_{3x} \quad k_{4x} \quad k_{5x}] = [3253.11 \quad -33994.53 \quad -5683.28 \quad -74.89 \quad 22.11]$$

This vector is now transformed to the original coordinate system using MATLAB:

```
>> Ax=[0 1 0 0 0; 0 0 1 0 0; 0 0 0 1 0; 0 0 0 0 1;-8.565653331000014e4 -
7.933055056779999E4 -1.914775683863999e4 -0.152603651149600E4 -
0.004189098000000E4];
>> Bx = [0;0;0;0;1];
>> P=ctrb(A,B)*inv(ctrb(Ax,Bx));
>> Kz=Kx*inv(P);

K = [4.422  110.04  16.93  -1.75  -0.14]
```

**b.** The simulation is performed with the following commands:

```
>> Af=(A-B*Kz)
>> step(Af,B,C,D)
```

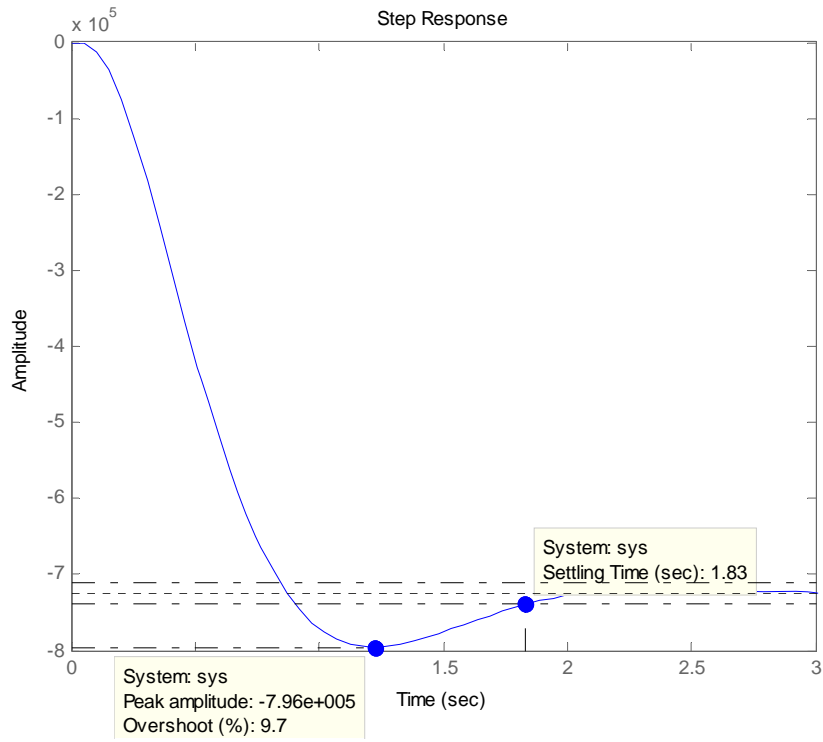

47.

a.

The open-loop block diagram is

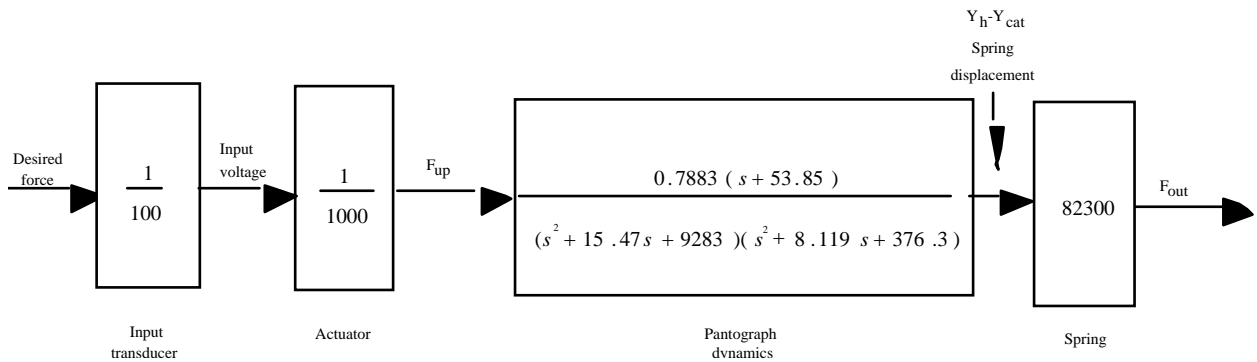

From Chapter 3, the state-space representation for  $[Y_h(s) - Y_{cat}(s)]/F_{up}(s)$  is

$$\dot{\mathbf{x}} = \begin{bmatrix} 0 & 1 & 0 & 0 \\ -9353 & -14.286 & 769.23 & 14.286 \\ 0 & 0 & 0 & 1 \\ 406.98 & 7.5581 & -406.98 & -9.3023 \end{bmatrix} \mathbf{x} + \begin{bmatrix} 0 \\ 0 \\ 0 \\ 0.0581 \end{bmatrix} f_{up}$$

$$y = [0.94911 \quad 0 \quad 0 \quad 0] \mathbf{x}$$

where  $y = y_h - y_{cat}$  and  $\mathbf{x} = \begin{bmatrix} y_h \\ \dot{y}_h \\ y_f \\ \dot{y}_f \end{bmatrix}$

Let  $v_i$  represent the input voltage shown on the diagram. Thus,  $f_{up} = v_i/1000$ .

Also,  $f_{out} = 82300(y_h - y_{cat})$ .

Thus,  $f_{out} = 82300y$

Substituting  $f_{up}$  and  $f_{out}$  into the state-equations above yields

$$\dot{\mathbf{x}} = \begin{bmatrix} 0 & 1 & 0 & 0 \\ -9353 & -14.286 & 769.23 & 14.286 \\ 0 & 0 & 0 & 1 \\ 406.98 & 7.5581 & -406.98 & -9.3023 \end{bmatrix} \mathbf{x} + \begin{bmatrix} 0 \\ 0 \\ 0 \\ 0.0581 \times 10^{-3} \end{bmatrix} v_i$$

$$f_{out} = [78,112 \quad 0 \quad 0 \quad 0] \mathbf{x}$$

Thus,

$$\mathbf{A} = \begin{bmatrix} 0 & 1 & 0 & 0 \\ -9353 & -14.286 & 769.23 & 14.286 \\ 0 & 0 & 0 & 1 \\ 406.98 & 7.5581 & -406.98 & -9.3023 \end{bmatrix}$$

$$\mathbf{B} = \begin{bmatrix} 0 \\ 0 \\ 0 \\ 0.0581 \times 10^{-3} \end{bmatrix}$$

$$\mathbf{K} = [k_1 \quad k_2 \quad k_3 \quad k_4]$$

Hence,

$$\mathbf{A} - \mathbf{BK} =$$

$$[0, 1, 0, 0]$$

$$[-9350, -14.3, 769, 14.3]$$

$$[0, 0, 0, 1]$$

$$[407 - 0.0000581 k_1, 7.56 - .0000581 k_2, -407 - 0.0000581 k_3, -9.30 - 0.0000581 k_4]$$

and

$$\begin{aligned} |\mathbf{A-BK}| = & s^4 + (0.0000581 k_4 + 23.60) s^3 \\ & + (0.00083083 k_4 + 0.00083083 k_2 + 9781.882 + 0.0000581 k_3) s^2 \\ & + (0.00083083 k_1 + 81141.36 + 0.543235 k_4 + 0.00083083 k_3 + 0.0446789 k_2) s \\ & + (0.0446789 k_1 + 0.3492467 \cdot 10^7 + 0.543235 k_3) \end{aligned}$$

Input transient response specifications,

$$P_o = 20$$

$$T_s = 1$$

yields poles at

$$-4.0000 + 7.8079i, -4.0000 - 7.8079i, -53.8500, -50.0000$$

Thus, the desired characteristic equation is

$$s^4 + 112s^3 + 3600s^2 + 29500s + 207000 = 0$$

We now equate the coefficients of  $|\mathbf{A-BK}|$  to the coefficients of the desired characteristic equation.

For compactness we solve for the coefficients,  $\mathbf{K}$ , using the form  $\mathbf{FK} = \mathbf{G}$ , where

$$\mathbf{F} = \begin{matrix} 0 & 0 & 0 & 0.0000581 \\ 0 & 0.00083083 & 0.0000581 & 0.00083083 \\ 0.00083083 & 0.0446789 & 0.00083083 & 0.543235 \\ 0.0446789 & 0 & 0.543235 & 0 \end{matrix}$$

and

$$\mathbf{G} = \begin{matrix} 88.4 \\ -6181.882 \\ -51641.36 \\ -3285467 \end{matrix}$$

Solving for  $\mathbf{K}$  using  $\mathbf{K} = \mathbf{F}^{-1}\mathbf{G}$

$$\mathbf{K} = \begin{matrix} -4.8225e8 \\ -0.1131e8 \\ 0.3361e8 \\ 0.0152e8 \end{matrix}$$

**b.**  
**Integral Control Design**

$$\mathbf{A} = \begin{matrix} 1.0e+03 * & & & \\ 0 & 0.0010 & 0 & 0 \\ -9.3530 & -0.0143 & 0.7692 & 0.0143 \\ 0 & 0 & 0 & 0.0010 \\ 0.4070 & 0.0076 & -0.4070 & -0.0093 \end{matrix}$$

$$\mathbf{B} =$$

$$\begin{matrix} 1.0e-04 * \\ 0 \\ 0 \\ 0 \\ 0.5810 \end{matrix}$$

$$\mathbf{C} = \begin{matrix} 78112 & 0 & 0 & 0 \end{matrix}$$

$$\mathbf{A}_{aug} = \mathbf{A} - \mathbf{BK} =$$

$$\begin{matrix} [0, 1., 0, 0, 0 \\ [-9350., -14.3, 769., 14.3, 0 \\ [0, 0, 0, 1., 0 \\ [407. - 0.0000581 k_1, 7.56 - 0.0000581 k_2, -407. - 0.0000581 k_3, \\ -9.30 - 0.0000581 k_4, 0.0000581 K_e \\ [-78100., 0, 0, 0, 0] \end{matrix}$$

Desired poles

$$P_o = 20$$

$$T_s = 1$$

Determine pole location

$$\text{poles} = -4.0000 + 7.8079i, -4.0000 - 7.8079i, -53.85, -50, -50$$

Desired characteristic equation

$$s^5 + 162s^4 + 0.919e4s^3 + 0.210e6s^2 + 0.168e7s + 0.104e8$$

System characteristic equation

$$\begin{aligned} |\mathbf{sI} - \mathbf{A}_{aug}| = & s^5 + (23.60 + 0.0000581 k_4) s^4 \\ & + (0.00083083 k_4 + 0.00083083 k_2 + 0.0000581 k_3 + 9781.882) s^3 \\ & + (0.00083083 k_1 + 81141.36 + 0.0446789 k_2 + 0.543235 k_4 + 0.00083083 k_3) s^2 \\ & + (0.0446789 k_1 + 64.887823 K_e + 0.543235 k_3 + 0.3492467 \cdot 10^7) s \\ & + 3489.42209 K_e \end{aligned}$$

Solving for Coefficients,  $\mathbf{K}$ , using  $\mathbf{FK} = \mathbf{G}$  as in (a), where

$$\mathbf{F} = \begin{matrix} 0 & 0 & 0 & 5.8100e-05 & 0 \\ 0 & 8.3083e-04 & 5.8100e-05 & 8.3083e-04 & 0 \\ 8.3083e-04 & 4.4679e-02 & 8.3083e-04 & 5.4324e-01 & 0 \\ 4.4679e-02 & 0 & 5.4324e-01 & 0 & 6.4888e+01 \\ 0 & 0 & 0 & 0 & 3.4894e+03 \end{matrix}$$

$$\mathbf{G} = \begin{matrix} 1.3840e+02 \\ -5.9188e+02 \\ 1.2886e+05 \\ -1.8125e+06 \\ 1.0800e+07 \end{matrix}$$

Thus,

$$\mathbf{K} = \begin{bmatrix} -1.0157\text{e}+09 \\ -8.6768\text{e}+06 \\ 7.9827\text{e}+07 \\ 2.3821\text{e}+06 \\ 3.0951\text{e}+03 \end{bmatrix}$$

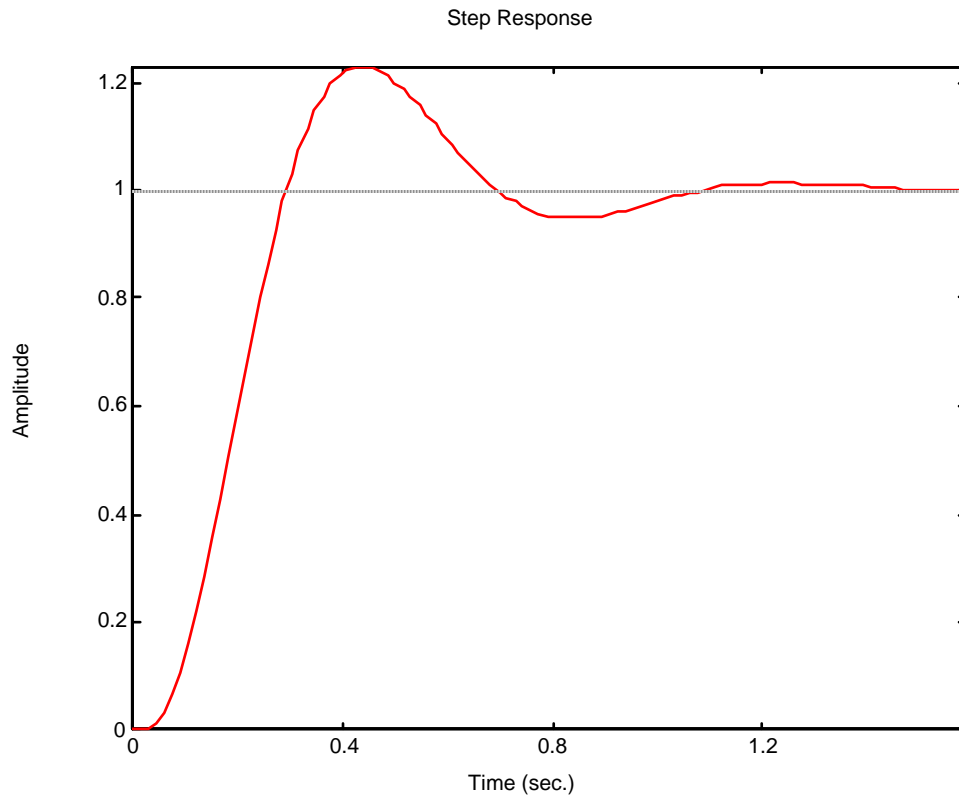

48.

a.

In chapter 4 we found that the open loop transfer function of this system is type 0. Thus for zero steady state error, integral control is required. Also as the open loop transfer function has a zero at -0.02, and this zero will appear as a zero of the closed loop transfer function if not eliminated, it will be cancelled with a closed loop pole. The 10% overshoot requirement corresponds to a  $\zeta = 0.6$  damping factor. The settling time requirement correspond to a second order term with  $\zeta\omega_n = \frac{4}{T_s} = 0.04$  or  $\omega_n = 0.0667$ . The desired closed loop polynomial is:



$$(s^2 + 0.08s + 0.0044)(s + 0.02)(s + 0.5) = s^4 + 0.6s^3 + 0.056s^2 + 0.003088s + 0.000044$$

where a far away pole was arbitrarily added at -0.5.

Following equation (12.115a) in the text, the closed loop system matrix  $\mathbf{A}$  is given by

$$\mathbf{A}_{CL} = \begin{bmatrix} \mathbf{A} - \mathbf{BK} & \mathbf{B}k_e \\ -\mathbf{C} & 0 \end{bmatrix}$$

$$= \begin{bmatrix} \begin{bmatrix} -0.04167 & 0 & -0.0058 \\ 0.0217 & -0.24 & 0.0058 \\ 0 & 100 & -2.4 \\ & & [0 \ 0 \ -1] \end{bmatrix} - \begin{bmatrix} 5.2 \\ -5.2 \\ 0 \end{bmatrix} [k_1 \ k_2 \ k_3] & \begin{bmatrix} 5.2 \\ -5.2 \\ 0 \\ 0 \end{bmatrix} k_e \end{bmatrix}$$

$$= \begin{bmatrix} -(0.04167 + 5.2k_1) & -5.2k_2 & -(0.0058 + 5.2k_3) & 5.2k_e \\ 0.0217 + 5.2k_1 & -0.24 + 5.2k_2 & 0.0058 + 5.2k_3 & -5.2k_e \\ 0 & 100 & -2.4 & 0 \\ 0 & 0 & -1 & 0 \end{bmatrix}$$

The corresponding characteristic polynomial is:

$$s^4 + (2.68167 + 5.2k_1 - 5.2k_2)s^3 + (0.1060088 + 13.728k_1 - 12.583844k_2 - 520k_3)s^2 + (0.01241932 + 2.9952k_1 - 0.2492256k_2 - 10.3844k_3 - 520k_e)s - 10.3844k_e$$

Equating the coefficients of this polynomial with those of the desired polynomial and solving simultaneous equations one gets

$$\mathbf{K} = [k_1 \ k_2 \ k_3] = [-0.004174 \ 0.39615 \ -0.0096] \text{ and } k_e = -4.237125 \times 10^{-6}$$

b.

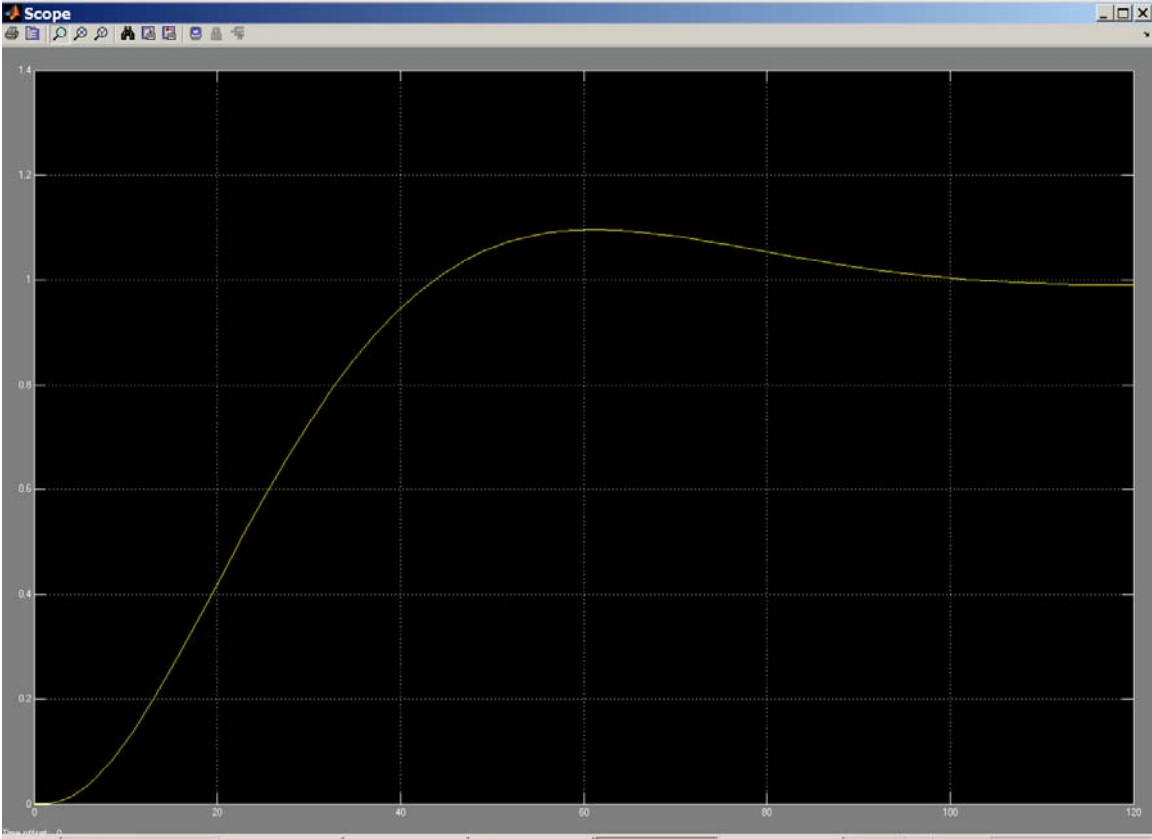
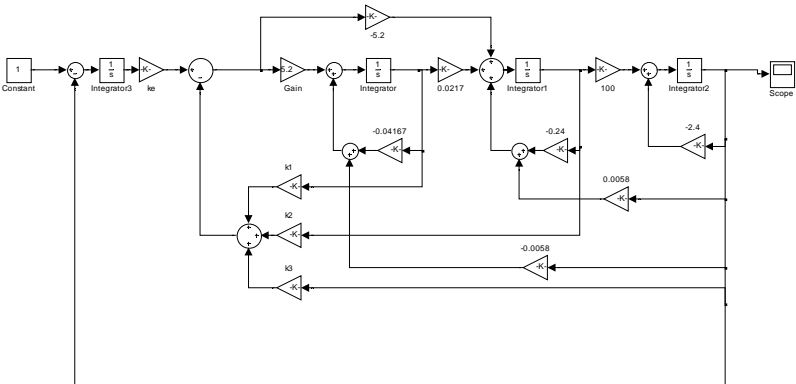

49.

We'll start by finding the key parameters needed to meet specifications:

- The damping ratio,  $\zeta$ , for a 4.32% overshoot is:

$$\zeta = \frac{-\ln(\%OS/100)}{\sqrt{\pi^2 + \ln^2(\%OS/100)}} = \frac{-\ln(4.32/100)}{\sqrt{\pi^2 + \ln^2(4.32/100)}} = 0.707$$

- The natural frequency,  $\omega_n$ , for a settling time = 4 sec at the above  $\zeta$  is:

$$T_s = \frac{4}{\zeta\omega_n} \Rightarrow 4 = \frac{4}{0.707\omega_n} \Rightarrow \omega_n = 1.414 \text{ rad/sec}$$

- The coordinates of the required dominant poles,  $-\zeta\omega_n \pm j\omega_d = -1 \pm j1$ .
- The open-loop transfer-function of the "plant" is given by equation (3.73):

$$G(s) = \frac{Y(s)}{U(s)} = \mathbf{C}(s\mathbf{I} - \mathbf{A})^{-1}\mathbf{B} + \mathbf{D}$$

Here:

$$(s\mathbf{I} - \mathbf{A}) = \begin{bmatrix} s & 0 \\ 0 & s \end{bmatrix} - \begin{bmatrix} -20 & -40 \\ 0.2491 & -0.0191 \end{bmatrix} = \begin{bmatrix} s+20 & 40 \\ -0.2491 & s+0.0191 \end{bmatrix}$$

$$(s\mathbf{I} - \mathbf{A})^{-1} = \frac{\text{adj}(s\mathbf{I} - \mathbf{A})}{\det(s\mathbf{I} - \mathbf{A})} = \frac{\text{adj} \begin{bmatrix} s+20 & 40 \\ -0.2491 & s+0.0191 \end{bmatrix}}{s^2 + 20.0191s + 10.346} = \frac{\begin{bmatrix} s+0.0191 & 0.2491 \\ -40 & s+20 \end{bmatrix}}{s^2 + 20.0191s + 10.346}$$

Hence:

$$G(s) = \frac{Y(s)}{U(s)} = \frac{\begin{bmatrix} 0 & 0.06154 \end{bmatrix} \begin{bmatrix} s+0.0191 & 0.2491 \\ -40 & s+20 \end{bmatrix} \begin{bmatrix} 0 \\ 1000 \end{bmatrix}}{s^2 + 20.0191s + 10.346} = \frac{61.54(s+20)}{s^2 + 20.0191s + 10.346}$$

Now, we write the closed-loop state equations for the system with integral control in a form similar to that given in the text by equations 12.115a and 12.115b (Figure 12.21):

$$\begin{bmatrix} \dot{I}_a \\ \dot{\omega} \\ \dot{x}_N \end{bmatrix} = \begin{bmatrix} -20 & -40 & 0 \\ 0.2491 - 1000k_1 & -0.0191 - 1000k_2 & 1000K_e \\ 0 & -0.06154 & 0 \end{bmatrix} \begin{bmatrix} I_a \\ \omega \\ x_N \end{bmatrix} + \begin{bmatrix} 0 \\ 0 \\ 1 \end{bmatrix} r$$

And the output equation is given by:  $y(t) = v(t) = \begin{bmatrix} 0 & 0.06154 & 0 \end{bmatrix} \begin{bmatrix} I_a \\ \omega \\ x_N \end{bmatrix}$

$$(s\mathbf{I} - \mathbf{A}) = \begin{bmatrix} s & 0 & 0 \\ 0 & s & 0 \\ 0 & 0 & s \end{bmatrix} - \begin{bmatrix} -20 & -40 & 0 \\ 0.2491 - 1000K_1 & -0.0191 - 1000K_2 & 1000K_e \\ 0 & -0.06154 & 0 \end{bmatrix} =$$

$$\begin{bmatrix} s + 20 & 40 & 0 \\ -0.2491 + 1000K_1 & s + 0.0191 + 1000K_2 & -1000K_e \\ 0 & 0.06154 & s \end{bmatrix}$$

The characteristic polynomial for that system is:

$$s^3 + (20.0191 + 1000K_2) s^2 + (-40000K_1 + 20000K_2 + 61.54K_e + 10.346) s + 1230.8K_e$$

The desired characteristic polynomial (with the third pole placed to cancel the zero at -20) is:

$$s^3 + 22 s^2 + 42 s + 40$$

Equating coefficients of the characteristic polynomials yields:

$$K_1 = 0.000249, K_2 = 0.001981, K_e = 0.0325.$$

Substituting these values into the state equations for the system yields:

$$\begin{bmatrix} \dot{I}_a \\ \dot{\omega} \\ \dot{x}_N \end{bmatrix} = \begin{bmatrix} -20 & -40 & 0 \\ 0.0001 & -2 & 32.5 \\ 0 & -0.06154 & 0 \end{bmatrix} \begin{bmatrix} I_a \\ \omega \\ x_N \end{bmatrix} + \begin{bmatrix} 0 \\ 0 \\ 1 \end{bmatrix} r$$

$$y(t) = v(t) = \begin{bmatrix} 0 & 0.06154 & 0 \end{bmatrix} \begin{bmatrix} I_a \\ \omega \\ x_N \end{bmatrix}$$

To check our assumptions, we use Eq. (3.73) and MATLAB to find the closed-loop transfer function of the system to be:

$$T(s) = \frac{Y(s)}{R(s)} = \frac{2s + 40}{s^3 + 22s^2 + 42s + 40} = \frac{2(s + 20)}{(s^2 + 2s + 2)(s + 20)} = \frac{2}{s^2 + 2s + 2}$$

The following MATLAB file was written to plot the step response.

```
A=[-20 -40 0; 0.0001 -2.000 32.5; 0 -0.06154 0];
B= [0; 0; 1];
C = [ 0 0.06154 0];
D = 0;
[num, den]= ss2tf(A,B,C,D,1);
T = tf(num, den);           %T is the closed-loop TF
step (T);
```

The characteristics displayed on the step response shown below indicate that the desired transient and steady-state response requirements are met.

To find, analytically, the steady-state error for a unit step input, we apply Equation (7.96) to the state equations to obtain:

$$e(\infty) = 1 + \begin{bmatrix} 0 & 0.06154 & 0 \end{bmatrix} \begin{bmatrix} -20 & -40 & 0 \\ 0.0001 & -2 & 32.5 \\ 0 & -0.06154 & 0 \end{bmatrix}^{-1} \begin{bmatrix} 0 \\ 0 \\ 1 \end{bmatrix} = 0$$

Thus, the system behaves like a Type 1 system.

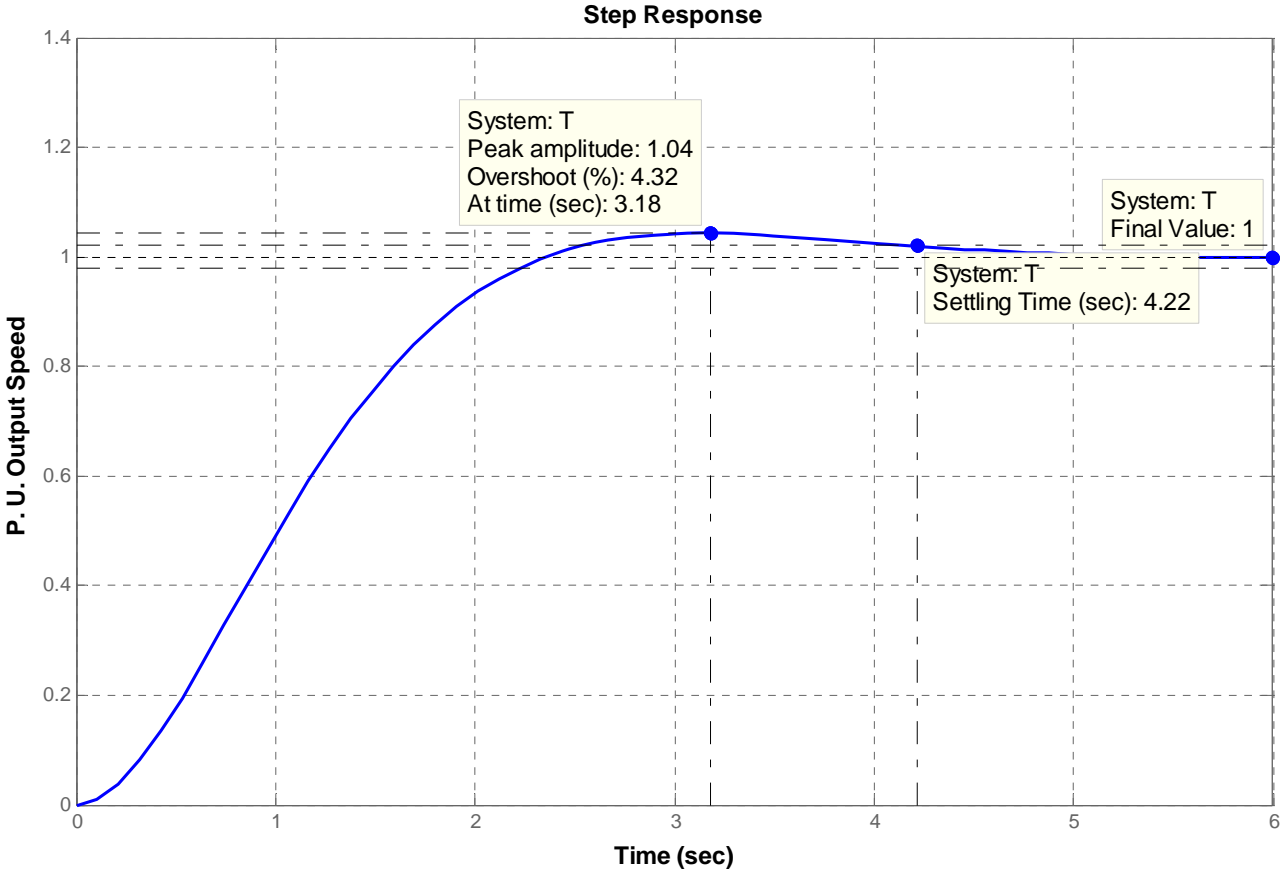

# T H I R T E E N

## Digital Control Systems

### SOLUTIONS TO CASE STUDIES CHALLENGES

#### Antenna Control: Transient Design via Gain

a. From the answer to the antenna control challenge in Chapter 5, the equivalent forward transfer function found by neglecting the dynamics of the power amplifier, replacing the pots with unity gain, and including the integration in the sample-and-hold is

$$G_c(s) = \frac{0.16K}{s^2(s+1.32)}$$

But,

$$\frac{1}{s^2(s+1.32)} = -0.57392 \frac{1}{s} + 0.57392 \frac{1}{s+1.32} + 0.75758 \frac{1}{s^2}$$

$$G_z = -0.57392 \frac{z}{z-1} + 0.57392 \frac{z}{z-e^{-1.32T}} + 0.75758 \frac{Tz}{(z-1)^2}$$

$$T = 0.1$$

$$G_z = -0.57392 \frac{z}{z-1} + 0.57392 \frac{z}{z-e^{-0.132}} + 0.75758 \frac{0.1z}{(z-1)^2}$$

$$G_z = 0.0047871 \frac{(z+0.95696)z}{(z-1)^2(z-0.87634)}$$

Thus,  $G_e(z) = 0.16K \frac{z-1}{z} G_z$ , or,

$$G_e(z) = 7.659 \times 10^{-4} K \frac{(z+0.95696)}{(z-1)(z-0.87634)}$$

b. Draw the root locus and overlay it over the  $\zeta = 0.5$  (i.e. 16.3% overshoot) curve.

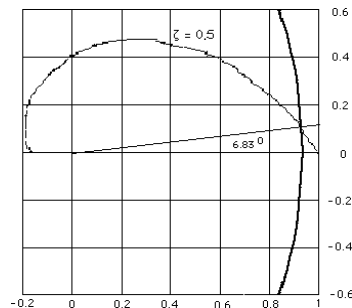

We find that the root locus crosses at approximately  $0.93 \pm j0.11$  with  $7.659 \times 10^{-4} K = 8.63 \times 10^{-3}$ .

Hence,  $K = 11.268$ .

c.

$$K_v = \frac{1}{T} \lim_{z \rightarrow 1} (z-1)G_e(z) = \frac{(7.659 \times 10^{-4} K)(1.95696)}{0.12366} = 0.1366;$$

$$e(\infty) = \frac{1}{K_v} = 7.321$$

d.

**Program:**

```
T=0.1; %Input sampling time
numf=0.16; %Numerator of F(s)
denf=[1 1.32 0 0]; %Denominator of F(s)
'F(s)' %Display label
F=tf(numf,denf) %Display F(s)
numc=conv([1 0],numf); %Differentiate F(s) to compensate
%for c2dm which assumes series zoh
denc=denf; %Denominator of continuous system
%same as denominator of F(s)
C=tf(numc,denc); %Form continuous system, C(s)
C=minreal(C,1e-10); %Cancel common poles and zeros
D=c2d(C,T,'zoh'); %Convert to z assuming zoh
'F(z)'
D=minreal(D,1e-10) %Cancel common poles and zeros and display
rlocus(D)
pos=(16.3);
z=-log(pos/100)/sqrt(pi^2+[log(pos/100)]^2);
zgrid(z,0)
title(['Root Locus with ', num2str(pos), ' Percent Overshoot Line'])
[K,p]=rlocfind(D) %Allows input by selecting point on
%graphic
```

**Computer response:**

```
ans =

F(s)

Transfer function:
      0.16
-----
s^3 + 1.32 s^2

ans =

F(z)

Transfer function:
0.0007659 z + 0.000733
-----
z^2 - 1.876 z + 0.8763

Sampling time: 0.1
Select a point in the graphics window

selected_point =

    9.2969e-001 +1.0219e-001i

K =

    9.8808e+000
```



p =

```
9.3439e-001 +1.0250e-001i
9.3439e-001 -1.0250e-001i
```

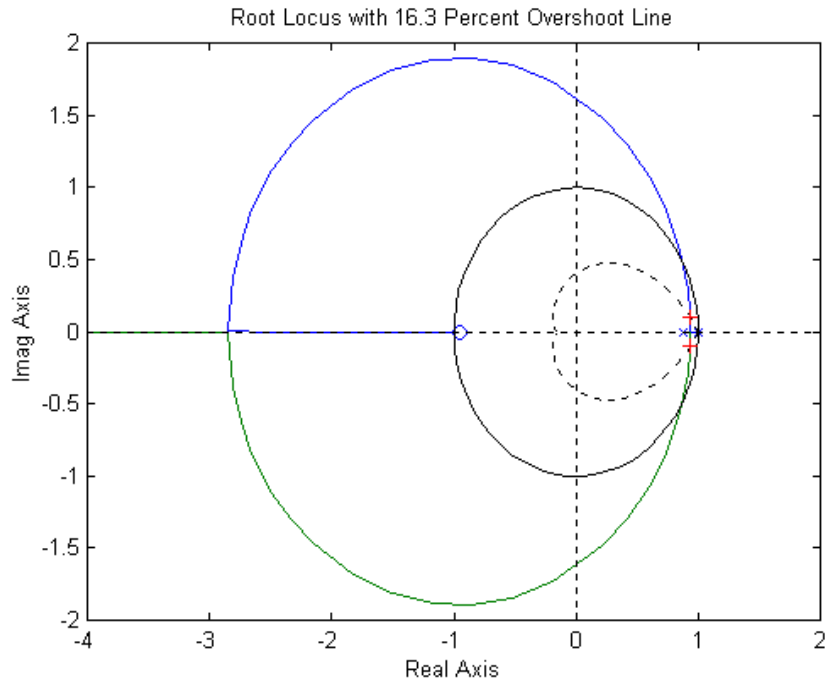

### Antenna Control: Digital Cascade Compensator Design

a. Let the compensator be  $KG_c(s)$  and the plant be  $G_p(s) = \frac{0.16}{s(s+1.32)}$ . For 10% overshoot and a

peak time of 1 second,  $\zeta = 0.591$  and  $\omega_n = 3.895$ , which places the dominant poles at  $-2.303 \pm j3.142$ . If we place the compensator zero at  $-1.32$  to cancel the plant's pole, then the following geometry results.

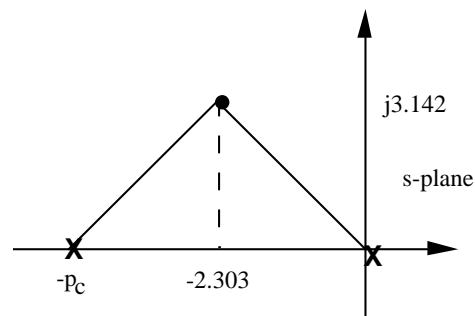

Hence,  $p_c = 4.606$ . Thus,  $G_c(s) = \frac{K(s+1.32)}{(s+4.606)}$  and  $G_c(s)G_p(s) = \frac{0.16K}{s(s+4.606)}$ . Using the

product of pole lengths to find the gain,  $0.16K = (3.896)^2$ , or  $K = 94.87$ . Hence,

$G_c(s) = \frac{94.87(s + 1.32)}{(s + 4.606)}$ . Using a sampling interval of 0.01 s, the Tustin transformation of  $G_c(s)$

$$\text{is } G_c(z) = \frac{93.35(z - 0.9869)}{(z - 0.955)} = \frac{93.35z - 92.12}{z - 0.955}.$$

**b.** Cross multiplying,

$$(z - 0.955)X(z) = (93.35z - 92.12)E(z)$$

Solving for the highest power of z operating on  $X(z)$ ,

$$zX(z) = (93.35z - 92.12)E(z) + 0.955X(z)$$

Solving for  $X(z)$ ,

$$X(z) = (93.35 - 92.12z^{-1})E(z) + 0.955z^{-1}X(z)$$

Implementing this equation as a flowchart yields the following diagram

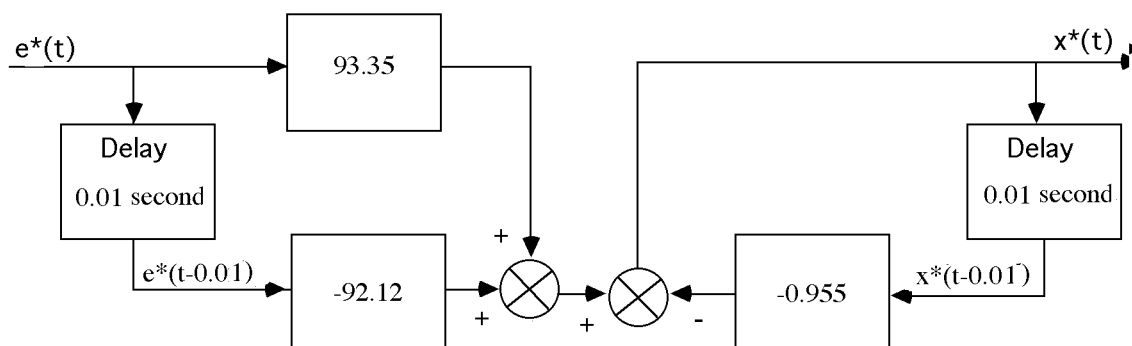

**c.**

**Program:**

```
's-plane lead design for Challenge - Lead Comp'
clf                                     %Clear graph on screen.
'Uncompensated System'                 %Display label.
numg=0.16;                             %Generate numerator of G(s).
deng=poly([0 -1.32]);                  %Generate denominator of G(s).
'G(s)'                                 %Display label.
G=tf(numg,deng);                       %Create G(s).
Gzpk=zpk(G)                            %Display G(s).
pos=input('Type desired percent overshoot '); %Input desired percent overshoot.
z=-log(pos/100)/sqrt(pi^2+[log(pos/100)]^2); %Calculate damping ratio.
Tp=input('Type Desired Peak Time '); %Input desired peak time.
wn=pi/(Tp*sqrt(1-z^2));                %Evaluate desired natural frequency.
b=input('Type Lead Compensator Zero, (s+b). b= '); %Input lead compensator zero.
done=1;                                %Set loop flag.

while done==1                          %Start loop for trying lead
    %compensator pole.
    a=input('Enter a Test Lead Compensator Pole, (s+a). a = '); %Enter test lead compensator pole.
    numge=conv(numg,[1 b]);             %Generate numerator of Gc(s)G(s).
    denge=conv([1 a],deng);            %Generate denominator of Gc(s)G(s).
    Ge=tf(numge,denge);                %Create Ge(s)=Gc(s)G(s).
    clf                                 %Clear graph on screen.
```

```

rlocus(Ge) %Plot compensated root locus with
axis([-5 2 -8 8]); %test lead compensator pole.
sgrid(z,wn) %Change axes ranges.
title(['Lead-Compensated Root Locus with ', num2str(pos),...
'% Overshoot Line, Lead Pole at ', num2str(-a),...
' and Required Wn']) %Overlay grid on lead-compensated
%root locus.
done=input('Are you done? (y=0,n=1) ');
end %Set loop flag.
[K,p]=rlocfind(Ge); %End loop for trying compensator
%pole.
'Gc(s)' %Generate gain, K, and closed-loop
Gc=K*tf([1 b],[1 a]) %poles, p, for point selected
'Gc(s)G(s)' %interactively on the root locus.
Ge %Display label.
'Closed-loop poles = ' %Display lead compensator.
p %Display label.
f=input('Give pole number that is operating point '); %Display Gc(s)G(s).
'Summary of estimated specifications for selected point on lead' %Display label.
'compensated root locus' %Display lead-compensated dominant
operatingpoint=p(f) %pole.
gain=K %Display lead-compensated gain.
estimated_settling_time=4/abs(real(p(f))) %Display lead-compensated settling
%time.
estimated_peak_time=pi/abs(imag(p(f))) %Display lead-compensated peak time.
estimated_percent_overshoot=pos %Display lead-compensated percent
%overshoot.
estimated_damping_ratio=z %Display lead-compensated damping
%ratio.
estimated_natural_frequency=sqrt(real(p(f))^2+imag(p(f))^2) %Display lead-compensated natural
%frequency.
s=tf([1 0],1); %Create transfer function, "s".
sGe=s*Ge; %Create sGe(s) to evaluate Kv.
sGe=minreal(sGe); %Cancel common poles and zeros.
Kv=dcgain(K*sGe) %Display lead-compensated Kv.
ess=1/Kv %Display lead-compensated steady-
%state error for unit ramp input.
'T(s)' %Display label.
T=feedback(K*Ge,1) %Create and display lead-compensated
%T(s).
'Press any key to continue and obtain the lead-compensated step'
'response' %Display label
pause
step(T) %Plot step response for lead
%compensated system.
title(['Lead-Compensated System with ', num2str(pos), '% Overshoot'])
%Add title to step response of PD
%compensated system.
pause
'z-plane conversion for Challenge - Lead Comp'
clf %Clear graph.
'Gc(s) in polynomial form' %Print label.
Gcs=Gc %Create Gc(s) in polynomial form.
'Gc(s) in polynomial form' %Print label.

```

```

Gcszpk=zpk(Gcs) %Create Gc(s) in factored form.
'Gc(z) in polynomial form via Tustin Transformation'
%Print label.
Gcz=c2d(Gcs,1/100,'tustin') %Form Gc(z) via Tustin
%transformation.
'Gc(z) in factored form via Tustin Transformation'
%Print label.
Gczzpk=zpk(Gcz) %Show Gc(z) in factored form.
'Gp(s) in polynomial form' %Print label.
Gps=G %Create Gp(s) in polynomial form.
'Gp(s) in factored form' %Print label.
Gpszpk=zpk(Gps) %Create Gp(s) in factored form.
'Gp(z) in polynomial form' %Print label.
Gpz=c2d(Gps,1/100,'zoh') %Form Gp(z) via zoh transformation.
'Gp(z) in factored form' %Print label.
Gpzzpk=zpk(Gpz) %Form Gp(z) in factored form.
pole(Gpz) %Find poles.
Gez=Gcz*Gpz; %Form Ge(z) = Gc(z)Gp(z).
'Ge(z) = Gc(z)Gp(z) in factored form'
%Print label.
Gezzpk=zpk(Gez) %Form Ge(z) in factored form.
'z-1' %Print label.
zml=tf([1 -1],1,1/100) %Form z-1.
zmlGez=minreal(zml*Gez,.00001);
'(z-1)Ge(z)' %Print label.
zmlGezzpk=zpk(zmlGez)
pole(zmlGez)
Kv=300*dcgain(zmlGez)
Tz=feedback(Gez,1)
step(Tz)
title('Closed-Loop Digital Step Response')
%Add title to step response.

```

**Computer response:**

ans =

s-plane lead design for Challenge - Lead Comp

ans =

Uncompensated System

ans =

G(s)

Zero/pole/gain:

0.16

-----  
s (s+1.32)

Type desired percent overshoot 10

Type Desired Peak Time 1

Type Lead Compensator Zero, (s+b). b= 1.32

Enter a Test Lead Compensator Pole, (s+a). a = 4.606

Are you done? (y=0,n=1) 0

Select a point in the graphics window

selected\_point =

-2.3045 + 3.1056i

ans =

$G_c(s)$

Transfer function:

$$\frac{93.43 s + 123.3}{s + 4.606}$$

ans =

$G_c(s)G(s)$

Transfer function:

$$\frac{0.16 s + 0.2112}{s^3 + 5.926 s^2 + 6.08 s}$$

ans =

Closed-loop poles =

p =

$$\begin{aligned} & -2.3030 + 3.1056i \\ & -2.3030 - 3.1056i \\ & -1.3200 \end{aligned}$$

Give pole number that is operating point 1

ans =

Summary of estimated specifications for selected point on lead

ans =

compensated root locus

operatingpoint =

$$-2.3030 + 3.1056i$$

gain =

$$93.4281$$

estimated\_settling\_time =

$$1.7369$$

estimated\_peak\_time =

$$1.0116$$

estimated\_percent\_overshoot =

$$10$$

13-8 Chapter 13: Digital Control Systems

estimated\_damping\_ratio =

0.5912

estimated\_natural\_frequency =

3.8663

Kv =

3.2454

ess =

0.3081

ans =

T(s)

Transfer function:

14.95 s + 19.73

-----  
s^3 + 5.926 s^2 + 21.03 s + 19.73

ans =

Press any key to continue and obtain the lead-compensated step

ans =

response

ans =

z-plane conversion for Challenge - Lead Comp

ans =

Gc(s) in polynomial form

Transfer function:

93.43 s + 123.3

-----  
s + 4.606

ans =

Gc(s) in polynomial form

Zero/pole/gain:

93.4281 (s+1.32)

-----

(s+4.606)

ans =

Gc(z) in polynomial form via Tustin Transformation

Transfer function:  

$$\frac{91.93 z - 90.72}{z - 0.955}$$

Sampling time: 0.01

ans =

Gc(z) in factored form via Tustin Transformation

Zero/pole/gain:  

$$91.9277 (z-0.9869)$$

$$(z-0.955)$$

Sampling time: 0.01

ans =

Gp(s) in polynomial form

Transfer function:  

$$\frac{0.16}{s^2 + 1.32 s}$$

ans =

Gp(s) in factored form

Zero/pole/gain:  

$$0.16$$

$$s (s+1.32)$$

ans =

Gp(z) in polynomial form

Transfer function:  

$$\frac{7.965e-006 z + 7.93e-006}{z^2 - 1.987 z + 0.9869}$$

Sampling time: 0.01

ans =

Gp(z) in factored form

Zero/pole/gain:

13-10 Chapter 13: Digital Control Systems

$$\frac{7.9649e-006 (z+0.9956)}{(z-1) (z-0.9869)}$$

Sampling time: 0.01

ans =

$$\begin{matrix} 1.0000 \\ 0.9869 \end{matrix}$$

ans =

Ge(z) = Gc(z)Gp(z) in factored form

Zero/pole/gain:

$$\frac{0.0007322 (z+0.9956) (z-0.9869)}{(z-1) (z-0.9869) (z-0.955)}$$

Sampling time: 0.01

ans =

$$z-1$$

Transfer function:  
z - 1

Sampling time: 0.01

ans =

$$(z-1)Ge(z)$$

Zero/pole/gain:

$$\frac{0.0007322 (z+0.9956)}{(z-0.955)}$$

Sampling time: 0.01

ans =

$$0.9550$$

Kv =

$$9.7362$$

Transfer function:

$$\frac{0.0007322 z^2 + 6.387e-006 z - 0.0007194}{z^3 - 2.941 z^2 + 2.884 z - 0.9432}$$

Sampling time: 0.01



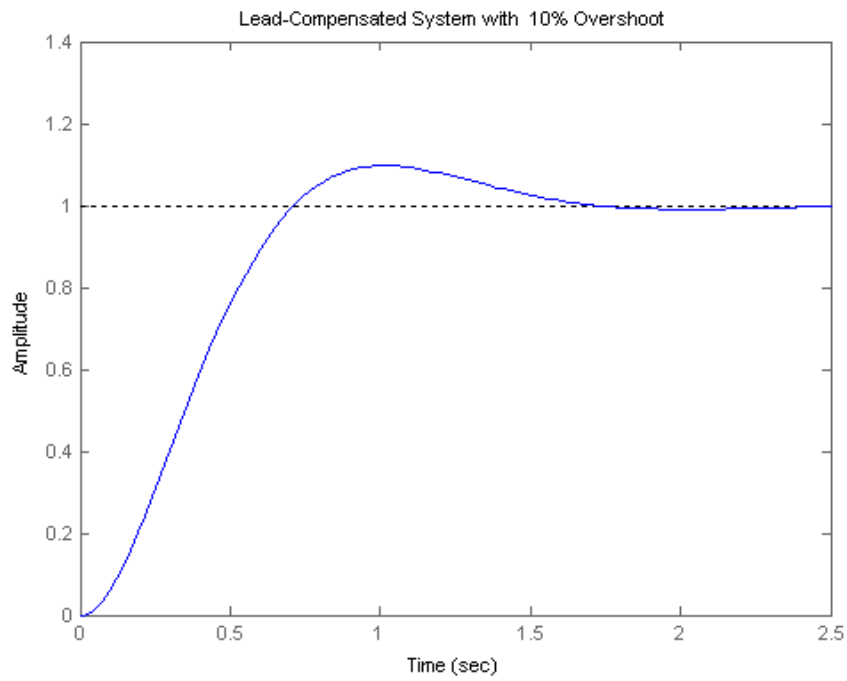
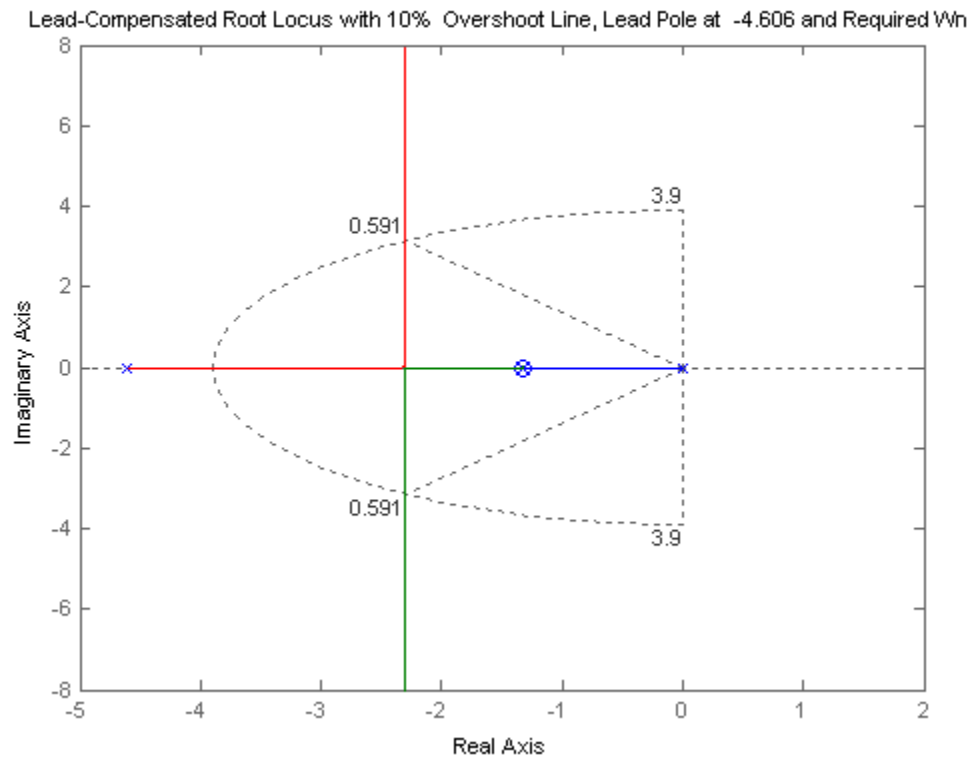

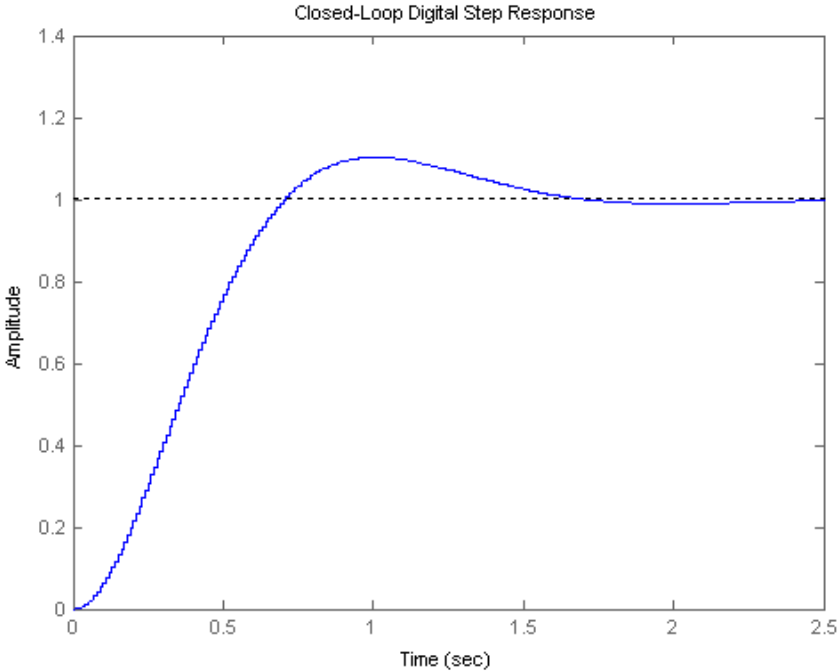

## ANSWERS TO REVIEW QUESTIONS

1. (1) Supervisory functions external to the loop; (2) controller functions in the loop
2. (1) Control of multiple loops by the same hardware; (2) modifications made with software, not hardware; (3) more noise immunity (4) large gains usually not required
3. Quantization error; conversion time
4. An ideal sampler followed by a sample-and-hold
5.  $z = e^{sT}$
6. The value of the time waveform only at the sampling instants
7. Partial fraction expansion; division to yield power series
8. Partial fraction
9. Division to yield power series
10. The input must be sampled; the output must be either sampled or thought of as sampled.
11.  $c(t)$  is  $c^*(t) = c(kT)$ , i.e. the output only at the sampling instants.
12. No; the waveform is only valid at the sampling instants. Instability may be apparent if one could only see between the sampling instants. The roots of the denominator of  $G(z)$  must be checked to see that they are within the unit circle.
13. A sample-and-hold must be present between the cascaded systems.
14. Inside the unit circle
15. Raible table; Jury's stability test
16.  $z=+1$
17. There is no difference.
18. Map the point back to the  $s$ -plane. Since  $z = e^{sT}$ ,  $s = (1/T) \ln z$ . Thus,  $\sigma = (1/T) \ln (\text{Re } z)$ , and  $\omega = (1/T) \ln (\text{Im } z)$ .
19. Determine the point on the  $s$ -plane and use  $z = e^{sT}$ . Thus,  $\text{Re } z = e^{\sigma T} \cos \omega$ , and  $\text{Im } z = e^{\sigma T} \sin \omega$ .
20. Use the techniques described in Chapters 9 and 11 and then convert the design to a digital compensator using the Tustin transformation.
21. Both compensators yield the same output at the sampling instants.

## SOLUTIONS TO PROBLEMS

1.

$$\mathbf{a.} \quad f(t) = e^{-at}; f^*(t) = \sum_{k=0}^{\infty} e^{-akT} \delta(t-kT); F^*(s) = \sum_{k=0}^{\infty} e^{-akT} e^{-kTs} = 1 + e^{-aT} e^{-Ts} + e^{-2T} e^{-2Ts} + \dots \text{ Thus,}$$

$$F(z) = 1 + e^{-aT} z^{-1} + e^{-2T} z^{-2} + \dots = 1 + x^{-1} + x^{-2} + \dots \text{ where } x = e^{-aT} z^{-1}.$$

$$\text{But, } F(z) = \frac{1}{1 - x^{-1}} = \frac{1}{1 - e^{-aT} z^{-1}} = \frac{z}{z - e^{-aT}}.$$

$$\mathbf{b.} \quad f(t) = u(t); f^*(t) = \sum_{k=0}^{\infty} \delta(t-kT); F^*(s) = \sum_{k=0}^{\infty} e^{-kTs} = 1 + e^{-Ts} + e^{-2Ts} + \dots$$

$$\text{Thus, } F(z) = 1 + z^{-1} + z^{-2} + \dots \text{ Since } \frac{1}{1 - z^{-1}} = 1 + z^{-1} + z^{-2} + z^{-3} + \dots, F(z) = \sum_{k=0}^{\infty} z^{-k} = \frac{1}{1 - z^{-1}} = \frac{z}{z - 1}.$$

$$\mathbf{c.} \quad f(t) = t^2 e^{-at}; f^*(t) = \sum_{k=0}^{\infty} (kT)^2 e^{-akT} \delta(t-kT); F^*(s) = T^2 \sum_{k=0}^{\infty} k^2 e^{-akT} e^{-kTs}$$

$$= T^2 \sum_{k=0}^{\infty} k^2 (e^{-(s+a)T})^k = T^2 \sum_{k=0}^{\infty} k^2 x^k = T^2 (x + 4x^2 + 9x^3 + 16x^4 + \dots), \text{ where } x = e^{-(s+a)T}.$$

$$\text{Let } s_1 = x + 4x^2 + 9x^3 + 16x^4 + \dots \text{ Thus, } xs_1 = x^2 + 4x^3 + 9x^4 + 16x^5 + \dots$$

$$\text{Let } s_2 = s_1 - xs_1 = x + 3x^2 + 5x^3 + 7x^4 + \dots \text{ Thus, } xs_2 = x^2 + 4x^3 + 9x^4 + 16x^5 + \dots$$

$$\text{Let } s_3 = s_2 - xs_2 = x + 2x^2 + 2x^3 + 2x^4 + \dots \text{ Thus } xs_3 = x^2 + 2x^3 + 2x^4 + 2x^5 + \dots$$

$$\text{Let } s_4 = s_3 - xs_3 = x + x^2.$$

Solving for  $s_3$ ,

$$s_3 = \frac{x + x^2}{1 - x}$$

and

$$s_2 = \frac{s_3}{1 - x} = \frac{x + x^2}{(1 - x)^2}$$

and

$$s_1 = \frac{s_2}{1 - x} = \frac{x + x^2}{(1 - x)^3}$$

Thus

$$F^*(s) = T^2 s_1 = T^2 \frac{x + x^2}{(1 - x)^3} = T^2 \frac{(e^{-(s+a)T} + e^{-2(s+a)T})}{(1 - e^{-(s+a)T})^3} =$$

$$\frac{T^2[z^{-1}e^{-aT} + z^{-2}e^{-2aT}]}{z^{-3}(z - e^{-aT})^3} = \frac{T^2ze^{-aT}[z + e^{-aT}]}{(z - e^{-aT})^3}$$

$$\begin{aligned} \text{d. } f(t) &= \cos(\omega kT); f^*(t) = \sum_{k=0}^{\infty} \cos(\omega kT) \delta(t - kT); F^*(s) = \sum_{k=0}^{\infty} \cos(\omega kT) e^{-kTs} \\ &= \sum_{k=0}^{\infty} \frac{(e^{j\omega kT} + e^{-j\omega kT})e^{-kTs}}{2} = \frac{1}{2} \sum_{k=0}^{\infty} (e^{T(s-j\omega)})^{-k} + (e^{T(s+j\omega)})^{-k} \end{aligned}$$

But,

$$\sum_{k=0}^{\infty} x^{-k} = \frac{1}{1 - x^{-1}}.$$

Thus,

$$\begin{aligned} F^*(s) &= \frac{1}{2} \left[ \frac{1}{1 - e^{-T(s-j\omega)}} + \frac{1}{1 - e^{-T(s+j\omega)}} \right] = \frac{1}{2} \left[ \frac{2 - e^{-Ts}(e^{j\omega T} + e^{-j\omega T})}{1 - e^{-T(s-j\omega)} - e^{-T(s+j\omega)} + e^{-T(s-j\omega)}e^{-T(s+j\omega)}} \right] \\ &= \frac{1}{2} \left[ \frac{2 - e^{-Ts}(2 \cos(\omega T))}{1 - e^{-Ts}(e^{j\omega T} + e^{-j\omega T}) + e^{-2Ts}} \right] = \frac{1 - z^{-1} \cos(\omega T)}{1 - 2z^{-1} \cos(\omega T) + z^{-2}} \end{aligned}$$

Therefore,

$$F(z) = \frac{z(z - \cos(\omega T))}{z^2 - 2z \cos(\omega T) + 1}$$

2.

**Program:**

```

syms T a w n                                %Construct symbolic objects for
                                              %'T', 'a', 'w', and 'n'.
'a)'                                         %Display label.
'f(kT)'                                       %Display label.
f=exp(-a*n*T);                               %Define f(kT).
pretty(f)                                     %Pretty print f(kT)
'F(z)'                                       %Display label.
F=ztrans(f);                                 %Find z-transform, F(z).
pretty(F)                                     %Pretty print F(z).

' (b) '                                       %Display label.
'f(kT)'                                       %Display label.
f=exp(-0*n*T);                               %Define f(kT)
pretty(f)                                     %Pretty print f(kT)
'F(z)'                                       %Display label.
F=ztrans(f);                                 %Find z-transform, F(z).
pretty(F)                                     %Pretty print F(z).

' (c) '                                       %Display label.
'f(kT)'                                       %Display label.
f=(n*T)^2*exp(-a*n*T);                       %Define f(kT)
pretty(f)                                     %Pretty print f(kT)
'F(z)'                                       %Display label.
F=ztrans(f);                                 %Find z-transform, F(z).
pretty(F)                                     %Pretty print F(z).

' (d) '                                       %Display label.
'f(kT)'                                       %Display label.
f=cos(w*n*T);                               %Define f(kT)
pretty(f)                                     %Pretty print f(kT)
'F(z)'                                       %Display label.

```

13-16 Chapter 13: Digital Control Systems

```
F=ztrans(f); %Find z-transform, F(z).
pretty(F) %Pretty print F(z).
```

**Computer response:**

ans =

(a)

ans =

f(kT)

$$\exp(-a n T)$$

ans =

F(z)

$$\frac{z}{\exp(-a T) \left( \frac{z}{\exp(-a T)} - 1 \right)}$$

ans =

(b)

ans =

f(kT)

$$1$$

ans =

F(z)

$$\frac{z}{z - 1}$$

ans =

(c)

ans =

f(kT)

$$n^2 \exp(-a n T)$$

ans =

F(z)

$$\frac{T^2 z \exp(-a T) (z + \exp(-a T))}{(z - \exp(-a T))^3}$$

ans =

(d)

ans =

$f(kT)$

$$\cos(\omega n T)$$

ans =

$F(z)$

$$\frac{(z - \cos(\omega T)) z}{z^2 - 2z \cos(\omega T) + 1}$$

3.

a.

$$F(z) = \frac{z(z+3)(z+5)}{(z-0.4)(z-0.6)(z-0.8)}$$

$$\frac{F(z)}{z} = \frac{229.5}{z-0.4} - \frac{504}{z-0.6} + \frac{275.5}{z-0.8}$$

$$F(z) = \frac{229.5z}{z-0.4} - \frac{504z}{z-0.6} + \frac{275.5z}{z-0.8}$$

$$f(kT) = 229.5(0.4)^k - 504(0.6)^k + 275.5(0.8)^k, \quad k = 0, 1, 2, 3, \dots$$

b.

$$F(z) = \frac{(z+0.2)(z+0.4)}{(z-0.1)(z-0.5)(z-0.9)}$$

$$\frac{F(z)}{z} = -\frac{1.778}{z} + \frac{4.6875}{z-0.1} - \frac{7.875}{z-0.5} + \frac{4.9653}{z-0.9}$$

$$F(z) = -1.778z + \frac{4.6875z}{z-0.1} - \frac{7.875z}{z-0.5} + \frac{4.9653z}{z-0.9}$$

$$f(kT) = 4.6875(0.1)^k - 7.875(0.5)^k + 4.9653(0.9)^k, \quad k = 1, 2, 3, \dots$$

c.

$$F(z) = \frac{(z+1)(z+0.3)(z+0.4)}{z(z-0.2)(z-0.5)(z-0.7)}$$

$$\frac{F(z)}{z} = \frac{(z+1)(z+0.3)(z+0.4)}{z^2(z-0.2)(z-0.5)(z-0.7)}$$

$$= \frac{38.1633}{z-0.7} - \frac{72}{z-0.5} + \frac{60}{z-0.2} - \frac{26.1633}{z} - \frac{1.7143}{z^2}$$

$$F(z) = \frac{38.1633z}{z-0.7} - \frac{72z}{z-0.5} + \frac{60z}{z-0.2} - 26.1633 - \frac{1.7143}{z}$$

$$F = 38.1633(0.7)^k - 72(0.5)^k + 60(0.2)^k \quad \text{for } k = 2, 3, 4, \dots$$

$$= 1 \quad \text{for } k = 1$$

$$= 0 \quad \text{for } k = 0$$

4.

**Program:**

```
'(a)'  
syms z k  
F=vpa(z*(z+3)*(z+5)/((z-0.4)*(z-0.6)*(z-0.8)),4);  
pretty(F)  
f=vpa(iztrans(F),4);  
pretty(f)  
'(b)'  
syms z k  
F=vpa((z+0.2)*(z+0.4)/((z-0.1)*(z-0.5)*(z-0.9)),4);  
pretty(F)  
f=vpa(iztrans(F),4);  
pretty(f)  
'(c)'  
syms z k  
F=vpa((z+1)*(z+0.3)*(z+0.4)/(z*(z-0.2)*(z-0.5)*(z-0.7)),4);  
pretty(F)  
f=vpa(iztrans(F),4);  
pretty(f)
```

**Computer response:**

ans =

(a)

$$\frac{z(z+3)(z+5)}{(z-0.4000)(z-0.6000)(z-0.8000)}$$

$$275.5 \cdot 0.8000^n - 504.0 \cdot 0.6000^n + 229.5 \cdot 0.4000^n$$

ans =

(b)

$$\frac{(z+0.2000)(z+0.4000)}{(z-0.1000)(z-0.5000)(z-0.9000)}$$

n n n



$$-1.778 \text{ charfcn}[0](n) + 4.965 \cdot .9000 - 7.875 \cdot .5000 + 4.688 \cdot .1000$$

ans =

(c)

$$\frac{(z + 1.) (z + .3000) (z + .4000)}{z (z - .2000) (z - .5000) (z - .7000)}$$

$$-1.714 \text{ charfcn}[1](n) - 26.16 \text{ charfcn}[0](n) + 38.16 \cdot .7000^n - 72.00 \cdot .5000^n + 60.00 \cdot .2000^n$$

5.

a.

Instant	By division		By Formula	
	Value	k	Value	k
0		1	0	1
1		9.8	1	9.8
2		31.6	2	31.6
3		46.88	3	46.88
4		53.4016	4	53.4016
5		53.43488	5	53.43488
6		49.64608	6	49.64608
7		44.043776	7	44.043776
8		37.90637056	8	37.90637056
9		31.95798733	9	31.95798733
10		26.5581568	10	26.5581568
11		21.84639857	11	21.84639857
12		17.83896791	12	17.83896791
13		14.48905384	13	14.48905384
14		11.72227881	14	11.72227881
15		9.456567702	15	9.456567702
16		7.612550239	16	7.612550239
17		6.118437551	17	6.118437551
18		4.911796342	18	4.911796342
19		3.939668009	19	3.939668009
20		3.15787423	20	3.15787423
21		2.529983782	21	2.529983782
22		2.026197867	22	2.026197867
23		1.622284879	23	1.622284879
24		1.298623886	24	1.298623886
25		1.039376712	25	1.039376712
26		0.831787937	26	0.831787937
27		0.665602292	27	0.665602292
28		0.532584999	28	0.532584999
29		0.4261299	29	0.4261299
30		0.34094106	30	0.34094106

**b.**

Instant	By division		By Formula	
	Value	k	k	Value
1		1	1	1.00002
2		2.1	2	2.100018
3		2.64	3	2.6400162
4		2.766	4	2.76601458
5		2.6859	5	2.685913122
6		2.51571	6	2.51572181
7		2.313354	7	2.313364629
8		2.1066276	8	2.106637166
9		1.90826949	9	1.908278099
10		1.723594881	10	1.723602629
11		1.554311564	11	1.554318538
12		1.400418494	12	1.40042477
13		1.261145687	13	1.261151336
14		1.13541564	14	1.135420724
15		1.022066337	15	1.022070912
16		0.919955834	16	0.919959951
17		0.828008315	17	0.828012021
18		0.745231516	18	0.745234852
19		0.670720381	19	0.670723383
20		0.603654351	20	0.603657053
21		0.54329192	21	0.543294352
22		0.48896423	22	0.488966419
23		0.440068558	23	0.440070528
24		0.396062078	24	0.39606385
25		0.356456058	25	0.356457653
26		0.320810546	26	0.320811982
27		0.288729538	27	0.28873083
28		0.259856608	28	0.259857771
29		0.233870959	29	0.233872006
30		0.210483869	30	0.210484811
31		0.189435485	31	0.189436333

c.

Instant	via Division	via Closed Form Expression
0		0
1	1	1
2	3.1	3.100017
3	4.57	4.5700119
4	4.759	4.75900833
5	4.1833	4.183305831
6	3.36871	3.368714082
7	2.581177	2.581179857
8	1.9189399	1.9189419
9	1.39943113	1.39943253
10	1.007711431	1.007712411
11	0.71945743	0.719458116
12	0.510650836	0.510651317
13	0.360971088	0.360971424
14	0.254437549	0.254437785
15	0.178985186	0.178985351
16	0.125729082	0.125729198
17	0.088230084	0.088230165
18	0.061870922	0.061870978
19	0.043364577	0.043364617
20	0.03038267	0.030382697
21	0.021281602	0.021281621
22	0.014903988	0.014904001
23	0.010436225	0.010436234
24	0.007307074	0.00730708

6.

a.

$$G(s) = \frac{(s+4)}{(s+2)(s+5)} = \frac{0.6667}{s+2} + \frac{0.3333}{s+5}$$

$$G(z) = \frac{0.6667z}{z - e^{-2T}} + \frac{0.3333z}{z - e^{-5T}}$$

For  $T = 0.5$  s,

$$G(z) = \frac{0.6667z}{z - 0.3679} + \frac{0.3333z}{z - 0.082085} = \frac{z(z - 0.1774)}{(z - 0.3679)(z - 0.082085)}$$

b.

$$G(s) = \frac{(s+1)(s+2)}{s(s+3)(s+4)} = \frac{0.1667}{s} - \frac{0.6667}{s+3} + \frac{1.5}{s+4}$$

$$G(z) = \frac{0.1667z}{z-1} - \frac{0.6667z}{z - e^{-3T}} + \frac{1.5z}{z - e^{-4T}}$$

For  $T = 0.5$  s,

$$G(z) = \frac{0.1667z}{z-1} - \frac{0.6667z}{z-0.22313} + \frac{1.5z}{z-0.13534} = \frac{z(z-0.29675)(z-0.8408)}{(z-1)(z-0.22313)(z-0.13534)}$$

c.

$$G(s) = \frac{20}{(s+3)(s^2+6s+25)} = \frac{1.25}{s+3} - \frac{1.25s+3.57}{s^2+6s+25} = \frac{1.25}{s+3} - \frac{1.25(s+3)}{(s+3)^2+4^2}$$

$$G(z) = -1.25 \frac{z}{z-e^{-aT}} - 1.25 \frac{z^2 - zae^{-aT} \cos \omega T}{z^2 - 2ze^{-aT} \cos \omega T + e^{-2aT}}$$

For  $a=3$ ;  $\omega=4$ ;  $T=0.5$ ,

$$\begin{aligned} G(z) &= -1.25 \frac{z}{z-0.2231} - 1.25 \frac{z^2 + 0.0929z}{z^2 + 0.1857z + 0.0498} \\ &= 0.395 \frac{z(z+0.2232)}{(z-0.2231)(z^2+0.1857z+0.0498)} \end{aligned}$$

d.

$$\begin{aligned} G(s) &= \frac{15}{s(s+1)(s^2+10s+81)} = \frac{0.1852}{s} - \frac{0.2083}{s+1} + 0.02314 \frac{s+0.9978}{s^2+10s+81} \\ &= \frac{0.1852}{s} - \frac{0.2083}{s+1} + 0.02314 \frac{(s+5) - 0.5348\sqrt{56}}{(s+5)^2+56} \end{aligned}$$

$$G(z) = 0.1852 \frac{z}{z-1} - 0.2083 \frac{z}{z-e^{\beta T}} + 0.02314 \frac{z^2 - zae^{-aT} \cos \omega T}{z^2 - 2ze^{-aT} \cos \omega T + e^{-2aT}} - 0.0124 \frac{ze^{-aT} \sin \omega T}{z^2 - 2ze^{-aT} \cos \omega T + e^{-2aT}}$$

For  $a=5$ ;  $\beta=1$ ;  $\omega=\sqrt{56}$ ;  $T=0.5$ ,

$$G(z) = 0.1852 \frac{z}{z-1} - 0.2083 \frac{z}{z-0.6065} + 0.02314 \frac{z^2 + 0.0678z}{z^2 + 0.1355z + 0.006738} + 0.0005748 \frac{z}{z^2 + 0.1355z + 0.006738}$$

$$= \frac{0.00004z^4 + 0.05781z^3 + 0.02344z^2 + 0.001946z}{(z-1)(z-0.6065)(z^2 + 0.1355z + 0.006738)} \approx \frac{0.05781z^3 + 0.02344z^2 + 0.001946z}{(z-1)(z-0.6065)(z^2 + 0.1355z + 0.006738)}$$

$$= 0.05781 \frac{z^3 + 0.4055z^2 + 0.0337z}{(z-1)(z-0.6065)(z^2 + 0.1355z + 0.006738)} = 0.05781 \frac{z(z+0.2888)(z+0.1167)}{(z-1)(z-0.6065)(z^2 + 0.1355z + 0.006738)}$$

7.

**Program:**

```
'(a)'  
syms s z n T %Construct symbolic objects for  
 %'s', 'z', 'n', and 'T'.  
Gs=(s+4)/((s+2)*(s+5)); %Form G(s).  
'G(s)' %Display label.  
pretty(Gs) %Pretty print G(s).  
'g(t)' %Display label.  
gt=ilaplace(Gs); %Find g(t).  
%pretty(gt) %Pretty print g(t).  
gnT=compose(gt,n*T); %Find g(nT).  
'g(kT)' %Display label.  
%pretty(gnT) %Pretty print g(nT).
```

```

Gz=ztrans(gnT); %Find G(z).
Gz=simplify(Gz); %Simplify G(z).
%'G(z)' %Display label.
%pretty(Gz) %Pretty print G(z).
Gz=subs(Gz,T,0.5); %Let T = 0.5 in G(z).
Gz=vpa(simplify(Gz),6); %Simplify G(z) and evaluate numerical
 %values to 6 places.

Gz=vpa(factor(Gz),6); %Factor G(z).

'G(z) evaluated for T=0.5' %Display label.
pretty(Gz) %Pretty print G(z) with numerical
 %values.

'(b)'
Gs=(s+1)*(s+2)/(s*(s+3)*(s+4)); %Form G(s) = G(s).
%'G(s)' %Display label.
pretty(Gs) %Pretty print G(s).
%'g(t)' %Display label.
gt=ilaplace(Gs); %Find g(t).
%pretty(gt) %Pretty print g(t).
gnT=compose(gt,n*T); %Find g(nT).
%'g(kT)' %Display label.
%pretty(gnT) %Pretty print g(nT).
Gz=ztrans(gnT); %Find G(z).
Gz=simplify(Gz); %Simplify G(z).
%'G(z)' %Display label.
%pretty(Gz) %Pretty print G(z).
Gz=subs(Gz,T,0.5); %Let T = 0.5 in G(z).
Gz=vpa(simplify(Gz),6); %Simplify G(z) and evaluate numerical
 %values to 6 places.

Gz=vpa(factor(Gz),6); %Factor G(z).
'G(z) evaluated for T=0.5' %Display label.
pretty(Gz) %Pretty print G(z) with numerical
 %values.

'(c)'
Gs=20/((s+3)*(s^2+6*s+25)); %Form G(s) = G(s).
%'G(s)' %Display label.
pretty(Gs) %Pretty print G(s).
%'g(t)' %Display label.
gt=ilaplace(Gs); %Find g(t).
%pretty(gt) %Pretty print g(t).
gnT=compose(gt,n*T); %Find g(nT).
%'g(kT)' %Display label.
%pretty(gnT) %Pretty print g(nT).
Gz=ztrans(gnT); %Find G(z).
Gz=simplify(Gz); %Simplify G(z).
%'G(z)' %Display label.
%pretty(Gz) %Pretty print G(z).
Gz=subs(Gz,T,0.5); %Let T = 0.5 in G(z).
Gz=vpa(simplify(Gz),6); %Simplify G(z) and evaluate numerical
 %values to 6 places.

Gz=vpa(factor(Gz),6); %Factor G(z).
'G(z) evaluated for T=0.5' %Display label.
pretty(Gz) %Pretty print G(z) with numerical
 %values.

'(d)'
Gs=15/(s*(s+1)*(s^2+10*s+81)); %Form G(s) = G(s).
%'G(s)' %Display label.
pretty(Gs) %Pretty print G(s).
%'g(t)' %Display label.
gt=ilaplace(Gs); %Find g(t).
%pretty(gt) %Pretty print g(t).
gnT=compose(gt,n*T); %Find g(nT).
%'g(kT)' %Display label.
%pretty(gnT) %Pretty print g(nT).
Gz=ztrans(gnT); %Find G(z).

```

```
Gz=simplify(Gz);           %Simplify G(z).
%'G(z)'                  %Display label.
%pretty(Gz)              %Pretty print G(z).
Gz=subs(Gz,T,0.5);       %Let T = 0.5 in G(z).
Gz=vpa(simplify(Gz),6);  %Simplify G(z) and evaluate numerical
                          %values to 6 places.

Gz=vpa(factor(Gz),6);    %Factor G(z).
'G(z) evaluated for T=0.5' %Display label.
pretty(Gz)               %Pretty print G(z) with numerical
                          %values.
```

**Computer response:**

ans =

(a)

ans =

G(s)

$$\frac{s + 4}{(s + 2)(s + 5)}$$

ans =

G(z) evaluated for T=0.5

$$1.00000 \frac{z(z - .177350)}{(z - .0820850)(z - .367880)}$$

ans =

(b)

ans =

G(s)

$$\frac{(s + 1)(s + 2)}{s(s + 3)(s + 4)}$$

ans =

G(z) evaluated for T=0.5

$$1.00000 \frac{z(z - .296742)(z - .840812)}{(z - .135335)(z - .223130)(z - 1.)}$$

ans =

ans =

(c)

ans =

G(s)

$$\frac{20}{(s + 3)(s^2 + 6s + 25)}$$

ans =

G(z) evaluated for T=0.5

$$.394980 \frac{(z + .223130) z}{(z - .223135) (z^2 + .185705 z + .0497861)}$$

ans =

(d)

ans =

G(s)

$$\frac{15}{s (s + 1) (s^2 + 10 s + 81)}$$

ans =

G(z) evaluated for T=0.5

$$.0578297 \frac{(z + .289175) (z + .116364) z}{(z - .606535) (z - .999995) (z^2 + .135489 z + .00673794)}$$

8.

a.

$$G_2(s) = G(s)/s = \frac{20}{s^2 (s + 5)} = \frac{4}{s^2} - \frac{4}{5} \frac{1}{s} + \frac{4}{5} \frac{1}{s + 5}$$

Thus,

$$g_2(t) = 4 k T - \frac{4}{5} + \frac{4}{5} \exp(-5 k T)$$

Hence,

$$G(z) = (1 - 1/z) \left[ \frac{4}{(z - 1)^2} - \frac{4/5}{z - 1} + \frac{4/5}{\exp(-5 T) \left( \frac{z}{\exp(-5 T)} - 1 \right)} \right]$$

Letting T=0.3,

$$G(z) = 4000 \frac{6.482 z + 3.964}{(z - 1.) (4.482 z - 1.)}$$

b.

$$G_2(s) = G(s)/s = \frac{20}{s^2(s+5)(s+3)} = \frac{4/3}{s} - \frac{32}{45(s+3)} + \frac{10/9}{s+5}$$

Thus,

$$g_2t = \frac{4}{3} k T - \frac{32}{45} + \frac{10}{9} \exp(-3 k T) - \frac{2}{5} \exp(-5 k T)$$

Hence,

$$G(z) = (1 - 1/z) \left[ \frac{4/3}{(z-1)^2} - \frac{32}{45(z-1)} + \frac{10/9}{\exp(-3T) \left( \frac{z}{\exp(-3T)} - 1 \right)} - \frac{2/5}{\exp(-5T) \left( \frac{z}{\exp(-5T)} - 1 \right)} \right]$$

Letting  $T = 0.3$ ,

$$G(z) = .04444 \frac{12.82 z^2 + 29.1 z + 3.84}{(z - 1.) (2.460 z - 1.) (4.482 z - 1.)}$$

c.

$$G_e(z) = G_a(z)G(z)$$

where  $G_a(z)$  is the answer to part (a) and  $G(z)$ , the pulse transfer function for  $\frac{1}{s+3}$  in cascade with a zero-order-hold will now be found:

$$G_2(s) = G(s)/s = \frac{1}{s(s+3)} = \frac{1}{s} - \frac{1/3}{s+3}$$

Thus,

$$g_2t = 1/3 - 1/3 \exp(-3 k T)$$

Hence,



$$G(z) = (1 - 1/z) \left| \frac{1/3}{z-1} - \frac{1/3}{z} \right| \frac{z}{\exp(-3T) - 1} \Big|_{z=1}$$

Letting  $T = 0.3$ ,

$$G(z) = \frac{.4866}{2.460z - 1}$$

Thus,

$$G_e(z) = G_a(z)G(z) = 0.19464 \frac{6.482z + 3.964}{(z-1)(4.482z-1)(2.46z-1)}$$

9.

- a. Add phantom samplers at the input, output, and feedback path after  $H(s)$ . Push  $G_2(s)$  and its input sampler to the right past the pickoff point. Add a phantom sampler after  $G_1(s)$ . Hence,

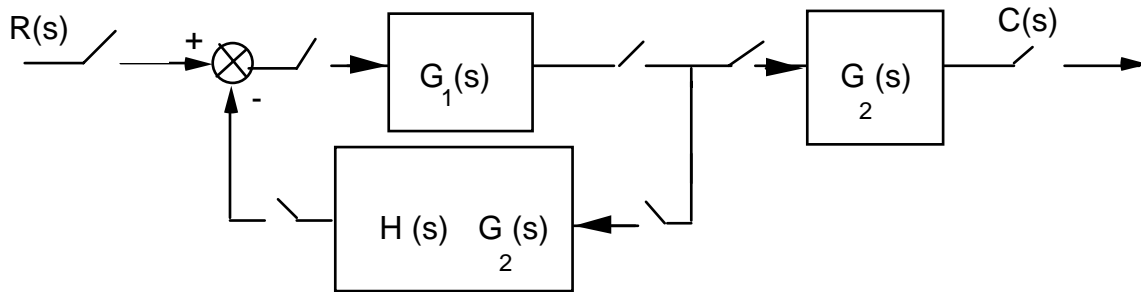

From this block diagram,  $T(z) = \frac{G_1(z)G_2(z)}{1 + G_1(z)HG_2(z)}$ .

- b. Add phantom samplers to the input, output, and the output of  $H(s)$ . Push  $G_1(s)G_2(s)$  and its input sampler to the right past the pickoff point. Add a phantom sampler at the output.

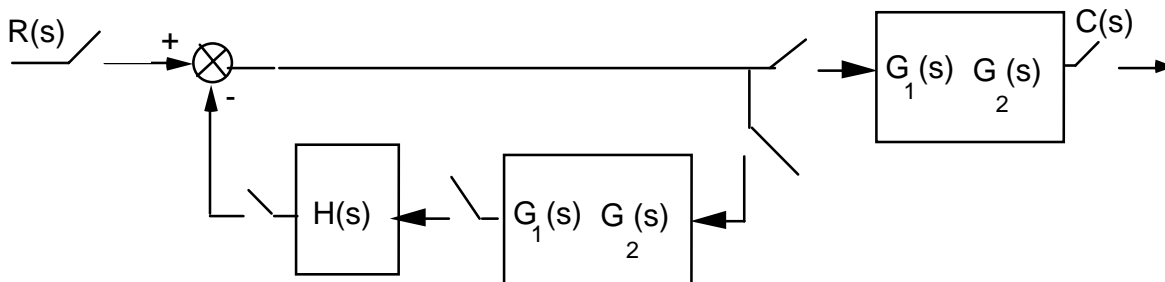

From this block diagram,  $T(z) = \frac{G_1 G_2(z)}{1 + G_1 G_2(z) H(z)}$ .

10.

Add phantom samplers after  $G_1(s)$ ,  $G_3(s)$ ,  $G_4(s)$ ,  $H_1(s)$ , and  $H_2(s)$ .

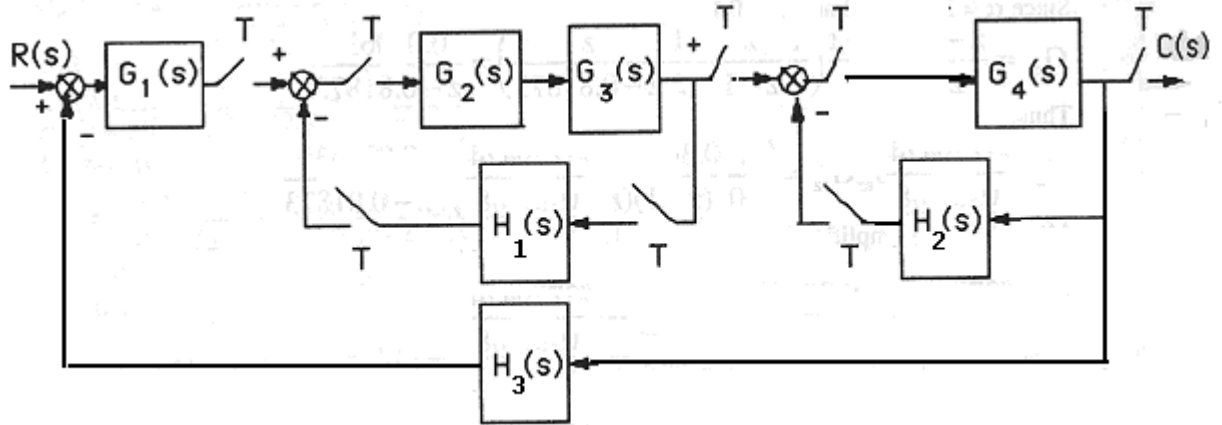

Push  $G_1(s)$  and its sampler to the left past the summing junction. Also, push  $G_4(s)$  and its input sampler to the right past the pickoff point. The resulting block diagram is,

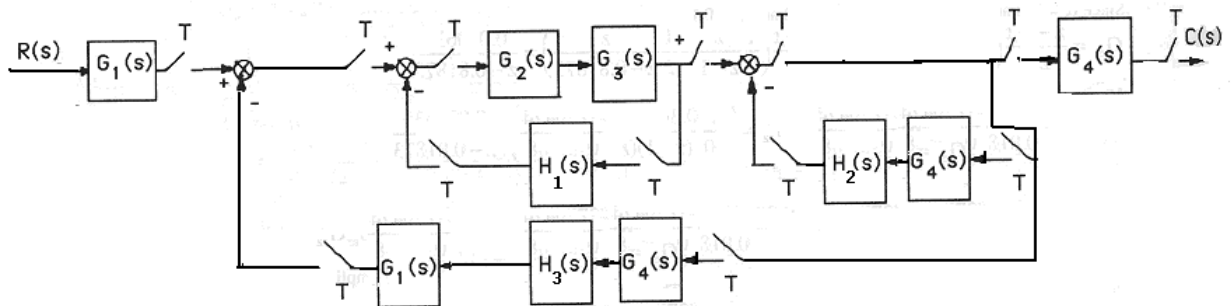

Converting to z transforms,

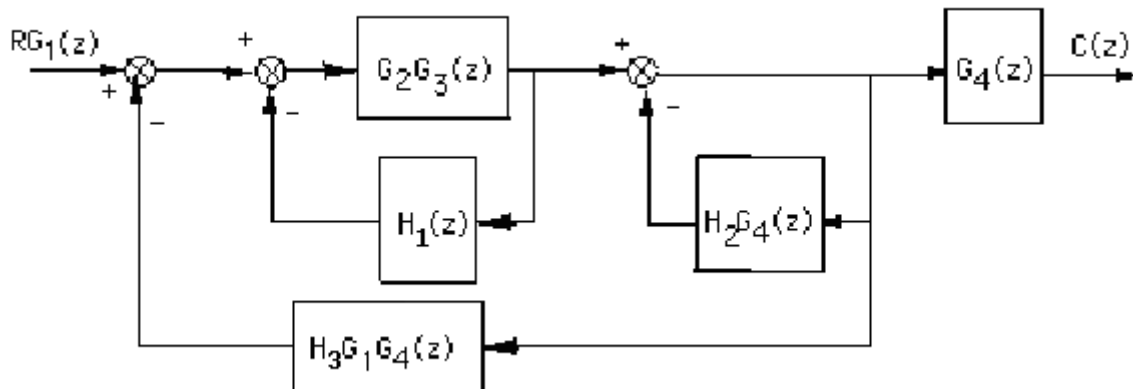

$$C(s) = RG_1(z)G_4(z) \left[ \frac{\frac{G_2G_3(z)}{(1+G_2G_3(z)H_1(z))} * \frac{1}{(1+H_2G_4(z))}}{1 + \frac{G_2G_3(z)}{(1+G_2G_3(z)H_1(z))} * \frac{1}{(1+H_2G_4(z))} H_3G_1G_4(z)} \right]$$

$$= \frac{RG_1(z)G_4(z)G_2G_3(z)}{(1+G_2G_3(z)H_1(z))(1+H_2G_4(z)) + G_2G_3(z)H_3G_1G_4(z)}$$

11.

Push gain of 2 to the left past the summing junction and add phantom samplers as shown.

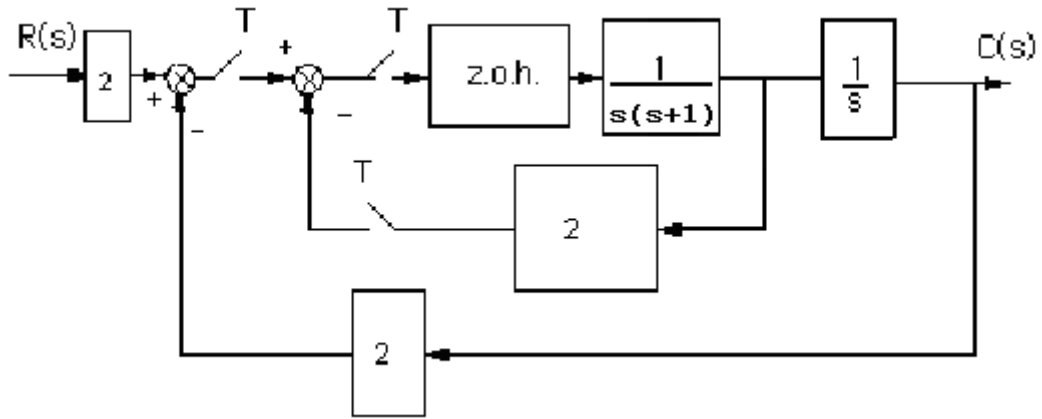

Push the z.o.h. and  $\frac{1}{s(s+1)}$  to the right past the pickoff point. Also, add a phantom sampler at the output.

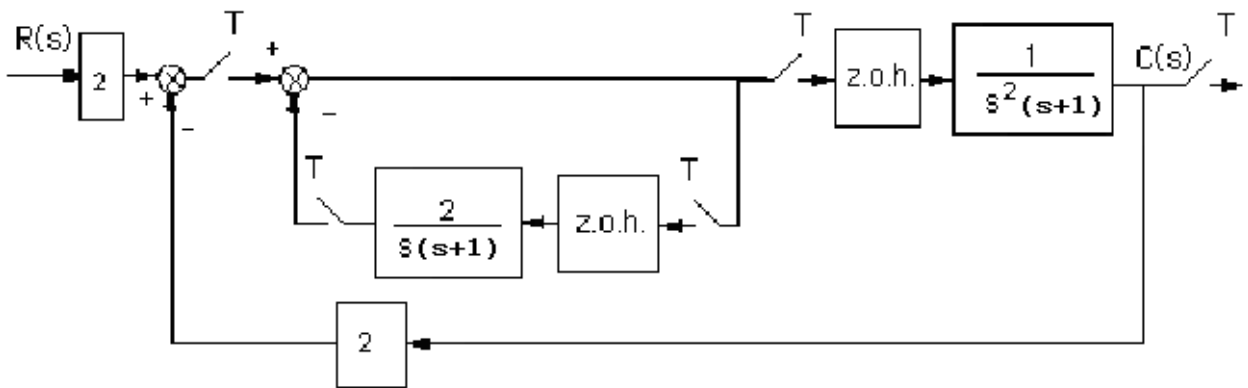

Add phantom samplers after the gain of 2 at the input and in the feedback. Also, represent the z.o.h. as Laplace transforms.

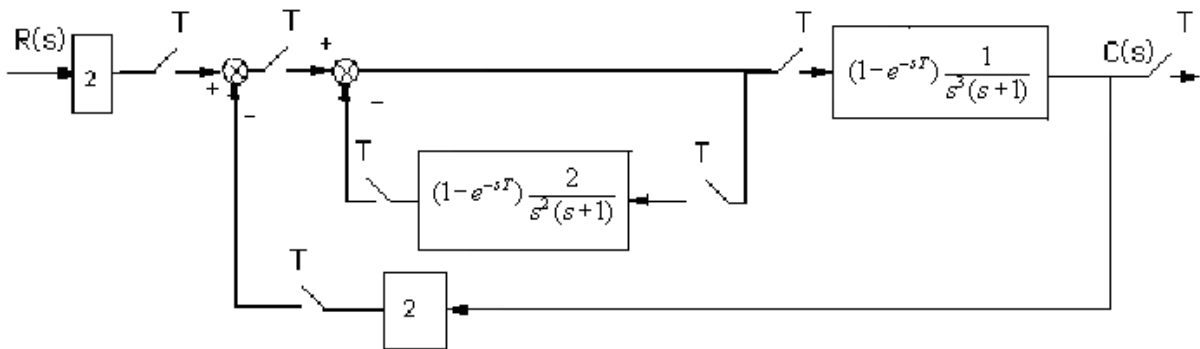

Push the last block to the right past the pickoff point and get,

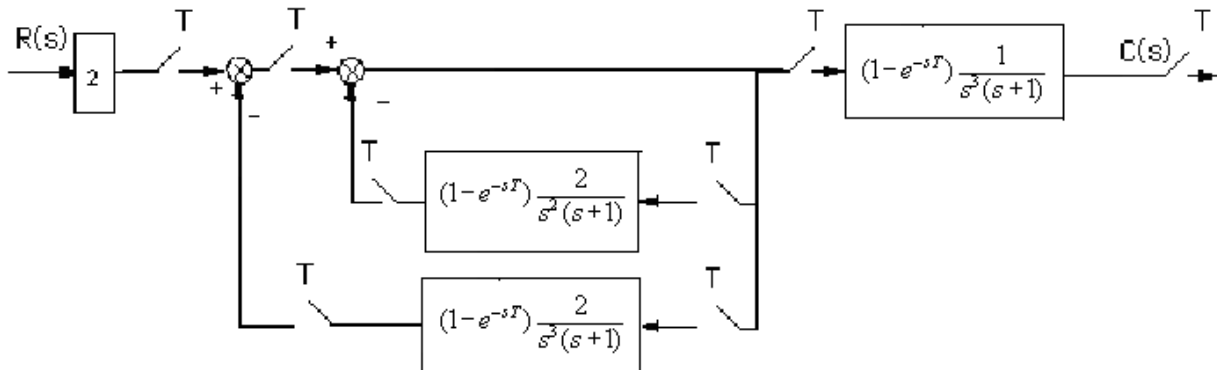

Find the z transform for each transfer function.

$$G_1(s) = 2$$

transforms into

$$G_1(z) = 2.$$

$$H_1(s) = (1 - e^{-sT}) \frac{2}{s^2(s+1)} = (1 - e^{-sT}) \left[ \frac{2}{s^2} - \frac{2}{s} + \frac{2}{s+1} \right]$$

transforms into

$$H_1(z) = \frac{z-1}{z} \left[ 2 \frac{Tz}{(z-1)^2} - 2 \frac{z}{z-1} + 2 \frac{z}{z-e^{-T}} \right] = 2 \frac{Tz - Te^{-T} + ze^{-T} - z - e^{-T} + 1}{(z-1)(z-e^{-T})}$$

$$H_2(s) = (1 - e^{-sT}) \frac{2}{s^3(s+1)} = (1 - e^{-sT}) \left[ \frac{2}{s} - \frac{2}{s+1} - \frac{2}{s^2} + \frac{2}{s^3} \right]$$

transforms into

$$H_2(z) = \frac{z-1}{z} \left[ \frac{2z}{z-1} - \frac{2z}{z-e^{-T}} - \frac{2Tz}{(z-1)^2} + \frac{T^2 z(z+1)}{(z-1)^3} \right]$$

$$= \frac{(T^2 - 2e^{-T} + 2 - 2T)z^2 + (4e^{-T} - 4 + 2Te^{-T} + 2T + T^2 - T^2e^{-T})z + (2 - 2e^{-T} - 2Te^{-T} - T^2e^{-T})}{(z-1)^2(z-e^{-T})}$$

$$G_2(s) = (1 - e^{-sT}) \frac{1}{s^3(s+1)}$$

transforms into

$$\frac{1}{2} H_2(z)$$

Thus, the closed-loop transfer function is

$$T(z) = G_1(z)G_2(z) \left[ \frac{1}{1 + H_1(z) + H_2(z)} \right]$$

12.

$$G(z) = \frac{z-1}{z} z \left\{ \frac{1}{s^2(s+1)} \right\}.$$

Using Eq. (13.49)

$$G(z) = \frac{T}{z-1} - \frac{(1-e^{-T})}{z-e^{-T}} = \frac{(T-1+e^{-T})z + (1-e^{-T}-Te^{-T})}{(z-1)(z-e^{-T})}$$

But,

$$T(z) = \frac{G(z)}{1+G(z)} = \frac{(T-1+e^{-T})z + (1-e^{-T}-Te^{-T})}{z^2 + (T-2)z + (1-Te^{-T})}$$

The roots of the denominator are inside the unit circle for  $0 < T < 3.923$ .

13.

**Program:**

```
numg1=10*[1 7];
deng1=poly([-1 -3 -4 -5]);
G1=tf(numg1,deng1);
for T=5:-.01:0;
Gz=c2d(G1,T,'zoh');
Tz=feedback(Gz,1);
r=pole(Tz);
rm=max(abs(r));
if rm<=1;
break;
end;
end;
T
r
rm
```

**Computer response:**

T =

3.3600

r =

-0.9990  
-0.0461  
-0.0001

```

-0.0000

rm =
    0.9990

>>
T =
    3.3600

r =
   -0.9990
   -0.0461
   -0.0001
   -0.0000

rm =
    0.9990

```

**14.**

$$G(s) = K(1 - e^{-sT}) \frac{3}{s^2(s+4)}$$

$$G(s) = K(1 - e^{-sT}) \left[ \frac{0.1875}{s+4} - \frac{0.1875}{s} + \frac{0.75}{s^2} \right]$$

$$G(z) = K \left[ \frac{z-1}{z} \left\{ 0.1875 \frac{z}{z - e^{-4(0.2)}} - 0.1875 \frac{z}{z-1} + 0.75 \frac{0.2z}{(z-1)^2} \right\} \right]$$

$$G(z) = K \frac{0.0467(z+0.767)}{(z-0.4493)(z-1)}$$

$$K = 0.736/0.0467 = 15.76$$

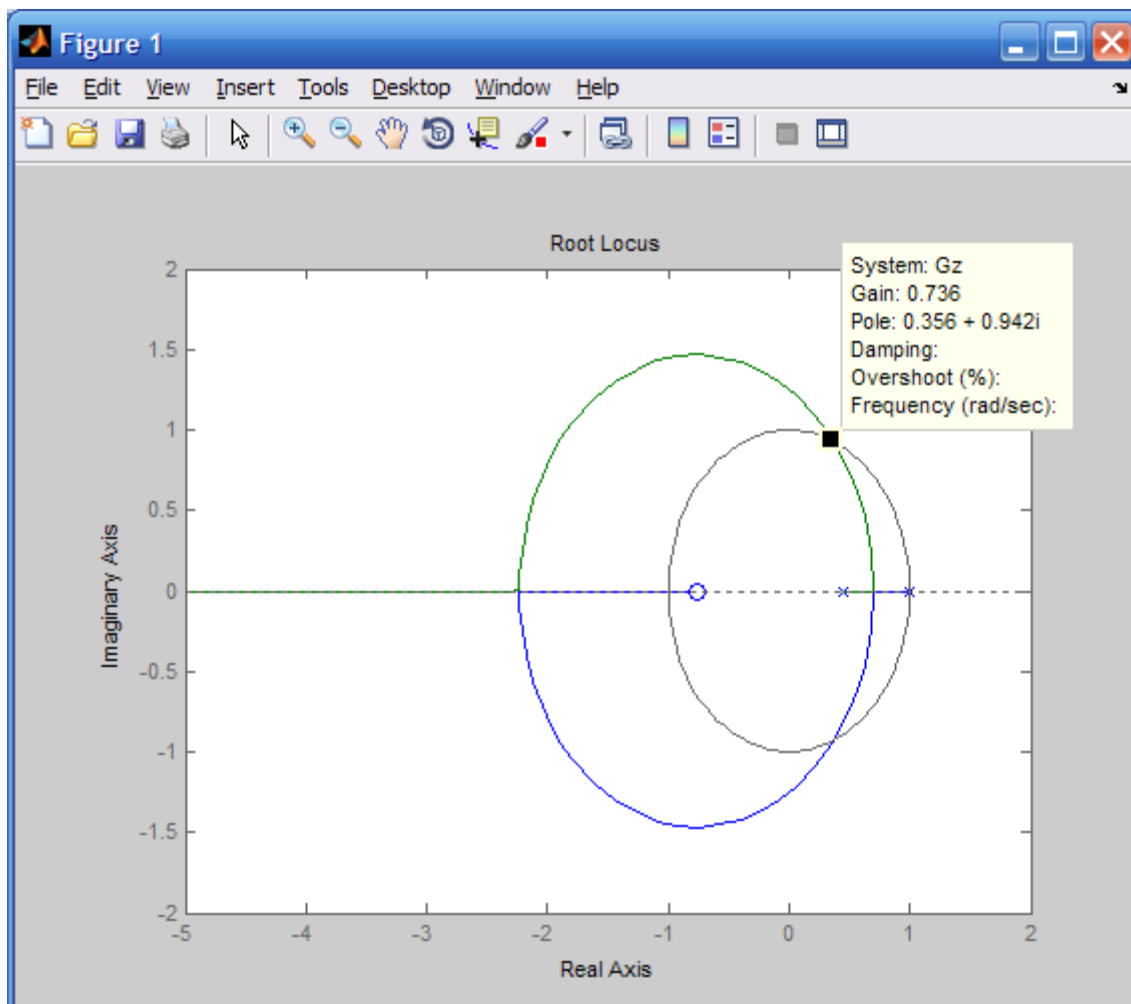

15.  
a.

$$G_s = (1 - e^{-Ts}) \frac{1}{s(s + \alpha)}$$

$$G_s = (1 - e^{-Ts}) \left( -\frac{1}{\alpha[s + \alpha]} + \frac{1}{\alpha s} \right)$$

$$G_z = \frac{z-1}{z} \left( -\frac{1}{\alpha} \frac{z}{z - e^{-\alpha T}} + \frac{1}{\alpha} \frac{z}{z-1} \right)$$

$$G_z = \frac{-\frac{1}{e^{T\alpha}} + 1}{\alpha \left( z - \frac{1}{e^{T\alpha}} \right)}$$

$$\alpha = 2$$

$$T = 0.5$$

$$G_z = 0.31606 \frac{1}{z - 0.36788}$$

First, check to see that the system is stable.

$$T_z = \frac{G_z}{1+G_z}$$

$$T_z = 0.31606 \frac{1}{z-0.051819}$$

Since the closed-loop poles are inside the unit circle, the system is stable. Next, evaluate the static error constants and the steady-state error.

$$K_p = \lim_{z \rightarrow 1} G(z) = 0.5 \quad e^*(\infty) = \frac{1}{1+K_p} = \frac{2}{3}$$

$$K_v = \frac{1}{T} \lim_{z \rightarrow 1} (z-1)G(z) = 0 \quad e^*(\infty) = \frac{1}{K_v} = \infty$$

$$K_a = \frac{1}{T^2} \lim_{z \rightarrow 1} (z-1)^2 G(z) = 0 \quad e^*(\infty) = \frac{1}{K_a} = \infty$$

b.

$$G_s = (1 - e^{-Ts}) \frac{K\alpha}{s^2(s+\alpha)}$$

From Equation 13.48

$$G_z = K \frac{\alpha T(z - e^{-\alpha T}) - (z-1)(1 - e^{-\alpha T})}{\alpha(z-1)(z - e^{-\alpha T})}$$

$$K = 10$$

$$\alpha = 2$$

$$T = 0.1$$

$$G_z = 5 \frac{0.018731(z + 0.93553)}{(z-1)(z - 0.81873)}$$

First, test stability.

$$T_z = \frac{G_z}{1+G_z}$$

$$T_z = 0.093654 \frac{z + 0.93553}{(z - 0.86254 + 0.40296i)(z - 0.86254 - 0.40296i)}$$

The system is stable. The closed-loop poles are inside the unit circle. Now find the static error constants and the steady-state errors.

$$K_p = \lim_{z \rightarrow 1} G(z) = \infty \quad e^*(\infty) = \frac{1}{1+K_p} = 0$$

$$K_v = \frac{1}{T} \lim_{z \rightarrow 1} (z-1)G(z) = 10 \quad e^*(\infty) = \frac{1}{K_v} = 0.1$$

$$K_a = \frac{1}{T^2} \lim_{z \rightarrow 1} (z-1)^2 G(z) = 0 \quad e^*(\infty) = \frac{1}{K_a} = \infty$$



c.

$$G_z = \frac{1.28}{z - 0.37}$$

First, test stability.

$$T_z = \frac{G_z}{1 + G_z}$$

$$T_z = 1.28 \frac{1}{z + 0.91}$$

The system is stable. The closed-loop pole is inside the unit circle. Now find the static error constants and the steady-state errors.

$$K_p = \lim_{z \rightarrow 1} G(z) = 2.03 \quad e^*(\infty) = \frac{1}{1 + K_p} = 0.33$$

$$K_v = \frac{1}{T} \lim_{z \rightarrow 1} (z - 1)G(z) = 0 \quad e^*(\infty) = \frac{1}{K_v} = \infty$$

$$K_a = \frac{1}{T^2} \lim_{z \rightarrow 1} (z - 1)^2 G(z) = 0 \quad e^*(\infty) = \frac{1}{K_a} = \infty$$

d.

$$G_z = \frac{0.13(z + 1)}{(z - 1)(z - 0.74)}$$

First, test stability.

$$T_z = \frac{G_z}{1 + G_z}$$

$$T_z = 0.13 \frac{z + 1}{z^2 - 1.61z + 0.87}$$

$$T_z = 0.13 \frac{z + 1}{(z + [-0.805 + 0.47114i])(z + [-0.805 - 0.47114i])}$$

The system is stable. The closed-loop pole is inside the unit circle. Now find the static error constants and the steady-state errors.

$$K_p = \lim_{z \rightarrow 1} G(z) = \infty \quad e^*(\infty) = \frac{1}{1 + K_p} = 0$$

$$K_v = \frac{1}{T} \lim_{z \rightarrow 1} (z - 1)G(z) = 10 \quad e^*(\infty) = \frac{1}{K_v} = 0.1$$

$$K_a = \frac{1}{T^2} \lim_{z \rightarrow 1} (z - 1)^2 G(z) = 0 \quad e^*(\infty) = \frac{1}{K_a} = \infty$$

16.

**Program:**

```

T=0.1;
numgz=[0.04406 -0.03624 -0.03284 0.02857];
dengz=[1 -3.394 +4.29 -2.393 +0.4966];
'G(z)'
Gz=tf(numgz,dengz,0.1)
'Zeros of G(z)'
zeros=roots(numgz)
'Poles of G(z)'
poles=roots(dengz)
%Check stability
Tz=feedback(Gz,1);
'Closed-Loop Poles'
r=pole(Tz)
M=abs(r)
pause
'Find Kp'
Gz=minreal(Gz,.00001);
Kp=dcgain(Gz)
'Find Kv'
factorkv=tf([1 -1],[1 0],0.1); %Makes transfer function
                                %proper and yields same Kv
Gzkv=factorkv*Gz;

Gzkv=minreal(Gzkv,.00001); %Cancel common poles and
                                %zeros
Kv=(1/T)*dcgain(Gzkv)
'Find Ka'
factorka=tf([1 -2 1],[1 0 0],0.1);%Makes transfer function
                                %proper and yields same Ka
Gzka=factorka*Gz;

Gzka=minreal(Gzka,.00001); %Cancel common poles and
                                %zeros
Ka=(1/T)^2*dcgain(Gzka)

```

**Computer response:**

```

ans =

G(z)

Transfer function:
0.04406 z^3 - 0.03624 z^2 - 0.03284 z + 0.02857
-----
z^4 - 3.394 z^3 + 4.29 z^2 - 2.393 z + 0.4966

Sampling time: 0.1

ans =

Zeros of G(z)

zeros =

    -0.8753
    0.8489 + 0.1419i
    0.8489 - 0.1419i

ans =

Poles of G(z)

poles =

```

```

1.0392
0.8496 + 0.0839i
0.8496 - 0.0839i
0.6557

```

```
ans =
```

```
Closed-Loop Poles
```

```
r =
```

```

0.9176 + 0.1699i
0.9176 - 0.1699i
0.7573 + 0.1716i
0.7573 - 0.1716i

```

```
M =
```

```

0.9332
0.9332
0.7765
0.7765

```

```
ans =
```

```
Find Kp
```

```
Kp =
```

```
-8.8750
```

```
ans =
```

```
Find Kv
```

```
Kv =
```

```
0
```

```
ans =
```

```
Find Ka
```

```
Ka =
```

```
0
```

- 17.** First find  $G(z)$

$$G(s) = K(1 - e^{-sT}) \frac{1}{s(s+1)(s+4)}$$

$$G(s) = K(1 - e^{-sT}) \left[ \frac{1/4}{s} - \frac{1/3}{s+1} + \frac{0.0833}{s+4} \right]$$

$$G(z) = K \left[ \frac{z-1}{z} \left\{ \frac{1}{4} \frac{z}{z-1} - \frac{1}{3} \frac{z}{z-e^{-(0.1)}} - +0.0833 \frac{z}{z-e^{-4(0.1)}} \right\} \right]$$

$$G(z) = K \frac{0.00431(z+0.8283)}{(z-0.90484)(z-0.6703)}$$

Next, plot the root locus.

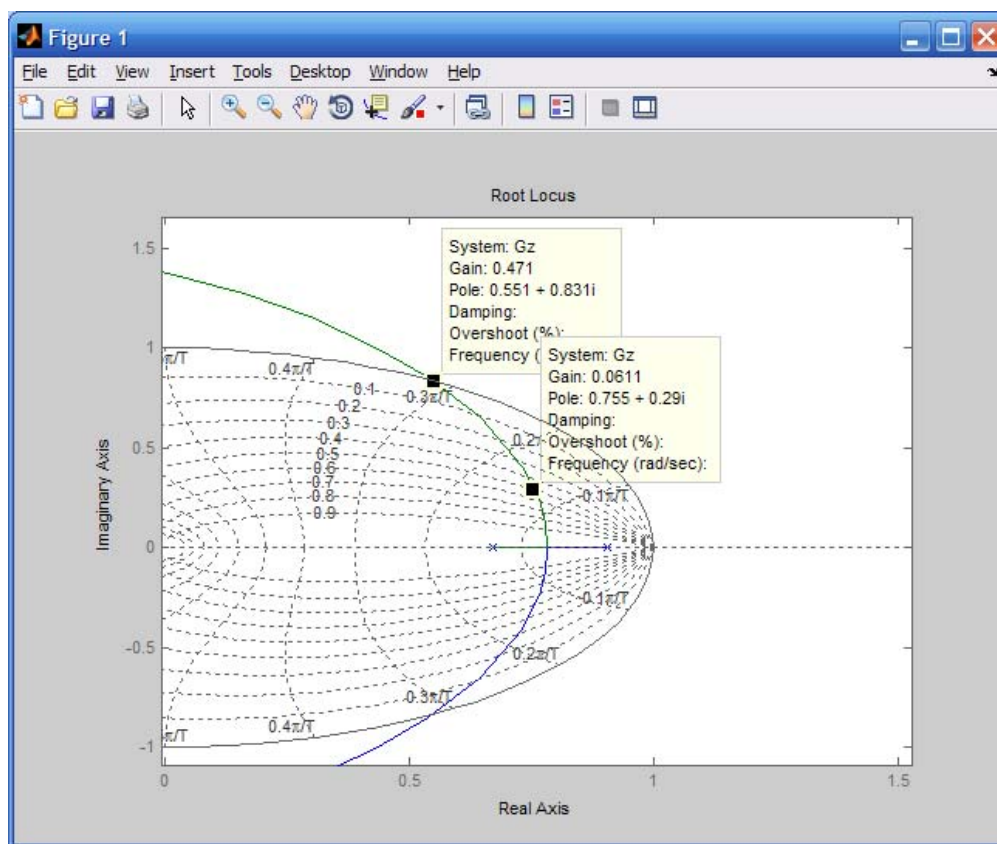

Root locus intersects 0.5 damping ratio for  $0.00431K = 0.0611$ . Thus,  $K = 14.18$  for 16.3% overshoot. Root locus intersects the unit circle for  $0.00431K = 0.47$ . Thus  $0 < K < 109.28$  for stability.

18.

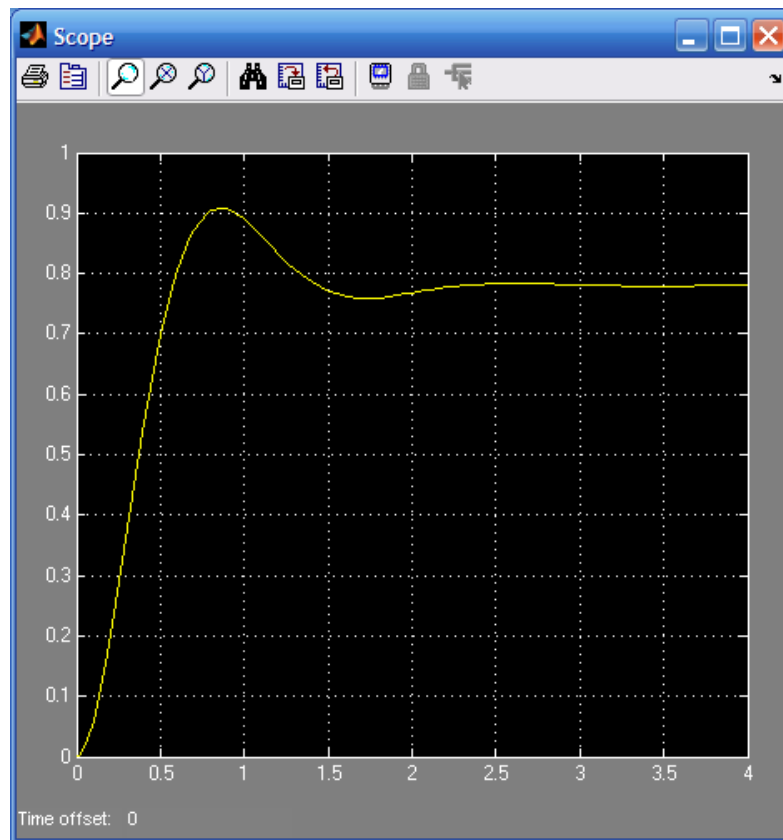
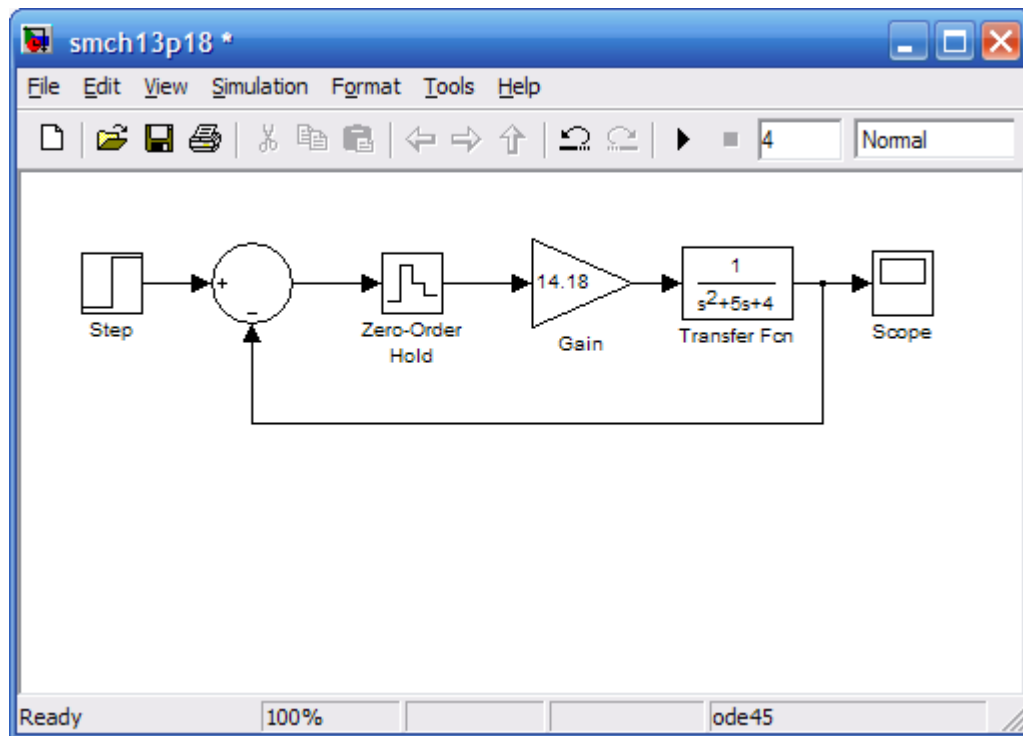

19.

**Program:**

```

numgz=0.13*[1 1];
dengz=poly([1 0.74]);
Gz=tf(numgz,dengz,0.1)
Gzpkz=zpk(Gz)
Tz=feedback(Gz,1)
Ltiview

```

**Computer response:**

```

Transfer function:
    0.13 z + 0.13
-----
z^2 - 1.74 z + 0.74

Sampling time: 0.1

```

```

Zero/pole/gain:
    0.13 (z+1)
-----
(z-1) (z-0.74)

```

```

Sampling time: 0.1

```

```

Transfer function:
    0.13 z + 0.13
-----
z^2 - 1.61 z + 0.87

Sampling time: 0.1

```

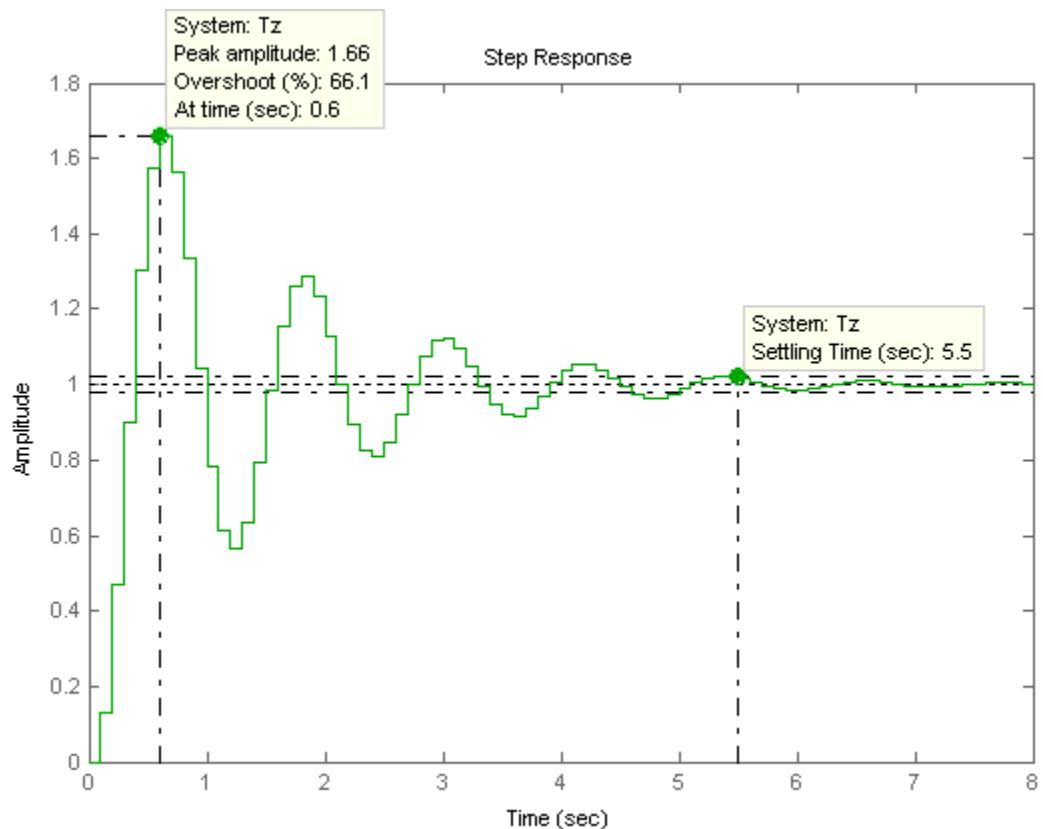

20.

**Program:**

```

%Digitize G1(s) preceded by a sample and hold
numg1=1;
deng1=poly([-1 -3]);
'G1(s)'
G1s=tf(numg1,deng1)
'G(z)'
Gz=c2d(G1s,0.1,'zoh')
%Input transient response specifications
Po=input('Type %OS ');
%Determine damping ratio
z=(-log(Po/100))/(sqrt(pi^2+log(Po/100)^2));
%Plot root locus
rlocus(Gz)
zgrid(z,0)
title(['Root Locus'])
[K,p]=rlocfind(Gz) %Allows input by selecting point on graphic
pause
'T(z)'
Tz=feedback(K*Gz,1)
step(Tz)

```

**Computer response:**

ans =

G1(s)

Transfer function:

$$\frac{1}{s^2 + 4s + 3}$$

ans =

G(z)

Transfer function:

$$\frac{0.004384z + 0.003837}{z^2 - 1.646z + 0.6703}$$

Sampling time: 0.1

Type %OS 16.3

Select a point in the graphics window

selected\_point =

0.8016 + 0.2553i

K =

9.7200

p =

$$\begin{aligned} &0.8015 + 0.2553i \\ &0.8015 - 0.2553i \end{aligned}$$

ans =

$T(z)$

Transfer function:

$$\frac{0.04262 z + 0.0373}{z^2 - 1.603 z + 0.7076}$$

---

$$z^2 - 1.603 z + 0.7076$$

Sampling time: 0.1

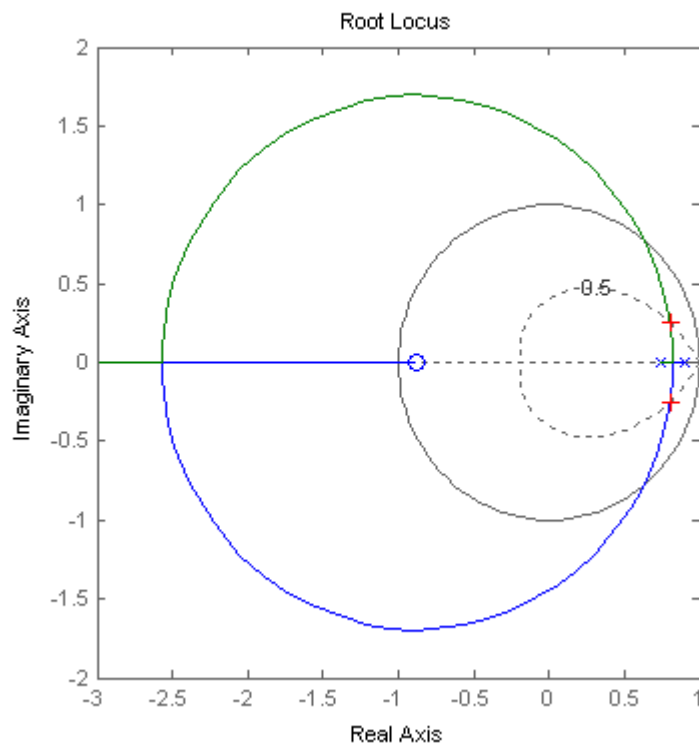



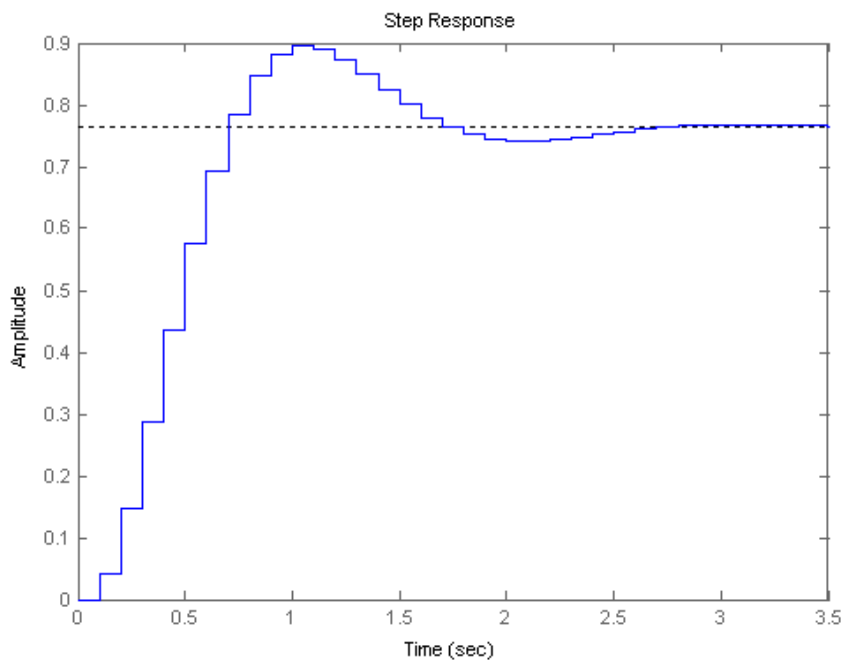

21.

Using the result from Problem 13.12

$$G_z = \frac{(T - 1 + e^{-T})z + (1 - e^{-T} - Te^{-T})}{(z-1)(z-e^{-T})} K$$

Letting  $T=0.1$ ,

$$G_z = \frac{(0.0048374(z + 0.96722)) K}{(z-1)(z-0.90484)}$$

For  $T_p = 2$  seconds,

$$\frac{T_p}{T} = 20$$

Hence,

$$\frac{\pi}{\theta_1} = 20$$

Or,

$$\theta_1 = 9^\circ$$

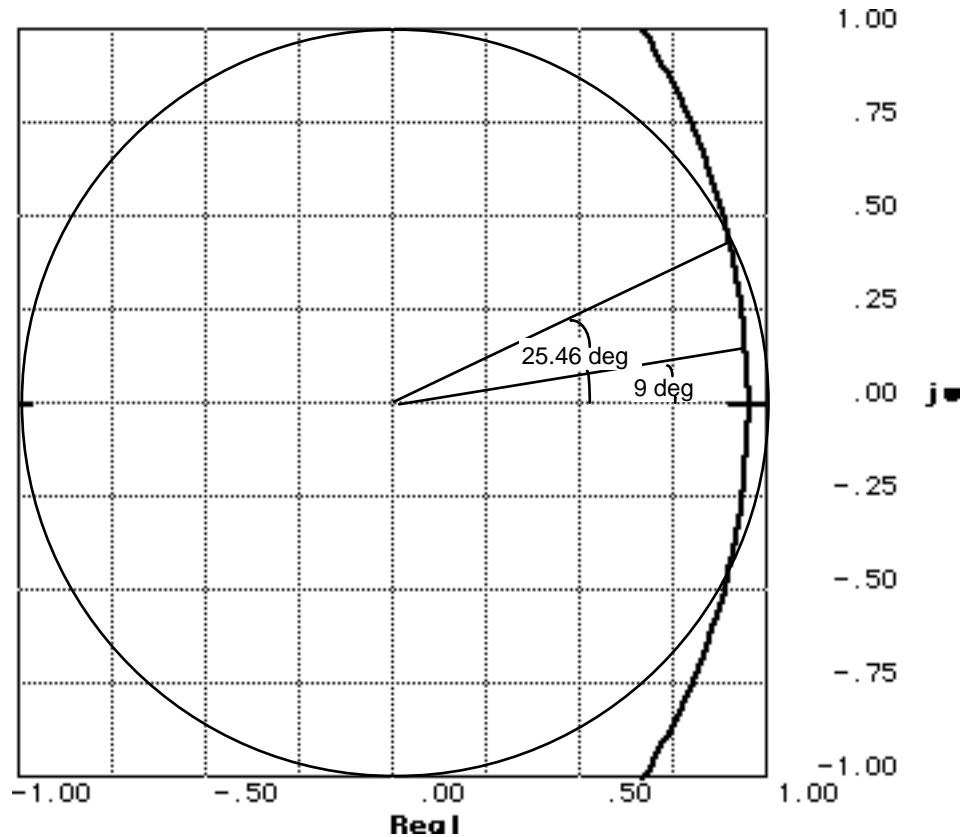

The root locus intersects the  $T_p/T$  curve at  $0.958 < 9$  deg. with a gain of 0.0129. Hence,  $4.837E-3 K = 0.0129$ , or  $K=2.67$ .

To determine stability, we see that the root locus intersects the 0 damping ratio curve at  $1 < 25.4$  deg. with a gain of 0.0983. Hence,  $4.837E-3 K = 0.0983$ , or  $K=20.32$ .

22.

$$\text{First find } G(z). G(z) = K \frac{z-1}{z} z \left\{ \frac{1}{s^2(s+1)(s+3)} \right\} = K \frac{z-1}{z}$$

$$z \left\{ -\frac{1}{18} \frac{1}{s+3} + \frac{1}{2} \frac{1}{s+1} - \frac{4}{9} \frac{1}{s} + \frac{1}{3} \frac{1}{s^2} \right\}$$

$$\text{For } T=0.1, G(z) = K \frac{z-1}{z} \left( \frac{-\frac{1}{18} z}{z-0.74082} + \frac{\frac{1}{2} z}{z-0.90484} - \frac{\frac{4}{9} z}{z-1} + \frac{\frac{1}{30} z}{[z-1]^2} \right)$$

$$= 0.00015103K \frac{(z+0.24204)(z+3.3828)}{(z-1)(z-0.74082)(z-0.90484)}. \text{ Plotting the root locus and overlaying}$$

the 20% overshoot curve, we select the point of intersection and calculate the gain:  $0.00015103K = 1.789$ . Thus,  $K = 11845.33$ . Finding the intersection with the unit circle yields  $0.00015103K = 9.85$ .

Thus,  $0 < K < 65218.83$  for stability.

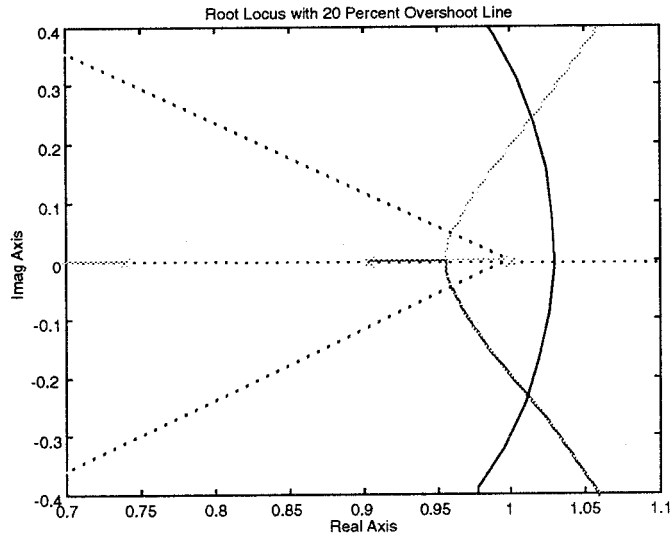

23.

First find  $G(z)$ .  $G(z) = K \frac{z-1}{z} z \left\{ \frac{(s+2)}{s^2(s+1)(s+3)} \right\} = K \frac{z-1}{z} z \left\{ \frac{1}{18} \frac{1}{s+3} + \frac{1}{2} \frac{1}{s+1} - \frac{5}{9} \frac{1}{s} + \frac{2}{3} \frac{1}{s^2} \right\} =$

For  $T=1$ ,  $G(z) = K \frac{z-1}{z} \left( \frac{\frac{1}{18} z}{z-0.049787} + \frac{\frac{1}{2} z}{z-0.36788} - \frac{\frac{5}{9} z}{z-1} + \frac{\frac{2}{3} z}{[z-1]^2} \right)$

$= 0.29782K \frac{(z-0.13774)(z+0.55935)}{(z-1)(z-0.049787)(z-0.36788)}$ . Plotting the root locus and overlaying the  $T_s = 15$

second circle, we select the point of intersection  $(0.4 + j0.63)$  and calculate the gain:  $0.29782K = 1.6881$ . Thus,  $K = 5.668$ . Finding the intersection with the unit circle yields  $0.29782K = 4.4$ . Thus,  $0 < K < 14.77$  for stability.

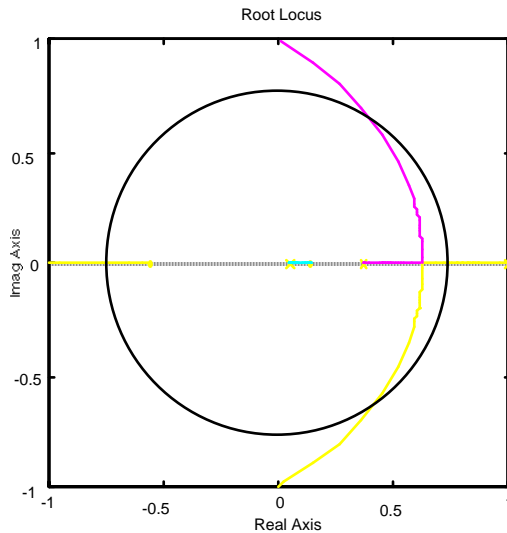

24.

Substituting Eq. (13.88) into  $G_c(s)$  and letting  $T = 0.01$  yields

$$G_c(z) = \frac{1180z^2 - 1839z + 661.1}{z^2 - 1} = 1180 \frac{(z - 0.9959)(z - 0.5625)}{(z + 1)(z - 1)}$$

25.

$$\text{Since \%OS} = 10\%, \zeta = \frac{-\ln\left(\frac{\%OS}{100}\right)}{\sqrt{\pi^2 + \ln^2\left(\frac{\%OS}{100}\right)}} = 0.591. \text{ Since } T_s = \frac{4}{\zeta\omega_n} = 2 \text{ seconds,}$$

$\omega_n = 3.383$  rad/s. Hence, the location of the closed-loop poles must be  $-2 \pm j2.729$ . The summation of angles from open-loop poles to  $-2 \pm j2.729$  is  $-192.99^\circ$ . Therefore, the design point is not on the root locus. A compensator whose angular contribution is  $192.99^\circ - 180^\circ = 12.99^\circ$  is required. Assume a compensator zero at  $-5$  canceling the pole at  $-5$ . Adding the compensator zero at  $-5$  to the plant's poles yields  $-150.69^\circ$  at to  $-2 \pm j2.729$ . Thus, the compensator's pole must contribute  $180^\circ - 150.69^\circ = 29.31^\circ$ . The following geometry results.

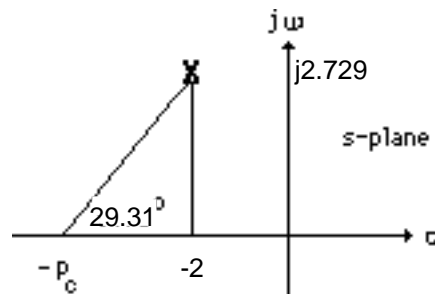

Thus,

$$\frac{2.729}{p_c - 2} = \tan(29.31^\circ)$$

Hence,  $p_c = 6.86$ . Adding the compensator pole and zero to the system poles, the gain at the design point is found to be 124.3. Summarizing the results:  $G_c(s) = \frac{124.3(s + 5)}{(s + 6.86)}$ . Substituting

Eq. (13.88) into  $G_c(s)$  and letting  $T = 0.01$  yields

$$G_c(z) = \frac{123.2z - 117.2}{z - 0.9337} = \frac{123.2(z - 0.9512)}{(z - 0.9337)}$$

26.

**Program:**

```
'Design of digital lead compensation'
clf                                %Clear graph on screen.
'Uncompensated System'           %Display label.
numg=1;                            %Generate numerator of G(s).
deng=poly([0 -5 -8]);             %Generate denominator of G(s).
'G(s)'                             %Display label.
G=tf(numg,deng)                   %Create and display G(s).
pos=input('Type desired percent overshoot ');
                                %Input desired percent overshoot.
z=-log(pos/100)/sqrt(pi^2+[log(pos/100)]^2);
                                %Calculate damping ratio.
rlocus(G)                          %Plot uncompensated root locus.
sgrid(z,0)                         %Overlay desired percent overshoot
                                %line.
title(['Uncompensated Root Locus with ', num2str(pos), ...
```

```

'% Overshoot Line'])                                %Title uncompensated root locus.
[K,p]=rlocfind(G);                                  %Generate gain, K, and closed-loop
                                                    %poles, p, for point selected
                                                    %interactively on the root locus.

'Closed-loop poles = '                              %Display label.
p                                                    %Display closed-loop poles.
f=input('Give pole number that is operating point '); %Choose uncompensated system
                                                    %dominant pole.

'Summary of estimated specifications for selected point on'
'uncompensated root locus'                          %Display label.
operatingpoint=p(f)                                %Display uncompensated dominant
                                                    %pole.
gain=K                                              %Display uncompensated gain.
estimated_settling_time=4/abs(real(p(f)))           %Display uncompensated settling
                                                    %time.
estimated_peak_time=pi/abs(imag(p(f)))             %Display uncompensated peak time.
estimated_percent_overshoot=pos                    %Display uncompensated percent
                                                    %overshoot.
estimated_damping_ratio=z                          %Display uncompensated damping
                                                    %ratio.
estimated_natural_frequency=sqrt(real(p(f))^2+imag(p(f))^2) %Display uncompensated natural
                                                    %frequency.
numkv=conv([1 0],numg);                            %Set up numerator to evaluate Kv.
denkv=deng;                                         %Set up denominator to evaluate Kv.
sG=tf(numkv,denkv);                                %Create sG(s).
sG=minreal(sG);                                    %Cancel common poles and zeros.
Kv=dcgain(K*sG)                                    %Display uncompensated Kv.
ess=1/Kv                                            %Display uncompensated steady-state
                                                    %error for unit ramp input.

'T(s)'                                              %Display label.
T=feedback(K*G,1)                                  %Create and display T(s).
step(T)                                             %Plot step response of uncompensated
                                                    %system.
title(['Uncompensated System with ', num2str(pos), '% Overshoot']) %Add title to uncompensated step
                                                    %response.

'Press any key to go to lead compensation'          %Display label.

pause
Ts=input('Type Desired Settling Time ');          %Input desired settling time.
                                                    %Input desired settling time.
b=input('Type Lead Compensator Zero, (s+b). b= '); %Input lead compensator zero.
                                                    %Input lead compensator zero.
done=1;                                             %Set loop flag.
while done==1                                       %Start loop for trying lead
                                                    %compensator pole.
a=input('Enter a Test Lead Compensator Pole, (s+a). a = '); %Enter test lead compensator pole.
                                                    %Enter test lead compensator pole.
numge=conv(numg,[1 b]);                            %Generate numerator of Gc(s)G(s).
denge=conv([1 a],deng);                            %Generate denominator of Gc(s)G(s).
Ge=tf(numge,denge);                                %Create Ge(s)=Gc(s)G(s).
wn=4/(Ts*z);                                       %Evaluate desired natural frequency.
clf                                                %Clear graph on screen.
rlocus(Ge)                                          %Plot compensated root locus with
                                                    %test lead compensator pole.
axis([-10,10,-10,10])                             %Change lead-compensated root locus
                                                    %axes.
sgrid(z,wn)                                        %Overlay grid on lead-compensated
                                                    %root locus.
title(['Lead-Compensated Root Locus with ', num2str(pos),...
'% Overshoot Line, Lead Pole at ', num2str(-a),...
' and Required Wn'])                               %Add title to lead-compensated root
                                                    %locus.

```

```

done=input('Are you done? (y=0,n=1) ');
end
[K,p]=rlocfind(Ge);
'Gc(s)'
Gc=tf([1 b],[1 a])
'Gc(s)G(s)'
Ge
'Closed-loop poles = '
p
f=input('Give pole number that is operating point ');
'Summary of estimated specifications for selected point on lead'
'compensated root locus'
operatingpoint=p(f)
gain=K
estimated_settling_time=4/abs(real(p(f)))
estimated_peak_time=pi/abs(imag(p(f)))
estimated_percent_overshoot=pos
estimated_damping_ratio=z
estimated_natural_frequency=sqrt(real(p(f))^2+imag(p(f))^2)
s=tf([1 0],1);
sGe=s*Ge;
sGe=minreal(sGe);
Kv=dcgain(K*sGe)
ess=1/Kv
'T(s)'
T=feedback(K*Ge,1)
'Press any key to continue and obtain the lead-compensated step'
'response'
pause
step(T)
title(['Lead-Compensated System with ',num2str(pos),'% Overshoot'])
pause
'Digital design'
T=0.01
clf
'Gc(s) in polynomial form'
Gcs=K*Gc
'Gc(s) in polynomial form'
Gcszpk=zpk(Gcs)
'Gc(z) in polynomial form via Tustin Transformation'
Gcz=c2d(Gcs,T,'tustin')
'Gc(z) in factored form via Tustin Transformation'
Gczzpk=zpk(Gcz)
'Gp(s) in polynomial form'
Gps=G

```

```

'Gp(s) in factored form'           %Print label.
Gpszpk=zpk(Gps)                   %Create Gp(s) in factored form.
'Gp(z) in polynomial form'        %Print label.
Gpz=c2d(Gps,T,'zoh')              %Form Gp(z) via zoh transformation.
'Gp(z) in factored form'          %Print label.
Gpzpk=zpk(Gpz)                    %Form Gp(z) in factored form.
pole(Gpz)                          %Find poles of Gp(z).
Gez=Gcz*Gpz;                       %Form Ge(z) = Gc(z)Gp(z).
'Ge(z) = Gc(z)Gp(z) in factored form' %Print label.
Gezpk=zpk(Gez)                    %Form Ge(z) in factored form.
'z-1'                              %Print label.
zml=tf([1 -1],1,T)                %Form z-1.
zmlGez=minreal(zml*Gez,.00001);    %Cancel common factors.
'(z-1)Ge(z)'                      %Print label.
zmlGezpk=zpk(zmlGez)              %Form & display (z-1)Ge(z) in
                                  %factored form.
pole(zmlGez)                      %Find poles of (z-1)Ge(z).
Kv=10*dcgain(zmlGez)              %Find Kv.
Tz=feedback(Gez,1)                %Find closed-loop
                                  %transfer function, T(z)
step(Tz)                          %Find step reponse.
title('Closed-Loop Digital Step Response') %Add title to step response.

```

**Computer response:**

ans =

Design of digital lead compensation

ans =

Uncompensated System

ans =

G(s)

Transfer function:

$$\frac{1}{s^3 + 13s^2 + 40s}$$

Type desired percent overshoot 10  
 Select a point in the graphics window

selected\_point =

-1.6435 + 2.2437i

ans =

Closed-loop poles =

p =

$$\begin{aligned} & -9.6740 \\ & -1.6630 + 2.2492i \\ & -1.6630 - 2.2492i \end{aligned}$$

Give pole number that is operating point 2

ans =

Summary of estimated specifications for selected point on

ans =

uncompensated root locus

operatingpoint =

-1.6630 + 2.2492i

gain =

75.6925

estimated\_settling\_time =

2.4053

estimated\_peak\_time =

1.3968

estimated\_percent\_overshoot =

10

estimated\_damping\_ratio =

0.5912

estimated\_natural\_frequency =

2.7972

Kv =

1.8923

ess =

0.5285

ans =

T(s)

Transfer function:

75.69

-----  
s^3 + 13 s^2 + 40 s + 75.69

ans =



```

Press any key to go to lead compensation

Type Desired Settling Time 2
Type Lead Compensator Zero, (s+b). b= 5
Enter a Test Lead Compensator Pole, (s+a). a = 6.8
Are you done? (y=0,n=1) 0
Select a point in the graphics window

selected_point =
    -1.9709 + 2.6692i

ans =

Gc(s)

Transfer function:
    s + 5
-----
    s + 6.8

ans =

Gc(s)G(s)

Transfer function:
                s + 5
-----
s^4 + 19.8 s^3 + 128.4 s^2 + 272 s

ans =

Closed-loop poles =

p =
    -10.7971
    -5.0000
    -2.0015 + 2.6785i
    -2.0015 - 2.6785i

Give pole number that is operating point 3

ans =

Summary of estimated specifications for selected point on lead

ans =

compensated root locus

operatingpoint =
    -2.0015 + 2.6785i

gain =
    120.7142

```

```
estimated_settling_time =
    1.9985
```

```
estimated_peak_time =
    1.1729
```

```
estimated_percent_overshoot =
    10
```

```
estimated_damping_ratio =
    0.5912
```

```
estimated_natural_frequency =
    3.3437
```

```
Kv =
    2.2190
```

```
ess =
    0.4507
```

```
ans =
T(s)
```

```
Transfer function:
          120.7 s + 603.6
-----
s^4 + 19.8 s^3 + 128.4 s^2 + 392.7 s + 603.6
```

```
ans =
```

Press any key to continue and obtain the lead-compensated step

```
ans =
```

```
response
```

```
ans =
```

```
Digital design
```

```
T =
    0.0100
```

ans =

Gc(s) in polynomial form

Transfer function:

$$\frac{120.7 s + 603.6}{s + 6.8}$$

$$s + 6.8$$

ans =

Gc(s) in polynomial form

Zero/pole/gain:

$$\frac{120.7142 (s+5)}{(s+6.8)}$$

$$(s+6.8)$$

ans =

Gc(z) in polynomial form via Tustin Transformation

Transfer function:

$$\frac{119.7 z - 113.8}{z - 0.9342}$$

$$z - 0.9342$$

Sampling time: 0.01

ans =

Gc(z) in factored form via Tustin Transformation

Zero/pole/gain:

$$\frac{119.6635 (z-0.9512)}{(z-0.9342)}$$

$$(z-0.9342)$$

Sampling time: 0.01

ans =

Gp(s) in polynomial form

Transfer function:

$$\frac{1}{s^3 + 13 s^2 + 40 s}$$

ans =

Gp(s) in factored form

Zero/pole/gain:

$$\frac{1}{s (s+8) (s+5)}$$

ans =

Gp(z) in polynomial form

Transfer function:

$$\frac{1.614e-007 z^2 + 6.249e-007 z + 1.512e-007}{z^3 - 2.874 z^2 + 2.752 z - 0.8781}$$

Sampling time: 0.01

ans =

Gp(z) in factored form

Zero/pole/gain:

$$\frac{1.6136e-007 (z+3.613) (z+0.2593)}{(z-1) (z-0.9512) (z-0.9231)}$$

Sampling time: 0.01

ans =

1.0000  
0.9512  
0.9231

ans =

Ge(z) = Gc(z)Gp(z) in factored form

Zero/pole/gain:

$$\frac{1.9308e-005 (z+3.613) (z-0.9512) (z+0.2593)}{(z-1) (z-0.9512) (z-0.9342) (z-0.9231)}$$

Sampling time: 0.01

ans =

z-1

Transfer function:

$$z - 1$$

Sampling time: 0.01

ans =

(z-1)Ge(z)

Zero/pole/gain:

$$\frac{1.9308e-005 (z+3.613) (z+0.2593)}{(z-0.9342) (z-0.9231)}$$

Sampling time: 0.01

ans =

0.9342  
0.9231

Kv =

0.2219

Transfer function:

$$1.931e-005 z^3 + 5.641e-005 z^2 - 5.303e-005 z - 1.721e-005$$

---

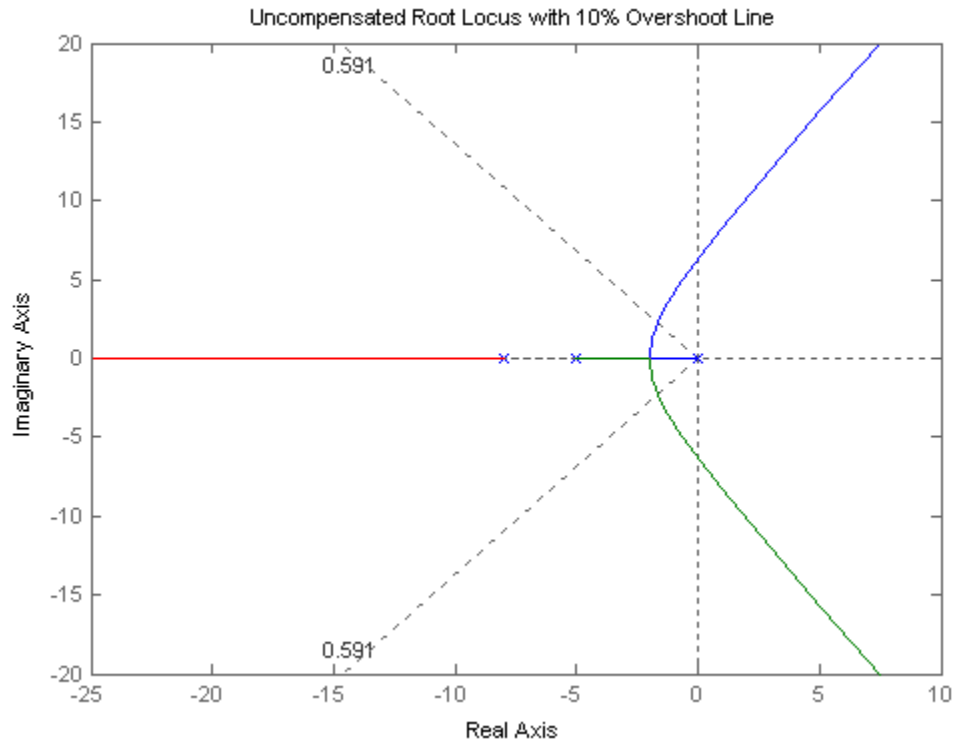

$$z^4 - 3.809 z^3 + 5.438 z^2 - 3.45 z + 0.8203$$

Sampling time: 0.01

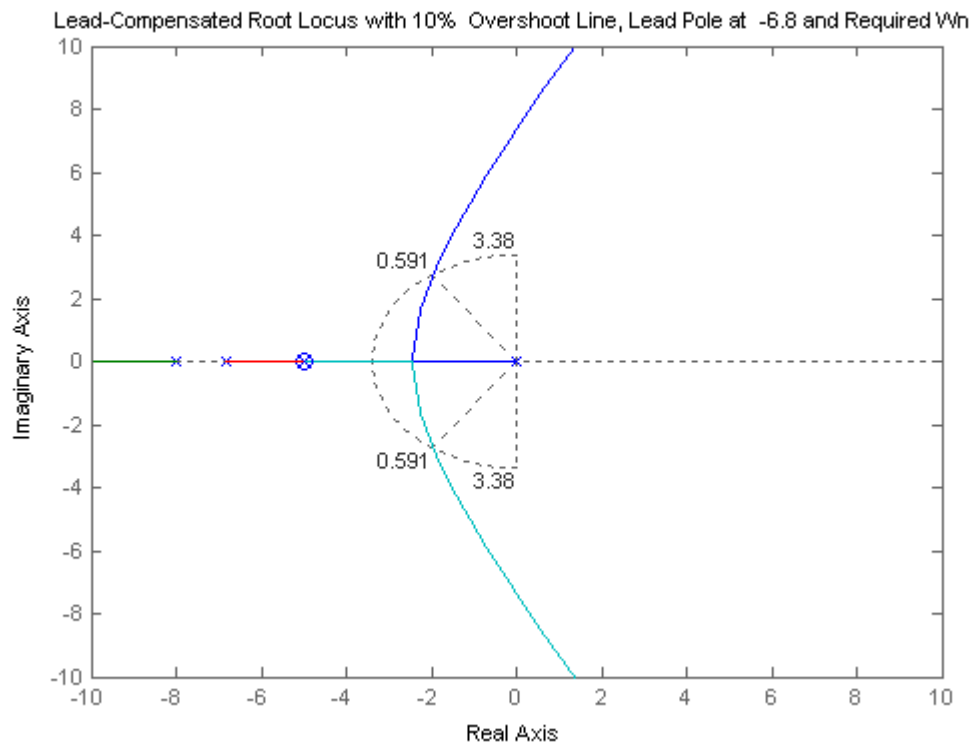
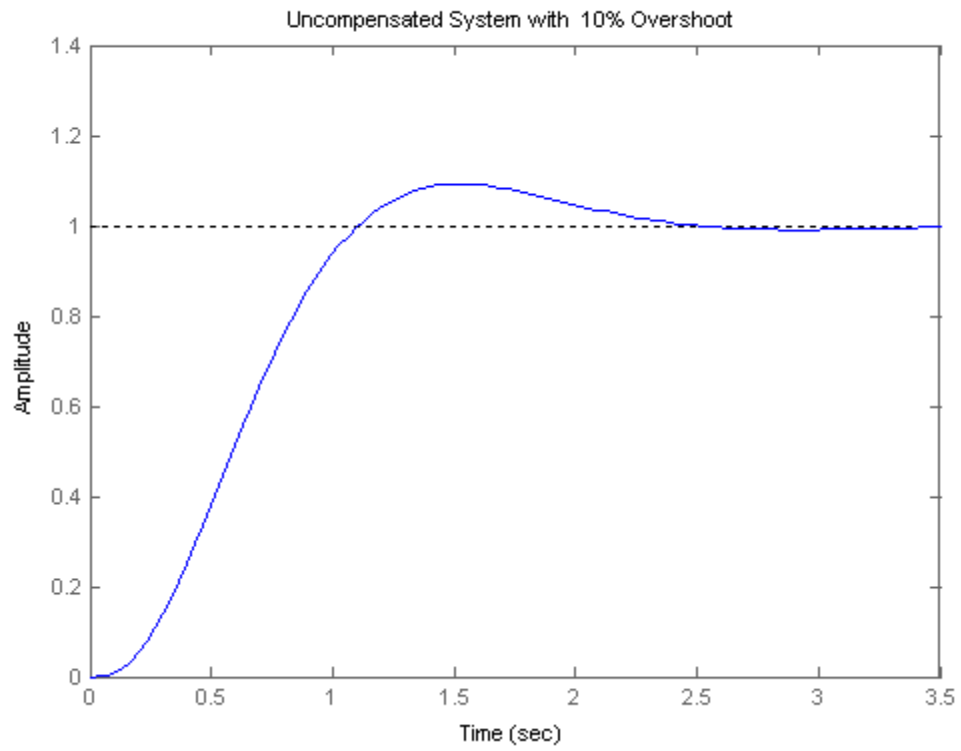

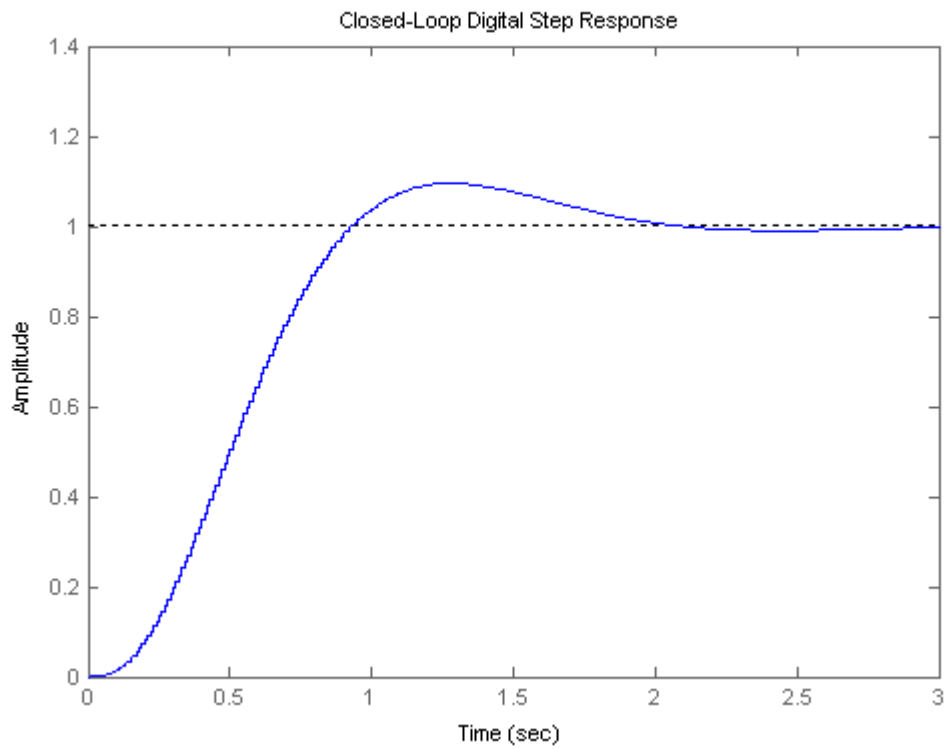
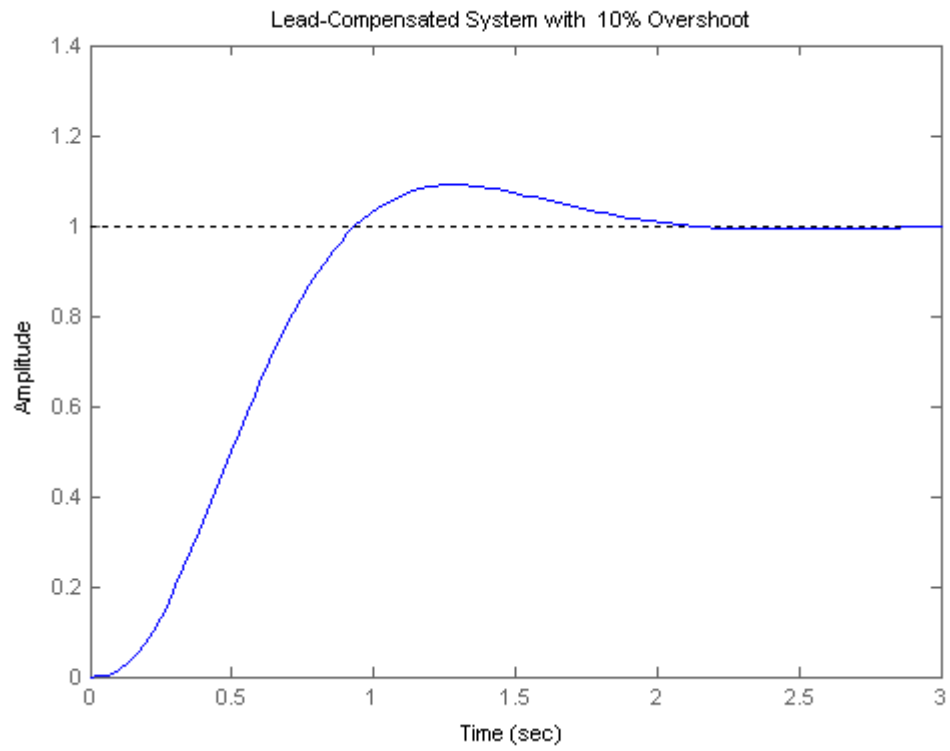

+



## SOLUTIONS TO DESIGN PROBLEMS

27.

- a. Push negative sign from vehicle dynamics to the left past the summing junction. The computer will be the area inside the large box with the inputs and outputs shown sampled.  $G(s)$  is the combined rudder actuator and vehicle dynamics. Also, the yaw rate sensor is shown equivalently before the integrator with unity feedback.

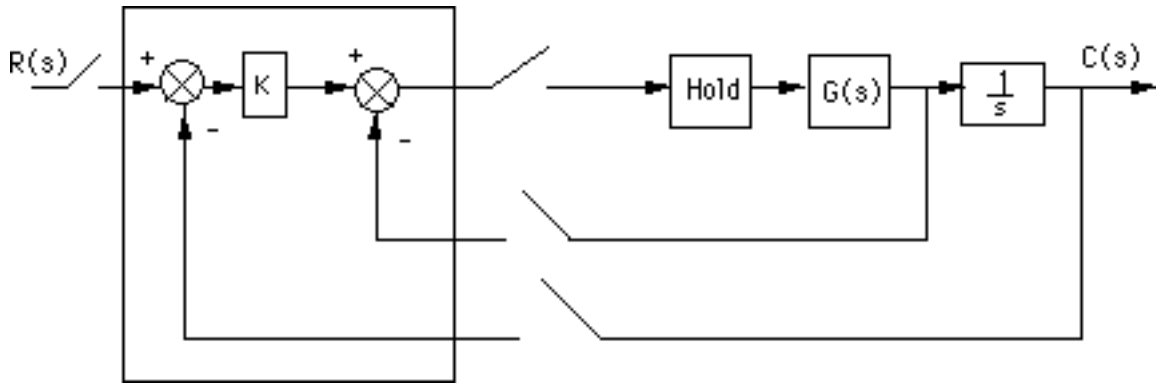

where  $G(s) = \frac{0.25(s+0.437)}{(s+2)(s+1.29)(s+0.193)}$ .

- b. Add a phantom sampler at the output and push  $G(s)$  along with its sample and hold to the right past the pickoff point.

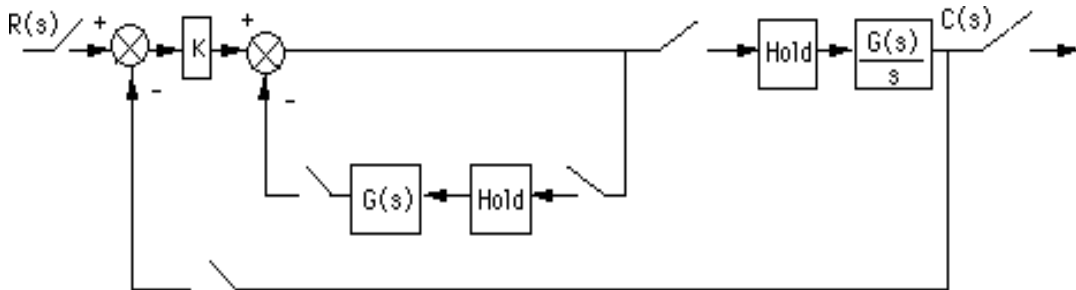

Move the outer-loop sampler to the output of  $\frac{G(s)}{s}$  and write the z transforms of the transfer functions.

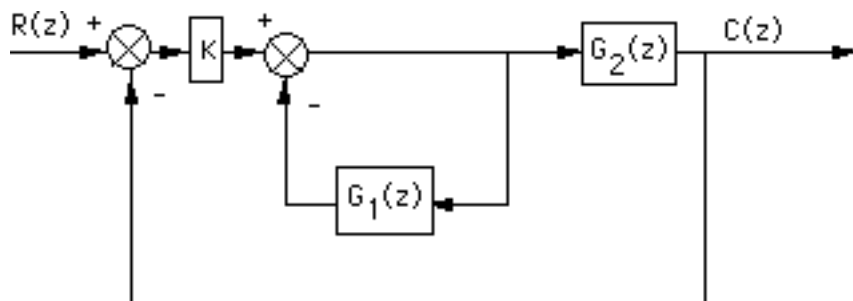

where



$$G_1(s) = (1 - e^{-Ts}) \frac{0.25(s+0.437)}{s(s+2)(s+1.29)(s+0.193)}$$

and

$$G_2(s) = (1 - e^{-Ts}) \frac{0.25(s+0.437)}{s^2(s+2)(s+1.29)(s+0.193)}$$

Now find the z transforms of  $G_1(s)$  and  $G_2(s)$ . For  $G_1(z)$ .

Since

$$\frac{0.25(s+0.437)}{s(s+2)(s+1.29)(s+0.193)} = 0.15228 \frac{1}{s+2} - 0.15944 \frac{1}{s+0.193} - 0.21224 \frac{1}{s+1.29} + 0.2194 \frac{1}{s}$$

$$G_1(z) = \frac{z-1}{z} \left( 0.15228 \frac{z}{z-e^{-2T}} - 0.15944 \frac{z}{z-e^{-0.193T}} - 0.21224 \frac{z}{z-e^{-1.29T}} + 0.2194 \frac{z}{z-1} \right)$$

$T = 0.1$

$$G_1(z) = \frac{0.0011305z^2 - 6.0812 \times 10^{-5}z - 0.00097764}{(z-0.81873)(z-0.87897)(z-0.98089)}$$

For  $G_2(z)$ :

Since

$$\frac{0.25(s+0.437)}{s^2(s+2)(s+1.29)(s+0.193)} = -0.076142 \frac{1}{s+2} + 0.82613 \frac{1}{s+0.193} + 0.16453 \frac{1}{s+1.29}$$

$$- 0.91452 \frac{1}{s} + 0.2194 \frac{1}{s^2}$$

$$G_2(z) = \frac{z-1}{z} \left( -0.076142 \frac{z}{z-e^{-2T}} + 0.82613 \frac{z}{z-e^{-0.193T}} + 0.16453 \frac{z}{z-e^{-1.29T}} \right.$$

$$\left. - 0.91452 \frac{z}{z-1} + 0.2194 \frac{Tz}{[z-1]^2} \right)$$

$T = 0.1$

$$G_2(z) = \frac{3.8642 \times 10^{-5}z^3 + 0.00010636z^2 - 0.00010404z - 3.1765 \times 10^{-5}}{(z-1)(z-0.81873)(z-0.87897)(z-0.98089)}$$

Now find the closed-loop transfer function. First find the equivalent forward transfer function.

$$G_e(z) = K \frac{G_2(z)}{1+G_1(z)}$$

$$G_e = 3.8642 \times 10^{-5} \frac{(z+0.24807)(z-0.95724)(z+3.4616)K}{(z-1)(z-0.75327)(z^2-1.9253z+0.93574)}$$

Thus,

$$T(z) = \frac{G_e(z)}{1+G_e(z)}$$

Substituting values,

$$T = 3.8642 \times 10^{-5} \frac{(z+0.24807)(z-0.95724)(z+3.4616)K}{z^4 + (3.8642 \times 10^{-5}K - 3.6786)z^3 + (0.00010636K + 5.0646)z^2 - (0.00010404K + 3.0909)z + (-3.1765 \times 10^{-5}K + 0.70487)}$$

c. Using  $G_e(z)$ , plot the root locus and see where it crosses the unit circle.

$$G_e = 3.8642 \times 10^{-5} \frac{(z + 0.24807)(z - 0.95724)(z + 3.4616)K}{(z - 1)([z - 0.75327][z - 0.96266 + 0.095008i][z - 0.96266 - 0.095008i])}$$

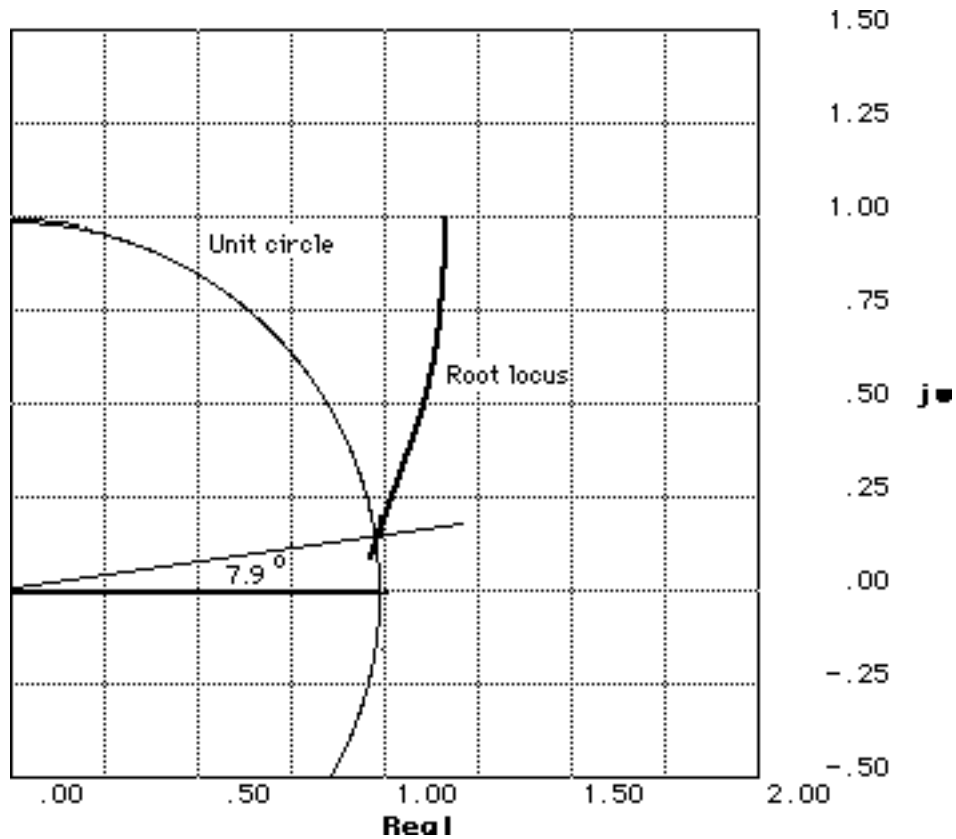

The root locus crosses the unit circle when  $3.8642 \times 10^{-5}K = 5.797 \times 10^{-4}$ , or  $K = 15$ .

28.

a. First find  $G(z)$ .

$$G(z) = K \frac{z-1}{z} z \left\{ \frac{1}{s^2 (s^2 + 7s + 1220)} \right\}$$

$$= K \frac{z-1}{z} z \left\{ 6.7186 \times 10^{-7} \left( \frac{7(s+3.5) - 34.4 \sqrt{1207.8}}{(s+3.5)^2 + 1207.8} - 7 \frac{1}{s} + 1220 \frac{1}{s^2} \right) \right\}$$

For  $T = 0.1$ ,

$$= K \frac{z-1}{z} \left\{ 6.7186 \times 10^7 \left( 7 \frac{z^2 + 0.66582z}{z^2 + 1.3316z + 0.49659} + 7.8472 \frac{z}{z^2 + 1.3316z + 0.49659} - 7 \frac{z}{z-1} + 122 \frac{z}{(z-1)^2} \right) \right\}$$

$$G(z) = K 7.9405 \times 10^{-5} \frac{(z + 0.63582 + 0.49355i)(z + 0.63582 - 0.49355i)}{(z - 1)([z + 0.66582 + 0.2308i][z + 0.66582 - 0.2308i])}$$

b.

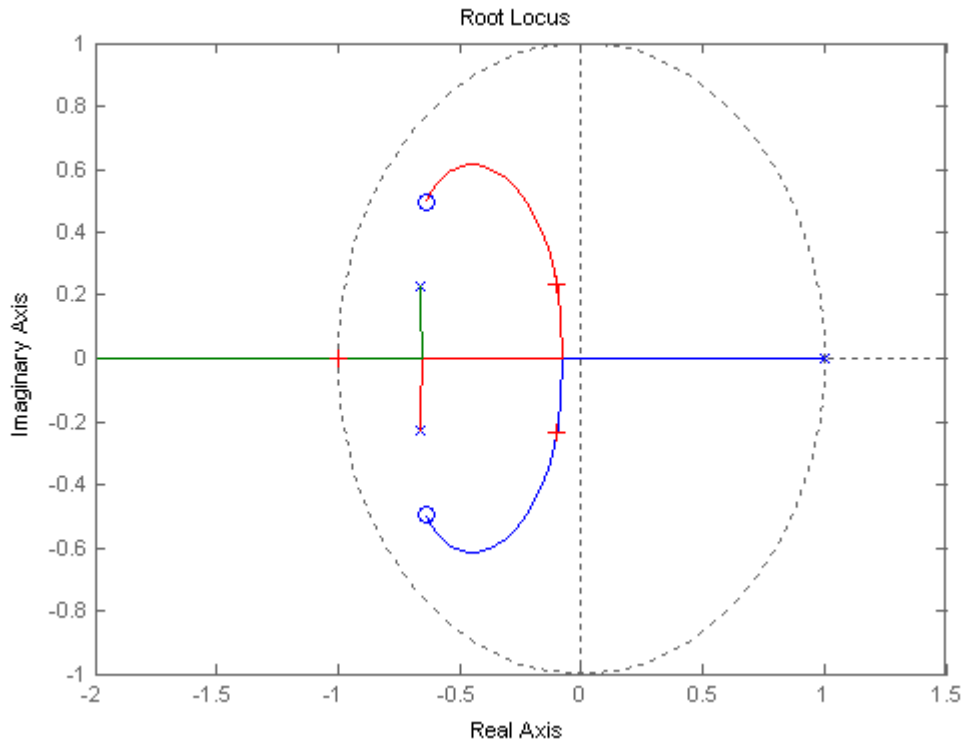

c. The root locus intersects the unit circle at  $-1$  with a gain,  $7.9405 \times 10^{-5} K = 10866$ , or  $0 < K < 136.84 \times 10^6$ .

d.

**Program:**

```
%Digitize G1(s) preceded by a sample and hold
numg1=1;
deng1=[1 7 1220 0];
'G1(s)'
G1s=tf(numg1,deng1)
'G(z)'
Gz=c2d(G1s,0.1,'zoh')
[numgz,dengz]=tfdata(Gz,'v');
'Zeros of G(z)'
roots(numgz)
'Poles of G(z)'
roots(dengz)
%Plot root locus
rlocus(Gz)
title(['Root Locus'])
[K,p]=rlocfind(Gz)
```

**Computer response:**

ans =

G1(s)

Transfer function:

```
1
-----
s^3 + 7 s^2 + 1220 s
```

ans =

G(z)

Transfer function:  

$$\frac{7.947e-005 z^2 + 0.0001008 z + 5.15e-005}{z^3 + 0.3316 z^2 - 0.8351 z - 0.4966}$$

Sampling time: 0.1

ans =

Zeros of G(z)

ans =

-0.6345 + 0.4955i  
 -0.6345 - 0.4955i

ans =

Poles of G(z)

ans =

1.0000  
 -0.6658 + 0.2308i  
 -0.6658 - 0.2308i

Select a point in the graphics window

selected\_point =

-0.9977

K =

1.0885e+004

p =

-0.9977  
 -0.0995 + 0.2330i  
 -0.0995 - 0.2330i

See part (b) for root locus plot.

29.

a. First find G(z).  $G(z) = K \frac{z-1}{z} z \left\{ \frac{20000}{s^2(s+100)} \right\} = K \frac{z-1}{z} z \left\{ 2 \frac{1}{s+100} - 2 \frac{1}{s} + 200 \frac{1}{s^2} \right\}$

For T = 0.01,  $G(z) = K \frac{z-1}{z} \left( -2 \frac{z}{z-1} + 2 \frac{z}{[z-1]^2} + 2 \frac{z}{z-0.36788} \right)$

$= 0.73576K \frac{z+0.71828}{(z-1)(z-0.36788)}$

b. Plotting the root locus. Finding the intersection with the unit circle yields  $0.73576K = 1.178$ . Thus,  $0 < K < 1.601$  for stability.

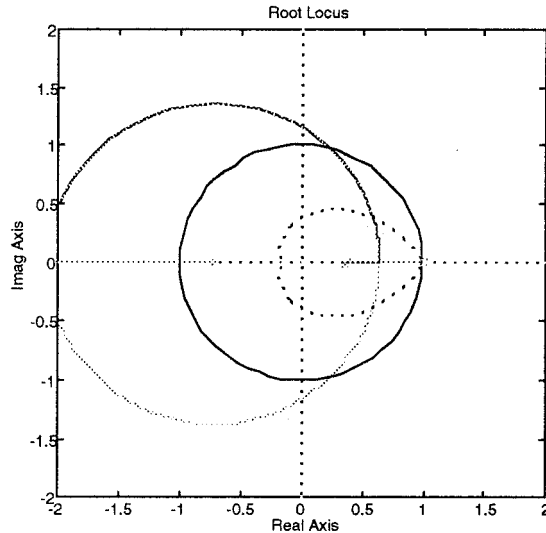

c. Using the root locus, we find the intersection with the 15% overshoot curve ( $\zeta = 0.517$ ) at  $0.5955 + j0.3747$  with  $0.73576K = 0.24$ . Thus  $K = 0.326$ .

d.

**Program:**

```
%Digitize G1(s) preceded by a sample and hold
numg1=20000;
deng1=[1 100 0];
'G1(s)'
G1s=tf(numg1,deng1)
'G(z)'
Gz=c2d(G1s,0.01,'zoh')
[numgz,dengz]=tfdata(Gz,'v');
'Zeros of G(z)'
roots(numgz)
'Poles of G(z)'
roots(dengz)
%Input transient response specifications
Po=input('Type %OS ');
%Determine damping ratio
z=(-log(Po/100))/(sqrt(pi^2+log(Po/100)^2))
%Plot root locus
rlocus(Gz)
zgrid(z,0)
title(['Root Locus'])
[K,p]=rlocfind(Gz) %Allows input by selecting point on graphic.
```

**Computer response:**

ans =

G1(s)

Transfer function:

```
20000
-----
s^2 + 100 s
```

ans =

G(z)

Transfer function:  

$$\frac{0.7358 z + 0.5285}{z^2 - 1.368 z + 0.3679}$$

Sampling time: 0.01

ans =

Zeros of G(z)

ans =

-0.7183

ans =

Poles of G(z)

ans =

1.0000  
0.3679

Type %OS 15

z =

0.5169

Select a point in the graphics window

selected\_point =

0.5949 + 0.3888i

K =

0.2509

p =

0.5917 + 0.3878i  
0.5917 - 0.3878



The characteristic equation for this system is:

$$1 + G(z) = 1 + \frac{(0.0031z^2 + 0.0031z + 0.0104)K}{(z - 0.953)(z - 0.8279)} = 0 \text{ or}$$

$$(1 + 0.0031K)z^2 + (0.0031K - 1.7809)z + (0.789 + 0.0104K) = 0$$

We use now the bilinear transformation by substituting  $z = \frac{s'+1}{s'-1}$

$$(1 + 0.0031K) \frac{(s'+1)^2}{(s'-1)^2} + (0.0031K - 1.7809) \frac{s'+1}{s'-1} + (0.789 + 0.0104K) = 0$$

giving

$$(0.0081 + 0.0166K)s'^2 + (0.422 - 0.0146K)s' + (3.5699 + 0.0104K) = 0$$

The Routh array is

$s'^2$	$0.0081 + 0.0166K$	$3.5699 + 0.0104K$
$s'$	$0.422 - 0.0146K$	
1	$3.5699 + 0.0104K$	

The first column of the array will be  $>0$  when  $K > 0$  and from the second row

$$K < \frac{0.422}{0.0146} = 28.9041$$

So the system is closed loop stable when  $0 < K < 28.9041$ .

32.

a. In Problem 31 we found that for this system with  $T=1\text{sec}$ ,  $G(z) = \frac{K(0.0031z^2 + 0.0031z + 0.0104)}{(z - 0.953)(z - 0.8279)}$

In MATLAB this system is defined as  $G=\text{tf}(0.0031*[1 \ 1 \ 3.3548],\text{conv}([1 \ -0.953],[1 \ -0.8279]),1)$ . Invoking SISOTOOL one gets



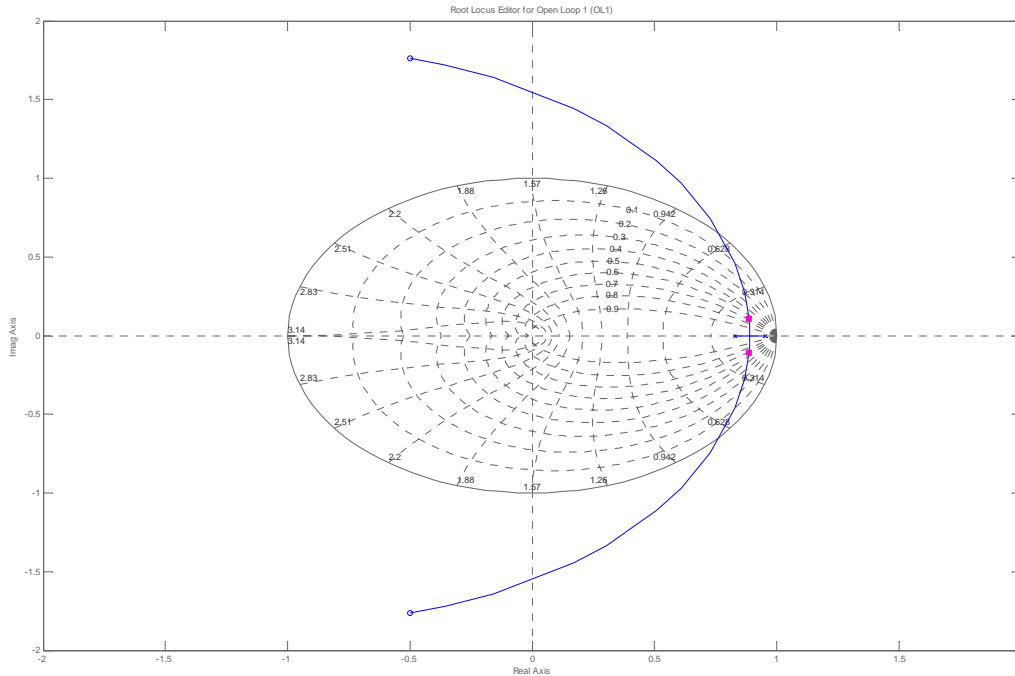

b.  $\zeta = 0.7$  is achieved when  $K=0.928$

c. The closed loop poles are located at  $0.866 \pm j0.103$ . The radial distance from the origin is

$$r = \sqrt{0.866^2 + 0.103^2} = 0.872, \text{ so } T_s = \frac{-4T}{\ln(r)} = 29.2 \text{ sec. The radial angle from the origin is}$$

$$\theta_1 = \tan^{-1} \frac{0.103}{0.866} = 6.8^\circ = 0.12 \text{ rad, so } \frac{T_p}{T} = \frac{\pi}{\theta_1} = \frac{\pi}{0.12} = 26.54 \text{ or } T_p = 26.54 \text{ sec}$$

d. We have that  $K_p = \lim_{z \rightarrow 1} G(z) = \lim_{z \rightarrow 1} \frac{(0.928)(0.0031)(z^2 + z + 3.3548)}{(z - 0.953)(z - 0.8279)} = 1.905$ . The steady state

error is  $e_{ss} = \frac{1}{1 + K_p} = 0.344$ . Then  $c(\infty) = 1 - 0.344 = 0.655$

e.

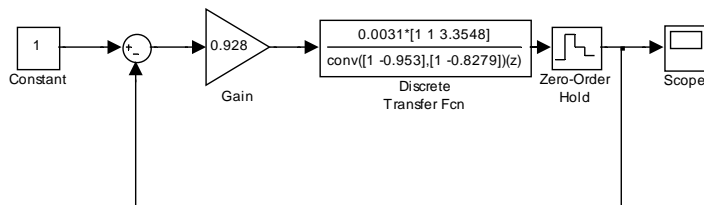

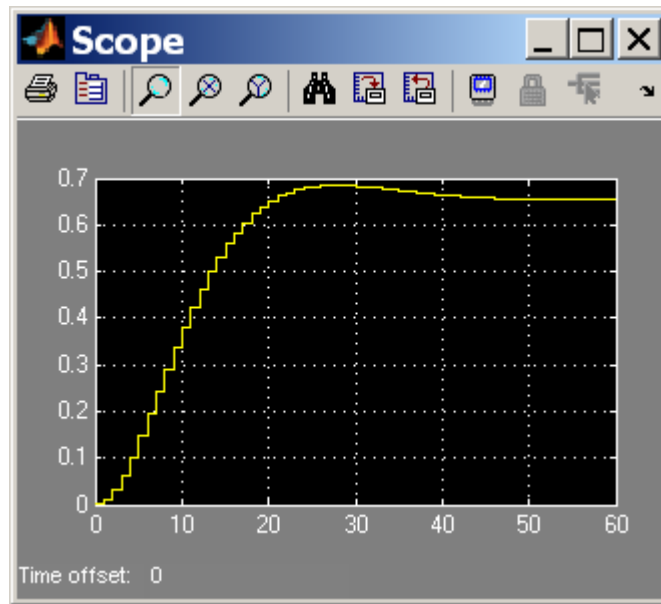

33.

a. A bode plot of the open loop transmission  $L(s) = M(s)P(s)$  shows that the crossover frequency for this system is  $\omega_c = 0.726 \frac{\text{rad}}{\text{sec}}$ . The recommended range for the sampling frequency is:

$$0.2066 \text{ sec} = \frac{0.15}{\omega_c} < T < \frac{0.5}{\omega_c} = 0.6887 \text{ sec} . \text{ Arbitrarily we choose } T = 0.25 \text{ sec} .$$

b. Substituting  $s = 8 \frac{z-1}{z+1}$  into  $M(s)$ , after algebraic manipulations we get

$$M(z) = \frac{0.07278(z^2 + 0.3386z - 0.6614)}{z^2 - 1.935z + 0.9347}$$

c.

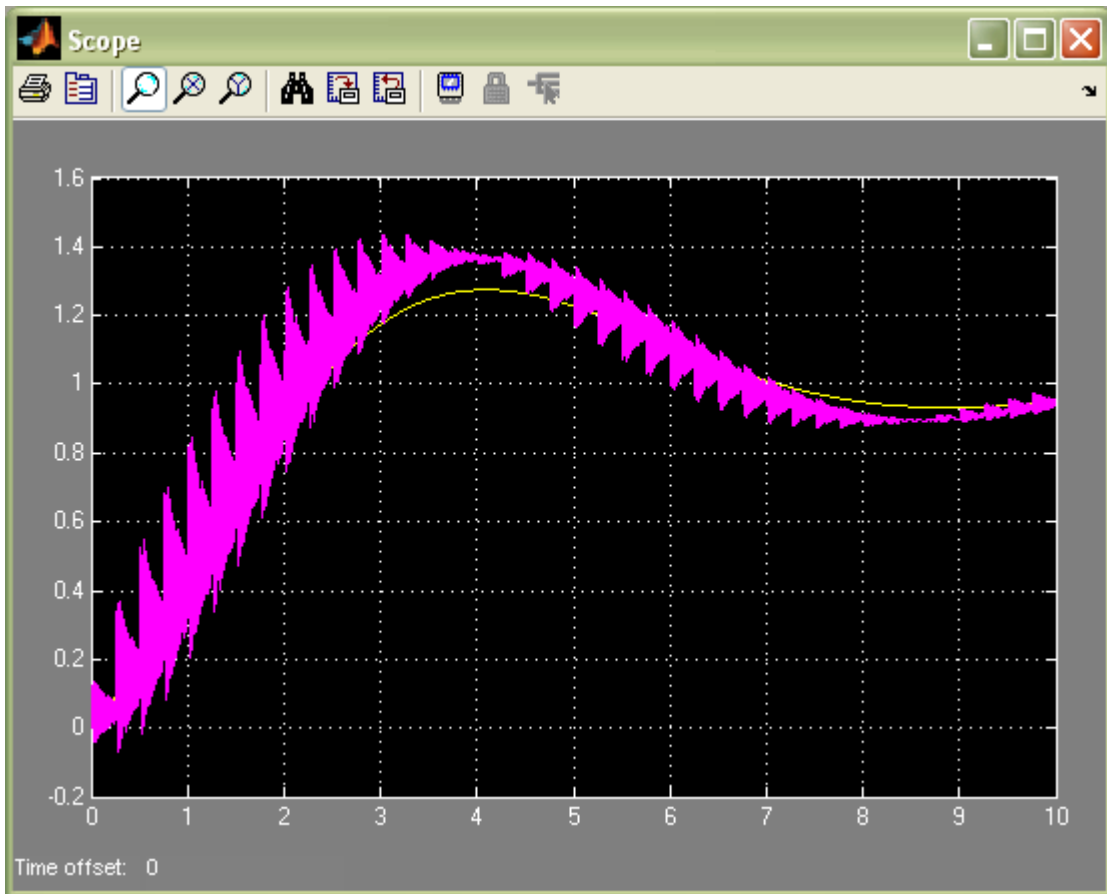
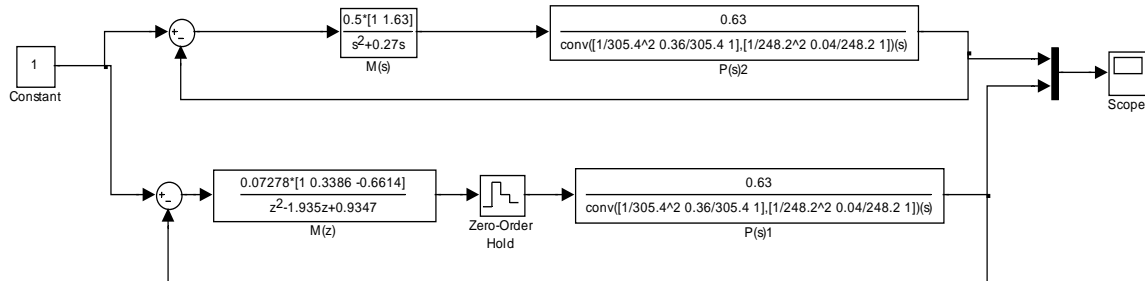

The output of the system exhibits oscillations caused by a plant high frequency resonance. This problem can be improved by using other discretization techniques.

34.

a. A bode plot of the open loop transmission  $L(s) = G_c(s)G(s)$  shows that the crossover frequency for this system is  $\omega_c = 9.9 \frac{rad}{sec}$ . The recommended range for the sampling frequency is:

$$0.015 \text{ sec} = \frac{0.15}{\omega_c} < T < \frac{0.5}{\omega_c} = 0.051 \text{ sec} . \text{ Arbitrarily we choose } T = 0.02 \text{ sec} .$$

b. Substituting  $s = 8 \frac{z-1}{z+1}$  into  $G_c(s)$ , after algebraic manipulations we get

$$G_c(z) = \frac{0.5047z - 0.4948}{z - 0.999}$$

c.

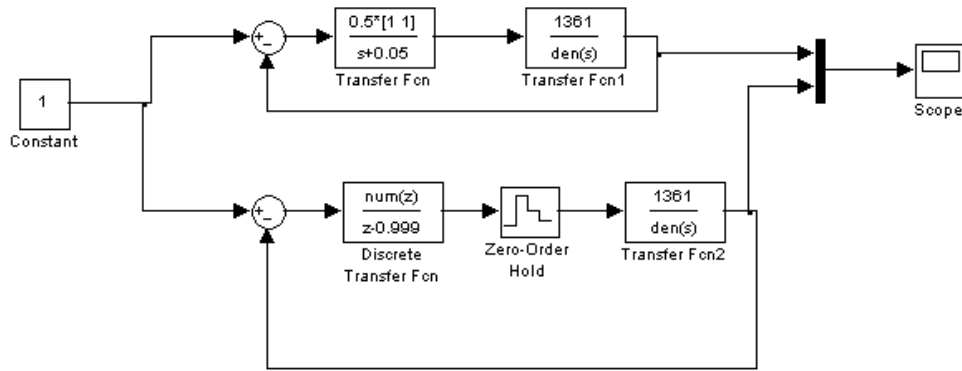

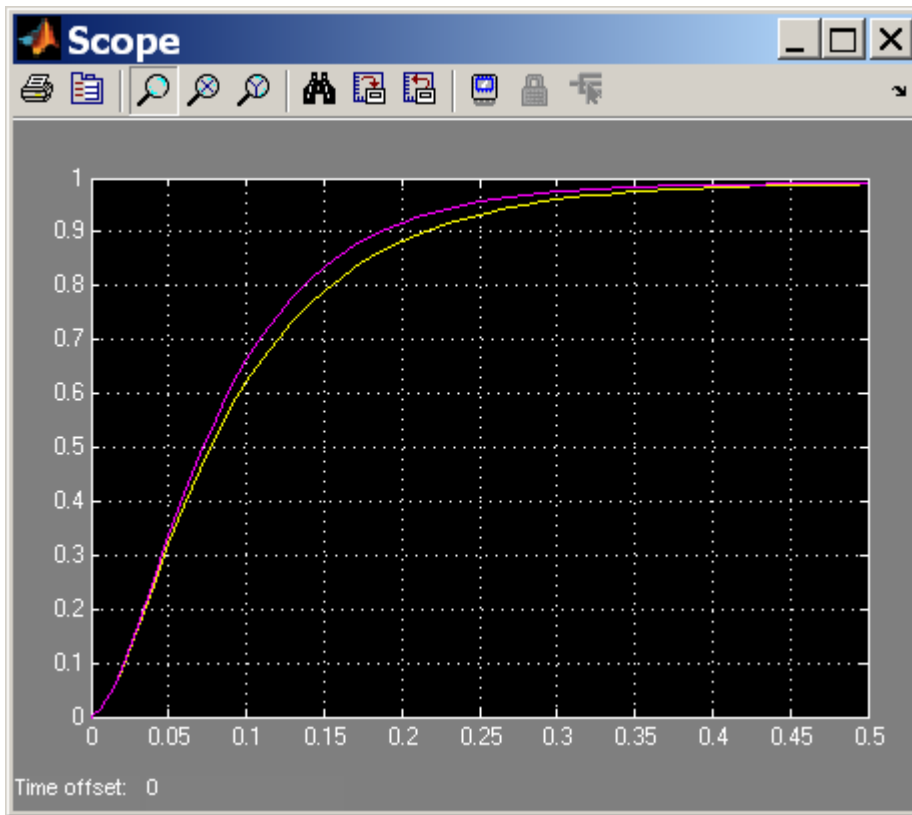

35.

a. With the zero order hold the open loop transfer function is

$$\begin{aligned}
 G_1(s) &= \frac{(1 - e^{-0.5s})K}{s(s + 0.08)(s + 2)(s + 5)} \\
 &= (1 - e^{-0.5s})K \left[ \frac{1.25}{s} - \frac{1.3233}{s + 0.08} + \frac{0.0868}{s + 2} - \frac{0.0136}{s + 5} \right] \\
 G(z) &= K \frac{z - 1}{z} \left[ \frac{1.25z}{z - 1} - \frac{1.3233z}{z - 0.961} + \frac{0.0868z}{z - 0.368} - \frac{0.0136z}{z - 0.0821} \right] \\
 &= \frac{-1 \times 10^{-4} K (z^3 - 94z^2 - 174z - 16)}{(z - 0.0821)(z - 0.368)(z - 0.961)} = \frac{-1 \times 10^{-4} K (z^3 - 94z^2 - 174z - 16)}{z^3 - 1.411z^2 + 0.4628z - 0.02903}
 \end{aligned}$$

In MATLAB this system is defined as `G=tf(-1e-4*[1 -94 -174 -16],[1 -1.411 0.4628 -0.02903],0.5)`. Invoking `SISOTOOL` one gets

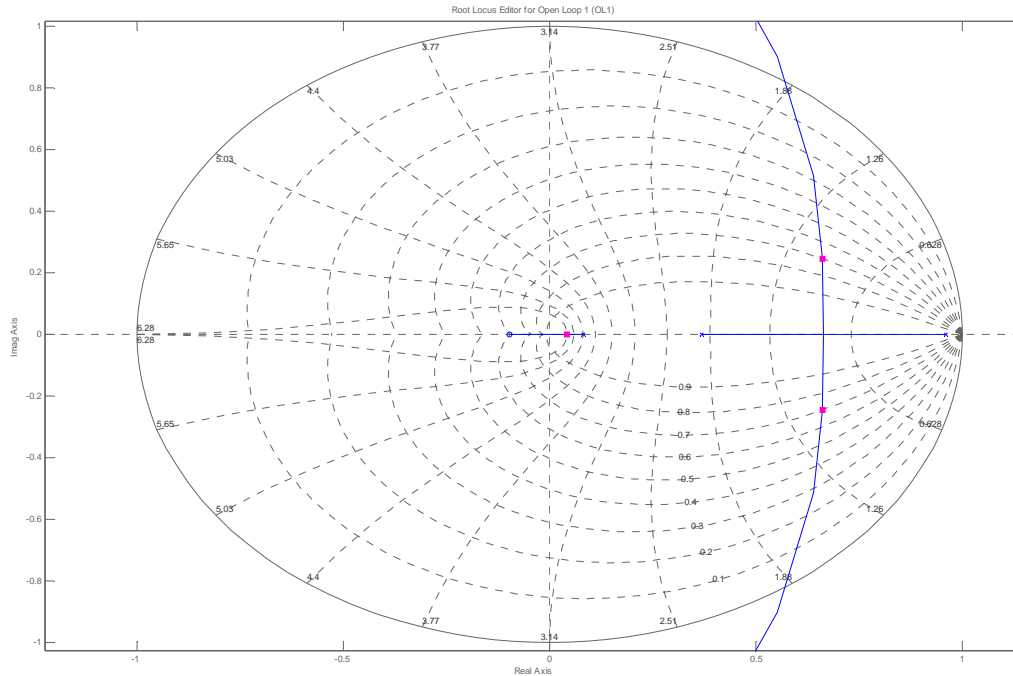

b.  $\zeta = 0.7$  is achieved when  $K=5.15$

c. The closed loop poles are located at  $0.661 \pm j0.247$ . The radial distance from the origin is

$$r = \sqrt{0.661^2 + 0.247^2} = 0.706, \text{ so } T_s = \frac{-4T}{\ln(r)} = 5.75 \text{ sec. The radial angle from the origin is}$$

$$\theta_1 = \tan^{-1} \frac{0.247}{0.661} = 20.49^\circ = 0.36 \text{ rad, so } \frac{T_p}{T} = \frac{\pi}{\theta_1} = \frac{\pi}{0.36} = 8.8 \text{ or } T_p = 4.4 \text{ sec}$$

d. We have that  $K_p = \lim_{z \rightarrow 1} G(z) = \frac{(5.15)(-1 \times 10^{-4})(1 - 94 - 174 - 16)}{(1 - 1.411 + 0.4628 - 0.02903)} = 6.4$ . The steady state error is

$$e_{ss} = \frac{1}{1 + K_p} = 0.135. \text{ Then } c(\infty) = 1 - 0.135 = 0.865$$

e.

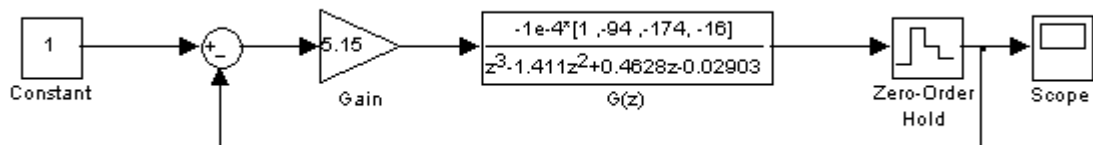

36.

$$G_{PID}(s) = \frac{0.5857(s + 0.19)(s + 0.01)}{s}$$

Substituting Eq. (13.88) with  $T = 1/3$  second,

$$G_c(z) = \frac{3.632z^2 - 7.028z + 3.397}{z^2 - 1} = \frac{3.632(z - 0.9967)(z - 0.9386)}{(z + 1)(z - 1)}$$

Drawing the flow diagram yields

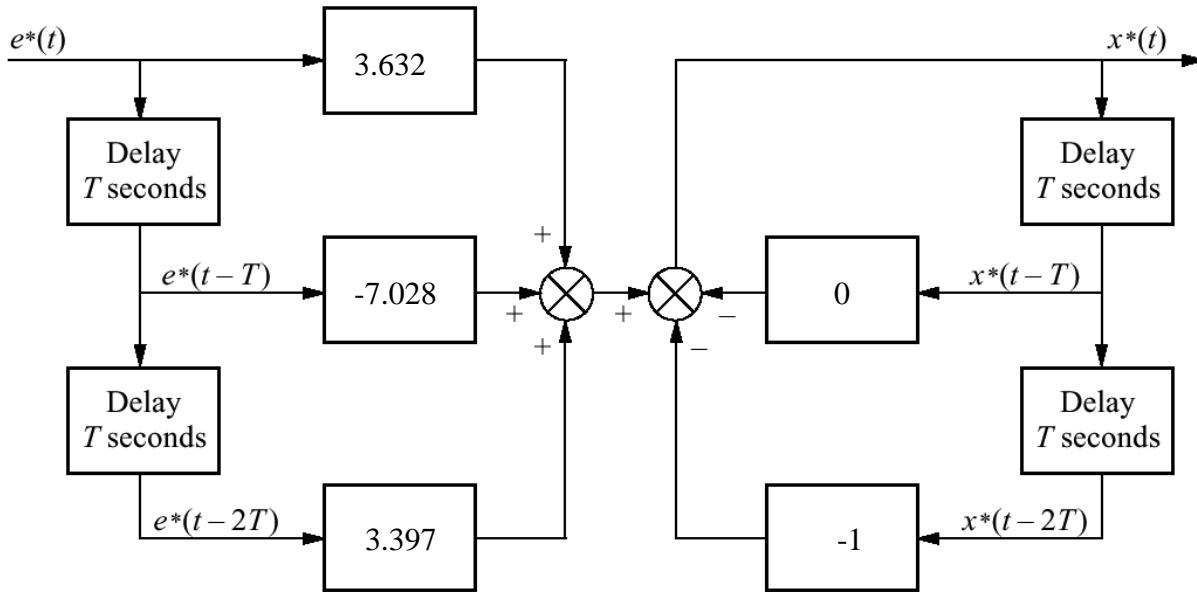
 $T = 1/3$  second

37.

a. The pulse transfer function for the plant is  $G_p(z) = \frac{z-1}{z} Z \left\{ \frac{1}{s^2} \right\} = \frac{T}{z-1}$ . The desired

$$T(z) = z^{-1}, \text{ so the compensator is } G_c(z) = \frac{1}{G_p(z)} \frac{T(z)}{1-T(z)} = \frac{1}{T}$$

b. The steady state error constant is given by  $K_v = \frac{1}{T} \lim_{z \rightarrow 1} (z-1) \frac{1}{z-1} = \frac{1}{T}$ . So the steady

state error for a ramp input is  $e(\infty) = \frac{1}{K_p} = T$

c. The simulations diagram is shown next

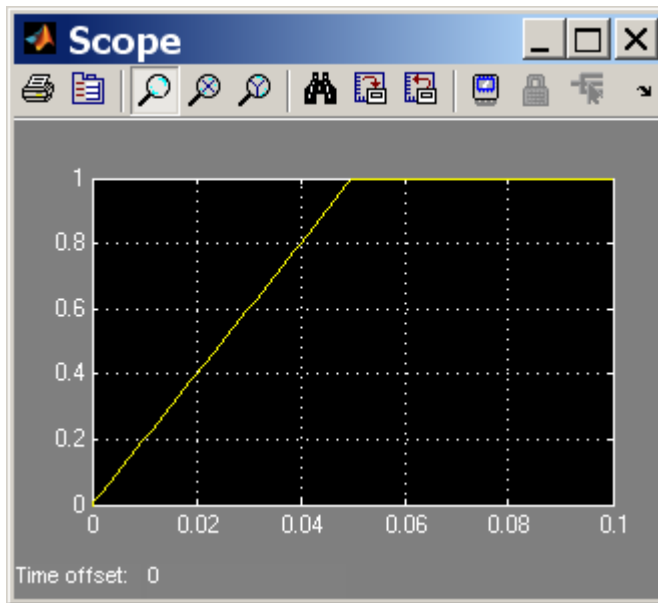
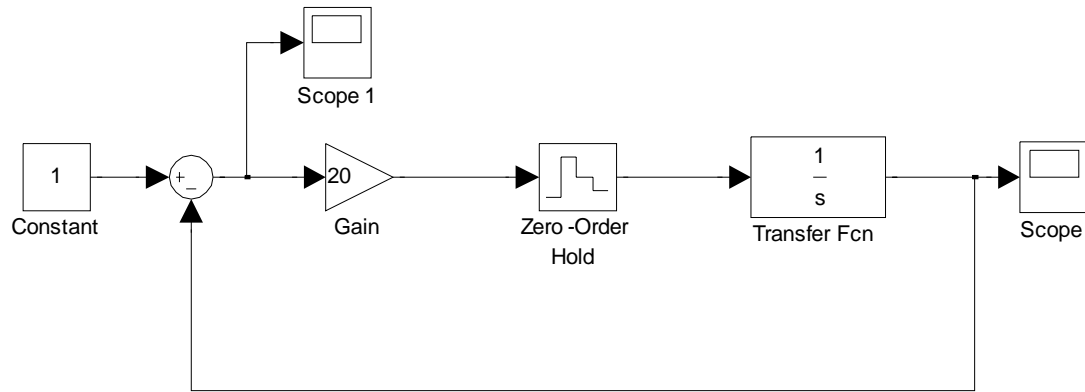

For a step input, the system reaches steady state within one sample.

For a ramp input the error signal is displayed:

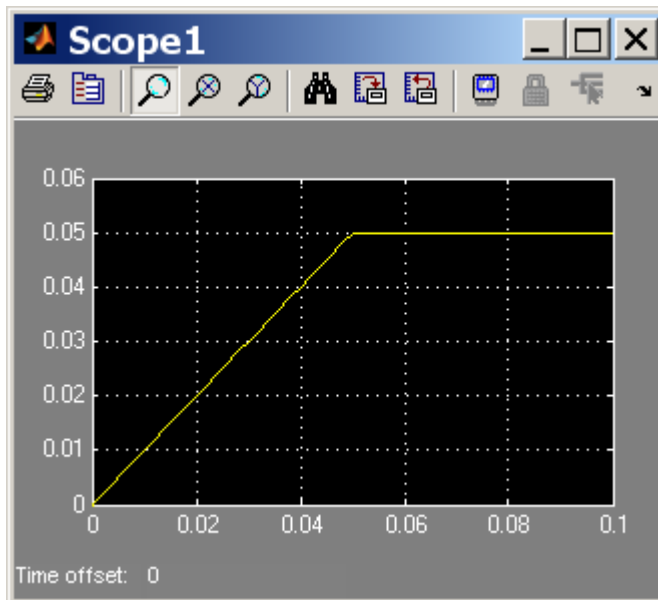



38.

**Block Diagram**

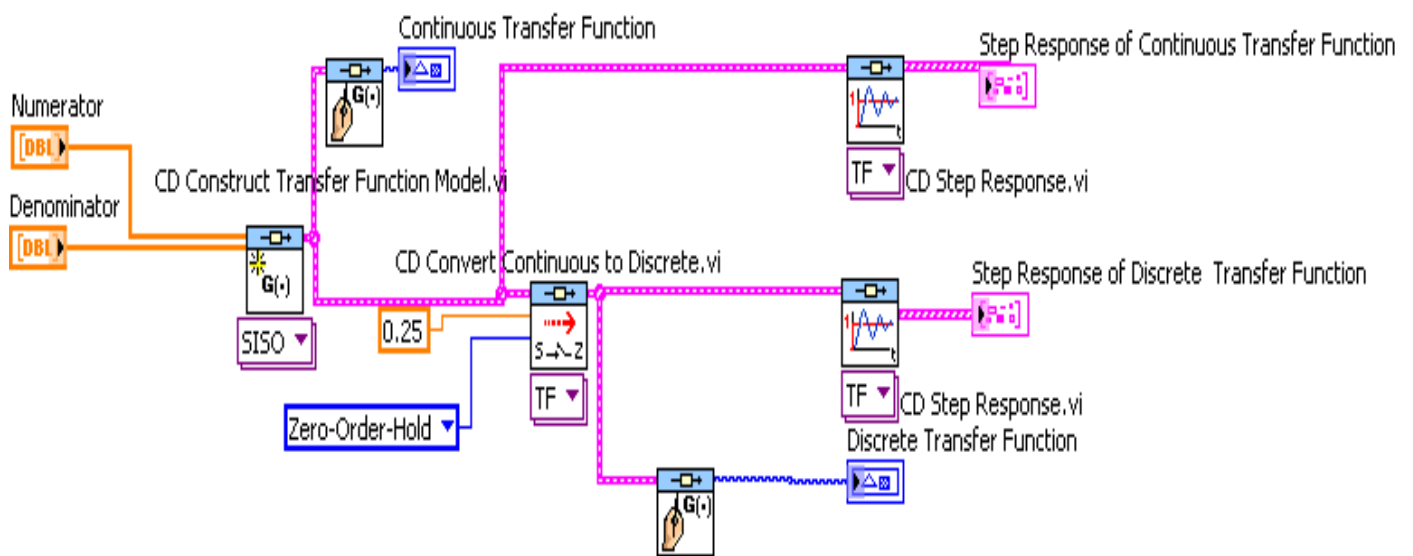

**Front Panel**

INPUTS

Enter the Numerator and Denominator Polynomials of the Continuous Time Transfer Function

<p>Numerator</p> <p>0 8 0 0</p> <p>Denominator</p> <p>0 4 1 0</p>	<p>Continuous Transfer Function</p> $\frac{8}{s + 4}$	<p>Discrete Transfer Function</p> $\frac{1.26424}{z - 0.367879}$
---	---	--

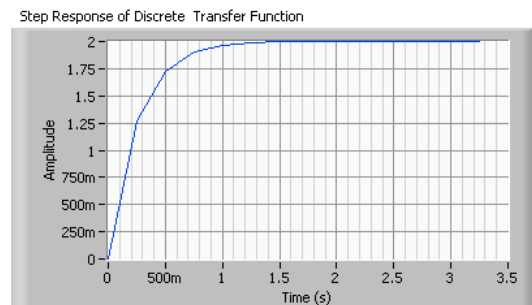
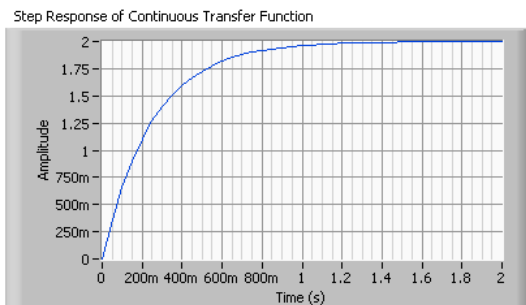

39.

**Front panel**

Enter Numerator and Denominator Polynomial of the Discrete Transfer Function

Numerator 2

0.5 1 0

Denominator 2

0.19 -1 1

Discrete Transfer Function 2

$$\frac{z + 0.5}{z^2 - z + 0.19}$$

K Value  
0.308225

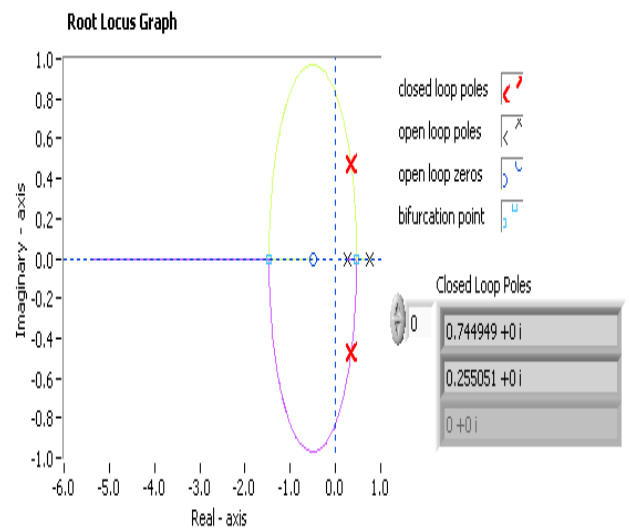

**Note: K=0.3082 coincides with the answer for Skill-Assessment Exercise 13.8.**

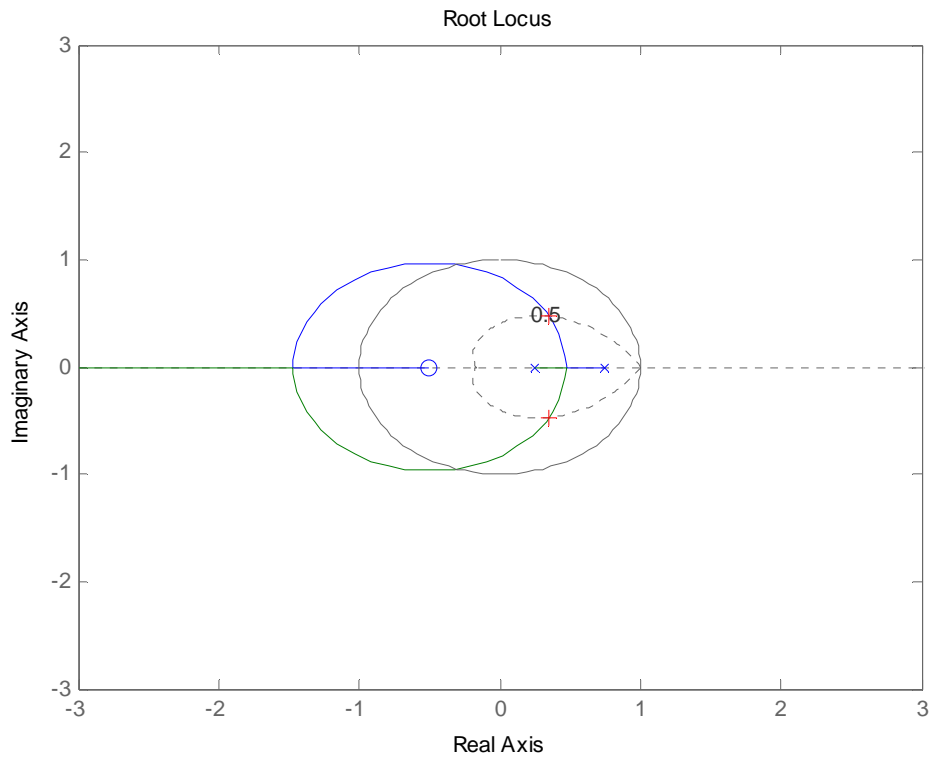

Root Locus Interactive. A trace of  $z=0.5$  was made to guide the user's selection of poles.

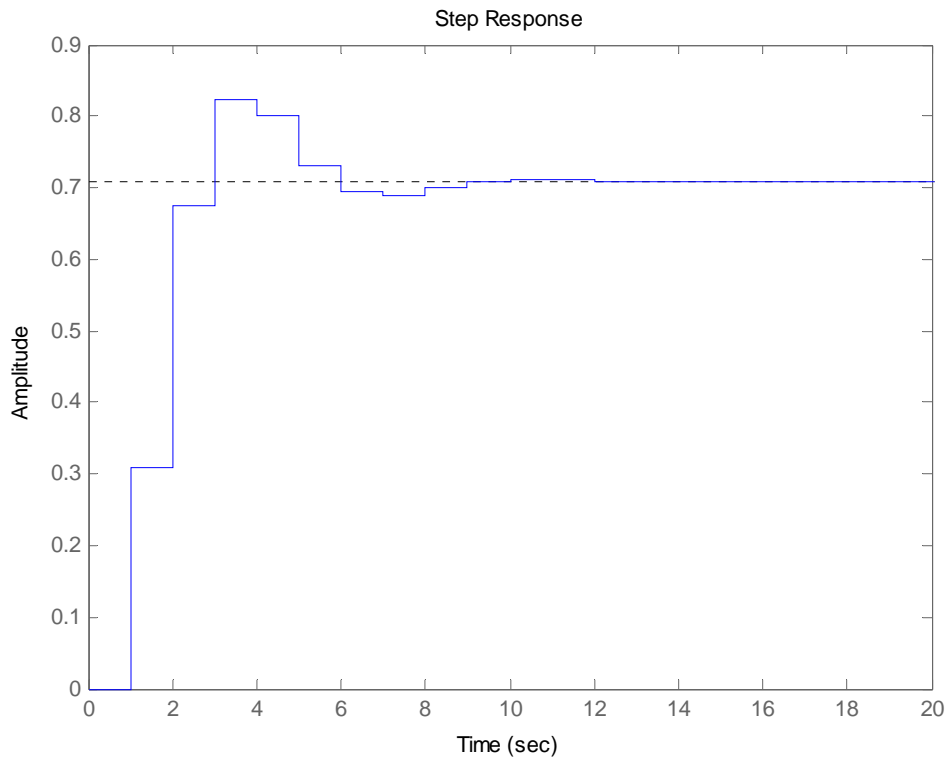

**Step response of the close loop discrete system**

**Block Diagram**

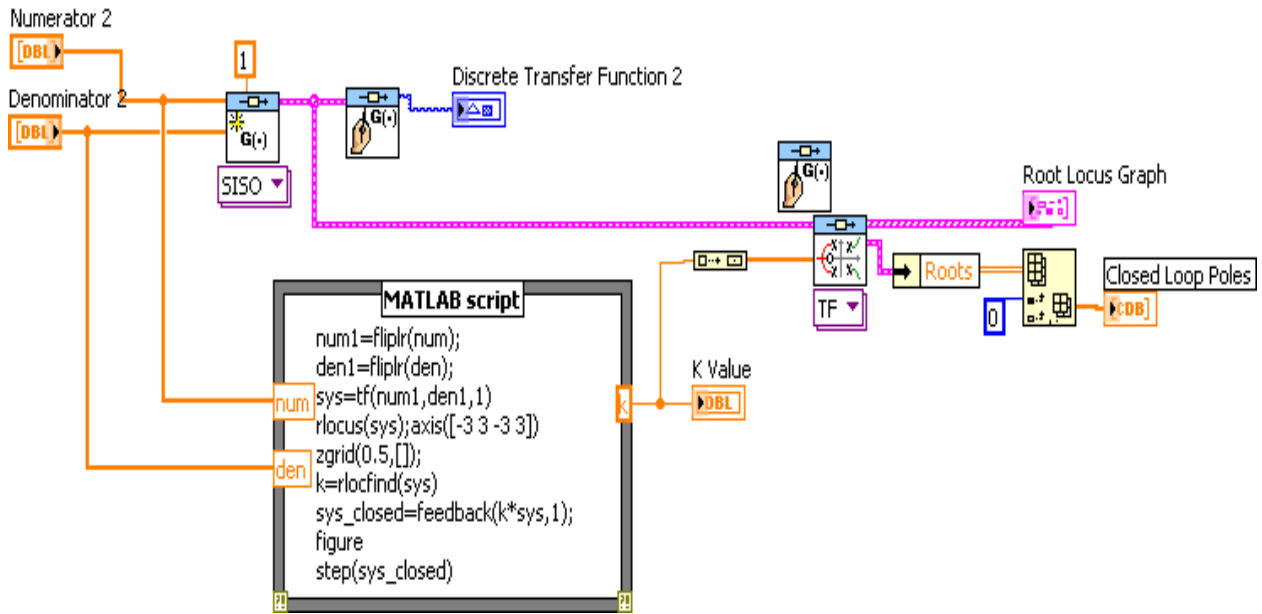

40.

a. From Chapter 9, the plant without the pots and unity gain power amplifier is

$$G_p(s) = \frac{64.88 (s+53.85)}{(s^2 + 8.119s + 376.3) (s^2 + 15.47s + 9283)}$$

The PID controller and notch filter with gain adjusted for replacement of pots (i.e. divided by 100) was

$$G_c(s) = \frac{26.82 (s+24.1) (s+0.1) (s^2 + 16.s + 9200)}{s (s+60)^2}$$

Thus,  $G_e(s) = G_p(s)G_c(s)$  is

$$G_{et}(s) = \frac{1740.0816 (s+53.85)(s^2 + 16s + 9200)(s+24.09)(s+0.1)}{s (s^2 + 8.119s + 376.3) (s^2 + 15.47s + 9283)(s+60)^2}$$

A Bode magnitude plot of  $G_c(s)$  shows  $\omega_c = 36.375$  rad/s. Thus, the maximum T should be in the range  $0.15/\omega_c$  to  $0.5/\omega_c$  or  $4.1237e-03$  to  $1.3746e-02$ . Let us select  $T = 0.001$ .

Performing a Tustin transformation on  $G_c(s)$  yields

$$G_c(z) = \frac{5.166e04 z^4 - 2.041e05 z^3 + 3.029e05 z^2 - 2.001e05 z + 4.963e04}{z^4 - 1.883 z^3 - 0.1131 z^2 + 1.883 z - 0.8869}$$

b. Drawing the flowchart

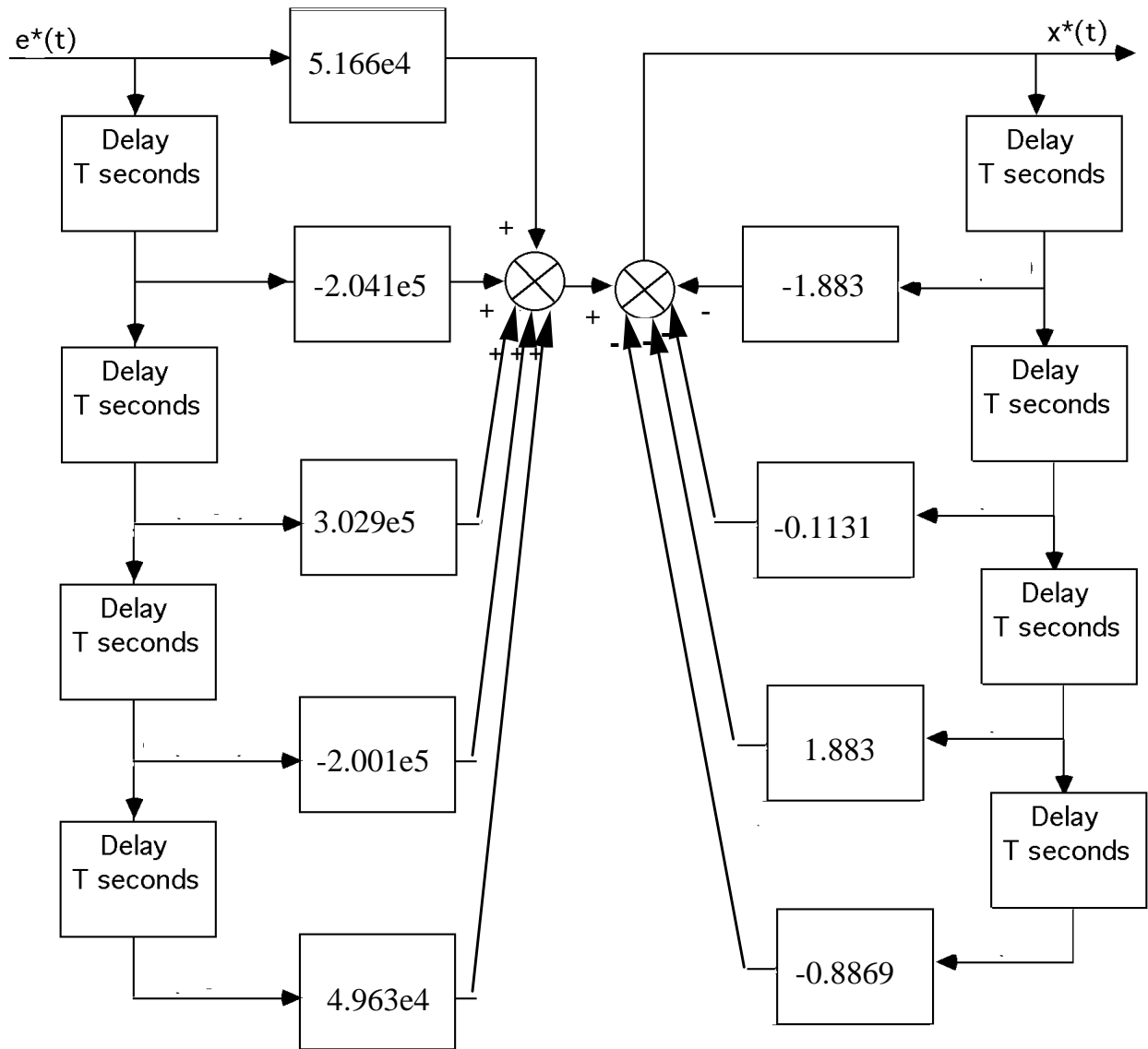

$T = 0.001$

c.

**Program:**

```
syms s
'Compensator from Chapter 9'
T=.001
Gc=26.82*(s^2+16*s+9200)*(s+24.09)*(s+.1)/(s*((s+60)^2));
Gc=vpa(Gc,4);
[numgc,dengc]=numden(Gc);
numgc=sym2poly(numgc);
dengc=sym2poly(dengc);
```

```

Gc=tf(numgc,dengc);
'Gc(s)'
Gczpk=zpk(Gc)
'Gc(z)'
Gcz=c2d(Gc,T,'tustin')
'Gc(z)'
Gczpk=zpk(Gcz)
'Plant from Chapter 9'
Gp=64.88*(s+53.85)/[(s^2+15.47*s+9283)*(s^2+8.119*s+376.3)];
Gp=vpa(Gp,4);
[numgp,dengp]=numden(Gp);
numgp=sym2poly(numgp);
dengp=sym2poly(dengp);
'Gp(s)'
Gp=tf(numgp,dengp)
'Gp(s)'
Gpzpk=zpk(Gp)
'Gp(z)'
Gpz=c2d(Gp,T,'zoh')
'Gez=Gcz*Gpz'
Gez=Gcz*Gpz
Tz=feedback(Gez,1);
t=0:T:1;
step(Tz,t)
pause
t=0:T:50;
step(Tz,t)

```

**Computer response:**

ans =

Compensator from Chapter 9

T =

0.0010

ans =

Gc(s)

Zero/pole/gain:

26.82 (s+24.09) (s+0.1) (s^2 + 16s + 9198)

-----  
s (s+60)^2

ans =

Gc(z)

Transfer function:

5.117e004 z^4 - 2.043e005 z^3 + 3.031e005 z^2 - 2.002e005 z + 4.966e004

-----  
z^4 - 1.883 z^3 - 0.1131 z^2 + 1.883 z - 0.8869

Sampling time: 0.001

ans =

Gc(z)

Zero/pole/gain:  

$$\frac{51699.4442 (z-1) (z-0.9762) (z^2 - 1.975z + 0.9842)}{(z+1) (z-1) (z-0.9417)^2}$$

Sampling time: 0.001

ans =

Plant from Chapter 9

ans =

Gp(s)

Transfer function:

$$\frac{64.88 s + 3494}{s^4 + 23.59 s^3 + 9785 s^2 + 8.119e004 s + 3.493e006}$$

ans =

Gp(s)

Zero/pole/gain:

$$\frac{64.88 (s+53.85)}{(s^2 + 8.119s + 376.3) (s^2 + 15.47s + 9283)}$$

ans =

Gp(z)

Transfer function:

$$\frac{1.089e-008 z^3 + 3.355e-008 z^2 - 3.051e-008 z - 1.048e-008}{z^4 - 3.967 z^3 + 5.911 z^2 - 3.92 z + 0.9767}$$

Sampling time: 0.001

ans =

Gez=Gcz\*Gpz

Transfer function:

$$\frac{0.000563 z^7 - 0.0004901 z^6 - 0.005129 z^5 + 0.01368 z^4 - 0.01328 z^3 + 0.004599 z^2 + 0.0005822 z - 0.0005203}{z^8 - 5.85 z^7 + 13.27 z^6 - 12.72 z^5 - 0.6664 z^4 + 13.25 z^3 - 12.74 z^2 + 5.317 z - 0.8662}$$

Sampling time: 0.001

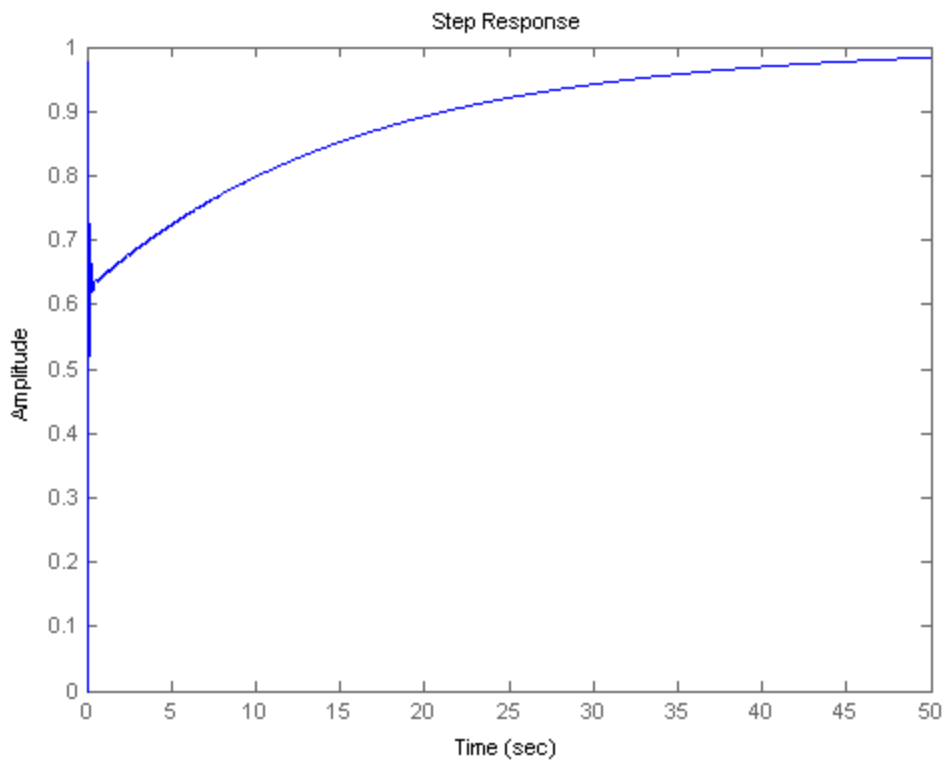
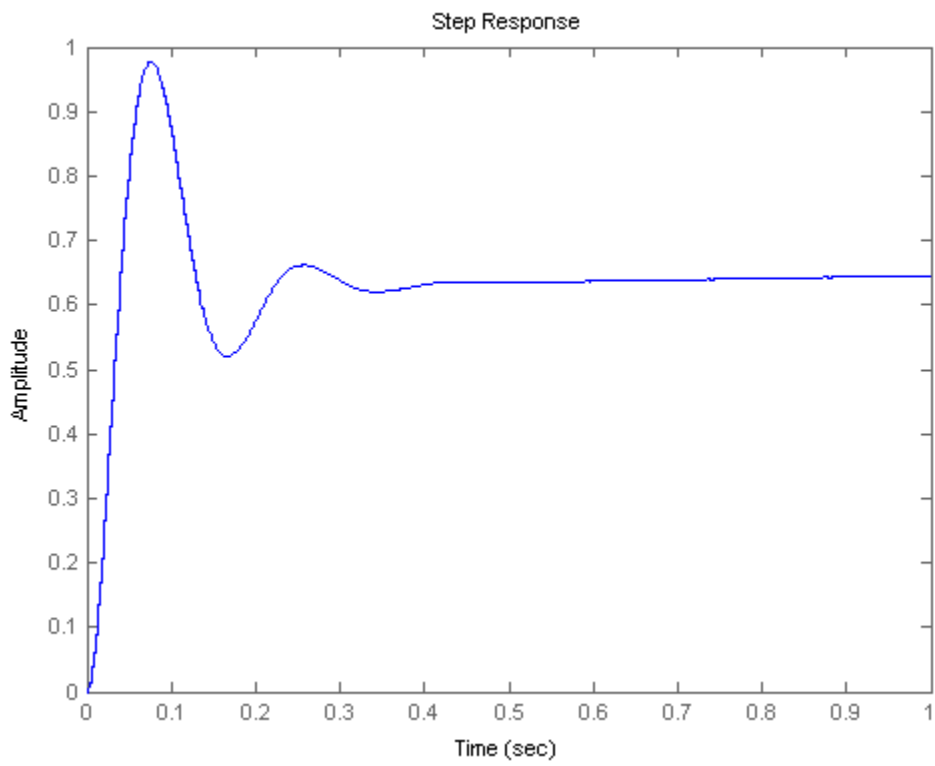



41.

a. A bode plot of the open loop transmission  $G_c(s)P(s)$  shows that the open loop transfer function has a crossover frequency of  $\omega_c = 0.04 \frac{rad}{day}$ . A convenient range for sampling periods

is  $3.75day = \frac{0.15}{\omega_c} < T < \frac{0.5}{\omega_c} = 12.5day$ .  $T=8$  days fall within range.

b. We substitute  $s = \frac{1}{4} \frac{z-1}{z+1}$  into  $G_c(s)$  we get

$$G_c(z) = \frac{-2 \times 10^{-4} (1.145z^2 - 1.71z + 0.8489)}{z^2 - 1.852z + 0.8519}$$

c.

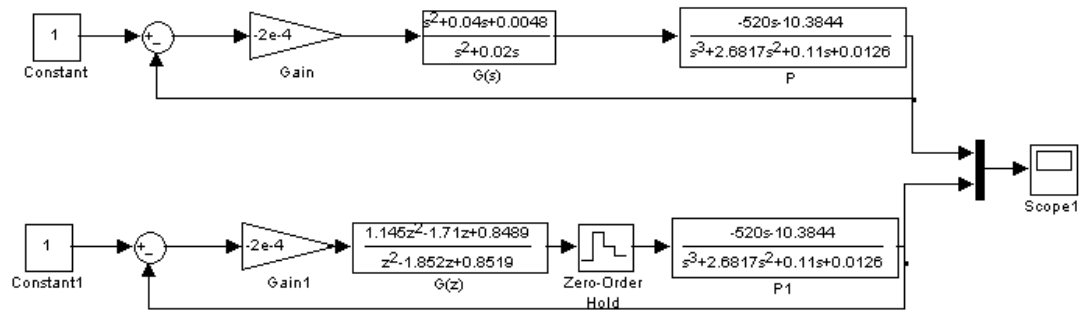

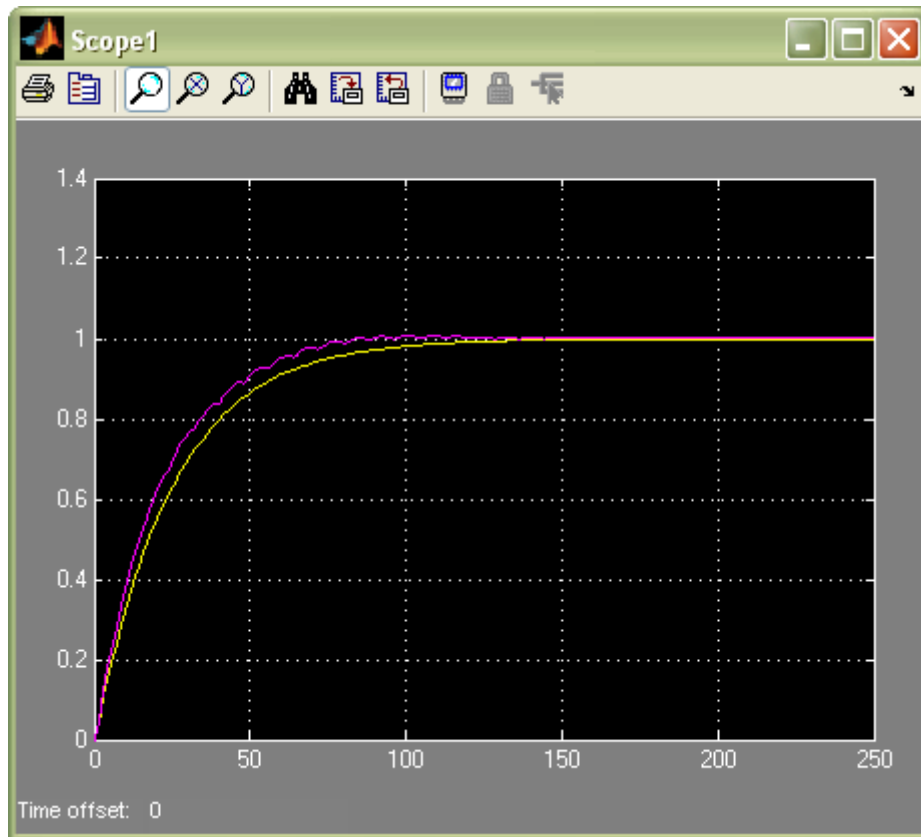

42.

a. The following MATLAB M-file was developed

```

%Digitize G1(s) preceded by a sample and hold
%Input transient response specifications
Po=input('Type %OS ');
K = input('Type Proportional Gain of PI controller ');

numg1 = K*poly([-0.01304 -0.6]);
deng1 = poly([0 -0.01631 -0.5858]);
G1 = tf(numg1,deng1);

for T=5:-.01:0;
    Gz=c2d(G1,T,'zoh');

```

```

Tz=feedback(Gz,1);

r=pole(Tz);

rm=max(abs(r));

if rm<=1;

break;

end;

end;

'G1(s)';

G1s=tf(numg1,deng1);

'G(z)';

Gz=c2d(G1s,0.75*T,'zoh');

%Determine damping ratio

z=(-log(Po/100))/(sqrt(pi^2+log(Po/100)^2));

%Plot root locus

rlocus(Gz)

zgrid(z,0)

title('Root Locus')

[K,p]=rlocfind(Gz); %Allows input by selecting point on graphic

pause

'T(z)';

Tz=feedback(K*Gz,1);

step(Tz)

```

- b.** As the M-file developed in (a) was run and the values of the desired percent overshoot,  $\%O.S. = 0$ , and PI speed controller's proportional gain,  $K = 61$  were entered, the root locus, shown below, was obtained.
- c.** A point was selected on the root locus such that is inside the unit circle. That point is:  $0.9837 + 0.0000i$
- d.** The sampled data transfer functions,  $G_z$  and  $T_z$ , obtained at a Sampling time,  $T = 0.0225 = 0.75 \cdot 0.03$  are:

$$G_z = \frac{1.373 z^2 - 2.727 z + 1.354}{z^3 - 2.987 z^2 + 2.973 z - 0.9865}$$

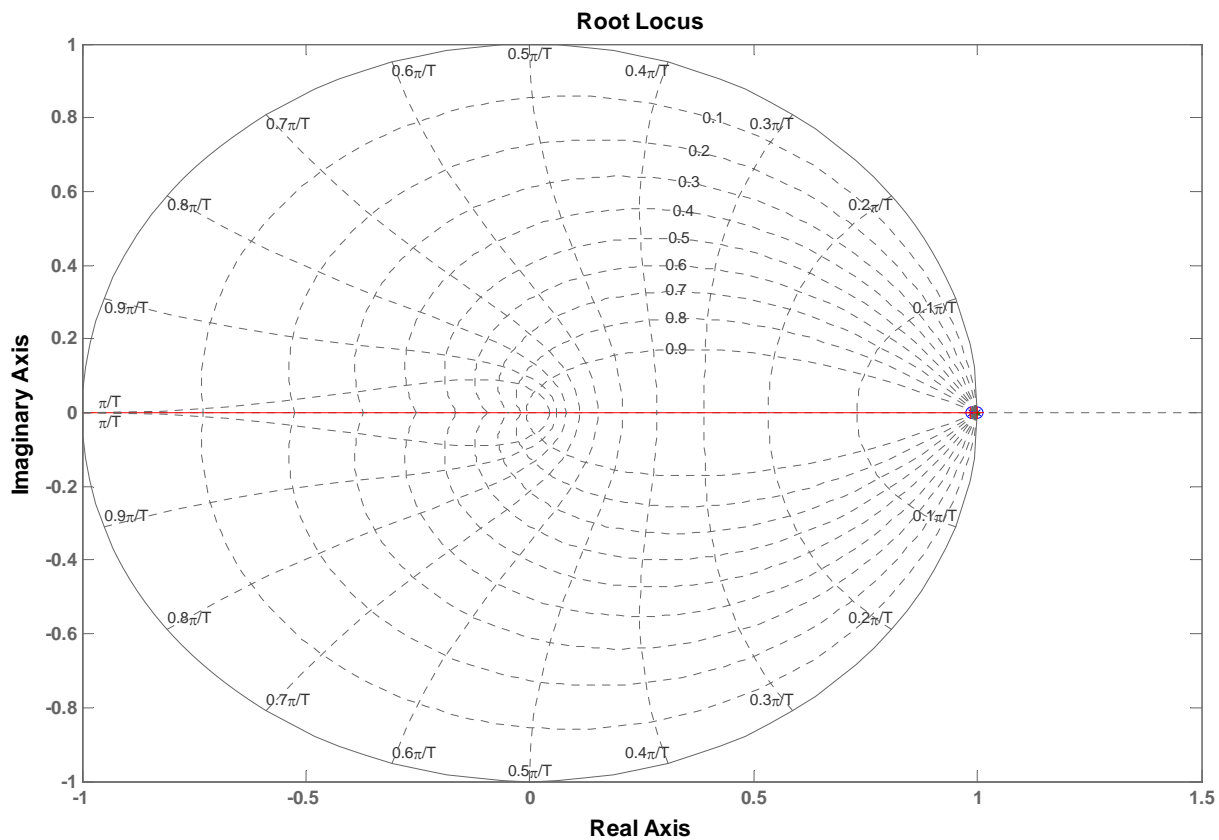

and

$$T_z = \frac{0.018 z^2 - 0.03575 z + 0.01775}{z^3 - 2.969 z^2 + 2.973 z - 0.9688}$$

The poles,  $r$ , of the closed-loop transfer function,  $T_z$ , are:

$$-0.8300, 0.9996, 0.9822$$

- e. The step response of this digital system,  $T_z$ , is shown below with the main transient response characteristics (the final value, rise time, and settling time) displayed on the graph. These are:

$$\text{Final Value} = c(\infty) = 1 \text{ p. u.};$$

$$\text{Rise Time} = T_r = 2.68 \text{ seconds};$$

$$\text{Settling Time} = T_s = 4.82 \text{ seconds.}$$

