

Solutions to Skill-Assessment Exercises

CHAPTER 2

2.1

The Laplace transform of t is $\frac{1}{s^2}$ using Table 2.1, Item 3. Using Table 2.2, Item 4,

$$F(s) = \frac{1}{(s+5)^2}.$$

2.2

Expanding $F(s)$ by partial fractions yields:

$$F(s) = \frac{A}{s} + \frac{B}{s+2} + \frac{C}{(s+3)^2} + \frac{D}{s+3}$$

where,

$$A = \frac{10}{(s+2)(s+3)^2} \Big|_{s \rightarrow 0} = \frac{5}{9} \quad B = \frac{10}{s(s+3)^2} \Big|_{s \rightarrow -2} = -5$$

$$C = \frac{10}{s(s+2)} \Big|_{s \rightarrow -3} = \frac{10}{3}, \text{ and } D = (s+3)^2 \frac{dF(s)}{ds} \Big|_{s \rightarrow -3} = \frac{40}{9}$$

Taking the inverse Laplace transform yields,

$$f(t) = \frac{5}{9} - 5e^{-2t} + \frac{10}{3}te^{-3t} + \frac{40}{9}e^{-3t}$$

2.3

Taking the Laplace transform of the differential equation assuming zero initial conditions yields:

$$s^3C(s) + 3s^2C(s) + 7sC(s) + 5C(s) = s^2R(s) + 4sR(s) + 3R(s)$$

Collecting terms,

$$(s^3 + 3s^2 + 7s + 5)C(s) = (s^2 + 4s + 3)R(s)$$

Thus,

$$\frac{C(s)}{R(s)} = \frac{s^2 + 4s + 3}{s^3 + 3s^2 + 7s + 5}$$

2.4

$$G(s) = \frac{C(s)}{R(s)} = \frac{2s + 1}{s^2 + 6s + 2}$$

Cross multiplying yields,

$$\frac{d^2c}{dt^2} + 6\frac{dc}{dt} + 2c = 2\frac{dr}{dt} + r$$

2.5

$$C(s) = R(s)G(s) = \frac{1}{s^2} * \frac{s}{(s+4)(s+8)} = \frac{1}{s(s+4)(s+8)} = \frac{A}{s} + \frac{B}{(s+4)} + \frac{C}{(s+8)}$$

where

$$A = \frac{1}{(s+4)(s+8)} \Big|_{s \rightarrow 0} = \frac{1}{32} \quad B = \frac{1}{s(s+8)} \Big|_{s \rightarrow -4} = -\frac{1}{16}, \quad \text{and } C = \frac{1}{s(s+4)} \Big|_{s \rightarrow -8} = \frac{1}{32}$$

Thus,

$$c(t) = \frac{1}{32} - \frac{1}{16}e^{-4t} + \frac{1}{32}e^{-8t}$$

2.6

Mesh Analysis

Transforming the network yields,

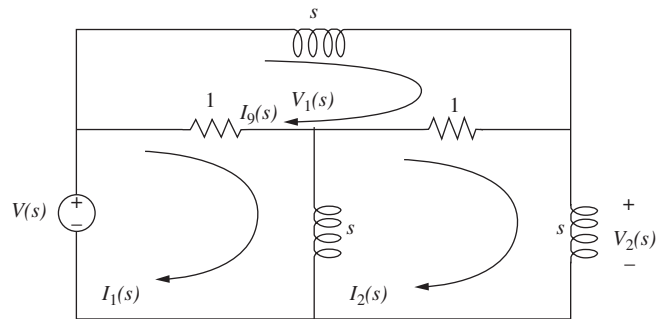

Now, writing the mesh equations,

$$\begin{aligned} (s+1)I_1(s) - sI_2(s) - I_3(s) &= V(s) \\ -sI_1(s) + (2s+1)I_2(s) - I_3(s) &= 0 \\ -I_1(s) - I_2(s) + (s+2)I_3(s) &= 0 \end{aligned}$$

Solving the mesh equations for $I_2(s)$,

$$I_2(s) = \frac{\begin{vmatrix} (s+1) & V(s) & -1 \\ -s & 0 & -1 \\ -1 & 0 & (s+2) \end{vmatrix}}{\begin{vmatrix} (s+1) & -s & -1 \\ -s & (2s+1) & -1 \\ -1 & -1 & (s+2) \end{vmatrix}} = \frac{(s^2 + 2s + 1)V(s)}{s(s^2 + 5s + 2)}$$

But, $V_L(s) = sI_2(s)$

Hence,

$$V_L(s) = \frac{(s^2 + 2s + 1)V(s)}{(s^2 + 5s + 2)}$$

or

$$\frac{V_L(s)}{V(s)} = \frac{s^2 + 2s + 1}{s^2 + 5s + 2}$$

Nodal Analysis

Writing the nodal equations,

$$\begin{aligned} \left(\frac{1}{s} + 2\right)V_1(s) - V_L(s) &= V(s) \\ -V_1(s) + \left(\frac{2}{s} + 1\right)V_L(s) &= \frac{1}{s}V(s) \end{aligned}$$

Solving for $V_L(s)$,

$$V_L(s) = \frac{\begin{vmatrix} \left(\frac{1}{s} + 2\right) & V(s) \\ -1 & \frac{1}{s}V(s) \end{vmatrix}}{\begin{vmatrix} \left(\frac{1}{s} + 2\right) & -1 \\ -1 & \left(\frac{2}{s} + 1\right) \end{vmatrix}} = \frac{(s^2 + 2s + 1)V(s)}{(s^2 + 5s + 2)}$$

or

$$\frac{V_L(s)}{V(s)} = \frac{s^2 + 2s + 1}{s^2 + 5s + 2}$$

2.7

Inverting

$$G(s) = -\frac{Z_2(s)}{Z_1(s)} = \frac{-100000}{(10^5/s)} = -s$$

Noninverting

$$G(s) = \frac{[Z_1(s) + Z(s)]}{Z_1(s)} = \frac{\left(\frac{10^5}{s} + 10^5\right)}{\left(\frac{10^5}{s}\right)} = s + 1$$

2.8

Writing the equations of motion,

$$\begin{aligned} (s^2 + 3s + 1)X_1(s) - (3s + 1)X_2(s) &= F(s) \\ -(3s + 1)X_1(s) + (s^2 + 4s + 1)X_2(s) &= 0 \end{aligned}$$

Solving for $X_2(s)$,

$$X_2(s) = \frac{\begin{vmatrix} (s^2 + 3s + 1) & F(s) \\ -(3s + 1) & 0 \end{vmatrix}}{\begin{vmatrix} (s^2 + 3s + 1) & -(3s + 1) \\ -(3s + 1) & (s^2 + 4s + 1) \end{vmatrix}} = \frac{(3s + 1)F(s)}{s(s^3 + 7s^2 + 5s + 1)}$$

Hence,

$$\frac{X_2(s)}{F(s)} = \frac{(3s + 1)}{s(s^3 + 7s^2 + 5s + 1)}$$

2.9

Writing the equations of motion,

$$\begin{aligned} (s^2 + s + 1)\theta_1(s) - (s + 1)\theta_2(s) &= T(s) \\ -(s + 1)\theta_1(s) + (2s + 2)\theta_2(s) &= 0 \end{aligned}$$

where $\theta_1(s)$ is the angular displacement of the inertia.

Solving for $\theta_2(s)$,

$$\theta_2(s) = \frac{\begin{vmatrix} (s^2 + s + 1) & T(s) \\ -(s + 1) & 0 \end{vmatrix}}{\begin{vmatrix} (s^2 + s + 1) & -(s + 1) \\ -(s + 1) & (2s + 2) \end{vmatrix}} = \frac{(s + 1)F(s)}{2s^3 + 3s^2 + 2s + 1}$$

From which, after simplification,

$$\theta_2(s) = \frac{1}{2s^2 + s + 1}$$

2.10

Transforming the network to one without gears by reflecting the 4 N-m/rad spring to the left and multiplying by $(25/50)^2$, we obtain,

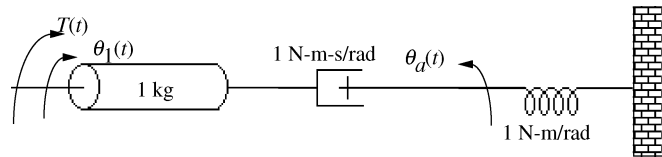

Writing the equations of motion,

$$\begin{aligned} (s^2 + s)\theta_1(s) - s\theta_a(s) &= T(s) \\ -s\theta_1(s) + (s + 1)\theta_a(s) &= 0 \end{aligned}$$

where $\theta_1(s)$ is the angular displacement of the 1-kg inertia.

Solving for $\theta_a(s)$,

$$\theta_a(s) = \frac{\begin{vmatrix} (s^2 + s) & T(s) \\ -s & 0 \end{vmatrix}}{\begin{vmatrix} (s^2 + s) & -s \\ -s & (s + 1) \end{vmatrix}} = \frac{sT(s)}{s^3 + s^2 + s}$$

From which,

$$\frac{\theta_a(s)}{T(s)} = \frac{1}{s^2 + s + 1}$$

But, $\theta_2(s) = \frac{1}{2}\theta_a(s)$.

Thus,

$$\frac{\theta_2(s)}{T(s)} = \frac{1/2}{s^2 + s + 1}$$

2.11

First find the mechanical constants.

$$J_m = J_a + J_L \left(\frac{1}{5} * \frac{1}{4} \right)^2 = 1 + 400 \left(\frac{1}{400} \right) = 2$$

$$D_m = D_a + D_L \left(\frac{1}{5} * \frac{1}{4} \right)^2 = 5 + 800 \left(\frac{1}{400} \right) = 7$$

Now find the electrical constants. From the torque-speed equation, set $\omega_m = 0$ to find stall torque and set $T_m = 0$ to find no-load speed. Hence,

$$T_{stall} = 200$$

$$\omega_{no-load} = 25$$

which,

$$\frac{K_t}{R_a} = \frac{T_{stall}}{E_a} = \frac{200}{100} = 2$$

$$K_b = \frac{E_a}{\omega_{no-load}} = \frac{100}{25} = 4$$

Substituting all values into the motor transfer function,

$$\frac{\theta_m(s)}{E_a(s)} = \frac{\frac{K_T}{R_a J_m}}{s \left(s + \frac{1}{J_m} \right) \left(D_m + \frac{K_T K_b}{R_a} \right)} = \frac{1}{s \left(s + \frac{15}{2} \right)}$$

where $\theta_m(s)$ is the angular displacement of the armature.

Now $\theta_L(s) = \frac{1}{20}\theta_m(s)$. Thus,

$$\frac{\theta_L(s)}{E_a(s)} = \frac{1/20}{s \left(s + \frac{15}{2} \right)}$$

2.12

Letting

$$\theta_1(s) = \omega_1(s)/s$$

$$\theta_2(s) = \omega_2(s)/s$$

in Eqs. 2.127, we obtain

$$\begin{aligned} \left(J_1 s + D_1 + \frac{K}{s} \right) \omega_1(s) - \frac{K}{s} \omega_2(s) &= T(s) \\ -\frac{K}{s} \omega_1(s) + \left(J_2 s + D_2 + \frac{K}{s} \right) \omega_2(s) &= 0 \end{aligned}$$

From these equations we can draw both series and parallel analogs by considering these to be mesh or nodal equations, respectively.

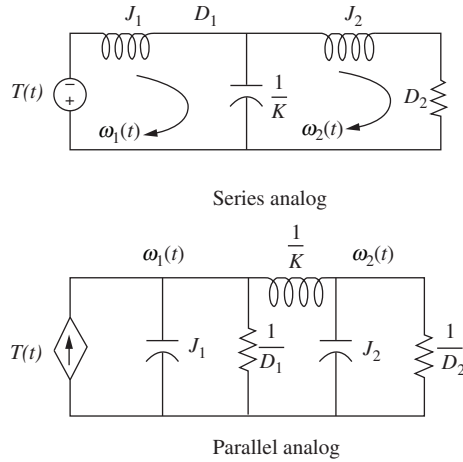

2.13

Writing the nodal equation,

$$C \frac{dv}{dt} + i_r - 2 = i(t)$$

But,

$$C = 1$$

$$v = v_o + \delta v$$

$$i_r = e^{v_r} = e^v = e^{v_o + \delta v}$$

Substituting these relationships into the differential equation,

$$\frac{d(v_o + \delta v)}{dt} + e^{v_o + \delta v} - 2 = i(t) \quad (1)$$

We now linearize e^v .

The general form is

$$f(v) - f(v_o) \approx \left. \frac{df}{dv} \right|_{v_o} \delta v$$

Substituting the function, $f(v) = e^v$, with $v = v_o + \delta v$ yields,

$$e^{v_o + \delta v} - e^{v_o} \approx \left. \frac{de^v}{dv} \right|_{v_o} \delta v$$

Solving for $e^{v_o+\delta v}$,

$$e^{v_o+\delta v} = e^{v_o} + \left. \frac{de^v}{dv} \right|_{v_o} \delta v = e^{v_o} + e^{v_o} \delta v$$

Substituting into Eq. (1)

$$\frac{d\delta v}{dt} + e^{v_o} + e^{v_o} \delta v - 2 = i(t) \quad (2)$$

Setting $i(t) = 0$ and letting the circuit reach steady state, the capacitor acts like an open circuit. Thus, $v_o = v_r$ with $i_r = 2$. But, $i_r = e^{v_r}$ or $v_r = \ln i_r$.

Hence, $v_o = \ln 2 = 0.693$. Substituting this value of v_o into Eq. (2) yields

$$\frac{d\delta v}{dt} + 2\delta v = i(t)$$

Taking the Laplace transform,

$$(s + 2)\delta v(s) = I(s)$$

Solving for the transfer function, we obtain

$$\frac{\delta v(s)}{I(s)} = \frac{1}{s + 2}$$

or

$$\frac{V(s)}{I(s)} = \frac{1}{s + 2} \text{ about equilibrium.}$$

CHAPTER 3

3.1

Identifying appropriate variables on the circuit yields

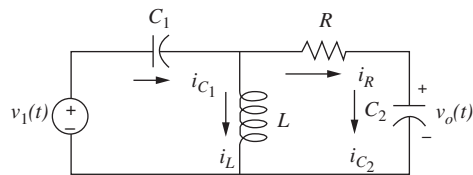

Writing the derivative relations

$$\begin{aligned} C_1 \frac{dv_{C_1}}{dt} &= i_{C_1} \\ L \frac{di_L}{dt} &= v_L \\ C_2 \frac{dv_{C_2}}{dt} &= i_{C_2} \end{aligned} \quad (1)$$

Using Kirchhoff's current and voltage laws,

$$\begin{aligned}i_{C_1} &= i_L + i_R = i_L + \frac{1}{R}(v_L - v_{C_2}) \\v_L &= -v_{C_1} + v_i \\i_{C_2} &= i_R = \frac{1}{R}(v_L - v_{C_2})\end{aligned}$$

Substituting these relationships into Eqs. (1) and simplifying yields the state equations as

$$\begin{aligned}\frac{dv_{C_1}}{dt} &= -\frac{1}{RC_1}v_{C_1} + \frac{1}{C_1}i_L - \frac{1}{RC_1}v_{C_2} + \frac{1}{RC_1}v_i \\ \frac{di_L}{dt} &= -\frac{1}{L}v_{C_1} + \frac{1}{L}v_i \\ \frac{dv_{C_2}}{dt} &= -\frac{1}{RC_2}v_{C_1} - \frac{1}{RC_2}v_{C_2} + \frac{1}{RC_2}v_i\end{aligned}$$

where the output equation is

$$v_o = v_{C_2}$$

Putting the equations in vector-matrix form,

$$\begin{aligned}\dot{\mathbf{x}} &= \begin{bmatrix} -\frac{1}{RC_1} & \frac{1}{C_1} & -\frac{1}{RC_1} \\ -\frac{1}{L} & 0 & 0 \\ -\frac{1}{RC_2} & 0 & -\frac{1}{RC_2} \end{bmatrix} \mathbf{x} + \begin{bmatrix} \frac{1}{RC_1} \\ \frac{1}{L} \\ \frac{1}{RC_2} \end{bmatrix} v_i(t) \\ y &= [0 \quad 0 \quad 1] \mathbf{x}\end{aligned}$$

3.2

Writing the equations of motion

$$\begin{aligned}(s^2 + s + 1)X_1(s) - sX_2(s) &= F(s) \\ -sX_1(s) + (s^2 + s + 1)X_2(s) - X_3(s) &= 0 \\ -X_2(s) + (s^2 + s + 1)X_3(s) &= 0\end{aligned}$$

Taking the inverse Laplace transform and simplifying,

$$\begin{aligned}\ddot{x}_1 &= -\dot{x}_1 - x_1 + \dot{x}_2 + f \\ \ddot{x}_2 &= \dot{x}_1 - \dot{x}_2 - x_2 + x_3 \\ \ddot{x}_3 &= -\dot{x}_3 - x_3 + x_2\end{aligned}$$

Defining state variables, z_i ,

$$z_1 = x_1; z_2 = \dot{x}_1; z_3 = x_2; z_4 = \dot{x}_2; z_5 = x_3; z_6 = \dot{x}_3$$

Writing the state equations using the definition of the state variables and the inverse transform of the differential equation,

$$\begin{aligned}\dot{z}_1 &= z_2 \\ \dot{z}_2 &= \ddot{x}_1 = -\dot{x}_1 - x_1 + \dot{x}_2 + f = -z_2 - z_1 + z_4 + f \\ \dot{z}_3 &= \dot{x}_2 = z_4 \\ \dot{z}_4 &= \ddot{x}_2 = \dot{x}_1 - \dot{x}_2 - x_2 + x_3 = z_2 - z_4 - z_3 + z_5 \\ \dot{z}_5 &= \dot{x}_3 = z_6 \\ \dot{z}_6 &= \ddot{x}_3 = -\dot{x}_3 - x_3 + x_2 = -z_6 - z_5 + z_3\end{aligned}$$

The output is z_5 . Hence, $y = z_5$. In vector-matrix form,

$$\dot{\mathbf{z}} = \begin{bmatrix} 0 & 1 & 0 & 0 & 0 & 0 \\ -1 & -1 & 0 & 1 & 0 & 0 \\ 0 & 0 & 0 & 1 & 0 & 0 \\ 0 & 1 & -1 & -1 & 1 & 0 \\ 0 & 0 & 0 & 0 & 0 & 1 \\ 0 & 0 & 1 & 0 & -1 & -1 \end{bmatrix} \mathbf{z} + \begin{bmatrix} 0 \\ 1 \\ 0 \\ 0 \\ 0 \\ 0 \end{bmatrix} f(t); y = [0 \ 0 \ 0 \ 0 \ 1 \ 0] \mathbf{z}$$

3.3

First derive the state equations for the transfer function without zeros.

$$\frac{X(s)}{R(s)} = \frac{1}{s^2 + 7s + 9}$$

Cross multiplying yields

$$(s^2 + 7s + 9)X(s) = R(s)$$

Taking the inverse Laplace transform assuming zero initial conditions, we get

$$\ddot{x} + 7\dot{x} + 9x = r$$

Defining the state variables as,

$$\begin{aligned}x_1 &= x \\ x_2 &= \dot{x}\end{aligned}$$

Hence,

$$\begin{aligned}\dot{x}_1 &= x_2 \\ \dot{x}_2 &= \ddot{x} = -7\dot{x} - 9x + r = -9x_1 - 7x_2 + r\end{aligned}$$

Using the zeros of the transfer function, we find the output equation to be,

$$c = 2\dot{x} + x = x_1 + 2x_2$$

Putting all equation in vector-matrix form yields,

$$\begin{aligned}\dot{\mathbf{x}} &= \begin{bmatrix} 0 & 1 \\ -9 & -7 \end{bmatrix} \mathbf{x} + \begin{bmatrix} 0 \\ 1 \end{bmatrix} r \\ c &= [1 \ 2] \mathbf{x}\end{aligned}$$

3.4

The state equation is converted to a transfer function using

$$G(s) = \mathbf{C}(s\mathbf{I} - \mathbf{A})^{-1}\mathbf{B} \quad (1)$$

where

$$\mathbf{A} = \begin{bmatrix} -4 & -1.5 \\ 4 & 0 \end{bmatrix}, \mathbf{B} = \begin{bmatrix} 2 \\ 0 \end{bmatrix}, \text{ and } \mathbf{C} = [1.5 \quad 0.625].$$

Evaluating $(s\mathbf{I} - \mathbf{A})$ yields

$$(s\mathbf{I} - \mathbf{A}) = \begin{bmatrix} s + 4 & 1.5 \\ -4 & s \end{bmatrix}$$

Taking the inverse we obtain

$$(s\mathbf{I} - \mathbf{A})^{-1} = \frac{1}{s^2 + 4s + 6} \begin{bmatrix} s & -1.5 \\ 4 & s + 4 \end{bmatrix}$$

Substituting all expressions into Eq. (1) yields

$$G(s) = \frac{3s + 5}{s^2 + 4s + 6}$$

3.5

Writing the differential equation we obtain

$$\frac{d^2x}{dt^2} + 2x^2 = 10 + \delta f(t) \quad (1)$$

Letting $x = x_o + \delta x$ and substituting into Eq. (1) yields

$$\frac{d^2(x_o + \delta x)}{dt^2} + 2(x_o + \delta x)^2 = 10 + \delta f(t) \quad (2)$$

Now, linearize x^2 .

$$(x_o + \delta x)^2 - x_o^2 = \left. \frac{d(x^2)}{dx} \right|_{x_o} \delta x = 2x_o \delta x$$

from which

$$(x_o + \delta x)^2 = x_o^2 + 2x_o \delta x \quad (3)$$

Substituting Eq. (3) into Eq. (1) and performing the indicated differentiation gives us the linearized intermediate differential equation,

$$\frac{d^2 \delta x}{dt^2} + 4x_o \delta x = -2x_o^2 + 10 + \delta f(t) \quad (4)$$

The force of the spring at equilibrium is 10 N. Thus, since $F = 2x^2$, $10 = 2x_o^2$ from which

$$x_o = \sqrt{5}$$

Substituting this value of x_o into Eq. (4) gives us the final linearized differential equation.

$$\frac{d^2 \delta x}{dt^2} + 4\sqrt{5} \delta x = \delta f(t)$$

Selecting the state variables,

$$\begin{aligned} x_1 &= \delta x \\ x_2 &= \dot{\delta x} \end{aligned}$$

Writing the state and output equations

$$\begin{aligned} \dot{x}_1 &= x_2 \\ \dot{x}_2 &= \ddot{\delta x} = -4\sqrt{5}x_1 + \delta f(t) \\ y &= x_1 \end{aligned}$$

Converting to vector-matrix form yields the final result as

$$\begin{aligned} \dot{\mathbf{x}} &= \begin{bmatrix} 0 & 1 \\ -4\sqrt{5} & 0 \end{bmatrix} \mathbf{x} + \begin{bmatrix} 0 \\ 1 \end{bmatrix} \delta f(t) \\ y &= [1 \quad 0] \mathbf{x} \end{aligned}$$

CHAPTER 4

4.1

For a step input

$$C(s) = \frac{10(s+4)(s+6)}{s(s+1)(s+7)(s+8)(s+10)} = \frac{A}{s} + \frac{B}{s+1} + \frac{C}{s+7} + \frac{D}{s+8} + \frac{E}{s+10}$$

Taking the inverse Laplace transform,

$$c(t) = A + Be^{-t} + Ce^{-7t} + De^{-8t} + Ee^{-10t}$$

4.2

Since $a = 50$, $T_c = \frac{1}{a} = \frac{1}{50} = 0.02\text{s}$; $T_s = \frac{4}{a} = \frac{4}{50} = 0.08\text{ s}$; and

$$T_r = \frac{2.2}{a} = \frac{2.2}{50} = 0.044\text{ s}.$$

4.3

- Since poles are at $-6 \pm j19.08$, $c(t) = A + Be^{-6t} \cos(19.08t + \phi)$.
- Since poles are at -78.54 and -11.46 , $c(t) = A + Be^{-78.54t} + Ce^{-11.4t}$.
- Since poles are double on the real axis at -15 $c(t) = A + Be^{-15t} + Cte^{-15t}$.
- Since poles are at $\pm j25$, $c(t) = A + B \cos(25t + \phi)$.

4.4

- $\omega_n = \sqrt{400} = 20$ and $2\zeta\omega_n = 12$; $\therefore \zeta = 0.3$ and system is underdamped.
- $\omega_n = \sqrt{900} = 30$ and $2\zeta\omega_n = 90$; $\therefore \zeta = 1.5$ and system is overdamped.
- $\omega_n = \sqrt{225} = 15$ and $2\zeta\omega_n = 30$; $\therefore \zeta = 1$ and system is critically damped.
- $\omega_n = \sqrt{625} = 25$ and $2\zeta\omega_n = 0$; $\therefore \zeta = 0$ and system is undamped.

4.5

$$\omega_n = \sqrt{361} = 19 \text{ and } 2\zeta\omega_n = 16; \quad \therefore \zeta = 0.421.$$

$$\text{Now, } T_s = \frac{4}{\zeta\omega_n} = 0.5 \text{ s and } T_p = \frac{\pi}{\omega_n\sqrt{1-\zeta^2}} = 0.182 \text{ s.}$$

From Figure 4.16, $\omega_n T_r = 1.4998$. Therefore, $T_r = 0.079$ s.

$$\text{Finally, } \%os = e^{\frac{-\zeta\pi}{\sqrt{1-\zeta^2}}} * 100 = 23.3\%$$

4.6

- The second-order approximation is valid, since the dominant poles have a real part of -2 and the higher-order pole is at -15 , i.e. more than five-times further.
- The second-order approximation is not valid, since the dominant poles have a real part of -1 and the higher-order pole is at -4 , i.e. not more than five-times further.

4.7

- Expanding $G(s)$ by partial fractions yields $G(s) = \frac{1}{s} + \frac{0.8942}{s+20} - \frac{1.5918}{s+10} - \frac{0.3023}{s+6.5}$.
But -0.3023 is not an order of magnitude less than residues of second-order terms (term 2 and 3). Therefore, a second-order approximation is not valid.
- Expanding $G(s)$ by partial fractions yields $G(s) = \frac{1}{s} + \frac{0.9782}{s+20} - \frac{1.9078}{s+10} - \frac{0.0704}{s+6.5}$.
But 0.0704 is an order of magnitude less than residues of second-order terms (term 2 and 3). Therefore, a second-order approximation is valid.

4.8

See Figure 4.31 in the textbook for the Simulink block diagram and the output responses.

4.9

$$\text{a. Since } s\mathbf{I} - \mathbf{A} = \begin{bmatrix} s & -2 \\ 3 & s+5 \end{bmatrix}, (s\mathbf{I} - \mathbf{A})^{-1} = \frac{1}{s^2 + 5s + 6} \begin{bmatrix} s+5 & 2 \\ -3 & s \end{bmatrix}. \quad \text{Also,}$$

$$\mathbf{B}\mathbf{U}(s) = \begin{bmatrix} 0 \\ 1/(s+1) \end{bmatrix}.$$

$$\text{The state vector is } \mathbf{X}(s) = (s\mathbf{I} - \mathbf{A})^{-1}[\mathbf{x}(0) + \mathbf{B}\mathbf{U}(s)] = \frac{1}{(s+1)(s+2)(s+3)} \times$$

$$\begin{bmatrix} 2(s^2 + 7s + 7) \\ s^2 - 4s - 6 \end{bmatrix}. \text{ The output is } Y(s) = [1 \quad 3]\mathbf{X}(s) = \frac{5s^2 + 2s - 4}{(s+1)(s+2)(s+3)} =$$

$$-\frac{0.5}{s+1} - \frac{12}{s+2} + \frac{17.5}{s+3}. \text{ Taking the inverse Laplace transform yields } y(t) =$$

$$-0.5e^{-t} - 12e^{-2t} + 17.5e^{-3t}.$$

- The eigenvalues are given by the roots of $|s\mathbf{I} - \mathbf{A}| = s^2 + 5s + 6$, or -2 and -3 .

4.10

$$\text{a. Since } (s\mathbf{I} - \mathbf{A}) = \begin{bmatrix} s & -2 \\ 2 & s+5 \end{bmatrix}, (s\mathbf{I} - \mathbf{A})^{-1} = \frac{1}{s^2 + 5s + 4} \begin{bmatrix} s+5 & 2 \\ -2 & s \end{bmatrix}. \text{ Taking the}$$

Laplace transform of each term, the state transition matrix is given by

$$\Phi(t) = \begin{bmatrix} \frac{4}{3}e^{-t} - \frac{1}{3}e^{-4t} & \frac{2}{3}e^{-t} - \frac{2}{3}e^{-4t} \\ -\frac{2}{3}e^{-t} + \frac{2}{3}e^{-4t} & -\frac{1}{3}e^{-t} + \frac{4}{3}e^{-4t} \end{bmatrix}.$$

b. Since $\Phi(t - \tau) = \begin{bmatrix} \frac{4}{3}e^{-(t-\tau)} - \frac{1}{3}e^{-4(t-\tau)} & \frac{2}{3}e^{-(t-\tau)} - \frac{2}{3}e^{-4(t-\tau)} \\ -\frac{2}{3}e^{-(t-\tau)} + \frac{2}{3}e^{-4(t-\tau)} & -\frac{1}{3}e^{-(t-\tau)} + \frac{4}{3}e^{-4(t-\tau)} \end{bmatrix}$ and

$$\mathbf{B}\mathbf{u}(\tau) = \begin{bmatrix} 0 \\ e^{-2\tau} \end{bmatrix}, \Phi(t - \tau)\mathbf{B}\mathbf{u}(\tau) = \begin{bmatrix} \frac{2}{3}e^{-\tau}e^{-t} - \frac{2}{3}e^{2\tau}e^{-4t} \\ -\frac{1}{3}e^{-\tau}e^{-t} + \frac{4}{3}e^{2\tau}e^{-4t} \end{bmatrix}.$$

Thus, $\mathbf{x}(t) = \Phi(t)\mathbf{x}(0) + \int_0^t \Phi(t - \tau)$

$$\mathbf{B}\mathbf{U}(\tau)d\tau = \begin{bmatrix} \frac{10}{3}e^{-t} - e^{-2t} - \frac{4}{3}e^{-4t} \\ -\frac{5}{3}e^{-t} + e^{-2t} + \frac{8}{3}e^{-4t} \end{bmatrix}$$

c. $y(t) = [2 \ 1]\mathbf{x} = 5e^{-t} - e^{-2t}$

CHAPTER 5

5.1

Combine the parallel blocks in the forward path. Then, push $\frac{1}{s}$ to the left past the pickoff point.

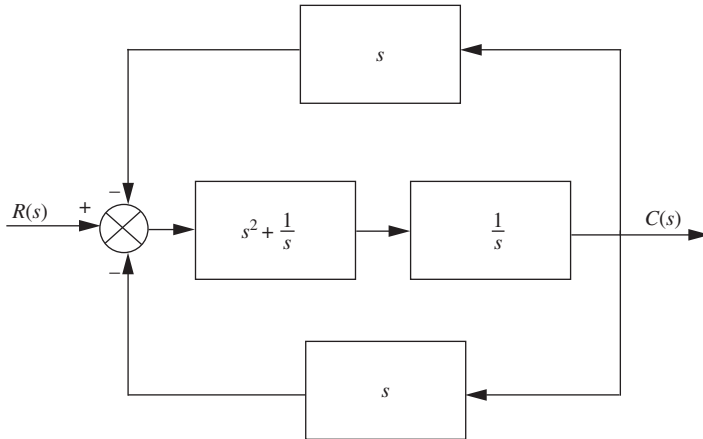

Combine the parallel feedback paths and get $2s$. Then, apply the feedback formula, simplify, and get, $T(s) = \frac{s^3 + 1}{2s^4 + s^2 + 2s}$.

5.2

Find the closed-loop transfer function, $T(s) = \frac{G(s)}{1 + G(s)H(s)} = \frac{16}{s^2 + as + 16}$, where and $G(s) = \frac{16}{s(s+a)}$ and $H(s) = 1$. Thus, $\omega_n = 4$ and $2\zeta\omega_n = a$, from which $\zeta = \frac{a}{8}$.

But, for 5% overshoot, $\zeta = \frac{-\ln\left(\frac{\%}{100}\right)}{\sqrt{\pi^2 + \ln^2\left(\frac{\%}{100}\right)}} = 0.69$. Since, $\zeta = \frac{a}{8}$, $a = 5.52$.

5.3

Label nodes.

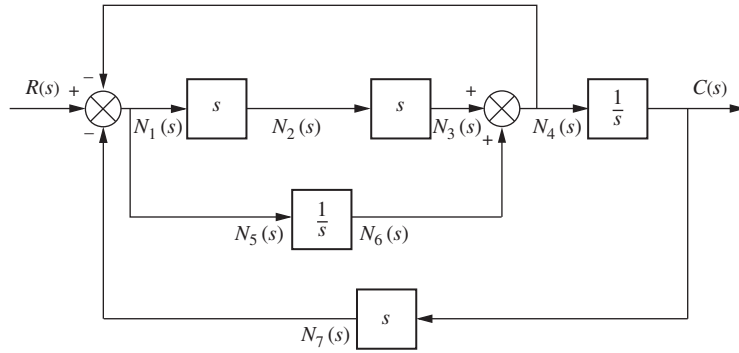

Draw nodes.

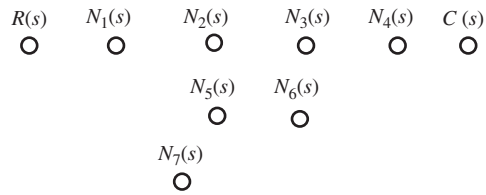

Connect nodes and label subsystems.

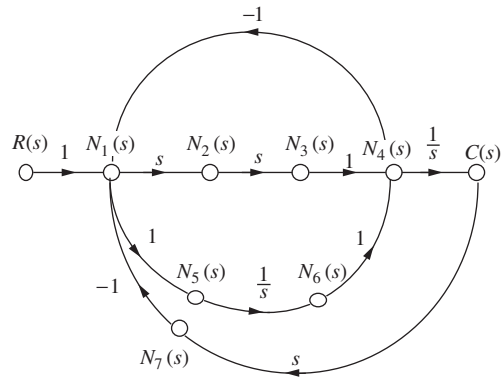

Eliminate unnecessary nodes.

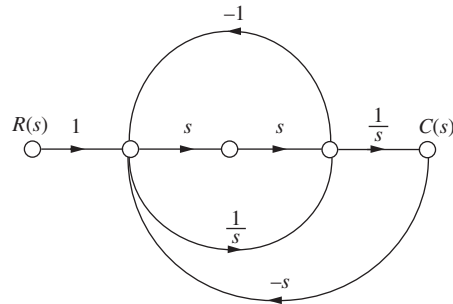

5.4

Forward-path gains are $G_1G_2G_3$ and G_1G_3 .

Loop gains are $-G_1G_2H_1$, $-G_2H_2$, and $-G_3H_3$.

Nontouching loops are $[-G_1G_2H_1][-G_3H_3] = G_1G_2G_3H_1H_3$ and $[-G_2H_2][-G_3H_3] = G_2G_3H_2H_3$.

Also, $\Delta = 1 + G_1G_2H_1 + G_2H_2 + G_3H_3 + G_1G_2G_3H_1H_3 + G_2G_3H_2H_3$.

Finally, $\Delta_1 = 1$ and $\Delta_2 = 1$.

Substituting these values into $T(s) = \frac{C(s)}{R(s)} = \frac{\sum_k T_k \Delta_k}{\Delta}$ yields

$$T(s) = \frac{G_1(s)G_3(s)[1 + G_2(s)]}{[1 + G_2(s)H_2(s) + G_1(s)G_2(s)H_1(s)][1 + G_3(s)H_3(s)]}$$

5.5

The state equations are,

$$\dot{x}_1 = -2x_1 + x_2$$

$$\dot{x}_2 = -3x_2 + x_3$$

$$\dot{x}_3 = -3x_1 - 4x_2 - 5x_3 + r$$

$$y = x_2$$

Drawing the signal-flow diagram from the state equations yields

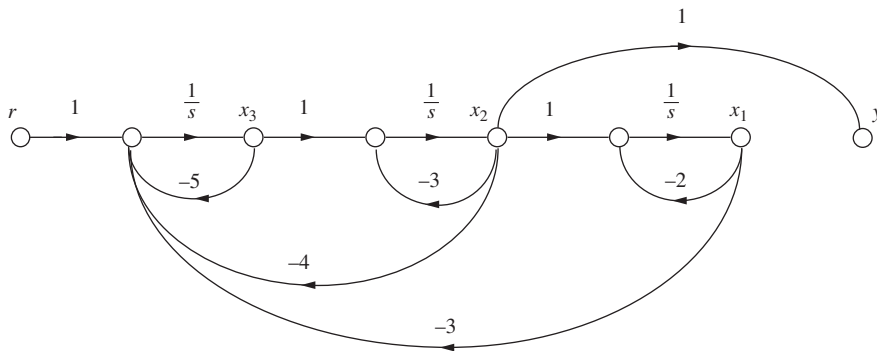

5.6

From $G(s) = \frac{100(s+5)}{s^2+5s+6}$ we draw the signal-flow graph in controller canonical form and add the feedback.

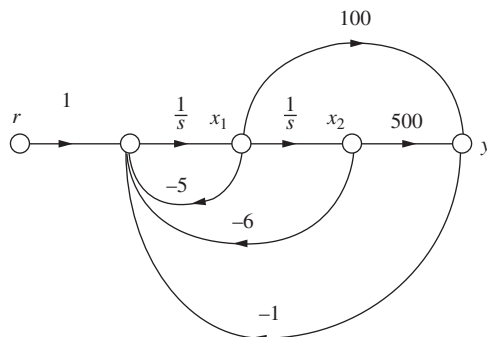

Writing the state equations from the signal-flow diagram, we obtain

$$\begin{aligned}\mathbf{x} &= \begin{bmatrix} -105 & -506 \\ 1 & 0 \end{bmatrix} \mathbf{x} + \begin{bmatrix} 1 \\ 0 \end{bmatrix} r \\ y &= [100 \quad 500] \mathbf{x}\end{aligned}$$

5.7

From the transformation equations,

$$\mathbf{P}^{-1} = \begin{bmatrix} 3 & -2 \\ 1 & -4 \end{bmatrix}$$

Taking the inverse,

$$\mathbf{P} = \begin{bmatrix} 0.4 & -0.2 \\ 0.1 & -0.3 \end{bmatrix}$$

Now,

$$\mathbf{P}^{-1} \mathbf{A} \mathbf{P} = \begin{bmatrix} 3 & -2 \\ 1 & -4 \end{bmatrix} \begin{bmatrix} 1 & 3 \\ -4 & -6 \end{bmatrix} \begin{bmatrix} 0.4 & -0.2 \\ 0.1 & -0.3 \end{bmatrix} = \begin{bmatrix} 6.5 & -8.5 \\ 9.5 & -11.5 \end{bmatrix}$$

$$\mathbf{P}^{-1} \mathbf{B} = \begin{bmatrix} 3 & -2 \\ 1 & -4 \end{bmatrix} \begin{bmatrix} 1 \\ 3 \end{bmatrix} = \begin{bmatrix} -3 \\ -11 \end{bmatrix}$$

$$\mathbf{C} \mathbf{P} = [1 \quad 4] \begin{bmatrix} 0.4 & -0.2 \\ 0.1 & -0.3 \end{bmatrix} = [0.8 \quad -1.4]$$

Therefore,

$$\begin{aligned}\dot{\mathbf{z}} &= \begin{bmatrix} 6.5 & -8.5 \\ 9.5 & -11.5 \end{bmatrix} \mathbf{z} + \begin{bmatrix} -3 \\ -11 \end{bmatrix} u \\ y &= [0.8 \quad -1.4] \mathbf{z}\end{aligned}$$

5.8

First find the eigenvalues.

$$|\lambda \mathbf{I} - \mathbf{A}| = \left| \begin{bmatrix} \lambda & 0 \\ 0 & \lambda \end{bmatrix} - \begin{bmatrix} 1 & 3 \\ -4 & -6 \end{bmatrix} \right| = \begin{vmatrix} \lambda - 1 & -3 \\ 4 & \lambda + 6 \end{vmatrix} = \lambda^2 + 5\lambda + 6$$

From which the eigenvalues are -2 and -3 .

Now use $\mathbf{A} \mathbf{x}_i = \lambda \mathbf{x}_i$ for each eigenvalue, λ .

Thus,

$$\begin{bmatrix} 1 & 3 \\ -4 & -6 \end{bmatrix} \begin{bmatrix} x_1 \\ x_2 \end{bmatrix} = \lambda \begin{bmatrix} x_1 \\ x_2 \end{bmatrix}$$

For $\lambda = -2$,

$$\begin{aligned}3x_1 + 3x_2 &= 0 \\ -4x_1 - 4x_2 &= 0\end{aligned}$$

Thus $x_1 = -x_2$

For $\lambda = -3$

$$\begin{aligned} 4x_1 + 3x_2 &= 0 \\ -4x_1 - 3x_2 &= 0 \end{aligned}$$

Thus $x_1 = -x_2$ and $x_1 = -0.75x_2$; from which we let

$$\mathbf{P} = \begin{bmatrix} 0.707 & -0.6 \\ -0.707 & 0.8 \end{bmatrix}$$

Taking the inverse yields

$$\mathbf{P}^{-1} = \begin{bmatrix} 5.6577 & 4.2433 \\ 5 & 5 \end{bmatrix}$$

Hence,

$$\mathbf{D} = \mathbf{P}^{-1}\mathbf{A}\mathbf{P} = \begin{bmatrix} 5.6577 & 4.2433 \\ 5 & 5 \end{bmatrix} \begin{bmatrix} 1 & 3 \\ -4 & -6 \end{bmatrix} \begin{bmatrix} 0.707 & -0.6 \\ -0.707 & 0.8 \end{bmatrix} = \begin{bmatrix} -2 & 0 \\ 0 & -3 \end{bmatrix}$$

$$\mathbf{P}^{-1}\mathbf{B} = \begin{bmatrix} 5.6577 & 4.2433 \\ 5 & 5 \end{bmatrix} \begin{bmatrix} 1 \\ 3 \end{bmatrix} = \begin{bmatrix} 18.39 \\ 20 \end{bmatrix}$$

$$\mathbf{C}\mathbf{P} = [1 \quad 4] \begin{bmatrix} 0.707 & -0.6 \\ -0.707 & 0.8 \end{bmatrix} = [-2.121 \quad 2.6]$$

Finally,

$$\begin{aligned} \dot{\mathbf{z}} &= \begin{bmatrix} -2 & 0 \\ 0 & -3 \end{bmatrix} \mathbf{z} + \begin{bmatrix} 18.39 \\ 20 \end{bmatrix} u \\ \mathbf{y} &= [-2.121 \quad 2.6] \mathbf{z} \end{aligned}$$

CHAPTER 6

6.1

Make a Routh table.

s^7	3	6	7	2
s^6	9	4	8	6
s^5	4.666666667	4.333333333	0	0
s^4	-4.35714286	8	6	0
s^3	12.90163934	6.426229508	0	0
s^2	10.17026684	6	0	0
s^1	-1.18515742	0	0	0
s^0	6	0	0	0

Since there are four sign changes and no complete row of zeros, there are four right half-plane poles and three left half-plane poles.

6.2

Make a Routh table. We encounter a row of zeros on the s^3 row. The even polynomial is contained in the previous row as $-6s^4 + 0s^2 + 6$. Taking the derivative yields

$-24s^3 + 0s$. Replacing the row of zeros with the coefficients of the derivative yields the s^3 row. We also encounter a zero in the first column at the s^2 row. We replace the zero with ε and continue the table. The final result is shown now as

s^6	1	-6	-1	6	
s^5	1	0	-1	0	
s^4	6	0	6	0	
s^3	-24	0	0	0	ROZ
s^2	ε	6	0	0	
s^1	$144/\varepsilon$	0	0	0	
s^0	6	0	0	0	

There is one sign change below the even polynomial. Thus the even polynomial (4th order) has one right half-plane pole, one left half-plane pole, and 2 imaginary axis poles. From the top of the table down to the even polynomial yields one sign change. Thus, the rest of the polynomial has one right half-plane root, and one left half-plane root. The total for the system is two right half-plane poles, two left half-plane poles, and 2 imaginary poles.

6.3

$$\text{Since } G(s) = \frac{K(s+20)}{s(s+2)(s+3)}, \quad T(s) = \frac{G(s)}{1+G(s)} = \frac{K(s+20)}{s^3 + 5s^2 + (6+K)s + 20K}$$

Form the Routh table.

s^3	1	$(6+K)$
s^2	5	$20K$
s^1	$\frac{30-15K}{5}$	
s^0	$20K$	

From the s^1 row, $K < 2$. From the s^0 row, $K > 0$. Thus, for stability, $0 < K < 2$.

6.4

First find

$$\begin{aligned} |s\mathbf{I} - \mathbf{A}| &= \left| \begin{bmatrix} s & 0 & 0 \\ 0 & s & 0 \\ 0 & 0 & s \end{bmatrix} - \begin{bmatrix} 2 & 1 & 1 \\ 1 & 7 & 1 \\ -3 & 4 & -5 \end{bmatrix} \right| = \left| \begin{array}{ccc} (s-2) & -1 & -1 \\ -1 & (s-7) & -1 \\ 3 & -4 & (s+5) \end{array} \right| \\ &= s^3 - 4s^2 - 33s + 51 \end{aligned}$$

Now form the Routh table.

s^3	1	-33
s^2	-4	51
s^1	-20.25	
s^0	51	

There are two sign changes. Thus, there are two rhp poles and one lhp pole.

CHAPTER 7

7.1

a. First check stability.

$$T(s) = \frac{G(s)}{1 + G(s)} = \frac{10s^2 + 500s + 6000}{s^3 + 70s^2 + 1375s + 6000} = \frac{10(s + 30)(s + 20)}{(s + 26.03)(s + 37.89)(s + 6.085)}$$

Poles are in the lhp. Therefore, the system is stable. Stability also could be checked via Routh-Hurwitz using the denominator of $T(s)$. Thus,

$$15u(t) : e_{step}(\infty) = \frac{15}{1 + \lim_{s \rightarrow 0} G(s)} = \frac{15}{1 + \infty} = 0$$

$$15tu(t) : e_{ramp}(\infty) = \frac{15}{\lim_{s \rightarrow 0} sG(s)} = \frac{15}{\frac{10 \cdot 20 \cdot 30}{25 \cdot 35}} = 2.1875$$

$$15t^2u(t) : e_{parabola}(\infty) = \frac{15}{\lim_{s \rightarrow 0} s^2 G(s)} = \frac{30}{0} = \infty, \text{ since } L[15t^2] = \frac{30}{s^3}$$

b. First check stability.

$$\begin{aligned} T(s) &= \frac{G(s)}{1 + G(s)} = \frac{10s^2 + 500s + 6000}{s^5 + 110s^4 + 3875s^3 + 4.37e04s^2 + 500s + 6000} \\ &= \frac{10(s + 30)(s + 20)}{(s + 50.01)(s + 35)(s + 25)(s^2 - 7.189e - 04s + 0.1372)} \end{aligned}$$

From the second-order term in the denominator, we see that the system is unstable. Instability could also be determined using the Routh-Hurwitz criteria on the denominator of $T(s)$. Since the system is unstable, calculations about steady-state error cannot be made.

7.2

a. The system is stable, since

$$T(s) = \frac{G(s)}{1 + G(s)} = \frac{1000(s + 8)}{(s + 9)(s + 7) + 1000(s + 8)} = \frac{1000(s + 8)}{s^2 + 1016s + 8063}$$

and is of Type 0. Therefore,

$$K_p = \lim_{s \rightarrow 0} G(s) = \frac{1000 \cdot 8}{7 \cdot 9} = 127; K_v = \lim_{s \rightarrow 0} sG(s) = 0;$$

and $K_a = \lim_{s \rightarrow 0} s^2 G(s) = 0$

b.

$$e_{step}(\infty) = \frac{1}{1 + \lim_{s \rightarrow 0} G(s)} = \frac{1}{1 + 127} = 7.8e - 03$$

$$e_{ramp}(\infty) = \frac{1}{\lim_{s \rightarrow 0} sG(s)} = \frac{1}{0} = \infty$$

$$e_{parabola}(\infty) = \frac{1}{\lim_{s \rightarrow 0} s^2 G(s)} = \frac{1}{0} = \infty$$

7.3

System is stable for positive K . System is Type 0. Therefore, for a step input $e_{step}(\infty) = \frac{1}{1 + K_p} = 0.1$. Solving for K_p yields $K_p = 9 = \lim_{s \rightarrow 0} G(s) = \frac{12K}{14 \cdot 18}$; from which we obtain $K = 189$.

7.4

System is stable. Since $G_1(s) = 1000$, and $G_2(s) = \frac{(s+2)}{(s+4)}$,

$$e_D(\infty) = -\frac{1}{\lim_{s \rightarrow 0} \frac{1}{G_2(s)} + \lim_{s \rightarrow 0} G_1(s)} = \frac{1}{2 + 1000} = -9.98e - 04$$

7.5

System is stable. Create a unity-feedback system, where $H_e(s) = \frac{1}{s+1} - 1 = \frac{-s}{s+1}$

The system is as follows:

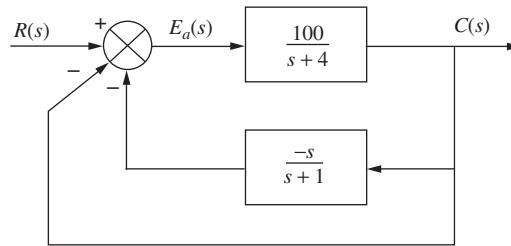

Thus,

$$G_e(s) = \frac{G(s)}{1 + G(s)H_e(s)} = \frac{\frac{100}{(s+4)}}{1 - \frac{100s}{(s+1)(s+4)}} = \frac{100(s+1)}{s^2 - 95s + 4}$$

Hence, the system is Type 0. Evaluating K_p yields

$$K_p = \frac{100}{4} = 25$$

The steady-state error is given by

$$e_{step}(\infty) = \frac{1}{1 + K_p} = \frac{1}{1 + 25} = 3.846e - 02$$

7.6

Since $G(s) = \frac{K(s+7)}{s^2 + 2s + 10}$, $e(\infty) = \frac{1}{1 + K_p} = \frac{1}{1 + \frac{7K}{10}} = \frac{10}{10 + 7K}$.

Calculating the sensitivity, we get

$$S_{e:K} = \frac{K}{e} \frac{\partial e}{\partial K} = \frac{K}{\left(\frac{10}{10 + 7K}\right)} \frac{(-10)7}{(10 + 7K)^2} = -\frac{7K}{10 + 7K}$$

7.7

Given

$$\mathbf{A} = \begin{bmatrix} 0 & 1 \\ -3 & -6 \end{bmatrix}; \mathbf{B} = \begin{bmatrix} 0 \\ 1 \end{bmatrix}; \mathbf{C} = [1 \quad 1]; \mathbf{R}(s) = \frac{1}{s}.$$

Using the final value theorem,

$$\begin{aligned} e_{step}(\infty) &= \lim_{s \rightarrow 0} sR(s) \left[1 - \mathbf{C}(s\mathbf{I} - \mathbf{A})^{-1}\mathbf{B} \right] = \lim_{s \rightarrow 0} \left[1 - [1 \quad 1] \begin{bmatrix} s & -1 \\ 3 & s+6 \end{bmatrix}^{-1} \begin{bmatrix} 0 \\ 1 \end{bmatrix} \right] \\ &= \lim_{s \rightarrow 0} \left[1 - [1 \quad 1] \frac{\begin{bmatrix} s+6 & 1 \\ -3s & s \end{bmatrix}}{s^2 + 6s + 3} \begin{bmatrix} 0 \\ 1 \end{bmatrix} \right] = \lim_{s \rightarrow 0} \frac{s^2 + 5s + 2}{s^2 + 6s + 3} = \frac{2}{3} \end{aligned}$$

Using input substitution,

$$\begin{aligned} step(\infty) &= 1 + \mathbf{C}\mathbf{A}^{-1}\mathbf{B} = 1 - [1 \quad 1] \begin{bmatrix} 0 & 1 \\ -3 & -6 \end{bmatrix}^{-1} \begin{bmatrix} 0 \\ 1 \end{bmatrix} \\ &= 1 + [1 \quad 1] \frac{\begin{bmatrix} -6 & -1 \\ 3 & 0 \end{bmatrix}}{3} \begin{bmatrix} 0 \\ 1 \end{bmatrix} = 1 + [1 \quad 1] \begin{bmatrix} -\frac{1}{3} \\ 0 \end{bmatrix} = \frac{2}{3} \end{aligned}$$

CHAPTER 8

8.1

$$\begin{aligned} \mathbf{a.} \quad F(-7 + j9) &= \frac{(-7 + j9 + 2)(-7 + j9 + 4)0.0339}{(-7 + j9)(-7 + j9 + 3)(-7 + j9 + 6)} = \frac{(-5 + j9)(-3 + j9)}{(-7 + j9)(-4 + j9)(-1 + j9)} \\ &= \frac{(-66 - j72)}{(944 - j378)} = -0.0339 - j0.0899 = 0.096 \angle -110.7^\circ \end{aligned}$$

b. The arrangement of vectors is shown as follows:

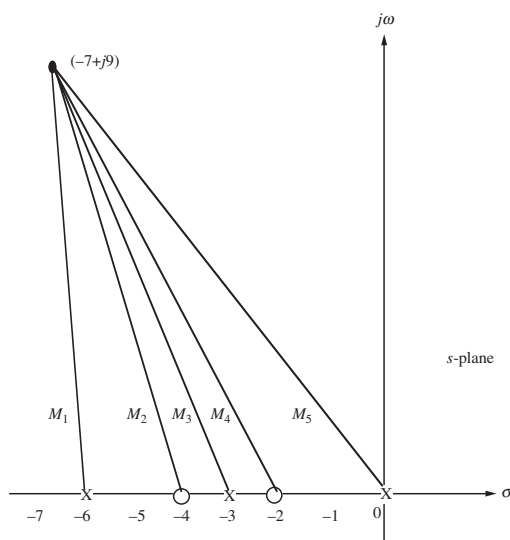

From the diagram,

$$\begin{aligned} F(-7 + j9) &= \frac{M_2 M_4}{M_1 M_3 M_5} = \frac{(-3 + j9)(-5 + j9)}{(-1 + j9)(-4 + j9)(-7 + j9)} = \frac{(-66 - j72)}{(944 - j378)} \\ &= -0.0339 - j0.0899 = 0.096 \angle -110.7^\circ \end{aligned}$$

8.2

a. First draw the vectors.

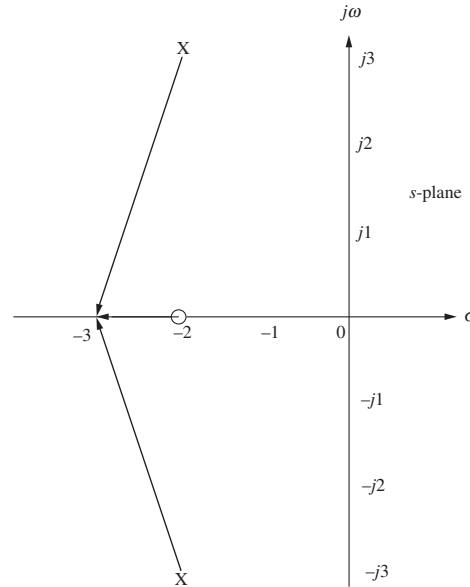

From the diagram,

$$\sum \text{angles} = 180^\circ - \tan^{-1}\left(\frac{-3}{-1}\right) - \tan^{-1}\left(\frac{-3}{1}\right) = 180^\circ - 108.43^\circ + 108.43^\circ = 180^\circ.$$

b. Since the angle is 180° , the point is on the root locus.

$$\text{c. } K = \frac{\prod \text{pole lengths}}{\prod \text{zero lengths}} = \frac{(\sqrt{1^2 + 3^2})(\sqrt{1^2 + 3^2})}{1} = 10$$

8.3

First, find the asymptotes.

$$\sigma_a = \frac{\sum \text{poles} - \sum \text{zeros}}{\# \text{poles} - \# \text{zeros}} = \frac{(-2 - 4 - 6) - (0)}{3 - 0} = -4$$

$$\theta_a = \frac{(2k + 1)\pi}{3} = \frac{\pi}{3}, \pi, \frac{5\pi}{3}$$

Next draw root locus following the rules for sketching.

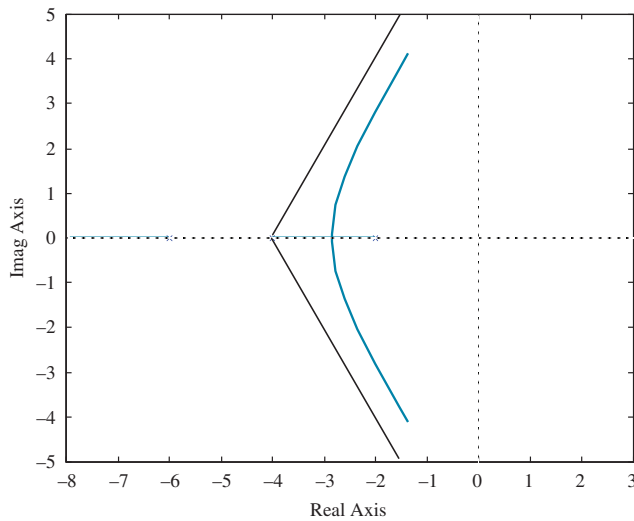

8.4

a.

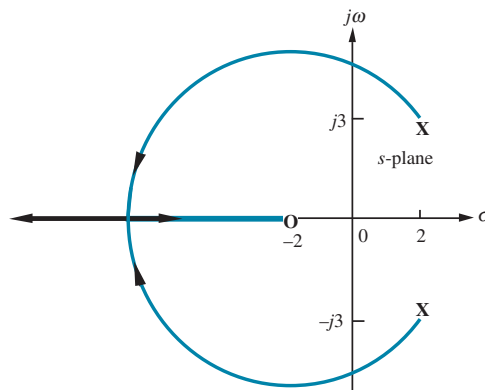

b. Using the Routh-Hurwitz criteria, we first find the closed-loop transfer function.

$$T(s) = \frac{G(s)}{1 + G(s)} = \frac{K(s+2)}{s^2 + (K-4)s + (2K+13)}$$

Using the denominator of $T(s)$, make a Routh table.

s^2	1	$2K+13$
s^1	$K-4$	0
s^0	$2K+13$	0

We get a row of zeros for $K = 4$. From the s^2 row with $K = 4$, $s^2 + 21 = 0$. From which we evaluate the imaginary axis crossing at $\sqrt{21}$.

c. From part (b), $K = 4$.

d. Searching for the minimum gain to the left of -2 on the real axis yields -7 at a gain of 18. Thus the break-in point is at -7 .

- e. First, draw vectors to a point ε close to the complex pole.

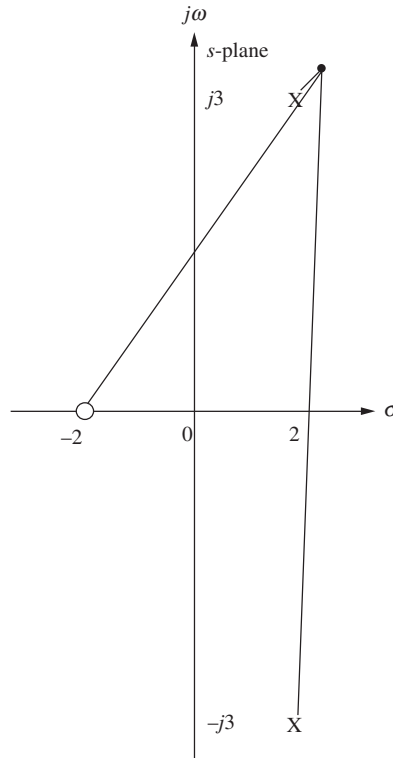

At the point ε close to the complex pole, the angles must add up to zero. Hence, angle from zero – angle from pole in 4th quadrant – angle from pole in 1st quadrant = 180° , or $\tan^{-1}\left(\frac{3}{4}\right) - 90^\circ - \theta = 180^\circ$. Solving for the angle of departure, $\theta = -233.1$.

8.5

- a.

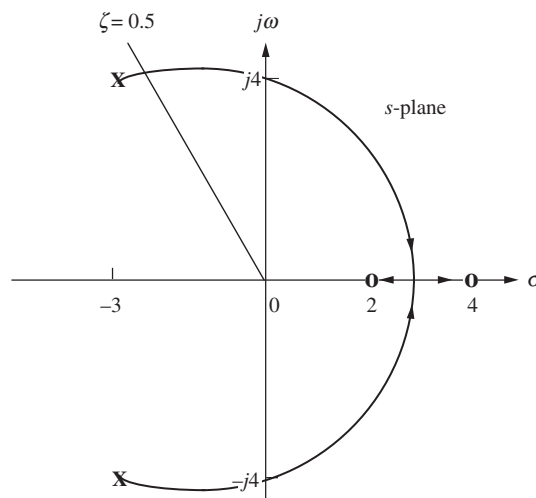

- b. Search along the imaginary axis and find the 180° point at $s = \pm j4.06$.
- c. For the result in part (b), $K = 1$.
- d. Searching between 2 and 4 on the real axis for the minimum gain yields the break-in at $s = 2.89$.
- e. Searching along $\zeta = 0.5$ for the 180° point we find $s = -2.42 + j4.18$.
- f. For the result in part (e), $K = 0.108$.
- g. Using the result from part (c) and the root locus, $K < 1$.

8.6

a.

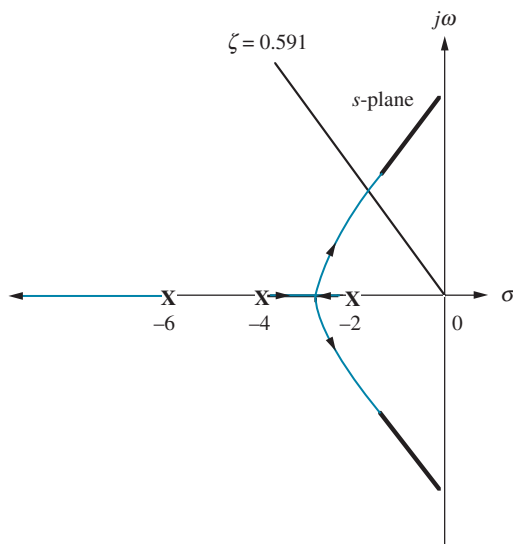

- b. Searching along the $\zeta = 0.591$ (10% overshoot) line for the 180° point yields $-2.028 + j2.768$ with $K = 45.55$.
- c. $T_s = \frac{4}{|\text{Re}|} = \frac{4}{2.028} = 1.97 \text{ s}$; $T_p = \frac{\pi}{|\text{Im}|} = \frac{\pi}{2.768} = 1.13 \text{ s}$; $\omega_n T_r = 1.8346$ from the rise-time chart and graph in Chapter 4. Since ω_n is the radial distance to the pole, $\omega_n = \sqrt{2.028^2 + 2.768^2} = 3.431$. Thus, $T_r = 0.53 \text{ s}$; since the system is Type 0, $K_p = \frac{K}{2 \cdot 4 \cdot 6} = \frac{45.55}{48} = 0.949$. Thus,

$$e_{step}(\infty) = \frac{1}{1 + K_p} = 0.51.$$

- d. Searching the real axis to the left of -6 for the point whose gain is 45.55, we find -7.94 . Comparing this value to the real part of the dominant pole, -2.028 , we find that it is not five times further. The second-order approximation is not valid.

8.7

Find the closed-loop transfer function and put it the form that yields p_i as the root locus variable. Thus,

$$T(s) = \frac{G(s)}{1 + G(s)} = \frac{100}{s^2 + p_i s + 100} = \frac{100}{(s^2 + 100) + p_i s} = \frac{\frac{100}{s^2 + 100}}{1 + \frac{p_i s}{s^2 + 100}}$$

Hence, $KG(s)H(s) = \frac{P_i s}{s^2 + 100}$. The following shows the root locus.

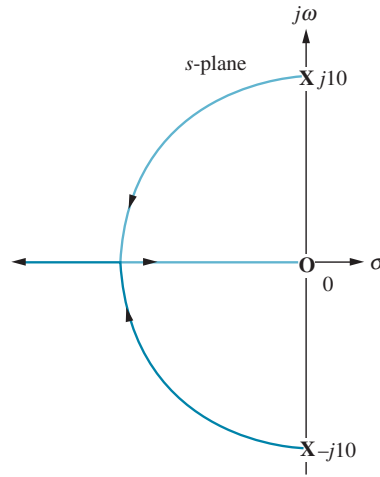

8.8

Following the rules for plotting the root locus of positive-feedback systems, we obtain the following root locus:

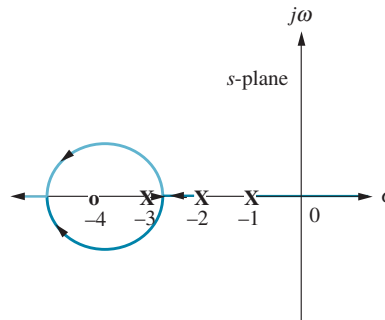

8.9

The closed-loop transfer function is $T(s) = \frac{K(s+1)}{s^2 + (K+2)s + K}$. Differentiating the denominator with respect to K yields

$$2s \frac{\partial s}{\partial K} + (K+2) \frac{\partial s}{\partial K} + (s+1) = (2s+K+2) \frac{\partial s}{\partial K} + (s+1) = 0$$

Solving for $\frac{\partial s}{\partial K}$, we get $\frac{\partial s}{\partial K} = \frac{-(s+1)}{(2s+K+2)}$. Thus, $S_{s:K} = \frac{K}{s} \frac{\partial s}{\partial K} = \frac{-K(s+1)}{s(2s+K+2)}$.

Substituting $K = 20$ yields $S_{s:K} = \frac{-10(s+1)}{s(s+11)}$.

Now find the closed-loop poles when $K = 20$. From the denominator of $T(s)$, $s_{1,2} = -21.05, -0.95$, when $K = 20$.

For the pole at -21.05 ,

$$\Delta s = s(S_{s:K}) \frac{\Delta K}{K} = -21.05 \left(\frac{-10(-21.05+1)}{-21.05(-21.05+11)} \right) 0.05 = -0.9975.$$

For the pole at -0.95 ,

$$\Delta s = s(S_{s:K}) \frac{\Delta K}{K} = 0.95 \left(\frac{-10(-0.95 + 1)}{-0.95(-0.95 + 11)} \right) 0.05 = -0.0025.$$

CHAPTER 9

9.1

- a. Searching along the 15% overshoot line, we find the point on the root locus at $-3.5 + j5.8$ at a gain of $K = 45.84$. Thus, for the uncompensated system, $K_v = \lim_{s \rightarrow 0} sG(s) = K/7 = 45.84/7 = 6.55$.

Hence, $e_{ramp_uncompensated}(\infty) = 1/K_v = 0.1527$.

- b. Compensator zero should be $20x$ further to the left than the compensator pole.

Arbitrarily select $G_c(s) = \frac{(s + 0.2)}{(s + 0.01)}$.

- c. Insert compensator and search along the 15% overshoot line and find the root locus at $-3.4 + j5.63$ with a gain, $K = 44.64$. Thus, for the compensated system,

$$K_v = \frac{44.64(0.2)}{(7)(0.01)} = 127.5 \text{ and } e_{ramp_compensated}(\infty) = \frac{1}{K_v} = 0.0078.$$

- d. $\frac{e_{ramp_uncompensated}}{e_{ramp_compensated}} = \frac{0.1527}{0.0078} = 19.58$

9.2

- a. Searching along the 15% overshoot line, we find the point on the root locus at $-3.5 + j5.8$ at a gain of $K = 45.84$. Thus, for the uncompensated system,

$$T_s = \frac{4}{|Re|} = \frac{4}{3.5} = 1.143 \text{ s.}$$

- b. The real part of the design point must be three times larger than the uncompensated pole's real part. Thus the design point is $3(-3.5) + j3(5.8) = -10.5 + j17.4$. The angular contribution of the plant's poles and compensator zero at the design point is 130.8° . Thus, the compensator pole must contribute $180^\circ - 130.8^\circ = 49.2^\circ$. Using the following diagram,

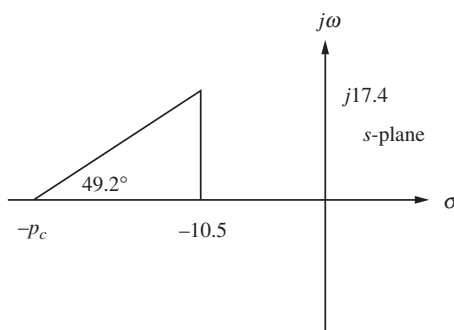

we find $\frac{17.4}{p_c - 10.5} = \tan 49.2^\circ$, from which, $p_c = 25.52$. Adding this pole, we find the gain at the design point to be $K = 476.3$. A higher-order closed-loop pole is found to be at -11.54 . This pole may not be close enough to the closed-loop zero at -10 . Thus, we should simulate the system to be sure the design requirements have been met.

9.3

- a. Searching along the 20% overshoot line, we find the point on the root locus at $-3.5 + j6.83$ at a gain of $K = 58.9$. Thus, for the uncompensated system,

$$T_s = \frac{4}{|\text{Re}|} = \frac{4}{3.5} = 1.143 \text{ s.}$$

- b. For the uncompensated system, $K_v = \lim_{s \rightarrow 0} sG(s) = K/7 = 58.9/7 = 8.41$. Hence, $e_{\text{ramp_uncompensated}}(\infty) = 1/K_v = 0.1189$.
- c. In order to decrease the settling time by a factor of 2, the design point is twice the uncompensated value, or $-7 + j13.66$. Adding the angles from the plant's poles and the compensator's zero at -3 to the design point, we obtain -100.8° . Thus, the compensator pole must contribute $180^\circ - 100.8^\circ = 79.2^\circ$. Using the following diagram,

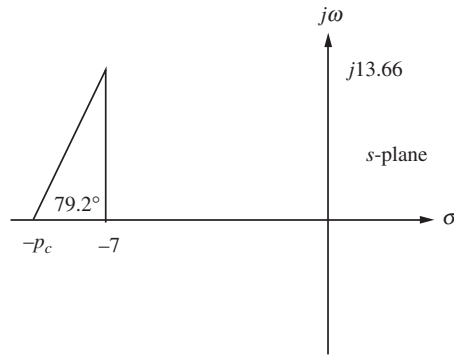

we find $\frac{13.66}{p_c - 7} = \tan 79.2^\circ$, from which, $p_c = 9.61$. Adding this pole, we find the gain at the design point to be $K = 204.9$.

Evaluating K_v for the lead-compensated system:

$$K_v = \lim_{s \rightarrow 0} sG(s)G_{\text{lead}} = K(3)/[(7)(9.61)] = (204.9)(3)/[(7)(9.61)] = 9.138.$$

K_v for the uncompensated system was 8.41. For a $10x$ improvement in steady-state error, K_v must be $(8.41)(10) = 84.1$. Since lead compensation gave us $K_v = 9.138$, we need an improvement of $84.1/9.138 = 9.2$. Thus, the lag compensator zero should be $9.2x$ further to the left than the compensator pole. Arbitrarily select

$$G_c(s) = \frac{(s + 0.092)}{(s + 0.01)}.$$

Using all plant and compensator poles, we find the gain at the design point to be $K = 205.4$. Summarizing the forward path with plant, compensator, and gain yields

$$G_e(s) = \frac{205.4(s + 3)(s + 0.092)}{s(s + 7)(9.61)(s + 0.01)}.$$

Higher-order poles are found at -0.928 and -2.6 . It would be advisable to simulate the system to see if there is indeed pole-zero cancellation.

9.4

The configuration for the system is shown in the figure below.

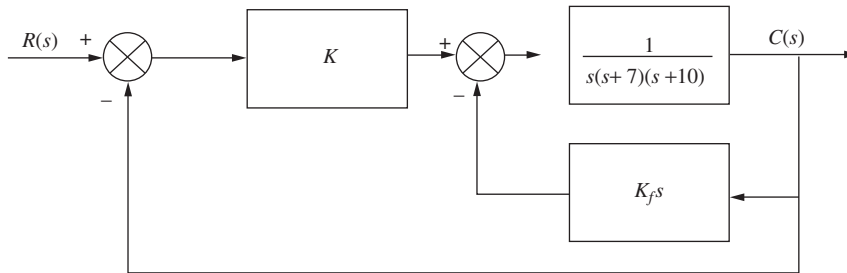

Minor-Loop Design:

For the minor loop, $G(s)H(s) = \frac{K_f}{(s+7)(s+10)}$. Using the following diagram, we find that the minor-loop root locus intersects the 0.7 damping ratio line at $-8.5 + j8.67$. The imaginary part was found as follows: $\theta = \cos^{-1}\zeta = 45.57^\circ$. Hence, $\frac{\text{Im}}{8.5} = \tan 45.57^\circ$, from which $\text{Im} = 8.67$.

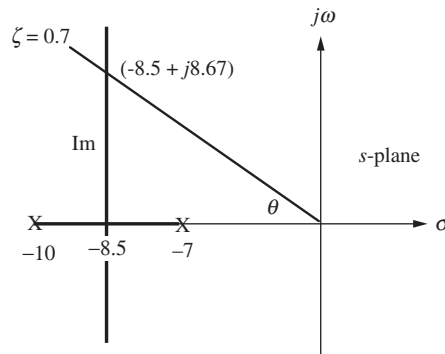

The gain, K_f , is found from the vector lengths as

$$K_f = \sqrt{1.5^2 + 8.67^2} \sqrt{1.5^2 + 8.67^2} = 77.42$$

Major-Loop Design:

Using the closed-loop poles of the minor loop, we have an equivalent forward-path transfer function of

$$G_e(s) = \frac{K}{s(s+8.5+j8.67)(s+8.5-j8.67)} = \frac{K}{s(s^2+17s+147.4)}$$

Using the three poles of $G_e(s)$ as open-loop poles to plot a root locus, we search along $\zeta = 0.5$ and find that the root locus intersects this damping ratio line at $-4.34 + j7.51$ at a gain, $K = 626.3$.

9.5

- a. An active PID controller must be used. We use the circuit shown in the following figure:

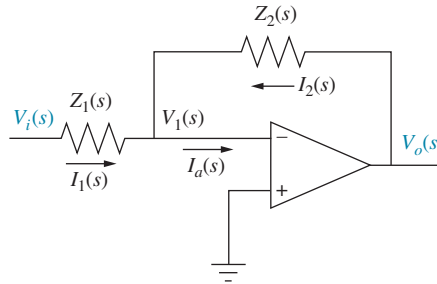

where the impedances are shown below as follows:

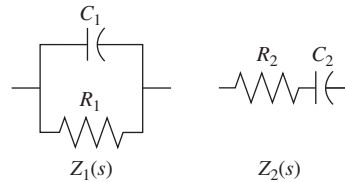

Matching the given transfer function with the transfer function of the PID controller yields

$$G_c(s) = \frac{(s + 0.1)(s + 5)}{s} = \frac{s^2 + 5.1s + 0.5}{s} = s + 5.1 + \frac{0.5}{s}$$

$$= - \left[\left(\frac{R_2}{R_1} + \frac{C_1}{C_2} \right) + R_2 C_1 s + \frac{R_1 C_2}{s} \right]$$

Equating coefficients

$$\frac{1}{R_1 C_2} = 0.5 \quad (1)$$

$$R_2 C_1 = 1 \quad (2)$$

$$\left(\frac{R_2}{R_1} + \frac{C_1}{C_2} \right) = 5.1 \quad (3)$$

In Eq. (2) we arbitrarily let $C_1 = 10^{-5}$. Thus, $R_2 = 10^5$. Using these values along with Eqs. (1) and (3) we find $C_2 = 100\mu F$ and $R_1 = 20\text{ k}\Omega$.

- b. The lag-lead compensator can be implemented with the following passive network, since the ratio of the lead pole-to-zero is the inverse of the ratio of the lag pole-to-zero:

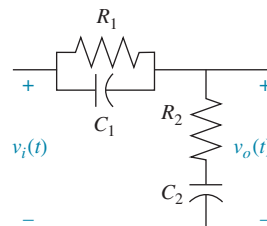

Matching the given transfer function with the transfer function of the passive lag-lead compensator yields

$$G_c(s) = \frac{(s + 0.1)(s + 2)}{(s + 0.01)(s + 20)} = \frac{(s + 0.1)(s + 2)}{s^2 + 20.01s + 0.2}$$

$$= \frac{\left(s + \frac{1}{R_1 C_1}\right) \left(s + \frac{1}{R_2 C_2}\right)}{s^2 + \left(\frac{1}{R_1 C_1} + \frac{1}{R_2 C_2} + \frac{1}{R_2 C_1}\right)s + \frac{1}{R_1 R_2 C_1 C_2}}$$

Equating coefficients

$$\frac{1}{R_1 C_1} = 0.1 \quad (1)$$

$$\frac{1}{R_2 C_2} = 0.1 \quad (2)$$

$$\left(\frac{1}{R_1 C_1} + \frac{1}{R_2 C_2} + \frac{1}{R_2 C_1}\right) = 20.01 \quad (3)$$

Substituting Eqs. (1) and (2) in Eq. (3) yields

$$\frac{1}{R_2 C_1} = 17.91 \quad (4)$$

Arbitrarily letting $C_1 = 100 \mu F$ in Eq. (1) yields $R_1 = 100 k\Omega$.

Substituting $C_1 = 100 \mu F$ into Eq. (4) yields $R_2 = 558 k\Omega$.

Substituting $R_2 = 558 k\Omega$ into Eq. (2) yields $C_2 = 900 \mu F$.

CHAPTER 10

10.1

a.

$$G(s) = \frac{1}{(s + 2)(s + 4)}; \quad G(j\omega) = \frac{1}{(8 + \omega^2) + j6\omega}$$

$$M(\omega) = \sqrt{(8 - \omega^2)^2 + (6\omega)^2}$$

$$\text{For } \omega < \sqrt{8}, \phi(\omega) = -\tan^{-1}\left(\frac{6\omega}{8 - \omega^2}\right).$$

$$\text{For } \omega > \sqrt{8}, \phi(\omega) = -\left(\pi + \tan^{-1}\left[\frac{6\omega}{8 - \omega^2}\right]\right).$$

b.

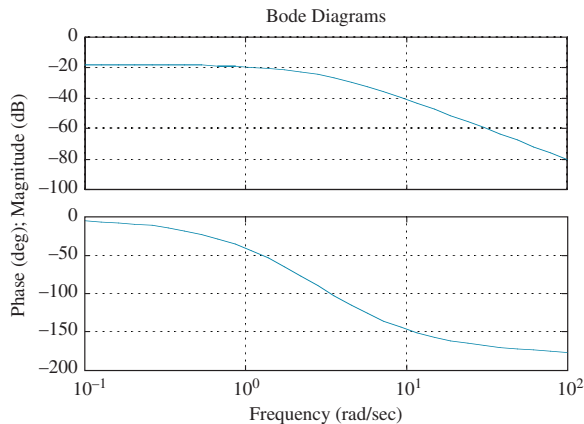

c.

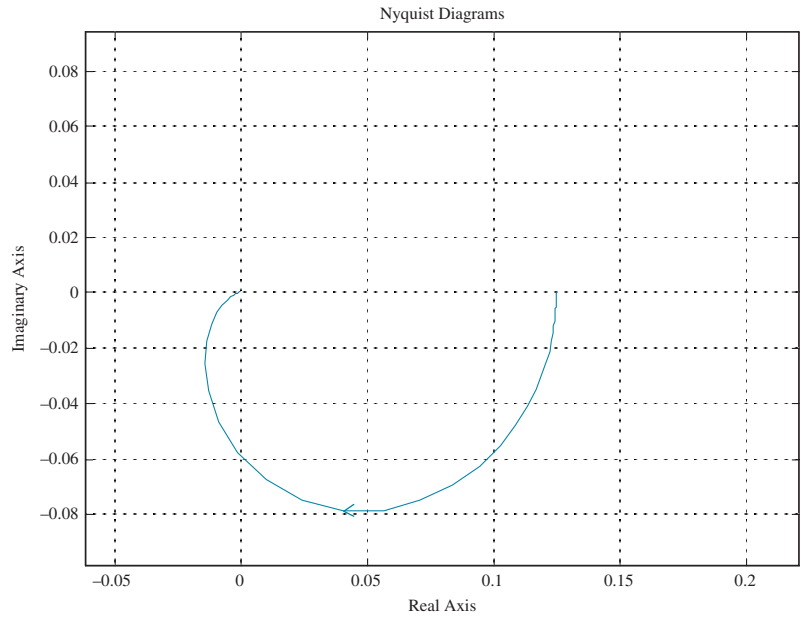

10.2

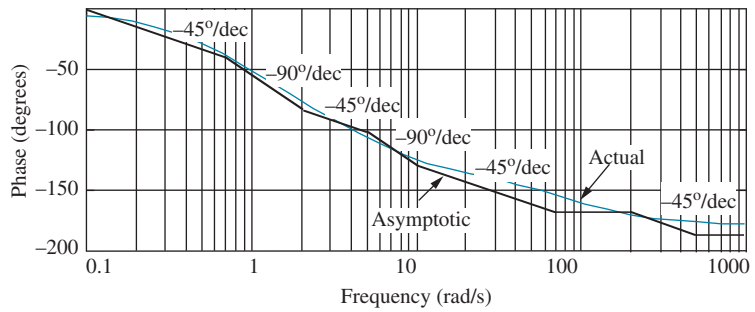
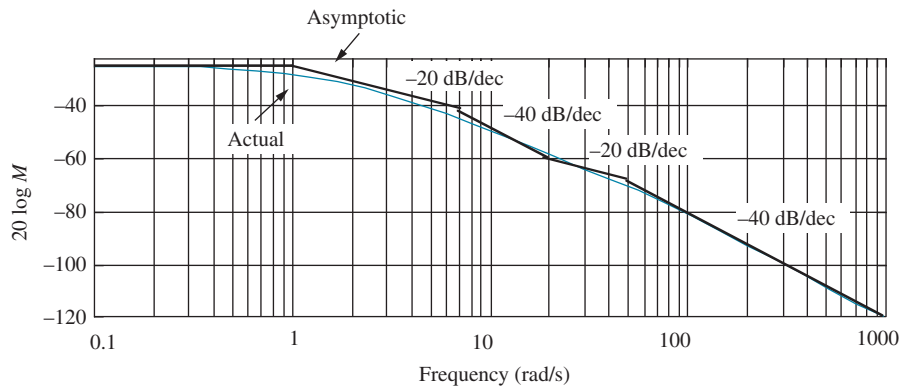

10.3

The frequency response is $1/8$ at an angle of zero degrees at $\omega = 0$. Each pole rotates 90° in going from $\omega = 0$ to $\omega = \infty$. Thus, the resultant rotates -180° while its magnitude goes to zero. The result is shown below.

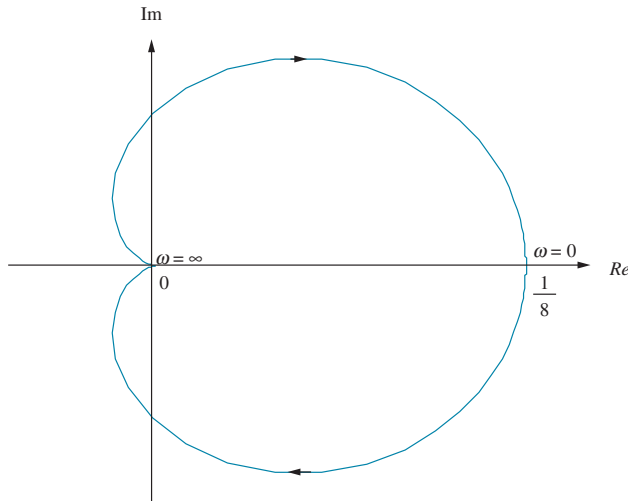

10.4

a. The frequency response is $1/48$ at an angle of zero degrees at $\omega = 0$. Each pole rotates 90° in going from $\omega = 0$ to $\omega = \infty$. Thus, the resultant rotates -270° while its magnitude goes to zero. The result is shown below.

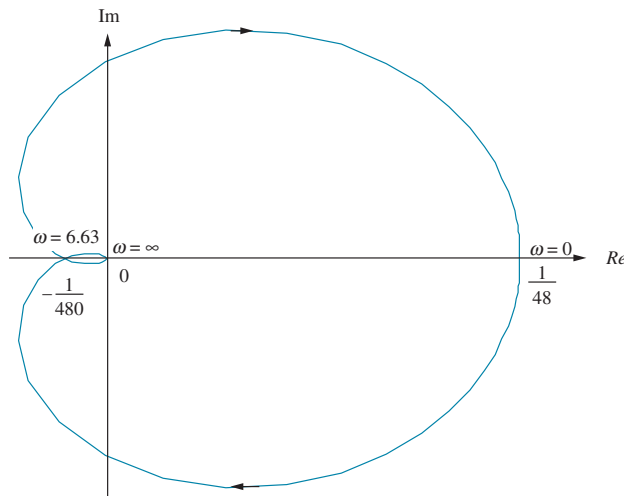

b. Substituting $j\omega$ into $G(s) = \frac{1}{(s+2)(s+4)(s+6)} = \frac{1}{s^3 + 12s^2 + 44s + 48}$ and simplifying, we obtain $G(j\omega) = \frac{(48 - 12\omega^2) - j(44\omega - \omega^3)}{\omega^6 + 56\omega^4 + 784\omega^2 + 2304}$. The Nyquist diagram crosses the real axis when the imaginary part of $G(j\omega)$ is zero. Thus, the Nyquist diagram crosses the real axis at $\omega^2 = 44$, or $\omega = \sqrt{44} = 6.63$ rad/s. At this frequency $G(j\omega) = -\frac{1}{480}$. Thus, the system is stable for $K < 480$.

10.5

If $K = 100$, the Nyquist diagram will intersect the real axis at $-100/480$. Thus, $G_M = 20 \log \frac{480}{100} = 13.62$ dB. From Skill-Assessment Exercise Solution 10.4, the 180° frequency is 6.63 rad/s.

10.6

a.

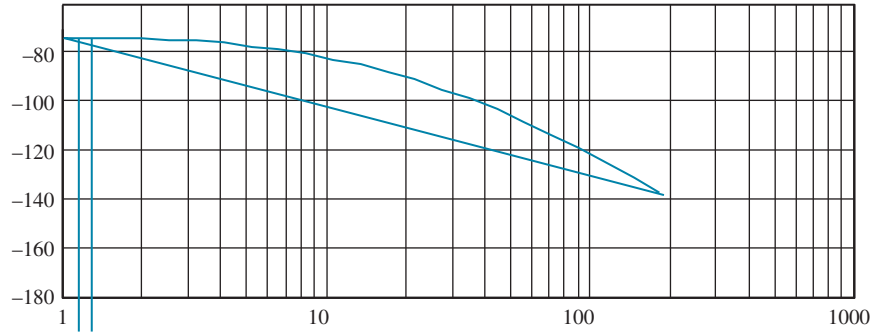

10.8

For both parts find that $G(j\omega) = \frac{160}{27} * \frac{(6750000 - 101250\omega^2) + j1350(\omega^2 - 1350)\omega}{\omega^6 + 2925\omega^4 + 1072500\omega^2 + 25000000}$.

For a range of values for ω , superimpose $G(j\omega)$ on the **a.** M and N circles, and on the **b.** Nichols chart.

a.

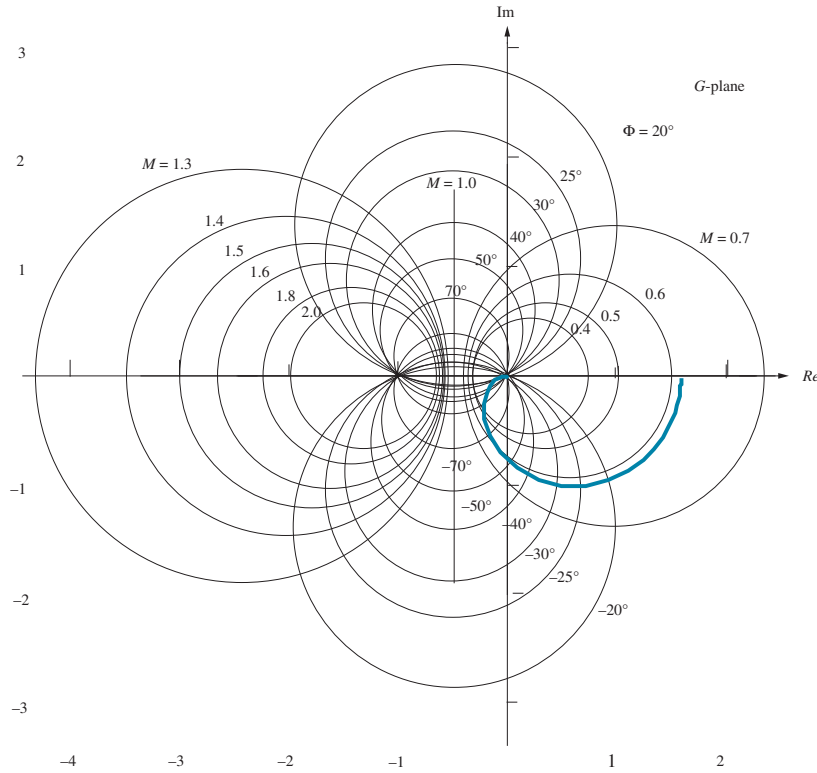

b.

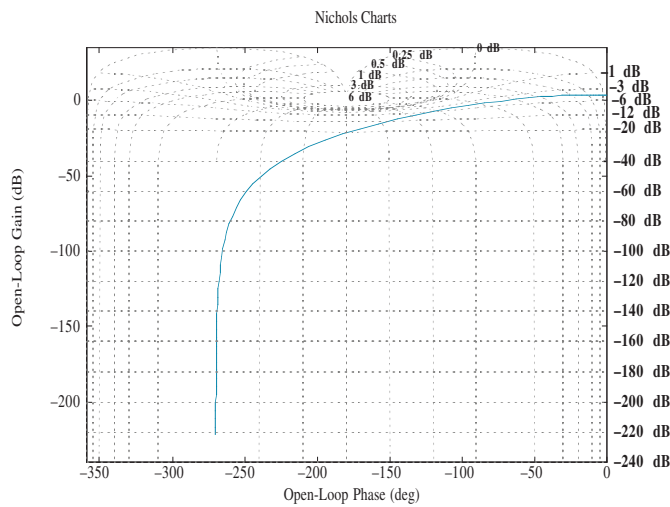

Plotting the closed-loop frequency response from **a.** or **b.** yields the following plot:

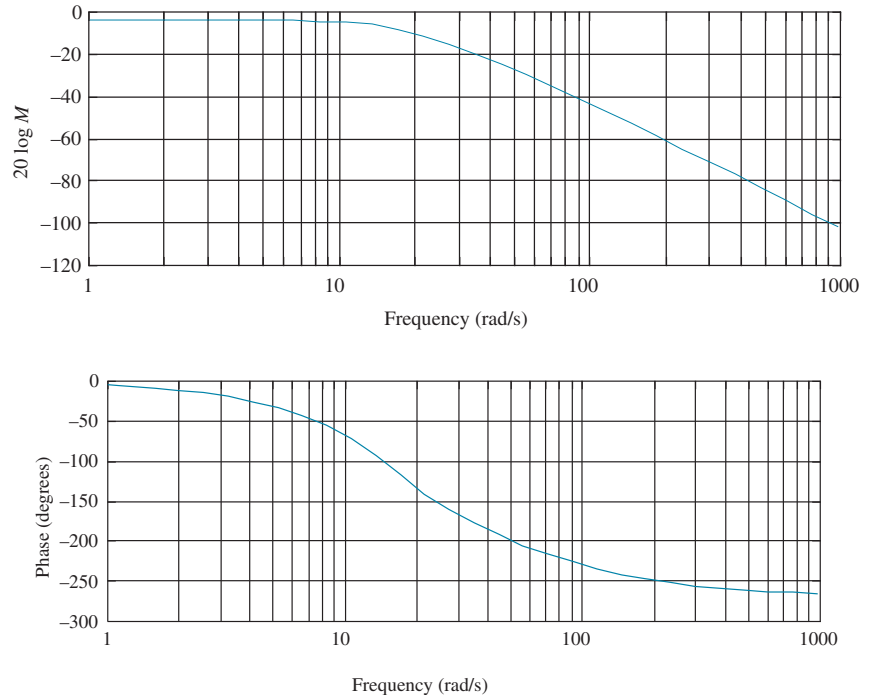

10.9

The open-loop frequency response is shown in the following figure:

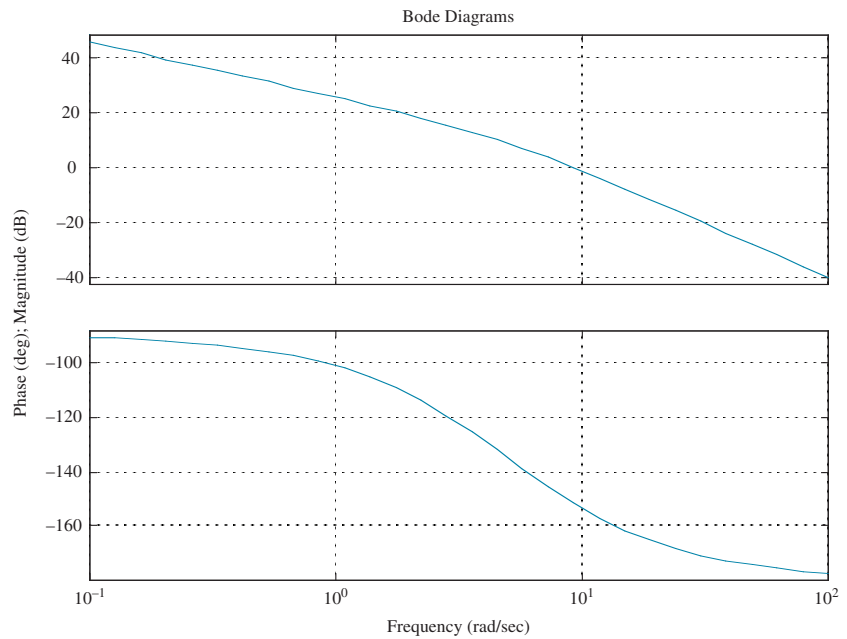

The open-loop frequency response is -7 at $\omega = 14.5$ rad/s. Thus, the estimated bandwidth is $\omega_{WB} = 14.5$ rad/s. The open-loop frequency response plot goes through zero dB at a frequency of 9.4 rad/s, where the phase is 151.98° . Hence, the phase margin is $180^\circ - 151.98^\circ = 28.02^\circ$. This phase margin corresponds to

$$\zeta = 0.25. \text{ Therefore, } \%OS = e^{-\left(\zeta\pi/\sqrt{1-\zeta^2}\right)} \times 100 = 44.4\%$$

$$T_s = \frac{4}{\omega_{BW}\zeta} \sqrt{(1-2\zeta^2) + \sqrt{4\zeta^4 - 4\zeta^2 + 2}} = 1.64 \text{ s and}$$

$$T_p = \frac{\pi}{\omega_{BW}\sqrt{1-\zeta^2}} \sqrt{(1-2\zeta^2) + \sqrt{4\zeta^4 - 4\zeta^2 + 2}} = 0.33 \text{ s}$$

10.10

The initial slope is 40 dB/dec. Therefore, the system is Type 2. The initial slope intersects 0 dB at $\omega = 9.5$ rad/s. Thus, $K_a = 9.5^2 = 90.25$ and $K_p = K_v = \infty$.

10.11

a. Without delay, $G(j\omega) = \frac{10}{j\omega(j\omega+1)} = \frac{10}{\omega(-\omega+j)}$, from which the zero dB frequency is found as follows: $M = \frac{10}{\omega\sqrt{\omega^2+1}} = 1$. Solving for ω , $\omega\sqrt{\omega^2+1} = 10$, or after squaring both sides and rearranging, $\omega^4 + \omega^2 - 100 = 0$. Solving for the roots, $\omega^2 = -10.51, 9.51$. Taking the square root of the positive root, we find the 0 dB frequency to be 3.08 rad/s. At this frequency, the phase angle, $\phi = -\angle(-\omega+j) = -\angle(-3.08+j) = -162^\circ$. Therefore the phase margin is $180^\circ - 162^\circ = 18^\circ$.

b. With a delay of 0.1 s,

$$\begin{aligned} \phi &= -\angle(-\omega+j) - \omega T = -\angle(-3.08+j) - (3.08)(0.1)(180/\pi) \\ &= -162 - 17.65 = -179.65^\circ \end{aligned}$$

Therefore the phase margin is $180^\circ - 179.65^\circ = 0.35^\circ$. Thus, the system is stable.

c. With a delay of 3 s,

$$\begin{aligned} \phi &= -\angle(-\omega+j) - \omega T = -\angle(-3.08+j) - (3.08)(3)(180/\pi) = -162^\circ - 529.41^\circ \\ &= -691.41^\circ = 28.59 \text{ deg.} \end{aligned}$$

Therefore the phase margin is $28.59 - 180 = -151.41$ deg. Thus, the system is unstable.

10.12

Drawing judiciously selected slopes on the magnitude and phase plot as shown below yields a first estimate.

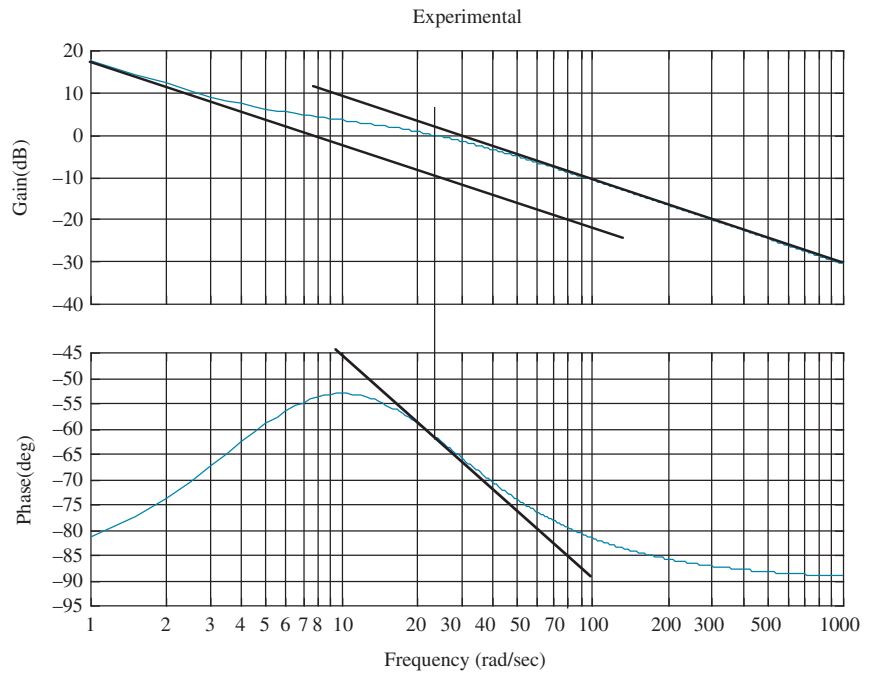

We see an initial slope on the magnitude plot of -20 dB/dec. We also see a final -20 dB/dec slope with a break frequency around 21 rad/s. Thus, an initial estimate is $G_1(s) = \frac{1}{s(s+21)}$. Subtracting $G_1(s)$ from the original frequency response yields the frequency response shown below.

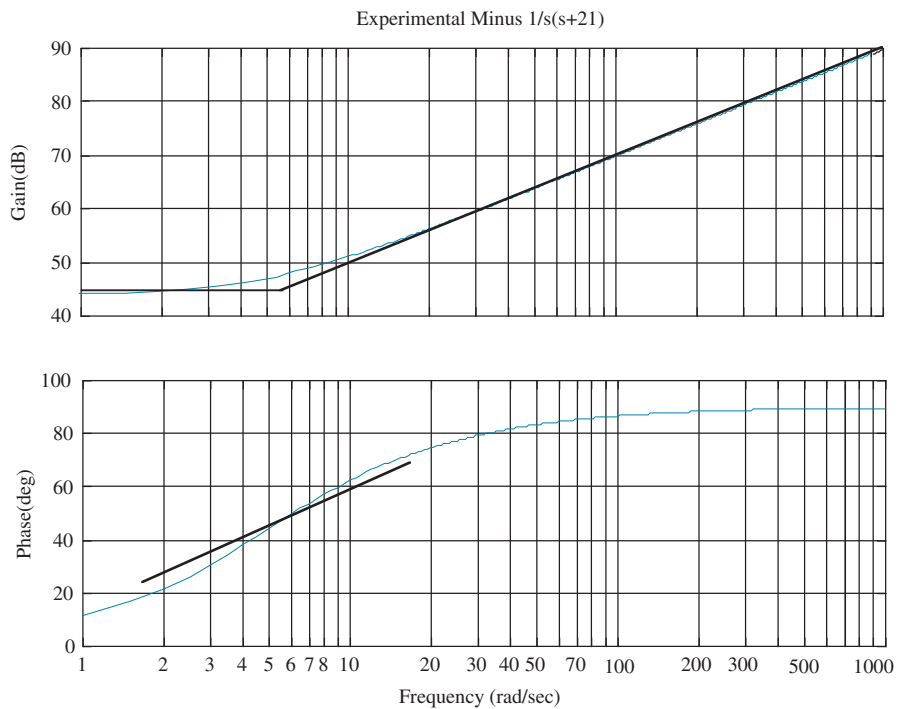

Drawing judiciously selected slopes on the magnitude and phase plot as shown yields a final estimate. We see first-order zero behavior on the magnitude and phase plots with a break frequency of about 5.7 rad/s and a dc gain of about 44 dB = $20\log(5.7K)$, or $K = 27.8$. Thus, we estimate $G_2(s) = 27.8(s + 7)$. Thus, $G(s) = G_1(s)G_2(s) = \frac{27.8(s + 5.7)}{s(s + 21)}$. It is interesting to note that the original problem was developed from $G(s) = \frac{30(s + 5)}{s(s + 20)}$.

CHAPTER 11

11.1

The Bode plot for $K = 1$ is shown below.

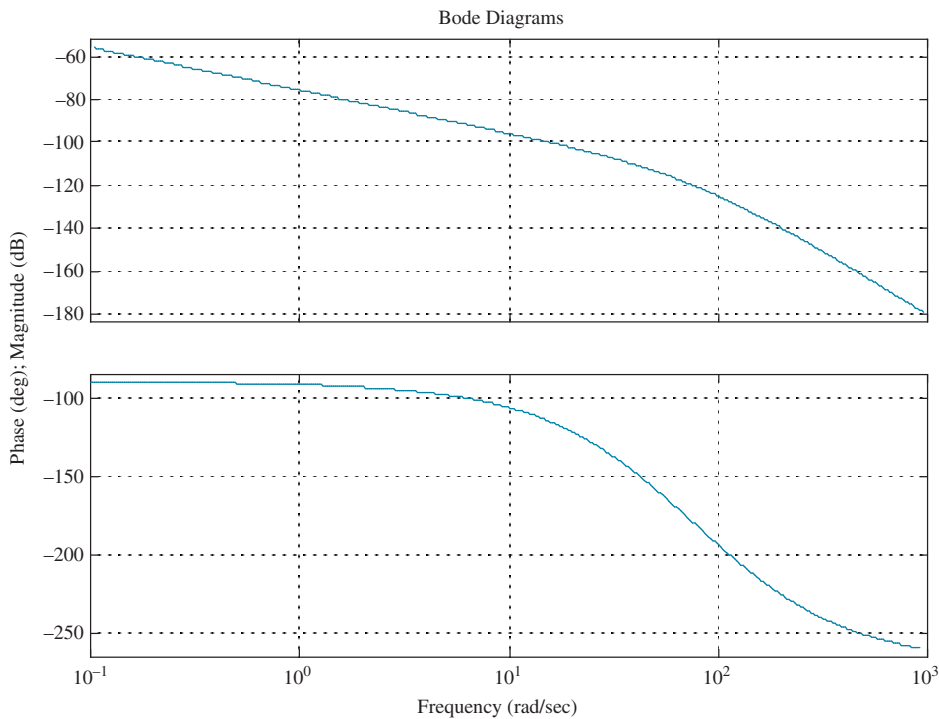

A 20% overshoot requires $\zeta = \frac{-\log\left(\frac{\%}{100}\right)}{\sqrt{\pi^2 + \log^2\left(\frac{\%}{100}\right)}} = 0.456$. This damping ratio implies a

phase margin of 48.10, which is obtained when the phase angle = $-180 + 48.10 = 131.9^\circ$. This phase angle occurs at $\omega = 27.6$ rad/s. The magnitude at this frequency is 5.15×10^{-6} . Since the magnitude must be unity $K = \frac{1}{5.15 \times 10^{-6}} = 194,200$.

11.2

To meet the steady-state error requirement, $K = 1,942,000$. The Bode plot for this gain is shown below.

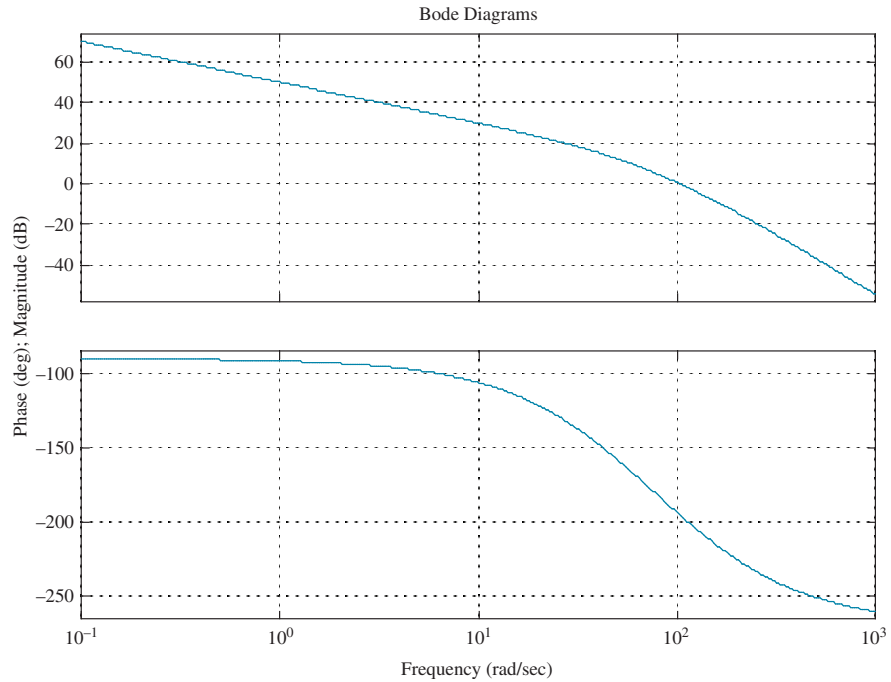

A 20% overshoot requires $\zeta = \frac{-\log\left(\frac{\%}{100}\right)}{\sqrt{\pi^2 + \log^2\left(\frac{\%}{100}\right)}} = 0.456$. This damping ratio

implies a phase margin of 48.1° . Adding 10° to compensate for the phase angle contribution of the lag, we use 58.1° . Thus, we look for a phase angle of $-180^\circ + 58.1^\circ = -121.9^\circ$. The frequency at which this phase occurs is 20.4 rad/s. At this frequency the magnitude plot must go through zero dB. Presently, the magnitude plot is 23.2 dB. Therefore draw the high frequency asymptote of the lag compensator at -23.2 dB/dec slope. Insert a break at $0.1(20.4) = 2.04$ rad/s. At this frequency, draw -23.2 dB/dec slope until it intersects 0 dB. The frequency of intersection will be the low frequency break or 0.141 rad/s. Hence the compensator is $G_c(s) = K_c \frac{(s + 2.04)}{(s + 0.141)}$, where the gain is chosen to yield 0 dB at low frequencies, or $K_c = 0.141/2.04 = 0.0691$. In summary,

$$G_c(s) = 0.0691 \frac{(s + 2.04)}{(s + 0.141)} \text{ and } G(s) = \frac{1,942,000}{s(s + 50)(s + 120)}$$

11.3

A 20% overshoot requires $\zeta = \frac{-\log\left(\frac{\%}{100}\right)}{\sqrt{\pi^2 + \log^2\left(\frac{\%}{100}\right)}} = 0.456$. The required bandwidth

is then calculated as $\omega_{BW} = \frac{4}{T_s \zeta} \sqrt{(1 - 2\zeta^2) + \sqrt{4\zeta^4 - 4\zeta^2 + 2}} = 57.9$ rad/s. In order to meet the steady-state error requirement of $K_v = 50 = \frac{K}{(50)(120)}$, we calculate $K = 300,000$. The uncompensated Bode plot for this gain is shown below.

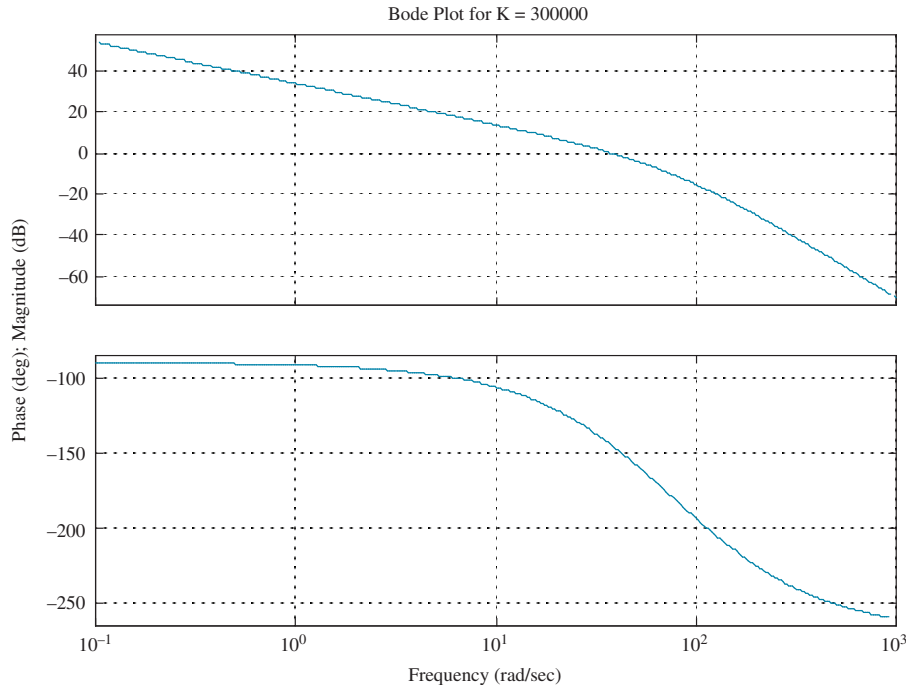

The uncompensated system's phase margin measurement is taken where the magnitude plot crosses 0 dB. We find that when the magnitude plot crosses 0 dB, the phase angle is -144.8° . Therefore, the uncompensated system's phase margin is $-180^\circ + 144.8^\circ = 35.2^\circ$. The required phase margin based on the required damping ratio is $\Phi_M = \tan^{-1} \frac{2\zeta}{\sqrt{-2\zeta^2 + \sqrt{1 + 4\zeta^4}}} = 48.1^\circ$. Adding a 10° correction factor, the

required phase margin is 58.1° . Hence, the compensator must contribute $\phi_{\max} = 58.1^\circ - 35.2^\circ = 22.9^\circ$. Using $\phi_{\max} = \sin^{-1} \frac{1 - \beta}{1 + \beta}$, $\beta = \frac{1 - \sin \phi_{\max}}{1 + \sin \phi_{\max}} = 0.44$.

The compensator's peak magnitude is calculated as $M_{\max} = \frac{1}{\sqrt{\beta}} = 1.51$. Now find the frequency at which the uncompensated system has a magnitude $1/M_{\max}$, or -3.58 dB. From the Bode plot, this magnitude occurs at $\omega_{\max} = 50$ rad/s. The compensator's zero is at $z_c = \frac{1}{T}$. $\omega_{\max} = \frac{1}{T\sqrt{\beta}}$. Therefore, $z_c = 33.2$.

The compensator's pole is at $P_c = \frac{1}{\beta T} = \frac{z_c}{\beta} = 75.4$. The compensator gain is chosen to yield unity gain at dc.

Hence, $K_c = 75.4/33.2 = 2.27$. Summarizing, $G_c(s) = 2.27 \frac{(s + 33.2)}{(s + 75.4)}$, and

$$G(s) = \frac{300,000}{s(s + 50)(s + 120)}.$$

11.4

A 10% overshoot requires $\zeta = \frac{-\log\left(\frac{\%}{100}\right)}{\sqrt{\pi^2 + \log^2\left(\frac{\%}{100}\right)}} = 0.591$. The required bandwidth

is then calculated as $\omega_{BW} = \frac{\pi}{T_p \sqrt{1 - \zeta^2}} \sqrt{(1 - 2\zeta^2) + \sqrt{4\zeta^4 - 4\zeta^2 + 2}} = 7.53 \text{ rad/s}$.

In order to meet the steady-state error requirement of $K_v = 10 = \frac{K}{(8)(30)}$, we calculate $K = 2400$. The uncompensated Bode plot for this gain is shown below.

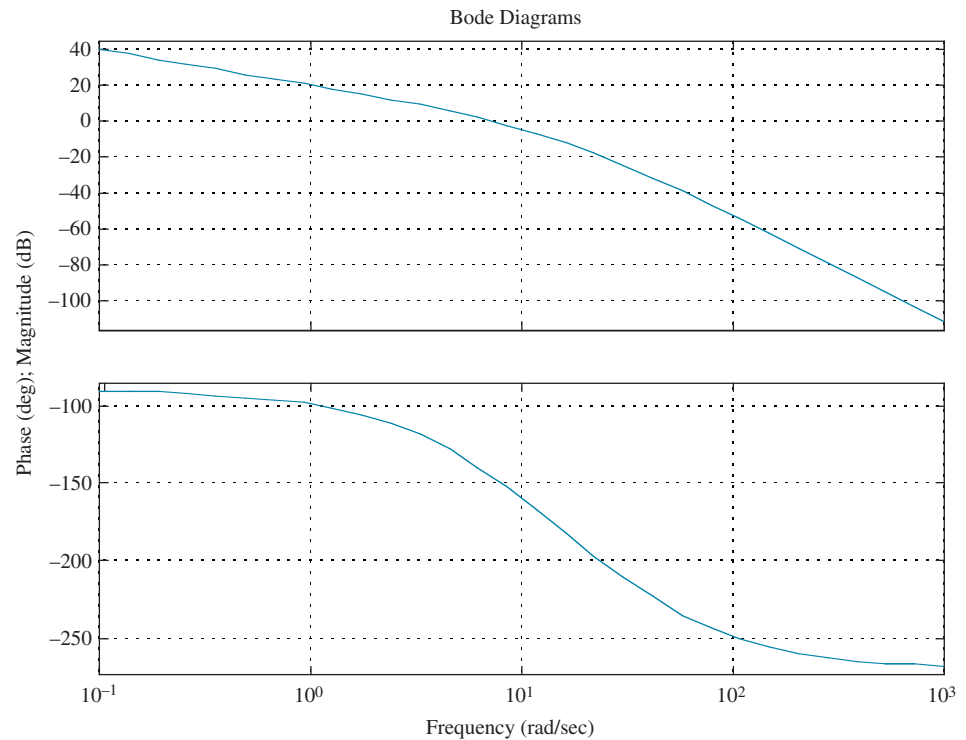

Let us select a new phase-margin frequency at $0.8\omega_{BW} = 6.02 \text{ rad/s}$. The required phase margin based on the required damping ratio is $\Phi_M = \tan^{-1} \frac{2\zeta}{\sqrt{-2\zeta^2 + \sqrt{1 + 4\zeta^4}}} = 58.6^\circ$. Adding a 5° correction factor, the required phase

margin is 63.6° . At 6.02 rad/s , the new phase-margin frequency, the phase angle is—which represents a phase margin of $180^\circ - 138.3^\circ = 41.7^\circ$. Thus, the lead compensator must contribute $\phi_{\max} = 63.6^\circ - 41.7^\circ = 21.9^\circ$.

$$\text{Using } \phi_{\max} = \sin^{-1} \frac{1 - \beta}{1 + \beta}, \beta = \frac{1 - \sin \phi_{\max}}{1 + \sin \phi_{\max}} = 0.456.$$

We now design the lag compensator by first choosing its higher break frequency one decade below the new phase-margin frequency, that is, $z_{lag} = 0.602 \text{ rad/s}$. The lag compensator's pole is $p_{lag} = \beta z_{lag} = 0.275$. Finally, the lag compensator's gain is $K_{lag} = \beta = 0.456$.

Now we design the lead compensator. The lead zero is the product of the new phase margin frequency and $\sqrt{\beta}$, or $z_{lead} = 0.8\omega_{BW}\sqrt{\beta} = 4.07$. Also, $p_{lead} = \frac{z_{lead}}{\beta} = 8.93$. Finally, $K_{lead} = \frac{1}{\beta} = 2.19$. Summarizing,

$$G_{lag}(s) = 0.456 \frac{(s + 0.602)}{(s + 0.275)}; G_{lead}(s) = 2.19 \frac{(s + 4.07)}{(s + 8.93)}; \text{ and } k = 2400.$$

CHAPTER 12

12.1

We first find the desired characteristic equation. A 5% overshoot requires

$$\zeta = \frac{-\log\left(\frac{\%}{100}\right)}{\sqrt{\pi^2 + \log^2\left(\frac{\%}{100}\right)}} = 0.69. \text{ Also, } \omega_n = \frac{\pi}{T_p \sqrt{1 - \zeta^2}} = 14.47 \text{ rad/s. Thus, the char-}$$

acteristic equation is $s^2 + 2\zeta\omega_n s + \omega_n^2 = s^2 + 19.97s + 209.4$. Adding a pole at -10 to cancel the zero at -10 yields the desired characteristic equation, $(s^2 + 19.97s + 209.4)(s + 10) = s^3 + 29.97s^2 + 409.1s + 2094$. The compensated system matrix in phase-variable form is

$$\mathbf{A} - \mathbf{BK} = \begin{bmatrix} 0 & 1 & 0 \\ 0 & 0 & 1 \\ -(k_1) & -(36 + k_2) & -(15 + k_3) \end{bmatrix}. \text{ The characteristic equation for this}$$

system is $|s\mathbf{I} - (\mathbf{A} - \mathbf{BK})| = s^3 + (15 + k_3)s^2 + (36 + k_2)s + (k_1)$. Equating coefficients of this equation with the coefficients of the desired characteristic equation yields the gains as

$$\mathbf{K} = [k_1 \quad k_2 \quad k_3] = [2094 \quad 373.1 \quad 14.97].$$

12.2

The controllability matrix is $\mathbf{C}_M = [\mathbf{B} \quad \mathbf{AB} \quad \mathbf{A}^2\mathbf{B}] = \begin{bmatrix} 2 & 1 & 1 \\ 1 & 4 & -9 \\ 1 & -1 & 16 \end{bmatrix}$. Since

$|\mathbf{C}_M| = 80$, \mathbf{C}_M is full rank, that is, rank 3. We conclude that the system is controllable.

12.3

First check controllability. The controllability matrix is $\mathbf{C}_{Mz} = [\mathbf{B} \quad \mathbf{AB} \quad \mathbf{A}^2\mathbf{B}] =$

$$\begin{bmatrix} 0 & 0 & 1 \\ 0 & 1 & -17 \\ 1 & -9 & 81 \end{bmatrix}. \text{ Since } |\mathbf{C}_{Mz}| = -1, \mathbf{C}_{Mz} \text{ is full rank, that is, rank 3. We conclude that}$$

the system is controllable. We now find the desired characteristic equation. A 20%

overshoot requires $\zeta = \frac{-\log\left(\frac{\%}{100}\right)}{\sqrt{\pi^2 + \log^2\left(\frac{\%}{100}\right)}} = 0.456$. Also, $\omega_n = \frac{4}{\zeta T_s} = 4.386 \text{ rad/s}$.

Thus, the characteristic equation is $s^2 + 2\zeta\omega_n s + \omega_n^2 = s^2 + 4s + 19.24$. Adding a pole at -6 to cancel the zero at -6 yields the resulting desired characteristic equation,

$$(s^2 + 4s + 19.24)(s + 6) = s^3 + 10s^2 + 43.24s + 115.45.$$

Since $G(s) = \frac{(s+6)}{(s+7)(s+8)(s+9)} = \frac{s+6}{s^3 + 24s^2 + 191s + 504}$, we can write the phase-

variable representation as $\mathbf{A}_p = \begin{bmatrix} 0 & 1 & 0 \\ 0 & 0 & 1 \\ -504 & -191 & -24 \end{bmatrix}$; $\mathbf{B}_p = \begin{bmatrix} 0 \\ 0 \\ 1 \end{bmatrix}$; $\mathbf{C}_p =$

$\begin{bmatrix} 6 & 1 & 0 \end{bmatrix}$. The compensated system matrix in phase-variable form is $\mathbf{A}_p - \mathbf{B}_p \mathbf{K}_p =$

$\begin{bmatrix} 0 & 1 & 0 \\ 0 & 0 & 1 \\ -(504+k_1) & -(191+k_2) & -(24+k_3) \end{bmatrix}$. The characteristic equation for this

system is $|s\mathbf{I} - (\mathbf{A}_p - \mathbf{B}_p \mathbf{K}_p)| = s^3 + (24+k_3)s^2 + (191+k_2)s + (504+k_1)$. Equating coefficients of this equation with the coefficients of the desired characteristic equation yields the gains as $\mathbf{K}_p = [k_1 \ k_2 \ k_3] = [-388.55 \ -147.76 \ -14]$. We now develop the transformation matrix to transform back to the z -system.

$$\mathbf{C}_{Mz} = \begin{bmatrix} \mathbf{B}_z & \mathbf{A}_z \mathbf{B}_z & \mathbf{A}_z^2 \mathbf{B}_z \end{bmatrix} = \begin{bmatrix} 0 & 0 & 1 \\ 0 & 1 & -17 \\ 1 & -9 & 81 \end{bmatrix} \text{ and}$$

$$\mathbf{C}_{Mp} = \begin{bmatrix} \mathbf{B}_p & \mathbf{A}_p \mathbf{B}_p & \mathbf{A}_p^2 \mathbf{B}_p \end{bmatrix} = \begin{bmatrix} 0 & 0 & 1 \\ 0 & 1 & -24 \\ 1 & -24 & 385 \end{bmatrix}.$$

Therefore,

$$\mathbf{P} = \mathbf{C}_{Mz} \mathbf{C}_{Mp}^{-1} = \begin{bmatrix} 0 & 0 & 1 \\ 0 & 1 & -17 \\ 1 & -9 & 81 \end{bmatrix} \begin{bmatrix} 191 & 24 & 1 \\ 24 & 1 & 0 \\ 1 & 0 & 0 \end{bmatrix} = \begin{bmatrix} 1 & 0 & 0 \\ 7 & 1 & 0 \\ 56 & 15 & 1 \end{bmatrix}$$

$$\text{Hence, } \mathbf{K}_z = \mathbf{K}_p \mathbf{P}^{-1} = \begin{bmatrix} -388.55 & -147.76 & -14 \end{bmatrix} \begin{bmatrix} 1 & 0 & 0 \\ -7 & 1 & 0 \\ 49 & -15 & 1 \end{bmatrix} \\ = \begin{bmatrix} -40.23 & 62.24 & -14 \end{bmatrix}.$$

12.4

For the given system $\mathbf{e}_x = (\mathbf{A} - \mathbf{LC})\mathbf{e}_x = \begin{bmatrix} -(24+l_1) & 1 & 0 \\ -(191+l_2) & 0 & 1 \\ -(504+l_3) & 0 & 0 \end{bmatrix} \mathbf{e}_x$. The characteristic

polynomial is given by $||s\mathbf{I} - (\mathbf{A} - \mathbf{LC})|| = s^3 + (24+l_1)s^2 + (191+l_2)s + (504+l_3)$. Now we find the desired characteristic equation. The dominant poles from Skill-Assessment Exercise 12.3 come from $(s^2 + 4s + 19.24)$. Factoring yields $(-2 + j3.9)$ and $(-2 - j3.9)$. Increasing these poles by a factor of 10 and adding a third pole 10 times the real part of the dominant second-order poles yields the

desired characteristic polynomial, $(s + 20 + j39)(s + 20 - j39)(s + 200) = s^3 + 240s^2 + 9921s + 384200$. Equating coefficients of the desired characteristic equation to the

system's characteristic equation yields $\mathbf{L} = \begin{bmatrix} 216 \\ 9730 \\ 383696 \end{bmatrix}$.

12.5

The observability matrix is $\mathbf{O}_M = \begin{bmatrix} \mathbf{C} \\ \mathbf{CA} \\ \mathbf{CA}^2 \end{bmatrix} = \begin{bmatrix} 4 & 6 & 8 \\ -64 & -80 & -78 \\ 674 & 848 & 814 \end{bmatrix}$, where

$\mathbf{A}^2 = \begin{bmatrix} 25 & 28 & 32 \\ -7 & -4 & -11 \\ 77 & 95 & 94 \end{bmatrix}$. The matrix is of full rank, that is, rank 3, since

$|\mathbf{O}_M| = -1576$. Therefore the system is observable.

12.6

The system is represented in cascade form by the following state and output equations:

$$\dot{\mathbf{z}} = \begin{bmatrix} -7 & 1 & 0 \\ 0 & -8 & 1 \\ 0 & 0 & -9 \end{bmatrix} \mathbf{z} + \begin{bmatrix} 0 \\ 0 \\ 1 \end{bmatrix} u$$

$$y = [1 \ 0 \ 0] \mathbf{z}$$

The observability matrix is $\mathbf{O}_{Mz} = \begin{bmatrix} \mathbf{C}_z \\ \mathbf{C}_z \mathbf{A}_z \\ \mathbf{C}_z \mathbf{A}_z^2 \end{bmatrix} = \begin{bmatrix} 1 & 0 & 0 \\ -7 & 1 & 0 \\ 49 & -15 & 1 \end{bmatrix}$,

where $\mathbf{A}_z^2 = \begin{bmatrix} 49 & -15 & 1 \\ 0 & 64 & -17 \\ 0 & 0 & 81 \end{bmatrix}$. Since $G(s) = \frac{1}{(s+7)(s+8)(s+9)}$

$= \frac{1}{s^3 + 24s^2 + 191s + 504}$, we can write the observable canonical form as

$$\dot{\mathbf{x}} = \begin{bmatrix} -24 & 1 & 0 \\ -191 & 0 & 1 \\ -504 & 0 & 0 \end{bmatrix} \mathbf{x} + \begin{bmatrix} 0 \\ 0 \\ 1 \end{bmatrix} u$$

$$y = [1 \ 0 \ 0] \mathbf{x}$$

The observability matrix for this form is $\mathbf{O}_{Mx} = \begin{bmatrix} \mathbf{C}_x \\ \mathbf{C}_x \mathbf{A}_x \\ \mathbf{C}_x \mathbf{A}_x^2 \end{bmatrix} = \begin{bmatrix} 1 & 0 & 0 \\ -24 & 1 & 0 \\ 385 & -24 & 1 \end{bmatrix}$,

where

$$\mathbf{A}_x^2 = \begin{bmatrix} 385 & -24 & 1 \\ 4080 & -191 & 0 \\ 12096 & 504 & 0 \end{bmatrix}.$$

We next find the desired characteristic equation. A 10% overshoot requires

$$\zeta = \frac{-\log\left(\frac{\%}{100}\right)}{\sqrt{\pi^2 + \log^2\left(\frac{\%}{100}\right)}} = 0.591. \text{ Also, } \omega_n = \frac{4}{\zeta T_s} = 67.66 \text{ rad/s. Thus, the characteristic}$$

equation is $s^2 + 2\zeta\omega_n s + \omega_n^2 = s^2 + 80s + 4578.42$. Adding a pole at -400 , or 10 times the real part of the dominant second-order poles, yields the resulting desired characteristic equation, $(s^2 + 80s + 4578.42)(s + 400) = s^3 + 480s^2 + 36580s + 1.831 \times 10^6$. For the system represented in observable canonical form $\mathbf{e}_x = (\mathbf{A}_x - \mathbf{L}_x \mathbf{C}_x) \mathbf{e}_x =$

$$\begin{bmatrix} -(24 + l_1) & 1 & 0 \\ -(191 + l_2) & 0 & 1 \\ -(504 + l_3) & 0 & 0 \end{bmatrix} \mathbf{e}_x. \text{ The characteristic polynomial is given by}$$

$||s\mathbf{I} - (\mathbf{A}_x - \mathbf{L}_x \mathbf{C}_x)|| = s^3 + (24 + l_1)s^2 + (191 + l_2)s + (504 + l_3)$. Equating coefficients of the desired characteristic equation to the system's characteristic equation

$$\text{yields } \mathbf{L}_x = \begin{bmatrix} 456 \\ 36,389 \\ 1,830,496 \end{bmatrix}.$$

Now, develop the transformation matrix between the observer canonical and cascade forms.

$$\begin{aligned} \mathbf{P} = \mathbf{O}_{Mz}^{-1} \mathbf{O}_{Mx} &= \begin{bmatrix} 1 & 0 & 0 \\ -7 & 1 & 0 \\ 49 & -15 & 1 \end{bmatrix}^{-1} \begin{bmatrix} 1 & 0 & 0 \\ -24 & 1 & 0 \\ 385 & -24 & 1 \end{bmatrix} \\ &= \begin{bmatrix} 1 & 0 & 0 \\ 7 & 1 & 0 \\ 56 & 15 & 1 \end{bmatrix} \begin{bmatrix} 1 & 0 & 0 \\ -24 & 1 & 0 \\ 385 & -24 & 1 \end{bmatrix} \\ &= \begin{bmatrix} 1 & 0 & 0 \\ -17 & 1 & 0 \\ 81 & -9 & 1 \end{bmatrix} \end{aligned}$$

Finally,

$$\mathbf{L}_z = \mathbf{P} \mathbf{L}_x = \begin{bmatrix} 1 & 0 & 0 \\ -17 & 1 & 0 \\ 81 & -9 & 1 \end{bmatrix} \begin{bmatrix} 456 \\ 36,389 \\ 1,830,496 \end{bmatrix} = \begin{bmatrix} 456 \\ 28,637 \\ 1,539,931 \end{bmatrix} \approx \begin{bmatrix} 456 \\ 28,640 \\ 1,540,000 \end{bmatrix}.$$

12.7

We first find the desired characteristic equation. A 10% overshoot requires

$$\zeta = \frac{-\log\left(\frac{\%}{100}\right)}{\sqrt{\pi^2 + \log^2\left(\frac{\%}{100}\right)}} = 0.591$$

Also, $\omega_n = \frac{\pi}{T_p\sqrt{1-\zeta^2}} = 1.948$ rad/s. Thus, the characteristic equation is $s^2 +$

$2\zeta\omega_n s + \omega_n^2 = s^2 + 2.3s + 3.79$. Adding a pole at -4 , which corresponds to the original system's zero location, yields the resulting desired characteristic equation, $(s^2 + 2.3s + 3.79)(s + 4) = s^3 + 6.3s^2 + 13s + 15.16$.

Now, $\begin{bmatrix} \dot{\mathbf{x}} \\ \dot{x}_N \end{bmatrix} = \begin{bmatrix} (\mathbf{A} - \mathbf{BK}) & \mathbf{BK}_e \\ -\mathbf{C} & 0 \end{bmatrix} \begin{bmatrix} \mathbf{x} \\ x_N \end{bmatrix} + \begin{bmatrix} \mathbf{0} \\ 1 \end{bmatrix} r$; and $y = [\mathbf{C} \ 0] \begin{bmatrix} \mathbf{x} \\ x_N \end{bmatrix}$,

where

$$\mathbf{A} - \mathbf{BK} = \begin{bmatrix} 0 & 1 \\ -7 & -9 \end{bmatrix} - \begin{bmatrix} 0 \\ 1 \end{bmatrix} [k_1 \ k_2] = \begin{bmatrix} 0 & 1 \\ -7 & -9 \end{bmatrix} - \begin{bmatrix} 0 & 0 \\ k_1 & k_2 \end{bmatrix}$$

$$= \begin{bmatrix} 0 & 1 \\ -(7+k_1) & -(9+k_2) \end{bmatrix}$$

$$\mathbf{C} = [4 \ 1]$$

$$\mathbf{BK}_e = \begin{bmatrix} 0 \\ 1 \end{bmatrix} k_e = \begin{bmatrix} 0 \\ k_e \end{bmatrix}$$

Thus,

$$\begin{bmatrix} \dot{x}_1 \\ \dot{x}_2 \\ \dot{x}_N \end{bmatrix} = \begin{bmatrix} 0 & 1 & 0 \\ -(7+k_1) & -(9+k_2) & k_e \\ -4 & -1 & 0 \end{bmatrix} \begin{bmatrix} x_1 \\ x_2 \\ x_N \end{bmatrix} + \begin{bmatrix} \mathbf{0} \\ 1 \end{bmatrix} r; \quad y = [4 \ 1 \ 0] \begin{bmatrix} x_1 \\ x_2 \\ x_N \end{bmatrix}.$$

Finding the characteristic equation of this system yields

$$\left| s\mathbf{I} - \begin{bmatrix} (\mathbf{A} - \mathbf{BK}) & \mathbf{BK}_e \\ -\mathbf{C} & 0 \end{bmatrix} \right| = \left| \begin{bmatrix} s & 0 & 0 \\ 0 & s & 0 \\ 0 & 0 & s \end{bmatrix} - \begin{bmatrix} 0 & 1 & 0 \\ -(7+k_1) & -(9+k_2) & k_e \\ -4 & -1 & 0 \end{bmatrix} \right|$$

$$= \left| \begin{bmatrix} s & -1 & 0 \\ (7+k_1) & s+(9+k_2) & -k_e \\ 4 & 1 & s \end{bmatrix} \right| = s^3 + (9+k_2)s^2 + (7+k_1+k_e)s + 4k_e$$

Equating this polynomial to the desired characteristic equation,

$$s^3 + 6.3s^2 + 13s + 15.16 = s^3 + (9+k_2)s^2 + (7+k_1+k_e)s + 4k_e$$

Solving for the k 's,

$$\mathbf{K} = [2.21 \ -2.7] \text{ and } k_e = 3.79.$$

CHAPTER 13

13.1

$$f(t) = \sin(\omega kT); f^*(t) = \sum_{k=0}^{\infty} \sin(\omega kT) \delta(t - kT);$$

$$\begin{aligned} F^*(s) &= \sum_{k=0}^{\infty} \sin(\omega kT) e^{-kTs} = \sum_{k=0}^{\infty} \frac{(e^{j\omega kT} - e^{-j\omega kT}) e^{-kTs}}{2j} \\ &= \frac{1}{2j} \sum_{k=0}^{\infty} \left(e^{T(s-j\omega)} \right)^{-k} - \left(e^{T(s+j\omega)} \right)^{-k} \end{aligned}$$

$$\text{But, } \sum_{k=0}^{\infty} x^{-k} = \frac{1}{1-x^{-1}}$$

Thus,

$$\begin{aligned} F^*(s) &= \frac{1}{2j} \left[\frac{1}{1 - e^{-T(s-j\omega)}} - \frac{1}{1 - e^{-T(s+j\omega)}} \right] = \frac{1}{2j} \left[\frac{e^{-Ts} e^{j\omega T} - e^{-Ts} e^{j\omega T}}{1 - (e^{-Ts} e^{j\omega T} - e^{-Ts} e^{j\omega T}) + e^{-2Ts}} \right] \\ &= e^{-Ts} \left[\frac{\sin(\omega T)}{1 - e^{-Ts} 2\cos(\omega T) + e^{-2Ts}} \right] = \frac{z^{-1} \sin(\omega T)}{1 - 2z^{-1} \cos(\omega T) + z^{-2}} \end{aligned}$$

13.2

$$F(z) = \frac{z(z+1)(z+2)}{(z-0.5)(z-0.7)(z-0.9)}$$

$$\frac{F(z)}{z} = \frac{z(z+1)(z+2)}{(z-0.5)(z-0.7)(z-0.9)}$$

$$= 46.875 \frac{z}{z-0.5} - 114.75 \frac{1}{z-0.7} + 68.875 \frac{z}{z-0.9}$$

$$F(z) = 46.875 \frac{z}{z-0.5} - 114.75 \frac{z}{z-0.7} + 68.875 \frac{z}{z-0.9},$$

$$f(kT) = 46.875(0.5)^k - 114.75(0.7)^k + 68.875(0.9)^k$$

13.3

$$\text{Since } G(s) = (1 - e^{-Ts}) \frac{8}{s(s+4)},$$

$$G(z) = (1 - z^{-1}) z \left\{ \frac{8}{s(s+4)} \right\} = \frac{z-1}{z} z \left\{ \frac{A}{s} + \frac{B}{s+4} \right\} = \frac{z-1}{z} z \left\{ \frac{2}{s} + \frac{2}{s+4} \right\}.$$

$$\text{Let } G_2(s) = \frac{2}{s} + \frac{2}{s+4}. \text{ Therefore, } g_2(t) = 2 - 2e^{-4t}, \text{ or } g_2(kT) = 2 - 2e^{-4kT}.$$

$$\text{Hence, } G_2(z) = \frac{2z}{z-1} - \frac{2z}{z - e^{-4T}} = \frac{2z(1 - e^{-4T})}{(z-1)(z - e^{-4T})}.$$

$$\text{Therefore, } G(z) = \frac{z-1}{z} G_2(z) = \frac{2(1-e^{-4T})}{(z-e^{-4T})}.$$

$$\text{For } T = \frac{1}{4} \text{ s, } G(z) = \frac{1.264}{z-0.3679}.$$

13.4

Add phantom samplers to the input, feedback after $H(s)$, and to the output. Push $G_1(s)G_2(s)$, along with its input sampler, to the right past the pickoff point and obtain the block diagram shown below.

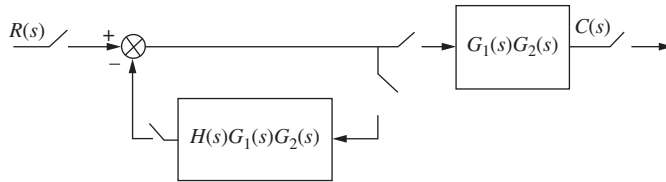

$$\text{Hence, } T(z) = \frac{G_1 G_2(z)}{1 + H G_1 G_2(z)}.$$

13.5

Let $G(s) = \frac{20}{s+5}$. Let $G_2(s) = \frac{G(s)}{s} = \frac{20}{s(s+5)} = \frac{4}{s} - \frac{4}{s+5}$. Taking the inverse Laplace transform and letting $t = kT$, $g_2(kT) = 4 - 4e^{-5kT}$. Taking the z-transform yields $G_2(z) = \frac{4z}{z-1} - \frac{4z}{z-e^{-5T}} = \frac{4z(1-e^{-5T})}{(z-1)(z-e^{-5T})}$.

$$\text{Now, } G(z) = \frac{z-1}{z} G_2(z) = \frac{4(1-e^{-5T})}{(z-e^{-5T})}.$$

$$\text{Finally, } T(z) = \frac{G(z)}{1+G(z)} = \frac{4(1-e^{-5T})}{z-5e^{-5T}+4}.$$

The pole of the closed-loop system is at $5e^{-5T} - 4$. Substituting values of T , we find that the pole is greater than 1 if $T > 0.1022$ s. Hence, the system is stable for $0 < T < 0.1022$ s.

13.6

Substituting $z = \frac{s+1}{s-1}$ into $D(z) = z^3 - z^2 - 0.5z + 0.3$, we obtain $D(s) = s^3 - 8s^2 - 27s - 6$. The Routh table for this polynomial is shown below.

s^3	1	-27
s^2	-8	-6
s^1	-27.75	0
s^0	-6	0

Since there is one sign change, we conclude that the system has one pole outside the unit circle and two poles inside the unit circle. The table did not produce a row of zeros and thus, there are no $j\omega$ poles. The system is unstable because of the pole outside the unit circle.

13.7

Defining $G(s)$ as $G_1(s)$ in cascade with a zero-order-hold,

$$G(s) = 20(1 - e^{-Ts}) \left[\frac{(s+3)}{s(s+4)(s+5)} \right] = 20(1 - e^{-Ts}) \left[\frac{3/20}{s} + \frac{1/4}{(s+4)} - \frac{2/5}{(s+5)} \right].$$

Taking the z -transform yields

$$G(z) = 20(1 - z^{-1}) \left[\frac{(3/20)z}{z-1} + \frac{(1/4)z}{z - e^{-4T}} - \frac{(2/5)z}{z - e^{-5T}} \right] = 3 + \frac{5(z-1)}{z - e^{-4T}} - \frac{8(z-1)}{z - e^{-5T}}.$$

Hence for $T = 0.1$ second, $K_p = \lim_{z \rightarrow 1} G(z) = 3$, and $K_v = \frac{1}{T} \lim_{z \rightarrow 1} (z-1)G(z) = 0$, and $K_a = \frac{1}{T^2} \lim_{z \rightarrow 1} (z-1)^2 G(z) = 0$. Checking for stability, we find that the system is stable for $T = 0.1$ second, since $T(z) = \frac{G(z)}{1+G(z)} = \frac{1.5z - 1.109}{z^2 + 0.222z - 0.703}$ has poles inside the unit circle at -0.957 and $+0.735$. Again, checking for stability, we find that the system is unstable for $T = 0.5$ second, since $T(z) = \frac{G(z)}{1+G(z)} = \frac{3.02z - 0.6383}{z^2 + 2.802z - 0.6272}$ has poles inside and outside the unit circle at $+0.208$ and -3.01 , respectively.

13.8

Draw the root locus superimposed over the $\zeta = 0.5$ curve shown below. Searching along a 54.3° line, which intersects the root locus and the $\zeta = 0.5$ curve, we find the point $0.587 \angle 54.3^\circ = (0.348 + j0.468)$ and $K = 0.31$.

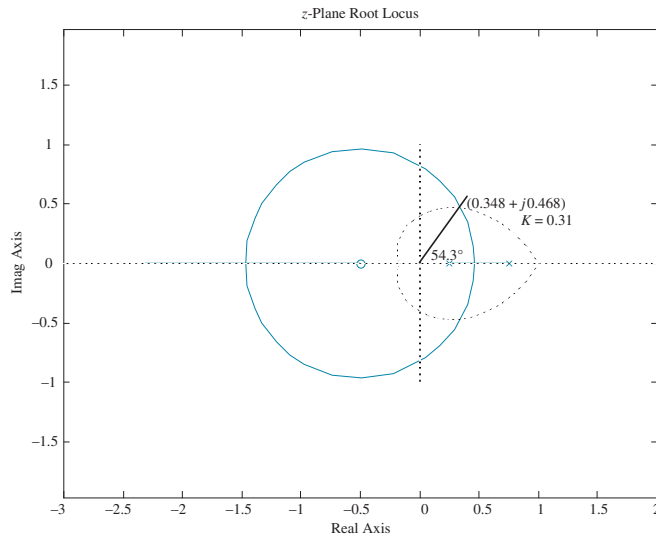
**13.9**

Let

$$G_c(s) = G(s)G_c(s) = \frac{100K}{s(s+36)(s+100)} \frac{2.38(s+25.3)}{(s+60.2)} = \frac{342720(s+25.3)}{s(s+36)(s+100)(s+60.2)}.$$

The following shows the frequency response of $G_e(j\omega)$.

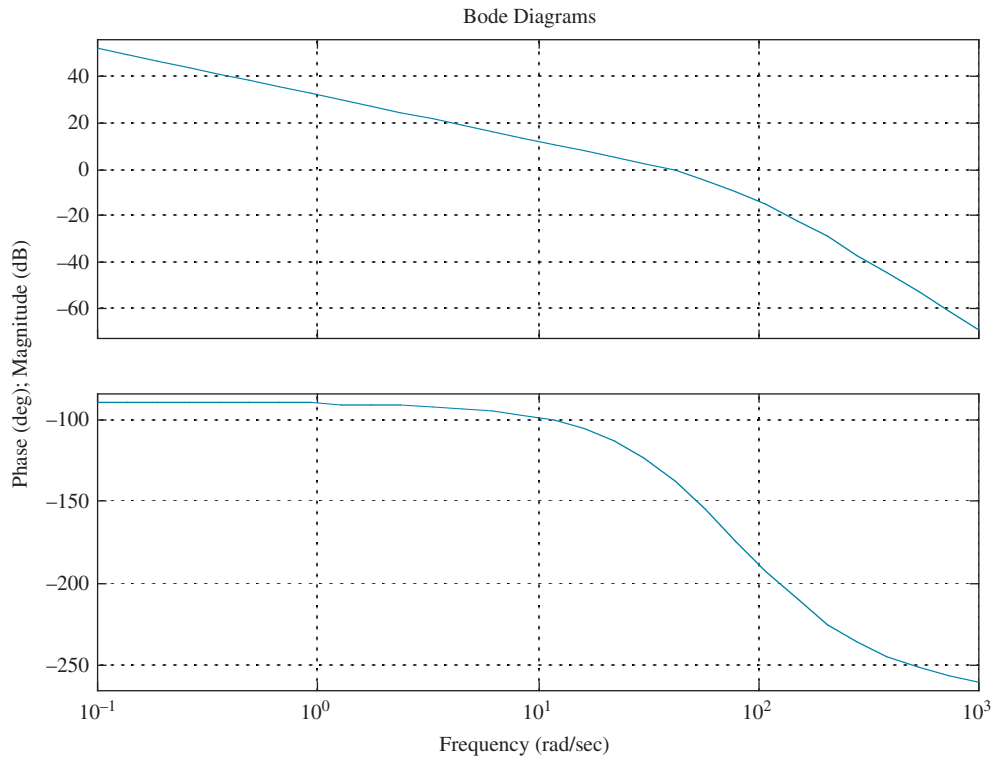

We find that the zero dB frequency, ω_{Φ_M} , for $G_e(j\omega)$ is 39 rad/s. Using Astrom's guideline the value of T should be in the range, $0.15/\omega_{\Phi_M} = 0.0038$ second to $0.5/\omega_{\Phi_M} = 0.0128$ second. Let us use $T = 0.001$ second. Now find the Tustin transformation for the compensator. Substituting $s = \frac{2(z-1)}{T(z+1)}$ into $G_c(s) = \frac{2.38(s+25.3)}{(s+60.2)}$ with $T = 0.001$ second yields

$$G_c(z) = 2.34 \frac{(z - 0.975)}{(z - 0.9416)}.$$

13.10

$G_c(z) = \frac{X(z)}{E(z)} = \frac{1899z^2 - 3761z + 1861}{z^2 - 1.908z + 0.9075}$. Cross-multiply and obtain $(z^2 - 1.908z + 0.9075)X(z) = (1899z^2 - 3761z + 1861)E(z)$. Solve for the highest power of z operating on the output, $X(z)$, and obtain $z^2X(z) = (1899z^2 - 3761z + 1861)E(z) - (-1.908z + 0.9075)X(z)$. Solving for $X(z)$ on the left-hand side yields

$X(z) = (1899 - 3761z^{-1} + 1861z^{-2}) E(z) - (-1.908z^{-1} + 0.9075z^{-2}) X(z)$. Finally, we implement this last equation with the following flow chart:

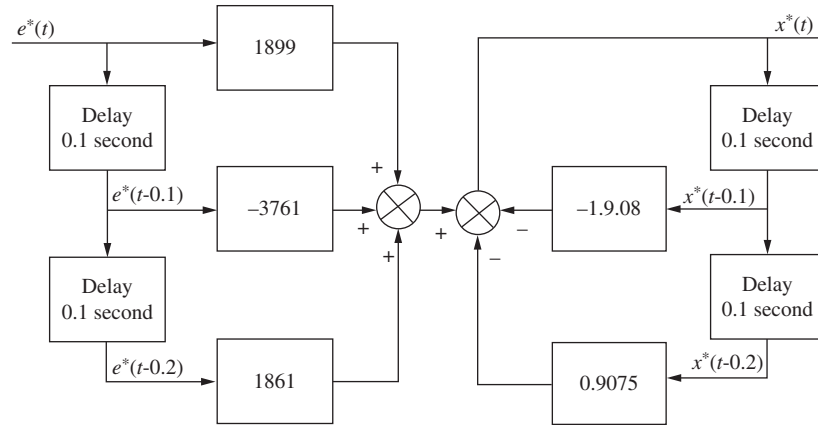

Copyright © 2011 by John Wiley & Sons, Inc.

Founded in 1807, John Wiley & Sons, Inc. has been a valued source of knowledge and understanding for more than 200 years, helping people around the world meet their needs and fulfill their aspirations. Our company is built on a foundation of principles that include responsibility to the communities we serve and where we live and work. In 2008, we launched a Corporate Citizenship Initiative, a global effort to address the environmental, social, economic, and ethical challenges we face in our business. Among the issues we are addressing are carbon impact, paper specifications and procurement, ethical conduct within our business and among our vendors, and community and charitable support. For more information, please visit our website: www.wiley.com/go/citizenship.

No part of this publication may be reproduced, stored in a retrieval system or transmitted in any form or by any means, electronic, mechanical, photocopying, recording, scanning or otherwise, except as permitted under Sections 107 or 108 of the 1976 United States Copyright Act, without either the prior written permission of the Publisher or authorization through payment of the appropriate per-copy fee to the Copyright Clearance Center, 222 Rosewood Drive, Danvers, MA 01923, (978) 750-8400, fax (978) 646-8600. Requests to the Publisher for permission should be addressed to the Permissions Department, John Wiley & Sons, Inc., 111 River Street, Hoboken, NJ 07030-5774, (201) 748-6011, fax (201) 748-6008 or online at <http://www.wiley.com/go/permissions>.

Evaluation copies are provided to qualified academics and professionals for review purposes only, for use in their courses during the next academic year. These copies are licensed and may not be sold or transferred to a third party. Upon completion of the review period, please return the evaluation copy to Wiley. Return instructions and a free of charge return shipping label are available at www.wiley.com/go/returnlabel. Outside of the United States, please contact your local representative.

ISBN 13 978-0470-54756-4

Printed in the United States of America.

10 9 8 7 6 5 4 3 2 1

