

Fall  
2017

# Power Electronics

## EE 3305 LECTURE NOTES

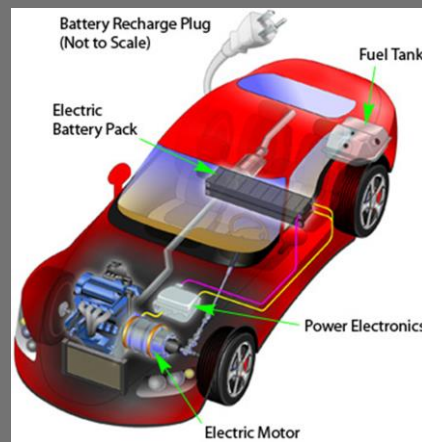

*Dr. M. Abu-Khaizaran*

Electrical and Computer Engineering Department- BZU



Dr. M. Abu-Khaizaran, BZU, Fall 2017

---

# Table of Contents

---

|   |            |
|---|------------|
| <i>Part I: Power Electronic Devices.....</i>                          | <i>5</i>   |
| <i>Part II: Uncontrolled AC-to-DC Converters: Rectifiers .....</i>    | <i>53</i>  |
| <i>Part III: AC-to-DC Converters (Controlled Rectifiers).....</i>     | <i>97</i>  |
| <i>Part IV: AC Voltage Controllers .....</i>                          | <i>131</i> |
| <i>Part V: DC-to-DC Converters (DC Choppers).....</i>                 | <i>149</i> |
| <i>Part VI: DC-to-AC Converters (Power Electronic Inverters).....</i> | <i>177</i> |
| <i>References.....</i>  | <i>215</i> |

Dr. M. Abu-Khaizaran, BZU, Fall 2017



---

# Part I: Power Electronic Devices

---

**Power Electronics:** application of solid state electronics for the control and conversion of electric power by supplying voltages and currents in a form that is optimally suited for user loads.

## A Block Diagram of a Power Electronic System

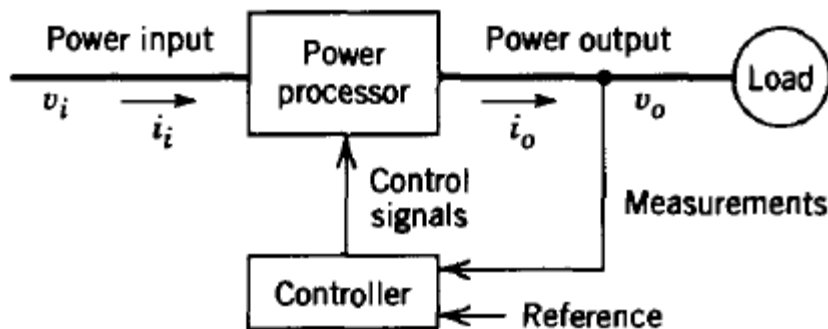

The main components are:

**Power Processor:** It is a power conditioning circuit (a converter). It consists of passive elements and devices (active switches).

**Controller:** Integrated circuits (analog/digital signal processors)

**Load:** Static → residential lighting, heaters, power supplies

Dynamic (Rotating) → motors and machines in general

## Applications

Typical applications of Power Electronics are:

1. Switch Mode (DC) Power Supplies and Uninterruptible Power Supplies (UPS). They are used for computer, communication equipment and consumer electronics which need regulated and uninterruptible DC power supplies.

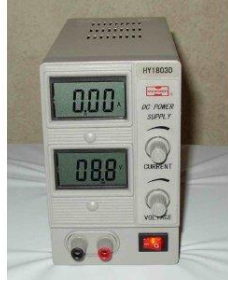

2. Energy Conversion: for motor drives (adjustable speed) by controlling the voltage and/or frequency



3. Process Control and Factory Automation → Robots and Factories



4. Transportation: Electric trains and electric vehicles



5. Electro-Technical Applications: Welding, Electroplating and Induction Heating



6. Utility-Related Applications: transmission of power over High Voltage DC (HVDC), interconnection of PhotoVoltaic (PV) and Wind electric system with utility grid

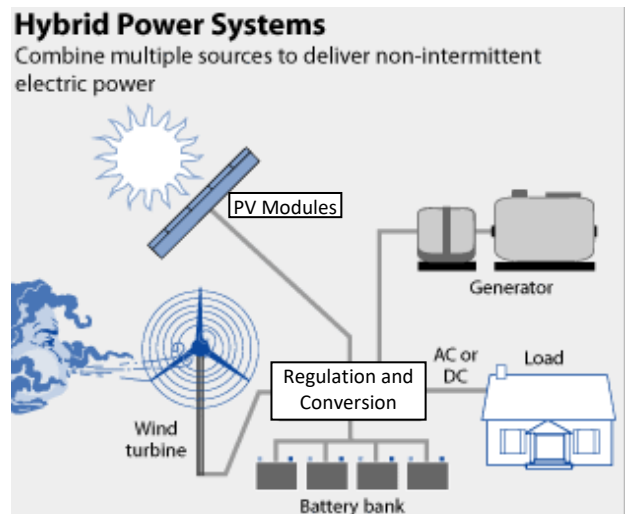
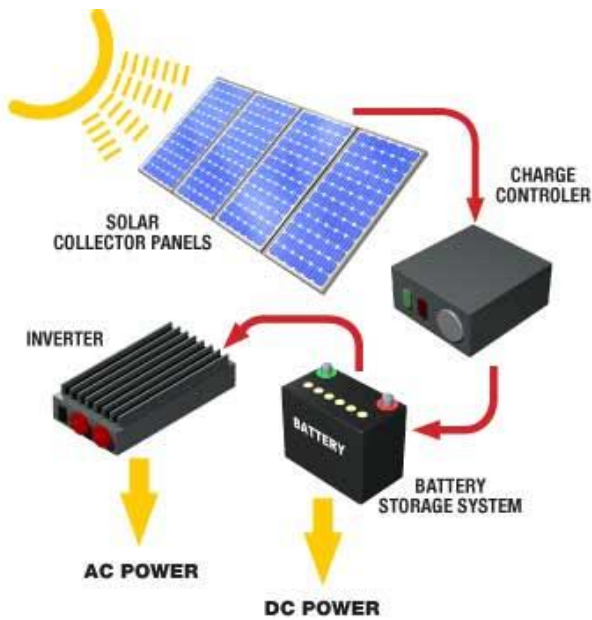
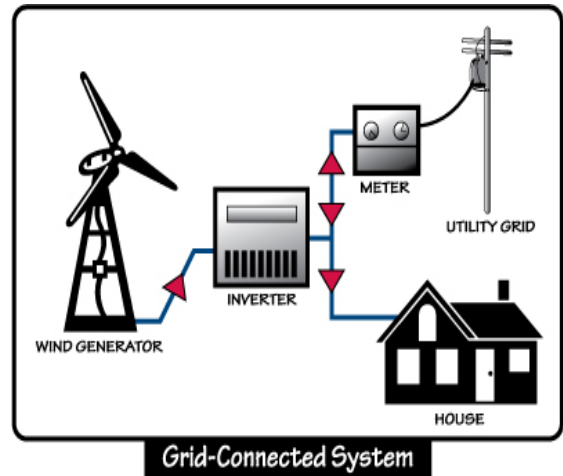
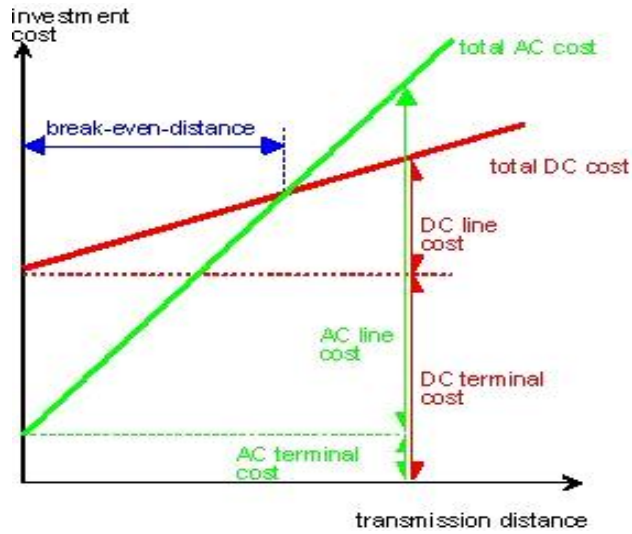

# Basic Semiconductor Physics

## Semiconductors

A single crystal of a semiconductor (Silicon), which has four valence electrons (Group Four of the Periodic Table of Elements shown next page), is composed of a 3D regular array of Silicon atoms. Each atom is bonded to four nearest neighbors by covalent bonds composed of electrons shared between the two adjacent atoms. A two-dimensional array of Silicon atoms is shown in the Figure below.

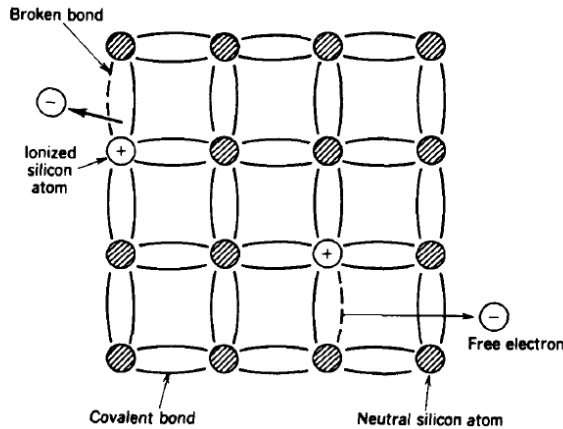

- At temperatures above absolute zero, some bonds are broken in process called **Thermal Ionization**, which creates a free electron and leaves behind a positive charge (a hole).
- Thermal Ionization generates an equal number of electrons and holes.

## Doped Semiconductors

**Doping Process:** is the addition of an impurity material to the semiconductor to change the thermal equilibrium density of electrons and holes (change its resistance)

**n-type:** the impurity material is an element from column V of the Periodic Table, such as Phosphorus (P), which has five valence electrons (it will be named a donor). The electrons are majority carriers and holes are minority carries in an n-type material.

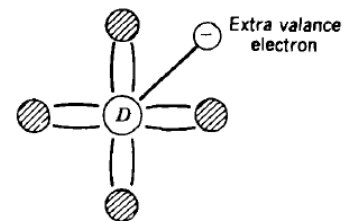

**p-type:** the impurity material is an element from column III of the Periodic Table, such as Boron (B), which has three valence electrons (it is named an acceptor). The holes are majority carriers and electrons are minority carriers in a p-type material.

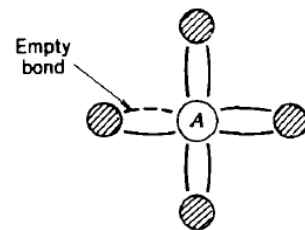





## pn-Junction

- ◆ p-type and n-type doped semiconductors are used to form the pn-junction which forms the basic structure of many power electronic devices.
- ◆ A pn-junction is formed when an n-type region in a Silicon crystal is adjacent to a p-type region in the same crystal. Such an abrupt junction can be formed by diffusing acceptor impurities into an n-type Silicon crystal (or diffusing donors into a p-type Silicon crystal).
- ◆ Once the pn-junction is formed, the majority carriers diffuse from either side of the junction and cross the junction to the other side, leaving behind ionized atoms. Hence, forming a depleted layer (space charge) free of charge carriers, as illustrated in the Figure below.

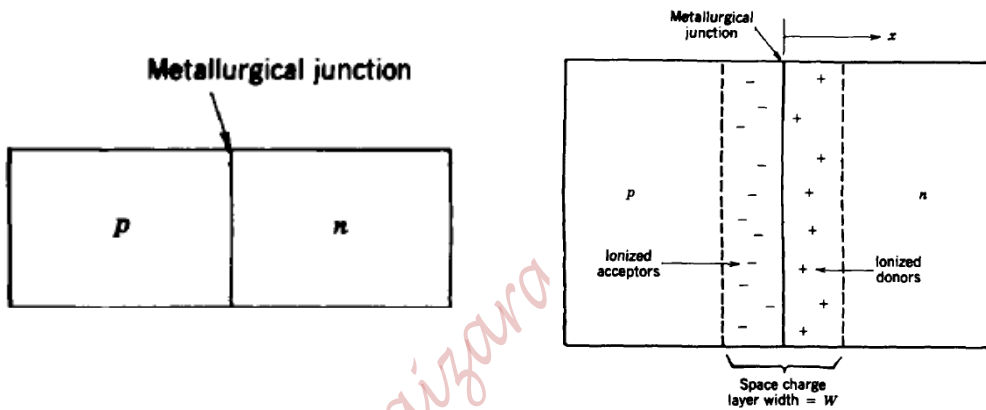

- ◆ For a pn-junction to be able to block current and support a voltage two conditions must be satisfied:
  1. There should be a lightly doped region at least at one side of the junction.
  2. There should be a wide region to accommodate the depletion layer, which widens as the applied reverse voltage increases, as illustrated in the Figure below.

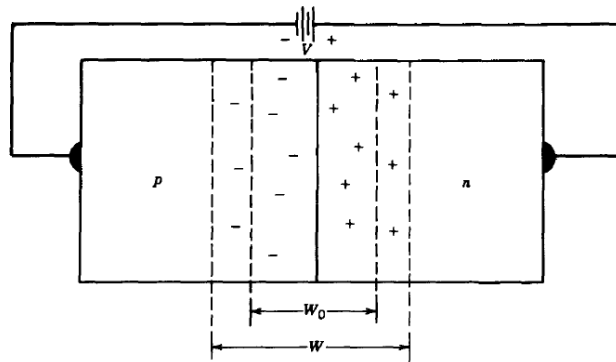

## Power Semiconductor Devices

According to their degree of controllability, power devices can be classified into three groups:

1. **Power Diodes:** On and off states are controlled by the power circuit.
2. **Thyristors:** They can be latched on by the control signal, but must be turned off by the power circuit.
3. **Controllable Switches:** turn-on and turn-off are achieved by the control signal.

The latter category includes:

Gate Turn-Off (GTOs) Thyristors, Integrated Gate Commutated Thyristors (IGCTs), Bipolar Junction Transistors (BJTs), Metal–Oxide–Semiconductor-Field-Effect-Transistors (MOSFETs), Insulated Gate Bipolar Transistors (IGBTs), MOS–Controlled Thyristors (MCTs),...

### Power Diodes:

- Samples of Power Diodes are shown in the Figures below.



- The layers' structure of a Power Diode is shown in the Figure below.

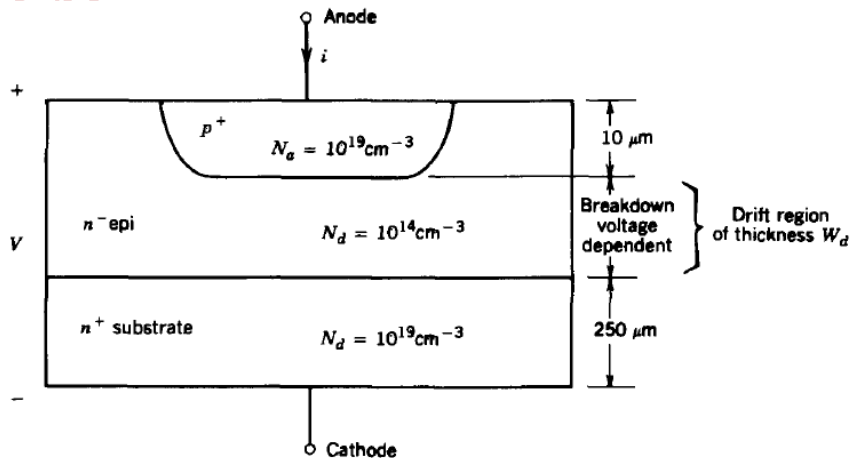



- It has a lightly doped n-layer ( $n^-$ ) called a drift region or epitaxial layer. This layer accommodates the depletion layer during the blocking state.
- They are minority carrier devices; the current conduction is dependent on both types of carriers (holes and electrons).
- The effect of  $n^+$  is to reduce the resistivity of  $n^-$  during conduction.
- The symbol of a Power Diode is shown in the Figure below. It has two terminals; Anode (A) and Cathode (K).

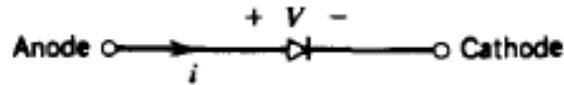

- The current-voltage (i-v) characteristic of a power Diode is shown in the Figure below.

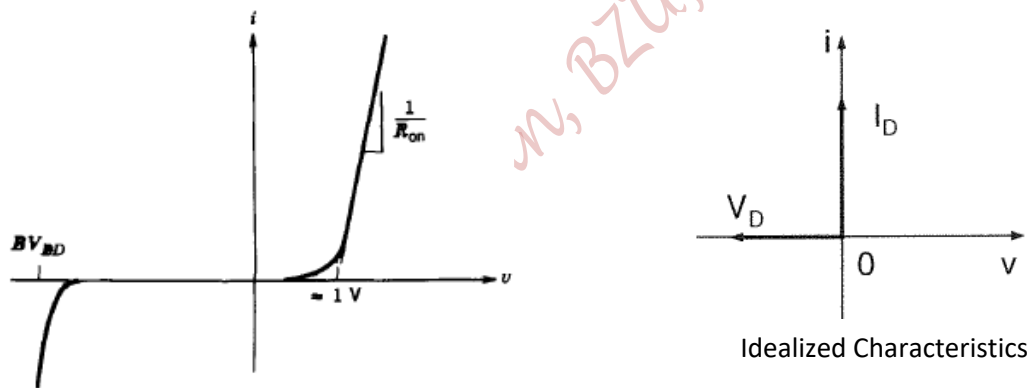

- A Power Diode begins conduction, when a small forward voltage is applied across it, which is in the order of 1V (i.e.  $V_A > V_K$ ).
- The voltage drop across the Diode during conduction is:

$$V_F = V_j + IR_{on}$$

where  $V_j$  is the voltage drop across the pn-junction ( $\sim 0.65V$  to  $0.7V$  for Silicon), and  $R_{on}$  represents the resistance of the current path in the Diode layers.

- When reverse biased, a negligibly small current flows in the reverse direction as long as the voltage is less than the rated breakdown voltage in normal operation.
- The reverse bias voltage should not reach the Breakdown Voltage ( $BV_{BD}$ ). Otherwise, a destructive current flows in the reverse direction; from Cathode to Anode.

## Diode Switching:

The current and voltage waveforms during a power Diode's switching are shown in the Figure below.

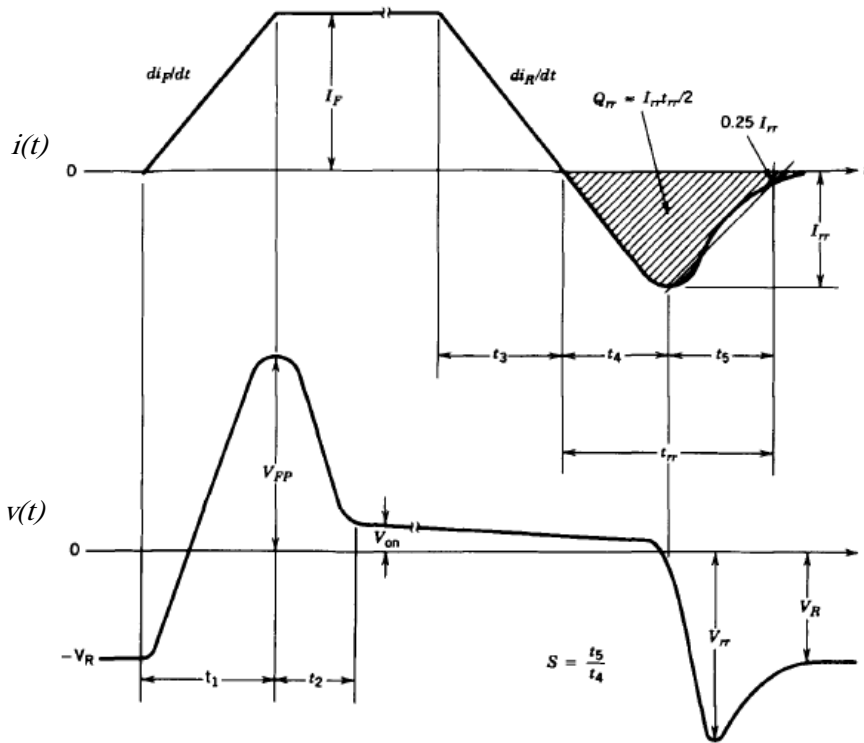

### Turn-on:

It turns on fast. However, a forward recovery time ( $t_{rf} = t_1 + t_2$ ) is needed before the entire area of the junction becomes conductive and  $di/dt$  must be kept low to meet the turn-on time limit (minimum  $t_{rf}$ ).

### Turn-off:

At turn-off, the Diode current reverses for a reverse recovery time ( $t_{rr} = t_4 + t_5$ ) before falling to zero and blocking a negative voltage. This time is needed to remove excess carriers in the diode.

In the above Figure,  $Q_{rr}$ : is the reverse recovery charge.

$t_{rr}$ : is the reverse recovery time; it is the time needed to get rid of the excess carriers (or reverse recovery charge), and  $t_{rr} = t_4 + t_5$

$I_{rr}$ : is the reverse recovery peak current

**Note:** At turn-off, the overshoot in the Diode's voltage is due to the voltage induced across the stray inductance in the circuit ( $L_s \frac{di}{dt} = V_{rr} - V_R$ ). Also, at turn-on this overshoot ( $V_{FP} - V_{on}$ ) is attributed, besides the voltage induced in the stray inductance, to the high resistivity of the drift region before being **conductivity modulated**.

### Softness Factor:

$$S = \frac{t_5}{t_4} \quad \text{or} \quad S = \frac{t_b}{t_a}$$

It should be greater than '1' for Soft Recovery Diodes, otherwise the diode will be Snappy, and oscillations will be encountered in the diode voltage and current as seen in the Figure next.

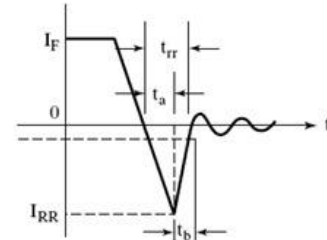

### Types of Power Diodes:

1. **General Purpose Diodes (Line Frequency Diodes):** the on-state voltage is minimized and as a consequence,  $t_{rr}$  is larger than that for Fast Recovery Diodes. Power ratings: several kilo Amps and several kilo Volts.

2. **Fast Recovery Diodes:** their recovery time is less than few microseconds ( $t_{rr} < 5\mu s$ ), their power ratings are in the range of several kilo Volts and several hundreds of Amps.

Note that the first and second types are manufactured based on a compromise between the switching speed (frequency and  $t_{rr}$ ) and the on-state voltage drop ( $V_{on}$ ); i.e. power ratings. This compromise is achieved by Life Time Control of Carriers and creation of Recombination Centers using gold doping or electron irradiation. Bearing in mind, that the Breakdown voltage is inversely proportional to the doping level.

3. **Schottky Diodes:** These Diodes have a metal replacing the p-type and forming an abrupt junction between the metal and the n-type, as shown in the Figure next. They are majority carrier devices; the current flow depends on electrons only. Since there is no stored minority carriers that have to be removed at turn-off, Schottky Diodes are fast switching Diodes and  $t_{rr}$  is in nanoseconds. They have a

**low forward voltage drop** ( $\sim 0.3V-0.4V$ ), but they have **limited voltage blocking capabilities** (100-200V) and high leakage currents. Their current rating is up to 300A.

**Note:** guard ring structure is used for improving the Breakdown voltage capability.

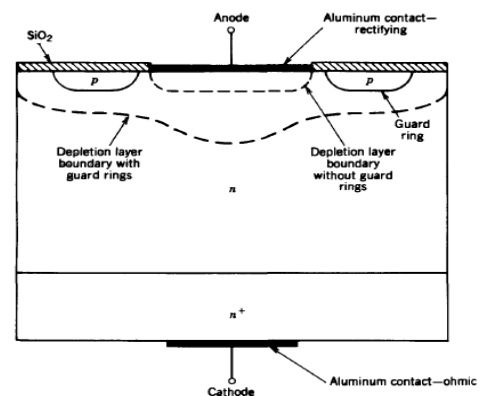

## Thyristors: Semiconductor (Silicon) Controlled Rectifiers (SCRs)

- Samples of Thyristors are shown in the Figure below.



- They are minority carrier devices.
- They have four-layer structure as shown in the Figure below.

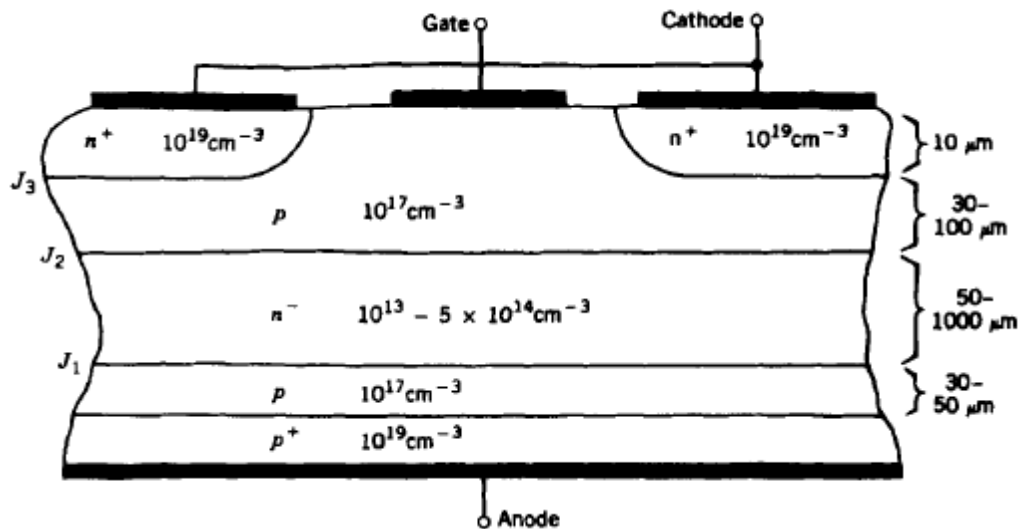

- An SCR has 3 pn-junctions;  $j_1$  is responsible for supporting a reverse voltage (reverse blocking) and  $j_2$ , with no gate current, is responsible for supporting a forward voltage (forward blocking). Hence, if no gate current is applied, an SCR blocks current in either direction. In general, the voltage blocking capability of an SCR is equal for either polarities.
- The simplified layers' structure of an SCR, shown on the next page, comprises (is equivalent to) two Power Bipolar Junction Transistors (Power BJTs); one pnp ( $(p_1^+ p_1) n_1^- p_2$ ) and the other is npn-type ( $n_1^- p_2 n_2^+$ ). The bases and collectors of these transistors are connected together as shown next page.

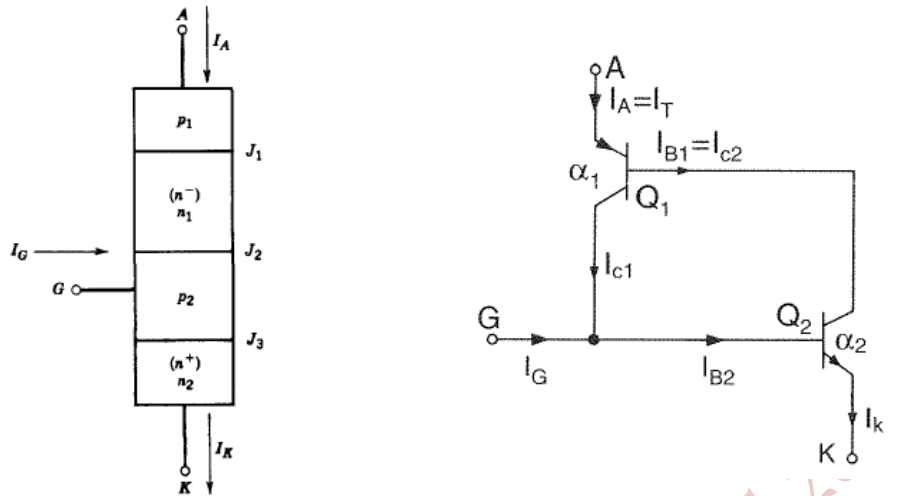

- It can be proved that the Anode current ( $I_A$ ) is related to the Gate current ( $I_G$ ) and the current gains of the two transistors by:

$$I_A = \frac{\alpha_2 I_G + I_{CO1} + I_{CO2}}{1 - (\alpha_1 + \alpha_2)}$$

where  $\alpha_1$  and  $\alpha_2$  are the emitter-to-collector current gains for transistors  $Q_1$  and  $Q_2$ , respectively.  $I_{CO}$  is the reverse saturation current across the collector junction.

At low currents, the sum of  $\alpha_1$  and  $\alpha_2$  is less than unity, hence a low current flows (in the range of micro Amperes for low current devices to few hundred milli Amperes in very high current devices).

If  $\alpha_1 + \alpha_2$  approaches unity ( $\alpha_1$  and  $\alpha_2$  increase due to the decrease in the transistors' effective bases when a large forward voltage is applied or a gate current is injected) abruptly a large Anode current flows, which is limited by the external circuit. In other words, two weak transistors (of low  $\alpha$ 's) produce a very high current carrying capability device; the Thyristor.

- The symbol of an SCR is shown next. It has 3 terminals: an Anode (A), a Cathode (K) and a Gate (G).

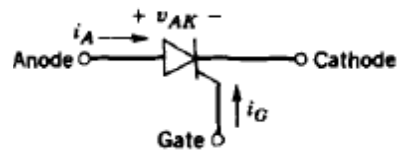

➡ The i-v characteristic of the Thyristor is shown below.

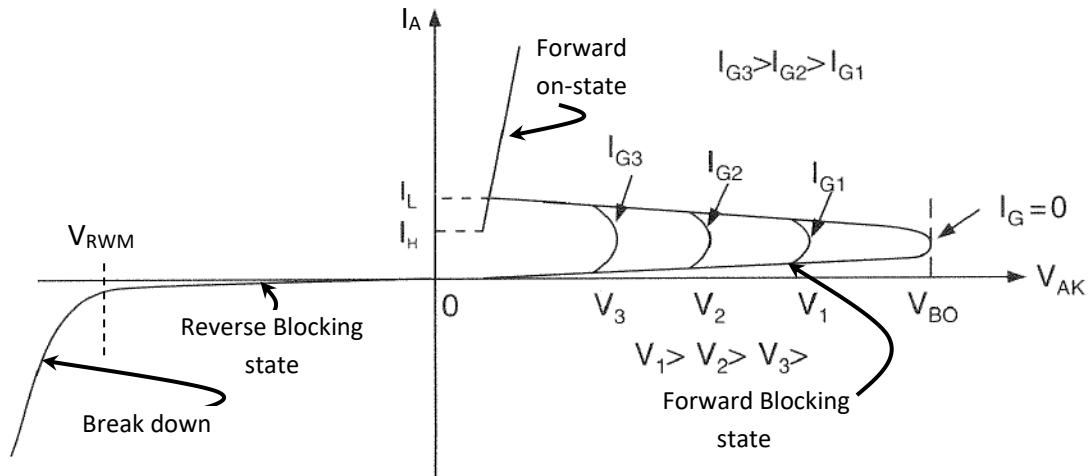

**The Latching Current ( $I_L$ ):** is the minimum Anode current required to maintain the Thyristor in the on-state immediately after the Thyristor has been turned on and the gate signal has been removed.

**The Holding Current ( $I_H$ ):** is the minimum Anode current that can flow through the Thyristor and still maintain the device in the on-state;  $I_H \sim$  milli Amperes.

Note that  $I_H < I_L$ , because the gain of the two equivalent transistors ( $\alpha_1$  and  $\alpha_2$ ) is higher when the SCR is conducting.

$V_{BO}$ : the Forward Break-Over Voltage

$V_{RWM}$ : the Reverse Working Voltage

The on-state voltage drop ( $V_{on}$ ) is 1-3V depending on the voltage rating, and is represented by:

$$V_{AK(on)} = V_{J1} - V_{J2} + V_{J3} + V_n$$

The i-v characteristic of the SCR can be idealized as shown in the Figure next.

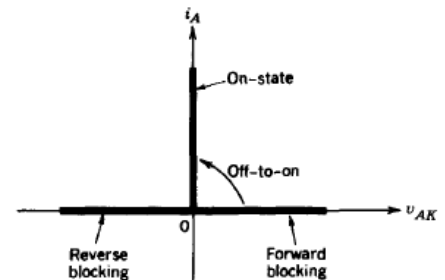

## Turn-on

- ◆ It can be turned on by applying a pulse of positive gate current for a short period of time provided that the device is in the forward blocking state ( $V_A > V_K$ ). Once the device is latched on the gate current can be removed and the gate circuit loses control over the Thyristor.
- ◆ The Gate current ( $I_G$ ) is in the range of 0.1A to 0.3A for 6000A device, and the Gate-Cathode signal required to turn-on a forward biased device is  $V_{gk} \approx 3V - 5V$ .
- ◆ The Figure below shows an SCR implemented in a simple chopper circuit.

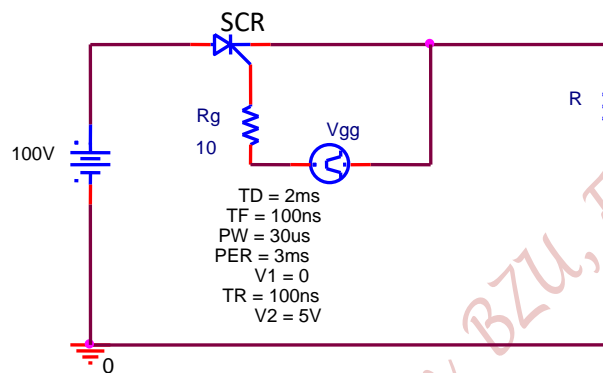

- ◆ The switching waveforms are shown below. The Thyristor is turned on by applying a pulse of gate current, and stays on as long as the Anode current is greater than the Latching current, even if the gate pulse is removed. Applying another pulse of gate current has no effect on the Thyristor.
- ◆ Negative gate currents are prohibited as they fail to turn-off the whole cells in the device and they may cause hot spots, which damage the SCR. Hence, a protection Diode may be connected in series with the SCR's Gate terminal to rectify the Gate current direction.

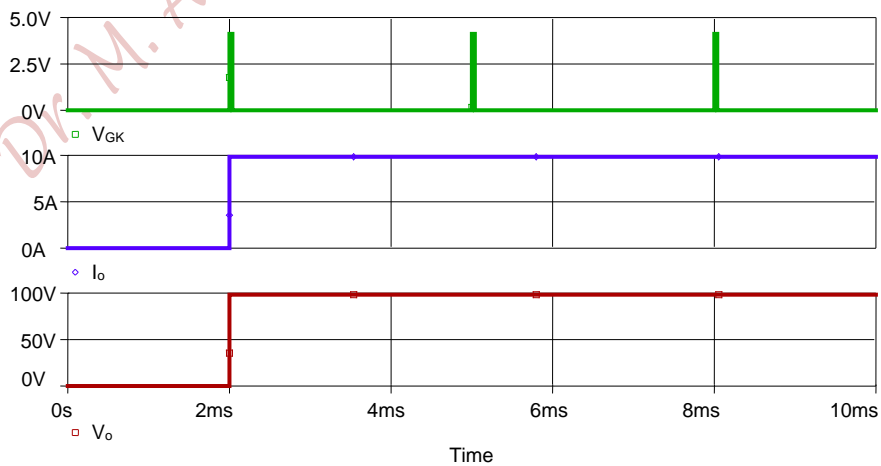

- ◆ The minimum positive gate pulse width should be greater than the time needed for the Anode current to become greater than the Latching current (important for RL loads as shown below).

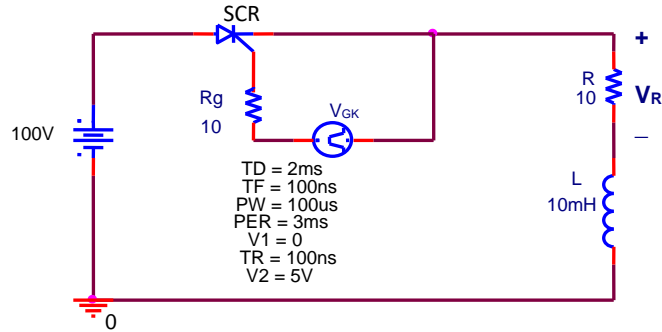

- ◆ The switching waveforms for an RL load are shown below.

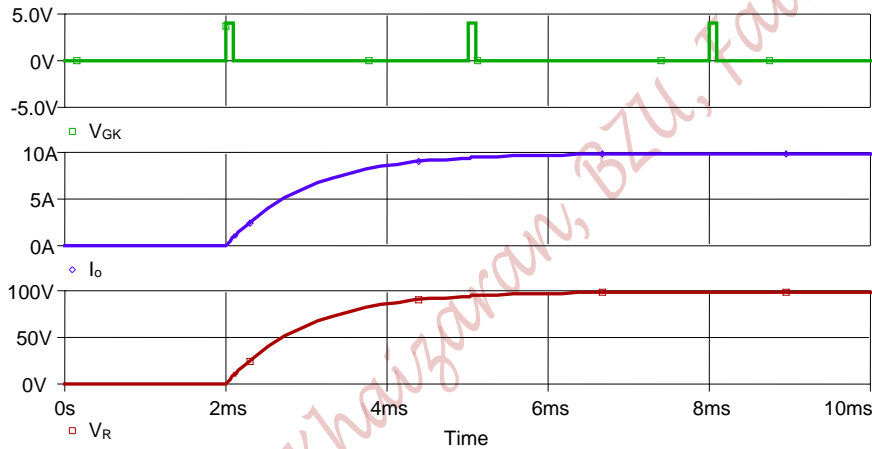

**Turn-off:**

The SCR can be turned off by an external circuit forcing the Anode current through the device to be less than the Holding current.

**Turn-off time ( $t_q$ ):** is the time interval between the instant when the principal current has decreased to zero, after external switching of the principal voltage, and the instant when the Thyristor is capable of supporting a forward voltage without turning on, as illustrated next. Normally, it is in the range of  $50\mu s$  to  $100\mu s$ .

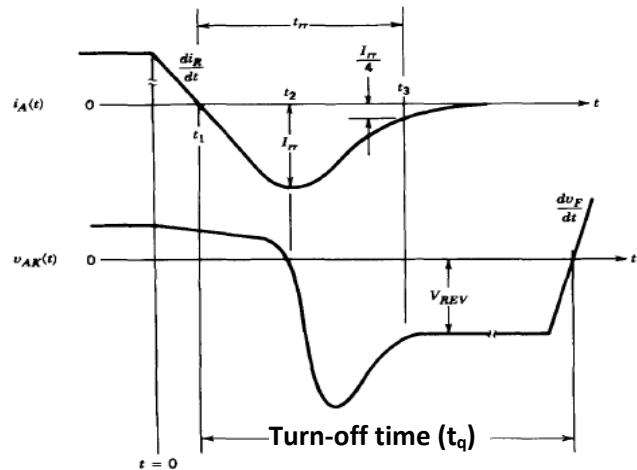



## Types of Thyristors

1. **Phase-Control Thyristor**: It is used in rectifying the line frequency voltage and current. It has high current and voltage capabilities  $\sim 8\text{kV}$  and  $6\text{kA}$ . In fact, it has the highest power ratings amongst power electronic devices and it has the lowest on-state voltage drop ( $V_{on}$ ). But, the switching frequency is very low; less than  $200\text{Hz}$ !
2. **Inverter-Grade Thyristor**: It has a small  $t_q$  (few micro seconds to  $50\mu\text{s}$ ) compared to the first type. But the on-state voltage drop ( $V_{on}$ ) is higher and the power rating is lower than that of the first type.
3. **Light Activated Thyristor**: It is triggered on by a pulse of light guided by optical fibers; light with an appropriate wave length generates hole–electron pairs in the Silicon. Rating  $\sim 4\text{kV}$  and  $1500\text{A}$

Types 1 and 2 are manufactured according to a compromise between ( $t_q$  & switching speed) and (on-state voltage drop & power ratings).

## Turning off Thyristors

A conducting Thyristor cannot be turned off via its gate. However, to turn it off, the value of the Anode current has to fall below the Holding current.

In AC circuits, the current is sinusoidal and naturally falls below the Holding current. The turn-off process is called self commutation. In these circuits, the Thyristor is self-turned off.

If Thyristors are used in Controlled Rectifiers or Inverters, they are turned off in a process called Line or Load commutation, respectively. Commutation to indicate that the SCR's current commutates to another path in the circuit.

In DC circuits, an extra circuit is added (to the power circuit) to assist turning off the conducting Thyristor. Commutation Circuits are named according to the strategy implemented to achieve current commutation and Thyristor's turn-off. **Various types of Commutation Circuits** are available, some of these:

- 1- Resonant Commutation Circuit
- 2- Impulse Commutation Circuit
- 3- Complementary Commutation Circuit
- 4- External Pulse Commutation Circuit
- 5- Load-Side Commutation
- 6- Line-Side Commutation

## Resonant Commutation Circuit

An example of a Resonant Commutation Circuit is shown in the Figure below, and marked in a dashed box. It consists of two Thyristors ( $T_{C1}$  and  $T_{C2}$ ), an inductor ( $L$ ), and a capacitor ( $C$ ).

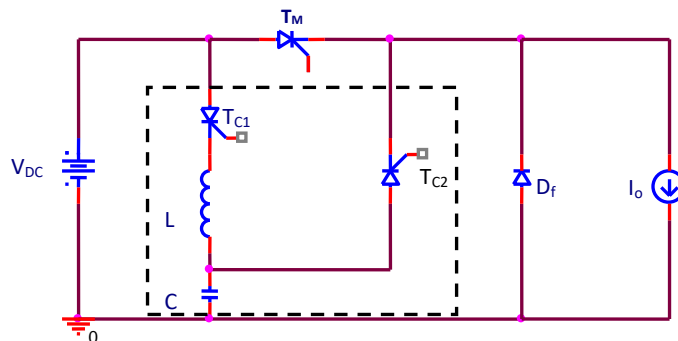

## Principle of Commutation Circuit Operation

The complete simulation circuit is shown in the Figure below. The load is assumed to be highly inductive and is represented by a current source (of 30A, in this case).

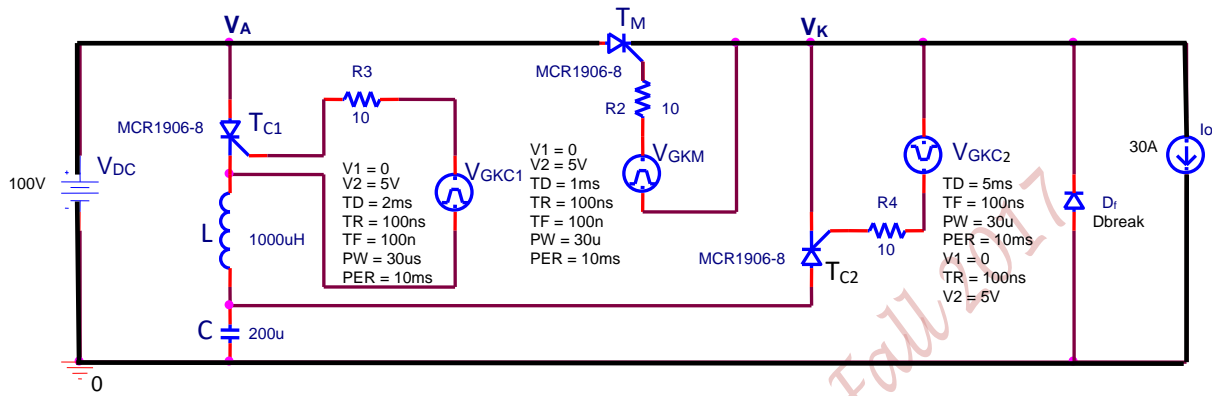

The waveforms, shown below, illustrate the circuit operation and commutation steps.

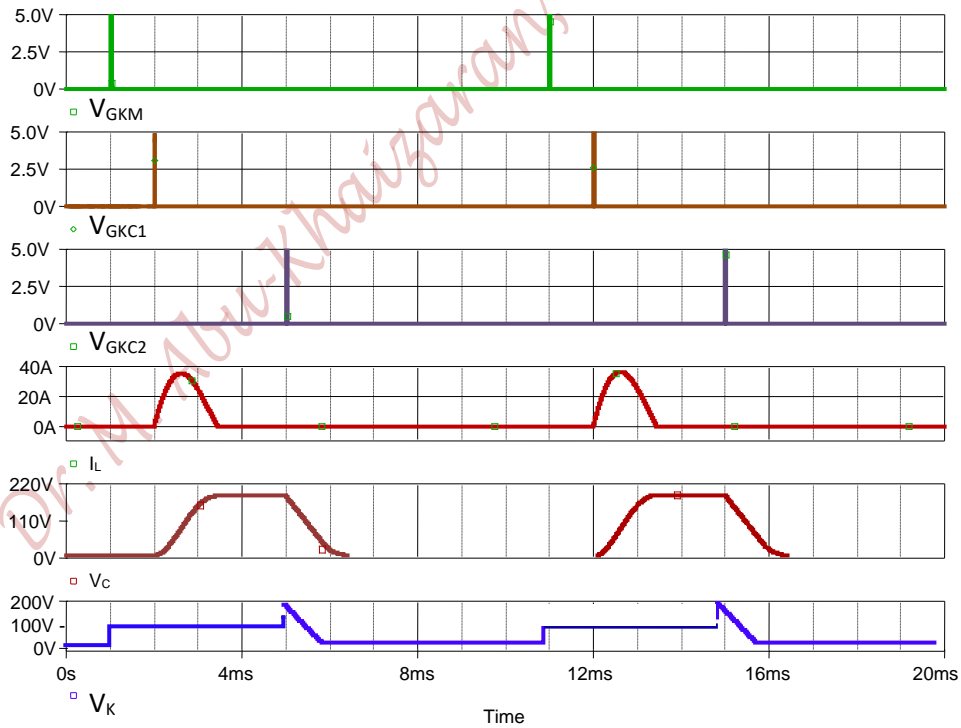

- ▶ The main SCR ( $T_M$ ) is turned on at  $t = 1ms$ .
- ▶ Commutation is achieved by the following steps:
  - ◆ When  $T_{C1}$  is triggered (fired) (in this case at  $t = 2ms$ ), a resonant LC circuit is formed, as shown in the dashed box below.

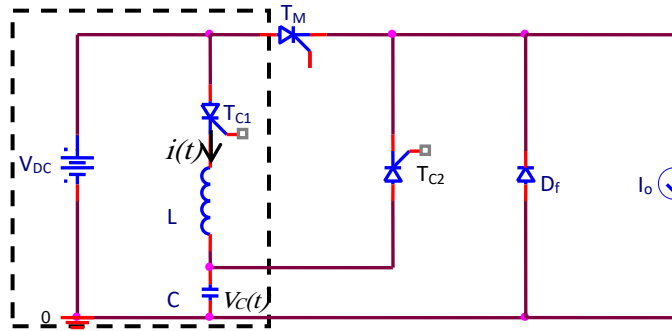

Applying KVL for the resonant LC circuit yields (neglecting the voltage drop across  $T_{C1}$  ( $V_{on}$ )):

$$V_{DC} = L \frac{di(t)}{dt} + \frac{1}{C} \int i(t) dt$$

The inductor current (also,  $i_{T_{C1}}$ ) is:

$$i(t') = A \sin \omega_o t' + B \cos \omega_o t' ; \quad 0s \leq t' \leq \frac{\pi}{\omega_o} : \text{ after redefining the time origin } t' = 0 \text{ at } t = 2ms.$$

where the Resonant Frequency is:

$$\omega_o = \frac{1}{\sqrt{LC}}$$

Initially, the inductor current is zero; i.e. at  $t' = 0s$ ,

$$I = 0 \Rightarrow B = 0$$

Therefore,

$$A = \frac{V_{DC}}{\omega_o L}$$

$$i(t') = \frac{V_{DC}}{\omega_o L} \sin \omega_o t' ; \quad 0s \leq t' \leq \frac{\pi}{\omega_o}$$

The capacitor voltage is:

$$V_C(t) = \frac{1}{C} \int i(t) dt + constant$$

$$\Rightarrow V_C(t') = V_{DC}(1 - \cos \omega_o t') ; \quad 0s \leq t' \leq \frac{\pi}{\omega_o}$$

- ◆ At  $\omega_o t' = \pi$ ,  $V_C = 2V_{DC}$ , and  $T_{C1}$  turns off as its current falls below its Holding value (the current cannot be negative in an SCR).
- ◆ The capacitor holds its charge because  $T_{C2}$  is off. And the resonant circuit is ready to turn-off the main Thyristor at will.
- ◆ When the main SCR is to be turned off,  $T_{C2}$  is triggered (in this case, at  $t = 5ms$ ) applying a reverse voltage across the main Thyristor ( $V_A = V_{DC}$  and  $V_K = 2V_{DC}$ ). Hence, causing the main Thyristor's current to commute to  $T_{C2}$ .
- ◆ The load current ( $I_o$ ) is now supplied from the capacitor's charge, and the capacitor starts discharging linearly because the load current is constant; i.e.,

$$I_o = C \frac{dV_C}{dt}$$

- ◆ For a successful turn-off of the main Thyristor and proper commutation, the capacitor voltage, and thus  $V_K$ , must not fall below  $V_{DC}$  within a time less than the turn-off time of the main SCR ( $t_q$ ). Therefore, the value of the capacitor ( $C$ ) is selected according to:

$$C = I_o \frac{\Delta t}{\Delta V}$$

where  $\Delta t \geq t_q$  of the main Thyristor, and  $\Delta V (= 2V_{DC} - V_{K \text{ final}}) \leq V_{DC}$ .

Note that the inductor value dictates the value of the required resonant frequency.

- ◆ The main Thyristor is turned on again (at  $t = 11ms$ , in this case) and the procedure for commutation is repeated!

## TRIACs

A TRIAC name is from **TRI**ode (3 Diodes) for **Al**ternating **C**urrent. The TRIAC symbol is shown in the Figure next. It has 3 terminals: MT<sub>1</sub>, MT<sub>2</sub> and the Gate.

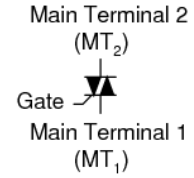

It is equivalent to two anti-parallel Thyristors as shown in the Figure next.

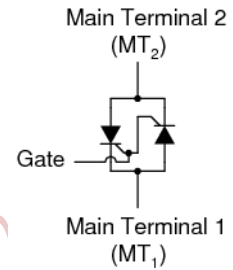

The current-voltage characteristics of a TRIAC are shown in the Figure below.

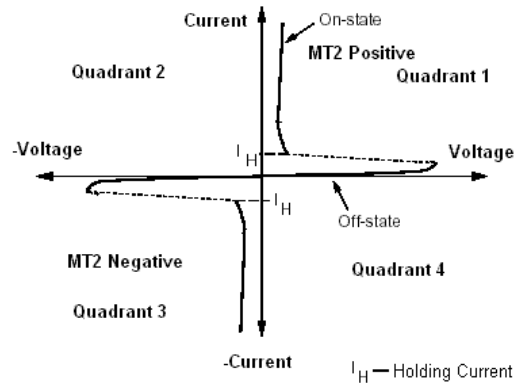

A TRIAC can conduct current in both directions. To conduct a current in a particular direction (e.g. from MT<sub>2</sub> to MT<sub>1</sub>), the respective Thyristor of the equivalent Thyristors should be forward biased (i.e.  $V_{MT2} > V_{MT1}$ ) and an appropriate pulse of gate current (+10mA to +100mA) is applied.

Hence, it is used in AC circuits; typical Applications: AC voltage controllers and Light Dimmers (as in the Figure below). The value of the output voltage can be controlled by the gate of the TRIAC; via the firing angle.

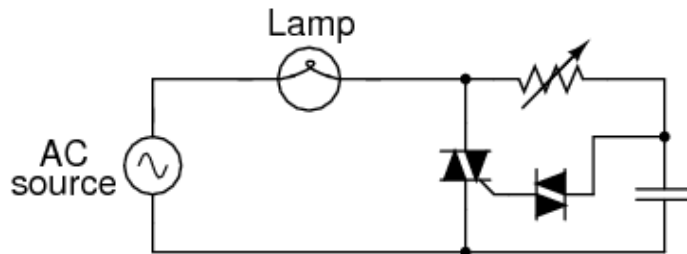

## Switching Waveforms of a TRIAC

A TRIAC may be implemented in the circuit below to control the output voltage (rms value).

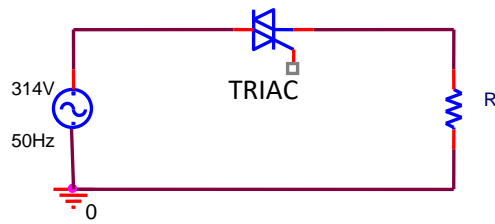

The switching waveforms are shown below. Portions of the sinusoidal voltage are chopped, resulting in a lower rms voltage at the output.

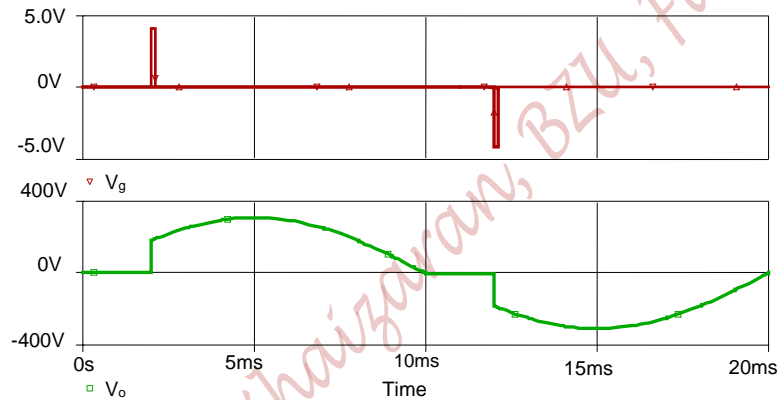

The voltage and current ratings of TRIACs are moderate compared to that of Thyristors; up to 1000V, and less than 100A.

## Switching in Controllable Switches

Some of the desired characteristics of an ideal switch are:

1. Blocks arbitrary large forward and reverse voltage with zero current flowing during off
2. Conducts arbitrary large current with zero voltage when on
3. Switches from on to off or vice versa instantaneously at will
4. Vanishingly small power required from the gate drive to control the switch

However, real devices do not have ideal characteristics and, therefore, dissipate power when used.

Too much power dissipation may lead to destruction of the device. There are **two main sources of power dissipation**:

- i) Switching Losses
- ii) Conduction Losses

## Power Dissipation in a Chopper Switch with an Inductive Load

Consider the chopper circuit shown in the Figure below. The current source represents a highly inductive load. The diode provides a continuous path for the load current when the switch is turned off. Hence, the diode clamps the voltage and prevents the occurrence of destructive voltage spikes.

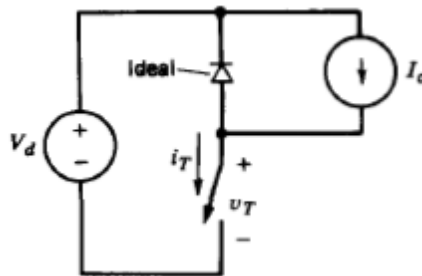



The switching waveforms of a controllable switch implemented in the chopper circuit controlling an inductive load are:

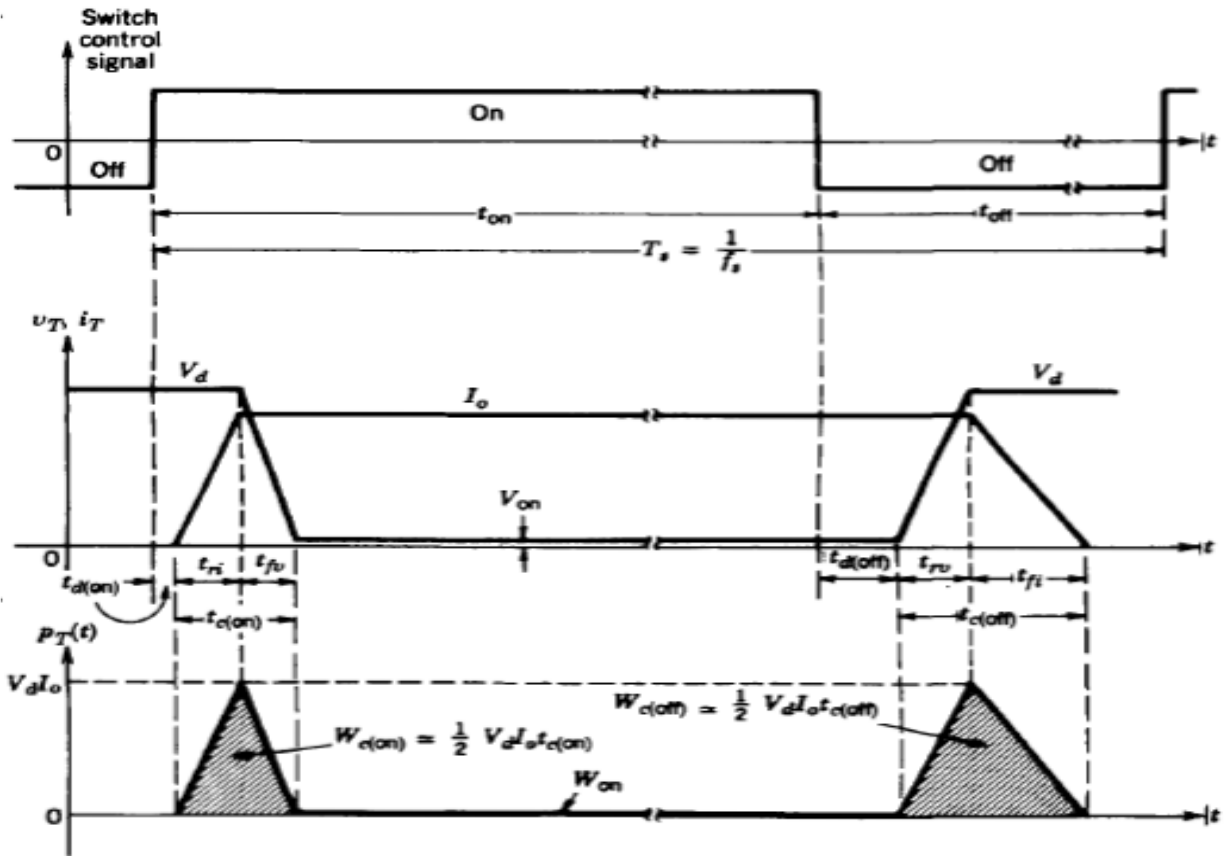

Define the turn-on crossover time as:

$$t_{c(on)} = t_{ri} + t_{fv}$$

At turn-on, the energy dissipated in the device can be approximated as:

$$W_{c(on)} = \frac{1}{2} V_d I_o t_{c(on)}$$

The turn-off crossover time is:

$$t_{c(off)} = t_{rv} + t_{fi}$$

During turn-off, the energy dissipated in the switch ( $W_{c(off)}$ ) is;

$$W_{c(off)} = \frac{1}{2} V_d I_o t_{c(off)}$$

There are  $f_s$  turn-on and turn-off transitions, where  $f_s$  is the switching frequency and equals  $1/T_s$ .

Therefore, the average switching power loss in the switch ( $P_s$ ) with highly inductive load can be approximated as:

$$P_s = \frac{1}{2} f_s V_d I_o (t_{c(on)} + t_{c(off)})$$

Devices with short switching times can operate at high switching frequencies, which reduce filtering requirements.

During conduction, the energy dissipated in the switch is:

$$W_{on} = V_{on} I_o t_{on} \quad ; \quad t_{on} \gg t_{c(on)} \text{ or } t_{c(off)}$$

The average power loss dissipation during conduction ( $P_{on}$ ) is:

$$P_{on} = \frac{V_{on} I_o t_{on}}{T_s}$$

$$P_{on} = V_{on} I_o t_{on} f_s$$

The energy dissipated in the device may be removed by heat sinks, shown in the Figures below, or snubbers depending on the device used.



**Example: Power Dissipation in a Controllable Switch Implemented in a Chopper Circuit Controlling a Resistive Load**

Assuming linear voltage and current switching and  $V_{on} \ll V_d$ ,

- I. Plot the switching waveforms and find the average power loss in the switch shown in the circuit next.
- II. If  $V_d = 300V$ ,  $f_s = 100kHz$ ,  $R = 75\Omega$ ,  $t_{c(on)} = 150ns$  and  $t_{c(off)} = 300ns$ , calculate the switching power loss.

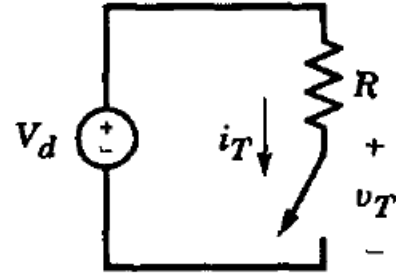

**Solution:**

The switching waveforms are shown in the Figure next.

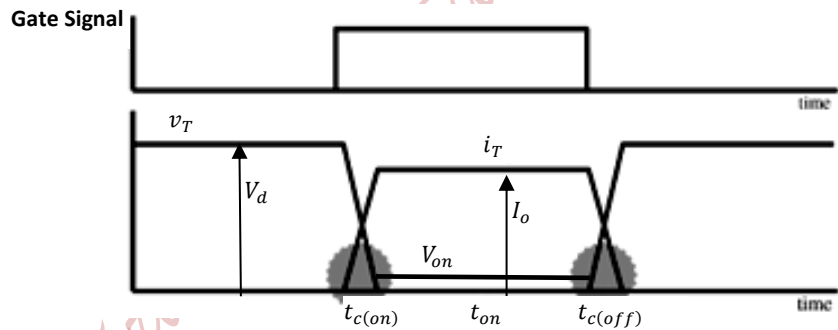

At turn-on transition, the energy loss is:

$$W_{c(on)} = \int P_{c(on)} dt = \int_0^{t_{c(on)}} i_T(t) v_T(t) dt$$

For  $0 < t < t_{c(on)}$ , the switch current rises linearly as:

$$i_T(t) = I_o \frac{t}{t_{c(on)}}$$

and the switch voltage falls also linearly as

$$v_T(t) = V_d \left( 1 - \frac{t}{t_{c(on)}} \right)$$

Therefore, the turn-on energy loss is:

$$W_{c(on)} = \int_0^{t_{c(on)}} I_o \frac{t}{t_{c(on)}} V_d \left( 1 - \frac{t}{t_{c(on)}} \right) dt$$

$$W_{c(on)} = \int_0^{t_{c(on)}} \frac{I_o V_d}{t_{c(on)}} \left( t - \frac{t^2}{t_{c(on)}} \right) dt$$

$$W_{c(on)} = \frac{I_o V_d}{t_{c(on)}} \left( \frac{t^2}{2} - \frac{t^3}{3t_{c(on)}} \right) \Big|_0^{t_{c(on)}}$$

$$W_{c(on)} = \frac{I_o V_d}{t_{c(on)}} \left( \frac{t_{c(on)}^2}{2} - \frac{t_{c(on)}^2}{3} \right)$$

$$W_{c(on)} = \frac{I_o V_d}{t_{c(on)}} \left( \frac{t_{c(on)}^2}{6} \right)$$

$$W_{c(on)} = \frac{I_o V_d t_{c(on)}}{6}$$

Similarly, during turn-off transition, the current falls linearly as:

$$i_T(t) = I_o \left( 1 - \frac{t}{t_{c(off)}} \right) ; \quad 0 < t < t_{c(off)}$$

and the voltage rises linearly as:

$$v_T(t) = V_d \frac{t}{t_{c(off)}}$$

Thus, the energy loss at turn-off is:

$$W_{c(off)} = \int_0^{t_{c(off)}} I_o \left( 1 - \frac{t}{t_{c(off)}} \right) V_d \frac{t}{t_{c(off)}} dt$$

$$W_{c(off)} = \int_0^{t_{c(off)}} \frac{I_o V_d}{t_{c(off)}} \left( t - \frac{t^2}{t_{c(off)}} \right) dt$$

$$W_{c(off)} = \frac{I_o V_d}{t_{c(off)}} \left( \frac{t^2}{2} - \frac{t^3}{3t_{c(off)}} \right) \Big|_0^{t_{c(off)}}$$

$$W_{c(off)} = \frac{I_o V_d}{t_{c(off)}} \left( \frac{t_{c(off)}^2}{2} - \frac{t_{c(off)}^2}{3} \right)$$

$$W_{c(off)} = \frac{I_o V_d}{t_{c(off)}} \left( \frac{t_{c(off)}^2}{6} \right)$$

$$W_{c(off)} = \frac{I_o V_d t_{c(off)}}{6}$$

The total switching energy loss is:

$$W_c = W_{c(on)} + W_{c(off)} = \frac{I_o V_d}{6} (t_{c(on)} + t_{c(off)})$$

Total average switching power loss with resistive load is:

$$P_s = \frac{1}{6} f_s V_d I_o (t_{c(on)} + t_{c(off)})$$

Note that, the switching power loss for resistive load is 1/3<sup>rd</sup> that for inductive load.

During conduction, the energy loss in the switch is:

$$W_{on} = V_{on} I_o t_{on} \quad ; \quad t_{on} \gg t_{c(on)} \text{ or } t_{c(off)}$$

The average conduction power loss is:

$$P_{on} = V_{on} I_o f_s t_{on}$$

For the given values:  $P_s = \frac{1}{6} \times (100 \times 10^3) \times 300 \times 4 \times [150 + 300] \times 10^{-9} = 9 \text{ W}$

Dr. M. Abu-Khaizaram, BZU, Fall 2017

## Snubbers

They are circuits consisting of circuit elements such as: R, L, C, or Diodes, and are used to protect the power device from high  $dv/dt$ ,  $di/dt$ , or switching power loss. They are **two main types**:

### A) Turn-Off Snubber:

An example of a turn-off snubber circuit for a GTO is shown in the Figure below. "R" limits the discharging current, and dissipates the capacitor energy.

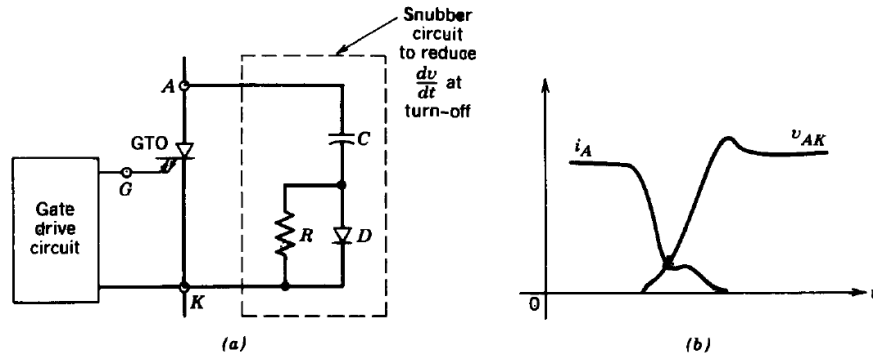

### B) Turn-On Snubber

An example of a turn-on snubber for a BJT is shown next.

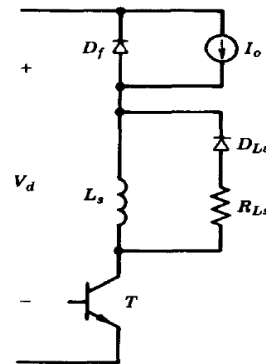

" $R_{Ls}$ " sets the discharging rate of the inductor energy. The effect of the value of " $L_s$ " in the turn-on snubber on the switching waveforms at turn-on is shown in the Figures below.

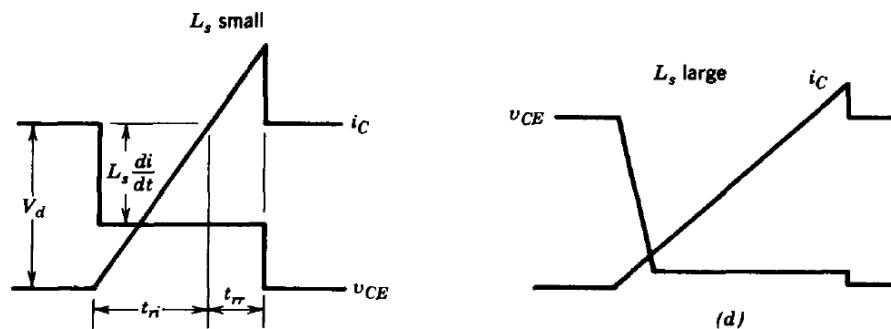

## Desired Characteristics of Controllable Switches

1. A small leakage current during off-state
2. A small on-state voltage ( $V_{on}$ ) → minimize conduction power loss
3. Short turn-on and turn-off times → minimize switching power loss
4. Large forward and reverse blocking capabilities → no need for seriesing devices
5. High on-state current ratings → no need for paralleling devices
6. Positive temperature coefficient of on-state resistance → parallel devices will share the current equally (e.g. Power MOSFET)

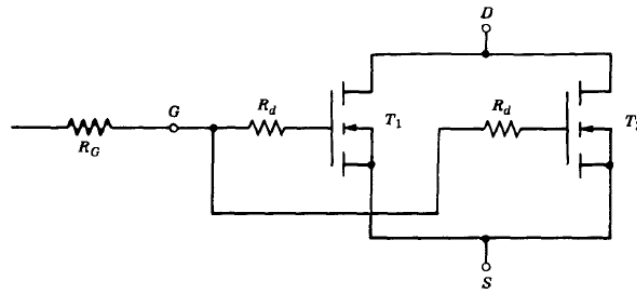

7. Small control power – simplify the control circuit design
8. Capability to withstand rated voltage and rated current simultaneously while switching → eliminates the need for snubbers (protection circuits)
9. Large  $di/dt$  and  $dv/dt$  ratings → no need for snubbers to slow down switching, which are usually used with the SCR and its derivatives.

## Types of Controllable Switches

### A) Gate Turn-Off Thyristors (GTOs)

- They are minority carrier devices, usually with a forward blocking capability only. However, some could have also a reverse blocking capability.
- The GTO, as its name indicates, can be turned off via the gate.
- The GTO is a self turn-off Thyristor, but has a higher on-state voltage ( $V_{on}$ ) than that of an equivalent SCR (for example, 3.4V for 1.2kV and 500A device).
- The symbol of a GTO, shown below, has two directional arrows at the Gate terminal to indicate that both directions of gate current are allowed. The other terminals are the Anode (A) and Cathode (K).

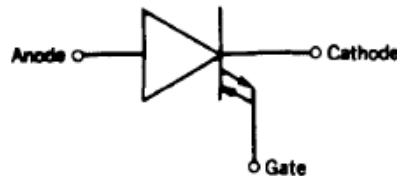

- A GTO has a highly interdigitated Gate-Cathode structure for faster switching; to simplify drawing a large gate current to turn-off all the cells in the device, simultaneously.

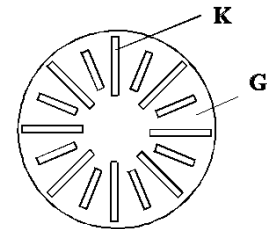

#### ➤ Layers' Structure

The layers' structure of the GTO is shown in the Figure next. It is modified from the Thyristor's structure by having  $n^+$ -well at the Anode terminal, and also having Anode Shorts. These modifications help the turn-off process, without a much reduction of the carriers' life time.

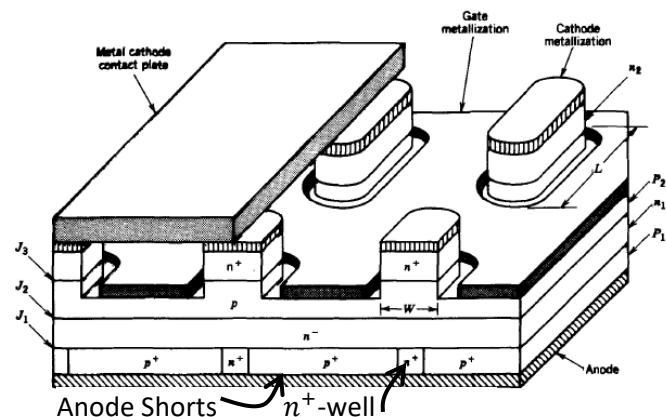

The  $n^+$ -well operates as a sink to holes at turn-off.



The **Anode Shorts speed up the turn-off process** by removing the holes from  $n^+$  layer (and electrons from the  $p^+$  layer) by recombination and diffusion. This avoids reducing the life time of carriers to extreme values, which increases  $V_{on}$  to unacceptable values.

However, **with Anode Shorts the GTO has no reverse blocking capability** (might be a disadvantage in some applications such as Current Source Inverters (CSIs)).

### ➤ GTO's Switching

For a GTO implemented in the simple chopper circuit, the switching waveforms are as shown below.

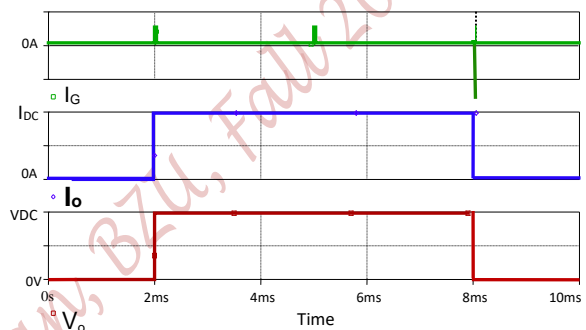
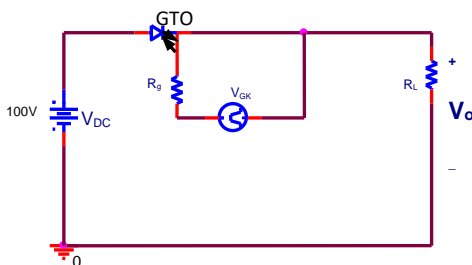

#### Turn-on:

When forward biased, it can be turned on by a short pulse of positive current applied to the gate.

#### Turn-off:

A GTO can be turned off by a short pulse ( $\sim 50\mu s$ ) of negative current drawn from the gate. However, the gate current must be very large, on the order of  $1/5^{\text{th}}$  to  $1/3^{\text{rd}}$  (corresponding to **Turn-off Gains ( $\beta_{off} = \frac{I_A}{I_{G(off)}}$ ) of 5 to 3**) of the anode current being turned off.

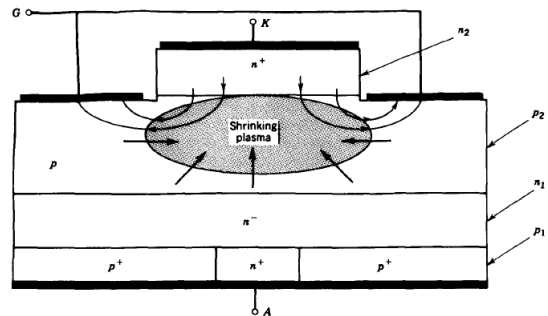

- Some GTOs' ratings could reach 6kA and 6kV.
- The Thyristor's family has poor switching capability; for GTOs the maximum switching frequency is less than 1kHz.
- An **Integrated Gate Commutated Thyristor (IGCT)** is a GTO with an optimized gate drive manufactured with the power device in one package. The Figure next shows samples of press-pack IGCTs.



## B) Power Bipolar Junction Transistors (BJTs)

➔ Samples of Power Bipolar Junction Transistors are shown below.

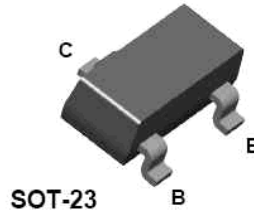

➔ They are minority carrier devices.

➔ They are either npn or pnp type, whose symbols are shown below.

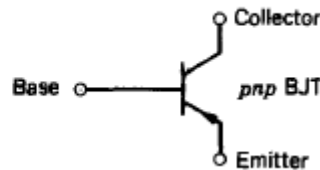
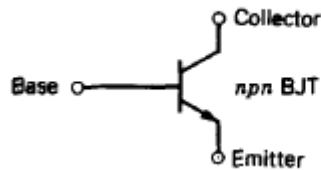

➔ npn type is more commonly used, as it has higher ratings for the same device size, because the mobility of electrons is higher than (about 3 times) that of holes; the npn type has a smaller size for the same power ratings.

➔ The layers' structure for npn power BJT is shown in the Figure below. It has a thick base and a wide drift region to accommodate the depletion layer associated with blocking high voltages.

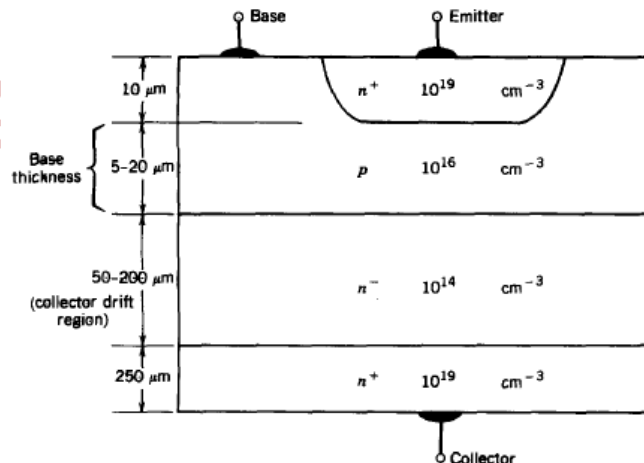

➔ A Power BJT has a forward voltage blocking capability only!

## Current-Voltage Characteristics of BJTs

The i-v characteristics of an npn type is shown in the Figure next.

A Power BJT transistor has four operating regions:

- I. Cut off:  $I_B < 0A$
- II. Active region: the Collector current ( $I_C$ ) is controlled by the Base current ( $I_B$ );  $I_C = \beta I_B$
- III. Quasi saturation
- IV. Hard Saturation: the load limits the collector current, whilst the voltage drop across the device  $V_{ce(sat)}$  is minimized.

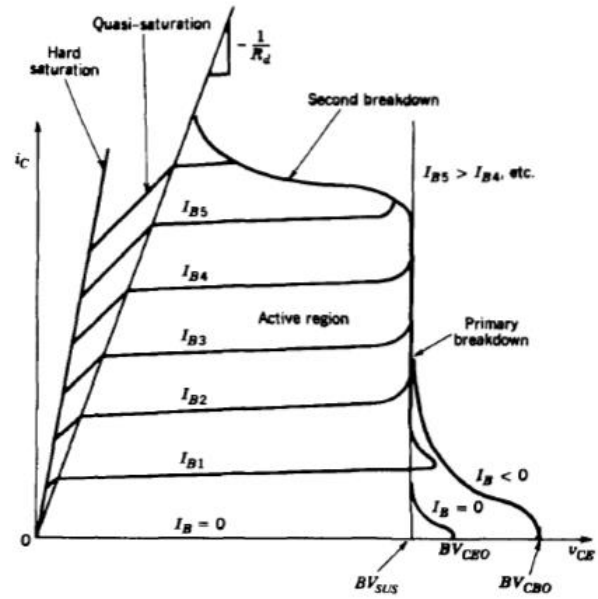

- ▶  $BV_{CEO}$ : Collector-Emitter Breakdown voltage when the base is open circuited
- ▶ In the Active region, the Collector current ( $I_C$ ) is related to the Base current ( $I_B$ ) by:

$$I_C = \beta I_B$$

where  $\beta: 5 - 10$ ; it is small because of the thick base.

- ▶ To be fully on with low voltage drop,  $I_B$  should be greater than  $I_B = \frac{I_C}{\beta}$
- ▶ A Power BJT is a current-controlled device, therefore it needs a continuous Base current to keep it in the on-state.
- ▶ The switching waveforms of a Power BJT implemented in a chopper circuit are illustrated below.

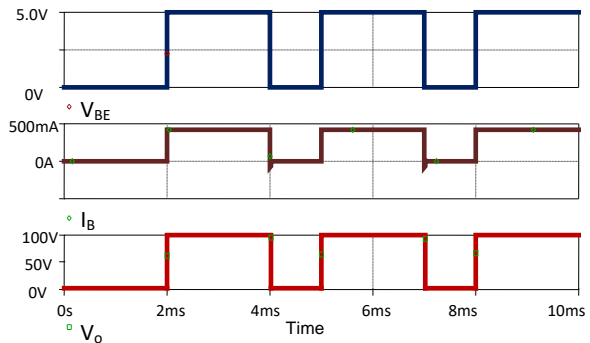
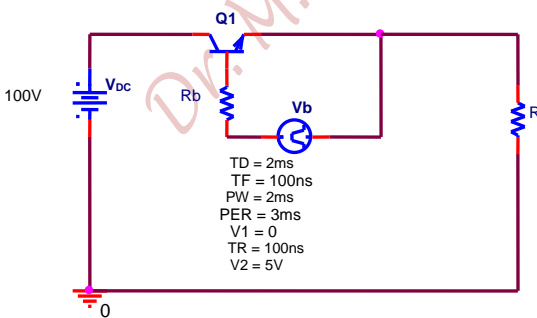

- ▶ During conduction, and Hard Saturation, the voltage drop  $V_{ce(sat)}$  is in the range 1 to 2V.

- ▶ The switching time ranges from hundred nanoseconds to few micro seconds, thus the switching frequency is up to  $\sim 10\text{kHz}$ .
- ▶ BJTs have higher switching capabilities than that of the Thyristors and their derivatives.
- ▶ BJT is available in a voltage rating up to 1500V and a current rating of few hundred Amps; 1.2kA and 1500V device is available.

- ▶ BJT does not have a square Forward Biased Safe Operating Area, as shown in the Figure next, which necessitates the need for connecting turn-on and turn-off snubbers when switching a highly inductive load.

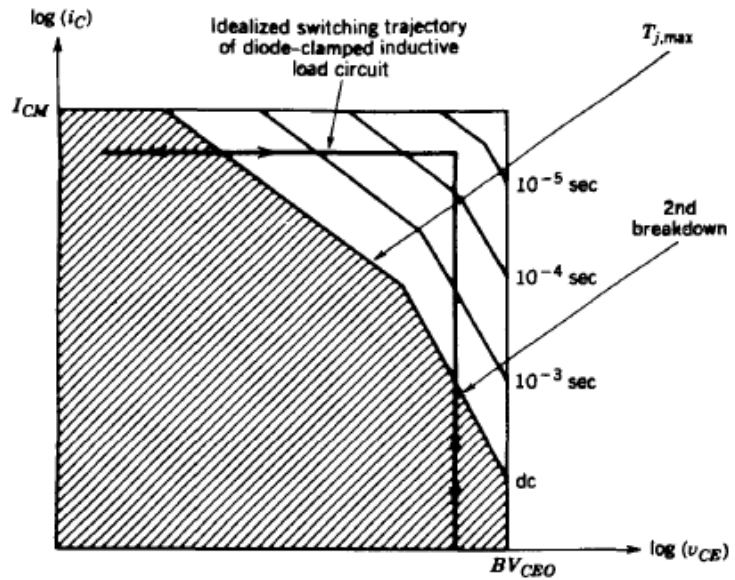

- ▶ The current capability of a BJT may be increased by using a **Darlington configuration** (double (Figure (a) below) or triple Darlington (Figure (b) below)). However, a Darlington configuration is slower. If the Darlington is manufactured on a single chip, then it will be called monolithic Darlington.

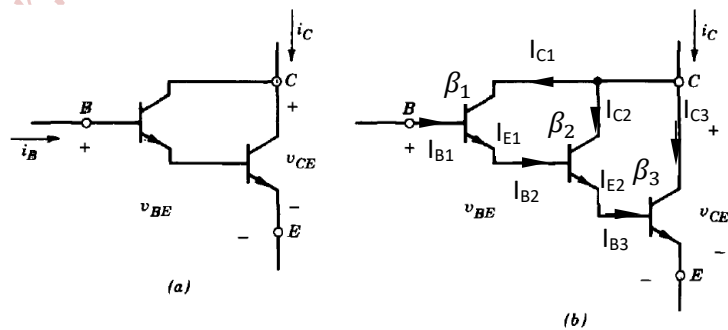

**Example:** Find the current gain ( $G = \frac{I_C}{I_B}$ ) of the triple Darlington

$$I_{C1} = \beta_1 I_{B1} = \beta_1 I_B$$

$$I_{E1} = (1 + \beta_1) I_B$$

$$I_{C2} = \beta_2 I_{E1}$$

$$I_{C2} = \beta_2 (1 + \beta_1) I_B$$

$$I_{E2} = (1 + \beta_2) (1 + \beta_1) I_B$$

$$I_{C3} = \beta_3 I_{E2}$$

$$I_{C3} = \beta_3 (1 + \beta_2) (1 + \beta_1) I_B$$

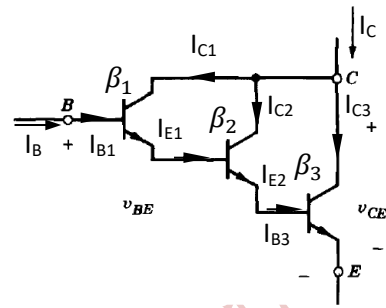

Current Gain:

$$G = \frac{I_C}{I_B}$$

$$G = \frac{I_{C1} + I_{C2} + I_{C3}}{I_B}$$

$$G = \frac{\beta_1 I_B + \beta_2 (1 + \beta_1) I_B + \beta_3 (1 + \beta_2) (1 + \beta_1) I_B}{I_B}$$

$$G = \frac{\beta_1 + \beta_2 (1 + \beta_1) + \beta_3 (1 + \beta_2) (1 + \beta_1)}{1}$$

$$G = B_1 + B_2 + B_3 + B_1 B_2 + B_1 B_3 + B_2 B_3 + B_1 B_2 B_3$$

Therefore, the total current gain is:

$$G = B_1 + B_2 + B_3 + B_1 B_2 + B_1 B_3 + B_2 B_3 + B_1 B_2 B_3$$

### C) Power Metal–Oxide–Semiconductor-Field-Effect-Transistor (MOSFET)

- ▶ A Power MOSFET is an extension to enhanced MOSFET.
- ▶ Power MOSFETs are of two types; n-channel (Figure (a) below) and p-channel (Figure (b) below).

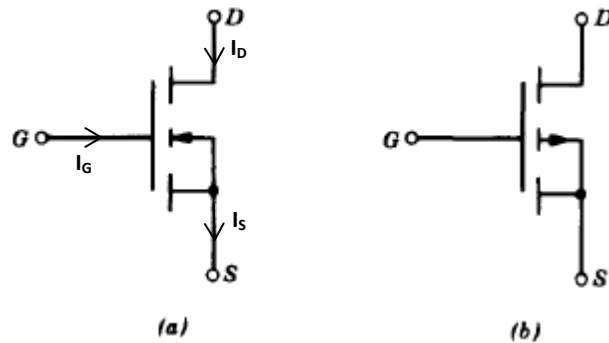

- ▶ The terminals are named: Gate (G), Drain (D) and Source (S).
- ▶ The layers' structure of an n-channel Power MOSFET is shown in the Figure below.

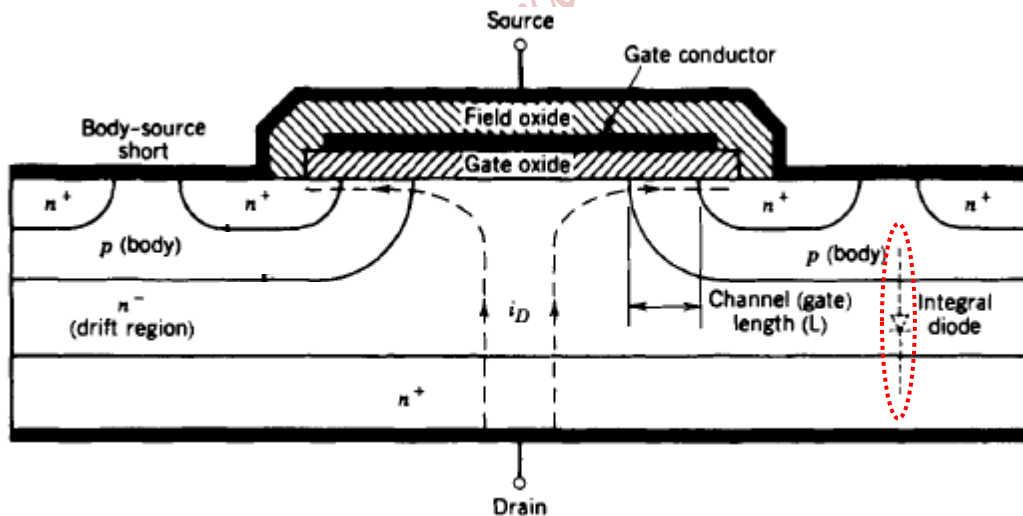

- ▶ The structure has a built in **Anti-parallel diode** or Integral (Body) diode between the Source and the Drain. Therefore, it **has no reverse blocking capability**.
- ▶ A Power MOSFET is a majority carrier device and has a forward blocking capability only.

- ▶ The i-v (output) characteristic of an n-channel Power MOSFET is shown in the Figure below. It has three main regions: The Cut-off region, the Active (Saturation) region, and the Ohmic region.

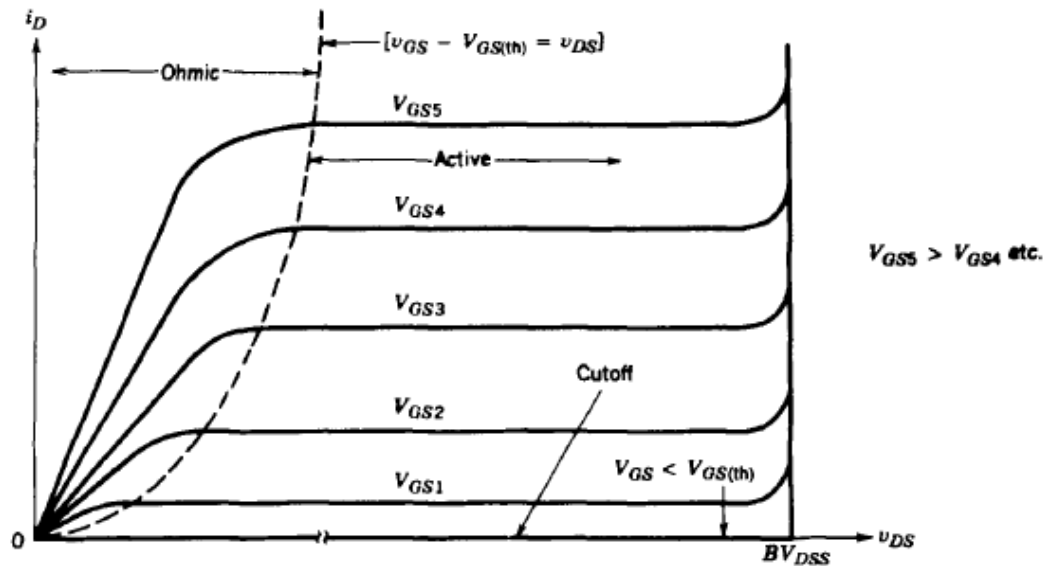

- ▶ For p-channel MOSFET, the i-v characteristic is in the 3<sup>rd</sup> quadrant.
- ▶  $BV_{DSS}$ : is the Forward Breakdown Voltage.
- ▶ A Power MOSFET is in the Cut-off region when the Gate-Source voltage ( $V_{GS}$ ), for n-channel, is less than the Threshold voltage ( $V_{GS(th)}$ ) (2V to 4V); the device is blocking.
- ▶  $V_{GS(th)}$ : is the minimum Gate-Source voltage required to form a channel (an inversion layer) and turn-on the device.
- ▶ When the Gate-Source voltage is increased above the Threshold voltage, the inversion layer is formed as illustrated below, and the MOSFET becomes conductive.

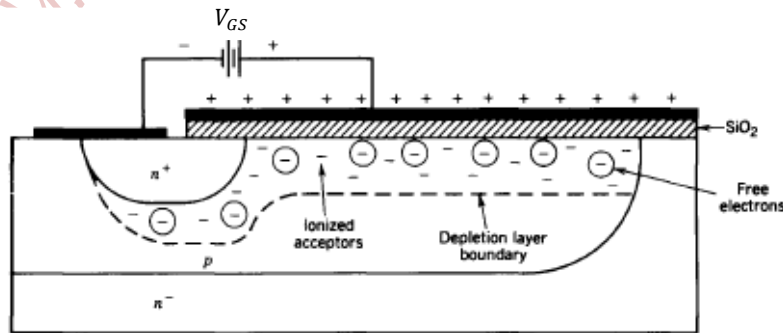

- ▶ A MOSFET is a voltage-controlled device. It requires a continuous Gate-Source voltage to keep it on.

- ▶ When operating in the Active region, the Drain current ( $I_D$ ) is controlled by the Gate-Source voltage ( $V_{GS}$ ) by:

$$I_D = k(V_{GS} - V_{GS(th)})^2$$

where  $k$  depends on the device geometry and doping levels.

- ▶ When operated as a switch (in the **Ohmic region**), the on-state voltage drop is represented by effective resistance of the current path ( $R_{DS}$ ), shown in the Figure next, and the Drain current ( $I_D$ ) as:

$$V_{on} = R_{DS}I_D$$

It is in the range 3V to 6V, depending on devices ratings!

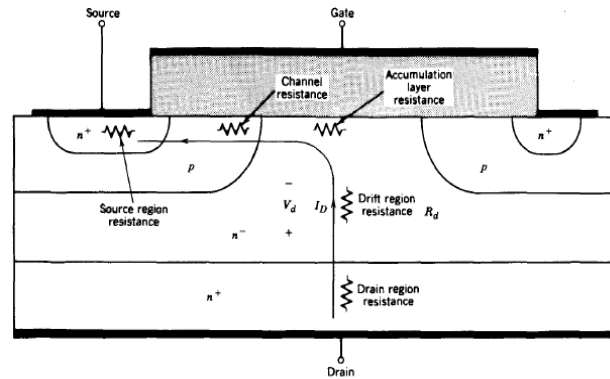

- ▶ In the **Ohmic region**, the Drain current ( $I_D$ ) is controlled by the external circuit connected to Drain and Source terminals. In this region, the device operates as a switch.
- ▶ The switching waveforms of a Power MOSFET implemented in a chopper circuit are illustrated below.

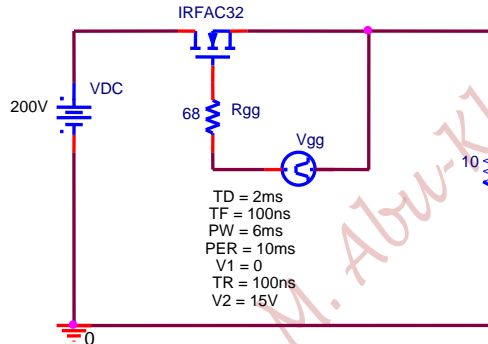

Dr. M. Abul-Khairzaman, BZU, Faw

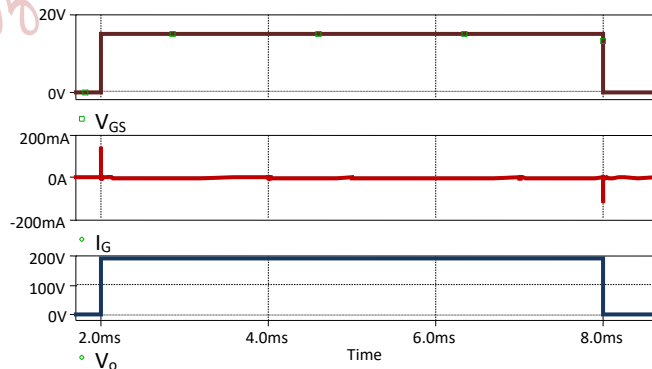

- ▶ Note that the **Breakdown voltage of the Gate-Source (Oxide) is less than 20V!**
- ▶ It is clear that only a charging or a discharging Gate current flows at transitions, due to the insulated Gate of the device. Studying the small signal model of the MOSFET, which is similar to that of IGBT, a topic to be introduced later, explains this fact.



## Small Signal Model of a Power MOSFET

The equivalent Small Signal Model of a Power MOSFET is shown in the Figure next.

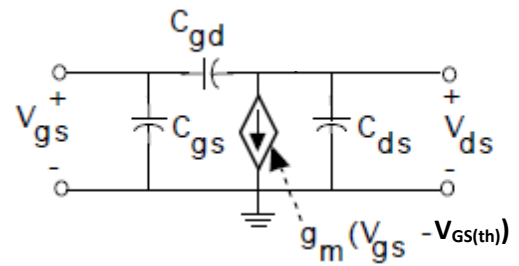

- The Drain current is dependent of the Gate-Source Voltage.
  - The value of the dependent current source depends on the device parameters and Gate-Source voltage.
  - The Gate-Source control circuit is responsible for charging/discharging the input capacitance ( $C_{iss} = C_{gs} + C_{gd}$ ) of the Power MOSFET. Hence, no need for a continuous Gate current during on-state.
  - An external **Gate resistor is needed to limit the charging/discharging currents and prevents Gate oscillations.**
- ▶ A Power MOSFET requires a Gate Drive to be switched from one state to another; a topic will be discussed later in the IGBT lecture.
  - ▶ A Power MOSFET has **high switching frequency capabilities**;  $f \sim 1\text{MHz}$  (faster than BJTs).
  - ▶ The power rating of a MOSFET is in the range of 1000V and 50A; e.g. 1000V and 38A, 1500V and 4A.

## Safe Operating Area (SOA) of a Power MOSFET

- A Power MOSFET has a Square **Safe Operating Area (SOA)**, as shown below, indicating that it is appropriate for switching a clamped inductive load without the need for snubbers.
- No distinction between the Forward Bias (FB) or Reverse Bias (RB) SOA, as both are Square. Noting that the MOSFET is Forward Biased when  $V_{GS} \geq 0$ , and is Reverse Biased when  $V_{GS} \leq 0$ .

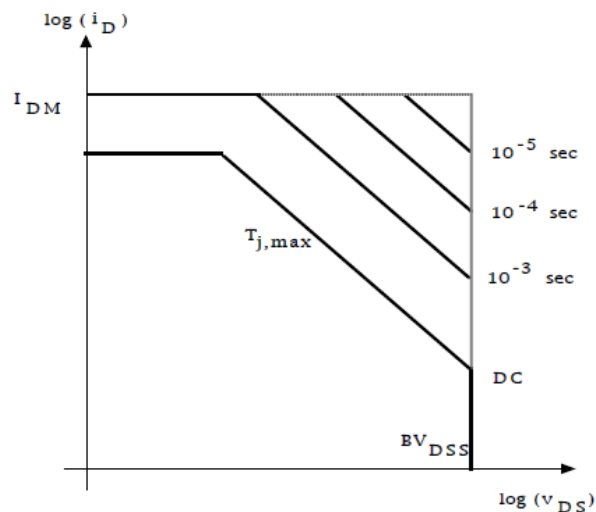

## D) Insulated Gate Bipolar Transistors (IGBTs)

- The symbol of an IGBT is shown in the Figure below; it has three terminals: the Gate (G), the Collector (C), and the Emitter (E).

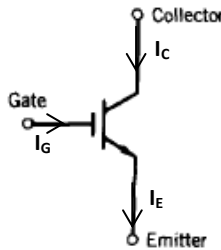

- The main types are: Punch-Through IGBTs, Non-Punch Through IGBTs, and recently Trench IGBTs.
- The Punch-Through layers' structure is shown below. The parasitic devices are also drawn dotted in the Figures. The parasitic Thyristor should never be triggered, otherwise the IGBT latches, and cannot be turned off via the Gate!

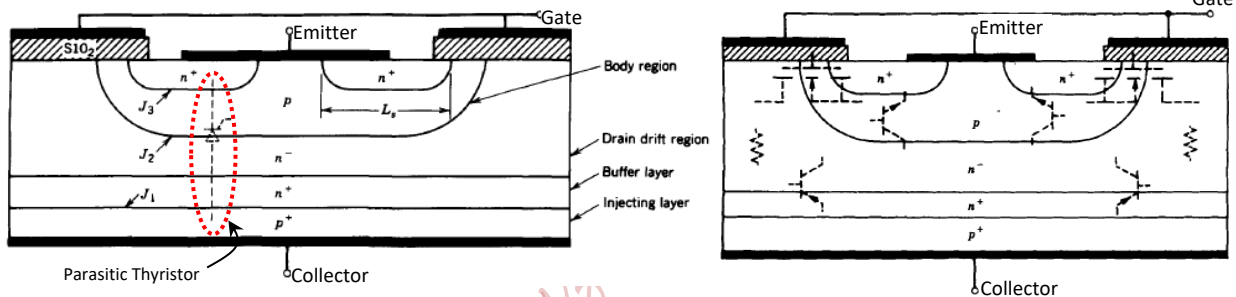

- The junction  $j_2$  is responsible for blocking a forward voltage, whilst  $j_1$  is unable to block any reverse voltage as there is no lightly doped layer next to the junction. In contrast, the Non-Punch Through IGBT has no  $n^+$  Buffer (layer) next to  $j_1$ , as shown in the Figure below, which enables the junction ( $j_1$ ) blocking reverse voltages; **Non-Punch Through IGBTs can block voltages in either polarities.**

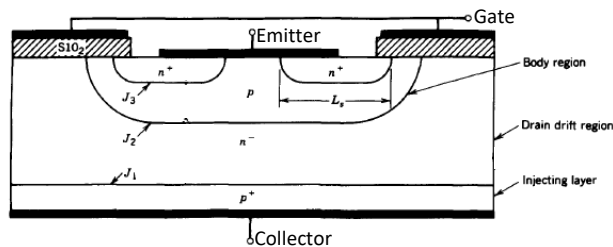

- The IGBT combines the best features of the Power MOSFET (fast switching and small gate control power), and the best features of the BJT (high current density with low on-state voltage drop).

## i-v Characteristics of IGBTs

The i-v (output) characteristic of an IGBT is shown in the Figure below.

- It has three distinctive modes: Cut-off (Blocking), Active and Saturation.
- When  $V_{GE} \geq V_{GE(th)}$  the channel is formed and the IGBT starts conduction.
- $V_{GE(th)}$ : is the minimum Gate–Emitter voltage required to form a channel and to turn-on the device.

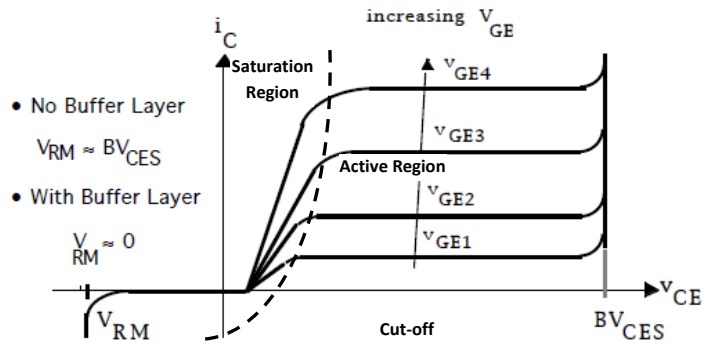

- $BV_{CES}$ : the Forward Breakdown Voltage
- IGBTs are **voltage controlled devices**, the Gate-Emitter voltage controls the IGBT mode.
- During conduction, when operating in Saturation region, the voltage drop across the IGBT ( $V_{CE(sat)}$ ) is in the range 2-5V depending on the IGBT power ratings. This voltage ( $V_{CE(sat)}$ ) is specified in the Datasheet of each IGBT and is represented as:

$$V_{CE(sat)} = V_{j1} + V_{drift} + I_C R_{channel}$$

where  $V_{j1}$  is the voltage drop across the pn-junction ( $\sim 0.65V$  to  $0.7V$  for Silicon).

$V_{drift}$  is the voltage drop due to the resistance of the drift region.

$I_C R_{channel}$  represents the voltage drop across the channel resistance.

### IGBT's Equivalent Circuit Models:

- A) A MOSFET driving the base of a BJT**  
Slow switching IGBT with low on-state voltage drop

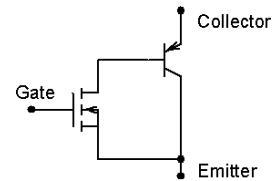

- B) A Diode in series with a MOSFET**  
Faster switching IGBT but with higher on-state voltage drop

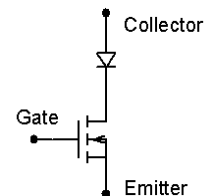

- The voltage rating of IGBTs is few kilo Volts ( $\sim 6.5kV$ ), and the current rating is up to  $\sim 4.5kA$ . However, these upper voltage and current limits are rarely to be found together in a particular IGBT; e.g. 3.3kV & 1.5kA, 1.7kV & 2.4kA, 6.5kV & 600A,...

## IGBT's Switching

IGBTs' switching is slower than that of MOSFETs, but faster than BJTs'; it could reach  $\sim 50\text{kHz}$  or even higher.

The IGBT is a **voltage-controlled device**, meaning that no continuous Gate current is needed to keep it in the on-state. However, charging/discharging Gate currents are needed to charge/discharge the input capacitance of the IGBT ( $C_{iss} = C_{ge} + C_{gc}$ ), as will be seen later in the small signal model of the device.

An IGBT turns on as fast as a Power MOSFET, but turns off as an open Base BJT having a tail current, which lasts for  $\sim 1\mu\text{s}$ , as clearly seen, though not to scale, in the switching waveforms below for an IGBT implemented in a chopper circuit.

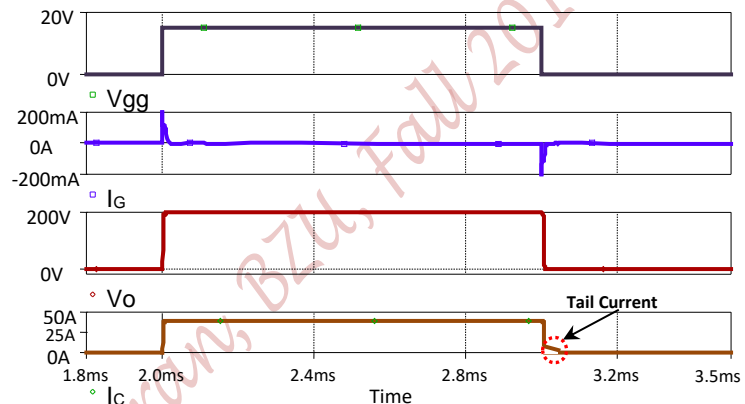
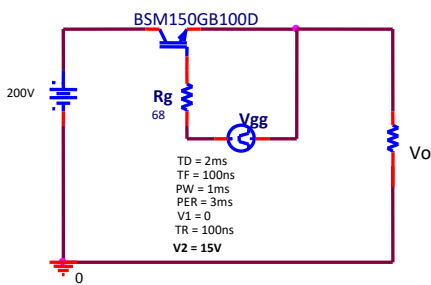

Note that, the Breakdown voltage of the Gate-Emitter (i.e. the Silicon Oxide) is less than 20V.

## A Small Signal Model of an IGBT

The model helps understanding why only charging/discharging currents are needed to switch the IGBT; to charge the input capacitance ( $C_{iss} = C_{ge} + C_{gc}$ ) via the gate resistance ( $R_g$ ).  **$R_g$  is an added gate**

**resistor, which is needed to limit charging/discharging rate to stabilize the gate circuit by damping probable oscillations.**

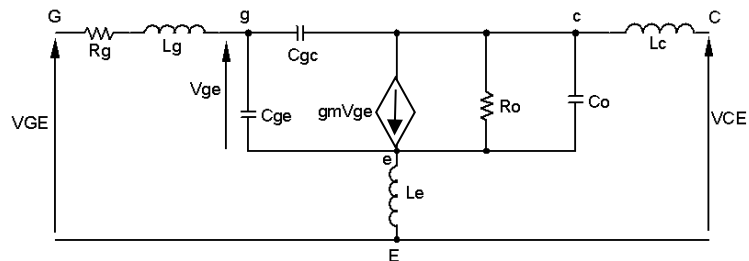

The inductors in the model are stray inductances at the IGBT terminals.

The stray inductance in the Gate-Emitter circuit can be minimized by twisting the gate and the low power emitter conductors together (using a twisted pair of conductors), and also using short conductors.

### Functions of an IGBT Gate Drive

IGBTs need Gate Drives to be switched from one mode to another. The **functions of the Gate Drive** are:

1. Isolating the control circuit from the power circuit
2. Supplying/sinking the required gate current to charge/discharge the IGBT's input capacitance
3. Level shifting to the Gate-Emitter voltage, which is necessary when the Emitter is floating; e.g. half bridge!

The Gate Drives are characterized by their sink/supply current and operating voltages.

Examples of IGBT Gate Drives are **L6384E** (shown in the Figure next), HCPL-3120 ....

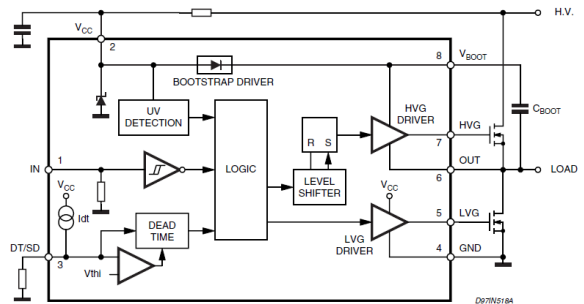

### Safe Operating Areas (SOA)

An IGBT has a Forward Bias Safe Operating Area (FBSOA) as shown in the Figure next, which makes it appropriate for switching clamped inductive load.

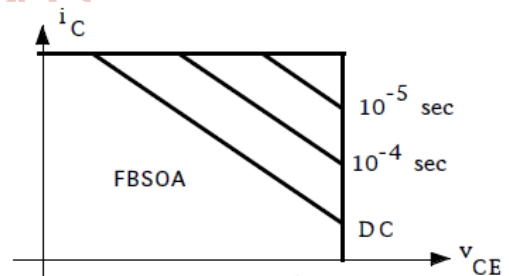

During Reverse Bias, manufacturers specify the maximum rate of increase of re-applied the Collector-Emitter voltage in order to avoid latch up of the intrinsic Thyristor of the IGBT and to avoid loss of control. These specifications are provided in a chart called Reverse Bias Safe Operating Area (RBSOA), shown next.

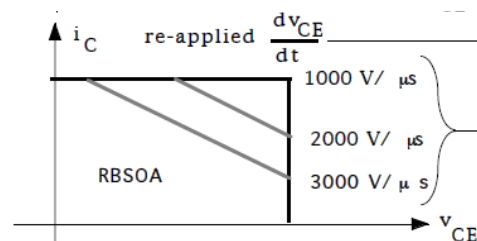

### IGBT Samples



Discrete IGBTs



Module IGBTs



Press Pack IGBTs

## Types of Power Electronic Circuits

1. Diode Rectifiers: Convert AC to fixed DC
2. Controlled Rectifiers or AC to DC converters: Convert AC to adjustable DC
3. AC Voltage Controllers: Convert AC to adjustable AC (voltage and/or frequency)
4. DC to DC converters or DC Choppers: Convert DC to adjustable DC
5. DC to AC converters or Inverters: Convert DC to AC (adjustable voltage and/or frequency)
6. Static Switches: Connect or Disconnect loads

### 1. Diode Rectifiers

A full-wave Diode rectifier with a center-tapped transformer and its waveforms are shown below.

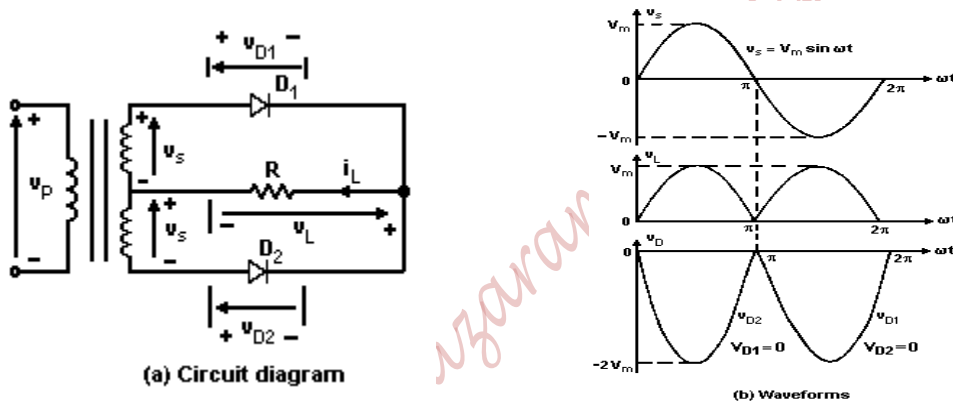

The AC voltage is converted to a fixed DC voltage with an AC ripple.

### 2. Controlled Rectifiers: AC to DC Converters

The average output voltage can be controlled by varying the conduction time of Thyristor (by varying the firing or delay angle), as seen in the half wave controlled rectifier below.

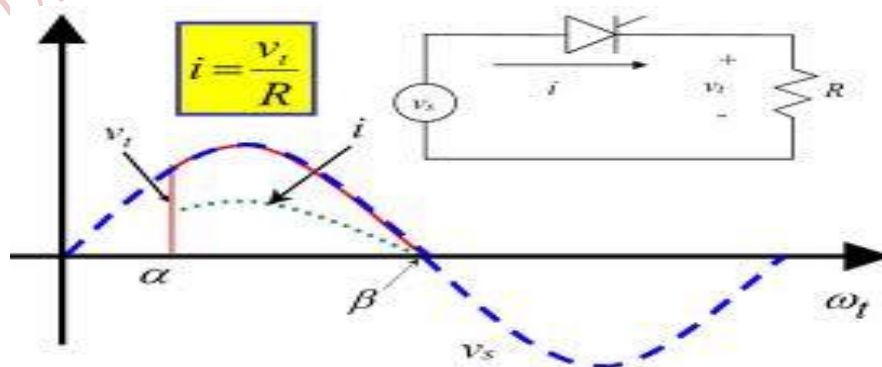

### 3. AC Voltage Controllers: AC to AC Converters

The Light Dimmer shown below is a typical example. The rms value of the output voltage is a variable AC controlled by of the TRIAC via the potentiometer (100k).

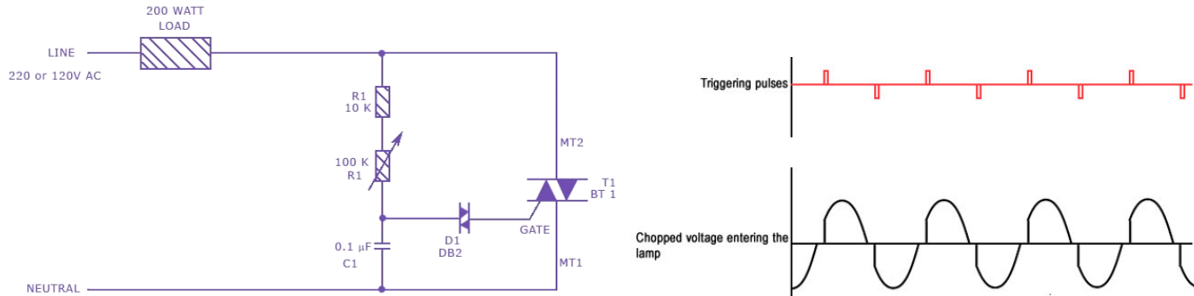

### 4. Choppers: DC to DC Converters

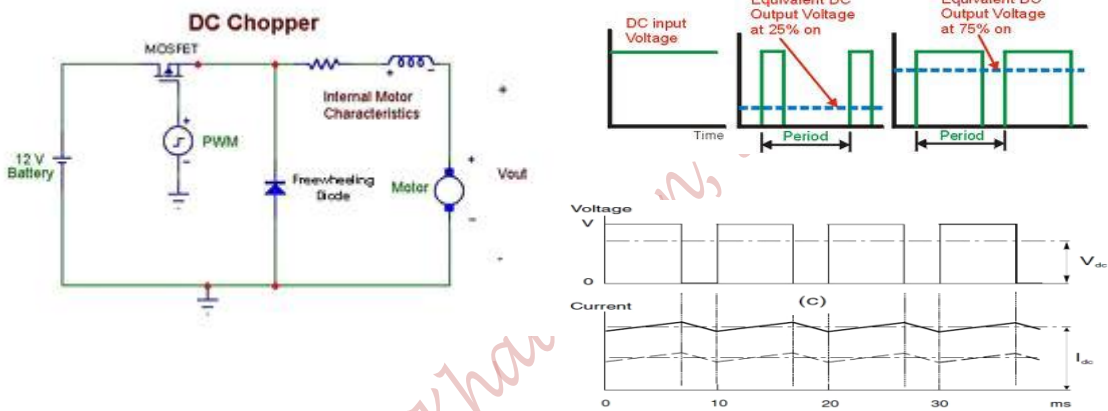

The on-time of the switch is:

$$t_{on} = \rho T$$

where  $\rho$  is the duty cycle, and  $T$  is the whole cycle. The average output voltage ( $V_{AVG}$ ) is controlled by varying the conduction time (duty cycle) of the MOSFET ( $t_{on}$ ).

$$V_{AVG} = \rho V_{DC}$$

## 5. Inverters: DC to AC Converters

Operating a full bridge in square wave mode yields:

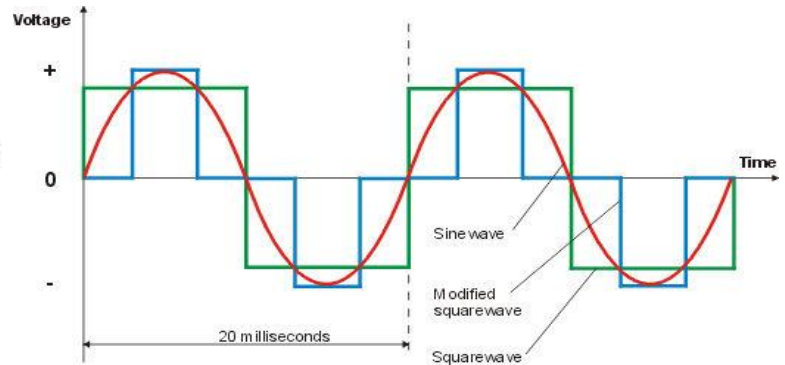
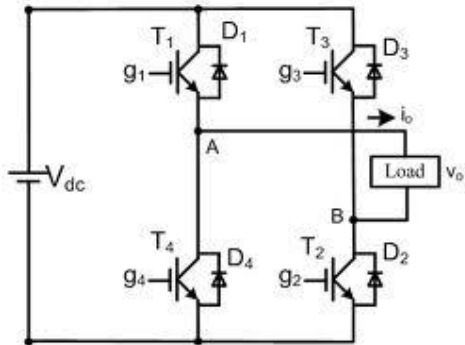

Remember that the square wave has infinite sinusoidal voltage harmonics.

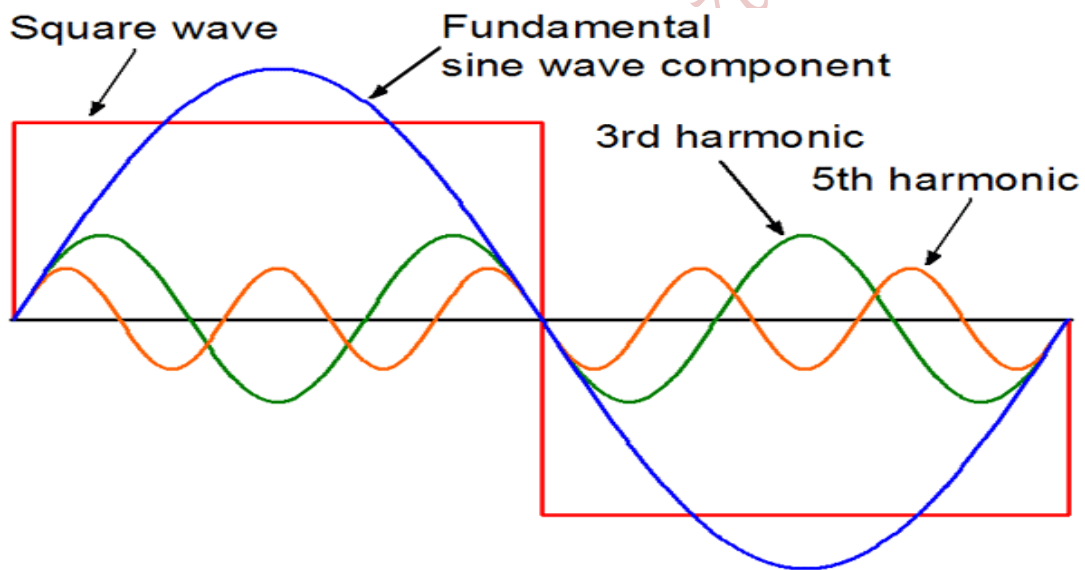

## 6. Static Switches:

The power electronic devices can be operated as static switches to connect or disconnect loads instead of using contactors. The source can be either AC or DC, and the switches are called AC static switches or DC static switches, respectively.



# Part II: Uncontrolled AC-to-DC Converters (Rectifiers)

**Rectifiers** are power electronic circuits designed to convert an AC voltage (or current) into a DC voltage (or current). The output of these rectifiers consists of **an average voltage** or current (a DC component), **plus** other (undesirable) AC components called **harmonics**.

## Diode Circuits and Rectifiers:

### 1) Diodes with RC Load

- If the switch  $S_1$ , in the DC circuit shown in the Figure next, is closed at  $t = 0s$ , assuming an ideal diode and applying KVL yield:

$$V_s = v_R + v_C$$

$$V_s = Ri(t) + \frac{1}{C} \int i(t) dt + v_C(0);$$

Assume that  $v_C(0) = 0$

- Solving the equation, by Laplace Transformation, yields the capacitor voltage and current as:

$$v_C(t) = V_s \left(1 - e^{-\frac{t}{\tau}}\right)$$

$$i(t) = \frac{V_s}{R} e^{-\frac{t}{\tau}}$$

where,  $\tau = RC$  is the time constant.

- A plot of the capacitor's current and voltage are shown in the Figure next.
- The energy stored in the capacitor's electric field is given by:

$$E_c = \frac{1}{2} CV_C^2$$

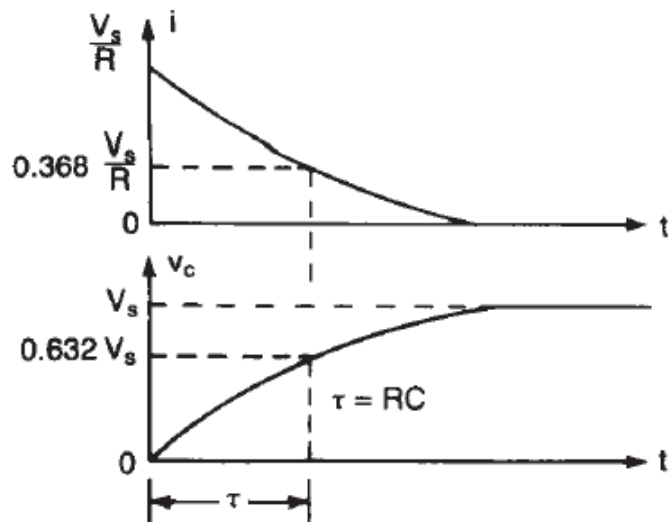
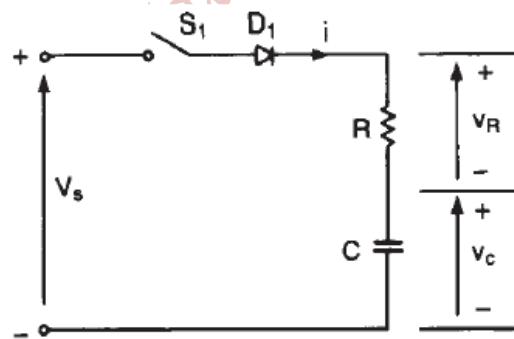

## 2) Diode Rectifiers with RL Load

- ◆ If the switch  $S_1$ , in the DC circuit shown in the Figure next, is closed at  $t = 0s$ , assuming an ideal diode and applying KVL yield:

$$V_s = v_R + L \frac{di(t)}{dt}$$

- ◆ The inductor current and voltage are:

$$i(t) = \frac{V_s}{R} \left(1 - e^{-\frac{t}{\tau}}\right)$$

$$v_L(t) = V_s e^{-\frac{t}{\tau}}$$

where,  $\tau = \frac{L}{R}$  is the time constant.

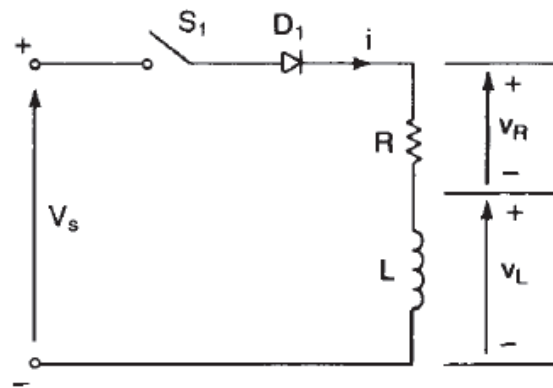

- ◆ A plot of the inductor's voltage and current are shown in the Figure next.

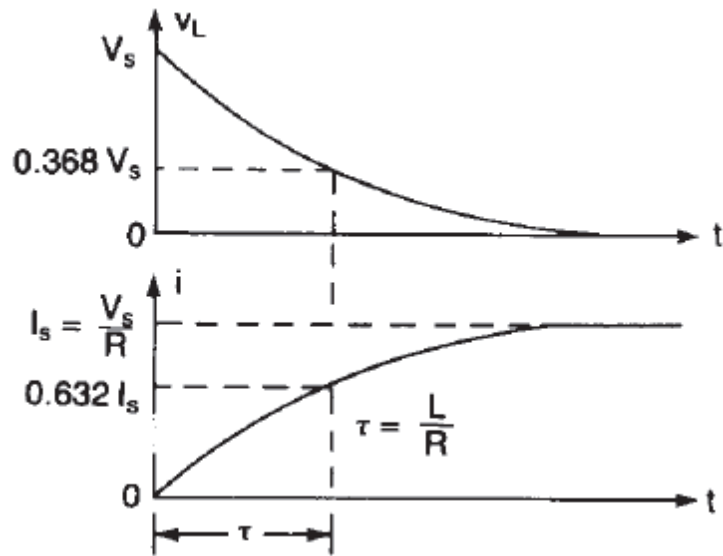

- ◆ The energy stored in the inductor's magnetic field is:

$$E_L = \frac{1}{2} LI^2$$

## Freewheeling Diode for an RL Load

The steady state current in the inductor is:

$$I_s = \frac{V_s}{R}$$

An attempt to open the switch ( $S_1$ ) will result in transferring the energy stored in the inductor ( $E_L = \frac{1}{2}LI^2$ ) into a high voltage across the switch and the diode. This energy will be dissipated in the form of a spark, which may damage the circuit components. This situation is overcome by connecting a **Freewheeling Diode** ( $D_m$ ) across the load, as illustrated in the Figure below. This diode,  $D_m$ , provides an alternative path for the current when the switch is off.

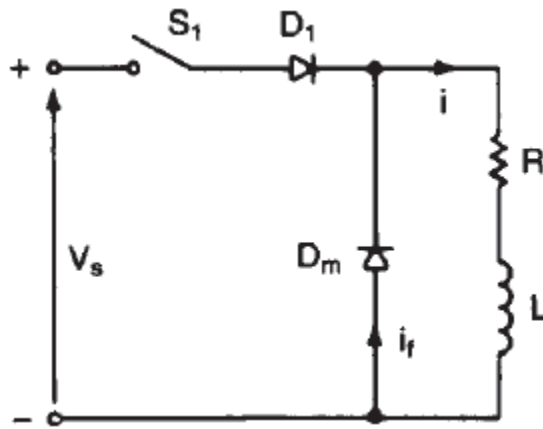

### Circuit's Operation:

There are two modes of operation as illustrated below:

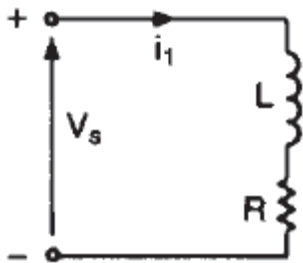

**Mode I:** The switch is on ( $D_m$  is off)

$$i_1(t) = \frac{V_s}{R} \left( 1 - e^{-\frac{t}{\tau}} \right)$$

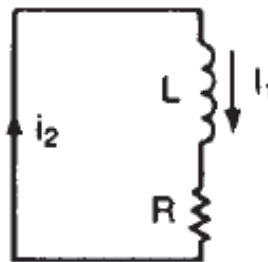

**Mode II:** The switch is off ( $D_m$  is on)

$$i_2(t) = I_1 e^{-\frac{t}{\tau}}$$

where,  $I_1$  is the inductor's initial current when  $S_1$  is opened.

A plot of these currents is shown in the Figure below. If the current is allowed to decay to zero,  $t_2$  must be  $\gg \frac{L}{R}$ .

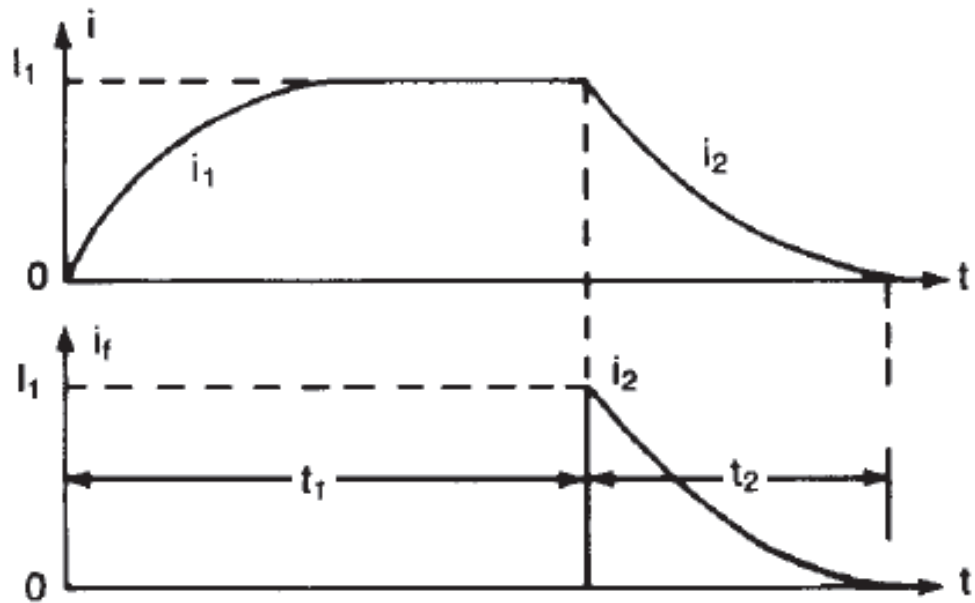

Dr. M. Abu-Khair

## Single Phase Half Wave Rectifiers

- Recall that, a **Rectifier** is a circuit that converts an AC voltage into a unidirectional voltage.
- A Single Phase Half Wave Rectifier supplying a resistive load is shown in the Figure below.

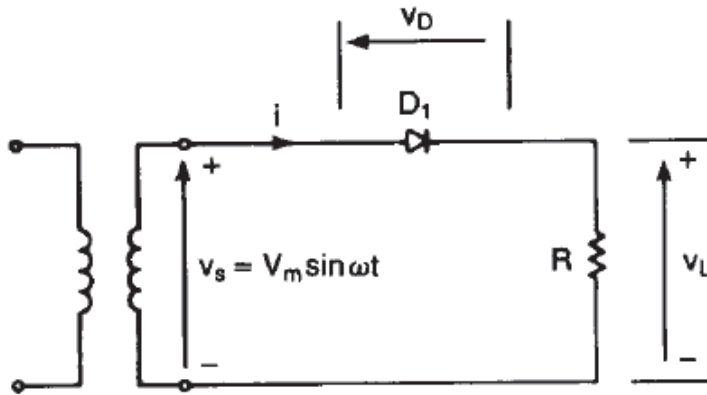

- The corresponding voltage and current waveforms are shown in the Figure next.
- The **average output voltage** is:

$$V_{dc} = \frac{1}{T} \int_0^{T/2} V_m \sin \omega t \, dt$$

$$V_{dc} = \frac{-V_m}{\omega T} \left( \cos \frac{\omega T}{2} - 1 \right)$$

where,  $\omega = 2\pi f$  and  $f = \frac{1}{T}$ , thus

$$V_{dc} = \frac{-V_m}{2\pi} (\cos \pi - 1)$$

$$V_{dc} = \frac{V_m}{\pi} = 0.318 V_m$$

- Note that,  $\omega = 2\pi f$  is the angular radian frequency in rad/s.

- The Peak-Inverse-Voltage (PIV) is the maximum reverse voltage applied across the diode during a blocking state and, in this case, is  $V_m$ .

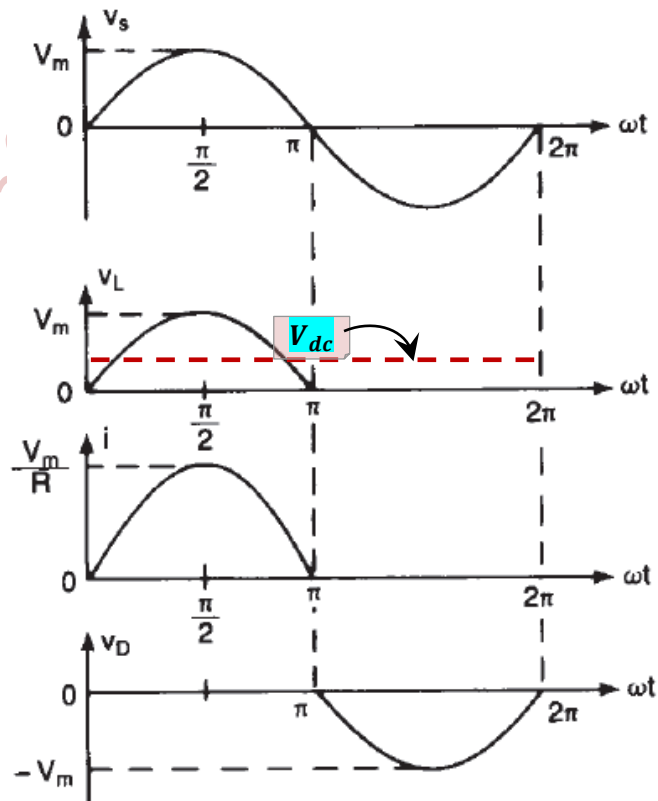

## Performance Parameters

These parameters are used to characterize a power electronic converter, and some of these are:

- ◆ The average value of the output voltage is:

$$V_{dc} = \frac{1}{T} \int_0^T v(t) dt$$

- ◆ The average value of the output current is:

$$I_{dc} = \frac{1}{T} \int_0^T i(t) dt$$

- ◆ The output DC power is:

$$P_{dc} = I_{dc} V_{dc}$$

- ◆ The Root-Mean-Square of the output voltage is:

$$V_{rms} = \sqrt{\frac{1}{T} \int_0^T (v(t))^2 dt}$$

- ◆ The Root-Mean-Square of the output current is:

$$I_{rms} = \sqrt{\frac{1}{T} \int_0^T (i(t))^2 dt}$$

- ◆ The output AC apparent power is:

$$P_{ac} = I_{rms} V_{rms}$$

- ◆ The **Rectification Efficiency** (or Ratio) of a rectifier is:

$$\eta = \frac{P_{dc}}{P_{ac}}$$

- ◆ The output voltage can be expressed as:

$$v_o = V_{dc} + v_{ac}$$

where,  $v_{ac}$  is the AC component of the output voltage; the ripple.

- ◆ The rms value of the AC component (the ripple) at the output is:

$$v_{ac}(rms) = \sqrt{(V_{rms})^2 - (V_{dc})^2}$$

- ◆ The **Form Factor (FF)** is a measure of the shape of the output voltage and is expressed as:

$$FF = \frac{V_{rms}}{V_{dc}}$$

- ◆ The **Ripple Factor (RF)** is expressed as:

$$RF = \frac{v_{ac}(rms)}{V_{dc}} = \sqrt{\frac{(V_{rms})^2}{(V_{dc})^2} - 1} = \sqrt{FF^2 - 1}$$

- ◆ The **Transformer Utilization Factor (TUF)** is expressed as:

$$TUF = \frac{P_{dc}}{V_s I_s}$$

where,  $V_s$  and  $I_s$  are the rms values of the transformer's secondary voltage and current, respectively.

- ◆ **Displacement Angle:**

Consider the waveforms shown in the Figure below,

where,  
 $i_{s1}$  is the  
 fundamental  
 component of  
 the Rectifier's  
 input current

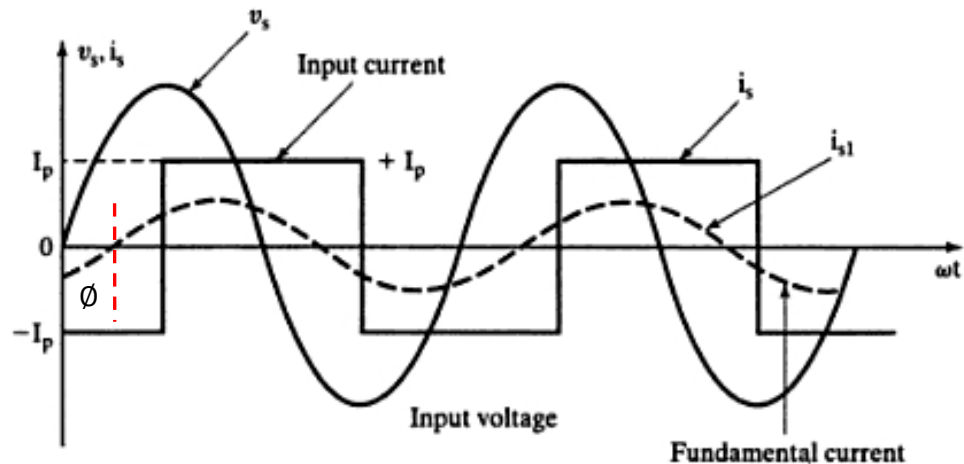

If  $\phi$  is the angle between the fundamental components of the input current and voltage, then  $\phi$  is called the **Displacement angle**.

- ◆ **Total Harmonic Distortion (THD) or Harmonic Factor (HF)** is expressed as:

$$THD = \sqrt{\frac{(I_s)^2 - (I_{s1})^2}{(I_{s1})^2}} = \sqrt{\frac{(I_s)^2}{(I_{s1})^2} - 1}$$

where  $I_s$  and  $I_{s1}$  are the rms values of the transformer's secondary current and its fundamental component, respectively.

- ◆ The input **Power Factor (PF)** is expressed as:

$$PF = \frac{V_s I_{s1} \cos \phi}{V_s I_s} = \frac{I_{s1}}{I_s} \cos \phi$$

Note that, for a purely sinusoidal transformer secondary current,  $I_s$  and  $I_{s1}$  are equal and, therefore,

$$PF = \cos \phi = DPF$$

- ◆ **Crest Factor (CF)** is expressed as:

$$CF = \frac{i_{s(peak)}}{I_s}$$

It is a useful factor for specifying the peak current rating of power devices.

- ◆ Note, for an ideal rectifier:

$$\eta = 100\%, FF = 100\%, RF = 0\%, TUF = 100\%, THD = 0\%, PF = DPF = 1$$

**Example:**

**For the Half-Wave Rectifier with resistive load, find:  $\eta$ ,  $FF$ ,  $RF$ ,  $PIV$  of the diode,  $TUF$  and  $CF$  of the input current.**

**Solution:**

The average output voltage is:

$$V_{dc} = \frac{1}{T} \int_0^{T/2} V_m \sin \omega t \, dt$$

$$V_{dc} = \frac{-V_m}{\omega T} \left( \cos \frac{\omega T}{2} - 1 \right)$$

since  $\omega = 2\pi f$  and  $f = \frac{1}{T}$  then,

$$V_{dc} = \frac{-V_m}{2\pi} (\cos \pi - 1)$$

$$V_{dc} = \frac{V_m}{\pi} = 0.318 V_m$$

The average output current is:

$$I_{dc} = \frac{V_{dc}}{R} = \frac{V_m}{\pi R} = \frac{0.318 V_m}{R}$$

The rms value of the output voltage is:

$$V_{rms} = \sqrt{\frac{1}{T} \int_0^{T/2} (V_m \sin \omega t)^2 \, dt} = \frac{V_m}{2}$$

The rms value of the output current is:

$$I_{rms} = \frac{V_m}{2R}$$

The output DC power is:

$$P_{dc} = \frac{(0.318 V_m)^2}{R}$$

The output AC apparent power is:

$$P_{ac} = \frac{(0.5 V_m)^2}{R}$$



- a) The rectification efficiency;  $\eta = \frac{P_{dc}}{P_{ac}} = \frac{(0.318 V_m)^2}{(0.5 V_m)^2} = 40.5\%$
- b) The Form Factor,  $FF = \frac{V_{rms}}{V_{dc}} = \frac{0.5 V_m}{0.318 V_m} = 1.57$  or 157%
- c) The Ripple Factor,  $RF = \frac{v_{ac(rms)}}{V_{dc}} = \sqrt{FF^2 - 1} = \sqrt{(1.57)^2 - 1} = 1.21$  or 121%
- d) The Peak Inverse Voltage (PIV) is  $V_m$ .
- e) The rms voltage of the transformer secondary is:

$$V_s = \frac{V_m}{\sqrt{2}}$$

The rms value of the transformer secondary current is the same as that of the load's; i.e.,

$$I_s = \frac{V_m}{2R}$$

The Volt-Ampere rating of the transformer is:

$$VA = V_s I_s = \frac{V_m}{\sqrt{2}} \frac{V_m}{2R} = \frac{0.707 V_m 0.5 V_m}{R}$$

Transformer Utilization Factor is:

$$TUF = \frac{P_{dc}}{V_s I_s} = \frac{(0.318 V_m)^2 / R}{0.707 V_m 0.5 V_m / R} = 0.286$$
 or 28.6%

The Transformer has to be  $\frac{1}{TUF}$  (3.496) times larger than that is needed to deliver the same power from a pure AC source.

The transformer carries a DC current, which results in DC saturation problem of the core.

- f)  $i_{s(peak)} = \frac{V_m}{R}$  and  $I_s = \frac{V_m}{2R}$ , then the Crest Factor is,

$$CF = \frac{i_{s(peak)}}{I_s} = \frac{V_m/R}{V_m/2R} = 2$$

### Single-Phase Half-Wave Rectifier with an RL Load

Consider the circuit shown in the Figure below,

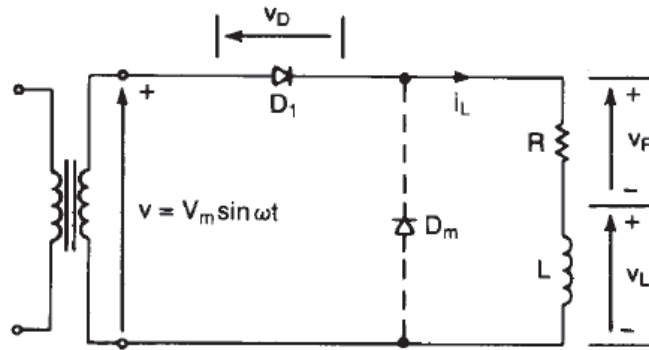

- Due to the inductive load, the conduction period of  $D_1$  extends beyond  $180^\circ$ , until the current becomes zero at  $\omega t = \pi + \theta$ , as shown in the waveforms next.

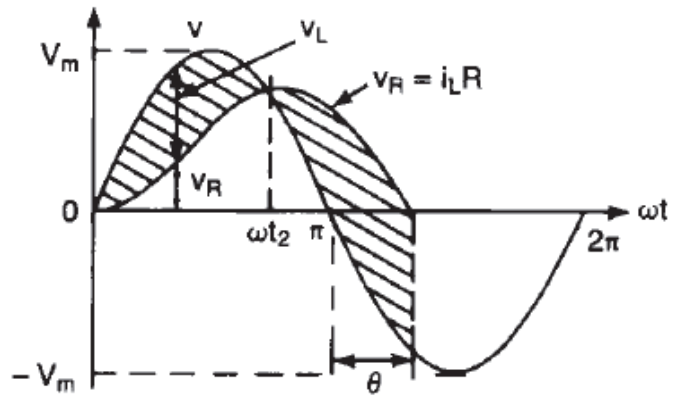

- The average voltage across the inductor is zero; i.e., **Area 'A' = Area 'B'**

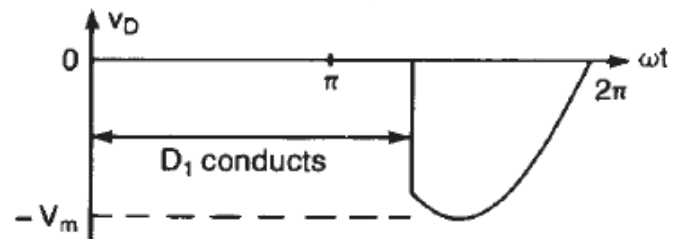

- Applying KVL yields,

$$V_m \sin \omega t = v_R + L \frac{di_L}{dt}$$

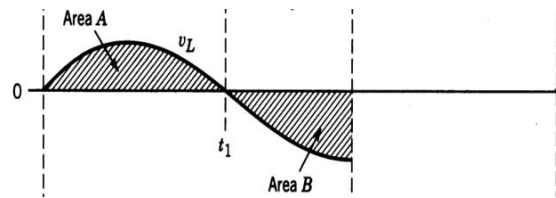

- Solving the differential equation yields:

$$i_L(t) = \frac{-V_m}{\sqrt{R^2 + \omega^2 L^2}} \cos \theta e^{-\left(\frac{R}{L}\right)t} + \frac{V_m}{\sqrt{R^2 + \omega^2 L^2}} \cos(\omega t - \theta)$$

where,  $\theta = \tan^{-1} \frac{\omega L}{R}$

and,  $v_L(t) = L \frac{di_L(t)}{dt}$

- The average output voltage is:

$$V_{dc} = \frac{1}{2\pi} \int_0^{\pi+\theta} V_m \sin \omega t \, d\omega t$$

$$V_{dc} = \frac{-V_m}{2\pi} (\cos \omega t |_0^{\pi+\theta})$$

$$V_{dc} = \frac{V_m}{2\pi} (1 - \cos(\pi + \theta))$$

For any value of  $\theta$  greater than zero, the average output voltage is less than  $V_{dc} = \frac{V_m}{\pi}$

- The average load current is  $I_{dc} = \frac{V_{dc}}{R}$
- Note that, the output voltage is negative during the interval between ' $\pi'$ ' and ' $\pi + \theta'$ ', that's why the average voltage is less than that is obtained with a purely resistive load.

### Addition of the Freewheeling Diode

- $D_m$  prevents a negative voltage appearing across the load, therefore,  $V_{dc}$  increases and becomes as that of a resistive load.
- $D_1$  conducts during the positive half cycle of the supply voltage; (from  $\omega t = 0$  to  $\omega t = \pi$ ), at  $\omega t = \pi$  the current transfers to  $D_m$ .
- $D_m$  conducts in the interval from ' $\pi'$ ' to ' $\pi + \theta'$ '. The latter angle depends on the load time constant.

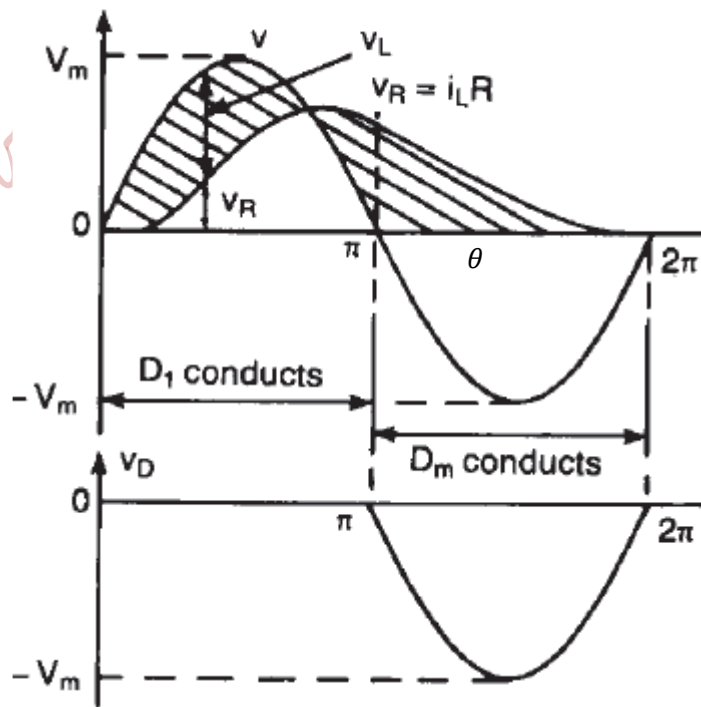

## Battery Charger

- ❖ If the output is connected to a battery, a rectifier can be used as a Battery Charger, as shown in the Figure below.

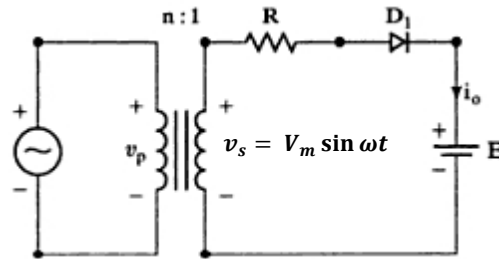

- ❖ When  $v_s > E$ , the diode ( $D_1$ ) conducts and the battery is charged.

- ❖  $\alpha$  can be found from:

$$V_m \sin \alpha = E$$

$$\alpha = \sin^{-1} \left( \frac{E}{V_m} \right)$$

- ❖ The diode is off when  $V_s < E$  at

$$\beta = \pi - \alpha$$

- ❖ The charging current is:

$$i_o = \frac{v_s - E}{R} = \frac{V_m \sin \omega t - E}{R}$$

which is valid for  $\alpha < \omega t < \beta$

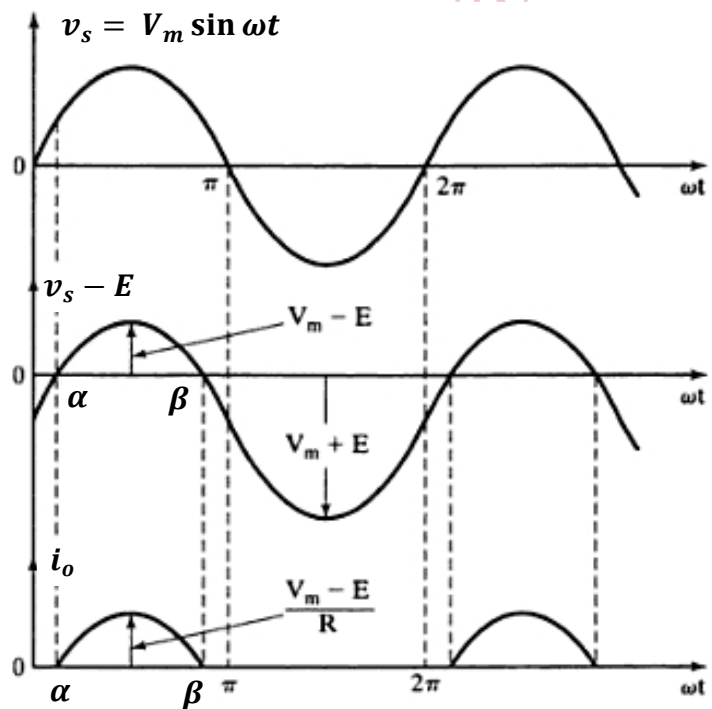

- ❖ Note that, the resistor 'R' limits the charging current.

## Single-Phase Full-Wave Rectifiers

### 1) Single-Phase Rectifier with Center-Tapped Transformer

- Each half of the transformer secondary with the associated diode acts as a half-wave rectifier.
- There is no DC current flowing in the transformer, hence no DC saturation problem of the transformer core.

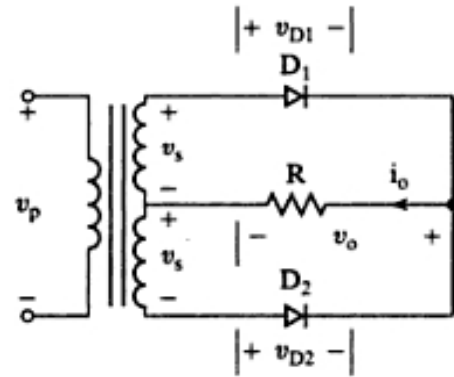

- The corresponding voltage waveforms are shown in the Figure next.
- The average output voltage is:

$$V_{dc} = \frac{2}{T} \int_0^{T/2} V_m \sin \omega t dt$$

$$V_{dc} = \frac{-2V_m}{\omega T} \left( \cos \frac{\omega T}{2} - 1 \right)$$

where,  $\omega = 2\pi f$  and  $f = \frac{1}{T}$ ; thus

$$V_{dc} = \frac{-V_m}{\pi} (\cos \pi - 1)$$

$$V_{dc} = \frac{2V_m}{\pi} = 0.6366 V_m$$

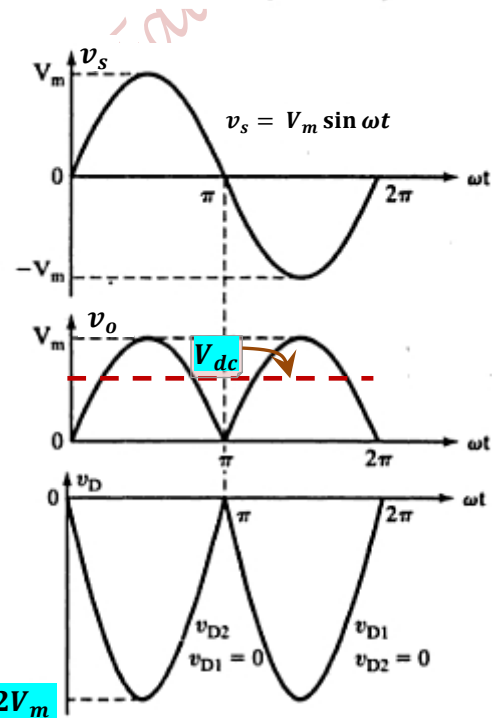

- The Peak-Inverse-Voltage (PIV) is the maximum reverse voltage across each diode and equals  $2V_m$ .
- To lower the PIV, use a Full-Wave Bridge Rectifier.

## 2) Single-Phase Full-Wave Bridge Rectifier

- It is commonly used in industrial applications.
- The circuit topology of the Full-Wave Bridge Rectifier is shown in the Figure next.
- The corresponding voltage and current waveforms are shown in the Figure next.
- The Peak-Inverse-Voltage is the maximum voltage across each diode and equals  $V_m$ .

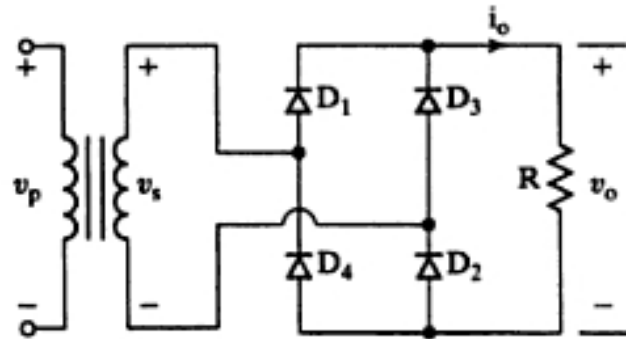

- Note that, two diodes are conducting at once, and the forward voltage drop is a problem in low voltage circuits; e.g. 5V-power supplies.
- Similarly, the average output voltage is:

$$V_{dc} = \frac{2}{T} \int_0^{T/2} V_m \sin \omega t \, dt$$

$$V_{dc} = \frac{-2V_m}{\omega T} \left( \cos \frac{\omega T}{2} - 1 \right)$$

$$V_{dc} = \frac{-V_m}{\pi} (\cos \pi - 1)$$

$$V_{dc} = \frac{2V_m}{\pi} = 0.6366 V_m$$

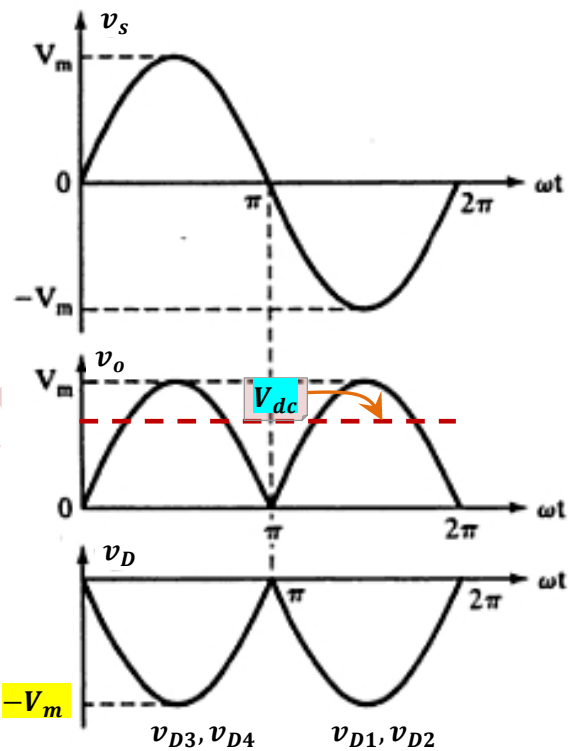

## Fourier Series Expansion (FSE)

Any periodic function,  $f(t)$ , can be represented as:

$$f(t) = F_{dc} + \sum_{n=1,2,\dots}^{\infty} (a_n \cos n\omega t + b_n \sin n\omega t)$$

where,  $F_{dc}$  is the average value, and is calculated as:

$$F_{dc} = \frac{1}{T} \int_0^T f(t) dt$$

If the period is  $2\pi$ ,  $\omega = 2\pi f$  and  $f = \frac{1}{T}$  then:

$$F_{dc} = \frac{1}{2\pi} \int_0^{2\pi} f(\omega t) d\omega t$$

The coefficient  $a_n$  is:

$$a_n = \frac{2}{T} \int_0^T f(t) \cos n\omega t dt ; \text{ for } n = 1, 2, 3 \dots$$

The coefficient  $b_n$  is:

$$b_n = \frac{2}{T} \int_0^T f(t) \sin n\omega t dt ; \text{ for } n = 1, 2, 3 \dots$$

The function  $f(t)$  can be rewritten in terms of a sine (or a cosine function) only as:

$$f(t) = F_{dc} + \sum_{n=1,2,\dots}^{\infty} c_n \sin(n\omega t + \phi_n)$$

where,

$$c_n = \sqrt{a_n^2 + b_n^2}, \text{ and } \phi_n = \tan^{-1} \left( \frac{a_n}{b_n} \right)$$

Note that:

- A function is even if:  $f(t) = f(-t)$ ; symmetry around y-axis
- A function is odd if:  $f(t) = -f(-t)$ ; symmetry around origin
- The product of two even functions is even.
- The product of two odd functions is even.
- The product of an even function and an odd function is odd.
- FSE of an even periodic function (with period  $2\pi$ ) does not have terms with sines;

$$f(t) = F_{dc} + \sum_{n=1,2,\dots}^{\infty} a_n \cos n\omega t;$$

where,  $b_n$  is zero for all  $n$

- FSE of an odd periodic function (with period  $2\pi$ ) has sine terms only;

$$f(t) = \sum_{n=1,2,\dots}^{\infty} b_n \sin n\omega t;$$

where, the average value and  $a_n$  are zero for all  $n$

**Example:**

Find the Fourier Series Expansion of the output voltage of the Single-Phase Full-Wave Rectifier.

**Solution:**

The output waveform is even with a frequency of  $2\omega$ ; no sine terms and all the cosine terms are multiples of the output waveform frequency; i.e.  $1(2\omega), 2(2\omega), 3(2\omega), \dots \Rightarrow 2\omega, 4\omega, 6\omega, \dots$

Therefore,

$$v_o(t) = V_{dc} + \sum_{n=2,4,6,\dots}^{\infty} (a_n \cos n\omega t + b_n \sin n\omega t)$$

The average output voltage is:

$$V_{dc} = \frac{1}{T} \int_0^T v_o(t) dt$$

$$V_{dc} = \frac{2}{2\pi} \int_0^{\pi} V_m \sin \omega t d\omega t = \frac{2V_m}{\pi}$$

The coefficients of cosine terms are:

$$a_n = \frac{2}{T} \int_0^T v_o(t) \cos n\omega t dt = \frac{2}{\pi} \int_0^{\pi} V_m \sin \omega t \cos n\omega t d\omega t$$

$$a_n = \frac{4V_m}{\pi} \left( \frac{-1}{(n-1)(n+1)} \right) \Big|_{n=2,4,6,\dots}$$

The coefficients of sine terms are:

$$b_n = \frac{2}{T} \int_0^T v_o(t) \sin n\omega t dt = \frac{2}{\pi} \int_0^{\pi} V_m \sin \omega t \sin n\omega t d\omega t = 0$$

Thus, the FSE of the output voltage is:

$$v_o(t) = \frac{2V_m}{\pi} - \frac{4V_m}{3\pi} \cos 2\omega t - \frac{4V_m}{15\pi} \cos 4\omega t - \frac{4V_m}{35\pi} \cos 6\omega t - \dots$$

The most dominant harmonic is the second harmonic.

**Exercise:**

Find the FSE of the output voltage of a Half-Wave Rectifier!



## Multi-Phase Star Rectifier

- Single phase Full-Wave Rectifiers are used in applications up to 5kW.
- The frequency of the fundamental component of harmonics is twice the source frequency.
- A filter is used to reduce the level of harmonics in the load; the size of the filter decreases with the increase in the frequency of harmonics.
- For higher powers, Multi-Phase ( $q$  –Phase) or Three-Phase Full-Wave Rectifiers are used.
- The frequency of the fundamental harmonic is ' $q$ ' times the source frequency ( $qf$ ), such that ' $q$ ' is the number of phases; the other harmonics' frequency are:  $n(qf)$ ;  $n = 2, 3, 4, \dots$
- The circuit topology of a Multi-Phase ( $q$  –Phase) Star Rectifier is shown in the Figure below.

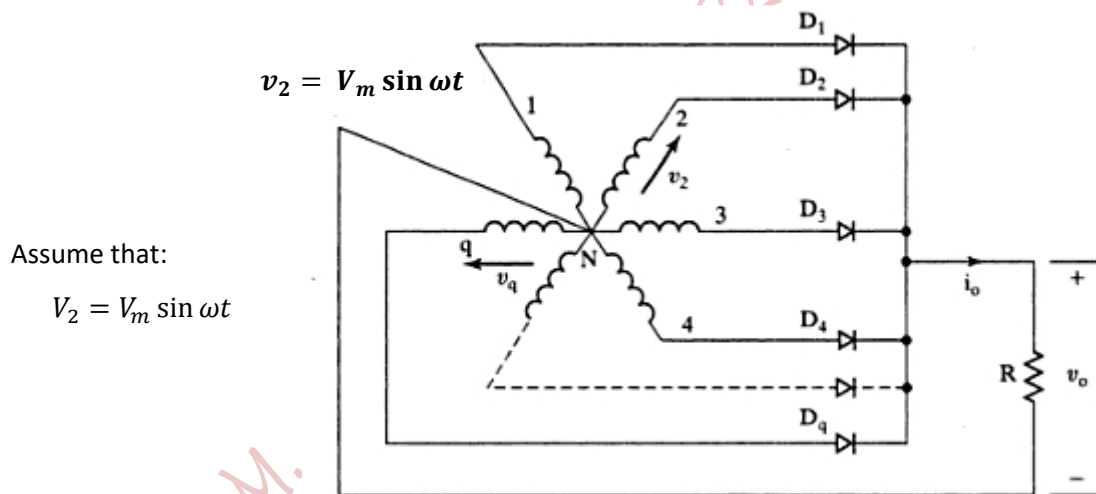

- The above circuit may be considered as  $q$  –Single Phase Half-Wave Rectifiers.

- Each phase voltage is shifted from the next or the previous phase by  $\frac{2\pi}{q}$ .
- Each diode conducts for  $\frac{2\pi}{q}$ ; the diode connected to the highest voltage in the circuit is conducting.
- The corresponding voltage waveforms for  $q=6$  are shown in the next Figure.

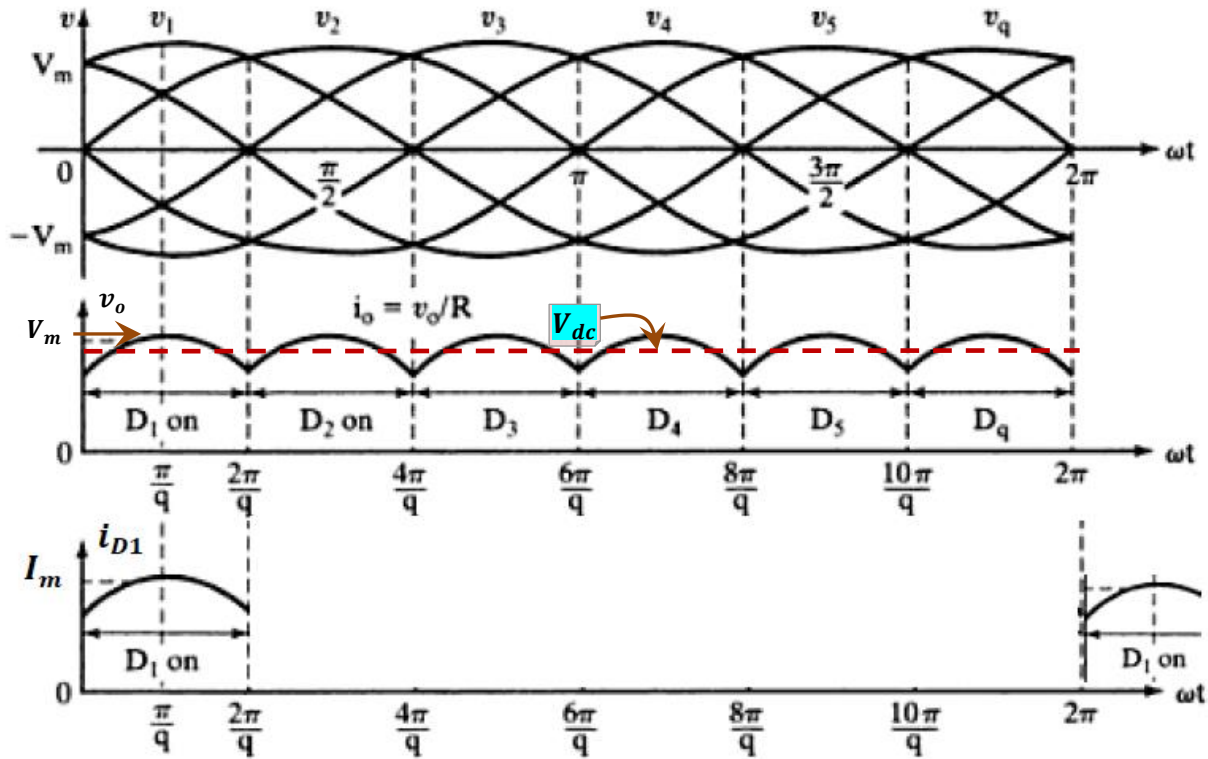

- Note that, the fundamental frequency of the AC ripple is ' $q$ ' times the source frequency; i. e.  $qf$ .
- The average output voltage can be calculated, by assuming a cosine function in the period from  $\frac{\pi}{q}$  to  $\frac{2\pi}{q}$ ,

as:

$$V_{dc} = \frac{1}{T} \int_0^T v_o(t) dt$$

$$V_{dc} = \frac{2q}{2\pi} \int_0^{\pi/q} V_m \cos \omega t d\omega t$$

....

$$V_{dc} = \frac{qV_m}{\pi} \sin \frac{\pi}{q}; \text{ valid for } q > 1$$

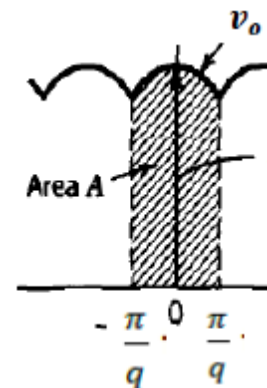

- Note that, if  $q = 6$ , then  $V_{dc} = \frac{3V_m}{\pi} = \frac{3V_{max}}{\pi}$

▣ The root-mean-square of the output voltage is:

$$V_{rms} = \sqrt{\frac{2q}{2\pi} \int_0^{\pi/q} (V_m)^2 \cos^2 \omega t d\omega t}$$

....

$$V_{rms} = V_m \sqrt{\frac{q}{2\pi} \left( \frac{\pi}{q} + \frac{1}{2} \sin \frac{2\pi}{q} \right)}$$

▣ The rms value of transformer secondary current or diode current is:

$$I_s = \sqrt{\frac{2}{2\pi} \int_0^{\pi/q} (I_m)^2 \cos^2 \omega t d\omega t}$$

where,  $I_m = \frac{V_m}{R}$

Fall 2017

### Example 2-10

A three-phase star rectifier has a purely resistive load with  $R$  ohms. Determine the (a) efficiency; (b) form factor; (c) ripple factor; (d) transformer utilization factor; (e) peak inverse voltage (PIV) of each diode; and (f) peak current through a diode if the rectifier delivers  $I_{dc} = 30$  A at a output voltage of  $V_{dc} = 140$  V.

**Solution** For a three-phase rectifier  $q = 3$  in Eqs. (2-69), (2-70), and (2-71).

(a) From Eq. (2-69),  $V_{dc} = 0.827V_m$  and  $I_{dc} = 0.827V_m/R$ . From Eq. (2-70),  $V_{rms} = 0.84068V_m$  and  $I_{rms} = 0.84068V_m/R$ . From Eq. (2-42),  $P_{dc} = (0.827V_m)^2/R$ , from Eq. (2-43),  $P_{ac} = (0.84068V_m)^2/R$ , and from Eq. (2-44), the efficiency,

$$\eta = \frac{(0.827V_m)^2}{(0.84068V_m)^2} = 96.77\%$$

(b) From Eq. (2-46), the form factor,  $FF = 0.84068/0.827 = 1.0165$  or  $101.65\%$ .

(c) From Eq. (2-48), the ripple factor,  $RF = \sqrt{1.0165^2 - 1} = 0.1824 = 18.24\%$ .

(d) From Eq. (2-57), the rms voltage of the transformer secondary,  $V_s = 0.707V_m$ . From Eq. (2-71), the rms current of the transformer secondary,

$$I_s = 0.4854I_m = \frac{0.4854V_m}{R}$$

The volt-ampere rating (VA) of the transformer is

$$VA = 3V_sI_s = 3 \times 0.707V_m \times \frac{0.4854V_m}{R}$$

From Eq. (2-49),

$$\text{TUF} = \frac{0.827^2}{3 \times 0.707 \times 0.4854} = 0.6643$$

(e) The peak inverse voltage of each diode is equal to the peak value of the secondary line-to-line voltage. Three-phase circuits are reviewed in Appendix A. The line-to-line voltage is  $\sqrt{3}$  times the phase voltage and thus  $\text{PIV} = \sqrt{3}V_m$ .

(f) The average current through each diode is

$$I_d = \frac{2}{2\pi} \int_0^{\pi/q} I_m \cos \omega t d(\omega t) = I_m \frac{1}{\pi} \sin \frac{\pi}{q} \quad (2-72)$$

For  $q = 3$ ,  $I_d = 0.2757I_m$ . The average current through each diode is  $I_d = 30/3 = 10$  A and this gives the peak current as  $I_m = 10/0.2757 = 36.27$  A.

Study other examples in Rashid's book!

Dr. M. Abu-Khairzaman, BZU, Faw

### Three-Phase Full-Wave Bridge Rectifier

- It is commonly used in power applications.
- The circuit topology of a Three-Phase Bridge Rectifier is shown in the Figure below.

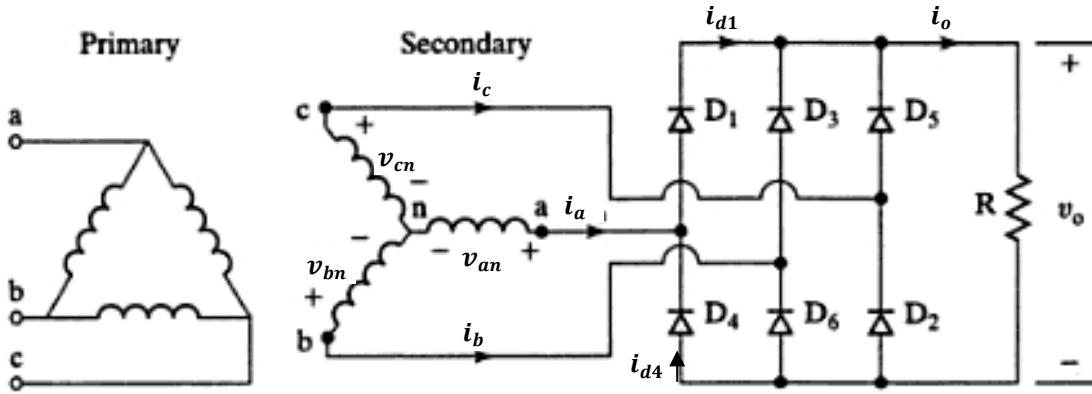

- Note the conventional numbering sequence of the diodes shown in the above Figure!
- This rectifier is equivalent to two half wave three-phase rectifiers connected as shown in the Figure below.

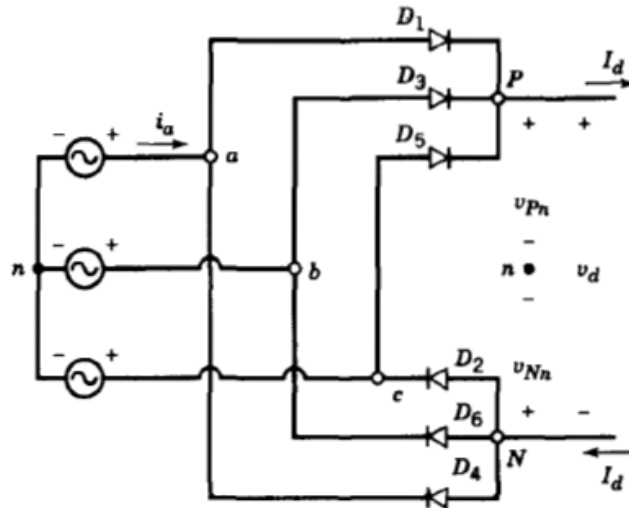

- The pair of diodes connected between the pair of supply voltages having the highest amount of instantaneous line-to-line voltage will be conducting, as shown in the waveforms of the Figure below.
- The diodes' conduction sequence is:  $D_1D_2, D_2D_3, D_3D_4, D_4D_5, D_5D_6, D_6D_1, D_1D_2, D_2D_3, \dots$
- Each diode conducts for  $120^\circ$  (or  $\frac{2\pi}{3}$ )!

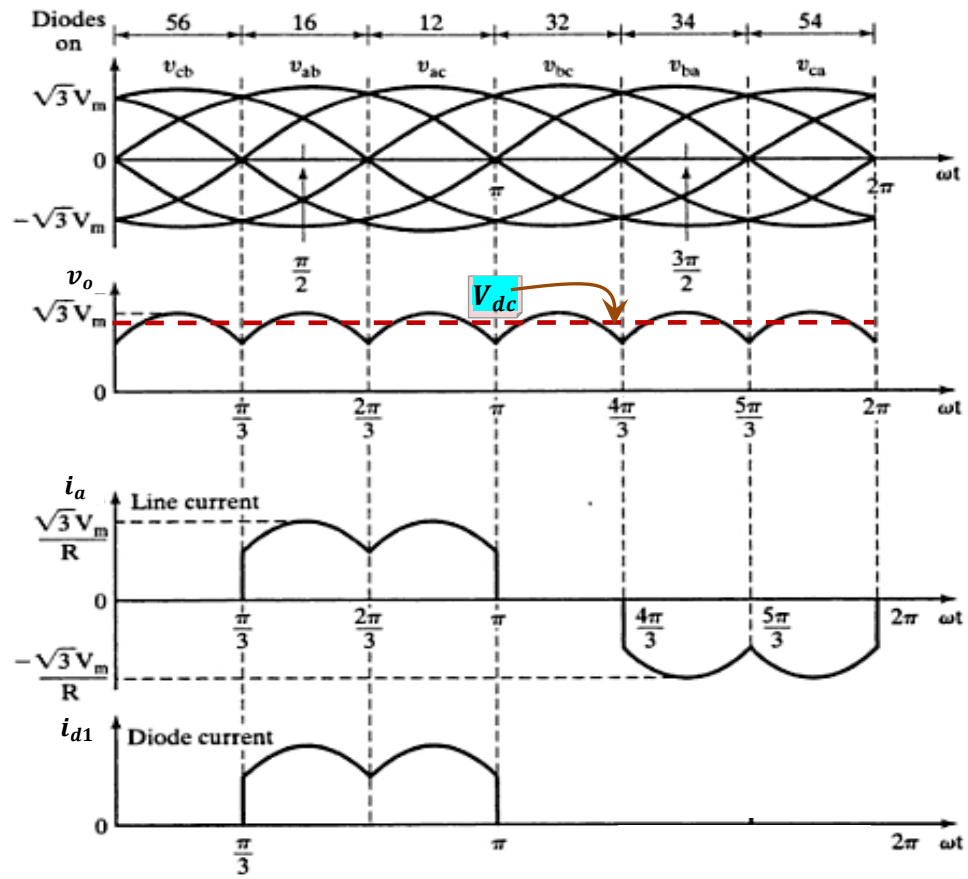

☐ Note that:

$$i_a = i_{d1} - i_{d4}$$

☐ The average output voltage can be calculated, also by assuming a cosine function in the period from 0 to  $\frac{\pi}{3}$ , as:

$$V_{dc} = \frac{1}{T} \int_0^T v_o(t) dt$$

$$V_{dc} = \frac{2(6)}{2\pi} \int_0^{\pi/6} \sqrt{3}V_m \cos \omega t d\omega t$$

....

$$V_{dc} = \frac{3\sqrt{3}V_m}{\pi} = 1.654V_m$$

☐ Note that, also  $V_{dc} = \frac{3V_{max}}{\pi}$ ; here  $V_{max} = \sqrt{3}V_m$

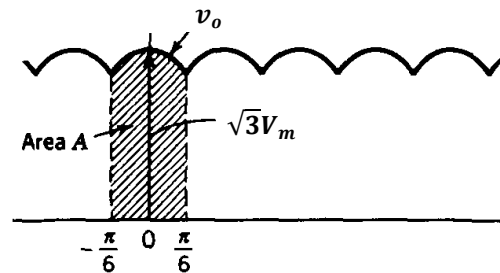

- ▣ The root-mean-square of the output voltage is:

$$V_{rms} = \sqrt{\frac{2(6)}{2\pi} \int_0^{\pi/6} (\sqrt{3}V_m)^2 \cos^2 \omega t d\omega t}$$

....

$$V_{rms} = V_m \sqrt{\left(\frac{3}{2} + \frac{9\sqrt{3}}{4\pi}\right)} = 1.6554V_m$$

- ▣ The rms value of transformer secondary current or diode current is:

$$I_s = \sqrt{\frac{8}{2\pi} \int_0^{\pi/6} (I_m)^2 \cos^2 \omega t d\omega t}$$

where,  $I_m = \frac{\sqrt{3}V_m}{R}$

....

$$I_s = I_m \sqrt{\frac{2}{\pi} \left(\frac{\pi}{6} + \frac{1}{2} \sin \frac{2\pi}{6}\right)}$$

$$I_s = 0.7804I_m$$

Study the examples in Rashid's book!

Dr. M. Abu-Khairzaman, BZU, Fall 2017

### Example 2-12

A three-phase bridge rectifier has a purely resistive load of  $R$ . Determine the (a) efficiency; (b) form factor; (c) ripple factor; (d) transformer utilization factor; (e) peak inverse (or reverse) voltage (PIV) of each diode; and (f) peak current through a diode. The rectifier delivers  $I_{dc} = 60$  A at an output voltage of  $V_{dc} = 280.7$  V and the frequency of the source is 60 Hz.

**Solution** (a) From Eq. (2-77),  $V_{dc} = 1.6542V_m$  and  $I_{dc} = 1.6542V_m/R$ . From Eq. (2-78),  $V_{rms} = 1.6554V_m$  and  $I_{rms} = 1.6554V_m/R$ . From Eq. (2-42),  $P_{dc} = (1.6542V_m)^2/R$ , from Eq. (2-43),  $P_{ac} = (1.6554V_m)^2/R$ , and from Eq. (2-44) the efficiency,

$$\eta = \frac{(1.6542V_m)^2}{(1.6554V_m)^2} = 99.86\%$$

(b) From Eq. (2-46), the form factor,  $FF = 1.6554/1.6542 = 1.0007 = 100.07\%$ .

(c) From Eq. (2-48), the ripple factor,  $RF = \sqrt{1.0007^2 - 1} = 0.0374 = 3.74\%$ .

(d) From Eq. (2-57), the rms voltage of the transformer secondary,  $V_s = 0.707V_m$ .

From Eq. (2-80), the rms current of the transformer secondary,

$$I_s = 0.7804I_m = 0.7804 \times \sqrt{3} \frac{V_m}{R}$$

The volt-ampere rating of the transformer,

$$VA = 3V_sI_s = 3 \times 0.707V_m \times 0.7804 \times \sqrt{3} \frac{V_m}{R}$$

From Eq. (2-49),

$$TUF = \frac{1.6542^2}{3 \times \sqrt{3} \times 0.707 \times 0.7804} = 0.9545$$

(e) From Eq. (2-77), the peak line-neutral voltage is  $V_m = 280.7/1.6542 = 169.7$  V. The peak inverse voltage of each diode is equal to the peak value of the secondary line-to-line voltage,  $PIV = \sqrt{3} V_m = \sqrt{3} \times 169.7 = 293.9$  V.

(f) The average current through each diode is

$$I_d = \frac{4}{2\pi} \int_0^{\pi/6} I_m \cos \omega t d(\omega t) = I_m \frac{2}{\pi} \sin \frac{\pi}{6} = 0.3184I_m$$

The average current through each diode is  $I_d = 60/3 = 20$  A and the peak current is  $I_m = 20/0.3184 = 62.81$  A.

*Note.* This rectifier has improved performances considerably compared to that of the multiphase rectifier in Fig. 2-17 with six pulses.



## Rectifier Circuit Design

- ✓ The output of rectifiers contains harmonics; i.e. DC plus an AC ripple. To reduce the AC ripple at the output, DC filters (low-pass filters) are used.
- ✓ There are three main types of DC filters:

### 1. Capacitor Smoothing (C-type)

A capacitor is connected across the output of the rectifier and load.

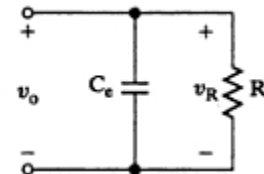

### 2. Inductor Smoothing (L-type)

An inductor is connected in series between the output of the rectifier and load.

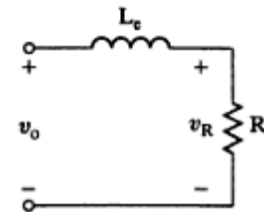

### 3. Combination of Inductors and Capacitors (LC-type)

An inductor is connected in series with the rectifier output and a capacitor is connected in parallel with the load.

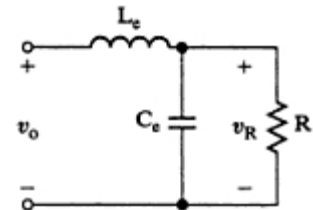

- ✓ Due to rectification action, the input current contains harmonics, therefore, AC filters (low-pass filters) are needed to eliminate some harmonics from the mains (Utility grid); AC supply, as shown in the Figure below.

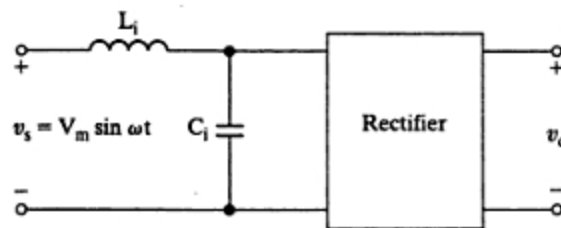

# 1. Capacitor Smoothing

Consider the Full-Wave Rectifier with the Center-Tapped Transformer, shown in the Figure below.

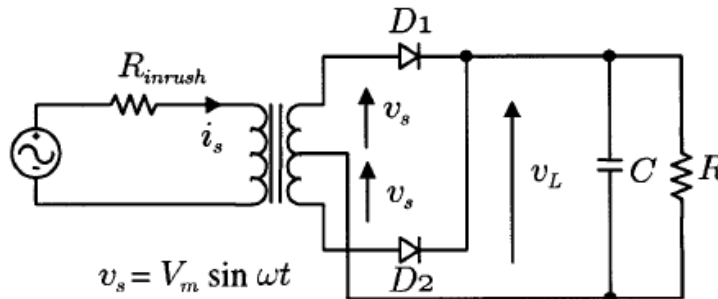

- ◆ In period 'A', of the waveforms of the Figure below, two diodes are conducting and the load voltage follows the supply voltage; the capacitor charges.

- ◆ In period 'B', the diodes do not conduct and the load current is supplied from the capacitor.

- ◆ Normally, the time constant 'RC' is much greater than the half supply period (10ms for 50Hz source), so the fall in the load voltage is not great.

- ◆ Period 'A' is between  $\omega t = \theta_1$ , where conduction starts, and  $\omega t = \theta_2$ , where the conduction ceases.  $\theta_1$  may be about  $30^\circ$  preceding the peak of the sine wave, and  $\theta_2$  is a few degrees past the peak of the sine wave.

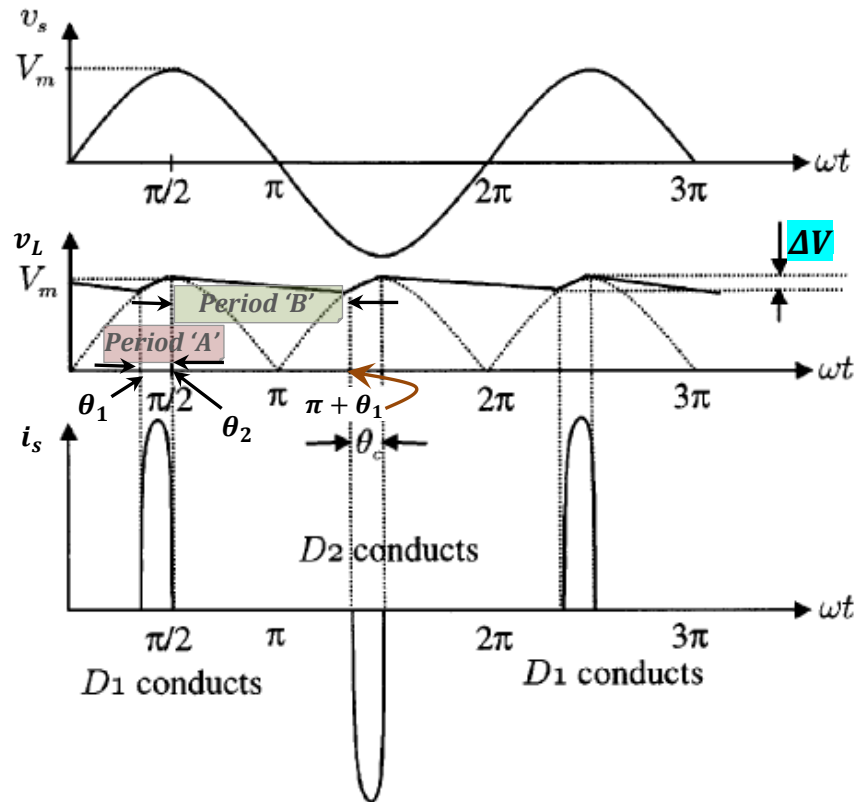

◆ **In period 'A':**

The load voltage is the same as the capacitor voltage, which is the input voltage:

$$v_L = V_m \sin \omega t$$

The capacitor charging current is:

$$i_c = C \frac{dv_L}{dt} = C\omega V_m \cos \omega t$$

The load current is:

$$i_L = \frac{V_m \sin \omega t}{R}$$

The diode current,  $i$ , is:

$$i = i_c + i_L = V_m \left( C\omega \cos \omega t + \frac{\sin \omega t}{R} \right)$$

This current has very high values as shown in the previous Figure.

**To find  $\theta_2$ :**

At  $\theta_2$ , the diode current  $i = 0$ . Taking  $RC \gg \frac{T}{2}$  (or half the supply period),  $\theta_2$  is close to  $\frac{\pi}{2}$  and can be normally taken to be  $\frac{\pi}{2}$ .

However, for  $i = 0$  yields,

$$\begin{aligned} \omega t &= \tan^{-1}(-\omega RC) \\ \text{i.e. } \theta_2 &= \tan^{-1}(-\omega RC) \end{aligned}$$

**To find  $\theta_1$ :**

In period B, from  $\omega t = \theta_2$  to  $\omega t = \pi + \theta_1$ , there is no diode conducting, and the load current is supplied by the capacitor; i.e.,

$$C \frac{dv_L}{dt} + \frac{v_L}{R} = 0$$

which has a solution,

$$v_L = V_m e^{-\frac{t'}{RC}}, \text{ using a false time origin where } t' = 0 \text{ at } \omega t = \frac{\pi}{2}, \text{ or strictly at } \omega t = \theta_2$$

The decaying exponential  $\left( V_m e^{-\frac{t'}{RC}} \right)$  meets the rising sine wave  $(-V_m \sin \omega t, \text{ or } -V_m \cos \omega t')$  due to axis shift). Thus,  $\theta_1$  can be found by trial and error, starting from an angle, which is  $\frac{\pi}{6}$  off (prior) the peak of the cosine function; as illustrated in the Table next.

| $\omega t'$  | $-V_m \cos \omega t'$ | $V_m e^{-\frac{\omega t'}{\omega RC}}$ |
|--|-----------------------|--|
| $\frac{5\pi}{6}$   | check $>?<=?$         | $<?>=?$                                |
| $\frac{5\pi}{6} + \Delta\theta$ or $\frac{5\pi}{6} - \Delta\theta$ ; depending on the values of the two functions! | $>?<=?$               | $<?>=?$                                |
| Continue... until they interchange relative magnitudes within a specified acceptable $\Delta\theta$                | ?                     | ?                                      |

Dr. M. Abu-Khaizaram, BZU, Fall 2017

## A Simplified Analysis for Capacitor Smoothing

An estimate of the ripple is often all that is needed, an overestimate of the ripple,  $\Delta V$ , adequate for most cases, is obtained by assuming that the discharging of the capacitor is linear (remember that the time constant ' $RC$ ' is much greater than the half supply period), and that the discharging occurs over the whole half period; i.e. charging is effectively instantaneous.

The capacitor voltage varies exponentially during discharging. Recalling its time function;

$$v_L = V_m e^{-\frac{t'}{RC}}$$

Using the series expansion,

$$e^{-x} \cong 1 - x; \text{ which is valid for a small } x$$

yields,

$$v_L = V_m \left(1 - \frac{t'}{RC}\right)$$

With  $t' = \frac{T}{2}$  or  $t' = \frac{1}{2f}$ , the value of the capacitor voltage at the end of the discharging period is obtained and has its minimum value;

$$v_{L(\min)} = V_m \left(1 - \frac{1}{2fRC}\right)$$

Then, the peak-to-peak voltage ripple,  $\Delta V$ , is:

$$\begin{aligned} \Delta V &= v_{L(\max)} - v_{L(\min)} \\ \Rightarrow \Delta V &= V_m - V_m \left(1 - \frac{1}{2fRC}\right) \end{aligned}$$

Therefore, for a Single-Phase Full-Wave Rectifier,

$$\Delta V = \frac{V_m}{2fRC}$$

In general, the peak-to-peak voltage ripple at the output of any type of rectifiers depends on the frequency of the ripple ( $f_r$ ) and the maximum value of the output voltage ( $V_{max}$ ), as:

$$\Delta V = \frac{V_{max}}{f_r RC}$$

The average output voltage is:

$$V_{dc} = V_{max} - \frac{\Delta V}{2}$$

$$\Rightarrow V_{dc} = V_{max} - \frac{V_{max}}{2f_r RC}$$

$$\Rightarrow V_{dc} = V_{max} \left( \frac{2f_r RC - 1}{2f_r RC} \right)$$

If the peak-to-peak voltage ripple is small, then the average load current,  $I$ , can be approximated as:

$$I = \frac{V_{max}}{R}$$

Thus,

$$\Delta V = \frac{I}{f_r C}$$

Note that, increasing the load current increases the peak-to-peak voltage ripple and, therefore, reduces the average output voltage.

The rms value of the ripple (AC component), assuming a sinusoidal waveform, is approximated as:

$$V_{ac} = \frac{\Delta V}{2\sqrt{2}}$$

If a triangular waveform was assumed, then:

$$V_{ac} = \frac{\Delta V}{2\sqrt{3}}$$



However, a sinusoidal waveform provides a more margin for safety, therefore it will be used.

$$V_{ac} = \frac{V_{max}}{2\sqrt{2}(f_r RC)}$$

The Ripple Factor, therefore, is:

$$RF = \frac{V_{ac}}{V_{dc}}$$

$$RF = \frac{\frac{V_{max}}{2\sqrt{2}(f_r RC)}}{V_{max} \left( \frac{2f_r RC - 1}{2f_r RC} \right)}$$

$$RF = \frac{1}{\sqrt{2}(2f_r RC - 1)}$$

### Notes:

- For a determined  $RF$  at the output of a specific rectifier and a particular load, the value of  $C$  can be found!
- If the load resistance is unknown, the load current may be used to calculate  $\Delta V$ ; i.e.,

$$RF = \frac{\frac{I}{2\sqrt{2}(f_r C)}}{V_{max} - \frac{I}{2(f_r C)}}$$

- The following table summarizes values of  $f_r$  and  $V_{max}$  for various types of rectifiers.

| Type of Rectifier                | $f_r$                            | $V_{max}$     |
|----------------------------------|----------------------------------|---------------|
| Single-Phase Half-Wave Rectifier | $f \left( = \frac{1}{T} \right)$ | $V_m$         |
| Single-Phase Full-wave Rectifier | $2f$                             | $V_m$         |
| q-Phase Star Rectifier           | $qf$                             | $V_m$         |
| Three-Phase Half-Wave Rectifier  | $3f$                             | $V_m$         |
| Three-Phase Full-Wave Rectifier  | $6f$                             | $\sqrt{3}V_m$ |

Dr. M. Abu-Khaizaram, BZU, Fall 2017

## Diode Current in a Capacitor Smoothing Rectifier

- For a Full-Wave Bridge Rectifier, the capacitor charges through two diodes in Period 'A'. The larger the capacitor is made to reduce the voltage ripple, the shorter the conduction period and the higher the diode current are.
- Recall, the capacitor voltage ( $v_L$ ) and transformer's secondary current ( $i_s$ ) of a Single-Phase Full-Wave Rectifier, which are shown again in the Figure,

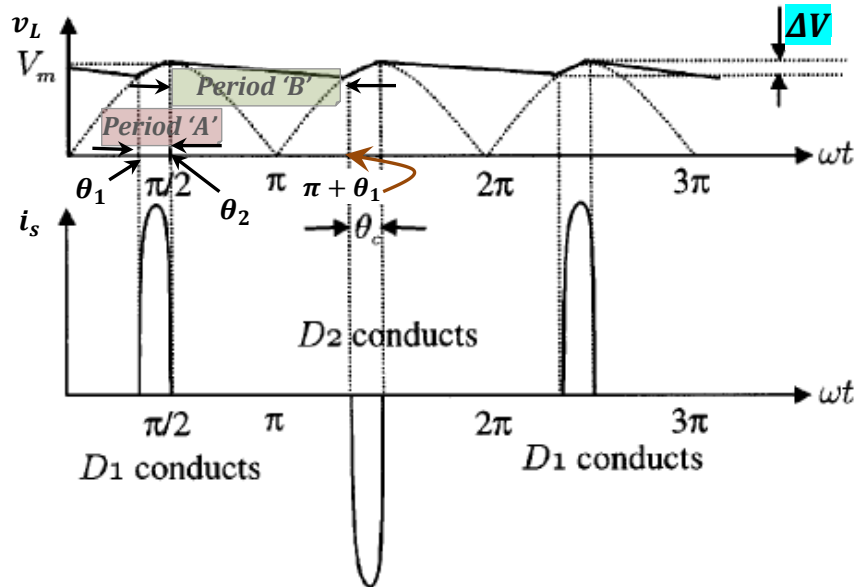

- In practice, the current in Period 'A' is several times the load current, so the diode current,  $i$ , is approximately:

$$i \cong C \frac{dv_L}{dt} = C\omega V_m \cos \omega t$$

- The shape of the load current pulses is modified by the source impedance, particularly if the circuit is supplied through a transformer, which contributes a leakage reactance.
- The pulse nature of the current, not only imposes stress on the diodes and on the smoothing capacitor, but also leads to a **poor power factor** for the circuit. Also, has **high harmonics** in the supply. The source impedance can be augmented, often by adding an inductance, to spread the pulses and reduce harmonic distortion, although this **results in a lower DC voltage**, as will be explained later.
- The widespread use of rectifiers with a capacitor smoothing is the cause of poor wave-shape of the mains (grid); flat-topped sinusoidal.



## 2. Inductor Smoothing

- Assuming the Single-Phase Full-Wave Rectifier shown in the Figure next,
- The inductor stores magnetic energy and uses it to maintain the current by providing the voltage difference between  $v_L$  and  $v_o$ .
- If the inductor is large enough, i.e. the time constant  $\frac{L_f}{R} \gg \frac{1}{2f}$ , the current is continuous and the average voltage is:  $V_{dc} = \frac{2V_m}{\pi}$
- From  $\theta_1$  to  $\theta_2$ ,  $v_L > v_o$ , so the current grows up.
- From  $\theta_2$  to  $\pi + \theta_1$ ,  $v_L < v_o$ , so the current decays.

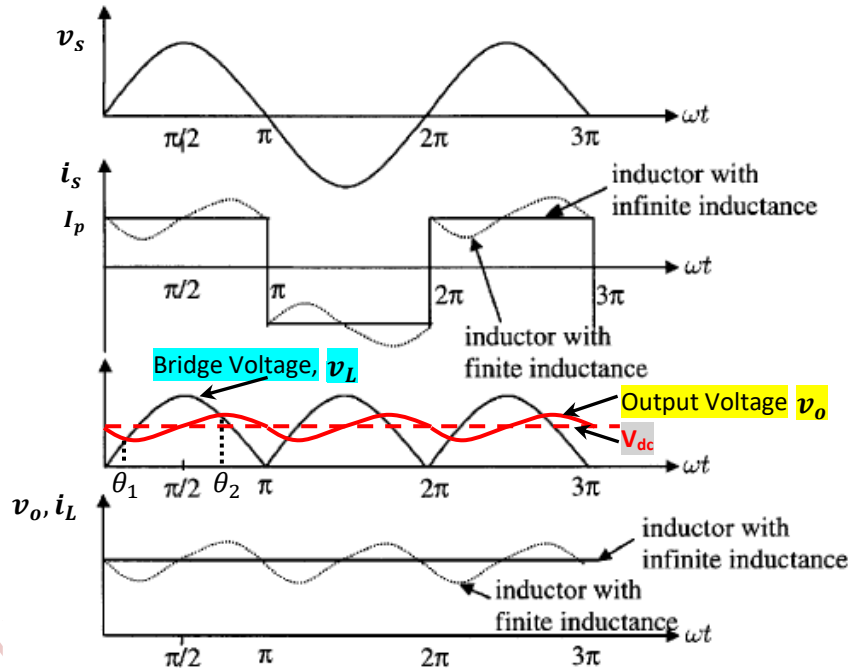
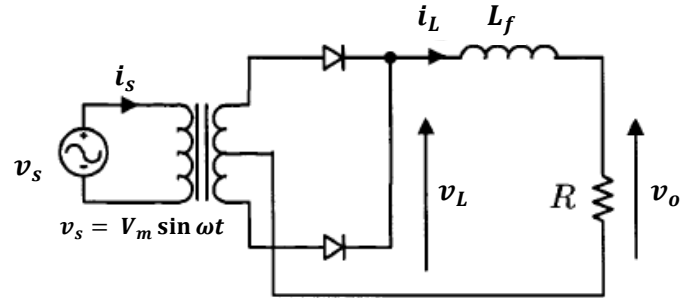

### Calculation of The Ripple by Fourier Analysis:

- The Fourier Analysis of the input voltage to the filter,  $v_L$ , yields a series of sine waves as follows:

$$v_L(t) = \frac{2V_m}{\pi} - \frac{4V_m}{3\pi} \cos 2\omega t - \frac{4V_m}{15\pi} \cos 4\omega t - \frac{4V_m}{35\pi} \cos 6\omega t - \dots$$

- By applying superposition, the equivalent circuit for  $2\omega$  component, is:

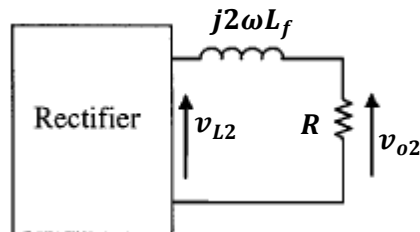

- ◆ The ripple voltage across the load due to  $2\omega$  component,  $v_{o2}$ , is found by potential division, as:

$$v_{o2} = \frac{4V_m}{3\pi} \left( \frac{R}{\sqrt{R^2 + (2\omega L_f)^2}} \right) \cos(2\omega t - \theta_2)$$

where  $\theta_2 = \tan^{-1} \left( \frac{2\omega L_f}{R} \right)$ , and, similarly,  $\theta_n = \tan^{-1} \left( \frac{n\omega L_f}{R} \right)$

- ◆ The current ripple due to the fundamental component of harmonics ( $2\omega$  component) is:

$$i_2 = \frac{v_{o2}}{R}$$

$$i_2 = \frac{4V_m}{3\pi} \left( \frac{1}{\sqrt{R^2 + (2\omega L_f)^2}} \right) \cos(2\omega t - \theta_2)$$

- ◆ If  $2\omega L_f \gg R$ , then the amplitude of the voltage ripple due to the fundamental component of harmonics is:

$$\hat{v}_{o2} = \frac{4V_m}{3\pi} \left( \frac{R}{2\omega L_f} \right)$$

- ◆ Then, the amplitude of the current ripple due to the fundamental component of harmonics is:

$$\hat{i}_2 = \frac{4V_m}{3\pi} \left( \frac{1}{2\omega L_f} \right)$$

- ◆ The amplitude of higher harmonics can be ignored as not only are their initial magnitudes small, but they are also more attenuated.

- ◆ The Ripple Factor (RF) is:

$$RF = \frac{I_{ac}}{I_{dc}} \cong \frac{\hat{i}_2/\sqrt{2}}{I_{dc}}$$

where  $I_{ac}$  is the rms value of the AC component of the current ripple.

- ◆ For a specified  $RF$  and average DC value, the value of  $L_f$  can be found!

- ◆ Note that, if the time constant  $\frac{L_f}{R} \gg \frac{1}{2f}$ , the supply current is continuous and is close to sinusoidal, so the harmonic content is low. If the load resistance increases, the time constant  $\frac{L_f}{R}$  reduces and the smoothing will become ineffective. The regulation of the circuit is made worse by the DC resistance of the inductor.

### 3. Combination of Inductors and Capacitors

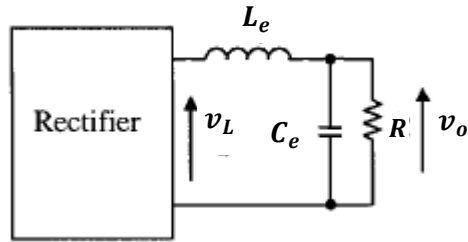

- Applying superposition, for the  $n^{\text{th}}$  harmonic component (the dominant harmonic), the equivalent circuit of the rectifier and the LC filter becomes as:

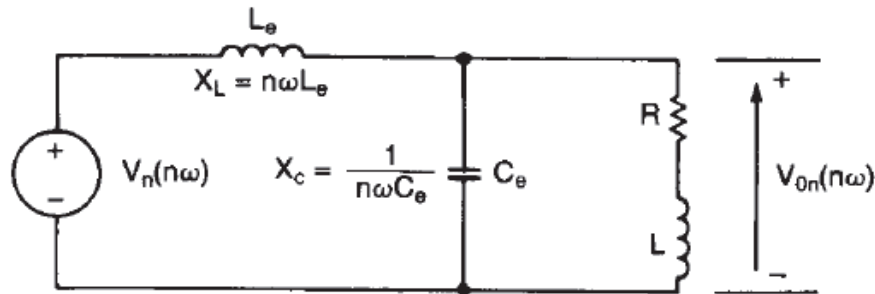

- For the  $n^{\text{th}}$  harmonic current to pass through the capacitor filter, the following condition must be satisfied:

$$\sqrt{R^2 + (n\omega L)^2} \gg \frac{1}{n\omega C_e}$$

- This condition is satisfied by the relation:

$$\sqrt{R^2 + (n\omega L)^2} = \frac{10}{n\omega C_e}$$

- If so, then the load can be neglected, and the value of  $C_e$  can be calculated as:

$$C_e = \frac{10}{n\omega \sqrt{R^2 + (n\omega L)^2}}$$

- The rms value of the  $n^{\text{th}}$  harmonic voltage at the output is:

$$V_{on}(n\omega) = \frac{\frac{1}{n\omega C_e}}{n\omega L_e - \frac{1}{n\omega C_e}} V_n(n\omega)$$

$$\Rightarrow V_{on}(n\omega) = \frac{1}{(n\omega)^2 L_e C_e - 1} V_n(n\omega)$$

- The total amount of ripple voltage due to harmonics (for a Single-Phase Full-Wave Bridge) is:

$$V_{ac} = \sqrt{\sum_{n=2,4,6\dots}^{\infty} (V_{on}(n\omega))^2}$$

- Considering the dominant harmonic, in this case the second harmonic voltage ( $V_2(2\omega)$ );

$$\hat{V}_2(2\omega) = \frac{4V_m}{3\pi}$$

- Therefore,

$$V_{ac} \cong V_{o2}(2\omega) = \frac{1}{(2\omega)^2 L_e C_e - 1} \frac{\hat{V}_2(2\omega)}{\sqrt{2}}$$

where  $V_{o2}(2\omega)$  is the rms value of the output voltage due to the fundamental harmonic (the second harmonic in a Single Phase Full Bridge).

- Since  $C_e$  was calculated before,  $L_e$  can be calculated from the desired (maximum allowed) Ripple Factor;

$$RF = \frac{V_{ac}}{V_{dc}} \cong \frac{V_{o2}(2\omega)}{V_{dc}}$$

$$\Rightarrow RF = \frac{1}{(2\omega)^2 L_e C_e - 1} \frac{\hat{V}_2(2\omega)/\sqrt{2}}{V_{dc}}, \text{ find } L_e!$$

### Example 2-15

A  $LC$  filter as shown in Fig. 2-20c is used to reduce the ripple content of the output voltage for a single-phase full-wave rectifier. The load resistance,  $R = 40 \Omega$ , load inductance,  $L = 10 \text{ mH}$ , and source frequency is  $60 \text{ Hz}$  (or  $377 \text{ rad/s}$ ). Determine the values of  $L_e$  and  $C_e$  so that the ripple factor of the output voltage is  $10\%$ .

**Solution** The equivalent circuit for the harmonics is shown in Fig. 2-24. To make it easier for the  $n$ th harmonic ripple current to pass through the filter capacitor, the load impedance must be greater than that of the capacitor:

$$\sqrt{R^2 + (n\omega L)^2} \gg \frac{1}{n\omega C_e}$$

This condition is generally satisfied by the relation

$$\sqrt{R^2 + (n\omega L)^2} = \frac{10}{n\omega C_e} \quad (2-90)$$

and under this condition, the effect of the load will be negligible. The rms value of the  $n$ th harmonic component appearing on the output can be found by using the voltage-divider rule and is expressed as

$$V_{on} = \frac{1/(n\omega C_e)}{(n\omega L_e) - 1/(n\omega C_e)} V_n = \frac{1}{(n\omega)^2 L_e C_e - 1} V_n \quad (2-91)$$

The total amount of ripple voltage due to all harmonics is

$$V_{ac} = \left( \sum_{n=2,4,6,\dots}^{\infty} V_{on}^2 \right)^{1/2} \quad (2-92)$$

For a specified value of  $V_{ac}$  and with the value of  $C_e$  from Eq. (2-90), the value of  $L_e$  can be computed. We can simplify the computation by considering only the dominant harmonic. From Eq. (2-63) we find that the second harmonic is the dominant one and its rms value is  $V_2 = 4V_m/(3\sqrt{2}\pi)$  and the dc value,  $V_{dc} = 2V_m/\pi$ .

For  $n = 2$  Eqs. (2-91) and (2-92) give

$$V_{ac} = V_{o2} = \frac{1}{(2\omega)^2 L_e C_e - 1} V_2$$

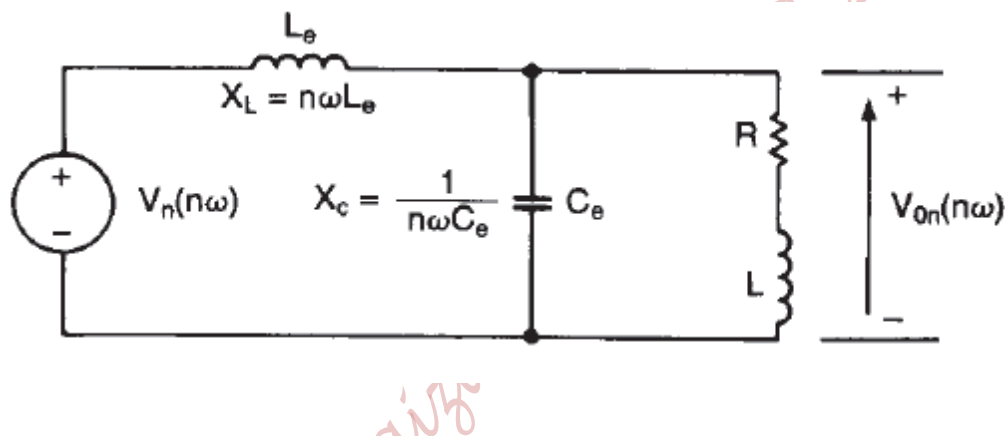

The value of the filter capacitor is calculated as

$$\sqrt{R^2 + (2\omega L)^2} = \frac{10}{2\omega C_e}$$

or

$$C_e = \frac{10}{4\pi f \sqrt{R^2 + (4\pi f L)^2}} = 326 \mu\text{F}$$

From Eq. (2-47) the ripple factor is defined as

$$\text{RF} = \frac{V_{ac}}{V_{dc}} = \frac{V_{o2}}{V_{dc}} = \frac{V_2}{V_{dc}} \frac{1}{(4\pi f)^2 L_e C_e - 1} = \frac{\sqrt{2}}{3} \frac{1}{[(4\pi f)^2 L_e C_e - 1]} = 0.1$$

or  $(4\pi f)^2 L_e C_e - 1 = 4.714$  and  $L_e = 30.83 \text{ mH}$ .

## The Effect of Source and Load Inductances

- Consider a Three-Phase Full-Wave Rectifier supplying a highly inductive load (e.g., a DC motor) as shown in the Figure below,

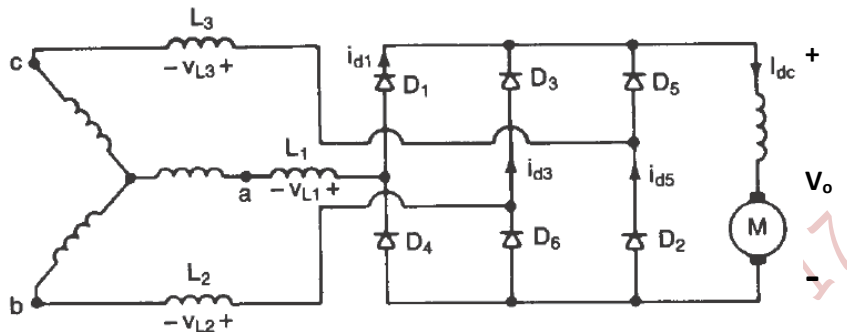

- The large load inductance causes the load current to become continuous and ripple free (constant).
- Current commutation occurs every  $120^\circ$  between two diodes at the same level of the rectifier; top or bottom.
- The source inductances prevent instantaneous change in the diodes' currents during commutation.
- Considering the Figure below, the current commutation between  $D_1$  and  $D_3$ , the commutation starts at an angle  $\omega t = \pi$ , and lasts for an angle,  $\alpha$ , called **the Commutation or Overlap Period (angle)**, as illustrated in the corresponding voltage and current waveforms of the Figure.

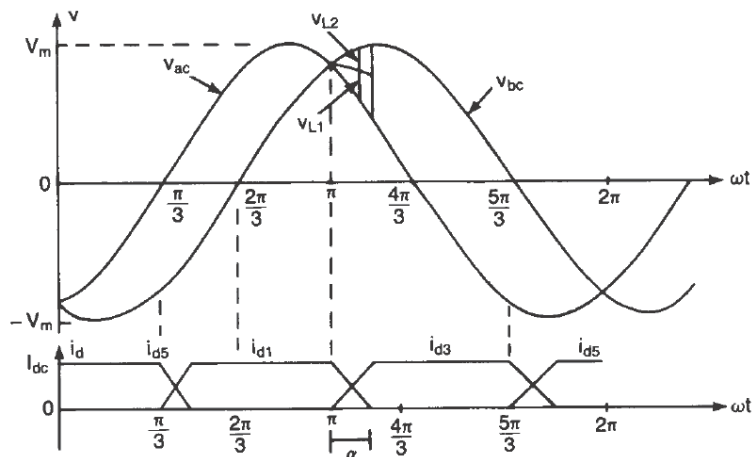

- As  $i_{d1}$  decreases, a voltage  $+V_{L1}$  will be induced across the source inductance  $L_1$ , with the polarity marked on the circuit of the Figure above.
- The output voltage is, therefore,  $V_o = V_{ac} + V_{L1}$  ;
- Noting that  $D_2$  stays conductive during the aforementioned commutation period.

- As  $i_{d3}$  increases, a voltage  $-V_{L2}$  will be induced across the source inductance  $L_2$ , with a polarity opposite to that is marked on the circuit of the previous Figure.
- The output voltage, therefore, is  $V_o = V_{bc} - V_{L2}$ .
- The result is that, the **Anode voltages of  $D_1$  and  $D_3$  are equal**; both diodes conduct for a certain period named **Commutation or Overlap Period**.
- The difference between the voltages  $V_{bc}$  and  $V_{ac}$  is divided across the inductances  $L_1$  and  $L_2$ .
- Note that, there is no change in the current of the Diode  $D_2$ ,  $i_{d2} = I_{dc}$ , and hence  $V_{L3} = 0$ .
- The effect of Overlap Period (angle) is reducing the average output voltage of the rectifier.
- The voltage across the inductance  $L_2$  is:

$$V_{L2} = L_2 \frac{di}{dt}$$

- Assuming a linear current rise (or fall),

$$V_{L2} = L_2 \frac{\Delta i}{\Delta t}$$

$$\Rightarrow V_{L2} \Delta t = L_2 \Delta i$$

- The commutation process is repeated **6** times for a Three-Phase Full-Wave Bridge.

- Thus, the average voltage reduction  $V_x$  due to commutation is:

$$V_x = \frac{1}{T} 2(V_{L1} + V_{L2} + V_{L3}) \Delta t$$

$$\therefore V_x = 2f(L_1 + L_2 + L_3) \Delta i$$

where  $f = \frac{1}{T}$  is the source frequency, and  $\Delta i = I_{dc}$ ;

$$\Rightarrow V_x = 2f(L_1 + L_2 + L_3) I_{dc}$$

If all inductances are equal to a commutation inductance;  $L_c = L_1 = L_2 = L_3$ , then the **average voltage reduction in a Three-Phase Full-Wave Bridge Rectifier** becomes:

$$\mathbf{V_x = 6fL_c I_{dc}}$$

- Note that, the average voltage reduction in a **Single-Phase Full-Wave Bridge Rectifier** can be derived as:

$$V_x = 2fL_c \Delta i$$

But, here  $\Delta i = 2I_{dc}$ , as the current reverses its direction in the source inductance!

$$V_x = 2fL_c 2(I_{dc}),$$

$$\mathbf{V_x = 4fL_c I_{dc}}$$

- However, the average voltage reduction in a Half-Wave Bridge Rectifier is  **$V_x = fL_c I_{dc}$** .

- The **actual output DC voltage**, therefore, is:  **$V_{avg} = V_{dc} - V_x$**

**Example 2-17**

A three-phase bridge rectifier is supplied from a Y-connected 208-V 60-Hz supply. ~~The average output voltage is 170 V.~~ The load current is 60 A and has negligible ripple. Calculate the percentage reduction of output voltage due to commutation if the line inductance per phase is 0.5 mH.

**Solution**  $L_c = 0.5$  mH,  $V_s = 208/\sqrt{3} = 120$  V,  $f = 60$  Hz,  $I_{dc} = 60$  A, and  $V_m = \sqrt{2} \times 120 = 169.7$  V. From Eq. (2-77),  $V_{dc} = 1.6542 \times 169.7 = 280.7$  V. Equation (2-99) gives the output voltage reduction,

$$V_x = 6 \times 60 \times 0.0005 \times 60 = 10.8 \text{ V or } 10.8 \times \frac{100}{280.7} = 3.85\%$$

and the effective output voltage is  $(280.7 - 10.8) = 266.9$  V.

Dr. M. Abu-Khairzaram, BZU,



## Linear Regulated Power Supplies

- ◆ There are **practical limits**, in terms of **size and cost**, to the reduction in the ripple that can be obtained with capacitor and inductor smoothing. Furthermore, the **DC voltage** from these circuits changes **with the load current**, and also with **fluctuations in the supply voltage**.
- ◆ For many electronic circuits, a stability of 0.1% and a ripple of less than 0.1% are the minimum specification. Electronic Regulators are widely used to meet these needs.

### Basic Linear Regulator:

- The simplest form of a Linear Regulator is depicted in the Figure below.

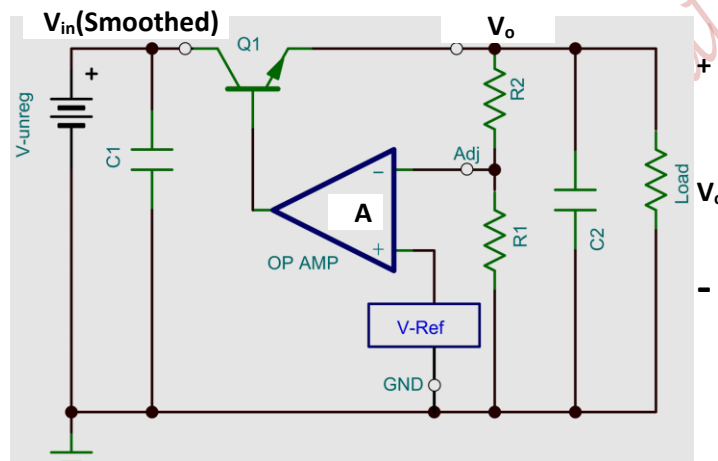

- The regulator circuit is supplied from a smoothed (unregulated) supply and the load current is passed by a Power Transistor ( $Q_1$ ) acting in its **Linear region (Active region)** as an Emitter Follower.
- Assuming that the Differential Amplifier (A) is ideal, it adjusts the base drive of  $Q_1$  to maintain the output voltage at:

$$V_o = \left(1 + \frac{R_2}{R_1}\right) V_{ref}$$

where  $V_{ref}$  is a stable voltage reference; e.g. **a Zener Diode**.

- The output voltage can be set by an appropriate choice of  $R_1$  and  $R_2$ , provided that there is always enough voltage across the Power Transistor ( $Q_1$ ) for correct operation ( **$V_{in}$  is greater than  $V_o$  by at least 1.5V**).
- The whole circuit is usually fabricated as a monolithic Integrated Circuit. Fixed voltage regulators are available for popular voltages such as +15V, -15V, 8V, etc...;

|                              |       |       |       |       |       |       |
|------------------------------|-------|-------|-------|-------|-------|-------|
| <b>Regulator Part Number</b> | 79L05 | 79L08 | 78L05 | 78L08 | 78L15 | 78L18 |
| <b>Output voltage</b>        | -5V   | -8V   | +5V   | +8V   | +15V  | +18V  |

- Photos of regulators are shown below, with their pins connection marked.

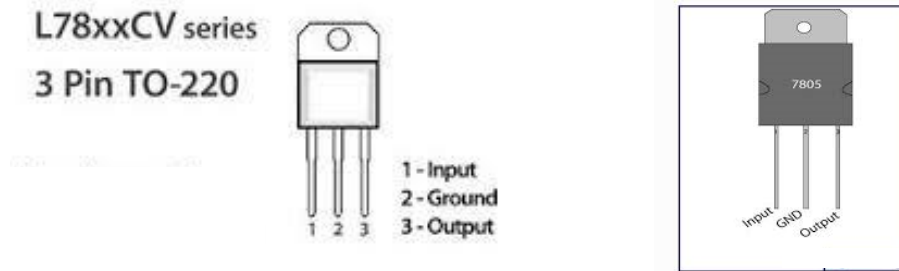

- Above a few Amperes or above 50V, designers usually resort to discrete pass transistors.
- Variable voltage regulators are also made using external resistors to set the output voltage; e.g. LM317M (1A and 1.3V to 37V).

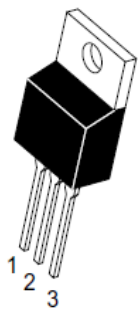

| PIN ASSIGNMENT |        |
|----------------|--------|
| 1              | Adjust |
| 2              | Vout   |
| 3              | Vin    |

- Reference to datasheet must be made for technical specification and prior selection of components.

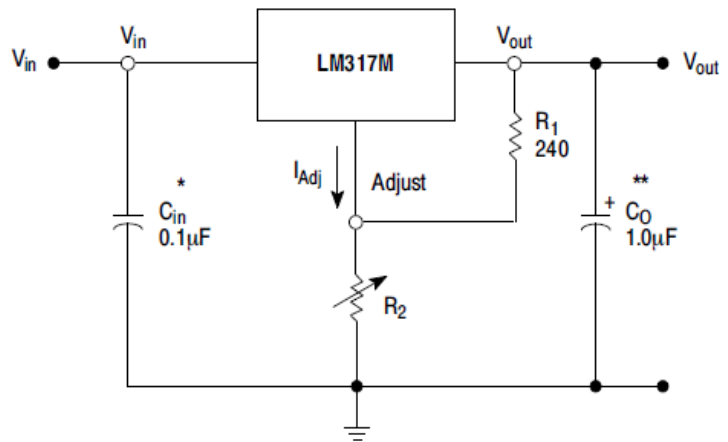

- The output voltage of LM317M is given by (from datasheet):

$$V_{out} = 1.25 \text{ V} \left( 1 + \frac{R_2}{R_1} \right) + I_{Adj} R_2$$

### Practical Example:

An output of 5V at 1A is required. The regulator type is LM317M and is supplied through a Single-Phase Full-Wave Bridge Rectifier fed from 10V<sub>rms</sub> & 50Hz transformer secondary. The voltage drop across the regulator must be at least 1.8V. Assuming the diode's voltage drop is 1V,

- What size of a smoothing capacitor is needed?
- Find the power dissipated in the pass transistor of the regulator?
- If the Ripple Rejection Ratio (RRR) of the regulator is 65dB, then what is the ripple at the output voltage?

#### Solution:

- To find C!

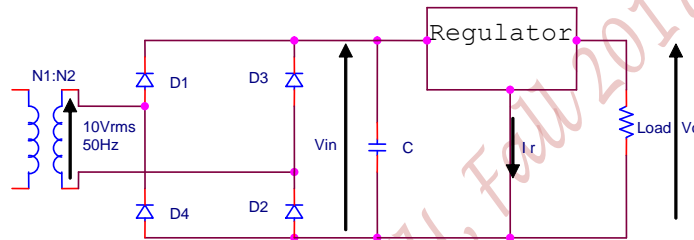

The peak source (transformer's secondary) voltage is:

$$V_m = \sqrt{2}(10) = 14.14V$$

Allowing a 2V voltage drop across the two conducting diodes, then the maximum voltage at the output of the rectifier is:

$$V_{max} = 14.14 - 2 = 12.14V$$

Noting that, the minimum input voltage to the regulator must be 1.8V greater than its output; therefore,

$$V_{min} = 5 + 1.8 = 6.8V$$

The allowed peak-to-peak ripple at the smoothing capacitor (at the output of the rectifier and the input of the regulator) is:

$$\Delta V = V_{max} - V_{min}$$

$$\Delta V = 12.14 - 6.8 = 5.34V$$

But, the peak-to-peak voltage ripple, related to load current and circuit parameters, is:

$$\Delta V = \frac{I}{f_r C}$$

$$\Delta V = \frac{I}{2fC}$$

$$5.34 = \frac{1}{2(50)C} \Rightarrow C = 1,873\mu F$$

Choose  $C = 2,200\mu F$ , as it is the **nearest (higher) preferred value!**

b) To find the power dissipated in the transistor of the regulator ( $Q_1$ ),

The average input voltage to the regulator is:

$$V_{in} = V_{max} - \frac{\Delta V}{2} = 12.14 - \frac{5.6}{2} = 9.34V \quad (\text{based on the ripple with } C = 1,873\mu F)$$

The power dissipated in the transistor of the regulator is the difference between the mean input and output voltages multiplied by the average load current;

$$P_{Q1} = (V_{in} - V_o)I = (9.34 - 5)1 = 4.34W$$

which is within the ratings of the regulator (from the datasheet!)

Note that, the regulator also has built-in short circuit, current overload, and thermal protection.

c) To find the Output voltage Ripple!

The gain in dB is expressed, for power, as:

$$dB = 10 \log \left( \frac{P_o}{P_{in}} \right)$$

The attenuation in dB is expressed, for power, as:

$$dB = 10 \log \left( \frac{P_{in}}{P_o} \right)$$

In terms of voltage, the attenuation in dB is expressed as:

$$dB = 10 \log \left( \frac{V_{in}^2}{V_o^2} \right)$$

$$\Rightarrow dB = 20 \log \left( \frac{V_{in}}{V_o} \right)$$

For the ripple voltage,

$$dB = 20 \log \left( \frac{\Delta V_{in}}{\Delta V_o} \right)$$

$$65 = 20 \log \left( \frac{5.34}{\Delta V_o} \right)$$

$$\frac{65}{20} = \log \left( \frac{5.34}{\Delta V_o} \right) \Rightarrow 10^{\left(\frac{65}{20}\right)} = \frac{5.34}{\Delta V_o} \Rightarrow \Delta V_o = \frac{5.34}{10^{\left(\frac{65}{20}\right)}} \Rightarrow \Delta V_o = \frac{5.34}{1778.28} \Rightarrow \Delta V_o = 3mV!$$

---

# Part III: AC-to-DC Converters: Controlled Rectifiers

---

**Controlled Rectifiers** are power electronic circuits designed to convert an AC voltage (or current) into a **controllable DC** voltage (or current). The output of these controlled rectifiers consists of an average voltage or current (a DC component), plus other (undesirable) AC components called **harmonics**.

## Half-Wave Controlled Rectifiers

Consider the simplest form of a Half-Wave Controlled Rectifier, fed from a transformer secondary and supplying a resistive load, and shown in the Figure below,

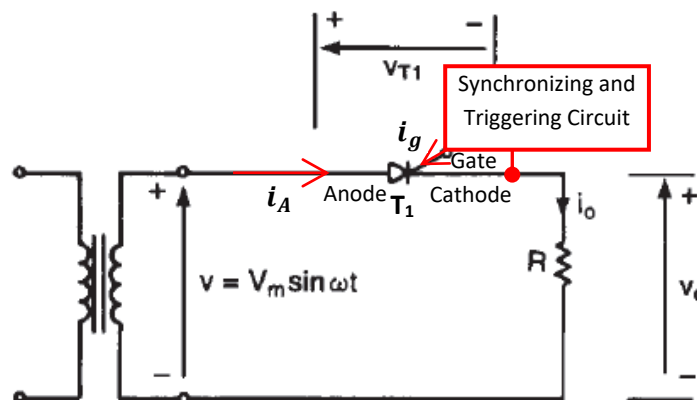

- ◆ The Thyristor ( $T_1$ ) is triggered by applying a pulse of positive gate current with a sufficient duration (long enough to allow the SCR Anode current to rise **above the Latching current ( $I_L$ )**), provided that it is forward biased ( $V_{T1} > V_{on}$ ).  
where,  $V_{on}$  is the on-state voltage drop across the SCR, and it is in the range of [1.5V to 4.5V] depending on voltage and current ratings of the device.
- ◆ The Synchronizing and Triggering Circuit synchronizes the Thyristor's gate signal with the supply voltage and applies an appropriate pulse of Gate current and Gate-Cathode voltage for a proper turning-on of the SCR.

- Assuming an ideal Thyristor,  $T_1$ , and a gate signal is applied at an angle,  $\alpha$  (called Firing, Triggering or Delay angle), the voltage and current waveforms are shown in the Figure below.

- The average output voltage is:

$$V_{dc} = \frac{1}{2\pi} \int_{\alpha}^{\pi} V_m \sin \omega t \, d\omega t$$

$$V_{dc} = \frac{V_m}{2\pi} (-\cos \omega t) \Big|_{\alpha}^{\pi}$$

$$V_{dc} = \frac{V_m}{2\pi} (1 + \cos \alpha)$$

where,  $0 < \alpha < \pi$

- $V_{dc}$  can be varied from  $\frac{V_m}{\pi}$  to 0V by varying  $\alpha$  from 0 to  $\pi$ .
- The output voltage and current have one polarity, hence this converter has one quadrant of operation, as shown in the Figure below.

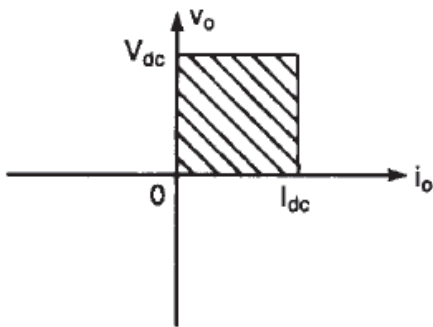

- The root-mean-square of the output voltage is:

$$V_{rms} = \sqrt{\frac{1}{2\pi} \int_{\alpha}^{\pi} (V_m \sin \omega t)^2 \, d\omega t}$$

$$V_{rms} = \sqrt{\frac{(V_m)^2}{4\pi} \int_{\alpha}^{\pi} (1 - \cos 2\omega t) \, d\omega t}$$

$$V_{rms} = \frac{V_m}{2} \sqrt{\frac{1}{\pi} \left( \pi - \alpha + \frac{\sin 2\alpha}{2} \right)}$$

$$0 < \alpha < \pi$$

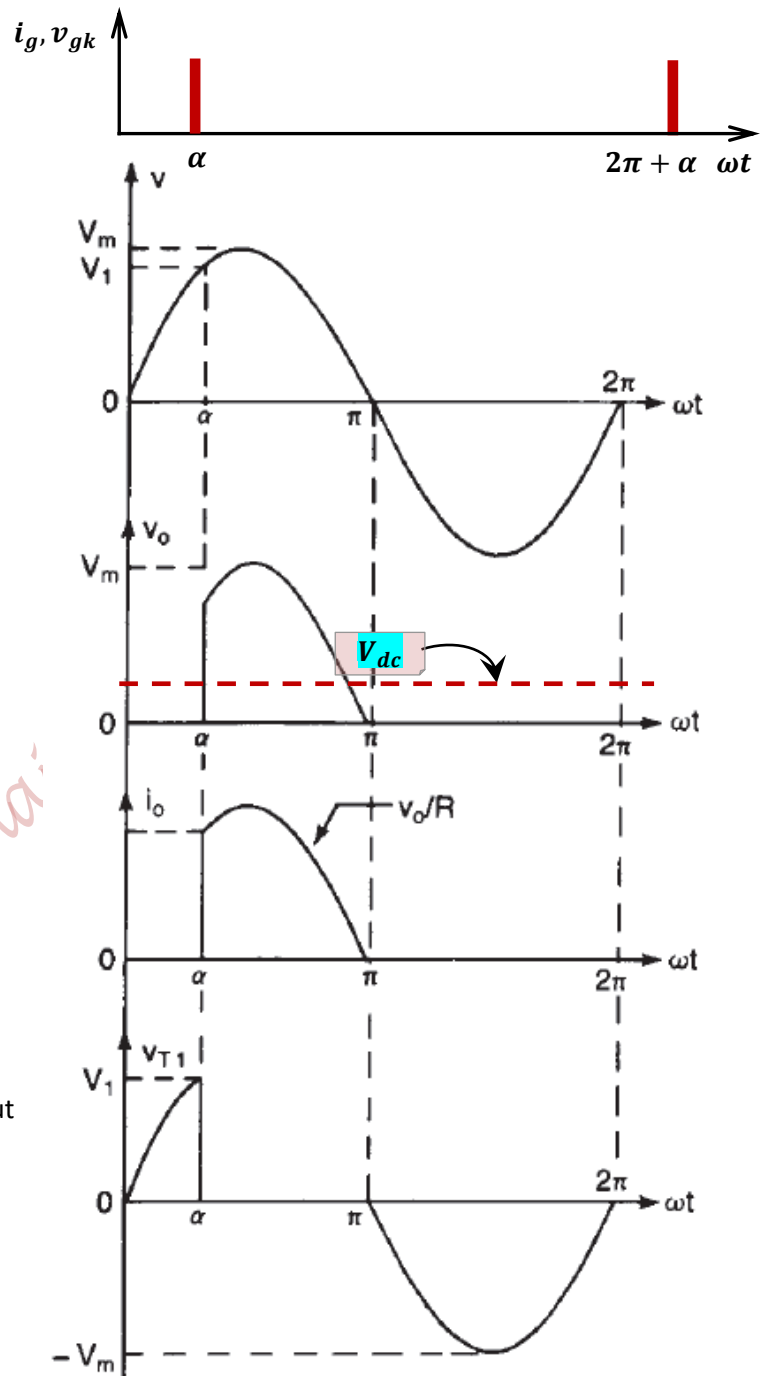

### Example 4-1

If the converter of Figure 4-1a has a purely resistive load of  $R$  and the delay angle is  $\alpha = \pi/2$ , determine the (a) rectification efficiency; (b) form factor, FF; (c) ripple factor, RF; (d) transformer utilization factor, TUF; and (e) peak inverse voltage, PIV, of thyristor  $T_1$ .

**Solution** The delay angle,  $\alpha = \pi/2$ . From Eq. (4-1),  $V_{dc} = 0.1592V_m$  and  $I_{dc} = 0.1592V_m/R$ . From Eq. (4-3),  $V_n = 0.5$  pu. From Eq. (4-4),  $V_{rms} = 0.3536V_m$  and  $I_{rms} = 0.3536V_m/R$ . From Eq. (2-42),  $P_{dc} = V_{dc}I_{dc} = (0.1592V_m)^2/R$  and from Eq. (2-43),  $P_{ac} = V_{rms}I_{rms} = (0.3536V_m)^2/R$ .

(a) From Eq. (2-44) the rectification efficiency,

$$\eta = \frac{(0.1592V_m)^2}{(0.3536V_m)^2} = 20.27\%$$

(b) From Eq. (2-46), the form factor

$$FF = \frac{0.3536V_m}{0.1592V_m} = 2.221 \text{ or } 222.1\%$$

(c) From Eq. (2-48), the ripple factor,  $RF = (2.221^2 - 1)^{1/2} = 1.983$  or 198.3%.

(d) The rms voltage of transformer secondary,  $V_s = V_m/\sqrt{2} = 0.707V_m$ . The rms value of the transformer secondary current is the same as that of the load,  $I_s = 0.3536V_m/R$ . The volt-ampere rating (VA) of the transformer,  $VA = V_sI_s = 0.707V_m \times 0.3536V_m/R$ . From Eq. (2-49),

$$TUF = \frac{0.1592^2}{0.707 \times 0.3536} = 0.1014 \quad \text{and} \quad \frac{1}{TUF} = 9.86$$

(e) The peak inverse voltage,  $PIV = V_m$ .

*Note.* The performance of the converter is degraded at the lower range of delay angle,  $\alpha$ .

Dr. M. . .

## Classification of AC-to-DC Converters

Single-Phase or Three-Phase AC-to-DC Converters can be classified according to number of quadrants of operation as:

- Semi-Converters (one quadrant of operation)
- Full-Converters (two quadrants of operation)
- Dual-Converters (four quadrants of operation)

## Single-Phase Semi-Converters

❖ The circuit topology of a Single-Phase Semi-Converter is shown in the Figure below.

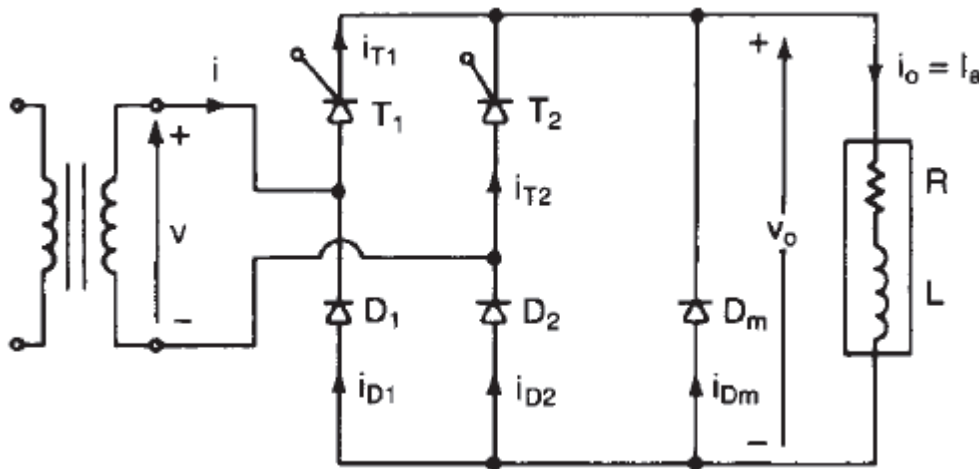

- The load is assumed to be highly inductive with a large time constant, thus the output current ( $i_o$ ) may be considered to be constant, continuous, and ripple-free.
- During the positive half cycle of the input voltage, the Thyristor  $T_1$  and the Diode  $D_2$  are forward biased.
- During the negative half cycle of the input voltage, the Thyristor  $T_2$  and the Diode  $D_1$  are forward biased.
- The Thyristor  $T_1$  is triggered at  $\omega t = \alpha$ .
- For  $\alpha < \omega t < \pi$ , the Thyristor  $T_1$  and the Diode  $D_2$  conduct.
- The voltage and current waveforms are shown in the Figure next.



- During the period  $\pi < \omega t < (\pi + \alpha)$ , the freewheeling diode  $D_m$  is forward biased, and hence it conducts and carries the output current ( $i_o$ ); the output current commutates from  $T_1$  &  $D_2$  to  $D_m$ .
- Consequently,  $T_1$  &  $D_2$  turn off, whilst  $D_m$  turns on at  $\omega t = \pi$ .
- The Thyristor  $T_2$  is triggered at  $\omega t = \pi + \alpha$ .
- Since the Thyristor  $T_2$  and the Diode  $D_1$  are forward biased during the period  $(\pi + \alpha) < \omega t < 2\pi$ , they conduct, applying a reverse voltage across the freewheeling diode,  $D_m$ .
- Consequently, the output current commutates from  $D_m$  to  $T_2$  &  $D_1$ ;  $D_m$  turns off, whilst  $T_2$  &  $D_1$  turn on at  $\omega t = \pi + \alpha$ .
- This process is repeated and so forth...
- Note that, any conducting Thyristor turns off only when its Anode current ( $i_T$ ) falls below the Holding current. Since the load is highly inductive (has a large time constant), it maintains the current at its steady state value even though the output voltage is decreasing to small values, or even becoming negative!

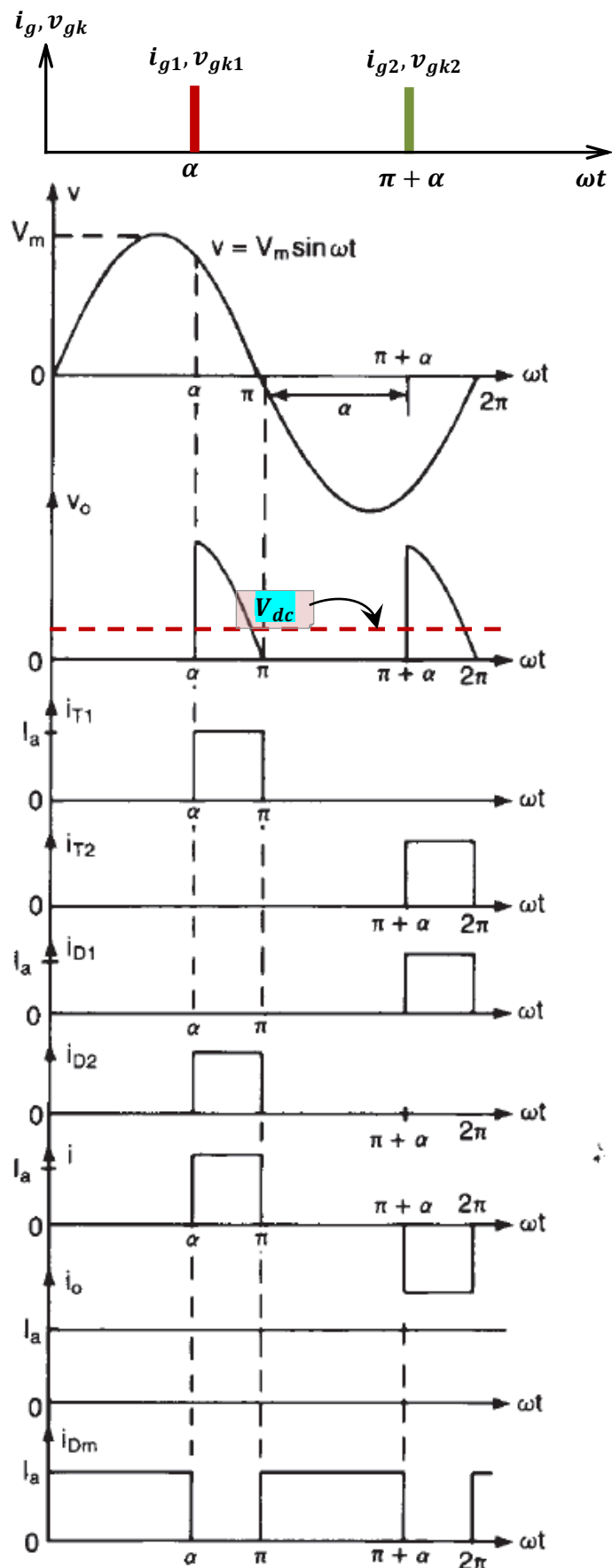

- Note also that, if the freewheeling diode was removed, the output current will circulate within one converter leg, whichever had its Thyristor conductive. The conductive Thyristor turns off when the other forward biased Thyristor turns on.
- If the Semi-Converter had no freewheeling Diode, the conduction power loss would be greater; two devices will be conducting during freewheeling!

- Due to having a freewheeling diode (or due to the presence of diodes in the legs) in this converter, the output voltage cannot be negative (also the output current cannot be negative)! Hence, this converter has **one quadrant of operation only**, as shown in the Figure next.

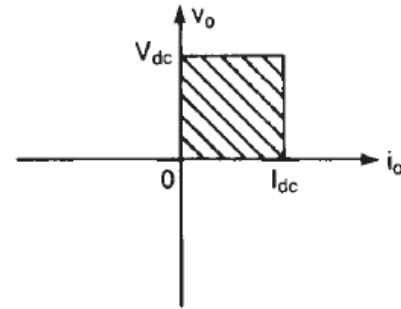

- The average output voltage is:

$$V_{dc} = \frac{2}{2\pi} \int_{\alpha}^{\pi} V_m \sin \omega t d\omega t$$

$$V_{dc} = \frac{2V_m}{2\pi} (-\cos \omega t |_{\alpha}^{\pi})$$

$$V_{dc} = \frac{V_m}{\pi} (1 + \cos \alpha); \quad 0 < \alpha < \pi$$

- $V_{dc}$  can be varied from  $\frac{2V_m}{\pi}$  to 0V by varying  $\alpha$  from 0 to  $\pi$ .

- The **root-mean-square** of the output voltage is:

$$V_{rms} = \sqrt{\frac{2}{2\pi} \int_{\alpha}^{\pi} (V_m \sin \omega t)^2 d\omega t}$$

$$V_{rms} = \sqrt{\frac{(V_m)^2}{2\pi} \int_{\alpha}^{\pi} (1 - \cos 2\omega t) d\omega t}$$

$$V_{rms} = \frac{V_m}{\sqrt{2}} \sqrt{\frac{1}{\pi} \left( \pi - \alpha + \frac{\sin 2\alpha}{2} \right)}; \quad 0 < \alpha < \pi$$

- $V_{rms}$  can be varied from  $\frac{V_m}{\sqrt{2}}$  to 0V by varying  $\alpha$  from 0 to  $\pi$ .

- If the load was resistive, then the freewheeling diode does not conduct. The output current will have the same wave-shape as that of the output voltage; each Thyristor will turn off when its Anode current falls below the Holding current at the end of the corresponding half cycle, i.e. at  $\pi$  or  $2\pi$ .

### Example 4-2

The semiconverter in Fig. 4-2a is connected to a 120-V 60-Hz supply. The load current,  $I_a$ , can be assumed to be continuous and its ripple content is negligible. The turns ratio of the transformer is unity. (a) Express the input current in a Fourier series; determine the harmonic factor of input current, HF; displacement factor, DF; and input power factor, PF. (b) If delay angle is  $\alpha = \pi/2$ , calculate  $V_{dc}$ ,  $V_n$ ,  $V_{rms}$ , HF, DF, and PF.

**Solution** (a) The waveform for input current is shown in Fig. 4-2c and the instantaneous input current can be expressed in a Fourier series as

$$i(t) = I_{dc} + \sum_{n=1,2,\dots}^{\infty} (a_n \cos n\omega t + b_n \sin n\omega t) \quad (4-8)$$

where

$$I_{dc} = \frac{1}{2\pi} \int_{\alpha}^{2\pi} i(t) d(\omega t) = \frac{1}{2\pi} \left[ \int_{\alpha}^{\pi} I_a d(\omega t) - \int_{\pi+\alpha}^{2\pi} I_a d(\omega t) \right] = 0$$

$$\begin{aligned} a_n &= \frac{1}{\pi} \int_{\alpha}^{2\pi} i(t) \cos n\omega t d(\omega t) \\ &= \frac{1}{\pi} \left[ \int_{\alpha}^{\pi} I_a \cos n\omega t d(\omega t) - \int_{\pi+\alpha}^{2\pi} I_a \cos n\omega t d(\omega t) \right] \\ &= -\frac{2I_a}{n\pi} \sin n\alpha \quad \text{for } n = 1, 3, 5, \dots \\ &= 0 \quad \text{for } n = 2, 4, 6, \dots \end{aligned}$$

$$\begin{aligned} b_n &= \frac{1}{\pi} \int_{\alpha}^{2\pi} i(t) \sin n\omega t d(\omega t) \\ &= \frac{1}{\pi} \left[ \int_{\alpha}^{\pi} I_a \sin n\omega t d(\omega t) - \int_{\pi+\alpha}^{2\pi} I_a \sin n\omega t d(\omega t) \right] \\ &= \frac{2I_a}{n\pi} (1 + \cos n\alpha) \quad \text{for } n = 1, 3, 5, \dots \\ &= 0 \quad \text{for } n = 2, 4, 6, \dots \end{aligned}$$

Since  $I_{dc} = 0$ , Eq. (4-8) can be written as

$$i(t) = \sum_{n=1,2,\dots}^{\infty} \sqrt{2} I_n \sin(n\omega t + \phi_n) \quad (4-9)$$

where

$$\phi_n = \tan^{-1} \frac{a_n}{b_n} = -\frac{n\alpha}{2} \quad (4-10)$$

The rms value of the  $n$ th harmonic component of the input current is derived as

$$I_n = \frac{1}{\sqrt{2}} (a_n^2 + b_n^2)^{1/2} = \frac{2\sqrt{2} I_a}{n\pi} \cos \frac{n\alpha}{2} \quad (4-11)$$

From Eq. (4-11), the rms value of the fundamental current is

$$I_1 = \frac{2\sqrt{2} I_a}{\pi} \cos \frac{\alpha}{2} \quad (4-12)$$

The rms input current can be calculated from Eq. (4-11) as

$$I_s = \left( \sum_{n=1,2,\dots}^{\infty} I_n^2 \right)^{1/2}$$

$I_s$  can also be determined directly from

$$I_s = \left[ \frac{2}{2\pi} \int_{\alpha}^{\pi} I_a^2 d(\omega t) \right]^{1/2} = I_a \left( 1 - \frac{\alpha}{\pi} \right)^{1/2} \quad (4-13)$$

From Eq. (2-51), HF =  $[(I_s/I_1)^2 - 1]^{1/2}$  or

$$\text{HF} = \left[ \frac{\pi(\pi - \alpha)}{4(1 + \cos \alpha)} - 1 \right]^{1/2} \quad (4-14)$$

From Eqs. (2-50) and (4-10),

$$\text{DF} = \cos \phi_1 = \cos - \frac{\alpha}{2} \quad (4-15)$$

From Eq. (2-52),

$$\text{PF} = \frac{I_1}{I_s} \cos \frac{\alpha}{2} = \frac{\sqrt{2}(1 + \cos \alpha)}{[\pi(\pi - \alpha)]^{1/2}} \quad (4-16)$$

(b)  $\alpha = \pi/2$  and  $V_m = \sqrt{2} \times 120 = 169.83$  V. From Eq. (4-5),  $V_{dc} = (V_m/\pi)(1 + \cos \alpha) = 51.57$  V, from Eq. (4-6),  $V_n = 0.5$  pu, and from Eq. (4-7),

$$V_{rms} = \frac{V_m}{\sqrt{2}} \left[ \frac{1}{\pi} \left( \pi - \alpha + \frac{\sin 2\alpha}{2} \right) \right]^{1/2} = 81 \text{ V}$$

$$I_1 = \frac{2\sqrt{2} I_a}{\pi} \cos \frac{\pi}{4} = 0.6366 I_a$$

$$I_s = I_a \left( 1 - \frac{\alpha}{\pi} \right)^{1/2} = 0.7071 I_a$$

$$\text{HF} = \left[ \left( \frac{I_s}{I_1} \right)^2 - 1 \right]^{1/2} = 0.4835 \text{ or } 48.35\%$$

$$\phi_1 = -\frac{\pi}{4} \quad \text{and} \quad \text{DF} = \cos -\frac{\pi}{4} = 0.7071$$

$$\text{PF} = \frac{I_1}{I_s} \cos \frac{\alpha}{2} = 0.6366 \text{ (lagging)}$$

*Note.* The performance parameters of the converter depend on the delay angle,  $\alpha$ .

## Single-Phase Full Converters

- The circuit topology of a Single-Phase Full-Converter feeding a Highly Inductive Load is shown in the Figure below.

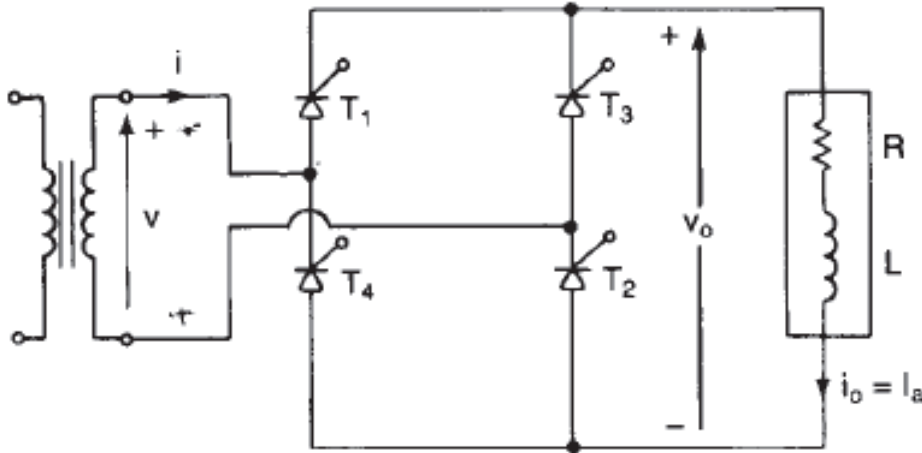

- During the positive half cycle of the input voltage, the Thyristors  $T_1$  &  $T_2$  are forward biased.
- During the negative half cycle of the input voltage, the Thyristors  $T_3$  &  $T_4$  are forward biased.
- $T_1$  and  $T_2$  are triggered simultaneously at  $\omega t = \alpha$ .
- $T_3$  and  $T_4$  are triggered simultaneously at  $\omega t = \pi + \alpha$ .
- During one cycle, because the load is highly inductive, the load current is maintained at its steady state value, which is almost constant, regardless of the value of load voltage; there is enough energy stored in the load inductance's magnetic field!
- Therefore, the load current continues flowing through the already triggered (conductive) Thyristors, despite the reversal of the supply voltage.
- In other words, the Thyristors  $T_1$  &  $T_2$  continue conduction beyond  $\omega t = \pi$ , even though the input voltage is negative, because their Anode currents are higher than the Holding current.

- The corresponding voltage and current waveforms of a Single-Phase Full-Converter are shown in the Figure next.
- $T_1$  and  $T_2$  are triggered simultaneously at  $\omega t = \alpha$ , and because they are forward biased, they will turn on.
- Since the load is highly inductive, the output current, which is greater than the Holding current, continues flowing via  $T_1$  and  $T_2$  beyond  $\omega t = \pi$ , applying the negative supply voltage across the output, as clearly seen in the Figure.
- At  $\omega t = \pi + \alpha$ ,  $T_3$  and  $T_4$  are triggered simultaneously, and because they are forward biased, they will turn on applying a reverse voltage across the conducting Thyristors;  $T_1$  and  $T_2$ . Therefore,  $T_1$  and  $T_2$  will turn off.
- $T_1$  and  $T_2$  are turned off due to Line or Natural Commutation; the load current commutates to  $T_3$  and  $T_4$ .
- In the periods  $[\alpha$  to  $\pi]$  and  $[\pi + \alpha$  to  $2\pi]$ , the converter is in Rectification mode and the power flows from the source to the load.
- In the periods  $[0$  to  $\alpha]$  and  $[\pi$  to  $\pi + \alpha]$ , the converter is in Inversion mode and the power flows from the load to the source.
- Since the output voltage may have both polarities; positive and negative, the converter has two quadrants of operation as illustrated in the Figure next.

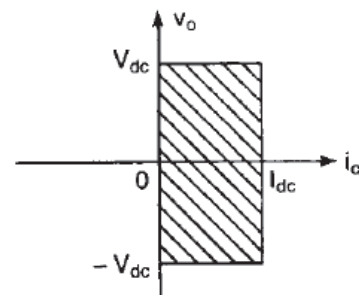
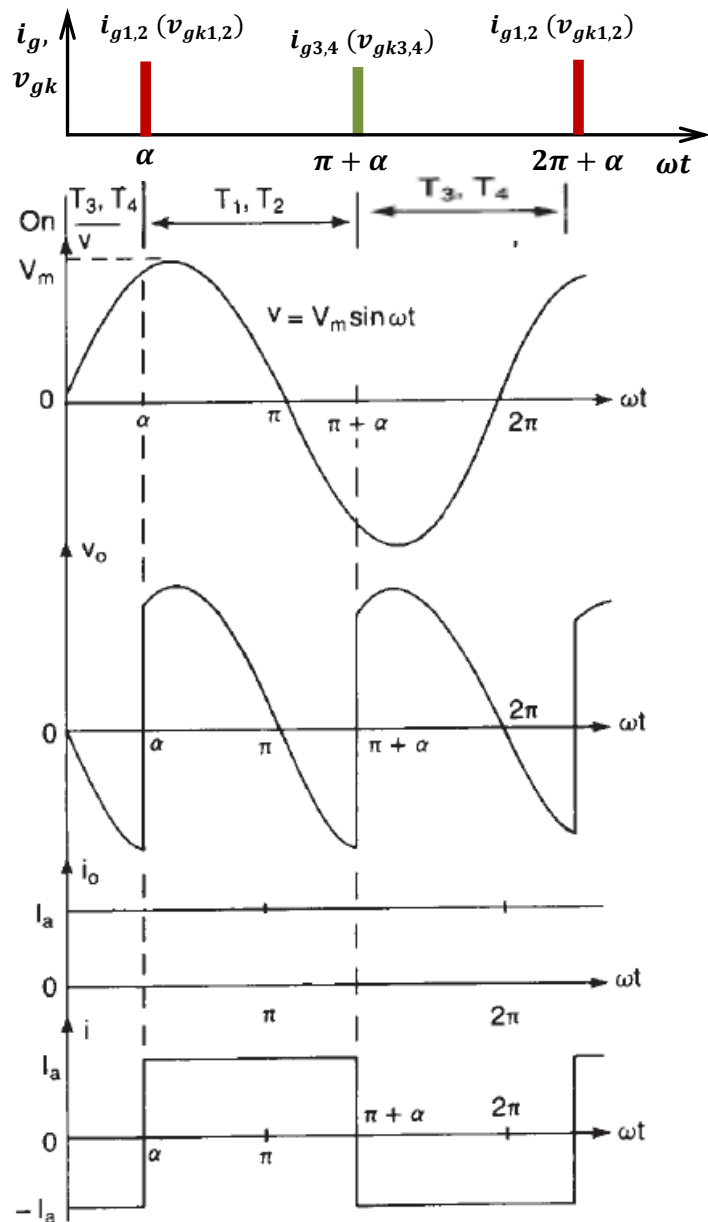

- The average output voltage is:

$$V_{dc} = \frac{2}{2\pi} \int_{\alpha}^{\pi+\alpha} V_m \sin \omega t \, d\omega t$$

$$V_{dc} = \frac{2V_m}{2\pi} (-\cos \omega t |_{\alpha}^{\pi+\alpha})$$

...

$$V_{dc} = \frac{2V_m}{\pi} \cos \alpha; \quad 0 < \alpha < \pi$$

- $V_{dc}$  can be varied from  $\frac{2V_m}{\pi}$  to  $\frac{-2V_m}{\pi}$  by varying  $\alpha$  from 0 to  $\pi$ .

- The **root-mean-square** of the output voltage is:

$$V_{rms} = \sqrt{\frac{2}{2\pi} \int_{\alpha}^{\pi+\alpha} (V_m \sin \omega t)^2 \, d\omega t}$$

$$V_{rms} = \sqrt{\frac{(V_m)^2}{2\pi} \int_{\alpha}^{\pi+\alpha} (1 - \cos 2\omega t) \, d\omega t}$$

...

$$V_{rms} = \frac{V_m}{\sqrt{2}}$$

- $V_{rms}$  is independent of  $\alpha$ !
- If the load is purely resistive, then the load current falls to zero at  $\omega t = \pi$ , and, consequently,  $T_1$  and  $T_2$  turn off. Also, at  $\omega t = 2\pi$ , the load current falls to zero, and hence  $T_3$  and  $T_4$  turn off. **Consequently, the output voltage cannot be negative!**
- The instantaneous output voltage of a Full-Converter supplying a purely resistive load is the same as that of a Semi-Converter.
- Therefore, the **values of the average output voltage and its rms value of a Full-Converter supplying a resistive load are the same as those of a Semi-Converter.**
- If four quadrants of operation is required, then two Full-Converters connected back-to-back (opposite to each other) are used in a configuration called a **Dual Converter**, as illustrated in the Figures below.

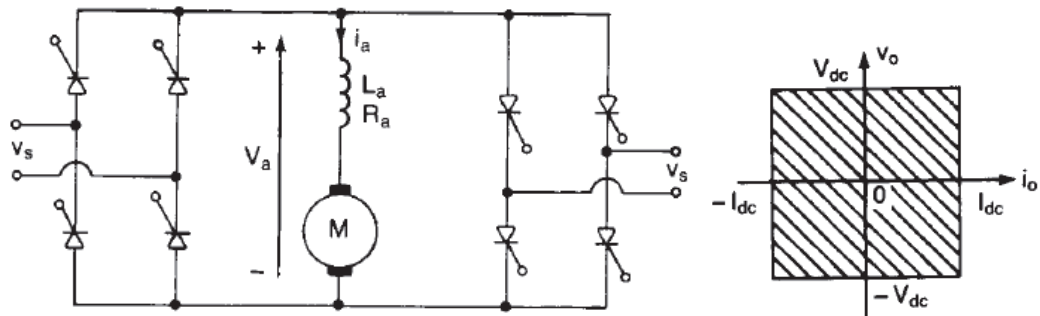

## Three-Phase Half-Wave Converters

- The circuit topology of a Three-Phase Half-Wave Converter feeding a Highly Inductive Load is shown in the Figure below.

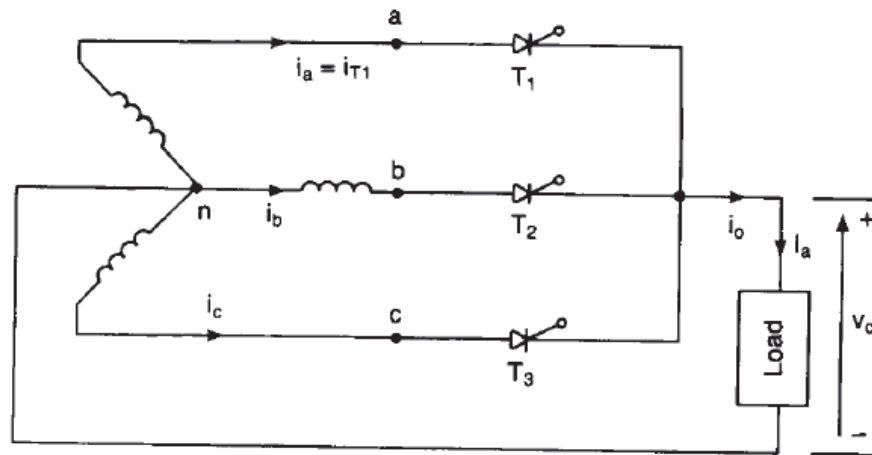

- It can be considered as three Single-Phase Half-Wave Converters.
- Because the load is highly inductive, the output current is ripple-free and constant over the whole cycle.
- Since the available current paths are through the Thyristors, each Thyristor has to conduct for  $120^\circ$  ( $\frac{1}{3}$  a cycle).
- For a successful turn-on of any Thyristor, the SCR has to be **forward biased**, triggered by a **pulse of gate current of sufficient width**, and its **Anode current must rise above the Latching current** during the gate pulse period.
- Any SCR becomes forward biased during the period within which it is connected to the highest voltage in the circuit.
- The waveforms of the Figure on the next page show that  $v_{an}$  becomes the highest voltage in the circuit at  $= \frac{\pi}{6}$ , thus  $T_1$  becomes forward biased.
- Besides, the waveforms show that  $v_{bn}$  starts to become the highest voltage in the circuit at an angle  $\omega t = \frac{5\pi}{6}$ , at which  $T_2$  starts to become forward biased. On the other hand,  $v_{cn}$  starts to become the highest voltage in the circuit at an angle  $= \frac{9\pi}{6}$ , forward biasing  $T_3$ . Therefore, the turn-on of any Thyristor can be delayed, via the Synchronizing and Triggering (Control) Circuit, for an angle ' $\alpha$ ', once that Thyristor has become forward biased. i.e.,

$T_1$  is triggered at  $\omega t = \frac{\pi}{6} + \alpha$ ,  $T_2$  is triggered at  $\omega t = \frac{5\pi}{6} + \alpha$ , and  $T_3$  is triggered at  $\omega t = \frac{9\pi}{6} + \alpha$



The gate signals and the corresponding voltage and current waveforms are shown in the Figure next.

The waveforms shown are for  $\alpha = \frac{\pi}{3}$ .

Note that, the frequency of the ripple at the output is  $3f$ .

The average output voltage is:

$$V_{dc} = \frac{3}{2\pi} \int_{\frac{\pi}{6} + \alpha}^{\frac{5\pi}{6} + \alpha} V_m \sin \omega t \, d\omega t$$

$$V_{dc} = \frac{3V_m}{2\pi} \left( -\cos \omega t \Big|_{\frac{\pi}{6} + \alpha}^{\frac{5\pi}{6} + \alpha} \right)$$

$$V_{dc} = \frac{3V_m}{2\pi} \left( \cos \left( \frac{\pi}{6} + \alpha \right) - \cos \left( \frac{5\pi}{6} + \alpha \right) \right)$$

Using the trigonometric identity:  $\cos(A + B) = \cos A \cos B - \sin A \sin B$

yields, 
$$V_{dc} = \frac{3V_m}{2\pi} \left( \cos \left( \frac{\pi}{6} \right) \cos(\alpha) - \sin \left( \frac{\pi}{6} \right) \sin(\alpha) - \cos \left( \frac{5\pi}{6} \right) \cos(\alpha) + \sin \left( \frac{5\pi}{6} \right) \sin(\alpha) \right)$$

$$\Rightarrow V_{dc} = \frac{3V_m}{2\pi} \left( \frac{\sqrt{3}}{2} \cos(\alpha) - \frac{1}{2} \sin(\alpha) + \frac{\sqrt{3}}{2} \cos(\alpha) + \frac{1}{2} \sin(\alpha) \right)$$

$$\therefore V_{dc} = \frac{3\sqrt{3}V_m}{2\pi} \cos(\alpha); \quad 0 < \alpha < \pi$$

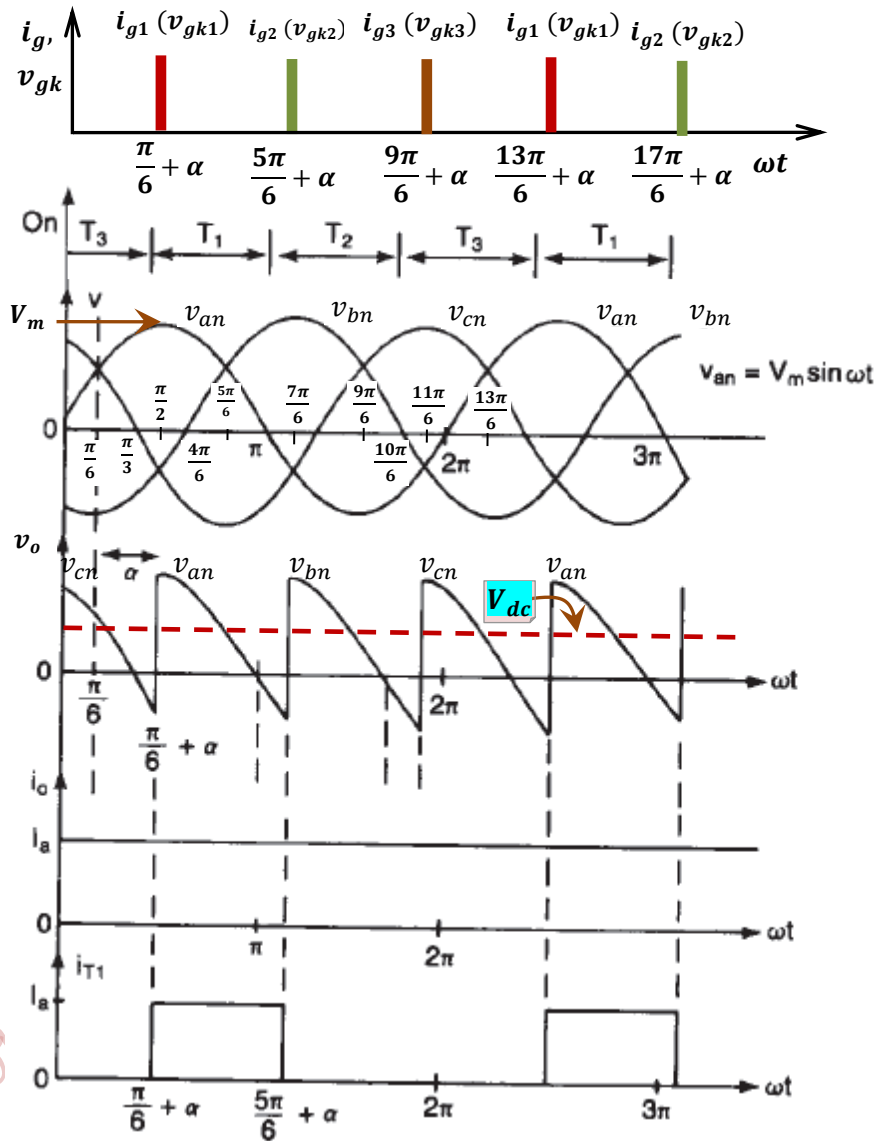

- At  $\alpha = 0$ , the average voltage  $V_{dc} = \frac{3\sqrt{3}V_m}{2\pi}$ , which is the same as that with q-Phase Star Rectifier,  $V_{dc} = \frac{qV_m}{\pi} \sin\left(\frac{\pi}{q}\right)$ , but with  $q = 3$ ! Note that,  $V_{dc}$  can be varied from  $\frac{3V_m\sqrt{3}}{\pi}$  to 0 by varying  $\alpha$  from 0 to  $\pi$ .
- The **root-mean-square** of the output voltage is:

$$V_{rms} = \sqrt{\frac{3}{2\pi} \int_{\frac{\pi}{6}+\alpha}^{\frac{5\pi}{6}+\alpha} (V_m \sin \omega t)^2 d\omega t}$$

...

$$V_{rms} = \sqrt{3}V_m \sqrt{\left(\frac{1}{6} + \frac{\sqrt{3}}{8\pi} \cos(2\alpha)\right)}; \quad 0 < \alpha < \pi$$

$V_{rms}$  depends on  $\alpha$ !

- In the case of a Highly Inductive load, this converter provides two quadrants of operation.

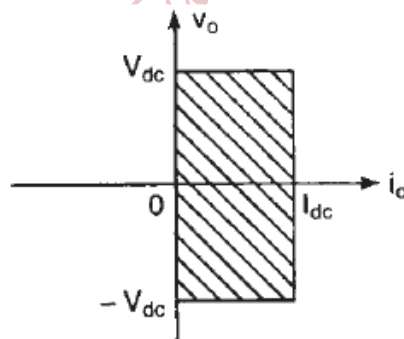

- If the load was **purely resistive, the output current has the same wave-shape as that of the output voltage, which can never have negative parts.** Thus, for  $\alpha > \frac{\pi}{6}$ , since the output current cannot be negative, the output voltage is discontinuous with no negative, as seen in the Figure below!

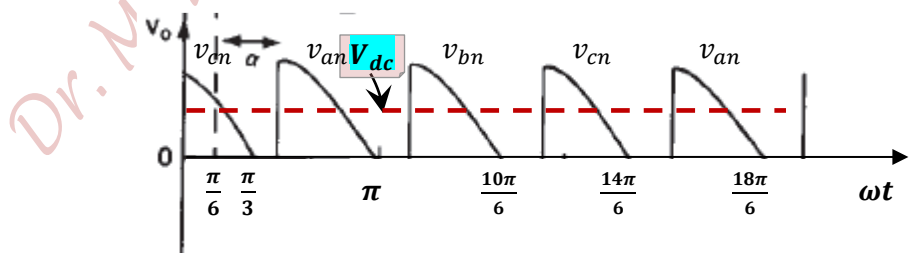

- In the case of a resistive load, each Thyristor is self-commutated as its current falls below its Holding value when its input phase voltage is falling to zero.

- The average output voltage is:

$$V_{dc} = \frac{3}{2\pi} \int_{\frac{\pi}{6} + \alpha}^{\pi} V_m \sin \omega t \, d\omega t$$

...

$$V_{dc} = \frac{3V_m}{2\pi} \left( 1 + \cos \left( \frac{\pi}{6} + \alpha \right) \right); \quad \frac{\pi}{6} < \alpha < \frac{5\pi}{6}$$

- The **root-mean-square** of the output voltage is:

$$V_{rms} = \sqrt{\frac{3}{2\pi} \int_{\frac{\pi}{6} + \alpha}^{\pi} (V_m \sin \omega t)^2 \, d\omega t}$$

...

$$V_{rms} = \sqrt{3} V_m \sqrt{\left( \frac{5}{24} - \frac{\alpha}{4\pi} + \frac{1}{8\pi} \sin \left( \frac{\pi}{3} + 2\alpha \right) \right)}$$

- If the load was purely resistive but  $\alpha < \frac{\pi}{6}$ ,** then the output voltage is continuous and has the same average value as that with a Highly Inductive Load. The same argument is valid also for the RMS value of the output voltage!

### Example 4-6

A three-phase half-wave converter in Fig. 4-7a is operated from a three-phase Y-connected 208-V 60-Hz supply and the load resistance is  $R = 10 \Omega$ . If it is required to obtain an average output voltage of 50% of the maximum possible output voltage, calculate the (a) delay angle  $\alpha$ ; (b) rms and average output currents; (c) average and rms thyristor currents; (d) rectification efficiency; (e) transformer utilization factor, TUF; and (f) input power factor, PF.

**Solution** The phase voltage is  $V_s = 208/\sqrt{3} = 120.1 \text{ V}$ ,  $V_m = \sqrt{2} V_s = 169.83 \text{ V}$ ,  $V_n = 0.5$ , and  $R = 10 \Omega$ . The maximum output voltage is

$$V_{dm} = \frac{3 \sqrt{3} V_m}{2\pi} = 3 \sqrt{3} \times \frac{169.83}{2\pi} = 140.45 \text{ V}$$

The average output voltage,  $V_{dc} = 0.5 \times 140.45 = 70.23 \text{ V}$ .

(a) For a resistive load, the load current is continuous if  $\alpha \leq \pi/6$  and Eq. (4-52) gives  $V_n \geq \cos(\pi/6) = 86.6\%$ . With a resistive load and 50% output, the load current is discontinuous. From Eq. (4-52a),  $0.5 = (1/\sqrt{3}) [1 + \cos(\pi/6 + \alpha)]$  and the delay angle is  $\alpha = 67.7^\circ$ .

(b) The average output current,  $I_{dc} = V_{dc}/R = 70.23/10 = 7.02 \text{ A}$ . From Eq. (4-53a),  $V_{rms} = 94.74 \text{ V}$  and the rms load current,  $I_{rms} = 94.74/10 = 9.47 \text{ A}$ .

(c) The average current of a thyristor,  $I_{DT} = I_{dc}/3 = 7.02/3 = 2.34 \text{ A}$  and the rms current of a thyristor,  $I_{RT} = I_{rms}/\sqrt{3} = 9.47/\sqrt{3} = 5.47 \text{ A}$ .

(d) From Eq. (2-44) the rectification efficiency is  $= 70.23 \times 7.02/(94.74 \times 9.47) = 54.95\%$ .

(e) The rms input line current is the same as the thyristor rms current, and the input volt-ampere rating,  $VI = 3V_s I_s = 3 \times 120.1 \times 5.47 = 1970.84 \text{ VA}$ . From Eq. (2-49),  $\text{TUF} = 70.23 \times 7.02/1970.84 = 0.25$  or 25%.

(f) The output power,  $P_o = I_{rms}^2 R = 9.47^2 \times 10 = 896.81 \text{ W}$ . The input power factor,  $\text{PF} = 896.81/1970.84 = 0.455$  (lagging).

*Note.* Due to the delay angle,  $\alpha$ , the fundamental component of input line current is also delayed with respect to the input phase voltage.

Dr.

### Three-Phase Semi-Converters

- The circuit topology of a Three-Phase Semi-Converter feeding a Highly Inductive Load is shown in the Figure below.

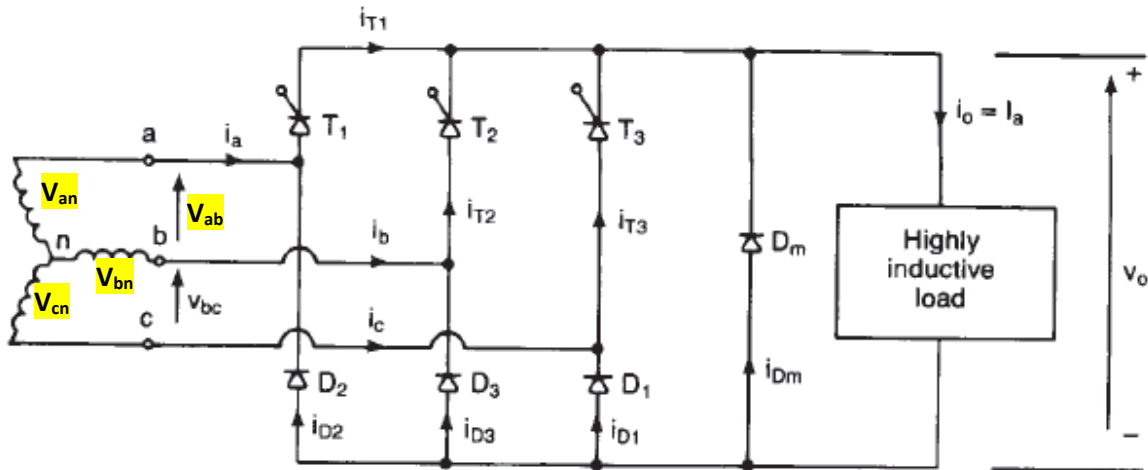

- The reference angle for the Firing (Delay) angle ( $\alpha$ ) of any Thyristor is the angle where that Thyristor becomes forward biased; when the input voltage connected to that SCR starts to be the highest voltage in the circuit, i.e.,

$$T_1 \text{ is triggered at } \omega t = \frac{\pi}{6} + \alpha, T_2 \text{ is triggered at } \omega t = \frac{5\pi}{6} + \alpha, \text{ and } T_3 \text{ is triggered at } \omega t = \frac{9\pi}{6} + \alpha$$

- The corresponding waveforms for  $\alpha = \frac{\pi}{2}$  are shown in the Figure of next page.
- $\alpha$  can be varied from 0 to  $\pi$ , that is because the turn-on of any SCR can be delayed as long as its voltage is still higher than the voltage connected to the preceding conducting SCR in the sequence ( $T_3 \Rightarrow T_1 \Rightarrow T_2 \Rightarrow T_3 \Rightarrow T_1 \Rightarrow \dots$ ). Turn-on of  $T_1$  can be delayed over the period where  $v_{an}$  is greater than  $v_{cn}$ , and Turn-on of  $T_2$  can be delayed over the period where  $v_{bn}$  is greater than  $v_{an}$ , and so on...

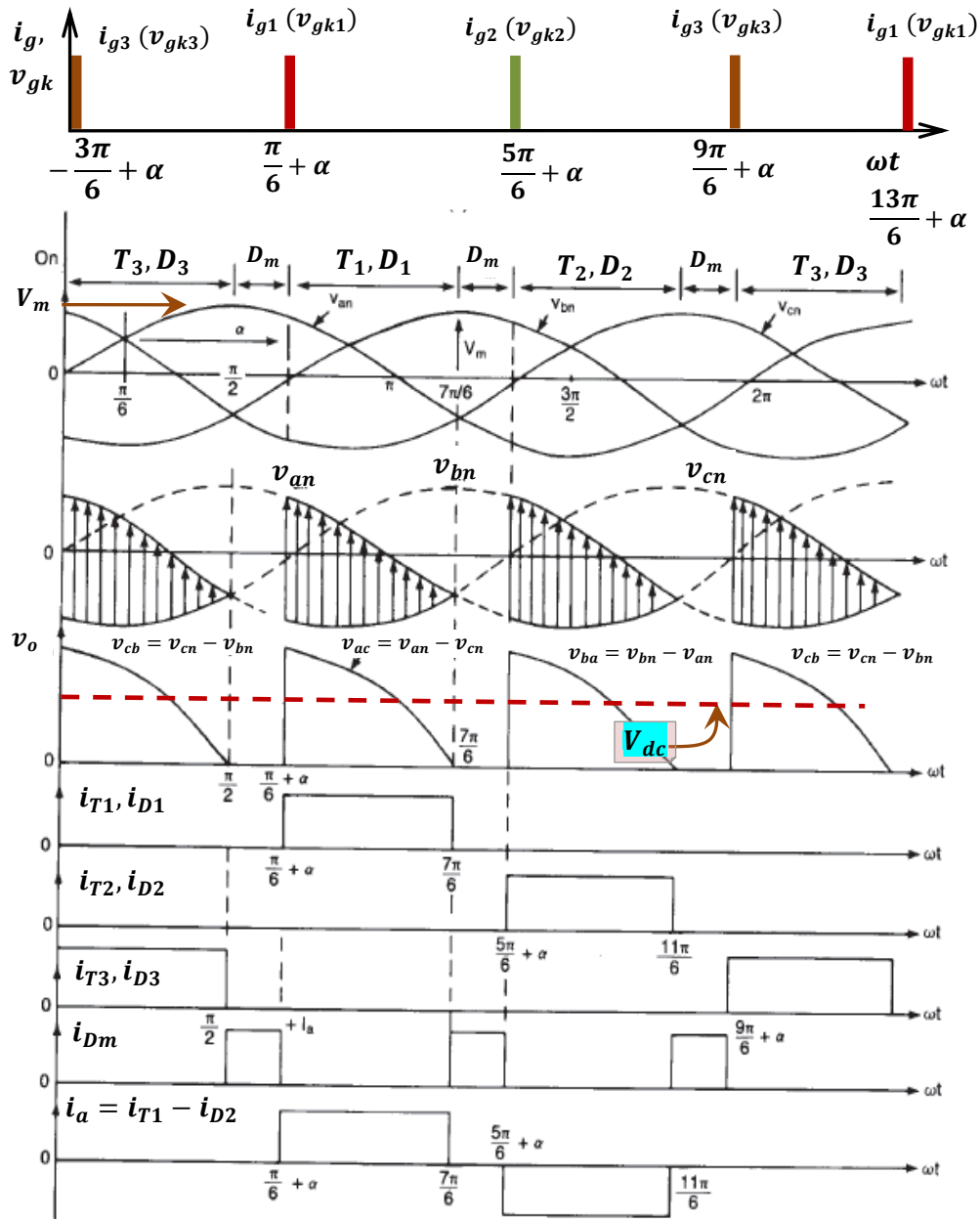

- Applying a pulse of current to the gate of  $T_1$  at  $\omega t = \frac{\pi}{6} + \alpha$  ( $\omega t = \frac{\pi}{6} + \frac{\pi}{2} = \frac{4\pi}{6}$ ) triggers  $T_1$  on, as it is forward biased. Therefore, the current commutates to  $T_1$ , flowing through the load and returning via the forward biased diode at the lower level of the converter.
- At the lower level of the converter, the diode connected to the lowest voltage in the circuit is forward biased.

- In this case, the Diode  $D_1$  is forward biased and thus the current flows back to the source via  $D_1$ . Therefore, the output voltage is the line-to-line voltage  $v_{ac}$ .
- At  $\omega t = \frac{7\pi}{6}$ , the Freewheeling Diode ( $D_m$ ) becomes forward biased ( $v_{ac}$  is about to reverse polarity), and hence  $D_m$  conducts allowing the load current to circulate within it! Also, at this angle, the conducting diode ( $D_1$ ) becomes reversed biased, and hence it turns off.
- The current commutates from  $T_1$  to  $D_m$ , therefore  $T_1$  turns off as its current falls below the Holding current.
- Applying a pulse of current to the gate of  $T_2$  at  $\omega t = \frac{5\pi}{6} + \alpha$  ( $\omega t = \frac{5\pi}{6} + \frac{\pi}{2} = \frac{8\pi}{6}$ ) triggers  $T_2$  on, as it is forward biased, and applies a reverse voltage ( $v_{ba}$ ) across the Freewheeling Diode ( $D_m$ ), which turns off.
- Therefore, the current commutates from  $D_m$  to  $T_2$ , flowing through the load and returning to the source via the forward biased diode in this period, which is Diode  $D_2$ .
- The triggering sequence continues, and the load current flows alternatively between a Diode-SCR pair and  $D_m$ .
- Note that, when a Diode-SCR pair is conducting, the output voltage is the respective line-to-line voltage, whilst the output voltage is zero (assuming an ideal diode) when the Freewheeling Diode ( $D_m$ ) is conducting.
- Note also that, if there was no Freewheeling Diode ( $D_m$ ), then the 'on' Thyristor would stay conductive as its current is greater than the Holding current. However, when the voltage applied to that SCR becomes the lowest voltage in the circuit, the diode forming the same converter leg with the SCR becomes forward biased and the load current circulates in that converter leg instead of  $D_m$ . The conduction power loss is higher in this case; two conducting devices instead of one. The current circulation continues until the next SCR in the sequence is triggered.
- To find the average output voltage of the Semi-Converter, assume that the phase voltages are:

$$v_{an} = V_m \sin \omega t$$

$$v_{bn} = V_m \sin \left( \omega t - \frac{2\pi}{3} \right)$$

$$v_{cn} = V_m \sin \left( \omega t + \frac{2\pi}{3} \right)$$

Then, the corresponding line-to-line voltages are:

$$v_{ab} = \sqrt{3}V_m \sin \left( \omega t + \frac{\pi}{6} \right)$$

$$v_{ac} = \sqrt{3}V_m \sin \left( \omega t - \frac{\pi}{6} \right)$$

Thus, for  $\alpha > \frac{\pi}{3}$  and discontinuous output voltage, the average output voltage is:

$$V_{dc} = \frac{3}{2\pi} \int_{\frac{\pi}{6}+\alpha}^{\frac{7\pi}{6}} v_{ac} d\omega t$$

$$V_{dc} = \frac{3}{2\pi} \int_{\frac{\pi}{6}+\alpha}^{\frac{7\pi}{6}} \sqrt{3}V_m \sin\left(\omega t - \frac{\pi}{6}\right) d\omega t$$

$$V_{dc} = \frac{3\sqrt{3}V_m}{2\pi} \left(-\cos\left(\omega t - \frac{\pi}{6}\right)\right) \Big|_{\frac{\pi}{6}+\alpha}^{\frac{7\pi}{6}}$$

...

$$V_{dc} = \frac{3\sqrt{3}V_m}{2\pi} (1 + \cos \alpha); \quad \frac{\pi}{3} \leq \alpha \leq \pi$$

For  $\alpha > \frac{\pi}{3}$  and discontinuous output voltage, the root-mean-square of the output voltage is:

$$V_{rms} = \sqrt{\frac{3}{2\pi} \int_{\frac{\pi}{6}+\alpha}^{\frac{7\pi}{6}} (v_{ac})^2 d\omega t}$$

$$V_{rms} = \sqrt{\frac{3}{2\pi} \int_{\frac{\pi}{6}+\alpha}^{\frac{7\pi}{6}} \left(\sqrt{3}V_m \sin\left(\omega t - \frac{\pi}{6}\right)\right)^2 d\omega t}$$

...

$$V_{rms} = \sqrt{3}V_m \sqrt{\frac{3}{4\pi} \left(\pi - \alpha + \frac{\sin 2\alpha}{2}\right)}; \quad \frac{\pi}{3} \leq \alpha \leq \pi$$



- If  $\alpha \leq \frac{\pi}{3}$ , each SCR conducts for  $\frac{2\pi}{3}$  and the output voltage is continuous and there will be no Freewheeling Diode action. The Figure below shows the waveforms for  $\alpha = \frac{\pi}{6}$ .

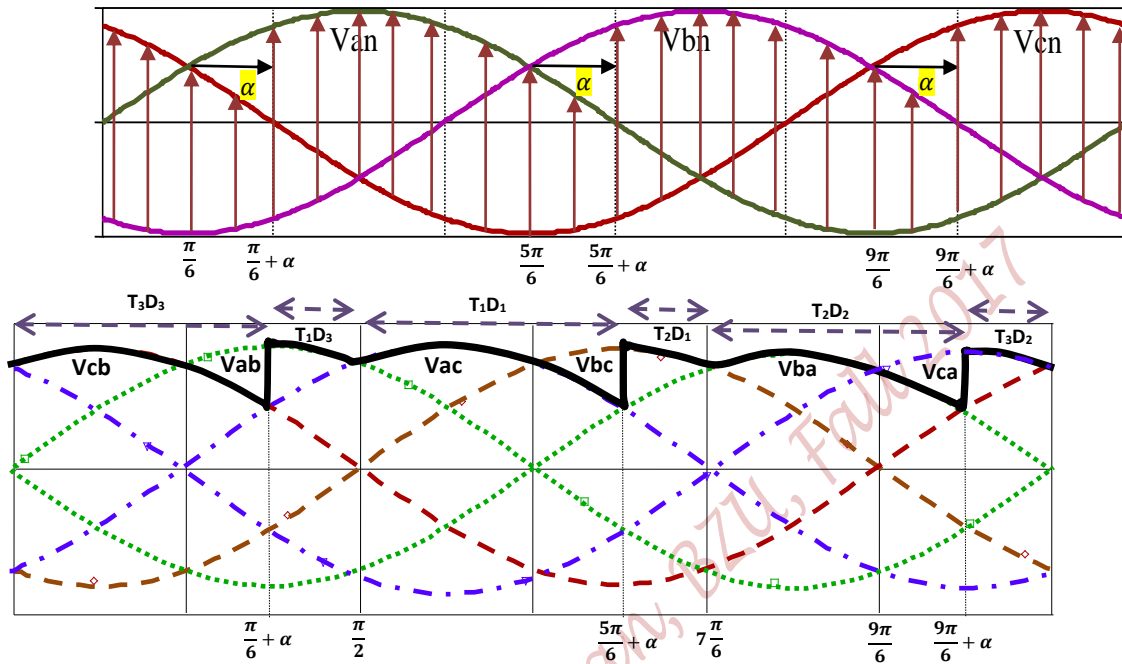

- If  $\alpha \leq \frac{\pi}{3}$ , then the average output voltage is:

$$V_{dc} = \frac{3}{2\pi} \left[ \int_{\frac{\pi}{6}+\alpha}^{\frac{\pi}{2}} v_{ab} d\omega t + \int_{\frac{\pi}{2}}^{\frac{5\pi}{6}+\alpha} v_{ac} d\omega t \right]$$

...

$$V_{dc} = \frac{3\sqrt{3}V_m}{2\pi} (1 + \cos \alpha); \quad \alpha \leq \frac{\pi}{3}$$

which is the same as that with  $\alpha > \frac{\pi}{3}$ !

- For  $\alpha \leq \frac{\pi}{3}$ , and continuous output voltage, the **root-mean-square** of the output voltage is:

$$V_{rms} = \sqrt{\frac{3}{2\pi} \left[ \int_{\frac{\pi}{6}+\alpha}^{\frac{\pi}{2}} (v_{ab})^2 d\omega t + \int_{\frac{\pi}{2}}^{\frac{5\pi}{6}+\alpha} (v_{ac})^2 d\omega t \right]}$$

...

$$V_{rms} = \sqrt{3}V_m \sqrt{\frac{3}{4\pi} \left( \frac{2\pi}{3} + \sqrt{3}(\cos \alpha)^2 \right)}, \quad \text{which is different from that with } \alpha > \frac{\pi}{3} !$$

### Example 4-7

Repeat Example 4-6 for the three-phase **Semi Converter** in Fig. 4-8a.

**Solution** The phase voltage is  $V_s = 208/\sqrt{3} = 120.1$  V,  $V_m = \sqrt{2} V_s = 169.83$ ,  $V_n = 0.5$ , and  $R = 10 \Omega$ . The maximum output voltage is

$$V_{dm} = \frac{3\sqrt{3} V_m}{\pi} = 3\sqrt{3} \times \frac{169.83}{\pi} = 280.9 \text{ V}$$

The average output voltage,  $V_{dc} = 0.5 \times 280.9 = 140.45$  V.

(a) For  $\alpha \geq \pi/3$  and Eq. (4-55) gives  $V_n \leq (1 + \cos \pi/3)/2 = 75\%$ . With a resistive load and 50% output, the output voltage is discontinuous. From Eq. (4-55),  $0.5 = 0.5(1 + \cos \alpha)$ , which gives the delay angle,  $\alpha = 90^\circ$ .

(b) The average output current,  $I_{dc} = V_{dc}/R = 140.45/10 = 14.05$  A. From Eq. (4-56),

$$V_{rms} = \sqrt{3} \times 169.83 \left[ \frac{3}{4\pi} \left( \pi - \frac{\pi}{2} + 0.5 \sin 2 \times 90^\circ \right) \right]^{1/2} = 180.13 \text{ V}$$

and the rms load current,  $I_{rms} = 180.13/10 = 18.01$  A.

(c) The average current of a thyristor,  $I_{DT} = I_{dc}/3 = 14.05/3 = 4.68$  A and the rms current of a thyristor,  $I_{RT} = I_{rms}/\sqrt{3} = 18.01/\sqrt{3} = 10.4$  A.

(d) From Eq. (2-44) the rectification efficiency is

$$\eta = \frac{140.45 \times 14.05}{180.13 \times 18.01} = 0.688 \text{ or } 68.8\%$$

(e) The rms input line current is  $I_s = I_{rms} \sqrt{2/3} = 14.71$  A. The input volt-ampere rating,  $VI = 3V_s I_s = 3 \times 120.1 \times 14.71 = 5300$ . From Eq. (2-49),  $TUF = 140.45 \times 14.05/5300 = 0.372$ .

(f) The output power,  $P_o = I_{rms}^2 R = 18.01^2 \times 10 = 3243.6$  W. The power factor is  $PF = 3243.6/5300 = 0.612$  (lagging).

*Note.* The power factor is better than that of three-phase half-wave converters.

## Three-Phase Full-Converters

- The circuit topology of a Three-Phase Full-Wave Controlled Rectifier supplying a Highly Inductive Load is shown in the Figure below.

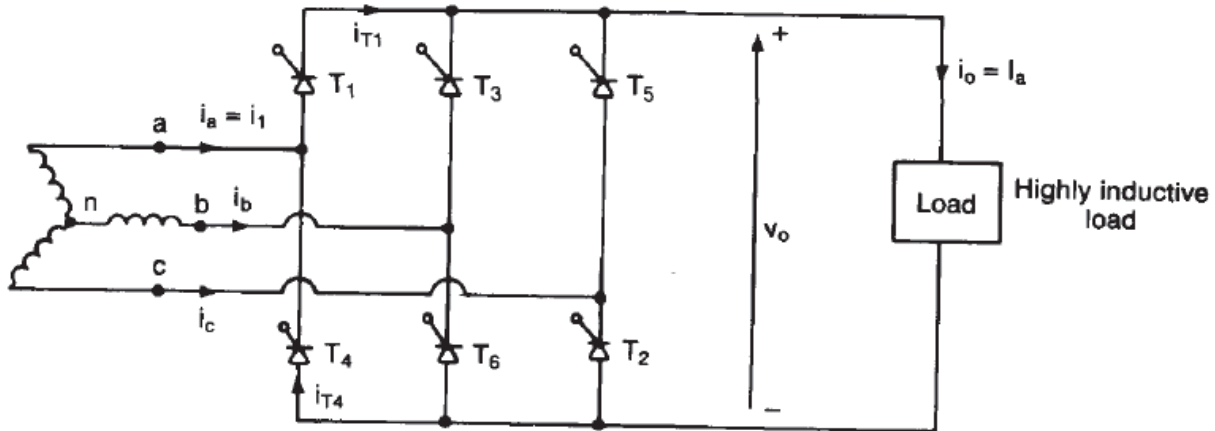

- The numbering sequence of the Thyristors is the conventional numbering sequence implemented in any other three phase converter.
- The phase shift between any two consequent Thyristors is  $60^\circ$  (or  $\frac{\pi}{3}$ );  
 $T_1$  is triggered at  $\omega t = \frac{\pi}{6} + \alpha$ ,  $T_2$  is triggered at  $\omega t = \frac{\pi}{2} + \alpha$ , and  $T_3$  is triggered at  $\omega t = \frac{5\pi}{6} + \alpha$   
 $T_4$  is triggered at  $\omega t = \frac{7\pi}{6} + \alpha$ ,  $T_5$  is triggered at  $\omega t = \frac{9\pi}{6} + \alpha$ , and  $T_6$  is triggered at  $\omega t = \frac{11\pi}{6} + \alpha$
- At any time, there are two conducting Thyristors; one SCR at the top level and another SCR at the bottom level of the converter.
- The conduction sequence of the Thyristors is:  $T_1T_2, T_2T_3, T_3T_4, T_4T_5, T_5T_6, T_6T_1, T_1T_2, T_2T_3, \dots$

- The waveforms for  $\alpha = \frac{\pi}{3}$  are shown in the Figure below.

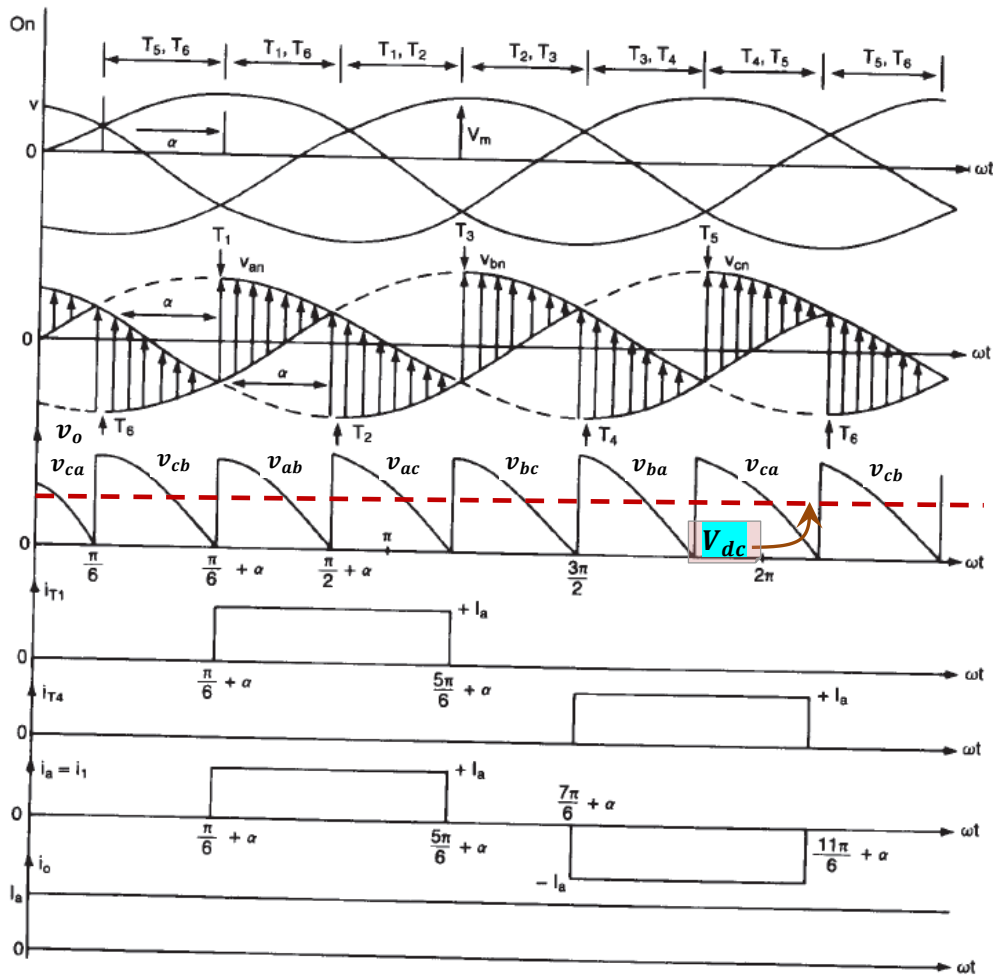

- When  $T_2$  is triggered (at  $\omega t = \frac{\pi}{2} + \alpha$ ),  $T_6$  becomes reverse biased and turns off due to natural (or line) commutation as its Anode current falls below its Holding value, commutating to  $T_2$ .
- Note that, the frequency of the ripple at the output is  $6f$ , where  $f$  is the supply frequency.
- If the phase voltages are:

$$v_{an} = V_m \sin \omega t$$

$$v_{bn} = V_m \sin \left( \omega t - \frac{2\pi}{3} \right)$$

$$v_{cn} = V_m \sin \left( \omega t + \frac{2\pi}{3} \right)$$

Then, the corresponding line-to-line voltages are:

$$v_{ab} = \sqrt{3}V_m \sin \left( \omega t + \frac{\pi}{6} \right)$$

$$v_{ac} = \sqrt{3}V_m \sin \left( \omega t - \frac{\pi}{6} \right)$$

- The **average output voltage** is:

$$V_{dc} = \frac{6}{2\pi} \int_{\frac{\pi}{6}+\alpha}^{\frac{\pi}{2}+\alpha} v_{ab} d\omega t$$

$$V_{dc} = \frac{3}{\pi} \int_{\frac{\pi}{6}+\alpha}^{\frac{\pi}{2}+\alpha} \sqrt{3}V_m \sin\left(\omega t + \frac{\pi}{6}\right) d\omega t$$

$$V_{dc} = \frac{3\sqrt{3}V_m}{\pi} \left(-\cos\left(\omega t + \frac{\pi}{6}\right)\right) \Big|_{\frac{\pi}{6}+\alpha}^{\frac{\pi}{2}+\alpha}$$

...

$$V_{dc} = \frac{3\sqrt{3}V_m}{\pi} \cos \alpha; \quad 0 \leq \alpha \leq \pi$$

- The **root-mean-square** of the output voltage is:

$$V_{rms} = \sqrt{\frac{6}{2\pi} \int_{\frac{\pi}{6}+\alpha}^{\frac{\pi}{2}+\alpha} (v_{ab})^2 d\omega t}$$

$$V_{rms} = \sqrt{\frac{3}{\pi} \int_{\frac{\pi}{6}+\alpha}^{\frac{\pi}{2}+\alpha} \left(\sqrt{3}V_m \sin\left(\omega t + \frac{\pi}{6}\right)\right)^2 d\omega t}$$

...

$$V_{rms} = \sqrt{3}V_m \sqrt{\left(\frac{1}{2} + \frac{3\sqrt{3}}{4\pi} \cos 2\alpha\right)}$$

- Since the average output voltage varies from  $\frac{3\sqrt{3}V_m}{\pi}$  to  $-\frac{3\sqrt{3}V_m}{\pi}$ , then two quadrants of operation are possible!

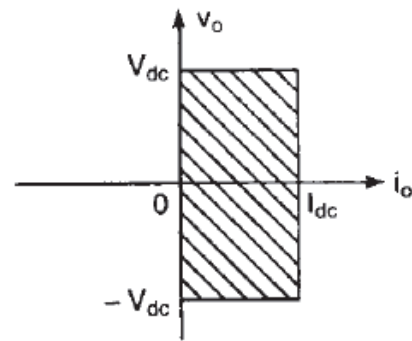

- Note that, for  $\alpha < \frac{\pi}{3}$  the output voltage is continuous and does not have any negative instantaneous value regardless of the load type (resistive or highly inductive). Thus, for  $\alpha < \frac{\pi}{3}$  and a **resistive load the average output voltage is the same as the average output voltage of a Highly Inductive Load.**

- For a Highly Inductive Load and  $\alpha > \frac{\pi}{3}$ , the instantaneous output voltage has negative parts. Thus, with a resistive load (and with  $\alpha > \frac{\pi}{3}$ ), the instantaneous output voltage cannot be negative (because the output current cannot be negative) and the average output voltage in the resistive load case is:

$$V_{dc} = \frac{6}{2\pi} \int_{\frac{\pi}{6}+\alpha}^{\frac{5\pi}{6}} v_{ab} d\omega t$$

$$V_{dc} = \frac{3}{\pi} \int_{\frac{\pi}{6}+\alpha}^{\frac{5\pi}{6}} \sqrt{3}V_m \sin\left(\omega t + \frac{\pi}{6}\right) d\omega t$$

$$V_{dc} = \frac{3\sqrt{3}V_m}{\pi} \left(-\cos\left(\omega t + \frac{\pi}{6}\right)\right) \Big|_{\frac{\pi}{6}+\alpha}^{\frac{5\pi}{6}}$$

...

$$V_{dc} = \frac{3\sqrt{3}V_m}{\pi} \left(1 + \cos\left(\alpha + \frac{\pi}{3}\right)\right); \quad \frac{\pi}{3} \leq \alpha \leq \frac{4\pi}{6}$$

- If the load is resistive, double pulse scheme for firing angles is implemented, as illustrated in the Figure next.

That is to ensure that the preceding Thyristor in the sequence is turned 'on', when the next Thyristor is triggered; to ensure that two Thyristors are turned-on to provide the needed current path!

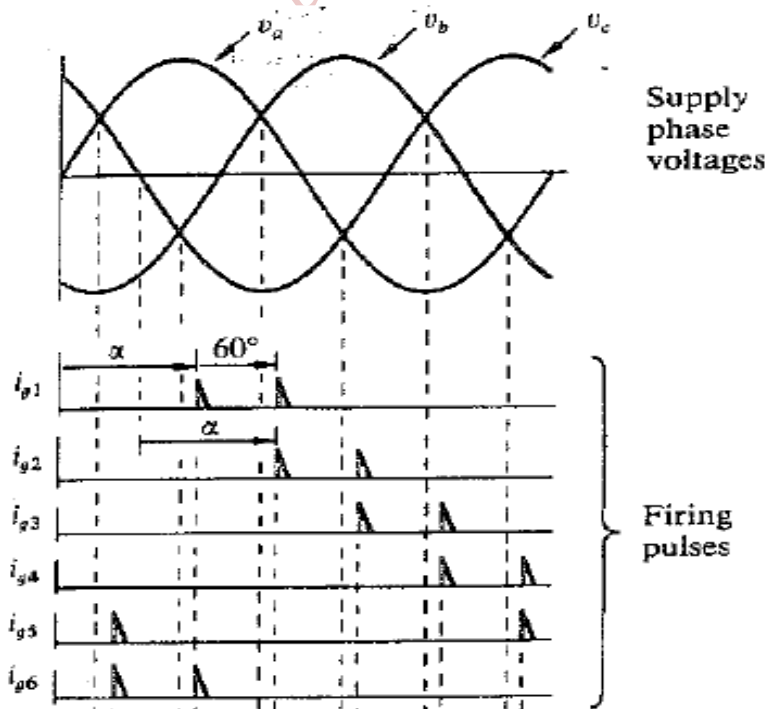

- To increase the frequency of the ripple at the output, two six-pulse bridges (converters) can be combined either in series or in parallel to produce an effective 12-pulse output. However, the input voltages to these individual converters must be out of phase by  $30^\circ$ .
- A  $30^\circ$  phase shift between transformers' secondary windings, feeding these individual converters, can be achieved by connecting one group of **secondaries in WYE and the other in Delta** (these secondaries are coupled to the same three-phase primary windings), as illustrated in the Figures below.

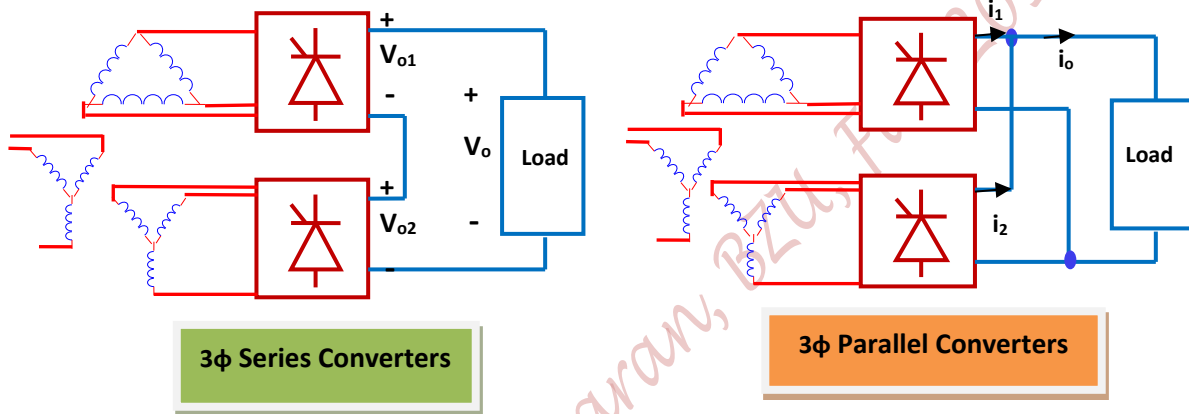

- Four quadrants of operation can be obtained by implementing a Dual Converter, shown below.

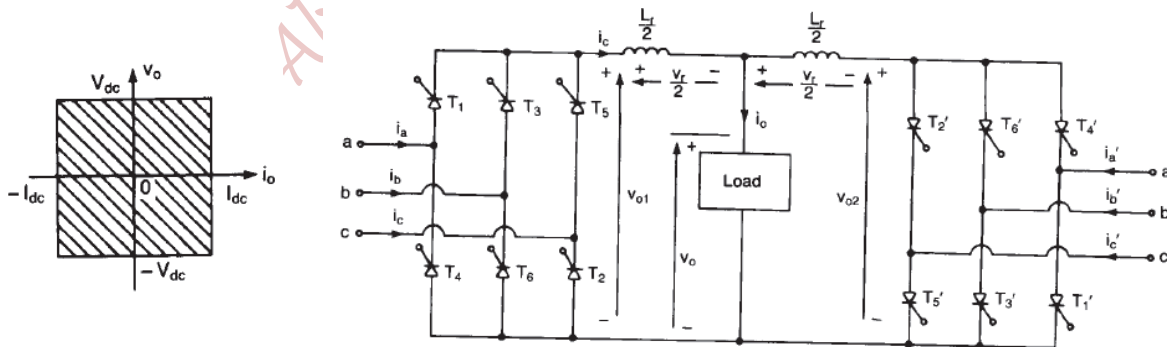

### Example 4-8

Repeat Example 4-6 for the three-phase full converter in Fig. 4-9a.

**Solution** The phase voltage,  $V_s = 208/\sqrt{3} = 120.1$  V,  $V_m = \sqrt{2} V_s = 169.83$ ,  $V_n = 0.5$ , and  $R = 10 \Omega$ . The maximum output voltage,  $V_{dm} = 3\sqrt{3} V_m/\pi = 3\sqrt{3} \times 169.83/\pi = 280.9$  V. The average output voltage,  $V_{dc} = 0.5 \times 280.9 = 140.45$  V.

(a) From Eq. (4-58),  $0.5 = \cos \alpha$ , and the delay angle,  $\alpha = 60^\circ$ .

(b) The average output current,  $I_{dc} = V_{dc}/R = 140.45/10 = 14.05$  A. From Eq. (4-59),

$$V_{rms} = \sqrt{6} \times 169.83 \left[ \frac{1}{4} + \frac{3\sqrt{3}}{8\pi} \cos(2 \times 60^\circ) \right]^{1/2} = 159.29 \text{ V},$$

and the rms current,  $I_{rms} = 159.29/10 = 15.93$  A.

(c) The average current of a thyristor,  $I_{DT} = I_{dc}/3 = 14.05/3 = 4.68$  A, and the rms current of a thyristor,  $I_{RT} = I_{rms} \sqrt{2/6} = 15.93 \sqrt{2/6} = 9.2$  A.

(d) From Eq. (2-44) the rectification efficiency is

$$\eta = \frac{140.45 \times 14.05}{159.29 \times 15.93} = 0.778 \text{ or } 77.8\%$$

(e) The rms input line current,  $I_s = I_{rms} \sqrt{4/6} = 13$  A and the input volt-ampere rating,  $VI = 3V_s I_s = 3 \times 120.1 \times 13 = 4683.9$  VA. From Eq. (2-49),  $TUF = 140.45 \times 14.05/4683.9 = 0.421$ .

(f) The output power,  $P_o = I_{rms}^2 R = 15.93^2 \times 10 = 2537.6$  W. The power factor,  $PF = 2537.6/4683.9 = 0.542$  (lagging).

*Note.* The power factor is less than that of three-phase semiconverters, but higher than that of three-phase half-wave converters.



## Power Factor Correction

### Techniques Used For Power Factor Correction:

- 1) Synchronous Condensers (old approach)
- 2) Parallel Capacitors
- 3) Power Electronic Circuits: Controlled Rectifiers, PWM Rectifiers, Voltage Source Converters, Current Source Converters, ...(recent approach)

### Power Factor Correction via Controlled Rectifiers:

Two main control strategies can be implemented to enable the Controlled Rectifier to operate as a Power Factor Correction Equipment; namely:

- 1- Extinction Angle Control
- 2- Symmetrical Angle Control

#### 1- Extinction Angle Control

Consider the Single-Phase Semi-Converter, which has switches ( $S_1$  and  $S_2$ ) with turn-off capability replacing the Thyristors (e.g. GTOs), supplying a Highly Inductive Load and is shown in the Figure below.

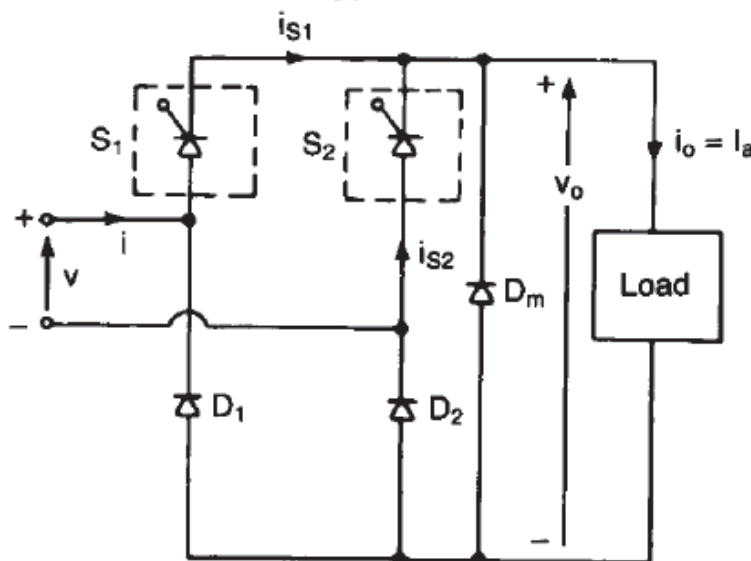

- ➔ In this method, the switch  $S_1$  is turned on at  $\omega t = 0$  and is turned off at an angle  $\omega t = \pi - \beta$ , whilst the switch  $S_2$  is turned on at  $\omega t = \pi$  and is turned off at an angle  $\omega t = 2\pi - \beta$ ; such that  $\beta$  is called the extinction angle.
- ➔ The output voltage is controlled by varying the extinction angle,  $\beta$ .

► The voltage and current waveforms of this Semi-Converter, implementing this method, are shown in the Figure below.

► The average output voltage is:

$$V_{dc} = \frac{2}{2\pi} \int_0^{\pi-\beta} V_m \sin \omega t \, d\omega t$$

...

$$V_{dc} = \frac{V_m}{\pi} (1 + \cos \beta)$$

► The root-mean-square value of the output voltage is:

$$V_{rms} = \sqrt{\frac{2}{2\pi} \int_0^{\pi-\beta} (V_m \sin \omega t)^2 \, d\omega t}$$

...

$$V_{rms} = \frac{V_m}{\sqrt{2}} \sqrt{\frac{1}{\pi} \left( \pi - \beta + \frac{\sin 2\beta}{2} \right)}$$

such that,  $0 < \beta < \pi$

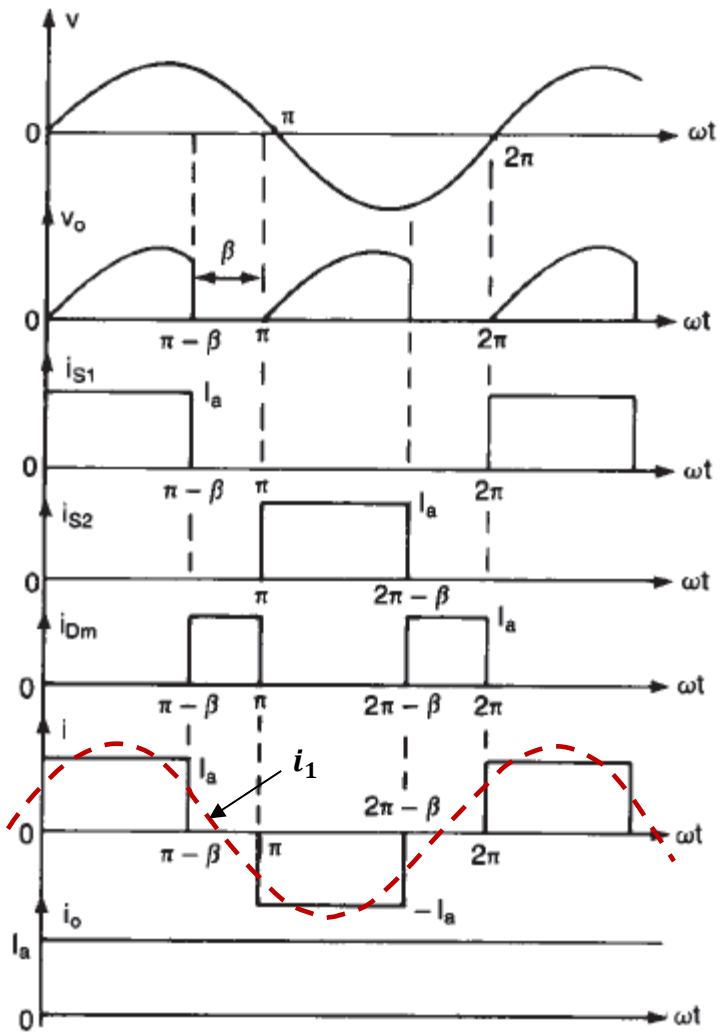

► The fundamental component of the input line current ( $i$ ), dashed line, leads the input voltage, and the Displacement Power Factor (Power Factor) is leading, depending of the value of extinction angle,  $\beta$ .

► The Extinction Angle Control can also be used Full-Wave Controlled Rectifier to improve the Displacement power Factor.

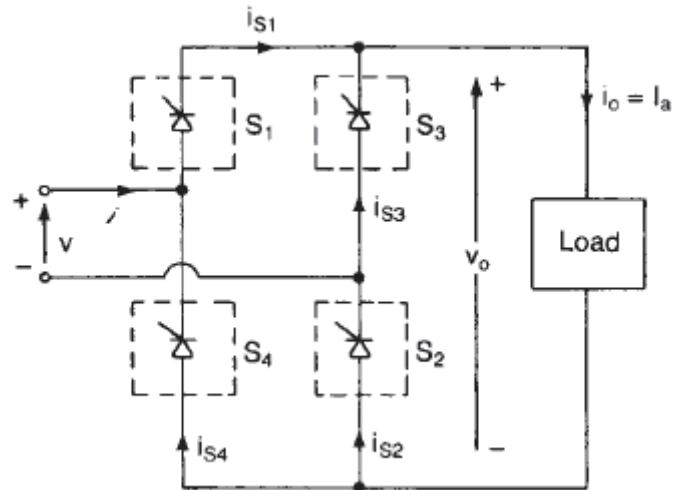

► In the Full-Wave Controlled Rectifier, shown in the Figure next, the turn-on and turn-off of the Controllable switches are controlled such that the input current has the same wave-shape as that with the Semi-Converter; the freewheeling action of the Inductive Load current is completed within each leg of the converter, alternatively, as clearly seen in the waveforms below!

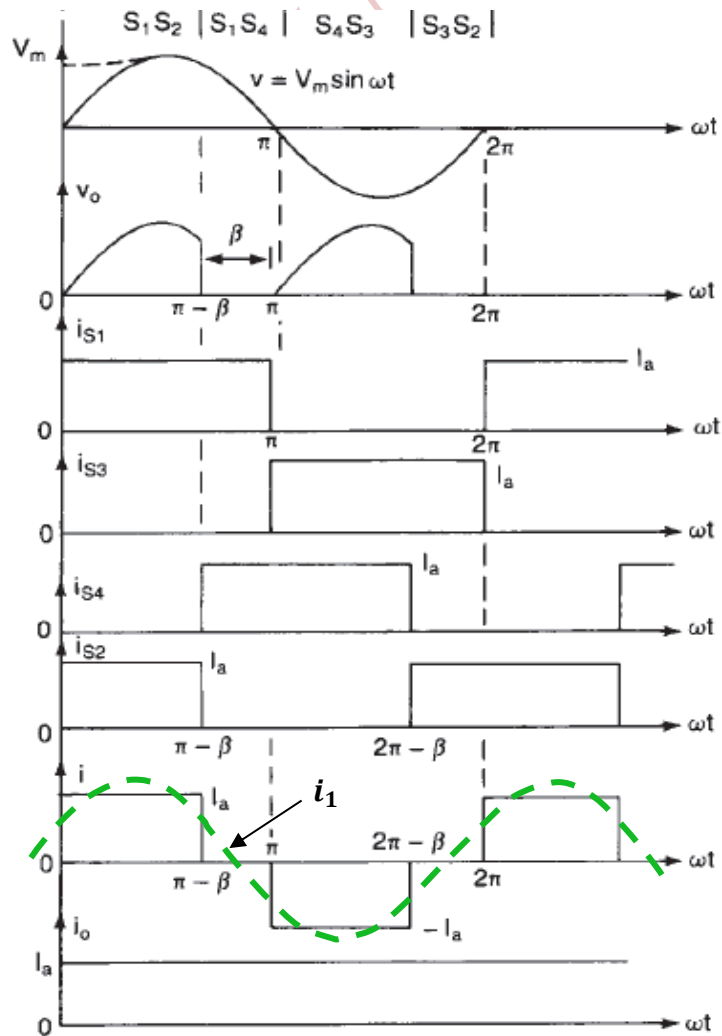

► The fundamental component of the input current,  $i_1$ , (dashed line), leads the input voltage and the Displacement Power Factor is leading; hence the Power Factor is improved!

## 2- Symmetrical Angle Control

- Reconsider the Single-Phase Semi-Converter, shown in the Figure below, applying switches instead of the Thyristors and implementing Symmetrical Angle Control.

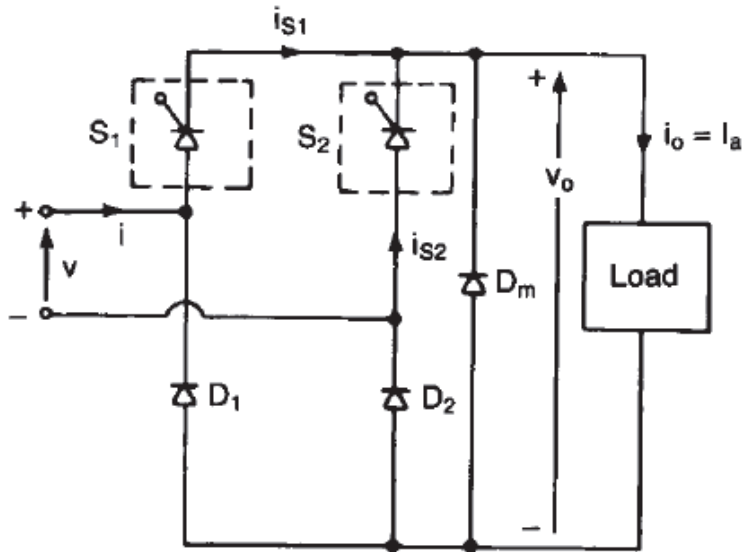

- In Symmetrical Angle Control method, the switch  $S_1$  is turned on at  $\omega t = \frac{\pi - \beta}{2}$  and is turned off at an angle  $\omega t = \frac{\pi + \beta}{2}$ , whilst the switch  $S_2$  is turned on at  $\omega t = \frac{3\pi - \beta}{2}$  and is turned off at an angle  $\omega t = \frac{3\pi + \beta}{2}$ ; such that  $\beta$  is called the Conduction angle.

The voltage and current waveforms are shown in the Figure below.

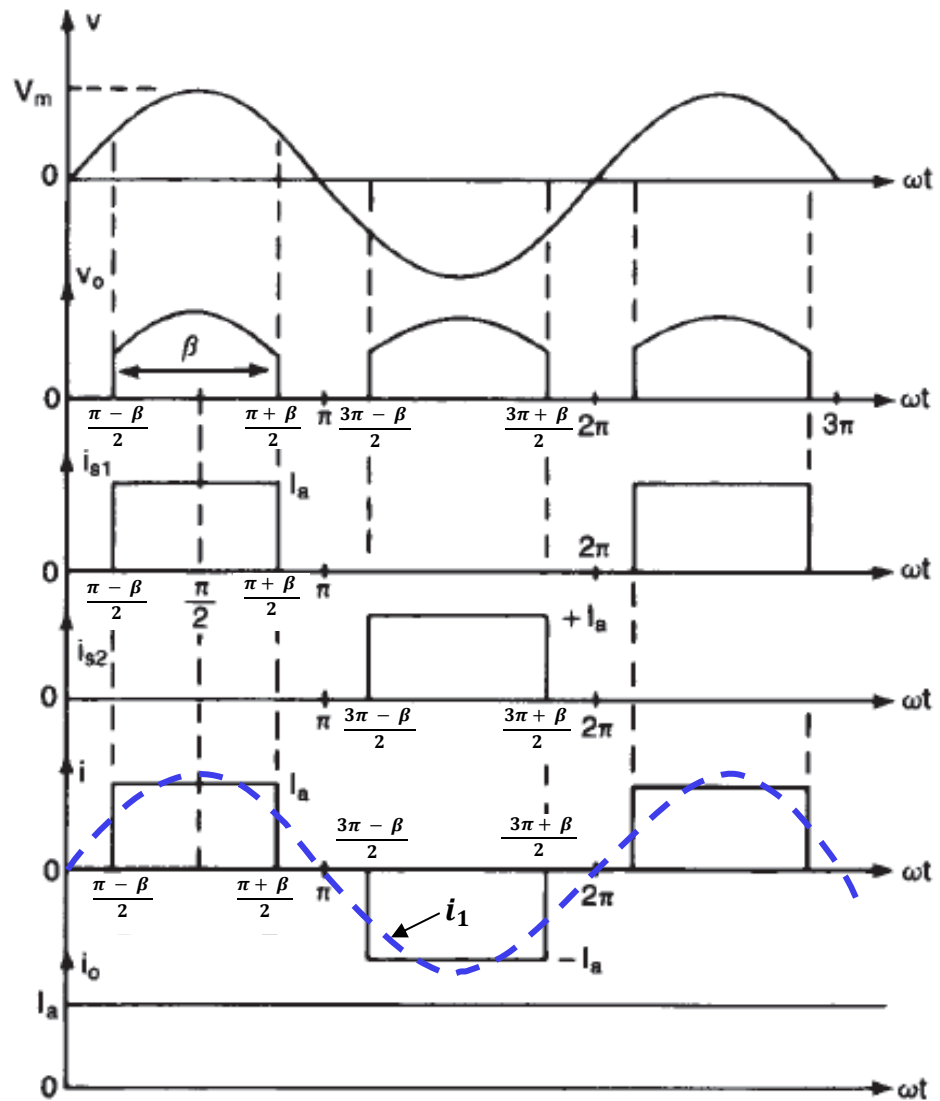

The Fundamental component of the input current,  $i_1$ , (dashed line) is in phase with the input voltage, and the Displacement Power Factor is unity; hence the Power Factor is improved!

The Symmetrical Angle Control can also be implemented in a Full-Wave Controlled Rectifier.

Dr. M. Abu-Khaizaran, BZU, Fall 2017

---

# Part IV: AC Voltage Controllers

---

An **AC Voltage Controller** provides an adjustable rms value of the output voltage. In some AC Voltage Controller configurations, the output frequency could also be controlled.

The output of these controllers consists of a fundamental (AC) component of the output voltage plus other (undesirable) AC components at higher frequencies called **harmonics**.

**Types of AC Voltage Controllers:**

- 1) Single Phase Controllers
- 2) Three Phase Controllers

**Two main Types of Control can be applied to AC Controllers:**

- I) On-Off Control
- II) Phase Angle Control

**The latter type can be classified as:**

- a) Unidirectional or Half-Wave Control
- b) Bidirectional or Full-Wave Control

## I) Principle of On-Off Control

✚ A Single Phase AC Voltage Controller implementing On-Off Control is shown in the Figure below.

✚ The Thyristor switch is “on” for a particular time  $t_n$  and is “off” for another time  $t_m$ .

✚ The Thyristors  $T_1$  and  $T_2$  could be a TRIAC if the latter has the required ratings!

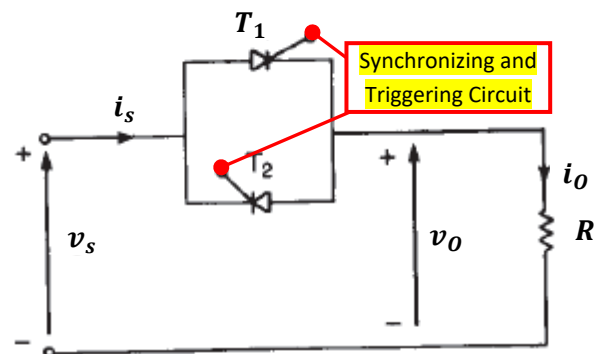

- The Synchronizing and Triggering Circuit synchronizes the Thyristors' gate signals with the supply voltage and applies an appropriate pulse of gate current and gate-cathode voltage for a proper turn-on of a particular SCR.
- The associated waveforms of this method are shown in the Figure below.

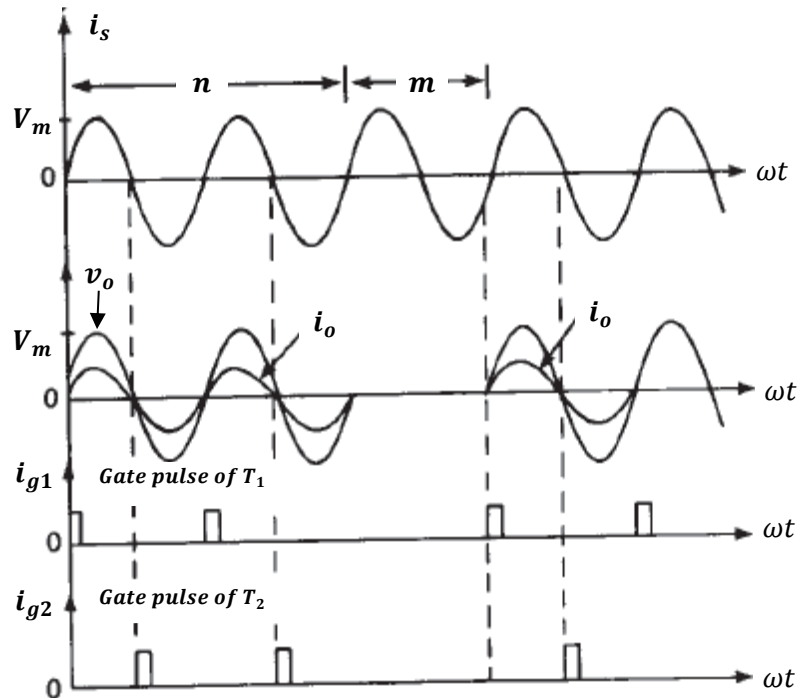

- "n" is an integral number of "on" cycles, whilst m is an integral number of "off" cycles.

- Since the load is connected to the supply for "n" cycles, and is disconnected for "m" cycles, then the rms value of the output voltage is:

$$V_{Orms} = \sqrt{\frac{n}{(n+m)2\pi} \int_0^{2\pi} (V_m \sin \omega t)^2 d\omega t}$$

$$V_{Orms} = \sqrt{\frac{n}{n+m} \sqrt{\frac{(V_m)^2}{4\pi} \int_0^{2\pi} (1 - \cos 2\omega t) d\omega t}}$$

...

$$V_{Orms} = \sqrt{\frac{n}{n+m}} V_s$$

$$V_{Orms} = \sqrt{k} V_s$$

where,  $k = \frac{n}{n+m}$ , and is called the duty cycle, and  $V_s$  is the rms value of the input voltage.

- This type of control is used for applications (loads) with a high mechanical inertia or/and a high thermal time constant; e.g. industrial heating and speed control of motors.



- The output power for the resistive load is:

$$P_o = V_{Orms} I_{Orms} = \sqrt{k} V_s I_{Orms} = R I_{Orms}^2$$

where  $I_{Orms} = \frac{V_{Orms}}{R}$ , is the rms value of the output current and equals the input current!

- Assuming lossless controller, then the input power is:

$$P_{in} = P_o = \sqrt{k} V_s I_{Orms}$$

- The input apparent power is:

$$S_{in} = V_s I_{in} = V_s I_{Orms}$$

- Therefore, the input power Factor is:

$$PF = \frac{P_{in}}{S_{in}} = \frac{\sqrt{k} V_s I_{Orms}}{V_s I_{Orms}} = \sqrt{k} \quad (\text{lagging})$$

$$\Rightarrow PF = \sqrt{\frac{n}{n+m}} \quad (\text{lagging})$$

- The input power factor, as a function of the duty cycle, is depicted in the Figure below.

**Power Factor, PF**

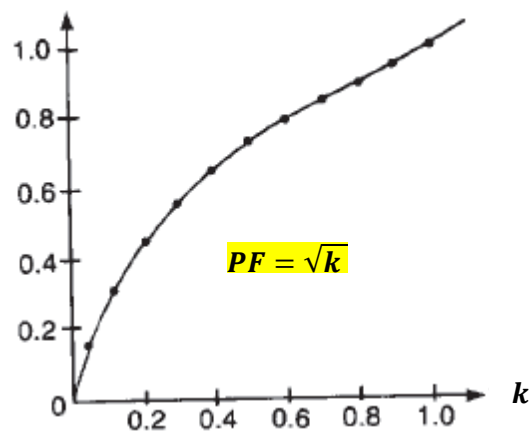

- Note that, the input power factor is very low at small duty cycles!

## II) Principle of Phase Angle Control

### II. 1) Single-Phase Half-Wave Controller

- It is also known as a Unidirectional Controller.
- The circuit topology of a Single-Phase Half-Wave Controller is shown in the Figure next.

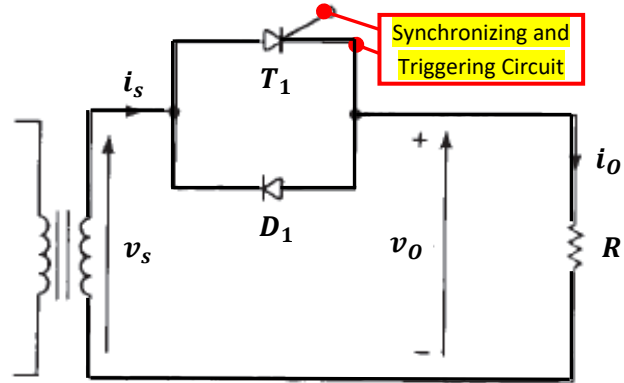

- The associated voltage and current waveforms of this controller are shown in the Figure next.

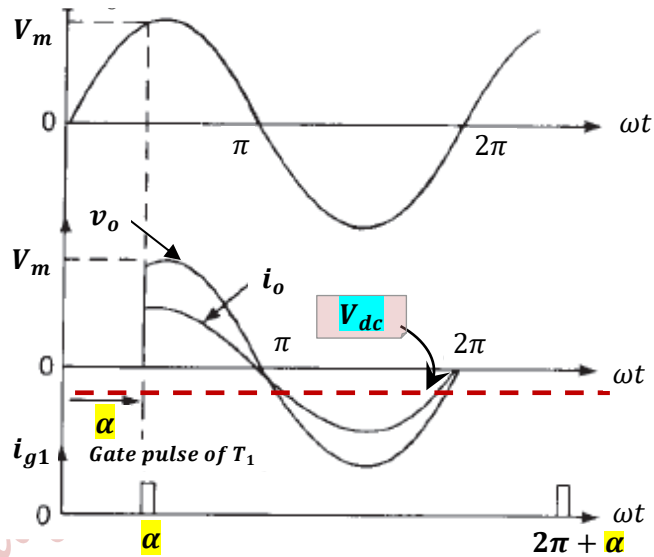

- The **root-mean-square** of the output voltage is:

$$V_{Orms} = \sqrt{\frac{1}{2\pi} \left( \int_{\alpha}^{\pi} (\sqrt{2}V_s \sin \omega t)^2 d\omega t + \int_{\pi}^{2\pi} (\sqrt{2}V_s \sin \omega t)^2 d\omega t \right)}$$

...

$$V_{Orms} = V_s \sqrt{\frac{1}{2\pi} \left( 2\pi - \alpha + \frac{\sin 2\alpha}{2} \right)}; \quad 0 < \alpha < \pi$$

- The **average output voltage** is:

$$V_{dc} = \frac{1}{2\pi} \left( \int_{\alpha}^{\pi} \sqrt{2}V_s \sin \omega t d\omega t + \int_{\pi}^{2\pi} \sqrt{2}V_s \sin \omega t d\omega t \right)$$

...

$$V_{dc} = \frac{\sqrt{2}V_s}{2\pi} (\cos \alpha - 1); \quad 0 < \alpha < \pi$$

Note that,  $V_{Orms}$  varies from  $V_s$  to  $0.707V_s$  by varying  $\alpha$  from 0 to  $\pi$ ,

whilst  $V_{dc}$  can be varied from 0V to  $-\frac{\sqrt{2}V_s}{\pi}$  by varying  $\alpha$  from 0 to  $\pi$ .

- The DC current may cause saturation problem to transformer core, hence **this method is rarely used**.

### Example 6-2

A single-phase ac voltage controller in Fig. 6-2a has a resistive load of  $R = 10 \Omega$  and the input voltage is  $V_s = 120 \text{ V}$ , 60 Hz. The delay angle of thyristor  $T_1$  is  $\alpha = \pi/2$ . Determine the (a) rms value of output voltage,  $V_o$ ; (b) input power factor, PF; and (c) average input current.

**Solution**  $R = 10 \Omega$ ,  $V_s = 120 \text{ V}$ ,  $\alpha = \pi/2$ , and  $V_m = \sqrt{2} \times 120 = 169.7 \text{ V}$ .

(a) From Eq. (6-5), the rms value of the output voltage,

$$V_o = 120 \sqrt{\frac{3}{4}} = 103.92 \text{ V}$$

(b) The rms load current,

$$I_o = \frac{V_o}{R} = \frac{103.92}{10} = 10.392 \text{ A}$$

The load power,

$$P_o = I_o^2 R = 10.392^2 \times 10 = 1079.94 \text{ W}$$

Since the input current is the same as the load current, the input volt-ampere rating is

$$\text{VA} = V_s I_s = V_s I_o = 120 \times 10.392 = 1247.04 \text{ VA}$$

The input power factor,

$$\begin{aligned} \text{PF} &= \frac{P_o}{\text{VA}} = \frac{V_o}{V_s} = \left[ \frac{1}{2\pi} \left( 2\pi - \alpha + \frac{\sin 2\alpha}{2} \right) \right]^{1/2} \\ &= \sqrt{\frac{3}{4}} = \frac{1079.94}{1247.04} = 0.866 \text{ (lagging)} \end{aligned} \quad (6-7)$$

(c) From Eq. (6-6), the average output voltage,

$$V_{dc} = -120 \times \frac{\sqrt{2}}{2\pi} = -27 \text{ V}$$

and the average input current,

$$I_D = \frac{V_{dc}}{R} = -\frac{27}{10} = -2.7 \text{ A}$$

*Note.* The negative sign of  $I_D$  signifies that the input current during the positive half-cycle is less than that during the negative half-cycle. If there is an input transformer, the transformer core may be saturated. The unidirectional control is not normally used in practice.

## II. 2) Single-Phase Full-Wave Controller

- ❖ It is known as a Bidirectional Controller
- ❖ The circuit topology of a Single-Phase Full-Wave Controller is shown in the Figure next.
- ❖  $T_1$  controls the power flow during the positive half-cycle, whilst  $T_2$  controls the power flow during the negative half-cycle.

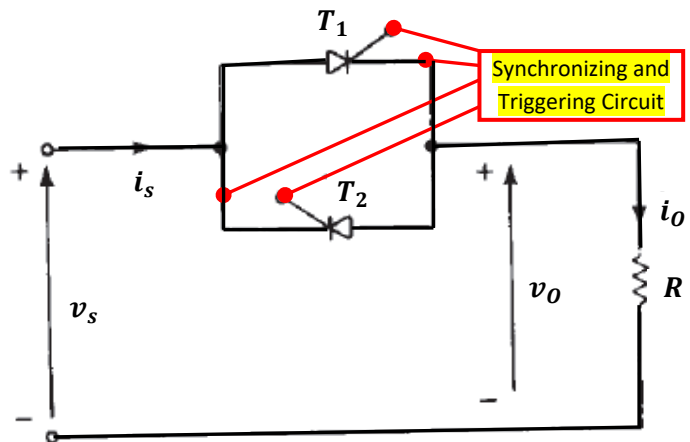

- ❖ The associated voltage and current waveforms of this controller are shown in the Figure below.

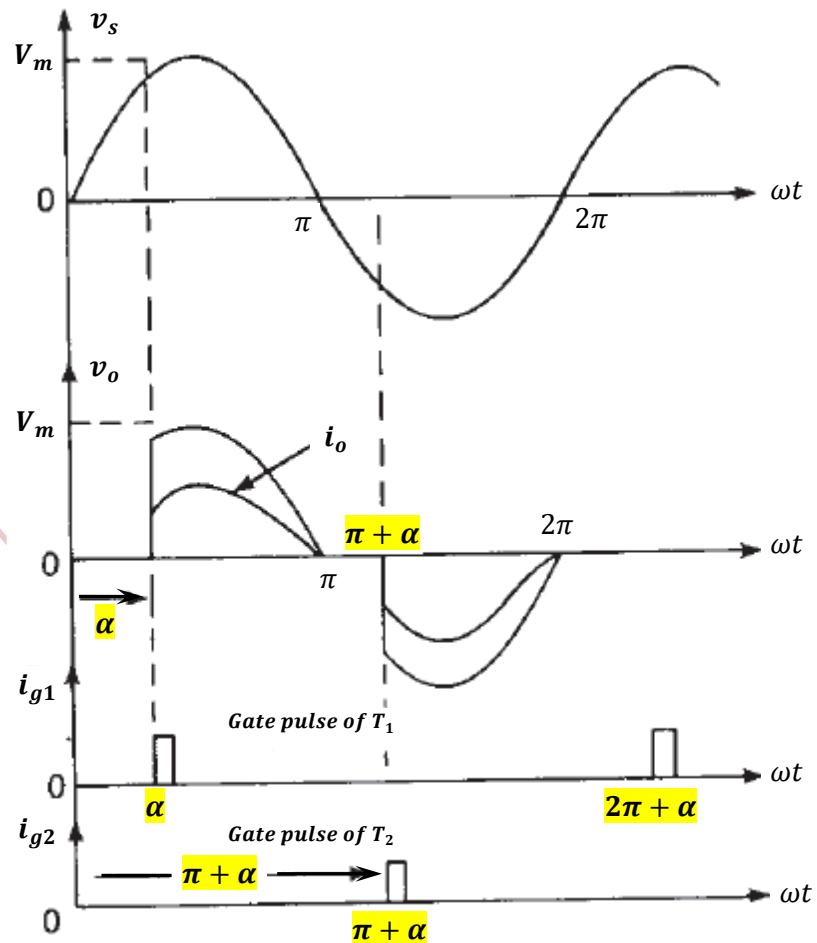

- ❖ The **root-mean-square** of the output voltage is:

$$V_{Orms} = \sqrt{\frac{2}{2\pi} \int_{\alpha}^{\pi} (\sqrt{2}V_s \sin \omega t)^2 d\omega t}$$

$$V_{Orms} = \sqrt{\frac{4V_s^2}{4\pi} \int_{\alpha}^{\pi} (1 - \cos 2\omega t) d\omega t}$$

....

$$V_{Orms} = V_s \sqrt{\frac{1}{\pi} \left( \pi - \alpha + \frac{\sin 2\alpha}{2} \right)}; \quad 0 < \alpha < \pi$$

Note that,  $V_{Orms}$  varies from  $V_s$  to 0 by varying  $\alpha$  from 0 to  $\pi$ ; a wider range of control!

- ❖ Because of the waveform symmetry in positive and half cycles, the **average output voltage** is zero. Therefore, there is no DC saturation problem to transformer core.
- ❖ Note that, the gate-circuits for  $T_1$  and  $T_2$  must be isolated; two isolations are required!
- ❖ By the connection in the Figure below, the Thyristors have a common cathode; only one isolation is required!

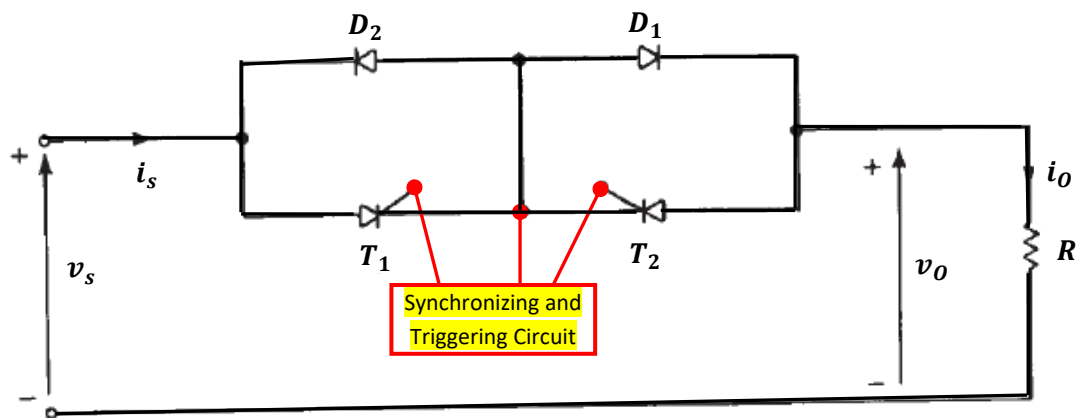

- ❖ However, the conduction losses are increased, as there are two conducting devices at the same time!

**Example 6-3**

A single-phase full-wave ac voltage controller in Fig. 6-3a has a resistive load of  $R = 10 \Omega$  and the input voltage is  $V_s = 120 \text{ V}$ , 60 Hz. The delay angles of thyristors  $T_1$  and  $T_2$  are equal:  $\alpha_1 = \alpha_2 = \alpha = \pi/2$ . Determine the (a) rms output voltage,  $V_o$ ; (b) input power factor, PF; (c) average current of thyristors,  $I_A$ ; and (d) rms current of thyristors,  $I_R$ .

**Solution**  $R = 10 \Omega$ ,  $V_s = 120 \text{ V}$ ,  $\alpha = \pi/2$ , and  $V_m = \sqrt{2} \times 120 = 169.7 \text{ V}$ .

(a) From Eq. (6-8), the rms output voltage,

$$V_o = \frac{120}{\sqrt{2}} = 84.85 \text{ V}$$

(b) The rms value of load current,  $I_o = V_o/R = 84.85/10 = 8.485 \text{ A}$  and the load power,  $P_o = I_o^2 R = 8.485^2 \times 10 = 719.95 \text{ W}$ . Since the input current is the same as the load current, the input volt-ampere rating,

$$\text{VA} = V_s I_s = V_s I_o = 120 \times 8.485 = 1018.2 \text{ W}$$

The input power factor,

$$\begin{aligned} \text{PF} &= \frac{P_o}{\text{VA}} = \frac{V_o}{V_s} = \left[ \frac{1}{\pi} \left( \pi - \alpha + \frac{\sin 2\alpha}{2} \right) \right]^{1/2} \\ &= \frac{1}{\sqrt{2}} = \frac{719.95}{1018.2} = 0.707 \text{ (lagging)} \end{aligned} \quad (6-9)$$

(c) The average thyristor current,

$$\begin{aligned} I_A &= \frac{1}{2\pi R} \int_{\alpha}^{\pi} \sqrt{2} V_s \sin \omega t \, d(\omega t) \\ &= \frac{\sqrt{2} V_s}{2\pi R} (\cos \alpha + 1) \\ &= \sqrt{2} \times \frac{120}{2\pi \times 10} = 2.7 \text{ A} \end{aligned} \quad (6-10)$$

(d) The rms value of the thyristor current,

$$\begin{aligned} I_R &= \left[ \frac{1}{2\pi R^2} \int_{\alpha}^{\pi} 2V_s^2 \sin^2 \omega t \, d(\omega t) \right]^{1/2} \\ &= \left[ \frac{2V_s^2}{4\pi R^2} \int_{\alpha}^{\pi} (1 - \cos 2\omega t) \, d(\omega t) \right]^{1/2} \\ &= \frac{V_s}{\sqrt{2} R} \left[ \frac{1}{\pi} \left( \pi - \alpha + \frac{\sin 2\alpha}{2} \right) \right]^{1/2} \\ &= \frac{120}{2 \times 10} = 6 \text{ A} \end{aligned} \quad (6-11)$$

## Three Phase Controllers

### A- Three-Phase Half-Wave (Unidirectional) Controllers

- The circuit topology for Unidirectional Three-Phase Controller is shown in the Figure below.

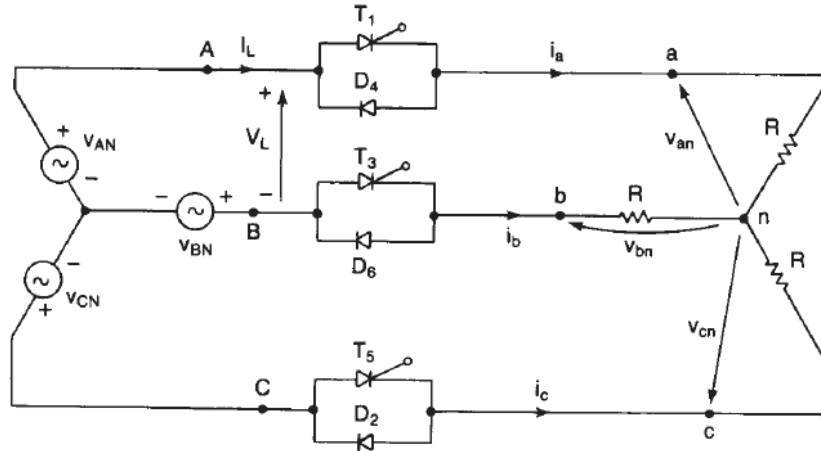

- At least one SCR must be conducting to allow the power flow to the load.
- The power flow to the load is controlled by  $T_1$ ,  $T_3$  and  $T_5$ . The diodes  $D_2$ ,  $D_4$  and  $D_6$  provide the return current path.
- Depending on the value of  $\alpha$  and voltage level, when two devices are conducting, the load phase voltage is  $\frac{V_L}{2}$ .
- Depending on the value of  $\alpha$  and the voltage level, when three devices are conducting; normal three phase voltages are applied to the load.
- Examples of the output voltage for different values of the firing angle are shown below.
- Due to the asymmetrical nature of the output voltage waveform, the **input current may contain a DC component**. Besides, the **harmonic content is high**, therefore this controller is **rarely used**.

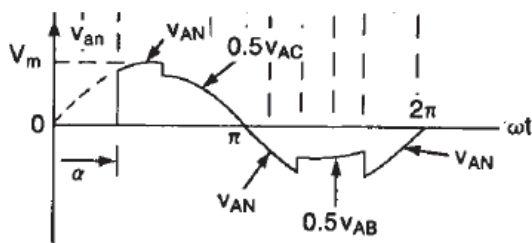
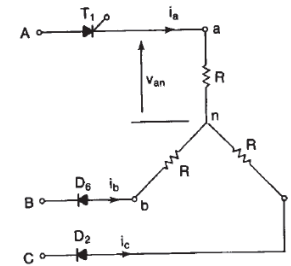
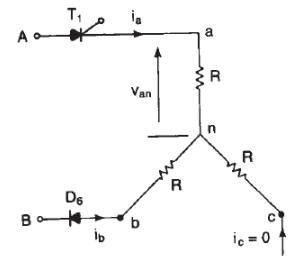

(a) For  $\alpha = 60^\circ$

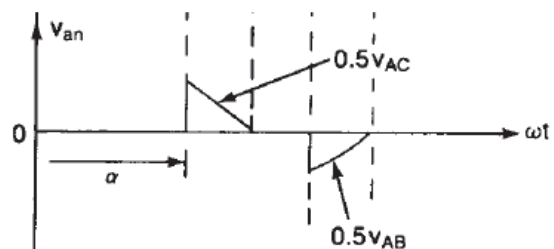

(b) For  $\alpha = 150^\circ$

## B- Three-Phase Full-Wave Controllers

- They are also known as Bidirectional Three-Phase Controllers.
- The circuit topology of the Full-Wave Controller is shown in the Figure below.
- The number of conducting Thyristors at any time depends on the value of the firing angle.

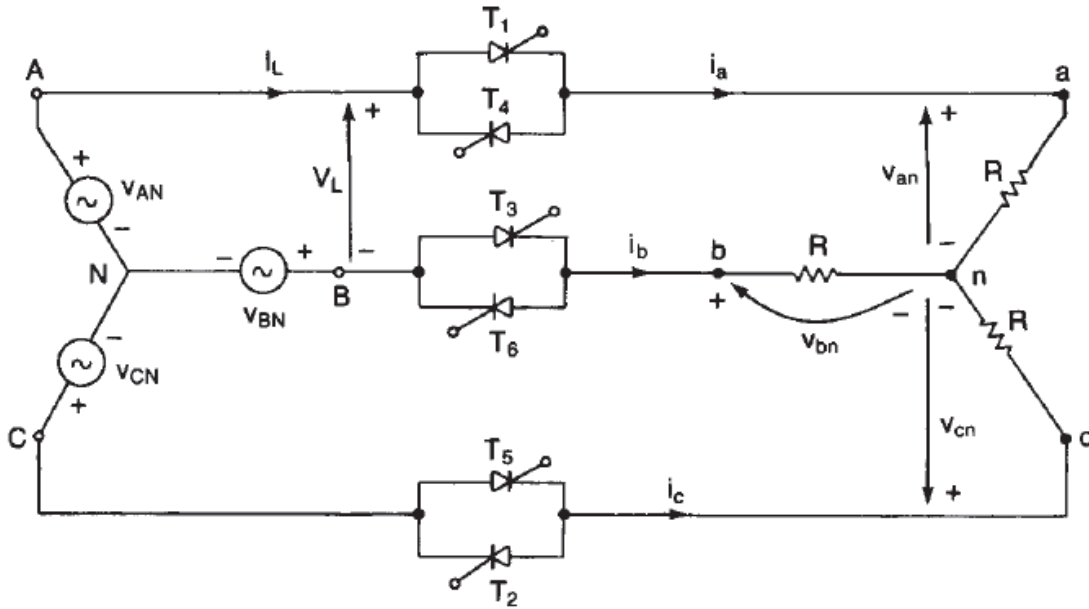

- Examples of the output voltage are shown in the Figure below.

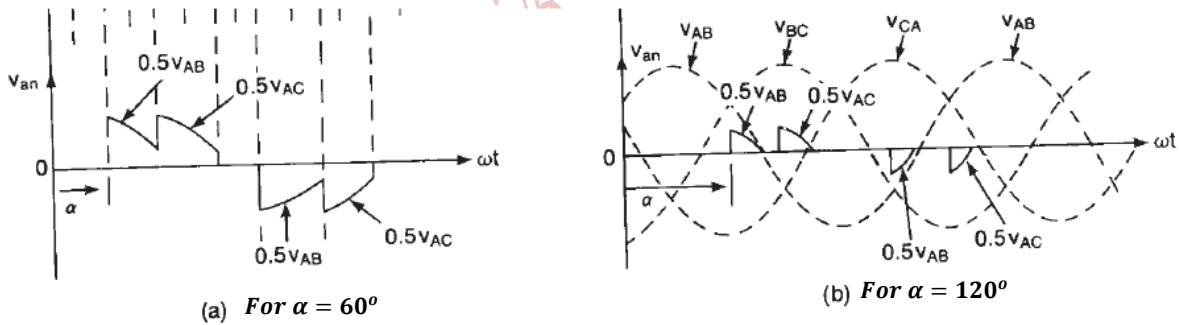

- Note that, the AC Voltage Controllers provide a **variable output voltage**, but the frequency **of the output is fixed**. In addition, the **harmonic content is high**, especially at low output voltage range.

**Exercise:** show modification on the above circuit to allow the controller to reverse the direction of rotation of an AC motor.



## Cycloconverters

- They convert AC power at a fixed voltage and frequency to AC power at a Variable Voltage and Variable Frequency (VVVF). The output frequency is usually fractions of the input frequency ( $\sim < \frac{1}{3}$  the source frequency).
- Thus, their major applications are low speed AC motor drives.
- Types of Cycloconverters:**

### 1) Single-Phase/Single-Phase Cycloconverters

- The circuit topology of a Single-Phase/Single-Phase Cycloconverter is shown in the Figure below.

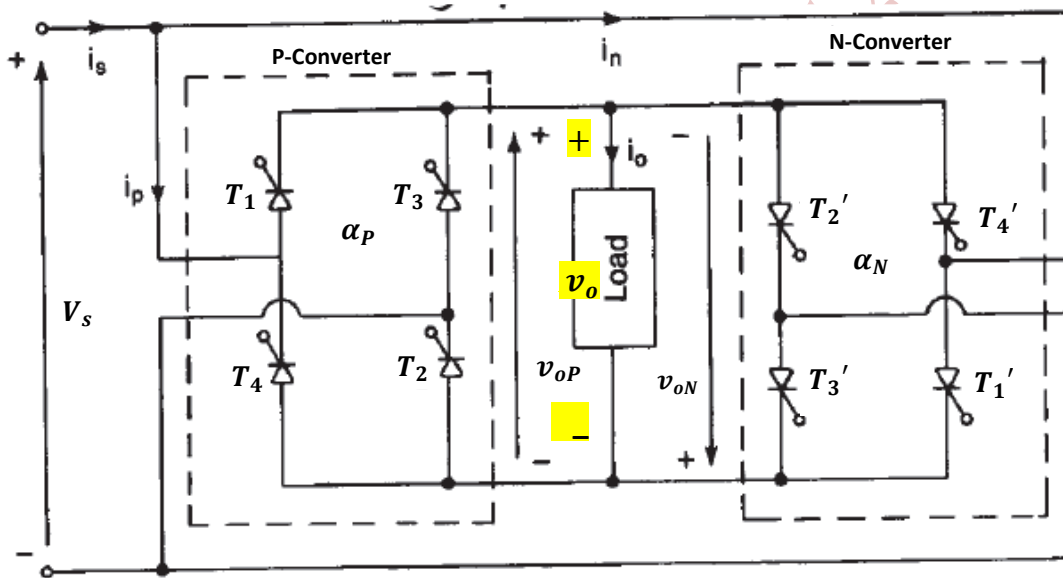

- Two Single-Phase Controlled Rectifiers (converters) are operated such that their average output voltages are equal and opposite to each other.
- If  $\alpha_P$  is the delay angle of Thyristors ( $T_1$  and  $T_2$ ) in the Positive Converter (P-Converter), and  $\alpha_N$  is the delay angle of Thyristors ( $T_1'$  and  $T_2'$ ) in the Negative Converter (N-Converter), then:  $\alpha_P = \alpha_N = \alpha$ , and  $V_{dcP} = |V_{dcN}|$ .

- ❖ The associated waveforms (for one period of the output voltage) of this type of Cycloconverter, supplying a resistive load, are shown in the Figure below.

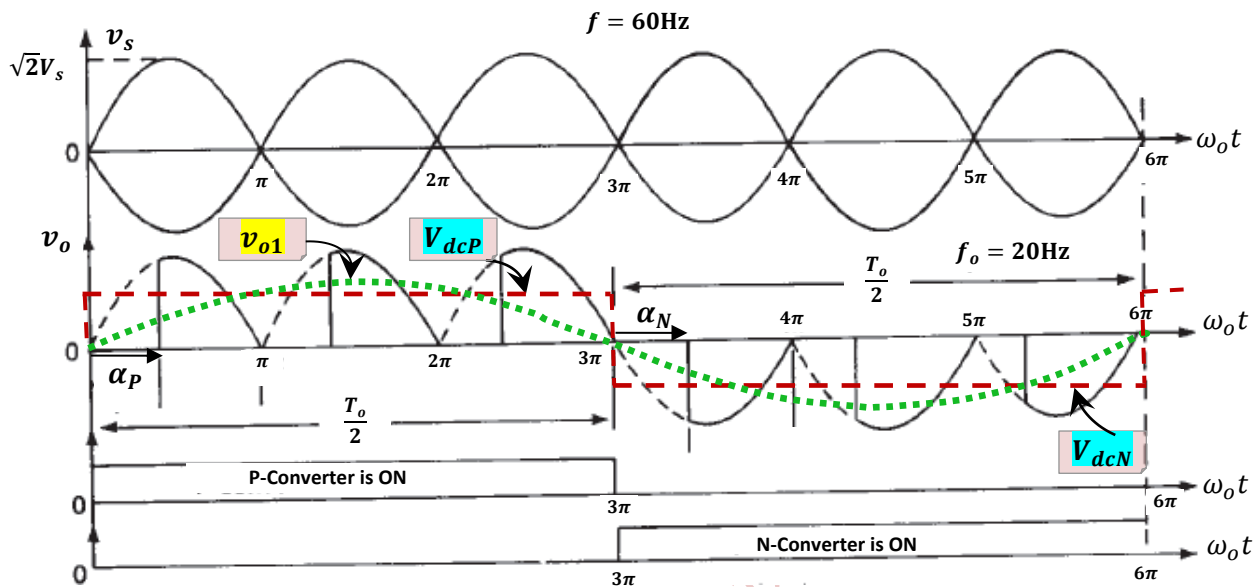

- ◆ For a resistive load, the average output voltage of the P-Converter is:

$$V_{dcP} = \frac{V_m}{\pi} (1 + \cos \alpha_P)$$

where,  $V_m$  is the peak phase voltage.

- ◆ For a resistive load, the average output voltage of the N-Converter is:

$$V_{dcN} = \frac{V_m}{\pi} (1 + \cos \alpha_N)$$

- ◆ The combined outputs of the two converters produce an effective square wave across the load, whose DC level is  $\frac{V_m}{\pi} (1 + \cos \alpha)$ ;
- ◆ The fundamental component of the output has a peak value of:

$$\hat{V}_{o1} = \frac{4}{\pi} \left( \frac{V_m}{\pi} (1 + \cos \alpha) \right); \quad 0 < \alpha < \pi$$

- ◆ The output voltage is:

$$v_o(t) = \hat{V}_{o1} \sin \omega_o t + \text{Harmonics}$$

- ◆ If the load is highly inductive, then the DC level of any converter is  $\frac{2V_m}{\pi} \cos \alpha$ , and the fundamental component of the output has a peak value of:

$$\hat{V}_{o1} = \frac{4}{\pi} \left( \frac{2V_m}{\pi} \cos \alpha \right)$$

- ◆ If a low pass filter was connected at the output, then the load will have only the fundamental component applied across it!
- ◆ It is obvious that, in either case of load type, the peak value of the fundamental component at the output voltage (and hence its rms value) can be varied by varying the firing angle of each converter, bearing in mind that  $\alpha_P = \alpha_N = \alpha$  (always!)
- ◆ The frequency of the fundamental component of the output voltage is:  $f_o = \frac{1}{T_o}$ , and can be controlled by adjusting the control voltage of each converter;  $(f_o = \frac{T}{T_o} f)$ . In this case,

$$f_o = \frac{2\pi}{6\pi} 60 = 20\text{Hz!}$$

- ◆ Note that, this type of controller has a Variable Voltage (controlled by the delay angles) and a Variable Frequency (controlled by the period during which each converter is operated) at its output. Hence, **VVVF Drive!**

## 2) Three-Phase/Single-Phase Cycloconverters

- ◆ The circuit topology of a Three-Phase/Single-Phase Cycloconverter is shown in the Figure below.

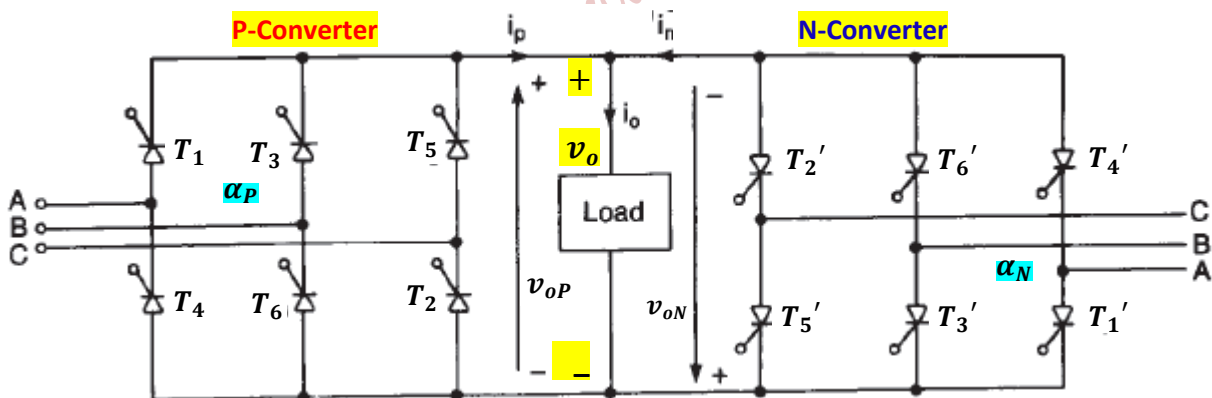

- ◆ It is used in higher power applications!
- ◆ Two Three-Phase Controlled Rectifiers (converters) are operated such that their average output voltages are equal and opposite to each other.
- ◆ If  $\alpha_P$  is the delay angle of Thyristor ( $T_1$ ) in the Positive Converter (P-Converter), and  $\alpha_N$  is the delay angle of Thyristor ( $T_1'$ ) in the Negative Converter (N-Converter), then:  $\alpha_P = \alpha_N = \alpha$ , and  $V_{dcP} = |V_{dcN}|$ .

- The associated voltage waveforms of a Three Phase/Single Phase Cycloconverter for one period of the output voltage are shown in the Figure below. The waveforms are for illustration and are not exact; as there should be 30 pulses in 5 cycles of the input voltage.

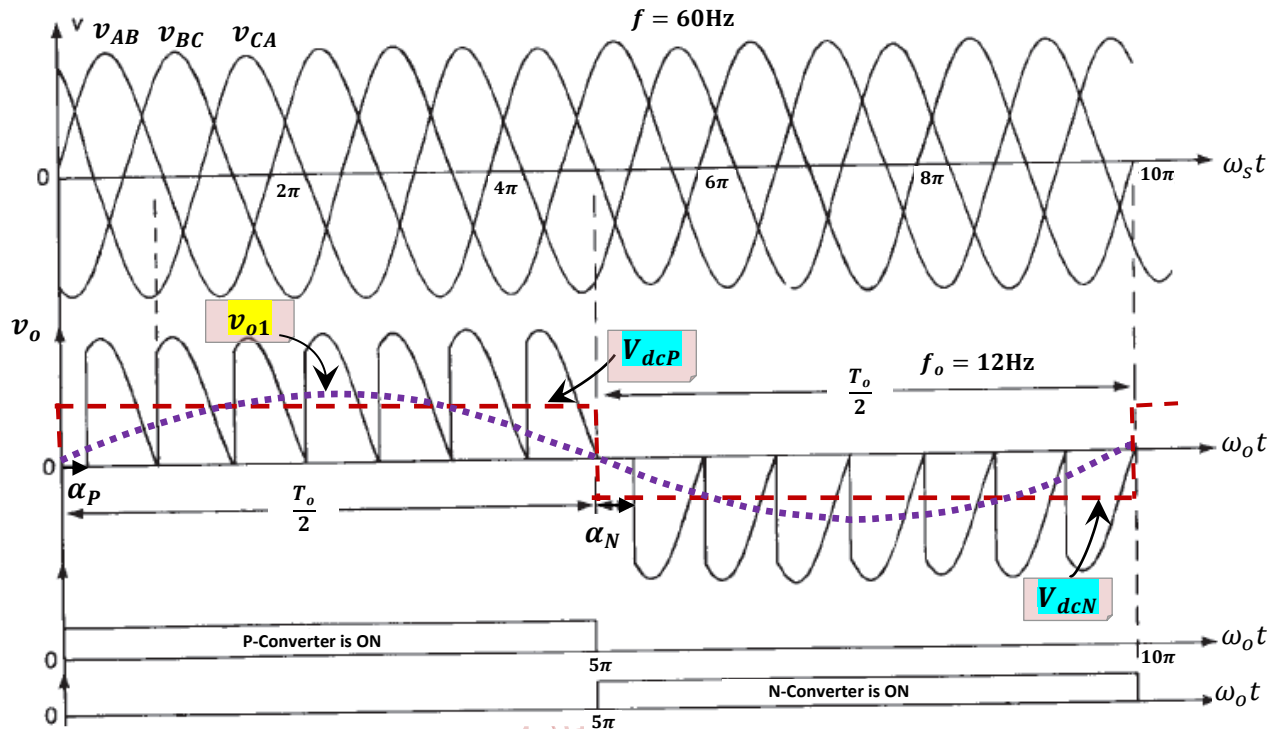

- Similar to Single Phase/Single Phase Cycloconverter, for a resistive load, the average output voltage of the P-Converter is:

$$V_{dcP} = \begin{cases} \frac{3\sqrt{3}V_m}{\pi} \cos \alpha; & \alpha \leq \frac{\pi}{3} \\ \frac{3\sqrt{3}V_m}{\pi} \left(1 + \cos\left(\alpha + \frac{\pi}{3}\right)\right); & \frac{\pi}{3} < \alpha < \frac{4\pi}{6} \end{cases}$$

where,  $V_m$  is the peak phase voltage.

- For a resistive load, the average output voltage of the N-Converter is:

$$V_{dcN} = \begin{cases} \frac{3\sqrt{3}V_m}{\pi} \cos \alpha; & \alpha \leq \frac{\pi}{3} \\ \frac{3\sqrt{3}V_m}{\pi} \left(1 + \cos\left(\alpha + \frac{\pi}{3}\right)\right); & \frac{\pi}{3} < \alpha < \frac{4\pi}{6} \end{cases}$$

- The combined outputs of the two converters produce an effective square wave across the load,

whose DC level is,  $V_{dc} = \begin{cases} \frac{3\sqrt{3}V_m}{\pi} \cos \alpha; & \alpha \leq \frac{\pi}{3} \\ \frac{3\sqrt{3}V_m}{\pi} \left(1 + \cos\left(\alpha + \frac{\pi}{3}\right)\right); & \frac{\pi}{3} < \alpha < \frac{4\pi}{6} \end{cases}$

- ◆ The fundamental component of the output has a peak value of:

$$\hat{V}_{o1} = \frac{4}{\pi} (V_{dc})$$

$$\hat{V}_{o1} = \frac{4}{\pi} \begin{cases} \frac{3\sqrt{3}V_m}{\pi} \cos \alpha; & \alpha \leq \frac{\pi}{3} \\ \frac{3\sqrt{3}V_m}{\pi} \left(1 + \cos\left(\alpha + \frac{\pi}{3}\right)\right); & \frac{\pi}{3} < \alpha < \frac{4\pi}{6} \end{cases}$$

- ◆ If the load is highly inductive, then the DC level of any converter is  $\frac{3\sqrt{3}V_m}{\pi} \cos \alpha$ , and the fundamental component of the output has a peak value of:

$$\hat{V}_{o1} = \frac{4}{\pi} \left( \frac{3\sqrt{3}V_m}{\pi} \cos \alpha \right); \quad 0 \leq \alpha < \pi$$

- ◆ If a low pass filter was used at the output, then the load will have only the fundamental component applied across it!
- ◆ It is obvious that, in either case of load, the peak value of the fundamental component at the output voltage (and hence its rms value) can be varied by varying the firing angle of each converter, bearing in mind that  $\alpha_P = \alpha_N = \alpha$ . (always!)
- ◆ The frequency of the fundamental component of the output voltage is:  $f_o = \frac{1}{T_o}$ , and can be controlled by adjusting the control voltage of each converter;  $\left(f_o = \frac{T}{T_o} f\right)$ . In this case,

$$f_o = \frac{2\pi}{10\pi} 60 = 12\text{Hz!}$$

- ◆ Note that, this type of controller has a Variable Voltage (controlled by the delay angles) and a Variable Frequency (controlled by the period during which each converter is operated) at its output. Hence, a **VVVF Drive** results!

### 3) Three-Phase/Three-Phase Cycloconverters

#### a) Full-Wave Three-Phase/Three-Phase Cycloconverter

- ➔ If '3' Three-Phase/Single-Phase Cycloconverters are used (with appropriate control voltages applied to each converter), then a Full-Wave Three-Phase/Three-Phase Cycloconverter results. The loads in this case have to be connected as WYE or Delta.
- ➔ The controlled voltages of the converters have to be shifted by  $120^\circ$  for each phase!
- ➔ In this type of converter 36 SCRs are needed!

#### b) Half-Wave Three-Phase/Three-Phase Cycloconverter

- The circuit topology of such a Cycloconverter is shown in the Figure below.
- In this type of converter only 18 SCRs are needed!

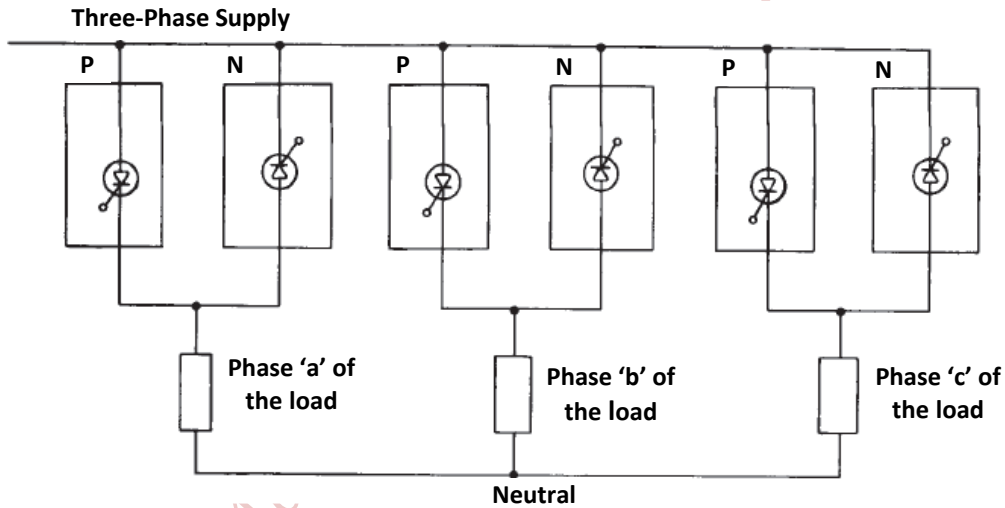

- Each phase of the output can be connected to the three inputs, as shown in the Figure below.

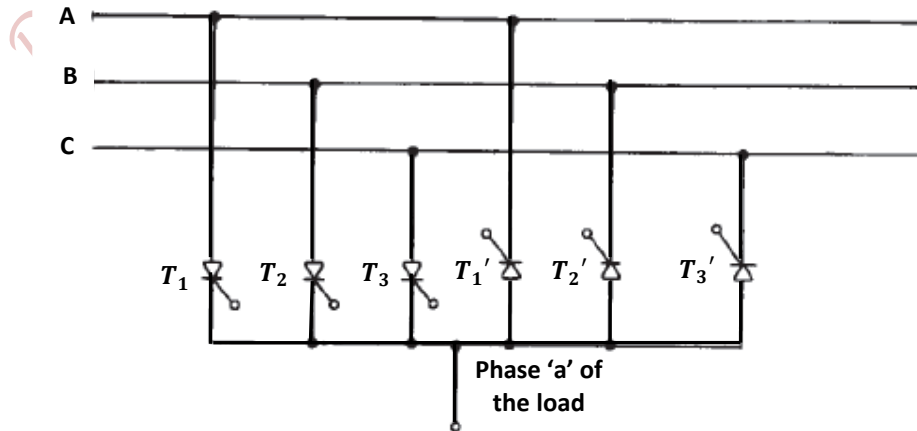

## Matrix Converters

- A Matrix converter is fairly a new converter topology, which was first proposed in the beginning of the 1980's. It is a newer form of the Cycloconverter!
- A Matrix Converter consists of **nine bidirectional switches** connecting any of the three input voltages to any of the three output phases directly as shown in the Figure below. The inputs are of voltage source characteristics and the outputs are of current source characteristics (because most loads are of an inductive nature).

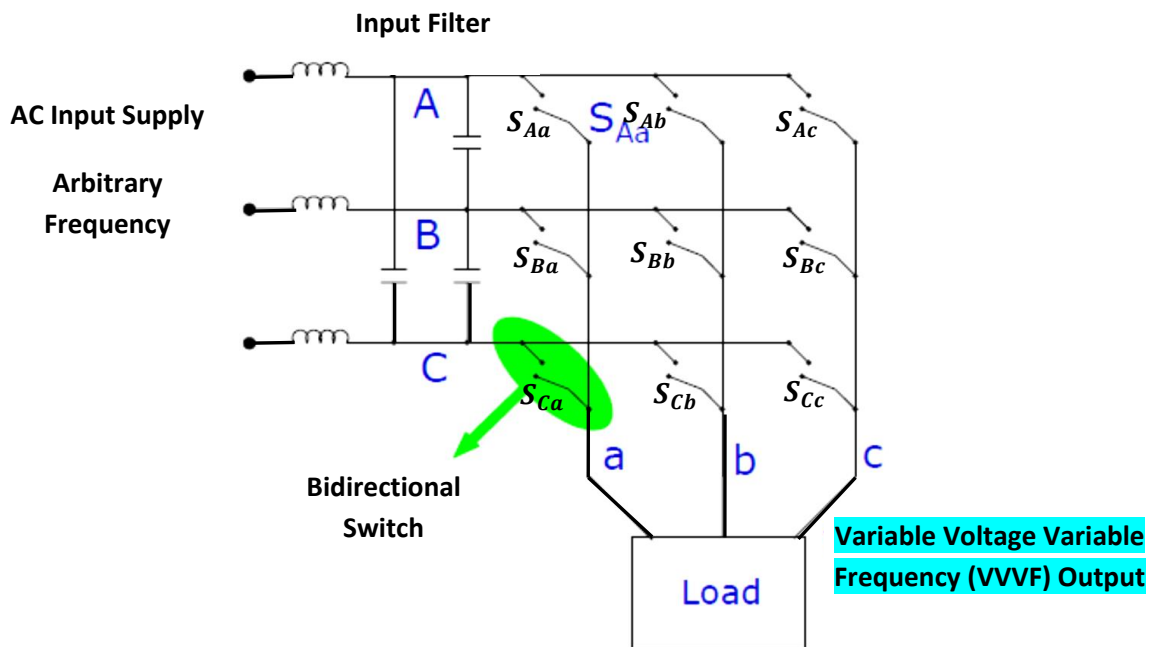

- The switches in the Matrix Converter are bidirectional switches; that is, they must be able to support a voltage of either polarity, and be able to conduct a current in either direction.
- An example of a bidirectional switch constructed from non-reverse blocking IGBTs and diodes is shown in the Figure next.
- If reverse blocking IGBTs are available, then the bidirectional switch will be as shown in the Figure next.

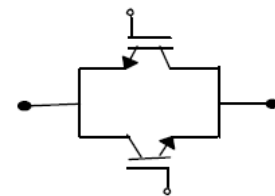
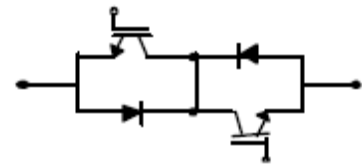

- Any input phase can be connected to any output phase at any time, depending on the control. The output depends on the state of switches;

$$\begin{bmatrix} V_{an} \\ V_{bn} \\ V_{cn} \end{bmatrix} = \begin{bmatrix} S_{Aa} & S_{Ba} & S_{Ca} \\ S_{Ab} & S_{Bb} & S_{Cb} \\ S_{Ac} & S_{Bc} & S_{Cc} \end{bmatrix} \begin{bmatrix} V_{AN} \\ V_{BN} \\ V_{CN} \end{bmatrix}$$

where,  $V_{an}$ ,  $V_{bn}$  and  $V_{cn}$ , are the output phase – load neutral voltages!

- However, no two switches from the same phase can be connected at the same time, such that to avoid applying a short circuit across the input phases. This makes the current commutation and switches control very complex in such a converter.
- These converters are controlled by Pulse Width Modulation (PWM) techniques to produce a Variable Voltage Variable Frequency (VVVF) three-phase output (even for output frequencies higher than the input frequency).
- An example of an output voltage waveform at 25Hz (obtained from 50Hz sources) is shown in the Figure below.

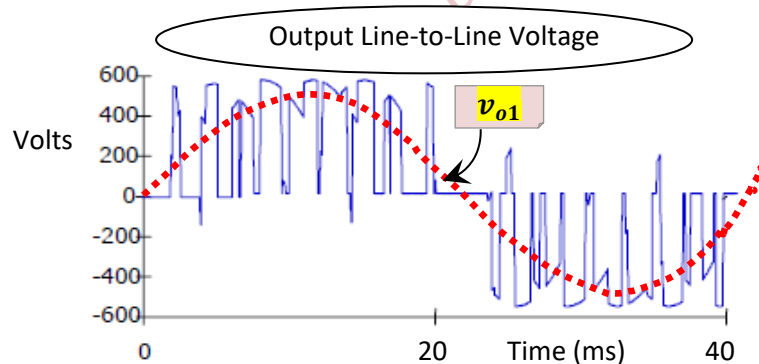

- The outputs of these converters have lower harmonic content compared to those in the outputs of Cycloconverters, as clearly seen in the frequency spectrum of the Figure below, at which the switching frequency  $f_s = 2\text{kHz}$ . Here, the switching frequency is reduced deliberately for illustration purposes!

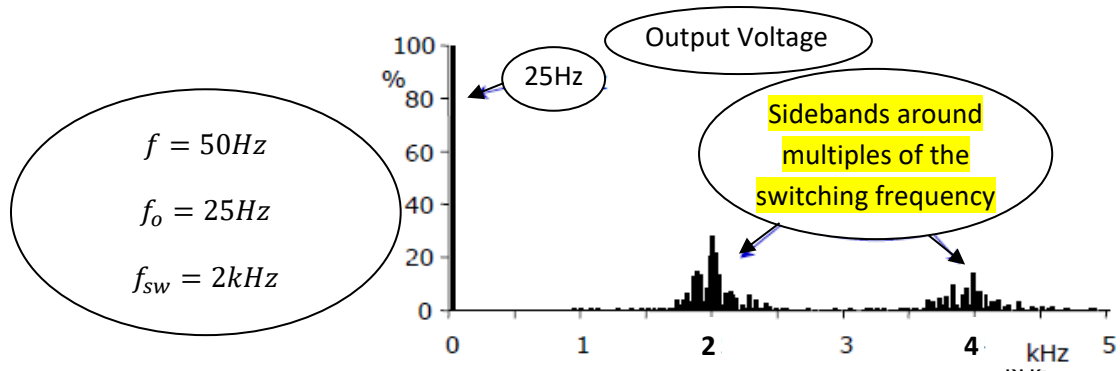



---

# Part V: DC Choppers (DC-to-DC Converters)

---

- ▶ They are also called DC-to-DC Switch Mode converters!
- ▶ They are often used in switch mode DC power supplies and in DC motor Drives.
- ▶ They are the basis for non-linear voltage regulators; more efficient regulators!

A typical Block Diagram of a DC-to-DC Converter system is as follows:

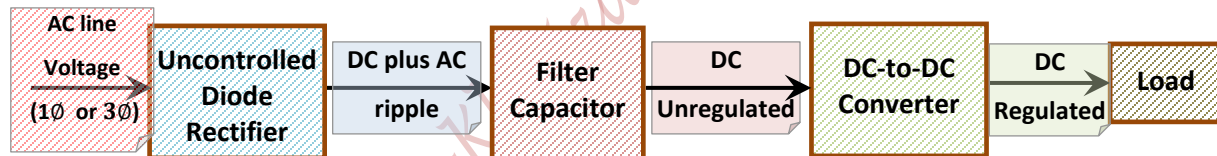

**Main Types of DC-to-DC Converters (Choppers):**

- 3) Step-down (Buck) Converter
- 4) Step-up (Boost) Converter
- 5) Step-down/Step-up (Buck-Boost) Converter
- 6) Full Bridge DC-to-DC Converter

## 1) Principle of Step-down (Buck) Operation

The basic topology of Step-down (Buck) converter is shown in the Figure next.

The switch could be any type of controllable switches; a Power BJT, a Power MOSFET, an IGBT, a GTO, an IGCT, or even an SCR with its commutation circuit, etc...

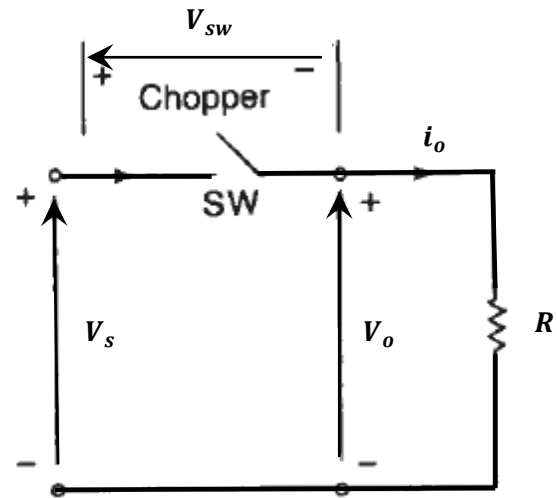

The switch is turned 'on' for a specific time ( $t_{on}$ ), and is turned 'off' for another specific time ( $t_{off}$ ), as depicted by the waveforms  $V_{control}$  in the Figure next.

The average output voltage is:

$$V_{av} = \frac{1}{T_s} \int_0^{t_{on}} v_o dt$$

$$V_{av} = \frac{1}{T_s} \int_0^{t_{on}} V_s dt = \frac{t_{on}}{T_s} V_s$$

$$V_{av} = t_{on} f_s V_s$$

$$V_{av} = k V_s; \quad 0 \leq k \leq 1$$

and the average current is:

$$I_{av} = \frac{k V_s}{R}$$

where,  $T_s$  is the chopping period,

$k = \frac{t_{on}}{T_s}$  is the duty cycle of the

chopper,  $f_s$  is the chopping

(switching) frequency, and varies between a few kHz to a few hundred kHz.

$k$  varies between '0' and '1'. Therefore,  $V_{av}$  varies between '0' to ' $V_s$ '.

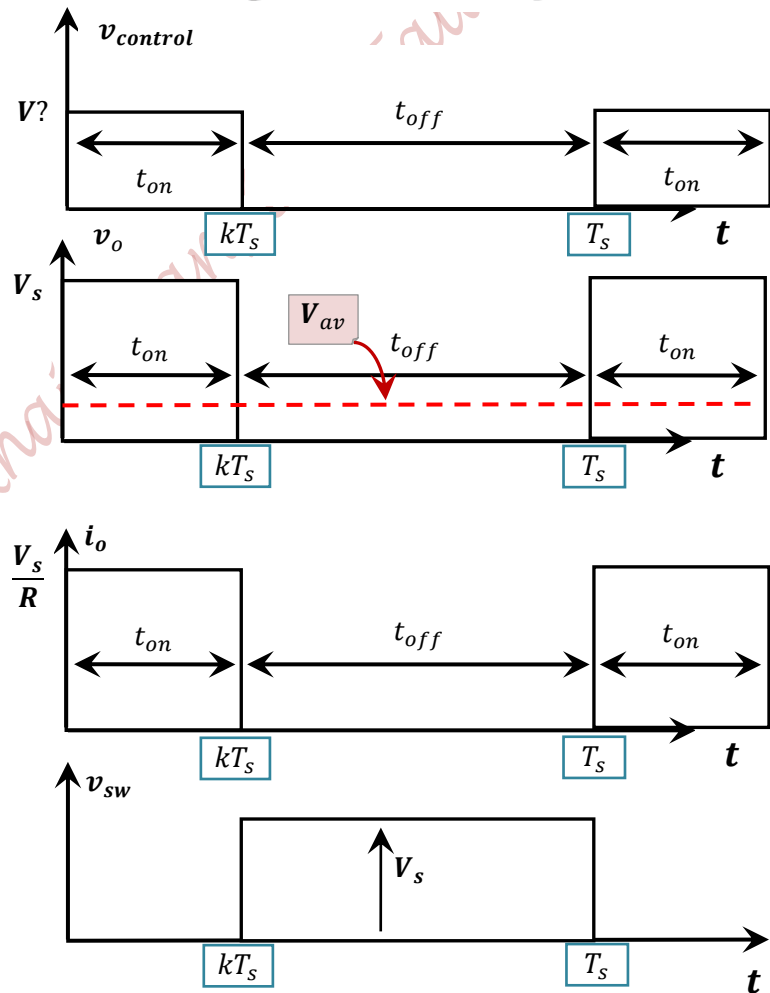

- The rms value of the output voltage is:

$$V_{Orms} = \sqrt{\frac{1}{T_s} \int_0^{kT_s} (v_o)^2 dt}$$

...

$$V_{Orms} = \sqrt{k}V_s; \quad 0 \leq k \leq 1$$

- Assuming a lossless chopper, **the input power** to the chopper is the same as the output power (power in DC and AC components) and is given by:

$$P_{in} = P_o = \frac{1}{T_s} \int_0^{t_{on}} i_o v_o dt$$

$$P_{in} = P_o = \frac{1}{T_s} \int_0^{kT_s} \frac{(v_o)^2}{R} dt$$

$$P_{in} = P_o = k \frac{(V_s)^2}{R}$$

- The effective **input resistance** (seen by the source) is:

$$R_{in} = \frac{V_s}{I_{av}} = \frac{V_s}{\frac{kV_s}{R}}$$

$$R_{in} = \frac{R}{k}$$

Note that, the chopper and the load are seen by the source as a variable resistor dependent on  $k$ !

- The duty cycle,  $k$ , can be varied from '0' to '1' by varying either  $t_{on}$ ,  $t_{off}$ , or  $T_s$  and  $f_s$ .

## Duty Cycle Control

### A) Constant Frequency Operation

In this type of control,  $T_s$  is kept constant, whilst  $t_{on}$  (and  $t_{off}$ ) is varied. This method is called **P**ulse **W**idth **M**odulation (PWM) control. It is a more commonly used method.

PWM can be achieved by comparing a sawtooth (or a triangular) voltage with a control (constant) voltage, as shown in the Figure on the next page.

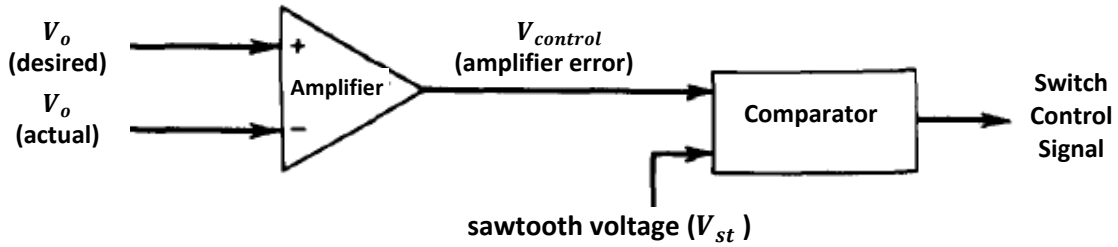

The resulting waveforms are shown in the Figure next.

Note, from symmetrical triangles:

$$\frac{kT_s}{T_s} = \frac{V_{control}}{\hat{V}_{st}} \Rightarrow k = \frac{V_{control}}{\hat{V}_{st}}$$

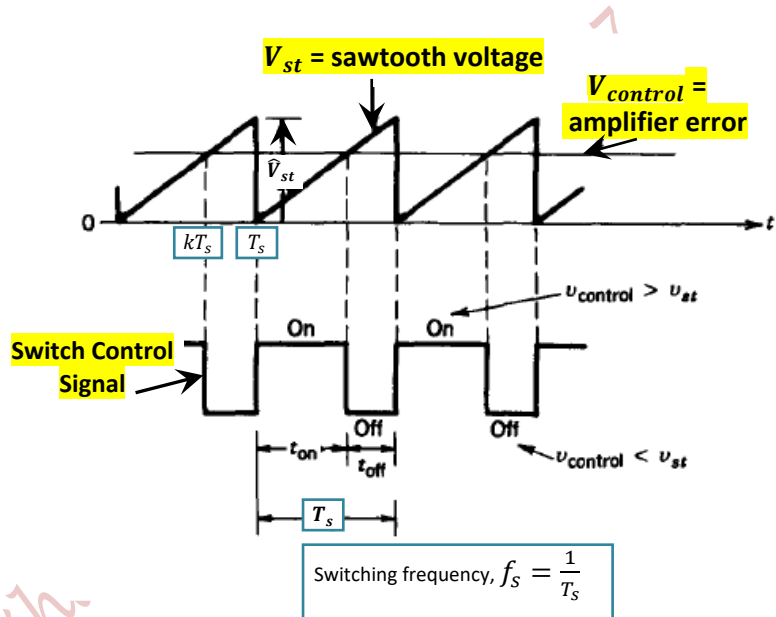

## B) Variable Frequency Operation

The switching frequency ( $f_s$ ) is varied; either  $t_{on}$  or  $t_{off}$  is kept constant. This method is called frequency modulation. This type of control would generate the significant harmonic at an unpredictable (a variable) frequency, and the output filter design would be difficult. Therefore, it is rarely used!

### Example 7-1

The dc chopper in Fig. 7-1a has a resistive load of  $R = 10 \Omega$  and the input voltage is  $V_s = 220 \text{ V}$ . When the chopper switch remains on, its voltage drop is  $v_{\text{ch}} = 2 \text{ V}$  and the chopping frequency is  $f = 1 \text{ kHz}$ . If the duty cycle is 50%, determine the (a) average output voltage,  $V_a$ ; (b) rms output voltage,  $V_o$ ; (c) chopper efficiency; (d) effective input resistance of the chopper,  $R_i$ ;

**Solution**  $V_s = 220 \text{ V}$ ,  $k = 0.5$ ,  $R = 10 \Omega$ , and  $v_{\text{ch}} = 2 \text{ V}$ .

(a) From Eq. (7-1),  $V_a = 0.5 \times (220 - 2) = 109 \text{ V}$ .

(b) From Eq. (7-2),  $V_o = \sqrt{0.5} \times (220 - 2) = 154.15 \text{ V}$ .

(c) The output power can be found from

$$\begin{aligned} P_o &= \frac{1}{T} \int_0^{kT} \frac{v_o^2}{R} dt = \frac{1}{T} \int_0^{kT} \frac{(V_s - v_{\text{ch}})^2}{R} dt = k \frac{(V_s - v_{\text{ch}})^2}{R} \\ &= 0.5 \times \frac{(220 - 2)^2}{10} = 2376.2 \text{ W} \end{aligned} \quad (7-5)$$

The input power to the chopper can be found from

$$\begin{aligned} P_i &= \frac{1}{T} \int_0^{kT} V_s i dt = \frac{1}{T} \int_0^{kT} \frac{V_s (V_s - v_{\text{ch}})}{R} dt = k \frac{V_s (V_s - v_{\text{ch}})}{R} \\ &= 0.5 \times 220 \times \frac{220 - 2}{10} = 2398 \text{ W} \end{aligned} \quad (7-6)$$

The chopper efficiency is

$$\frac{P_o}{P_i} = \frac{2376.2}{2398} = 99.09\%$$

(d) From Eq. (7-4),  $R_i = 10/0.5 = 20 \Omega$ .

Dr. M.

## Step-down Chopper with an 'RL' Load

➤ Consider the circuit shown in the Figure next.

➤ 'E' could represent the back emf of a DC motor!

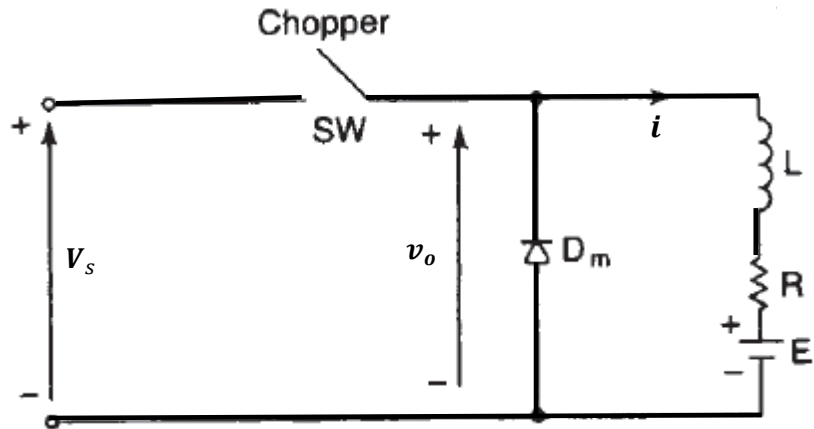

➤ There are two modes of operation, as shown in the Figures below.

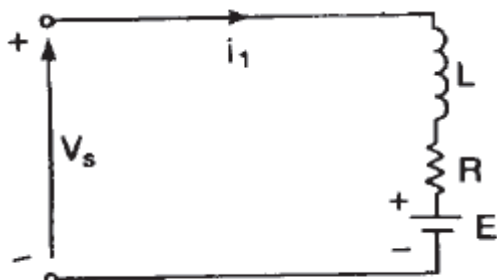

Mode 1

(The switch is closed)  
(The diode is off)

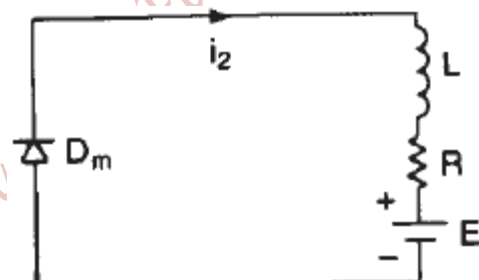

Mode 2

(The switch is opened)  
(The diode is on)

The inductor charges during mode '1' and its current rises, whilst the inductor discharges during mode '2' and its current falls. The Figure next shows the waveforms assuming **continuous current conduction**.

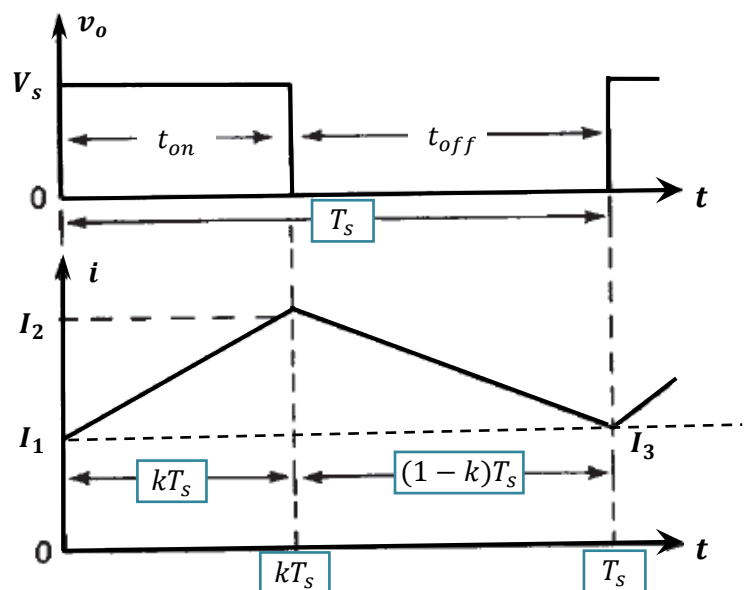

**For Mode 1 ( $0 \leq t \leq kT_s$ ),** applying KVL for the equivalent circuit yields,

$$V_s = i_1 R + L \frac{di_1(t)}{dt} + E$$

If  $i_1(t = 0) = I_1$ , then:

$$i_1(t) = i_1(\infty) + (i_1(0^+) - i_1(\infty))e^{-\frac{t}{\tau}}$$

where,  $\tau = \frac{L}{R}$  is the load time constant.

$$i_1(t) = \frac{V_s - E}{R} + \left( I_1 - \frac{V_s - E}{R} \right) e^{-\frac{Rt}{L}}; \quad 0 \leq t \leq kT_s$$

At the end of Mode 1,  $t = kT_s$ , the current is:

$$i_1(t = kT_s) = I_2 = \frac{V_s - E}{R} + \left( I_1 - \frac{V_s - E}{R} \right) e^{-\frac{RkT_s}{L}}$$

**For Mode 2 ( $kT_s \leq t \leq T_s$ ),** applying KVL for the equivalent circuit yields,

$$0 = i_2 R + L \frac{di_2(t)}{dt} + E$$

- But, the initial condition for the current is,  $i_2(t' = 0) = I_2$ ; redefining the time origin such that  $t' = 0$  at the beginning of Mode '2'.
- Therefore,

$$i_2(t') = \frac{-E}{R} + \left( I_2 + \frac{E}{R} \right) e^{-\frac{Rt'}{L}}; \quad 0 \leq t' \leq (1 - k)T_s$$

- Assuming a continuous current, at the end of Mode '2',  $t' = (1 - k)T_s$  and  $i_2(t' = (1 - k)T_s) = I_3$ .

$$I_3 = \frac{-E}{R} + \left( I_2 + \frac{E}{R} \right) e^{-\frac{R(1-k)T_s}{L}}$$

- Under steady state conditions,  $I_3 = I_1$ ; i.e.,

$$I_1 = I_3 = \frac{-E}{R} + \left( I_2 + \frac{E}{R} \right) e^{-\frac{R(1-k)T_s}{L}}$$

- The peak-to-peak current ripple is defined as:

$$\Delta I = I_2 - I_1$$

- A formula for the peak-to-peak current ripple can be obtained by simplifying the (“ $I_1$ ”) equation,

$$\Delta I = \frac{V_s}{R} \frac{1 - e^{-\frac{RkT_s}{L}} + e^{-\frac{RT_s}{L}} - e^{-\frac{R(1-k)T_s}{L}}}{1 - e^{-\frac{RT_s}{L}}}$$

- A detailed derivation for the above formula is illustrated next page.
- This peak-to-peak current ripple causes torque pulsation and vibrations in DC motors.

- Note that, the peak-to-peak current ripple is a function of the duty cycle,  $k$ .
- The value of the duty cycle  $k$  at the maximum peak-to-peak current ripple can be obtained by deriving

$\Delta I$  with respect to  $k$  and equating with zero;  $\frac{d(\Delta I)}{dk} = 0$ ;

$$e^{-\frac{RkT_s}{L}} - e^{-\frac{R(1-k)T_s}{L}} = 0$$

$$\Rightarrow -k = -(1 - k) \text{ or } \mathbf{k = 0.5}$$

Thus, the maximum peak-to-peak current ripple occurs at  $\mathbf{k = 0.5!!}$

- Therefore, the maximum peak-to-peak current ripple at  $k = 0.5$  is:

$$\Delta I_{max} = \frac{V_s}{R} \tanh \frac{R}{4f_s L}$$

Note that,  $\tanh x = \frac{\sinh x}{\cosh x} = \frac{e^x - e^{-x}}{e^x + e^{-x}}$

- For a large load time constant,  $\frac{L}{R} \gg T_s$  (i. e.,  $4f_s L \gg R$ ), the approximation  $\tanh x \cong x$  can be used;

$$\therefore \Delta I_{max} \cong \frac{V_s}{4f_s L}$$

- The above derived equations are valid for a continuous output current (when  $\frac{L}{R} \gg T_s$ ).



Proof of  $\Delta I$  Equation for a Continuous Inductor Current

$$\begin{aligned}
 \Delta I &= I_2 - I_1 \\
 &= I_1 e^{-\frac{KT}{L}} + \frac{V_S - E}{R} \left(1 - e^{-\frac{KT}{L}}\right) - I_2 e^{-\frac{(1-K)TR}{L}} \\
 &\quad + \frac{E}{R} \left(1 - e^{-\frac{(1-K)TR}{L}}\right) \\
 &= e^{-\frac{KT}{L}} \left( I_2 e^{-\frac{(1-K)TR}{L}} - \frac{E}{R} \left(1 - e^{-\frac{(1-K)TR}{L}}\right) \right) + \frac{V_S - E}{R} \left(1 - e^{-\frac{KT}{L}}\right) \\
 &\quad - I_2 e^{-\frac{(1-K)TR}{L}} + \frac{E}{R} \left(1 - e^{-\frac{(1-K)TR}{L}}\right) \\
 \Delta I &= I_2 e^{-\frac{TR}{L}} - \frac{E}{R} e^{-\frac{KT}{L}} + \frac{E}{R} e^{-\frac{TR}{L}} + \frac{V_S - E}{R} \left(1 - e^{-\frac{KT}{L}}\right) \\
 &\quad - I_2 e^{-\frac{(1-K)TR}{L}} + \frac{E}{R} \left(1 - e^{-\frac{(1-K)TR}{L}}\right) \\
 \Delta I &= I_2 e^{-\frac{TR}{L}} - \frac{E}{R} e^{-\frac{KT}{L}} + \frac{E}{R} e^{-\frac{TR}{L}} + \frac{V_S - E}{R} \\
 &\quad - \frac{V_S - E}{R} e^{-\frac{KT}{L}} - e^{-\frac{(1-K)TR}{L}} \left( I_2 e^{-\frac{KT}{L}} + \frac{V_S - E}{R} \left(1 - e^{-\frac{KT}{L}}\right) \right) \\
 &\quad + \frac{E}{R} - \frac{E}{R} e^{-\frac{(1-K)TR}{L}} \\
 &= \underbrace{I_2 e^{-\frac{TR}{L}}}_{\Delta I} - \frac{E}{R} e^{-\frac{KT}{L}} + \frac{E}{R} e^{-\frac{TR}{L}} + \frac{V_S - E}{R} - \frac{V_S - E}{R} e^{-\frac{KT}{L}} \\
 &\quad - \underbrace{I_2 e^{-\frac{TR}{L}}}_{\Delta I} - \frac{V_S - E}{R} e^{-\frac{(1-K)TR}{L}} + \frac{V_S - E}{R} e^{-\frac{TR}{L}} + \frac{E}{R} - \frac{E}{R} e^{-\frac{(1-K)TR}{L}} \\
 \Delta I \left(1 - e^{-\frac{TR}{L}}\right) &= \frac{V_S}{R} - \frac{V_S}{R} e^{-\frac{KT}{L}} - \frac{V_S}{R} e^{-\frac{(1-K)TR}{L}} + \frac{V_S}{R} e^{-\frac{TR}{L}} \\
 \Delta I &= \frac{V_S}{R} \frac{1 - e^{-\frac{KT}{L}} - e^{-\frac{(1-K)TR}{L}} + e^{-\frac{TR}{L}}}{1 - e^{-\frac{TR}{L}}}
 \end{aligned}$$

- If the output current is discontinuous, then the current waveform is as shown in the Figure below.

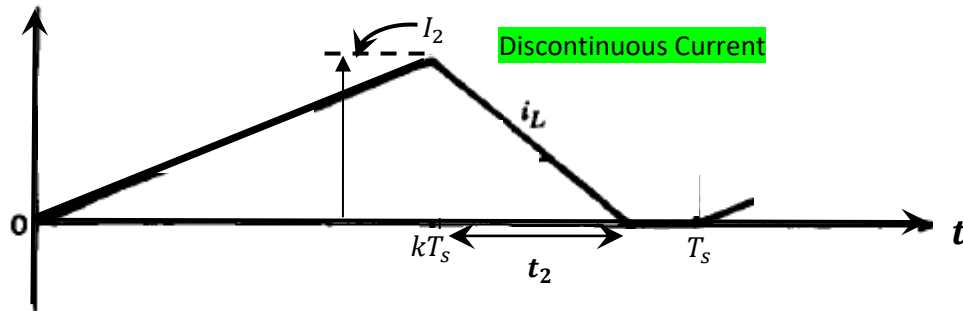

Then, the initial current for Mode '1' will be zero ( $I_1 = 0$ ), and the current in Mode '1' is:

$$i_1(t) = \frac{V_s - E}{R} \left( 1 - e^{-\frac{Rt}{L}} \right); \quad 0 \leq t \leq kT_s$$

Also, at the end of Mode 1,  $t = kT_s$ , the current is:

$$i_1(t = kT_s) = I_2 = \frac{V_s - E}{R} \left( 1 - e^{-\frac{RkT_s}{L}} \right)$$

During Mode '2', the current falls from its initial value,  $I_2$ , as:

$$i_2(t') = \frac{-E}{R} + \left( I_2 + \frac{E}{R} \right) e^{-\frac{Rt'}{L}}, \quad 0 \leq t' \leq t_2 \text{ such that } t_2 \leq (1 - k)T_s$$

Again, redefine the time origin such that  $t' = 0$  at the beginning of Mode '2'!

At the end of Mode '2', the current falls to zero (at  $t' = t_2$ );

$$i_2(t' = t_2) = I_3 = \frac{-E}{R} + \left( I_2 + \frac{E}{R} \right) e^{-\frac{Rt_2}{L}} = 0$$

Since the current is discontinuous, then the current is zero at the end of Mode '2';  $I_3 = I_1 = 0$ , then the necessary condition for discontinuous conduction can be found as:

$$t_2 = \frac{L}{R} \ln \left( 1 + \frac{RI_2}{E} \right)$$

and must be  $\leq (1 - k)T_s$ , if the current is to be discontinuous!

## 2) Principle of Step-up (Boost) Converter Operation

The basic circuit of a Boost converter is shown in the Figure below.

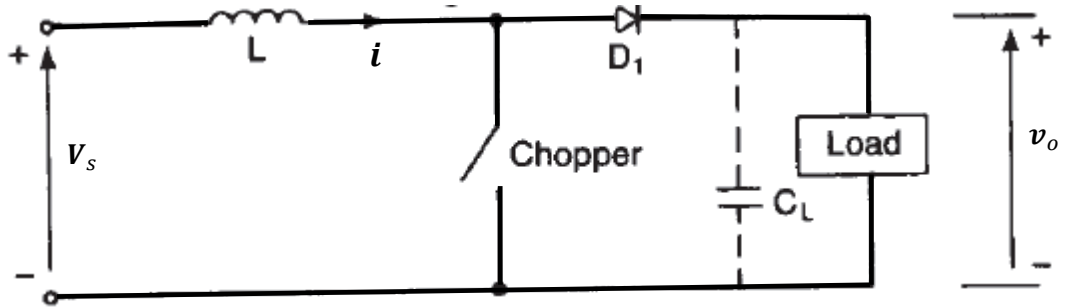

Assuming a continuous current conduction, the waveform is as shown in the Figure next.

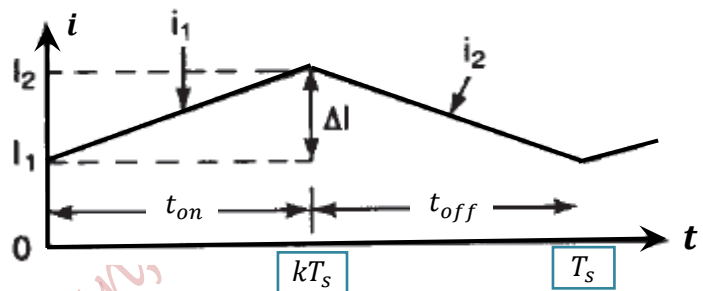

When the switch is closed (for  $t_{on}$ ), the inductor current rises. Applying KVL at the input yields:

$$V_L = L \frac{di(t)}{dt} = V_s$$

$$\Rightarrow \Delta I = \frac{V_s}{L} t_{on}$$

When the switch is opened (for  $t_{off}$ ), the current falls and the output voltage is:

$$v_o = V_s + L \frac{di(t)}{dt}$$

If a large capacitor " $C_L$ " is connected across the load, the output voltage will be continuous, and then, the average output voltage is:

$$V_o = V_s + L \frac{\Delta I}{t_{off}}$$

$$V_o = V_s + L \frac{\frac{V_s t_{on}}{L}}{t_{off}}$$

$$V_o = V_s + V_s \frac{t_{on}}{t_{off}} \Rightarrow V_o = V_s \left( 1 + \frac{t_{on}}{t_{off}} \right)$$

$$\Rightarrow V_o = V_s \left( \frac{t_{off} + t_{on}}{t_{off}} \right) \Rightarrow V_o = V_s \left( \frac{T_s}{(1-k)T_s} \right)$$

- Therefore, the average output voltage is:

$$V_o = \frac{V_s}{1-k}; \quad 0 < k < 1$$

- Note that, the minimum average output voltage is  $V_s$  at  $k = 0$ !
- The chopper cannot be switched 'on' continuously such that  $k = 1$ !

- A plot of a normalized  $V_o$  versus  $k$  is shown in the Figure next.

- For values of  $k$  tending to unity, the average output voltage becomes very large and very sensitive to changes in  $k$ ; operation in the unstable region must be avoided!

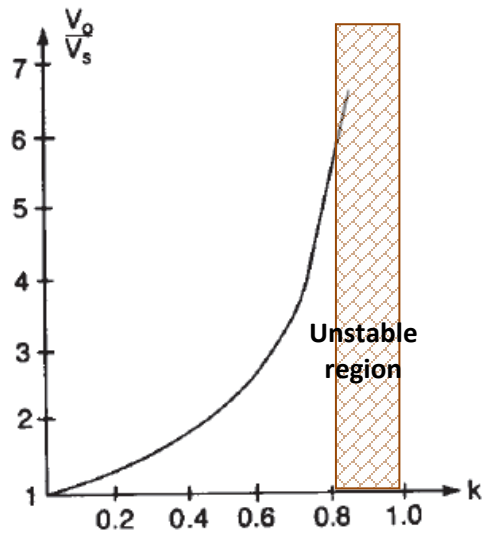

Dr. M. Abu-Khaizaram

### Boost Converter Applied in a Battery Charger

Consider the circuit shown in the Figure below, the battery 'E' is to be charged from the source 'V<sub>s</sub>'.

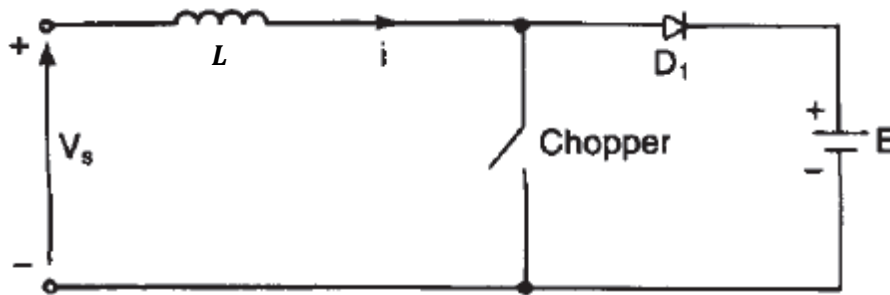

There are two modes of operation, as illustrated in the Figures below.

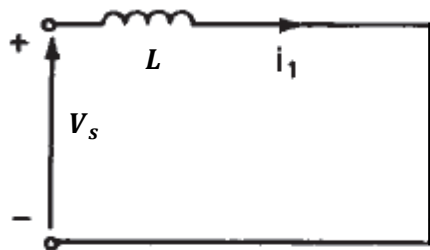

Mode 1

(The switch is closed)

(The diode is off)

(The inductor charges)

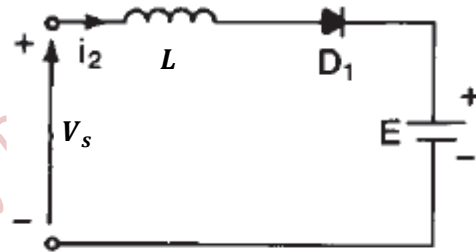

Mode 2

(The switch is opened)

(The diode is on)

(The inductor discharges)

For a continuous current conduction, the current waveform is shown in the Figure below.

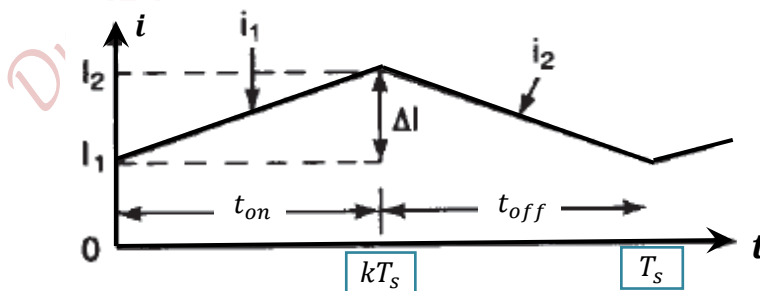

✚ For Mode 1 ( $0 \leq t \leq kT_s$ ), applying KVL yields:

$$V_s = L \frac{di_1(t)}{dt}$$
$$i_1(t) = \frac{V_s}{L} t + I_1$$

where,  $I_1$  is the initial current for Mode '1'!

During Mode '1', the inductor current must rise, and the necessary condition is:

$$\frac{di_1(t)}{dt} > 0 \text{ or } \frac{V_s}{L} > 0; \text{ i.e., } V_s > 0$$

The source ' $V_s$ ' is connected with its polarity as shown in the previous circuits.

✚ For Mode 2 ( $0 \leq t' \leq (1 - k)T_s$ ), applying KVL yields:

$$V_s = L \frac{di_2(t)}{dt} + E$$
$$i_2(t) = \frac{V_s - E}{L} t' + I_2$$

where,  $I_2$  is the initial current for Mode '2'!

✚ For a stable system, the current must fall during Mode '2' and the necessary condition is:

$$\frac{di_2(t)}{dt} < 0 \text{ or } \frac{V_s - E}{L} < 0; \text{ i.e., } V_s < E$$

✚ Therefore, for a controllable energy transfer, the combined condition is:

$$0 < V_s < E$$

With the previous configuration (the boost converter), the energy can be transferred from one source ( $V_s$ ) to another source ( $E$ ), whose voltage value is higher than the first one (the source voltage ( $V_s$ ) is less than the voltage of the battery ( $E$ ) being charged!).

### 3) Step-down/Step-up (Buck-Boost) Regulator (Converter)

- A Buck-Boost regulator provides an output voltage, which could be less than or greater than the input voltage.
- The output voltage polarity is opposite to the polarity of the input voltage.
- The circuit topology of a Buck-Boost converter is shown in the Figure below.

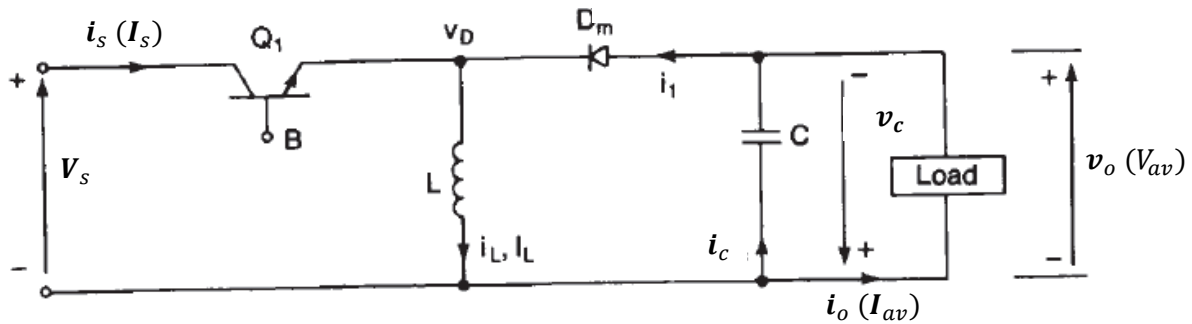

- There are two modes of operation:

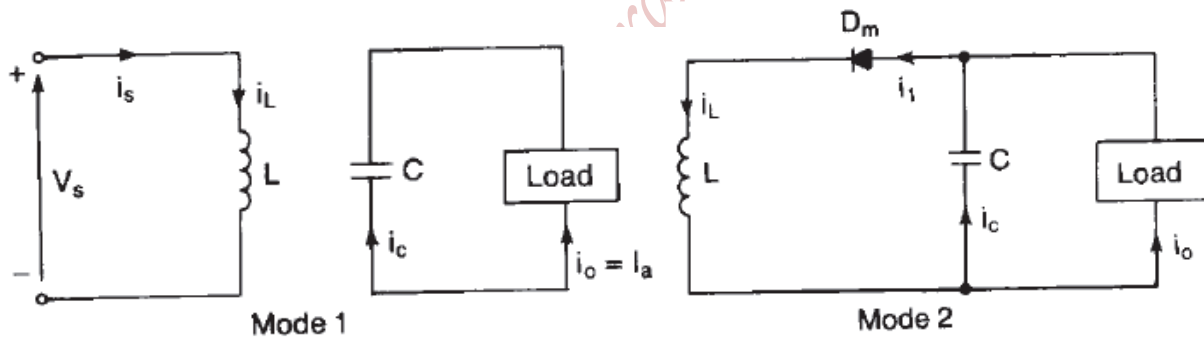

(The switch is closed)

(The diode is off)

(The inductor charges,  
the capacitor discharges)

(The switch is opened)

(The diode is on)

(The inductor discharges  
the capacitor charges)

✚ For continuous current conduction, and assuming a linear current rise/fall, the waveforms are shown in the Figure below.

✚ In Mode 1 ( $0 \leq t \leq kT_s$ ), the current rises from  $I_1$  to  $I_2$  during  $t_{on}$ .

Applying KVL yields:

$$V_s = L \frac{di_1(t)}{dt}$$

$$V_s = L \frac{I_2 - I_1}{t_{on}}$$

$$V_s = L \frac{\Delta I}{t_{on}}$$

$$\therefore t_{on} = L \frac{\Delta I}{V_s} \dots\dots(1)$$

$$\text{and } \Delta I = \frac{V_s}{L} t_{on} \dots\dots(2)$$

where,  $\Delta I$  is the peak-to-peak current ripple!

✚ In Mode 2 ( $kT_s \leq t \leq T_s$ ), the current falls linearly from  $I_2$  to  $I_1$  in  $t_{off}$ . Assuming an average output voltage,  $V_{av}$ , and applying KVL yields:

$$V_L = V_{av} = L \frac{I_1 - I_2}{t_{off}}$$

$$V_{av} = -L \frac{I_2 - I_1}{t_{off}}$$

$$V_{av} = -L \frac{\Delta I}{t_{off}}$$

$$t_{off} = -L \frac{\Delta I}{V_{av}} \dots\dots(3)$$

$$\Delta I = -\frac{V_{av}}{L} t_{off} \dots\dots(4)$$

✚ Equating eqs. (2) and (4) yields:

$$\Delta I = \frac{V_s}{L} t_{on} = -\frac{V_{av}}{L} t_{off}$$

But,  $t_{on} = kT_s$  and  $t_{off} = (1 - k)T_s$

$$V_s kT_s = -V_{av}(1 - k)T_s$$

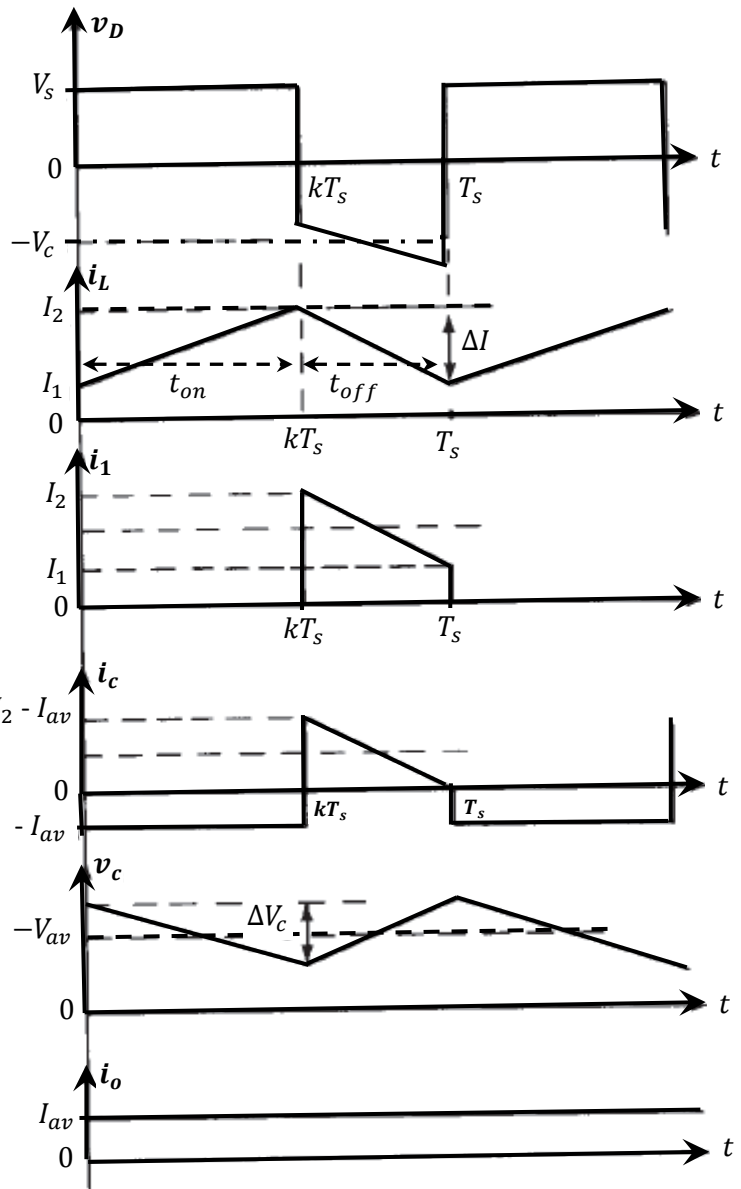



Therefore, the average output voltage of the Buck-Boost converter is:

$$V_{av} = -\frac{k}{1-k} V_s$$

The average output voltage and the converter's operation depend on the value of  $k$ ;

If  $k < 0.5$ , then  $|V_{av}| < |V_s| \Rightarrow$  Step-down operation

If  $k = 0.5$ , then  $V_{av} = -V_s \Rightarrow$  Inverting operation

If  $k > 0.5$ , then  $|V_{av}| > |V_s| \Rightarrow$  Step-up operation

### Input/Output Currents Relationship:

Assuming a lossless converter, then the power supplied equals the power consumed;

$$I_s V_s = -I_{av} V_{av}$$

Note that, the negative sign is used, because the power is considered to be consumed if the current enters the positive terminal; but here the current enters the negative terminal.

Also note that,  $I_s$  is the average input current, whilst  $I_{av}$  is the average output current!

Substituting for the average output voltage in the balanced power equation yields:

$$I_s V_s = -I_{av} \left( -\frac{k}{1-k} V_s \right)$$

The average input current is:

$$\Rightarrow I_s = \frac{k}{1-k} I_{av}$$

Note that, the converter acts as a transformer but for DC variables in stepping up/down the current/voltage, whilst keeping the power constant!

### The Inductor Current Ripple:

Substituting for  $t_{on} = kT_s$  and rearranging equation (2) yield:

$$\Delta I = \frac{V_s}{L} t_{on}$$

$$\Delta I = \frac{V_s}{L} kT_s$$

$$\Delta I = \frac{kV_s}{Lf_s}$$

### ✚ The Output Voltage Ripple:

When the switch is 'on', the capacitor supplies the load current, and the average capacitor current equals the average load current;

$$I_c = I_{av}$$

The capacitor voltage is related to its current by:

$$\Delta V_c = \frac{1}{C} \int_0^{t_{on}} I_c dt$$

$$\Delta V_c = \frac{1}{C} \int_0^{t_{on}} I_{av} dt$$

$$\Delta V_c = \frac{I_{av}}{C} t_{on}$$

But,  $t_{on} = kT_s$ , then:

$$\Delta V_c = \frac{I_{av}}{C} kT_s$$

$$\Rightarrow \Delta V_c = \frac{kI_{av}}{f_s C}$$

Compare the above formula with the voltage ripple at the output of a rectifier with a capacitor smoothing!

### Example 7-6

The buck–boost regulator in Fig. 7-9a has an input voltage of  $V_s = 12$  V. The duty cycle,  $k = 0.25$  and the switching frequency is 25 kHz. The inductance,  $L = 150$   $\mu$ H and filter capacitance,  $C = 220$   $\mu$ F. The average load current,  $I_a = 1.25$  A. Determine the (a) average output voltage,  $V_a$ ; (b) peak-to-peak output voltage ripple,  $\Delta V_c$ ; (c) peak-to-peak ripple current of inductor,  $\Delta I$ ; and (d) peak current of the transistor,  $I_p$ .

**Solution**  $V_s = 12$  V,  $k = 0.25$ ,  $I_a = 1.25$  A,  $f = 25$  kHz,  $L = 150$   $\mu$ H, and  $C = 220$   $\mu$ F.

(a) From Eq. (7-58),  $V_a = -12 \times 0.25 / (1 - 0.25) = -4$  V.

(b) From Eq. (7-65), the peak-to-peak output ripple voltage is

$$\Delta V_c = \frac{1.25 \times 0.25}{25,000 \times 220 \times 10^{-6}} = 56.8 \text{ mV}$$

(c) From Eq. (7-62), the peak-to-peak inductor ripple is

$$\Delta I = \frac{12 \times 0.25}{25,000 \times 150 \times 10^{-6}} = 0.8 \text{ A}$$

(d) From Eq. (7-59),  $I_s = 1.25 \times 0.25 / (1 - 0.25) = 0.4167$  A. Since  $I_s$  is the average of duration  $kT$ , the peak-to-peak current of the transistor,

$$I_p = \frac{I_s}{k} + \frac{\Delta I}{2} = \frac{0.4167}{0.25} + \frac{0.8}{2} = 2.067 \text{ A}$$

#### 4) Full Bridge DC-to-DC Converter

- The circuit topology of a Full-Bridge converter is shown in the Figure below.

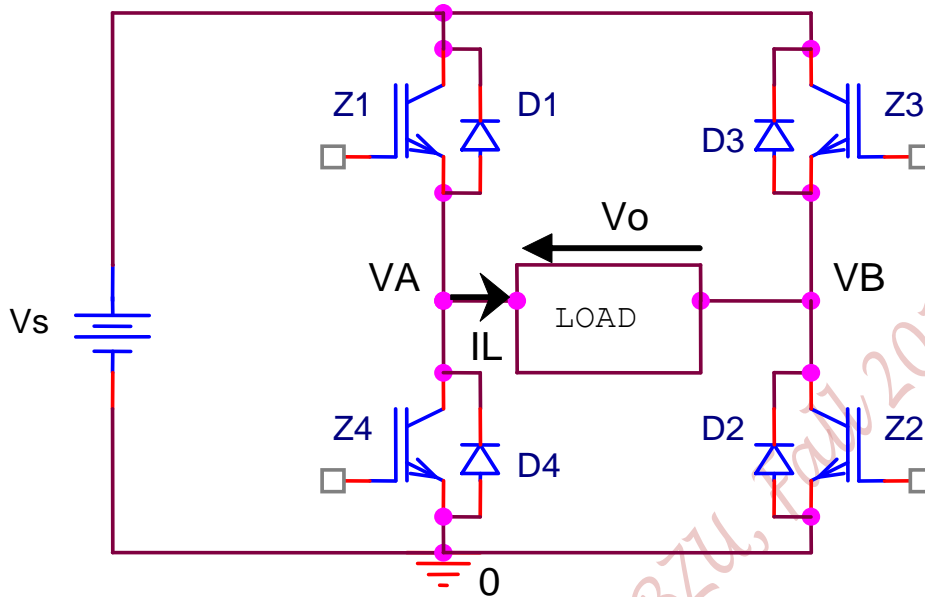

- Each leg of the bridge is made up of two switches, here IGBTs, each with a diode in inverse parallel. The switches could be any other type of controllable switches; e.g. a Power MOSFET, a Power BJT, an IGCT, or a GTO...
- If the switch does not have any diode, an external anti-parallel diode must be connected across each switch. If MOSFETs are used, the diodes can be the body diodes if the switching frequency (speed),  $f_s$ , is modest, or external fast-reverse recovery diodes for higher switching frequencies.
- The load could be the armature of a DC motor; a back emf in series with resistance and inductance.
- A number of ways of controlling the bridge exists. It is usual to have one of the two IGBTs in each leg conducting at a given time, although in practice a **Dead Time (Underlap Period)**, when both switches are off, **1 $\mu$ s - 5 $\mu$ s**, is allowed **to avoid shorting the DC bus**.
- Provided that, in a given leg one transistor is 'on', the average (mean) output voltage can be established!

- If the load current,  $I_L$ , is positive, then there are two possible current paths depending the switching states of the bridge, as marked on the Figures below. Note that, the inductive load maintains the current in the same direction, as its time constant is much larger than the switching period.

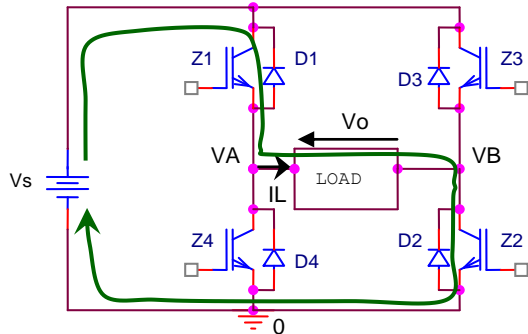

$Z_1$  &  $Z_2$  are 'on' and  $Z_3$  &  $Z_4$  are 'off'

$$v_A = V_s \text{ and } v_B = 0$$

$I_L$  builds up

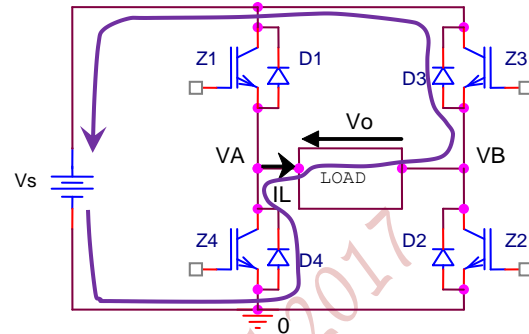

$Z_1$  &  $Z_2$  are 'off' and  $Z_3$  &  $Z_4$  are 'on'

$$v_A = 0 \text{ and } v_B = V_s$$

$I_L$  decays

where,  $v_A$  and  $v_B$  are the mid points' voltages with respect to ground!

- If the load current,  $I_L$ , is negative, then there are also two possible current paths depending the switching states of the bridge, as marked on the Figures below.

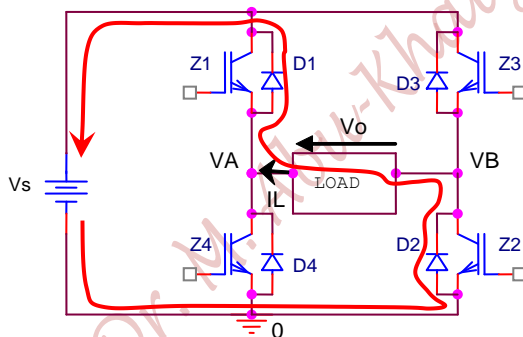

$Z_1$  &  $Z_2$  are 'on' and  $Z_3$  &  $Z_4$  are 'off'

$$v_A = V_s \text{ and } v_B = 0$$

$I_L$  decays

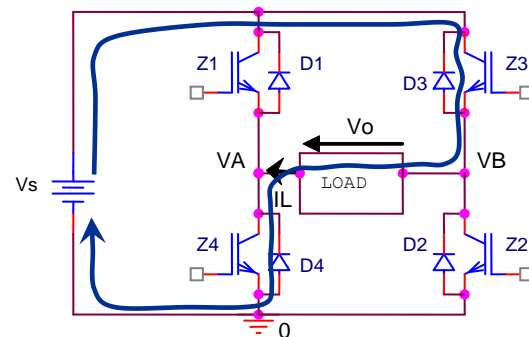

$Z_1$  &  $Z_2$  are 'off' and  $Z_3$  &  $Z_4$  are 'on'

$$v_A = 0 \text{ and } v_B = V_s$$

$I_L$  builds up

- The voltages of the midpoints with respect to ground ( $v_A$  and  $v_B$ ) depend only on the switches setup, not the direction of current. Other combinations are possible.

- The average value of  $v_A$  is:

$$V_A = k_A V_s$$

where  $k_A$  is the fraction of the switching period for which  $Z_1$  is 'on', and is called the duty cycle of Leg 'A' (or  $Z_1$ ),  $0 \leq k_A \leq 1$ !

- Similarly, for the other leg, the average midpoint voltage is:

$$V_B = k_B V_s$$

where  $k_B$  is the duty cycle of Leg 'B' (or  $Z_3$ ), such that  $0 \leq k_B \leq 1$ !

- The instantaneous output voltage between the two midpoints is:

$$v_o = v_A - v_B$$

- Two switching strategies using Pulse Width Modulation (PWM)** can be implemented to generate the duty cycle of the two legs:

- A) Pulse Width Modulation (PWM) with **Bipolar switching**, which involves treating ( $Z_1$  &  $Z_2$ ) and ( $Z_3$  &  $Z_4$ ) as pairs
- B) Pulse Width Modulation (PWM) with **Unipolar switching**, where each leg is operated independently

### A) Output Voltage of a DC-to-DC Full Bridge with Bipolar Switching

The average output voltage,  $V_o$ , is:

$$V_o = V_A - V_B$$

$$V_o = k_A V_s - k_B V_s$$

Assuming a negligible Dead time, the two duty cycles are related by:

$$k_B = 1 - k_A$$

Therefore, the average output voltage is:

$$V_o = (2k_A - 1)V_s$$

$V_o$  can be varied from  $-V_s$  to  $+V_s$  by varying the duty cycle,  $k_A$ , from '0' to '1'!

At  $k_A = 0.5$ , the average output voltage is zero, and the output is a square wave; the bridge is operating as a single phase inverter in a square wave mode.

### Generation of the Duty Cycle ( $k_A$ ) for Bipolar Switching

- The control of the Pulse Width Modulation uses a triangular waveform of amplitude  $\hat{V}_t$  and a control voltage ( $v_c$ ).
- The switching waveforms are shown in the Figure below.

- The control is based on a comparison between a control voltage ( $v_c$ ) and a triangular voltage ( $v_t$ ), and then the output:

$$v_o = v_A - v_B \text{ is established;}$$

When  $v_c > v_t$ , (period II),

$Z_1$  &  $Z_2$  are 'on' and  $Z_3$  &  $Z_4$  are 'off',

$$v_A = V_s \text{ and } v_B = 0, \text{ and } v_o = V_s$$

When  $v_c < v_t$ , (period I),

$Z_1$  &  $Z_2$  are 'off' and  $Z_3$  &  $Z_4$  are 'on',

$$v_A = 0 \text{ and } v_B = V_s, \text{ and } v_o = -V_s$$

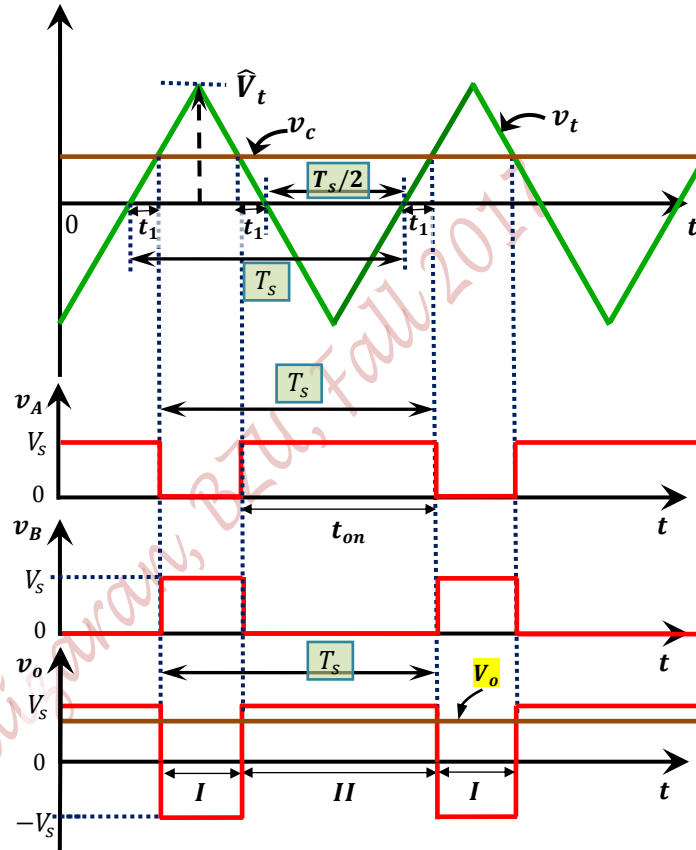

- Since the output voltage alternates between  $V_s$  and  $-V_s$ , this method is called Bipolar!

- In period I,  $Z_3$  &  $Z_4$  are 'on'
- In period II,  $Z_1$  &  $Z_2$  are 'on'

- The duty cycle ( $k_A$ ) is set by the time for which the triangular waveform ( $v_t$ ) does not exceed a control voltage ( $v_c$ ). From the previous Figure, the 'on' time for ( $Z_1$  &  $Z_2$ ),  $t_{on}$ , is:

$$t_{on} = t_1 + t_1 + \frac{T_s}{2}$$

From similar triangles; the time,  $t_1 = \frac{v_c}{\hat{v}_t} \left( \frac{T_s}{4} \right)$

$$t_{on} = 2 \frac{v_c}{\hat{v}_t} \left( \frac{T_s}{4} \right) + \frac{T_s}{2}$$

$$t_{on} = \frac{v_c}{\hat{v}_t} \left( \frac{T_s}{2} \right) + \frac{T_s}{2}$$

Therefore, the duty cycle of  $Z_1$  (or  $Z_2$ ) is:

$$k_A = \frac{t_{on}}{T_s} = \frac{1}{2} \left( 1 + \frac{v_c}{\hat{v}_t} \right)$$

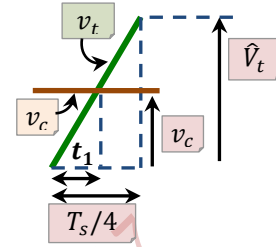

- Substituting for  $k_A$  in the average output voltage equation yields:

$$V_o = (2k_A - 1)V_s$$

$$V_o = \left( 2 \frac{1}{2} \left( 1 + \frac{v_c}{\hat{v}_t} \right) - 1 \right) V_s$$

$$\Rightarrow V_o = \left( \frac{v_c}{\hat{v}_t} \right) V_s$$

where,  $-1 < \frac{v_c}{\hat{v}_t} < 1$

The average output voltage can also be expressed as a function of the control voltage:

$$V_o = \left( \frac{V_s}{\hat{v}_t} \right) v_c$$

$$\Rightarrow V_o = k_1 v_c$$

where  $k_1$  is a constant depending on  $V_s$  and  $\hat{v}_t$ .

Note that, the average output voltage  $V_o$  varies linearly with  $v_c$ !

$V_o$  varies from  $-V_s$  to  $V_s$ !

## B) Output Voltage of a DC-to-DC Full Bridge with Unipolar Switching

- ❖ Unipolar exploits the fact that  $v_o$  is zero if  $Z_1$  &  $Z_3$  are both 'on' or  $Z_2$  &  $Z_4$  are both 'on'.
- ❖ The switching waveforms are shown in the Figure below.

- ❖ The control of the Pulse Width Modulation uses a triangular waveform of amplitude  $\hat{V}_t$  and two control voltages;  $v_c$  &  $-v_c$ .

- ❖ The switches in Leg 'A' are controlled by  $v_c$ , and those in Leg 'B' are controlled by  $-v_c$ .

❖ If  $v_c > v_{t1}$

$Z_1$  is 'on' (and  $Z_4$  is 'off') and  $v_A = V_s$ ;

Otherwise,

$Z_1$  is 'off' (and  $Z_4$  is 'on') and  $v_A = 0$ !

❖ If  $-v_c > v_{t1}$

$Z_3$  is 'on' (and  $Z_2$  is 'off') and  $v_B = V_s$ ;

Otherwise,

$Z_3$  is 'off' (and  $Z_2$  is 'on') and  $v_B = 0$ !

- ❖ In period I,  $Z_2$  &  $Z_4$  are 'on'
- In period II,  $Z_1$  &  $Z_2$  are 'on'
- In period III,  $Z_1$  &  $Z_3$  are 'on'
- In period IV,  $Z_1$  &  $Z_2$  are 'on'

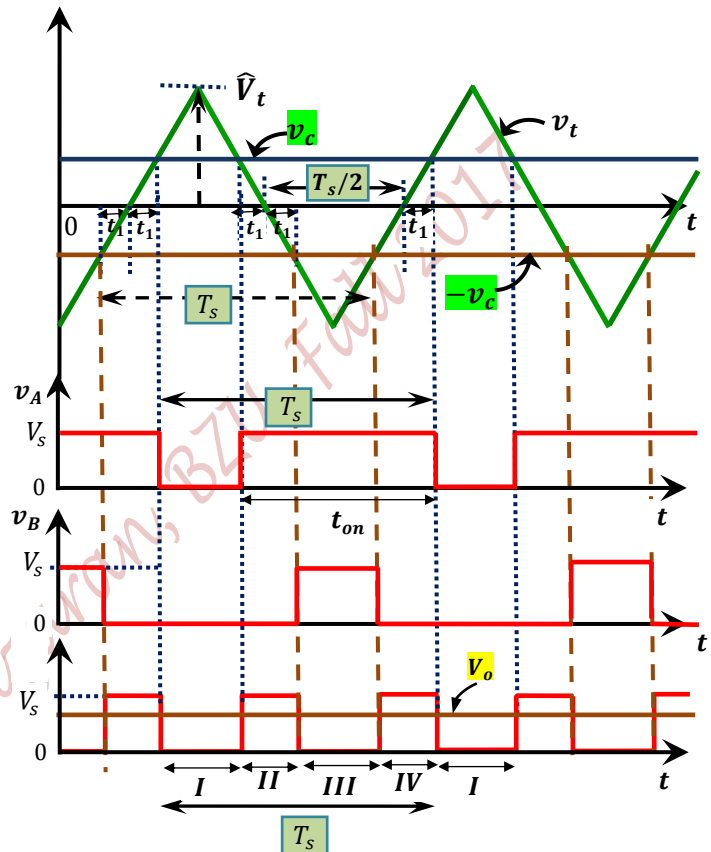



- ❖ As with Bipolar switching, the duty cycle for Leg 'A' ( or  $Z_1$ ) is:

$$k_A = \frac{1}{2} \left( 1 + \frac{v_c}{\hat{V}_t} \right)$$

and from the diagram, the two duty cycles for the two legs are related as:

$$k_B = 1 - k_A$$

- ❖ The average output voltage is the same as that with Bipolar switching and is equal to:

$$V_o = (2k_A - 1)V_s$$

Also, it varies from  $-V_s$  to  $V_s$ , as  $k_A$  varies from '0' to '1'!

Also, the average output voltage with Unipolar switching can be expressed as a function of the control voltage:

$$V_o = \left( \frac{V_s}{\hat{V}_t} \right) v_c$$

$$\Rightarrow V_o = k_1 v_c$$

where  $k_1$  is a constant depending on  $V_s$  and  $\hat{V}_t$ .

Note that,  $V_o$  varies linearly with  $v_c$ !

- ❖ **For the same switching frequency, the Unipolar strategy results in a lower ripple in the load voltage. That is because, the effective switching frequency at the output with Unipolar strategy is twice that of the Bipolar approach, although the switching frequency in each leg (and the switching losses in the switches) is the same for the two methods.**

## Choppers' Classification According to Power Flow

### 1) Class 'A' Chopper:

- The power flows from the source to the load.
- It has one quadrant of operation, the first quadrant of v-i characteristic; e.g. Step-down chopper.

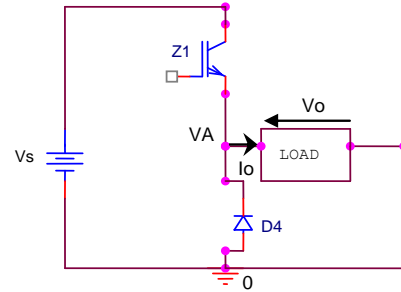
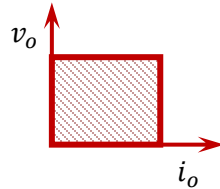

### 2) Class 'B' Chopper:

- The power flows from the load to the source.
- It operates in the second quadrant of the v-i characteristic.
- It is appropriate for regenerative braking of DC motors.

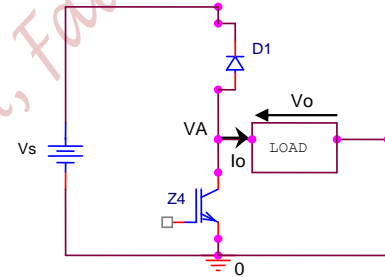
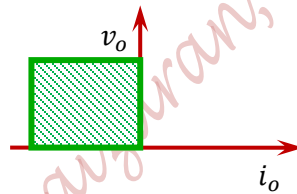

### 3) Class 'C' Chopper:

- The power flows in both directions; from the load to the source, and vice versa.
- It has two quadrants of operation; the first and the second quadrants of the v-i characteristic.
- It is appropriate for motoring and regenerative braking of DC motors; e.g. Half Bridge DC-to-DC converter.

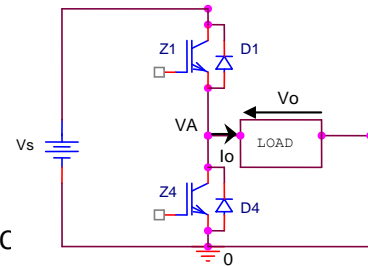
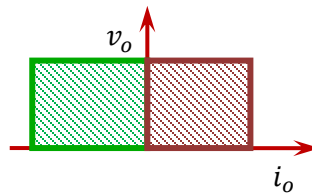

#### 4) Class 'D' Chopper:

- The power flows in both directions; from the load to the source, and vice versa.
- It has two quadrants of operation; the first and the **fourth** quadrant of the v-i characteristic.
- It is appropriate for motoring and braking of DC motors.

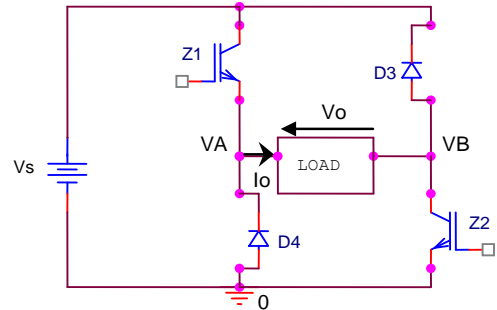
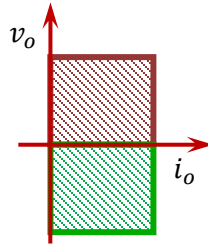

#### 5) Class 'E' Chopper:

- The power flows in both directions; from the load to the source, and vice versa.
- It has four quadrants of operation.
- It is appropriate for motoring and braking of DC motors in the forward and reverse directions; e.g. the Full-Bridge DC-to-DC converter.

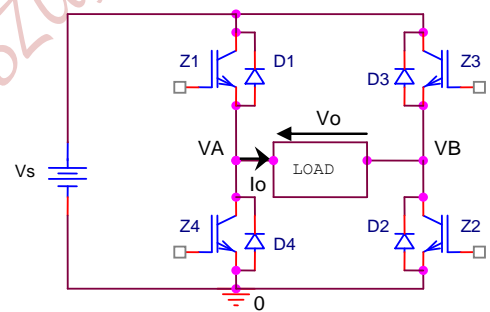
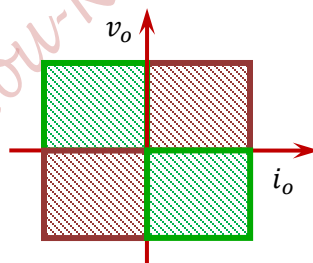

Dr. M. Abu-Khaizaran, BZU, Fall 2017

---

# Part VI: DC-to-AC Converters (Power Electronic Inverters)

---

## Introduction:

Inverters are power electronic circuits designed to convert a DC Voltage (or Current) into an AC Voltage (or Current). The output of these inverters consists of a fundamental component of voltage or current, plus other (undesired) components at higher frequencies called harmonics.

## Main Types of Inverters:

### 1) Voltage Source Inverters (VSIs)

The input to the inverter is assumed to be a constant DC voltage source; it could be a rectified AC supply with a filter. A typical three-phase Voltage Source Inverter (VSI) is shown in the Figure below.

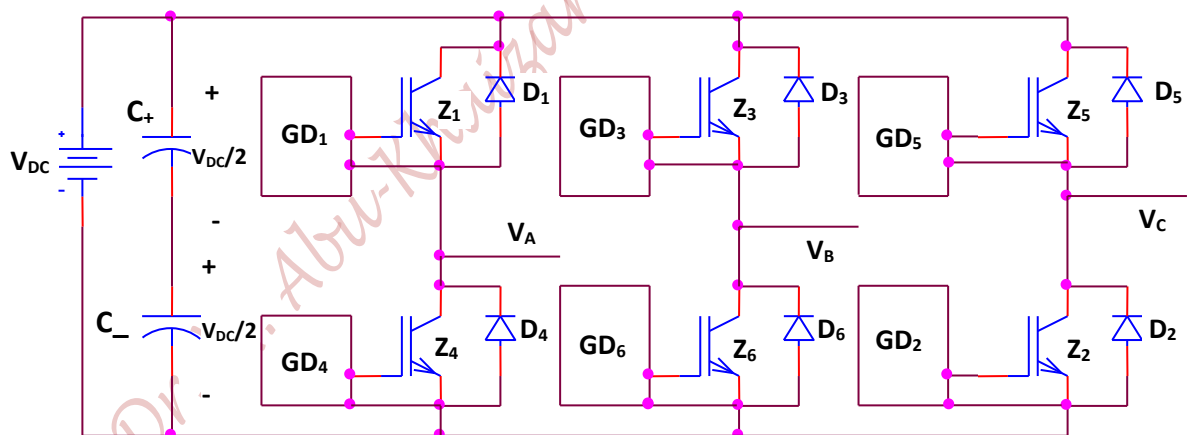

- ◆ The switches in a VSI have the ability to conduct current in both directions (upwards and downwards).
- ◆ Therefore, each switch has an anti-parallel diode; either the body diode or an external fast reverse recovery diode.
- ◆ A **Dead time (Underlap period)** between switches in the same leg, where both switches are off, should elapse **before turning on the off-switch**. Typically, the Dead time ranges from  $1\mu s$  to  $5\mu s$ , depending on the switching speed of the switches used, the circuit's topology and layout, and power level.

## 2) Current Source Inverters (CSIs)

The input to the inverter is assumed to be a constant DC current source. A voltage source in series with a large inductor represents a current source. A typical three-phase Current Source Inverter (CSIs) is shown in the Figure below.

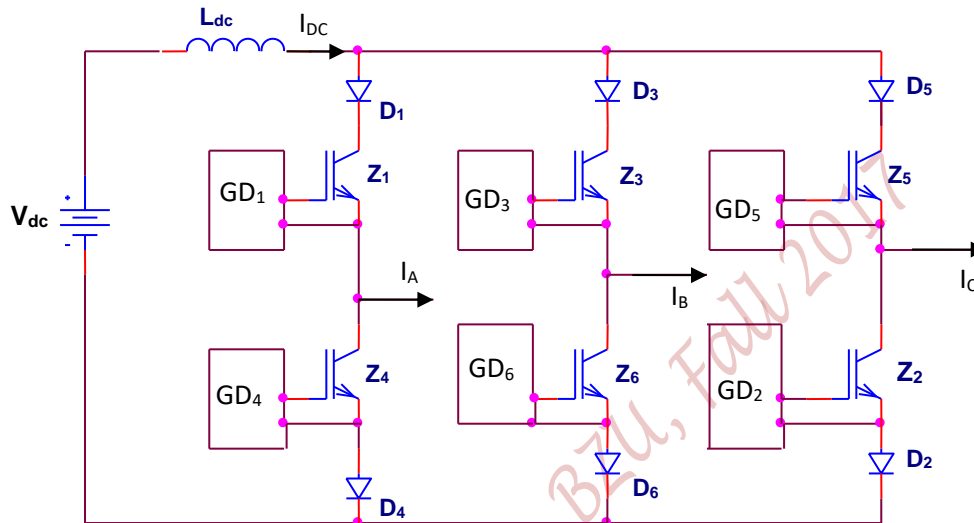

- ◆ The switches in a CSI have the ability to support (block) voltage of both polarities.
- ◆ Therefore, each switch has a reverse blocking capability; if switches with only forward blocking capabilities are used, a diode is connected in series with each switch to attain reverse blocking capability.
- ◆ An Overlap time (period) between switches in the same level of the inverter (upper or lower), where both switches are on, should elapse **before turning off the conducting switch**. Typically, the Overlap time ranges from  $1\mu\text{s}$  to  $5\mu\text{s}$ , depending on the switching speed of the switches used, circuit's topology and layout, and the power level.

## Applications:

The main applications of inverters are AC Motor Drives, Uninterruptable Power Supplies (UPSs), and Interconnection of PhotoVoltaic (PV) and Wind electric system with the Utility Grid. Inverters are essential components in renewable energy systems.



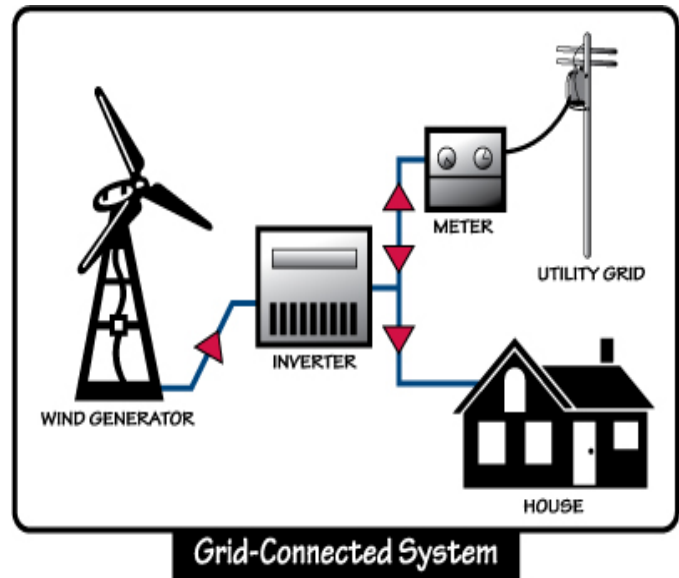
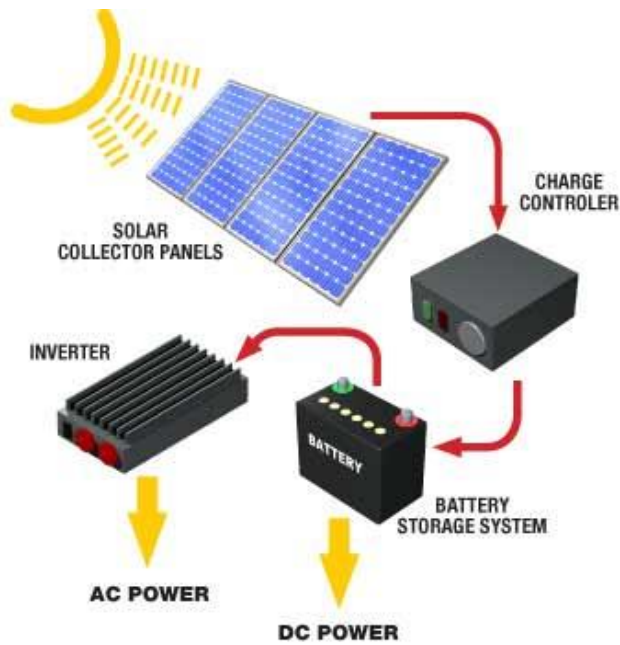

## Hybrid Power Systems

Combine multiple sources to deliver non-intermittent electric power

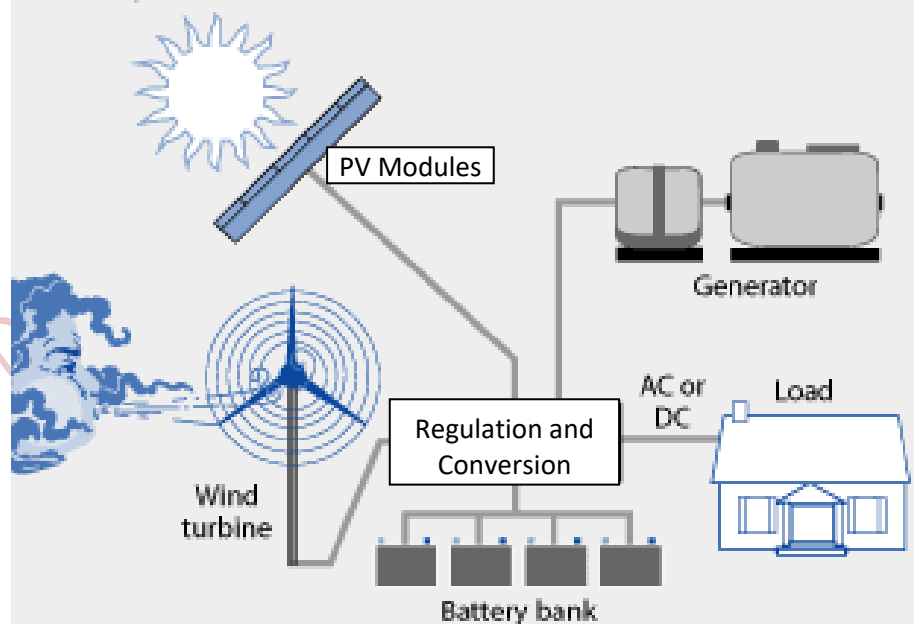



## Switching Schemes

Since the output of these inverters follows the control voltage of gates/bases of the controllable switches, various switching schemes can be employed to obtain an AC output of the various types of inverters. These schemes vary in their complexity, quality of output, switching losses, harmonic content and magnitude of AC gain. Some of these:

### 1. Square Wave Strategy

The gate/base control signals have a square wave shape with a duty cycle of half the period. This method is simple, but the harmonic content is high! This method will be studied in details later.

### 2. Sinusoidal Pulse Width Modulation (SPWM) Method

Since the desired outputs are sinusoidal, the control signal(s) has(ve) a sinusoidal shape. Therefore, the outputs are more closely sinusoidal with less harmonic content.

The control voltage is compared with a triangular voltage to produce the gate signals of the controllable switches, as shown in the Figure next.

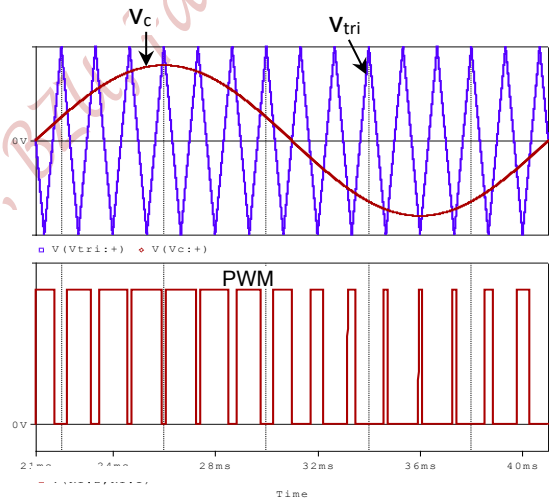

### 3. Sinusoidal Pulse Width Modulation with Third Harmonic Injection Method

This method is applicable to three-phase inverters. Each control signal, which is sinusoidal, has an added Third Harmonic signal to increase the AC gain compared to that of SPWM method. The frequency of the Third Harmonic signal is three times that of the fundamental frequency, but its magnitude is fractions of the magnitude of the sinusoidal signal.

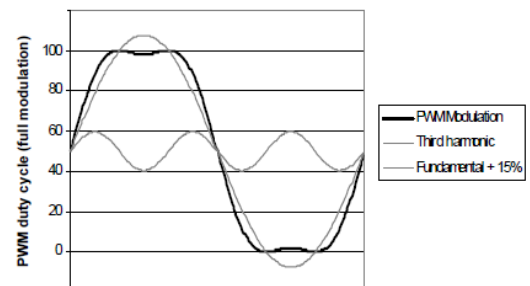

The per-unit modified control voltage (Third Harmonic Modulation Equation) is:

$$v_c(t) = \frac{2}{\sqrt{3}} \sin \omega t + \frac{1}{3\sqrt{3}} \sin 3\omega t$$

$$\Rightarrow v_c(t) = 1.155 \sin \omega t + 0.1925 \sin 3\omega t$$

The amplitude of the Modified reference control voltage cannot exceed 100%, but its fundamental component can. This produces a fundamental output voltage higher than that is obtained from SPWM by about 15.5%. Consequently, this method provides a better utilization of the DC supply.

Three-Phase Modified Sinusoidal Voltages with Third Harmonic Injection are in the Figure next.

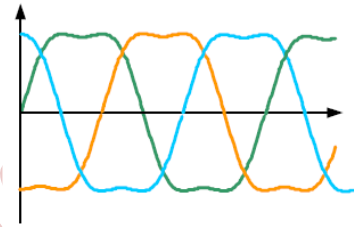

#### 4. Harmonic Elimination Method

The outputs are shaped with a number of notches removed at specified angles calculated by a microprocessor or a microcontroller in order to eliminate particular harmonics.

#### 5. Space Vector Modulation (SVM) Scheme

The three phase outputs are formed according to switching states sequence of the inverter switches. This method has a higher AC Gain compared with SPWM, less switching losses, and it is more feasible for digital implementation. This scheme will be studied in more details later in this course.

**The AC Gain ( $G_{AC}$ )** is defined as the maximum value of the fundamental component of the line-to-line voltage to the amplitude of the unfiltered pulses comprising the same component (the DC value).

For a three-phase Voltage Source Inverter, the **AC Gain** is defined as:

$$G_{AC} = \frac{\hat{V}_{LL1}}{V_{DC}} \Big|_{M=1}$$

# 1) Square Wave Operation of Voltage Source Inverters

## 1.1) Single Phase Voltage Source Inverter (Full Bridge as a DC-to-AC Converter)

### A. Single Phase VSI in Square Wave Mode

The Full Bridge can be operated in a **Square Wave Mode** to function as a single-phase Voltage Source Inverter producing an AC voltage at the output. The Figure below shows the circuit diagram of a single-phase VSI implementing IGBTs as switches.

Each of the inverter switches is 'on' for one half of a cycle ( $180^\circ$ ) of the desired output frequency ( $f_1$ ).

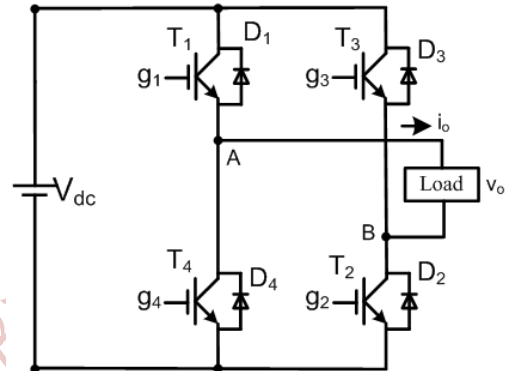

- The output square wave consists of an infinite number of sinusoidal voltages; a fundamental component and other high frequency components (harmonics).
- The frequency at the output ranges from few Hz up to MHz.
- The frequency can be adjusted by varying the frequency ( $f_1 = \frac{1}{T}$ ) of the controlling signals.
- The Figure next page shows the gate-emitter voltages of the IGBTs, the output voltages of the mid points of inverter legs with respect to the negative terminal of the supply, and the output voltage of a single-phase VSI with a Square Wave Mode.
- The Frequency Analysis gives the amplitude of the output at the fundamental frequency  $f_1$  ( $= \frac{1}{T}$ ) as:

$$\hat{V}_{o1} = \frac{4}{\pi} V_{DC} = 1.273 V_{DC}$$

- The amplitude of the AC output can be controlled by varying the DC input voltage, which could, for example, be derived from a Boost converter.

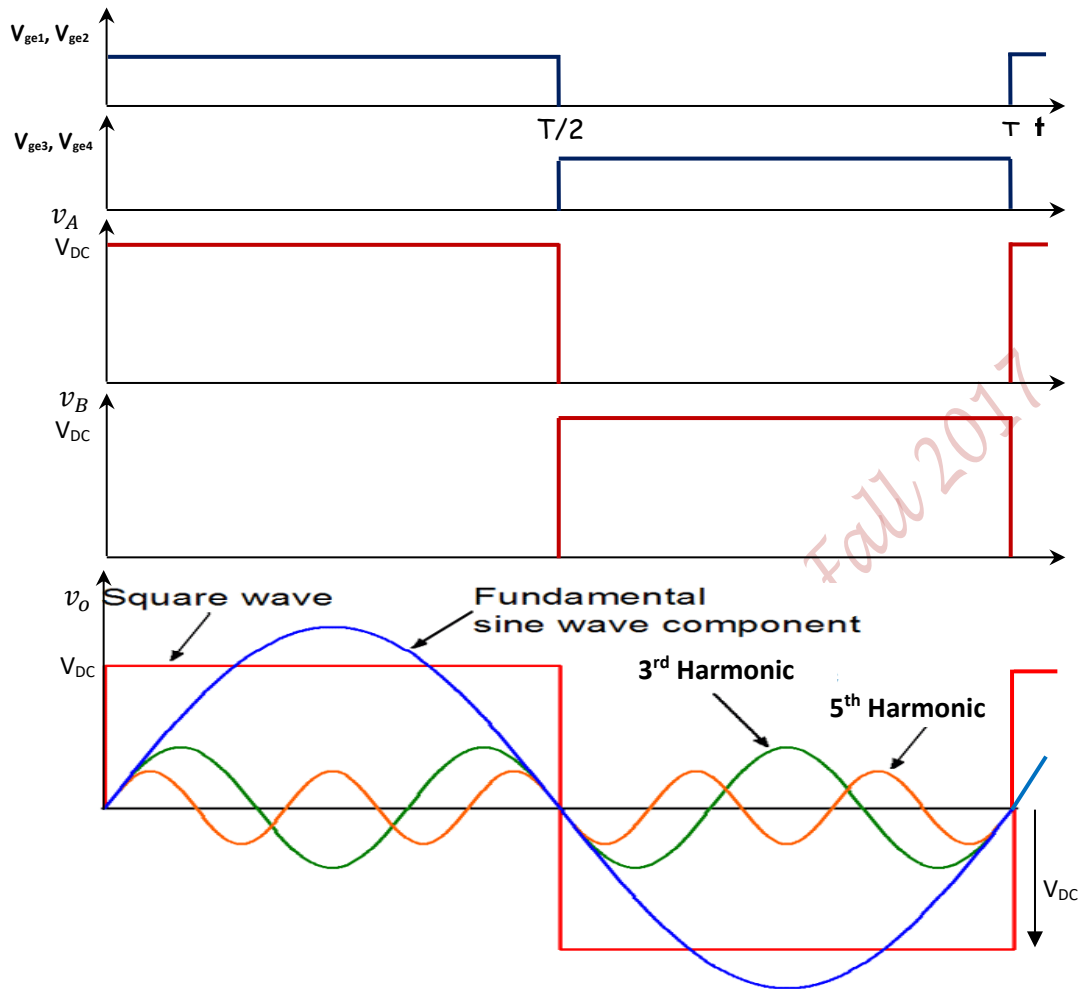

The harmonic components of the output are:

$$\hat{V}_{oh} = \frac{V_{o1}}{h} = \frac{4}{h\pi} V_{DC}$$

where  $h$  takes odd values only!

Thus, the Frequency Spectrum of the output in a Square Wave Mode is shown in the Figure below.

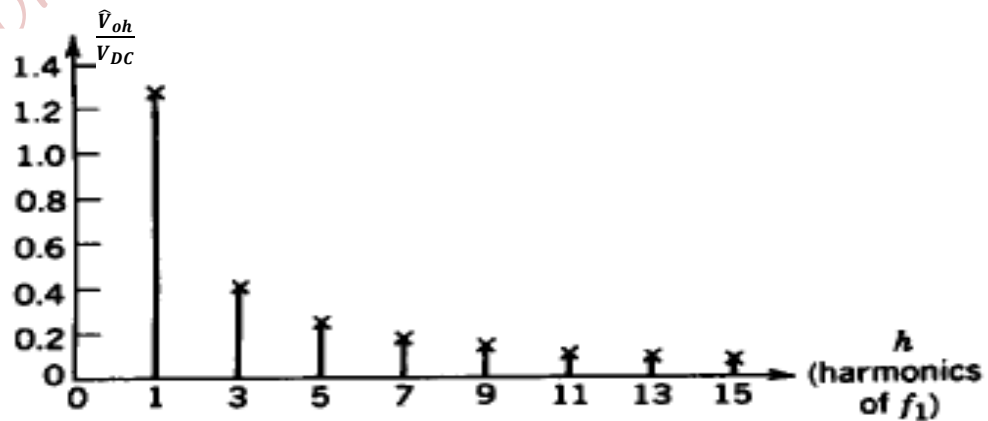

## B. Single Phase VSI Voltage Cancellation Method for Square Wave Mode

➤ The AC output voltage and its harmonic content can be varied by switching the legs of the inverter independently. The duty cycle of Leg A ( $k_A$ ) is made equal to the duty cycle of Leg B ( $k_B$ ) and equals 0.5. But, the switching is phase shifted with an angle (delay),  $\alpha$ , between the two legs, so that the voltage is cancelled at the output for particular angles. Hence, it is called **Voltage Cancellation Method**.

➤ The amplitude of the fundamental component at the output and its harmonics are again obtained by Fourier Analysis as:

$$\hat{V}_{oh} = \frac{2}{\pi} \int_{-\frac{\pi}{2}}^{\frac{\pi}{2}} v_o \cos(h\omega t) d\omega t$$

$$\hat{V}_{oh} = \frac{2}{\pi} \int_{-\beta}^{\beta} V_{DC} \cos(h\omega t) d\omega t$$

Evaluating the integral and simplifying yields:

$$\hat{V}_{oh} = \frac{4}{h\pi} V_{DC} \sin(h\beta)$$

where  $\beta = 90 - \frac{\alpha}{2}$  and  $h$  is also an odd integer!

➤ Setting  $\alpha = 60^\circ$  removes the third harmonic component and multiples of it (no Triplen harmonics).

➤ The minimum Total Harmonic Distortion (THD) is achieved with selecting  $\alpha$  to be slightly less than  $60^\circ$  ( $\sim 55^\circ$ ); as illustrated in the Figure next, noting that the Y-axis is normalized.

➤ Remember that the Total Harmonic Distortion (THD) is the ratio of the harmonic contents to the value of the fundamental component, and is given by:

$$THD = \frac{1}{\hat{V}_{o1}} \sqrt{\sum_{h=3}^{\infty} \hat{V}_{oh}^2} \times 100\%$$

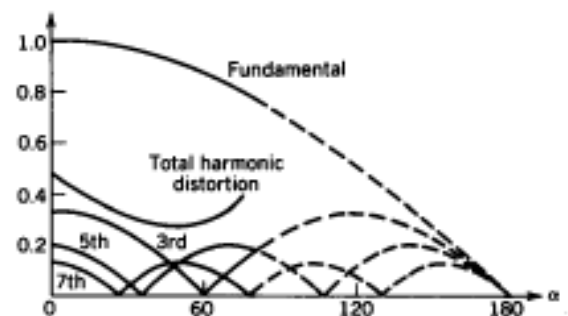
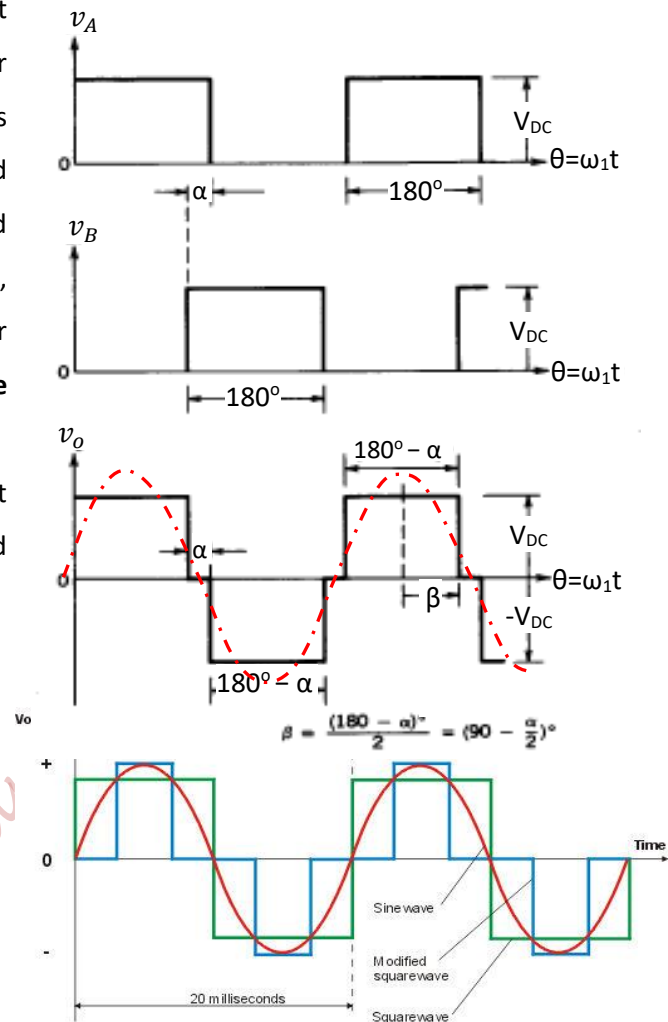

- ▶ The degree of adjustment of the fundamental component amplitude is limited by the rise in Total Harmonic Distortion as  $\alpha$  exceeds  $55^\circ$ .
- ▶ Filtering is required if the load cannot tolerate the harmonic currents.

## 1.2) Half Bridge (an Inverter Leg)

- ▶ One leg of the Full Bridge can be replaced, for AC operation only, by two large and equal capacitances.
- ▶ The inverter leg configuration is shown in the Figure next.
- ▶ The capacitances can be very expensive unless the output frequency is very high.
- ▶ Regardless of the switches' states, the current divides equally between the two capacitors;  $C_+$  and  $C_-$ .
- ▶ The midpoint between the two capacitors stays at the same potential;  $\frac{V_{DC}}{2}$ .
- ▶ The voltage across the load is half the value obtained from the single-phase VSI (Full Bridge) and is given by:

$$\hat{V}_{o1} = \frac{4 V_{DC}}{\pi \cdot 2} = 0.637 V_{DC}$$

and the harmonics are:

$$\hat{V}_{oh} = \frac{4 V_{DC}}{h\pi \cdot 2} = \frac{1}{h} 0.637 V_{DC}$$

Also,  $h$  is an odd integer.

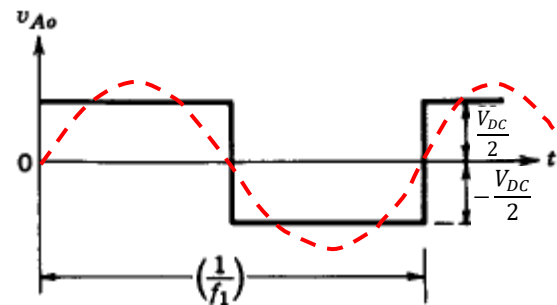
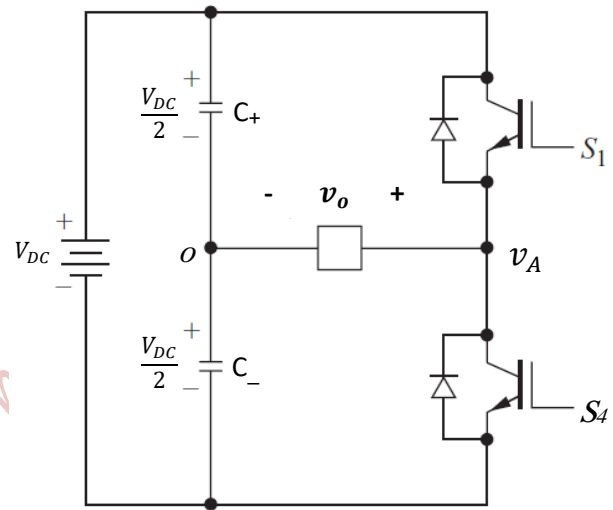

- ▶ The Frequency Spectrum of the output is illustrated in the Figure below.

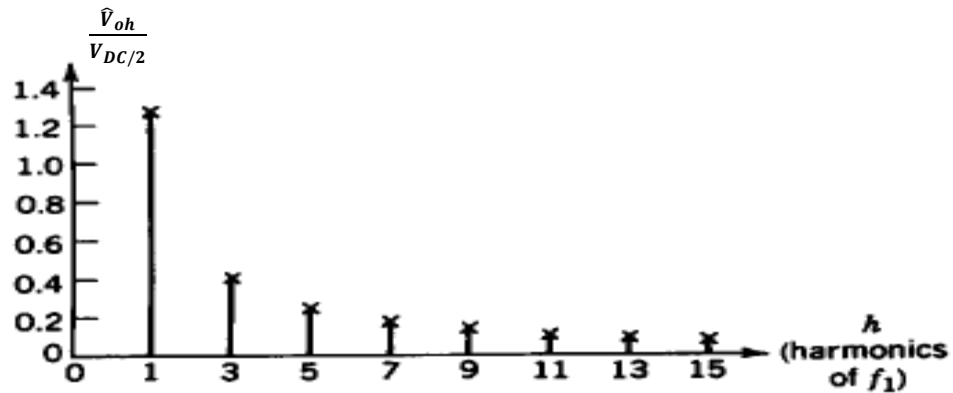

### 1.3) Three-Phase Voltage Source Inverters in Square Wave Mode

- ▶ Three Half Bridge Legs can be connected in parallel, as illustrated in the Figure below, to generate three-phase output voltages.

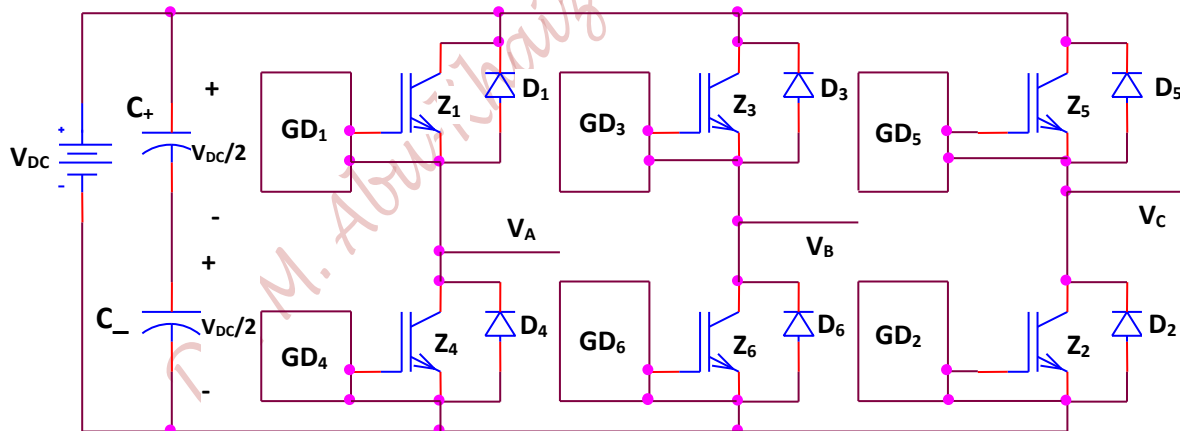

- ▶ The numbering sequence is the same as the conventional numbering sequence.
- ▶ Each IGBT has an anti-parallel diode.

➤ The voltage waveforms for 180° conduction in each switch for a Square Wave Operation are shown in the Figure below.

➤ The gate-emitter voltages of the switches are phase shifted by  $\frac{\pi}{3}$  (or 60°) for any two consequent switches.

➤ In the same leg, the gate signals of the switches are complements of each other (180° out of phase).

➤ In the same inverter level, upper or lower, the gate signals of the switches are shifted by  $\frac{2\pi}{3}$  (or 120°) for consequent switches in the sequence 1-3-5-1..., or in the sequence 2-4-6-2...

➤ The harmonic components' amplitude of the line-to-line voltage is obtained by Fourier Analysis as:

$$\hat{V}_{LLh} = \frac{4}{h\pi} V_{DC} \sin h\left(90 - \frac{\alpha}{2}\right)$$

where  $\alpha$ , in this case, is 60°

➤ The fundamental component's amplitude of the line-to-line voltage is:

$$\hat{V}_{LL1} = \frac{4}{(1)\pi} V_{DC} \sin(1) \left(90 - \frac{60}{2}\right)$$

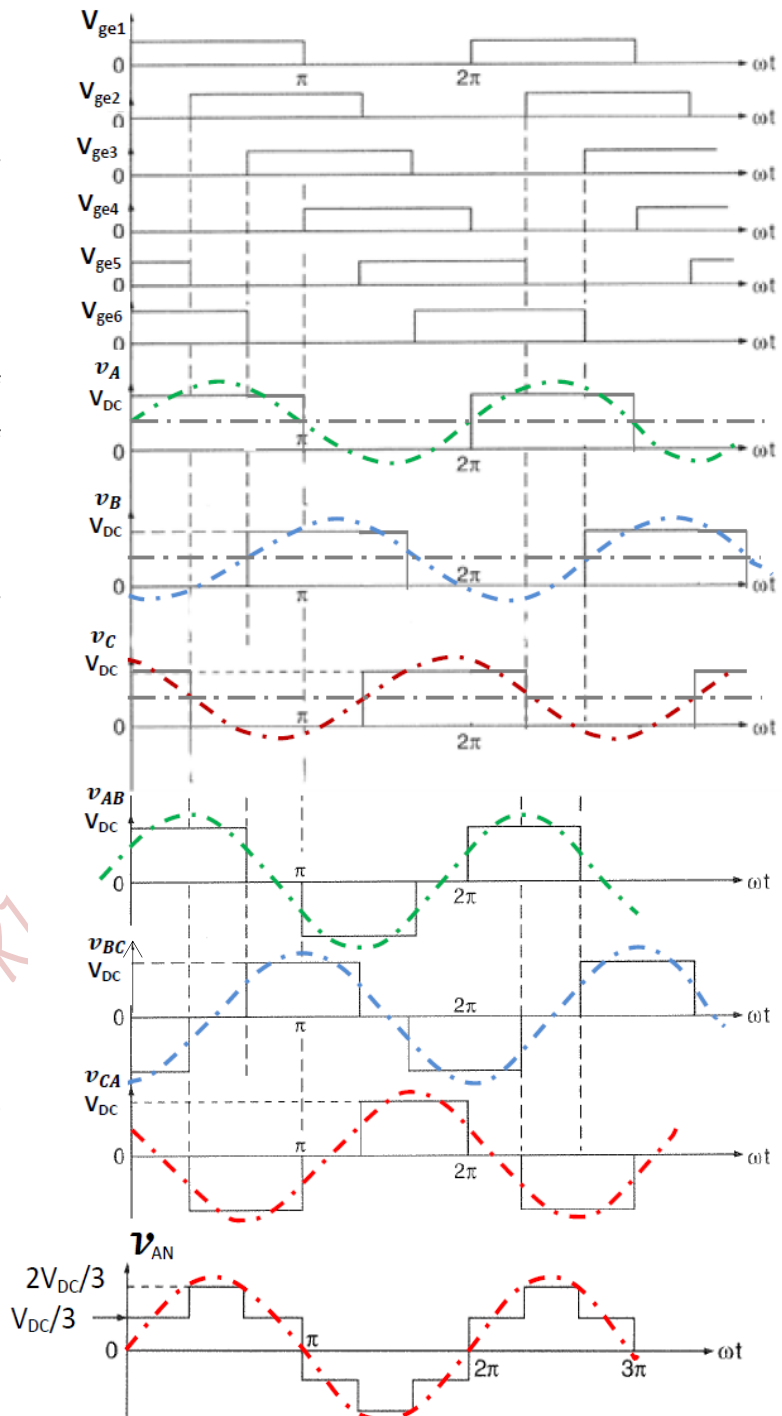



$$\Rightarrow \hat{V}_{LL1} = \frac{4}{\pi} V_{DC} \sin(60)$$

$$\hat{V}_{LL1} = \frac{4}{\pi} V_{DC} \frac{\sqrt{3}}{2}$$

which can be rewritten as:

$$\hat{V}_{LL1} = \sqrt{3} \left( \frac{4}{\pi} \frac{V_{DC}}{2} \right)$$

i.e. the peak of the line-to-line voltage is  $\sqrt{3}$  times the peak of the phase voltage!

$$\therefore \hat{V}_{LL1} = 1.103 V_{DC}$$

► The rms value of the line-to-line voltage is then:

$$V_{LL1} = 0.78 V_{DC}$$

► Note that the line-to-line voltage leads the respective phase voltage by  $\frac{\pi}{6}$  (or  $30^\circ$ ).

► Clearly, balanced three-phase voltages result!

► The Line to Neutral voltage can be derived for a Y-connected resistive load, by deriving the equivalent circuit during each switching mode, which is  $60^\circ$ . Mode 1 represents the period:  $0^\circ < \omega t < 60^\circ$ , Mode 2 represents the period:  $60^\circ < \omega t < 120^\circ$ , whilst Mode 6 represents the period:  $300^\circ < \omega t < 360^\circ$ . The equivalent circuits during these modes are shown in the Figure below. Other modes for other periods can be derived.

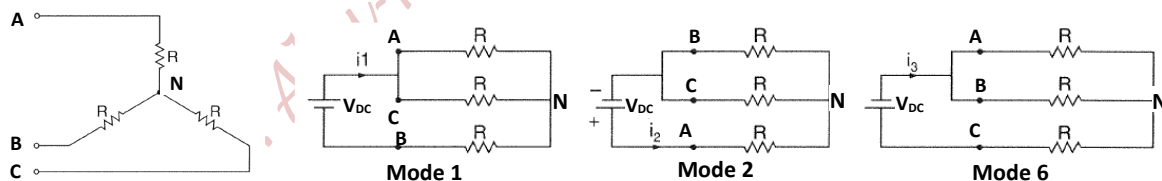

## Harmonics in the Output of a Three-Phase VSI with Square Wave Operation

The harmonics in the line-to-line voltage have amplitudes represented by the following formula:

$$\hat{V}_{LLh} = \frac{\sqrt{3}}{h} \left( \frac{4}{\pi} \frac{V_{DC}}{2} \right)$$

The harmonics die as  $\frac{1}{h}$ , where  $h = 6m \mp 1$ ; such that  $m = 1, 2, 3, 4, \dots$

The Frequency Spectrum of the line-to-line voltages output of a three-phase VSI in a **Square Wave Mode** is:

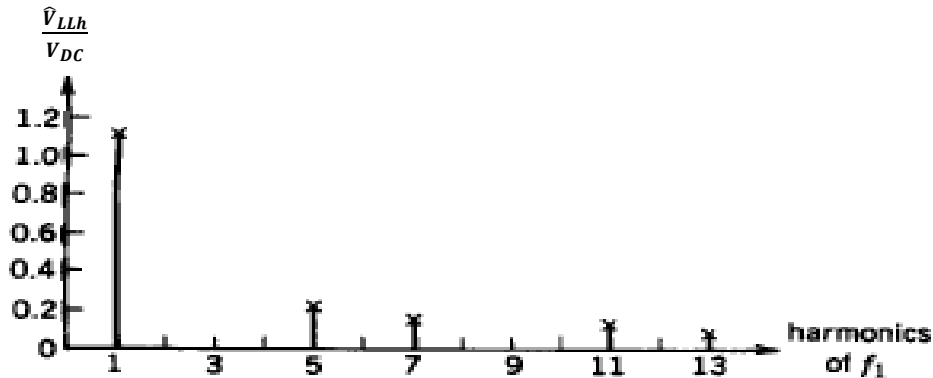

For a three-Phase VSI in a Square Wave Mode, it is not possible to control the output voltage magnitude by voltage cancellation via the inverter, as  $\alpha$  is fixed here to be  $60^\circ$ .

### General Comments:

- ☐ The use of Half, Full, or Three-Phase Bridges to generate an AC in the 'Square Wave' Mode is simple, but the harmonic content of the output is high.
- ☐ For some applications at high frequencies,  $> 20kHz$ , such as switch mode power supplies, and radio frequency heating, the square wave is acceptable or the load can be tuned to minimize the harmonic currents.
- ☐ For AC Motor Drives, operating at around 50Hz, filtering components are very bulky and expensive. In addition, harmonic currents may cause torque pulsation and vibrations, and severe losses and require derating of the machine. In these systems, Pulse Width Modulation (PWM) schemes are adopted to produce an output which is more closely sinusoidal.

## 2) Sinusoidal Pulse Width Modulation in Voltage Source Inverters

### (Switch Mode DC to AC Sinusoidal AC Inverters)

Many applications, notably AC Motor Drives, require an AC source, which has a lower harmonic content than that can be obtained by a simple Square Wave operation of the inverter. An effective solution is to use Sinusoidal Pulse Width Modulation (SPWM).

It was shown earlier that, the average output voltage of a Full Bridge can be made proportional to a control voltage ( $v_c$ ). The control voltage can be made sinusoidal to produce a sinusoidal output, within limits imposed by the switching frequency of the Bridge.

### 2.1) Sinusoidal Pulse Width Modulation in a Half Bridge

Consider one leg of a Full Bridge, shown in the Figure next, which is sensible for AC operation!

The transistors numbering is as before. It could be part of single-phase or three-phase Bridges.

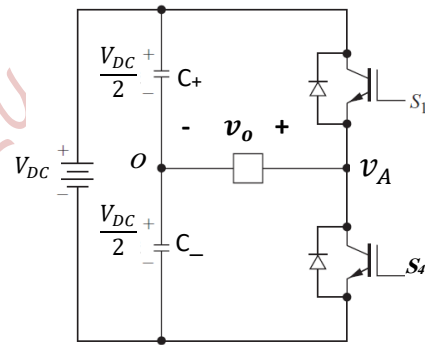

### Switching Waveforms

The control voltage ( $v_c$ ) is sinusoidal and must be at a lower frequency than that of the triangular voltage ( $v_{tri}$ ).

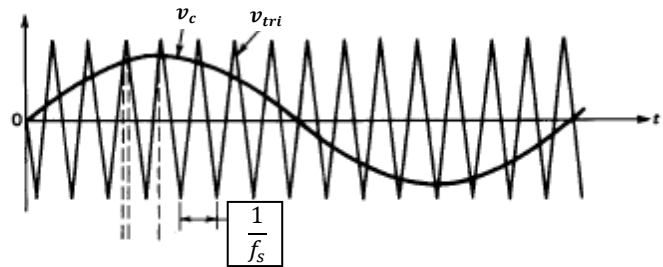

when  $v_c > v_{tri}$ :

$$Z_1 \text{ is on and } Z_4 \text{ is off} \Rightarrow v_{AO} = \frac{V_{DC}}{2}$$

when  $v_c < v_{tri}$ :

$$Z_1 \text{ is off and } Z_4 \text{ is on} \Rightarrow v_{AO} = -\frac{V_{DC}}{2}$$

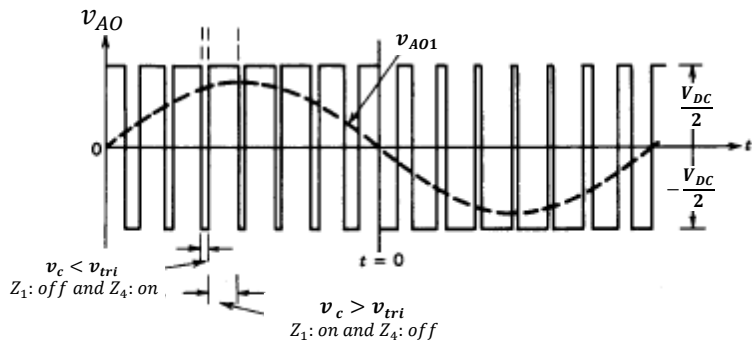

- The triangular signal ( $v_{tri}$ ) is maintained at a constant amplitude ( $\hat{V}_{tri}$ ), and its frequency ( $f_s$ ) is called the switching frequency or carrier frequency.
- The control voltage ( $v_c$ ) modulates the duty cycle of the switches and has a variable frequency ( $f_1$ ) and a variable magnitude.
- The fundamental frequency of the inverter output is, therefore,  $f_1$ .
- The inverter output will contain harmonics related to  $f_1$  and  $f_s$ .
- The Amplitude Modulation Index or Ratio (M) is defined as:

$$M = \frac{\hat{V}_c}{\hat{V}_{tri}}$$

where  $\hat{V}_c$  is the amplitude of the control voltage.

- The Frequency Modulation Ratio ( $m_f$ ) is defined as:

$$m_f = \frac{\text{Switching frequency}}{\text{Modulating frequency}} = \frac{f_s}{f_1}$$

- The inverter leg is controlled according to the scheme:

$$\text{when } v_c > v_{tri}, Z_1 \text{ is 'on' and } Z_4 \text{ is 'off'} \Rightarrow v_{AO} = \frac{V_{DC}}{2}$$

$$\text{when } v_c < v_{tri}, Z_1 \text{ is 'off' and } Z_4 \text{ is 'on'} \Rightarrow v_{AO} = -\frac{V_{DC}}{2}$$

- Note that, a Dead time between switches is always needed in VSI legs!!

**For  $M \leq 1$  and a Half Bridge, the following apply:**

1. The output voltage is:

$$v_{AO}(t) = M \frac{V_{DC}}{2} \sin \omega_1 t + \text{Harmonics}$$

2. The amplitude of the fundamental component is:

$$\hat{V}_{AO1} = M \frac{V_{DC}}{2}$$

3. The harmonics in the output are centered around (at the side bands of) the switching frequency,  $f_s$ , and its multiples, and they are related by:

$$f_h = (n m_f \mp k) f_1$$

where  $n$  and  $k$  are integers. However, for odd values of  $n$ , the harmonics exist only for even values of  $k$ , and vice versa. For example,

$$1m_f \mp \text{even}: 1m_f \mp 0, 1m_f \mp 2, 1m_f \mp 4, 1m_f \mp 6, 1m_f \mp 8, \dots$$

$$2m_f \mp \text{odd}: 2m_f \mp 1, 2m_f \mp 3, 2m_f \mp 5, 2m_f \mp 7, \dots$$

4. Adopting an **odd integer for  $m_f$  in a Half Bridge** results in only odd harmonics of  $m_f$  in the Frequency Spectrum (a result from signal analysis by Fourier). Note that the Frequency Modulation Ratio ( $m_f$ ) for the previous waveforms is 15.
5. The Frequency Spectrum of the previous output voltage at  $M = 0.8$  and  $m_f = 15$  is shown in the Figure below. Note that there is no harmonic component at  $2m_f$ , because  $m_f$  was selected to have an odd value.

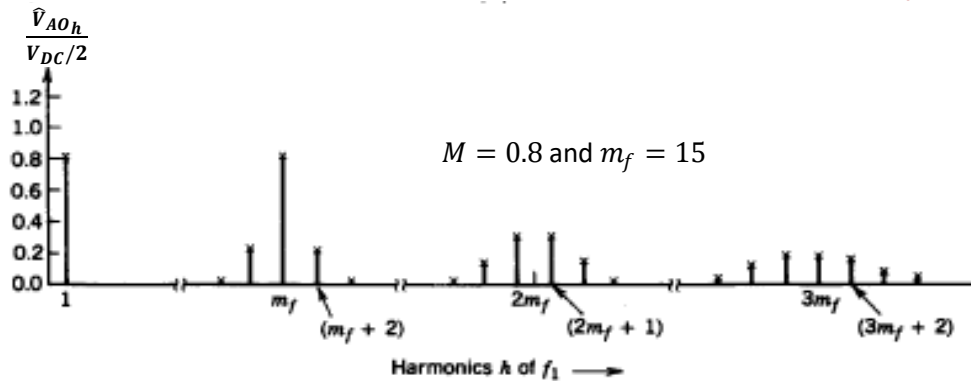

6. The amplitudes of the fundamental component and harmonics are obtained from tables. An example of these tables is shown below, which depicts the values of the fundamental component and the harmonics at the output of Half and Full Bridges for  $m_f \geq 9$ .

| $M \backslash h$   | 0.2   | 0.4   | 0.6   | 0.8   | 1.0   |
|--------------------|-------|-------|-------|-------|-------|
| 1                  | 0.2   | 0.4   | 0.6   | 0.8   | 1.0   |
| <b>Fundamental</b> |       |       |       |       |       |
| $m_f$              | 1.242 | 1.15  | 1.006 | 0.818 | 0.601 |
| $m_f \pm 2$        | 0.016 | 0.061 | 0.131 | 0.220 | 0.318 |
| $m_f \pm 4$        |       |       |       |       | 0.018 |
| $2m_f \pm 1$       | 0.190 | 0.326 | 0.370 | 0.314 | 0.181 |
| $2m_f \pm 3$       |       | 0.024 | 0.071 | 0.139 | 0.212 |
| $2m_f \pm 5$       |       |       |       | 0.013 | 0.033 |
| $3m_f$             | 0.335 | 0.123 | 0.083 | 0.171 | 0.113 |
| $3m_f \pm 2$       | 0.044 | 0.139 | 0.203 | 0.176 | 0.062 |
| $3m_f \pm 4$       |       | 0.012 | 0.047 | 0.104 | 0.157 |
| $3m_f \pm 6$       |       |       |       | 0.016 | 0.044 |
| $4m_f \pm 1$       | 0.163 | 0.157 | 0.008 | 0.105 | 0.068 |
| $4m_f \pm 3$       | 0.012 | 0.070 | 0.132 | 0.115 | 0.009 |
| $4m_f \pm 5$       |       |       | 0.034 | 0.084 | 0.119 |
| $4m_f \pm 7$       |       |       |       | 0.017 | 0.050 |

## Factors Influencing the Choice of the Switching Frequency:

In general, a higher switching frequency makes the filtering of harmonics easier, but increases the switching losses in the inverter. Besides, it is very advantageous to have the switching frequency above  $20\text{kHz}$  so that it is inaudible; i.e. **audible converter noise against switching losses**.

A second, more subtle, choice is the **adoption of an odd integer for  $m_f$ , in a Half Bridge**, so that there is both odd symmetry and half wave symmetry. As a result, **cosines and even harmonics disappear** from the Fourier series.

### I) Small $m_f$ ( $m_f \leq 21$ )

In some machine applications, a need for an output frequency up to  $200\text{Hz}$  and a switching frequency say  $2\text{kHz}$  result in a low  $m_f$ . The **modulating frequency ( $f_1$ ) and the switching frequency ( $f_s$ ) should be synchronized** ( $m_f$  should be integer) to avoid beating and appearance of subharmonics. Beating may occur if  $f_s$  is close to  $f_1$  (the harmonics may be amplified depending on the output filter characteristics), which is a problem in Thyristor inverters.

### II) Large $m_f$ ( $m_f > 21$ )

Synchronization of  $f_s$  and  $f_1$  is not so important, as the amplitudes of the beat frequency components are less. Nevertheless, **synchronization is advisable with inverters supplying AC machines. Synchronization means that selecting  $m_f$  to be an integer.**

## Over Modulation ( $M > 1$ )

For  $M \leq 1$ , the amplitude of the fundamental component at the output is proportional to the amplitude of the control voltage, and the harmonics are pushed up to around the switching frequency.

However, a greater output can be obtained at the cost of increased harmonic content by making  $M > 1$ . Ultimately, a Square Wave Mode results!

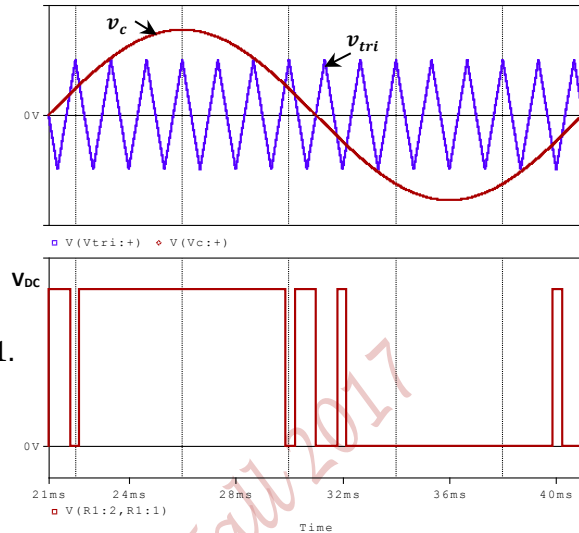

The relation between the output voltage and a wide range of Modulation Index is illustrated in the Figure next. There are three distinctive regions: a Linear region ( $M \leq 1$ ), an Over Modulation region ( $1 < M < 3.24$ ), and a Square Wave region ( $M > 3.24$ ).

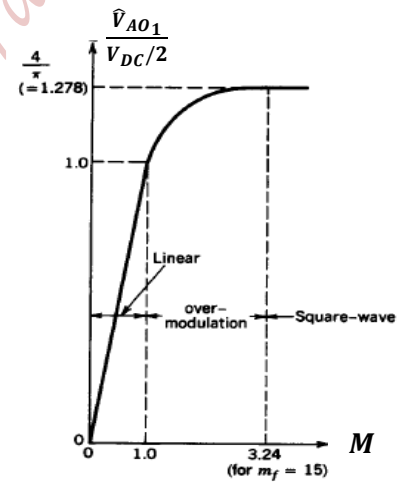

There are trade-offs; a Square Wave mode gives a higher output, but more harmonics.

The Frequency Spectrum of the output at  $M = 2.5$  and  $m_f = 15$  is shown in the Figure below.

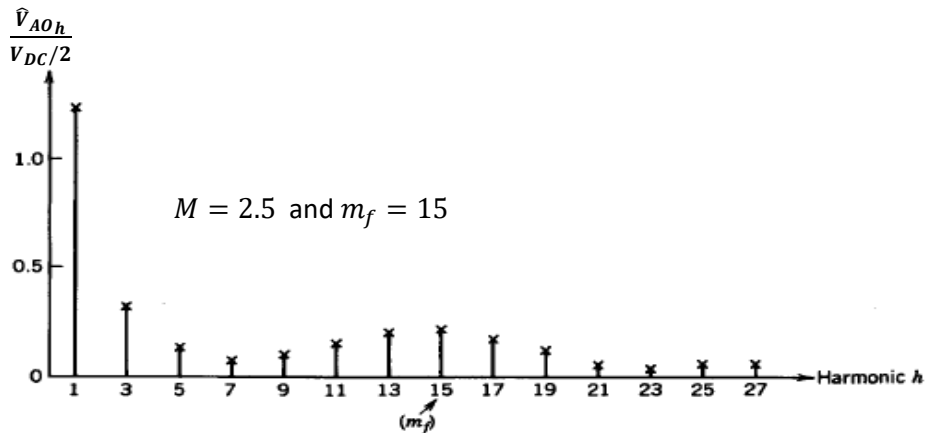

## 2.2) Sinusoidal Pulse Width Modulation in a Single-Phase Voltage Source Inverter

The Sinusoidal Pulse Width Modulation (SPWM) scheme can be realized in a Full bridge using either Bipolar or Unipolar Switching Strategies.

### 2.2.1) Bipolar Switching Strategy

As illustrated before, a Bipolar switching strategy treats every two switches as a pair;  $Z_1$  &  $Z_2$  is a pair, and  $Z_3$  &  $Z_4$  is the second pair. The switches in each pair are switched together, simultaneously.

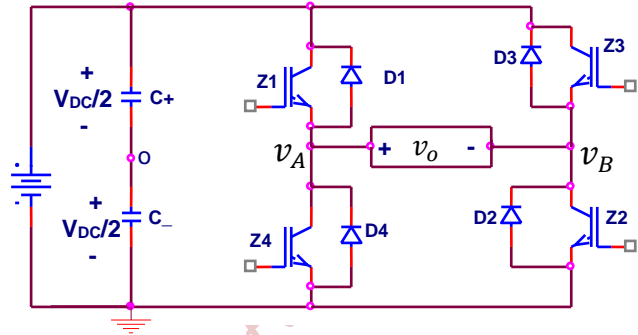

Therefore, one control voltage ( $v_c$ ) is compared with a triangular signal ( $v_{tri}$ ) to produce the gate signals of the switches pairs, which are complement to each other.

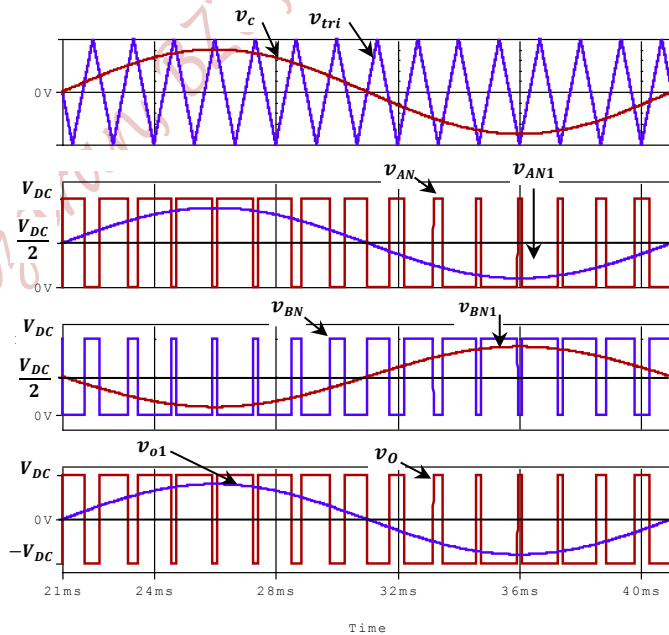

$v_{AN}$  and  $v_{BN}$  are the voltages at the midpoints of Leg A and Leg B with respect to the negative terminal of the supply, respectively.

The output of each leg with respect to  $\frac{V_{DC}}{2}$  is the same as that of a Half Bridge, but they are shifted from each other by  $180^\circ$ .

For bipolar switching, the output is given by:

$$v_o = v_{AN} - v_{BN}$$



The output voltage for  $M \leq 1$  is:

$$v_o(t) = M \frac{V_{DC}}{2} \sin \omega_1 t - M \frac{V_{DC}}{2} \sin(\omega_1 t - 180^\circ) + \text{Harmonics}$$

$$v_o(t) = M \frac{V_{DC}}{2} \sin \omega_1 t + M \frac{V_{DC}}{2} \sin \omega_1 t + \text{Harmonics}$$

$$v_o(t) = 2M \frac{V_{DC}}{2} \sin \omega_1 t + \text{Harmonics}$$

$$\mathbf{v_o(t) = MV_{DC} \sin \omega_1 t + \text{Harmonics}}$$

- The dotted/dashed curves represent the fundamental component for the respective voltage.
- The harmonics in the output are similar to those found in the output of one leg. The harmonics are, also, centered around (at the side bands of) the switching frequency,  $f_s$ , and its multiples, and they are related by:

$$f_h = (n m_f \mp k) f_1$$

where  $n$  and  $k$  are integers. However, for odd values of  $n$ , the harmonics exist only for even values of  $k$ , and vice versa.

- $m_f$  is selected to be an **odd integer for Bipolar Switching Strategy** in a Full Bridge.
- The Frequency Spectrum of the output voltage, for example, at  $M = 0.8$  and  $m_f = 15$  is shown in the Figure below.

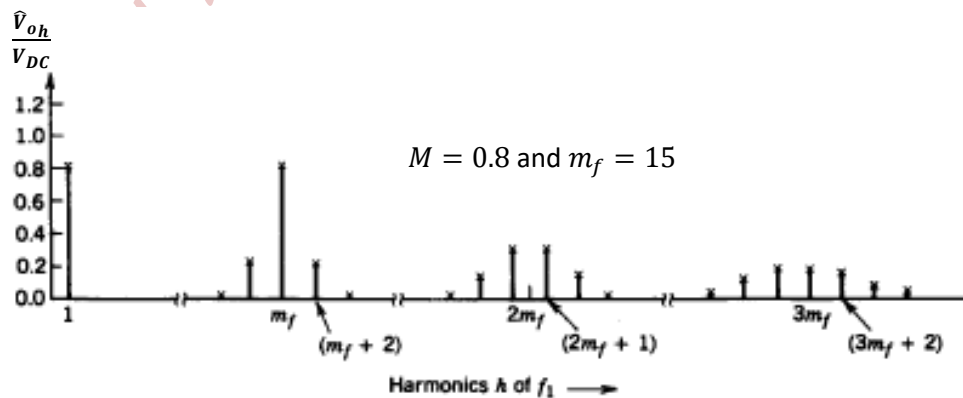

## 2.2.2) Unipolar Switching Strategy

It was noted earlier, in the DC-DC Converter, that the Unipolar switching doubles the effective switching frequency at the output without increasing the switching losses in the inverter. It is also an attractive feature in single phase inverters.

Each inverter Leg is controlled by its own control voltage, independent from the other. Hence, two control voltages ( $v_c$  and  $-v_c$ ) are needed.

The control voltages are sinusoidals, and have the same magnitude, but they are  $180^\circ$  out of phase.

$v_c$  controls the switches in Leg A, whilst  $-v_c$  controls the switches in Leg B.

The control voltages are compared with the same triangular voltage ( $v_{tri}$ ).

The Unipolar strategy is implemented according to the following:

- **when  $v_c > v_{tri} \Rightarrow Z_1$  is turned 'on' and  $Z_4$  is turned 'off'**  
Leg's A voltage with respect to the supply negative terminal is  $v_{AN} = V_{DC}$
- **when  $v_c < v_{tri} \Rightarrow Z_1$  is turned 'off' and  $Z_4$  is turned 'on'**  
Leg's A voltage with respect to the supply negative terminal is  $v_{AN} = 0$
- **when  $-v_c > v_{tri} \Rightarrow Z_3$  is turned 'on' and  $Z_2$  is turned 'off'**  
Leg's B voltage with respect to the supply negative terminal is  $v_{BN} = V_{DC}$
- **when  $-v_c < v_{tri} \Rightarrow Z_3$  is turned 'off' and  $Z_2$  is turned 'on'**  
Leg's B voltage with respect to the supply negative terminal is  $v_{BN} = 0$

The output voltage is:

$$v_o = v_{AN} - v_{BN}$$

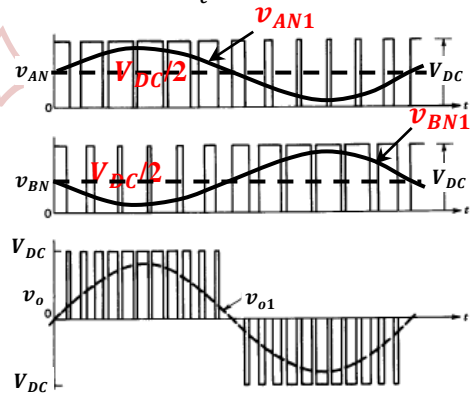
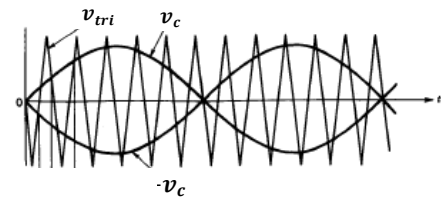
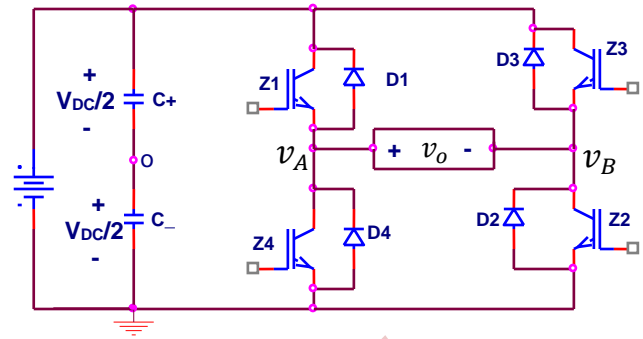

- For  $M \leq 1$ , the output voltage, again, is:

$$v_o(t) = MV_{DC} \sin \omega_1 t + \text{Harmonics}$$

- The effective doubling of the switching frequency at the output in the Unipolar scheme shifts the harmonics up in frequency. The harmonics have frequencies represented by the following equation:

$$f_h = (n 2m_f \mp k) f_1$$

where  $n$  and  $k$  are again integers. But, since the coefficient of  $m_f$  is " $2n$ ", which is always even,  $k$  takes odd values only!

- Compared with the Bipolar strategy, filtering is easier with Unipolar, as harmonics are at higher frequencies for the same inverter switching losses.
- $m_f$  is selected to be an **even integer for Unipolar Switching Strategy**, to eliminate particular harmonics off the spectrum. The phase difference between harmonics in  $v_{AN}$  and  $v_{BN}$  is  $180^\circ m_f$ , so if  $m_f$  was selected to be even, some of these harmonics would be in phase and would cancel each other.
- The Frequency Spectrum of the output voltage, for example, at  $M = 0.8$  and  $m_f = 12$  is shown in the Figure below.

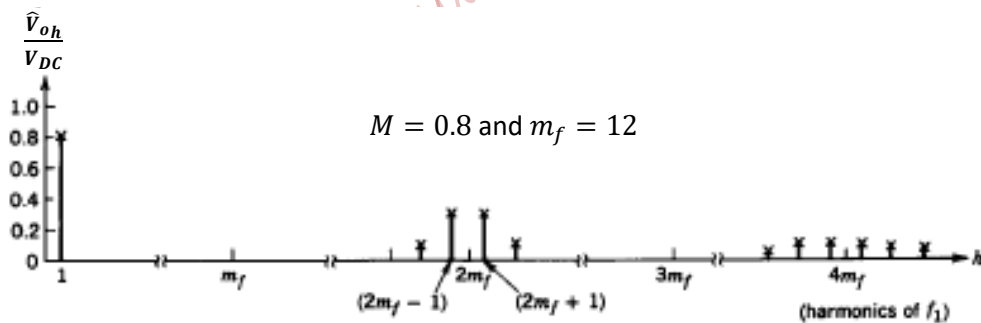

### 2.3) Sinusoidal Pulse Width Modulation in a Three-Phase Voltage Source Inverter

The three-phase Bridge (Inverter) can also be used with Sinusoidal Pulse Width Modulation (SPWM).

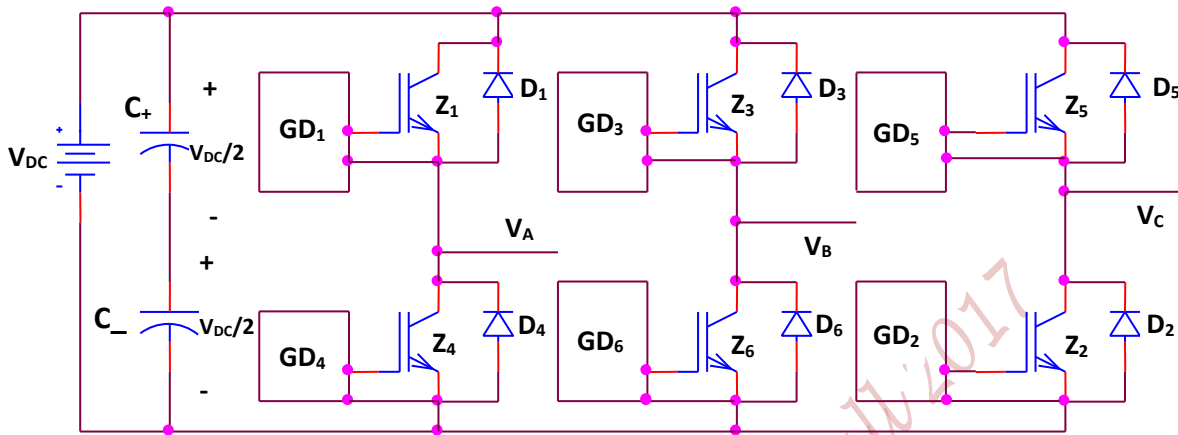

Three control voltages ( $v_{cont A}$ ,  $v_{cont B}$ , and  $v_{cont C}$ ), which are  $120^\circ$  out of phase from each other, are compared with a common triangular voltage ( $v_{tri}$ ) to produce the gate signals for each switch (IGBT) in the respective leg.

SPWM generation can be achieved either by:

1. Microcontroller/Microprocessors
2. Chips; for example **MA828**

The control strategy is implemented according to the following:

- when  $v_{cont A} > v_{tri} \Rightarrow Z_1$  is turned 'on' and  $Z_4$  is turned 'off'  
Leg's A voltage with respect to the supply negative terminal is  $v_{AN} = V_{DC}$
- when  $v_{cont A} < v_{tri} \Rightarrow Z_1$  is turned 'off' and  $Z_4$  is turned 'on'  
Leg's A voltage with respect to the supply negative terminal is  $v_{AN} = 0$
- when  $v_{cont B} > v_{tri} \Rightarrow Z_3$  is turned 'on' and  $Z_6$  is turned 'off'  
Leg's B voltage with respect to the supply negative terminal is  $v_{BN} = V_{DC}$
- when  $v_{cont B} < v_{tri} \Rightarrow Z_3$  is turned 'off' and  $Z_6$  is turned 'on'  
Leg's B voltage with respect to the supply negative terminal is  $v_{BN} = 0$
- when  $v_{cont C} > v_{tri} \Rightarrow Z_5$  is turned 'on' and  $Z_2$  is turned 'off'  
Leg's C voltage with respect to the supply negative terminal is  $v_{CN} = V_{DC}$
- when  $v_{cont C} < v_{tri} \Rightarrow Z_5$  is turned 'off' and  $Z_2$  is turned 'on'  
Leg's C voltage with respect to the supply negative terminal is  $v_{CN} = 0$

The switching waveforms are shown in the Figure next.

Note that the fundamental line-to-line voltage ( $v_{AB1}$ ) leads  $v_{AN1}$  by  $30^\circ$ , which is consistent with three-phase concept.

For  $0 \leq M \leq 1$ , the fundamental component of one leg, for example Leg A, has an amplitude of:

$$\hat{V}_{AN1} = M \frac{V_{DC}}{2}$$

Thus, the amplitude of the fundamental component of the line-to-line voltage is:

$$\hat{V}_{LL1} = \sqrt{3} M \frac{V_{DC}}{2}$$

$$\Rightarrow \hat{V}_{LL1} = 0.866 M V_{DC}$$

The rms value of the line-to-line voltage is:

$$V_{LL1rms} = \frac{\sqrt{3}}{\sqrt{2}} M \frac{V_{DC}}{2}$$

$$V_{LL1rms} = 0.612 M V_{DC}$$

Therefore, the output line-to-line voltage between phases 'A' and 'B' is:

$$v_{AB}(t) = 0.866 M V_{DC} \sin(\omega_1 t + \frac{\pi}{6}) + \text{Harmonics}$$

The comments for Over Modulation apply also for three-phase inverters.

The harmonic content of line-to-line voltage can be reduced by making  $m_f$  an odd integer and multiple of 3. This suppresses harmonics at  $m_f$  and  $3nm_f$ , where  $n$  is an integer. Because some of the harmonics in the phase voltages are phase shifted from each other by  $120^\circ m_f$ . Consequently, eliminating each other from the line-to-line voltages.

The Frequency Spectrum of the line-to-line voltage, for example, at  $M = 0.8$  and  $m_f = 15$  is shown in the Figure below.

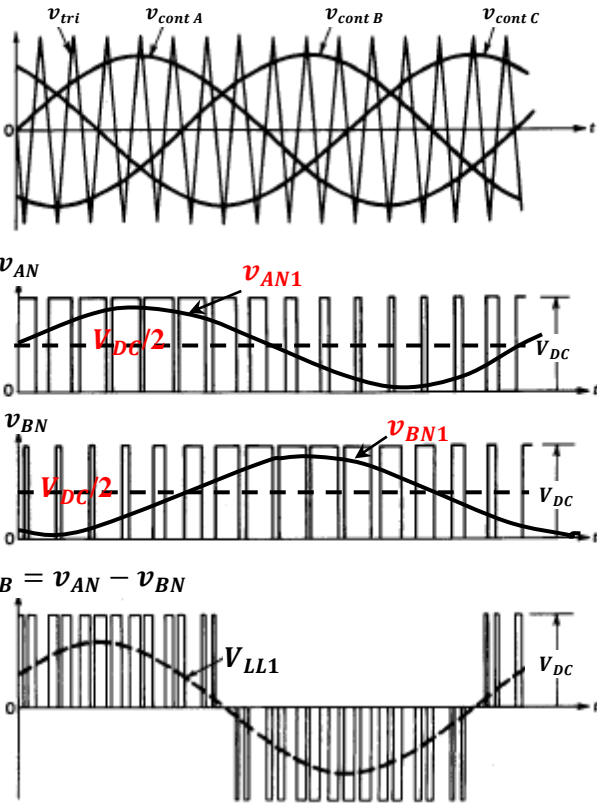
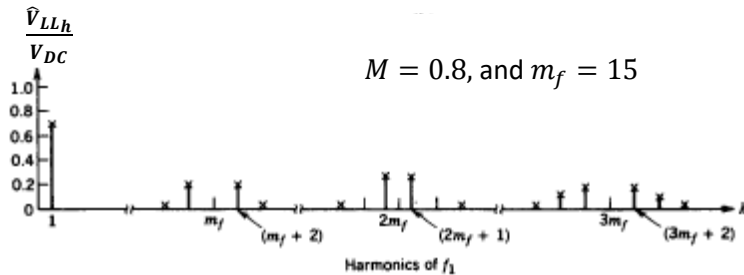

## Space Vector Modulation (SVM)

### Introduction

- The SVM is a method of generating a sequence of switching combinations of the inverter. Each combination is called a state.
- The Space Vector (SV) is a complex number that can be represented by any three quantities, not necessarily sinusoidal, which add up to zero (with the neutral being disconnected).
- These states can be represented in the complex plane by Space Vectors (SVs) and are of two types; zero and non-zero states.
- In a Current Source Inverter (CSI), a non-zero state allows the DC link current ( $I_{dc}$ ) to complete its path through the output load, whilst a zero state shorts one of the inverter legs and no current, from the DC bus, passes to the load ( $I_{dc}$  completes its path through one of the inverter legs). In a CSI, there are six non-zero and three zero states.
- In a Voltage Source Inverter (VSI), during non-zero states the DC link voltage is applied to the load, whilst no voltage is applied to the load during the zero states. Thus, in a VSI there are six non-zero and two zero states only.
- Therefore, more switching sequences are available in a CSI, because of the increased degrees of freedom in choosing the zero state.
- **Advantages of SVM over other PWM Techniques:**
  1. It is easier and more feasible for digital implementations and microprocessor control.
  2. It reduces the switching frequency of the inverter. For example, compared with an equivalent Sinusoidal PWM based system, the switching frequency will be reduced to approximately half the carrier frequency.
  3. A Modulation Index of 1.15 can be reached without any constraints. On the other hand, for Sinusoidal PWM, in the case of over-modulation, some pulses are dropped and low order harmonics appear at the output, which can be avoided by the addition of Triplen harmonic to the sinusoidal modulating waveforms.
  4. The AC Gain is higher in SVM. For a three-phase Inverter, the AC Gain is defined as:

$$G_{AC} = \frac{V_{LL1}}{V_{DC}} \Big|_{M=1}$$

The **AC Gain for SVM is 1, whilst it is 0.866 for SPWM.**

## Space Vector Modulation (SVM) in a Current Source Inverter

- ◆ The Space Vector (SV) is a complex number that can be represented by any three quantities, not necessarily sinusoidal, which add up to zero (with the neutral being disconnected).
- ◆ The topology of a Current Source Inverter (CSI) is shown in the Figure below.

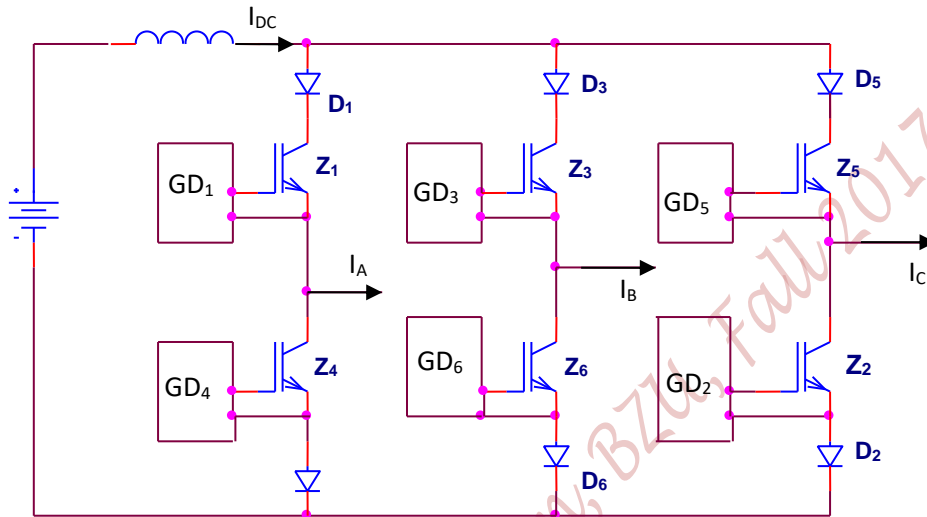

- ◆ The Space Vector Current ( $I_n$ ) associated with the AC line currents of a three-phase CSI can be generated by a proper selection of the SVs that represent the states.  $I_n$  is given by:

$$I_n = \frac{2}{3} (i_a + i_b * e^{j\frac{2\pi}{3}} + i_c * e^{-j\frac{2\pi}{3}}) = R + jI_m \quad (VI.1)$$

where  $i_a$ ,  $i_b$ , and  $i_c$  are the instantaneous magnitudes of the three-phase line currents, refer to Figure VI.1,  $R$  and  $I_m$  are the real and the imaginary components of  $I_n$ , respectively.

- ◆ Each state produces three-phase line currents, the magnitude of each is defined in Table VI.1. The table shows the nine-possible states for a CSI with the associated 'ON' switches, while the other switches are 'OFF', and the respective per unit line currents, with the DC link current ( $I_{dc}$ ) chosen as the base quantity.

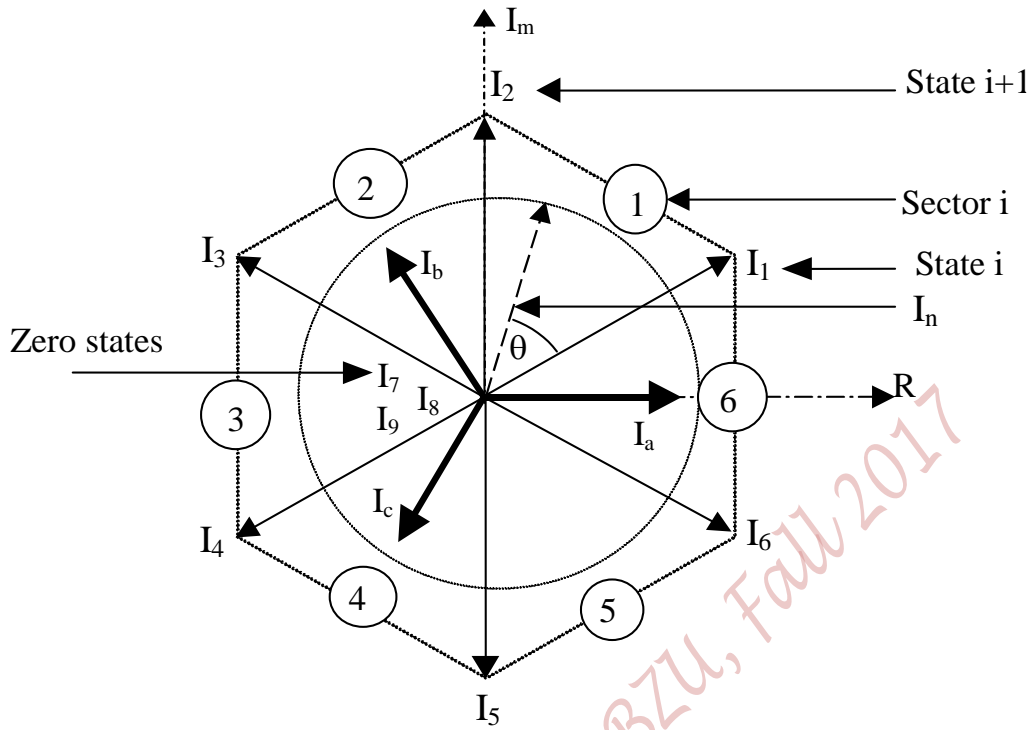

Figure VI.1: Representation of SVs (states) in the complex plane

Table VI.1: Possible states and their respective per-unit line currents in a CSI.

| State | 'ON' switches | $i_a / I_{dc}$ | $i_b / I_{dc}$ | $i_c / I_{dc}$ |
|-------|---------------|----------------|----------------|----------------|
| $I_1$ | $Z_1, Z_2$    | 1              | 0              | -1             |
| $I_2$ | $Z_2, Z_3$    | 0              | 1              | -1             |
| $I_3$ | $Z_3, Z_4$    | -1             | 1              | 0              |
| $I_4$ | $Z_4, Z_5$    | -1             | 0              | 1              |
| $I_5$ | $Z_5, Z_6$    | 0              | -1             | 1              |
| $I_6$ | $Z_6, Z_1$    | 1              | -1             | 0              |
| $I_7$ | $Z_1, Z_4$    | 0              | 0              | 0              |
| $I_8$ | $Z_3, Z_6$    | 0              | 0              | 0              |
| $I_9$ | $Z_5, Z_2$    | 0              | 0              | 0              |

Figure VI.1 shows the SVs representing the states, the line currents, and  $I_n$  in the complex plane.  $I_n$  is represented by an equivalent SV, having a magnitude and an angular position  $\theta$  depending on the state SVs representing it. The objective of SVM technique is to approximate  $I_n$  with the nine SVs ( $I_k, k=1...9$ ) available in the CSI. So that it will have an amplitude proportional to the Modulation Index (M), and rotating in the complex plane with an angular velocity ( $\omega$ ) proportional to the frequency of the fundamental output current



( $f_1$ ). By approximating  $I_n$  using the nearest two non-zero SVs, ( $I_i$  and  $I_{i+1}$ ), and one zero SV, ( $I_z = I_7, I_8$  or  $I_9$ ), the AC Gain of the technique is maximized and the switching frequency is minimized, as seen in Table VI.2.

**The AC Gain ( $G_{AC}$ )** is defined as the maximum value of the fundamental component of the line-to-line voltage to the amplitude of the unfiltered pulses comprising the same component (the DC value).

Thus, if the Space Vector Current ( $I_n$ ) is lying between the arbitrary space vectors  $I_i$  and  $I_{i+1}$ , the following expressions can be derived:

$$I_n * t_{cycle} = I_i * t_i + I_{i+1} * t_{i+1} + I_z * t_z \quad (VI.2)$$

where  $t_{cycle}$  is the period of one carrier cycle ( $t_{cycle} = 1/f_c$ ), while  $t_i$ ,  $t_{i+1}$ , and  $t_z$  are the times of state  $i$ ,  $i+1$  and zero-state (for  $M \leq 1$ ), respectively. Their values can be calculated using the following equations:

$$t_i = t_{cycle} * M * \sin((\pi/3) - \theta) \quad (VI.3)$$

$$t_{i+1} = t_{cycle} * M * \sin(\theta) \quad (VI.4)$$

$$t_z = t_{cycle} - t_i - t_{i+1} \quad (VI.5)$$

$$\theta = \omega_1 * t \quad (VI.6)$$

$$\omega_1 = 2 * \pi * f_1 \quad (VI.7)$$

Such that  $f_1 = 1/T$ , is the fundamental frequency at the output

The Space Vector Current ( $I_n$ ) can be moved in the complex plane by a step of:

$$\Delta\theta = \frac{360f_1}{f_c} \quad (VI.8)$$

## Selection of States

Within one sector, only three states are used to represent  $I_n$ . However, the sequence in which the states are used to control the inverter switches can be designed. Some of these sequences are known as Sequence 'A', Sequence 'B', and Sequence 'C', and are shown in Figure VI.2. Once the SV sequence is fixed, the selection of the zero SV defines the switching frequency, but the line current wave-shape does not depend upon the selected zero SV. Figure VI.3 shows the possible state transitions between states  $I_1$  to  $I_2$  in sector 1. Table VI.3 shows the zero SV ( $I_z$ ) to be used in each sector in order to minimise the switching frequency, and hence the switching losses.

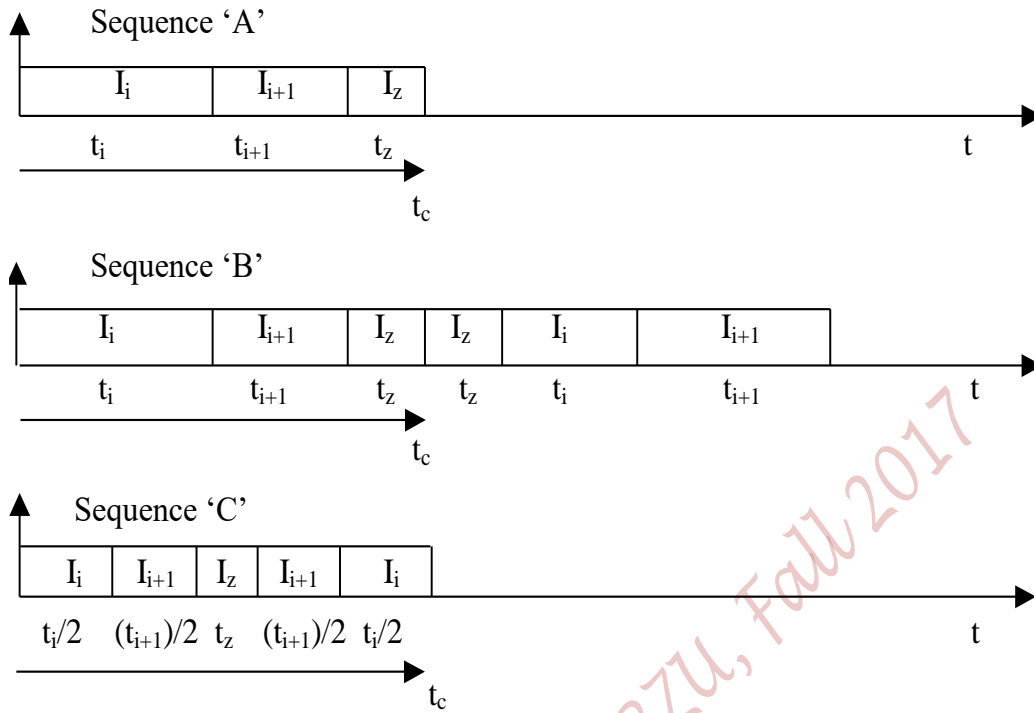

Figure VI.2: Possible sequences of SVs (states) in a CSI

Table VI.2: The switching sequence dictates the switching frequency and the AC Gain

| Technique                | Category | Switching frequency ( $f_{sw}$ ) | AC Gain ( $G_{AC}$ ) |
|--------------------------|----------|----------------------------------|----------------------|
| Sinusoidal PWM           | Analogue | $f_c$                            | 0.866                |
| Third Harmonic Injection | Analogue | $f_c$                            | 1                    |
| Trapezoidal PWM          | Analogue | $f_c$                            | 1.053                |
| Dead-band PWM            | Analogue | $2/3 * f_c - 1$                  | 1                    |
| Mod. Dead-band           | Analogue | $1/2 * (f_c + 1)$                | 1                    |
| SVM, Seq.'A'             | Digital  | $f_c/2$                          | 1                    |
| SVM, Seq.'B'             | Digital  | $5 * (f_c/12) - 1$               | 1                    |
| SVM, Seq.'C'             | Digital  | $(f_c/2) - 1$                    | 1                    |

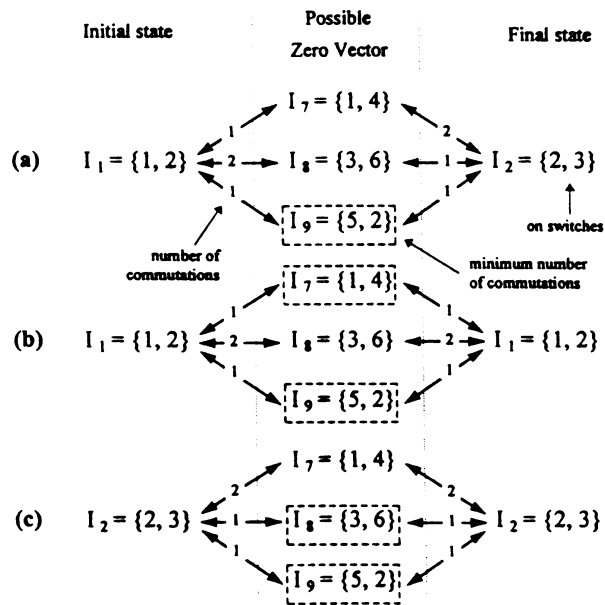

Figure VI.3: Possible state transitions in sector 1 involving a zero SV for a CSI

(a) Transition:  $I_1$  to  $I_2$  to  $I_2$  OR  $I_2$  to  $I_2$  to  $I_1$

(b) Transition:  $I_1$  to  $I_2$  to  $I_1$

(c) Transition:  $I_2$  to  $I_2$  to  $I_2$

Table VI.3: Sectors and respective zero states recommended for minimum switching frequency in a CSI.

| Sector <sub>i</sub> | $I_i$ | $I_{i+1}$ | $I_z$ |
|---------------------|-------|-----------|-------|
| 1                   | $I_1$ | $I_2$     | $I_9$ |
| 2                   | $I_2$ | $I_3$     | $I_8$ |
| 3                   | $I_3$ | $I_4$     | $I_7$ |
| 4                   | $I_4$ | $I_5$     | $I_9$ |
| 5                   | $I_5$ | $I_6$     | $I_8$ |
| 6                   | $I_6$ | $I_1$     | $I_7$ |

## SVM and Sinusoidal PWM Waveforms in a CSI

For  $M = 0.7$  and  $f_c = 900\text{Hz}$ , the gate signals obtained by SVM for a VSI are shown in Figure VI.4. On the other hand, Figure VI.5 shows the comparative sinusoidal PWM gate signals. It is clear that the number of switching transitions is minimized.

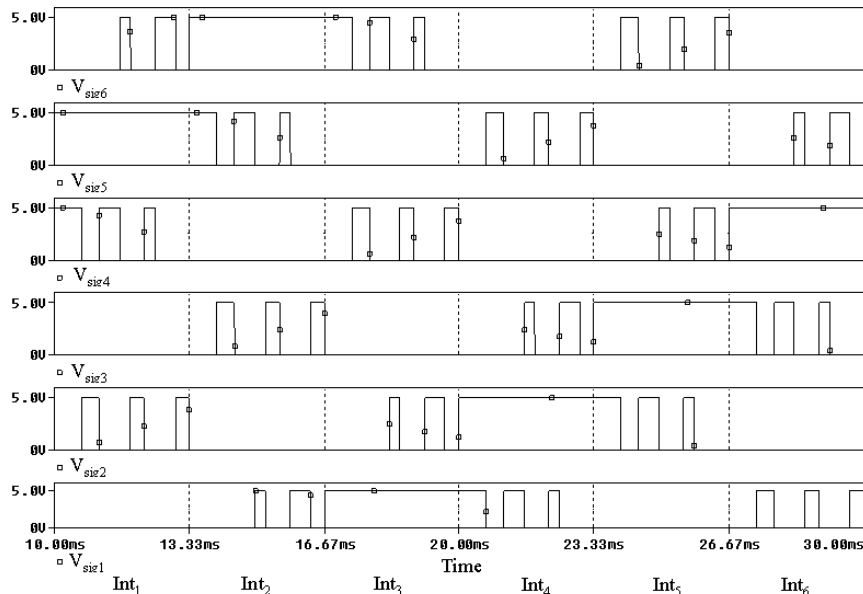

Figure VI.4: The SVM signals in a CSI for  $M = 0.7$  and  $f_c = 900\text{Hz}$

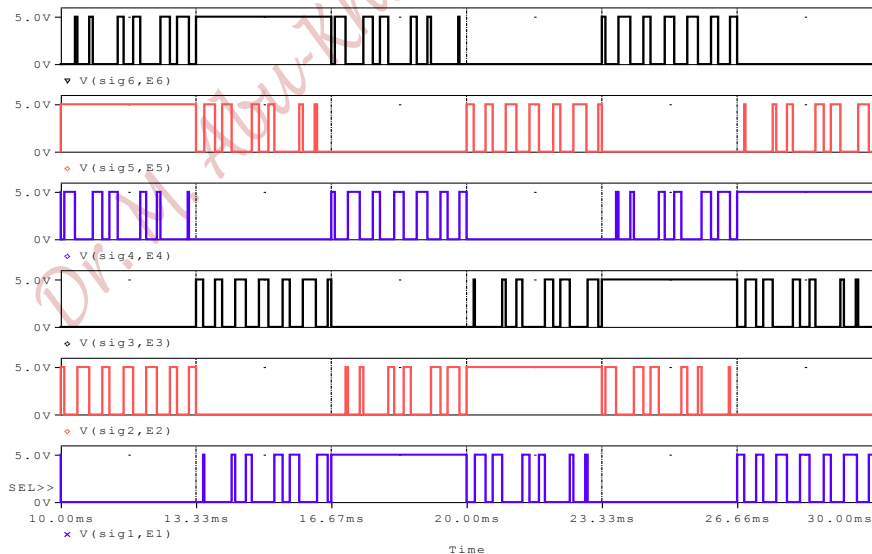
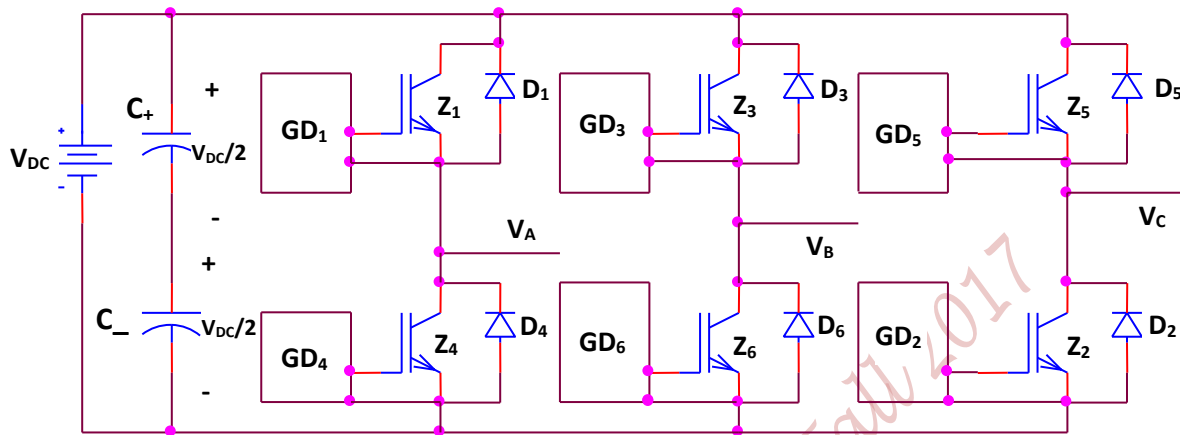

Figure VI.5: The equivalent Sinusoidal PWM signals in a CSI for  $M = 0.7$  and  $f_c = 900\text{Hz}$

Clearly, the switching frequency has been reduced for a similar harmonic content.

## Space Vector Modulation in a Voltage Source Inverter

- ◆ The topology of a three-phase Voltage Source Inverter (VSI) is shown in the Figure below.



- ◆ The Space Vector (SV) is a complex number that can be represented by any three quantities, not necessarily sinusoidal, which add up to zero.
- ◆ The Space Vector Voltage ( $V_n$ ) associated with the AC phase voltages of a three-phase VSI can be generated by a proper selection of the SVs that represent the states.  $V_n$  is given by:

$$V_n = \frac{2}{3} (v_a + v_b * e^{j\frac{2\pi}{3}} + v_c * e^{-j\frac{2\pi}{3}}) = R + jI_m \quad (VI.1')$$

where  $v_a$ ,  $v_b$ , and  $v_c$  are the instantaneous magnitudes of the three-phase line voltages, refer to Figure VI.6,  $R$  and  $I_m$  are the real and the imaginary components of  $V_n$ , respectively.

- ◆ There are 8 states in the VSI: 6 non-zero states and 2 zero states. The space vectors are shown in Figure VI.6. Each state produces three phase voltages as seen in Table VI.4.
- ◆ Assuming that the Space Vector Voltage ( $V_n$ ) is lying between the arbitrary space vectors  $V_i$  and  $V_{i+1}$ , the following expressions can be derived:

$$V_n * t_{\text{cycle}} = V_i * t_i + V_{i+1} * t_{i+1} + V_z * t_z \quad (VI.2')$$

where  $t_{\text{cycle}}$  is the period of one carrier cycle ( $t_{\text{cycle}} = 1/f_c$ ), whilst  $t_i$ ,  $t_{i+1}$ , and  $t_z$  are the times of state  $i$ ,  $i+1$  and zero-state (for  $M \leq 1$ ), respectively. Their values can be calculated using the following equations:

$$t_i = t_{\text{cycle}} * M * \sin((\pi/3) - \theta) \quad (VI.3')$$

$$t_{i+1} = t_{\text{cycle}} * M * \sin(\theta) \quad (VI.4')$$

$$t_z = t_{\text{cycle}} - t_i - t_{i+1} \quad (VI.5')$$

$$\theta = \omega_1 * t \quad (VI.6')$$

$$\omega_1 = 2 * \pi * f_1 \quad (VI.7')$$

Such that  $f_1 = 1/T$ , is the fundamental frequency of the output

The Space Vector Voltage ( $V_n$ ) moves in the complex plane by a step of:

$$\Delta\theta = \frac{360f_1}{f_c} \quad (VI.8')$$

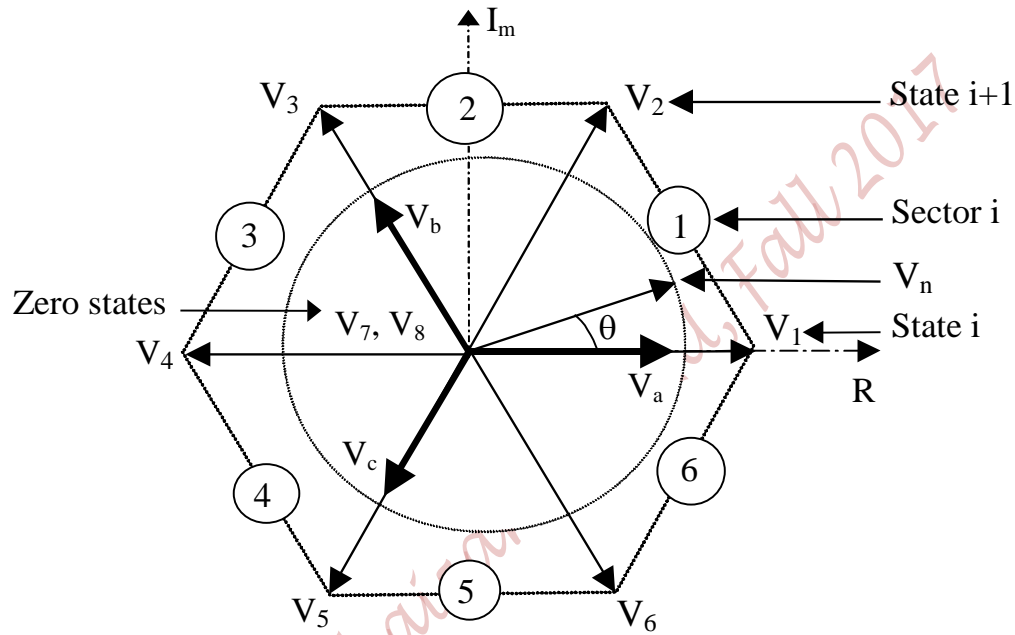

Figure VI.6: Representation of SVs (states) in the complex plane for a VSI

Table VI.4: Possible states and their respective per unit voltages

| State          | 'ON' switches                                    | $v_a / V_{dc}$ | $v_b / V_{dc}$ | $v_c / V_{dc}$ |
|----------------|--|----------------|----------------|----------------|
| V <sub>1</sub> | Z <sub>1</sub> , Z <sub>6</sub> , Z <sub>2</sub> | 1              | 0              | 0              |
| V <sub>2</sub> | Z <sub>1</sub> , Z <sub>3</sub> , Z <sub>2</sub> | 1              | 1              | 0              |
| V <sub>3</sub> | Z <sub>4</sub> , Z <sub>3</sub> , Z <sub>2</sub> | 0              | 1              | 0              |
| V <sub>4</sub> | Z <sub>4</sub> , Z <sub>3</sub> , Z <sub>5</sub> | 0              | 1              | 1              |
| V <sub>5</sub> | Z <sub>4</sub> , Z <sub>6</sub> , Z <sub>5</sub> | 0              | 0              | 1              |
| V <sub>6</sub> | Z <sub>1</sub> , Z <sub>6</sub> , Z <sub>5</sub> | 1              | 0              | 1              |
| V <sub>7</sub> | Z <sub>1</sub> , Z <sub>3</sub> , Z <sub>5</sub> | 1              | 1              | 1              |
| V <sub>8</sub> | Z <sub>4</sub> , Z <sub>6</sub> , Z <sub>2</sub> | 0              | 0              | 0              |

## Switching Sequences in a VSI

There are two **main switching sequences in a VSI**: Direct-Direct sequence and Direct-Inverse sequence.

### 1. Direct-Direct Sequence

It uses  $V_7$ , state 7 (111), as the zero state in sectors 1, 3 and 5, and  $V_8$ , state 8 (000), as the zero state in sectors 2, 4 and 6. The switching sequence remains the same during the same sector; for example in the first sector, the switching sequence  $V_1, V_2, V_7, V_1, V_2, V_7$ , and so on... The switching frequency for this strategy is  $(2/3)*f_c$ .

### 2. Direct-Inverse Sequence

It uses redundancy of the two zero states in the same sector to reduce the number of commutations per cycle. The switching sequence is reversed after passing through each zero state; for example in the first sector, the sequence is  $V_1, V_2, V_7, V_2, V_1, V_8$ , and so on... The advantage of this strategy is that it gives three commutations per cycle and gives symmetrical pulses. The switching frequency for this strategy is  $(1/2)*f_c$ .

Each switching sequence has its own advantages and disadvantages in terms of switching losses and current ripple at the output. The selection of the switching sequence should be made according to the type of load, and the range of Modulation Index, etc.

## SVM and Sinusoidal PWM in a VSI

For  $M = 0.7$  and  $f_c = 900\text{Hz}$ , the sinusoidal PWM gate signals for a VSI are shown in Figure VI.7. On the other hand, Figure VI.8 shows the comparative gate signals obtained by SVM. It is clear that the number of switching transitions is minimized.

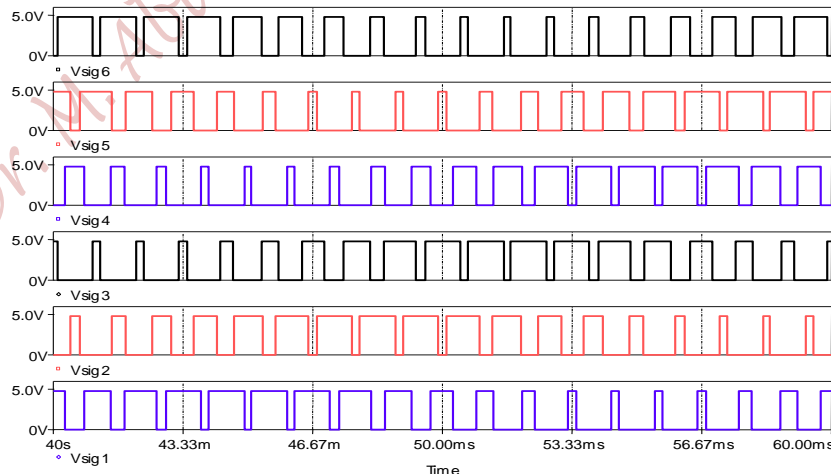

Figure VI.7: The sinusoidal PWM gate signals for a VSI

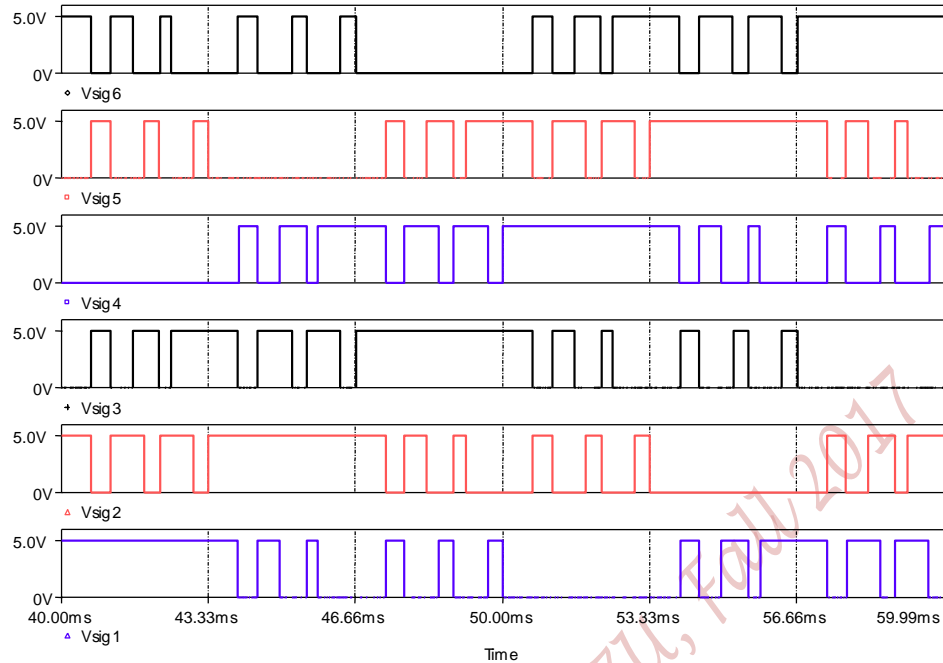

Figure VI.8: The SVM gate signals for a VSI, Direct-Direct sequence

The voltage at the mid-point of the inverter is Pulse Width Modulated and has a fundamental component of 50Hz. Figure VI.9 shows the output voltages of a three phase VSI employing SVM with  $f_c = 900\text{Hz}$  and  $M = 0.7$ . Clearly there are some pulses, which are dropped from the line-to-line voltage ( $V_{AB}$ ).

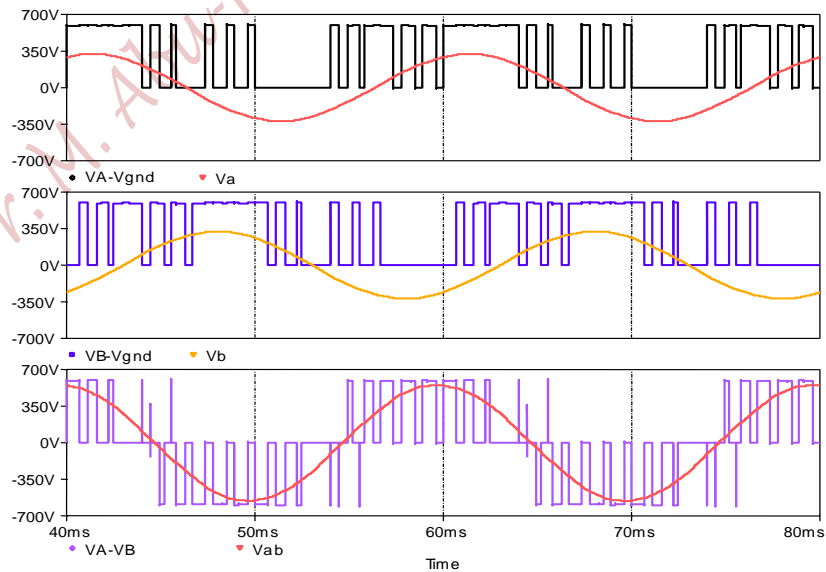

Figure VI.9: The voltage waveforms in a VSI employing SVM



**Example:**

Show that the Square Wave Mode (six-step) is a special case of SVM, whose  $t_{\text{cycle}} = T/6$  (such that  $f_1 = 1/T$ ) and  $M = 1.1547$ .

**Solution:**

The time for state 'i' in sector 'i' is  $t_i = t_{\text{cycle}} * M * \sin((\pi/3)-\theta)$

For  $\theta = 0$  and under the above condition:

$$t_i = T/6$$

$$t_{i+1} = t_{\text{cycle}} * M * \sin(\theta)$$

and

$$t_z = t_{\text{cycle}} - t_i - t_{i+1}$$

Therefore,  $t_{i+1} = 0$ , and  $t_z = 0$ .

Thus, during one sixth of the period, only the switches which correspond to state vector 'i' are 'On'. Similarly, in the sector 'i+1', only the switches which correspond to the state vector 'i+1' are 'On'. Consequently, during one period (20ms), each non-zero state will be used for 3.333ms.

Dr. M. Abu-Khaizaran, BZU, Fall 2017

---

# References

---

- [1] Ned Mohan, Tore M. Undeland, and William P. Robbins, "Power Electronics: Converters, Application, and Design", 3<sup>rd</sup> edition, Wiley, 2002.
- [2] Muhammad Rashid, "Power Electronics: Circuits, Devices and Applications", 4<sup>th</sup> ed. Prentice Hall, 2013.

Dr. M. Abu-Khaizaram, BZU, Fall 2017