

Calculating power losses in an IGBT Module

2014

Application Note



Authors

Noman Rao & Dinesh Chamund

AN6156-1 September 2014 LN31943



Contents

| | |
|--------------------------------------|----|
| Abstract:..... | 3 |
| Introduction:..... | 3 |
| Types of Power Loss..... | 3 |
| Losses Hierarchy:..... | 3 |
| IGBT | 4 |
| Conduction Losses | 5 |
| IGBT output characteristics | 6 |
| Calculating IGBT Losses..... | 7 |
| Switching Losses | 8 |
| Total Losses | 8 |
| Freewheeling diode | 8 |
| Reverse Recovery Time..... | 8 |
| Diode forward characteristics: | 9 |
| Thermal Model..... | 11 |
| Application Example | 12 |
| Two Level Converter | 12 |
| Boost Converter | 13 |



Power Losses in an IGBT Module

Abstract:

The Insulated Gate Bipolar Transistor (IGBT) is an active power semiconductor switch which is well suited for high power applications such as controlling a motor, traction drives, converters, wind turbine etc. This application note will show you how to calculate the losses in the converter/inverter by using Dynex datasheets. If we know the working condition and with the help of some parameters in the datasheet, we can easily calculate the total power loss of the module and hence calculate the junction temperatures.

Introduction:

Power loss in an IGBT mainly consists of steady – state conduction loss and switching loss. The switching loss in the IGBT is given by $E_{sw} = E_{on} + E_{off}$. whereas, in the Diode it is given by the reverse recovery loss. All these switching energies can be added together multiplied by the switching frequency to give the total module switching losses. This note describes the theory behind the calculation and show how to calculate the power losses for the IGBT and Diode and the junction temperatures respectively.

Types of Power Loss

In an IGBT module there are many IGBT die and diode die depending on the module and requirements of the application. All chips dissipate power when they are conducting or switching from one state to another.

Losses Hierarchy:

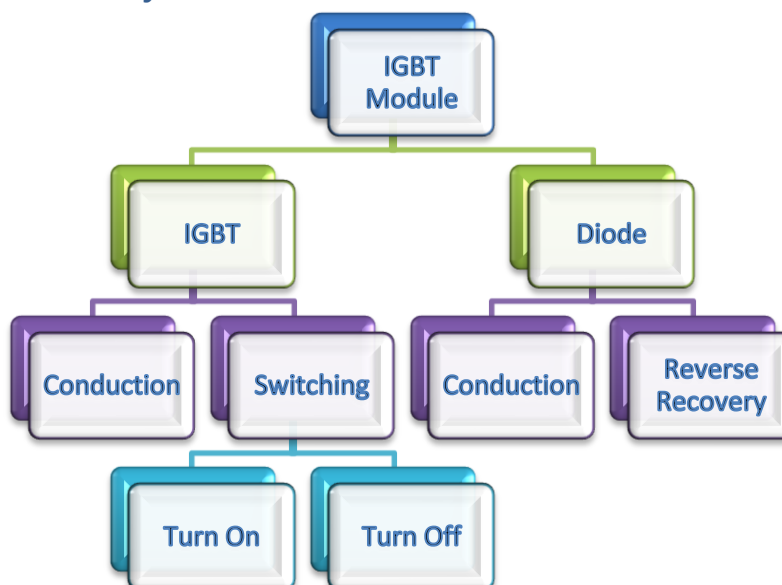

Figure 1: Module Losses Hierarchy



The conduction losses for the IGBT and freewheeling diode are the product of the current flowing through the collector or anode and saturation voltage (on state voltage) over the conducting period. In contrast, the switching losses happen as a result of energy loss during the transition and switching frequency.

IGBT

An IGBT is a voltage-controlled device which combines the advantages of a MOSFET and a BJT. It is a three terminal device; collector, emitter and gate terminal. It is a four layer semiconductor that uses the drive characteristics of a MOSFET and voltage characteristics of BJT. For high power IGBT modules it is necessary to provide a suitable heatsink, otherwise, it may go into the thermal runaway. IGBTs works in two states and produce losses in those states; conduction losses and switching losses.

Conduction losses mainly depend on the duty cycle, load current and junction temperature, whereas, switching losses depends on the load current, dc link voltage, junction temperature and switching frequency. If the switching frequency is higher, then the losses will be higher.

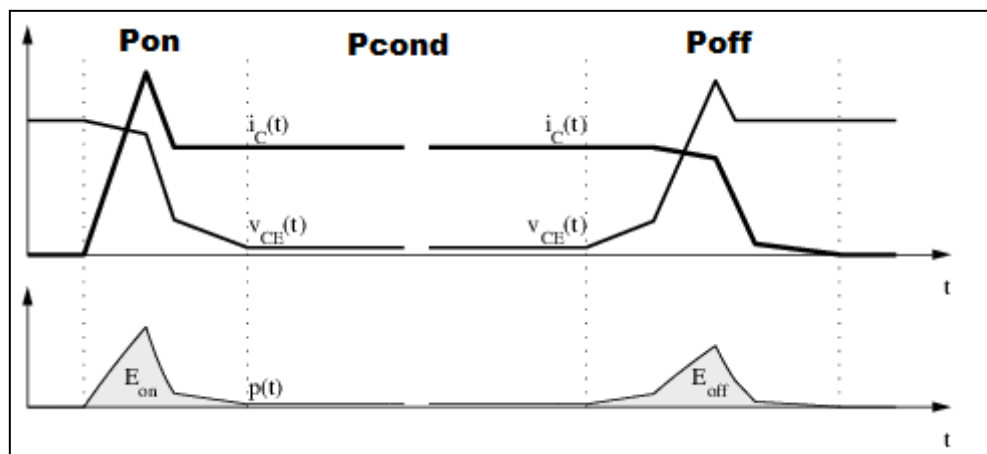

Figure 2: Switching Waveform

Power losses for different stages give significant amount of power loss in an IGBT module if driven carefully.

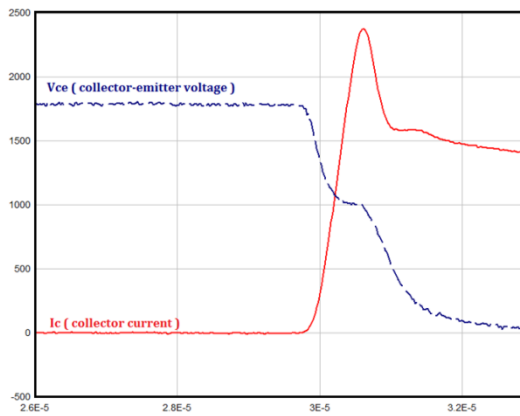

Figure 3: Turn on losses

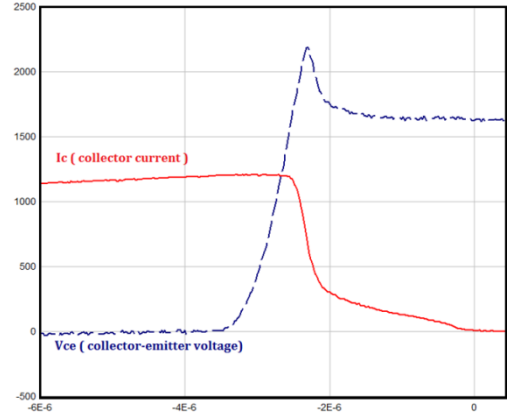

Figure 4: Turn off losses

$$P_{avg.IGBT} = P_{cond} + P_{on} + P_{off} \tag{1}$$

The total average power of the IGBT is the sum of the conduction loss, turn on and turn off losses as shown in Eqn.1.

When the IGBT turns on, collector current increases rapidly and the voltage across the collector to emitter decreases. During this switching it takes time for the current to go from zero to its rated level, also current overshoot can be seen. This overshoot is the mirror image of diode added current and the voltage drops to the saturation level. This transition of voltage and current produce losses called "Pon" turn on power loss. For turn off condition the device behaves in vice versa.

Conduction Losses:

Conduction losses are the losses that occur while the IGBT or freewheeling diode is on and conducting current, the total power dissipation during conduction is computed by multiplying the on-state voltage (Vcesat) and the on-state current (Ic). In PWM applications the conduction loss must be multiplied by the duty factor to obtain average power dissipation. A first order approximation of conduction losses can be obtained by multiplying the IGBT's rated Vce. sat by the expected average device current.

Conduction loss is the on-state loss or steady state loss. The average power dissipated by the IGBT is given by Eqn.2.

$$P_{avg.cond} = \frac{1}{T} \int_0^T [Vce(t) \times Ice(t)] dt \tag{2}$$



IGBT output characteristics:

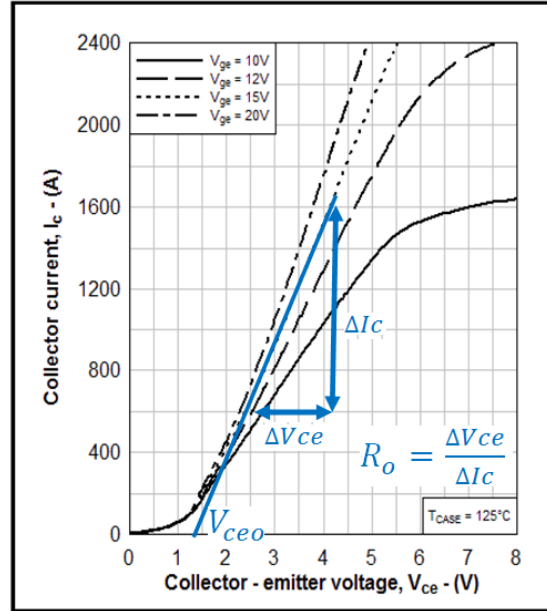

Figure 5: IGBT output characteristic

$$R_o = \frac{V_{ce2} - V_{ce1}}{I_{c2} - I_{c1}} \tag{3}$$

The value for Ro resistance can easily be calculated from the IGBT characteristic curve from the datasheet.

$$V_{ce.sat} = V_{ceo} + R_o \times I_c \tag{4}$$

The Vce. sat value received from the above formula should match with the datasheet value to justify the correct calculation from the graph. The average power losses in PWM sinewave switching in given by Eqn.4.

$$P_{Cond.IGBT} = 0.5 \times \left(V_{ceo} \times \frac{I_{pk}}{\pi} + R_o \times \frac{I_{pk}^2}{4} \right) + m \times \cos \phi \left(V_{ceo} \times \frac{I_{pk}}{8} + R_o \times \frac{I_{pk}^2}{3 \times \pi} \right) \tag{5}$$



Calculating IGBT Losses:

The average power loss in an IGBT is given by the Eqn.2 below

$$P_{avg.cond} = \frac{1}{T} \int_0^T [V_{ce}(t) \times I_{ce}(t)] dt$$

Time period 'T' is inversely proportional to frequency 'f'

$$T = \frac{1}{f}$$

$$P_{avg} = f \int_0^T [P(t)] dt$$

The total average power loss incurred in the IGBT can be obtained by integrating all the values of power losses over a period of time.

The total average power loss for the IGBT can be split into three phases; 1) turning on the device, 2) conducting period and 3) turning off the device.

$$P_{avg.IGBT} = P_{cond} + P_{on} + P_{off}$$

$$P_{avg.IGBT} = \frac{1}{T} \int_{t_{cond}} P(t) dt + f \int_{t_{on}} P(t) dt + f \int_{t_{off}} P(t) dt \quad (6)$$

The conduction losses are independent of the switching frequency but dependant on the duty cycle, whereas the switching losses are dependant of the switching frequency and therefore they are directly proportional to each other.

The values for the energy loss E_{on} and E_{off} are given in the Dynex datasheet, therefore there is no need to calculate these values. The switching energies are then simply multiplied by the switching frequency to give the power loss for on and off time as shown in Eqn.7.

The total average conduction loss can also be calculated by another method if we can calculate the values from I_{rms} and I_{avg} for the system.

V_o and R_o values can be measured from the datasheet by just drawing a tangent line passing through the rated value as shown in Fig 5. These values vary with the temperature therefore at 125°C it is higher than 25°C.



Switching Losses:

In power electronics switching losses typically contribute a significant amount to the total system losses. Therefore, omitting switching losses in the calculation or weighting the conduction losses with an estimated factor to take into account switching losses, might result in large errors concerning the total losses switching losses occurred because the transitions from on-state to off-state and vice versa do not occur instantaneously. During the transition interval both the current through and the voltage across the device are substantially larger than zero which leads to large instantaneous power loss. The curves show the simplified current and voltage waveforms and the dissipated power during one switching cycle of an IGBT in an inverter leg. If one plans to calculate the junction temperature time behaviour to improve reliability of the design, it is necessary to calculate accurately the switching losses.

$$P_{sw.IGBT} = (E_{on} + E_{off}) \times f_{sw} \quad (7)$$

The switching power loss needs to be normalized with the conditions provided for any application with the nominal values of datasheet.

$$P_{sw.IGBT} = \frac{(E_{on} + E_{off}) \times I_{pk} \times f_{sw} \times V_{dc}}{\pi \times I_{nom} \times V_{nom}} \quad (8)$$

Total Losses:

$$P_{avg.IGBT} = P_{Cond.IGBT} + P_{sw.IGBT} \quad (9)$$

The more points we add in the calculations, the more accurate will be the losses.

Freewheeling Diode

A diode is a two-terminal pn-junction device; anode and cathode. It allows current to pass in one direction (conduction state), while blocking current in the opposite direction (the reverse direction). The average total power losses in diode is given by Eqn.10.

$$P_{avg.Diode} = P_{cond.Diode} + P_{rec.Diode} \quad (10)$$

Reverse Recovery Time:

When switching from the conduction to the blocking state, a diode or rectifier has stored charge that must be discharged first before the diode blocks reverse voltage. This discharge takes a finite amount of time known as the Reverse Recovery Time, or t_{rr} . During this time, diode current may flow in the reverse direction.

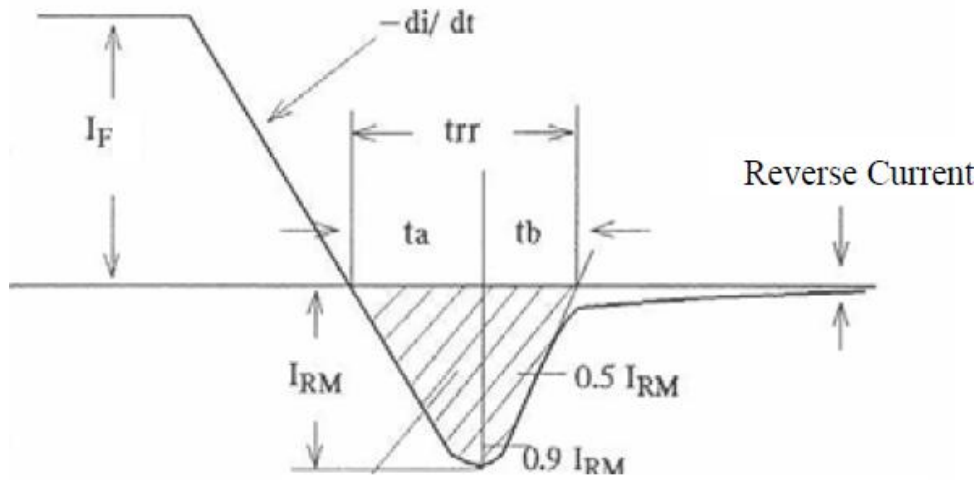

Figure 6: Reverse recovery time

When the device turns off it generates losses called recovery loss and the time required to recover is called the reverse recovery time.

Diode forward characteristics:

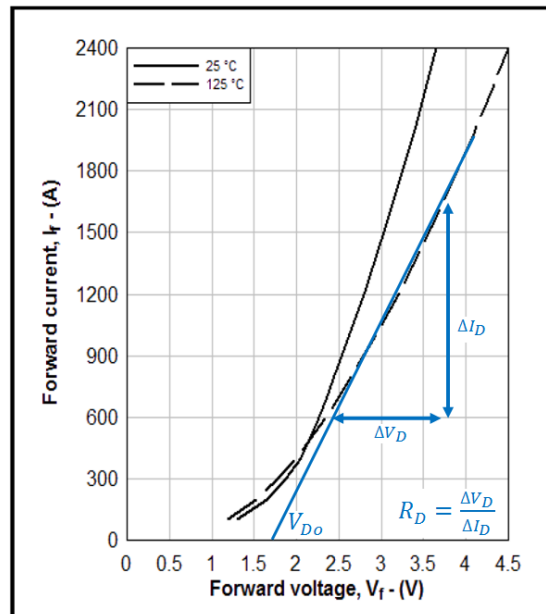

Figure 7: Forward characteristic of diode datasheet

$$R_D = \frac{V_{f2} - V_{f1}}{I_{f2} - I_{f1}} \tag{11}$$

Change of forward voltage and forward current can give the R_D resistance value.

$$V_f = V_{D0} + R_D \times I_c \tag{12}$$



Diode threshold voltage can be calculated from the above graph see Fig. 7 which is used for calculating the forward voltage see Eqn.12. This forward voltage can be checked against the datasheet value to give the confirmation of calculation. The average power losses in diode are when operated under PWM sinewave switching is given by Eqn.13.

$$P_{Cond.Diode} = 0.5 \times \left(V_{Do} \times \frac{I_{pk}}{\pi} + R_D \times \frac{I_{pk}^2}{4} \right) - m \times \cos \phi \left(V_{Do} \times \frac{I_{pk}}{8} + R_D \times \frac{I_{pk}^2}{3 \times \pi} \right) \quad (13)$$

$$P_{rec.Diode} = E_{rec} \times f_{sw}$$

The switching power loss needs to be normalized with the conditions provided for any application with the nominal values of datasheet.

$$P_{rec.Diode} = \frac{E_{rec} \times I_{pk} \times f_{sw} \times V_{dc}}{\pi \times I_{nom} \times V_{nom}} \quad (14)$$

$$P_{avg.Diode} = P_{Cond.Diode} + P_{rec.Diode}$$

The total average power loss for the diode is the sum of conduction loss in diode and reverse recovery.



Thermal Model:

The junction temperature T_j is given by the Eqn.15 and is illustrated in Fig.8.

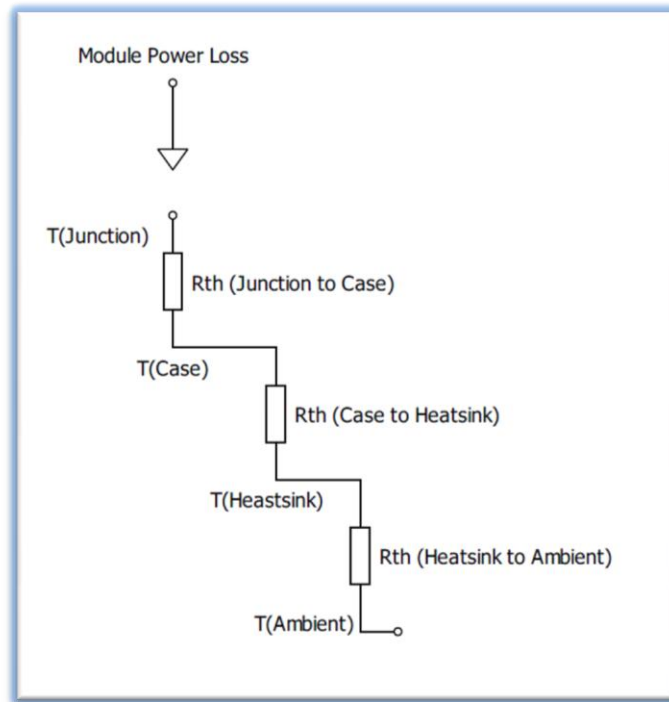

Figure 8: Transient thermal model

$$T_j = P \times \{ Rth_{j-c} + Rth_{c-hs} + Rth_{hs-a} \} + T_a \quad (15)$$

Where;

T_j = Junction temperature

P = Module power loss

Rth_{j-c} = Thermal Resistance junction to case

Rth_{c-hs} = Thermal Resistance case to heatsink

Rth_{hs-a} = Thermal Resistance heatsink to ambient

T_a = Ambient temperature



Application Example

Two Level Converter:

Here are some graphs and results for the Dynex IGBT module DIM1200ASM45-TS000 using the 2-level converter topology and PWM sinewave switching.

| Input | | Results | | IGBT | Diode |
|--------------------------|------------|----------------------------------|------|------|-------|
| Vdc (V) | 2800 | Pconduction losses (W) | 894 | 159 | |
| Iorms (A) | 800 | Pswitching losses (W) | 1332 | 450 | |
| Ipk (A) | 1131.37085 | Ptotal losses per device (W) | 2227 | 609 | |
| Ipk2 (A) | 1280000 | $\Delta T(j-hs)$ ($^{\circ}C$) | 31 | 13 | |
| Freq.sw (Hz) | 400 | Total losses per module (W) | 2836 | | |
| PF (Cos ϕ) | 0.85 | $\Delta T(hs-a)$ ($^{\circ}C$) | 20 | | |
| Modulation Index m | 1 | Tj ($^{\circ}C$) | 111 | 93 | |
| Ambient Temp $^{\circ}C$ | 60 | | | | |

| Datasheet | | | |
|-----------------------------|----------|-----------------------------|----------|
| DIM1200ASM45-TS000 | | | |
| Temp=125 $^{\circ}C$ | | | |
| IGBT | | DIODE | |
| Eon (J) | 6.45 | Erec (J) | 3.75 |
| Eoff (J) | 4.65 | | |
| Inom (A) | 1200 | Inom (A) | 1200 |
| Vnom (V) | 2800 | Vnom (V) | 2800 |
| Vceo (V) | 1.44 | Vdo (V) | 1.79 |
| Ro (Ω) | 0.001677 | Rd (Ω) | 0.001167 |
| Rth(j-c) ($^{\circ}C/W$) | 0.008 | Rth(j-c) ($^{\circ}C/W$) | 0.016 |
| Rth(c-h) ($^{\circ}C/W$) | 0.006 | Rth(c-h) ($^{\circ}C/W$) | 0.006 |
| Rth(j-h) ($^{\circ}C/W$) | 0.014 | Rth(j-h) ($^{\circ}C/W$) | 0.022 |
| Rth(hs-a) ($^{\circ}C/W$) | 0.007 | Rth(hs-a) ($^{\circ}C/W$) | 0.007 |

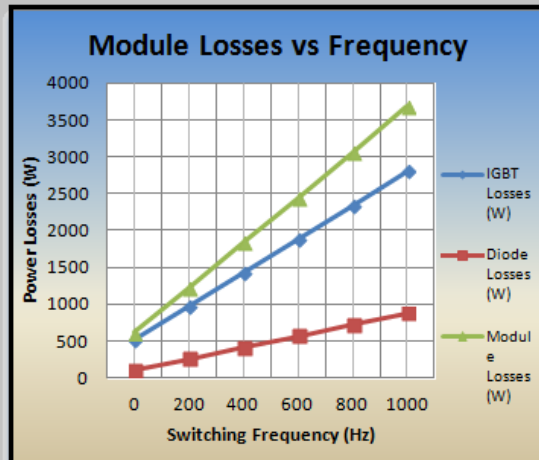
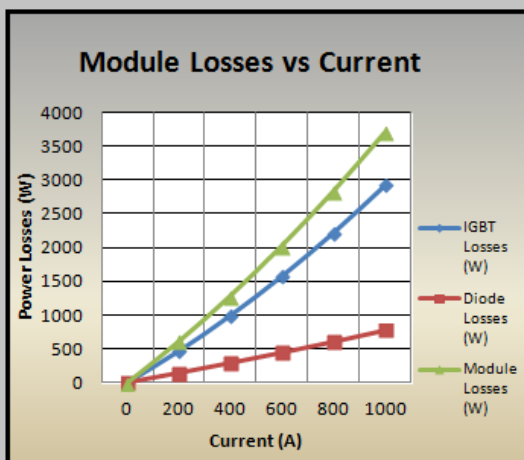

The software is calculating the power losses for IGBT and Diode and the junction temperatures. The key parameters from the datasheet are also displayed in the datasheet table.



Boost Converter:

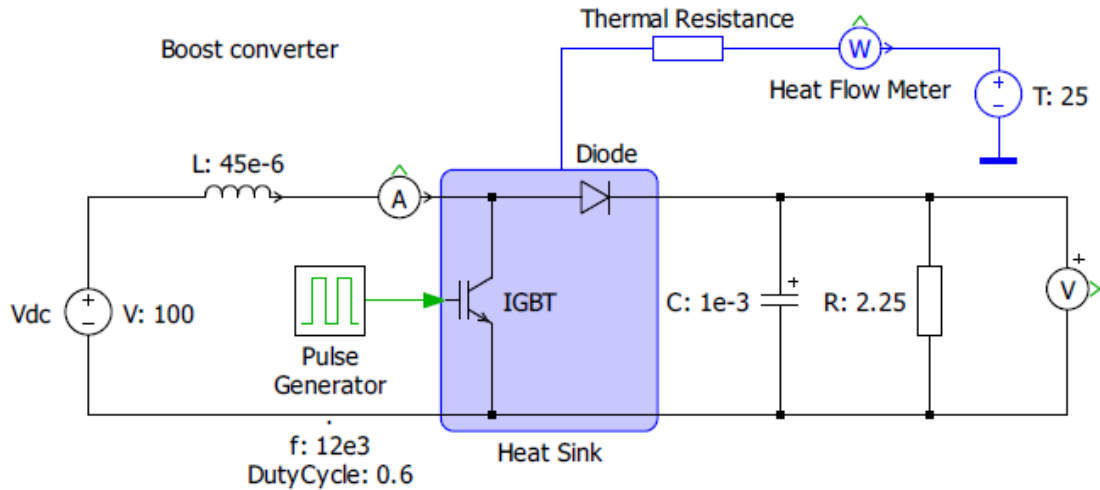

This is an example using PLECS software showing how the Dynex devices can be used for a boost converter. The electrical and thermal circuit are shown above. This will show you how to calculate the power losses for IGBT and Diode.

The switching time for an IGBT can be control by the duty cycle;

The duty cycle is $D = T_{on}/T$

Where,

T_{on} = IGBT turn on time

T = Time period for one cycle

$$\frac{di_L}{dt} = \frac{V_{in}}{L}$$

Therefore $V_L = V_{in}$

With the diode continuously conducting and the IGBT behaving as an open switch

Then duty cycle will be $(1 - D)T$

$$\frac{di_L}{dt} = \frac{V_{in} - V_{out}}{L}$$

Therefore $V_L = V_{in} - V_{out}$



Since the average voltage across the inductor is zero

$$V_{Lavg} = D \times V_{in} + (1 - D) \times (V_{in} - V_{out}) = 0$$

$$D \times V_{in} + (V_{in} - D \times V_{in} - V_{out} + D \times V_{out}) = 0$$

$$V_{in} - V_{out} + D \times V_{out} = 0$$

$$V_{out} = \frac{V_{in}}{1 - D}$$

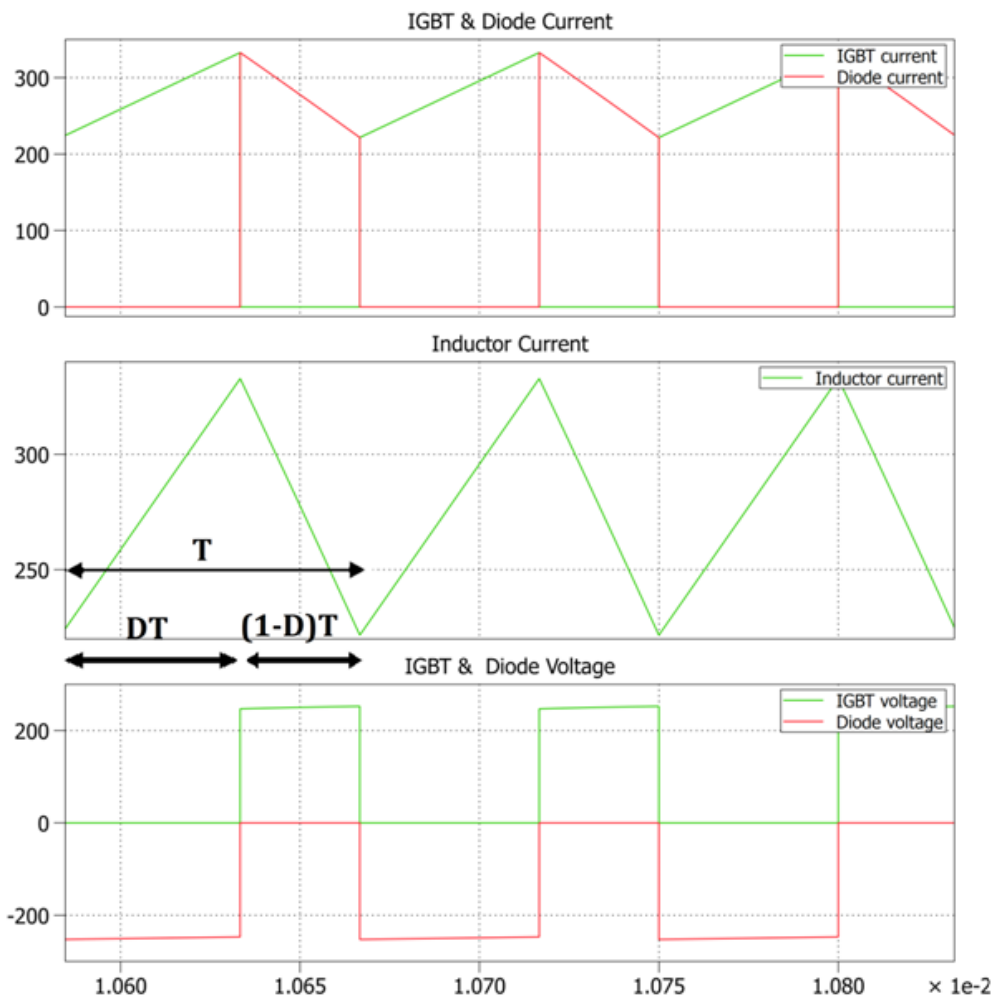

Figure 9: Simulation waveform



The conduction losses for the Boost converter can be calculated by,

$$P_{avg.cond} = \frac{1}{T} \int_{t_{cond}} V_{ce}(t) \times I_c(t) dt = \frac{1}{T} \int_{t_{cond}} (V_o + R_o I_c(t)) I_c(t) dt$$

$$P_{avg.cond} = \frac{1}{T} \int_{t_{cond}} (V_o \times I_c(t) + R_o I_c^2(t)) dt$$

$$P_{avg.cond} = V_o \frac{1}{T} \int_{t_{cond}} I_c(t) dt + R_o \frac{1}{T} \int_{t_{cond}} I_c^2(t) dt$$

$$P_{avg.cond} = V_o \times I_{avg} + R_o \times I_{rms}^2$$

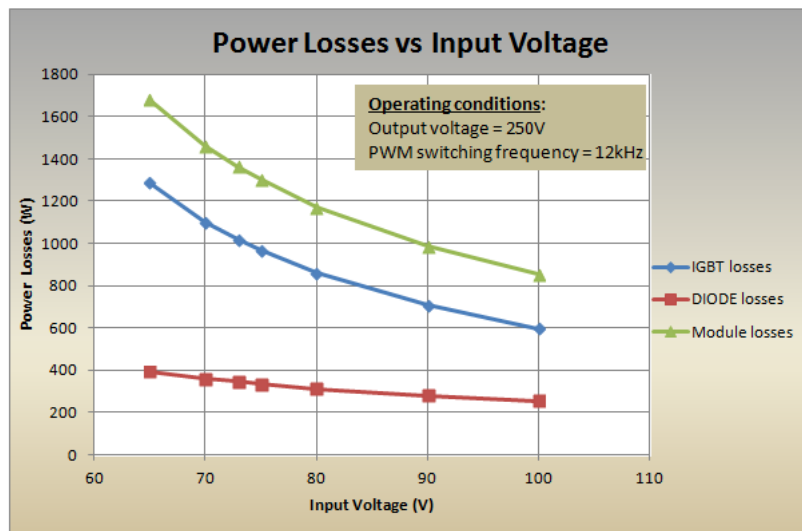

Figure 10: Boost converter IGBT module power losses



IMPORTANT INFORMATION:

This publication is provided for information only and not for resale.

The products and information in this publication are intended for use by appropriately trained technical personnel.

Due to the diversity of product applications, the information contained herein is provided as a general guide only and does not constitute any guarantee of suitability for use in a specific application. The user must evaluate the suitability of the product and the completeness of the product data for the application. The user is responsible for product selection and ensuring all safety and any warning requirements are met. Should additional product information be needed please contact Customer Service.

Although we have endeavoured to carefully compile the information in this publication it may contain inaccuracies or typographical errors. The information is provided without any warranty or guarantee of any kind.

This publication is an uncontrolled document and is subject to change without notice. When referring to it please ensure that it is the most up to date version and has not been superseded.

The products are not intended for use in applications where a failure or malfunction may cause loss of life, injury or damage to property. The user must ensure that appropriate safety precautions are taken to prevent or mitigate the consequences of a product failure or malfunction.

The products must not be touched when operating because there is a danger of electrocution or severe burning. Always use protective safety equipment such as appropriate shields for the product and wear safety glasses. Even when disconnected any electric charge remaining in the product must be discharged and allowed to cool before safe handling using protective gloves.

Extended exposure to conditions outside the product ratings may affect reliability leading to premature product failure. Use outside the product ratings is likely to cause permanent damage to the product. In extreme conditions, as with all semiconductors, this may include potentially hazardous rupture, a large current to flow or high voltage arcing, resulting in fire or explosion. Appropriate application design and safety precautions should always be followed to protect persons and property.

Product Status & Product Ordering:

We annotate datasheets in the top right hand corner of the front page, to indicate product status if it is not yet fully approved for production. The annotations are as follows:-

Target Information: This is the most tentative form of information and represents a very preliminary specification.
No actual design work on the product has been started.

Preliminary Information: The product design is complete and final characterisation for volume production is in progress. The datasheet represents the product as it is now understood but details may change.

No Annotation: The product has been approved for production and unless otherwise notified by Dynex any product ordered will be supplied to the **current version of the data sheet prevailing at the time of our order acknowledgement.**

All products and materials are sold and services provided subject to Dynex's conditions of sale, which are available on request.

Any brand names and product names used in this publication are trademarks, registered trademarks or trade names of their respective owners.

HEADQUARTERS OPERATIONS

DYNEX SEMICONDUCTOR LTD

Doddington Road, Lincoln, Lincolnshire, LN6 3LF,
United Kingdom

Fax: +44(0)1522 500550
Tel: +44(0)1522 500500
Web: <http://www.dynexsemi.com>

CUSTOMER SERVICE

DYNEX SEMICONDUCTOR LTD

Doddington Road, Lincoln, Lincolnshire, LN6 3LF, United
Kingdom

Fax: +44(0)1522 500020
Tel: +44(0)1522 502753 / 502901
Email: Power_solutions@dynexsemi.com