

Chapter 3

Amplitude Modulation



Wireless Information Transmission System Lab.
Institute of Communications Engineering
National Sun Yat-sen University

Outline



- ◇ 3.1 Introduction
- ◇ 3.2 Amplitude Modulation
- ◇ 3.3 Double Sideband-Suppressed Carrier Modulation
- ◇ 3.4 Quadrature-Carrier Multiplexing
- ◇ 3.5 Single-Sideband and Vestigial-Sideband Methods of Modulation
- ◇ 3.7 Frequency Translation

Chapter 3.1

Introduction



Wireless Information Transmission System Lab.
Institute of Communications Engineering
National Sun Yat-sen University

3.1 Introduction



- ◇ Purpose of a communication system: convey information through a medium or communication channel.
- ◇ The information is often represented as a baseband signal (基頻訊號), i.e. a signal whose spectrum extends from 0 to some maximum frequency.
- ◇ Proper utilization of the communication channel often requires a shift of the range of baseband frequencies into other frequency ranges suitable for transmission, and a corresponding shift back to the original frequency range after reception.
- ◇ A shift of the range of frequencies in a signal is accomplished by using modulation, which is defined as the process by which some characteristic of a carrier is varied in accordance with a modulating wave (signal).

3.1 Introduction



- ◇ A common form of the carrier is a *sinusoidal wave*, in which case we speak of *continuous-wave modulation*.
- ◇ The baseband signal is referred to as the *modulating wave*, and the result of the modulation process is referred to as the *modulated wave*.
- ◇ *Modulation* is performed at the transmitting end.
- ◇ At the receiving end, we require the original baseband signal to be restored. This is accomplished by using a process known as *demodulation*, which is the reverse of the modulation process.
- ◇ CW: continuous-wave.

Chapter 3.2

Amplitude Modulation



Wireless Information Transmission System Lab.
Institute of Communications Engineering
National Sun Yat-sen University

3.2 Amplitude Modulation



- ◇ A *sinusoidal carrier wave*:

$$c(t) = A_c \cos(2\pi f_c t) \quad (3.1)$$

A_c is the carrier amplitude
 f_c is the carrier frequency
Phase is assumed to be 0.

- ◇ *AM is defined as a process in which the amplitude of the carrier wave $c(t)$ is varied about a mean value, linearly with baseband signal $m(t)$.*

- ◇ AM wave, in its most general form

$$s(t) = A_c [1 + k_a m(t)] \cos(2\pi f_c t) \quad (3.2)$$

- ◇ Typically, the carrier amplitude A_c and the message signal $m(t)$ are measured in volts, in which case the k_a is measured in volt^{-1} .
- ◇ k_a : amplitude sensitivity. [volt^{-1}]
- ◇ $m(t)$: modulating wave; the baseband signal that carries the message.
- ◇ $s(t)$: modulated wave.
- ◇ $m(t)$ and A_c are measured in volts.

3.2 Amplitude Modulation



- ◇ The envelope of $s(t)$ has essentially the same shape as the baseband signal $m(t)$ provided that two requirements are satisfied:
 - ◇ **1.** The amplitude of $k_a m(t)$ is always less than unity, that is,

$$|k_a m(t)| < 1 \text{ for all } t \quad (3.3)$$

- ◇ It ensures that the function $1 + k_a m(t)$ is always positive, and since an envelope is a positive function, we may express the envelope of the AM wave $s(t)$ of Eq. (3.2) as $A_c[1 + k_a m(t)]$.
- ◇ When $|k_a m(t)| > 1$ for any $t \rightarrow$ the carrier wave becomes overmodulated, resulting in carrier phase reversals whenever the factor $1 + k_a m(t)$ crosses zero. (envelope distortion)
- ◇ The absolute maximum value of $k_a m(t)$ multiplied by 100 is referred to as the percentage modulation.

3.2 Amplitude Modulation

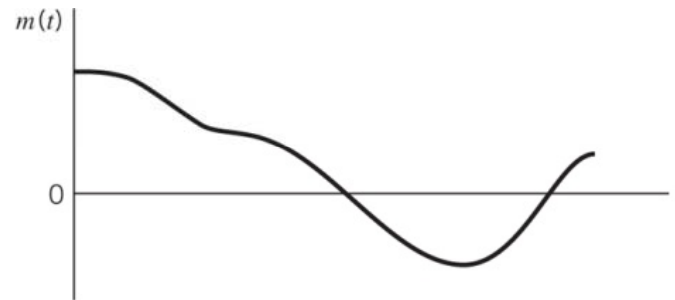

(a) Baseband signal $m(t)$

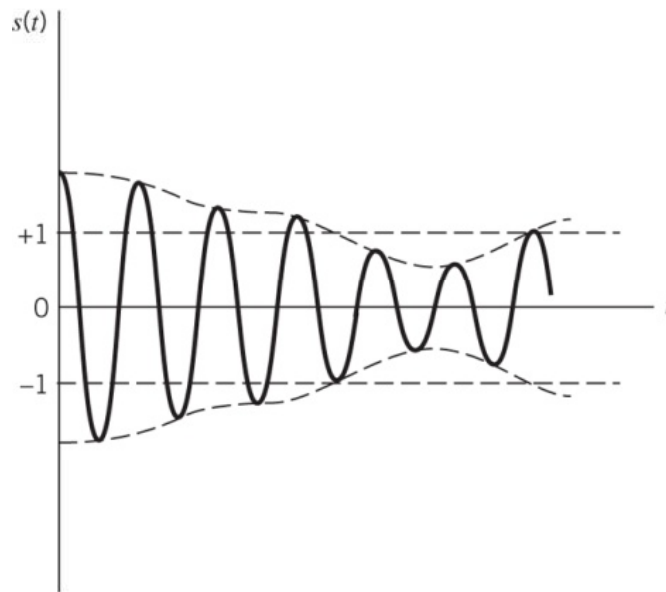

(b)

AM wave for $|k_a m(t)| < 1$ for all t

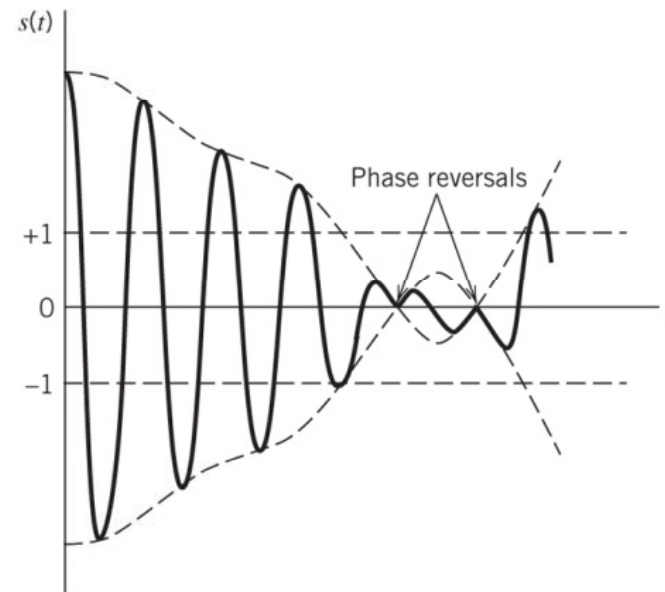

(c)

AM wave for $|k_a m(t)| > 1$ for some t
Envelope distortion

3.2 Amplitude Modulation



- 2. The carrier frequency f_c is much greater than the highest frequency component W of the message signal $m(t)$, that is

$$f_c \gg W \tag{3.4}$$

- We call W the message bandwidth. If the condition of Eq. (3.4) is not satisfied, an envelope can not be visualized satisfactorily.
- From Eq. (3.2), we find that the Fourier transform of the AM wave $s(t)$ is given by $s(t) = A_c [1 + k_a m(t)] \cos(2\pi f_c t)$ (3.2) $\cos(2\pi f_c t) \Leftrightarrow \frac{1}{2} [\delta(f - f_c) + \delta(f + f_c)]$

$$S(f) = \frac{A_c}{2} [\delta(f - f_c) + \delta(f + f_c)] + \frac{k_a A_c}{2} [M(f - f_c) + M(f + f_c)] \tag{3.5}$$

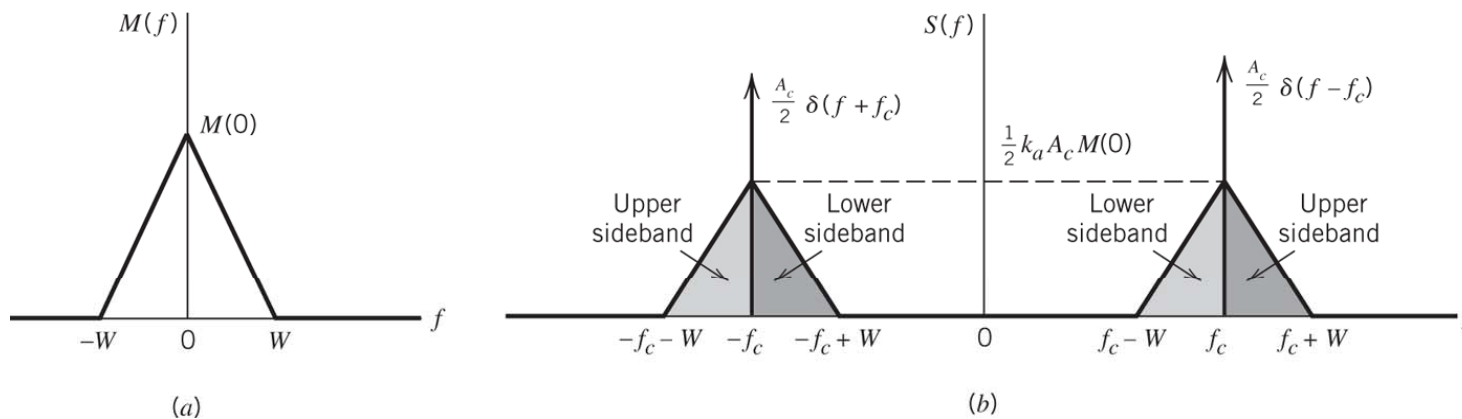

3.2 Amplitude Modulation



- ◇ From the spectrum of $S(f)$, we note the following:
 - ◇ 1. As a result of the modulation process, the spectrum of the message signal $m(t)$ for negative frequencies extending from $-W$ to 0 becomes completely visible for positive frequencies, provided that the carrier frequency satisfies the condition $f_c > W$.
 - ◇ 2. For positive frequencies: The spectrum of an AM wave above f_c is referred to as the upper sideband, below f_c is referred to as the lower sideband. For negative frequencies: The upper sideband is below $-f_c$ and the lower sideband is above $-f_c$. The condition $f_c > W$ ensures that the sidebands do not overlap.
 - ◇ 3. For positive frequencies, the highest frequency component of the AM wave equals $f_c + W$, and the lowest frequency component equals $f_c - W$. The difference between these two frequencies defines the transmission bandwidth B_T for an AM wave.

$$B_T = 2W \quad (3.6)$$

3.2 Amplitude Modulation



◇ Example 3.1 Single-Tone Modulation (1/3)

◇ Consider a modulating wave: $m(t) = A_m \cos(2\pi f_m t)$

◇ carrier wave: $c(t) = A_c \cos(2\pi f_c t)$

$$s(t) = A_c [1 + \mu \cos(2\pi f_m t)] \cos(2\pi f_c t) \quad (3.7)$$

where $\mu = k_a A_m \dots \dots \dots \rightarrow \mu$: modulation factor
(or percentage modulation)

◇ To avoid overmodulation $\rightarrow |\mu| < 1$

◇ Envelope of $s(t)$: $A_c [1 + \mu \cos(2\pi f_m t)]$

$$\frac{A_{\max}}{A_{\min}} = \frac{A_c (1 + \mu)}{A_c (1 - \mu)} \Rightarrow \mu = \frac{A_{\max} - A_{\min}}{A_{\max} + A_{\min}}$$

◇ A_{\max} and A_{\min} denote the maximum and minimum values of the envelope of the modulated wave.

3.2 Amplitude Modulation



◇ Example 3.1 Single-Tone Modulation (2/3)

◇ Eq. (3.7) can be represented in this form: $\cos A \cos B = \frac{1}{2} \{ \cos(A-B) + \cos(A+B) \}$

$$\begin{aligned}
 s(t) &= A_c \cos(2\pi f_c t) + \frac{1}{2} \mu A_c \cos[2\pi(f_c + f_m)t] + \frac{1}{2} \mu A_c \cos[2\pi(f_c - f_m)t] \\
 S(f) &= \frac{1}{2} A_c [\delta(f - f_c) + \delta(f + f_c)] + \frac{1}{4} \mu A_c [\delta(f - f_c - f_m) + \delta(f + f_c + f_m)] \\
 &\quad + \frac{1}{4} \mu A_c [\delta(f - f_c + f_m) + \delta(f + f_c - f_m)]
 \end{aligned}$$

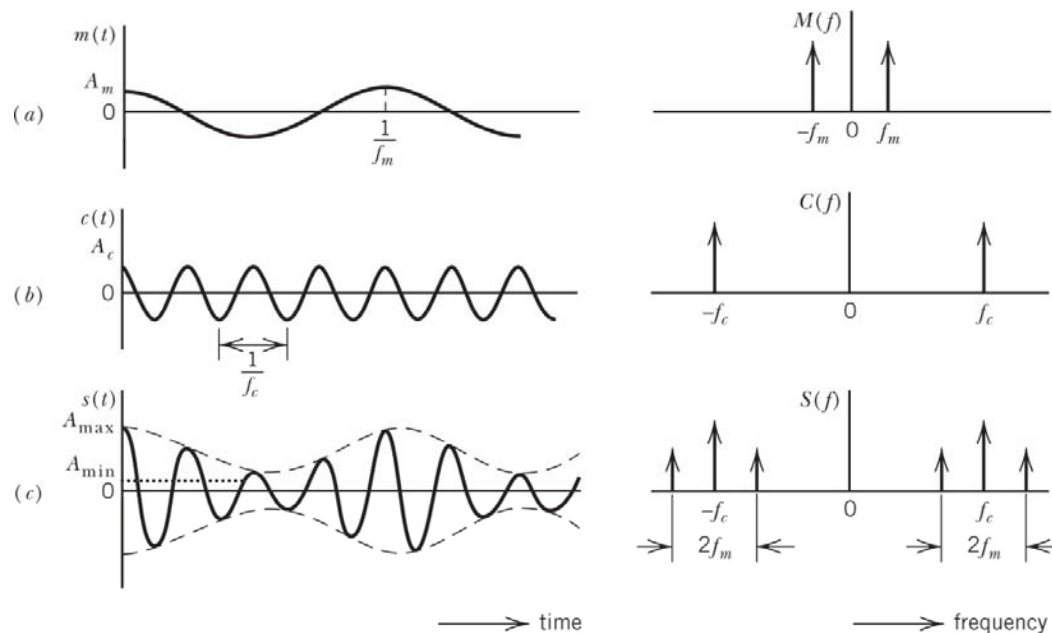

3.2 Amplitude Modulation



◇ Example 3.1 Single-Tone Modulation (3/3)

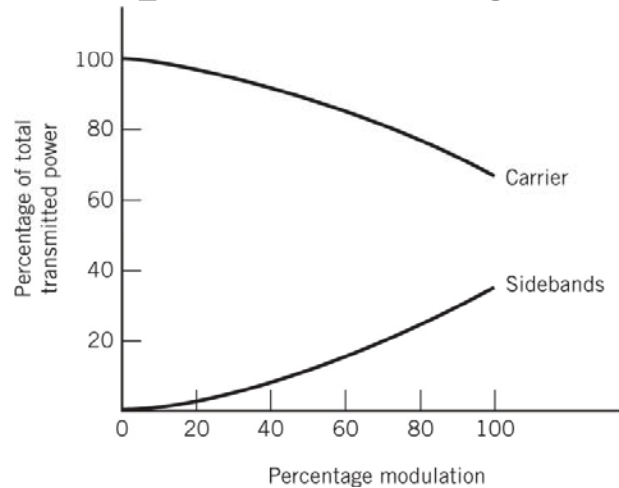

$$\text{Carrier power} = \frac{1}{2} A_c^2$$

$$\text{Upper side-frequency power} = \frac{1}{8} \mu^2 A_c^2$$

$$\text{Lower side-frequency power} = \frac{1}{8} \mu^2 A_c^2$$

- ◇ In any case, the ratio of the total sideband power to the total power in the modulated wave is equal to

$$\mu^2 / (2 + \mu^2)$$

- ◇ Depend only on the modulation factor μ .
- ◇ If $\mu=1$, the total power in the two side frequencies of the resulting AM wave is only one-third of the total power in the modulated wave.
- ◇ When the percentage modulation is less than 20 percent, the power in one side frequency is less than 1 percent of the total power in the AM wave.

3.2 Amplitude Modulation



- ◇ Switching Modulator (1/4)

- ◇ One way to generate an AM wave: Switching Modulator.

- ◇ Assume carrier wave $c(t)$ is large in amplitude and the diode acts as an *ideal switch*.

$$v_1(t) = A_c \cos(2\pi f_c t) + m(t) \quad (3.8)$$

$$v_2(t) \approx \begin{cases} v_1(t), & c(t) > 0 \\ 0, & c(t) < 0 \end{cases} \quad (3.9)$$

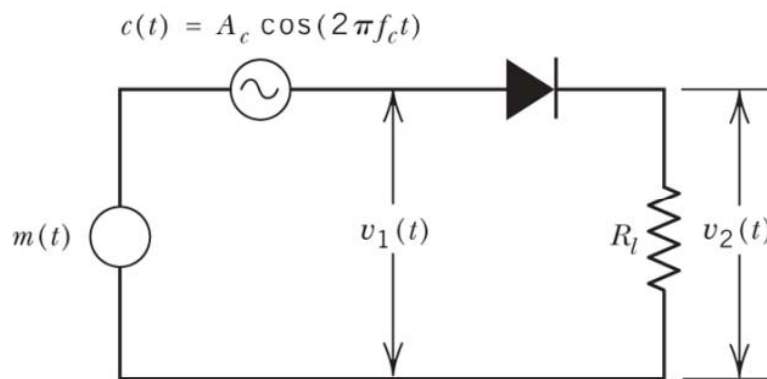

(a)

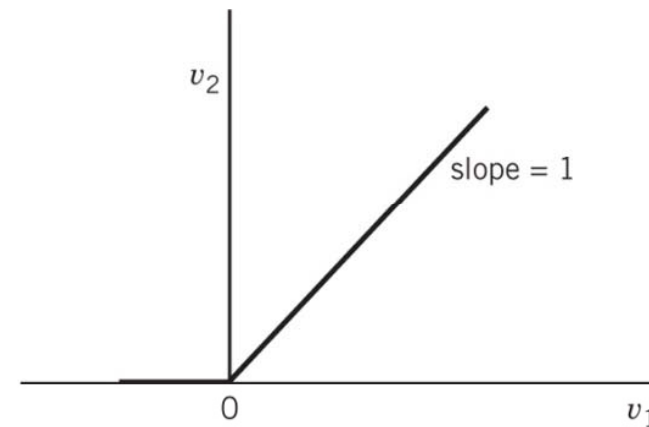

(b)

3.2 Amplitude Modulation



◇ Switching Modulator (2/4)

- ◇ From Eq. (3.9), load voltage $v_2(t)$ varies periodically between the values $v_1(t)$ and zeros at a rate equal to the carrier frequency f_c .
- ◇ By assuming a modulating wave that is weak compared with the carrier wave, we have effectively replace the nonlinear behavior of the diode by an approximately equivalent piecewise-linear time-varying operation.
- ◇ We may express Eq. (3.9) mathematically as

$$v_2(t) \approx [A_c \cos(2\pi f_c t) + m(t)] g_{T_0}(t) \quad (3.10)$$

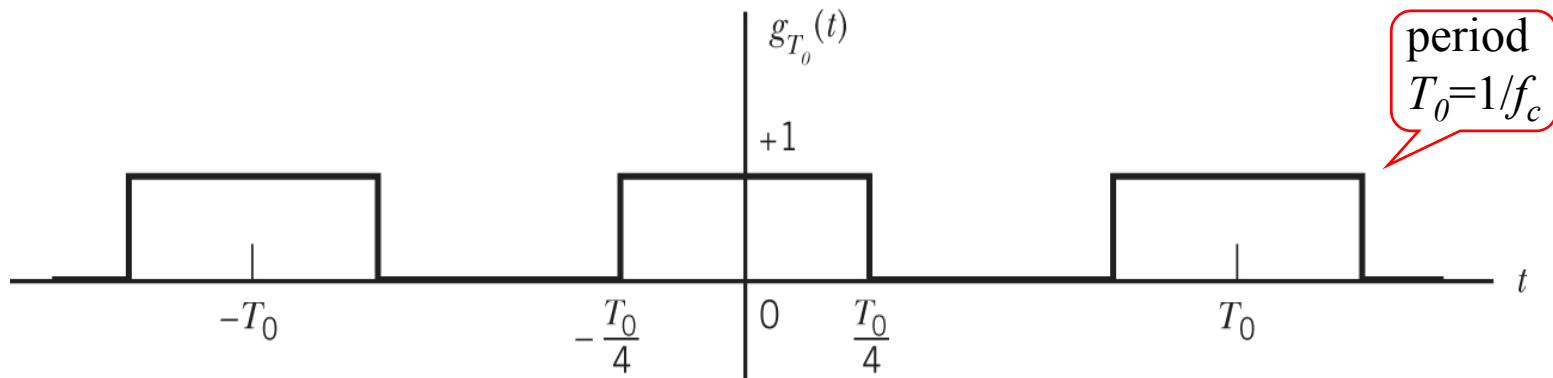

3.2 Amplitude Modulation



◇ Switching Modulator (3/4)

$$g_{T_0}(t) = a_0 + \sum_{n=1}^{\infty} \left(a_n \cos\left(2\pi \frac{n}{T_0} t\right) + b_n \sin\left(2\pi \frac{n}{T_0} t\right) \right)$$

$$a_0 = \frac{1}{T_0} \int_{-T_0/2}^{T_0/2} g_{T_0}(t) dt$$

$$a_n = \frac{2}{T_0} \int_{-T_0/2}^{T_0/2} g_{T_0}(t) \cos\left(2\pi \frac{n}{T_0} t\right) dt$$

$$b_n = \frac{2}{T_0} \int_{-T_0/2}^{T_0/2} g_{T_0}(t) \sin\left(2\pi \frac{n}{T_0} t\right) dt$$

$$b_n = \frac{2}{T_0} \int_{-T_0/4}^{T_0/4} \sin\left(2\pi \frac{n}{T_0} t\right) dt = -\frac{2}{T_0} \frac{\cos\left(2\pi \frac{n}{T_0} t\right)}{2\pi \frac{n}{T_0}} \Bigg|_{-T_0/4}^{T_0/4}$$

$$= -\frac{1}{n\pi} \left[\cos\left(\frac{n\pi}{2}\right) - \cos\left(-\frac{n\pi}{2}\right) \right] = 0$$

$$a_0 = \frac{1}{T_0} \int_{-T_0/4}^{T_0/4} dt = \frac{1}{2}$$

$$a_n = \frac{2}{T_0} \int_{-T_0/4}^{T_0/4} \cos 2\pi \frac{n}{T_0} t dt = \frac{2}{T_0} \frac{\sin 2\pi \frac{n}{T_0} t}{2\pi \frac{n}{T_0}} \Bigg|_{-T_0/4}^{T_0/4}$$

$$= \frac{1}{n\pi} \left[\sin\left(\frac{n\pi}{2}\right) - \sin\left(-\frac{n\pi}{2}\right) \right] = \frac{2}{n\pi} \sin\left(\frac{n\pi}{2}\right)$$

$$= \frac{2}{(2m-1)\pi} \sin\left(\frac{(2m-1)\pi}{2}\right)$$

$$= \frac{2}{(2m-1)\pi} [-\cos(m\pi)]$$

$$= \frac{2}{(2m-1)\pi} [-(-1)^m] = \frac{2}{(2m-1)\pi} (-1)^{m+1}$$

$$= \frac{2}{(2m-1)\pi} (-1)^{m-1}$$

3.2 Amplitude Modulation



◇ Switching Modulator (4/4)

$$g_{T_0}(t) = \frac{1}{2} + \frac{2}{\pi} \sum_{n=1}^{\infty} \frac{(-1)^{n-1}}{2n-1} \cos[2\pi f_c t (2n-1)] \quad (3.11)$$

◇ Substituting Eq. (3.11) in (3.10), $v_2(t)$ consists of two component

◇ A desired AM wave:

$$v_2(t) \approx [A_c \cos(2\pi f_c t) + m(t)] g_{T_0}(t) \quad (3.10)$$

$$\frac{A_c}{2} \left[1 + \frac{4}{\pi A_c} m(t) \right] \cos(2\pi f_c t) \quad , \quad k_a = \frac{4}{\pi A_c}$$

◇ Unwanted component, the spectrum of which contains

- ◇ Delta function at $0, \pm 2f_c, \pm 4f_c$ and so on.
- ◇ Occupy frequency intervals of width $2W$ centered at $0, \pm 3f_c, \pm 5f_c$ and so on, where W is the message bandwidth.
- ◇ Be removed by using a band-pass filter with mid-band frequency f_c and bandwidth $2W$, provide that $f_c > 2W$.

3.2 Amplitude Modulation



- ◇ Envelope Detector (1/2)
 - ◇ The process of demodulation is used to recover the original modulating wave from the incoming modulated wave.
 - ◇ One way to demodulate an AM wave: envelope detector.
 - ◇ Consist of a diode and a resistor-capacitor (RC) filter. (see next page)
 - ◇ The operation of envelope detector:
 - ◇ On a positive half-cycle of the input signal, the diode is forward-biased and the capacitor C charges up rapidly to the peak value of the input signal.
 - ◇ When the input signal falls below this value, the diode becomes reverse-biased and the capacitor C discharges slowly through the load resistor R_L . The discharging process continues until the next positive half-cycle.
 - ◇ When the input signal becomes greater than the voltage across the capacitor, the diode conducts again and the process is repeated.

3.2 Amplitude Modulation



◇ Envelope Detector (2/2)

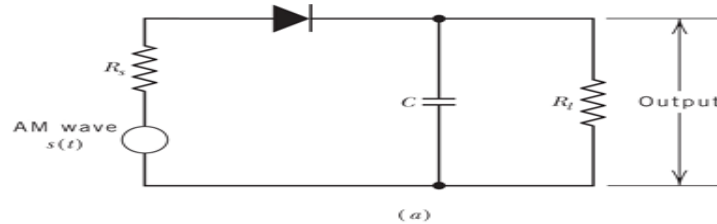

→ Envelope detector circuit diagram, assuming the diode is ideal, having a constant resistance r_f when forward biased and infinite resistance when reverse-biased.

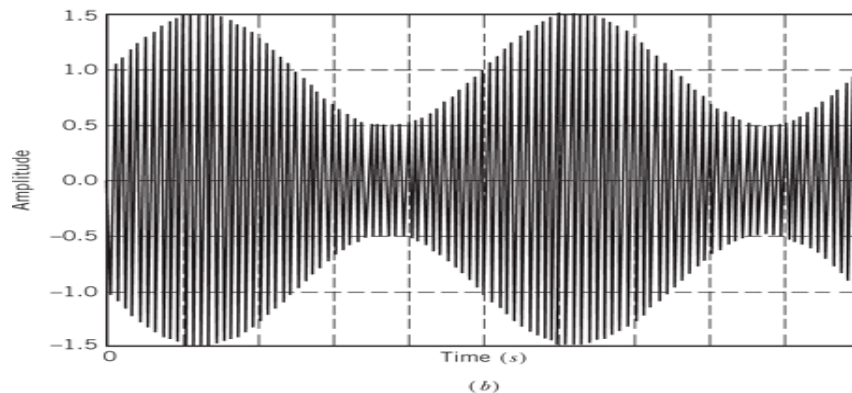

→ A sinusoidal AM wave with 50 percent modulation.

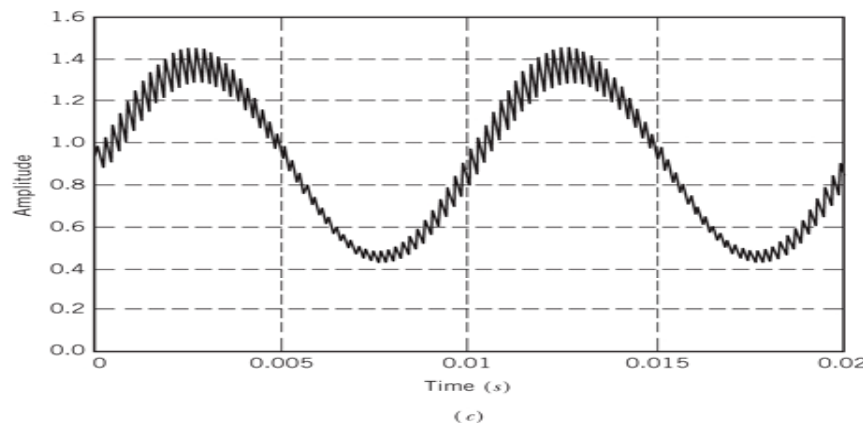

→ Envelope detector output contains a small amount of ripple at the carrier frequency; this ripple is easily removed by the low-pass filter.

Virtues, Limitations, and Modulations of Amplitude Modulation (1/2)



- ◇ AM is the oldest method of performing modulation.
 - ◇ Its biggest virtue is the ease with which it is generated and reversed.
 - ◇ In the transmitter: a switching modulator or a square-law modulator (Problem 3.4).
 - ◇ In the receiver: an envelope detector or a square-law detector (Problem 3.6).
 - ◇ Its system is relatively cheap to build.
 - ◇ The reason that AM radio broadcasting has been popular for so long.
- ◇ *Transmitted power* and *channel bandwidth* are our two primary communication resources. Using Eq. (3.2) suffers from limitations.
 - ◇ *AM is wasteful of power*: The carrier wave $c(t)$ and baseband signal $m(t)$ are independent. The carrier wave represents a waste of power, which means that in AM only a fraction of the total transmitted power is actually affected by $m(t)$.
 - ◇ *AM is wasteful of bandwidth*: The upper and lower sidebands of an AM wave are uniquely related to each other by virtue of their symmetry about the carrier frequency.

$$s(t) = A_c [1 + k_a m(t)] \cos(2\pi f_c t) \quad (3.2)$$

Virtues, Limitations, and Modulations of Amplitude Modulation (2/2)



- ◇ To overcome these limitations, we trade off system complexity for improved utilization of communication resources.
- ◇ Three modified forms of amplitude modulation:
 - ◇ *Double sideband-suppressed carrier (DSB-SC) modulation*, in which the transmitted wave consists of only the upper and lower sidebands.
 - ◇ Transmitted power is saved through the suppression of the carrier. The channel bandwidth requirement is $2W$.
 - ◇ *Vestigial sideband (VSB) modulation*, in which one sideband is passed almost completely and just a trace, or *vestige*, of the other sideband is retained.
 - ◇ The required channel bandwidth is in excess of the message bandwidth by an amount equal to the width of the vestigial sideband.
 - ◇ Suited for the transmission of wideband signals such as television signals.
 - ◇ *Single sideband (SSB) modulation*, in which the modulated wave consists only of the upper sideband or the lower sideband.
 - ◇ Suited for the transmission of voice signals by virtue of the *energy gap* that exists in the spectrum of voice signals between zero and a few hundred hertz.
 - ◇ The minimum transmitted power and minimum channel bandwidth: its principal disadvantage is increased cost and complexity.

Spectra of the various modulated signals

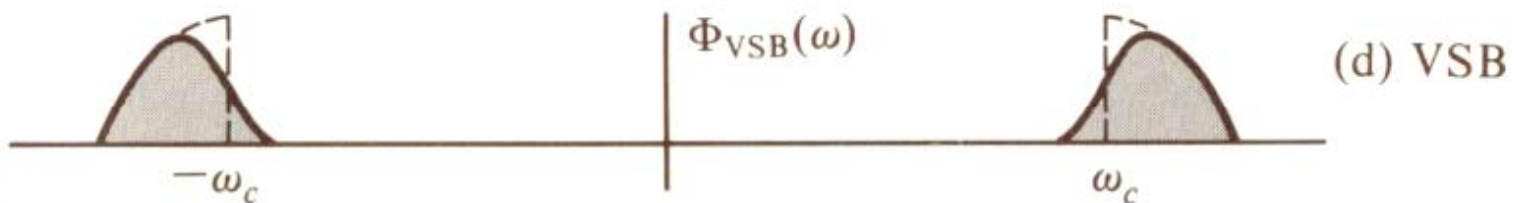
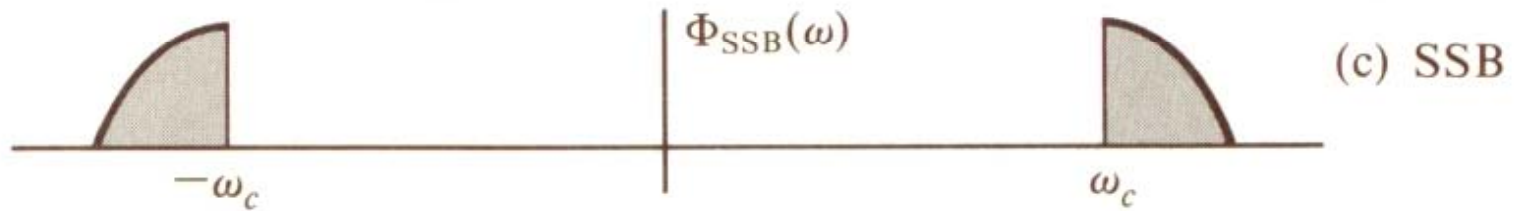
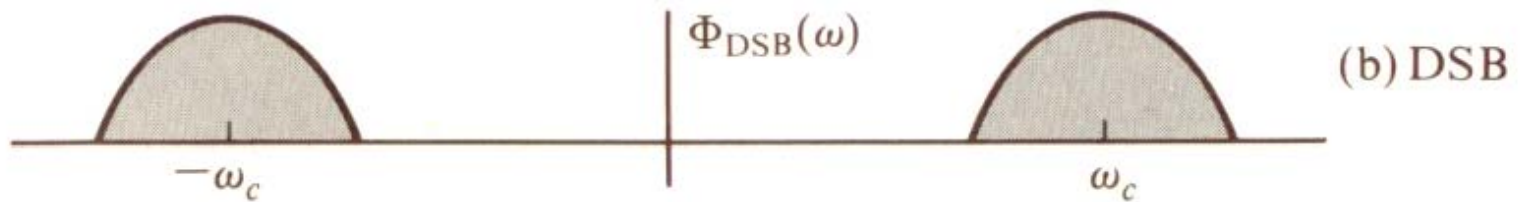
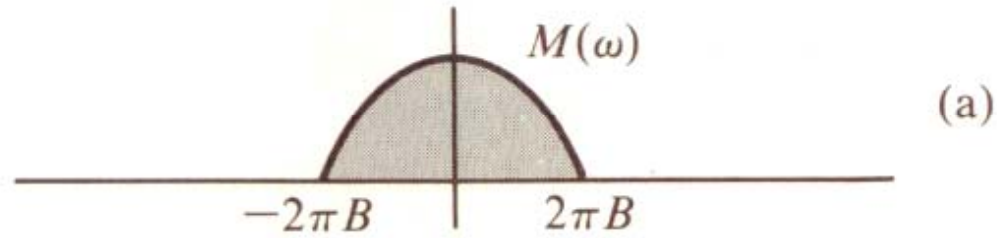

Chapter 3.3

Double Sideband-Suppressed Carrier Modulation



Wireless Information Transmission System Lab.
Institute of Communications Engineering
National Sun Yat-sen University

3.3 Double Sideband-Suppressed Carrier Modulation



◆ *Double sideband-suppressed carrier (DSB-SC) modulation.*

- ◆ Product of the message signal $m(t)$ and the carrier wave $c(t)$:

$$s(t) = c(t)m(t) = A_c \cos(2\pi f_c t) m(t) \quad (3.14)$$

- F*
- ◆ The modulated signal $s(t)$ undergoes a *phase reversal* whenever the message signal $m(t)$ crosses zero.
 - ◆ The envelope of a DSB-SC modulated signal is different from the message signal.

$$S(f) = \frac{1}{2} A_c [M(f - f_c) + M(f + f_c)] \quad (3.15)$$

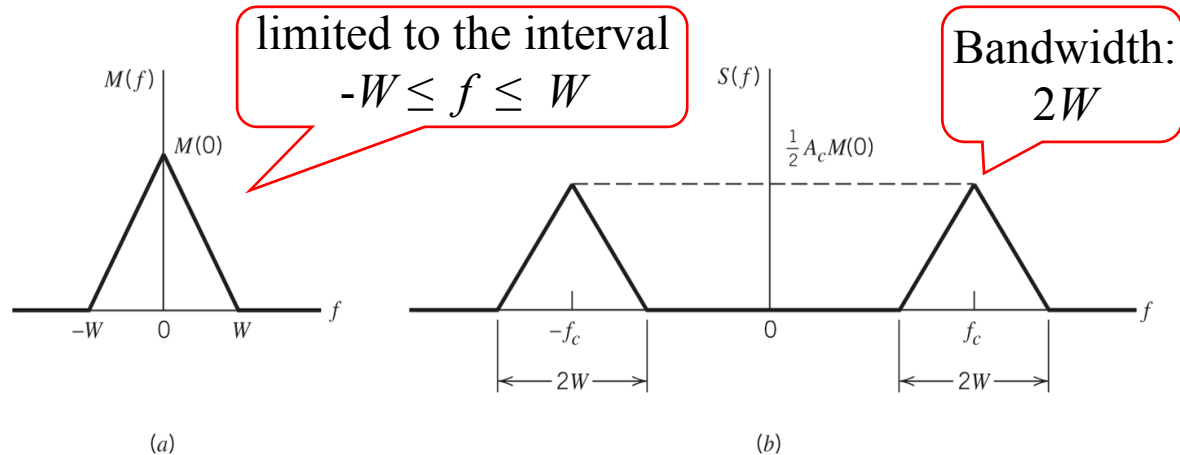
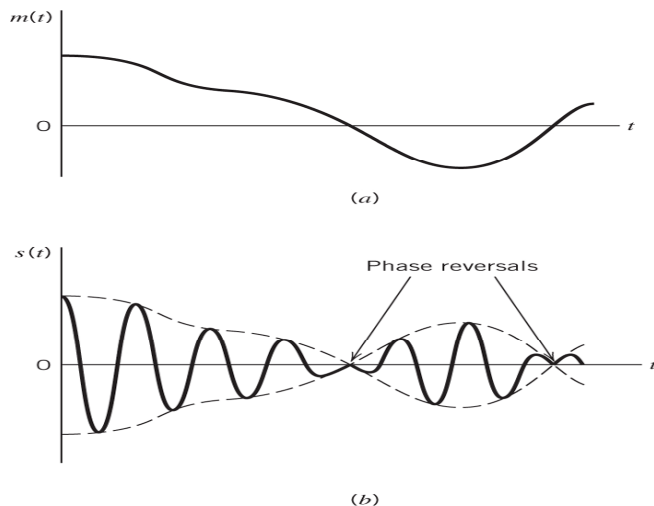

3.3 Double Sideband-Suppressed Carrier Modulation



◇ Ring Modulator (1/4)

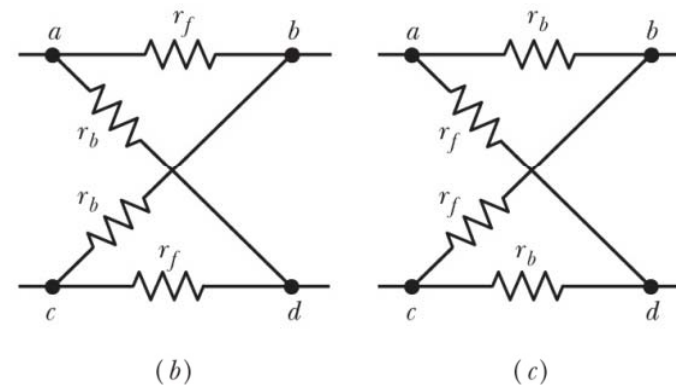
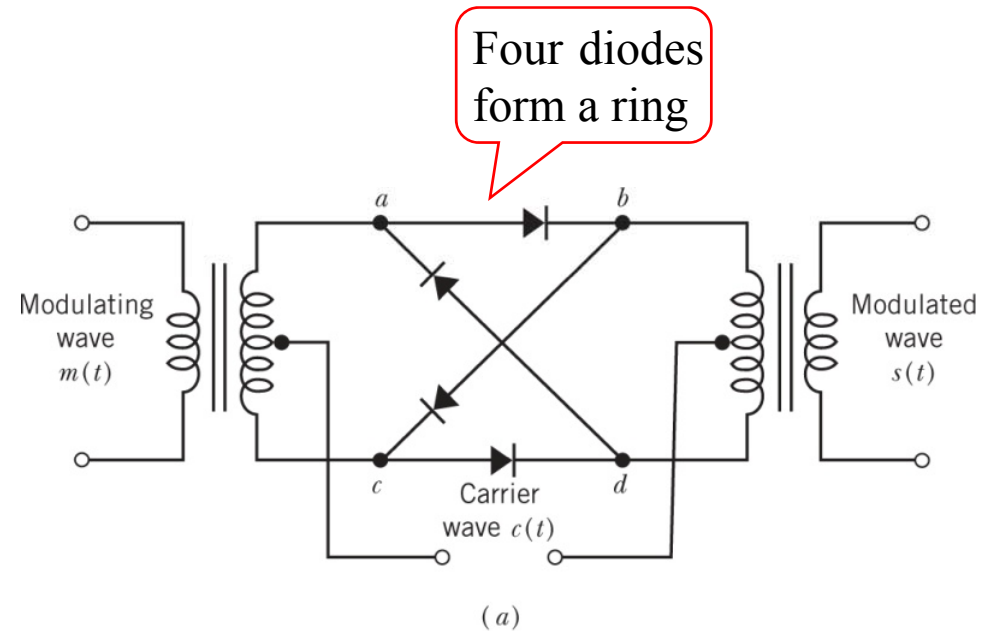
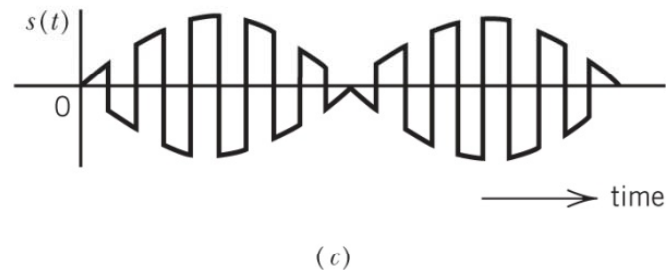
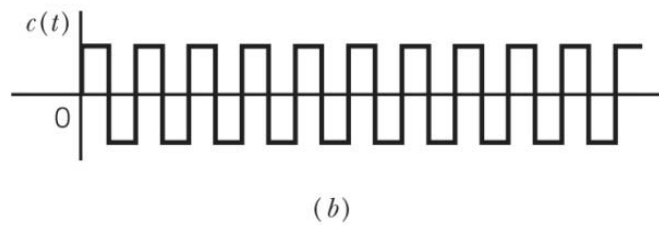
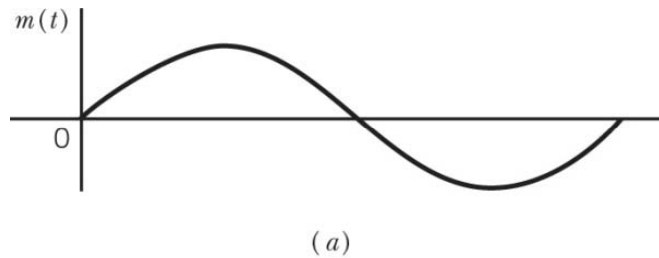

3.3 Double Sideband-Suppressed Carrier Modulation



- ◇ Ring Modulator (2/4)
 - ◇ Ring modulator is one of the most useful product modulator, well suited for generating a DSB-SC wave.
 - ◇ The diodes are controlled by a square-wave carrier $c(t)$ of frequency f_c , which is applied longitudinally by means of two center-tapped transformers.
 - ◇ If the transformers are perfectly balanced and the diodes are identical, there is *no* leakage of the modulation frequency into the modulation output .
 - ◇ The operation of the circuit.
 - ◇ Assuming that the diodes have a constant forward resistance r_f when switched on and a constant backward resistance r_b when switched off. And they switch as the carrier wave $c(t)$ goes through zero.
 - ◇ On one half-cycle of the carrier wave, the outer diodes are switched to their forward resistance r_f and the inner diodes are switched to their backward resistance r_b . On the other half-cycle of the carrier wave, the diodes operate in the opposite condition.

3.3 Double Sideband-Suppressed Carrier Modulation



◇ Ring Modulator (3/4)

- ◇ The output voltage has the same magnitude as the output voltage, but they have opposite polarity.
- ◇ In fact, the ring modulator acts as a commutator.

- ◇ Square-wave carrier $c(t)$ can be represented by a Fourier series:

$$c(t) = \frac{4}{\pi} \sum_{n=1}^{\infty} \frac{(-1)^{n-1}}{2n-1} \cos[2\pi f_c t (2n-1)] \quad (3.16)$$

- ◇ The ring modulator output is therefore

$$s(t) = c(t)m(t) = \frac{4}{\pi} \sum_{n=1}^{\infty} \frac{(-1)^{n-1}}{2n-1} \cos[2\pi f_c t (2n-1)] m(t) \quad (3.17)$$

- ◇ It is sometimes referred to as a double-balanced modulator, because it is balanced with respect to both the baseband signal and the square-wave carrier.

3.3 Double Sideband-Suppressed Carrier Modulation



◇ Ring Modulator (4/4)

- ◇ Assuming that $m(t)$ is limited to the frequency band $-W \leq f \leq W$, the spectrum of the modulator output consists of sidebands around each of the odd harmonics of the square-wave carrier $m(t)$.
- ◇ To prevent sideband overlap $\rightarrow f_c > W$.
- ◇ We can use a band-pass filter of mid-band frequency f_c and bandwidth $2W$ to select the desired pair of sidebands around the carrier frequency f_c .
 - ◇ The circuitry needed for the generation of a DSB-SC modulated wave consists of a ring modulator followed by a band-pass filter.

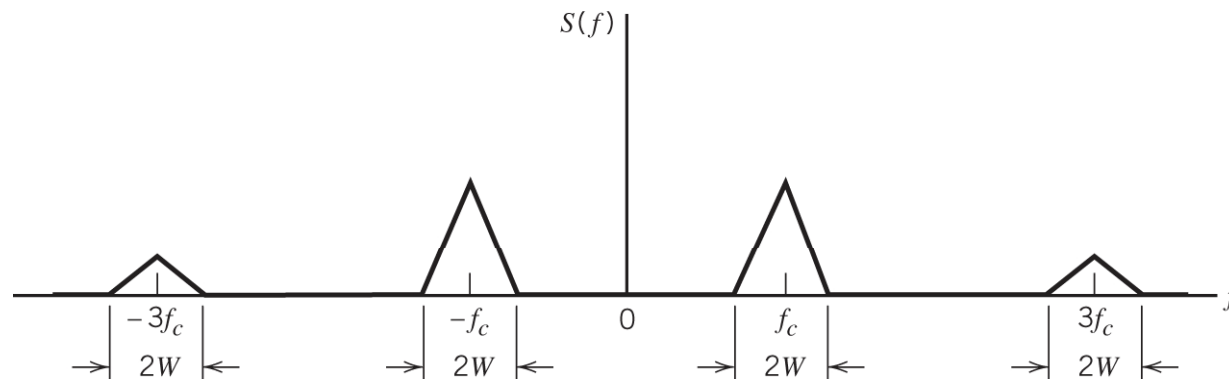

3.3 Double Sideband-Suppressed Carrier Modulation



◇ Coherent Detection (1/4)

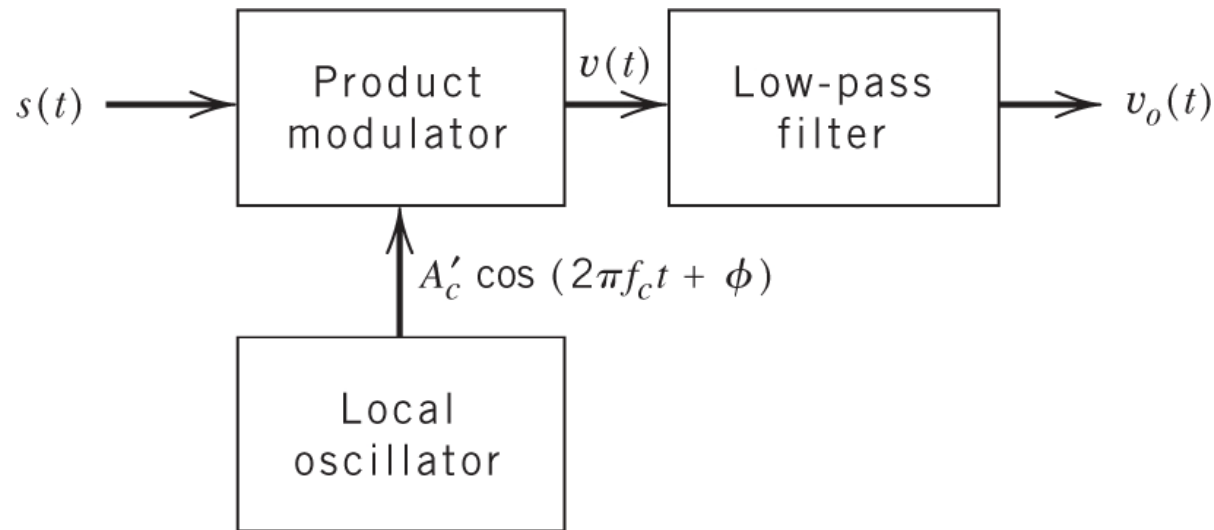

- ◇ It is assumed that the local oscillator signal is exactly coherent or synchronized, in both *frequency and phase*, with carrier wave $c(t)$ used in the product modulator to generate $s(t)$. This method of demodulation is known as coherent detection or synchronous demodulation.

3.3 Double Sideband-Suppressed Carrier Modulation



Coherent Detection (2/4)

For a more general demodulation process, we assume ϕ is an arbitrary phase difference.

$$\begin{aligned}
 v(t) &= A'_c \cos(2\pi f_c t + \phi) s(t) \\
 &= A_c A'_c \cos(2\pi f_c t) \cos(2\pi f_c t + \phi) m(t) \\
 &= \frac{1}{2} A_c A'_c \cos(4\pi f_c t + \phi) m(t) + \frac{1}{2} A_c A'_c \cos \phi m(t)
 \end{aligned}
 \tag{3.18}$$

$s(t) = A_c \cos(2\pi f_c t) m(t)$

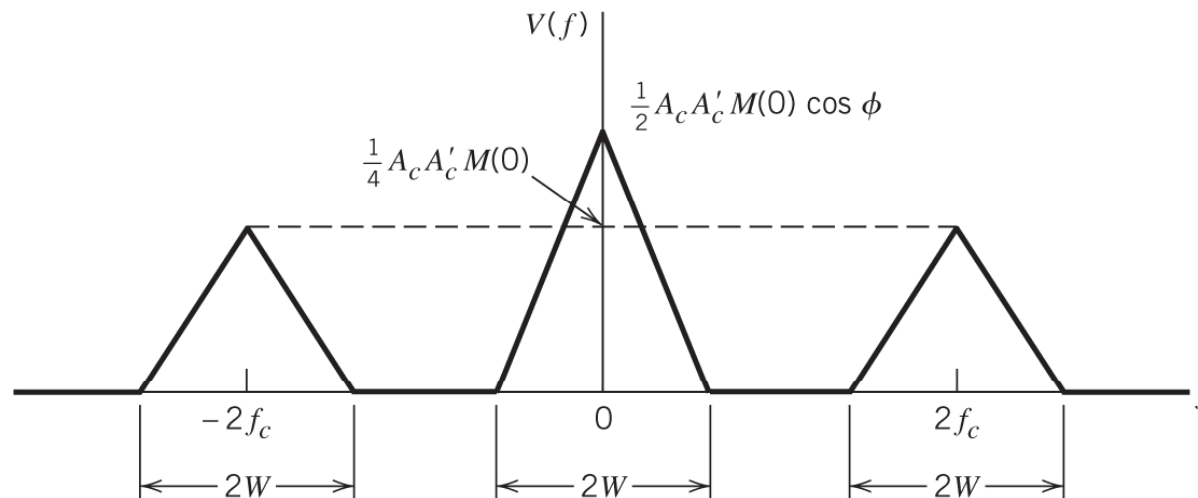

3.3 Double Sideband-Suppressed Carrier Modulation



◇ Coherent Detection (3/4)

- ◇ The first term in Eq.(3.18) is removed by low-pass filter, provided that the cut-off frequency of this filter is greater than W but less than $2f_c - W$. This is satisfied by choosing $f_c > W$.

Therefore:

$$v_o(t) = \frac{1}{2} A_c A_c' \cos \phi m(t) \quad (3.19)$$

- ◇ $v_o(t)$ is proportional to $m(t)$ when the phase error ϕ is a constant. Attenuated by a factor equal to $\cos \phi$.

$$\begin{cases} v_{o_max} = \frac{1}{2} A_c A_c' m(t), & \text{when } \phi=0 \\ v_{o_min} = 0, & \text{when } \phi = \pm \frac{\pi}{2} \end{cases} \quad (\text{quadrature null effect})$$

- ◇ When the phase error ϕ is constant, the detector provides an undistorted version of the original baseband signal $m(t)$.

3.3 Double Sideband-Suppressed Carrier Modulation



◇ Coherent Detection (4/4)

- ◇ In practice, we usually find that the phase error φ varies randomly with time, due to random variations in communication channel. The result is that at the detector output, the multiplying factor $\cos\varphi$ also varies randomly with time, which is obviously undesired.
- ◇ Provision must be made in the system to maintain the local oscillator in the receiver in perfect synchronism, in both frequency and phase, with the carrier wave used to generate the DSB-SC modulated signal in the transmitter.
- ◇ The resulting system complexity is the price that must be paid for suppressing the carrier wave to save transmitter power.

3.3 Double Sideband-Suppressed Carrier Modulation



◆ Costas Receiver (1/2)

- ◆ One method of obtaining a practical synchronous receiver system, suitable for demodulating DSB-SC waves.

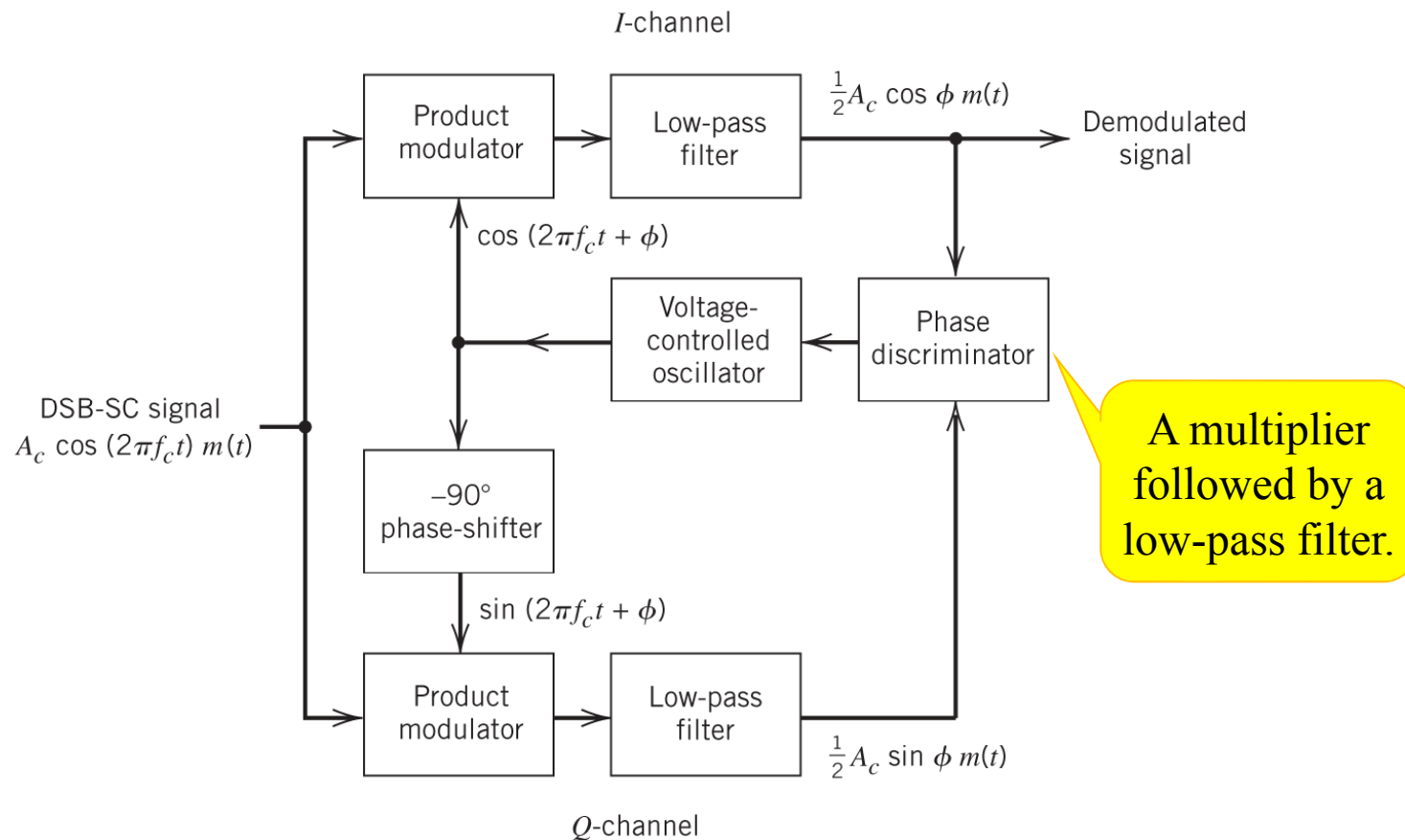

3.3 Double Sideband-Suppressed Carrier Modulation



- ◇ Costas Receiver (2/2)
 - ◇ The frequency of the local oscillator is adjusted to be the same as the carrier frequency f_c , which is assumed known *a priori*.
 - ◇ In the upper path is referred to as the *in-phase coherent detector* or *I-channel*, and that in the lower path is referred to as the *quadrature-phase coherent detector* or *Q-channel*. These two detectors are coupled together to form a negative feedback system designed in such a way as to maintain the local oscillator synchronous with the carrier wave.
 - ◇ By combining the *I*- and *Q*-channel outputs in *phase discriminator* (which consists of a *multiplier* followed by a *low-pass filter*), a dc control signal is obtained that automatically corrects for local phase errors in the *voltage-controlled oscillator* (VCO).

3.3 Double Sideband-Suppressed Carrier Modulation



◇ Outputs of Product Modulator

◇ I-Channel $A_c \cos(2\pi f_c t) m(t) \cos(2\pi f_c t + \phi) = \frac{1}{2} A_c m(t) \{ \cos(4\pi f_c t + \phi) + \cos \phi \}$

◇ Q-Channel $A_c \cos(2\pi f_c t) m(t) \sin(2\pi f_c t + \phi) = \frac{1}{2} A_c m(t) \{ \sin(4\pi f_c t + \phi) + \sin \phi \}$

◇ Outputs of Low-Pass Filter

◇ I-Channel $\frac{1}{2} A_c m(t) \cos \phi$

◇ Q-Channel $\frac{1}{2} A_c m(t) \sin \phi$

◇ Output of Multiplier

$$\left\{ \frac{1}{2} A_c m(t) \cos \phi \right\} \cdot \left\{ \frac{1}{2} A_c m(t) \sin \phi \right\} = \frac{1}{8} A_c^2 [m(t)]^2 \sin 2\phi$$

Chapter 3.4

Quadrature-Carrier Multiplexing



Wireless Information Transmission System Lab.
Institute of Communications Engineering
National Sun Yat-sen University

3.4 Quadrature-Carrier Multiplexing



- Enable two DSB-SC modulated waves to occupy the same channel bandwidth. It is a bandwidth-conservation scheme.

$$s(t) = \underbrace{A_c m_1(t)}_{\text{in-phase component}} \cos(2\pi f_c t) + \underbrace{A_c m_2(t)}_{\text{quadrature-phase component}} \sin(2\pi f_c t) \quad (3.20)$$

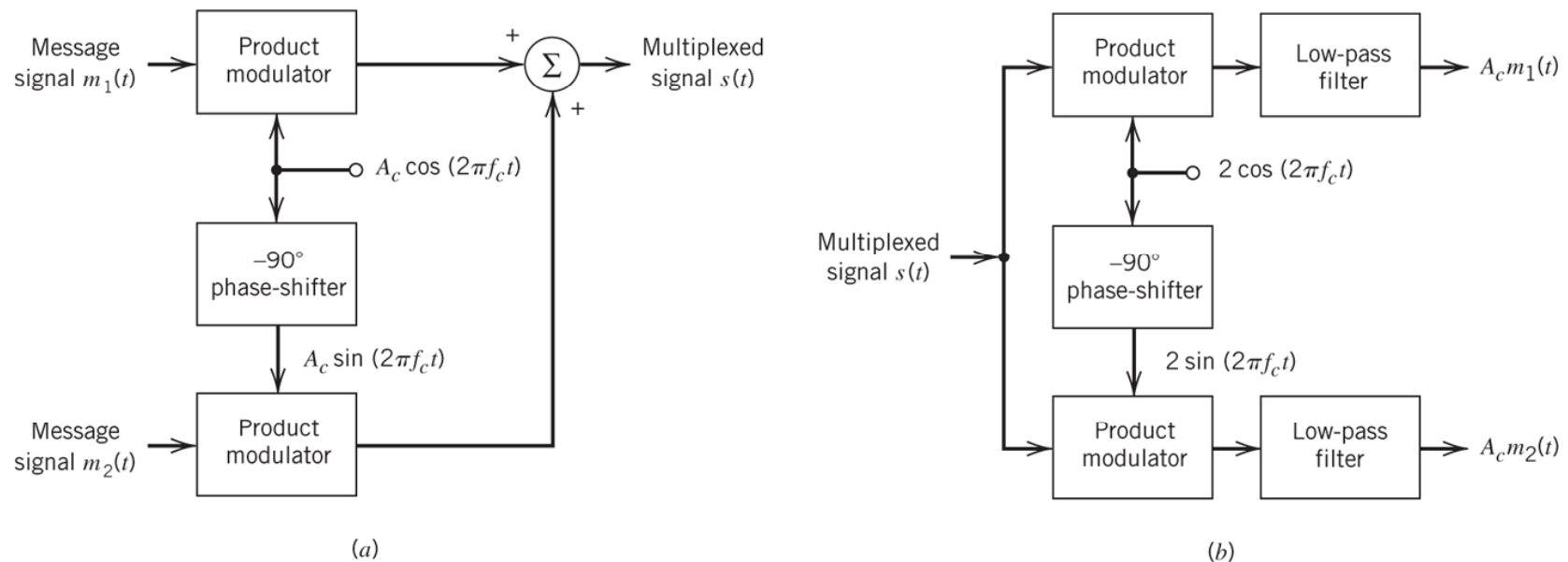

It is important to maintain the correct phase frequency relationship between the local oscillators used in the transmitter and receiver parts of the system.

Chapter 3.5

Single-Sideband and Vestigial-Sideband Methods of Modulation



Wireless Information Transmission System Lab.
Institute of Communications Engineering
National Sun Yat-sen University

3.5 Single-Sideband and Vestigial-Sideband Methods of Modulation



- ◇ With double-sideband modulation, we are transmitting only one such signal and the question that comes to mind is whether the band-pass bandwidth of $2W$ is actually required.

- ◇ In actual fact, it can be shown that due to the symmetry of the DSB signal about the carrier frequency, the same information is transmitted in the *upper* and *lower sidebands*, and only one of the sidebands needs to be transmitted.

- ◇ There are two bandwidth conservation methods:
 - ◇ *Single-sideband* (SSB) *modulation* .
 - ◇ *Vestigial sideband* (VSB) *modulation*.

Single-sideband modulation



- ◇ The generation of a SSB signal is straightforward.
 - ◇ First, generate a double-sideband signal
 - ◇ Then apply an ideal pass-band filter to the result with cutoff frequencies of f_c and $f_c + W$ (or $f_c - W$) for the upper sideband (or lower sideband).
 - ◇ Practically, the approximate construction of an ideal filter is very difficult.

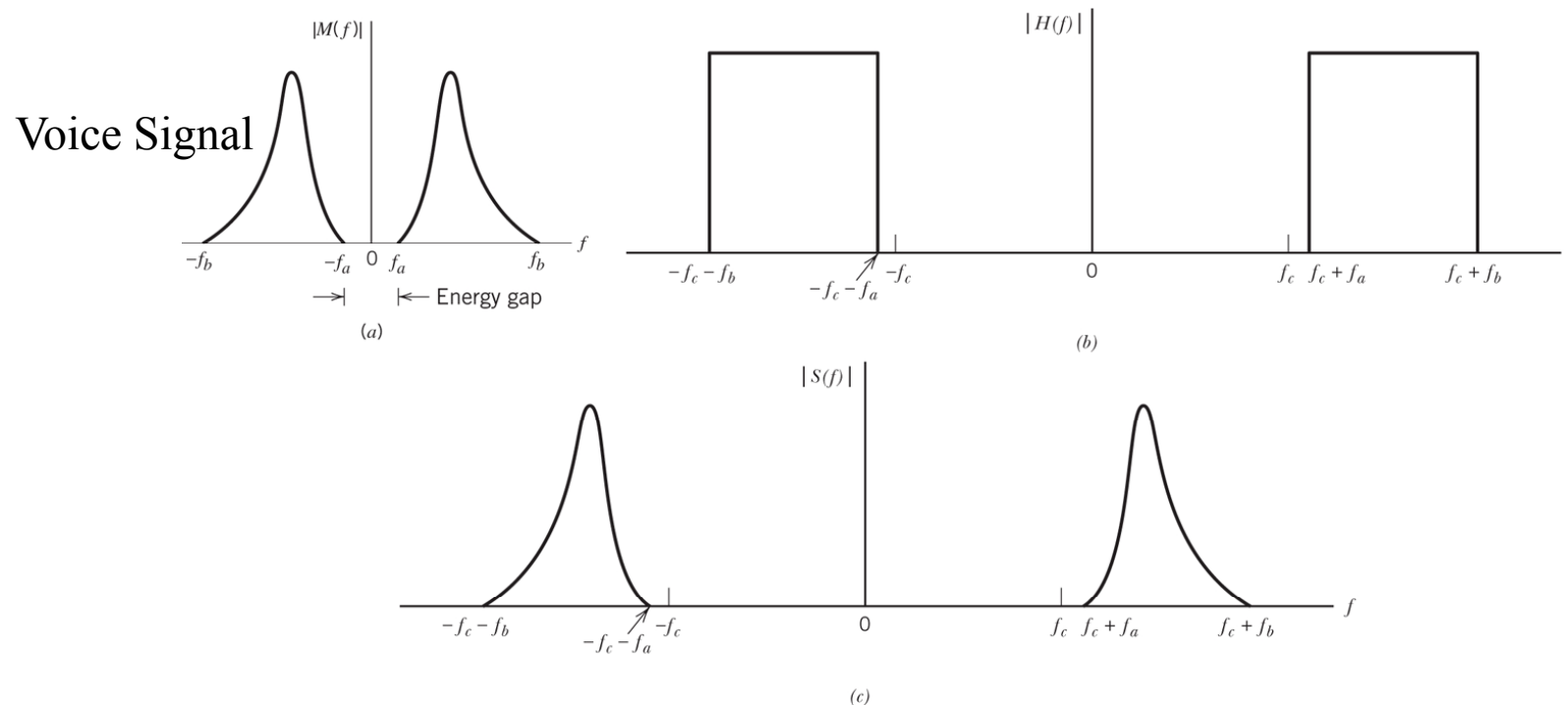

VSB Modulation(1/3)



- ◇ A vestigial-sideband system is a compromise between DSB and SSB. It inherits the advantages of DSB and SSB but avoids their disadvantages.
- ◇ VSB signals are relatively easy to generate and their bandwidth is only slightly (typically 25 percent) greater than that of SSB signals.
- ◇ In VSB, instead of rejecting one sideband completely as in SSB, a gradual cutoff of one sideband is accepted. All of the one sideband is transmitted and a small amount (vestige) of the other sideband is transmitted as well.
- ◇ The filter is allowed to have a nonzero transition band.
- ◇ The roll-off characteristic of the filter is such that the partial suppression of the transmitted sideband in the neighborhood of the carrier is exactly compensated for by the partial transmission of the corresponding part of the suppressed sideband.

VSB Modulation(2/3)



- Our goal is to determine the particular $H(f)$ required to produce a modulated signal $s(t)$ with desired spectral characteristics, such that the original baseband signal $m(t)$ may be recovered from $s(t)$ by coherent detection.

$$S(f) = U(f)H(f)$$

$$= \frac{A_c}{2} [M(f - f_c) + M(f + f_c)]H(f) \quad (3.21)$$

$$m(t) \xrightarrow{F} M(f), \quad u(t) \xrightarrow{F} U(f)$$

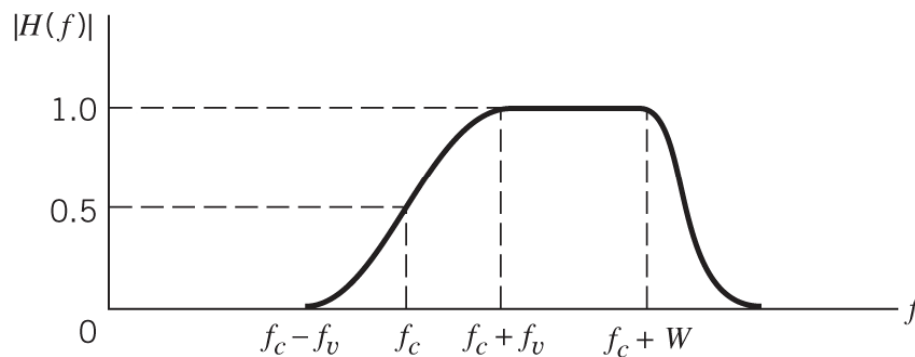
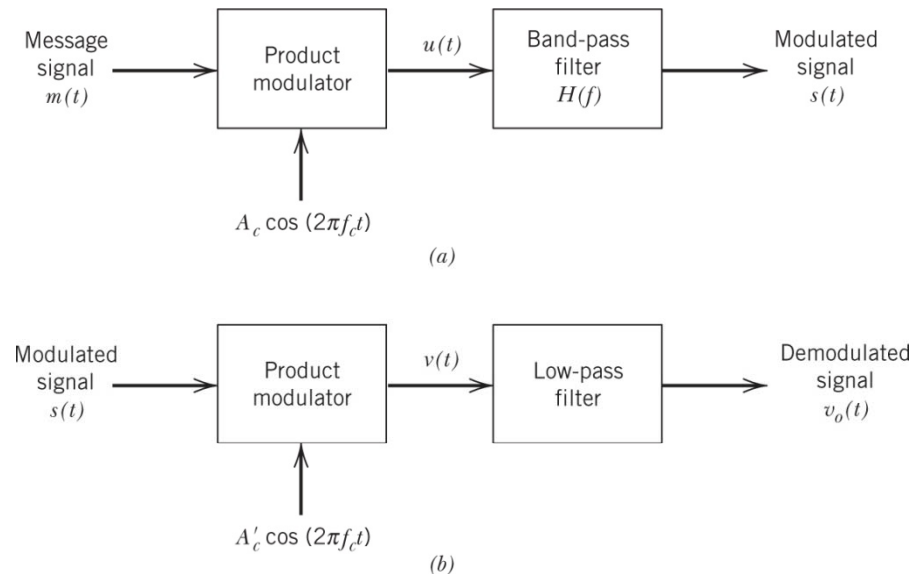

Figure 3.18: Amplitude response of VSB filter; only positive-frequency portion is shown.
 f_v : the width of the vestigial sideband



VSB Modulation(3/3)



$$v(t) = A'_c \cos(2\pi f_c t) s(t)$$

$$V(f) = \frac{A'_c}{2} [S(f - f_c) + S(f + f_c)] \quad (3.22)$$

$$V(f) = \frac{A_c A'_c}{4} M(f) [H(f - f_c) + H(f + f_c)] \quad \text{Combine Eq. (3.21) and (3.22)}$$

$$+ \frac{A_c A'_c}{4} [M(f - 2f_c) H(f - f_c) + M(f + 2f_c) H(f + f_c)] \quad (3.23)$$

$$V_o(f) = \frac{A_c A'_c}{4} M(f) [H(f - f_c) + H(f + f_c)] \quad \text{Low-pass filter} \quad (3.24)$$

- ◆ To obtain baseband signal $m(t)$ at coherent detector output, we require $V_o(f)$ to be a scaled version of $M(f)$. Therefore, we can choose:

$$H(f - f_c) + H(f + f_c) = 1, \quad -W \leq f \leq W \quad (3.26)$$

- ◆ Eq. (3.24) becomes $v_o(t) = \frac{A_c A'_c}{4} m(t)$

baseband $M(f)$ interval:
 $-W \leq f \leq W$

Chapter 3.7

Frequency Translation



Wireless Information Transmission System Lab.
Institute of Communications Engineering
National Sun Yat-sen University

3.7 Frequency Translation



- ◇ The basic operation involved in single-sideband modulation is in fact a form of frequency translation.
 - ◇ SSB modulation is sometimes referred to as frequency changing, mixing, or heterodyning.
- ◇ The mixer consists a product modulator followed by a band-pass filter.
 - ◇ Band-pass filter bandwidth: equal to that of the modulated signal $s_1(t)$ used as input.

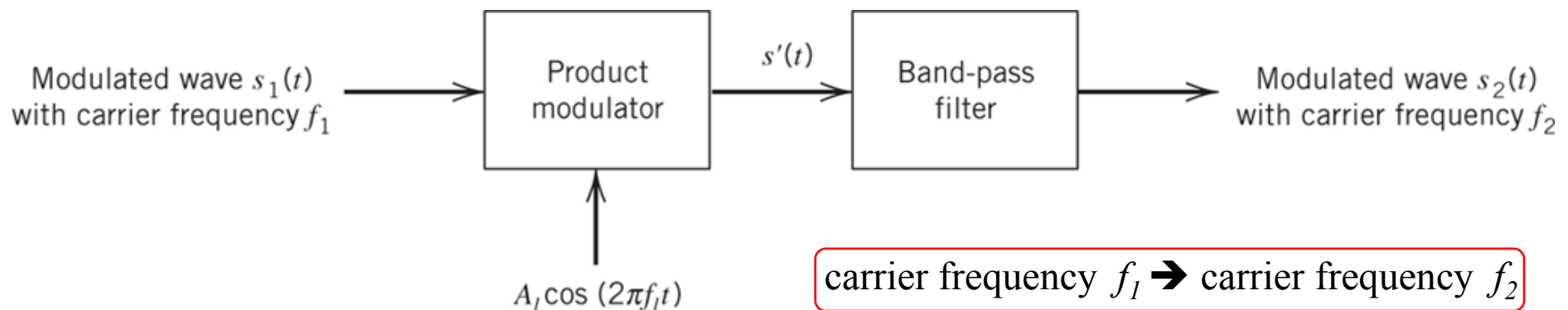

3.7 Frequency Translation



- ◇ Due to frequency translation performed by the *mixer* : We may set

$$\begin{cases} f_2 = f_1 + f_l \\ f_l = f_2 - f_1 \end{cases} \quad \begin{array}{l} \text{assume } f_2 > f_1 \\ \text{translated } \textit{upward} \end{array}$$

$$\text{or} \quad \begin{cases} f_2 = f_1 - f_l \\ f_l = f_1 - f_2 \end{cases} \quad \begin{array}{l} \text{assume } f_1 > f_2 \\ \text{translated } \textit{downward} \end{array}$$

$$\begin{aligned} s_1(t) \times A_l \cos(2\pi f_l t) &= m(t) \cos(2\pi f_1 t) \times A_l \cos(2\pi f_l t) \\ &= \frac{1}{2} A_l m(t) \left[\cos(2\pi(f_1 + f_l)t) + \cos(2\pi(f_1 - f_l)t) \right] \end{aligned}$$

- ◇ The band-pass filter rejects the unwanted frequency and keeps the desired one.
- ◇ Mixing is a linear operation.