

EE302 Exam 1 Review Pac

This is a review packet that will assist you in studying for the first exam. Knowledge of the material covered in the packet and the homework will greatly improve your ability to perform well on the first exam.

Example Problem 1. What is the wavelength of an FM radio station whose frequency is 101.1 MHz?

Example Problem 2. What is the frequency of a signal whose wavelength is 8 cm?

Example Problem 3. To transmit a signal with an antenna, the size of the antenna must be at least a tenth of a wavelength. The old Annapolis VLF transmitter broadcast signals at 24 kHz. What was the approximate size of this antenna?

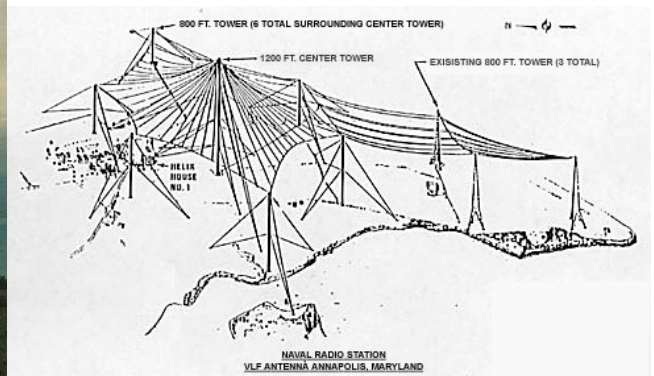

Example Problem 4. The power output of an amplifier is 6 watts (W). The power gain is 80. What is the input power?

Example Problem 5. Three cascaded amplifiers have power gains of 5, 2, and 17. The input power is 40 mW. What is the output power?

Example Problem 6. Consider the three cascaded amplifiers shown below.

- (a) What is the voltage at the output of each stage?
- (b) What is the overall gain of the cascaded multistage system?

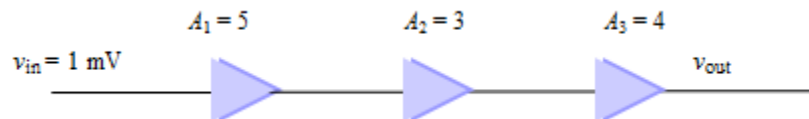

Example Problem 7. Determine the attenuation of the circuit shown below:

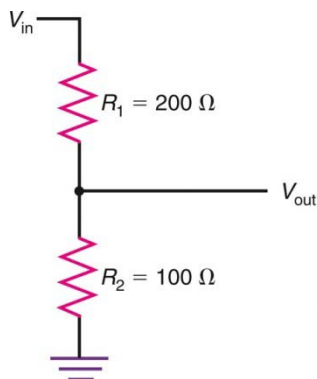

Example Problem 8. For the circuit below, determine:

- (a) The output voltage v_{out}
- (b) The total attenuation

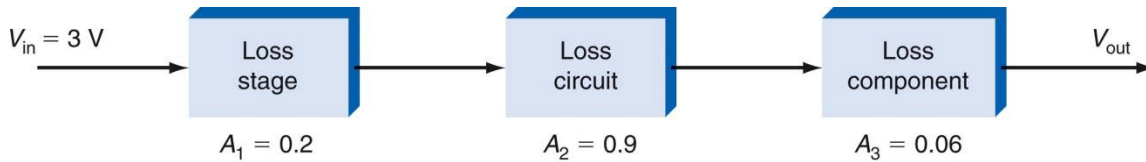

Example Problem 9. The transmitter power of radio station WYPR is 15,500 W and the power that arrives at the car's radio is 10^{-15} W. What is signal attenuation of the channel (free space) expressed in dB?

Example Problem 10. Convert the following from decibels to ratios.

25 dB: $A_P =$

-6 dB: $A_P =$

10 dB: $A_V =$

-6 dB: $A_V =$

Example Problem 11. Express $P_{in} = 2$ watts in decibels (dBW).

Example Problem 12. Express $P_{in} = 2$ watts in decibels (dBm).

Example Problem 13. Express $P_{out} = 12.3$ dBm in watts.

Example Problem 14. The circuit below represents the first three stages of a typical AM or FM receiver. Find the following quantities.

- (a) dB_1 , dB_2 , and dB_3
- (b) dB_T
- (c) P_1 , P_2 , and P_{out} .
- (d) P_{in} (dBm), P_1 (dBm), P_2 (dBm), and P_{out} (dBm).

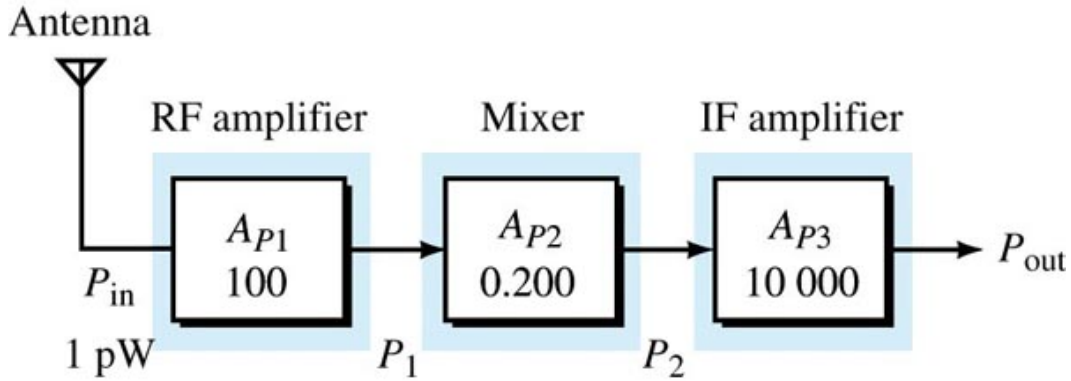

Example Problem 15. A two-stage circuit has an input power of $5 \mu\text{W}$ and an output power of $60 \mu\text{W}$. If the gain of one stage is known to be 18, what is the gain of the second stage?

Example Problem 16. The gains of the individual components in a three-stage circuit are 10 dB, 25 dB and -15 dB. What is the overall gain of the three-stage circuit?

Example Problem 17. Express a power of 6 W in dBm.

Example problem 18. The output power of a circuit is -50 dBm. What is this power in watts?

Example Problem 19. The bandwidth of a receiver with a $75\text{-}\Omega$ input resistance is 6 MHz. If the temperature is 29°C , what is the input thermal noise voltage?

Example Problem 20. The signal power at the input to a receiver is 6.2 nW and the noise power at the input to a receiver is 1.8 nW. Express the SNR as a ratio and as a value in decibels.

Example Problem 21. Answer the following questions about a receiver's noise figure (NF).

- (a) True or False: The NF must be greater than or equal to zero dB.
- (b) True or False: For a receiver, the higher the NF, the better the equipment.
- (c) True or False: The noise at the output of a receiver can be less than the noise at the input.
- (d) In designing a multi-stage receiver, why must extra care be devoted to the design of the first stage?

Example Problem 22. What is wrong with this argument:

A receiver has a power gain of $A_p = 3$. The signal power at the input is 10 W and the noise power at the input is 5 W, so the SNR at the input is $10 / 5 = 2$. Now, since the gain of the receiver is 3 , the signal power at the output of the receiver is $(10 \text{ W})(3) = 30$ W. Similarly, the noise at the output of the receiver is also amplified, and equals $(5 \text{ W})(3) = 15$ W. Therefore the SNR at the output of the receiver is $30 / 15 = 2$ (the same as the input SNR).

Example Problem 23. An amplifier has a measured SNR power ratio of $10,000$ at its input and $5,624$ at its output.

- (a) Calculate the NR.
- (b) Calculate the NF.

Example Problem 24. A receiver has a noise figure of 2.8 dB. The SNR at the input of the receiver is 9.63 dB. What is the SNR at the output of the receiver?

Example Problem 25. A signal has an SNR at the input equal to 8 dB and an SNR at the output equal to 6 dB. What is the noise figure (NF) for this circuit?

Example Problem 26. Consider the two stage circuit below, where the gains and noise ratios are indicated on the figure. Determine:

- (a) The noise figure for stage 1.
- (b) The noise figure for stage 2.
- (c) The noise figure for the overall two-stage combination.

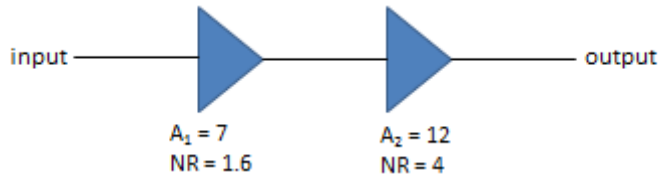

Example Problem 27. The gain of the three stages of an amplifier are 8.45 dB, 10.79 dB, and 20 dB. The noise figures associated with these stages are 2.04 dB, 3.0 dB, and 9.29 dB. What is the overall NR and NF for this cascade of amplifiers?

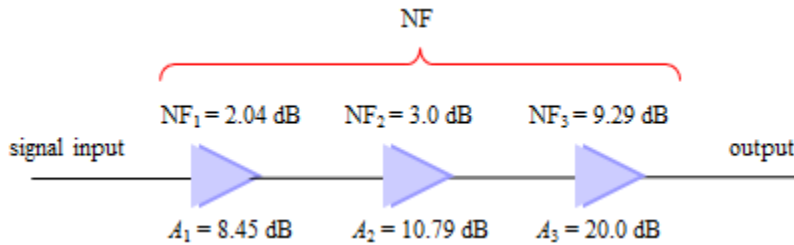

Example Problem 28 Calculate the impedance (Z) of the circuit below at $f = 2$ MHz with the indicated component values

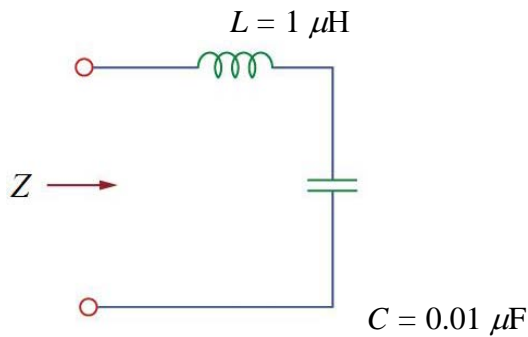

Example Problem 29 Suppose you have a series RLC circuit with a 10 pF capacitor that you want to resonate at 40 MHz. What value of inductance should you use?

Example Problem 30

- (a) What is the resonant frequency f_r of the series RLC circuit below?
- (b) At this frequency, what is the impedance of the circuit?
- (c) At the resonant frequency, what is the phase difference between the voltage across the circuit and the current through it?

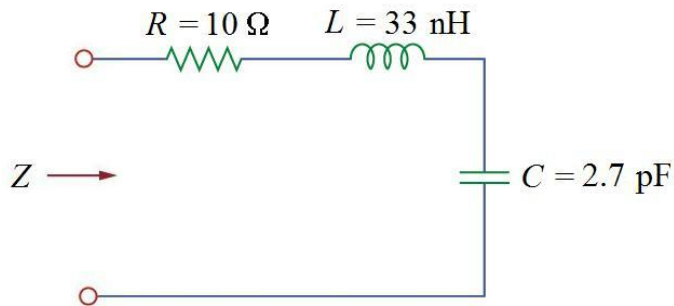

Example Problem 31 What is the bandwidth of a resonant circuit with a frequency of 20 MHz and a Q of 50?

Example Problem 32 For the circuit below, determine the:

- a. Resonant frequency
- b. Quality factor and bandwidth
- c. Half-power frequencies

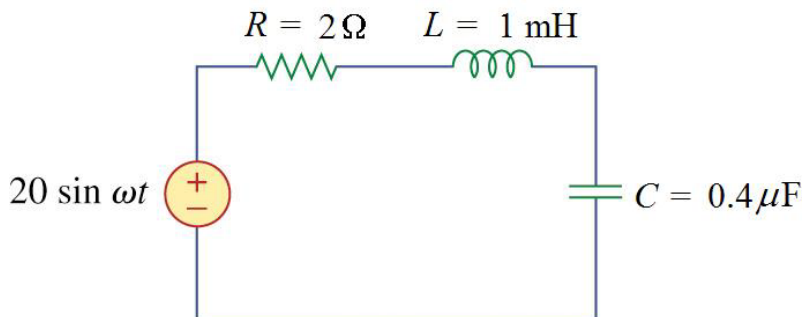

Example Problem 33

What is the cutoff frequency of a single-section RC low-pass filter with $R = 8.2 \text{ k}\Omega$ and $C = 0.0033 \text{ }\mu\text{F}$?

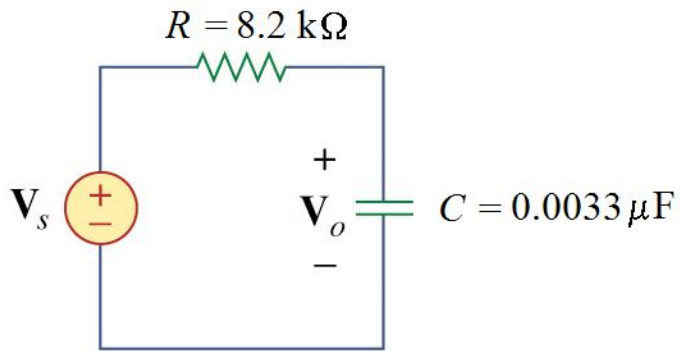

Example Problem 34

What resistor value R will produce a cutoff frequency of 3.4 kHz with a $0.047 \text{ }\mu\text{F}$ capacitor? Is this a high-pass or low-pass filter?

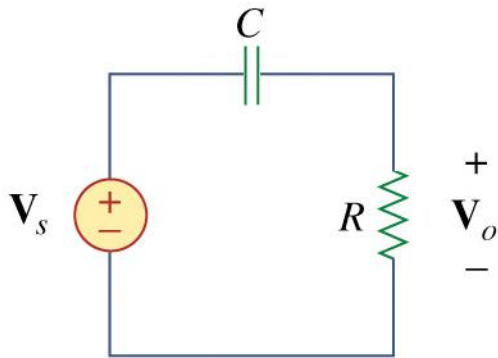

Example Problem 35 The time-domain plot below depicts a sawtooth wave of 1 volt amplitude, generated by using the first 5 harmonics of the Fourier series approximation. Draw the corresponding frequency-domain plot of this signal indicating the frequencies and amplitudes of the components.

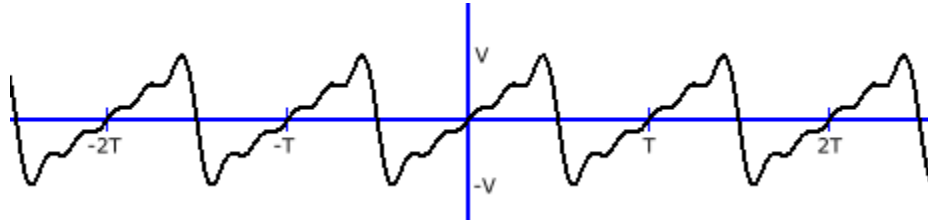

Example Problem 36 The 10 kHz triangle wave with an amplitude of 5 volts is passed through a bandpass filter with a center frequency of $f_c = 50$ kHz and $Q = 10$. Plot the output of the filter in the time and frequency domain.

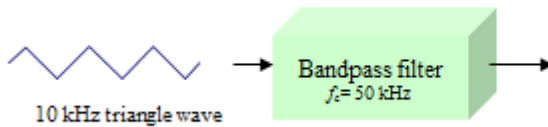

Example Problem 37

If a carrier signal with an amplitude of 9 V is modulated by a sine wave signal with an amplitude of 7.5 V, what is the percentage modulation of the resulting signal?

Example Problem 38 You are looking at an AM signal on an oscilloscope. The maximum value of the modulating wave is 11.8 V and the minimum value is 2.4 V. What is the modulation index?

Example Problem 39 A standard AM broadcast station is allowed to transmit modulating frequencies up to 5 kHz. If the AM station is transmitting on a frequency of 980 kHz, compute the maximum and minimum frequencies of the upper and lower sidebands and the total bandwidth occupied by the AM station.

Example Problem 40. In the picture shown, you measure V_{\max} to be 5.9 volts and V_{\min} to be 1.2 volts.

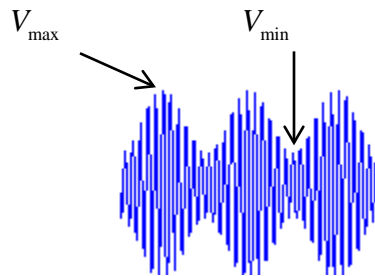

- (a) Determine V_m and V_c (the amplitudes of the modulating waveform and the carrier waveform)
- (b) Determine the modulation index.

Example Problem 41. A 400 Hz tone modulates a 300 kHz carrier. What are the upper and lower sideband frequencies?

Example Problem 42. The carrier of an AM transmitter is 1000 W, and it is modulated 100%. Determine:

- (a) The total power of the AM signal
- (b) The power in each sideband

Example Problem 43. A 70% modulated 250 Watt carrier is used. What is the power in each sideband?

Example Problem 44. An AM transmitter has a carrier power of 30 W. The percentage modulation is 85%. Calculate (a) the total power, and (b) the power in one sideband.

Example Problem 45. The unmodulated carrier current into a 50 Ω antenna is 10 A. What is the total output power if the transmitted AM signal is 85% modulated?

Example Problem 46. One way to measure percentage modulation is to measure both modulated and unmodulated antenna currents. Suppose that the current produced by the carrier alone (no modulation) is 2.2 A. If the modulated signal current is 2.6 A, what is the percentage modulation?

Example Problem 47. An AM signal is 100% modulated (modulation index = 1). The carrier power is 100 W.

- (a) What is the total power in the sidebands?
- (b) What is the total power of the AM signal?
- (c) What is the percentage of power in the sidebands?

Example Problem 48. An AM signal has a carrier power of 500 W and a modulation index of 70%. How much power is in each sideband?

Example Problem 49. An antenna has an impedance of 40Ω . An unmodulated AM signal produces a current of 4.8 A. The modulation is 90%. Determine:

- (a) The carrier power
- (b) The total power.
- (c) The total power in the sidebands

Example Problem 50. Consider the circuit below with a sinusoidal input $v_s(t)$. Assuming an ideal diode, draw the output waveform $v_o(t)$.

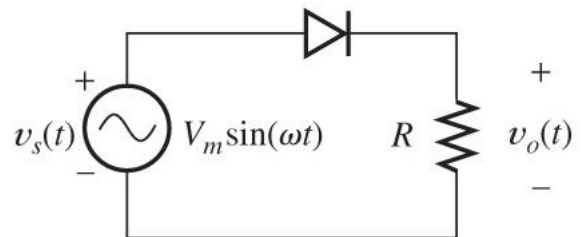
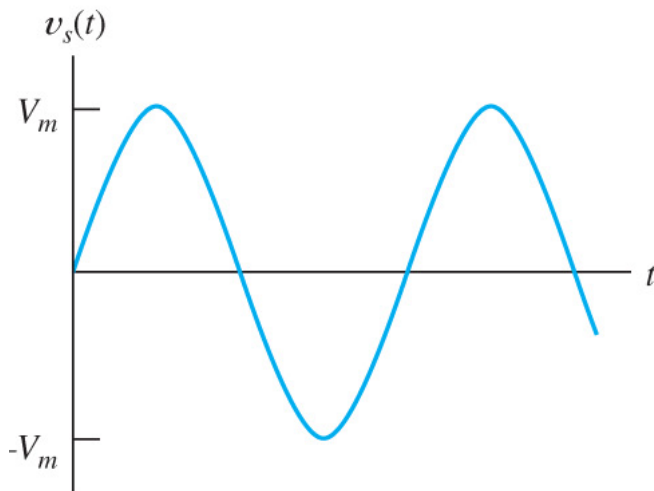

Example Problem 51. Consider the same circuit with an AM input $v_s(t)$. Again, assuming an ideal diode, draw the output waveform $v_o(t)$.

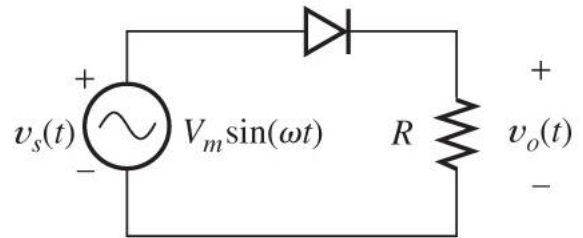
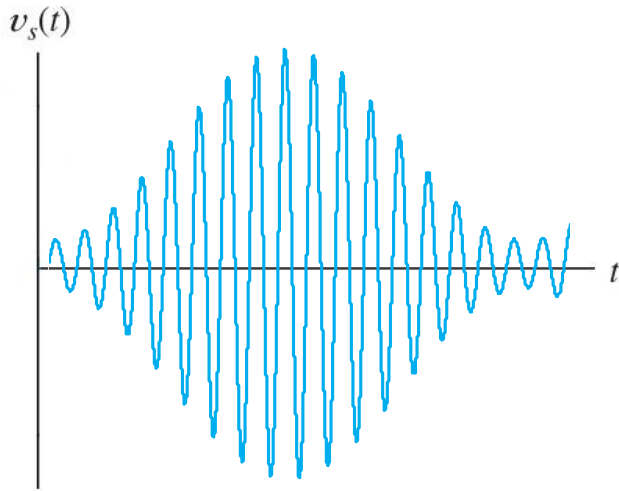

Example Problem 52. A transmitter operates on a carrier frequency of 915 MHz. A ± 1 V square wave modulating signal produces ± 12.5 kHz deviation the carrier. The frequency of the modulating signal is 2 kHz.

- Make a rough sketch of the FM signal.
- If the modulating signal amplitude is doubled, what is the resulting carrier frequency deviation?
- What is the frequency deviation rate of the carrier?

Example Problem 53. Does FM bandwidth increase or decrease with modulation index. Explain.

Example Problem 54. A signal $v_m(t) = \sin(2\pi 1000t)$ frequency modulates a carrier $v_c(t) = \sin(2\pi 500,000t)$. The frequency deviation of the carrier is $f_d = 1000$ Hz.

- a. Determine the modulation index.
- b. The number of sets of significant side frequencies.
- c. Draw the frequency spectrum of the FM signal.

Example problem 55. What is the maximum bandwidth of an FM signal with a deviation of 30 kHz and maximum modulating signal of 5 kHz as determined the following two ways:

- a. Using the table of Bessel functions.
- b. Using Carson's rule.

Example 56. Consider a channel an FM scheme where the maximum deviation allowed is 5 kHz for frequencies up to 3.333 kHz.

- (a) Sketch the spectrum
- (b) Determine the bandwidth of the FM signal from your sketch.
- (c) Use Carlson's rule to determine the bandwidth of a channel

Example 57. Suppose a 5 kHz sine wave is used to FM modulate a 40 MHz carrier. What is the spacing between the sidebands?

Example 58. A 100 MHz carrier is FM modulated by a 5 kHz modulating signal. The maximum deviation in the frequency of the carrier is 12.5 kHz. What is the modulation index?