

# **Electromagnetics I**

Matlab Experiments Manual for

**EE2FH3**

Instructor: Dr. N. K. Nikolova

Prepared by: Dr. M.H. Bakr

Department of Electrical and Computer Engineering  
McMaster University

2012

© COPYRIGHT M.H. Bakr

# ACKNOWLEDGEMENTS

The author would like to acknowledge the help of his colleague Dr. Natalia Nikolova. Dr. Nikolova was very supportive as the previous instructor of EE3FI4. The author had a very useful interaction with her when started to teach EE3FI4.

I would like to thank the Center for Leadership in Learning (CLL) for providing most of the fund for developing this set of MATLAB electromagnetic experiments. CLL has been a main sponsor of innovation in learning in McMaster. It has supported and continues to support many of the initiatives in the Department of Electrical and Computer Engineering.

I would like also to thank my student Chen He for his contribution to this manual. Mr. He worked very hard with me for 4 months in preparing the MATLAB experiments. Our target was to make our electromagnetic courses less abstract and more enjoyable for future students.

Finally, I would to thank my wife and my two beautiful children Omar and Youssef for their support during the preparation of this manual.

Dr. Mohamed Bakr  
Hamilton, September 2006

# Contents

Set 1: Vector Analysis.....	Page 1
Set 2: Surface and Volume Integrals .....	Page 5
Set 3: <b>E</b> Field of Linear Charges.....	Page 14
Set 4: <b>E</b> Field of Surface Charges.....	Page 21
Set 5: Electric Flux Density .....	Page 28
Set 6: Electric Flux through a Surface.....	Page 34
Set 7: Electric Potential .....	Page 40
Set 8: Electric Energy.....	Page 45
Set 9: Electric Current.....	Page 49
Set 10: Image Theory.....	Page 53
Set 11: Boundary Conditions.....	Page 59
Set 12: Capacitance.....	Page 62
Set 13: Analytic Solution of Laplace Equation.....	Page 65
Set 14: Finite Difference Solution of Laplace Equation.....	Page 71
Set 15: Magnetic Field of a Current Sheet.....	Page 78
Set 16: Magnetic Field of a Solenoid.....	Page 84
Set 17: Mutual Inductance.....	Page 89
Set 18: Self Inductance.....	Page 93

## ECE2FH3 Electromagnetics I

Term II, January – April 2012

### MATLAB Examples and Exercises (Set 1)

Prepared by: Dr. M. H. Bakr and C. He

**Example:** Given the points  $M(0.1, -0.2, -0.1)$ ,  $N(-0.2, 0.1, 0.3)$  and  $P(0.4, 0, 0.1)$ , find: a) the vector  $\mathbf{R}_{NM}$ , b) the dot product  $\mathbf{R}_{NM} \cdot \mathbf{R}_{PM}$ , c) the projection of  $\mathbf{R}_{NM}$  on  $\mathbf{R}_{PM}$  and d) the angle between  $\mathbf{R}_{NM}$  and  $\mathbf{R}_{PM}$ . Write a MATLAB program to verify your answer.

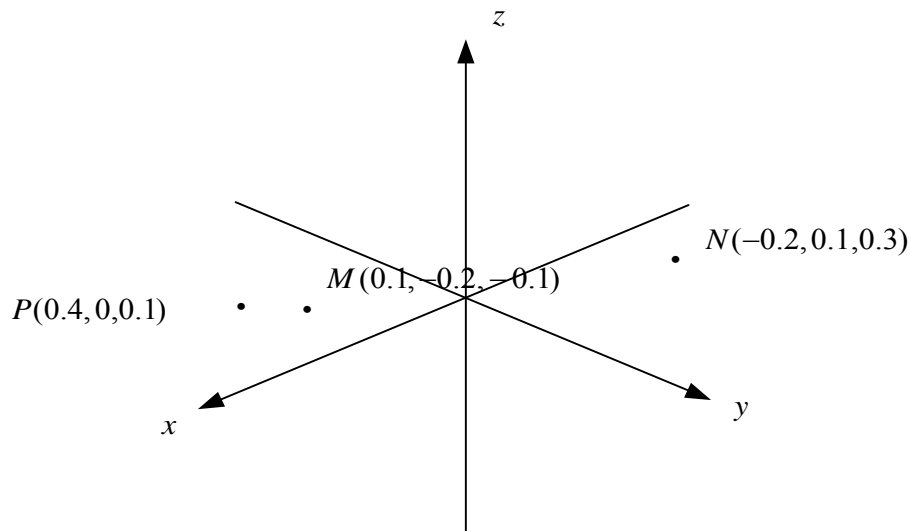


Figure 1.1 The points used in the example of Set 1.

**Analytical Solution:**

$$\begin{aligned} \text{a) } \mathbf{R}_{NM} &= \mathbf{R}_{MO} - \mathbf{R}_{NO} \\ &= (0.1\mathbf{a}_x - 0.2\mathbf{a}_y - 0.1\mathbf{a}_z) - (-0.2\mathbf{a}_x + 0.1\mathbf{a}_y + 0.3\mathbf{a}_z) \\ &= 0.3\mathbf{a}_x - 0.3\mathbf{a}_y - 0.4\mathbf{a}_z \end{aligned}$$

$$\begin{aligned} \text{b) } \mathbf{R}_{PM} &= \mathbf{R}_{MO} - \mathbf{R}_{PO} \\ &= (0.1\mathbf{a}_x - 0.2\mathbf{a}_y - 0.1\mathbf{a}_z) - (0.4\mathbf{a}_x + 0.1\mathbf{a}_z) \\ &= -0.3\mathbf{a}_x - 0.2\mathbf{a}_y - 0.2\mathbf{a}_z \end{aligned}$$

$$\begin{aligned} \mathbf{R}_{NM} \cdot \mathbf{R}_{PM} &= (0.3\mathbf{a}_x - 0.3\mathbf{a}_y - 0.4\mathbf{a}_z) \cdot (-0.3\mathbf{a}_x - 0.2\mathbf{a}_y - 0.2\mathbf{a}_z) \\ &= 0.3 \times (-0.3) + (-0.3) \times (-0.2) + (-0.4) \times (-0.2) \\ &= -0.09 + 0.06 + 0.08 = 0.05 \end{aligned}$$

$$\begin{aligned} \text{c) } \text{proj}_{\mathbf{R}_{PM}} \mathbf{R}_{NM} &= \frac{\mathbf{R}_{NM} \cdot \mathbf{R}_{PM}}{\mathbf{R}_{PM} \cdot \mathbf{R}_{PM}} \mathbf{R}_{PM} \\ &= \frac{0.05}{(-0.3)^2 + (-0.2)^2 + (-0.2)^2} (-0.3\mathbf{a}_x - 0.2\mathbf{a}_y - 0.2\mathbf{a}_z) \\ &= -0.088\mathbf{a}_x - 0.059\mathbf{a}_y - 0.059\mathbf{a}_z \end{aligned}$$

$$\begin{aligned} \text{d) } \cos \theta &= \frac{\mathbf{R}_{NM} \cdot \mathbf{R}_{PM}}{|\mathbf{R}_{NM}| |\mathbf{R}_{PM}|} \\ &= \frac{0.05}{\sqrt{(0.3)^2 + (-0.3)^2 + (-0.4)^2} \sqrt{(-0.3)^2 + (-0.2)^2 + (-0.2)^2}} \\ &= 0.208 \\ \theta &= \cos^{-1} 0.208 = 1.36 \end{aligned}$$

**Definition**

Let  $\mathbf{u}$  and  $\mathbf{v}$  be two nonzero vectors in  $\mathbf{R}^n$ . The cosine of the angle  $\theta$  between these vectors is  $\cos \theta = \frac{\mathbf{u} \cdot \mathbf{v}}{|\mathbf{u}| |\mathbf{v}|}$ ,  $0 \leq \theta \leq \pi$

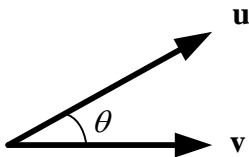


Figure 1.2 The angle between two vectors.

This problem is a direct application to vector algebra. It requires clear understanding of the basic definitions used in vector analysis.

The vector  $\mathbf{R}_{NM}$  can be obtained by subtracting the vector  $\mathbf{R}_{NO}$  from vector  $\mathbf{R}_{MO}$ , where O is the origin.

**Definition**

Let  $\mathbf{u} = (u_1, \dots, u_n)$  and  $\mathbf{v} = (v_1, \dots, v_n)$

be two vectors in  $\mathbf{R}^n$ . The **dot product** of  $\mathbf{u}$  and  $\mathbf{v}$  is defined by

$$\mathbf{u} \cdot \mathbf{v} = u_1 v_1 + \dots + u_n v_n$$

The dot product assigns a real number to each pair of vectors.

**Definition**

The projection of a vector  $\mathbf{v}$  onto a nonzero vector  $\mathbf{u}$  in  $\mathbf{R}^n$  is denoted  $\text{proj}_{\mathbf{u}} \mathbf{v}$  and is defined by

$$\text{proj}_{\mathbf{u}} \mathbf{v} = \frac{\mathbf{v} \cdot \mathbf{u}}{\mathbf{u} \cdot \mathbf{u}} \mathbf{u}$$

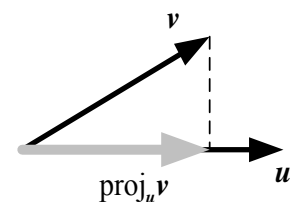


Figure 1.3 The projection of one vector onto another.

## MATLAB Examples and Exercises (Set 1)

## MATLAB SOLUTION:

```
clc; %clear the command line
clear; %remove all previous variables
```

```
O=[0 0 0];%the origin
M=[0.1 -0.2 -0.1];%Point M
N=[-0.2 0.1 0.3];%Point N
P=[0.4 0 0.1];%Point P
```

```
R_MO=M-O;%vector R_MO
R_NO=N-O;%vector R_NO
R_PO=P-O;%vector R_PO
```

```
R_NM=R_MO-R_NO;%vector R_NM
R_PM=R_MO-R_PO;%vector R_PM
```

```
R_PM_dot_R_NM=dot(R_PM,R_NM);%the dot
product of R_PM and R_NM
R_PM_dot_R_PM=dot(R_PM,R_PM);%the dot product of R_PM and R_PM
```

```
Proj_R_NM_ON_R_PM=(R_PM_dot_R_NM/R_PM_dot_R_PM)*R_PM;%the projection of R_NM ON R_PM
```

```
Mag_R_NM=norm(R_NM);%the magnitude of R_NM
Mag_R_PM=norm(R_PM);%the magnitude of R_PM
```

```
COS_theta=R_PM_dot_R_NM/(Mag_R_PM*Mag_R_NM);%this is the cosine value of the angle
between R_PM and R_NM
theta=acos(COS_theta);%the angle between R_PM and R_NM
```

```
R_NM =
    0.3000 -0.3000 -0.4000
```

```
R_PM_dot_R_NM =
    0.0500
```

```
Proj_R_NM_ON_R_PM =
   -0.0882 -0.0588 -0.0588
```

```
theta =
    1.3613
```

```
>>
```

To declare and initialize vectors or points in a MATLAB program, we simply type  $N=[-0.2 \ 0.1 \ 0.3]$  for example, and MATLAB program will read this as  $N=-0.2a_1+0.1a_2+0.3a_3$ , a 3-D vector. If we type  $N=[-0.2 \ 0.1]$  MATLAB program will read this as  $N=-0.2a_1+0.1a_2$ , a 2-D vector.

Some of the functions are already available in the MATLAB library so we just need to call them. For those not included in the library, the variables are utilized in the formulas we derived in the analytical part.

The running result is shown in the left, note that  $\theta$  is given in radians here.

**Exercise:** Given the vectors  $\mathbf{R}_1 = a_x + 2a_y + 3a_z$ ,  $\mathbf{R}_2 = 3a_x + 2a_y + a_z$ . Find a) the dot product  $\mathbf{R}_1 \cdot \mathbf{R}_2$ , b) the projection of  $\mathbf{R}_1$  on  $\mathbf{R}_2$ , c) the angle between  $\mathbf{R}_1$  and  $\mathbf{R}_2$ . Write a MATLAB program to verify your answer.

## ECE2FH3 Electromagnetics I

Term II, January – April 2012

### MATLAB Examples and Exercises (Set 2)

Prepared by: Dr. M. H. Bakr and C. He

**Example:** The open surfaces  $\rho = 2.0$  m and  $\rho = 4.0$  m,  $z = 3.0$  m and  $z = 5.0$  m, and  $\phi = 20^\circ$  and  $\phi = 60^\circ$  identify a closed surface. Find a) the enclosed volume, b) the total area of the enclosed surface. Write a MATLAB program to verify your answers.

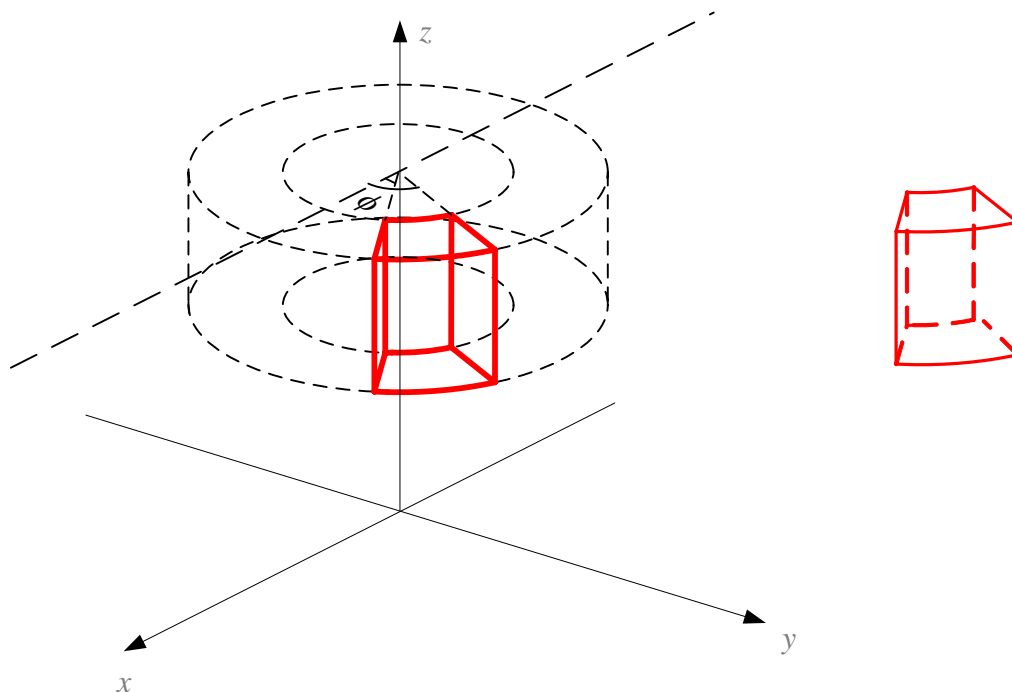


Figure 2.1 The enclosed volume for the example of Set 2.



**Analytical Solution:**

The closed surface in this problem is shown in Figure 2.1 and Figure 2.2. To find the volume  $v$  of a closed surface we first find out  $dv$ , the volume element. In cylindrical coordinates,  $dv$  is given by  $dv = \rho d\phi d\rho dz$  as shown in Figure 2.2. Once we get the expression of  $dv$ , we integrate  $dv$  over the entire volume.

$$dv = \rho d\phi d\rho dz$$

$$v = \iiint_v dv$$

$$= \iiint_v \rho d\phi d\rho dz$$

$$= \int_{\rho=2}^{\rho=4} \int_{\phi=20^\circ}^{\phi=60^\circ} \int_{z=3}^{z=5} \rho d\phi d\rho dz$$

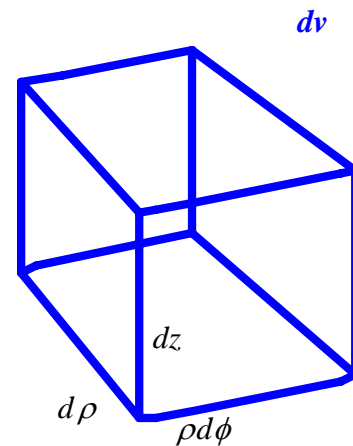
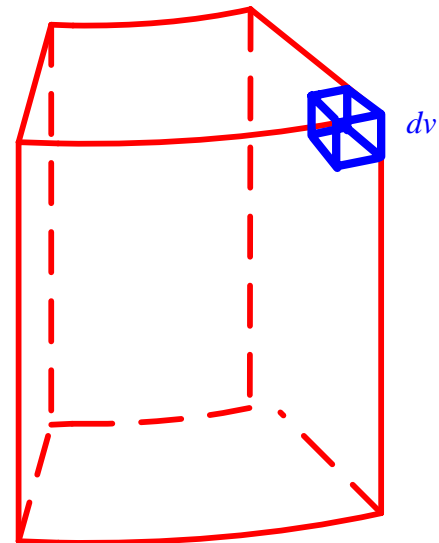
$$= \int_{\rho=2}^{\rho=4} \rho d\rho \int_{\phi=\frac{20}{180}\pi}^{\phi=\frac{60}{180}\pi} d\phi \int_{z=3}^{z=5} dz$$

$$= \frac{1}{2} \rho^2 \Big|_{\rho=2}^{\rho=4} \times \phi \Big|_{\phi=\frac{2}{18}\pi}^{\phi=\frac{6}{18}\pi} \times z \Big|_{z=3}^{z=5}$$

$$= \frac{1}{2} \times (4^2 - 2^2) \times \left(\frac{6}{18}\pi - \frac{2}{18}\pi\right) \times (5 - 3)$$

$$= \frac{8}{3} \pi = 8.378$$

When evaluating an integral, we have to convert degree to radian for all angles, otherwise this will result in a wrong value for the integral.



**Figure 2.2. The unit volume.**

The area of the closed surface is given by

$$S_{\text{enclosed}} = S_1 + S_2 + S_3 + S_4 + S_5 + S_6$$

We need to find  $dS_1$ ,  $dS_2$ , ..., and  $dS_6$  and to integrate them over their boundary. It is obvious that  $S_3 = S_4$  and  $S_5 = S_6$ . The surfaces  $S_1$  and  $S_2$  have similar shapes as we can see from the following expressions,

$$dS_1 = \rho d\phi dz \Big|_{\rho=2} = 2 d\phi dz \quad \text{and}$$

$$dS_2 = \rho d\phi dz \Big|_{\rho=4} = 4 d\phi dz$$

The steps to evaluate the area of each surface are executed as follows:

$$dS_1 = \rho d\phi dz$$

$$S_1 = \iint_S dS_1$$

$$= \iint_S \rho d\phi dz$$

$$= 2 \int_{\phi=\frac{20}{180}\pi}^{\phi=\frac{60}{180}\pi} d\phi \int_{z=3}^{z=5} dz$$

$$= 2 \phi \Big|_{\phi=\frac{2}{18}\pi}^{\phi=\frac{6}{18}\pi} \times z \Big|_{z=3}^{z=5}$$

$$= 2 \times \left( \frac{6}{18}\pi - \frac{2}{18}\pi \right) \times (5-3)$$

$$= \frac{8}{9}\pi \text{ m}^2$$

$$S_2 = \iint_S dS_2$$

$$= \iint_S \rho d\phi dz$$

$$= 4 \int_{\phi=\frac{20}{180}\pi}^{\phi=\frac{60}{180}\pi} d\phi \int_{z=3}^{z=5} dz$$

$$= 4 \phi \Big|_{\phi=\frac{2}{18}\pi}^{\phi=\frac{6}{18}\pi} \times z \Big|_{z=3}^{z=5}$$

$$= 4 \times \left( \frac{6}{18}\pi - \frac{2}{18}\pi \right) \times (5-3)$$

$$= \frac{16}{9}\pi \text{ m}^2$$

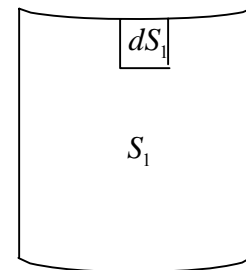
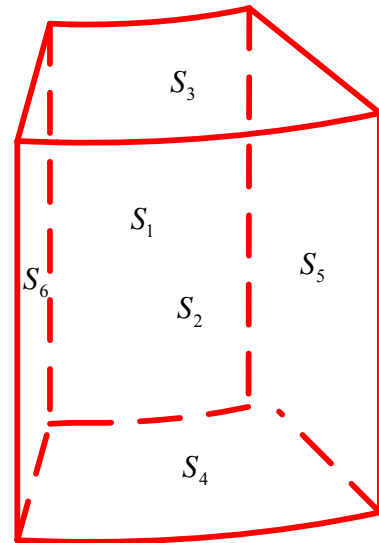


Figure 2.3 The closed surface.

$$dS_3 = \rho d\phi d\rho$$

$$S_3 = \iint_S dS_3$$

$$= \iint_S \rho d\phi d\rho$$

$$= \int_{\rho=2}^{\rho=4} \rho d\rho \int_{\phi=\frac{2}{18}\pi}^{\phi=\frac{6}{18}\pi} d\phi$$

$$= \frac{1}{2} \rho^2 \Big|_{\rho=2}^{\rho=4} \times \phi \Big|_{\phi=\frac{2}{18}\pi}^{\phi=\frac{6}{18}\pi}$$

$$= \frac{1}{2} \times (4^2 - 2^2) \times \left( \frac{6}{18}\pi - \frac{2}{18}\pi \right)$$

$$= \frac{4}{3} \pi \text{ m}^2$$

$$dS_5 = d\rho dz$$

$$S_5 = \iint_S dS_5$$

$$= \iint_S d\rho dz$$

$$= \int_{\rho=2}^{\rho=4} d\rho \int_{z=3}^{z=5} dz$$

$$= \rho \Big|_{\rho=2}^{\rho=4} \times z \Big|_{z=3}^{z=5}$$

$$= (4 - 2) \times (5 - 3)$$

$$= 4 \text{ m}^2$$

$$S_{\text{closed}} = S_1 + S_2 + 2S_3 + 2S_5$$

$$= \frac{8}{9}\pi + \frac{16}{9}\pi + 2 \times \frac{4}{3}\pi + 2 \times$$

$$= 24.755 \text{ m}^2$$

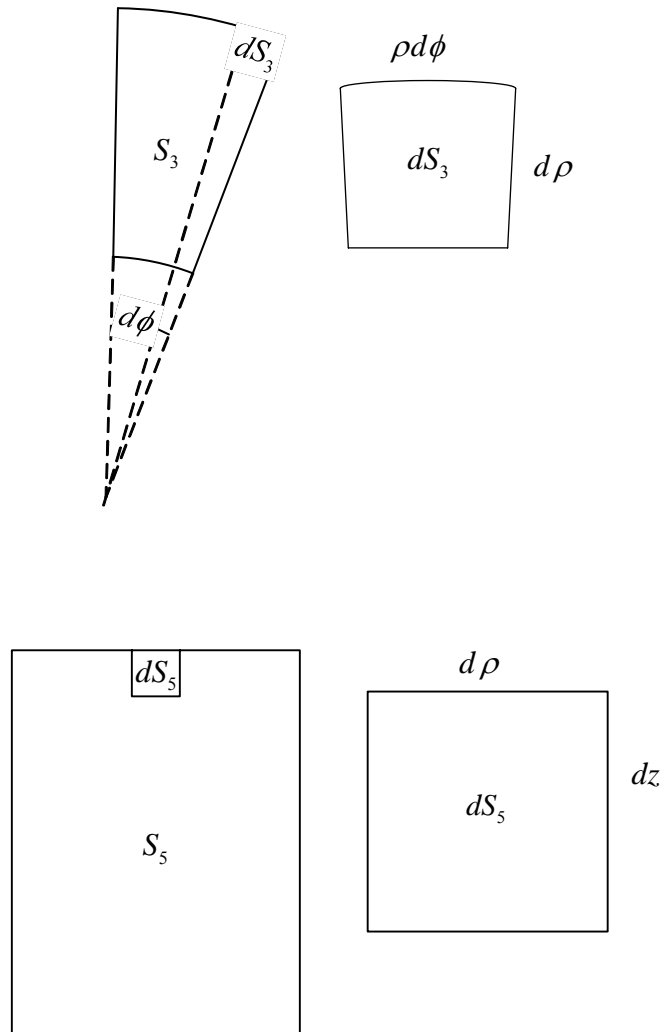


Figure 2.4 The surfaces  $S_3$  and  $S_5$  and their incremental elements.

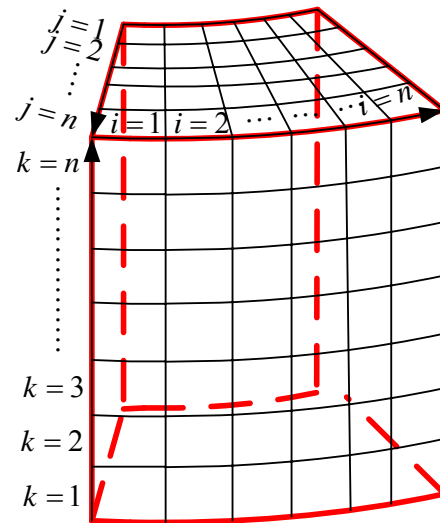
**MATLAB SOLUTION:**

As shown in the figure to the right, the approximate value of the enclosed volume is

$$v \doteq \sum_{k=1}^p \sum_{j=1}^m \sum_{i=1}^n \Delta v_{i,j,k} = \sum_{k=1}^p \sum_{j=1}^m \sum_{i=1}^n (\rho_{i,j,k} \Delta \phi) \times (\Delta \rho) \times (\Delta z)$$

We write a MATLAB program to evaluate this expression. To do this, our program evaluates all element volumes  $\Delta v_{i,j,k}$ , and increase the total volume by  $\Delta v_{i,j,k}$  each time.

We cover all elements  $\Delta v_{i,j,k}$  through 3 loops with counters  $i$  in the inner loop,  $j$  in the middle loop and  $k$  in the outer loop. The approach used to evaluate the surfaces is similar to that of the volume. The MATLAB code is shown in the next page.



**Figure 2.5** The discretized volume.

**MATLAB code:**

```
clc; %clear the command line
clear; %remove all previous variables

V=0;%initialize volume of the closed surface to 0
S1=0;%initialize the area of S1 to 0
S2=0;%initialize the area of S1 to 0
S3=0;%initialize the area of S1 to 0
S4=0;%initialize the area of S1 to 0
S5=0;%initialize the area of S1 to 0
S6=0;%initialize the area of S1 to 0
rho=2;%initialize rho to the its lower boundary
z=3;%initialize z to the its lower boundary
phi=pi/9;%initialize phi to the its lower boundary

Number_of_rho_Steps=100; %initialize the rho discretization
Number_of_phi_Steps=100;%initialize the phi discretization
Number_of_z_Steps=100;%initialize the z discretization

drho=(4-2)/Number_of_rho_Steps;%The rho increment
dphi=(pi/3-pi/9)/Number_of_phi_Steps;%The phi increment
dz=(5-3)/Number_of_z_Steps;%The z increment

%%the following routine calculates the volume of the enclosed surface
for k=1:Number_of_z_Steps
    for j=1:Number_of_rho_Steps
        for i=1:Number_of_phi_Steps
            V=V+rho*dphi*drho*dz;%add contribution to the volume
        end
        rho=rho+drho;%rho increases each time when z has been traveled from its lower boundary to its upper
boundary
    end
    rho=2;%reset rho to its lower boundary
end
```

```
%%the following routine calculates the area of S1 and S2
rho1=2;%radius of S1
rho2=4;%radius of s2
for k=1:Number_of_z_Steps
    for i=1:Number_of_phi_Steps
        S1=S1+rho1*dphi*dz;%get contribution to the the area of S1
        S2=S2+rho2*dphi*dz;%get contribution to the the area of S2
    end
end
%%the following routing calculate the area of S3 and S4
rho=2;%reset rho to it's lower boundaty
for j=1:Number_of_rho_Steps
    for i=1:Number_of_phi_Steps
        S3=S3+rho*dphi*drho;%get contribution to the the area of S3
    end
    rho=rho+drho;%p increases each time when phi has been traveled from it's lower boundary to it's upper
boundary
end
S4=S3;%the area of S4 is equal to the area of S3

%%the following routing calculate the area of S5 and S6
for k=1:Number_of_z_Steps
    for j=1:Number_of_rho_Steps
        S5=S5+dz*drho;%get contribution to the the area of S3
    end
end
S6=S5;%the area of S6 is equal to the area of S6
S=S1+S2+S3+S4+S5+S6;%the area of the enclosed surface
```

**Running Result**

Command Window

&gt;&gt; V

V =

8.3497

&gt;&gt; S

S =

24.7272

&gt;&gt;

By comparing, we see that the result of our analytical solution is close to the result of our MATLAB solution.

**Exercise:** The surfaces  $r = 0$  and  $r = 2$ ,  $\phi = 45^\circ$ ,  $\phi = 90^\circ$ ,  $\theta = 45^\circ$  and  $\theta = 90^\circ$  define a closed surface. Find the enclosed volume and the area of the closed surface  $S$ . Write a MATLAB program to verify your answer.

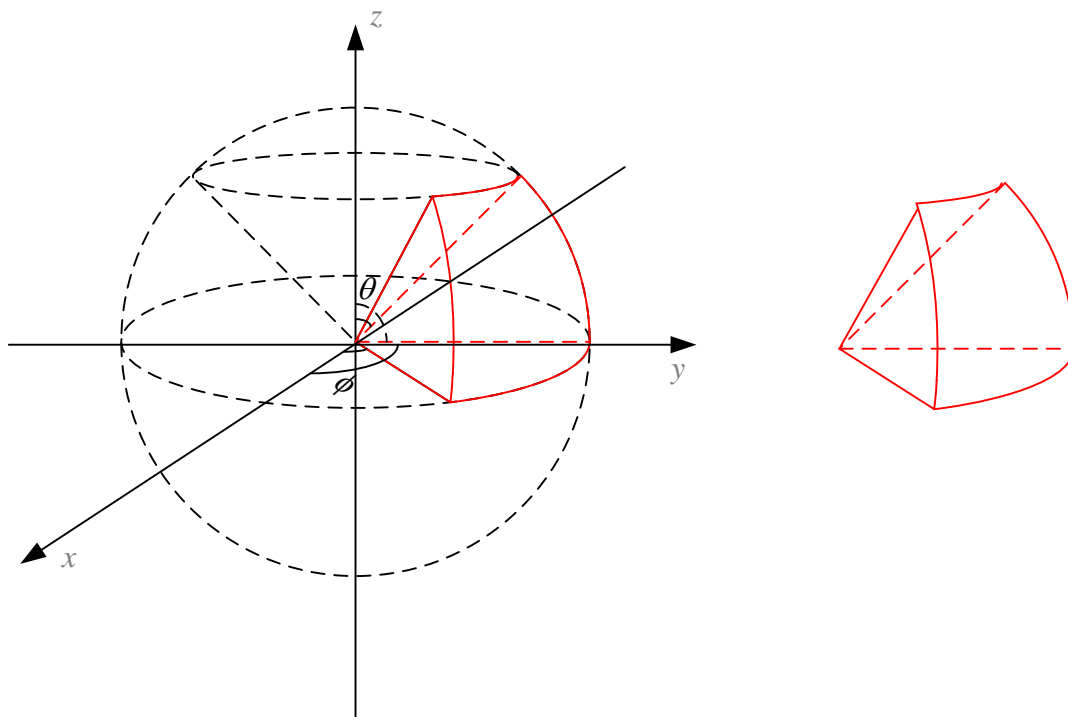


Figure 2.6 The surface of the exercise of Set 2.



## ECE2FH3 Electromagnetics I

Term II, January – April 2012

### MATLAB Examples and Exercises (Set 3)

Prepared by: Dr. M. H. Bakr and C. He

**Example:** An infinite uniform linear charge  $\rho_L = 2.0$  nC/m lies along the  $x$  axis in free space, while point charges of 8.0 nC each are located at  $(0, 0, 1)$  and  $(0, 0, -1)$ . Find  $\mathbf{E}$  at  $(2, 3, 4)$ . Write a MATLAB program to verify your answer.

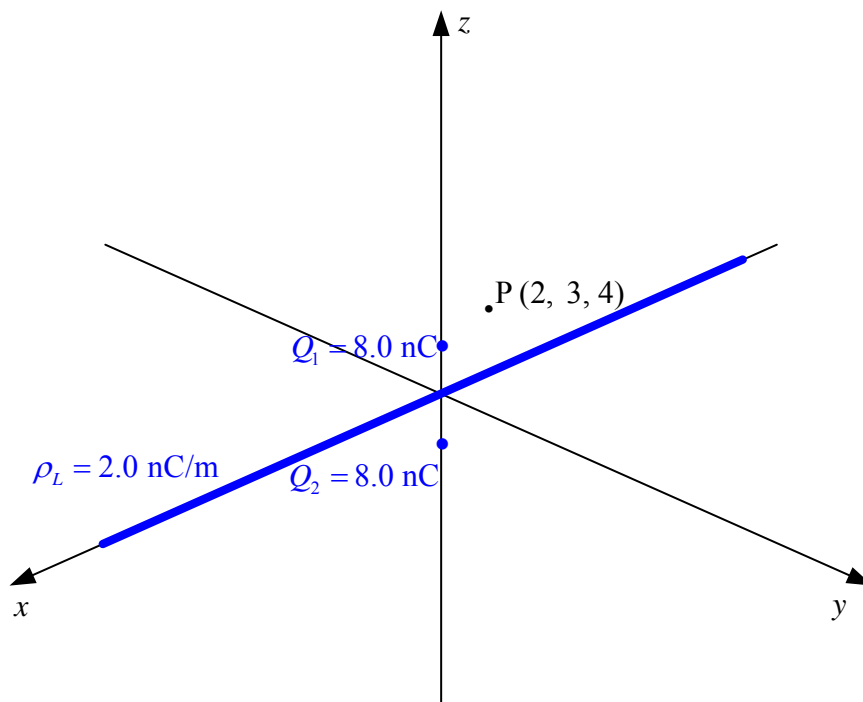


Figure 3.1 The charges of the example of Set 3.

**Analytical Solution:**

Based on the principle of superposition, the electric field at  $P(2, 3, 4)$  is  $\mathbf{E} = \mathbf{E}_1 + \mathbf{E}_2 + \mathbf{E}_L$  where  $\mathbf{E}_1$  and  $\mathbf{E}_2$  are the electric fields generated by the point charges 1 and 2, respectively, and  $\mathbf{E}_L$  is the electric field generated by the line charge. The electrical field generated by a point charge is given by

$$\mathbf{E}_{\text{point}} = \frac{Q}{4\pi\epsilon_0 |\mathbf{R}|^3} \mathbf{R}$$

where  $\mathbf{R}$  is the vector pointing from the point charge to the observation point as shown in Figure 3.2 (a).

For the point charge  $Q_1$ :

$$\mathbf{R}_1 = (2\mathbf{a}_x + 3\mathbf{a}_y + 4\mathbf{a}_z) - (\mathbf{a}_z) = 2\mathbf{a}_x + 3\mathbf{a}_y + 3\mathbf{a}_z$$

$$\begin{aligned} \mathbf{E}_1 &= \frac{Q_1}{4\pi\epsilon_0 |\mathbf{R}_1|^3} \mathbf{R}_1 \\ &= \frac{8 \times 10^{-9}}{4\pi \times \frac{1}{36\pi} \times 10^{-9} \times (\sqrt{2^2 + 3^2 + 3^2})^3} (2\mathbf{a}_x + 3\mathbf{a}_y + 3\mathbf{a}_z) \\ &= 1.395\mathbf{a}_x + 2.093\mathbf{a}_y + 2.093\mathbf{a}_z \end{aligned}$$

For the point charge  $Q_2$ :

$$\mathbf{R}_2 = (2\mathbf{a}_x + 3\mathbf{a}_y + 4\mathbf{a}_z) - (-\mathbf{a}_z) = 2\mathbf{a}_x + 3\mathbf{a}_y + 5\mathbf{a}_z$$

$$\begin{aligned} \mathbf{E}_2 &= \frac{Q_2}{4\pi\epsilon_0 |\mathbf{R}_2|^3} \mathbf{R}_2 \\ &= \frac{8 \times 10^{-9}}{4\pi \times \frac{1}{36\pi} \times 10^{-9} \times (\sqrt{2^2 + 3^2 + 5^2})^3} (2\mathbf{a}_x + 3\mathbf{a}_y + 5\mathbf{a}_z) \\ &= 0.615\mathbf{a}_x + 0.922\mathbf{a}_y + 1.537\mathbf{a}_z \end{aligned}$$

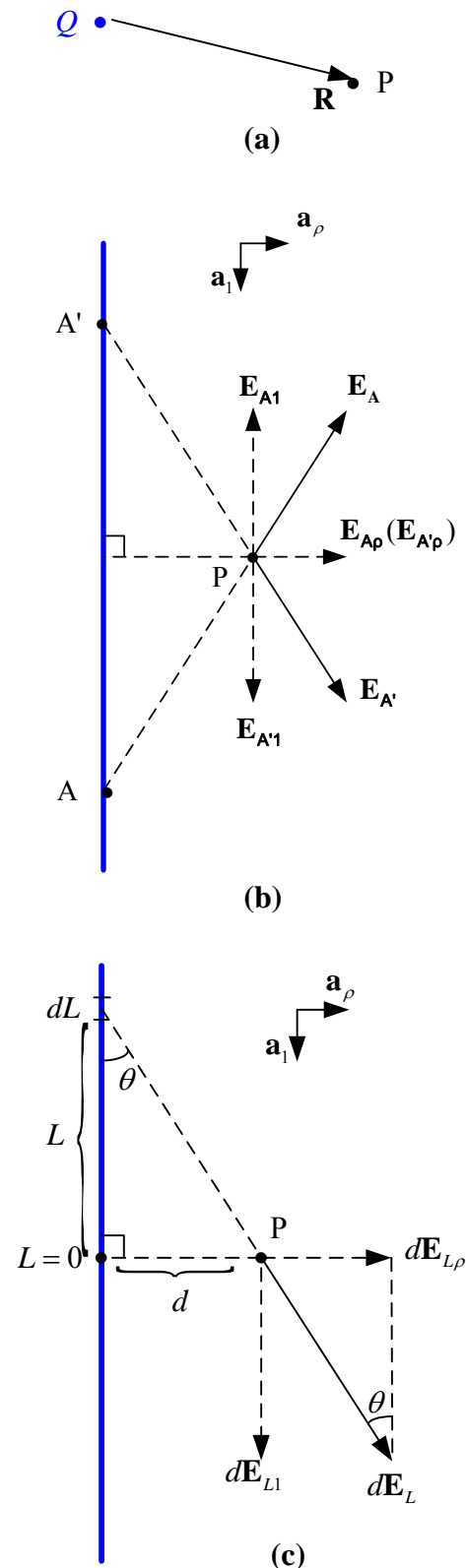


Figure 3.2. The different field components

As we can see from Figure 3.2(b), for any point A on the line charge we can always find one and only one point A' whose electric field at P has the same magnitude but the opposite sign of that of A in the direction which is parallel to the line charge. This is because the linear charge is infinitely long. Therefore we only need to find the electric field in the direction perpendicular to the line charge. As shown in Figure 3.2(c) each incremental length of line charge  $dL$  acts as a point charge and produces an incremental contribution to the total electric field intensity. The magnitude of  $d\mathbf{E}_L$  is thus:

$$dE_L = \frac{dQ}{4\pi\epsilon_0 |\mathbf{R}|^2} = \frac{\rho_L dL}{4\pi\epsilon_0 (L^2 + d^2)}$$

therefore the magnitude of  $d\mathbf{E}_\rho$  is

$$dE_{L\rho} = dE_L \sin \theta = \frac{\rho_L dL}{4\pi\epsilon_0 (L^2 + d^2)} \frac{d}{\sqrt{(L^2 + d^2)}} = \frac{\rho_L d}{4\pi\epsilon_0} \frac{dL}{(L^2 + d^2)^{3/2}}$$

and  $E_{L\rho} = \int_{L=-\infty}^{L=\infty} dE_\rho = \frac{\rho_L d}{4\pi\epsilon_0} \int_{L=-\infty}^{L=\infty} \frac{dL}{(L^2 + d^2)^{3/2}}$  (this integral is given in the formula sheet)

$$\begin{aligned} E_{L\rho} &= \frac{\rho_L d}{4\pi\epsilon_0} \times \frac{L}{d^2 \sqrt{L^2 + d^2}} \Bigg|_{L=-\infty}^{L=\infty} \\ &= \frac{\rho_L d}{4\pi\epsilon_0} \times \left( \frac{1}{d^2 \sqrt{1 + \frac{d^2}{L^2}}} \Bigg|_{L=\infty} - \frac{-1}{d^2 \sqrt{1 + \frac{d^2}{L^2}}} \Bigg|_{L=-\infty} \right) = \frac{\rho_L d}{4\pi\epsilon_0} \times \left( \frac{1}{d^2 \sqrt{1+0}} - \frac{-1}{d^2 \sqrt{1+0}} \right) = \frac{\rho_L}{2\pi\epsilon_0 d} \end{aligned}$$

Then we have to find  $\mathbf{a}_\rho$

$$\therefore \mathbf{R}_\rho = (2\mathbf{a}_x + 3\mathbf{a}_y + 4\mathbf{a}_z) - (2\mathbf{a}_x) = 3\mathbf{a}_y + 4\mathbf{a}_z$$

$$\therefore \mathbf{a}_\rho = \frac{\mathbf{R}_\rho}{|\mathbf{R}_\rho|} = \frac{3\mathbf{a}_y + 4\mathbf{a}_z}{\sqrt{3^2 + 4^2}} = \frac{3}{5}\mathbf{a}_y + \frac{4}{5}\mathbf{a}_z$$

therefore

$$\begin{aligned} \mathbf{E}_L &= \mathbf{E}_{L\rho} = E_{L\rho} \mathbf{a}_\rho \\ &= \frac{2 \times 10^{-9}}{2\pi \times \frac{1}{36\pi} \times 10^{-9} \times 5} \times \left( \frac{3}{5}\mathbf{a}_y + \frac{4}{5}\mathbf{a}_z \right) \\ &= 4.32\mathbf{a}_y + 5.76\mathbf{a}_z \end{aligned}$$

and

$$\mathbf{E} = \mathbf{E}_1 + \mathbf{E}_2 + \mathbf{E}_L = 2.01\mathbf{a}_x + 7.34\mathbf{a}_y + 9.39\mathbf{a}_z \text{ V/m}$$

**MATLAB solution :**

To find the electric field generated by the infinite line charge, we can replace the infinite linear charge by a sufficiently long finite line charge. In this problem, our line charge has a length of one hundred times of the distance from the observation point to the line charge, and its center is located at  $C(2, 0, 0)$  as shown in Figure 3.3. We divide the line charge into many equal segments, and evaluate the electric field generated by each segment in the way we evaluate the electric field generated by a single point charge. Finally, we evaluate the summation of the electric fields generated by all those segments. The summation should be very close to the electric field generated by the infinite linear charge. This approach can be summarized by the mathematical expression:

$$\mathbf{E}_L \doteq \sum_{i=1}^n \mathbf{E}_i = \sum_{i=1}^n \frac{\Delta Q}{4\pi\epsilon_0 |\mathbf{R}_i|^3} \mathbf{R}_i = \sum_{i=1}^n \frac{\rho_L \Delta L}{4\pi\epsilon_0 |\mathbf{R}_i|^3} \mathbf{R}_i$$

where  $\mathbf{E}_i$  is the electric field generated by the  $i$ th segment,  $\mathbf{R}_i$  is the vector from the  $i$ th segment to the observation point,  $\Delta Q$  is the charge of a single segment,  $\Delta L$  is the length of the segment and  $n$  is the total number of the segments.

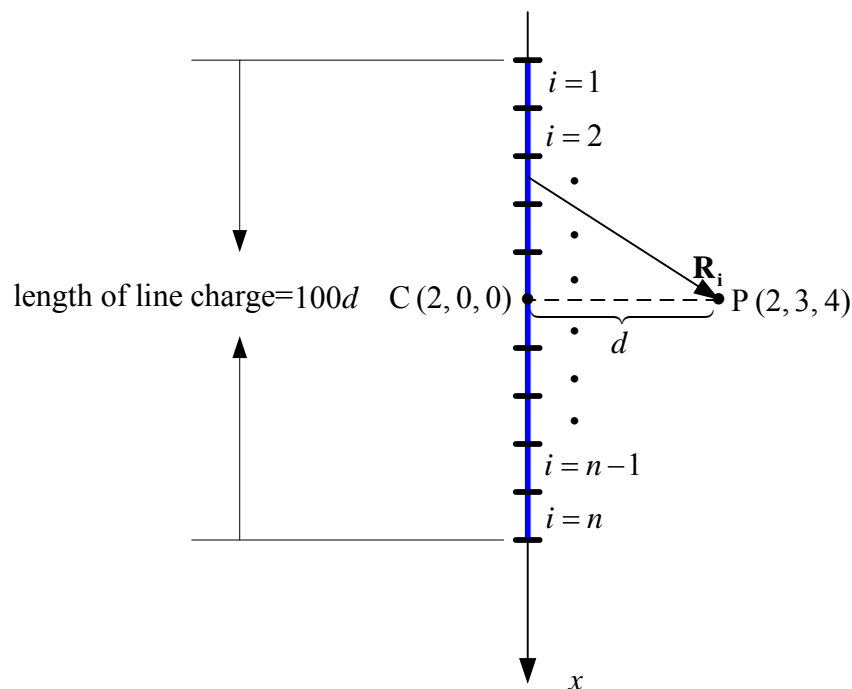


Figure 3.3 The discretization used in the MATLAB program.

**MATLAB code :**

```

clc; %clear the command line
clear; %remove all previous variables
Q1=8e-9;%charges on Q1
Q2=8e-9;%charges on Q2
pL=2e-9;%charge density of the line
Epsilono=8.8419e-12;%Permittivity of free space

P=[2 3 4];%coordinates of observation point
A=[0 0 1];%coordinates of Q1
B=[0 0 -1];%coordinates of Q2
C=[2 0 0];%coordinates of the center of the line charge
Number_of_L_Steps=100000;%the steps of L

%%the following routine calculates the electric fields at the
%%observation point generated by the point charges
R1=P-A; %the vector pointing from Q1 to the observation point
R2=P-B; %the vector pointing from Q2 to the observation point
R1Mag=norm(R1);%the magnitude of R1
R2Mag=norm(R2);%the magnitude of R1
E1=Q1/(4*pi*Epsilono*R1Mag^3)*R1;%the electric field generated by Q1
E2=Q2/(4*pi*Epsilono*R2Mag^3)*R2;%the electric field generated by Q2

%%the following routine calculates the electric field at the
%%observation point generated by the line charge
d=norm(P-C);%the distance from the observation point to the center of the line
length=100*d;%the length of the line
dL_V=length/Number_of_L_Steps*[1 0 0];%vector of a segment
dL=norm(dL_V);%length of a segment
EL=[0 0 0];%initialize the electric field generated by EL
C_segment=C-( Number_of_L_Steps/2*dL_V-dL_V/2);%the center of the first segment
for i=1: Number_of_L_Steps
    R=P-C_segment;%the vector seen from the center of the first segment to the
    observation point
    RMag=norm(R);%the magnitude of the vector R
    EL=EL+dL*pL/(4*pi*Epsilono*RMag^3)*R;%get contribution from each segment
    C_segment=C_segment+dL_V;%the center of the i-th segment
end

E=E1+E2+EL;% the electric field at P

```

**Running result**

```
Command Window
>> E
E =
    2.0102    7.3345    9.3890
>>
```

Comparing the MATLAB answer with the analytical answer we see that there is very little difference between them. This little difference is caused by the finite length of the steps of  $L$  and the finite line charge that we used to replace the infinite one.

## MATLAB Examples and Exercises (Set 3)

**Exercise:** A finite uniform linear charge  $\rho_L = 4 \text{ nC/m}$  lies on the xy plane as shown in Figure 3.4, while point charges of 8 nC each are located at  $(0, 1, 1)$  and  $(0, -1, 1)$ . Find  $\mathbf{E}$  at  $(0, 0, 0)$ . Write a MATLAB program to verify your answer.

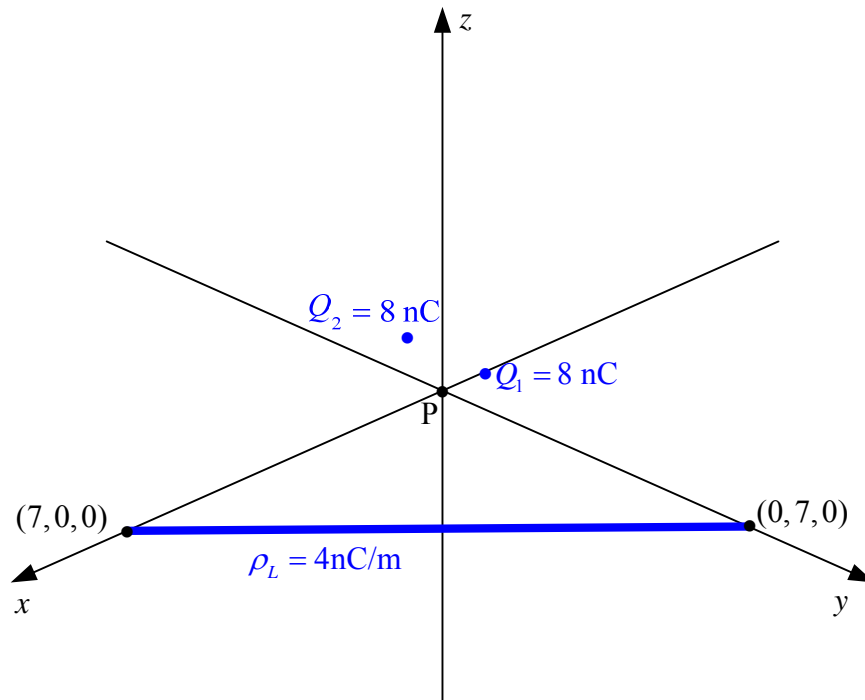


Figure 3.4 The charges of the exercise of Set 3.

## ECE2FH3 Electromagnetics I

Term II, January – April 2012

### MATLAB Examples and Exercises (Set 4)

Prepared by: Dr. M. H. Bakr and C. He

**Example:** A surface charge of  $5.0 \mu\text{C}/\text{m}^2$  is located in the  $x$ - $z$  plane in the region  $-2.0 \text{ m} \leq x \leq 2.0 \text{ m}$  and  $-3.0 \text{ m} \leq y \leq 3.0 \text{ m}$ . Find analytically the electric field at the point  $(0, 4.0, 0) \text{ m}$ . Verify your answer using a MATLAB program that applies the principle of superposition.

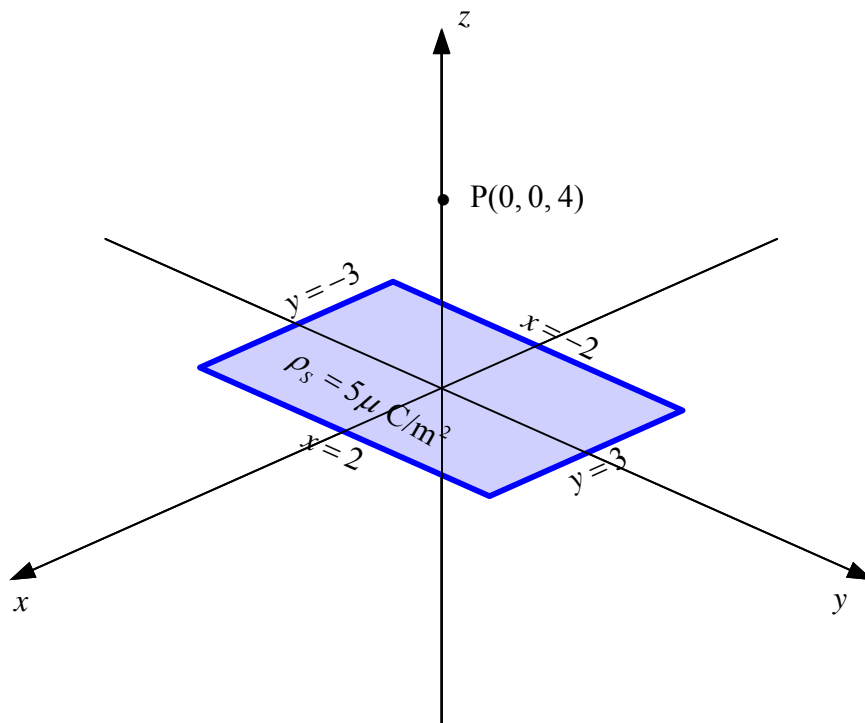


Figure 4.1 The surface charge of the example of Set 4.



**Analytical solution:**

As can be seen in Figure 4.2 , for any point A on the surface charge, we can find another point A' whose electric field at P has the same magnitude but the opposite sign of that of A in the direction parallel to the surface charge. Hence the electric field at P has only a z component .

$$dQ = \rho_s dS = \rho_s dx dy$$

$$dE = \frac{dQ}{4\pi\epsilon |\mathbf{R}|^2}$$

$$dE_z = dE \cos \theta$$

$$\cos \theta = \frac{|\mathbf{R}_z|}{|\mathbf{R}|} = \frac{4}{\sqrt{(x-0)^2 + (y-0)^2 + (4-0)^2}} = \frac{4}{\sqrt{x^2 + y^2 + 16}}$$

$$dE_z = \frac{\rho_s dx dy}{4\pi\epsilon |\mathbf{R}|^2} \frac{4}{\sqrt{x^2 + y^2 + 16}} = \frac{\rho_s}{\pi\epsilon (\sqrt{x^2 + y^2 + 16})^3} dx dy$$

$$E_z = \iint_s dE_z$$

$$= \int_{y=-3}^{y=3} \int_{x=-2}^{x=2} \frac{\rho_s}{\pi\epsilon (\sqrt{x^2 + y^2 + 16})^3} dx dy$$

$$= \frac{\rho_s}{\pi\epsilon} \int_{y=-3}^{y=3} \int_{x=-2}^{x=2} \frac{1}{(\sqrt{x^2 + y^2 + 16})^3} dx dy$$

$$= \frac{\rho_s}{\pi\epsilon} \int_{y=-3}^{y=3} \int_{x=-2}^{x=2} \frac{1}{(\sqrt{x^2 + a^2})^3} dx dy \quad (\text{let } a^2 = y^2 + 16)$$

$$= \frac{\rho_s}{\pi\epsilon} \int_{y=-3}^{y=3} \frac{x}{a^2 \sqrt{a^2 + x^2}} \Big|_{x=-2}^{x=2} dy$$

$$= \frac{\rho_s}{\pi\epsilon} \int_{y=-3}^{y=3} \frac{4}{(y^2 + 16)\sqrt{y^2 + 20}} dy$$

$$\text{let } y = \sqrt{20} \tan \alpha$$

$$\text{then } dy = \sqrt{20} \sec^2 \alpha d\alpha, \quad \sqrt{y^2 + 20} = \sqrt{20} \sec \alpha,$$

$$\text{and } y^2 + 16 = 20 \tan^2 \alpha + 16$$

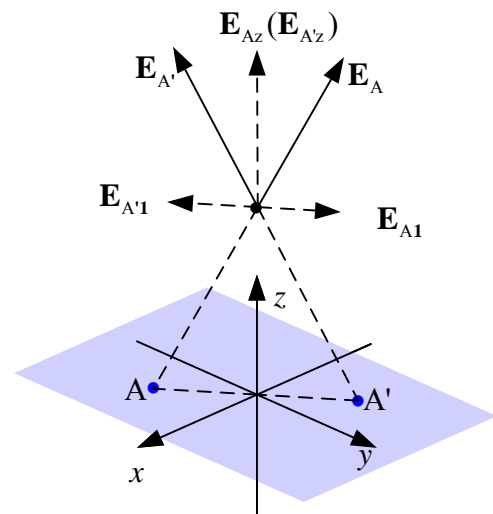


Figure 4.2 The field components.

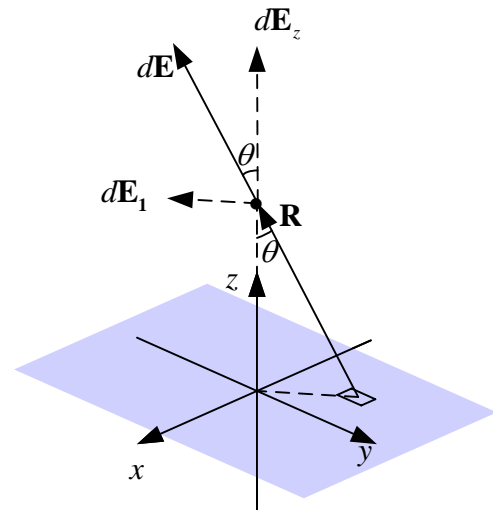


Figure 4.3 Field decomposition.

therefore

$$\begin{aligned}
 E_z &= \frac{4\rho_s}{\pi\epsilon} \int_{\alpha=\alpha_1}^{\alpha=\alpha_2} \frac{\sqrt{20} \sec^2 \alpha d\alpha}{(\sqrt{20} \sec \alpha)(20 \tan^2 \alpha + 16)} \\
 &= \frac{4\rho_s}{\pi\epsilon} \int_{\alpha=\alpha_1}^{\alpha=\alpha_2} \frac{\sec \alpha d\alpha}{20 \tan^2 \alpha + 16} \\
 &= \frac{4\rho_s}{\pi\epsilon} \int_{\alpha=\alpha_1}^{\alpha=\alpha_2} \frac{1}{20 \frac{\sin^2 \alpha}{\cos^2 \alpha} + 16} d\alpha \\
 &= \frac{4\rho_s}{\pi\epsilon} \int_{\alpha=\alpha_1}^{\alpha=\alpha_2} \frac{\cos \alpha d\alpha}{20 \sin^2 \alpha + 16 \cos^2 \alpha} \\
 &= \frac{4\rho_s}{\pi\epsilon} \int_{\alpha=\alpha_1}^{\alpha=\alpha_2} \frac{\cos \alpha d\alpha}{4 \sin^2 \alpha + 16} = \frac{\rho_s}{\pi\epsilon} \int_{y=-3}^{y=3} \frac{\cos \alpha d\alpha}{\sin^2 \alpha + 4}
 \end{aligned}$$

let  $u = \sin \alpha$  then  $du = \cos \alpha d\alpha$  therefore

$$\begin{aligned}
 E_y &= \frac{\rho_s}{\pi\epsilon} \int_{u=u_1}^{u=u_2} \frac{du}{u^2 + 4} \\
 &= \frac{\rho_s}{\pi\epsilon} \times \frac{1}{2} \arctan \frac{u}{2} \Big|_{y=-3}^{y=3} .
 \end{aligned}$$

as we can see from Figure 4.4,  $y = \sqrt{20} \tan \alpha$

and  $u = \sin \alpha$ . The relationship between  $u$  and  $z$  is given by

$$u = \frac{y}{\sqrt{y^2 + 20}}$$

therefore

$$\begin{aligned}
 E_y &= \frac{\rho_s}{\pi\epsilon} \times \frac{1}{2} \arctan \frac{u}{2} \Big|_{u=-3/\sqrt{29}}^{u=3/\sqrt{29}} \\
 &= \frac{5 \times 10^{-6}}{\pi \times \frac{1}{36\pi} \times 10^{-9}} \times \frac{1}{2} \times 2 \arctan \frac{\frac{3}{\sqrt{29}}}{2} = 4.8898 \times 10^4
 \end{aligned}$$

$$\mathbf{E} = E_y \mathbf{a}_y = 4.8898 \times 10^4 \mathbf{a}_y \text{ V/m}$$

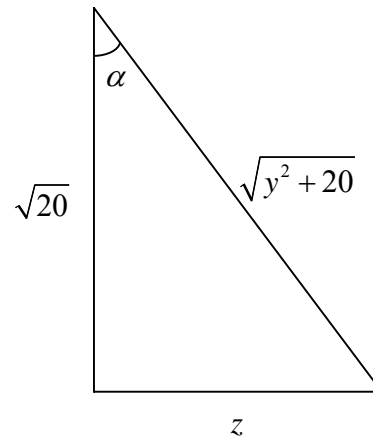


Figure 4.4  $u = \sin \alpha = \frac{y}{\sqrt{y^2 + 20}}$ .

**MATLAB Solution:**

To write a MATLAB code to solve this problem, we equally divide the surface into many cells each with a length  $\Delta y$  and a width  $\Delta x$ . Each cell has a charge of  $\Delta Q = \rho_s \Delta x \Delta y$ . When  $\Delta x$  and  $\Delta y$  are very small, the electric field generated by this cell is very close to that generated by a point charge with a charge  $\Delta Q$  located at the center of the cell. Hence the electric field generated by the surface charge at point P is given by

$$\mathbf{E} \doteq \sum_{j=1}^m \sum_{i=1}^n \Delta \mathbf{E}_{j,i} = \sum_{j=1}^m \sum_{i=1}^n \frac{\rho_s \Delta x \Delta y}{4\pi\epsilon |\mathbf{R}_{j,i}|^3} \mathbf{R}_{j,i}$$

where  $\mathbf{R}_{j,i}$  is the vector pointing from the center of a cell to the observation point, as shown in Figure 4.5.

The location of the center of a cell is given by  $x = -2 + \frac{\Delta x}{2} + \Delta x(i-1)$ ,  $y = -3 + \frac{\Delta y}{2} + \Delta y(j-1)$  and  $z = 0$ .

The MATLAB code is given in the next page.

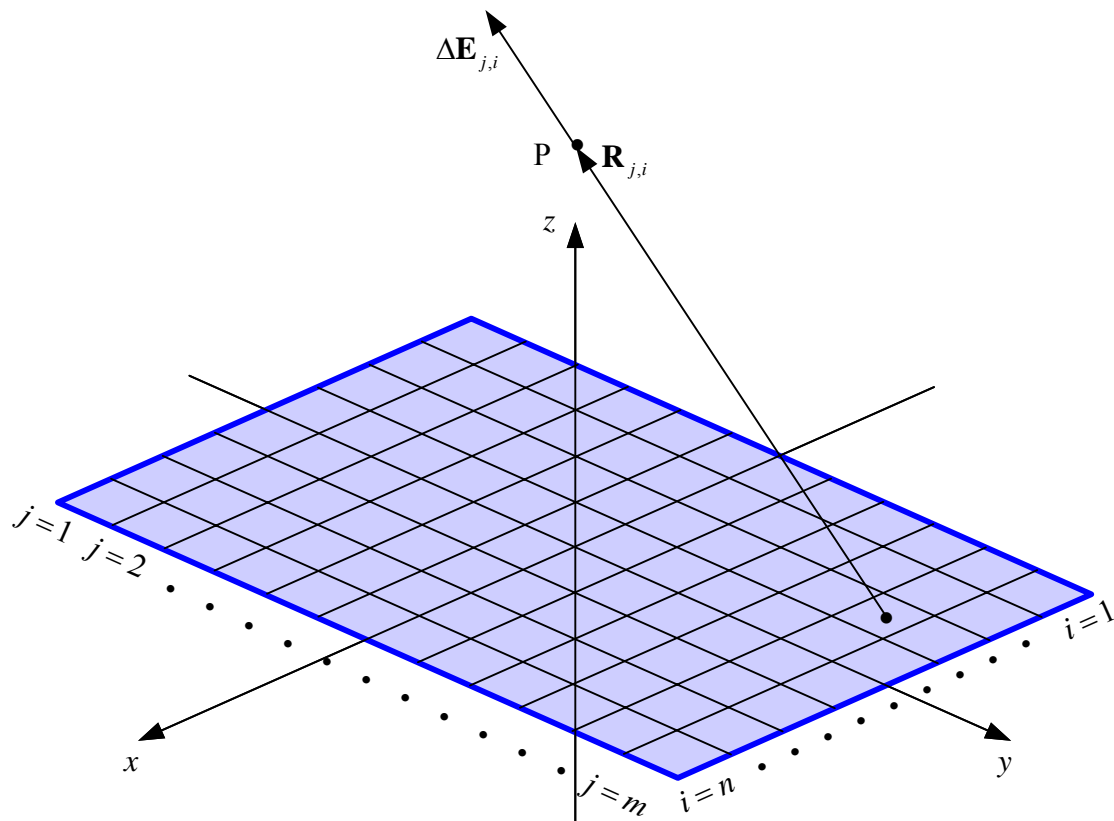


Figure 4.5 The utilized discretization in the MATLAB code.

**MATLAB code:**

```
clc; %clear the command line
clear; %remove all previous variables

Epsilono=8.854e-12; %use permittivity of air
D=5e-6; %the surface charge density
P=[0 0 4]; %the position of the observation point
E=zeros(1,3); % initialize E=(0 ,0, 0)

Number_of_x_Steps=100;%initialize discretization in the x direction
Number_of_y_Steps=100;%initialize discretization in %the z direction

x_lower=-2; %the lower boundary of x
x_upper=2; %the upper boundary of x
y_lower=-3; %the lower boundary of y
y_upper=-2; %the upper boundary of y
dx=(x_upper- x_lower)/Number_of_x_Steps; %the x increment or the width of a grid
dy=(y_upper- y_lower)/Number_of_y_Steps; %The y increment or the length of a grid
ds=dx*dy; %the area of a single grid
dQ=D*ds; % the charge on a single grid

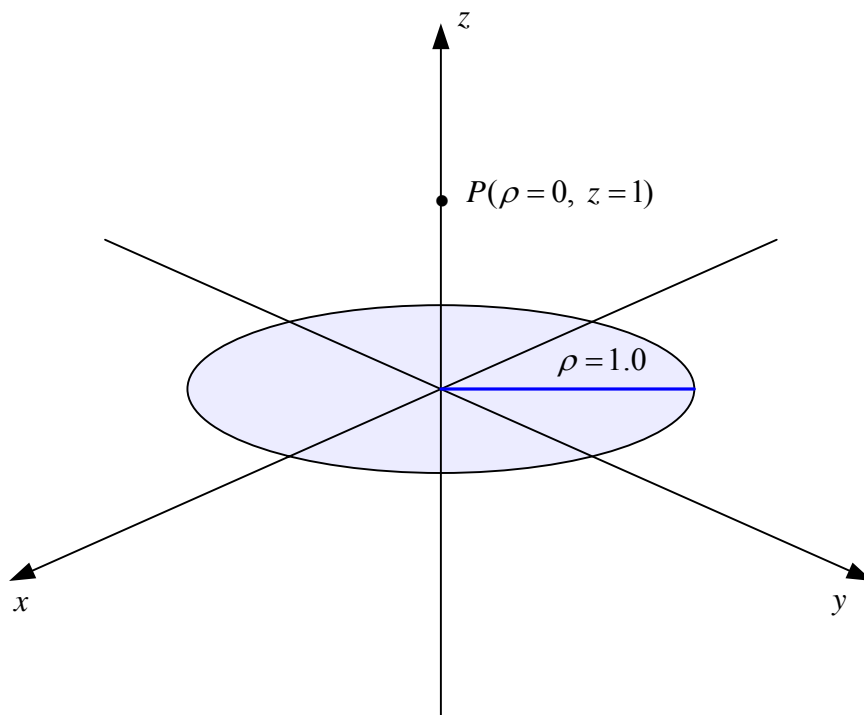
for j=1: Number_of_y_Steps
    for i=1: Number_of_x_Steps
        x= x_lower +dx/2+(i-1)*dx; %the x component of the center of a grid
        y= y_lower +dy/2+(j-1)*dy; %the y component of the center of a grid
        R=P-[x y 0];% vector R is the vector seen from the center of the grid to the
        observation point
        RMag=norm(R); % magnitude of vector R
        E=E+(dQ/(4*Epsilono*pi* RMag ^3))*R; % get contribution to the E field
    end
end
```

**Running result:**

```
Command Window
>> E
E =
1.0e+004 *
-0.0000    0.0000    4.8833
>>
```

Comparing the MATLAB answer and the analytical answer we see that there is a slight difference. This difference is a result of the finite discretization of the surface  $S$ .

**Exercise:** Given the surface charge density,  $\rho_s = 2.0 \mu\text{C}/\text{m}^2$ , existing in the region  $\rho < 1.0 \text{ m}$ ,  $z = 0$ , and zero elsewhere, find  $\mathbf{E}$  at  $P(\rho = 0, z = 1.0)$  and write a MATLAB program to verify your answer.



**Figure 4.6** The problem of the exercise of Set 4.

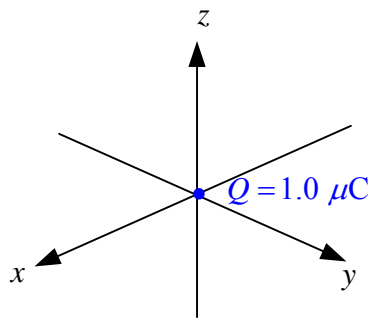
## ECE2FH3 Electromagnetics I

Term II, January – April 2012

### MATLAB Examples and Exercises (Set 5)

Prepared by: Dr. M. H. Bakr and C. He

**Example:** A point charge  $Q = 1.0 \mu\text{C}$  is located at the origin. Write a MATLAB program to plot the electric flux lines in the three-dimensional space.



**Figure 5.1** Point charge  $Q = 1.0 \mu\text{C}$  located at the origin.

#### Analytical Solution:

The electric flux density resulting from a point charge is given by  $\mathbf{D} = \frac{Q}{4\pi |\mathbf{R}|^3} \mathbf{R}$ , where  $\mathbf{R}$  is the vector pointing from the point charge to the observation point.

#### MATLAB Solution:

We first introduce two MATLAB functions that can help us to create a field vector plot.

```
1 meshgrid
```

Syntax:

```
[X,Y] = meshgrid(x,y)
```

```
[X,Y,Z] = meshgrid(x,y,z)
```

The rows of the output array X are copies of the vector x while columns of the output array Y are copies of the vector y.  $[X,Y] = \text{meshgrid}(x)$  is the same as  $[X,Y] = \text{meshgrid}(x,x)$ . For instance if we want to create a two-dimensional mesh grid as shown in Figures 5.2 and 5.3, we simply type  $[X Y] = \text{meshgrid}(-1:1:2, -1:1:3)$ , then X and Y is initialized as two-dimensional matrices

$$X = \begin{pmatrix} -1 & 0 & 1 & 2 \\ -1 & 0 & 1 & 2 \\ -1 & 0 & 1 & 2 \\ -1 & 0 & 1 & 2 \\ -1 & 0 & 1 & 2 \end{pmatrix}, Y = \begin{pmatrix} -1 & -1 & -1 & -1 \\ 0 & 0 & 0 & 0 \\ 1 & 1 & 1 & 1 \\ 2 & 2 & 2 & 2 \\ 3 & 3 & 3 & 3 \end{pmatrix}$$

If we compare the matrices X and Y with the mesh grids we see that matrix X stores the x components of all the points in the mesh grids and Y stores the y components of those points.  $[X,Y,Z] = \text{meshgrid}(x, y, z)$  is the 3-dimensional version of mesh grids.  $[X,Y,Z] = \text{meshgrid}(0:1:4, 0:1:4, 0:1:2)$  creates the mesh grids shown in Figure 5.4, and matrix X, Y and Z is given by

$$\begin{aligned} X(:, :, 1) &= \begin{pmatrix} 0 & 1 & 2 & 3 & 4 \\ 0 & 1 & 2 & 3 & 4 \\ 0 & 1 & 2 & 3 & 4 \\ 0 & 1 & 2 & 3 & 4 \\ 0 & 1 & 2 & 3 & 4 \end{pmatrix} & X(:, :, 2) &= \begin{pmatrix} 0 & 1 & 2 & 3 & 4 \\ 0 & 1 & 2 & 3 & 4 \\ 0 & 1 & 2 & 3 & 4 \\ 0 & 1 & 2 & 3 & 4 \\ 0 & 1 & 2 & 3 & 4 \end{pmatrix} & X(:, :, 3) &= \begin{pmatrix} 0 & 1 & 2 & 3 & 4 \\ 0 & 1 & 2 & 3 & 4 \\ 0 & 1 & 2 & 3 & 4 \\ 0 & 1 & 2 & 3 & 4 \\ 0 & 1 & 2 & 3 & 4 \end{pmatrix} \\ Y(:, :, 1) &= \begin{pmatrix} 0 & 0 & 0 & 0 & 0 \\ 1 & 1 & 1 & 1 & 1 \\ 2 & 2 & 2 & 2 & 2 \\ 3 & 3 & 3 & 3 & 3 \\ 4 & 4 & 4 & 4 & 4 \end{pmatrix} & Y(:, :, 2) &= \begin{pmatrix} 0 & 0 & 0 & 0 & 0 \\ 1 & 1 & 1 & 1 & 1 \\ 2 & 2 & 2 & 2 & 2 \\ 3 & 3 & 3 & 3 & 3 \\ 4 & 4 & 4 & 4 & 4 \end{pmatrix} & Y(:, :, 3) &= \begin{pmatrix} 0 & 0 & 0 & 0 & 0 \\ 1 & 1 & 1 & 1 & 1 \\ 2 & 2 & 2 & 2 & 2 \\ 3 & 3 & 3 & 3 & 3 \\ 4 & 4 & 4 & 4 & 4 \end{pmatrix} \\ Z(:, :, 1) &= \begin{pmatrix} 0 & 0 & 0 & 0 & 0 \\ 0 & 0 & 0 & 0 & 0 \\ 0 & 0 & 0 & 0 & 0 \\ 0 & 0 & 0 & 0 & 0 \\ 0 & 0 & 0 & 0 & 0 \end{pmatrix} & Z(:, :, 2) &= \begin{pmatrix} 1 & 1 & 1 & 1 & 1 \\ 1 & 1 & 1 & 1 & 1 \\ 1 & 1 & 1 & 1 & 1 \\ 1 & 1 & 1 & 1 & 1 \\ 1 & 1 & 1 & 1 & 1 \end{pmatrix} & Z(:, :, 3) &= \begin{pmatrix} 2 & 2 & 2 & 2 & 2 \\ 2 & 2 & 2 & 2 & 2 \\ 2 & 2 & 2 & 2 & 2 \\ 2 & 2 & 2 & 2 & 2 \\ 2 & 2 & 2 & 2 & 2 \end{pmatrix} \end{aligned}$$

Similar to the two-dimensional version, the matrices X, Y and Z store the x, y, and z components of all the plotting points, respectively.

## 2 quiver/quiver3

Syntax:

`quiver(X,Y,x_data,y_data)`

`quiver3(X,Y,Z,x_data,y_data,z_data)`



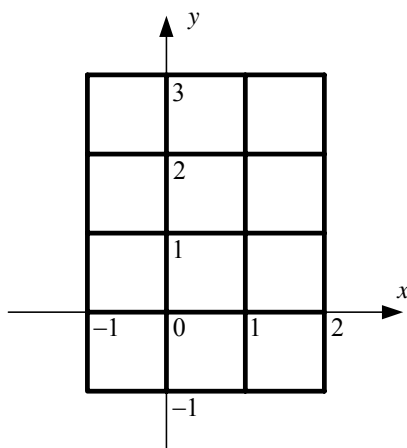
A quiver plot displays vectors as arrows with components ( $x\_data$ ,  $y\_data$ ) at the points ( $X$ ,  $Y$ ). For example, the first vector is defined by components  $x\_data(1), y\_data(1)$  and is displayed at the point  $X(1), Y(1)$ . The command `quiver(X,Y,x_data,y_data)` plots vectors as arrows at the coordinates specified in each corresponding pair of elements in  $x$  and  $y$ . The matrices  $X$ ,  $Y$ ,  $x\_data$ , and  $y\_data$  must all have the same size. The following MATLAB code plots the vector  $\mathbf{a}_x + 0.5\mathbf{a}_y$  at each plotting point in the mesh grids as shown in Figure 5.3.

```
PlotXmin=-1;
PlotXmax=2;
PlotYmin=-1;
PlotYmax=3;
NumberOfXPlottingPoints=4;
NumberOfYPlottingPoints=5;
PlotStepX=(PlotXmax-PlotXmin)/(NumberOfXPlottingPoints-1);
PlotStepY=(PlotYmax-PlotYmin)/(NumberOfYPlottingPoints-1);

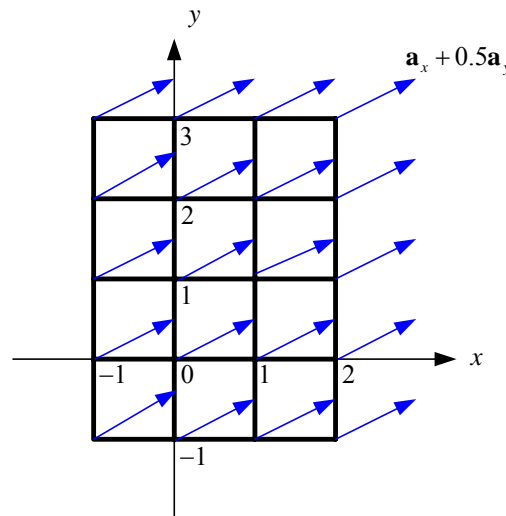
[X,Y]=meshgrid(PlotXmin:PlotStepX:PlotXmax,
PlotYmin:PlotStepY:PlotYmax);

for j=1:NumberOfYPlottingPoints
    for i=1:NumberOfXPlottingPoints
        x_data(j,i)=1;
        y_data(j,i)=0.5;
    end
end
quiver(X,Y,x_data,y_data)
```

`quiver3(X,Y,Z,x_data,y_data,z_data)` is used to plot vectors in three-dimensional space. The arguments  $X, Y, Z, x\_data, y\_data$  and  $z\_data$  are three-dimensional matrices.



**Figure 5.2** mesh grid created by  
`[X Y]= meshgrid(-1:1:2,-1:1:3).`



**Figure 5.3** field plot of the  
vector  $\mathbf{a}_x + 0.5\mathbf{a}_y$ .

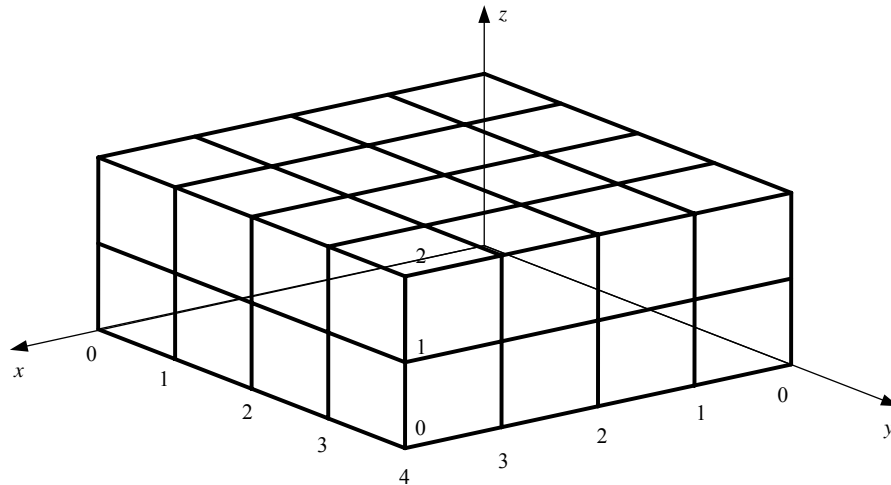


Figure 5.4 The mesh grid created by  $[x,Y,Z] = \text{meshgrid}(0:1:4,0:1:4,0:1:2)$ .

#### MATLAB code:

```

clc; %clear the command line
clear; %remove all previous variables

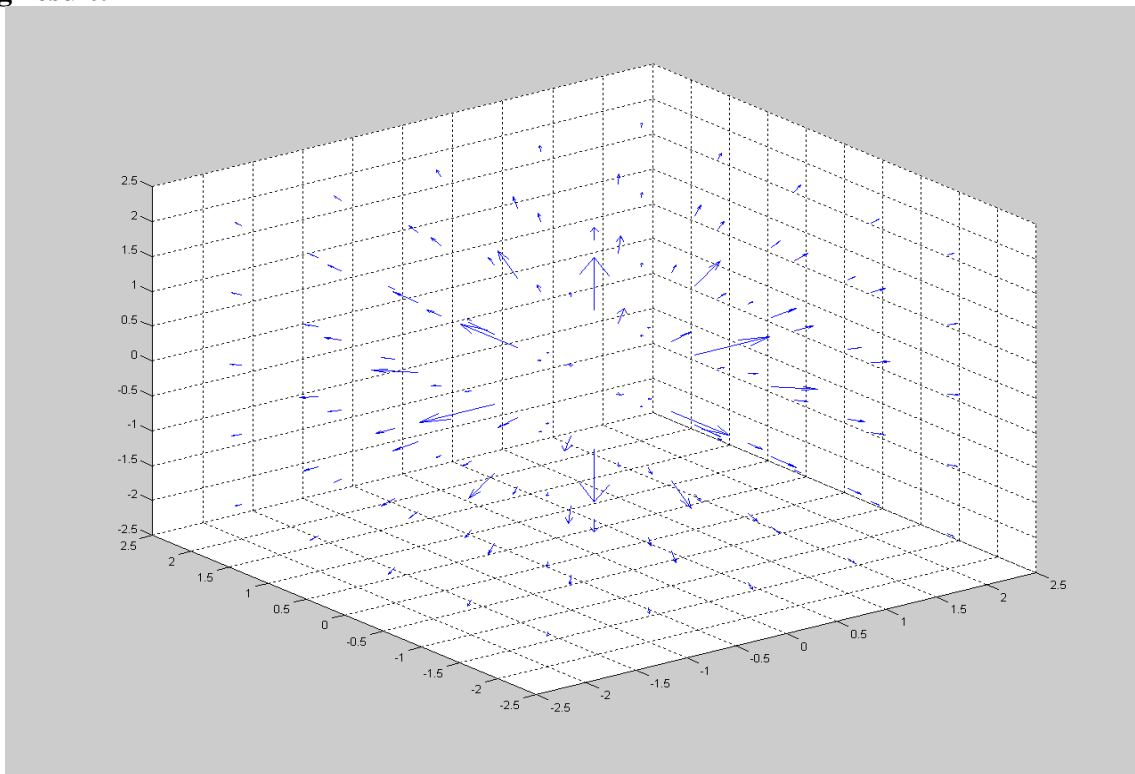
PlotXmin=-2;%lowest x value on the plot space
PlotXmax=2;%maximum x value on the plot space
PlotYmin=-2;%lowest y value on the plot space
PlotYmax=2;%maximum y value on the plot space
PlotZmin=-2;%lowest z value on the plot space
PlotZmax=2;%maximum z value on the plot space
NumberOfXPlottingPoints=5;%number of plotting points along the x axis
NumberOfYPlottingPoints=5;%number of plotting points along the y axis
NumberOfZPlottingPoints=5;%number of plotting points along the z axis
PlotStepX=(PlotXmax-PlotXmin)/(NumberOfXPlottingPoints-1);%plotting step in the x
direction
PlotStepY=(PlotYmax-PlotYmin)/(NumberOfYPlottingPoints-1);%plotting step in the y
direction
PlotStepZ=(PlotZmax-PlotZmin)/(NumberOfZPlottingPoints-1);%plotting step in the z
direction
[X,Y,Z]=meshgrid(PlotXmin:PlotStepX:PlotXmax,
PlotYmin:PlotStepY:PlotYmax,PlotZmin:PlotStepZ:PlotZmax);%build arrays of plot space

Fx=zeros(NumberOfZPlottingPoints,NumberOfYPlottingPoints,NumberOfXPlottingPoints);%x
component of flux density
Fy=zeros(NumberOfZPlottingPoints,NumberOfYPlottingPoints,NumberOfXPlottingPoints);%y
component of flux density
Fz=zeros(NumberOfZPlottingPoints,NumberOfYPlottingPoints,NumberOfXPlottingPoints);%z
component of the flux density
Q=1e-6;%point charge
C=[0 0 0];%location of the point charge
F=[0 0 0];%initialize the flux density

```

```
for k=1:NumberOfZPlottingPoints
    for j=1:NumberOfYPlottingPoints
        for i=1:NumberOfXPlottingPoints
            Xplot=X(k,j,i);%x coordinate of current plot point
            Yplot=Y(k,j,i);%y coordinate of current plot point
            Zplot=Z(k,j,i);%z coordinate of current plot point
            P=[Xplot Yplot Zplot];%position vector of observation points
            R=P-C; %vector pointing from point charge to the current observation
            point
            Rmag=norm(R);%magnitude of R
            if (Rmag>0)% no flux line defined at the source
                R_Hat=R/Rmag;%unit vector of R
                F=Q*R_Hat/(4*pi*Rmag^2);%flux density of current observation point
                Fx(k,j,i)=F(1,1);%get x component at the current observation point
                Fy(k,j,i)=F(1,2);%get y component at the current observation point
                Fz(k,j,i)=F(1,3);%get z component at the current observation point
            end
        end
    end
end
quiver3(X,Y,Z,Fx,Fy,Fz)
```

**Running result:**



**Figure 5.5** Plot of the electric flux resulting from a point charge located at the origin.

**Exercise:** Two line charges with linear densities of  $1.0 \mu\text{C}/\text{m}$  and  $-1.0 \mu\text{C}/\text{m}$  lie on the x-y plane parallel to the x-axis as shown in Figure 5.6. Write a MATLAB program to plot the electric flux lines in the region bounded by the dashed lines. Change the length of the linear charges to extend from  $-16$  to  $16$  in the x direction and plot the flux lines in the same region again.

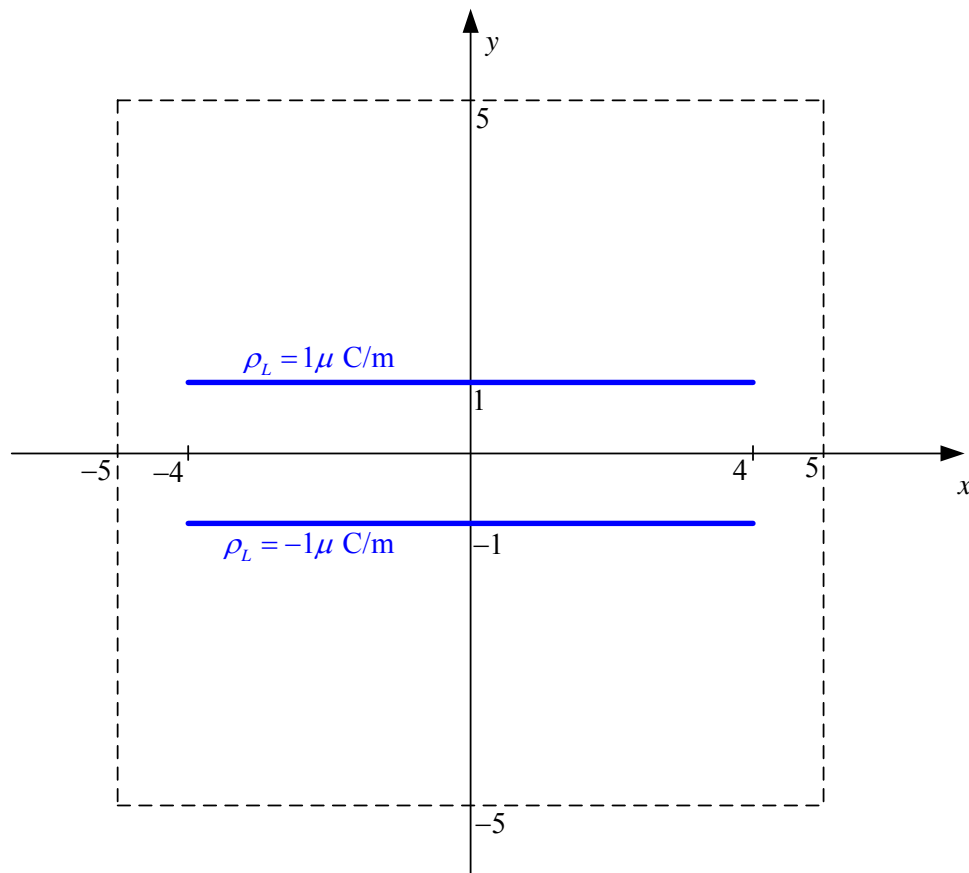


Figure 5.6 line charges with charge density of  $\rho_L = 1.0 \mu\text{C}/\text{m}$  located at  $y=1.0$  and  $y=-1.0$  on the x-y plane.

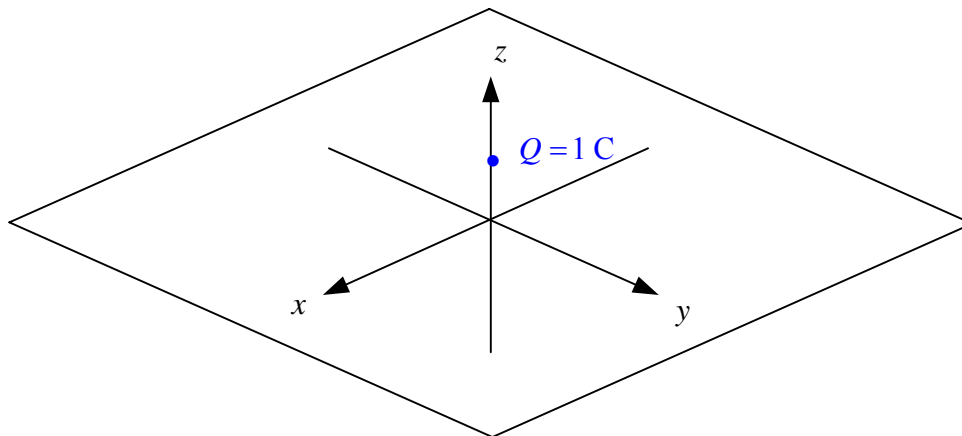
## ECE2FH3 Electromagnetics I

Term II, January – April 2012

### MATLAB Examples and Exercises (Set 6)

Prepared by: Dr. M. H. Bakr and C. He

**Example:** A point charge of 1.0 C is located at (0, 0, 1). Find analytically the total electric flux going through the infinite xy plane as shown in Figure 6.1. Verify your answer using a MATLAB program.



**Figure 6.1** The point charge of  $Q = 1.0$  C and the infinite x-y plane.

**Analytical solution:**

The total flux through a surface is given by

$$\Psi = \iint_S \mathbf{D}_S \cdot d\mathbf{s}$$

where  $d\mathbf{s}$  is a vector whose direction is normal to the surface element  $ds$  and has a magnitude of  $ds$ , and  $\mathbf{D}_S$  is the electric flux density passing through  $ds$ . In this problem (See Figure 6.2)

$$\mathbf{D}_S = \frac{Q}{4\pi R^2} \mathbf{a}_R$$

$$d\mathbf{s} = ds(-\mathbf{a}_z) = -dx dy \mathbf{a}_z$$

therefore the flux is given by

$$\Psi = \iint_S \mathbf{D}_S \cdot d\mathbf{s} = \iint_S \left( \frac{Q}{4\pi R^2} \mathbf{a}_R \right) \cdot (-dx dy \mathbf{a}_z).$$

This is the general method to evaluate the electric flux passing through a surface. However, for certain problems we can create a Gaussian surface to find out the flux passing through the surface and avoid evaluating any integral. The Gaussian surface we created for this problem is shown in Figure 6.3, where  $S_{top}$  and  $S_{bottom}$  are two parallel planes symmetric relative to the point charge  $Q$ . Based on Gauss's law, the total flux passing through the enclosed surface is

$$\Psi_{total} = \Psi_{top} + \Psi_{bottom} + \Psi_{side1} + \Psi_{side2} + \Psi_{side3} + \Psi_{side4} = \text{charge enclosed} = Q$$

since  $S_{top}$  and  $S_{bottom}$  are symmetric relative to the point charge  $Q$ ,

$$\Psi_{top} = \Psi_{bottom}.$$

Using the same reason

$$\Psi_{side1} = \Psi_{side2} = \Psi_{side3} = \Psi_{side4}$$

and since

$$\Psi_{side1} < \frac{Q}{4\pi L^2} \times (2Ld) = \frac{Qd}{2\pi L}$$

$$\frac{Qd}{2\pi L} \rightarrow 0 \text{ as } L \rightarrow \infty$$

we have

$$\Psi_{side1} \rightarrow 0 \text{ as } L \rightarrow \infty$$

Hence as  $L \rightarrow \infty$

$$\Psi_{total} = \Psi_{top} + \Psi_{bottom} = 2\Psi_{bottom} = Q$$

$$\Psi_{bottom} = \frac{Q}{2} = 0.5 \text{ C}$$

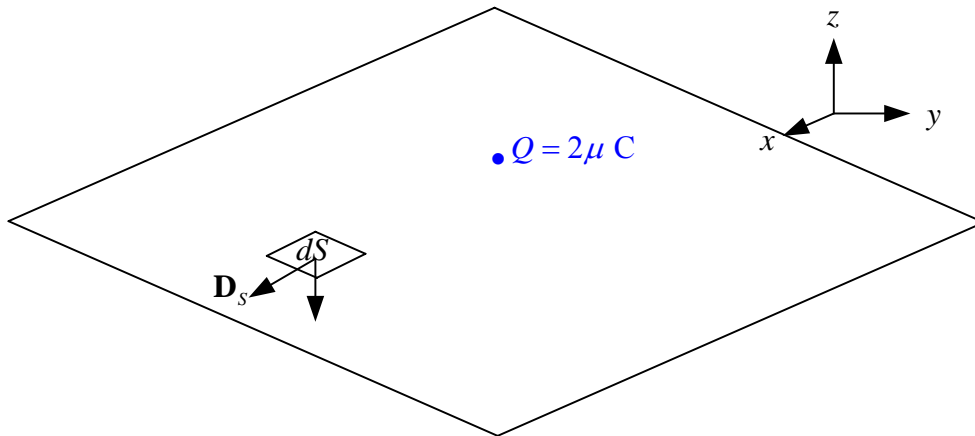


Figure 6.2 The electric flux through a surface element resulting from a point charge.

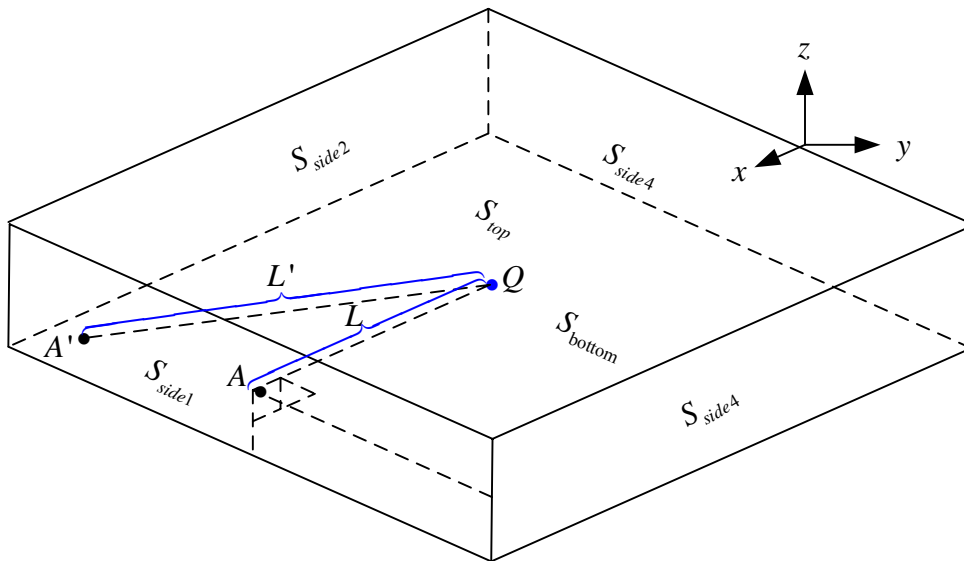


Figure 6.3 The electric field intensity at a point  $A$  is greater than any other point  $A'$  on the plane  $S_{side1}$  since  $L < L'$ . It follows that the flux through  $S_{side1}$ ,  $\Psi_{side1}$ , is smaller than  $(\text{Area of } S_{side1}) \times (\text{electric field density at point } A)$ .

**MATLAB Solution:**

To write a MATLAB program, we replace the infinite plane with a finite one with a very large area. We equally divide this plane into a number of surface elements each has an area of  $\Delta S$ . We then evaluate the flux  $\Delta\psi$  passing through each cell and add all the  $\Delta\psi$  together. This approach can be summarized by:

$$\Psi \doteq \sum_{j=1}^m \sum_{i=1}^n \Delta\psi_{i,j} = \sum_{j=1}^m \sum_{i=1}^n \mathbf{D}_{i,j} \cdot \Delta\mathbf{S}_{i,j} = \sum_{j=1}^m \sum_{i=1}^n \left( \frac{Q}{4\pi R_{i,j}^2} \mathbf{a}_{R_{i,j}} \right) \cdot (-\Delta S_{i,j} \mathbf{a}_z)$$

where  $\mathbf{R}_{i,j}$  is the vector pointing from the point charge to the center of the cell with indices  $i$  and  $j$ . Note that all  $\Delta S_{i,j}$  have the same direction  $-\mathbf{a}_z$ .

**MATLAB code**

```

clc; %clear the command line
clear; %remove all previous variables

Q=1;%the point charge
C=[0 0 1];%location of the point charge;
az=[0 0 1];% unit vector in the z direction

x_lower=-100;%the lower boundary of x of the plane
x_upper=100;% the upper boundary of x of the plane
y_lower=-100;%the lower boundary of y of the plane
y_upper=100;%the upper boundary of y of the plane
Number_of_x_Steps=400;%step in the x direction
Number_of_y_Steps=400;%step in the y direction
dx=(x_upper-x_lower)/Number_of_x_Steps;%the x increment
dy=(y_upper-y_lower)/Number_of_y_Steps;%the y increment

flux=0;%initialize the flux to 0

for j=1:Number_of_y_Steps
    for i=1:Number_of_x_Steps
        ds=dx*dy;%the area of current element
        x=x_lower+0.5*dx+(i-1)*dx;%x component of the center of a grid
        y=y_lower+0.5*dy+(j-1)*dy;%y component of the center of a grid
        P=[x y 0];%the center of a grid
        R=P-C;%vector R is the vector pointing from the point charge to the center of a
grid
        RMag=norm(R);%magnitude of R
        R_Hat=R/RMag;%unit vector in the direction of R
        R_surface=-az;%unit vector of direction of the surface element
        flux=flux+Q*ds*dot(R_surface,R_Hat)/(4*pi*RMag^2);%get contribution to the flux
    end
end

```

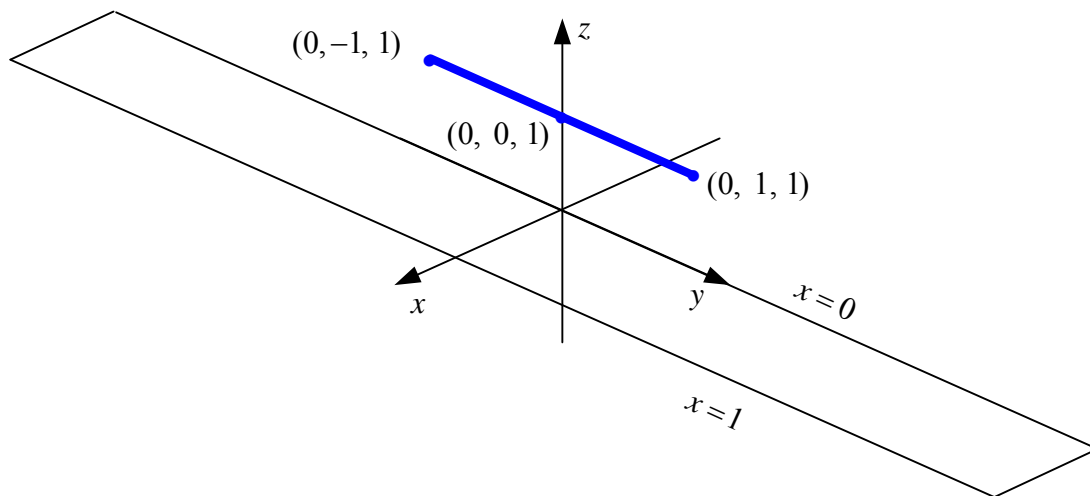


**Running result:**

```
>> flux  
  
flux =  
  
    0.4955  
  
>>
```

Comparing the MATLAB answer and the analytical answer we see that there is a good agreement between them. The small difference between the two answers is attributed to the finite discretizations of the surface  $S$ , and to utilizing a finite plane instead of the actual infinite plane.

**Exercise:** A linear charge  $\rho_L = 2.0 \mu\text{C}/\text{m}$  lies on the  $y$ - $z$  plane as shown in Figure 6.4. Find the electric flux passing through the plane extending from 0 to 1.0 m in the  $x$  direction and from  $-\infty$  to  $\infty$  in the  $y$  direction. Write a MATLAB program to verify your answer.



**Figure 6.4** a linear charge extending from  $(0, -1, 1)$  to  $(0, 1, 1)$  and a plane with infinite length and finite width.

## ECE2FH3 Electromagnetics I

Term II, January – April 2012

### MATLAB Examples and Exercises (Set 7)

Prepared by: Dr. M. H. Bakr and C. He

**Example:** A ring linear charge with a charge density  $\rho_L = 2.0 \text{ nC/m}$  is located on the x-y plane as shown in Figure 7.1. Find the potential difference between point A (0, 0, 1.0) and point B (0, 0, 2.0). Write a MATLAB program to verify your answer.

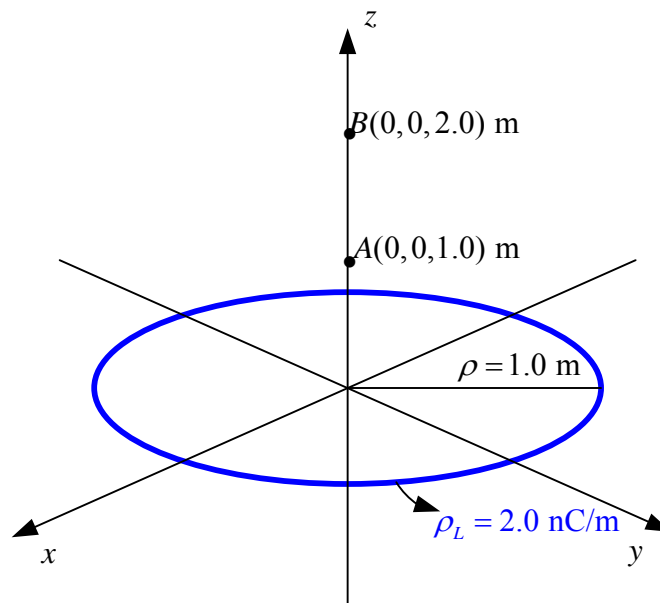


Figure 7.1 A ring linear charge with charge density of  $\rho_L = 2.0 \text{ nC/m}$  on the x-y plane.

**Analytical Solution:**

The potential difference between points A and B is given by

$$V_{AB} = -\int_B^A \mathbf{E} \cdot d\mathbf{L}$$

where  $d\mathbf{L} = \mathbf{a}_\rho d\rho + \mathbf{a}_\phi \rho d\phi + \mathbf{a}_z dz$  in cylindrical coordinate.

Since straight line BA is along the  $-z$  direction,  $\rho$  and  $\phi$  are both constant. This means  $d\rho = 0$  and  $d\phi = 0$ , hence  $d\mathbf{L} = \mathbf{a}_z dz$ .

$$\therefore V_{AB} = -\int_B^A \mathbf{E} \cdot d\mathbf{L} = -\int_{z=2.0}^{z=1.0} \mathbf{E} \cdot \mathbf{a}_z dz = -\int_{z=2.0}^{z=1.0} E_z dz.$$

For points on the positive  $z$ -axis we have

$$\begin{aligned} dE_z &= \frac{\rho_L dl}{4\pi\epsilon_0 |\mathbf{R}|^2} \cos\theta \\ &= \frac{\rho_L \rho d\phi}{4\pi\epsilon_0 (z^2 + \rho^2)} \frac{z}{\sqrt{z^2 + \rho^2}} \\ &= \frac{\rho_L \rho z d\phi}{4\pi\epsilon_0 (z^2 + \rho^2)^{3/2}} \end{aligned}$$

$$E_z = \oint_l dE_z = \int_{\phi=0}^{\phi=2\pi} \frac{\rho_L \rho z d\phi}{4\pi\epsilon_0 (z^2 + \rho^2)^{3/2}}$$

$$E_z = \frac{\rho_L \rho z}{4\pi\epsilon_0 (z^2 + \rho^2)^{3/2}} \phi \Big|_{\phi=0}^{\phi=2\pi} = \frac{\rho_L \rho z}{2\epsilon_0 (z^2 + \rho^2)^{3/2}}$$

$$V_{AB} = -\int_{z=2.0}^{z=1.0} E_z dz = -\int_{z=2.0}^{z=1.0} \frac{\rho_L \rho z}{2\epsilon_0 (z^2 + \rho^2)^{3/2}} dz$$

let  $u = z^2 + \rho^2$  (note that  $\rho = 1.0$  is a constant)

then  $du = 2z dz$

$$\begin{aligned} V_{AB} &= -\frac{\rho_L \rho}{4\epsilon_0} \int_{u=u_2}^{u=u_1} \frac{1}{u^{3/2}} du \\ &= \left( -\frac{\rho_L \rho}{4\epsilon_0} \right) \times \left( -2u^{-1/2} \right) \Big|_{u=u_2}^{u=u_1} \\ &= \frac{\rho_L \rho}{2\epsilon_0} \frac{1}{\sqrt{z^2 + \rho^2}} \Big|_{z=2.0}^{z=1.0} \\ &= \frac{2.0 \times 10^{-9} \times 1.0}{2 \times \frac{1}{36\pi} \times 10^{-9}} \times \left( \frac{1}{\sqrt{1.0^2 + 1.0^2}} - \frac{1}{\sqrt{2.0^2 + 1.0^2}} \right) \\ &= 29.4 \text{ V} \end{aligned}$$

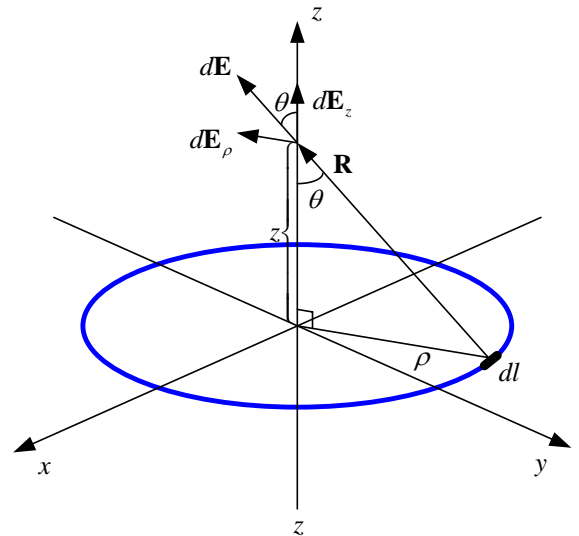
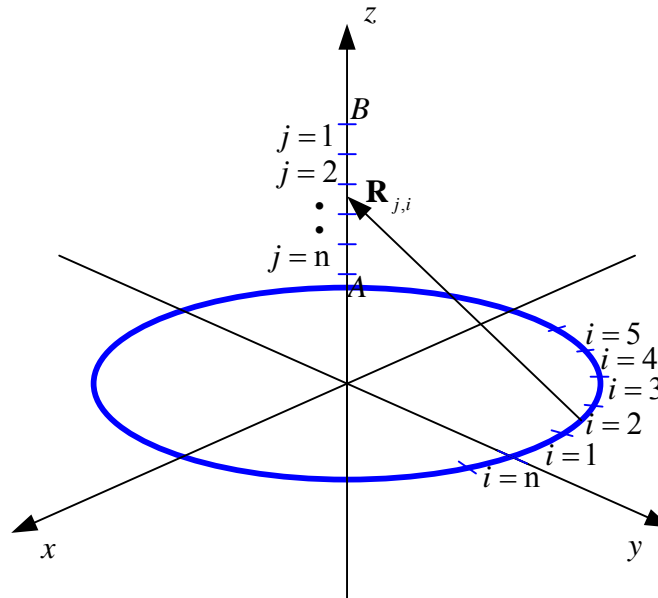


Figure 7.2 vector  $\mathbf{R}$  pointing from the element length  $dl$  to the observation point  $\theta$  is the angle between  $dE_z$  and  $d\mathbf{E}$ .

**MATLAB solution :**

To find the potential difference between  $A$  and  $B$  we can divide the integral path to many short segments and evaluate the potential difference along these segments. The summation of those potential differences will be very close to the voltage difference between  $A$  and  $B$ . However, we have to find out the electric field at each segment first. This can be done by dividing the ring charge to many segments, evaluating the electric field generated by each segment and adding all the electric field contributions together. This approach can be summarized using the mathematical expression:

$$\begin{aligned}
 V_{AB} &= \sum_{j=1}^m \Delta V_j \\
 &= \sum_{j=1}^m \mathbf{E}_j \cdot \Delta \mathbf{L}_j \\
 &= \sum_{j=1}^m \left( \sum_{i=1}^n \Delta \mathbf{E}_{j,i} \right) \cdot (\Delta \mathbf{L}_j) = \sum_{j=1}^m \left( \sum_{i=1}^n \frac{\rho_L \Delta l}{4\pi\epsilon_0 |\mathbf{R}_{j,i}|^2} \mathbf{R}_{j,i} \right) \cdot (\Delta \mathbf{L}_j)
 \end{aligned}$$



**Figure 7.3** The ring charge is divided along the  $a_\phi$  direction and the integral path is divided along the  $-a_z$  direction.

## MATLAB Examples and Exercises (Set 7)

**MATLAB code :**

```

clc; %clear the command line
clear; %remove all previous variables

Epsilono=1e-9/(36*pi); %use permitivity of free space
rho_L=2e-9;% the line charge density
rho=1.0; %the ring has a radius of 1.0;
A=[0 0 1];%the coordinate of point A
B=[0 0 2];%the coordinate of point B
Lv=A-B;%integral path
Number_of_L_Steps=50; %initialize discretization in the L direction
dLv=Lv/Number_of_L_Steps;%vector of the diffential length
Number_of_Phi_Steps=50; %initialize the Phi discretization
dPhi=(2*pi)/Number_of_Phi_Steps; %The step in the phi direction

V=0;%initialize the potential difference to zero
for j=1:Number_of_L_Steps
    E=[0 0 0];%initialize the elctric field to zero
    P=B+0.5*dLv+(j-1)*dLv;%coordinates of observation point
    for i=1:Number_of_Phi_Steps
        Phi=0.5*dPhi+(i-1)*dPhi; %Phi of current volume element
        dlength=rho*dPhi;%length of current segment of the ring
        dQ=rho_L*dlength;%the charges on current segment
        x=rho*cos(Phi); %x coordinate of current volume element
        y=rho*sin(Phi); %y coordinate of current volume element
        z=0; %z coordinate of current volume element
        C=[x y z]; %coordinate of volume element
        R=P-C; %vector pointing from the current element to the observation point
        RMag=norm(R); %get distance from the current volume element to the
observation point
        E=E+(dQ/(4*pi*Epsilono*RMag^3))*R; %get contribution to the elctric field
    end
    V=V+(-dot(dLv,E));%get contribution to the voltage
end
end

```

**Running result**

```
>> V
```

```
V =
```

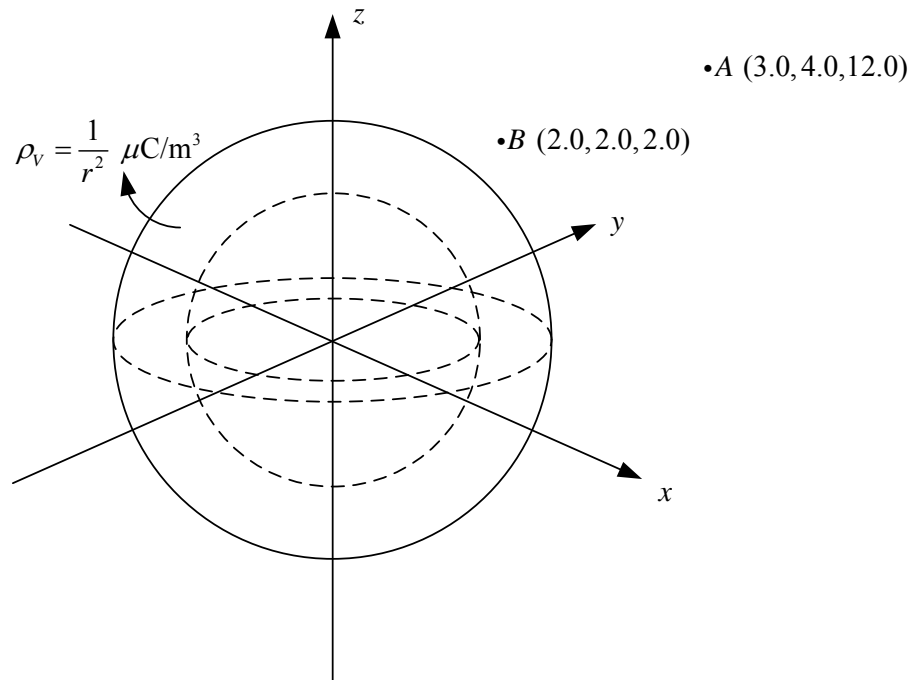
```
29.3931
```

```
>>
```

Comparing both answers, we see that our MATLAB solution and the analytical solution are consistent.

## MATLAB Examples and Exercises (Set 7)

**Exercise:** A volume charge density of  $\rho_v = 1/r^2 \mu\text{C}/\text{m}^3$  exists in the region bounded by  $1.0 \text{ m} < r < 1.5 \text{ m}$ . Find the potential difference between the point  $A (3.0, 4.0, 12.0)$  and the point  $B (2.0, 2.0, 2.0)$ , as shown in Figure 7.4. Write a MATLAB program to verify your answer.



**Figure 7.4** A volume charge density of  $\rho_v = \frac{1}{r^2} \mu\text{C}/\text{m}^3$  in the region bounded by  $1.0 \text{ m} < r < 1.5 \text{ m}$ .

## ECE2FH3 Electromagnetics I

Term II, January – April 2012

### MATLAB Examples and Exercises (Set 8)

Prepared by: Dr. M. H. Bakr and C. He

**Example:** An electric field  $\mathbf{E} = \frac{5 \times 10^4}{\rho} \mathbf{a}_\rho$  V/m exists in cylindrical coordinates. Find analytically the electric energy stored in the region bounded by  $1.0 \text{ m} < \rho < 2.0 \text{ m}$ ,  $-2.0 \text{ m} < z < 2.0 \text{ m}$  and  $0 < \phi < 2\pi$ , as shown in Figure 8.1. Verify your answer using a MATLAB program.

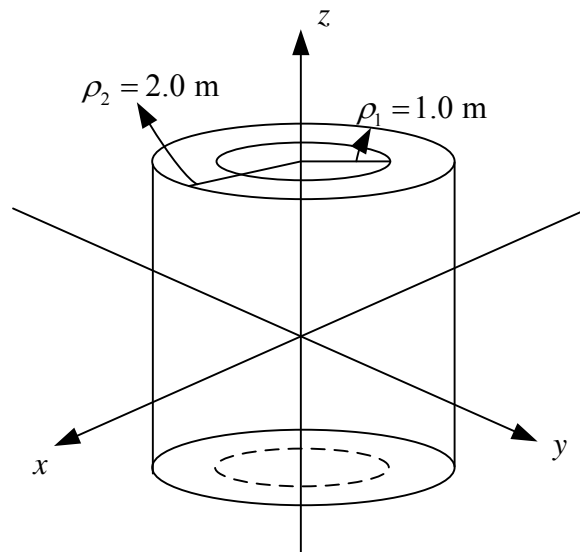


Figure 8.1 The region bounded by  $1.0 \text{ m} < \rho < 2.0 \text{ m}$ ,  $-2.0 \text{ m} < z < 2.0 \text{ m}$  and  $0 < \phi < 2\pi$ .



**Analytical solution:**

The energy stored in a region is given by

$$W_E = \frac{1}{2} \iiint_V \epsilon_0 E^2 dv$$

where  $E$  is the magnitude of the electric field at the volume element  $dv$  which is given by

$$E = |\mathbf{E}| = \frac{5 \times 10^4}{\rho} \text{ V/m}$$

In cylindrical coordinate we have  $dv = \rho d\rho d\phi dz$ , therefore

$$\begin{aligned} W_E &= \frac{1}{2} \iiint_V \epsilon_0 E^2 dv \\ &= \frac{1}{2} \int_{z=-2.0}^{z=2.0} \int_{\phi=0}^{\phi=2\pi} \int_{\rho=1.0}^{\rho=2.0} \epsilon_0 \left( \frac{5 \times 10^4}{\rho} \right)^2 \rho d\rho d\phi dz \\ &= \frac{2.5 \times 10^9 \epsilon_0}{2} \int_{z=-2.0}^{z=2.0} \int_{\phi=0}^{\phi=2\pi} \int_{\rho=1.0}^{\rho=2.0} \frac{1}{\rho} d\rho d\phi dz \\ &= \frac{2.5 \times 10^9 \epsilon_0}{2} \int_{z=-2.0}^{z=2.0} \int_{\phi=0}^{\phi=2\pi} \ln(\rho) \Big|_{\rho=1.0}^{\rho=2.0} d\phi dz \\ &= \frac{2.5 \times 10^9 \epsilon_0}{2} \times \ln(2) \int_{z=-2.0}^{z=2.0} \phi \Big|_0^{2\pi} dz \\ &= \frac{2.5 \times 10^9 \epsilon_0}{2} \times \ln(2) \times 2\pi z \Big|_{z=-2.0}^{z=2.0} \\ &= \frac{2.5 \times 10^9 \times \frac{1}{36\pi} \times 10^{-9}}{2} \times \ln(2) \times 2\pi \times 4 = 0.19254 \text{ J} \end{aligned}$$

**MATLAB Solution:**

To write a MATLAB program to evaluate the energy stored in the given region, we can divide the region into many small volume elements and evaluate the energy in each of these elements. Finally, the summation of these energies will be close to the total energy stored in the given region. The approach can be summarized using the mathematical expression:

$$\begin{aligned} W_E &= \sum_{k=1}^p \sum_{j=1}^m \sum_{i=1}^n \Delta W_{E_{k,j,i}} \\ &= \sum_{k=1}^p \sum_{j=1}^m \sum_{i=1}^n \frac{1}{2} \epsilon_0 |\mathbf{E}_{k,j,i}|^2 \Delta v_{k,j,i} \\ &= \sum_{k=1}^p \sum_{j=1}^m \sum_{i=1}^n \frac{1}{2} \epsilon_0 \left( \frac{5 \times 10^4}{\rho_{k,j,i}} \right)^2 \rho_{k,j,i} \Delta \rho \Delta \phi \Delta z \end{aligned}$$

**MATLAB code:**

```

clc; %clear the command line
clear; %remove all previous variables

Epsilono=1e-9/(36*pi); %use permitivity of free space
rho_upper=2.0;%upper bound of rho
rho_lower=1.0;%lower bound of rho
phi_upper=2*pi;%upper bound of phi
phi_lower=0;%lower bound of phi
z_upper=2;%upper bound of z
z_lower=-2;%lower bound of z
Number_of_rho_Steps=50; %initialize discretization in the rho direction
drho=(rho_upper-rho_lower)/Number_of_rho_Steps; %The rho increment
Number_of_z_Steps=50; %initialize the discretization in the z direction
dz=(z_upper-z_lower)/Number_of_z_Steps; %The z increment
Number_of_phi_Steps=50; %initialize the phi discretization
dphi=(phi_upper-phi_lower)/Number_of_phi_Steps; %The step in the phi direction

WE=0;%the total enery stored in the region
for k=1:Number_of_phi_Steps
    for j=1:Number_of_z_Steps
        for i=1:Number_of_rho_Steps
            rho=rho_lower+0.5*drho+(i-1)*drho; %radius of current volume element
            z=z_lower+0.5*dz+(j-1)*dz; %z of current volume element
            phi=phi_lower+0.5*dphi+(k-1)*dphi; %phi of current volume element
            EMag=5e4/rho;%magnitude of electric field of current volume element
            dV=rho*drho*dphi*dz;%volume of current element
            dWE=0.5*Epsilono*EMag*EMag*dV;%energy stored in current element
            WE=WE+dWE;%get contribution to the total energy
        end %end of the i loop
    end %end of the j loop
end %end of the k loop

```

**Running result:**

```
>> WE
```

```
WE =
```

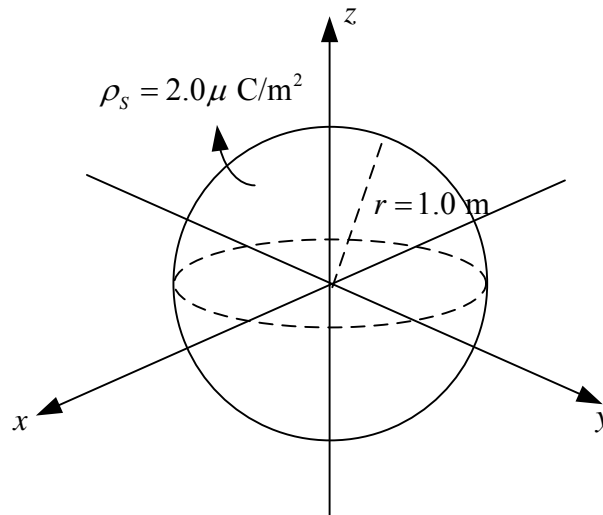
```
0.1925
```

```
>>
```

Comparing the two answers, we see that our MATLAB solution and analytical solution are consistent.

## MATLAB Examples and Exercises (Set 8)

**Exercise:** Given the surface charge density  $\rho_s = 2.0 \mu\text{C}/\text{m}^2$  existing in the region  $r = 1.0 \text{ m}$ ,  $0 < \phi < 2\pi$ ,  $0 < \theta < \pi$  and is zero elsewhere (See Figure 8.2) . Find analytically the energy stored in the region bounded by  $2.0 \text{ m} < r < 3.0 \text{ m}$ ,  $0 < \phi < 2\pi$  and  $0 < \theta < \pi$ . Write a MATLAB program to verify your answer.



**Figure 8.2** The surface charge density  $\rho_s = 2.0 \mu\text{C}/\text{m}^2$  at  $r = 1.0 \text{ m}$  .

## ECE2FH3 Electromagnetics I

Term II, January – April 2012

### MATLAB Examples and Exercises (Set 9)

Prepared by: Dr. M. H. Bakr and C. He

**Example:** Let  $\mathbf{J} = 400 \sin \theta / (r^2 + 4) \mathbf{a}_r$ , A/m<sup>2</sup>. Find the total current flowing through that portion of the spherical surface  $r = 0.8$ , bounded by  $0.1\pi < \theta < 0.3\pi$ , and  $0 < \phi < 2\pi$ . Verify your answer using a MATLAB program.

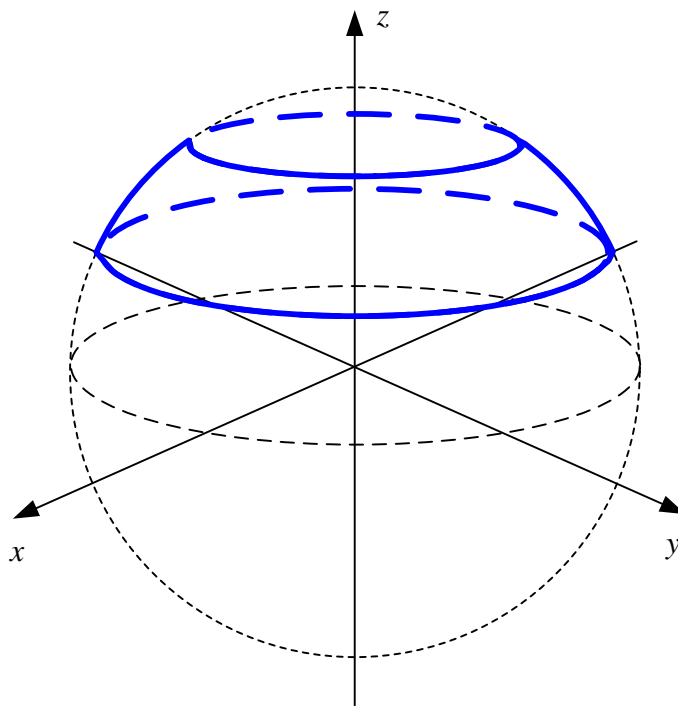


Figure 9.1 Surface bounded by  $r = 0.8$ ,  $0.1\pi < \theta < 0.3\pi$  and  $0 < \phi < 2\pi$ .

**Analytical solution:**

The current flowing through a surface is given by

$$I = \iint_S \mathbf{J} \cdot d\mathbf{S}$$

where  $d\mathbf{S} = r^2 \sin \theta d\theta d\phi \mathbf{a}_r$  in spherical coordinate. It follows that we have:

$$\begin{aligned} I &= \iint_S \left( \frac{400 \sin \theta}{r^2 + 4} \mathbf{a}_r \right) \cdot (r^2 \sin \theta d\theta d\phi \mathbf{a}_r) \\ &= \int_{\phi=0}^{\phi=2\pi} \int_{\theta=0.1\pi}^{\theta=0.3\pi} \frac{400r^2 \sin^2 \theta}{r^2 + 4} d\theta d\phi \\ &= \frac{400r^2}{r^2 + 4} \int_{\theta=0.1\pi}^{\theta=0.3\pi} \int_{\phi=0}^{\phi=2\pi} \sin^2 \theta d\phi d\theta \\ &= \frac{400r^2}{r^2 + 4} \int_{\theta=0.1\pi}^{\theta=0.3\pi} (\sin^2 \theta d\theta) \times \phi \Big|_{\phi=0}^{\phi=2\pi} \\ &= \frac{400r^2}{r^2 + 4} \times 2\pi \int_{\theta=0.1\pi}^{\theta=0.3\pi} \sin^2 \theta d\theta \\ &= \frac{400r^2}{r^2 + 4} \times 2\pi \int_{\theta=0.1\pi}^{\theta=0.3\pi} \left[ \frac{1}{2} - \frac{\cos(2\theta)}{2} \right] d\theta \end{aligned}$$

let  $u = 2\theta$  then  $du = 2d\theta$  and we have

$$\begin{aligned} I &= \frac{400r^2}{r^2 + 4} \times 2\pi \int_{u=0.2\pi}^{u=0.6\pi} \frac{1}{2} \times \left[ \frac{1}{2} - \frac{\cos u}{2} \right] du \\ &= \frac{400r^2}{r^2 + 4} \pi \times \left( \frac{1}{2} u - \frac{\sin u}{2} \right) \Big|_{u=0.2\pi}^{u=0.6\pi} \\ &= \frac{400 \times 0.8^2}{0.8^2 + 4} \pi \times \left[ \left( \frac{1}{2} \times 0.6\pi - \frac{\sin 0.6\pi}{2} \right) - \left( \frac{1}{2} \times 0.2\pi - \frac{\sin 0.2\pi}{2} \right) \right] \\ &= 77.42 \text{ A} \end{aligned}$$

**MATLAB Solution:**

To write a MATLAB program to evaluate the current flowing through the given surface, we divide that surface into many small surfaces and evaluate the currents flowing through each surface element. The summation of these elemental currents will be close to the actual current flowing through the given surface. This approach can be summarized by the following expression:

$$\begin{aligned} I &= \sum_{j=1}^m \sum_{i=1}^n \mathbf{J}_{i,j} \cdot \Delta\mathbf{S}_{i,j} \\ &= \sum_{j=1}^m \sum_{i=1}^n \left( \frac{400 \sin \theta_{i,j}}{r^2 + 4} \mathbf{a}_r \right) \cdot (r^2 \sin \theta_{i,j} d\theta_{i,j} d\phi_{i,j} \mathbf{a}_r) \end{aligned}$$

**MATLAB code:**

```

clc; %clear the command line
clear; %remove all previous variables
R=0.8;%the radius of the surface
Theta_lower=0.1*pi;%lower boundary of theta
Theta_upper=0.3*pi;%upper boundary of theta
Phi_lower=0;%lower boundary of phi
Phi_upper=2*pi;%upper boundary of phi
Number_of_Theta_Steps=20; %initialize the discretization in the Theta direction
dTheta=(Theta_upper-Theta_lower)/Number_of_Theta_Steps; %The Theta increment
Number_of_Phi_Steps=20;%initialize the discretization in the Phi direction
dPhi=(Phi_upper-Phi_lower)/Number_of_Phi_Steps;%The Phi increment
I=0; %initialize the total current
for j=1:Number_of_Phi_Steps
    for i=1:Number_of_Theta_Steps
        Theta=Theta_lower+0.5*dTheta+(i-1)*dTheta; %Theta of current surface element
        Phi=Phi_lower+0.5*dPhi+(j-1)*dPhi; %Phi of current surface element
        x=R*sin(Theta)*cos(Phi); %x coordinate of current surface element
        y=R*sin(Theta)*sin(Phi); %y coordinate of current surface element
        z=R*cos(Theta); %z coordinate of current surface element
        a_r=[sin(Theta)*cos(Phi) sin(Theta)*sin(Phi) cos(Theta)];% the unit vector in the R direction
        J=(400*sin(Theta)/(R*R+4))*a_r;%the current density of current surface element
        dS=R*R*sin(Theta)*dTheta*dPhi*a_r;%the area of current surface element
        I=I+dot(J,dS);%get contribution to the total current
    end
end

```

**Running result:****Command Window**

```
>> I
```

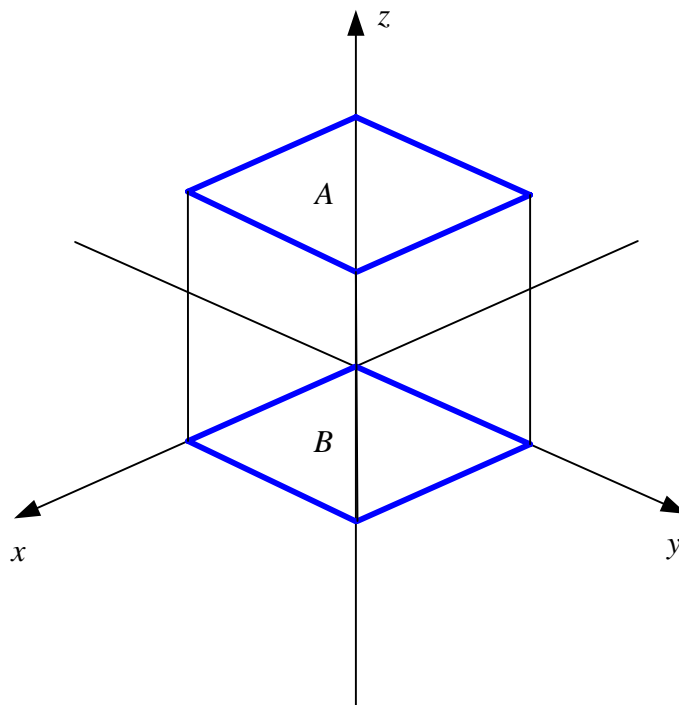
```
I =
```

```
77.4180
```

```
>>
```

Comparing the answers we see that our MATLAB solution and analytical solution are consistent.

**Exercise:** A rectangular conducting plate lies in the  $xy$  plane, occupying the region  $0 < x < 5.0$  m,  $0 < y < 5.0$  m. An identical conducting plate is positioned parallel to the first one at  $z = 10.0$  m. The region between the plates is filled with a material having a conductivity  $\sigma(x) = e^{-x/10}$  S/m. It is known that an electric field intensity  $\mathbf{E} = -50\mathbf{a}_z$  V/m exists within the material. Find: (a) the potential difference  $V_{AB}$  between the two plates; (b) the total current flowing between the plates; (c) the resistance of the material.



**Figure 9.2** The volume between the conducting plates is filled with a material having conductivity  $\sigma(x) = e^{-x/10}$  S/m.

## ECE2FH3 Electromagnetics I

Term II, January – April 2012

### MATLAB Examples and Exercises (Set 10)

Prepared by: Dr. M. H. Bakr and C. He

**Example:** An infinite line charge with charge density  $\rho_L = \rho_0$  lies on the  $z$  axis. Two infinite conducting planes are located at  $y = a$  and  $y = a - h$  and both have zero potential. Find the voltage at any given point  $(x, y)$ . If  $\rho_0 = 1.0 \times 10^{-7}$  C/m,  $a = 1.0$  m and  $h = 2.0$  m, plot the contours of the voltage.

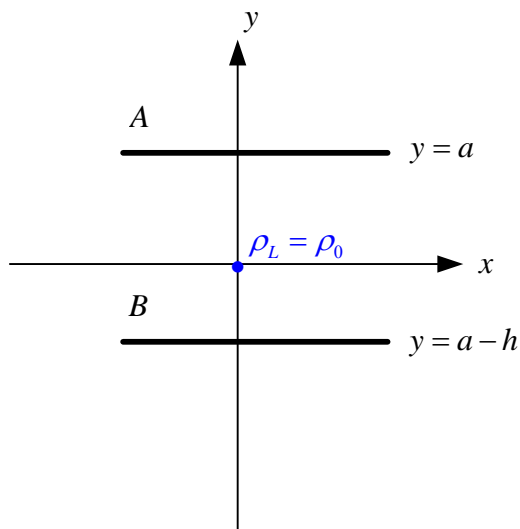


Figure 10.1 The infinite line charge and the two ground planes.



**Analytical solution:**

The potential difference in an electric field resulting from a line charge is given by:

for  $\rho_M \geq \rho_N$ ,  $\therefore d\mathbf{L} = \mathbf{a}_\rho d\rho$

$$\therefore V_{MN} = -\int_N^M \mathbf{E} \cdot d\mathbf{L} = -\int_{\rho_N}^{\rho_M} \frac{\rho_L}{2\pi\epsilon\rho} d\rho = -\frac{\rho_L}{2\pi\epsilon} \ln \rho \Big|_{\rho=\rho_N}^{\rho=\rho_M} = \frac{\rho_L}{2\pi\epsilon} \ln \frac{\rho_N}{\rho_M}$$

$$\text{therefore } V_{MN} = \frac{\rho_L}{2\pi\epsilon} \ln \frac{\rho_N}{\rho_M}.$$

If we define the voltage at  $\rho = \rho_N = 1$  to be zero, then the

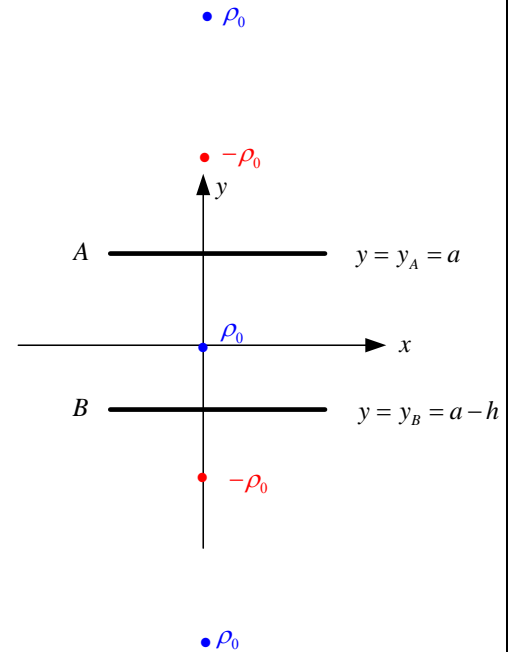
potential at  $\rho = \rho_M$  is  $V_M = -\frac{\rho_L}{2\pi\epsilon} \ln \rho_M$ .

Since the conducting planes have zero potential, image charges are required in order to cancel out the voltage created by the original charge. In this problem, as shown in Figure 10.2 we need infinite number of images to maintain the zero voltage of the conducting planes. The next steps is to find the coordinates and polarities of all image charges. Let's first consider a point  $P(x_p, y_p)$  and a straight line  $y = y_L$  as shown in Figure 10.3.

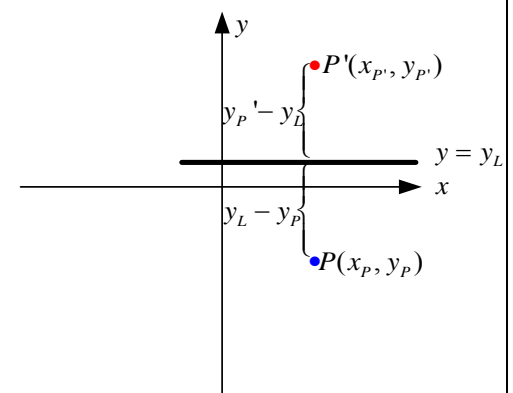
The image of  $P$  relative to the straight line can be obtained by

$$\begin{cases} x_{p'} = x_p \\ y_{p'} - y_L = y_L - y_p \end{cases} \Rightarrow \begin{cases} x_{p'} = x_p \\ y_{p'} = 2y_L - y_p \end{cases} \Rightarrow P'(x_p, 2y_L - y_p)$$

This expression will be used later. To find the coordinates and polarities of the images, we can divide all the images into two groups. If we only count the first image of plane B and all the sub-images created by that first image, then the images that we counted are put into group 1 (shown in Figure 10.4). If we only count the first image of plane A and all the sub-images created by that first image, then the images that we counted are put into group 2 (shown in Figure 10.5). In group 1, the  $y$  coordinate of the first image is  $y_1 = 2y_A - y_0$  where  $y_A$  is the  $y$  coordinate of plane A and  $y_0$  is the  $y$  coordinate of the original charge. Then for the second image  $y_2 = 2y_B - y_1$ , for the third image  $y_3 = 2y_A - y_2$  and so on. In group 2, the  $y$  coordinate of the first image is  $y_1 = 2y_B - y_0$ , for the second image  $y_2 = 2y_A - y_1$ , for the third image  $y_3 = 2y_B - y_2$  and so on. The following table summarizes the polarities and  $y$  coordinates of all images.



**Figure 10.2** infinite number of images are required to maintain zero potential on the conducting plates



**Figure 10.3** image of a point  $P$  relative to the straight line  $y = y_L$

group 1		
level	y coordinate	polarity
1	$2a - 2h$	-
2	$2h$	+
3	$2a - 4h$	-
4	$4h$	+
3	$2a - 6h$	-
6	$6h$	+
group 2		
level	y coordinate	polarity
1	$2a$	-
2	$-2h$	+
3	$2a + 2h$	-
4	$-4h$	+
3	$2a + 4h$	-
6	$-6h$	+

From the table above we can find that  $y_{image} = 2nh$  ( $n \in \mathbb{Z}, n \neq 0$ ) or  $y_{image} = 2a + 2nh$  ( $n \in \mathbb{Z}$ ). Since the original charge has a y coordinate of  $y_0 = 0$  which can be rewritten as  $y_0 = 2nh$  ( $n = 0$ ), the voltage at point  $(x, y)$  is given by

$$V = \sum_{n=-\infty}^{n=\infty} \frac{-\rho}{2\pi\epsilon} \ln \sqrt{x^2 + (y - 2nh)^2} + \sum_{n=-\infty}^{n=\infty} \frac{\rho}{2\pi\epsilon} \ln \sqrt{x^2 + (y - 2a - 2nh)^2}$$

$$= \frac{\rho}{2\pi\epsilon} \sum_{n=-\infty}^{n=\infty} \left[ -\ln \sqrt{x^2 + (y - 2nh)^2} + \ln \sqrt{x^2 + (y - 2a - 2nh)^2} \right]$$

**MATLAB solution:**

To plot the contour of the voltage, we can use the expression we derived to evaluate voltages at all plotting points, then store the voltages in a two-dimensional matrix.

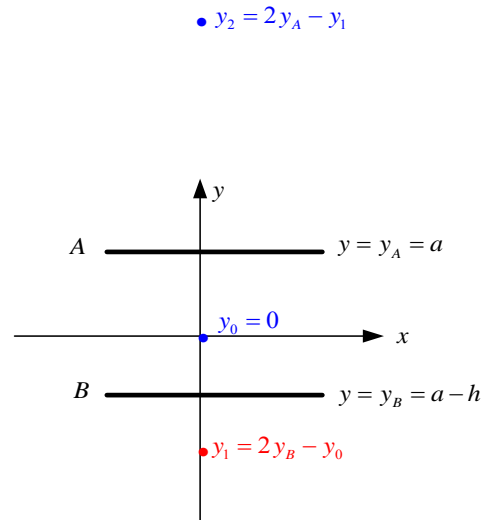


Figure 10.4 images of group 1.

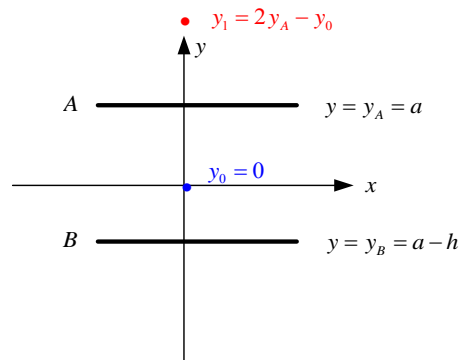


Figure 10.5 images of group 2.

**MATLAB code:**

```

clc; %clear the command window
clear; %clear all variables

a=1;%value of a
h=2;%value of h
rho_L=1.0e-7;
Epsilono=8.854e-12;%permittivity of free space
NumberOfXPlottingPoints=100; %number of plotting points along the x axis
NumberOfYPlottingPoints=100; %number of plotting points along the y axis
Negative_infinite=-40;%use a finite number to replace negative infinite
Positive_infinite=40;%use a finite number to replace positive infinite
V=zeros(NumberOfYPlottingPoints,NumberOfXPlottingPoints);% the matrix used to store the voltages at plotting
points
PlotXmin=a-h; %lowest x value on the plot plane
PlotXmax=a; %maximum x value on the plot plane
PlotYmin=PlotXmin; %lowest z value on the plot plane
PlotYmax=PlotXmax; %maximum z value on the plot plane
PlotStepX=(PlotXmax-PlotXmin)/(NumberOfXPlottingPoints-1);%plotting step in the x direction
PlotStepY=(PlotYmax-PlotYmin)/(NumberOfYPlottingPoints-1); %plotting step in the Y direction

[xmesh,ymesh] = meshgrid(PlotXmin:PlotStepX:PlotXmax,PlotYmin:PlotStepY:PlotYmax);%creates a mesh grid
for j=1:NumberOfYPlottingPoints %repeat for all plot points in the y direction
    for i=1:NumberOfXPlottingPoints %repeat for all plot points in the x direction
        xplot=PlotXmin+(i-1)*PlotStepX;%x coordinate of current plotting point
        yplot=PlotYmin+(j-1)*PlotStepY;%y coordinate of current plotting point
        P=[xplot yplot]; %position vector of current plotting point
        for n=Negative_infinite:Positive_infinite
            x1=0;%x coordinate of the image in the first term
            y1=2*n*h;%y coordinate of the image in the first term
            C1=[x1,y1];%position of the image in the first term
            x2=0;%x coordinate of the image in the second term
            y2=2*a+2*n*h;%y coordinate of the image in the second term
            C2=[x2 y2];%position of the image in the second term
        end
    end
end

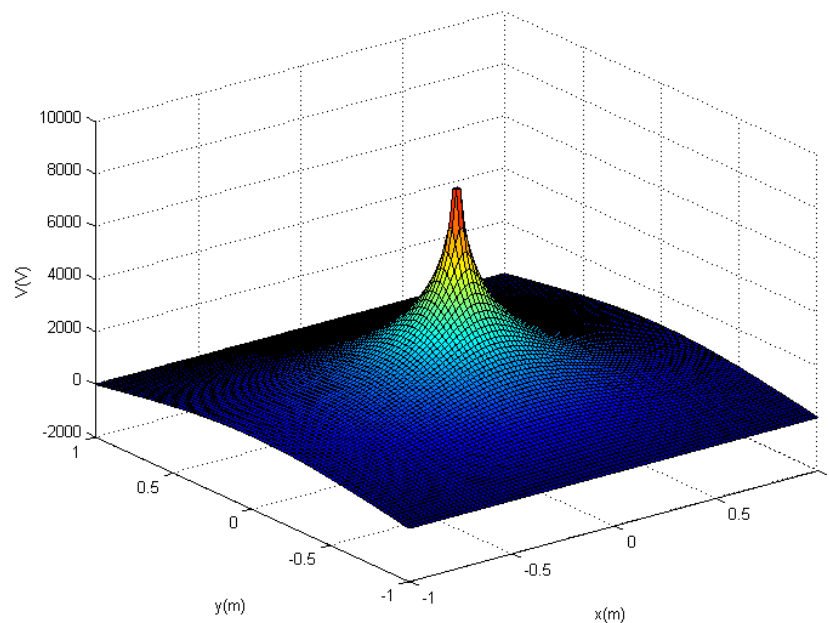
```

## MATLAB Examples and Exercises (Set 10)

```

R1=P-C1;%vector point from current plotting point to the image in the first term
R2=P-C2;%vector point from current plotting point to the image in the second term
R1mag=norm(R1);%the distance from current plotting point to the image in the first term
R2mag=norm(R2);%the distance from current plotting point to the image in the second term
V(j,i)=V(j,i)-rho_L*log(R1mag)/(2*pi*Epsilono)+rho_L*log(R2mag)/(2*pi*Epsilono);%get the voltage
contribution to current plotting point
    end
end
end
surf(xmesh,ymesh,V);%obtain the surface figure
xlabel('x(m)');% label x
ylabel('y(m)');% label y
zlabel('V(V)');% label z
figure;
[C,h] = contour(xmesh,ymesh,V);%obtain the contour figure
set(h,'ShowText','on','TextStep',get(h,'LevelStep'));%label the contour
xlabel('x(m)');% label x
ylabel('y(m)');% label y

```

**Running result:****Figure 10.6 3D surface of the voltage.**

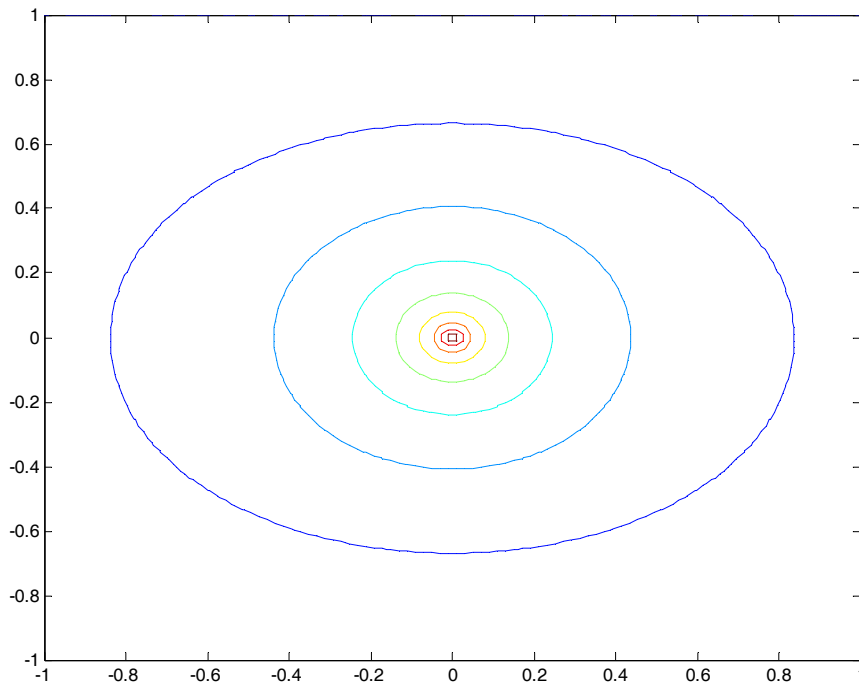


Figure 10.7 The voltage contours.

**Exercise:** A point charge  $Q$  and four conducting lines with zero potential are shown in Figure 10.8. Derive an expression for the voltage at any point  $(x, y)$ . If  $Q = 1.0 \mu\text{C}$  and  $a = 1.0 \text{ m}$ , use the expression you derived to write a MATLAB program that plot the contour of the voltage.

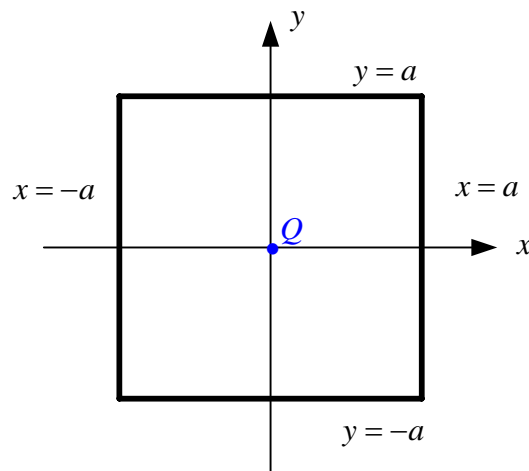


Figure 10.8 The charge distribution of the exercise of Set 10.

## ECE2FH3 Electromagnetics I

Term II, January – April 2012

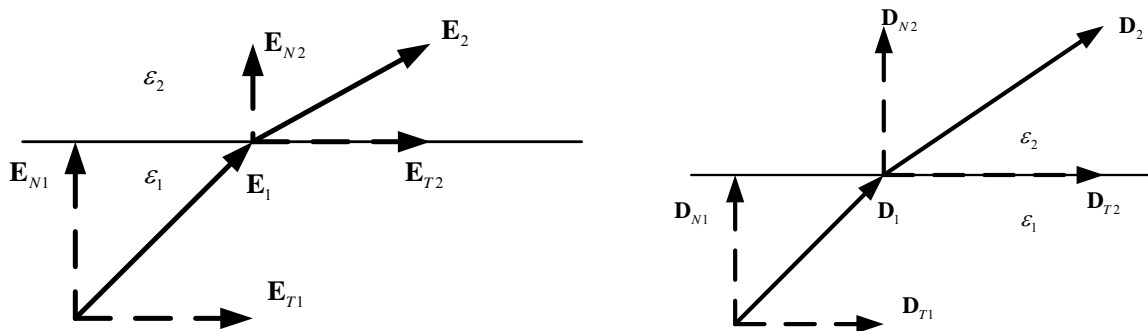
### MATLAB Examples and Exercises (Set 11)

Prepared by: Dr. M. H. Bakr and C. He

**Example:** Two perfect dielectrics have relative permittivities  $\epsilon_{r1} = 3$  and  $\epsilon_{r2} = 6$ . The planar interface between them is the surface  $x + y + 2z = 1$ . The origin lies in region 1. If  $\mathbf{E}_1 = 24.0 \mathbf{a}_x + 36.0 \mathbf{a}_y + 42.0 \mathbf{a}_z$  V/m, find  $\mathbf{E}_2$ . Write a MATLAB program to determine the field  $\mathbf{E}_2$  for arbitrary values of the permittivities  $\epsilon_{r1}$  and  $\epsilon_{r2}$ .

**Analytical solution:**

The electric field intensity is continuous in the tangential direction of the boundary and the electric flux density is continuous in the normal direction of the boundary.



**Figure 11.1** The continuity of the electric field intensity and the electric flux density vectors,  $\mathbf{E}_{T1} = \mathbf{E}_{T2}$  and  $\mathbf{D}_{N1} = \mathbf{D}_{N2}$ .

The unit vector that is normal to the surface is

$$\mathbf{a}_N = \frac{\nabla f}{|\nabla f|} \text{ where } f = x + y + 2z, \text{ therefore}$$

$$\mathbf{a}_N = \frac{\mathbf{a}_x + \mathbf{a}_y + 2\mathbf{a}_z}{|\mathbf{a}_x + \mathbf{a}_y + 2\mathbf{a}_z|} = \frac{1}{\sqrt{6}}(\mathbf{a}_x + \mathbf{a}_y + 2\mathbf{a}_z)$$

This normal will point in the direction of increasing  $f$ , which will be away from origin, or into region 2. Then we can find the electric field intensity in region 1. The normal component is given by

$$\mathbf{E}_{N1} = (\mathbf{E}_1 \cdot \mathbf{a}_N) \mathbf{a}_N = \left[ (24\mathbf{a}_x + 36\mathbf{a}_y + 42\mathbf{a}_z) \cdot \frac{1}{\sqrt{6}}(\mathbf{a}_x + \mathbf{a}_y + 2\mathbf{a}_z) \right] \times \frac{1}{\sqrt{6}}(\mathbf{a}_x + \mathbf{a}_y + 2\mathbf{a}_z) = 24\mathbf{a}_x + 24\mathbf{a}_y + 48\mathbf{a}_z$$

Now we can calculate the tangential component

$$\mathbf{E}_{T1} = \mathbf{E}_1 - \mathbf{E}_{N1} = (24\mathbf{a}_x + 36\mathbf{a}_y + 42\mathbf{a}_z) - (24\mathbf{a}_x + 24\mathbf{a}_y + 48\mathbf{a}_z) = 12\mathbf{a}_y - 6\mathbf{a}_z .$$

Since the electric field intensity is continuous in the tangential direction of the boundary, we have

$$\mathbf{E}_{T2} = \mathbf{E}_{T1} = 12\mathbf{a}_y - 6\mathbf{a}_z .$$

In the normal direction, the electric flux density is continuous, hence

$$\mathbf{D}_{N1} = \mathbf{D}_{N2} \Rightarrow \epsilon_{r1}\epsilon_0\mathbf{E}_{N1} = \epsilon_{r2}\epsilon_0\mathbf{E}_{N2} \Rightarrow \mathbf{E}_{N2} = \frac{\epsilon_{r1}}{\epsilon_{r2}}\mathbf{E}_{N1} = \frac{3}{6}(24\mathbf{a}_x + 24\mathbf{a}_y + 48\mathbf{a}_z) = 12\mathbf{a}_x + 12\mathbf{a}_y + 24\mathbf{a}_z$$

Finally, by adding the normal component and the tangential component together, we find the electric field in region 2,

$$\mathbf{E}_2 = \mathbf{E}_{T2} + \mathbf{E}_{N2} = (12\mathbf{a}_y - 6\mathbf{a}_z) + (12\mathbf{a}_x + 12\mathbf{a}_y + 24\mathbf{a}_z) = 12\mathbf{a}_x + 24\mathbf{a}_y + 18\mathbf{a}_z \text{ V/m.}$$

### MATLAB code:

```

clc; %clear the command line
clear; %remove all previous variables
aN=[1 1 2]/sqrt(6); % unit vector normal to the planar interface
% prompt for input values
disp('Please enter E1, er1 and er2 ')
E1=input('E1='); % the electric field intensity in region 1
er1=input('er1='); % the relative permittivity in region 1
er2=input('er2='); % the relative permittivity in region 2
% perform calculations
E_N1=(dot(E1,aN))*aN; % the normal component of electric field intensity in region 1
E_T1=E1-E_N1; % the tangential component of electric field intensity in region 1
E_T2=E_T1; % the tangential component of electric field intensity in region 2
E_N2=E_N1*er1/er2; % the normal component of electric field intensity in region 2
E2=E_T2+E_N2; % the electric field intensity in region 2
% display results
disp('The electric field intensity in region 2 is ')
E2

```

### Running result:

```

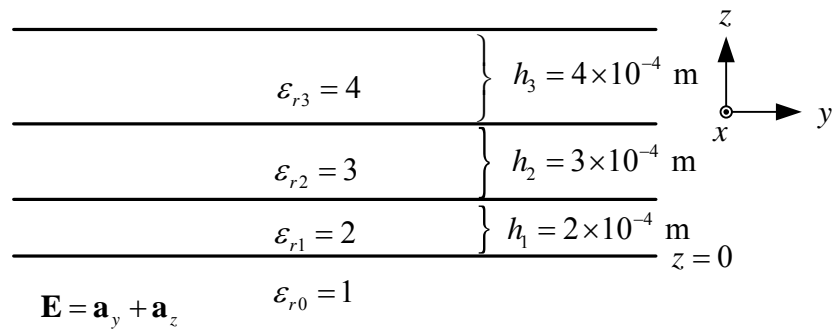
Please enter E1, er1 and er2
E1=[24 36 42]
er1=3
er2=6
The electric field intensity in region 2 is

E2 =

    12.0000    24.0000    18.0000

```

**Exercise:** In the region  $z < 0$ , the relative permittivity is  $\epsilon_{r0} = 1$ , and the electric field intensity is  $\mathbf{E} = 1.0 \mathbf{a}_y + 1.0 \mathbf{a}_z$  V/m. In the region  $0 < z < 9$  cm, there are four layers of different dielectrics, as shown in Figure 11.2. Find the total energy stored in the region bounded by  $0 \leq x \leq 1 \times 10^{-2}$  m,  $0 \leq y \leq 1 \times 10^{-2}$  m, and  $0 \leq z \leq 9 \times 10^{-2}$  m. Write a MATLAB program to verify your calculation.



**Figure 11.2** The geometry of the exercise of Set 11.



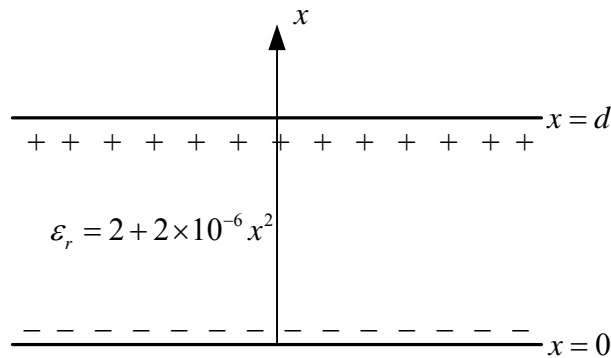
## ECE2FH3 Electromagnetics I

Term II, January – April 2012

### MATLAB Examples and Exercises (Set 12)

Prepared by: Dr. M. H. Bakr and C. He

**Example:** A parallel-plate is filled with a nonuniform dielectric characterized by  $\epsilon_r = 2 + 2 \times 10^6 x^2$ , where  $x$  is the distance from the lower plate in meters. If  $S = 0.02 \text{ m}^2$  and  $d = 1.0 \text{ mm}$ , find the capacitance  $C$ . Write a MATLAB program that finds the energy stored in this capacitor if the charge on the positive plate is  $Q = 4.0 \times 10^{-9} \text{ C}$ . Use the formula  $W_E = Q^2 / 2C$  to evaluate the capacitance and compare your results.



**Figure 12.1** The geometry of the example of Set 12.

#### Analytical solution:

We can use the  $Q$ -method to find the capacitance. This can be done by first assuming a total charge of  $Q$  on the positive plate and then finding the potential difference  $V$  between the two plates. Finally, we can evaluate the capacitance by using  $C=Q/V$ . A total charge of  $Q$  is on the positive plate, and since the plate can be seen as an infinite plate ( $\sqrt{S} \gg d$ ), we can simply assume a uniform charge density on the plates. The electric flux density is given by

$$\mathbf{D} = -\frac{Q}{S} \mathbf{a}_x$$

and the electric field intensity is given by

$$\mathbf{E} = \frac{\mathbf{D}}{\epsilon_r \epsilon_0} = -\frac{Q}{\epsilon_r \epsilon_0 S} \mathbf{a}_x.$$

By knowing the electric field intensity we can find the voltage difference between the two plates,

$$V = -\int_{x=0}^{x=d} \mathbf{E} \cdot d\mathbf{L} = -\int_{x=0}^{x=d} -\frac{Q}{\epsilon_r \epsilon_0 S} \mathbf{a}_x \cdot (\mathbf{a}_x dx) = \frac{Q}{\epsilon_0 S} \int_{x=0}^{x=d} \frac{1}{2 + 2 \times 10^6 x^2} dx = \frac{Q}{\epsilon_0 S} \times \frac{1}{\sqrt{10^{-6}}} \arctan\left(\frac{x}{\sqrt{10^{-6}}}\right) \Bigg|_{x=0}^{x=d}$$

$$= \frac{Q}{2000\epsilon_0 S} \arctan(1000d)$$

Now, we can find the capacitance

$$C = \frac{Q}{V} = \frac{Q}{\frac{Q}{2000\epsilon_0 S} \arctan(1000d)} = \frac{2000\epsilon_0 S}{\arctan(1000d)} = \frac{2000 \times \frac{1}{36\pi} \times 10^{-9} \times 0.02}{\arctan(1000 \times 10^{-3})} = 4.503 \times 10^{-10} \text{ C}$$

#### MATLAB solution:

We will write a MATLAB program to find the energy stored in the capacitance then use the formula  $W_E = Q^2 / 2C$  to evaluate the capacitance. The energy stored in the capacitor is given by

$$W_E = \frac{1}{2} \int_{\text{vol}} \epsilon_r \epsilon_0 E^2 dv = \frac{1}{2} \int_{\text{vol}} \frac{D^2}{\epsilon_r \epsilon_0} dv = \frac{1}{2} \int_{\text{vol}} \frac{D^2}{\epsilon_r \epsilon_0} dv$$

Consider a very thin layer of this capacitor. Since the relative dielectric  $\epsilon_r$  varies only in the  $x$  direction, we can assume the dielectric is the same everywhere in the very thin layer. Also we note that the electric flux density is constant along the  $x$  direction. Therefore we can write a program that divides the capacitor into many thin layers and evaluate the energy stored in each layer. We then add all the energy stored in these layers together to obtain the total energy stored in the capacitor. By knowing the energy stored in the capacitor, we can calculate the capacitance by using  $C = Q^2 / 2W_E$

#### MATLAB code:

```

clc; %clear the command line
clear; %remove all previous variables
% initialize variables
eo=1e-9/(36*pi); % the permittivity in free space
Q=4e-9; % charges on the positive plate
S=0.02; % area of the capacitor
d=1e-3; % thickness of the capacitor
Ds=Q/S; % electric flux density
Number_of_x_steps=100; %number of steps in the x direction
dx=d/Number_of_x_steps; %x increment
% perform calculations
W=0; % initialize the total energy
for k=1:Number_of_x_steps
    x=0.5*dx+(k-1)*dx; %current radius
    er=2+2*x*x*1e6; %current relative permittivity
    dW=0.5*Dx*Dx*S*dx/(er*eo); % energy stored in a thin layer
    W=W+dW; % get contribution to the total energy
end
C=Q^2/(2*W)

```

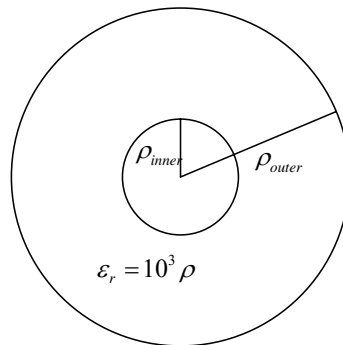
**Running result:**

C =

4.5032e-010

Comparing the answers we see that our MATLAB solution and analytical solution are consistent.

**Exercise:** A very long coaxial capacitor has an inner radius of  $\rho_{inner} = 1.0 \times 10^{-3}$  m and an outer radius of  $\rho_{outer} = 5.0 \times 10^{-3}$  m. It is filled with a nonuniform dielectric characterized by  $\epsilon_r = 10^3 \rho$ . Find the capacitance of a 0.01 m long capacitor of this kind. Write a MATLAB program that finds the energy stored in this capacitor if the charge on the inner plate is  $Q = 5.0 \times 10^{-9}$  C. Use the formula  $W_E = Q^2 / 2C$  to evaluate the capacitance again and compare your results.



**Figure 12.2** The cross section of the coaxial capacitor of the exercise of Set 12.

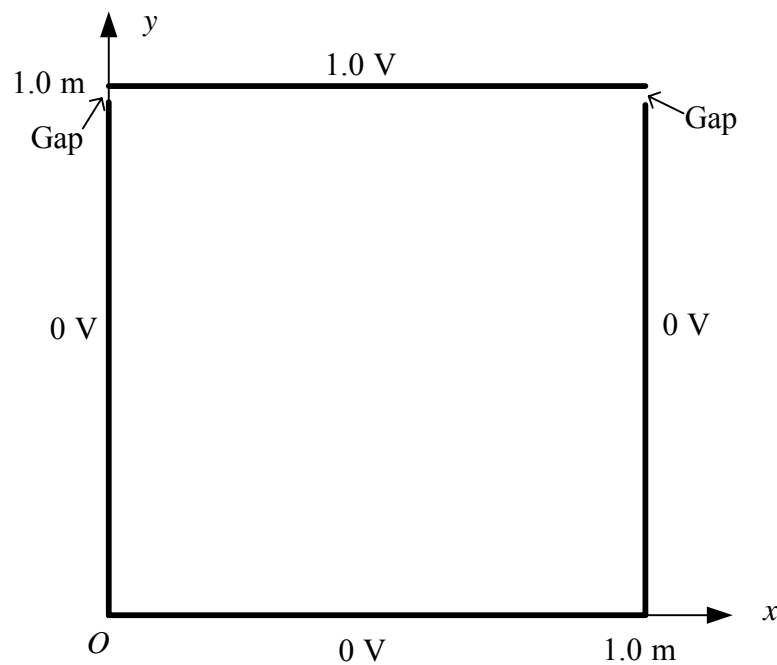
**ECE2FH3****Electromagnetics I**

Term II, January – April 2012

**MATLAB Examples and Exercises (Set 13)**

Prepared by: Dr. M. H. Bakr and C. He

**Example:** Consider the configuration of conductors and potentials shown in Figure 13.1. Derive an expression for the voltage at any point  $(x, y)$  inside the conductors. Write a MATLAB program that plots the contours of the voltage and the lines of the electric field.



**Figure 13.1** The configuration of the example of Set 13.

**Analytical solution:**

The governing equation is the Laplace equation given by:

$$\frac{\partial^2 V}{\partial x^2} + \frac{\partial^2 V}{\partial y^2} = 0, \quad 0 < x < 1.0, \quad 0 < y < 1.0$$

$$V(0, y) = 0, \quad V(1.0, y) = 0;$$

$$V(x, 0) = 0, \quad V(x, 1.0) = 1.0$$

Let  $V = XY$  be the solution of  $\frac{\partial^2 V}{\partial x^2} + \frac{\partial^2 V}{\partial y^2} = 0$ , where  $X$  is a function of  $x$  and  $Y$  is a function of  $y$ . It follows

that we have

$$\frac{\partial^2 V}{\partial x^2} + \frac{\partial^2 V}{\partial y^2} = X''Y + XY'' = 0$$

$$\frac{X''}{X} = -\frac{Y''}{Y} = -\lambda^2$$

$$X'' + \lambda^2 X = 0$$

$$Y'' - \lambda^2 Y = 0$$

$$X = c_1 \cos \lambda x + c_2 \sin \lambda x$$

$$Y = c_3 \cosh \lambda y + c_4 \sinh \lambda y$$

Boundary condition  $V(0, y) = 0$  indicates  $V(0, y) = X(0)Y = 0, \Rightarrow X(0) = c_1 \cos 0 + c_2 \sin 0 = 0 \Rightarrow c_1 = 0$

therefore  $X = c_2 \sin \lambda x$  (1)

Boundary condition  $V(1.0, y) = 0$  indicates  $V(1.0, y) = X(1.0)Y = 0, \Rightarrow X(1.0) = c_2 \sin \lambda = 0 \Rightarrow \lambda = n\pi$  (2)

Boundary condition  $V(x, 0) = 0$  indicates  $V(x, 0) = XY(0) = 0, \Rightarrow Y(0) = c_3 \cosh \lambda = 0 \Rightarrow c_3 = 0$ , therefore

$$Y = c_4 \sinh \lambda y$$
 (3)

With equation (1), (2) and (3), we have

$$V_n = X_n Y_n = A_n \sin(n\pi x) \sinh(n\pi y).$$

The general solution for the Laplace equation is thus given by

$$V = \sum_{n=1}^{\infty} A_n \sinh(n\pi y) \sin(n\pi x)$$

Now, the last boundary condition  $V(x, 1.0) = 1.0$  indicates that

$$V(x, 1.0) = \sum_{n=1}^{\infty} A_n \sinh(n\pi) \sin(n\pi x) = 1.0.$$

Multiplying both sides by  $\sin(n\pi x)$  and integrating

$$\Rightarrow A_n \sinh(n\pi) = 2 \int_0^{1.0} \sin(n\pi x) dx = \frac{-2 \cos(n\pi x)}{n\pi} \Big|_{x=0}^{x=1} = \frac{2 - 2 \cos(n\pi)}{n\pi} = \frac{2 - 2 \times (-1)^n}{n\pi} \Rightarrow A_n = \frac{2 - 2 \times (-1)^n}{n\pi \sinh(n\pi)}$$

Therefore,

$$V = \sum_{n=1}^{\infty} \frac{2 - 2 \times (-1)^n}{n\pi \sinh(n\pi)} \sinh(n\pi y) \sin(n\pi x)$$

**MATLAB code:**

```

NumberOfXPlottingPoints=40; %number of plotting points along the x axis
NumberOfYPlottingPoints=40; %number of plotting points along the y axis
Positive_infinite=160;%use a finite number to replace positive infinite
V=zeros(NumberOfYPlottingPoints,NumberOfXPlottingPoints);% the matrix used to store the voltages at plotting points
PlotXmin=0; %lowest x value on the plot plane
PlotXmax=1; %maximum x value on the plot plane
PlotYmin=0; %lowest y value on the plot plane
PlotYmax=1; %maximum y value on the plot plane
PlotStepX= (PlotXmax-PlotXmin)/(NumberOfXPlottingPoints-1);%plotting step in the x direction
PlotStepY=(PlotYmax-PlotYmin)/(NumberOfYPlottingPoints-1); %plotting step in the y direction
[xmesh,ymesh] = meshgrid(PlotXmin:PlotStepX:PlotXmax,PlotYmin:PlotStepY:PlotYmax);
for j=1:NumberOfYPlottingPoints %repeat for all plot points in the y direction
    for i=1:NumberOfXPlottingPoints %repeat for all plot points in the x direction
        xplot=PlotXmin+(i-1)*PlotStepX;%x coordinate of current plotting point
        yplot=PlotYmin+(j-1)*PlotStepY;%y coordinate of current plotting point
        for n=1:Positive_infinite
            V(j,i)=V(j,i)+(2-2*(-1)^n)*sinh(n*pi*yplot)*sin(n*pi*xplot)/(n*pi*sinh(n*pi));%get the voltage contribution
        end
    end
end
surf(xmesh,ymesh,V);%obtain the surface figure
xlabel('x(m)');% label x
ylabel('y(m)');% label y
zlabel('V(V)');% label z
figure;
[C,h] = contour(xmesh,ymesh,V);%obtain the contour figure
set(h,'ShowText','on','TextStep',get(h,'LevelStep'));%label the contour
xlabel('x(m)');% label x
ylabel('y(m)');% label y
figure;
contour(xmesh,ymesh,V); [px,py] = gradient(V);
hold on,quiver(xmesh,ymesh,-px,-py,3),hold off,%obtain the electric field map by using E=-Gradient(V)
xlabel('x(m)');% label x
ylabel('y(m)');% label

```

Running result:

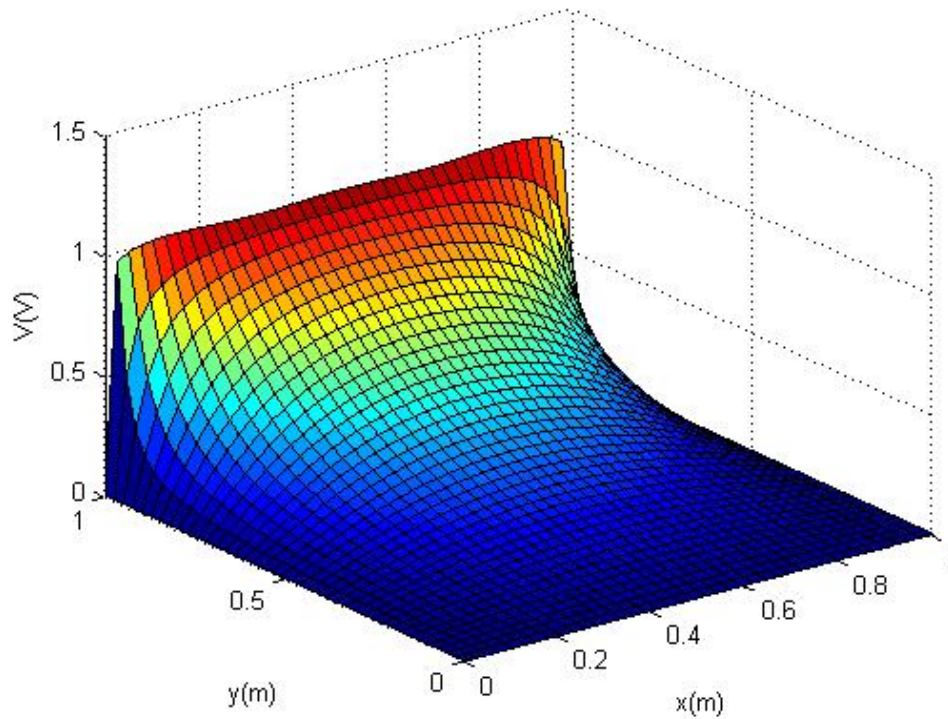


Figure 13.2 The surface of the voltage in the region  $0 < x < 1$ , and  $0 < y < 1$ .

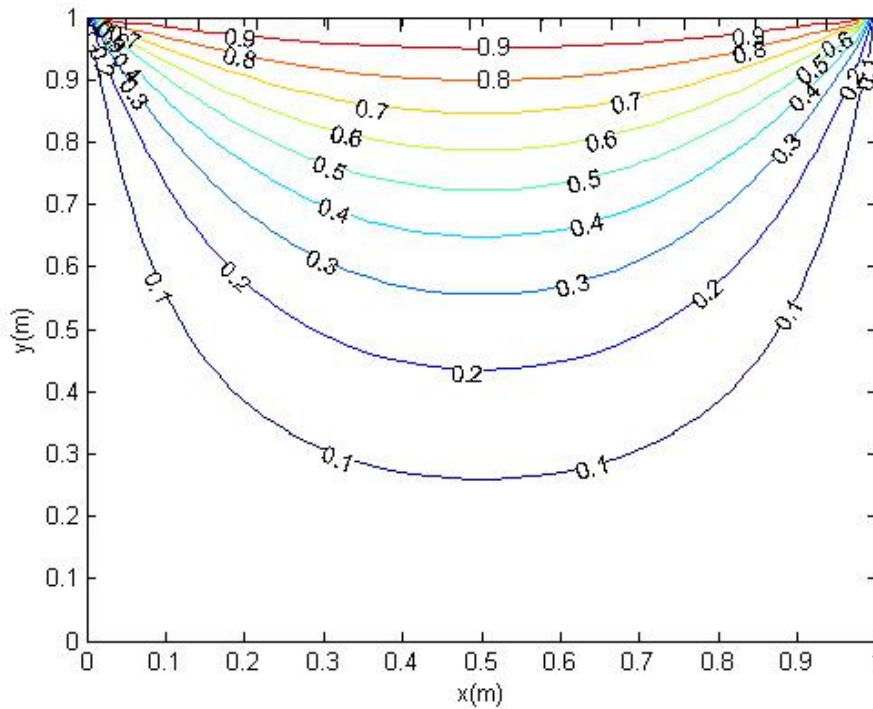


Figure 13.3 Contours of the voltage in the region  $0 < x < 1$ , and  $0 < y < 1$ .

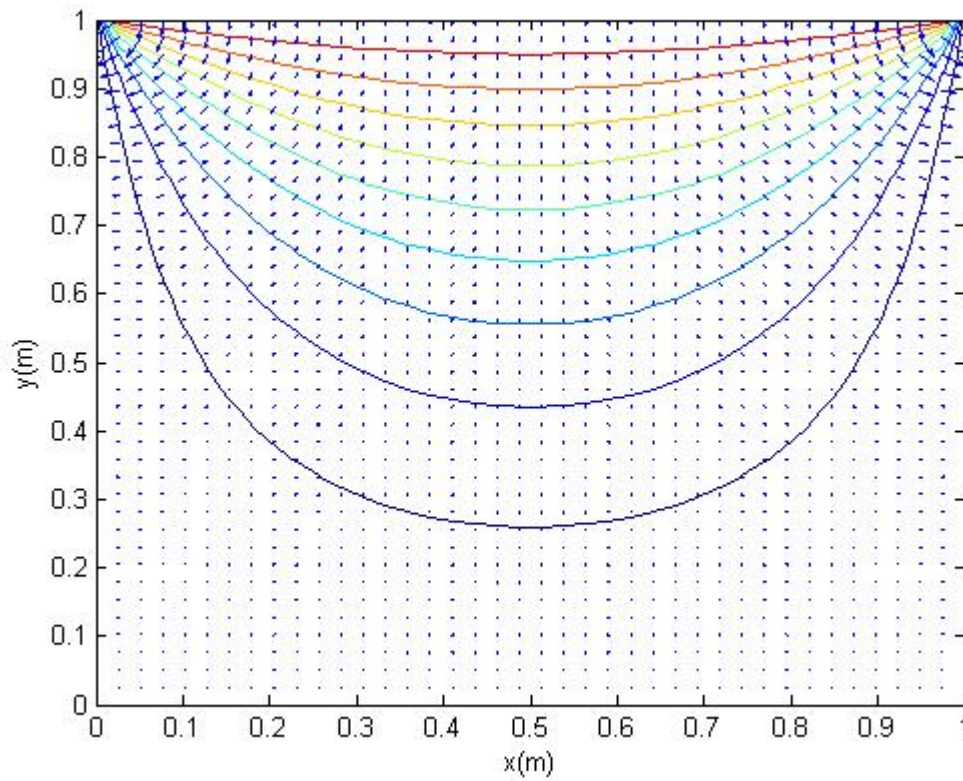


Figure 13.4 The electric field lines in the region  $0 < x < 1$ , and  $0 < y < 1$ .



## MATLAB Examples and Exercises (Set 13)

**Exercise:** Consider the configuration of conductors and potentials shown in Figure 13.2. Derive an expression for the voltage at any point  $(x, y)$  inside the conductors. Write a MATLAB program that plots the contours of the voltage and the lines of the electric field.

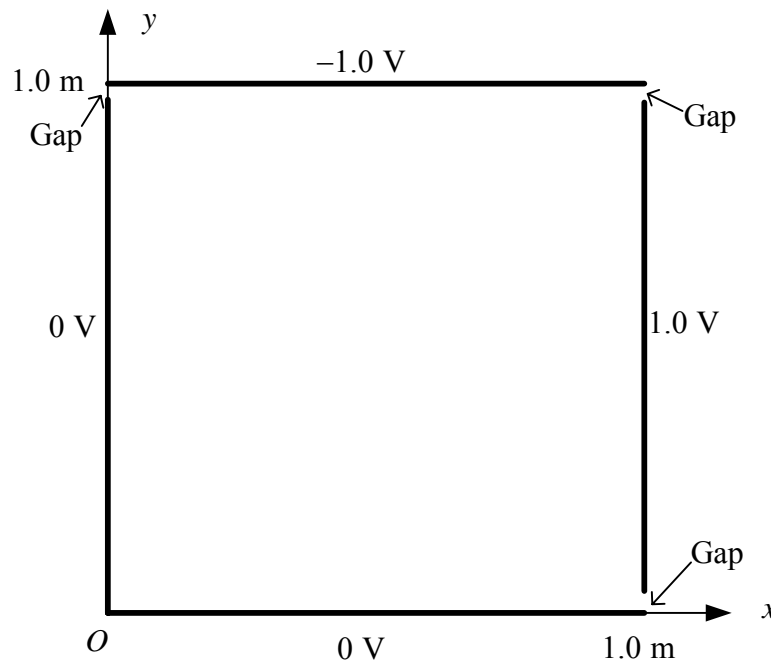


Figure 13.5 The geometry of the exercise of Set 13.

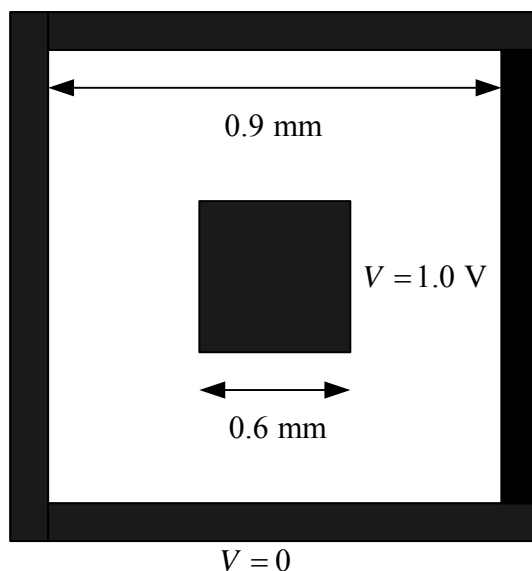
**ECE2FH3****Electromagnetics I**

Term II, January – April 2012

**MATLAB Examples and Exercises (Set 14)**

Prepared by: Dr. M. H. Bakr and C. He

**Example:** Consider the shown cross section of a square coaxial cable. The inner conductor has a voltage of 1.0 V while the outer conductor is grounded. The cable is assumed long enough and variations in potential and field in the normal direction can be ignored (2D problem). Write a MATLAB program that solves Laplace equation in the area between the two conductors. Plot the contours of the voltage and the lines of the electric field.

**Figure 14.1** The geometry of the example of Set 14.

**Analytical solution:** The governing equation is the Laplace equation:

$$\frac{\partial^2 V}{\partial x^2} + \frac{\partial^2 V}{\partial y^2} = 0$$

$$\left. \frac{\partial V}{\partial x} \right|_a = \frac{V_1 - V_0}{h}$$

$$\left. \frac{\partial V}{\partial x} \right|_c = \frac{V_0 - V_3}{h}$$

$$\left. \frac{\partial^2 V}{\partial x^2} \right|_0 = \frac{\left. \frac{\partial V}{\partial x} \right|_a - \left. \frac{\partial V}{\partial x} \right|_c}{h} = \frac{V_1 + V_3 - 2V_0}{h^2}$$

and similarly,

$$\left. \frac{\partial^2 V}{\partial y^2} \right|_0 = \frac{V_2 + V_4 - 2V_0}{h^2}$$

Substituting in Laplace equation

$$\left. \frac{\partial^2 V}{\partial x^2} \right|_0 + \left. \frac{\partial^2 V}{\partial y^2} \right|_0 = \frac{V_1 + V_2 + V_3 + V_4 - 4V_0}{h^2} = 0$$

or

$$V_0 = \frac{V_1 + V_2 + V_3 + V_4}{4}$$

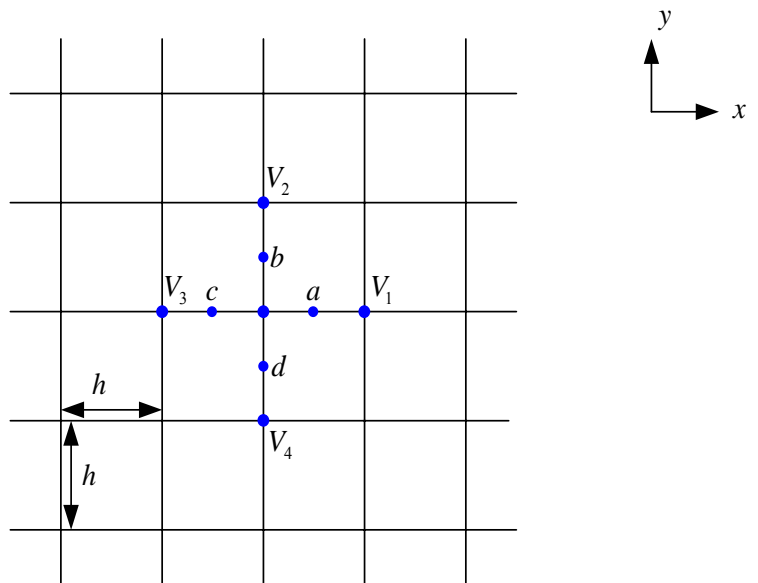
$$-4V_0 + V_1 + V_2 + V_3 + V_4 = 0 \quad (1)$$

For points on the inner square of the cable, the voltage is given by

$$V_0 = 1.0 \quad (2)$$

Then we can obtain a system of linear equations whose unknowns are the voltages of the points inside the cable. Assume there are  $n$  divisions along the  $x$  direction and  $m$  divisions along the  $y$  direction, then we have total number of  $m \times n$  linear equations, and the system of linear equations is given by

$$\begin{pmatrix} a_{1,1} & a_{1,2} & a_{1,3} & \cdots & \cdots & \cdots & a_{1,m \times (n-2)} & a_{1,m \times (n-1)} & a_{1,m \times n} \\ a_{2,1} & a_{2,2} & a_{2,3} & \cdots & \cdots & \cdots & a_{2,m \times (n-2)} & a_{2,m \times (n-1)} & a_{2,m \times n} \\ a_{3,1} & a_{3,2} & a_{3,3} & \cdots & \cdots & \cdots & a_{3,m \times (n-2)} & a_{3,m \times (n-1)} & a_{3,m \times n} \\ \vdots & \vdots & \vdots & \vdots & \vdots & \vdots & \vdots & \vdots & \vdots \\ \vdots & \vdots & \vdots & \vdots & \vdots & \vdots & \vdots & \vdots & \vdots \\ \vdots & \vdots & \vdots & \vdots & \vdots & \vdots & \vdots & \vdots & \vdots \\ a_{m \times (n-2),1} & a_{m \times (n-2),2} & a_{m \times (n-2),3} & \cdots & \cdots & \cdots & a_{m \times (n-2),m \times (n-2)} & a_{m \times (n-2),m \times (n-1)} & a_{m \times (n-2),m \times n} \\ a_{m \times (n-1),1} & a_{m \times (n-1),2} & a_{m \times (n-1),3} & \cdots & \cdots & \cdots & a_{m \times (n-1),m \times (n-2)} & a_{m \times (n-1),m \times (n-1)} & a_{m \times (n-1),m \times n} \\ a_{m \times n,1} & a_{m \times n,2} & a_{m \times n,3} & \cdots & \cdots & \cdots & a_{m \times n,m \times (n-2)} & a_{m \times n,m \times (n-1)} & a_{m \times n,m \times n} \end{pmatrix} \begin{pmatrix} V_1 \\ V_2 \\ V_3 \\ \vdots \\ \vdots \\ \vdots \\ V_{m \times (n-2)} \\ V_{m \times (n-1)} \\ V_{m \times n} \end{pmatrix} = \begin{pmatrix} b_1 \\ b_2 \\ b_3 \\ \vdots \\ \vdots \\ \vdots \\ b_{m \times (n-1)} \\ b_{m \times (n-1)} \\ b_{m \times n} \end{pmatrix}$$



**Figure 14.2** A portion of a region containing a two-dimensional potential field, divided into square of side  $h$ . The potential  $V_0$  is approximately equal to the average of the potentials at the four neighboring points.

MATLAB Examples and Exercises (Set 14)

This system of linear equations can be solved through a MATLAB program. The key point of writing a MATLAB program is to construct the matrix  $A$  and the vector  $b$ . Figure 14.3 explains the construction of the matrix  $A$  and the vector  $b$ . In Figure 14.3(a), the point  $i$  is near the upper left corner of the cable. The voltage of this point is the average of the four neighboring points,

$$V_{out} + V_{out} + V_{i+1} + V_{i+n} - 4V_i = 0, \text{ or } V_{i+1} + V_{i+n} - 4V_i = 2V_{out}.$$

Now, in the matrix  $A$ ,  $a_{i,i} = -4$  because  $a_{i,i}$  is the coefficient of  $V_i$ . Also,  $a_{i,i+1} = 1$ ,  $a_{i,i+n} = 1$  because  $a_{i,i+1}$  and  $a_{i,i+n}$  are the coefficients of  $V_{i+1}$  and  $V_{i+n}$ , respectively. In the vector  $b$ ,  $b_i$  is assigned a value of  $2V_{out}$  which is the constant on the right hand of the equation. Other possible locations of a point inside the cable are shown in Figure 14.3 (b), (c), and (d). Our MATLAB create equations for all the points inside the cable and store the corresponding coefficients in  $A$  and  $b$ . The voltages of all the points inside the cable can be evaluated.

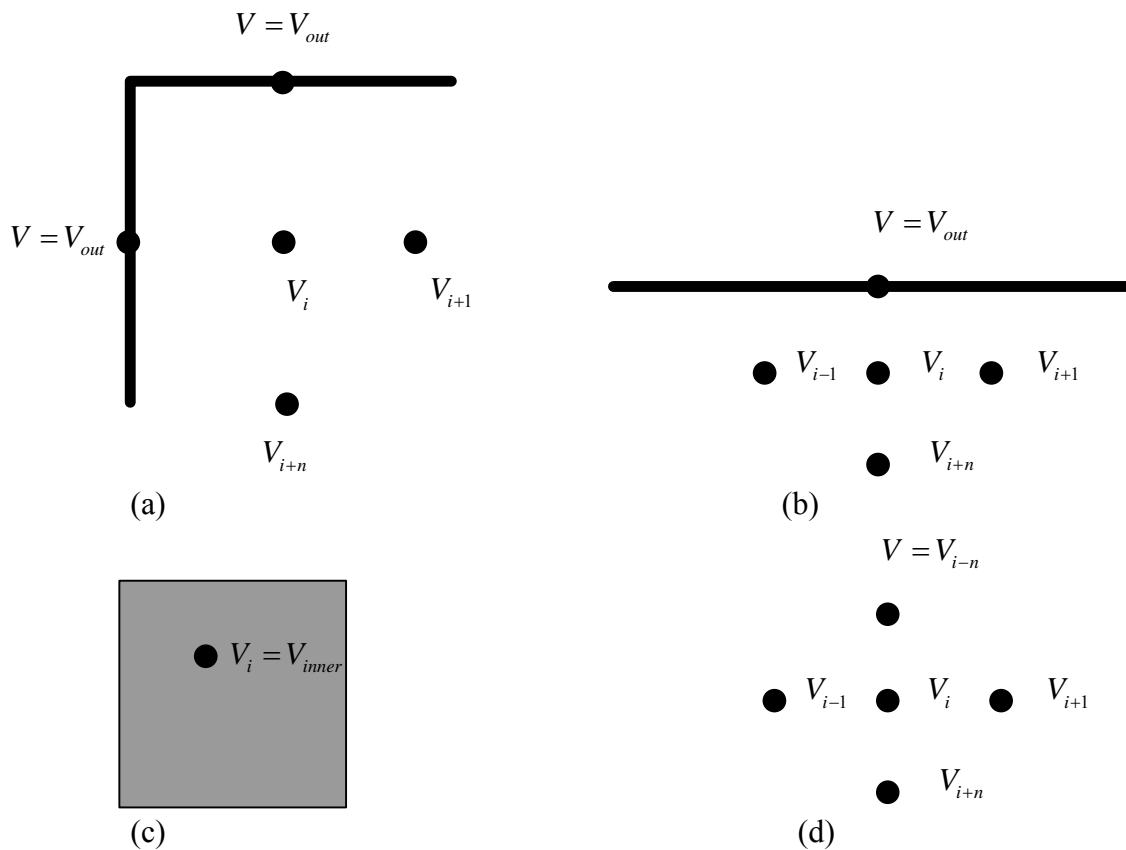


Figure 14.3(a)  $V_i$  is the voltage on the left corner of the cable; (b)  $V_i$  is the voltage on the top of the cable; (c)  $V_i$  is a nodal voltage inside the inner square of the cable; and (d)  $V_i$  is the voltage of a point inside the cable that is not next to the boundary.

**MATLAB code:**

```

VOut=0;%voltage on outer conductor
VIn=1.0;%voltage on inner conductor
NumberOfXPoints=50; %number of points in the x direction
NumberOfYPoints=NumberOfXPoints; %number of points in the y direction
NumberOfUnKnowns=NumberOfXPoints*NumberOfYPoints; %this is the total number of unknowns
A=zeros(NumberOfUnKnowns, NumberOfUnKnowns); %this is the matrix of coefficients
b=zeros(NumberOfUnKnowns,1);%this is the right hand side vector
jleft=(NumberOfXPoints+1)/3;%index of inner conductor left side
jright=2*jleft;%index of inner conductor right side
ibottom=(NumberOfYPoints+1)/3;%index of inner conductor Bottom side
itop=2*itop;%index of inner conductor Top side
EquationCounter=1; %this is the counter of the equations
for i=1:NumberOfXPoints %repeat for all rows
    for j=1:NumberOfYPoints %repeat for all columns
        if((i>=ibottom&i<=itop)&(j>=jleft&j<=jright))%V=1 for all points inside the inner conductor
            A(EquationCounter, EquationCounter)=1;
            b(EquationCounter,1)=VIn;
        else
            A(EquationCounter, EquationCounter)=-4;
            if(j==1) this is the first column
                b(EquationCounter, 1)=b(EquationCounter,1)-VOut; % left point is on boundary
            else%store the coefficient of the left point
                A(EquationCounter,EquationCounter-1)=1.0;
            end
            if(j==NumberOfYPoints) % this is the last column
                b(EquationCounter, 1)= b(EquationCounter,1)-VOut;%on right boundary
            else %store coefficient of right boundary
                A(EquationCounter, EquationCounter+1)=1.0;
            end
            if(i==1) % this is the first row
                b(EquationCounter,1)=b(EquationCounter,1)-VOut; %top point is on boundary
            else %store coefficient of top point
                A(EquationCounter, EquationCounter-NumberOfXPoints)=1;
            end
            if(i==NumberOfXPoints) % this is the last row
                b(EquationCounter,1)=b(EquationCounter,1)-VOut; %bottom point is on boundary
            else%store coefficient of bottom point

```

```

A(EquationCounter, EquationCounter+NumberOfXPoints)=1.0;
end
end
EquationCounter=EquationCounter+1;
end
end
V=A\b; %obtain the vector of voltages
V_Square=reshape(V, NumberOfXPoints, NumberOfYPoints);%convert values into a rectangular matrix
surf(V_Square); %obtain the surface figure
figure;
[C,h] = contour(V_Square);% obtain the contour figure
set(h,'ShowText','on','TextStep',get(h,'LevelStep')*2)
colormap cool;
figure;
contour(V_Square);
[px,py] = gradient(V_Square);
hold on, quiver(-px,-py), hold off%obtain the electric field map by using E=-Gradient(V)

```

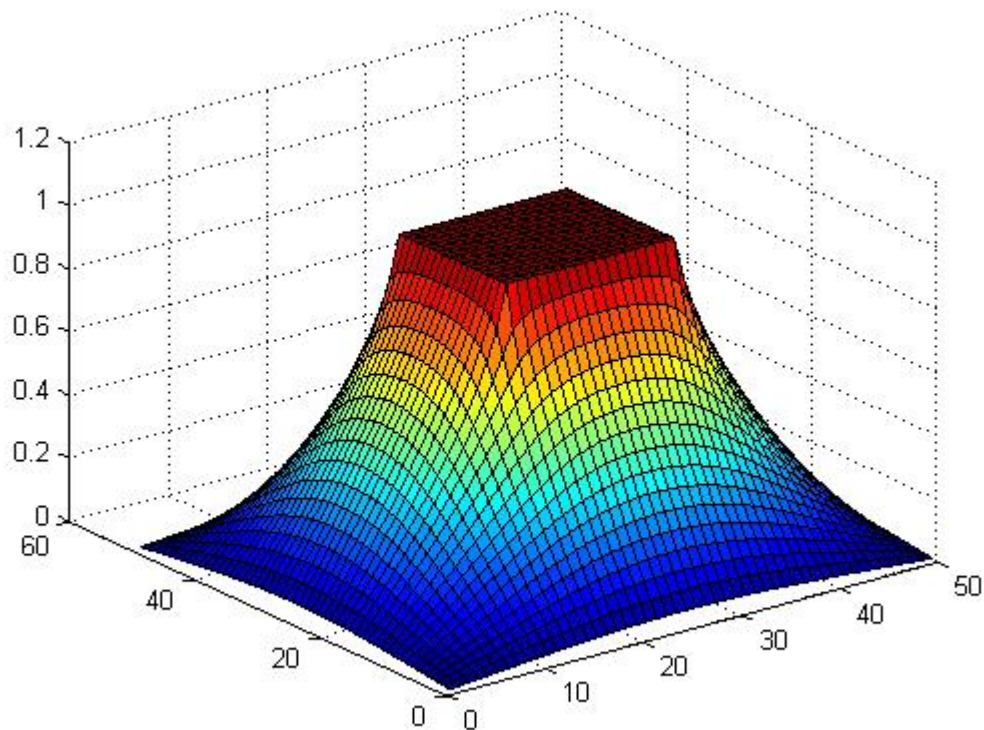
**Running result:**

Figure 14.4 The surface of the voltage inside the cable.

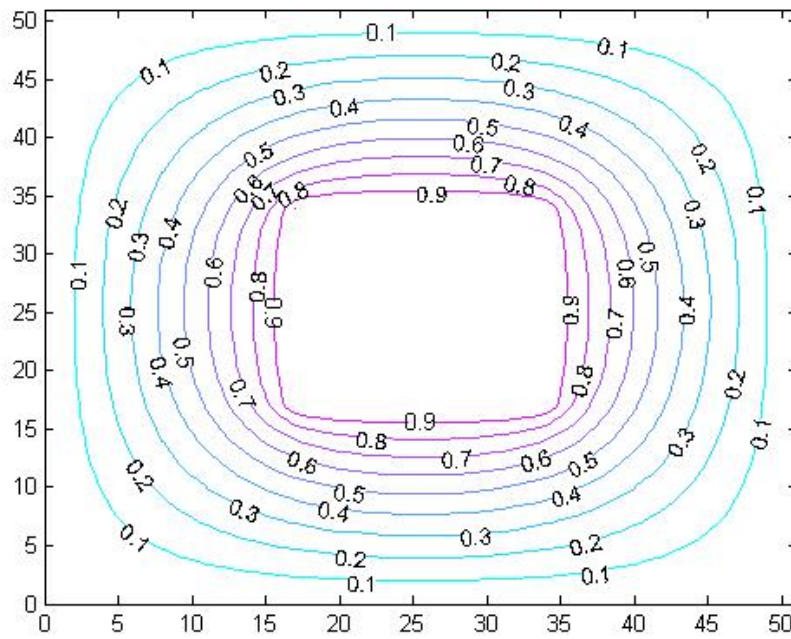


Figure 14.5 Contours of the voltage inside the cable.

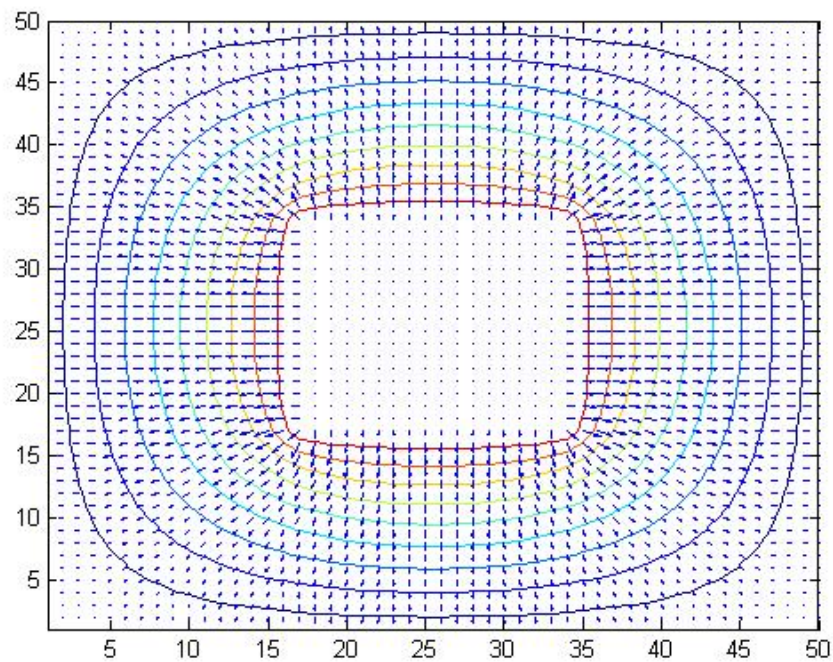


Figure 14.6 Electric field lines inside the cable.

## MATLAB Examples and Exercises (Set 14)

**Exercise:** Consider the configuration of conductors and potentials shown in Figure 14.7. Write a MATLAB program that solves Laplace equation in the area bounded by the conductors. Plot the contours of the voltage and the lines of the electric field.

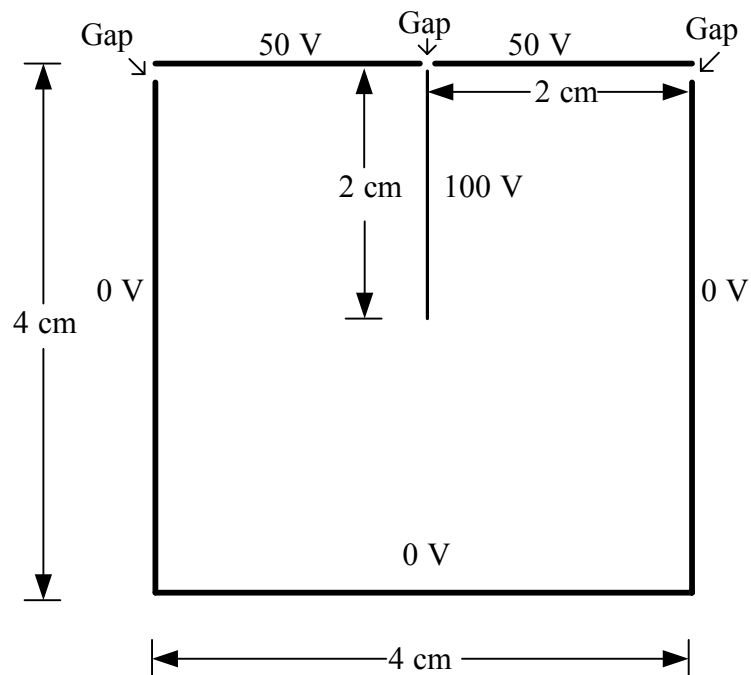


Figure 14.7 The configuration of the exercise of Set 14.



## ECE2FH3 Electromagnetics I

Term II, January – April 2012

### MATLAB Examples and Exercises (Set 15)

Prepared by: Dr. M. H. Bakr and C. He

**Example:** A current sheet  $\mathbf{K} = 5.0 \mathbf{a}_y$  A/m flows in the region  $-0.15 \text{ m} < x < 0.15 \text{ m}$ . Calculate  $\mathbf{H}$  at  $P(0,0,0.25)$ . Write a MATLAB program to verify your answer and plot the magnetic field in the  $x$ - $y$  plane in the region  $-0.5 \text{ m} \leq x \leq 0.5 \text{ m}$  and  $-0.5 \text{ m} \leq z \leq 0.5 \text{ m}$ .

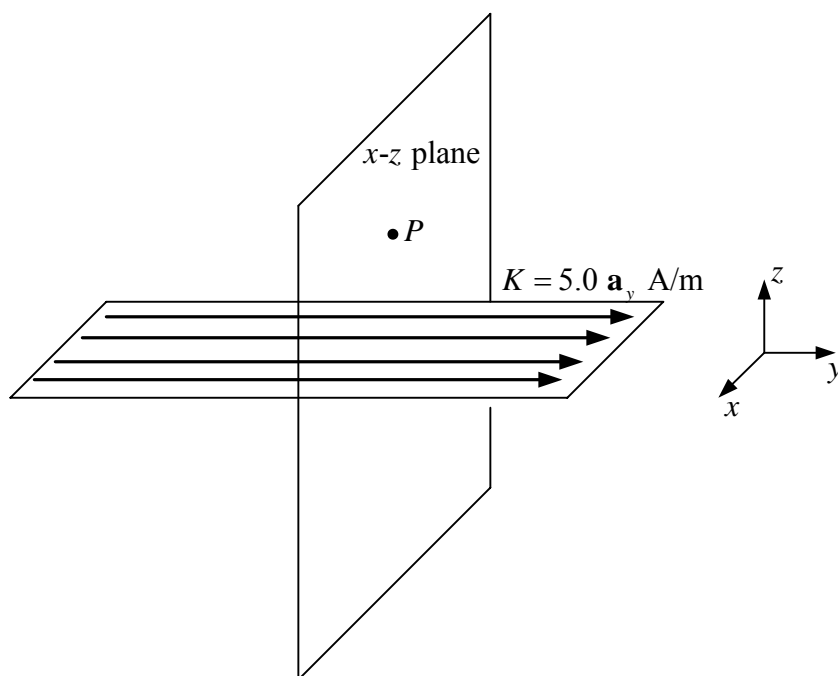


Figure 15.1 The example of Set 15.

**Analytical solution:**

As shown in Figure 15.2, since  $d\mathbf{L} = \mathbf{K}dS$ , the magnetic field resulting from a surface element

$$d\mathbf{H}_p = \frac{d\mathbf{L} \times \mathbf{R}}{4\pi R^3} = \frac{\mathbf{K} \times \mathbf{R}dS}{4\pi R^3}, \text{ where } \mathbf{R} \text{ is a vector pointing from the surface element to the observation point,}$$

$$\mathbf{R} = \overrightarrow{OP} - \overrightarrow{OC} = 0.25 \mathbf{a}_z - (x \mathbf{a}_x + y \mathbf{a}_y) = -x \mathbf{a}_x - y \mathbf{a}_y + 0.25 \mathbf{a}_z.$$

The cross product of  $\mathbf{K}$  and  $\mathbf{R}$  is given by

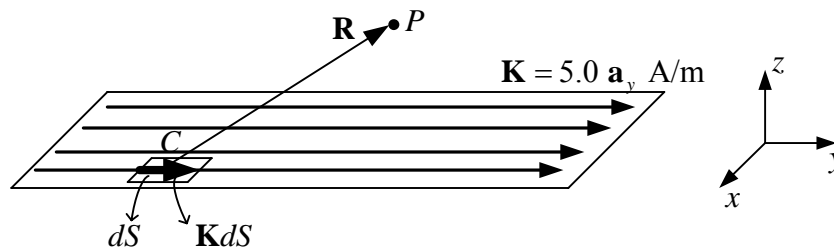
$$\mathbf{K} \times \mathbf{R} = \begin{vmatrix} \mathbf{a}_x & \mathbf{a}_y & \mathbf{a}_z \\ 0 & 5 & 0 \\ -x & -y & 0.25 \end{vmatrix} = \mathbf{a}_x \begin{vmatrix} 5 & 0 \\ -y & 0.25 \end{vmatrix} - \mathbf{a}_y \begin{vmatrix} 0 & 0 \\ -x & 0.25 \end{vmatrix} + \mathbf{a}_z \begin{vmatrix} 0 & 5 \\ -x & -y \end{vmatrix} = 1.25\mathbf{a}_x + 5x\mathbf{a}_z, \text{ therefore,}$$

$$d\mathbf{H}_p = \frac{(1.25 \mathbf{a}_x + 5x \mathbf{a}_z) dxdy}{4\pi \left(x^2 + y^2 + \frac{1}{16}\right)^{3/2}}, \text{ and the magnetic field resulting from the current sheet is}$$

$$\begin{aligned} \mathbf{H}_p &= \int_S d\mathbf{H}_p = \int_{x=-0.15}^{x=0.15} \int_{y=-\infty}^{y=\infty} \frac{1.25 \mathbf{a}_x + 5x \mathbf{a}_z}{4\pi \left(x^2 + y^2 + \frac{1}{16}\right)^{3/2}} dxdy \\ &= \int_{x=-0.15}^{x=0.15} \int_{y=-\infty}^{y=\infty} \frac{1.25 \mathbf{a}_x}{4\pi \left(x^2 + y^2 + \frac{1}{16}\right)^{3/2}} dxdy + \int_{x=-0.15}^{x=0.15} \int_{y=-\infty}^{y=\infty} \frac{5x \mathbf{a}_z}{4\pi \left(x^2 + y^2 + \frac{1}{16}\right)^{3/2}} dxdy \end{aligned}$$

We note that the  $z$  component is anti-symmetric in  $x$  about the origin (odd parity). Since the limits are symmetric, the integral of the  $z$  component over  $y$  is zero. We are left with

$$\begin{aligned} \mathbf{H}_p &= \int_{x=-0.15}^{x=0.15} \int_{y=-\infty}^{y=\infty} \frac{1.25\mathbf{a}_x}{4\pi \left(x^2 + y^2 + \frac{1}{16}\right)^{3/2}} dxdy = \frac{1.25}{4\pi} \mathbf{a}_x \int_{x=-0.15}^{x=0.15} \frac{y}{\left(x^2 + \frac{1}{16}\right) \sqrt{x^2 + y^2 + \frac{1}{16}}} \Bigg|_{y=-\infty}^{y=\infty} dx \\ &= \frac{1.25}{4\pi} \mathbf{a}_x \int_{x=-0.15}^{x=0.15} \left( \frac{1}{\left(x^2 + \frac{1}{16}\right) \sqrt{x^2 + 1 + \frac{1}{16y^2}}} \Bigg|_{y=\infty} - \frac{-1}{\left(x^2 + \frac{1}{16}\right) \sqrt{x^2 + 1 + \frac{1}{16y^2}}} \Bigg|_{y=-\infty} \right) dx \\ &= \frac{1.25}{4\pi} \mathbf{a}_x \int_{x=-0.15}^{x=0.15} \frac{2}{x^2 + \frac{1}{16}} dx = \frac{2.5}{\pi} \mathbf{a}_x \tan^{-1}(4x) \Big|_{x=-0.15}^{x=0.15} = \frac{2.5}{\pi} \times 1.0808 \mathbf{a}_x = 0.8601 \mathbf{a}_x \text{ A/m} \end{aligned}$$



**Figure 15.2** The vector  $\mathbf{R}$  pointing from the surface element to the observation point. The magnetic field resulting from the surface element is  $d\mathbf{H}_p = \frac{\mathbf{K} \times \mathbf{R} dS}{4\pi R^3}$ .

#### MATLAB solution:

We can calculate the magnetic field at a point  $P$  by calculating the magnetic field resulting from each surface element and adding all these elementary magnetic fields together. This can be formulated in the mathematical form  $\mathbf{H}_p = \sum_{i=1}^{i=n} \sum_{j=1}^{j=m} \frac{\mathbf{K} \times \mathbf{R}_{i,j} \Delta S}{4\pi R_{i,j}^3}$ . To plot the magnetic field on the  $x$ - $z$  plane, we need to build an array of the plotting plane and calculate  $\mathbf{H}$  of each plotting point. We use the function `quiver` to plot our vector plot.

#### MATLAB code:

```

clc; %clear the command window
clear; %clear all variables
d=0.30; %the width of the sheet in the x direction
L=20; %length of sheet in the y direction
J=5; %value of surface current density
Js=J*[0 1 0]; %the vector of surface current density
Xmin=-0.15; %coordinate of lowest x value on sheet
Xmax=0.15; %coordinate of maximum x value on sheet
Ymin=-10; %coordinate of lowest y value on sheet
Ymax=10; %coordinate of maximum y value on sheet
NumberOfXDivisions=20; %number of cells in the x direction
NumberOfYDivisions=100; %number of cells in the y direction
dx=(Xmax-Xmin)/NumberOfXDivisions; %step in the x direction
dy=(Ymax-Ymin)/NumberOfYDivisions; %step in the y direction
ds=dx*dy; %area of one subsection of sheet
ZCellCenter=0; %all points on sheet has a coordinate z=0
NumberOfXPlottingPoints=10; %number of plotting points along the x axis
NumberOfZPlottingPoints=10; %number of plotting points along the z axis
PlotXmin=-0.5; %lowest x value on the plot plane
PlotXmax=0.5; %maximum x value on the plot plane

```

## MATLAB Examples and Exercises (Set 15)

```

PlotZmin=-0.5; %lowest z value on the plot plane
PlotZmax=0.5; %maximum z value on the plot plane
PlotStepX=(PlotXmax-PlotXmin)/(NumberOfXPlottingPoints-1);%plotting step in the x direction
PlotStepZ=(PlotZmax-PlotZmin)/(NumberOfZPlottingPoints-1); %plotting step in the z direction
[XData,ZData]=meshgrid(PlotXmin:PlotStepX:PlotXmax, PlotZmin:PlotStepZ:PlotZmax); %build arrays of plot plane
PlotY=0; %all points on observation plane have zero y coordinate
Bx=zeros(NumberOfXPlottingPoints,NumberOfZPlottingPoints); %x component of field
Bz=zeros(NumberOfXPlottingPoints, NumberOfZPlottingPoints);%z component of field
for m=1:NumberOfXPlottingPoints %repeat for all plot points in the x direction
    for n=1:NumberOfZPlottingPoints %repeat for all plot points in the y direction
        PlotX=XData(m,n); %x coordinate of current plot point
        PlotZ=ZData(m,n); %z coordinate of current plot point
        if ((PlotZ==0)&(PlotX>=Xmin)&(PlotX<=Xmax)) % if the plotting point is on the current sheet
            Bx(m,n)=0.5*J;          % we use the model of infinite current sheet
            Bz(m,n)=0;
            continue;
        end
        Rp=[PlotX PlotY PlotZ]; %poistion vector of observation points
        for i=1:NumberOfXDivisions %repeat for all divisions in the x direction
            for j=1:NumberOfYDivisions %repeat for all cells in the y direction
                XCellCenter=Xmin+(i-1)*dx+0.5*dx; %X center of current subsection
                YCellCenter=Ymin+(j-1)*dy+0.5*dy; %Y center current subsection
                Rc=[XCellCenter YCellCenter ZCellCenter]; %position vector of center of current subsection
                R=Rp-Rc; %vector pointing from current subsection to the current observation point
                norm_R=norm(R); %get the distance between the current surface element and the observation point
                R_Hat=R/norm_R; %unit vector in the direction of R
                dH=(ds/(4*pi*norm_R*norm_R))*cross(Js,R_Hat); %this is the contribution from current element
                Bx(m,n)=Bx(m,n)+dH(1,1); %increment the x component at the current observation point
                Bz(m,n)=Bz(m,n)+dH(1,3); %increment the z component at the current observation point
            end %end of j loop
        end %end of i loop
    end %end of n loop
end % end of m loop

```

```

quiver(XData, ZData, Bx, Bz);
xlabel('x(m)');%label x axis
ylabel('z(m)');%label y axis
%The following routing caculates the magnetic field at point P
P=[0 0 0.25];%position of point P
Hp=[0 0 0];%the magnetic field at point P
for i=1:NumberOfXDivisions %repeat for all divisions in the x direction
    for j=1:NumberOfYDivisions %repeat for all cells in the y direction
        XCellCenter=Xmin+(i-1)*dx+0.5*dx; %X center of current subsection
        YCellCenter=Ymin+(j-1)*dy+0.5*dy; %Y center current subsection
        Rc=[XCellCenter YCellCenter ZCellCenter]; %position vector of center of current subsection
        R=P-Rc; %vector pointing from current subsection to the current observation point
        norm_R=norm(R); %get the distance between the current surface element and the observation point
        R_Hat=R/norm_R; %unit vector in the direction of R
        dH=(ds/(4*pi*norm_R*norm_R))*cross(Js,R_Hat); %this is the contribution from current element
        Hp=Hp+dH;
    end %end of j loop
end %end of i loop

```

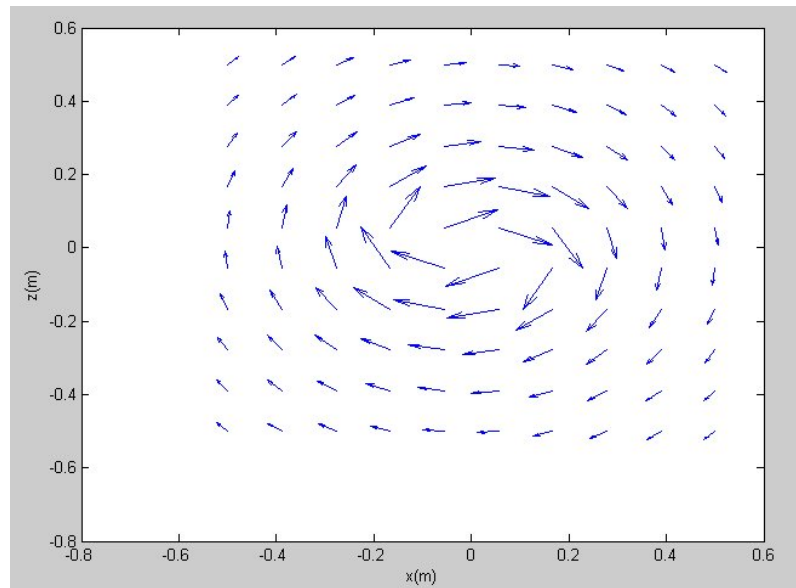
**Running result:**

```

>> Hp
Hp =
    0.8582    0    0.0000
>>

```

We can see that our MATLAB solution has a good agreement with our analytical solution.



**Figure 15.3** The MATLAB vector plot of the magnetic field in the  $x$ - $z$  plane caused by a current sheet flowing in the  $x$ - $y$  plane.

**Exercise:** A filament on the  $z$  axis lies in the region  $0 \leq z \leq 10.0$  m. Calculate  $H$  at  $P(0,1.0,0)$ . Write a MATLAB program to verify your answer and plot the magnetic field in the  $x$ - $y$  plane in the region  $-5.0 \text{ m} \leq x \leq 5.0 \text{ m}$  and  $-5.0 \text{ m} \leq y \leq 5.0 \text{ m}$ .

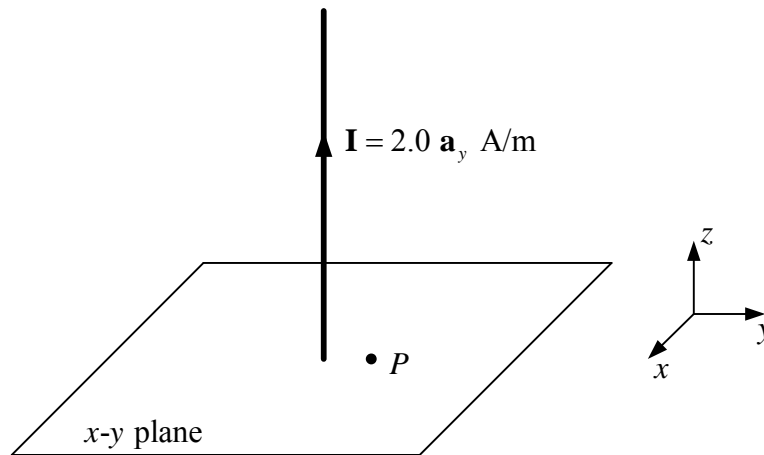


Figure 15.4 The exercise of Set 15.

## ECE2FH3 Electromagnetics I

Term II, January – April 2012

### MATLAB Examples and Exercises (Set 16)

Prepared by: Dr. M. H. Bakr and C. He

**Example:** A solenoid of radius 0.1 m whose axis is the  $z$  axis carries a current of 3 Amps. The solenoid is assumed to extend along the  $z$  axis from  $z = -0.5$  m to  $z = 0.5$  m. Write a MATLAB program that plots the magnetic field in the  $x$ - $z$  plane.

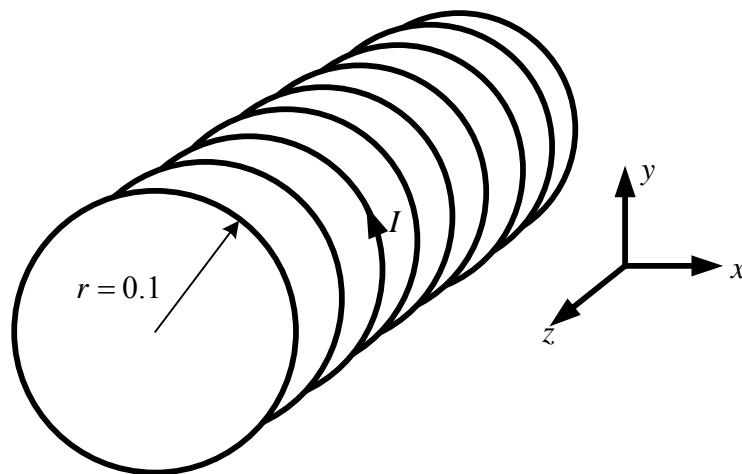


Figure 16.1 The example of Set 16.

**Analytical Part:**

We can assign a unique angle value to each point on the winding. For instance, if a point has a  $\phi$  angle of  $\pi/3$ , and it is on the third turn, then the parametric angle value we assign to this point is  $\phi' = \pi/3 + 2\pi \times (3-1) = 13\pi/3$ . In general,  $\phi' = \phi + 2(k-1)\pi$ , where  $1 \leq k \leq \text{number of turns}$  and  $0 \leq \phi < 2\pi$ . Knowing the value of  $\phi'$ , we can find the rectangular coordinate of a point:

$$x = r \cos \phi = r \cos[\phi + 2(k-1)\pi] = r \cos \phi' \quad (1)$$

$$y = r \sin \phi = r \sin[\phi + 2(k-1)\pi] = r \sin \phi' \quad (2)$$

Also, since the  $z$  coordinate is linearly increasing along the windings, we have

$$z(\phi') = z_{\min} + \frac{z_{\max} - z_{\min}}{(\phi'_{\max} - \phi'_{\min})} (\phi' - \phi'_{\min}) \quad (3)$$

Now we want to divide the winding into  $n$  segments along the direction of the current  $I$  in order to allow MATLAB program to calculate the magnetic field (see Figure 16.2). We then pick up  $n+1$  points on the winding. For the  $i$ th point, the angle is given by

$$\phi'_i = \phi'_{\min} + \frac{\phi'_{\max} - \phi'_{\min}}{n} (i-1).$$

By plugging this equation into (1), (2) and (3), we can find  $x_i$ ,  $y_i$ , and  $z_i$ . Also, we can find  $x_{i+1}$ ,  $y_{i+1}$ , and  $z_{i+1}$  in the same way. Note the  $i$ th segment is a vector given by

$$\Delta \mathbf{L}_i = (x_{i+1} - x_i) \mathbf{a}_x + (y_{i+1} - y_i) \mathbf{a}_y + (z_{i+1} - z_i) \mathbf{a}_z$$

and the vector  $\mathbf{R}_i$  (pointing from the center of the  $i$ th segment to the observation point) is given by (See Figure 16.2)

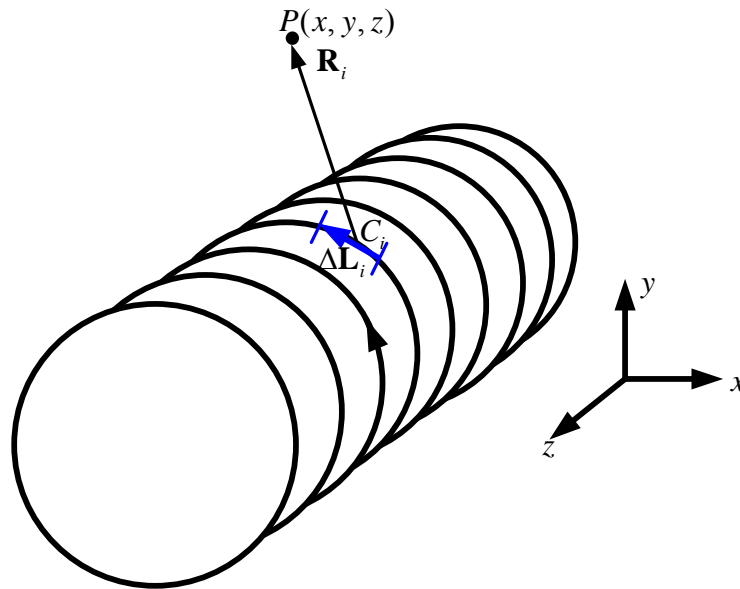
$$\mathbf{R}_i = P - C_i = (x, y, z) - \left( \frac{x_{i+1} + x_i}{2}, \frac{y_{i+1} + y_i}{2}, \frac{z_{i+1} + z_i}{2} \right)$$

Finally we can calculate the magnetic field at point P using the superposition formula:

$$\mathbf{H} = \sum_{i=1}^n \frac{I \Delta \mathbf{L}_i \times \mathbf{R}_i}{4\pi |\mathbf{R}_i|^3}.$$

The problem requires us to plot the magnetic field in the  $x$ - $z$  plane. We should thus calculate the magnetic field at a grid of points on the  $x$ - $z$  plane, and store the values in to a two-dimensional matrix.





**Figure 16.2**  $\Delta L_i$  is the  $i$ th segment along the winding and  $\mathbf{R}_i$  is the vector pointing from the center of  $i$ th segment to the observation point  $P$ .

**MATLAB code:**

```
clc; %clear the command window
```

```
clear; %clear all variables
```

```
NumberOfTurns=20; %Number of turns of the solenoid
```

```
Radius=0.1; %radius of solenoid
```

```
Zmin=-0.5; %coordinate of the lowest point on the solenoid
```

```
Zmax=0.5; %coordinate of the highest point on the solenoid
```

```
t_min=0; %lowest value of the curve parameter t
```

```
t_max=NumberOfTurns*2.0*pi; % for every turn we have an angle increment of 2*pi
```

```
NumberOfSegments=100; %we divide the solenoid into this number of segments
```

```
t_values=linspace(t_min,t_max, (NumberOfSegments+1)); %these are the values of the parameter t
```

```
x_values=Radius*cos(t_values);
```

```
y_values=Radius*sin(t_values);
```

```
z_values=Zmin+((Zmax-Zmin)/(t_max-t_min))*(t_values-t_min);
```

```
I=3; %value of surface current density
```

## MATLAB Examples and Exercises (Set 16)

```

NumberOfXPlottingPoints=20; %number of plotting points along the x axis
NumberOfZPlottingPoints=20; %number of plotting points along the z axis
PlotXmin=-0.5; %lowest x value on the plot plane
PlotXmax=0.5; %maximum x value on the plot plane
PlotZmin=-1; %lowest z value on the plot plane
PlotZmax=1; %maximum z value on the plot plane
PlotStepX=(PlotXmax-PlotXmin)/(NumberOfXPlottingPoints-1);%plotting step in the x direction
PlotStepZ=(PlotZmax-PlotZmin)/(NumberOfZPlottingPoints-1); %plotting step in the z direction
[XData,ZData]=meshgrid(PlotXmin:PlotStepX:PlotXmax, PlotZmin:PlotStepZ:PlotZmax); %build arrays of plot plane
PlotY=0; %all points on observation plane have zero y coordinate
Bx=zeros(NumberOfXPlottingPoints,NumberOfZPlottingPoints); %x component of field
Bz=zeros(NumberOfXPlottingPoints, NumberOfZPlottingPoints);%z component of field
for m=1:NumberOfXPlottingPoints %repeat for all plot points in the x direction
    for n=1:NumberOfZPlottingPoints %repeat for all plot points in the z direction
        PlotX=XData(m,n); %x coordinate of current plot point
        PlotZ=ZData(m,n); %z coordinate of current plot point
        Rp=[PlotX PlotY PlotZ]; %position vector of observation points
        for i=1:NumberOfSegments %repeat for all line segments of the solenoid
            XStart=x_values(i,1); %x coordinate of the start of the current line segment
            XEnd=x_values(i+1,1); %x coordinate of the end of the current line segment
            YStart=y_values(i,1); %y coordinate of the start of the current line segment
            YEnd=y_values(i+1,1); %y coordinate of the end of the current line segment
            ZStart=z_values(i,1); %z coordinate of the start of the current line segment
            ZEnd=z_values(i+1,1); %z coordinate of the end of the current line segment
            dl=[(XEnd-XStart) (YEnd-YStart) (ZEnd-ZStart)]; %the vector of differential length
            Rc=0.5*[(XStart+XEnd) (YStart+YEnd) (ZStart+ZEnd)];%position vector of center of segment
            R=Rp-Rc; %vector pointing from current subsection to the current observation point
            norm_R=norm(R); %get the distance between the current surface element and the observation point
            R_Hat=R/norm_R; %unit vector in the direction of R
            dH=(I/(4*pi*norm_R*norm_R))*cross(dl,R_Hat); %this is the contribution from current element
            Bx(m,n)=Bx(m,n)+dH(1,1); %increment the x component at the current observation point
            Bz(m,n)=Bz(m,n)+dH(1,3); %increment the z component at the current observation point
        end %end of i loop
    end %end of n loop
end % end of m loop
quiver(XData, ZData, Bx, Bz);

```

```
xlabel('x(m)');%label x axis
ylabel('z(m)');%label z axis
```

Running result:

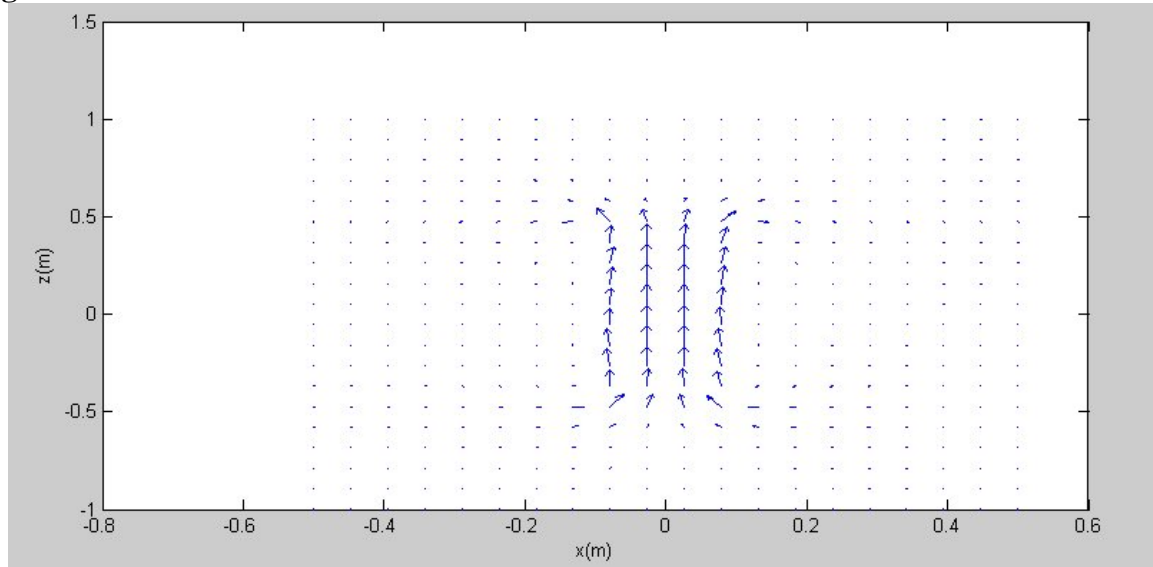


Figure 16.3 The magnetic field lines generated by a solenoid centered along the z axis.

**Exercise:** A toroid whose axis is the z axis carries a current of 5.0 A and has 200 turns. The inner radius is 1.5 cm while the outer radius is 2.5 cm. Write a MATLAB program that computes and plots the magnetic field in the x-y plane in the region  $-4.0 \text{ cm} \leq x \leq 4.0 \text{ cm}$  and  $-4.0 \text{ cm} \leq y \leq 4.0 \text{ cm}$ .

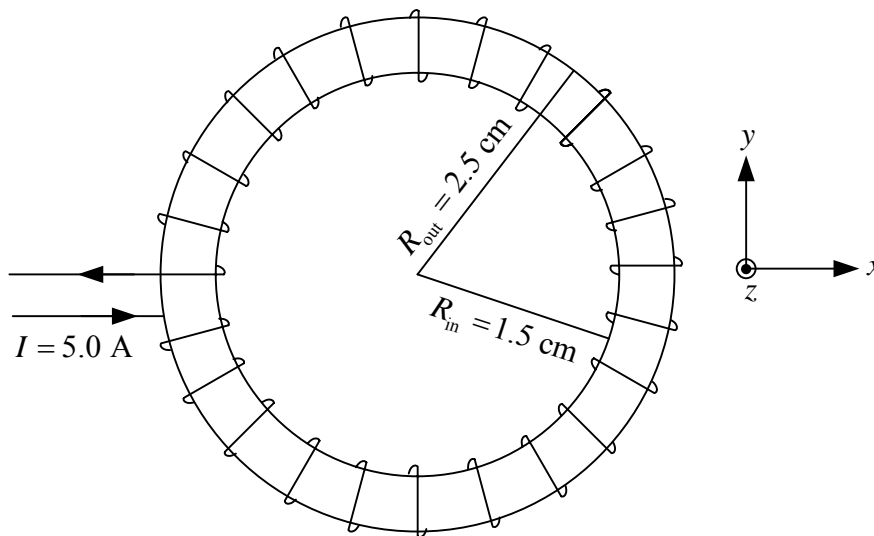


Figure 16.4 The exercise of Set 16.

**ECE2FH3****Electromagnetics I**

Term II, January – April 2012

**MATLAB Examples and Exercises (Set 17)**

Prepared by: Dr. M. H. Bakr and C. He

**Example:** A rectangular coil is composed of 1 turn of a filamentary conductor. Find the mutual inductance in free space between this coil and an infinite straight filament on the  $z$  axis if the four corners of the coil are located at:  $(1, 1, 0)$ ,  $(1, 3, 0)$ ,  $(1, 3, 1)$ , and  $(1, 1, 1)$ . Write a MATLAB program to verify your answer.

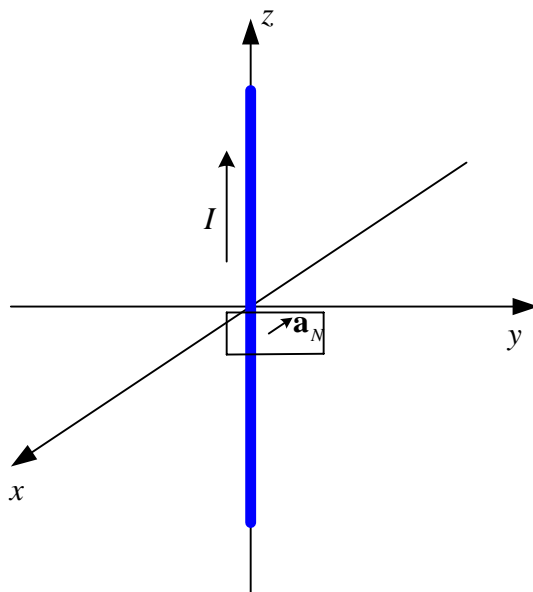


Figure 17.1 The example of Set 17.

**Analytical solution:**

As shown in Figure 17.2, if we assume that the filament current is in the  $+\mathbf{a}_z$  direction, the  $\mathbf{B}$  field of the filament penetrates the coil in the  $+\mathbf{a}_\phi$  direction and the direction normal to the loop plane is  $-\mathbf{a}_x$ . The  $\mathbf{B}$  field resulting from an infinite filamentary conductor taking a current  $I$  is given by

$$\mathbf{B} = \frac{\mu_0 I}{2\pi\rho} \mathbf{a}_\phi$$

The flux through the coil is now

$$\Phi = \int_S \mathbf{B} \cdot d\mathbf{S} = \int_{z=0}^{z=1} \int_{y=1}^{y=3} \left( \frac{\mu_0 I}{2\pi\rho} \mathbf{a}_\phi \right) \cdot (-\mathbf{a}_x dydz) = \int_{z=0}^{z=1} \int_{y=1}^{y=3} \frac{\mu_0 I dydz}{2\pi\rho} (\mathbf{a}_\phi) \cdot (-\mathbf{a}_x)$$

where

$$\mathbf{a}_\phi = -\mathbf{a}_x \sin \phi + \mathbf{a}_y \cos \phi$$

therefore

$$\mathbf{a}_\phi \cdot (-\mathbf{a}_x) = \sin \phi = \frac{y}{\rho} = \frac{y}{\sqrt{y^2 + 1}}$$

Now, the flux through the coil is

$$\Phi = \int_{z=0}^{z=1} \int_{y=1}^{y=3} \frac{\mu_0 I y}{2\pi\rho^2} dydz = \int_{y=1}^{y=3} \frac{\mu_0 I y}{2\pi\rho^2} dy = \frac{\mu_0 I}{4\pi} \ln(y^2 + 1) \Big|_{y=1}^{y=3} = (1.6 \times 10^{-7}) I$$

The mutual inductance is then

$$M = \frac{N\Phi}{I} = \frac{1 \times 1.6 \times 10^{-7} I}{I} = 1.6 \times 10^{-7} \text{ H}$$

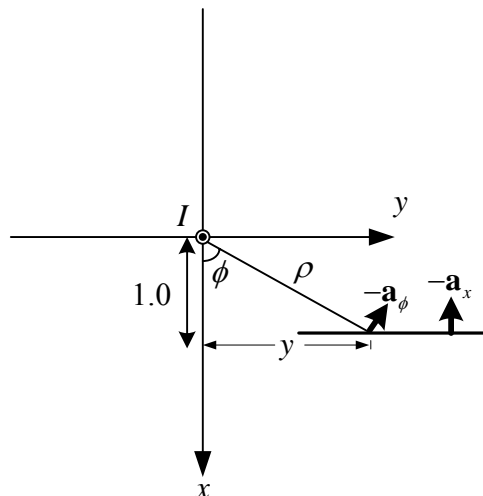


Figure 17.2  $\rho$  is the distance from the straight filament to the observation point, the current is in the  $\mathbf{a}_z$  direction and by right hand rule the direction normal to the coil is  $-\mathbf{a}_x$ .

**MATLAB solution:**

In the MATLAB program, we replace the infinite straight filament by a sufficiently long filament. Then we evaluate the magnetic field resulting from this filament at each surface element inside the coil. The dot product of a surface element and its magnetic field gives the flux through the surface element. By adding the flux through each surface element we obtain the flux through the area inside the coil. The mutual inductance is then obtained by dividing out the current  $I$ .

**MATLAB code:**

```

clc; %clear the command window
clear; %clear all variables
mu=4*pi*1e-7;
I=1.0;%current of the filament
end1=[0 0 -30];%end of the filament
end2=[0 0 30];%end of the filament
Number_of_Segments=250;%number of increasing steps along the filament
dL=(end2-end1)/Number_of_Segments;%vector increment along the filament
aN=[-1 0 0];% direction normal to the surface of the coil
NumberOfYSteps=20;%number of increasing steps of the coil area along the y direction
NumberOfZSteps=20;%number of increasing steps of the coil area along the z direction
ymin=1;%lowest y corodinate of the coil
ymax=3;%maxium y corodinate of the coil
zmin=0;%lowest z corodinate of the coil
zmax=1;%maxium z corodinate of the coil
dy=(ymax-ymin)/NumberOfYSteps;% area increment along the y direction
dz=(zmax-zmin)/NumberOfZSteps;% area increment along the z direction
flux=0;%flux through the coil
dS=dy*dz;%increament area
xp=1.0;%x coordinate is always 1.0 on the coil
for m=1:NumberOfZSteps %repeat for all points in the z direction
    for n=1:NumberOfYSteps %repeat for all points in the y direction
        yp=ymin+0.5*dy+(n-1)*dy;%y coordinate of current surface element
        zp=zmin+0.5*dz+(m-1)*dz;%z coordinate of current surface element
        Rp=[xp yp zp];%the position of current surface element
        B=[0 0 0];%the magnetic field at current surface element
        for i=1:Number_of_Segments %repeat for all divisions in the z direction
            C=end1+(i-1)*dL+0.5*dL; %X center of current subsection
            R=Rp-C; %vector pointing from current subsection to the current observation point
            norm_R=norm(R); %get the distance between the current surface element and the observation point
            R_Hat=R/norm_R; %unit vector in the direction of R

```

```

dH=(I/(4*pi*norm_R*norm_R))*cross(dL,R_Hat); %this is the contribution from current element
B=B+mu*dH;
end %end of i loop
dflux=dS*dot(B,aN);%flux through current surface element
flux=flux+dflux;%get contribution to the total flux
end %end of n loop
end % end of m loop
M=flux/I;% the mutual inductance

```

**Running result:**

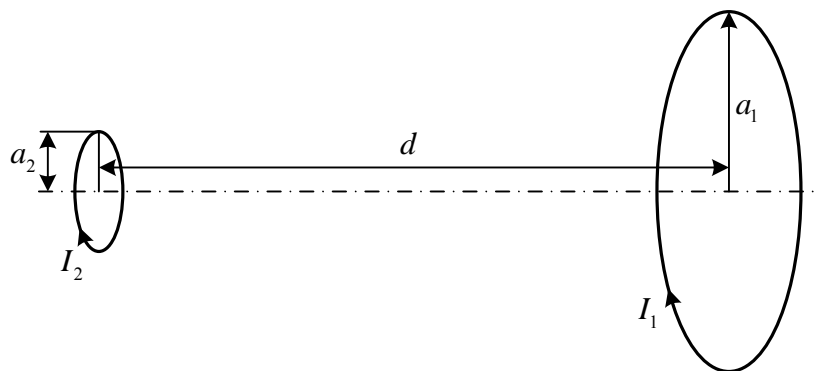
```

>> M
M =
1.6051e-007
>>

```

We see that our MATLAB solution has a good agreement with our analytical solution.

**Exercise:** Two coils with radii  $a_1$  and  $a_2$  are separated by a distance of  $d$  as shown in Figure 17.3. The dimensions are  $a_1 = 0.01$  m,  $a_2 = 0.04$  m, and  $d = 0.1$  m. Find the mutual inductance of the coils. Write a MATLAB program to verify your answer.



**Figure 17.3** The geometry of the exercise of Set 17.

## ECE2FH3

## Electromagnetics I

Term II, January – April 2012

## MATLAB Examples and Exercises (Set 18)

Prepared by: Dr. M. H. Bakr and C. He

**Example:** A solenoid of radius 0.05 m is centered along the  $z$  axis as shown in Figure 18.1. The solenoid is assumed to extend along the  $z$  axis from  $z = -0.25$  m to  $z = 0.25$  m. Find the inductance analytically if the solenoid has 100 turns and  $\mu_r = 1$ . Write a MATLAB program to evaluate the inductance again and compare your answers.

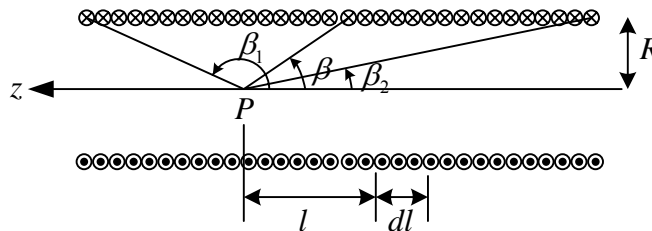


Figure 18.1 A cross section of the solenoid.

**Analytical solution:**

Assume the solenoid has a radius of  $R$ , takes a current of  $I$  and has  $n$  turns per unit length, as shown in Figure 18.1. We consider a very short segment  $dl$  of this solenoid. Then this short segment has a total number of  $ndl$  turns. Therefore, the magnetic field at a point  $P$  resulting from the short segment is

$$dB = \frac{\mu}{2} \frac{R^2 Indl}{(R^2 + l^2)^{3/2}}$$

where  $l$  is the distance from the observation point to the short segment, as shown in figure 18.1. Therefore, the magnetic field at point  $P$  resulting from the solenoid is

$$B = \int_L dB = \int_L \frac{\mu}{2} \frac{R^2 Indl}{(R^2 + l^2)^{3/2}}$$

However, as shown in Figure 18.1, we have  $l = R \cot \beta$ . It follows that

$$dl = -R \csc^2 \beta d\beta$$



and

$$R^2 + l^2 = R^2(1 + \cot^2 \beta) = R^2 \csc^2 \beta$$

Therefore, we have

$$B = \frac{\mu}{2} nI \int_{\beta=\beta_1}^{\beta=\beta_2} \frac{R^2 (-R \csc^2 \beta d\beta)}{R^3 \csc^3 \beta} = \frac{\mu}{2} nI \int_{\beta=\beta_1}^{\beta=\beta_2} (-\sin \beta) d\beta = \frac{\mu}{2} nI (\cos \beta_2 - \cos \beta_1)$$

For a sufficiently long solenoid the magnetic field inside the solenoid is approximately the same every where. We use the magnetic field in the center of the solenoid to evaluate the flux linkage. The magnetic field at the center of the solenoid is

$$B = \frac{\mu}{2} nI (\cos \beta_2 - \cos \beta_1) = \frac{\mu}{2} nI \left( \frac{0.25}{\sqrt{0.05^2 + 0.25^2}} - \frac{-0.25}{\sqrt{0.05^2 + 0.25^2}} \right) = \frac{1.9612}{2} \frac{\mu nI}{h}$$

and the flux linkage is

$$\lambda = N\Phi_{\text{tot}} = NBS = \frac{1.9612}{2} \frac{\mu N^2 I \pi a^2}{h}$$

Finally, we divide by the current to find the inductance

$$L = \frac{\lambda}{I} = \frac{1.9612}{2} \frac{\mu N^2 I \pi a^2}{h} = 1.9357 \times 10^{-4} \text{ H}$$

### MATLAB solution:

The inductance we derived analytically is an approximate value because we are assuming the solenoid is infinitely long and tightly wrapped. The magnetic field intensity is actually different for different points inside the solenoid, and the flux linkage to each turn of coil varies. Using a MATLAB program, we can calculate a more accurate  $\lambda$

$$\lambda = \Phi_1 + \Phi_2 + \dots + \Phi_i + \dots + \Phi_N = \sum_{i=1}^N \Phi_i$$

where  $\Phi_i$  is the flux linking the  $i$ th turn which is given by

$$\Phi_i = \sum_{n=1}^p \sum_{m=1}^q \mathbf{B}_{m,n} \cdot \Delta \mathbf{S}_{m,n}$$

where  $\Delta \mathbf{S}_{m,n}$  is the element surface of the cross-sectional area, and  $\mathbf{B}_{m,n}$  is the magnetic field intensity at  $\Delta \mathbf{S}_{m,n}$ . In set 16 we learned how to calculate  $\mathbf{B}_{m,n}$ . We utilize the formula  $\Phi_i = \sum_{n=1}^p \sum_{m=1}^q \mathbf{B}_{m,n} \cdot \Delta \mathbf{S}_{m,n}$  where

we use  $p$  steps in the  $\rho$  direction  $q$  steps in the  $\phi$  direction. We can further simplify the flux linking the  $i$ th loop by:

$$\Phi_i = q \sum_{n=1}^p \mathbf{B}_n \cdot \Delta \mathbf{S}_n$$

### MATLAB code:

```
clc; %clear the command window
clear; %clear all variables
mu=4*pi*1e-7;
```

```

NumberOfTurns=100; %Number of turns of the solenoid
Radius=0.05; %radius of solenoid
Zmin=-0.25; %coordinate of the lowest point on the solenoid
Zmax=0.25; %coordinate of the highest point on the solenoid
t_min=0; %lowest value of the curve parameter t
t_max=NumberOfTurns*2.0*pi; % for every turn we have an angle increment of 2*pi
NumberOfSegments=1000; %we divide the solenoid into this number of segments
t_values=linspace(t_min,t_max, (NumberOfSegments+1)); %these are the values of the parameter t
x_values=Radius*cos(t_values);%x coordinates of all selected point on the winding
y_values=Radius*sin(t_values);%y coordinates of all selected point on the winding
deltaZ=linspace(Zmin,Zmax,(NumberOfTurns));%z coordinates increases when turn increases
z_values=zeros(NumberOfSegments,1);
for k=1:NumberOfTurns
    z_values((1+(k-1)*10):k*10)=deltaZ(k);
end
I=1; %value of surface current density
aN=[0 0 1];%direction that normal to each turn
NumberOfRhoSteps=20;%the area increasing steps in the rho direction
NumberOfPhiSteps=20;%the area increasing steps in the phi direction
drho=Radius/NumberOfRhoSteps;%area increment along the direction of rho
dphi=2*pi/NumberOfPhiSteps;%area increment along the direction of phi
flux=0;
for m=1:NumberOfTurns
    for j=1: NumberOfRhoSteps
        rho=(j-1)*drho+0.5*drho; %rho of current surface element
        phi=0.5*dphi; %phi of current surface element
        dS=rho*drho*dphi;%area of current element
        xp=rho*cos(phi);%x coordinate of current surface element
        yp=rho*sin(phi);%y coordinate of current surface element
        zp=z_values(m,1);%z coordinate of current surface element
        Rp=[xp yp zp];%position of current surface element
        B=[0 0 0];
        for i=1:NumberOfSegments %repeat for all line segments of the solenoid
            XStart=x_values(i,1); %x coordinate of the start of the current line segment
            XEnd=x_values(i+1,1); %x coordinate of the end of the current line segment
            YStart=y_values(i,1); %y coordinate of the start of the current line segment
            YEnd=y_values(i+1,1); %y coordinate of the end of the current line segment
        end
    end
end

```

## MATLAB Examples and Exercises (Set 18)

```

ZStart=z_values(i,1); %z coordinate of the start of the current line segment
dl=[(XEnd-XStart) (YEnd-YStart) 0]; %the vector of differential length
Rc=0.5*[(XStart+XEnd) (YStart+YEnd) (2*ZStart)];%position vector of center of segment
R=Rp-Rc; %vector pointing from current subsection to the current observation point
norm_R=norm(R); %get the distance between the current surface element and the observation point
R_Hat=R/norm_R; %unit vector in the direction of R
dH=(I/(4*pi*norm_R*norm_R))*cross(dl,R_Hat); %this is the contribution from current element
B=B+mu*dH;%get contribution to the magnetic field at current surface element
end %end of i loop
dflux=dS*(dot(B,aN));%the magnetic flux through current surface element
flux=flux+dflux;%get contribution to the total flux linkage
end
end
numda=flux*NumberOfPhiSteps;%the flux linkage
L=numda/I;%inductance of solenoid

```

**Running result:**

```

>> L
L =
    1.3414e-004
>>

```

Comparing the analytical answer and the MATLAB answer we find a significant difference between them. The actual inductance value should be closer to the MATLAB answer. It makes sense that the analytical answer is larger because we used the strongest magnetic field inside the solenoid (at the center) to evaluate the flux linkages analytically. If we increase the number of turns of the solenoid and increase the ratio of  $h/R$ , the two answers will have a better agreement.

**Exercise:** A toroid whose axis is the  $z$  axis has 200 turns. The inner radius is 2.0 cm while the outer radius is 2.5 cm. Find the inductance analytically if the solenoid has 100 turns and  $\mu_r = 1$ . Write a MATLAB program to verify your answer.