



Faculty of Engineering and Technology
Electrical and Computer Engineering Department
Simulation Lab (4104)
Amplitude Modulation and demodulation in lab VIEW

Prepared by:

Name: Anas Tomaizeh

Number: 1152325

Instructor:

Teacher Assistance:

Eng. Ahmed W.Hamed

Dr: Jamal syam

Date:

29/4/2019

Section: #1

Abstract:

The aim of this experiment is to become familiar with new programme, which is Lab VIEW or virtual instrument, and to simulate AM modulation by this new tool and show the results when some parameter changed such as frequency, modulation index, amplitude and carrier frequency.

Results: The results obtain in this experiment are acceptable with theoretical theorems.

Table of Contents

1. Introduction:	4
2. Methods and materials:	5
2.1: Amplitude modulation and demodulation:	5
2.2: Calculator:.....	6
4. Procedure:	7
5. Results:	9
7. Conclusion:	11
8. References:	12

List of Figures:

Figure 1: block diagram of generation of AM modulation	4
Figure 2: Frequency representation of AM signal	4
Figure 3: Demodulation of AM signal	5
Figure 4: Implementation of AM modulation in lab View	5
Figure 5: Demodulation of AM signal implemented in lab View.....	6
Figure 6: Calculator system implemented in lab view	6
Figure 7: Simulate signal setting.....	7
Figure 8: Spectral Analyser setting	7
Figure 9: carrier, modulated and frequency representation of AM modulation.....	9
Figure 10: demodulated signal	9
Figure 11: multiplication operation and its results.....	10
Figure 12: Division operation and its result.....	10
Figure 13: addition operations and its result.....	10

1. Introduction:

Amplitude modulation (AM) is a modulation technique used in electronic communication, most commonly for transmitting information via a radio carrier wave. In amplitude modulation, the amplitude (signal strength) of the carrier wave is varied in proportion to that of the message signal being transmitted. The message signal is, for example, a function of the sound to be reproduced by a loudspeaker, or the light intensity of pixels of a television screen. This technique contrasts with frequency modulation, in which the frequency of the carrier signal is varied. The equations describe the AM modulated signal

$$s(t) = Ac(1 + kam(t)) \cos 2\pi fct \dots\dots(1)$$

Where: $m(t)$: message signal, ka : sensitivity of the modulator and f_c : carrier frequency.

And the block diagram describe the generat the AM modualtions shown in Figure 1:

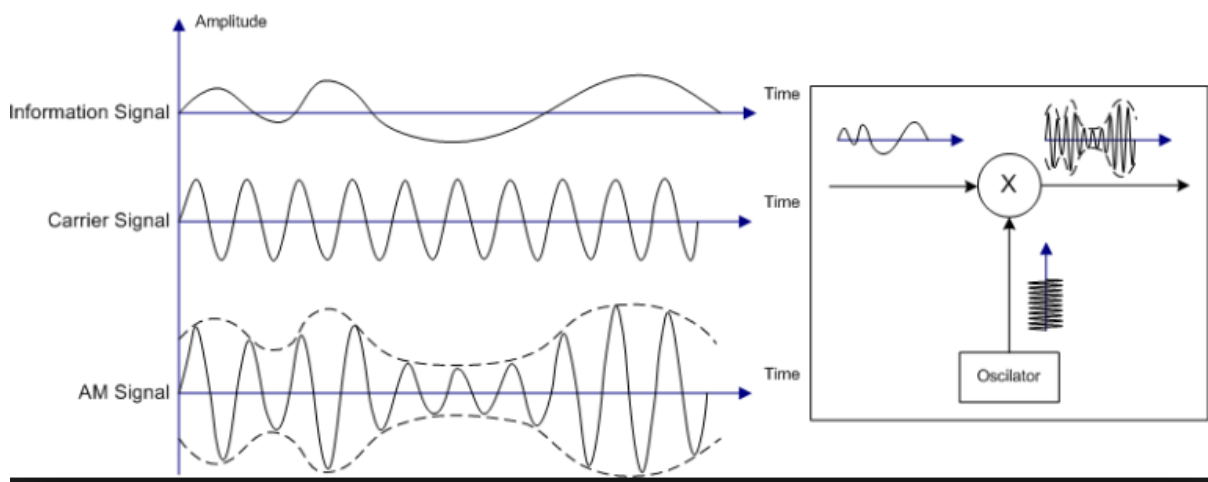

Figure 1: block diagram of generation of AM modulation

The frequency representation of AM signal shown in Figure 2:

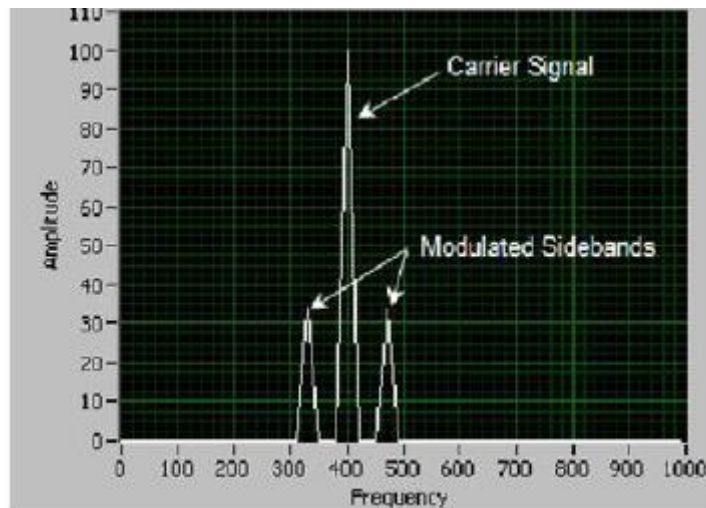

Figure 2: Frequency representation of AM signal

The demodulation process of AM signal: There are a number of techniques that can be used to demodulate AM signals. Different types are used in different applications to suit their performance and cost. Diode rectifier envelope detector: This form of detector is the simplest form, only requiring a single diode and a couple of other low cost components. The performance is adequate for low cost AM broadcast radios, but it does not meet the standards of other forms of demodulation. The block diagram describe the demodulation of AM signal shown in the Figure 3.

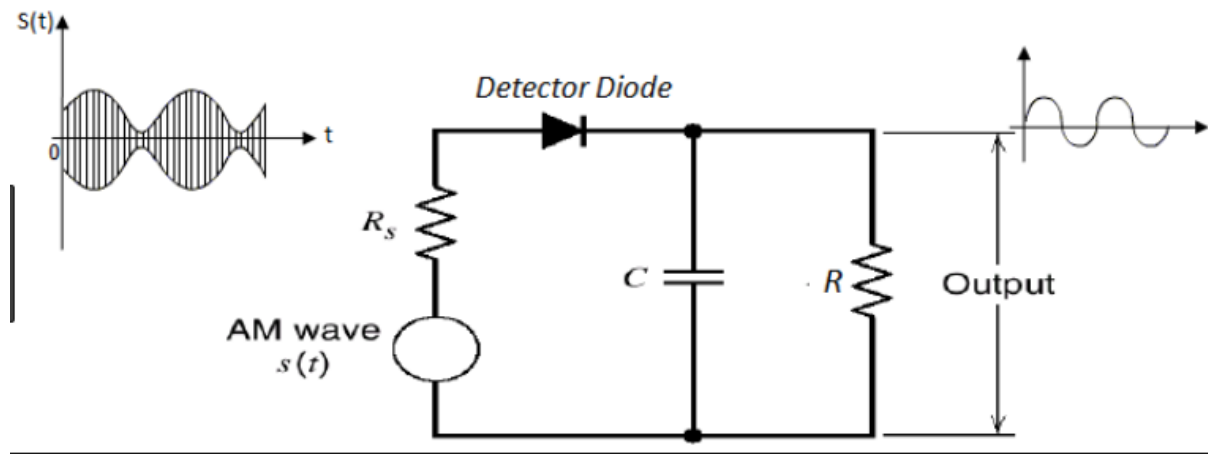

Figure 3: Demodulation of AM signal

2. Methods and materials:

2.1: Amplitude modulation and demodulation:

The block diagram, which is, represent the generation of AM signal was implemented in Lab View Program, it is show in the Figure 4, these blocks inserted from the library and wired inside while loop.

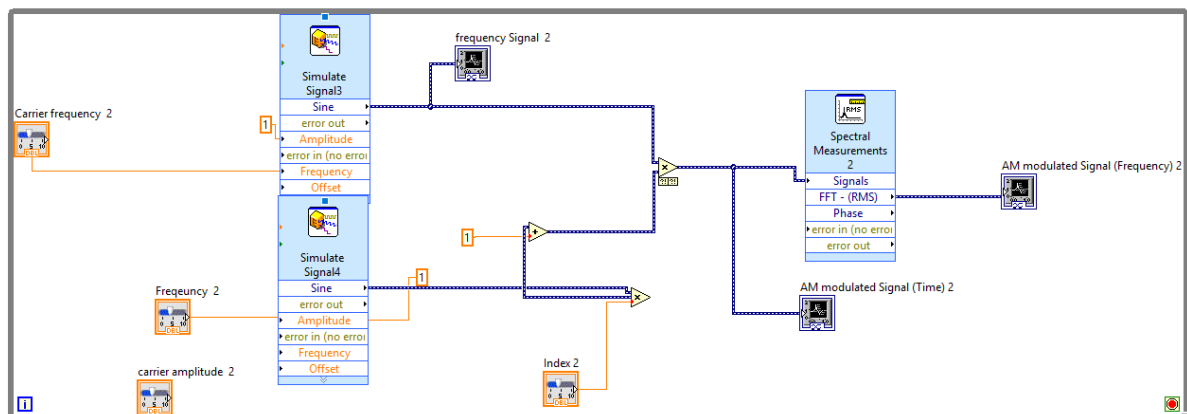

Figure 4: Implementation of AM modulation in lab View

There are different methods to demodulate the AM signal, the method used in this experiment contain from diode, DC removable and low pass Filter, the

Figure 5 show the demodulation of AM signal.

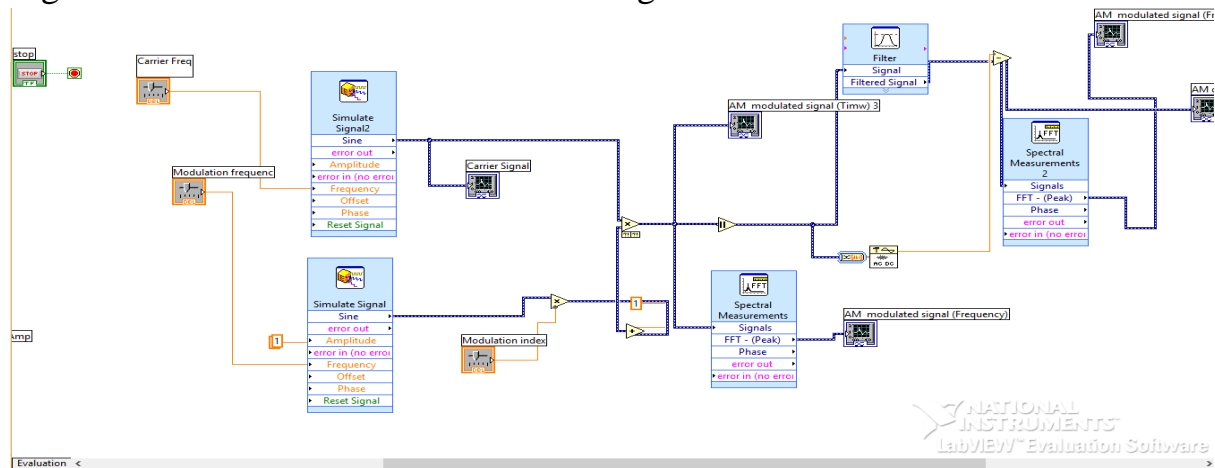

Figure 5: Demodulation of AM signal implemented in lab View

2.2: Calculator:

The system shown in the Figure 6 representation the calculator, this system implemented in lab View use two controls for two numbers, indicator to display the result of operation and a slide control to specify the operation to be performed.

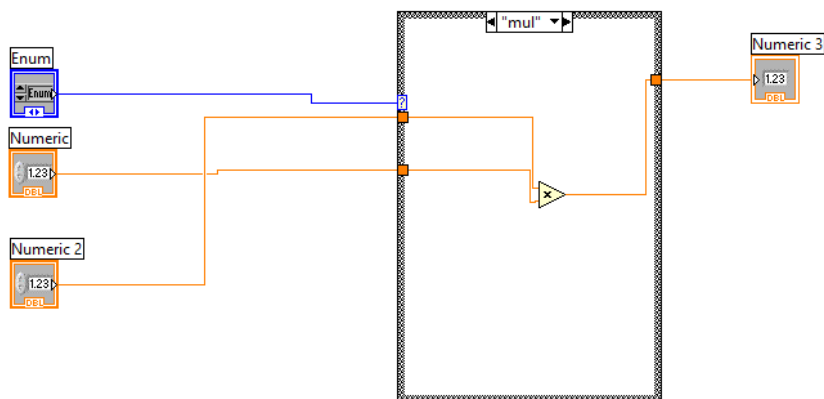

Figure 6: Calculator system implemented in lab view

4. Procedure:

The systems shown in the Figures 4 and 5 were built in lab View program, from the library of software the while loop inserted and it is make as a suitable size to add the component inside it.

In the front panel, the waveform and slides pointer were inserted in it from library, then simulate signal was inserted in the control window and the setting of this part was changed as shown in the figure 7

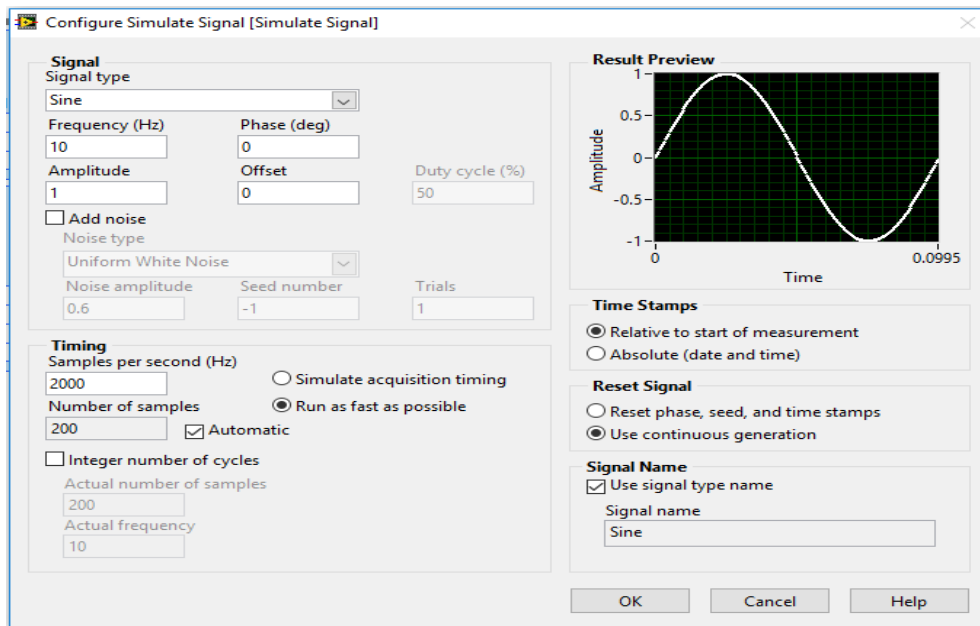

Figure 7: Simulate signal setting

On the same window the spectral analyser inserted from the library, and the setting of it changed as shown in the Figure 8

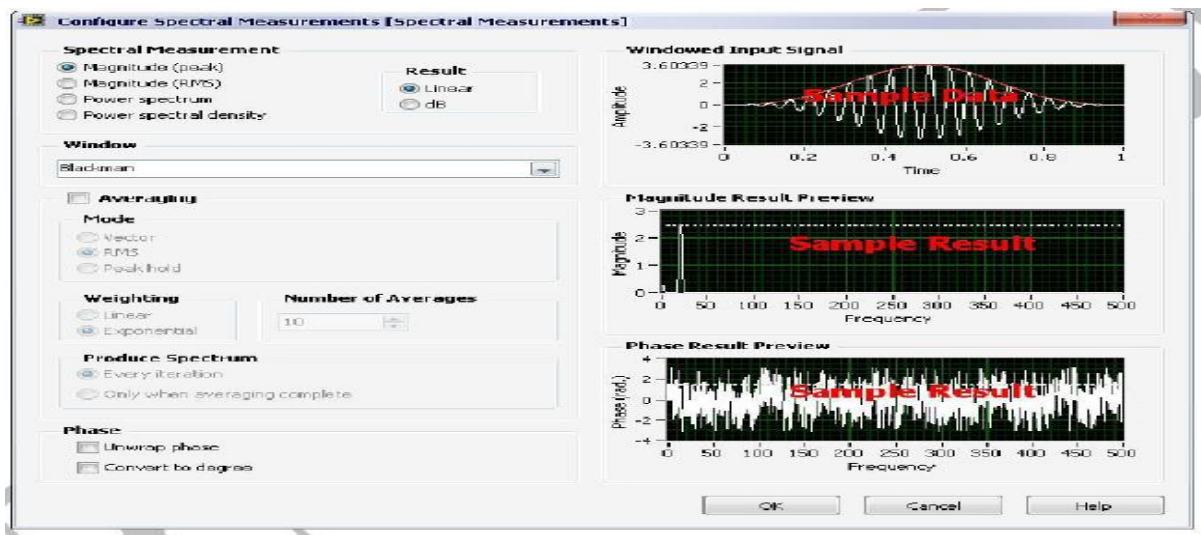

Figure 8: Spectral Analyser setting

Another components inserted in the control window such as: Multiply, adder there are obtained from numerical library, and it connected as show in the Figures.

For calculator, two controls for two numbers, indicator to display the result of operation add, and a slide control to specify the operation to be performed were all placed was inserted on the front panel.

5. Results:

The result from the system shown in the Figure 4 which is the generation of AM signal appear at front panel and it is show in the Figure

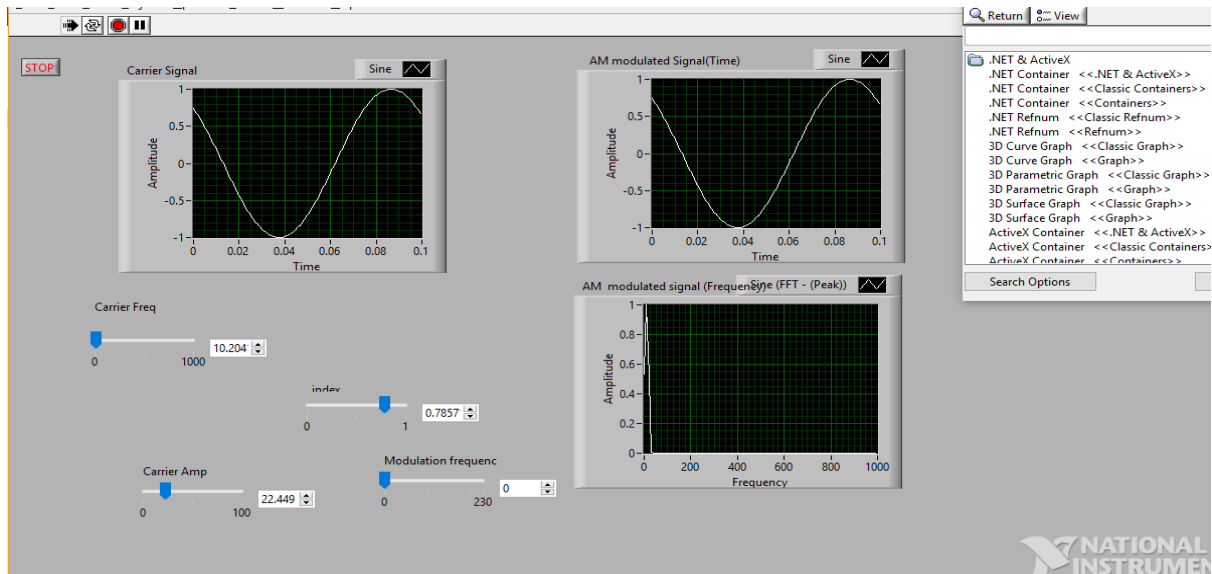

Figure 9: carrier, modulated and frequency representation of AM modulation

The result obtained from the figure 5, which is the demodulation of AM signal shown in the Figure

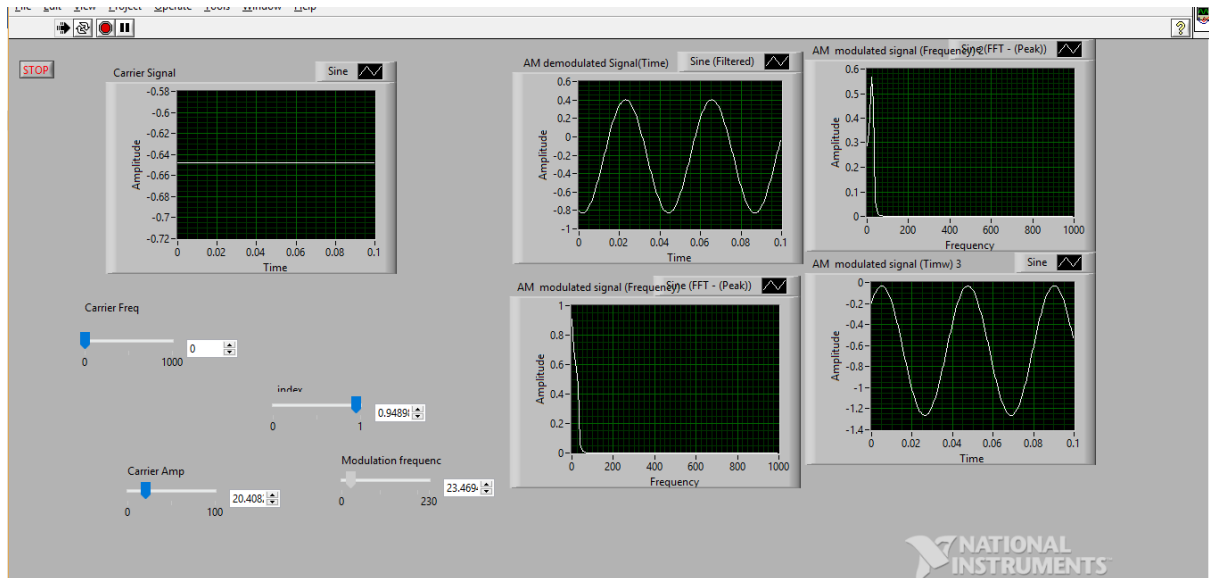

Figure 10: demodulated signal

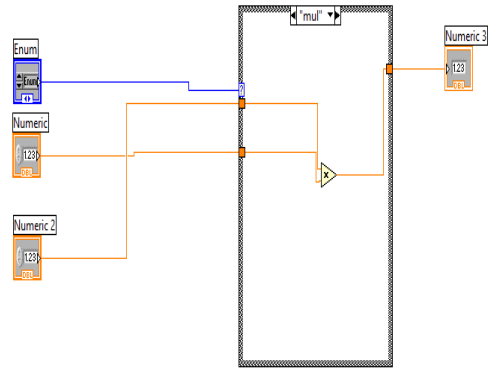
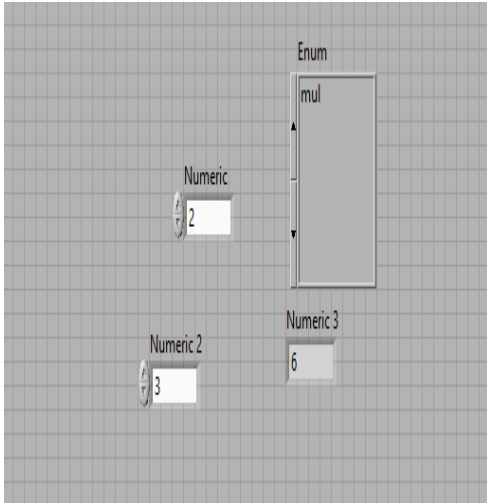

Figure 11: multiplication operation and its results

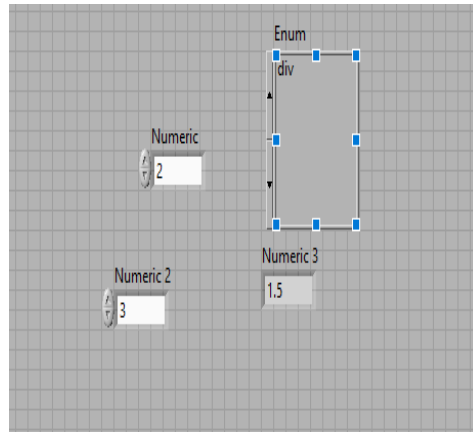
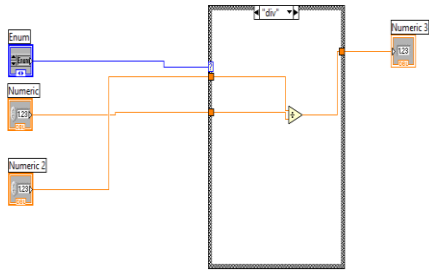

Figure 12: Division operation and its result

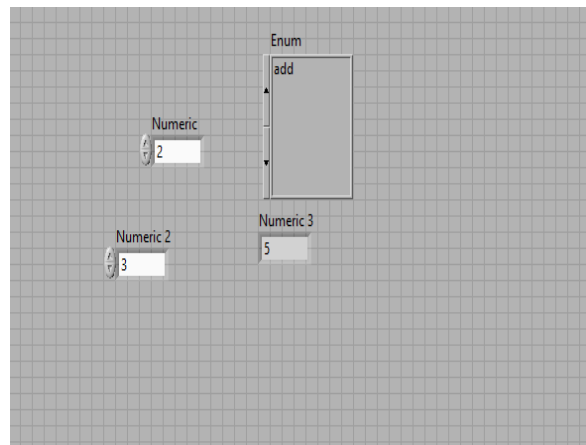
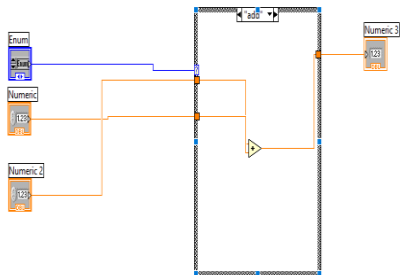

Figure 13: addition operations and its result

7. Conclusion:

In this experiment, AM Modulation, Demodulation and a calculator system implemented in LabVIEW Software, the main benefits of this experiment was to get familiar with the software and to see its ability to test the effect of parameter changing on the modulation and demodulation process.

8. References:

[1]https://www.google.ps/search?q=Am+modulation&safe=strict&source=lnms&tbm=isch&sa=X&ved=0ahUKEwjK1aOAqvPhAhXRZFAKHZqdA4EQ_AUIDigB&biw=1242&bih=553#imgdii=f-l8gq6okAE8wM:&imgsrc=XiQm_UI_P1kP_M:

[2] Simulation LAB manual, 2019-second semester editions April 29, 2019 4.38 AM