

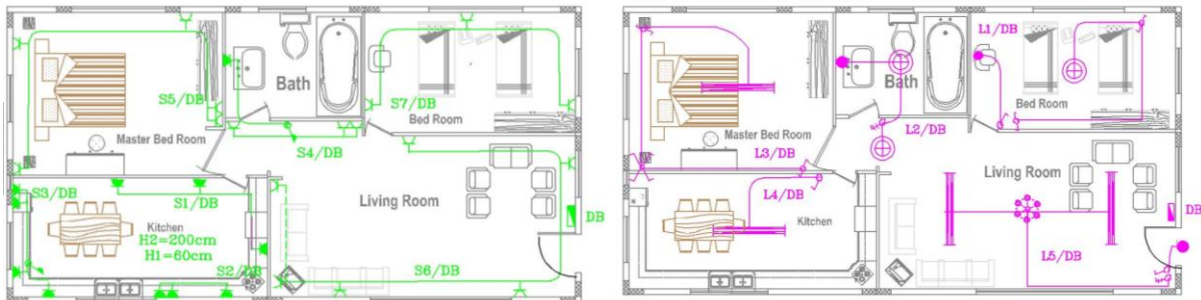

**Faculty of Engineering and Technology**  
**Electrical and Computer Engineering**  
**Department**

*Electrical Drawings and Installations Laboratory*  
*ENEE 4202*



*PREPARED BY*

*Electrical and Computer Engineering Department*

**2015**

elect

# Table of Contents

<b>Experiment # 1</b>	<b>Introduction to AutoCAD</b>	<b>Page 3</b>
<b>Experiment # 2</b>	<b>Electrical Symbols</b>	<b>Page 37</b>
<b>Experiment # 3</b>	<b>Single Phase Electrical Drawings</b>	<b>Page 51</b>
<b>Experiment # 4</b>	<b>Single Phase Electrical Plan Design</b>	<b>Page 63</b>
<b>Experiment # 5</b>	<b>3 Phase Electrical Plan Design</b>	<b>Page 69</b>
<b>Experiment # 6</b>	<b>Engineering Drawing</b>	<b>Page 83</b>
<b>Experiment # 7</b>	<b>Introduction to Electrical Installation Components</b>	<b>Page 113</b>
<b>Experiment # 8</b>	<b>Distribution Board and Extra Low Voltage Installations</b>	<b>Page 123</b>
<b>Experiment # 9</b>	<b>Implementation of Lighting Installations</b>	<b>Page 137</b>
<b>Experiment # 10</b>	<b>Implementation of Power Installations</b>	<b>Page 151</b>
<b>Experiment # 11</b>	<b>Introduction to Three-Phase Installations</b>	<b>Page 161</b>

## Experiment # 1

### Introduction to AutoCAD

➤ **Objectives:**

In this experiment we will learn to:

1. Start AutoCAD and open a new drawing, draw a line, a series of lines, and an object, select objects, and delete objects.
2. Use dynamic input to enter commands, zoom, pan, and to find more information on using AutoCAD.
3. Display only the relevant tools specific for your drawing environment, set the drawing units, and set the plot scale.
4. Do specify drafting settings, draw a circle, lines, and draw an arc.
5. Align objects and visualize the distances between them, determine precise locations of objects in a drawing, and Specify angles and distances.
6. Organize drawings with layers, and modify object properties by changing layer properties
7. Use some commands such as mirror, offset, array, move and rotate in drawing objects.

➤ **Introduction:**

AutoCAD is a Computer Aided Design software produced by Autodesk, Inc. It was the first CAD program to be available for use on personal computers. AutoCAD is one of the most popular Computer Aided Design programs developed to help professionals design and analyze products, buildings or structures without having to draw up plans manually. While CAD applications prior to AutoCAD involved large amount of computing power in the form of gigantic computers, AutoCAD has simplified its operations to optimize it for the IBM PC, allowing people to work from home or on their own workstations.

AutoCAD has many built-in tools to help architects or designers work on individual projects.

The software is comprehensive in its nature focusing more on 2D/3D renderings and also incorporates industry standards for product design and animation. The software gives seamless integration between other software and low cost high-speed prototyping is in many ways changing the way design is being carried out, and has by and large eradicated barriers to entry.

AutoCAD design can only be performed by skilled AutoCAD professionals to get accurate drawings solutions in quick turn-around time. Many companies today offer outsourced AutoCAD drafting & design services by acting as an extension to your in-house team allowing you to save on overheads and training costs.

Every Engineer communicates with a common language called “Engineering Drawings”. The technique of producing engineering drawings is DRAFTING. **AutoCAD** is used as a standard for Drafting worldwide.

➤ **Procedure:**

➤ **To start AutoCAD:**

To open AutoCAD, click Start menu (Windows) > (All) Programs > Autodesk > AutoCAD 2011 > AutoCAD 2011- English.

**NOTE: Close the Welcome Screen, if displayed.**

The AutoCAD window opens with an empty drawing file named : Drawing1.dwg.

Before moving on to the next lesson, become familiar with the areas of the AutoCAD window labeled below

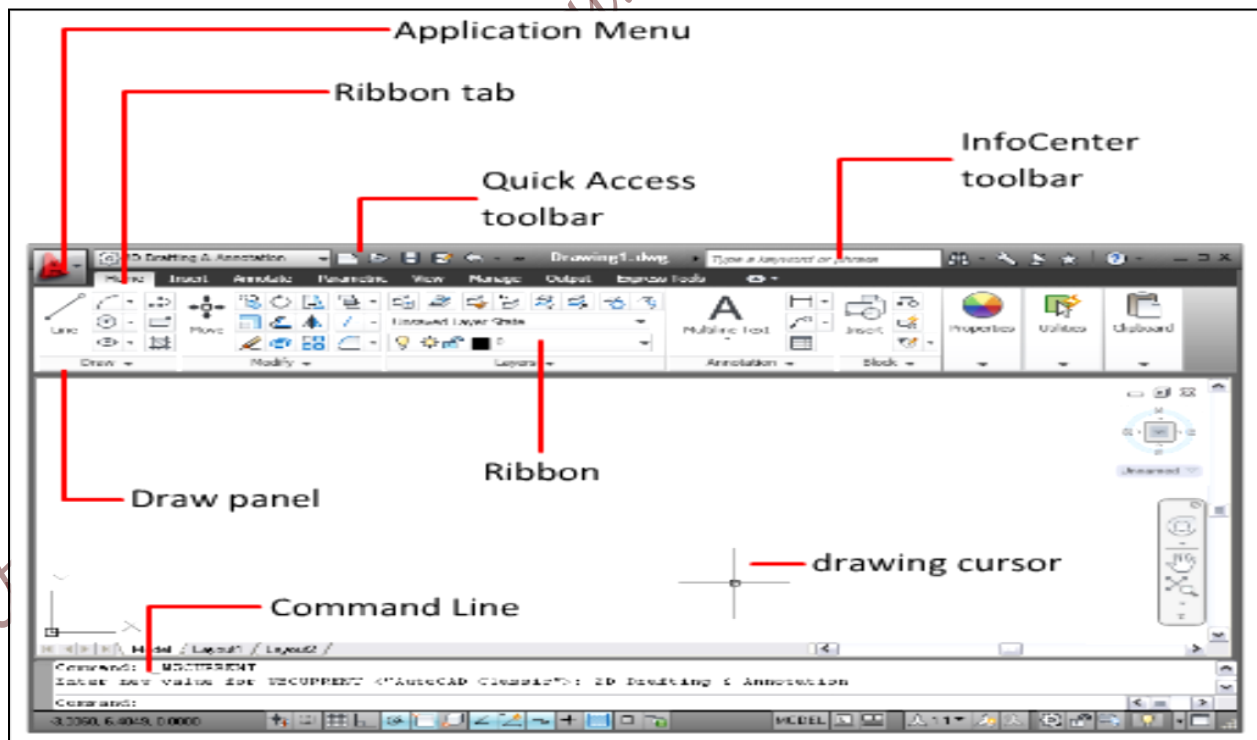



- **Undo - How to start over :** If you are stuck, and want to start a lesson over, you can use the Undo command. Click the Undo icon on the Quick Access toolbar, which is located at the top of the window. You may need to click it few times to undo all previous commands.



- **Esc - Cancel a command:**

If you accidentally click in the drawing area, display a shortcut menu, or start a command, you can always escape by pressing the Esc key on your keyboard.

➤ **Draw Lines:**

1. On the ribbon, click Home tab ➤ Draw panel ➤ Line. 

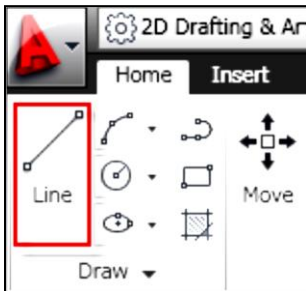

2. Drag the mouse down to the empty drawing. A crosshairs cursor appears with three text boxes. The “Specify first point” box is called the dynamic prompt. With the dynamic prompt, you can keep your eyes on your work and do not have to look down to the command line.

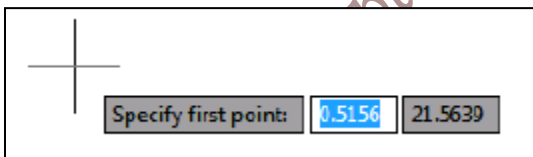

**NOTE :**If the dynamic prompt is not visible, press the F12 key to turn it on.

3. The other two text boxes show the location (x and y coordinates) of the cursor. Use the mouse to move the cursor around and notice that the coordinates change.
4. In the empty drawing, click on the left hand button of the mouse to pick a start point for your first line. The dynamic prompt changes to “Specify next point or”.

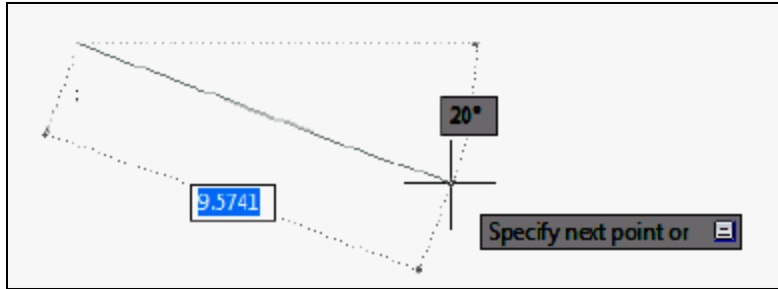

5. Drag the cursor in any direction and click on the mouse left button to pick up the end point of your line. Other text boxes appear with additional information about the line. You can ignore these for now.
6. Press the Enter key on your keyboard to end the line. You have drawn your first line!

➤ **To select and delete a single line:**

1. Move the cursor over the line to highlight it; the line will appear darker and dotted.
2. Click the mouse left button to select the line. You know it is selected when three square selection handles appear and the line changes to a dotted line.

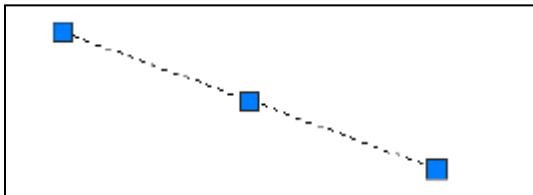

3. Press the Delete key on your keyboard to erase the line. You have learned how to select a single object and delete it.

➤ **Zoom and Pan with the Mouse Wheel:**

1. The easiest way to zoom in and out in your drawing is with the mouse wheel.
2. With the cursor in the drawing area, to zoom in and magnify a section of the drawing, scroll the mouse wheel up. To zoom back out, scroll the mouse wheel down
3. To display the entire drawing in the drawing area, double-click the mouse wheel.

➤ **To pan the drawing using the mouse wheel:**

You can pan your drawing to reposition the view without changing the magnification level.

1. With the cursor in the drawing area, press and hold down the mouse wheel. A hand icon appears.

2. Drag the mouse to pan the drawing.
3. Let go of the mouse wheel to stop panning.
4. Zoom in using the mouse wheel, and then pan the drawing. Notice that the magnification stays the same as you pan.

5. Before moving on to the next lesson, click  ➤ Close to close your drawing. Do not save it.

➤ **Use InfoCenter to Access Online Help and Other Information:**

InfoCenter is located in the upper right corner of the AutoCAD window.

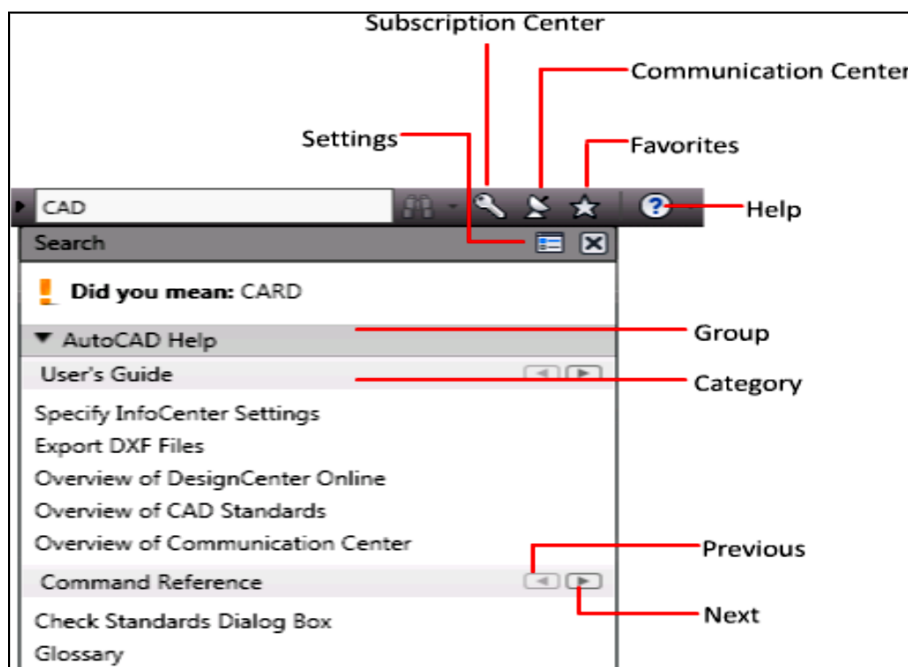

To search with InfoCenter:

1. In the InfoCenter Search text box, enter CAD. On the Search icon (binoculars), click the drop-down and select the location to search.

The search results for CAD are displayed for the selected location.

2. To browse the search results, click the next (right arrow) or previous (left arrow) button.

In the case of a misspelled word, spelling suggestions are displayed on a panel.

➤ **To start a drawing with a template:**

1. Click  ➤ New ➤ Drawing.

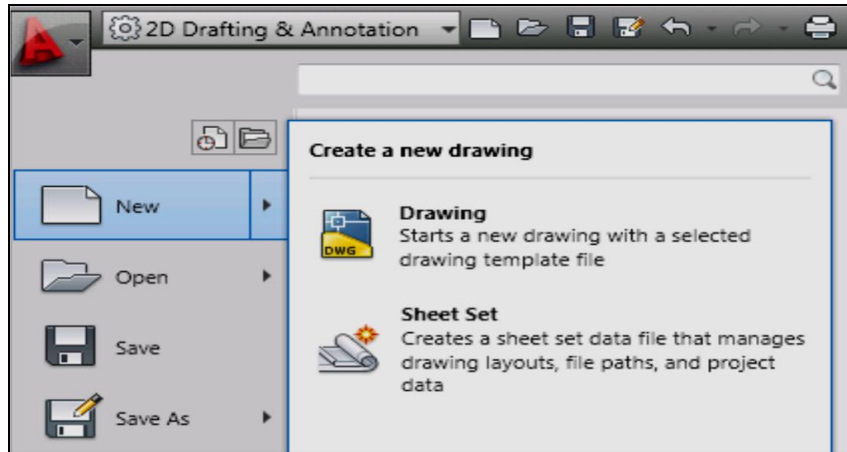

2. In the Select Template dialog box, select initial setup-electrical-metric.dwt.

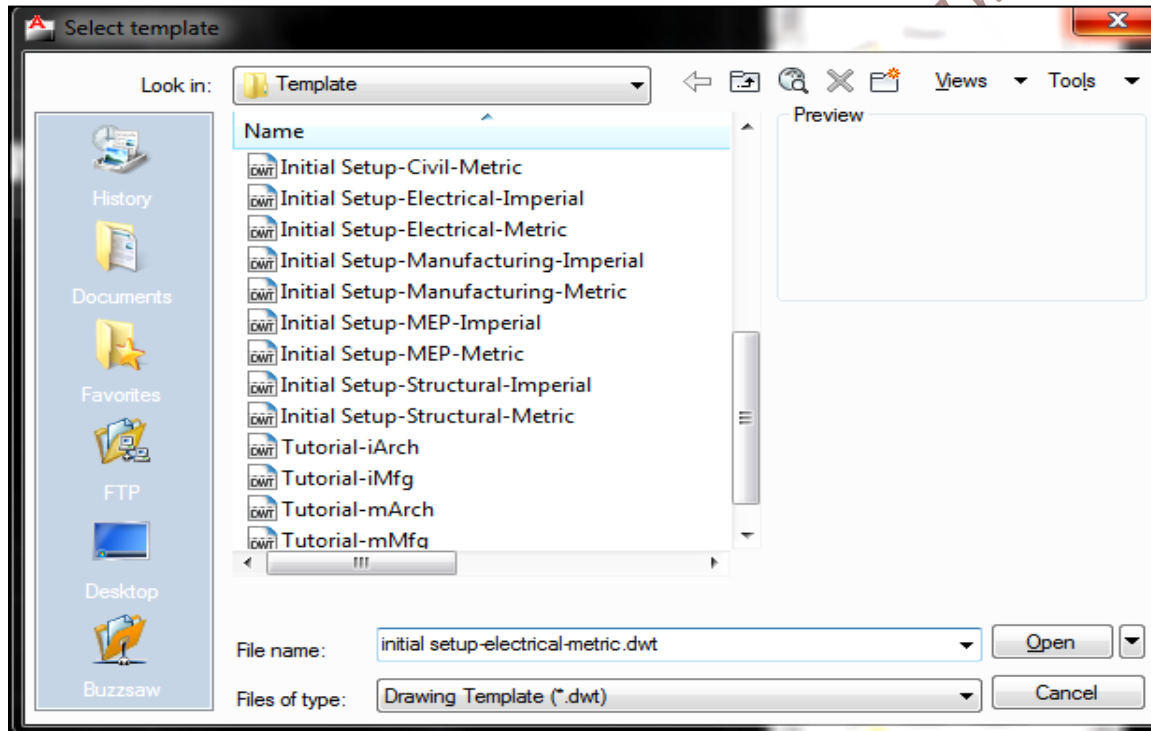

3. Click Open to open the initial setup-electrical-metric.dwt template.

Notice that the file name at the top is Drawing2.dwg. You are not opening the initial setup-electrical-metric.dwt file template file, but you are opening a new drawing based on the template file.

The initial setup-electrical-metric.dwt template file is used for electrical drawings, and includes predefined settings for drawing units, dimension style, linetype, layer, boarder and title block.

When you use a template file, you can start your drawing immediately without having to spend time defining settings and styles.

4. Click  ➤ Close ➤ Current Drawing to close Drawing2.dwg.

### ➤ Switch Workspace:

The workspace is the AutoCAD window layout of dockable windows, menus, toolbars, and other user interface features. You can select a predefined workspace or define your own. In this lesson, you will learn how to select the predefined workspaces, including the workspace for creating a 3D model. When you use a workspace, only the menus, toolbars, ribbon tabs, and palettes relevant to a task are displayed.

#### **To Switch Workspaces:**

1. The status bar is located at the bottom right of the window. The Workspaces icon on the status bar is shown below.



**NOTE** If you do not see these icons, right-click in an empty area on the status bar and click **Workspaces**. If you still do not see this icon, you may need to maximize the AutoCAD window.

2. Click the down arrow in AutoCAD class bar at the right top to display the menu of predefined workspaces.
3. On the Workspace menu, click 3D Modeling.
4. The 3D Modeling workspace is displayed. The Workspaces icon in the status bar indicates that you are now in the 3D Modeling workspace. In this Workspace, you can access the various commands and tools needed for creating 3D drawings. For example, notice the 3D modeling commands available in the ribbon.

**NOTE:** The selected Workspace is retained when you close and reopen AutoCAD. To return to 2D Drafting & Annotation, you must select it.

### ➤ Select the Drawing Units:

In this lesson, you will learn how to set the drawing unit and the scale for a drawing.

Before you start a drawing, you must first decide what drawing units to use. In AutoCAD, distances are measured in drawing units. In a drawing, one drawing unit may equal one inch, one millimeter, one meter, or one mile. Before you begin drawing, you decide what one drawing unit will represent. AutoCAD does not include a setting that determines the length of a drawing unit.

After you decide what drawing units to use, you can set the format of the drawing units. The format settings available for linear units include

- Architectural. A length of 15.5 units displays as 1'-3 1/2"
- Decimal. A length of 15.5 units displays as 15.5000
- Engineering. A length of 15.5 units displays as 1'-3.5"
- Fractional. A length of 15.5 units displays as 15 1/2
- Scientific. A length of 15.5 units displays as 1.5500E+01

For example, a mechanical engineer who works in millimeters would set the format for linear units to decimal. An architect who works in feet and inches, would set the format to architectural.

The drawing unit format controls only the display style of the drawing units on-screen, such as in the display of coordinates and values in the dialog boxes and prompts.

**To set the format of the drawing units:**

1. Click  > Drawing Utilities > Units.

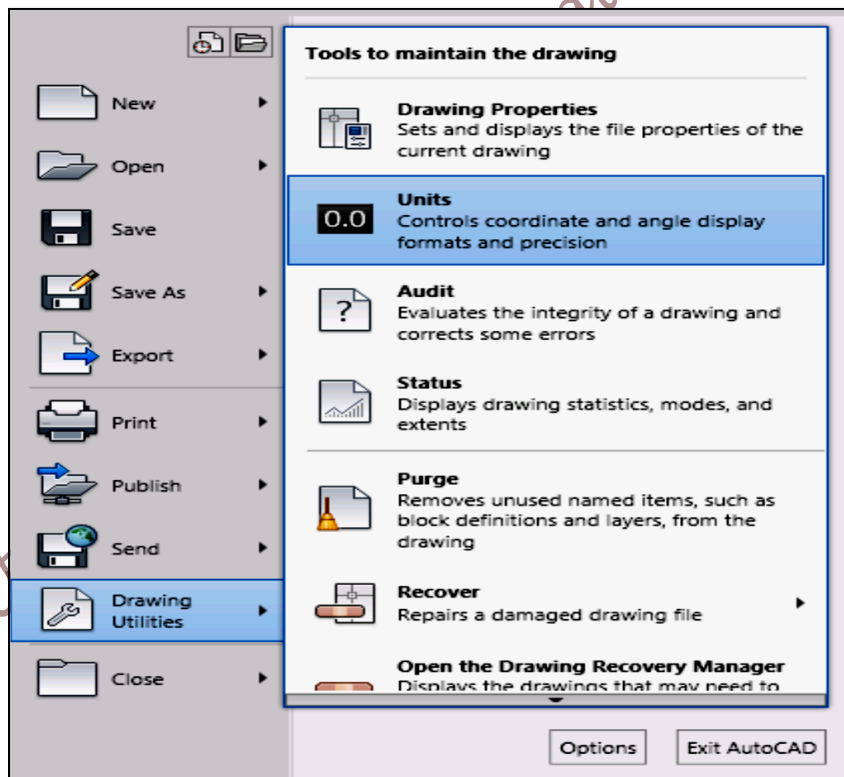

In the Drawing Units dialog box, under Length, select the following values:

- Type: Decimal
- Precision: 0.00

Change the setting as shown in the figure below:

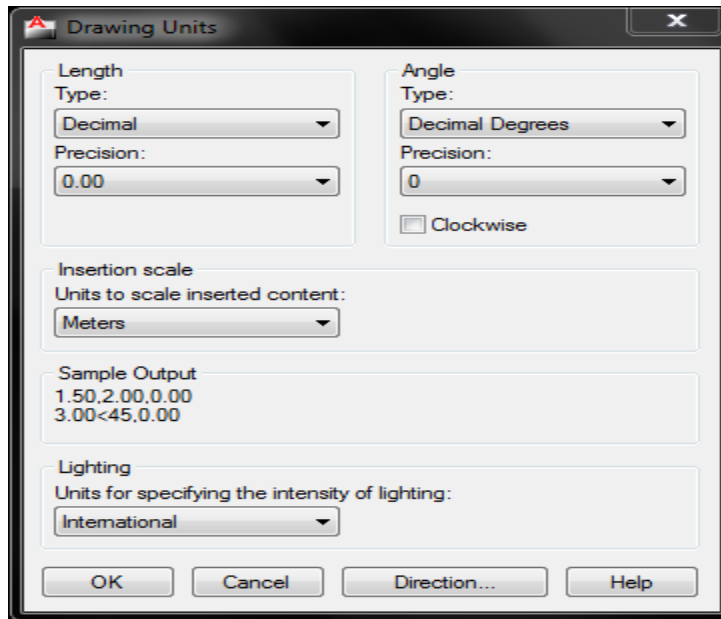

2. Click Ok, then close the dialog box.

### ➤ **Set the Plot Scale:**

When you plot a drawing, you either specify a precise scale or fit the image design to the current paper size. For example, a distance of one drawing unit typically represents one millimeter or one meter in a metric drawing, while one inch or one foot in real-world units are common in an imperial drawing.

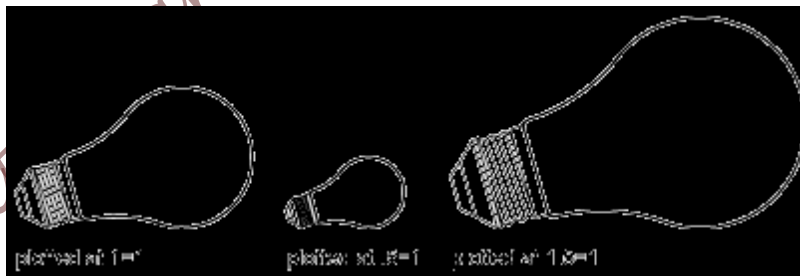



### **To plot using a custom scale:**

1. Click ➤ Open ➤ Drawing and select Electrical Power.dwg in the Select File dialog box.

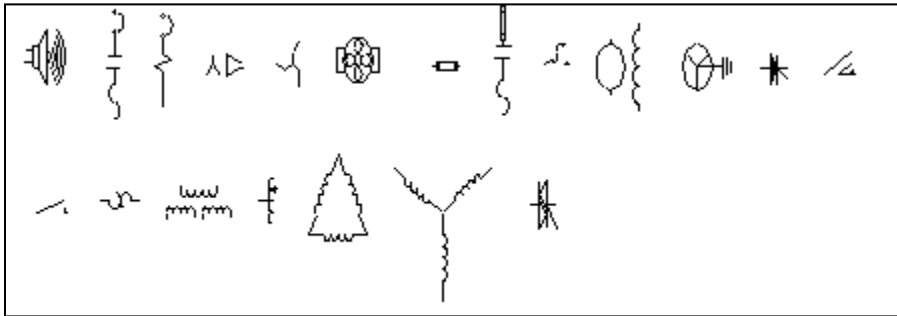

C:\Autodesk\AutoCAD\_2010\_English\_Win\_32bit\_SLD\x86\acad\Program  
Files\Root\Sample\DesignCenter



2. Click  > Print > Plot .
3. In the Plot dialog box, under Page setup, click Add.

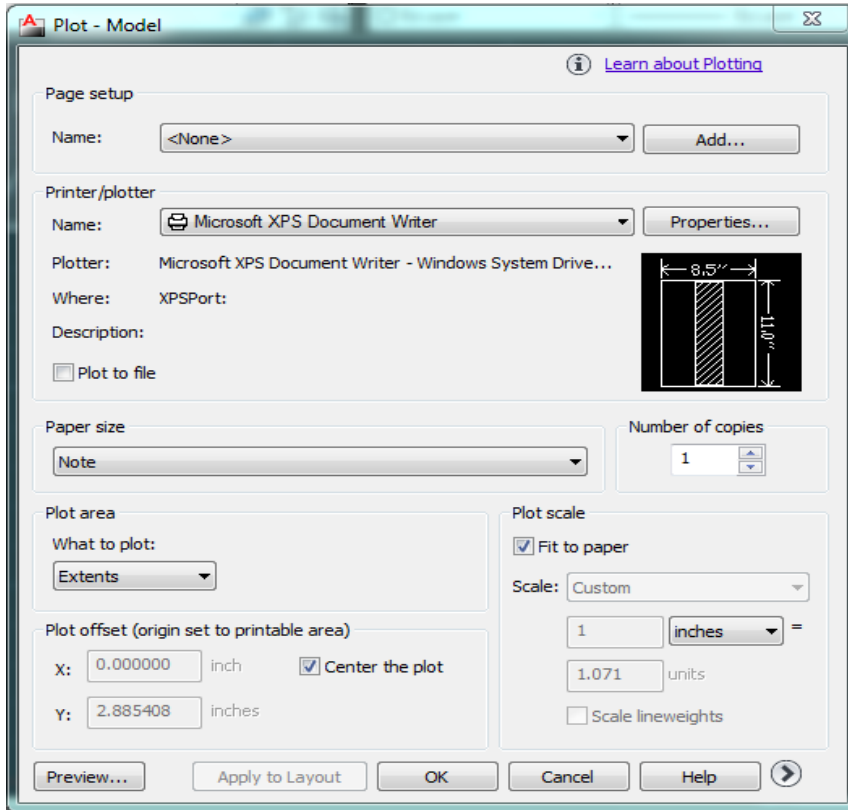

4. In the “Add Page Setup” dialog box, enter MySetup. Click OK.

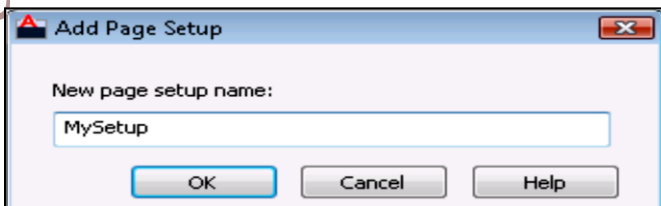

5. Under Printer/plotter, Name list, select your printer to plot the current layout.
6. Select Fit to paper check box.  
**NOTE If the Fit to paper check box is selected, the Scale list is not available.**
7. To change the scale of drawing, don't use fit to the paper, so the scale list is available.
8. Enter the value you need as in the next figure

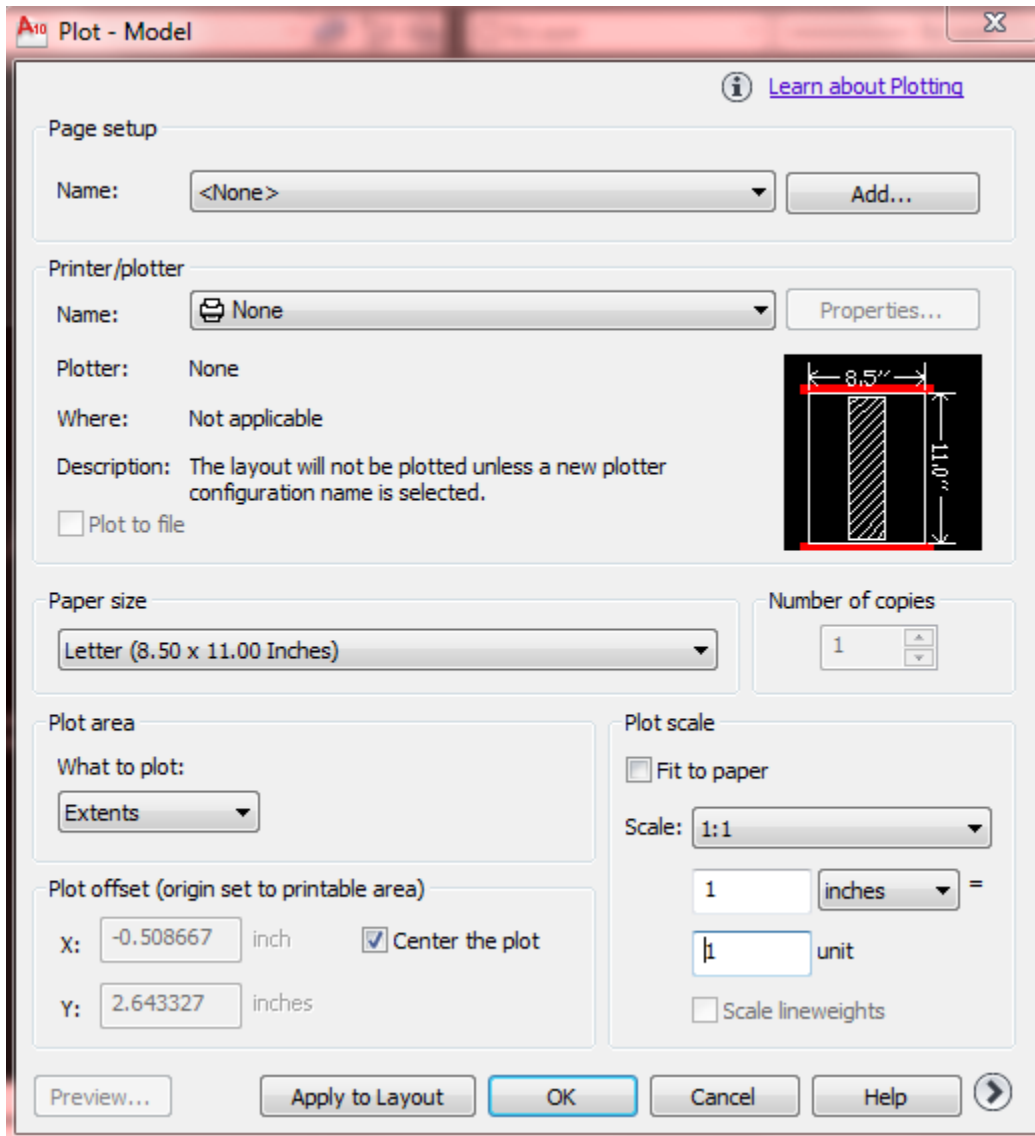

9. Click Preview.

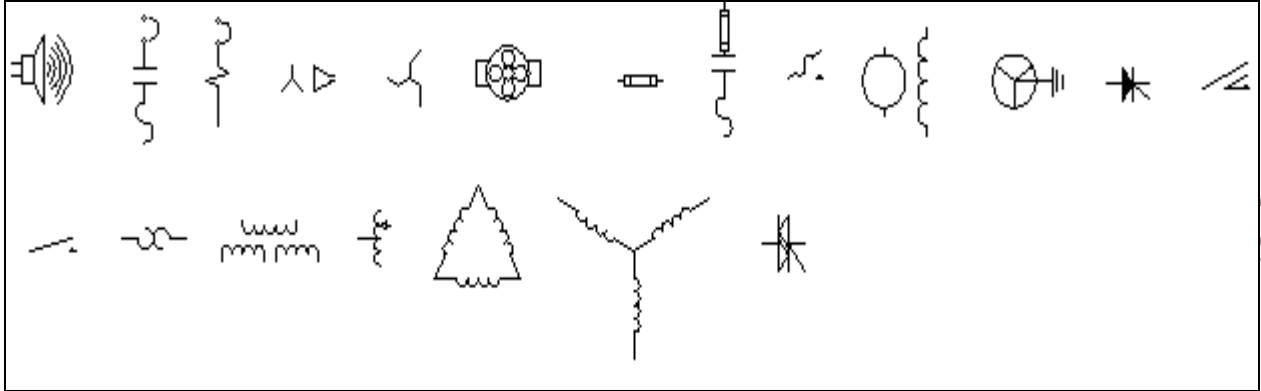

10. In the preview window, click Plot to print the drawing.

11. Click to close the preview window, and click Cancel to close the Plot dialog box.

➤ **Specify Drafting Settings:**

1. Check the status bar to make sure you are in the 2D Drafting & Annotation workspace.

2. Right-click the Object Snap icon in the status bar at the bottom of the window, and select Settings. 

3. The Drafting Settings dialog box is displayed. In the Object Snap tab, make sure that the Object Snap On option is selected. Also, select Endpoint, Midpoint, and Center for the Object Snap modes. Make sure that the other options are not selected. Select OK

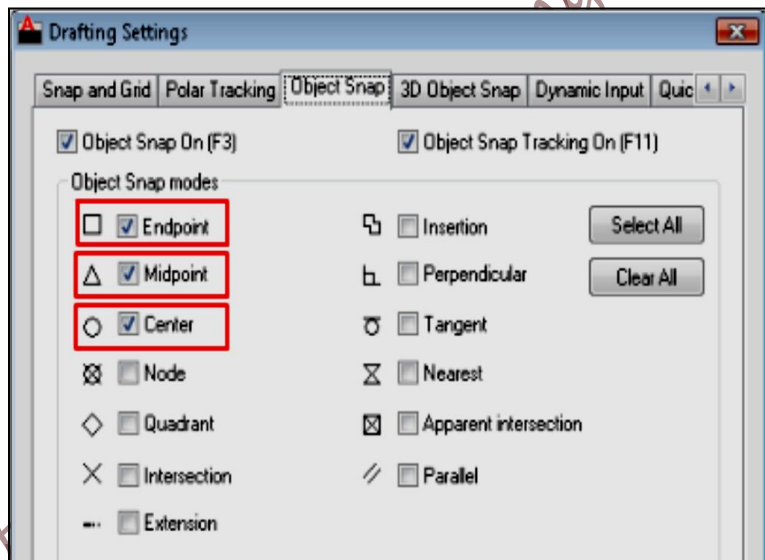

➤ **Draw a Circle:**

To draw a circle

1. With Drawing1.dwg open, on the ribbon, click Home tab ➤ Draw panel > Circle drop-down menu ➤ Center, Radius. 
2. Drag the crosshairs cursor down to the drawing area.
3. Click the left mouse button to specify the center of the circle.
4. The dynamic input prompt asks you to “Specify radius of circle.” Enter 3.25 from the keyboard and press the Enter key to create a circle with a radius of 3.25.

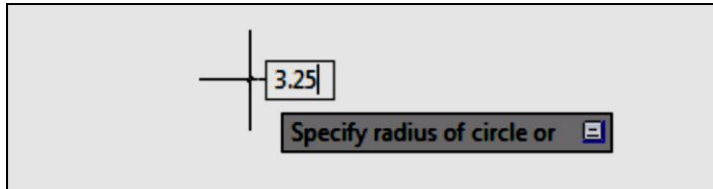

5. Click > save and save drawing as circle.dwg to your desktop.
6. Draw a Polygon inside your circle.

### ➤ **Modify Object Properties:**

To display the properties of objects:

1. Check the status bar to make sure you are in the 2D Drafting & Annotation workspace and the Show/Hide icon is turned on.
2. Draw the following in your sheet.

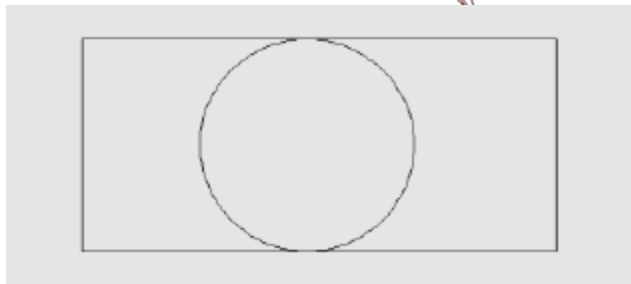

3. In the drawing area, select the rectangle by clicking it.
4. With the rectangle selected, on the ribbon, click View tab ➤ Palettes panel ➤ Properties.

The Properties palette displays the properties of the selected rectangle.

5. In the Properties palette, specify the following:

- Color: Red
- Lineweight: 0.70 mm

The thickness of the rectangle sides are increased by 0.70 mm.

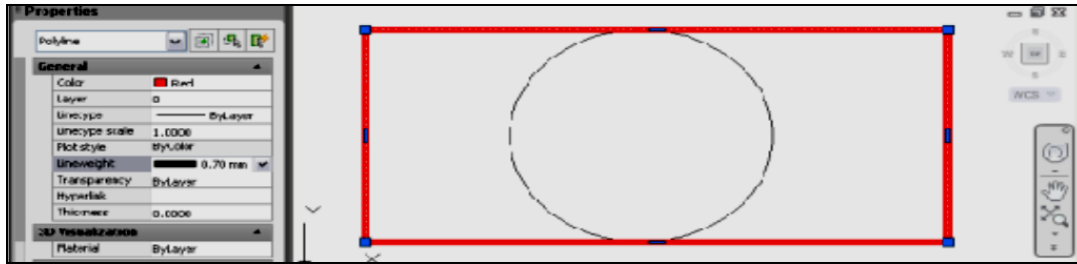

Similarly, you can change other properties of the rectangle from the Properties palette.

6. Press Esc to deselect all selected objects

### To change the properties of a circle:

1. Before changing the properties of the circle, you must first load a linetype. Click Home tab > Properties panel > Linetype.

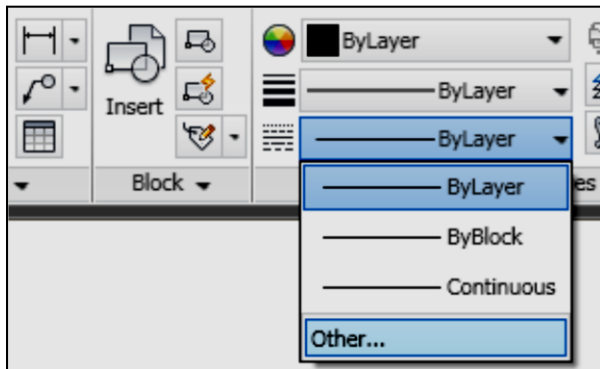

2. In the Linetype drop-down list, click Other. Then, in the Linetype Manager dialog box, click Load.
3. In the Load or Reload dialog box, select the DOT linetype. Click OK.
4. Click OK.
5. Select the circle by clicking it.

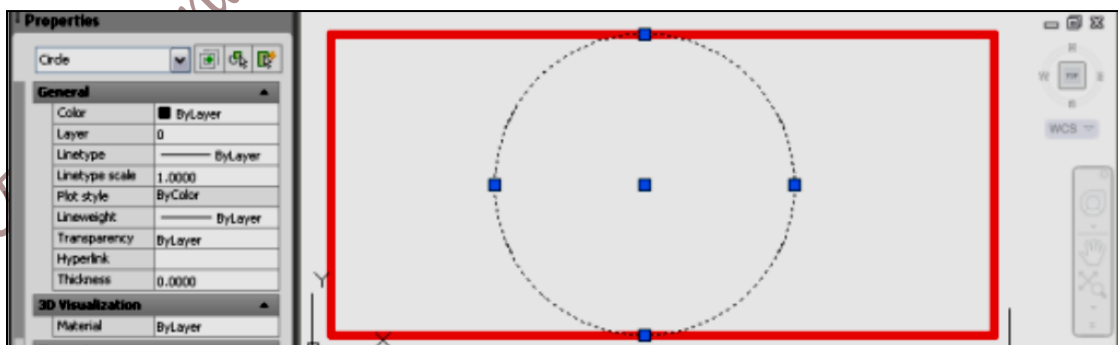

6. If the Properties palette is not displayed, then on the ribbon, click View tab > Palettes panel > Properties.

The Properties palette displays the properties of the selected circle.

7. In the Properties palette, do the following:

- Under the Geometry category, select Radius and enter 3 to replace the current value.

The radius of the circle changes to the value you entered.

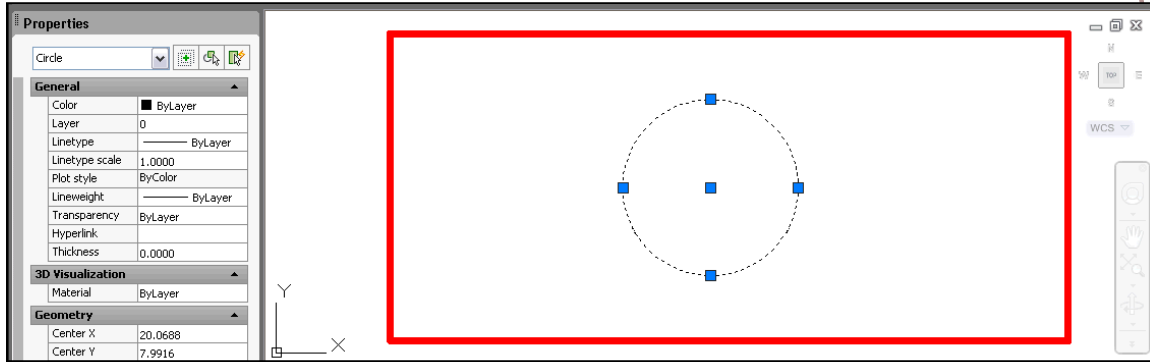

Under the General category, select Linetype and select DOT from the drop-down list.

The circle is now displayed with the DOT linetype.

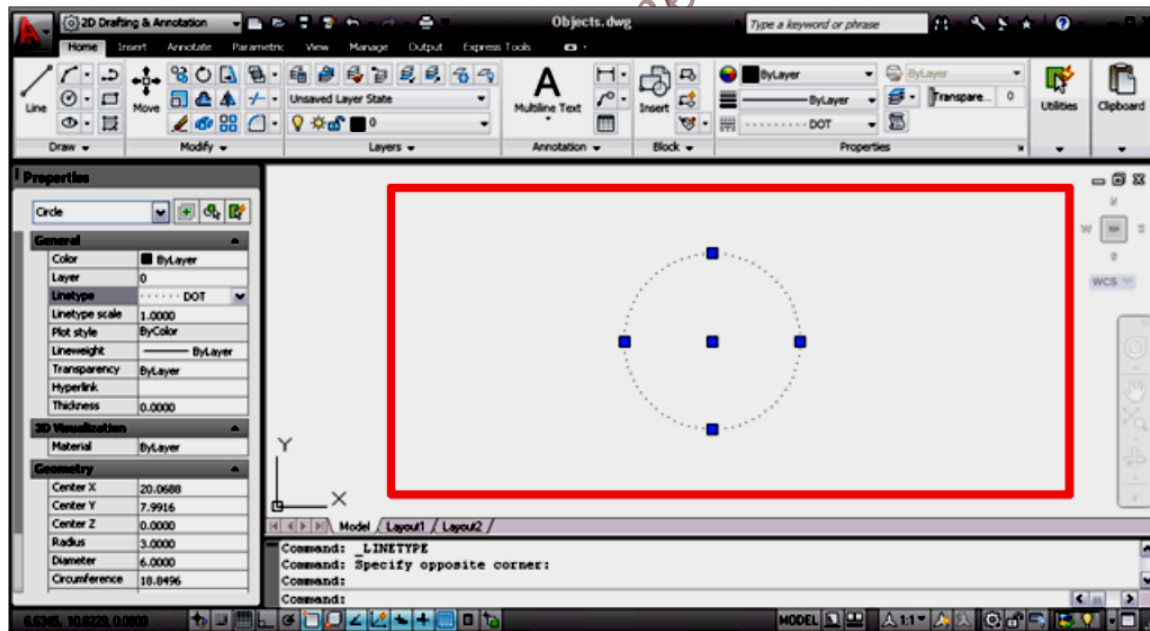

You can change other properties of the circle from the Properties palette.

## ➤ Organize Drawings with Layers:

To create a new layer

1. Click  ➤ New ➤ Drawing.
2. In the Select Template dialog box, select acad.dwt and click Open.
3. On the ribbon, click Home tab ➤ Layers panel ➤ Layer Properties.

Its appears as icon (  )

The Layer Properties Manager palette is displayed.

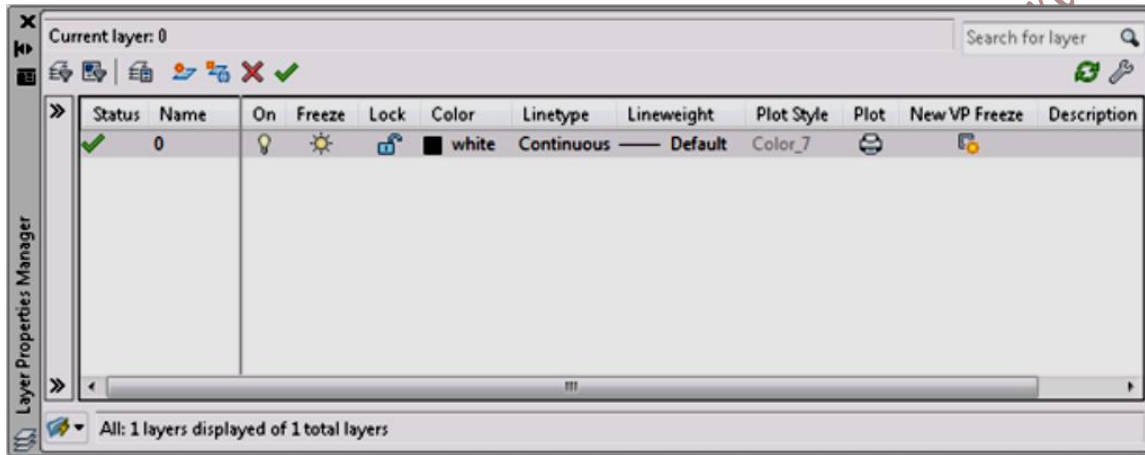

For ease of use, you can dock the Layer Properties Manager. Right click on the layer Properties Manger and click Anchor Left or Anchor Right.

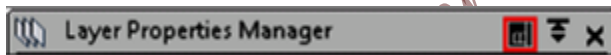

On the Layer Properties Manager, click the New Layer icon.(at the top of the window)



A new layer named Layer1 is automatically added to the layer list.

4. In the in-place editor, enter Green Gas as the new layer name by overwriting the default highlighted layer name.
5. In the Color column of the Green Gas layer, click White. In the Select Color dialog box, Index Color tab, click the Green color and click OK.



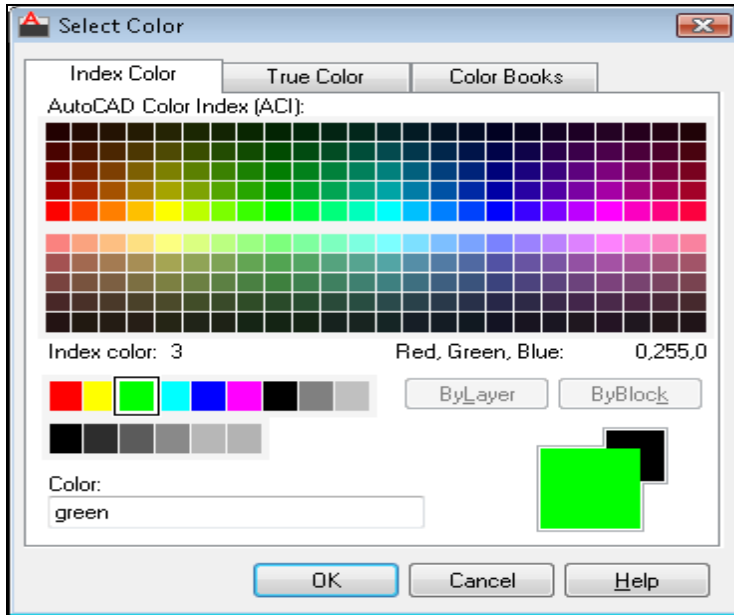

In the Linetype column of the Green Gas layer, click Continuous. In the Select Linetype dialog box, click Load.

6. In the Load or Reload Linetypes dialog box, Available Linetypes list, select GAS\_LINE and click OK.

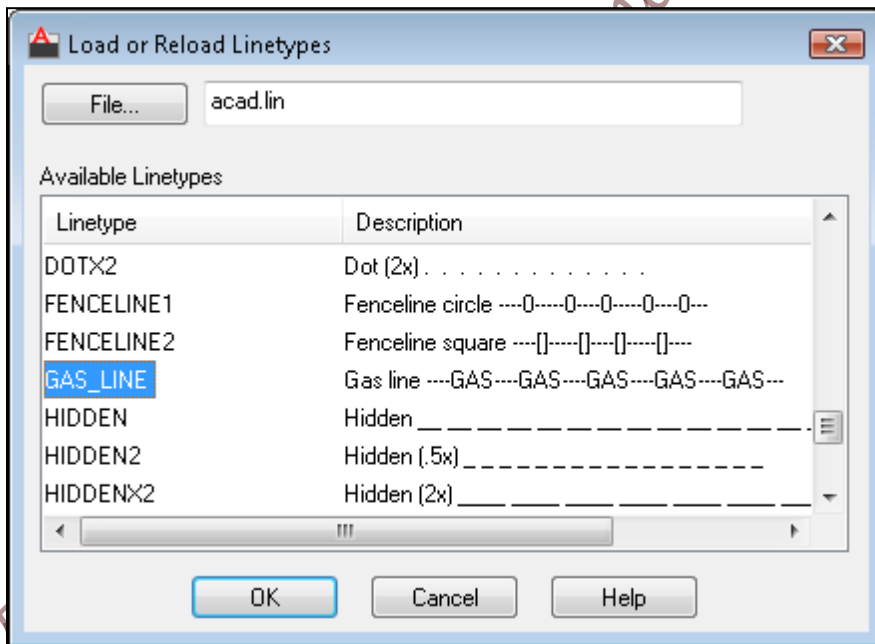

In the Select Linetype dialog box, Loaded Linetypes list, select the GAS\_LINE and click OK.

7. In the Lineweight column of the Green Gas layer, click Default. In the Lineweight dialog box, Lineweights list, select 1.00 mm and click OK

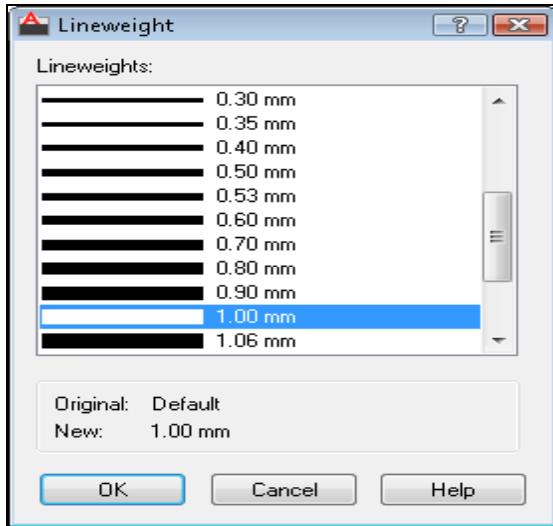

Click the Set Current button.



The Green Gas layer is now active. Objects that you draw, with this layer active, will inherit the properties as you have defined them.

- On the ribbon, click Home tab > Draw panel > press on Line icon. Specify two points in the drawing area to create the line and press Enter to end the command.

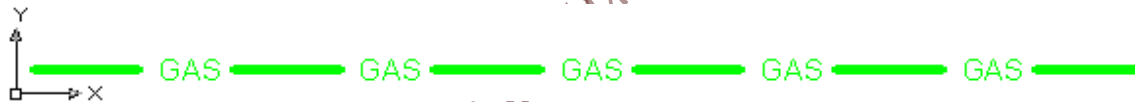

You should see that the line is in green with the GAS\_LINE linetype and a thickness of 1.00 mm.

**NOTE: Icon (mark below) To display the lineweights in your drawing, on the status bar, click Show/Hide Lineweight.**

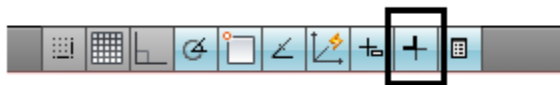

You have drawn a line on the Green Gas layer. All other objects you draw on this layer will inherit the layer properties. To add more layers, follow the same procedure and modify the color, linetype, lineweight properties as needed.

To help identifying what each layer in your drawing is used for, you can provide a description in the Description column of the Layer Properties Manager.

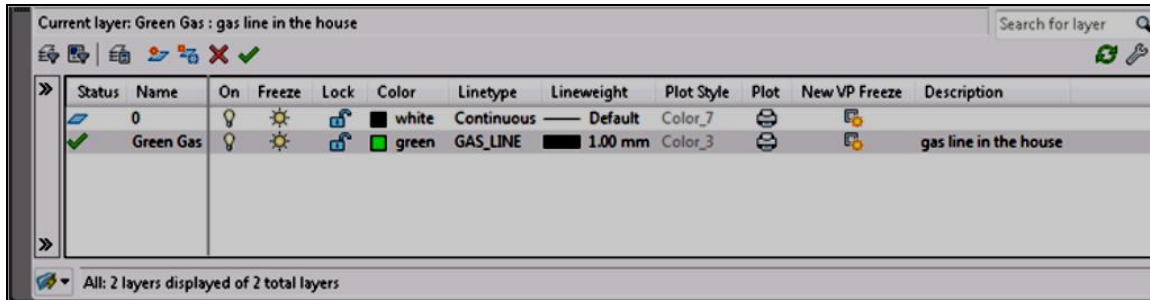

When you are working on complex drawings, your drawing can get crowded. Turning off a layer hides all objects in that layer from view. By doing so, you can concentrate on the layer you are working on.

To control the visibility of objects by turning off and turning on layers

1. Ensure that the Layer Properties Manager is open. If the Layer Properties panel is not open, on the ribbon, click Home tab > Layers panel > Layer Properties.
2. On the Layer Properties Manager, select the Green Gas layer and click the light bulb in the On column. If the light bulb is yellow, the layer is turned on.

Clicking the light bulb toggles the layer on and off. When a layer is turned off, you do not see the objects on at layer.

So far, you have learned to create layers, assign properties to layers, and control the visibility of objects using layers.

### ➤ **Set Grid and Snap Values:**

To display the grid

1. Check the status bar to make sure you are in the 2D Drafting & Annotation workspace.
2. On the status bar, click the Grid Display button to turn it on.

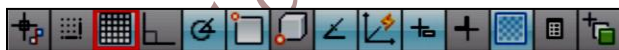

**NOTE :** If you do not see the Grid button, right-click the status bar and click Status Toggles

- Grid (F7)

A grid is displayed in the drawing area. Notice that it covers a limited area, the grid limits.



### To set grid spacing:

1. On the status bar, right-click the Grid button. Click Settings.
2. In the Drafting Settings dialog box, Snap and Grid tab, ensure that Grid On (F7) is selected.

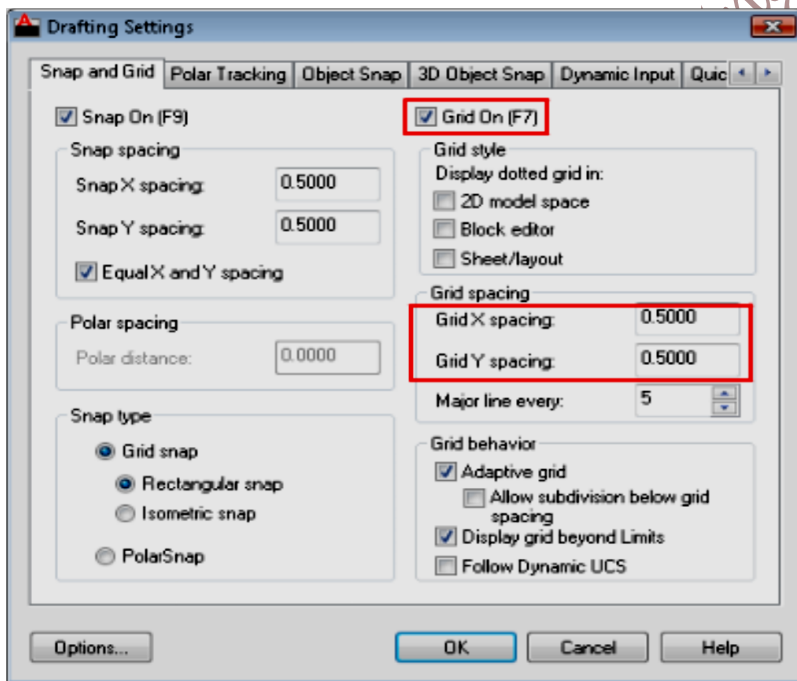

3. Under Grid Spacing, do the following:
  - In the Grid X Spacing box, enter 0.5000 to set the horizontal grid spacing in units.
  - In the Grid Y Spacing box, enter 0.5000 to set the vertical grid spacing in units.
4. Click OK.

### To set the grid limits:

1. The LIMITS command creates an invisible drawing boundary within the drawing area. At the Command prompt, enter limits. Press Enter.

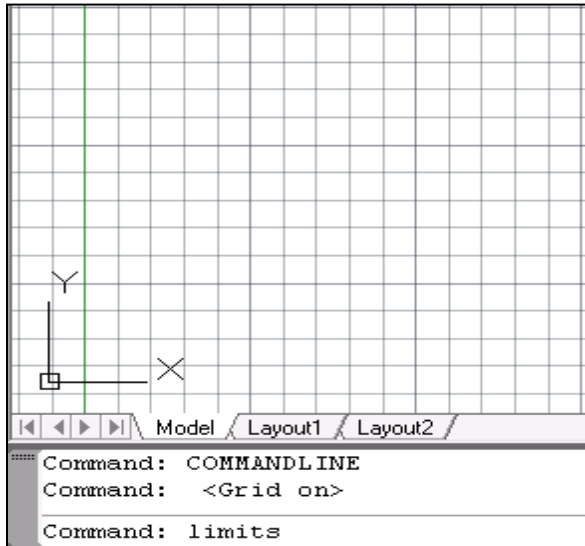

2. At the prompt, press Enter to accept the default coordinate value of 0,0 to specify the lower left corner of the drawing limits.
3. At the prompt, accept the default 12.0000,9.0000 (A-size sheet) or enter a required paper size, and press Enter to specify the upper-right corner of the grid limits.
4. At the Command prompt, enter limits.
5. Enter ON to enable the limits set. This sets the drawing limit, you cannot draw outside this limit. You may disable the limits by off command.

### To turn on Snap mode:

1. On the status bar, click the Snap Mode button to turn it on.



**NOTE** If you do not see the Snap Mode button, right-click the status bar and click Status Toggles - Snap (F9).

2. Move the cursor around in the drawing area while Snap mode is turned on. Notice that the cursor snaps to points at equal intervals in the drawing area.

### To set snap spacing:

1. On the status bar, right-click the Snap Mode button and click Settings.
2. In the Drafting Settings dialog box, Snap and Grid tab, ensure that Snap On (F9) is selected.

3. Under Snap Spacing, do the following:

- In the Snap X Spacing box, enter 0.5000 to set the horizontal snap spacing value in units.
- In the Snap Y Spacing box, enter 0.5000 to set the vertical snap spacing value in units.

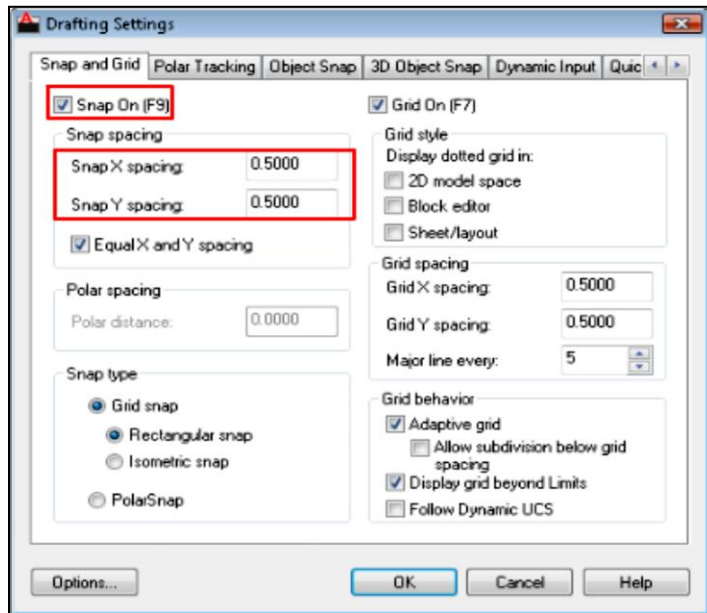

### ➤ **Snap to Precise Points on Objects:**

To display and enable object snaps

1. On the status bar, click the Object Snap button to turn it on







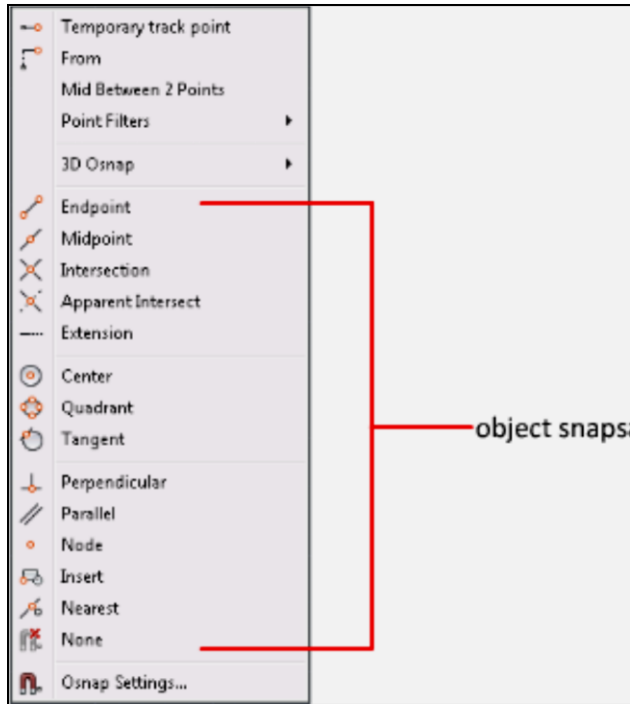

**NOTE** If you do not see the Object Snap button (OSnap), right-click the status bar and click **Status Toggles - OSnap (F3)**.









2. At any prompt that requests a point, you can specify a single object snap by holding down Shift, right-clicking, and choosing an object snap from the Object Snap menu.



The following table illustrates commonly used object snaps.

Object Snap		Snaps to
<b>Endpoint</b> 		Object endpoints
<b>Midpoint</b> 		Object midpoints
<b>Intersection</b> 		Object intersections or, for single object snaps, locations where intersections would occur if objects were extended



Center 		Center points of circles, arcs, or ellipses
Quadrant 		Quadrants of circles, arcs, or ellipses.
Perpendicular 		Points on objects that form a perpendicular alignment with the last point specified
Tangent 		Point on a circle or arc that, when connected to the last point, forms a tangent line to the object

### To specify an object snap:

1. With Drawing1.dwg open, on the ribbon, click Home tab > Draw panel > Line Icon.

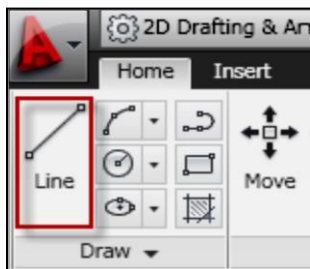

2. Draw a line in the middle of the drawing area.
3. On the ribbon, click Home tab > Draw panel > Circle drop-down > Center, Radius.
4. Press and while holding down Shift, right-click in the drawing area and select Midpoint from the Object Snap menu. This specifies the center point for the circle.

5. Move the cursor over the middle of the line space. If AutoSnap is on, the cursor should automatically lock onto the nearest midpoint object snap location and the marker and tooltip. Draw the shown figure using object snap.



Pick in the drawing area to snap to the midpoint of the line. Specify the radius of the circle as 2

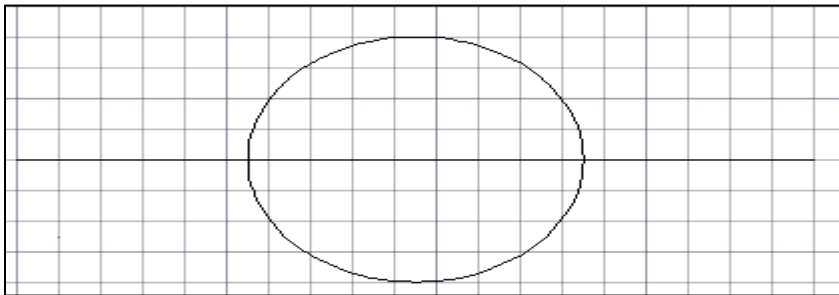

**To set running object snaps:**

1. On the status bar, right-click the Object Snap button and click Settings.
2. In the Drafting Settings dialog box, Object Snap tab, click Clear All and then select:
  - Endpoint
  - Midpoint
  - Center

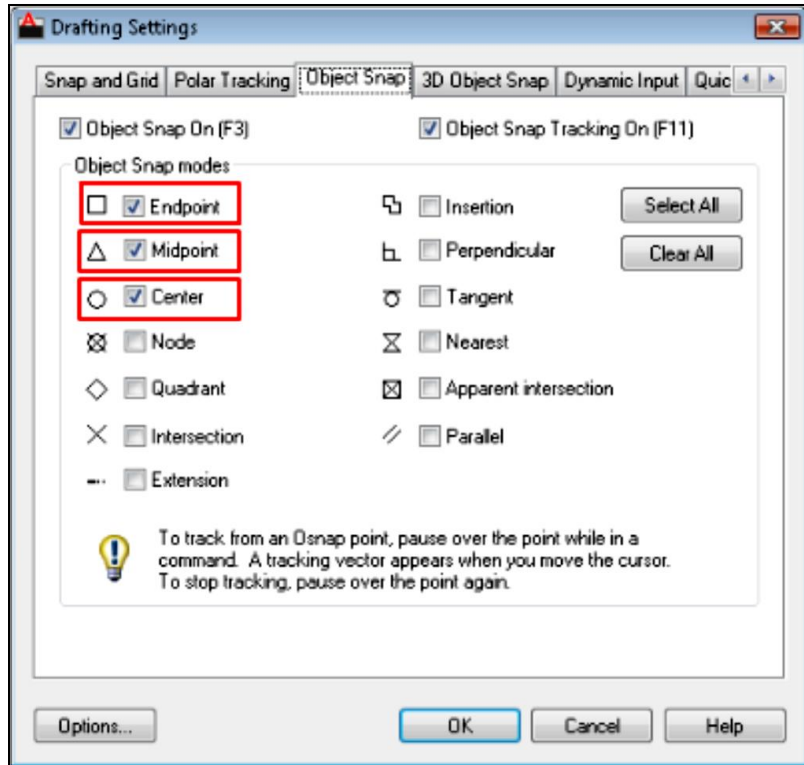

3. Click OK.
4. Draw several lines and circles using object snaps to locate points precisely.

➤ **Specify Angles and Distances:**

To display and turn on polar tracking

- On the status bar, click the Polar Tracking button to turn it on.

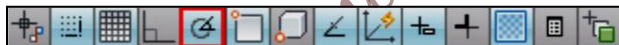

**NOTE** If you do not see the Polar Tracking button, right-click the status bar and click **Status Toggles > Polar (F10)**.

**To use polar tracking:**

1. On the status bar, right-click the Polar Tracking button and click Settings.
2. In the Drafting Settings dialog box, Polar Tracking tab, ensure that Polar Tracking On (F10) is selected.
3. Under Polar Angle Settings, do the following:
  - In the Increment Angle drop-down list, select 45.
  - Click New and enter 60 to add a custom polar angle. Additional angles

are absolute, not incremental.

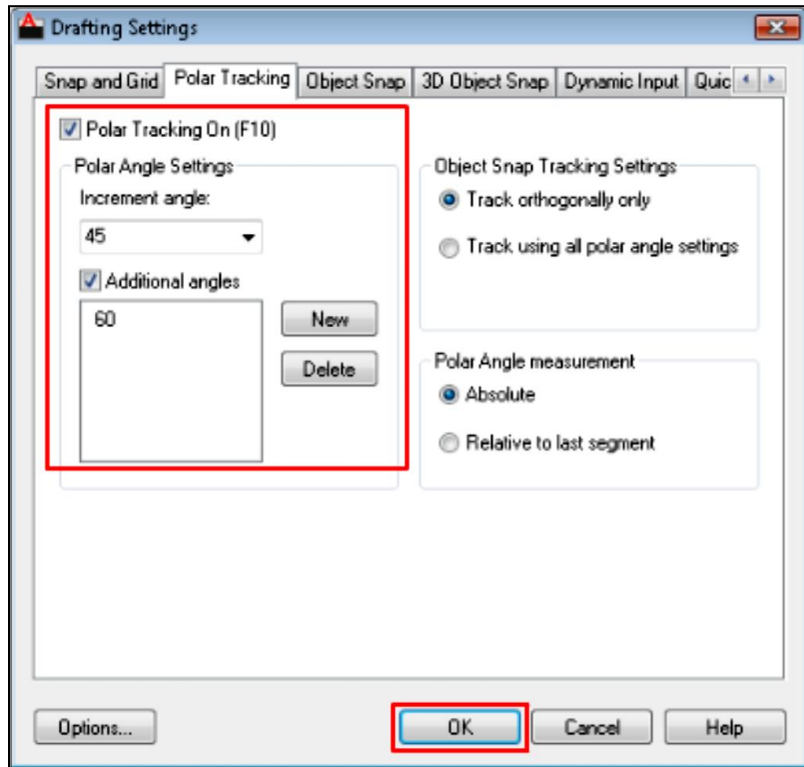

4. Click OK. Draw several lines at 45 and 60 degrees from each other. Notice that the lines snap to the angles specified. Delete the lines before going to the next exercise.

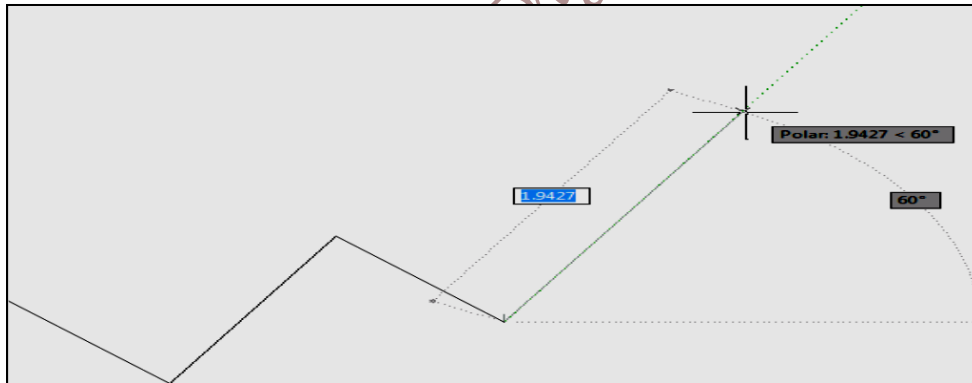

#### To draw objects using polar distance:

You can use direct distance entry to specify a coordinate value by moving the cursor to indicate a direction and then entering a distance from the previous point. When polar tracking is on, using direct distance entry helps you draw lines at a pre-defined angle with a specified length.

1. Ensure that Polar Tracking is on.

2. On the ribbon, click Home tab > Draw panel > Line.

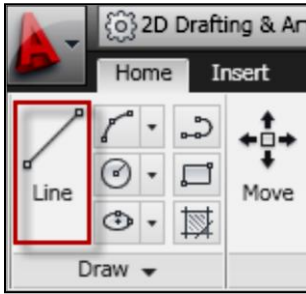

3. Click in the drawing area to specify the first point and then move the cursor to the right (0 degrees).
4. Enter 10 in the dynamic prompt to specify the distance and press Enter.
5. Move the cursor up 90 degrees, enter 5 to specify the next point, and press Enter.

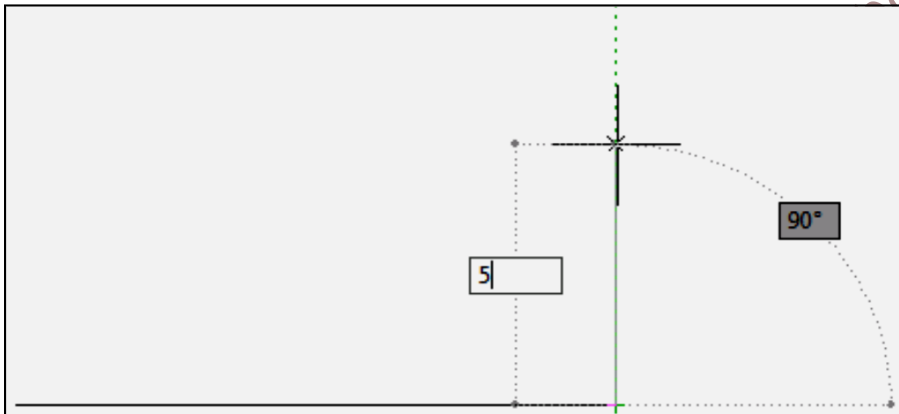

6. Repeat several more times and press Enter to finish. Delete lines before going to next exercise.

### To lock an angle for one point (angle):

If the angle that you want to use is not going to be used frequently, you can enter an angle override. For example, if you start drawing a line at the coordinate 5,5, and want that line to be at a 10 degree angle with a length of 20, you would do the following:

1. On the ribbon, click Home tab > Draw panel > Line.

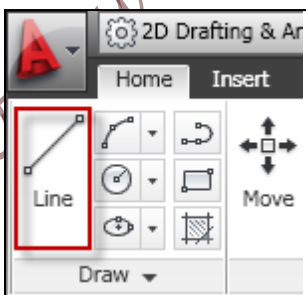

2. At the prompt, enter #5,5 to specify the first point and press Enter.

- At the prompt, enter <10 to enter the angle override, and press Enter.

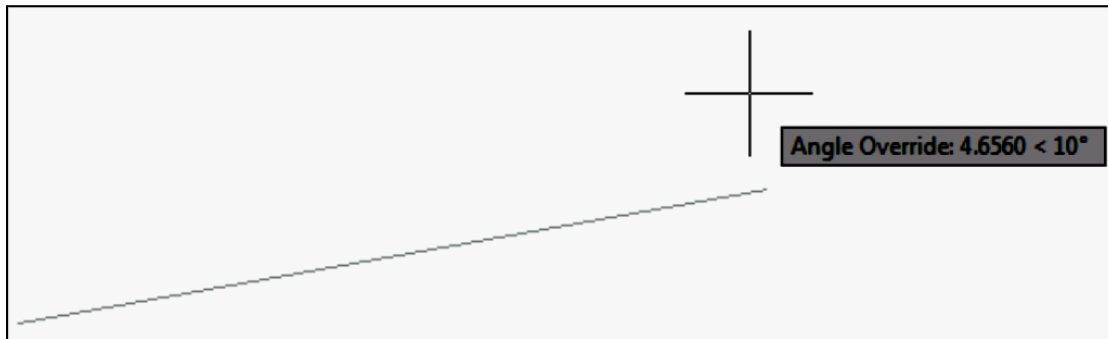

- Move the cursor in the desired direction.
- Enter 20 and press Enter. You have drawn a line at a 10 degree angle with a length of 20.

### How to use Modify tool:

Home tab ► Modify panel



### ERASE:

You can erase selected objects from the drawing. This method does not move objects to the Clipboard, where they can then be pasted to another location.

If you are working with 3D objects, you can also erase subobjects such as faces, meshes, and vertices.

Instead of selecting objects to erase, you can enter an option, such as L to erase the last object drawn, p to erase the previous selection set, or ALL to erase all objects. You can also enter ? to get a list of all options.

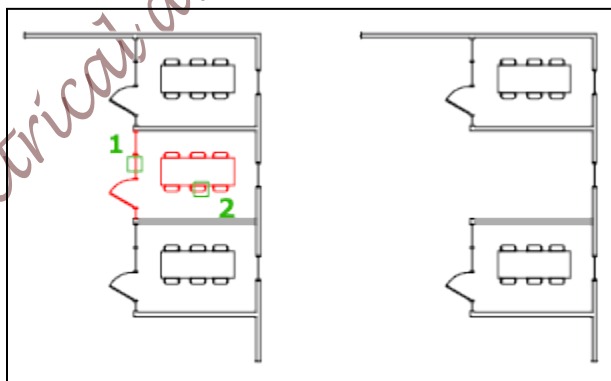

## MIRROR:

Creates a mirrored copy of selected objects.

You can create objects that represent half of a drawing, select them, and mirror them across a specified line to create the other half.

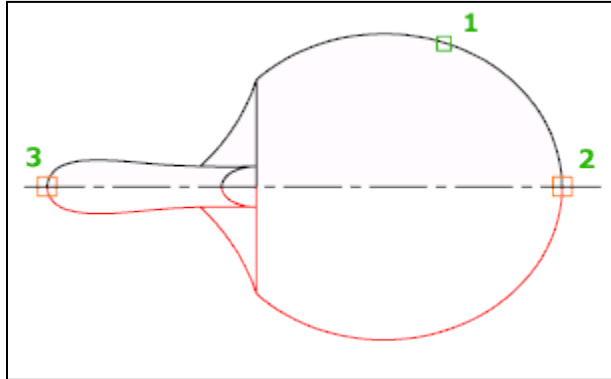

**Note:** By default, when you mirror a text object, the direction of the text is not changed. Set the MIRRTEXT system variable to 1 if you do want the text to be reversed.

## OFFSET:

Creates concentric circles, parallel lines, and parallel curves

You can offset an object at a specified distance or through a point. After you offset objects, you can trim and extend them as an efficient method to create drawings containing many parallel lines and curves.



The OFFSET command repeats for convenience. To exit the command, press Enter.

## ARRAY:

You can create copies of objects in a regularly spaced rectangular or polar array.



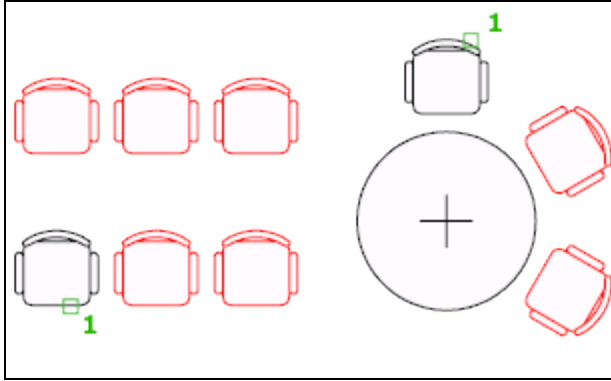

The Array dialog box is displayed. You can create rectangular or polar arrays by choosing the appropriate option. Each object in an array can be manipulated independently. If you select multiple objects, the objects are treated as one item to be copied and arrayed.

**MOVE:** 

Moves objects a specified distance in a specified direction.

Use coordinates, grid snaps, object snaps, and other tools to move objects with precision.

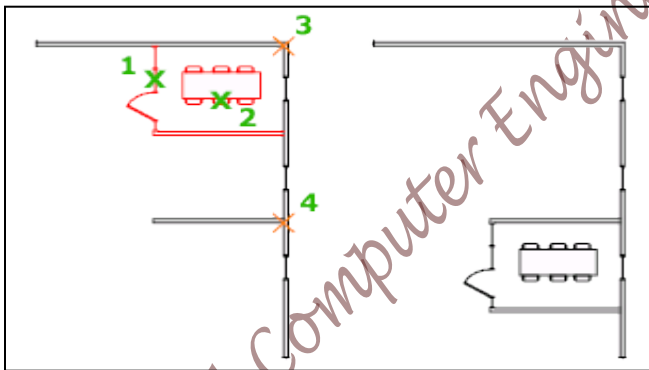

**ROTATE:** 

Rotates objects around a base point.

You can rotate selected objects around a base point to an absolute angle.

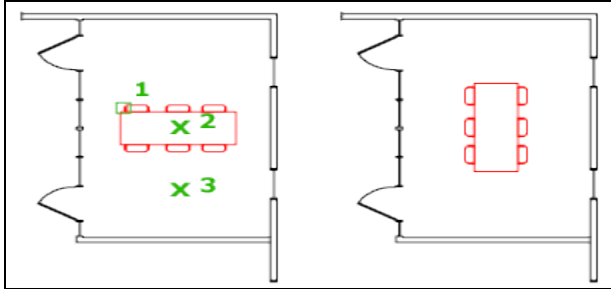

11.2015



Enlarges or reduces selected objects, keeping the proportions of the object the same after scaling.

To scale an object, specify a base point and a scale factor. The base point acts as the center of the scaling operation and remains stationary. A scale factor greater than 1 enlarges the object. A scale factor between 0 and 1 shrinks the object.

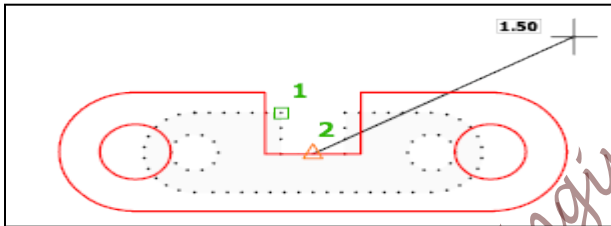

Trims objects to meet the edges of other objects.

To trim objects, select the boundaries. Then press Enter and select the objects that you want to trim. To use all objects as boundaries, press Enter at the first Select Objects prompt.

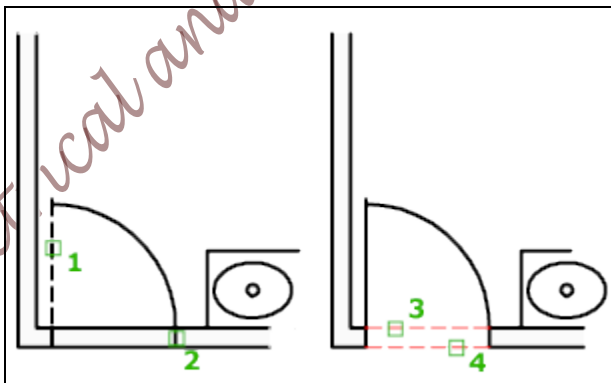

## To change the size for the dimensions:

1. Go to the Annotate from the main menu, then go to the Dimensions, then to the arrow as shown in red square.

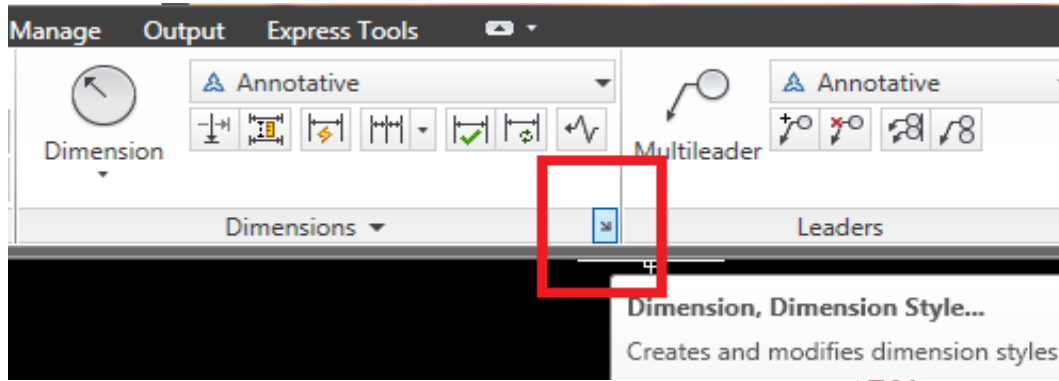

as in the following figure

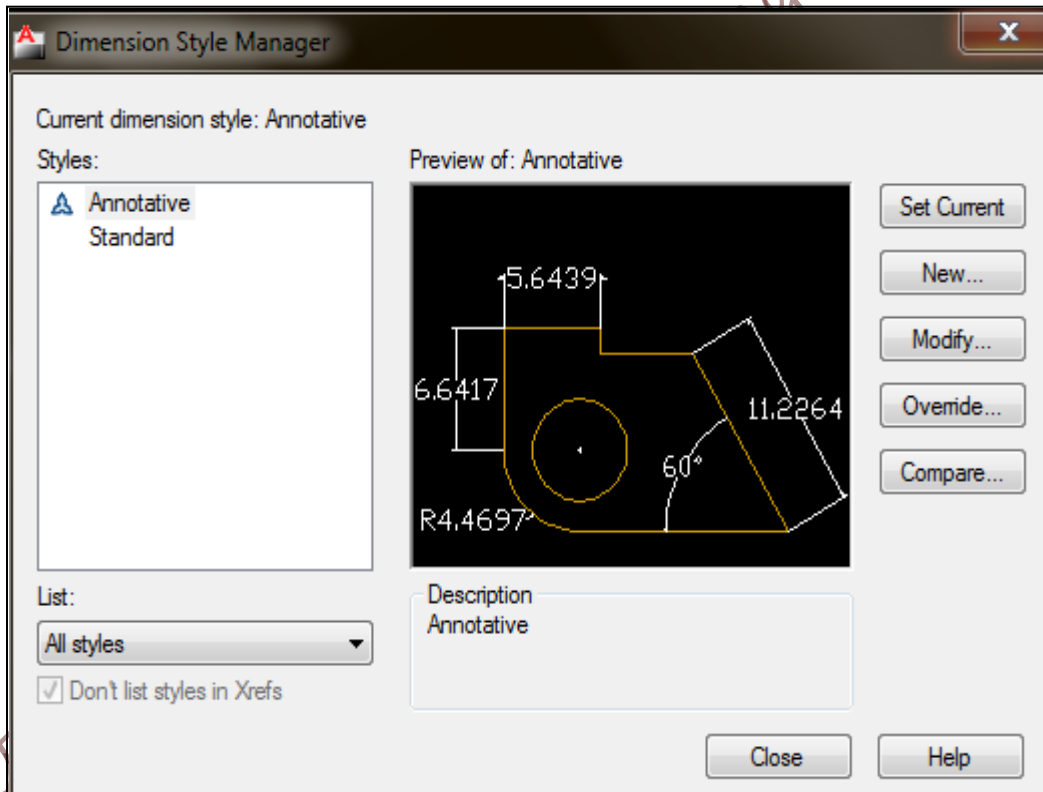

2. Go to modify as shown in the following figure

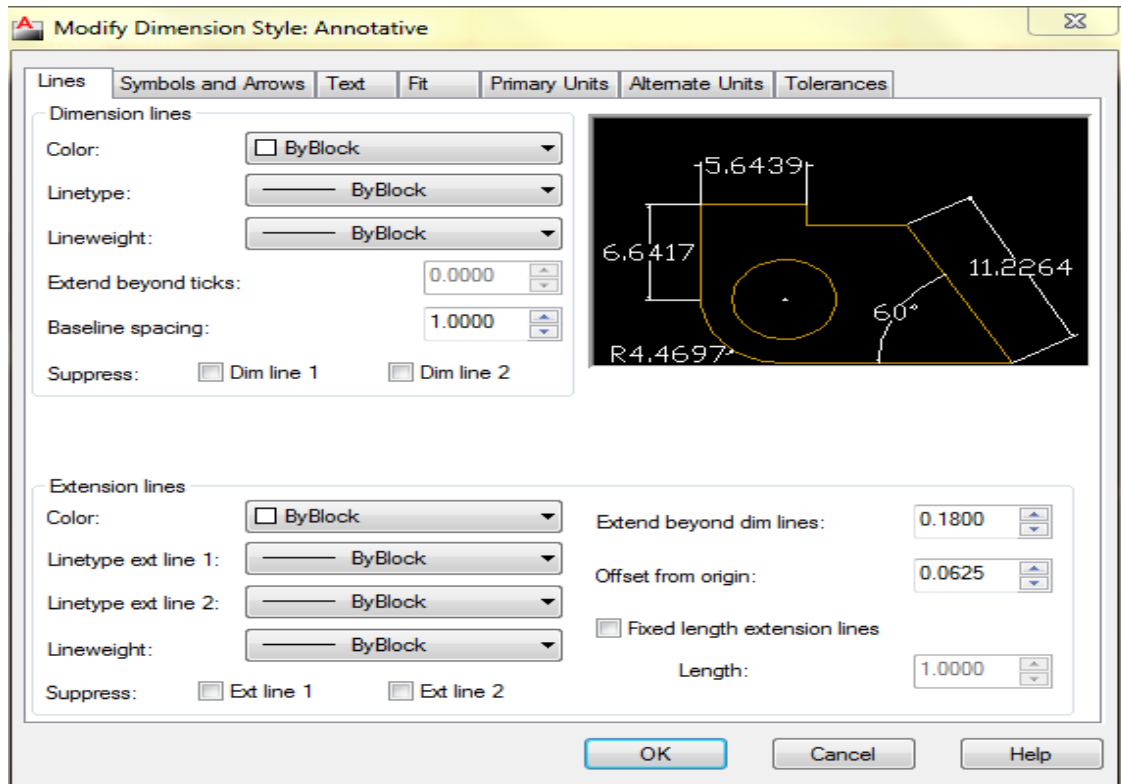

ZU, 2015

3. Then go to text as shown in the following figure

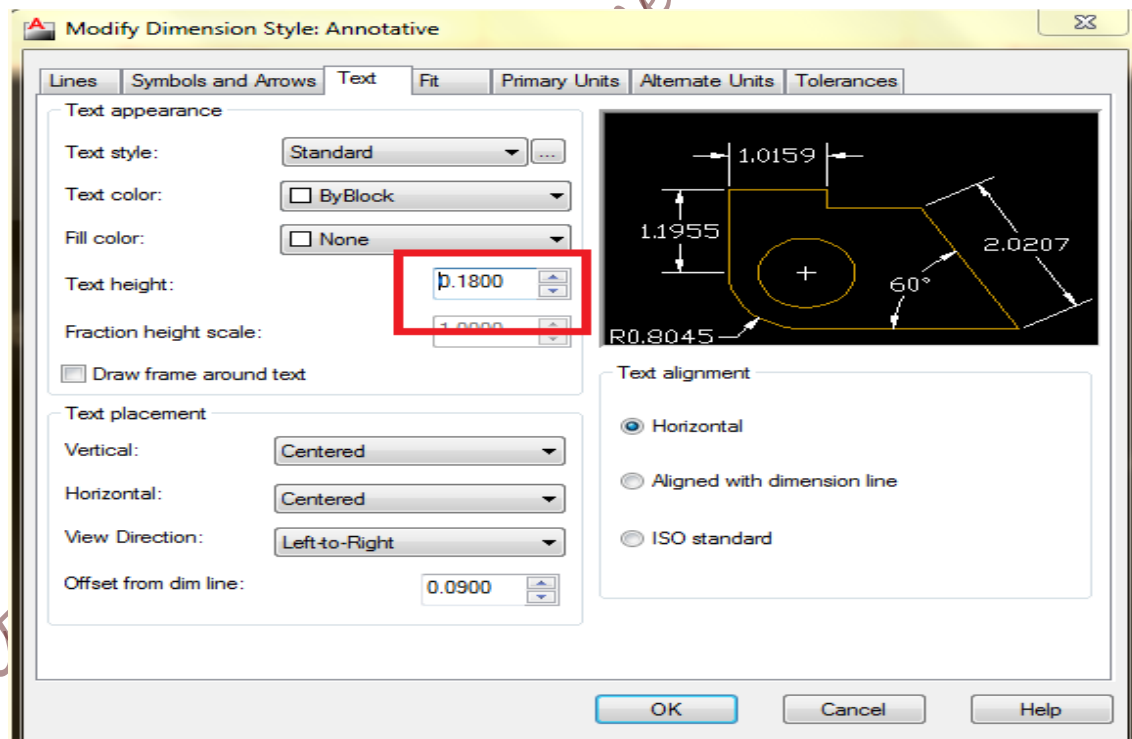

Elect

4. Change the text height from 0.18 to 1 or to any size suitable with your drawing.
5. Then ok.

## Experiment # 2

### Electrical Symbols

#### ➤ **Objectives:**

In this experiment we will learn to draw

1. Single-Diagram
2. Current Flow Diagram
3. Assembled-Diagram (wiring diagram)
4. Table of symbols used in electrical wiring and learn how to draw them.

#### ➤ **Introduction:**

Electrical symbols are small pictures or images (also known as pictograms) which you may see in a wide variety of places. If you've ever worked on building electronic devices of your own (using circuit boards for example) then you will need to know which component to use in your project. Usually, when you try to interpret a circuit diagram, all of the electrical symbols will have their own images. Electrical symbols and electronic circuit symbols are used for drawing schematic diagrams.

#### **Single-Diagram**







A simplified notation for representing a three-phase power system. The one-line diagram has its largest application in power flow studies. Electrical elements such as circuit breakers, transformers, capacitors, bus bars, and conductors are shown by standardized schematic symbols.

#### ➤ **Procedure:**

#### ➤ **Electrical Symbols:**

In this part you must see all electrical symbols, and know how to draw every element.

On\Off One Way Switch	مفتاح مفرد	
Two Circuit Switch (Double switch)	مفتاح مزدوج	
Two Way Switch	مفتاح درج (فكسل)	
Cross Switch	مفتاح صليب	
Double Pole Switch With Indicator Lamp	مفتاح قطع ثنائي القطبية مع لمبة اشارة	
Push Button	ضاغط	
Ceiling Lighting Point	نقطة اناارة سقفية	
Ceiling Lighting Point Water proof	نقطة اناارة سقفية ضد الماء	
Side Lamp	نقطة اناارة جانبية	
Pendant Lighting Point	نقطة اناارة سقفية ثريا	
Power socket-single phase	مخرج كهرباء 16 امبير	
Power socket-Water Proof	مخرج كهرباء 16 امبير ضد الماء	
Telephone Outlet	مخرج تلفون	
Television Outlet	مخرج تلفزيون	
Satellite Outlet	مخرج ستلايت	
Intercom Outlet	مخرج انتركم	
Main Distribution Board + ELV	لوحة كهرباء رئيسية مع جهد منخفض	
Sub Distribution Board	لوحة كهرباء فرعية	
Extra Low Voltage Box (ELV)	علبة الجهد المنخفض	

Earth Leakage C. B .	قاطع تسريب ارضي	
C. B 10 , 16 , 20 , 25 A	مفتاح نصف اتوماتيك	
1*36 watt Fluorescent	لامبة فلورسنت 1*36 واط	
2*36 watt Fluorescent	لامبة فلورسنت 2*36 واط	
2*36 watt with Reflector	لامبة فلورسنت 2*36 واط مع عاكس	
2*36 watt Fluorescent (w . p . )	لامبة فلورسنت 2*36 واط ضد الماء	
Timer, step relay, Impulse relay	مؤقت درج	
Dimmer	التحكم بشدة الاضاءة	

1. Open the program from the start menu, then select AutoCAD from Autodesk, or by selecting it from the short cut on the disk top.
2. Create a new file :  
File >>> New, then the following figure will appear

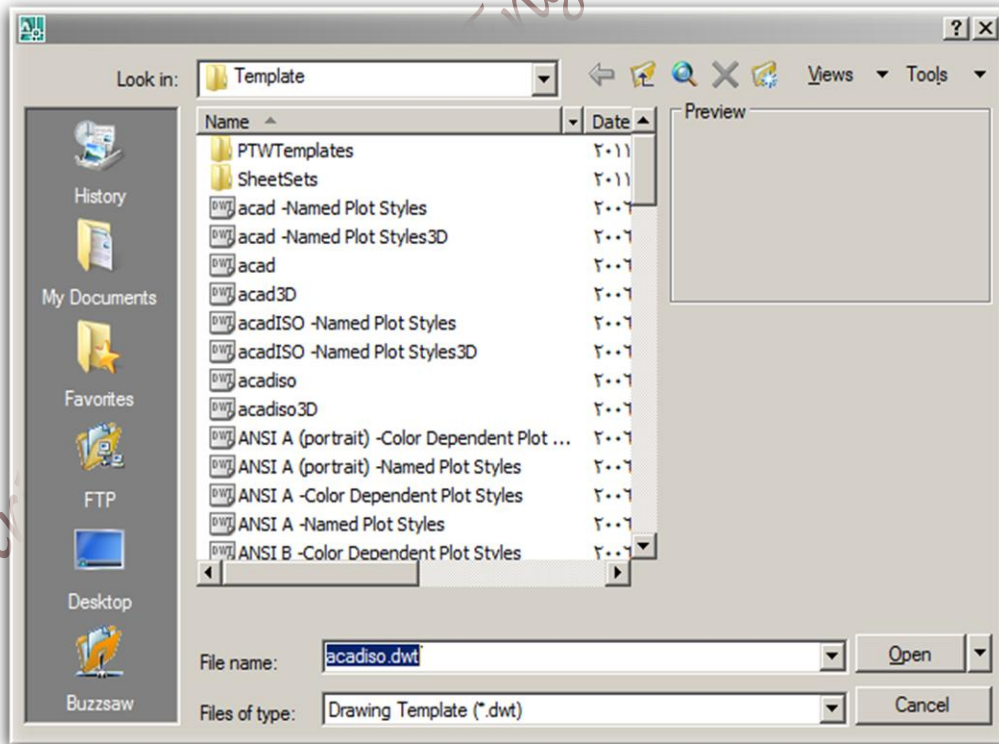

You must choose the file name, which is a default file name in AutoCAD.

**acadiso.dwt**

Files of type:

**Drawing Template (\*.dwt)**

Which means that we will use the metric system / global

**Note:**

Before you start a drawing, you must first decide what drawing units to use. In AutoCAD, distances are measured in drawing units. In a drawing, one drawing unit may equal one inch, one millimeter, one meter, or one mile. Before you begin drawing, you decide what one drawing unit will represent. AutoCAD does not include a setting that determines the length of a drawing unit.

➤ **Draw one way switch single pole, one gang, two gang, three gang:**

1. Draw circle with a radius 5.09, then from the center of the circle draw line as in the following Figure 2.1 with length 6.19, angle =69°, then complete the drawing of three gang switch.

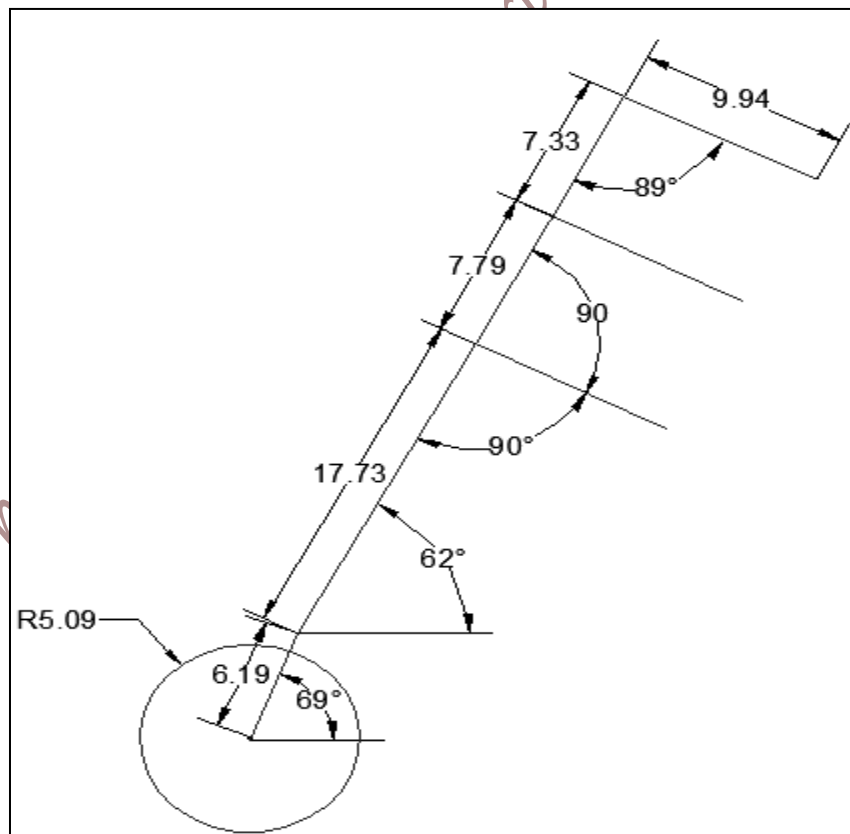
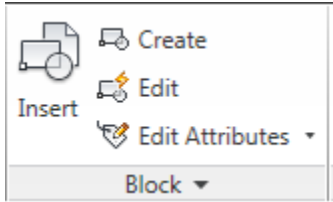

Figure 2.1 one way switch single pole, three gang



2. To use your drawing as block, select your drawing then On the ribbon, click Home tab ➤ Block panel ➤ Create.



The following window will appear

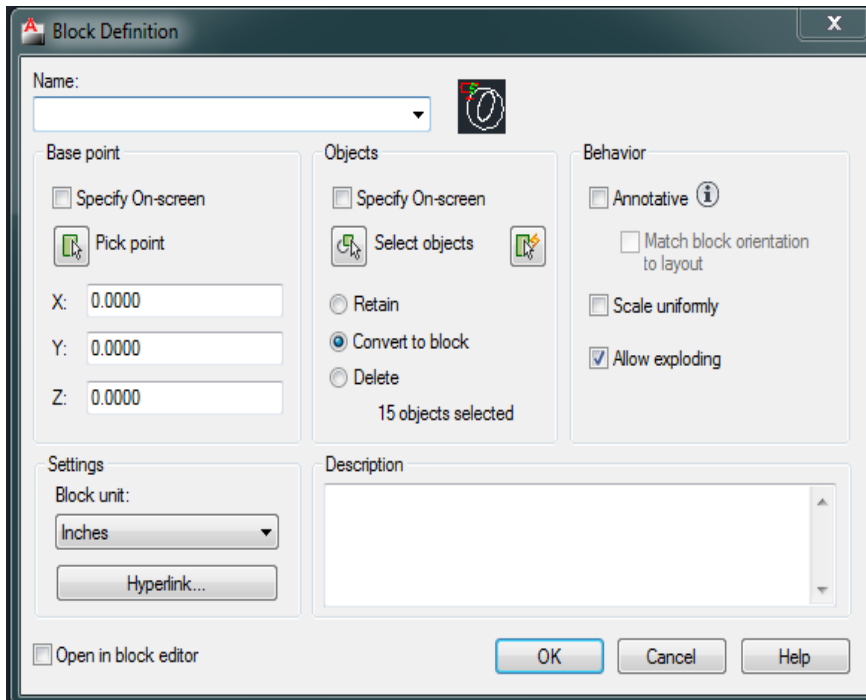

3. First you must write the name of the block in the name field, then select allow exploding, and then choose the block unit as you need, then press ok when you finish your setting for the block.
4. Try to select any element in your drawing, you must see that all elements are used as one set.

➤ **Draw COMPACT FLUORESCENT SURFACE MOUNTED GLOBE:**

1. First draw circle with radius = 12.9551, next draw the second circle with radius =19.5057, then complete the drawing .

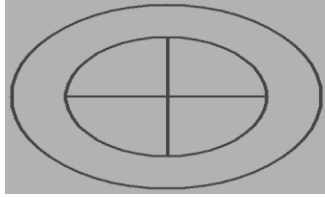

5. Change your drawing to Block.



6. Click  > Open > Electrical Symbols.dwg, you will find the most used elements for installation drawings.

7. Try to use these elements in the next part.

➤ **Draw cross switch:** 

Cross switch has two ways when it works, as shown in the following figures.

1. Draw the two states of cross switch.

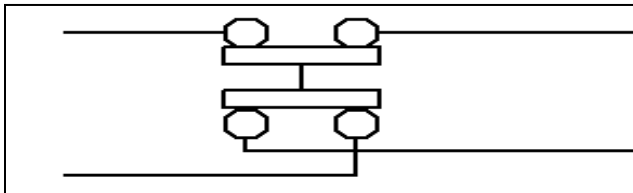

State 1

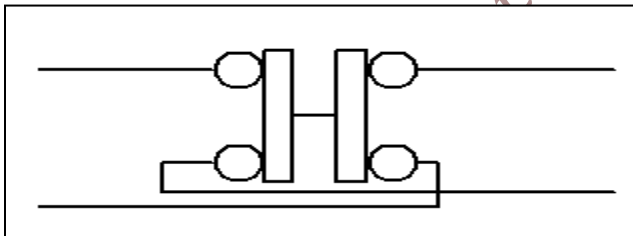

State 2

➤ **Create layers for This Experiment:**

Create three layers as following as in Table 2.1

Table 2.1: The Layers for this experiment

Name	Color	Lineweight	Linetype
Elements	Green	0.4mm	Continuous
Dimension	Red	0.05mm	Continuous
Text	Blue	0.05mm	Continuous

**Note:**

For all parts in the experiment use the layers as in the Table 2.1

➤ **Controlling number of lamps by several switches:**

In the circuit of Figure 2.2, LAMP1 and LAMP2 are on or off depending on the state of SW1 and SW2

**-Single-Diagram of the circuit:**

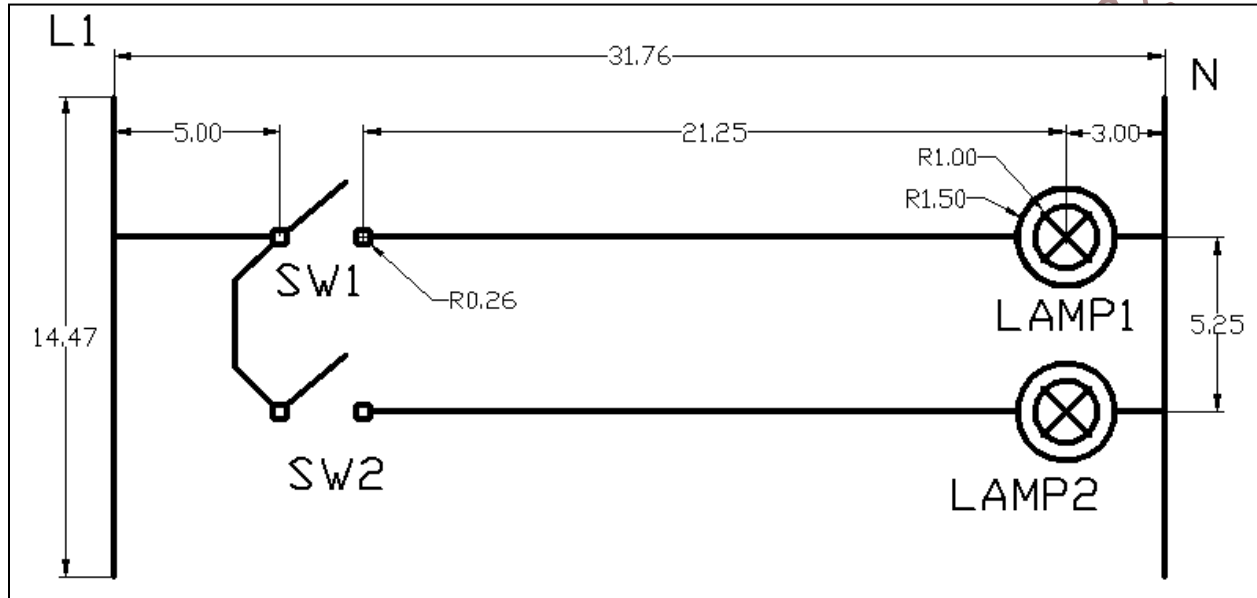



Figure 2.2 Controlling numbers of lamps by several switches

1. First Draw two vertical lines in parallel using object snap.
2. Then complete the total drawing, using the dimensions in the following figure.
3. Save your work >> Click  > Save as > your ID#.dwg

**Note:** You must save the changes in your drawing at every step by clicking  > save.

**-Current Flow Diagram of the circuit:**

The following circuit shown in Figure 2.3 shows the direction of current, and the number of lines through every tube.

4. Draw the following circuit as a Current Flow Diagram

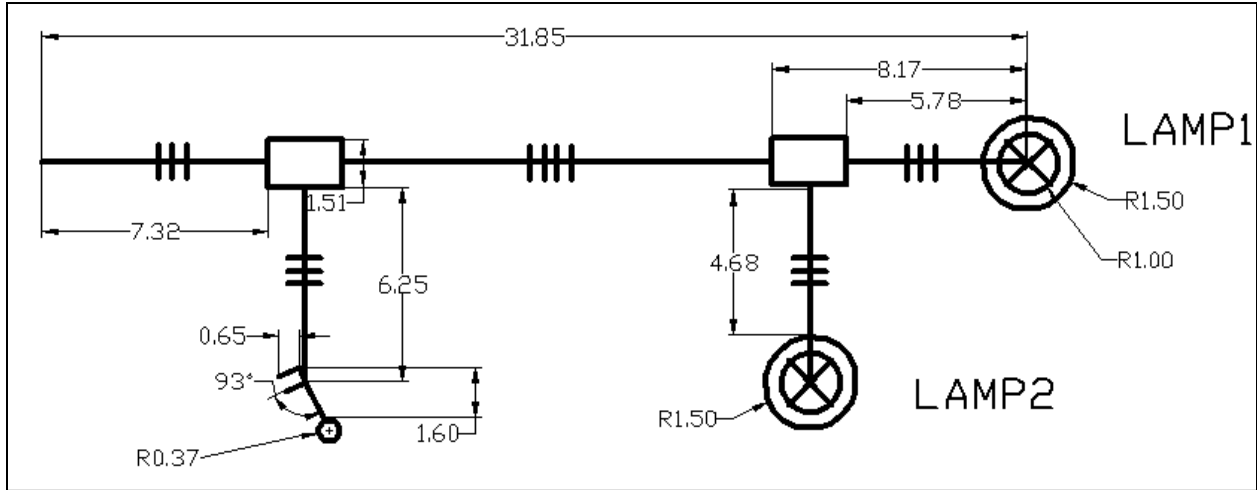

Figure 2.3 Current Flow Diagram

5. Save the changes in your drawing.

**- Assembled-Diagram:**

6. In the same sheet draw the circuit of Figure 2.4 which is the Assembled-Diagram of the circuit (wiring diagram).

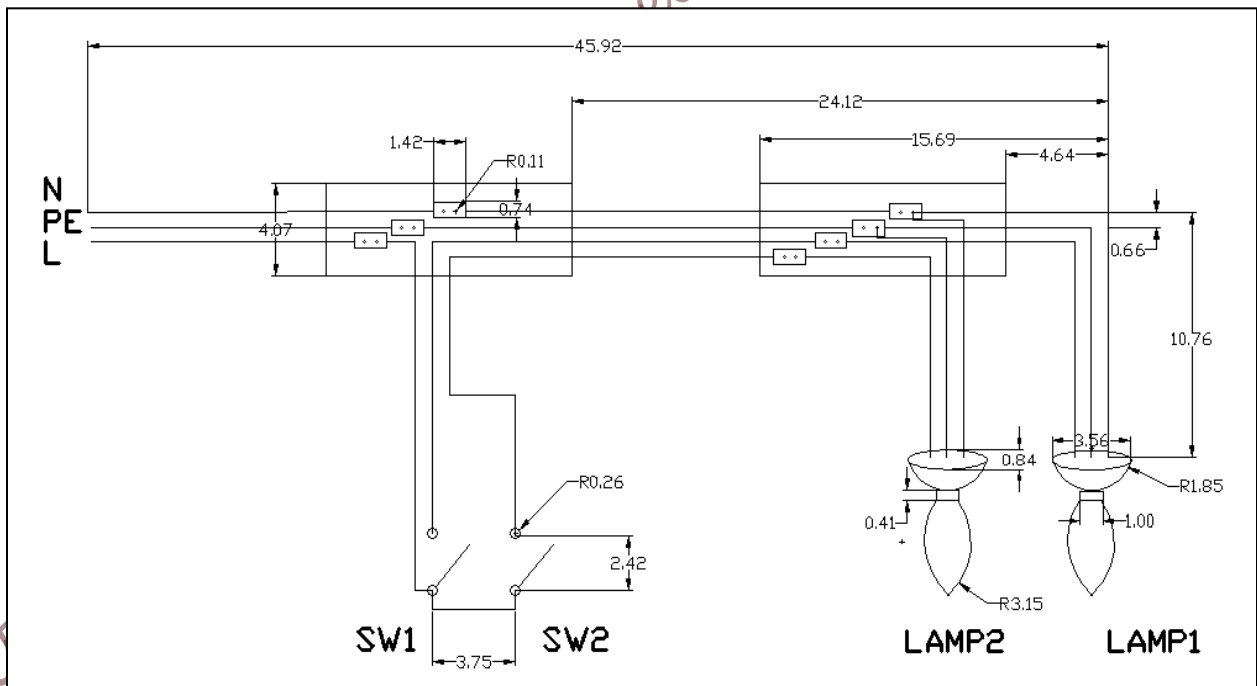

Figure 2.4 Assembled (Wiring)-Diagram

7. Save the changes in your drawing.

**-Exercise :**

Design another circuit to control more than two lamps as follows:

LAMP1 and LAMP2 on together, using one switch, then draw single-Diagram, current Flow Diagram, and assembled-Diagram.(wiring diagram)

➤ **Lamp lighting controlled from two places, using a pair of two-way switches:**

In this circuit, LAMP1 is on or off depending on the state of SW1, and SW2, where SW1, and SW2 are located in two different places.

**-Single-Diagram:**

1. Create a new file: File >>> New.
2. Draw the circuit as shown in Figure 2.5.

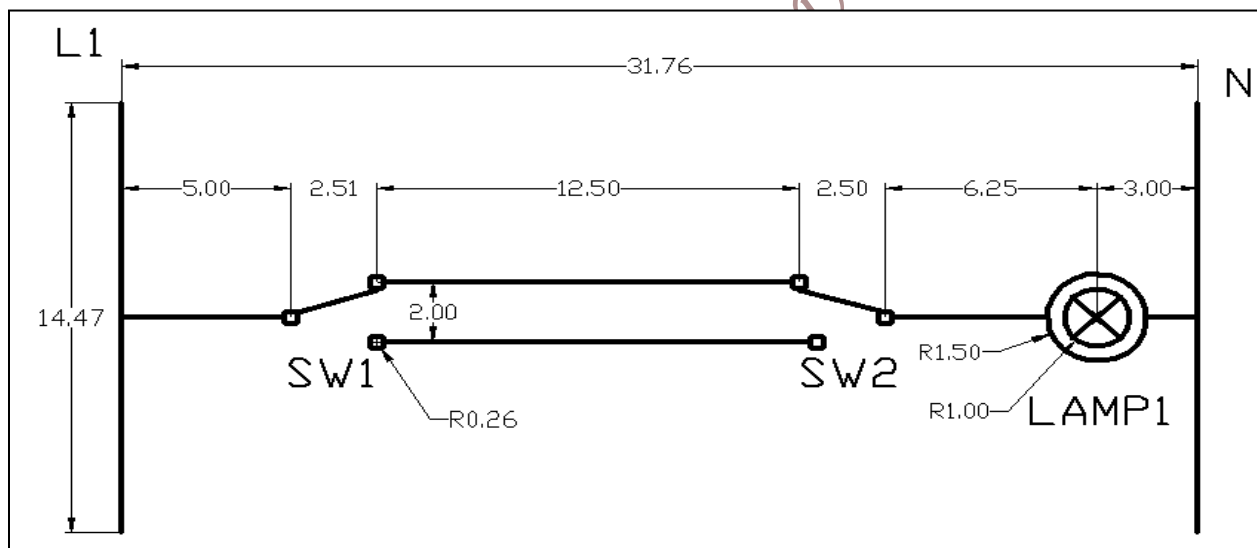

Figure 2.5 Lamp lighting is controlled from two places, using Two way switches

3. Save the changes in your drawing.

**-Current Flow Diagram:**

4. In the same sheet draw the circuit in Figure 2.6, which is the Current Flow Diagram of the circuit.

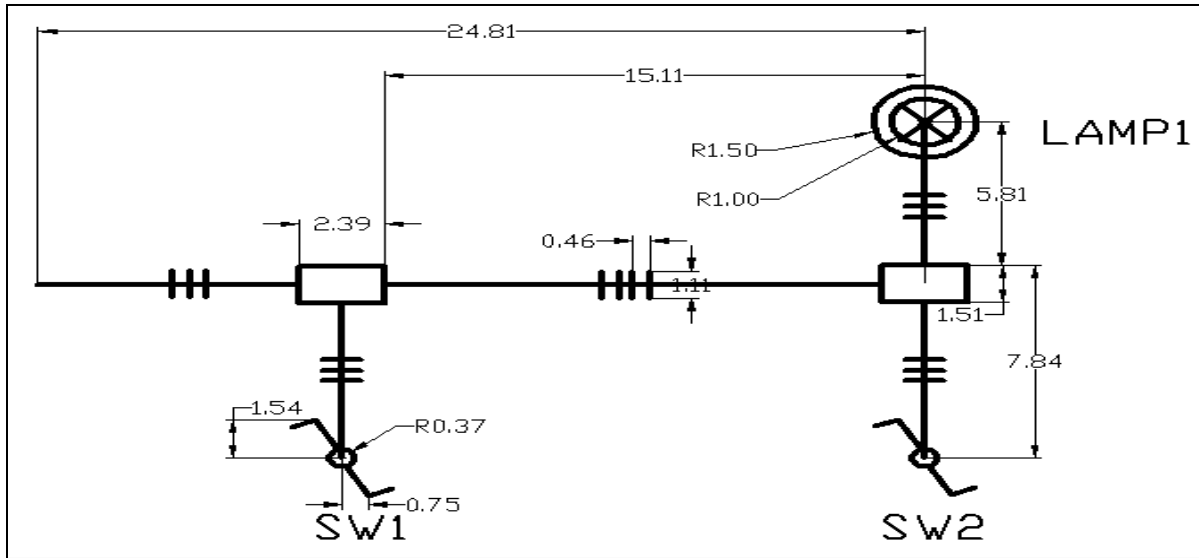

Figure 2.6 Current Flow Diagram of Lamp lighting circuit

5. Save the changes in your drawing.

**- Assembled-Diagram:**

6. In the same sheet draw the circuit in Figure 2.7 which is the Current Flow Diagram of the pervious circuit.

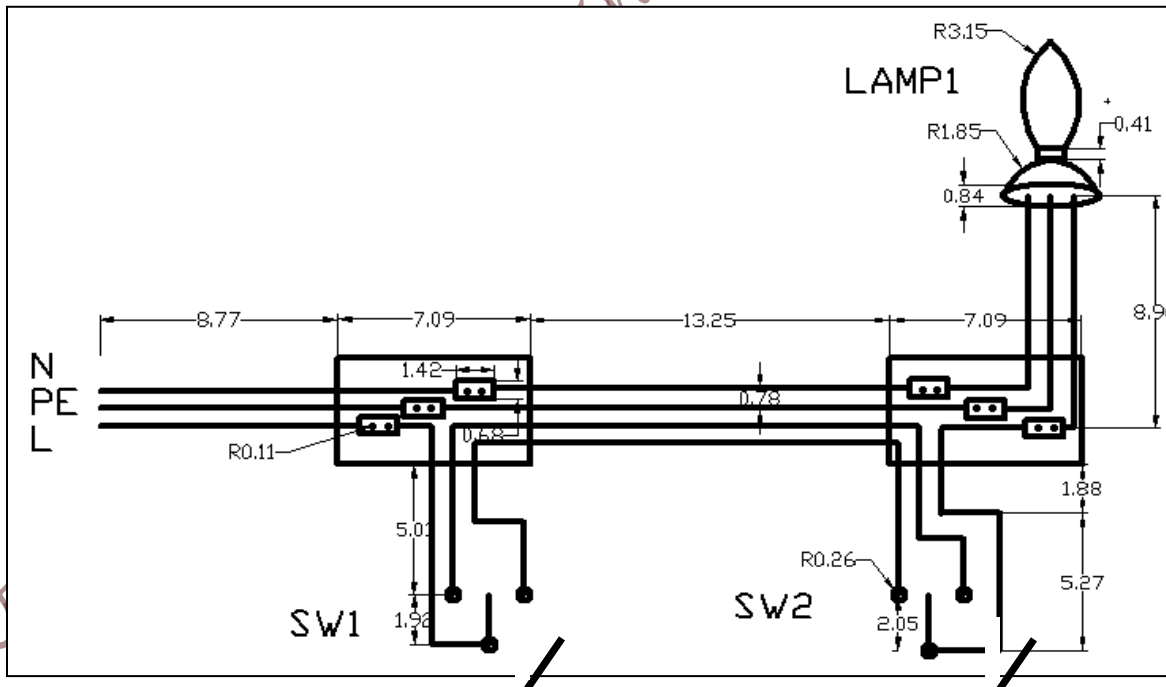

Figure 2.7 The Assembled (Wiring)-Diagram of Lamp lighting circuit

7. Save the changes in your drawing.

➤ **Lamp lighting is controlled from more than three locations by adding Cross switches between the two way switches at either ends:**

In this circuit, lamp1 is controlled from three different location, depending on the state of each switch. Note that SW1, and SW2 are two way switches, while SW3 is a cross switch.

**-Single-Diagram:**

1. Create a new file: File >>> New.

Draw the circuit as shown in Figure 2.8.

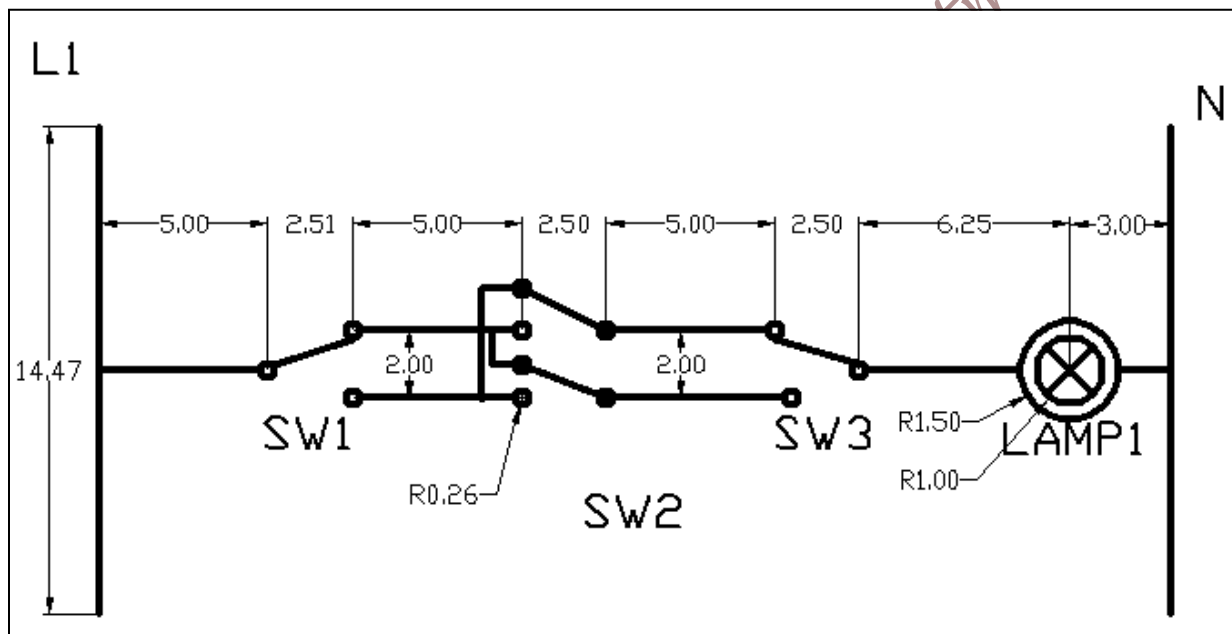

Figure 2.8: Lamp lighting is controlled from three locations

2. Save the changes in your drawing.

**-Current Flow Diagram:**

In the same sheet draw the circuit of Figure 2.9, which is the Current Flow Diagram

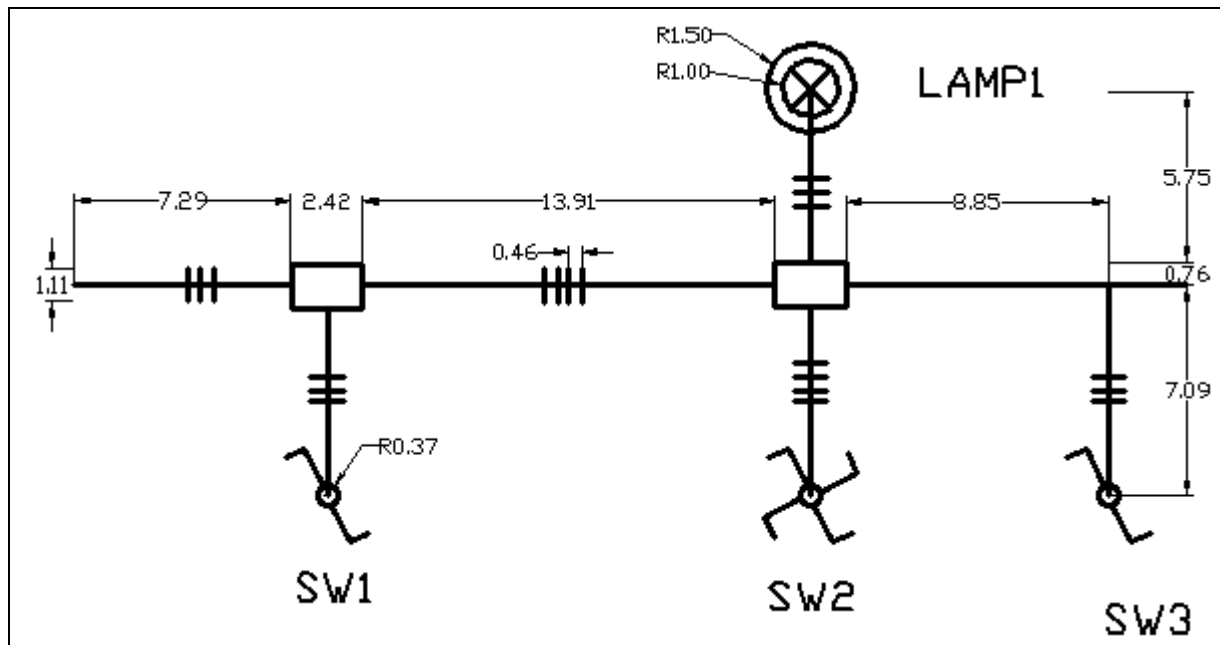

Figure 2.9: Current Flow Diagram of Lamp lighting controlled from three locations

3. Save the changes in your drawing.

**- Assembled-Diagram:**

In the same sheet, draw the circuit of Figure 2.10 which is the wiring Diagram.

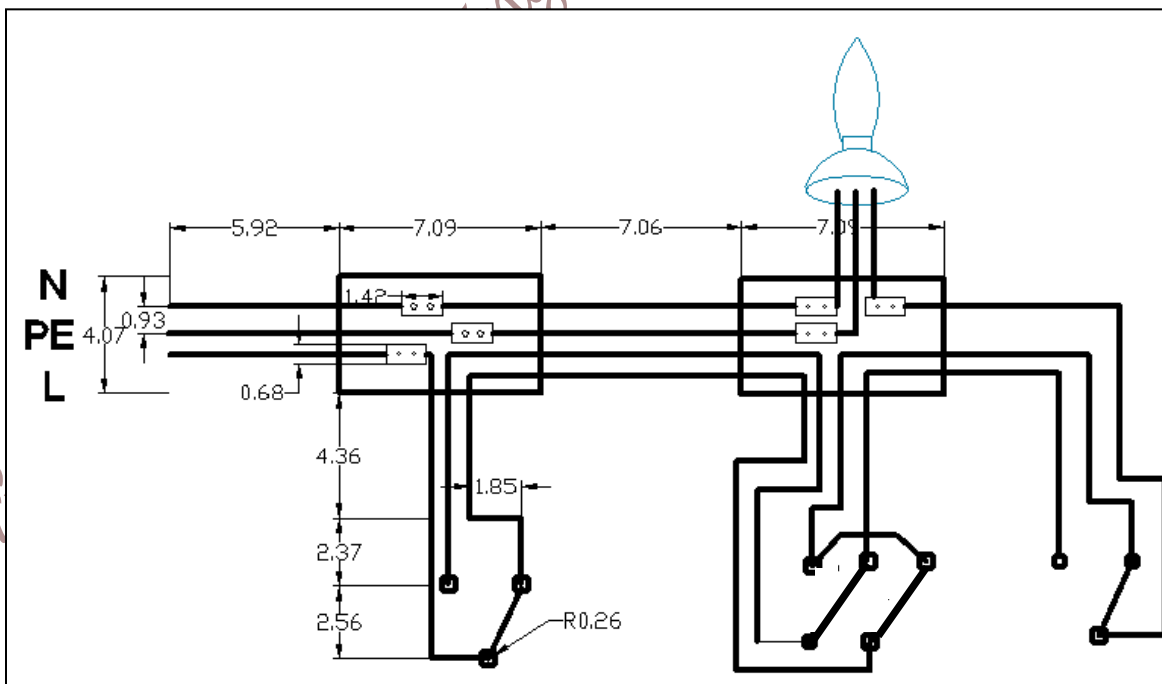

Figure 2.10: Assembled (Wiring)-Diagram Lamp lighting controlled from three locations

4. Save the changes in your drawing.



➤ **Lighting Stir case by Timer or step Relay (Impulse relay):**

**-Single-Diagram:**

1. Create a new file: File >>> New.
2. Draw the circuit of figure 2.11.
3. Save the changes in your drawing.

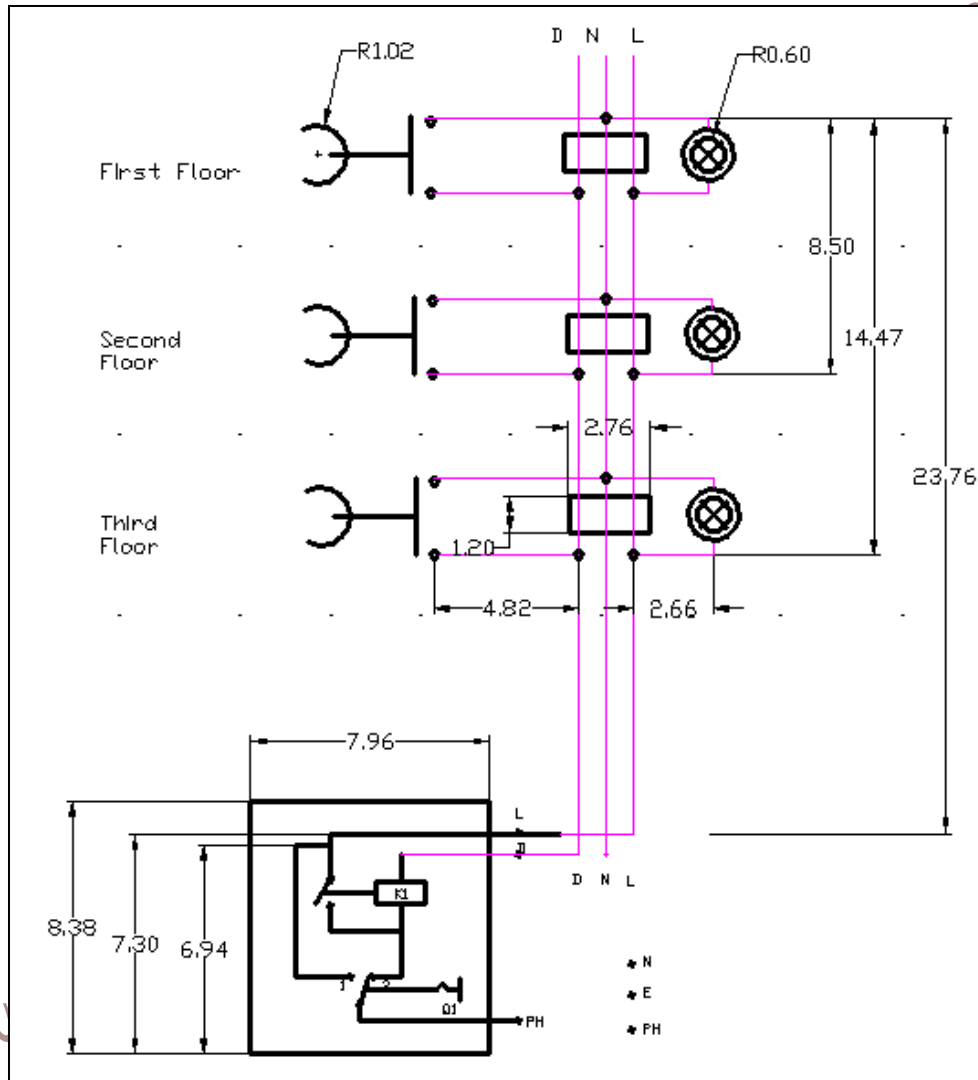

Figure 2.11: Light controlled by a timer

➤ **Exercise:**

Draw the Current Flow Diagram of the pervious circuit, and Assembled-Diagram.

*Electrical and Computer Engineering Department-BZU, 2015*

## Experiment # 3

### Single Phase Electrical Drawings

#### ➤ **Objectives:**

In this experiment we will learn how to draw the flowing plans for a given house

1. Lighting Plan
2. Power Plan
3. Extra Low Voltage Plan
4. Power, Rizer Diagram, and Distribution Board.
5. Earthing system.

#### ➤ **Introduction:**

An electrical drawing is a type of technical drawing that shows information about power, lighting, and communication for an engineering or architectural project. Any electrical working drawing consists of "lines, symbols, dimensions, and notations to accurately convey engineering's design to electricians, who install the electrical system.

A House-Wiring-Diagram is essential to your home's wiring projects. Careful planning is essential for your safety, success of the project, and to ensure you have enough power with plenty to spare for future expansion.

Understanding basic-household-wiring is essential to tackle a wiring project safely. Knowing what each component function is, is a good place to start. Beginning with the power to your home, it will arriving from the power company either by overhead wires or by wires buried underground.

#### **Lighting Plan:**

Lighting is one of the important elements to create the framework and psychological health necessary to work, and good distribution of light that protects the eye from stress and prevents accidents and increases the person's ability to bid on work.

And often the lighting functions under the following classifications:

- General lighting: is that light up the place and check the light-General of the room.

- Lighting focused: that is to support and to give more direct light to the work and activity centers in the room.
- Lighting addressed: is used to highlight aesthetic points at home and draw attention to paintings or decorations final.

So distribution should be good sources of natural and artificial light in the house during the final stage of the house, illuminated either be a natural source of sunlight through the windows and openings, or industrial home lighting.

Many types of industrial home lighting:

- Dishes, lamps, flourcent lamps, side lamps
- Shutter or windows blinds
- Hanging lamps
- Chandeliers

#### **Earthing system plan:**

This plan is used to show, where the earth boxes and check boxes will insert in the home or the building. And also to show where the galvanized steel inserted in the building structure.

#### **Power Plan:**

This plan shows the distribution of the socket outlets, main distribution socket and cans assembly.

Also this plan shows where the water proof sockets are inserted, and the wires connected between the sockets.

#### **Extra Low Voltage Plan:**

Extra Low voltage wiring is the wiring for Audio, Video, Telephone, Intercom, Data, Alarm System, Weather Station, and generally any wiring for things using less than 50 volts. The Extra low voltage wiring is designed an installed that it could be easily reconfigured in the future.

#### **Power and Rizer Diagram:**

An electrical diagram (also known as a "one-line" diagram) is a drawing that shows how an electrical system is designed by diagramming how the different components are connected. It is the roadmap which electricians use as the directions to how the system is put together. This can be a simple diagram with only one electrical panel as you would find in a house. Or, it could contain several hundred distribution devices as you would find in a 30-storey hotel. Either way,

the electrical rizer diagram shows the sizes and locations of all transformers, panelboards, conductors, conduit, etc.

➤ **Notations:**

MDB	Main Distribution Board
DBG	Distribution Board for Ground Floor
ELV	Low Voltage
DBF	Distribution Board for First Floor
LDBG	Light Nodes in Distribution Board for Ground Floor
SDBG	Socket Nodes in Distribution Board for Ground Floor

➤ **Procedure:**

Click  ➤ Open ➤ Drawing3.dwg

Where this file contains a drawing of a house design.

➤ **Create the layers for This Experiment:**

Create three layers as following as in Table 3.1

Table 3.1: Layers or this experiment

Name	Color	Lineweight	Linetype
Light	Magenta	Default	Dashed
Power	Green	Default	Continuous
Low Voltage	Blue	Default	Continuous
Earthing	White	Default	Continuous

**Note:**

For all parts in the experiment use the layers as in the Table 3.1

➤ **PARTA: Lighting Plan :**

1. In the same file that's open make a copy of the design "drawing3\_light.dwg"
2. Make sure that you use the light layer.
3. Distribute the light element for Kitchen, Living room, Guest room, bathrooms, Bedrooms and Corridors as in Figure 3.1, and then draw your distribution in the copy of the design.
4. Save your work.

5. Distribute the switches for every room in the house, then draw your distribution in the design.
6. Distribute the LDBG Elements in the design, then draw your distribution in the design.
7. Save your work.
8. Make wire between the light element and the switches where used, then draw your distribution in the copy of the design.
9. Make sure that all lighting fixture and wirings in the same layer.
10. Save your work.

t-BZU, 2015

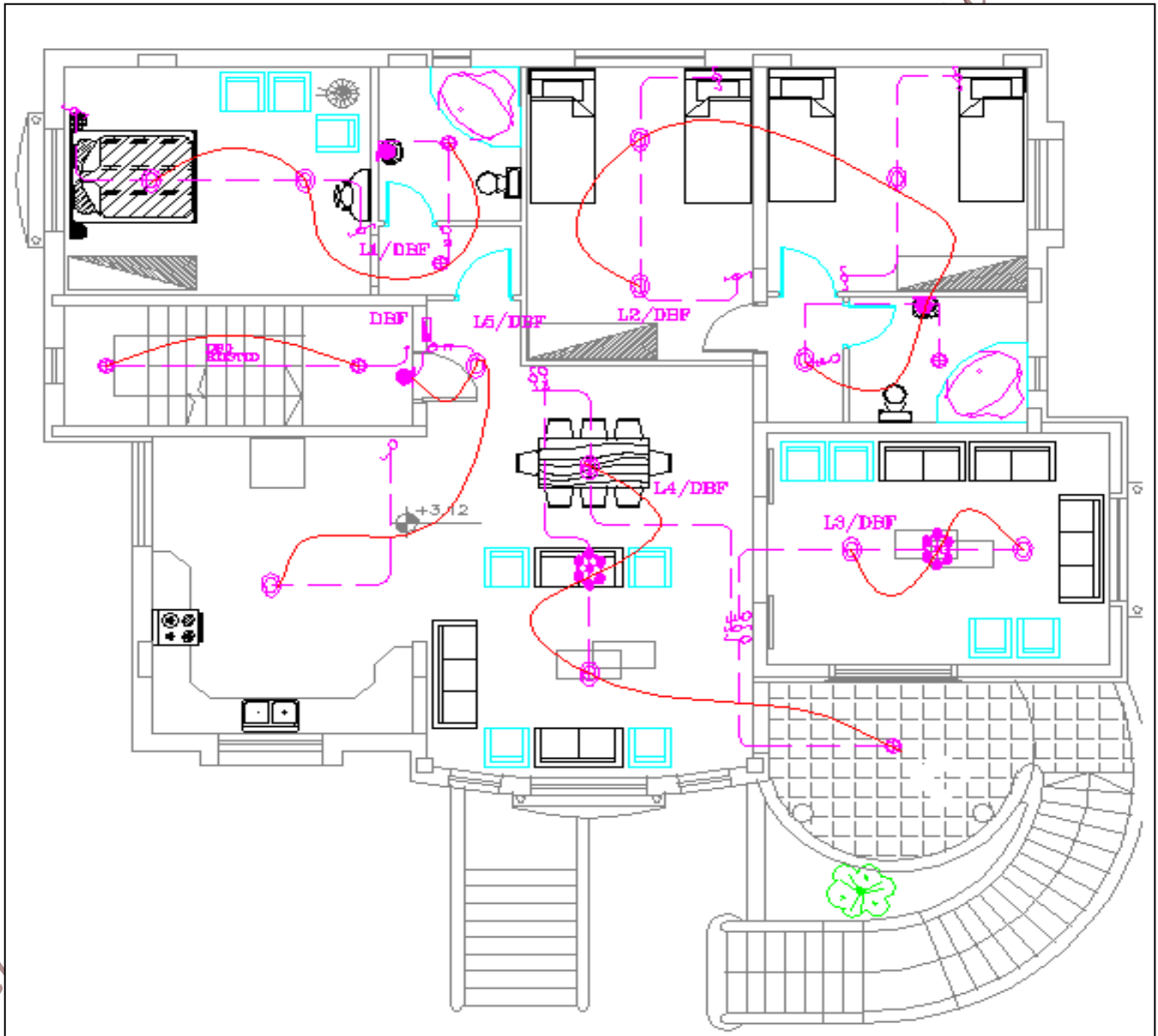

Figure 3.1 Lighting Plan of a house design

➤ **Note:**

All light elements not fixed, the designer can change the place and the type of element as using Florescent lamps as the house need.

➤ **PARTB: Power Plan:**

1. In the same file that's open make a copy of the design "drawing3\_ power.dwg"
2. Make sure that you use the power layer.
3. Distribute the socket outlet for Kitchen, Living room, Guest room, Bathrooms, Bedrooms and Corridors, as in Figure 3.2, then draw your distribution in the copy of the design.
4. Save your work.
5. Distribute the switches for socket outlets, where needed.
6. Distribute the SDBG Element in the design, then draw your distribution in the design.
7. Save your work.
8. Make wires between the socket outlets and the switches, where used, then draw your distribution in the design.
9. Save your work.

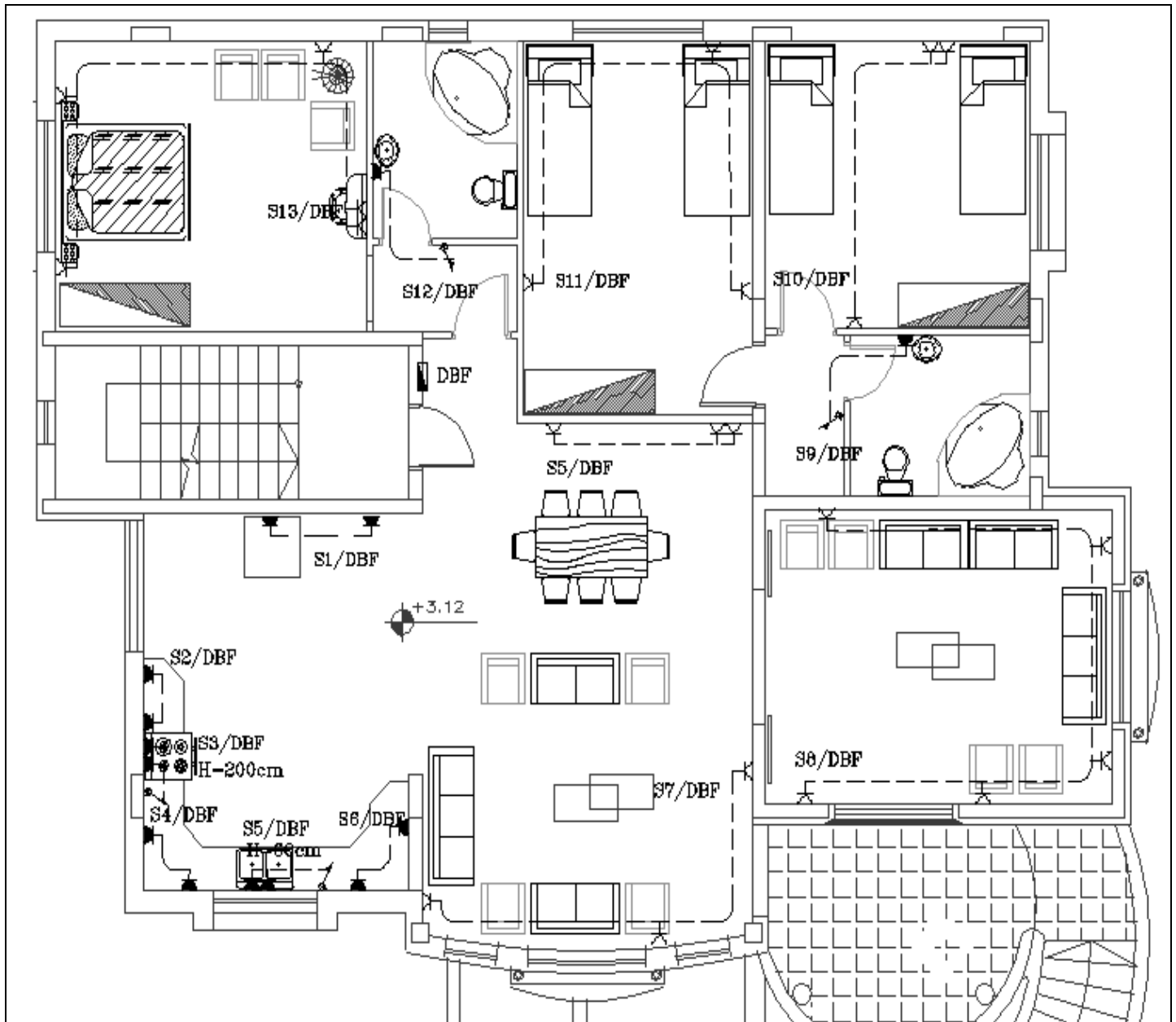

Figure 3.2 Power Plan of a house design

➤ **PARTC: Extra Low Voltage Plan:**

1. In the same file that's open make a copy of the design. "drawing3\_Extra lowvolt.dwg"
2. Distribute the audio, Video, Telephone, Intercom, Alarm System, for Kitchen, Living room, Guest room, and Bedrooms as in Figure 3.3, then draw your distribution in the copy of the design.
3. Save your work.



4. Distribute the DBG Element in the design, and then draw your distribution in the copy of the design.
5. Save your work.

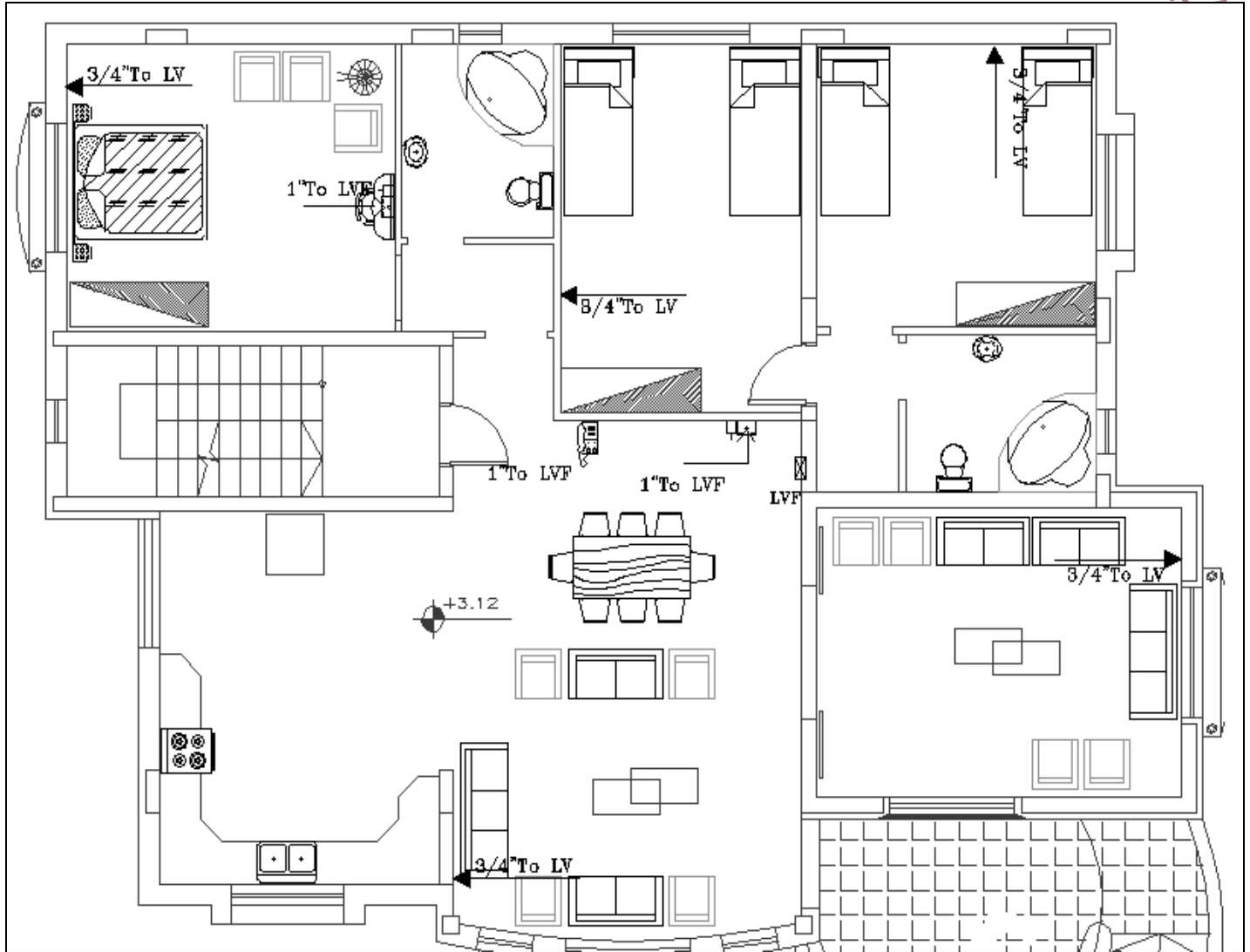

Figure 3.3 ELV Plan of a house design

➤ **PARTD: Earthing system:**

1. In the same file that's open make a copy of the design.
2. Draw the earthing system for the design.
3. Save your work

➤ **PARTE: Power and Rizer Diagram:**

In the same file draw the following diagram:

1. MDB Diagram.
2. DBG Diagram.
3. ELV- RIZER Diagram.
4. DB RIZER Diagram.
5. Main Earthing Bus Bar.
6. Save your work.

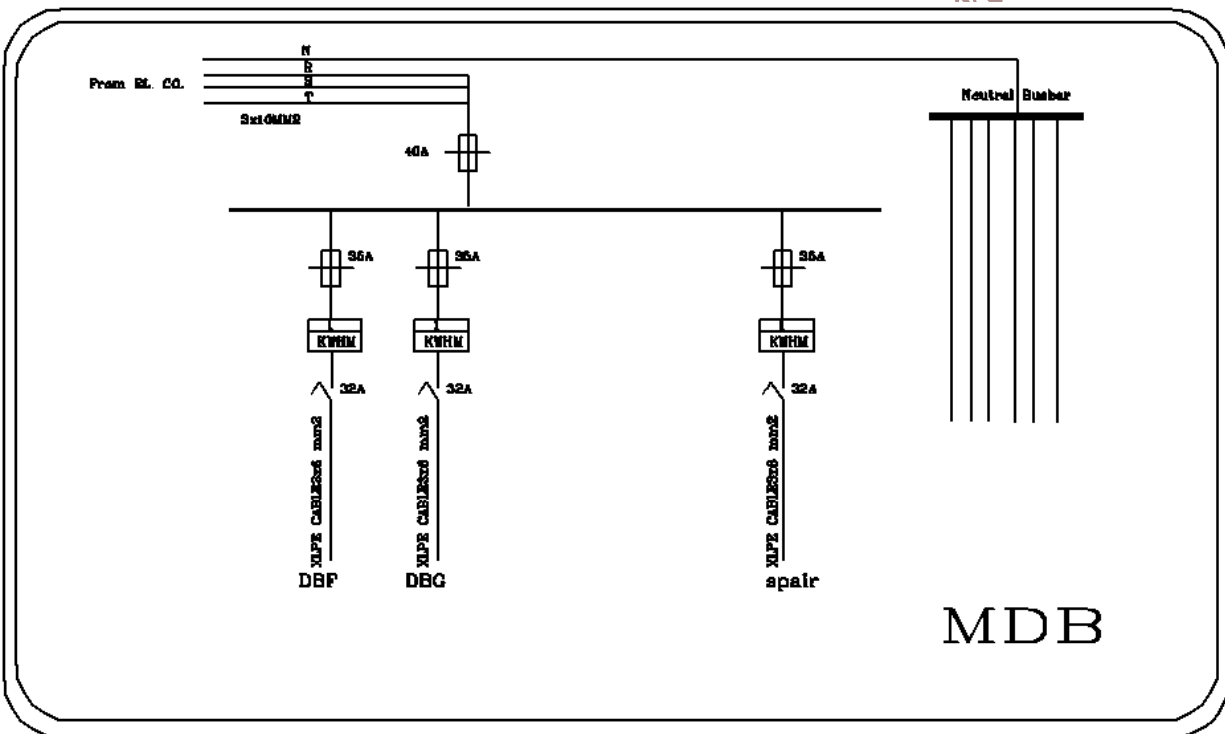

Figure 3.4: MDB Diagram

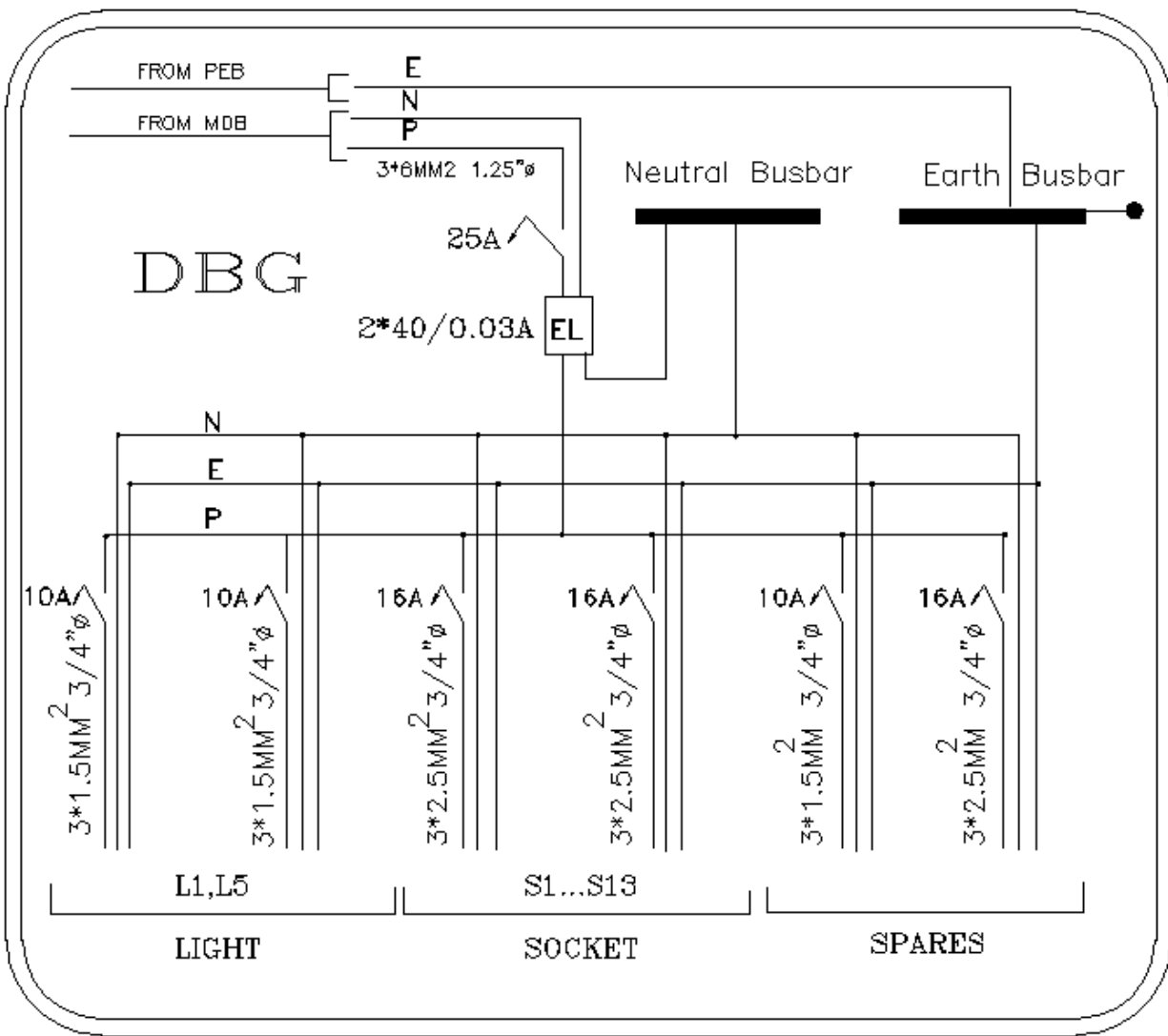
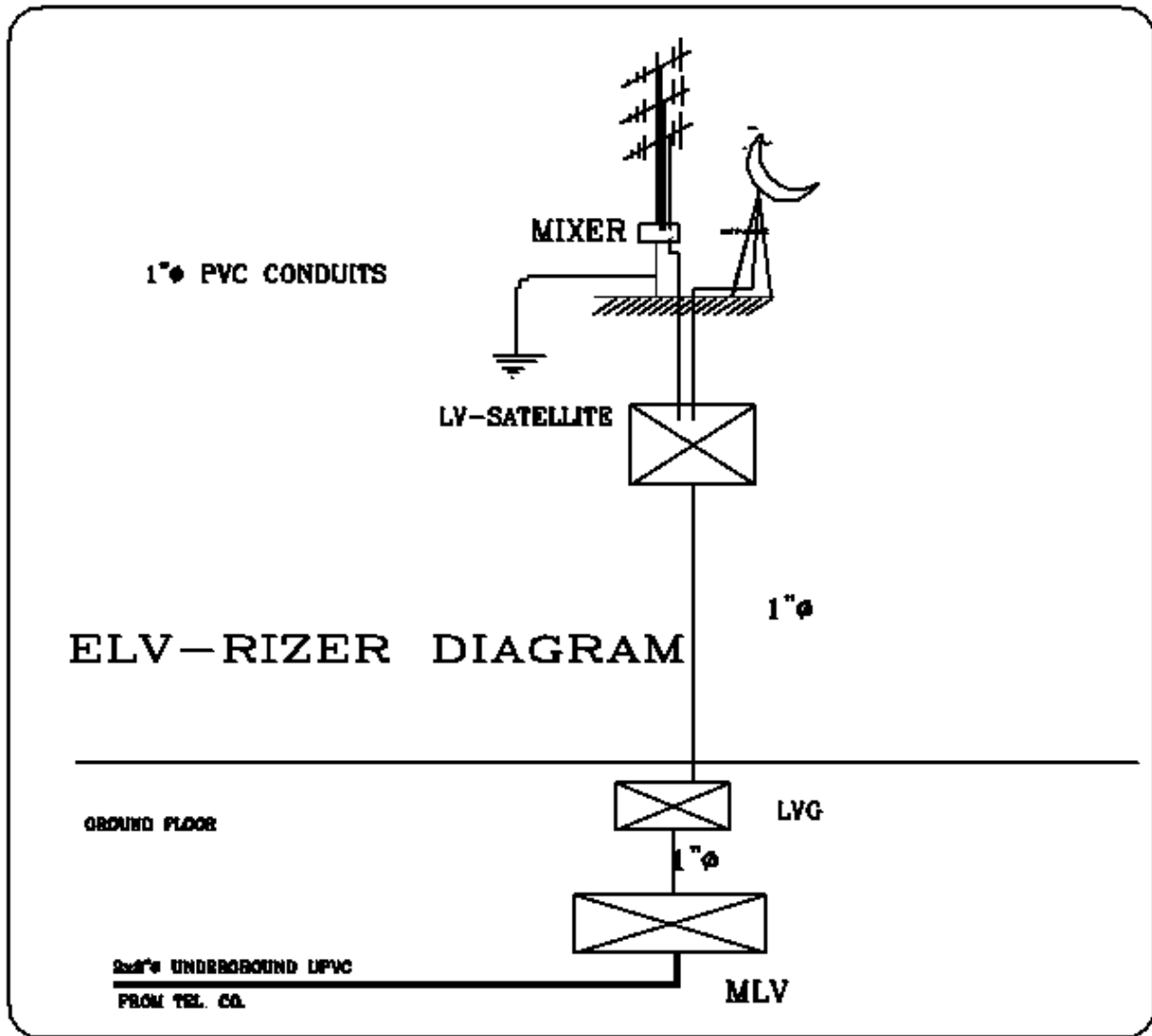

Figure 3.5: DBG Diagram



015

Electrical and Comp

Figure 3.6: ELV- RIZER Diagram

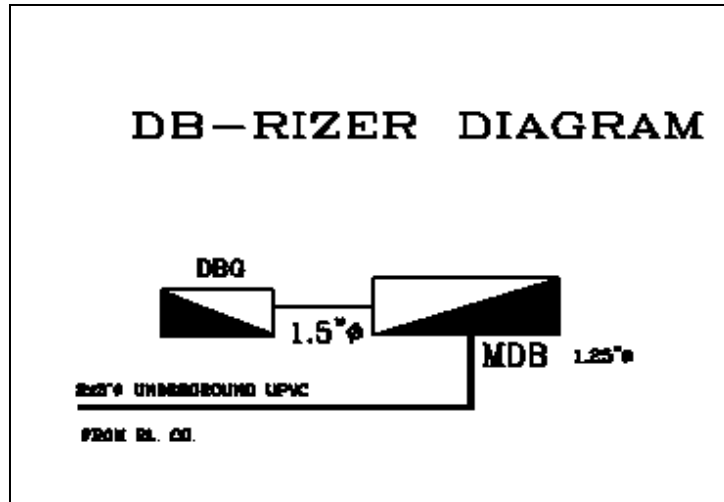

Figure 3.7: DB RIZER Diagram

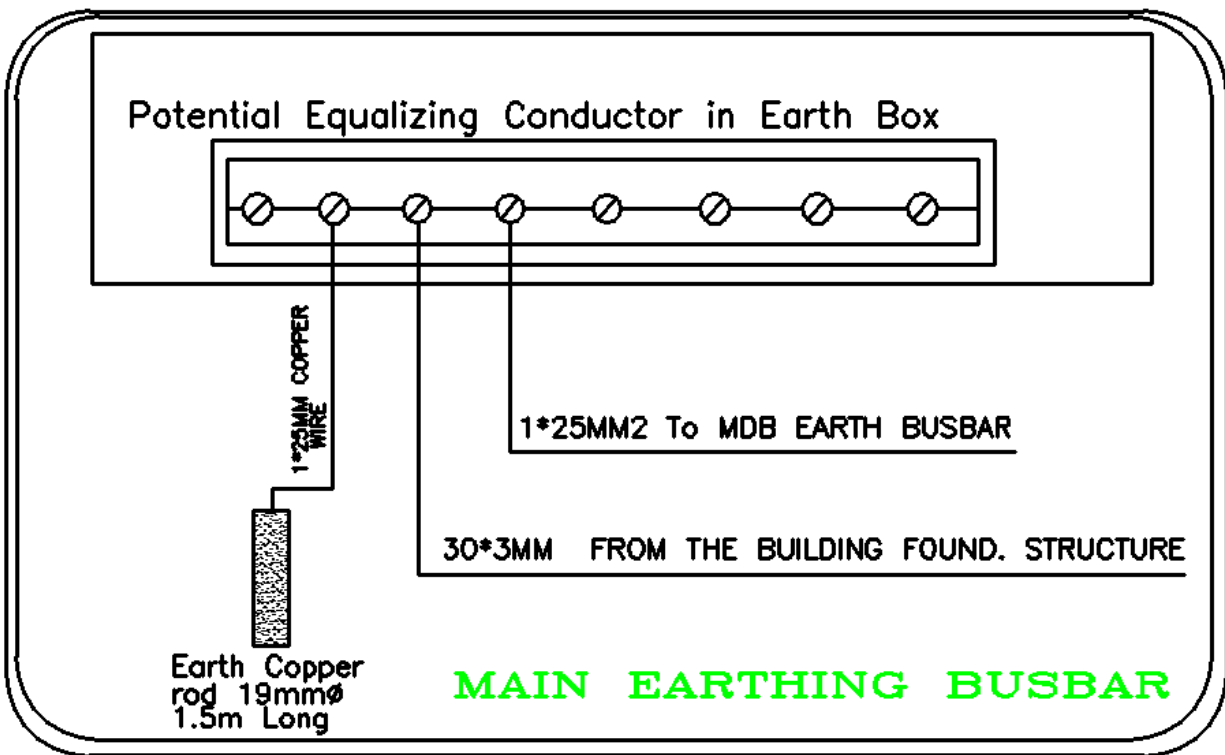

Figure 3.8: Main Earthing Bus Bar

*Electrical and Computer Engineering Department-BZU, 2015*

## Experiment # 4

### Single Phase Electrical Plan Design

#### ➤ **Objectives:**

In this experiment the flowing plan for electrical installations in a house will be designed and drawn.

1. Lighting Plan
2. Power Plan
3. ELV Plan
4. Power and Rizer Diagram
5. Earthing system

#### ➤ **Introduction:**

Most houses are supplied via a single-phase 220 Volt system with three wires. Depending on the power requirements of the house, the numbers of phases are specified. Even adding a spa tub to a single-phase supply can cause regular power tripping.

Due to the potentially lethal consequence of fire and electrical shock from poor wiring, all local authorities require electrical installation by a licensed contractor. That contractor is responsible for installing the local authority's meter box, the connections from the box to the house Distribution board and all wiring from that. Some electrical contractors are permitted to install other wiring, such as telephone, internet cable, security and intercom.

Owners should give the electrical contractor a copy of the working house drawings with all required light switches and power outlets, describing precise position (including heights) before the house structure is complete. There are standard symbols to represent the type of outlet. A design professional, will provide a detailed Electrical Diagram.

If some appliances such as stove, air-conditioners are to be hard wired (i.e. no switch), those appliances either need to be acquired in advance or their model numbers given to the electrical contractor.

The electrical installation occurs in two parts, followed by checking:

1. Rough in: As soon as the house structure is in place, and before walls are sealed, the electrician lays the wiring between the point of supply (DB) and the outlets according to the Electrical Diagram (leaving enough extra length for them to be pulled out for fixing the outlets.)
2. Fix out: When cladding is complete the outlets are fixed according to the owner's specifications, color and style. Owners should check that power points are installed as required, and are horizontal and centered.
3. Testing and checking by the local authority before occupancy.

There is often more than one tariff (cost per kilowatt hour) for domestic consumption, according to when electricity is used i.e. peak times or off peak. Electric water heaters usually heat during off peak times when the tariff is lower. In any location, there may also be a number of electricity suppliers with different tariff costs.

➤ **Prelab:**

Print the following house design as in Figure 4.1, and then prepare your design by hand on 4 papers for the following plane:

1. Lighting Plan
2. Power Plan
3. ELV Plan
4. Power and Rizer Diagram and Distribution Board

**Specification:**

1. Main bed room: One cross switch, 2 (Two-way switches), and 4 Power sockets.
2. Other bed room: 2 (Two way switches), and 3 Power sockets.
3. Kitchen: Two Circuit Switch, and 8-12 Power sockets.
4. Living Room: Three Circuit Switch, and 4 Power sockets.
5. Guest room: Three Circuit Switch, and 4 Power sockets.



6. Use Fluorescent Lamps, and side lamps for Bedrooms.
7. Corridors have two lighting fixtures and 2 two way switches
8. 2 power sockets in Corridors, one for backup charged light

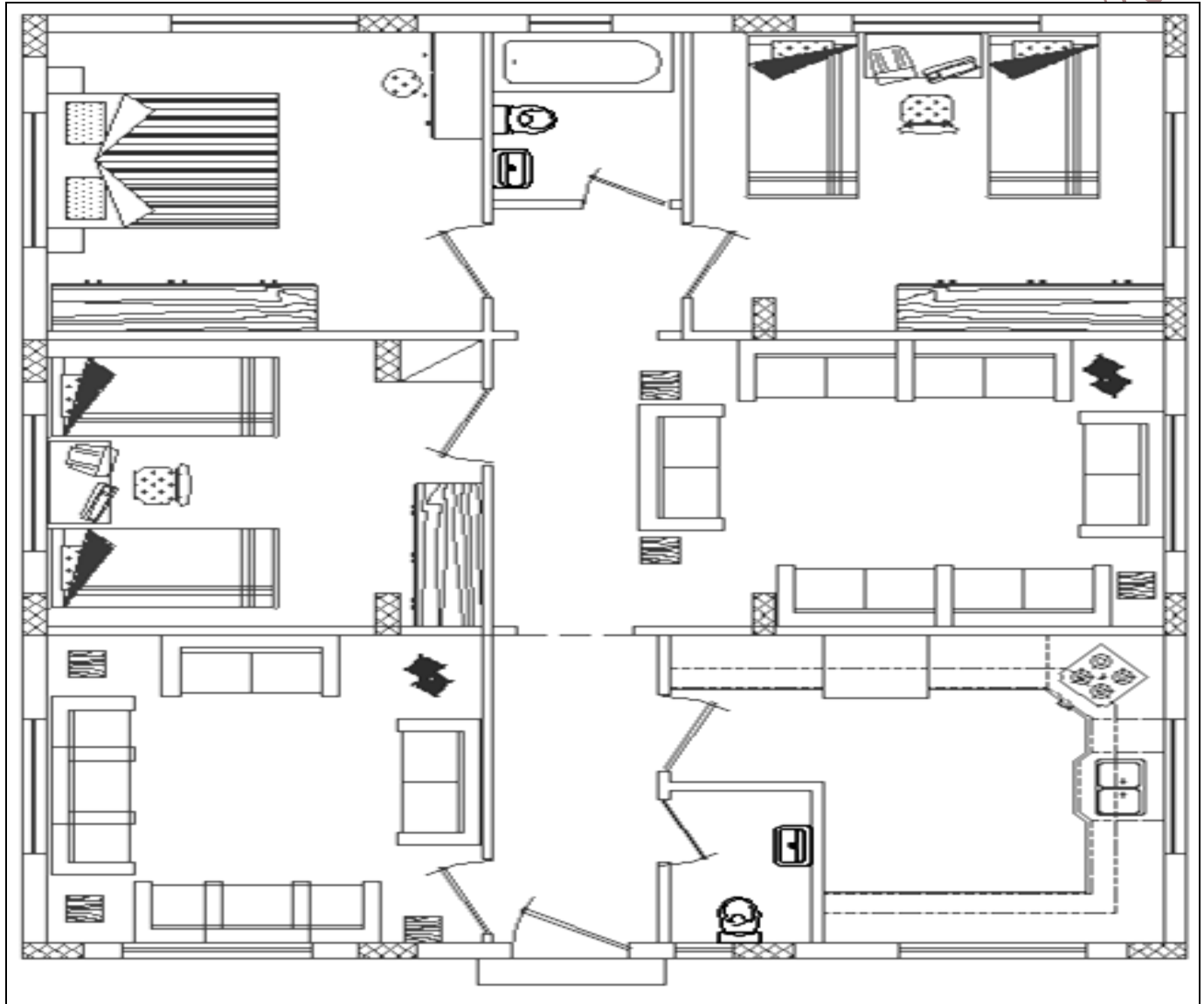

Figure 4.1 House Plan

► **Procedure:**

Click  ► Open ► Drawing4.dwg

Where this file contains a drawing of house design.

➤ **PARTA: Lighting Plan :**

1. In the same file that is open make a copy of the design “drawing4\_light.dwg”
2. Distribute the light elements for all rooms then draw your distribution in the copy of the design.
3. Save your work
4. Distribute the switches for every room in the design, then draw your distribution in the copy of the design
5. Distribute the LDBG (Light Distribution Board Ground) elements in the design, then draw your distribution in the copy of the design
6. Save your work
7. Make wires between the light elements and the switches where used, then draw your distribution in the copy of the design
8. Save your work

➤ **PARTB: Power Plan:**

10. In the same file that's open make a copy of the design “drawing4\_power.dwg”
11. Distribute the socket outlets for all rooms, then draw your distribution in the copy of the design.
12. Save your work
13. Distribute the switches for socket outlets, where needed
14. Distribute the SDBG (Socket Distribution Board Ground) elements in the design, then draw your distribution in the copy of the design
15. Save your work
16. Make wire between the socket outlet and the switches, where used, then draw your distribution in the copy of the design
17. Save your work

➤ **PARTC: Extra Low Voltage Plan:**

1. In the same file that's open make a copy of the design. “drawing4\_lowvolt.dwg”
2. Distribute the Audio, Video, Telephone, Intercom, Alarm System, for all rooms, then draw your distribution in the copy of the design
3. Save your work

4. Distribute the ELDBG elements in the design, then draw your distribution in the copy of the design.
5. Save your work

➤ **PARTD: Earthing system:**

4. In the same file that's open make a copy of the design
5. Draw the earthing system for the design
6. Save your work

➤ **PARTE: Power and Rizer Diagram:**

In the same file draw the following diagram:

7. MDB (Main Distribution Board) Diagram
8. DBG (Distribution Board of Ground Floor) Diagram
9. ELV(Extra Low Voltage) - RIZER Diagram
10. DB (Distribution Board) RIZER Diagram
11. Main Earthing Bus Bar
12. Save your work

*Electrical and Computer Engineering Department-BZU, 2015*

## Experiment # 5

### Three Phase Electrical Plan Design

#### ➤ **Objectives:**

In this experiment the plans for three phase electrical installations will be designed and drawn.

1. Lighting Plan
2. Power Plan
3. Extra Low Voltage (ELV) Plan
4. Power, Rizer Diagram, and Distribution Board
5. Earthing system
6. ELV Rizer Diagram

#### ➤ **Introduction:**

Three phase wiring distribution is simply distributing power supply with 3 live incoming supplies instead of the single phase, which uses only one power supply line. In a normal domestic environment where 3 phase equipments are rarely used, the extra 2 live supplies ensures that the user does not overload the permitted amperage allowed by a single phase supply. Due to the increment of power used in modern homes, power shortage is often a problem faced by house owners. Thus many new houses come equipped with 3 phase supplies. The advantage is, of course, they having extra electrical power to spread around, thereby they do not have to worry about the risk of overloading one single line.

#### **Even Distribution of Three Phase Wiring Supply:**

In using a 3 phase wiring supply, utmost care must be taken to ensure that no one phase is loaded heavier than the other. Thus the electrician entrusted with the job of installing the electrical system of the house must be knowledgeable in 3 phase power distribution. He must also know how to calculate the electrical consumption of all the electrical equipments intended for use in the house. For example, a house may have 4 Air-Conditioning units, an Oven, 2 refrigerators, A

Cooker and a washing Machine, which are power hungry electrical items. If all these equipments are loaded into one single phase supply, then that phase will definitely be overloaded. Note that all the electrical equipments are distributed equally amongst the 3 phase supply and no one single phase is overloaded. This should be the most proper way in 3 phase wiring power distribution.

This section looks at the services that need connection and what the typical connection types required are. The services that need connectivity from an outside party are:

- Electricity supply
- Telephony
- Internet
- TV
- Audio
- Security

How services are connected will vary depending on the service provider and location of the house.

#### **Power Points:**

They need to be installed throughout the house in locations where power will be required. In most countries, the installation must be done in compliance with standards and by a licensed or qualified electrician. Power points are typically located where there will be an appliance installed such as, telephones, computers, television, home theater, and security system, or any other appliance.

#### **Light Fittings:**

This is even more of a challenge than the power point as the number of light fitting does depend on the type of light fitting. So for this reason we cannot give you much as it depends on the function of the room. So work out the function or functions of each room and identify where you need to install various light fittings and which group of light you would need depending on the use of the room, then you can determine cables size, numbers, length and where. In most

countries the installation must be done in compliance with standards and by a licensed or qualified electrician.

### **Telephone:**

To allow the connection of telephone points you need to have cabling installed from the point where the telephone company has installed their cabling to where you want the phone sockets. In many of the new houses this is typically located near the electrical switch board but not always. You need to identify where you want the phone system or handset physically connected. Probably the best location is in the restroom and possibly the study Area. The telephone cabling typically uses two-pair twisted cable terminated onto a telephone plug.

### **Data:**

Data wiring has two components, these are:

#### **A-Data Service Delivery:**

The three most common ways data services are delivered to the home:

**1- Asynchronous Data:** are typically delivered using the telephone cabling. **ADSL** so wherever you have a telephone point you can install your ADSL modem. When you have an ADSL modem you also need to install a filter at every location where you have a phone plugged in. If you want to install the ADSL modem in a room where you do not have any phone point you will need to install a phone point by extending the phone cabling from the nearest existing phone point.

**2-Cable Modem:** are typically installed in location where there is an existing TV service outlet.

**3- Fiber:** is the least common but it is growing in numbers. If the home has fiber next to it then the fiber terminates on what is known as an Optical Network Termination unit (ONT) and it has a data port on it. Cabling from the street to the point where the ONT is installed is fiber and is typically installed by the service provider.

In all three cases the modem supplied or the ONT will have a data port which is an RJ45 socket and this is the port that needs to be connected to the devices you need to connect to the internet. This is the data network cabling or LAN cabling (Local Area Network).

### **B-Data Network Cabling:**

To extend the data service from the data port on the ADSL modem, Cable Modem or ONT to your networking devices (PC, printers, TV etc.) you need to install data cabling also referred to as LAN cabling. The cabling used for data networking is similar to the phone cabling as it is twisted pair but of a much higher quality. The cable is known as Cat 5 or Cat 6 where Cat stands for Category. What you need to do is decide where your networking devices are and install cabling from the location where the data modem is located to where you have your PCs or TVs that need to connect to the internet. The cabling must be installed as a star wired configuration, that is the cabling runs from the point next to the modem uninterrupted up to where you install the outlet next to the device that needs to be connected to the internet. So unlike the phone wiring where you could wire from one outlet to the next, here each outlet is wired individually back to the location next to the modem. Therefore, next to the modem you will have what is known as a patch panel. Note, if all you need to plug into the modem is one computer, then you can simply buy an Ethernet cable of the desired length and connect to between the modem and the PC.

### **TV:**

Cabling for free to air TV requires the following:

1. An antenna or dish.
2. Coaxial cable
3. TV outlets

**Security Monitoring:** Security monitoring (**Burglar alarm**) systems contain basic components of:

1. Main panel
2. Code pad
3. Motion detectors, infrared, proximity, ultrasonic
4. Siren and strobe light

### **Automation:**

Automation refers to the ability to be able to control a range of devices in the home ranging from lights to curtains. The most common example of automation is referred to as Lighting control



system. Lighting control system need to be installed by a qualified professional as the cabling is only one element but without the equipment and programming you cannot even turn a light on. The cabling required when installing an automation system can be divided into two parts:

1. Electrical
2. Data Bus

**Electrical:** This is cabling installed from the electrical switchboard to the light fitting or any other device that is to be controlled by the automation system. For example if you have four down lights in a room and you wish to control each light individually, then each light will be wired back using electrical cabling back to the electrical switchboard. This means you will have four electrical cables installed from the electrical switchboard to the location where the light fittings will be installed. Each cable will be a three core; live, neutral and earth cable. If in that room you also have a free standing lamp plugged into a power point and you also want to control this from your automation system, you will need to have that power point individually wired back to the electrical switchboard. So if you want to individually control every light fitting and every power point or power outlet, then each one of these devices must be individually wired back to the electrical switchboard. It is clear that a lot of electrical cabling is needed, hence planning is essential.

Note, when you are using an automation system, there is no need to install any electrical cabling to the light switches. In a traditional electrical installation without automation the lights in a room would be wired back to the light switch which in turn would be wired back to the switchboard or some similar arrangement.

**Data Bus:** Once you have installed the electrical cabling you need to install the data bus cable from the electrical switchboard to every location you want to have a light switch or control panel installed (control panel is like the code pad on a security system or touch screen that gives you access to various control functions). The most common cable used for this is a Category 5 cable. The cable can be installed in either a daisy chain or star wired configuration. The importance is to minimize the cable length to avoid communication problems on the bus.

### **Energy Management:**

Energy management is a new and upcoming topic in particular in Domestic Installation. Older systems tended to be cabled. However, all new systems use one of a variety of wireless solutions. This enables them to be effectively retrofitted into existing homes with the minimum of disruption.

The major appliances being considered at this stage are:

1. Electric hot water system
2. Air Conditioning
3. Pool pump
4. Fridge / freezer

### ➤ **Prelab:**

Print the design as shown in Figure 5.1, and then prepare your design by hand on 4 papers for the following plan:

5. Lighting Plan
6. Power Plan
7. Extra Low Voltage Plan
8. All Power and Rizer Diagram.

### **Note:**

Distribute the load on the 3 phase almost equally.

### **Specifications:**

#### **9. Main Hall:**

- 40 Ceiling Lighting Point and Fluorescent lamps.
- 9 spot lights
- 8 Circuit Switches
- 10 Power socket-single phase
- 4 Loud Speaker
- 6 Smoke Detector
- 6 Air Conditioning Units

**10. Kitchen:**

- Two Circuit Switch
- 2 Ceiling Lighting Point or Fluorescent lamps
- 8-12 Power sockets
- One Smoke Detector

**11. Management Room:**

- One Circuit Switch
- 2 Ceiling Lighting Point or Fluorescent lamps
- 5 Power sockets
- Intercom Outlet
- Television Outlet
- One Smoke Detector
- One Air Conditioning Unit

**12. Control Room:**

- One Circuit Switch
- 3 Power sockets
- One Air Conditioning Unit
- Mic socket
- Amplifier
- One Smoke Detector
- Ceiling Lighting Point or Fluorescent lamps

**13. Other Room:**

- One Circuit Switch
- 3 Power sockets
- Ceiling Lighting Point or Fluorescent lamps
- One Air Conditioning Unit

#### 14. Two Entrances:

- 6 spot lights/each
- Two Ceiling Lighting Point
- Circuit Switch as the design need.
- One Smoke Detector
- 2 Power sockets

BZU, 2015

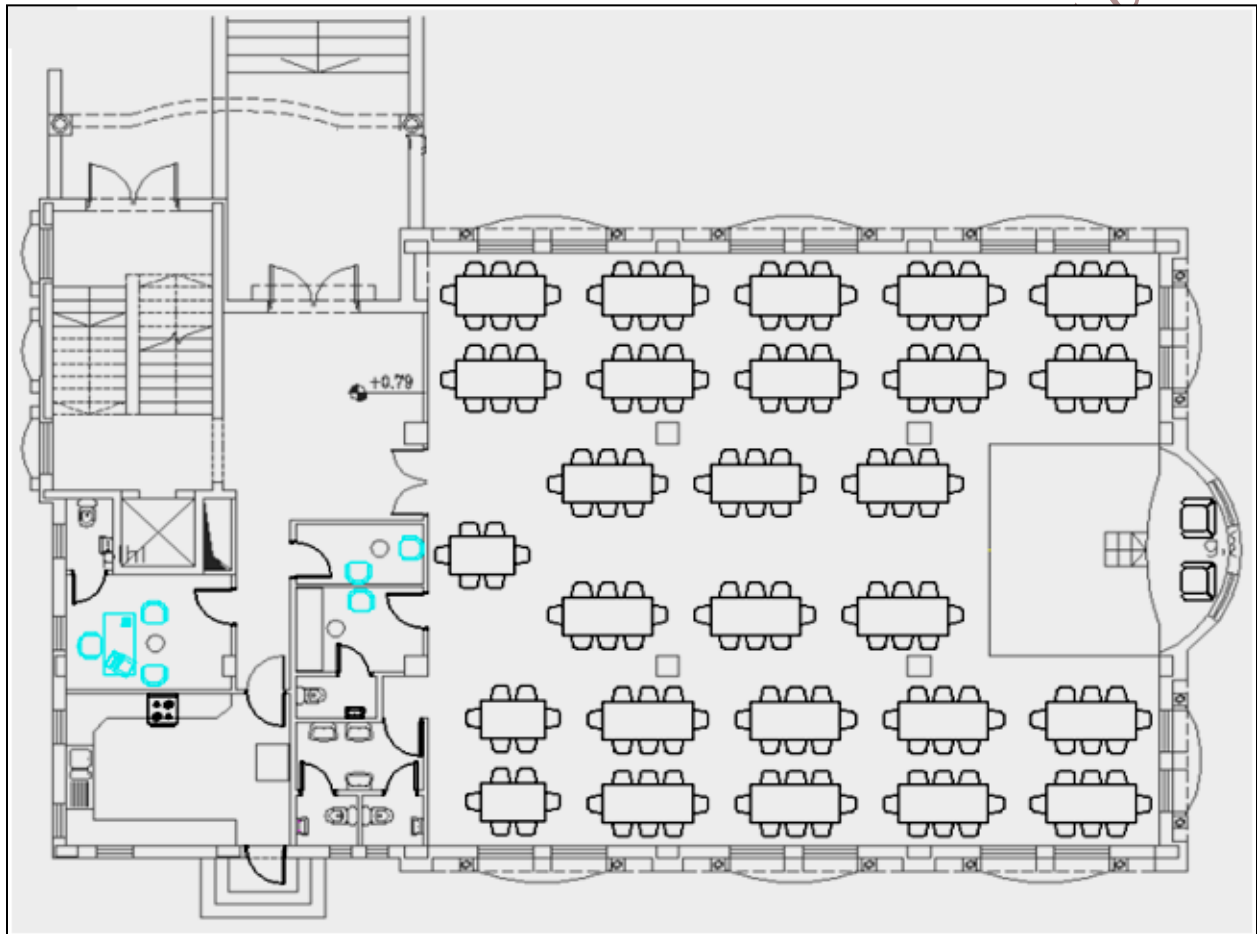

Figure 5.1 Construction plan of Ground floor (Hall)

#### ➤ Procedure:

Click  ➤ Open ➤ Drawing5.dwg

Where this file contains a drawing of home design.

➤ **PART A: Lighting Plan:**

11. In the same file that is open make a copy of the design “drawing5\_light.dwg”/ or make layers
12. Distribute the light elements for all rooms then draw your distribution in the copy of the design.
13. Save your work.
14. Distribute the switches for every room in the design, then draw your distribution in the copy of the design.
15. Distribute the **LDG** (Light Distribution Board floor Ground) Elements in the design, then draw your distribution in the copy of the design.
16. Save your work.
17. Make wire between the light elements and the switches where used, then draw your distribution in the copy of the design.
18. Save your work.

➤ **PART B: Power Plan:**

18. In the same file that’s open make a copy of the design “drawing5\_power.dwg”/or make a second layer.
19. Distribute the socket outlets for all rooms, then draw your distribution in the copy of the design.
20. Save your work.
21. Distribute the switches where needed, for socket outlets.
22. Distribute the **SDBG** (Socket Distribution Board Ground) elements in the design, then draw your distribution in the copy of the design.
23. Save your work.
24. Make wiring between the socket outlet and the switches, where used, then draw your distribution in the copy of the design.
25. Save your work.

➤ **PART C: Extra Low Voltage Plan:**

6. In the same file that’s open make a copy of the design. “drawing5\_lowvolt.dwg”/or make a third layer.

7. Distribute the Audio, Video, Telephone, Intercom, Alarm System, for all rooms, then draw your distribution in the copy of the design.
8. Save your work.
9. Distribute the ELDBG Element in the design, then draw your distribution in the copy of the design.
10. Save your work.

➤ **PART E: Earthing System:**

In the same file that's open make a copy of the design. "drawing5\_earthing.dwg"/or make a 4<sup>th</sup> layer.

7. Draw the earthing system for the design.
8. Save your work.

➤ **PART D: Power and Rizer Diagram:**

In the same file draw the following diagram for the design:

13. MDB (Main Distribution Board) Diagram.
14. DB (Distribution Board) Diagram.
15. ELV(Extra Low Voltage) - RIZER Diagram.
16. DB (Distribution Board) RIZER Diagram.
17. Main Earthing Bus Bar.
18. Save your work.

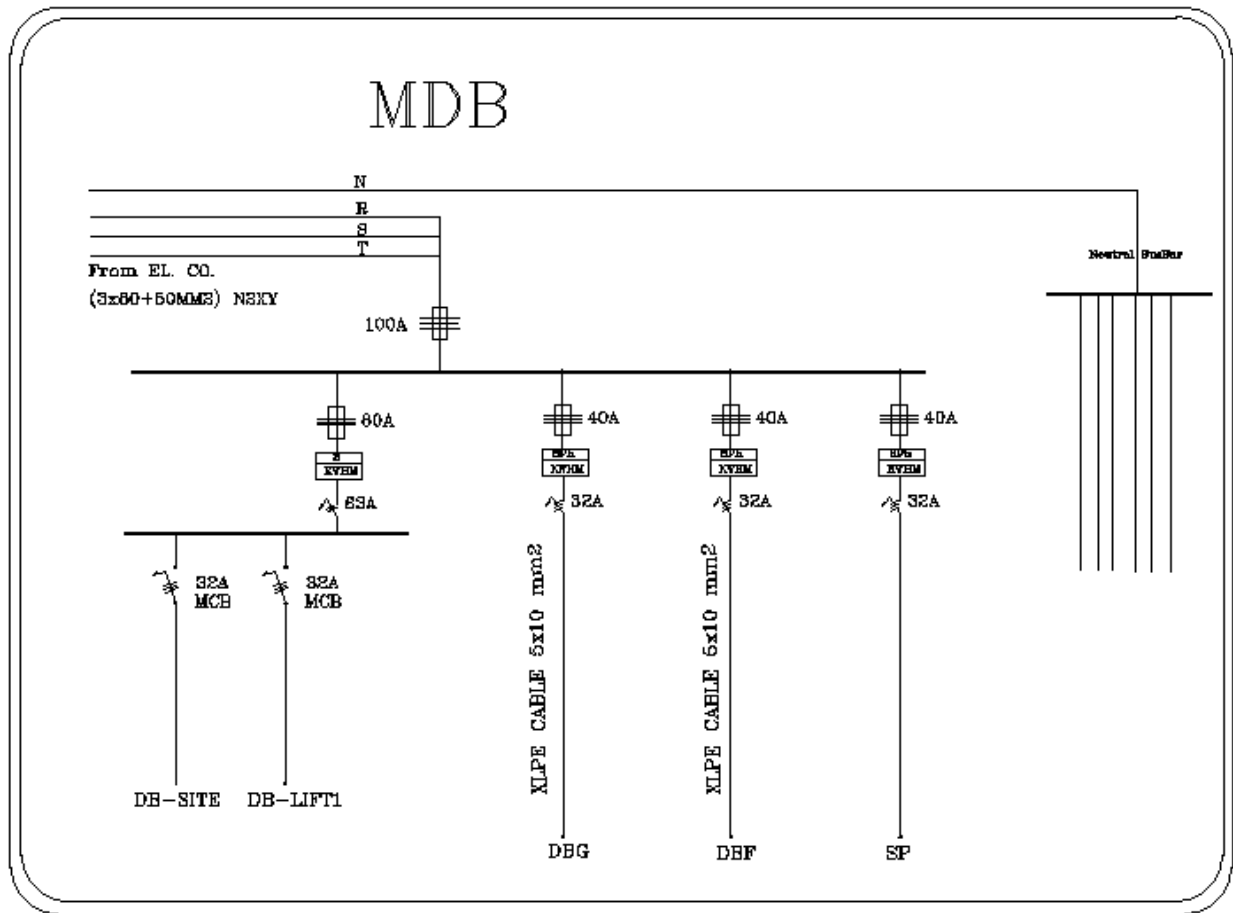

Figure 5.2 MDB (Main Distribution Board) Diagram

Where:

DBG: Distribution Board for Ground Floor

DBF: Distribution Board for First Floor

SP: Spare

DB\_LIFT: Distribution Board for Lift.

DB\_SITE: Distribution Board for Site. (No need to design)

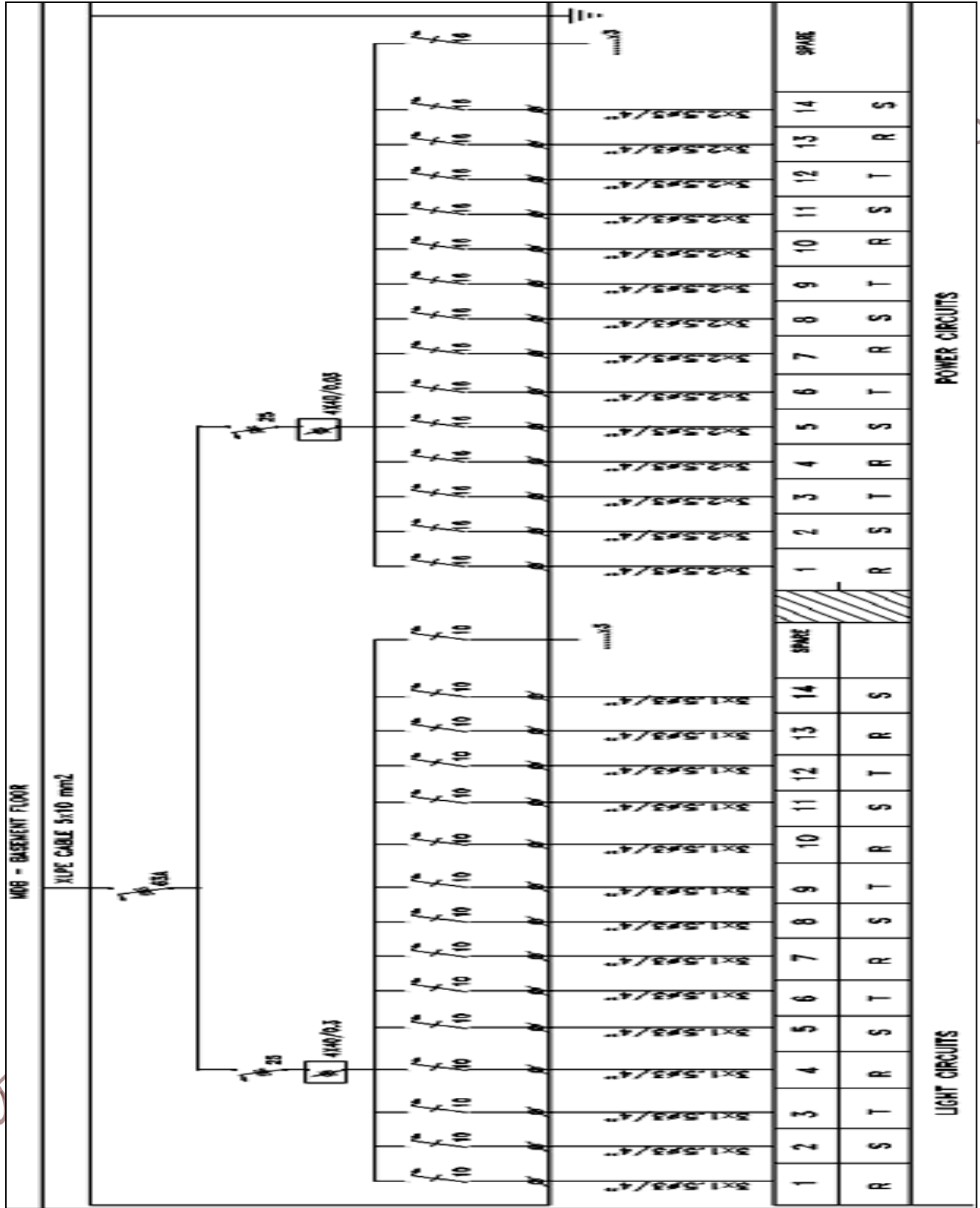

Figure 5.3 DBG (Distribution Board for Ground Floor) Diagram



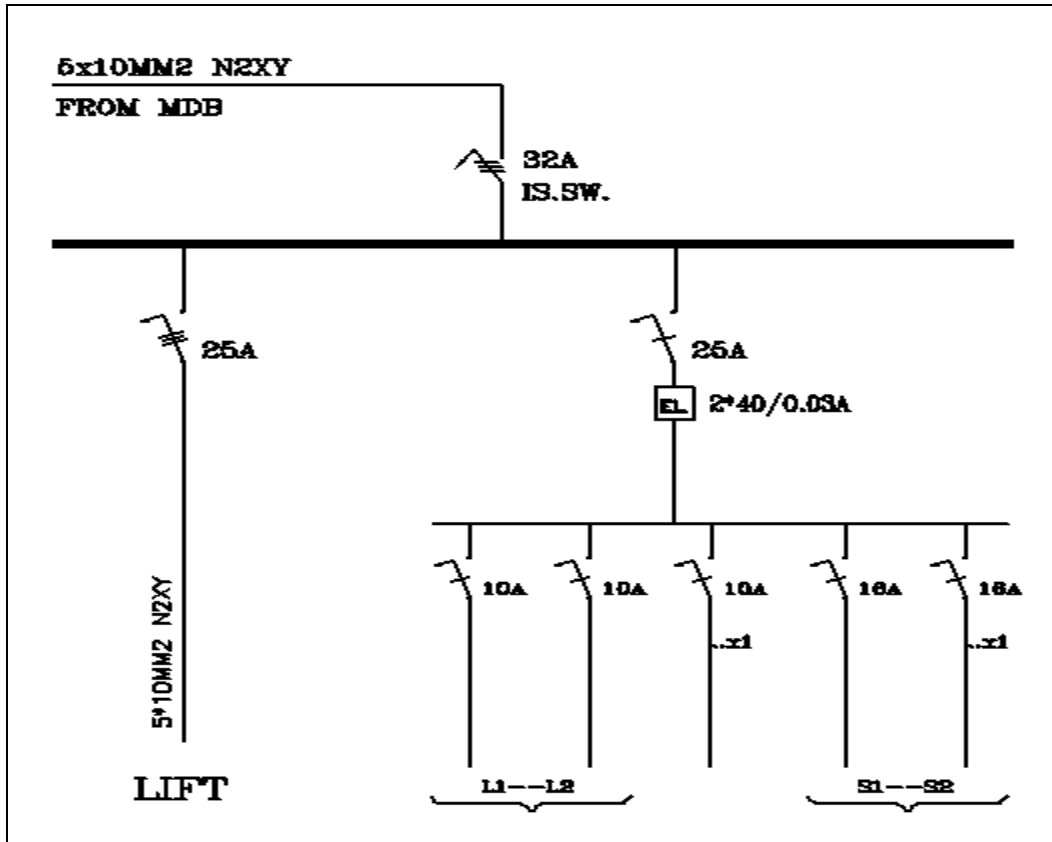

Figure 5.4 DB\_LIFT (Distribution Board for Lift) Diagram

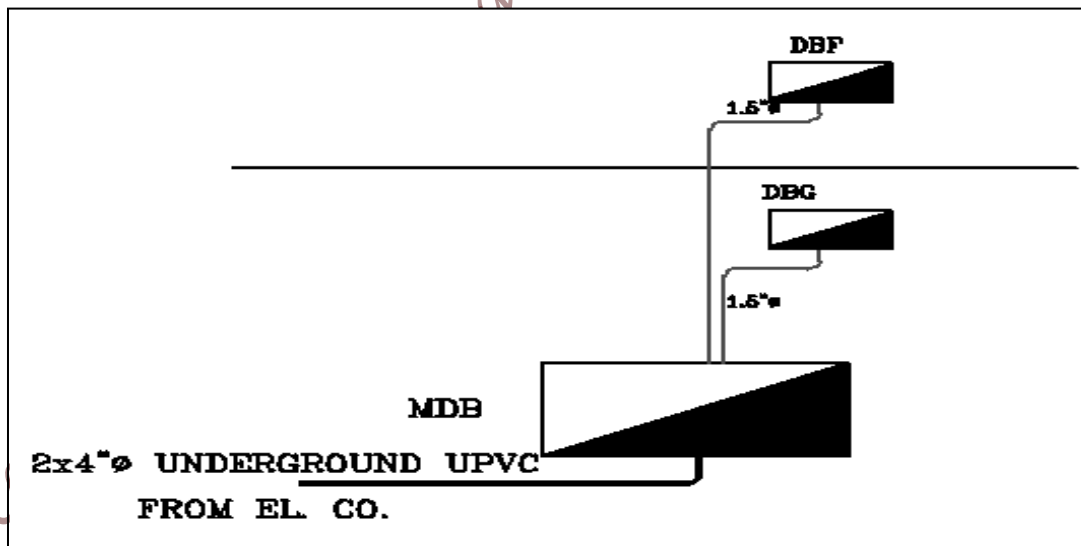

Figure 5.5 DB (Distribution Board) RIZER Diagram

2015

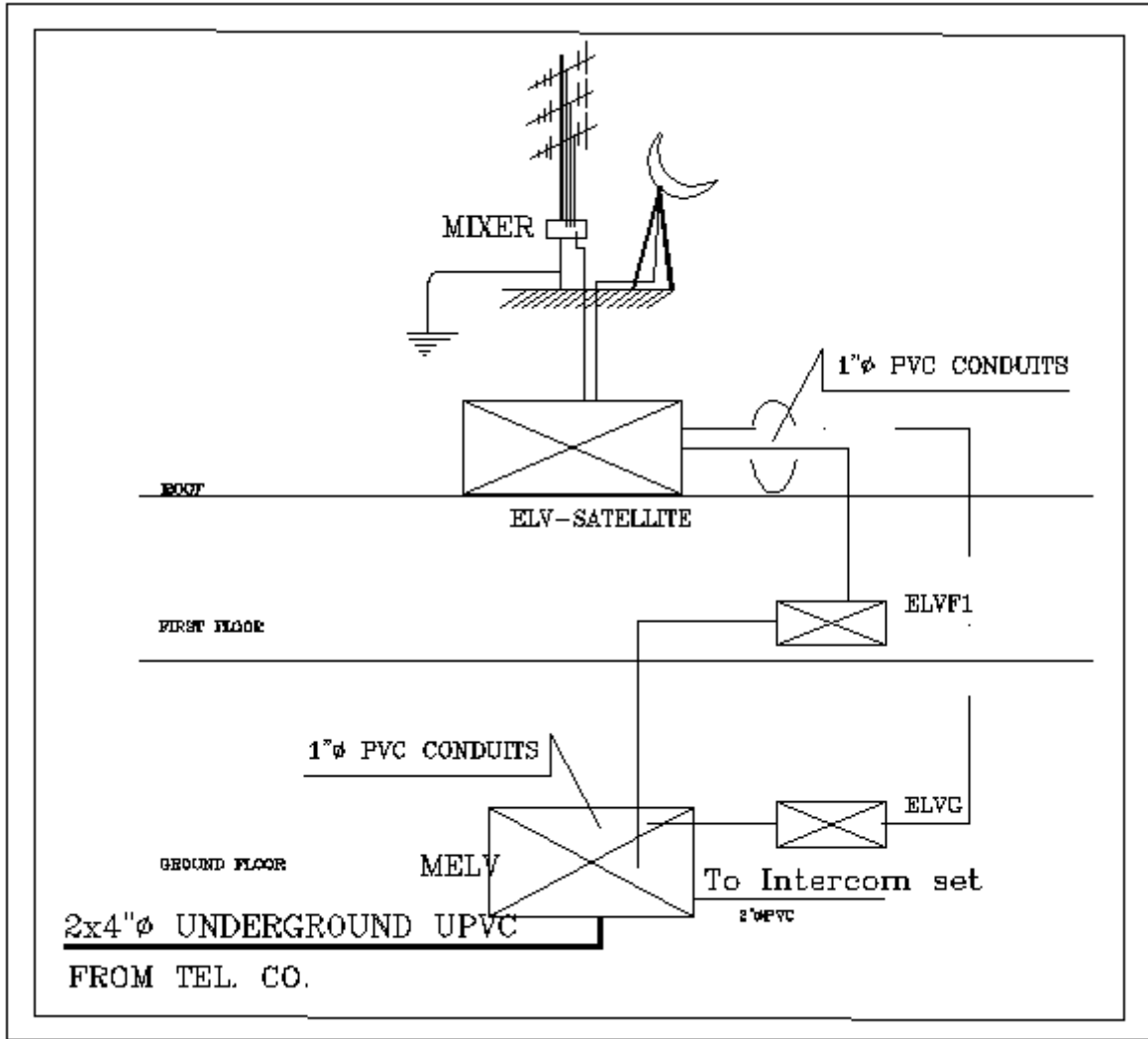

Figure 5.6 ELV (Extra Low Voltage) RIZER Diagram

## Experiment # 6

### Engineering Drawings

#### ➤ **Objectives:**

The main objectives of this experiment are:

1. Creating 2D drawings
2. Utilizing and using 3D commands
3. To be familiar with a 3D workspace
4. To be able to create a 3D drawings

#### ➤ **Introduction:**

Engineering drawing is a detailed, technical drawing of an object, such as furniture, to show each part and its dimensions. Engineering drawings are used in numerous fields, and are done by drafters. A draftsman uses different tools which are specifically used to add detail to the drawing. Engineering drawings can be created manually, but are often created using special computer software.

Engineering drawing is a type of technical drawing which shows information about mechanical systems like heating, ventilation and air conditioning. Technical drawing, also called "drafting," is a particular form of drawing used by designers, architects and engineers. There is a number of standards and conventions for technical drawings, as technical drawings are meant to show information and are interpreted as such. Elements like layout, text, symbols, types of view projections, dimensioning, descriptive geometry and line thickness are all standardized in technical drawing.

These drawings are mainly for the use of architects when they need exact, detailed drawings of a part of a building, such as a column; for interior designers when they need exact, detailed drawings of a piece of furniture; and by design engineers who need exact, detailed drawings of any object that needs to be manufactured.

Engineering drawings are used so that the people who build the specific object will create it exactly as the person who designed it, such as the architect or engineer, intended it to be. Every detail of the drawing, such as materials used and measurements, can be seen in the drawing so that the actual object can be built correctly. 3D Engineering drawings are created for objects from buildings to bridges, automobiles, refrigerators, and furniture.

Before computers, architectural designers and engineers completed all their projects using a mechanical drawing board and tools made to specifically accomplish diagrams and drawings, based on precise measurements. Today, the mechanics of the drafting task have largely been automated and accelerated through the use of computer-aided design systems (CAD).

There are two types of computer-aided design systems used for the production of technical drawings" two dimensions ("2D") and three dimensions ("3D").

2D CAD systems such as AutoCAD replace the paper drawing discipline. The lines, circles, arcs and curves are created within the software. It is down to the technical drawing skill of the user to produce the drawing. There is still much scope for error in the drawing when producing first and third angle orthographic projections, auxiliary projections and cross sections. A 2D CAD system is merely an electronic drawing board. Its greatest strength over direct to paper technical drawing is in the making of revisions. Where as in a conventional hand drawn technical drawing, if a mistake is found, or a modification is required, a new drawing must be made from scratch. The 2D CAD system allows a copy of the original to be modified, saving considerable time. 2D CAD systems can be used to create plans for large projects such as buildings and aircraft but provide no way to check the various components will fit together.

3D CAD systems such as Autodesk Inventor or SolidWorks first produce the geometry of the part, the technical drawing comes from user defined views of the part. Any orthographic, projected and section views are created by the software. There is no scope for error in the production of these views. The main scope for error comes in setting the parameter of first or third angle projection, and displaying the relevant symbol on the technical drawing. 3D CAD allows individual parts to be assembled together to represent the final product. Buildings,

Aircraft, ships and cars are modeled, assembled and checked in 3D before technical drawings are released for manufacture.

Both 2D and 3D CAD systems can be used to produce technical drawings for any discipline. The various disciplines; electrical, electronic, pneumatic, hydraulic, etc., have industry recognized symbols to represent common components.

Before entering the exciting world of 3-D, you'll have to learn some more CAD terminology. This level presumes that you have a good understanding of 2D commands.

### 3-D CAD TERMINOLOGY:

2-D	A concept of displaying real-world objects on a flat surface showing only height and width. This system uses only the X and Y axes.
3-D	A way of displaying real-world object in a more natural way by adding depth to the height and width. This system uses the X Y and Z axes.
Boolean operations	Commands that allow you to add, subtract or intersect solid objects in AutoCAD.
Complex surface	Generally a curved surface. Examples: car fender, landscape contour.
Elevation	The difference between an object being at zero on the Z-axis and the height that it is above zero.
Extrude	The extrude command raises the shape of a 2D outline into a 3D solid. For example, a circle would be extruded into a cylinder.
Face	The simplest true 3-D surface.
Facet	A three or four sided polygon that represents a piece (or section) of a 3-D surface.
Hidden line removal	A way of hiding lines that would not be visible if you were viewing the actual object you have drawn in AutoCAD. (Command: HIDE)
Isometric Drawing	A simple way of achieving a '3-D' appearance using 2-D drawing methods.
Plan View	Also known as the top view, a plan view looks directly down the WCS Z-axis to the X-Y axis.
Primitive	A basic solid building block. Examples would be boxes, cones, cylinders.
Region	A 2-D area consisting of lines, arcs, etc.
Rendering	A complex way of adding photo-realistic qualities to a 3-D model you

	have created.
Shading	A quick way of adding color to a 3-D object you have drawn. (Command: SHADE)
Solid Model	A 3-D model creating using solid 'building blocks'. This is the most accurate way of representing real-world objects in CAD.
Surface Model	A 3-D model defined by surfaces. The surface consists of polygons. (See facets.)
Thickness	A property of lines and other objects that gives them a 3-D like appearance.
UCS	The user co-ordinate system. This is defined by the person drawing to have easier access to portions of a 3-D model.
View	A particular view of the object you have created.
Viewport	A window into your drawing showing a particular view. You can have several viewports on your screen. Different from the viewports used in plotting.
Wire-frame Model	A 3-D shape that is defined by lines and curves. A skeletal representation. Hidden line removal is not possible with this model.
Z-Axis	The third axis that defines the depth.

➤ **Prelab:**

1. Click  ➤ New .

Save your file as ➤ PreLab6.dwg

- **Workspaces:**

1. Click the Workspace Switching icon.



2. Click **3D Modeling** and **OK**.

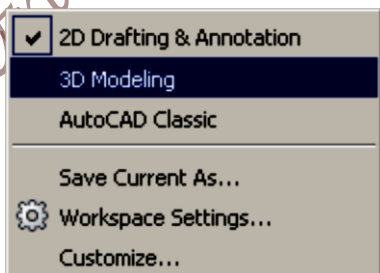

- **Creating a box:**

You can create a rectangular or cubical solid box. Box objects can form a basic structure that you can resize or combine with other objects.

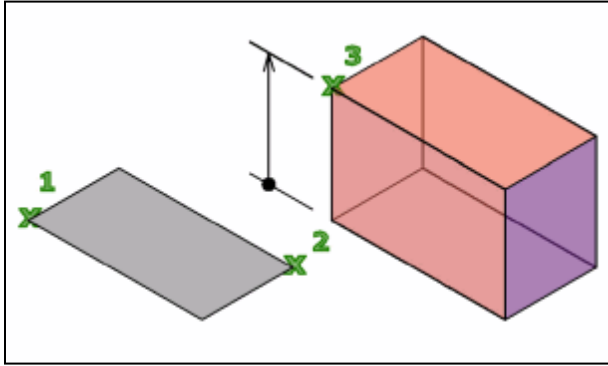

The following steps explain how to create a box.

1. On the ribbon, click Home tab > View panel > Visual Styles drop-down > Conceptual

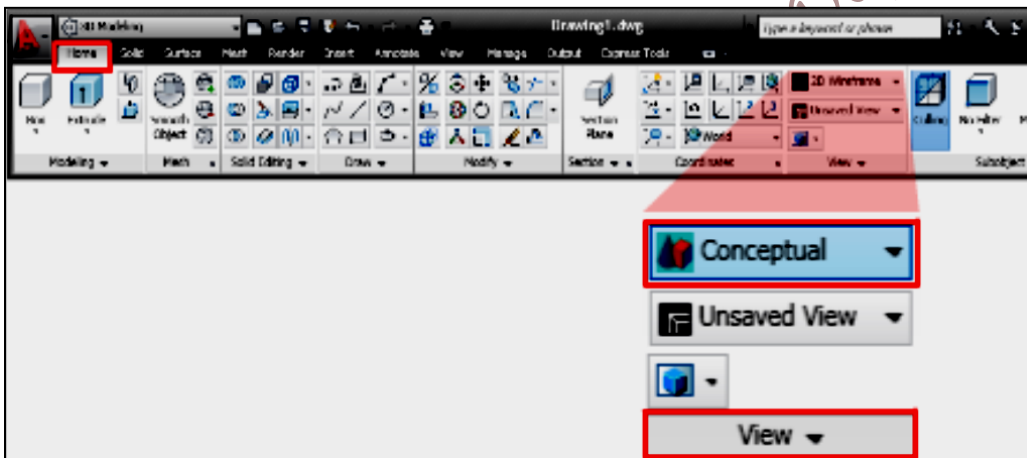

2. On the ribbon, click Home tab > Modeling panel > Solid Primitives drop-down > Box.

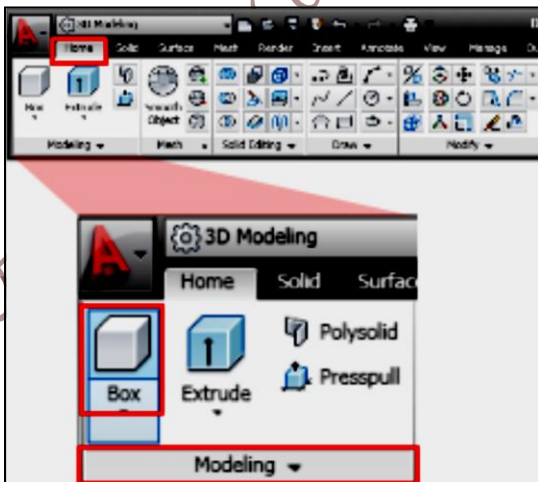

3. At the prompt, click any point in the drawing to specify a base point
4. At the prompt, enter @ 8,8 for the opposite corner and press Enter
5. At the prompt, enter 5 for height and press Enter

The base of the box is always drawn parallel to the XY plane of the current UCS (workplane). The height of the box is specified in the Z axis direction. You can enter both positive and negative values for the height

6. On the ViewCube, located at the upper-right corner of the drawing window, click Top, Front, Left, and Right to navigate around the sheet.

#### - **Creating Cylinder:**

You can create a cylinder with a circular or elliptical base.

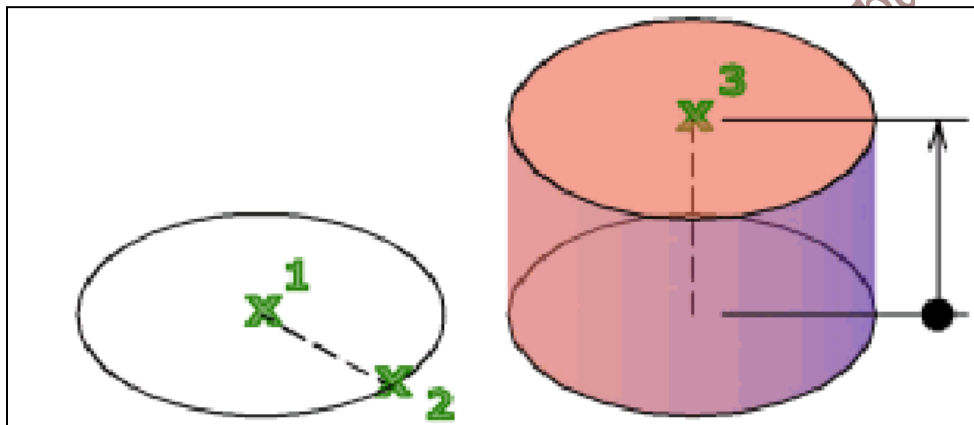

The following steps explain how to create a cylinder:

1. On the ribbon, click Home tab > Modeling panel > Solid Primitives drop-down (under box icon) > Cylinder.
2. At the prompt, click any point in the drawing to specify a base point
3. At the prompt, enter 5 for radius and press Enter
4. At the prompt, enter 8 for height and press Enter

#### - **Visual Styles:**

A visual style is a collection of settings that controls the display of edges and shading in the viewport.

1. Choose View, Visual Styles and one of the following style options.



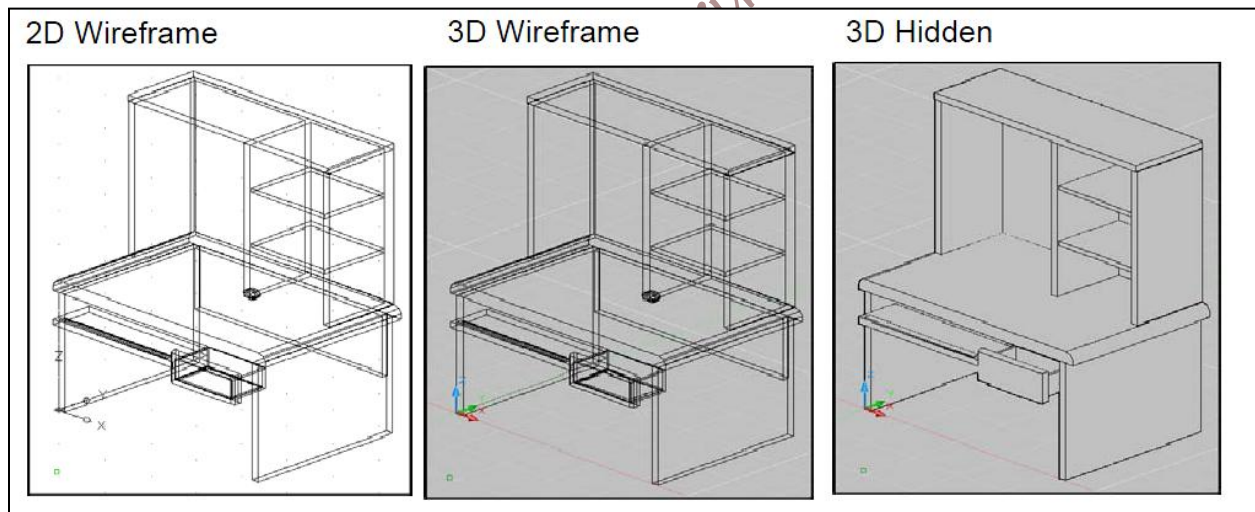
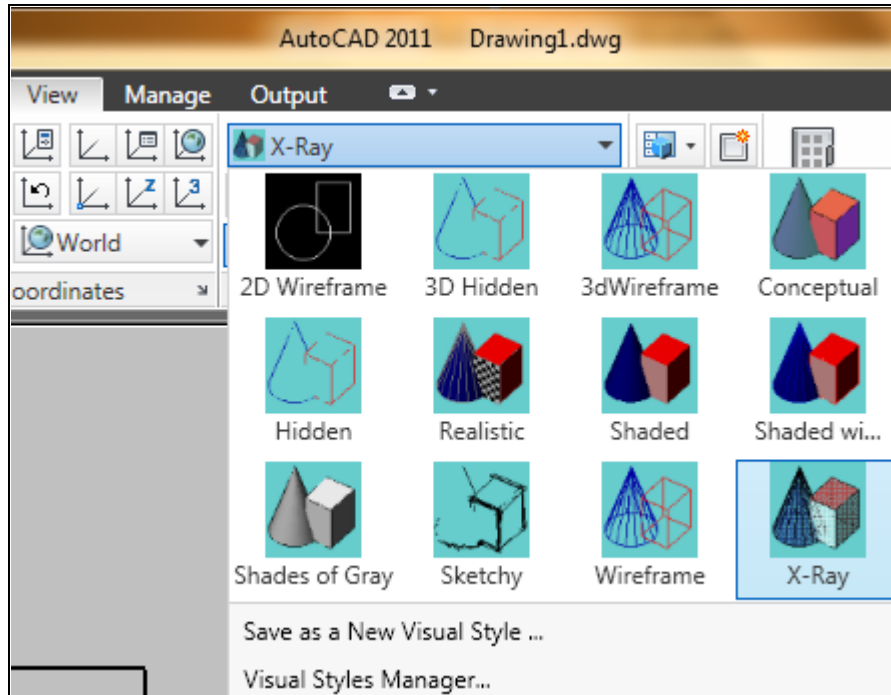

- **Surfaces:**

Surface modeling is more sophisticated than wireframe modeling in that it defines not only the edges of a 3D object, but also its surfaces. The AutoCAD surface modeler defines faceted surfaces using a polygonal mesh. Because the faces of the mesh are planer, the mesh can only approximate curved surfaces.

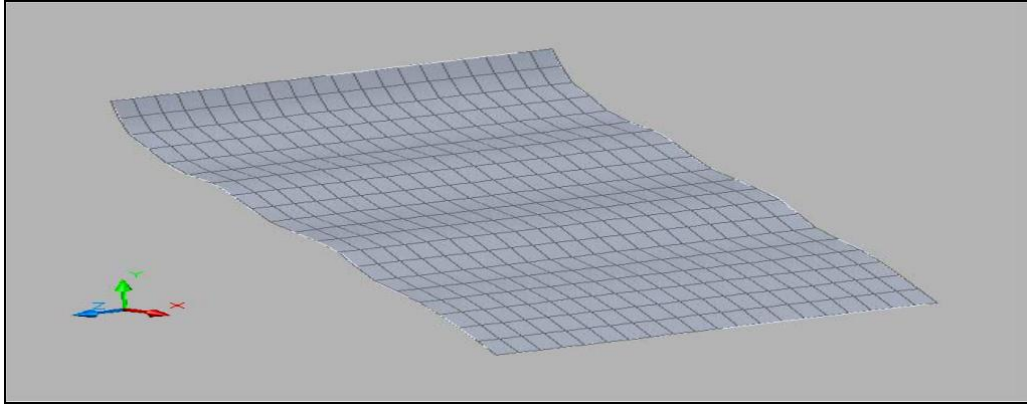

### Solids:

Solid modeling is the easiest type of 3D modeling to use. With the AutoCAD solid modeler, you can make 3D objects by creating basic 3D shapes: boxes, cones, cylinders, spheres, wedges, and tori (do- nuts). You can then combine these shapes to create more complex solids by joining or subtracting them or finding their intersecting (over- lapping) volume. You can also create solids by sweeping a 2D object along a path or revolving it about an axis.

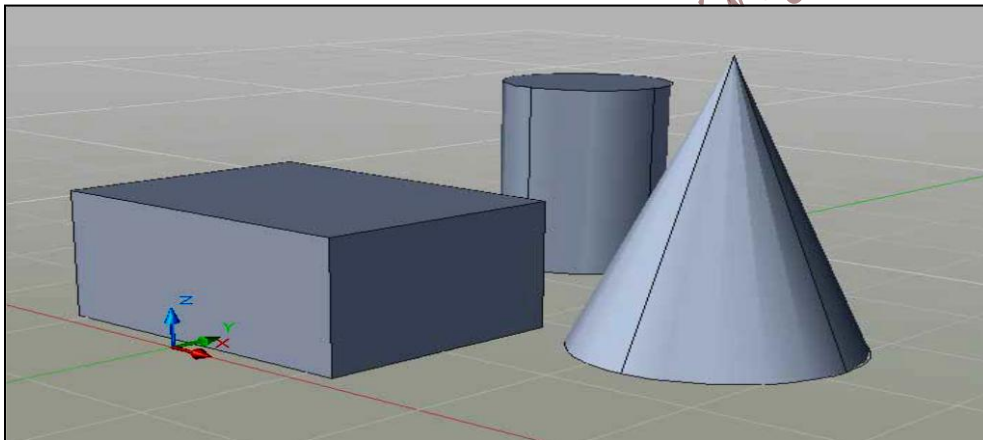

#### - 2D Solid:

Creates solid-filled triangles and quadrilaterals.

1. Type SOLID at the command prompt.

Command: solid

First point: P1

Second point: P2

Third point: P3

Fourth point: P4

Then enters

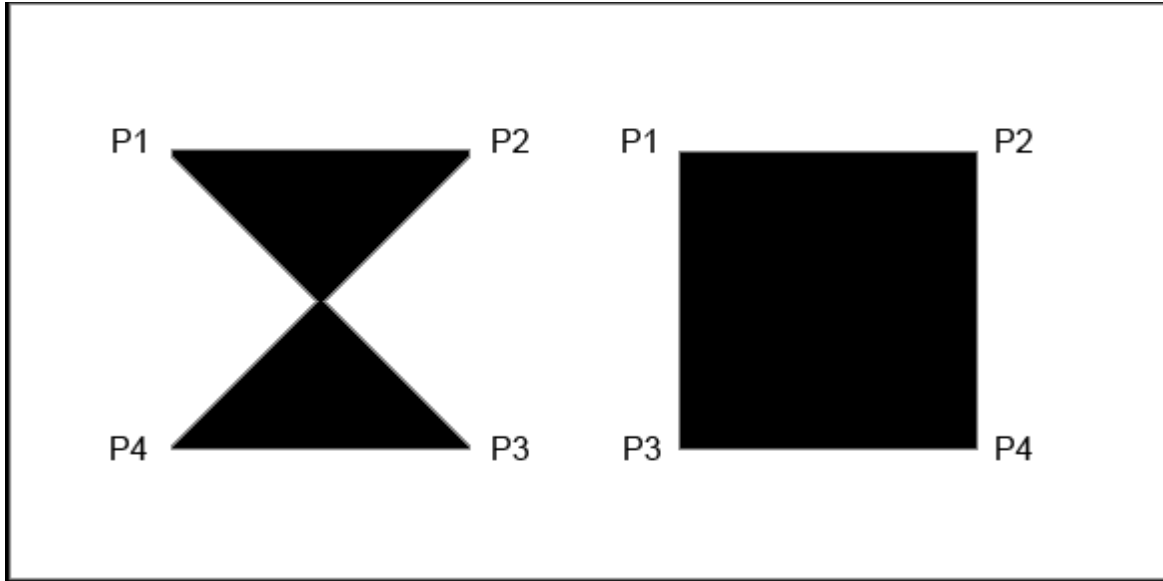

2015

- **3D Faces:**

3DFACE creates a three or four sided surface anywhere in 3D space. You can specify different Z coordinates for each corner point of a 3D face. 3DFACE differs from SOLID, which creates a three- or four-sided surface that is parallel to the current UCS and can be extruded.

1. Type 3DFACE at the command prompt.

Command: 3dface

First point: pick

Second point: pick

Third point: pick

Fourth point: pick

Then enters

3D Wireframe Lines

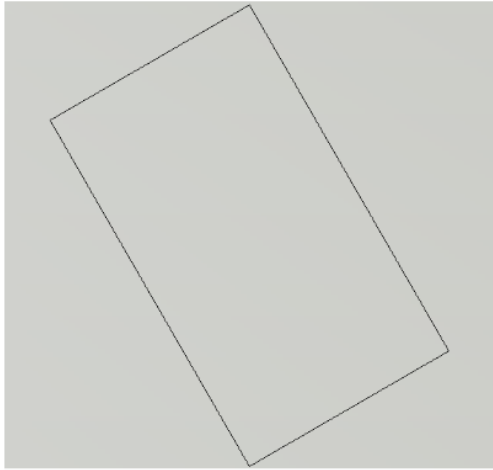

3D Face

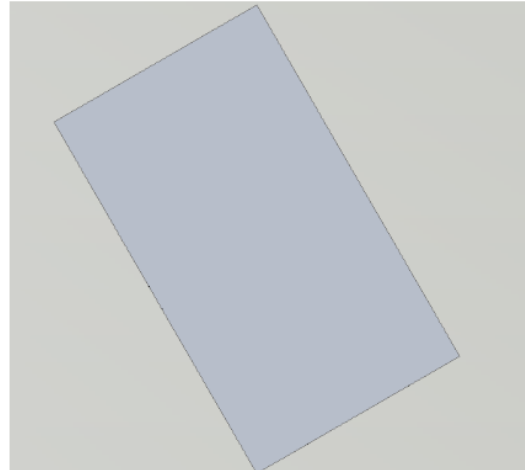

- **Viewports:**

1. Draw the following figure

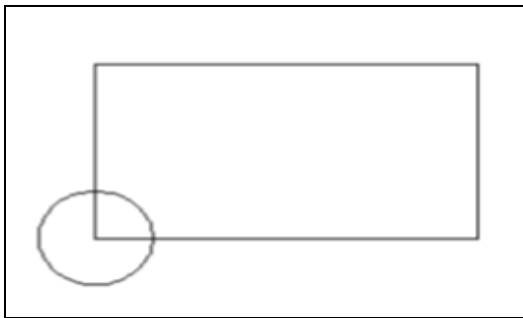

2. Type -VPORIS at the command prompt.

Command: **-VPORIS**

3. Enter an option [Save/Restore/Delete/Join/Single/2/3/4] **2: enter**

4. Enter a configuration option [Horizontal/Vertical/Above/ Below/Left/Right] <Right>: **enter**

Your screen will look something like the figure in the next page with four views in one AutoCAD drawing

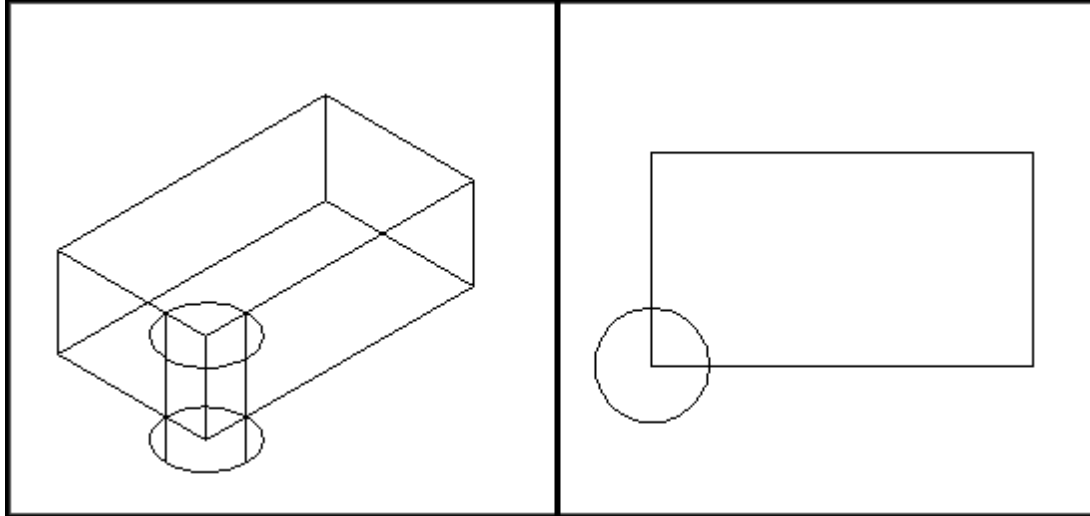

- **3D Face Invisible Edge:**

With 3DFACE, you control which edges of a 3D face are visible, allowing accurate modeling of objects with holes. Entering “i” or invisible before the first point of an edge makes the edge invisible. Type 3DFACE at the command prompt.

1. Type 3DFACE at the command prompt.

Command: 3Dface

First point: P1

Second point: P2

Third point: i P3

Fourth point: P4

Third point: i P5

Fourth point: P6

Third point: P7

Fourth point: P8

Then enters

Note: You must enter an “i” for invisible before the face shown next.

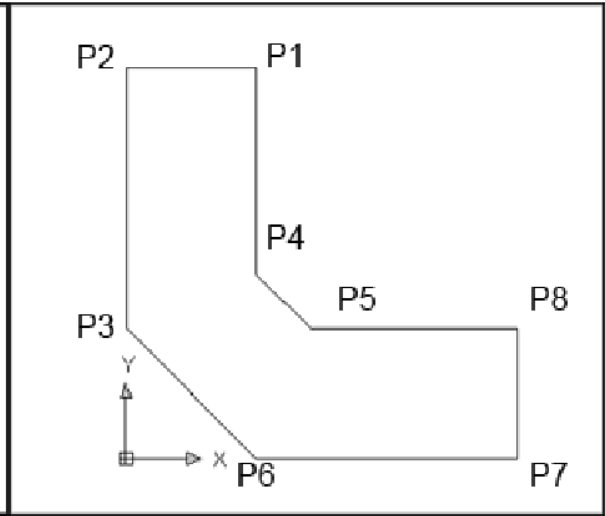
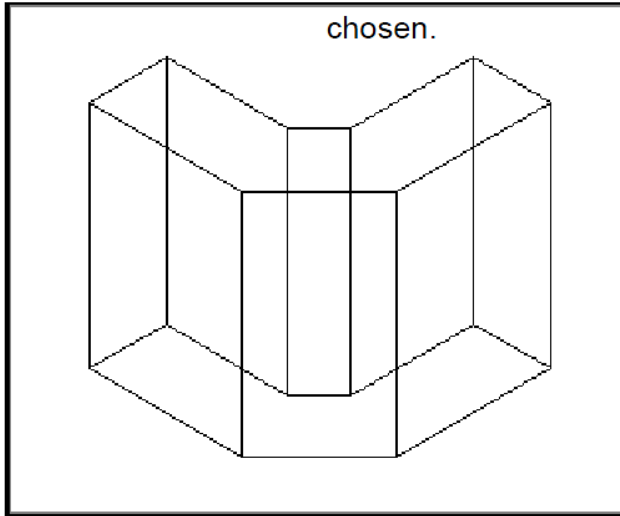

015

- **Union:**

1. Draw the following figure

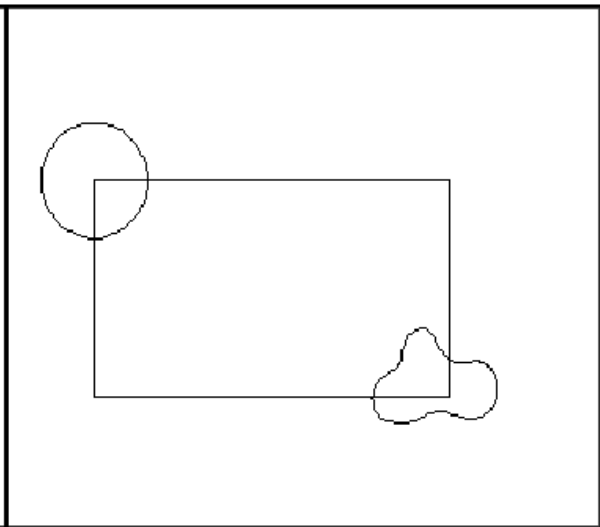
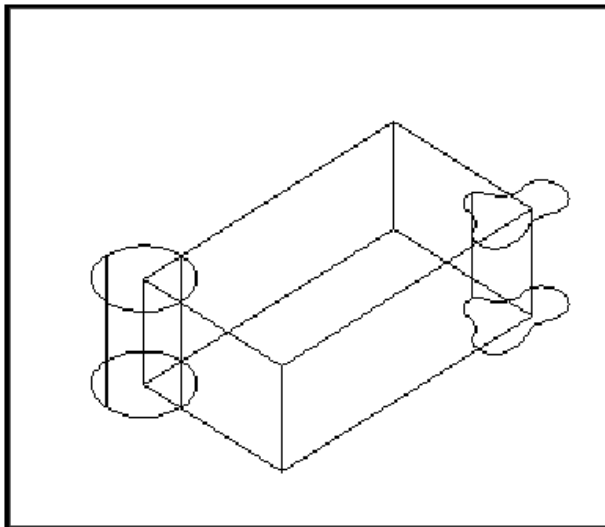

2. Choose Modify, Solids Editing, Union.
3. Type union at the command prompt.  
Command: union
4. Select objects: pick objects to union
5. Select objects: enter

Solid Objects Unioned Together

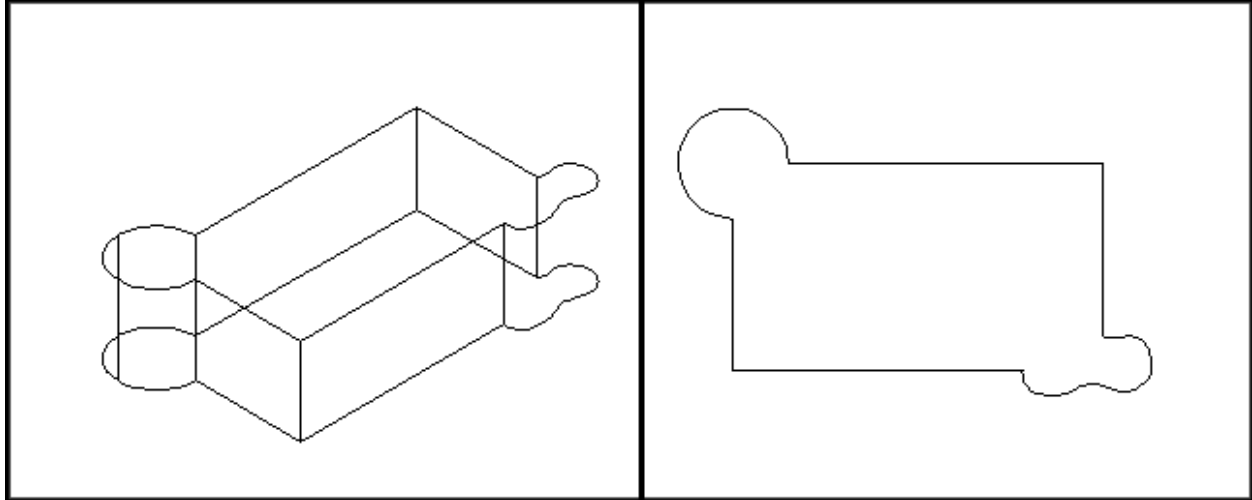

- **Subtract:**

1. Draw the following figure

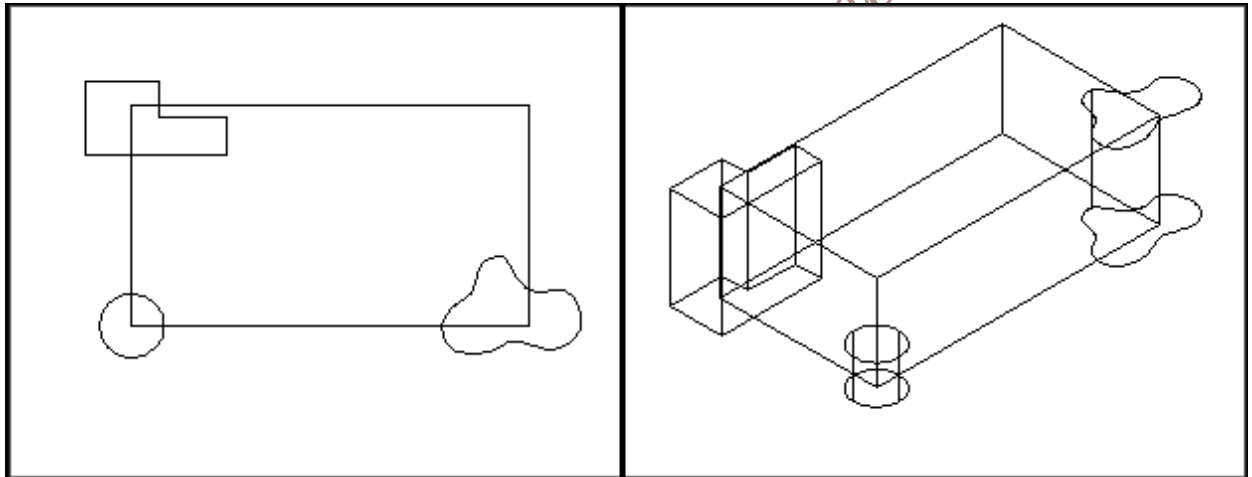

2. Choose Modify, Solids Editing, Subtract.

or

Type subtract at the command prompt.

Command: subtract

3. SUBTRACT Select solids and regions to subtract from

4. Select objects: pick the box

5. Select objects: (press enter)

6. Select solids and regions to subtract... Select objects: pick the cylinder, and other objects

7. Select objects: (press enter)

Objects Subtracted from Box

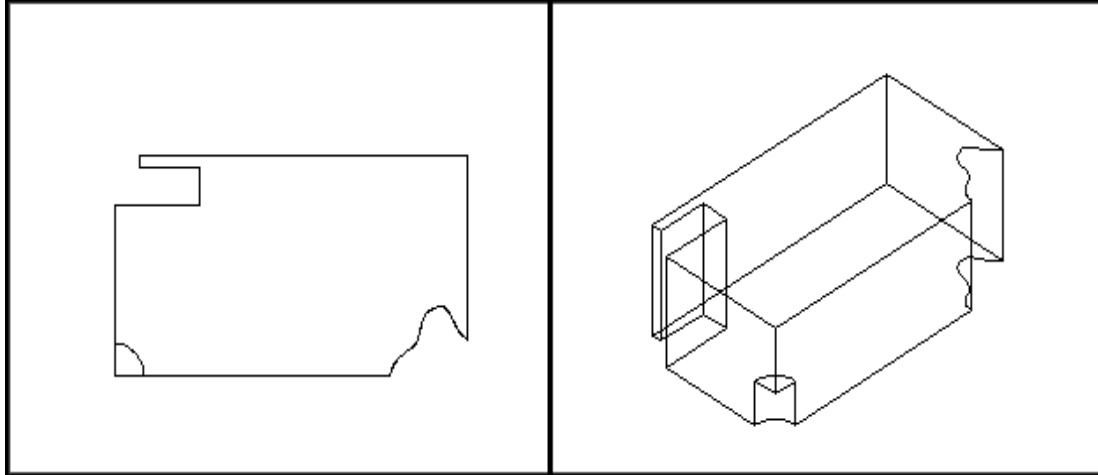

**- Intersect:**

1. Draw the following figure

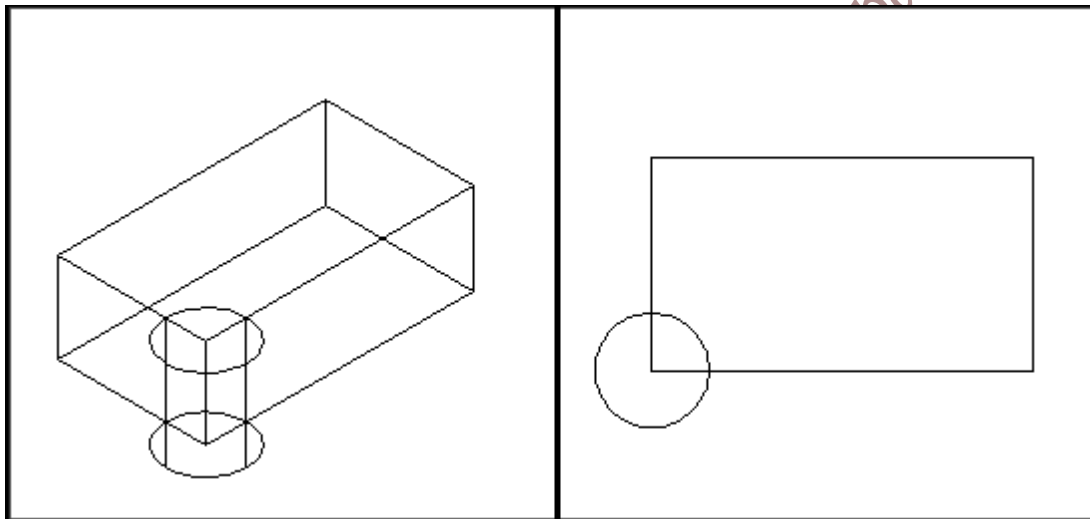

2. Choose Modify, Solids Editing, Intersect

or

Type intersect at the command prompt.

Command: `intersect`

3. Select objects: pick objects

4. Select objects: enter

Intersection of Cylinder and Box



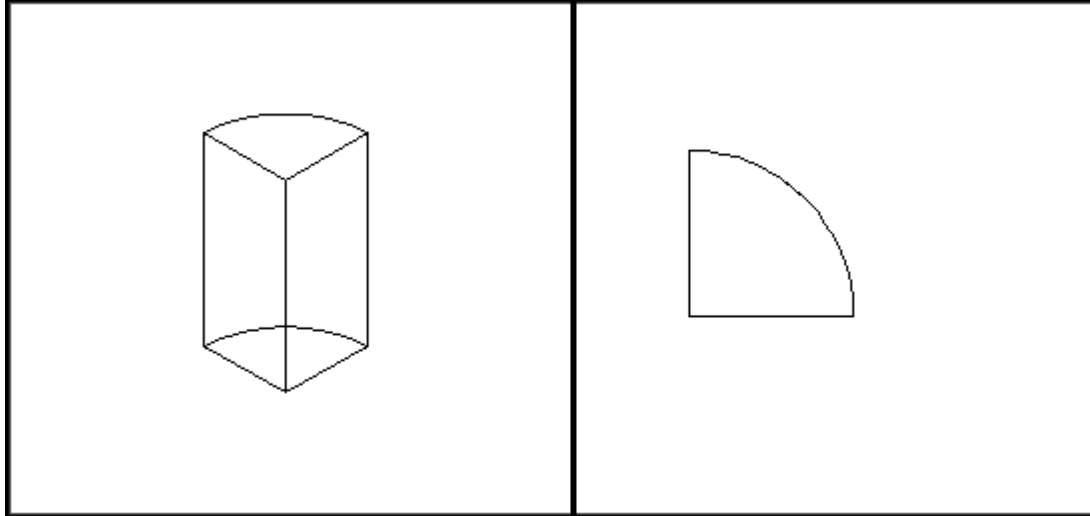

- **Thicken:**

Creates a 3D solid by thickening a surface.

1. Draw the following figure

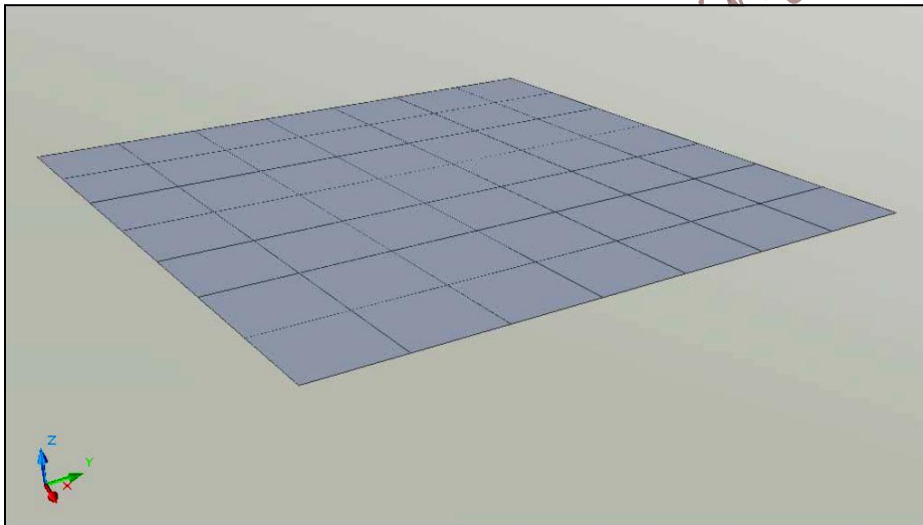

2. Choose Modify, 3D Operation, Thicken.

or

Type thicken at the command prompt.

Command: thicken

3. Select surfaces to thicken: 1 found

4. Select surfaces to thicken:

Specify thickness <0.0000>: 1

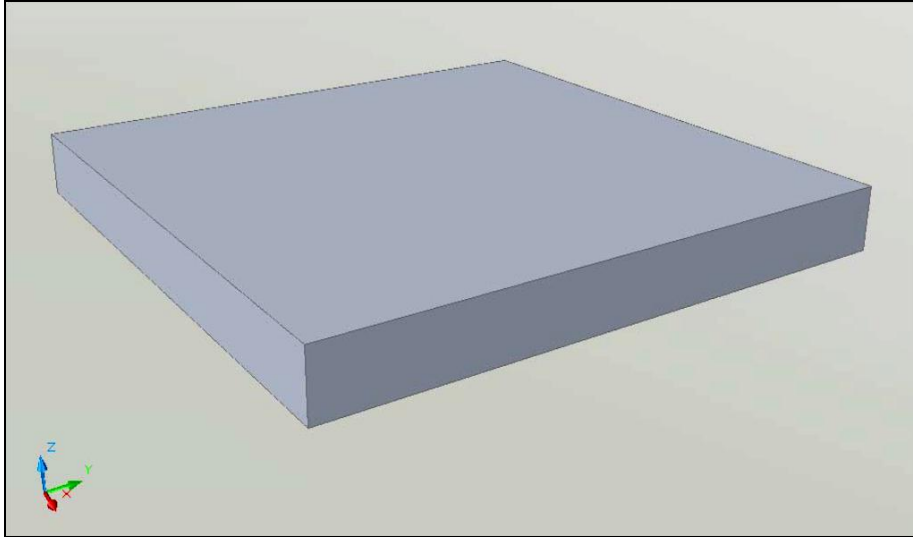

- **Extrude Face:**

1. Draw the following figure

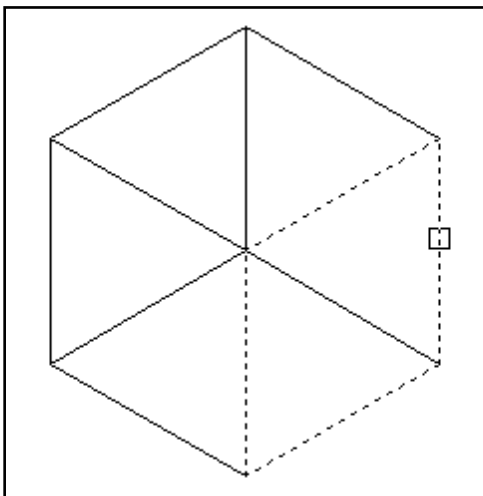

2. Choose Modify, Solid Editing, Extrude face.

NOTE: Must be a solid to extrude the face.

3. Choose a face to extrude. If you choose more than one face, hold the SHIFT key to deselect unwanted faces.

4. Press ENTER.

5. Specify height of extrusion or [Path]: .25

6. Specify angle of taper for extrusion <0>: 45

Extruded Face:

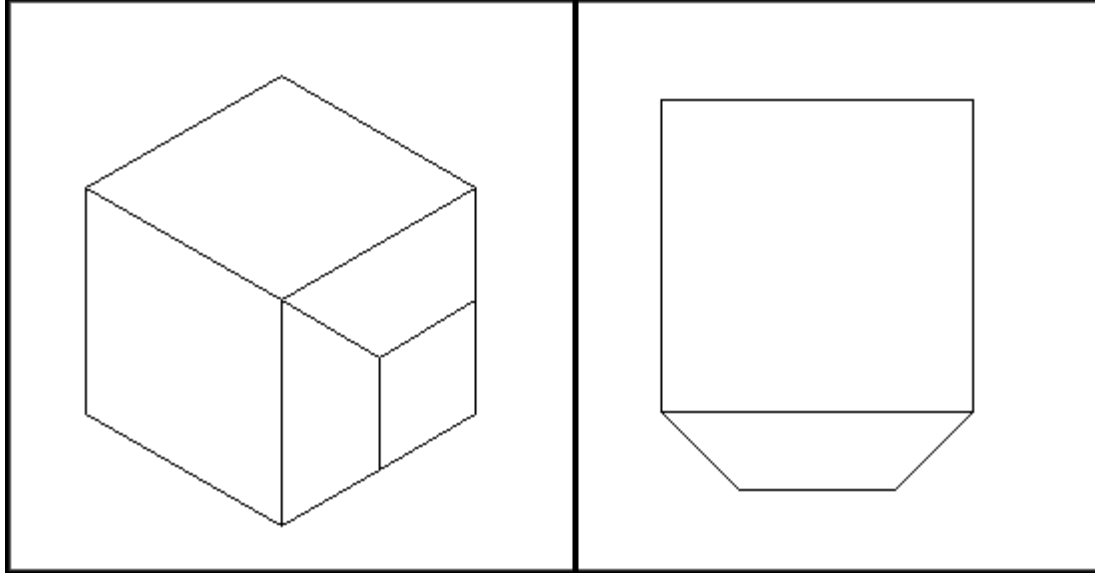

**Delete Face:**

1. Draw the following figure

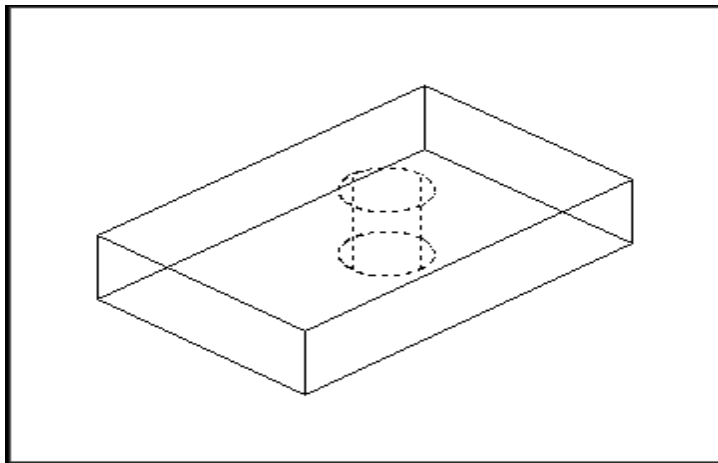

2. Choose Modify, Solid Editing, Delete face.
3. Choose a face to delete. If you choose more than one face, hold the SHIFT key to deselect unwanted faces.
4. Press ENTER.
5. Choose the face to delete.

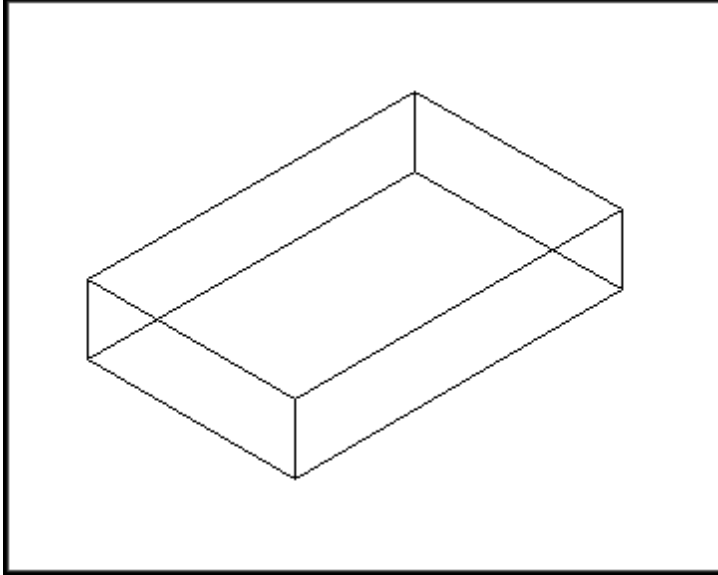

- **Copy Face:**

1. Draw the following figure

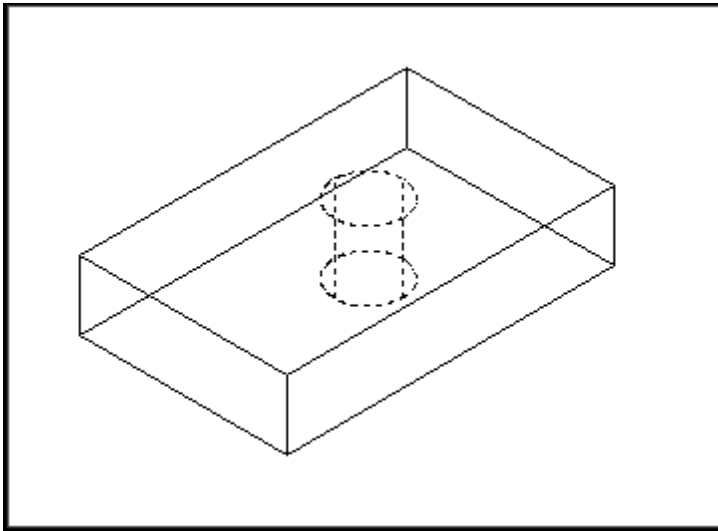

2. Choose Modify, Solid Editing, Copy face.
3. Choose a face to copy. If you choose more than one face, hold the SHIFT key to deselect unwanted faces.
4. Press ENTER.
5. Pick the solid face to copy.
6. Pick a new location

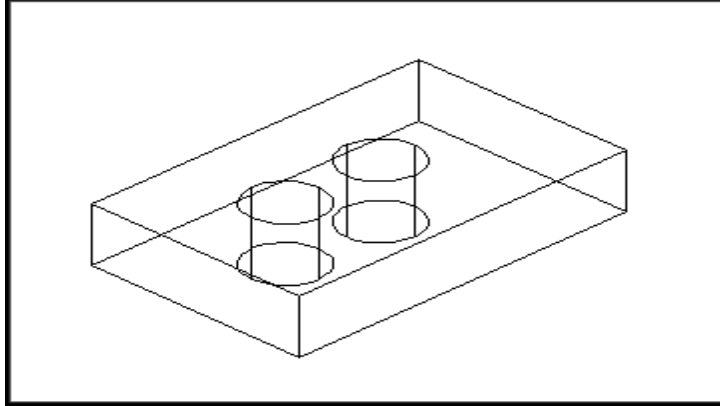

➤ **Procedure:**

➤ **PARTA:2D Drawing:**

1. Click  ➤ New.
2. Save your file as ➤ Drawing6\_A.dwg.
3. Draw the three sides of the following object as shown in Figure 6.1

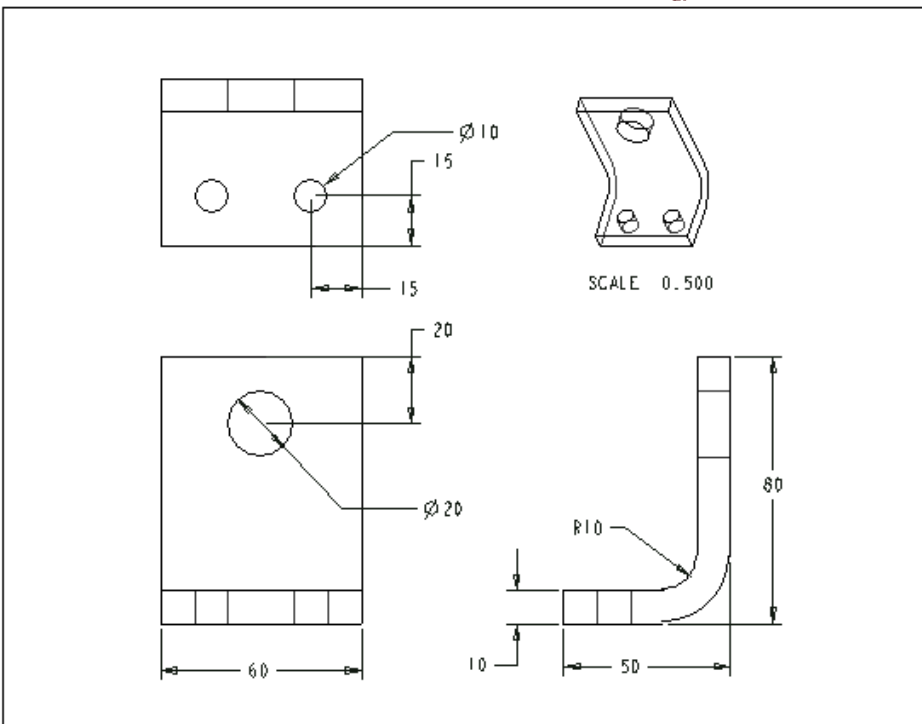



Figure 6.1

4. Set the dimensions as shown in Figure 6.1.
5. Save the changes in your drawing.

➤ **PARTB:**

2. Click  ➤ New.
3. Save your file as ➤ Drawing6\_B.dwg.

➤ **Create 3D Solid Primitives:**

You can use standard 3D solid objects known as solid primitives to create a box, cone, cylinder, sphere, torus, wedge, and pyramid. To create these 3D solid primitives, switch the workspace to 3D Modeling, where the palettes and ribbon panel are customized to create and modify 3D solid models.

- **Switch to the 3D Modeling Workspace:**

1. On the status bar, at the bottom of the drawing area, click the Workspace Switching button.



2. On the Workspace menu, click 3D Modeling.

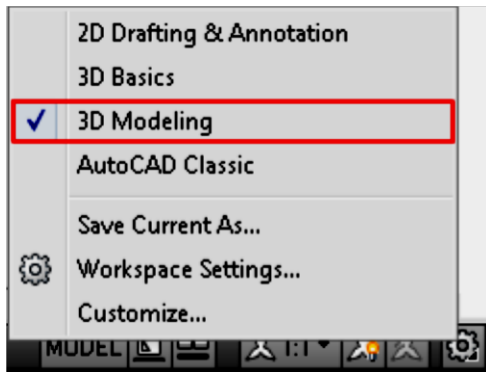

The 3D Modeling workspace is displayed. In this workspace, you can access the various commands and tools needed for creating 3D drawings

- **Viewports:**

5. Draw the following figure

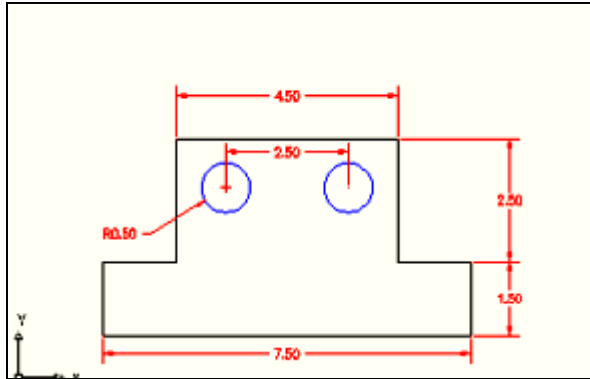

Figure 6.2

6. Type -VPOR TS at the command prompt.

Command: **-VPOR TS**

7. Enter an option [Save/Restore/Delete/Join/Single//2/3/4]: 4

**enter**

8. Enter a configuration option [Horizontal/Vertical/Above/ Below/Left/Right] <Right>: **enter**

Your screen will look something like the figure below with four views in one AutoCAD drawing.

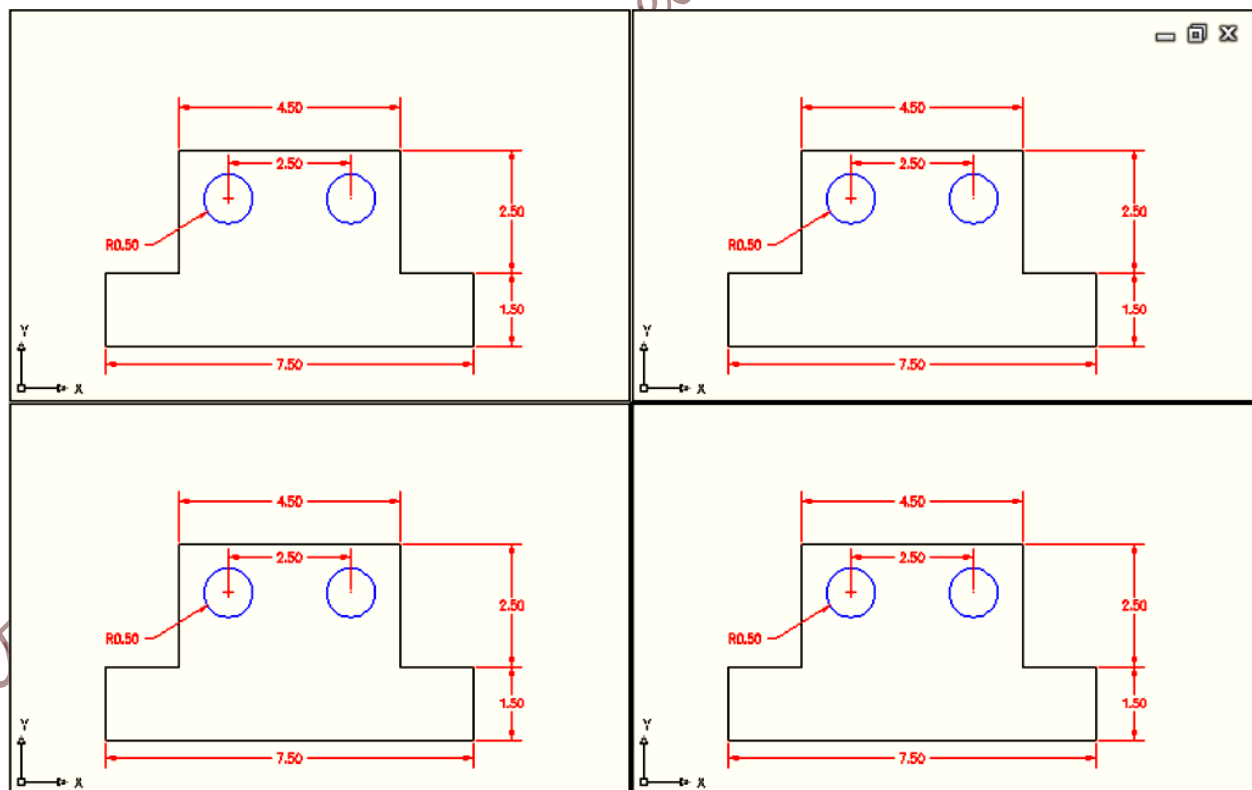
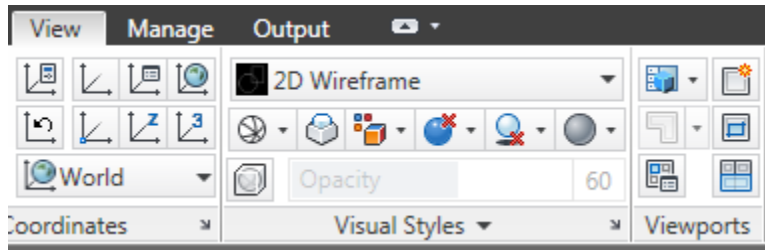

Figure 6.3

- **Thickness Command:**

1. Begin a new drawing using a 3D Modeling workspace.
2. Choose View, Viewports, 2 Viewports.



3. Press ENTER for the default of two vertical viewports.
4. Type THICKNESS at the command prompt.  
Command: thickness
5. Enter new value for THICKNESS <0.0000>: 3
6. In the plan view, draw a rectangle using the LINE command.

The lines will have a 3D “thickness” that can be seen in the 3D view of Figure 6.4

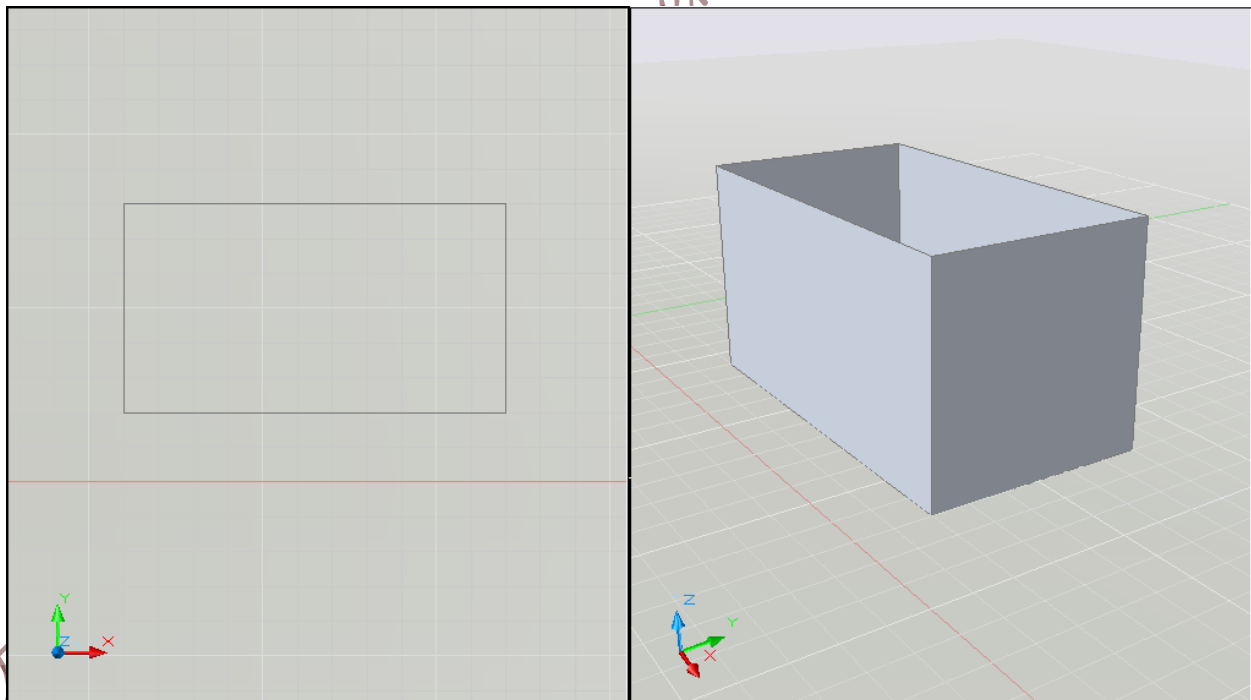
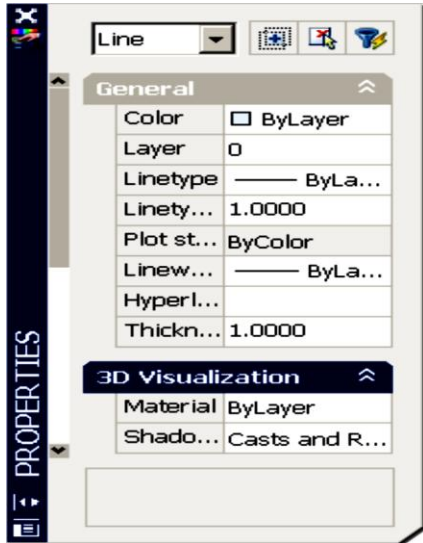

Figure 6.4



- **Change An Existing Thickness:**

1. Select the object whose thickness you would like to change (e.g. one line of the rectangle you drew in Figure 6.4).
2. Choose Modify, Properties...or right click and choose Properties...
3. In the Properties dialog box type a new line thickness.



The following result is a new line thickness for the selected object

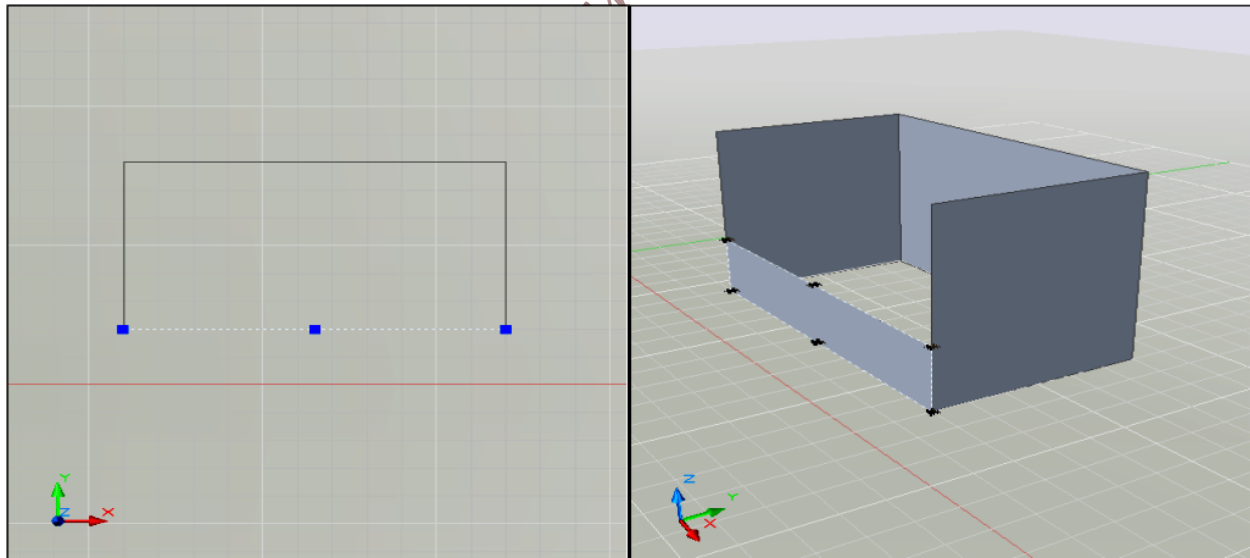

Figure 6.5

- **Elevation:**

1. Type ELEVATION at the command prompt.

Command: elevation

2. Enter new value for ELEVATION <0.0000>: 1.00

3. Draw two circles at the new elevation. Note that they appear to be “floating” 1 unit above the ground.

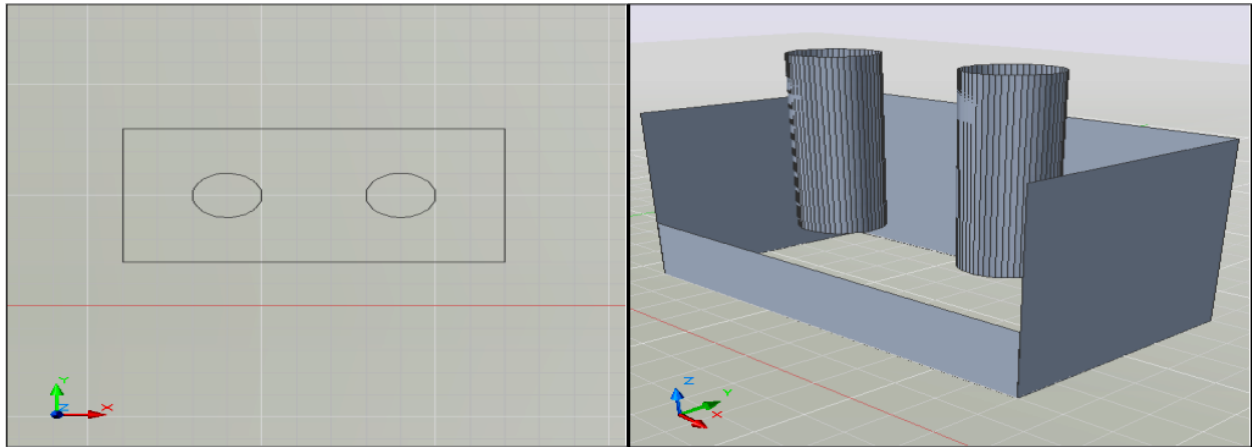



Figure 6.6

➤ **PARTC: Creating Simple 3D Objects from 2D Objects:**

You can create simple and complex objects by combining and modifying basic 3D shapes. You can also extrude 2D objects to create solids and surfaces by adding height. If you extrude a closed object such as a circle, the result is a 3D solid. If you extrude an open object such as an arc or a line, the result is a surface. A surface is a type of 3D object, that has no thickness.

**Drawing a table stand with simple 3D solid primitives:**

1. Click  ➤ New
2. Draw the following figure

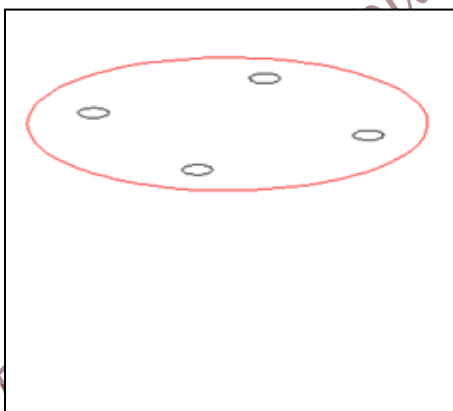
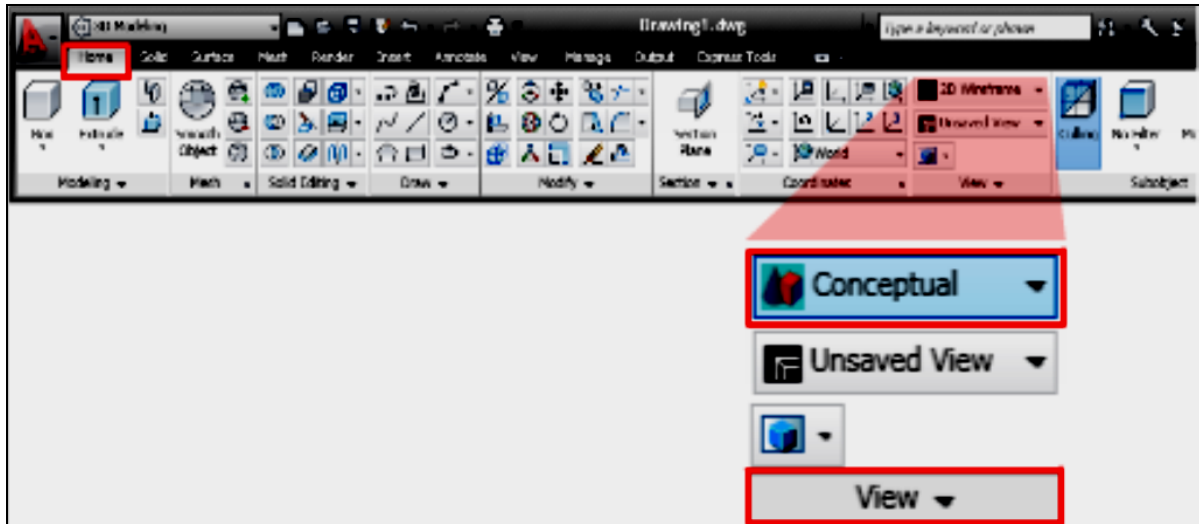

Figure 6.7

3. On the ribbon, click Home tab ➤ View panel ➤ Visual Styles drop-down list ➤ Conceptual.



4. On the left half of the status bar, click the Object Snap button to enable object snap mode. Right-click the Object Snap button.



5. On the shortcut menu, click "Center" to turn it on. The Center option should now have a box around its icon which indicates the object snap is enabled.

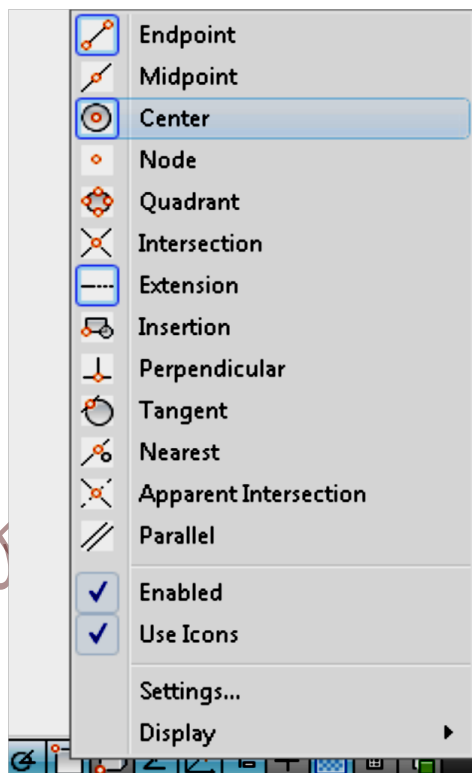

6. On the ribbon, click Home tab > Modeling panel > Solid Primitives drop-down > Cone. 
7. At the prompt, move the cursor over one of the smaller circles. The center point of the circle is displayed. Click the center of the circle in the drawing.

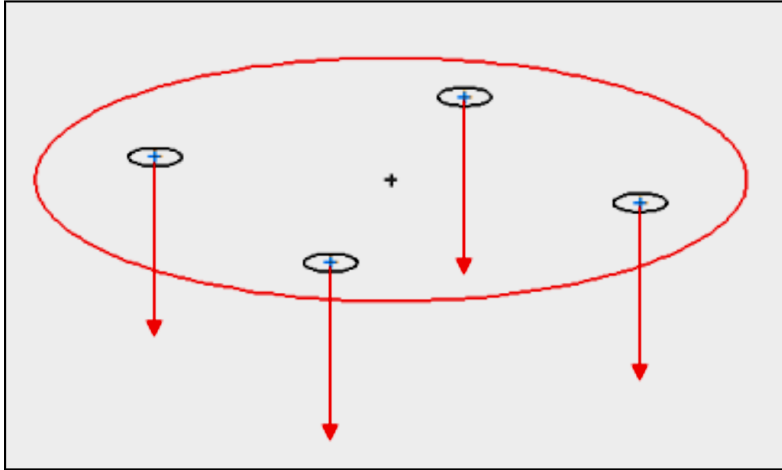

Figure 6.8

8. At the prompt, enter T for top radius and press Enter
9. At the prompt, enter 0.5 for radius and press Enter
10. At the prompt, enter -4 for height and press Enter
11. From the properties of cone, change the base radius from 0 to 0.3.
12. Repeat the process for the other smaller circles in the drawing to create Four-table legs

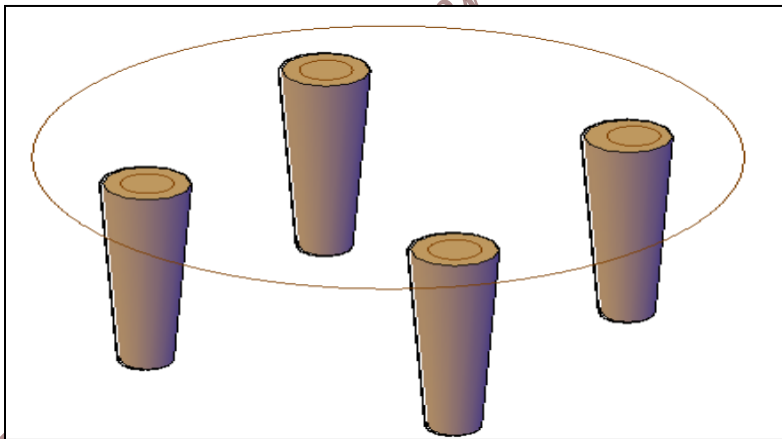



Figure 6.9

You have created four legs for the table

- **Draw a table top with simple 3D solid primitives**

In the same drawing file, do the following:

1. On the ribbon, click Home tab > Modeling panel > Solid Primitives dropdown

> Cylinder. 

2. At the prompt, select the center point of the circle that has a radius of 4

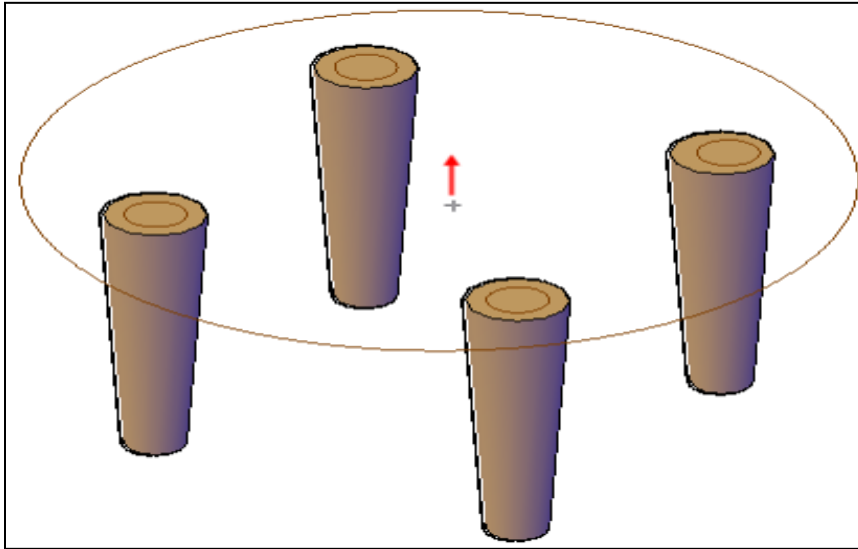

Figure 6.10

3. At the prompt, enter 4 for radius and press Enter.
4. At the prompt, enter 0.5 for height and press Enter.

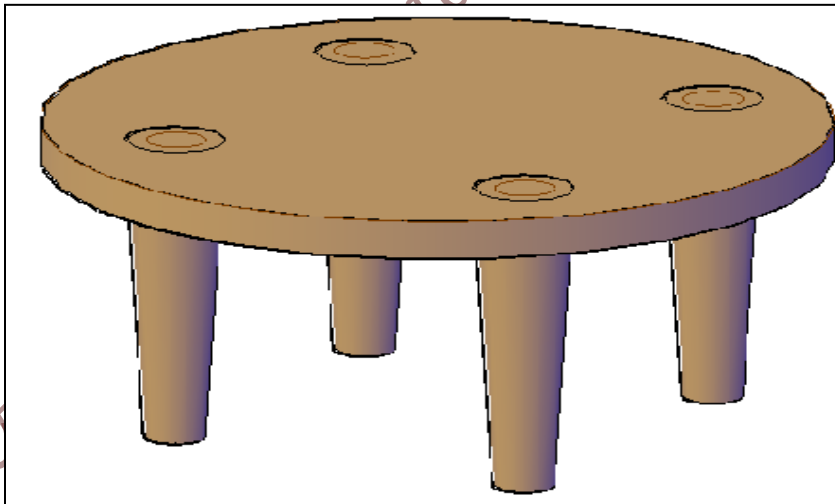



Figure 6.11

You have created a table top.

- **Extrude an object to create the walls of a room:**

1. Click  > New
2. Draw the following figure

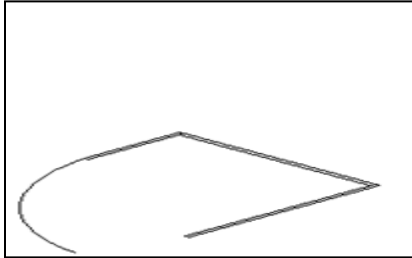
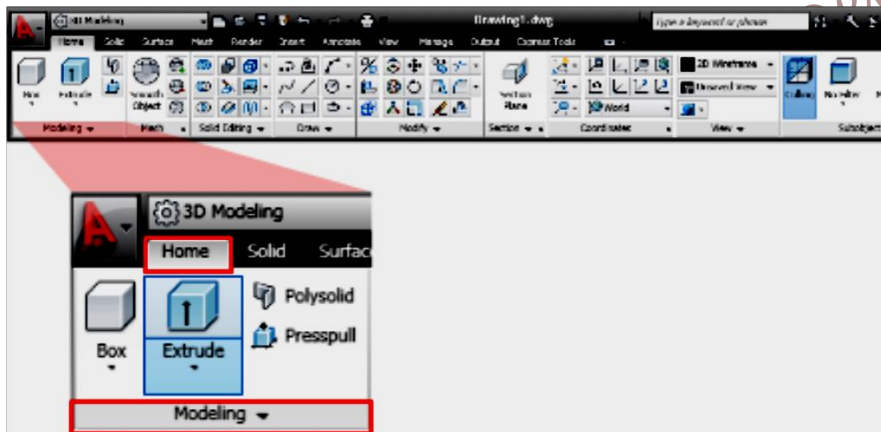

Figure 6.12

1. On the ribbon, click Home tab > Modeling panel > Solid Creation drop-down > Extrude.



2. At the prompt, select the three closed rectangles in the drawing window, and press Enter.

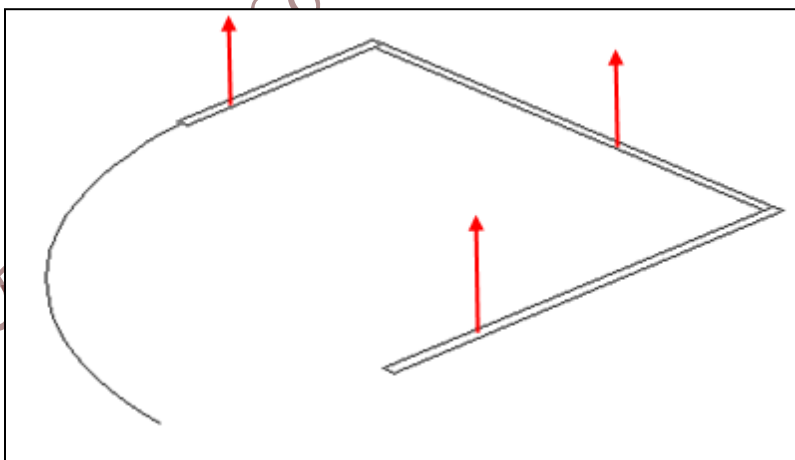

Figure 6.13

3. At the prompt, enter 96 for the height of extrusion and press Enter.
4. Repeat the extrude process on the arc (open object) displayed in the drawing to create a 3D surface.

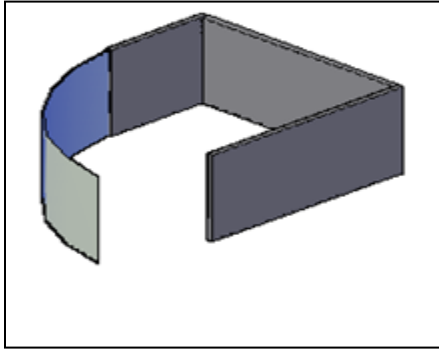
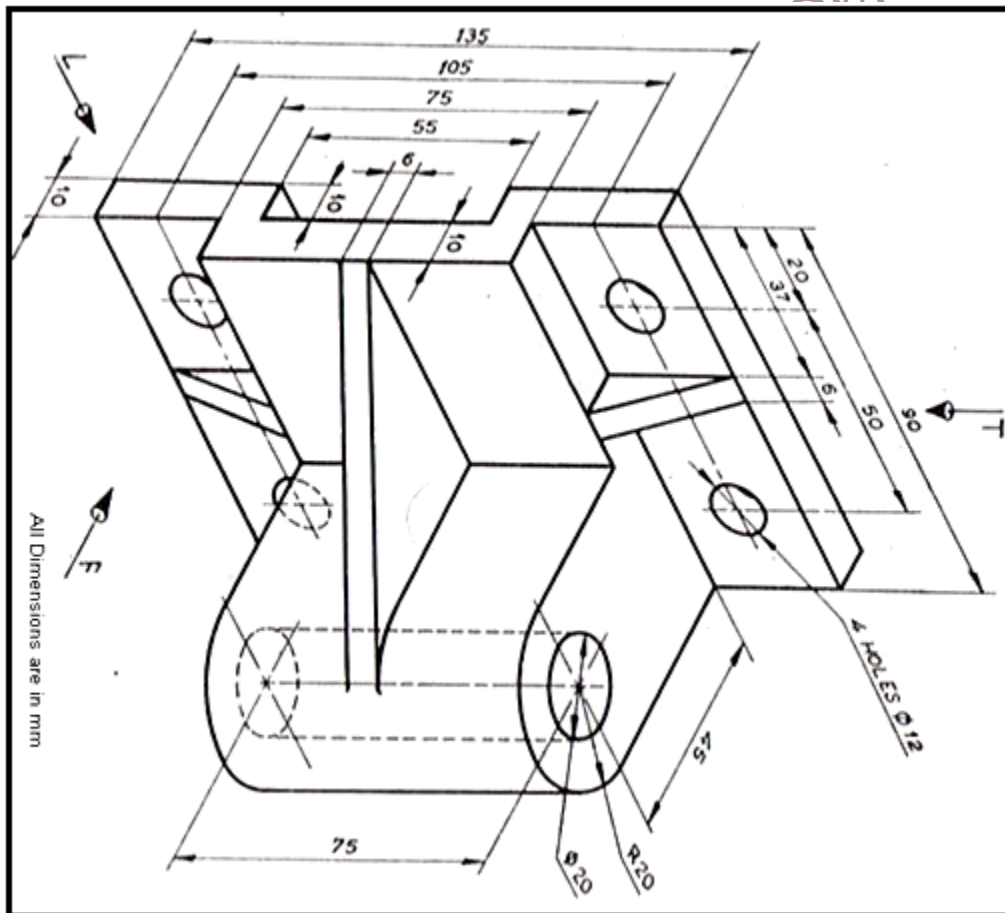

Figure 6.14

➤ **Exercise:**



*Electrical and Computer Engineering Department-BZU, 2015*



## Experiment # 7

### Introduction to Electrical Installation Components

#### ➤ **Objectives:**

The main objectives of this experiment are:

1. To be introduced to various components used in domestic electrical installations
2. To be introduced to various tools used in domestic electrical installations
3. To be introduced to various types of wires and cables used in domestic electrical installations
4. To be introduced to various types of protection elements (MCBs and RCDs) used in electrical installations
5. To become familiar with the circuit connection of various types of switches and timers
6. To be introduced to power circuit components
7. To be introduced to some types of luminaries

#### ➤ **Introduction:**

##### **I) Tools:**

Pliers, Pair of cutters, Testers, screw drivers, flexible springs, etc.

- A) **Pliers:** are hand held tools used to pull wires or hold small components and objects firmly. They have isolated handles.



- B) **Pair of cutters:** are used to cut and/or to peel (to strip) wires insulator. They have isolated handles.



C) **Tester:** is used to check the presence of the power supply. There are many types of testers available; testers with an indication light, testers with an LCD, or even wireless testers, as shown in the figures below.

1) Tester with light indicator



2) Tester with LCD



3) Wireless tester



D) **Screw drivers:** to screw and unscrew screws



E) **Fish-tape or light (flexible) string:** is used to run or fish wires in conduits, pipes and tubes.



## II) Wires

Wires of various cross sectional areas and colors are used in lighting, extra low voltage and power circuits. Table 1 shows the wires cross sectional areas, the recommended protection fuse or Miniature Circuit Breaker (MCB) current ratings, and typical application circuits. On the other hand, Table 2 shows the color code used generally in wiring circuits. More details about the wires and cables can be obtained from standard tables; an example is shown in Table 3 for single core wires of 650V rating.



Table 7.1: wires cross sectional areas, protection fuse or MCB rating, and typical applications

Wire's cross sectional area [mm <sup>2</sup> ]	Rated current of protection fuse or Miniature Circuit Breaker [A]	Application
0.5	4	Extra low voltage circuits
1.5	10	Lighting circuits
2.5	16	Power circuits
4	20	Heavy heating and cooking loads
6	32	Main supply for single phase loads
10	40	In three phase circuits

Table 7.2: Color code for wiring circuits

Wire colors	Application
Brown (or Red)	Phase or the Line conductor
Blue (or black)	Neutral conductor
Yellow with Green stripes	Earth/Ground
Violet, Green, Brown with Black stripes, or other colors	Strapper or traveler conductors

Table 7.3: Specifications of single core wires of 650V rating

Cond. Area Sq. mm	Conductor Construction No./ Dia	Max. DC Conductor Resistance at 20°C in ohm / km		Unsheathed Cables		Sheathed Cables			Current Rating Amp	
		Copper	Aluminum	Insulation thickness	Overall Diameter	Insulation thickness	Sheath thickness	Overall Diameter	Copper	Aluminum
				Nominal mm	Approx mm	Nominal mm	Nominal mm	Approx mm		
1	01/01/12	17.7	-	0.7	2.6	0.6	0.8	4.1	10	8
1.5	01/01/38	11.9	19.7	0.7	2.9	0.6	0.8	4.4	13	10
2.5	01/01/78	7.14	11.8	0.8	3.5	0.7	0.8	5	20	15
4	01/02/24	4.47	7.39	0.8	4	0.8	0.9	5.85	26	20
6	01/02/76	2.97	4.91	0.8	4.5	0.8	0.9	6.4	35	27
10	01/3.55 Al	01/08/09	2.94	1	5.7	1	0.9	7.55	44	34
	7/1.35 Cu	-	-	-	6.2	-	-	8.05	45	35
16	07/01/70	1.13	1.87	1	7.2	1	1	9.3	55	43
25	07/02/14	0.71	1.18	1.2	8.9	1.2	1.1	11.2	75	58
35	07/02/50	0.51	0.85	1.2	10	1.2	1.1	12.3	90	70
50	07/3.00	0.38	0.63	1.4	11.9	1.4	1.2	14.4	120	92
	19/1.78	-	-	-	11.9	1.4	1.2	14.4	120	92
70	19/2.14	0.26	0.44	1.4	13.6	-	-	-	150	116
95	19/2.50	0.19	0.31	1.6	15.8	-	-	-	175	135
120	02/03/37	0.15	0.25	1.6	17.5	-	-	-	200	155
150	02/24/37	0.12	0.2	1.8	19.4	-	-	-	230	175
185	37/2.50	0.1	0.16	2	21.7	-	-	-	265	205

### Terminal blocks

Terminal blocks are used to connect single core wires together. They are usually supplied in 12-way lengths as shown in the figure next, but they can be cut into smaller blocks with a sharp knife or large wire cutters. They are sometimes called 'chocolate blocks' because of the way they can be easily cut to size.



### III) Meters and Circuits Breakers

- a) **KiloWatt-Hour (kWH) meter:** is an energy meter designed to measure the number of kilowatt-hours of energy consumed. It has digital readouts or dials. The reading of the kWH is proportional to I, V, pf and time. The reading represents the consumed energy. Connection of the kWH meter depends on the manufacturer and its datasheet should be

revised. Examples of kWh meters and their possible connections are shown in the figures next page.

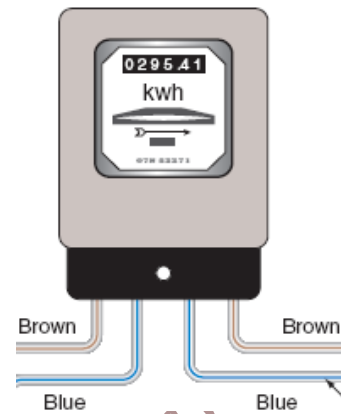
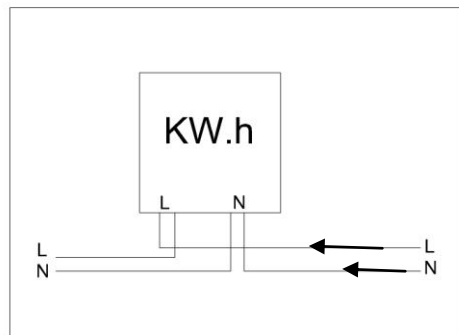

52U, 2015

**b) Miniature Circuit Breaker (MCB):**

It disconnects the circuits if the current is greater than its preset value. They protect the circuit against overload and short circuit currents. The commonly-available preferred values for the rated current are: 6A, 8A, 10A, 13A, 16A, 20A, 25A, 32A, 40A, 50A, 63A, 80A, 100A...



**c) Earth Leakage (EL) or Residual Current Device (RCD):** E.L.

It detects any leakage current by comparing the current in the phase with that in the neutral. It has the phase and the neutral connected directly to and out of it. Usually, it operates when the difference between both currents exceeds 30mA. It has a test button [T] to have the functionality of the device checked periodically.



**d) Distribution Board (DB)**

It is a box made of PVC or other polymers located in an accessible location within the flat/house. It includes the Main MCB, EL or RCD, timers, and all other MCBs. It has also three bus-bars; one for the phase, a second for the neutral and the third for the earth. An example of a DB is shown in the next figure.



#### IV) Timers, Electrical Bell, and Switches

##### 1. Timers

- They are used for control lighting of a stair case.
- They are used to keep a device on/off for a preset time.
- The connection depends on the type of timer used
- The time is set for seconds up to few minutes, e.g. 1-7 minutes
- Usually, the push buttons and lamps have direct connection to the neutral conductor.

**Considering the specifications of Schneider Timers controlling a Stair case lighting:**  
They have various selectors for different settings:

**Selector (1):** For the selection of wiring configuration of lamps and push buttons. The figures below show the connections when the selector is set to position 3 or position 4. Position 3 configuration will be used in the Laboratory experimentation. Further information is found in the datasheet.

**Selector (2):** A. permits the control of light for adjustable period (1 to 7 minutes) by the time delay setting (selector (3))  
B. continuous light is possible.

**Selector (3):** Adjusts time delay setting

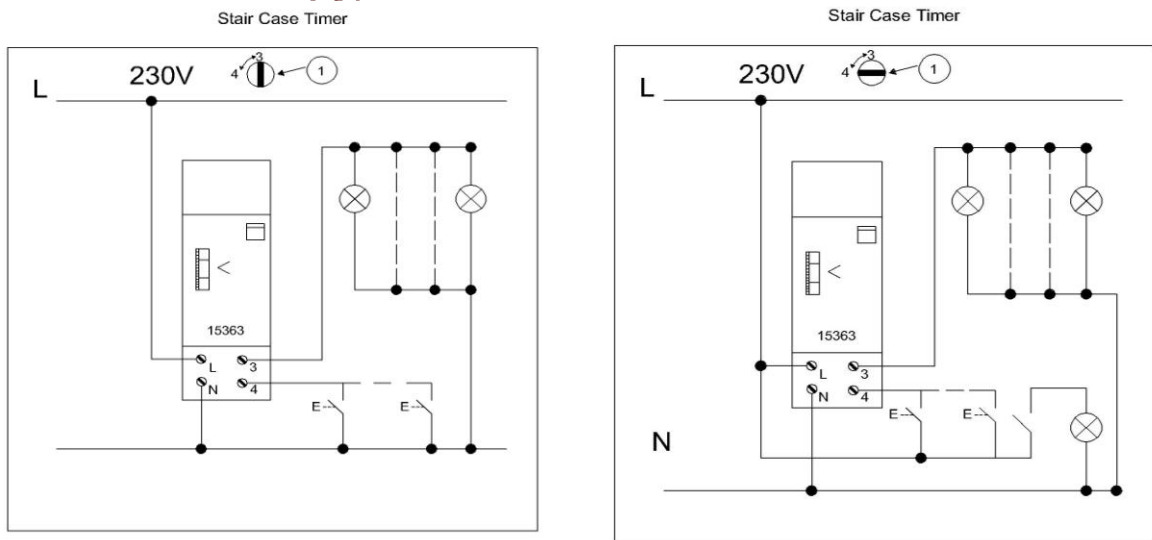

## 2. Electric Bell:

Every house or flat has an electric bell or an intercom installed. An example of PIN configuration of an electric bell is shown in the figure next.

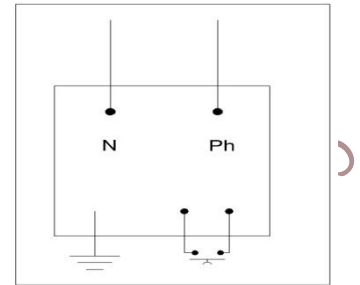

## 3. Single pole switch:



It has on and off states as shown in the figure next.

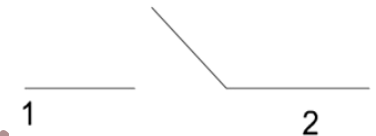

## 4. Gang switch:



It can switch more than one light individually. A double (two circuit) switch is shown in the next figure. The number of cross bars on the symbol indicate the number of circuits the switch can control; in this case it's 2.

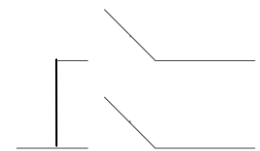

## 5. Double pole switch:



It disconnects both the line and the neutral by a single throw, and it has an indication lamp. It is used for heater control. A typical PIN configuration of the switch is shown in the figure next.

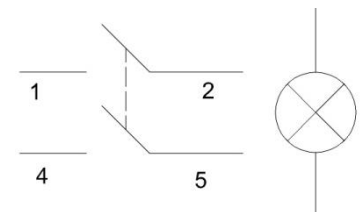

## 6. Two-way switch:



It provides two possible ways of current flow and is used in circuits to control a luminary from more than one location. A typical PIN configuration of the switch is shown in the figure next. Possible connections are: 1-2 or 2-3; pin 2 is common.

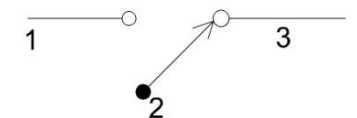

**7. Intermediate switch (cross switch):** 

It is used with 2 two-way switches to control a luminary from more than two locations. A typical PIN configuration of the switch is shown in the figure next. Possible connections are: (1-5 & 2-4) or (1-2 & 4-5).

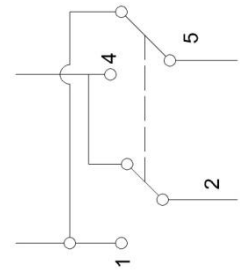

15

**8. Push button:** 

It is closed as long as it is pressed; it opens when it is released. It is used in timer controlled circuits, or in circuits with hold-on facility. A typical PIN configuration of the switch is shown in the figure next.

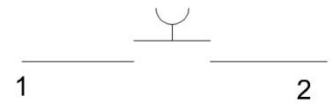

**9. Dimmer switch:**

It is a switch used to control the light intensity of a Luminary by supplying it with a portion of the input voltage. It is connected in series with the luminary in the phase conductor.

**V) Power Socket Outlet:**

- The power socket outlet has 3 PINs. The rear view of the socket outlet is shown in the figure next. It is clear that line or phase is connected to the left PIN, the neutral is connected to the right PIN, and the earth is connected to the middle-lower PIN.
- Water proof sockets are installed on ceramics, tiles, stonewalls, fair faces, bathrooms or outdoors; i.e. in any place subject to water or moist.

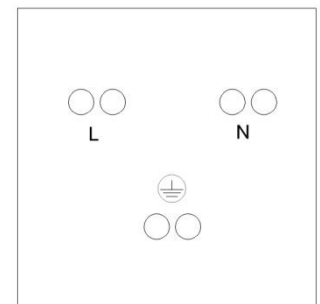



- Usually, 2.5mm<sup>2</sup> single core cable (wire) is used in power circuits.
- At least two socket outlets are installed in every single room. However, the number of socket outlets depends on the room function, decoration, area, and consumer wish.
- The height of the socket on the wall is 60-80cm from the floor.
- The power circuits, lighting circuits and ELV circuits must be separated from each other.

## VI) Luminaries

The main types of luminaries used in domestic lighting are:

### A) Standard Incandescent lamps (Tungsten-filament lamps)

The main components of an incandescent lamp are marked on the figure below.

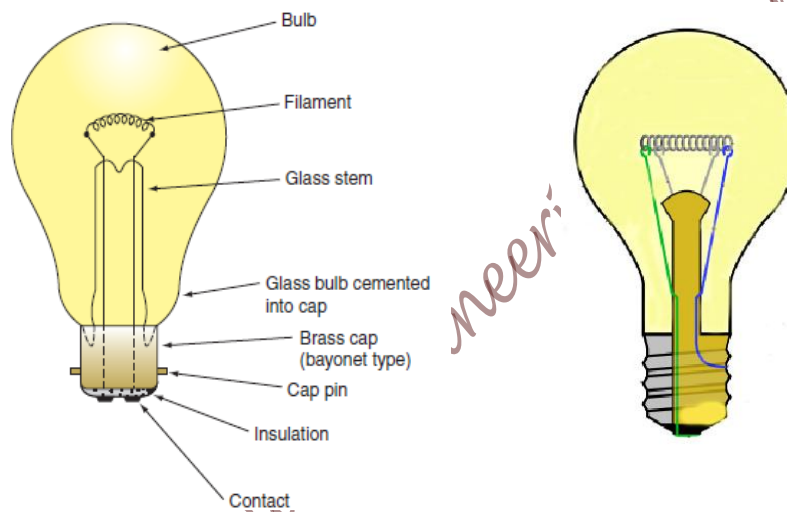

### B) Fluorescent lamps

- ❖ It consists of a glass tube, a choke, and a starter, as shown next:
- ❖ Glass tube is filled with Mercury vapor at low pressure and a little of Argon to assist starting.
- The interior of tube is coated in fluorescent Phosphor.
- Each end of the tube has an oxide coated filament.
- Discharge takes place when a high voltage is applied across the tube.

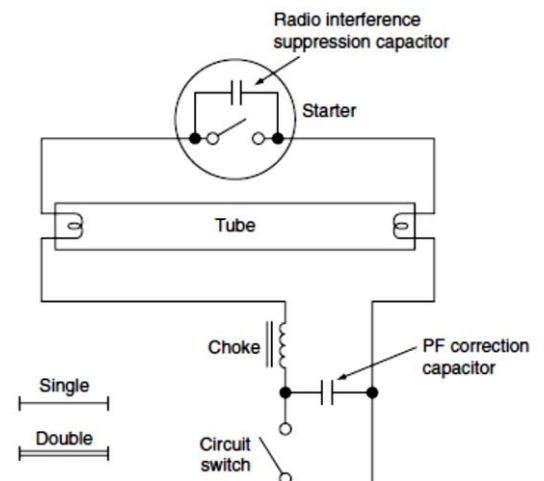

### Operation of Fluorescent lamps

- a) When the main switch is closed, the circuit is closed via the starter contacts.
- b) The filaments become warm and the oxide coated filaments emit electrons and gas ionizes at the ends of the tube (this helps main ionization).
- c) The starter contacts separate, and the choke is open circuited causing a high voltage to appear across the open contacts; the inductive energy is released in the form of an arc, and the energy dissipates via the gas.
- d) When the gas is fully ionized, the choke limits the current to a predetermined value.
- e) The light emitted, which is ultraviolet, is made visible by the fluorescent powder coating (the color depends on the mixture of Phosphor minerals; powder).

### **C) Compact Fluorescent Lamps**

Samples of these are shown in the figure next



#### ➤ **Experimental Activities**

In this experiment you will be introduced to the aforementioned items, and a demonstration will be given during the laboratory to explain how to deal with each element. Besides, you will get familiar with all components, mentioned in this handout, explore their function, and their terminals' connection. In addition, you will get familiar with all the aforementioned equipments and their use.

## Experiment # 8

### Distribution Board and Extra Low Voltage Installations

#### ➤ **Objectives:**

The main objectives of this experiment are:

1. To be introduced to various components used in domestic electrical installations
2. To become familiar with the connection of the kWh meter and Distribution Board
3. To become familiar with various types of protection elements (MCBs and RCDs), used in domestic electrical installations, against various types of faults
4. To become familiar with extra low voltage wiring; Telephone, Internet, Television and Electric Bell
5. To become familiar with installing controlled light by timers used for lighting stair cases

#### ➤ **Introduction:**

The power supplied to our homes by the electricity company is transmitted by Polyvinyl Chloride (PVC) cables; the conductors run inside. The current rating of the cable is set by the electricity company depending on the load demand. Usually, for ordinary homes a single phase cable of  $3 \times 6 \text{ mm}^2$  is used; i.e. the cable consists of 3 wires (phase, neutral and earth) each is of a cross sectional area of  $6 \text{ mm}^2$ . Its rated current capacity is 32A. However, most electricity companies set the maximum allowed current, drawn by a single phase load, to 25A by installing the appropriate Miniature Circuit Breaker (MCB). In a building or a complex, a three phase cable is installed feeding the power to the building's main distribution board, where the power will be distributed to all flats in that building using single phase  $3 \times 6 \text{ mm}^2$  cables. The cable is protected by a fuse (32A) installed by the electricity company in the building's main distribution board at the sending end of the cable. Usually, a 25A-MCB is also installed in the main distribution board.

Various types of protection are implanted to provide any electrical installations with the highest possible safety. Protection can be classified into two types:

**A. Protection against over currents:** over currents occur either by:

**i) Overload:**

Overload currents occurring in healthy circuits are caused by faulty appliances or by surges due to starting motors. In motor circuits, overload heaters and relays may be used for protection against overload currents.

**ii) Short circuit:**

Short circuit current: it is the current that flows when a “dead short” occurs between live conductors (phase to neutral for single and three phase systems, or phase to phase for three phase systems). When a short circuit occurs, the current may, for a fraction of a second, reach hundreds or even thousands of amperes.

Fuses or Miniature Circuit Breakers (MCBs) are used for protection against over currents.

**B. Protection against direct or indirect contacts:**

Direct contact: the contact of a person or livestock with live parts, which may result in an electric shock.

Indirect contact: the contact of a person or livestock with exposed conductive parts made live by a fault.

Earth Leakage (EL) or Residual Current Device (RCD) is used to protect against direct or indirect contacts. Noticing that, all metallic parts of all appliances must be framed, and must be connected to ground.

**Protective Devices:**

**a) A Fuse:** it is a device which carries a metal element, usually tinned Copper, that will melt and break the circuit when an excessive current flows; it acts as a sacrificial device to provide over-current protection. Thus, it forms the weakest link in a circuit and protects the circuit conductors from damage. Samples of fuses are shown in the figure below.



**b) A Miniature Circuit Breaker (MCB):**



It protects the circuit against overload and short circuit currents. The nominal (rated) current ( $I_n$ ) in is defined as the current that can be carried indefinitely by the device. An MCB disconnects the circuit if the current is greater than the rated value. The commonly-available preferred values for the nominal (rated) currents are: 6A, 8A, 10A, 13A, 16A, 20A, 25A, 32A, 40A, 50A, 63A, 80A, 100A...The rated current is marked clearly on the MCB housing.



The protective device must be able to break the high (short circuit) current without damage to its surroundings by arcing or overheating or scattering of hot particles. According to IEC, the MCB is assigned  $I_{cu}$  (for industrial) or  $I_{cn}$  (for domestic) to indicate the rated ultimate short circuit breaking capacity, which is normally given in  $kA_{rms}$ . According to British standards, the breaking capacity of MCBs is indicated by an "M" number; i.e. M3-3KA, M6-6KA, M9-9KA.

The operating current of the protective device is defined as the value of a current which will cause operation of the device (tripping) and depends on the nominal (rated) value and the device fusing factor. A Fusing factor is a figure when multiplied by the nominal current will indicate the operating current value. The Fusing factor is approximately 1.45.

**c) An Earth Leakage (EL) or Residual Current Device (RCD):**

It detects any leakage current by comparing the current in the phase with that in the neutral. It has the phase and the neutral connected directly to and out of it. Usually, it operates when the difference between both currents exceeds 30mA. The operating time is not more than 40ms at 150mA. It has a test button [T] to have the functionality of the device checked periodically.



## Other Components

- i) **KiloWatt-Hour (kWH) meter:** is an energy meter designed to measure the number of kilowatt-hours of energy consumed. It has digital readouts or dials. The reading of the kWH is proportional to I, V, pf and time. The reading represents the consumed energy. Connection of the kWH meter depends on the manufacturer and its datasheet should be revised. Examples of kWH meters and their possible connections are shown in the figures below. The left figure shows the connections of the kWH meter to be installed during laboratory tasks.

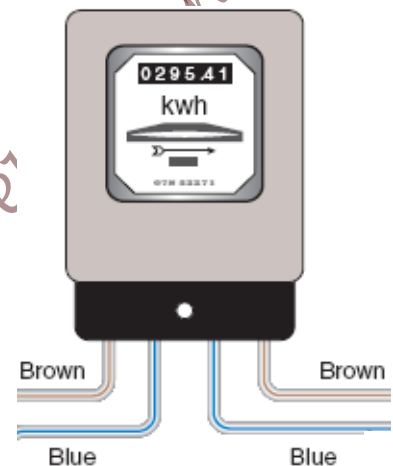
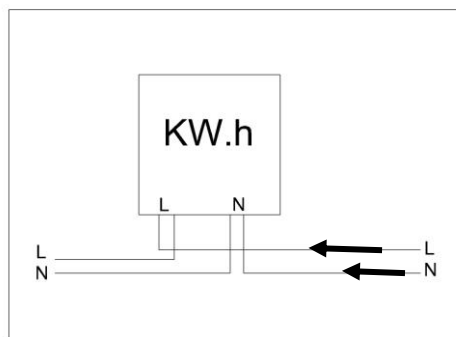

- ii) **Electric Bell**

An electric bell consists of electronic components which produce a buzz or a specified sound when a push button is pressed. The power supply for these components is fed from a step down transformer, which is connected directly to the mains. The transformer primary will be fed from an AC supply (220V) via 1.5mm<sup>2</sup> wires. An earth wire must be connected to the assigned ground terminal of the bell. A push button, located outside the flat, will be connected to the terminals assigned on the electric bell, as shown in the figure next. Two single core wires will run between the push button position and the location of the electric bell, inside the flat.

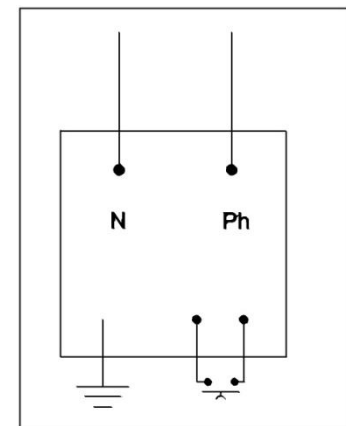

### iii) Timer

It is a relay which activates or deactivates pairs of contacts for a preset time by pressing a push button. Timers are used for controlling stair case lighting. The time is set for seconds up to few minutes. Usually, the push buttons and lamps have direct connection to the neutral conductor. The connection depends on the type of timer used. Hence, the manufacturer's datasheet should be revised and studied carefully. In this experiment, Schneider timers, when activated by pressing one of two push buttons, will be used to control the turn-on time of two lamps. Schneider timer terminals' configuration is shown in Figure 8.5.

### iv) Extra Low Voltage (ELV) Installations

These days, Telephone, Television and Internet installations are part of any domestic electrical installations. Despite the widespread of wireless technology, the wired systems are still in use and common. In this experiment, wiring of the three systems will be conducted and implemented in a symbolic flat. A socket for each system will be installed in the master bedroom. The wiring between the extra low voltage box and sockets will be exercised.

A Registered Jack socket (**RJ-45**) is used for internet (data) systems. Ethernet cables are connected and installed according to different wiring conventions. This means that the individual wires in the cable have to be connected in different orders to different sets of pins in the RJ-45 connectors. The table below differentiates between the different conventions used:

### Straight-through, Crossover, and Rollover Cable Types

Cable Type	Standard	Application
Ethernet Straight-through	Both ends T568A or both ends T568B	Connecting a network host to a network device such as a switch or hub.
Ethernet Crossover	One end T568A, other end T568B	Connecting two network hosts. Connecting two network intermediary devices (switch to switch, or router to router).
Rollover	Cisco proprietary	Connect a workstation serial port to a router console port, using an adapter.

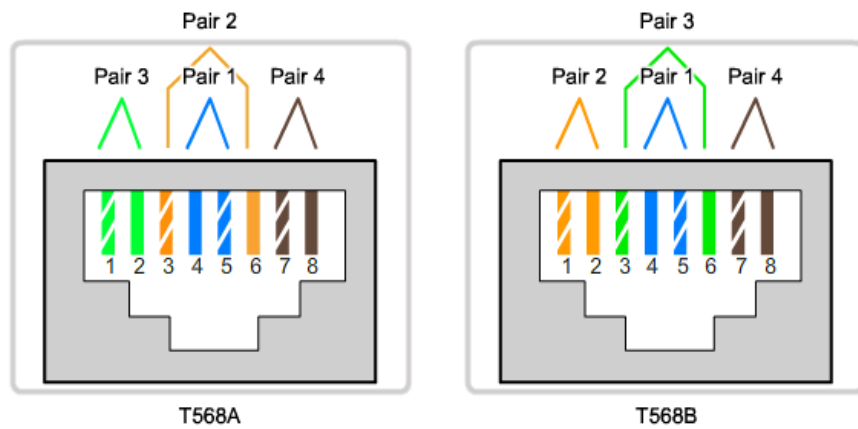

Connectors are frequently terminated using the T568A (TIA/EIA-568-A) or T568B (TIA/EIA-568-B) pin/pair assignments, depending on whether they are straight or cross connection. The figures below show male and female (RJ45) wiring. Comparing the male terminals of the figures below, it is clear that the copper connections and pairing are the same, the only difference is that the orange and green pairs (colors) are swapped. Note that the female connector or socket is of EIA/TIA 568B type.

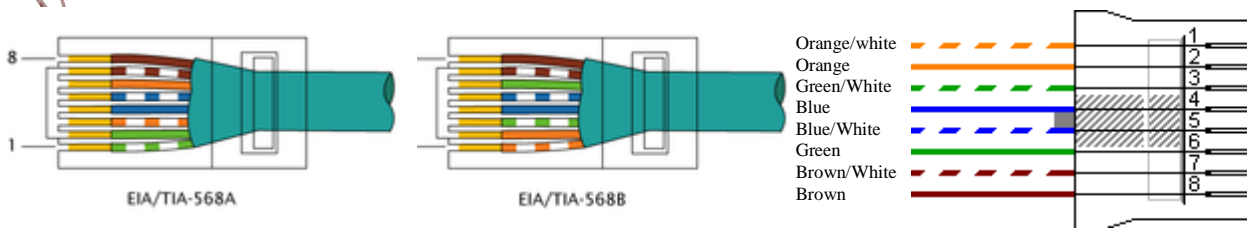



A Registered Jack socket (**RJ-11**) is used for telephone systems. The figure below shows the **RJ-11 standard phone jack diagram**. It shows the front view of the female wall jack. This color scheme is used with standard 2-pair phone cables. The slot numbers next to the Tip and Ring indicators are usually marked on the jack. Standard 2-pair wiring color codes are shown in the table below:

1st Pair	Tip (+), slot 4 Ring (-), slot 3	WHITE/BLUE (Green) BLUE/WHITE (Red)
2nd Pair	Tip (+), slot 2 Ring (-), slot 5	WHITE/(Brown) ORANGE (Black) Brown (ORANGE)/WHITE (Yellow)

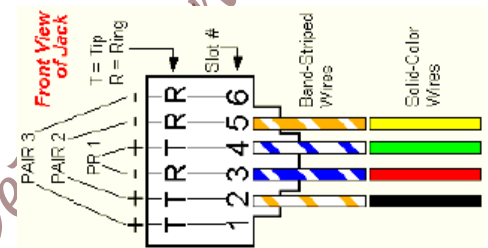

### ➤ **Procedure:**

In this part, the kWh meter, the Distribution Board (DB), main MCB and EL (RCD), and MCBs in a symbolic flat, shown in Figure 8.1, will be assembled. Also, extra low voltage components will be installed. The conduits marked with green paint are designed for lighting wiring, conduits marked with red paint are designed for power wiring, and conduits marked with blue paint are designed for Extra low voltage wiring. The overall electrical plan is shown in Figure 8.2.

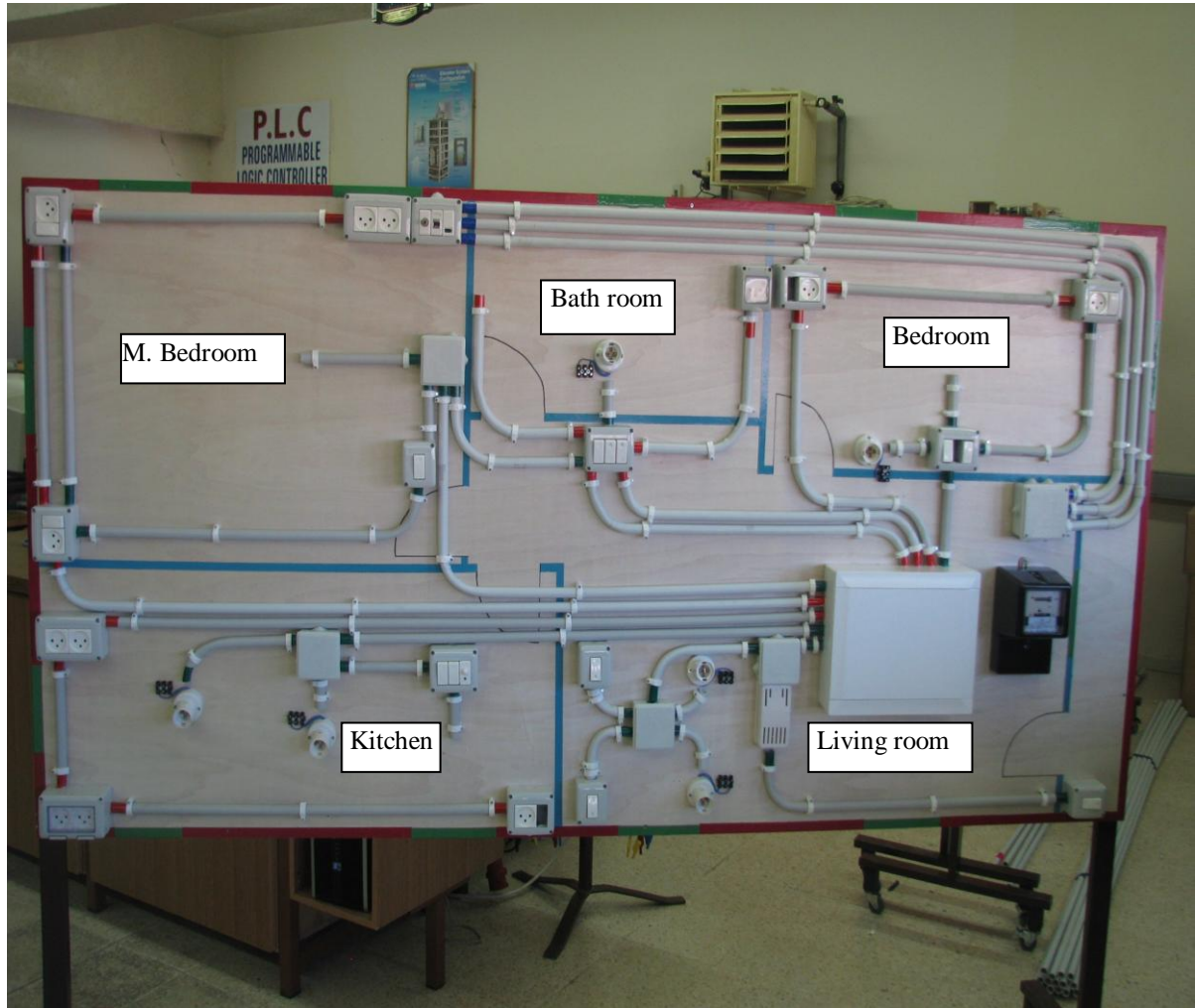
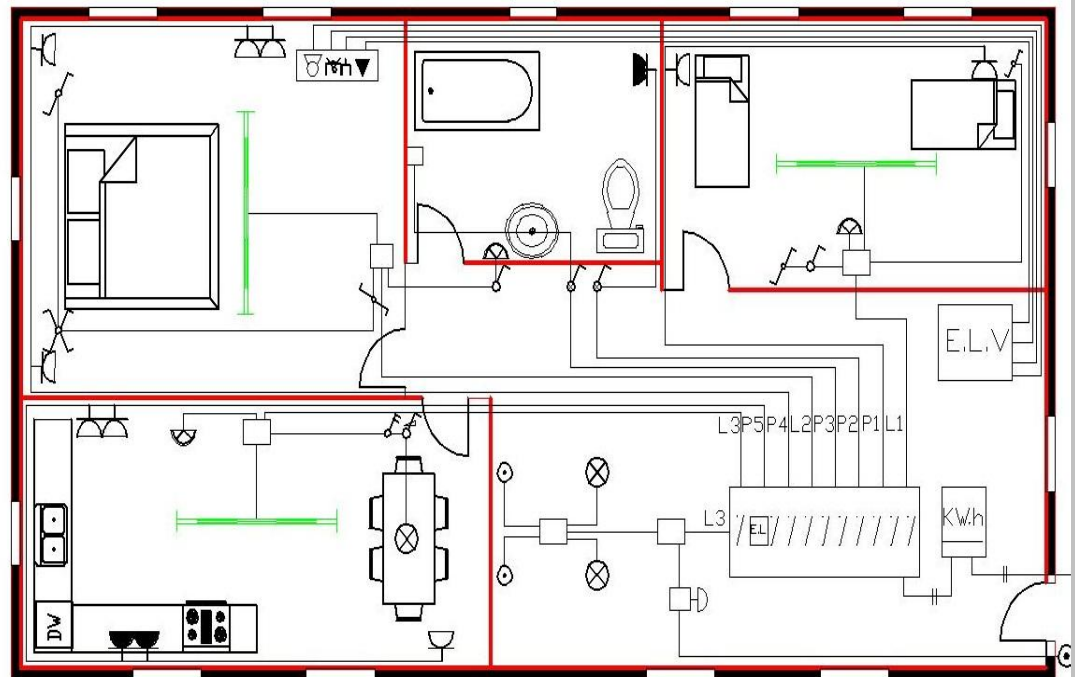

**Figure 8.1:** A photo of conduits, installations, and wiring in a symbolic flat consisting of a living room, a bedroom, a master bedroom, a bathroom and a kitchen

## General Drawing

Table of Symbols

	150WATT FLUORESCENT LIGHT
	Two Way Switch
	ON/OFF One Way Switch
	Two circuit Switch (Double Switch)
	Side Lamp
	Ceiling Lighting Point
	Cross Switch
	Push Button
	Electrical Bell
	Double Pole Switch with Indicator lamp
	Power Socket -Single Phase
	Power Socket-Water Proof
	Boiler
	Extra Low Voltage Board
	Telephone Socket
	Satellite Socket
	Television Socket
	Dimmer Switch
	Data Socket



**Figure 8.2:** The overall electrical plan of the symbolic flat

The installation procedure consists of 4 tasks specified as follows:

### a) Task # 1: Installation of kWh meter and MCBs

In this task, the main  $3 \times 6 \text{mm}^2$  cable, the kWh meter, the main MCB and EL (RCD), the Timer and the MCBs will be installed. The Distribution Board (DB) will include 3 MCBs for the lighting circuit protection and 5 MCBs for the power circuit protection. You need to implement the installation in the following steps' sequence:

1. Connect the kWh meter with the main cable; phase and neutral conductors. **Make sure that the main cable terminals are NOT connected to the supply.** The connection of the kWh meter was specified earlier in the introduction and is shown in Figure 8.3
2. Install the phase, neutral, and earth bus-bars inside the Distribution Board (DB)
3. Mount a 25A-MCB on its holder within the DB

4. Mount an Earth Leakage (EL or RCD) on its holder within the DB
5. Make sure that the Timer Selector **1** (at the right side of the timer) is set to position '3', before mounting the Timer on the holder within the DB
6. Mount three 10A-MCBs on the holder within the DB
7. Mount five 16A-MCBs on the holder within the DB
8. Connect the wires of appropriate colors, lengths and cross sectional areas, between kWh meter and MCBs, EL and phase, neutral and earth bus bars in the DB, as shown in Figure 8.3
9. Ask your lab supervisor to check connections!

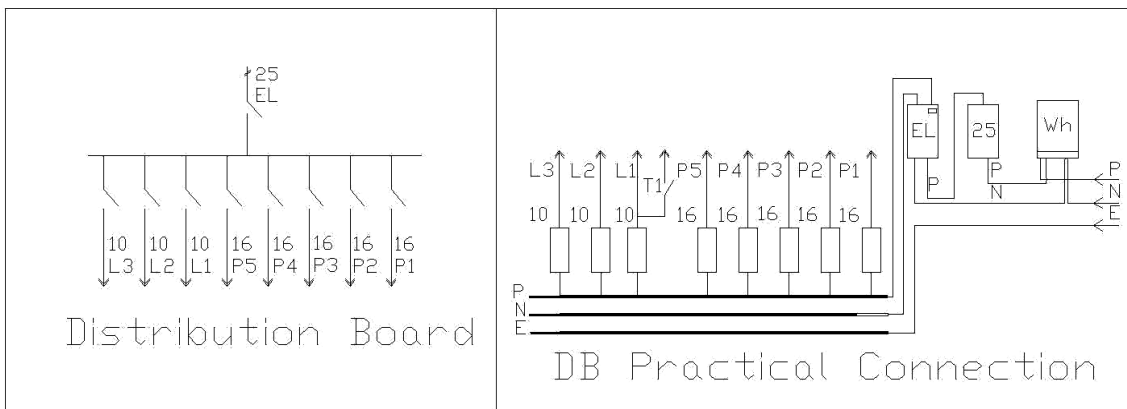
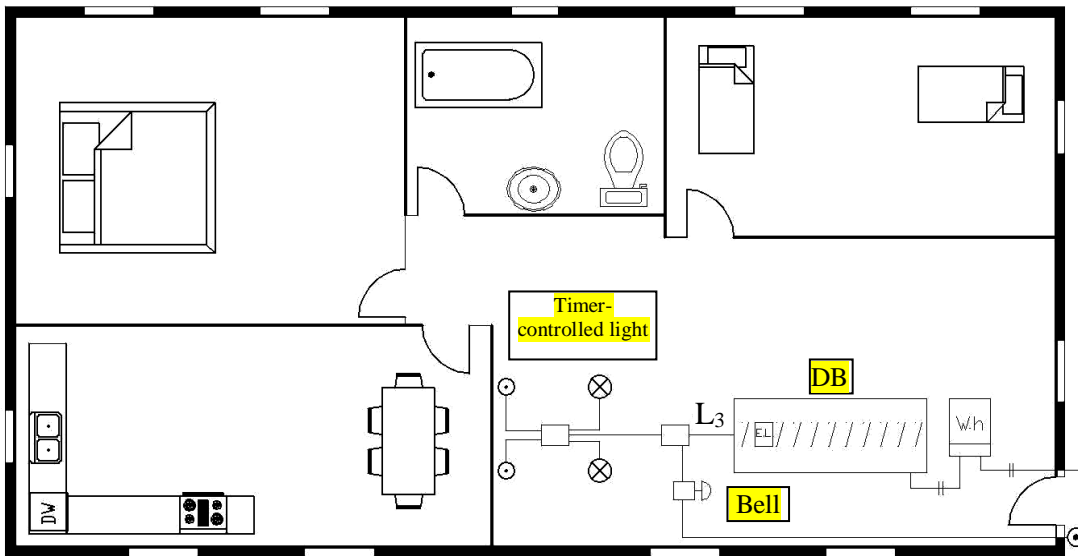
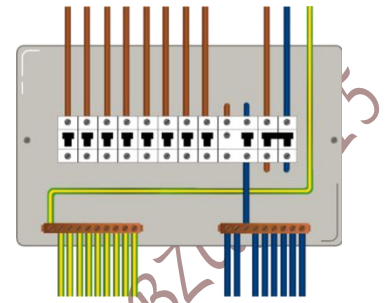
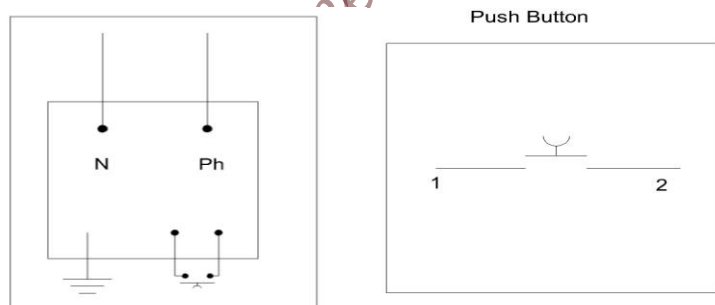

**Figure 8.3:** The Electrical plan for the Distribution Board and kWh meter, stair-case lighting and Electric bell

### b) Task # 2: Electric Bell Installation

The transformer-primary of electrical-bell will be fed from  $L_3$  – MCB via  $1.5\text{mm}^2$ . An earth conductor must be connected between the earth bus-bar in DB and the earth pin of the bell. The push button, located outside the flat, will be connected to the terminals assigned for it on the electric bell, as shown in Figures 8.3 and 8.4. To install the bell and the bush button, follow the following steps (**note that all wires in the same conduit should be run simultaneously**):

1. Run or fish 3 wires ( $1.5\text{mm}^2$ ) from the DB to the electric bell; a brown wire for the phase from  $L_3$  -MCB output to the bell P-terminal, a blue wire from the neutral bus-bar to the bell N-terminal, and a yellow with green-stripe wire between the earth bus-bar in DB to the bell ground terminal
2. Run two  $1.5\text{mm}^2$  wires (of any other two colors) between the push button point and the electric bell location
3. Assemble all wires to the bell and push button as shown in Figure 8.4
4. **Ask your lab supervisor to check connection!**



**Figure 8.4:** An electric Bell terminals' configuration and push-button terminals

### c) Task # 3: A Timer-Controlled Lighting

A relay timer will be used to control the lighting of the living room (usually the timer relay is used to control the lighting of a stair case). The lighting will be activated by two push buttons located in the living room (in practice, the push buttons are located (at accessible locations) within the stair case, and so are the timer-controlled lighting fixtures). In this task, two lamps located in the living room will be controlled by the timer, as shown in Figure 8.3. The timer terminals configuration is shown in Figure 8.5. To implement the timer controlled lighting,

follow the following steps (**note that all wires in the same conduit should be run simultaneously**):

1. **Ensure that selector ① (at the right side of the timer) is set to position '3'**, as shown in Figure 8.5
2. Connect a brown 1.5mm<sup>2</sup> jumper between L<sub>3</sub> - MCB and the timer L-terminal

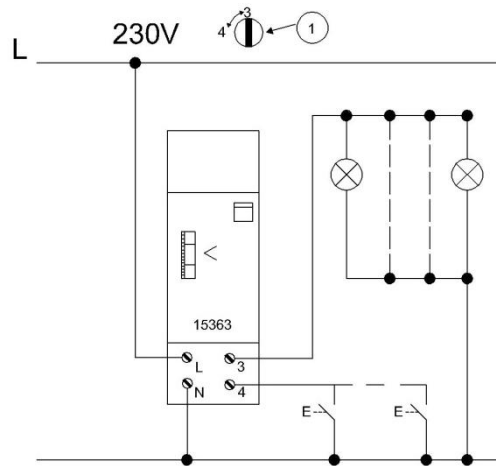

**Figure 8.5:** Schneider timer terminals' configuration and setting

3. Connect a blue 1.5mm<sup>2</sup> wire between DB neutral bus-bar and the timer N-terminal
4. Run a blue 1.5mm<sup>2</sup> wire from the DB neutral bus-bar to the connection box
5. Run a blue 1.5mm<sup>2</sup> wire from each lamp and push button to the connection box, then join all together using terminal blocks (shown in the next figure)
6. Run violet 1.5mm<sup>2</sup> wires between terminal 4 of the timer (in DB) and each push button
7. Run 1.5mm<sup>2</sup> wires of brown with black stripes color between each lamp and terminal 3 of the timer
8. Connect all wires to the terminals of the timer, lamps and push buttons
9. **Ask your lab supervisor to check connections!**



#### d) Task # 4: Extra Low Voltage (ELV) Installations

In this task, a wiring of Telephone, Television and Internet systems will be conducted and implemented in the symbolic flat. A socket for each system will be installed in the master bedroom. The wiring between the ELV box and sockets will be exercised. Figure 8.6 shows the ELV plan of the symbolic flat.

To implement the ELV installations, follow the following steps:

1. Run or fish a coaxial cable between the TV socket in the master bedroom and the ELV box in the living room.
2. Connect the coaxial cable to the TV socket
3. Run or fish a telephone cable (2 pairs) between the telephone socket (**RJ-11**) in the master bedroom and the ELV box in the living room

Table of Symbols

EL.V	Extra Low Voltage Board
▼	Telephone Socket
□	Satelite Socket
Ⓜ	Television Socket
Ⓜ	Data Socket

Low Voltage Diagram

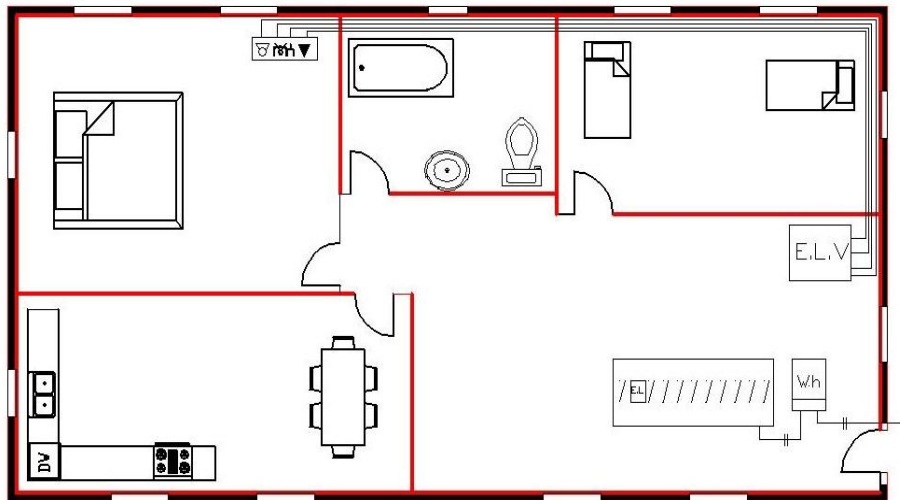

Figure 8.6: The Extra Low Voltage plan of the symbolic flat



4. Connect the telephone cable to the **RJ-11** socket, as shown in the figure below

1st Pair	Tip (+), slot 4 Ring (-), slot 3	WHITE/BLUE BLUE
2nd Pair	Tip (+), slot 2 Ring (-), slot 5	WHITE/Brown Brown

5. Run or fish an Ethernet cable (4 twisted pairs) between the internet socket (**RJ-45**) in the master bedroom and the ELV box in the living room

6. -Connect the Ethernet cable to the socket implementing **color convention - EIA/TIA 568B** as shown in the figure below

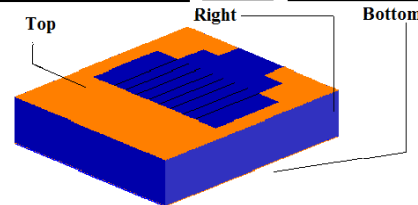
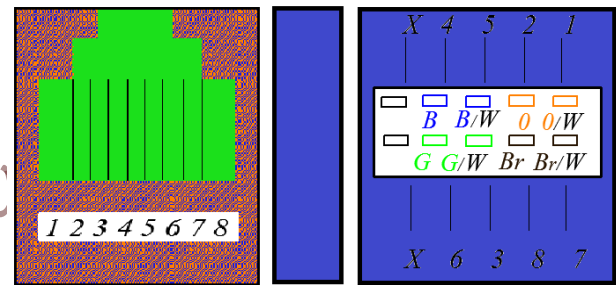
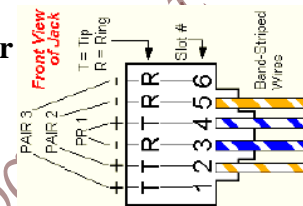
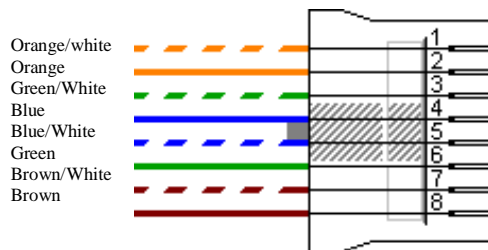

7. Ask your lab supervisor to check connections!



## Experiment # 9 Implementation of Lighting Installations

### ➤ Objectives:

The experiment covers principles of Domestic Lighting, the following major topics are included:

1. Types of switches and controls used in Domestic Lighting
2. Basics of switch wiring
3. Basics of lighting fixture and luminaries
4. Installation of lighting circuits for a flat

### ➤ Introduction:

Note:

- The cross sectional area of wires for lighting circuits is  $1.5 \text{ mm}^2$
- The conduits designed for lighting circuits are marked with green paint.
- All wires in the same conduit should be run at once.

### A) Installation of switches:

Switch wiring can be divided into three parts according to the type of connection used for the switch:

1. Single-pole switch is used to control a luminary or other equipment from one location.
2. Two-way switch is used to control a luminary or other equipment from two locations.
3. Intermediate switch is used with 2 two-way switches to control a luminary or other equipment from three or more locations.

#### I) Single-pole switch:

A single-pole switch has two terminals and is marked with on and off positions. It is used to control a luminary from one location. For a lamp, one Live phase and one neutral are necessary.

To control the supply to the lamp, a switch is introduced in the Live wire and the neutral is directly connected to the lamp. When the switch is ON, a full voltage gets applied to the lamp and it glows. When the switch is turned off, the circuit gets opened and the lamp gets switched off. The wiring circuit for a lamp controlled by one switch is shown in Figure 9.1. The switch is always connected in the phase wire so as to ensure the safety of the personal doing the maintenance at the lamp holder.

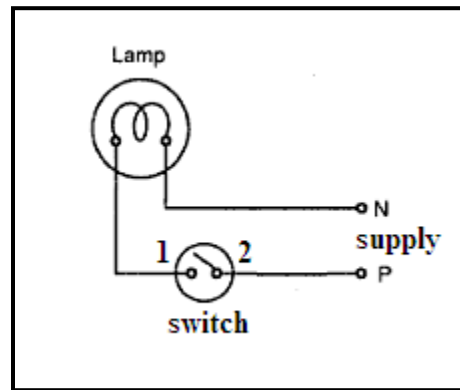

Figure 9.1: Single-pole switch wiring circuit

(II) Two-way switch:



A two-way switch is used to control a lamp from two locations.

It is called two-way switch because it has three wiring terminals that can be connected in two different positions, as shown in Figure 9.2. One terminal is called the common terminal (pin 2)

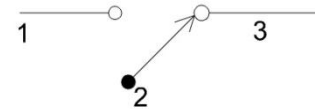

and is connected to the live conductor or a lamp. The other two terminals are called traveler terminals. Two conductors, called travelers or strappers, run from these terminals to the traveler terminals of a second two-way switch.

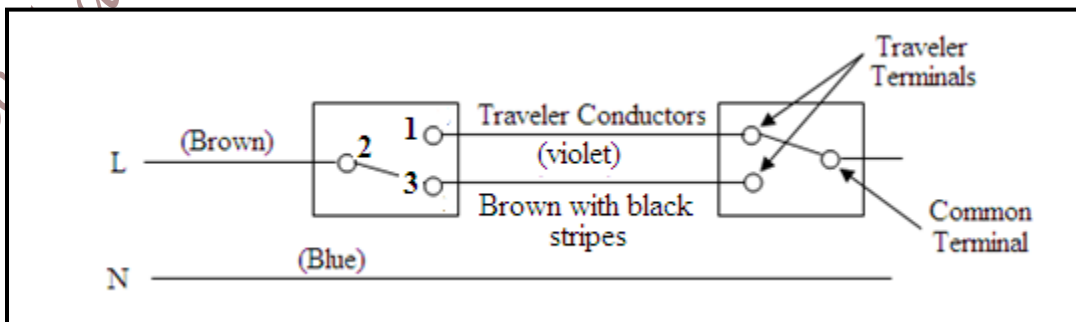

Figure 9.2: Connection of 2 two-way switches

(III) Intermediate switch: (Cross Switch)



One or more intermediate (cross) switches can be used with a pair of two-way switches to control a lamp from three or more locations. The cross switch has four terminals that can be connected in two different positions as shown in Figure 9.3. The two sets of traveler conductors run between two-way and cross switches.

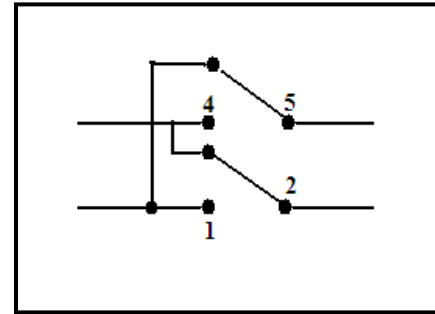

Figure 9.3: Intermediate switch (cross switch)

**B) Switch wiring:**

A couple of general considerations apply to all switch wiring. First, switching always takes place in the live conductor. Neutral conductors are usually not permitted to be switched. According to the color coding, conductors with brown (or red) insulation are used as a part of switch loop. The neutral wire is blue (or black), the earth wire is yellow with green stripes, whilst the traveler is violet, brown with black stripes, green, or any different color.

**I) Single pole switches:**

The source of supply for single-pole switches should be coming from the Distribution Board (DB). In this case, the branch circuit runs first to the switch (connection) box and then up to the lighting, as shown in Figure 9.4.

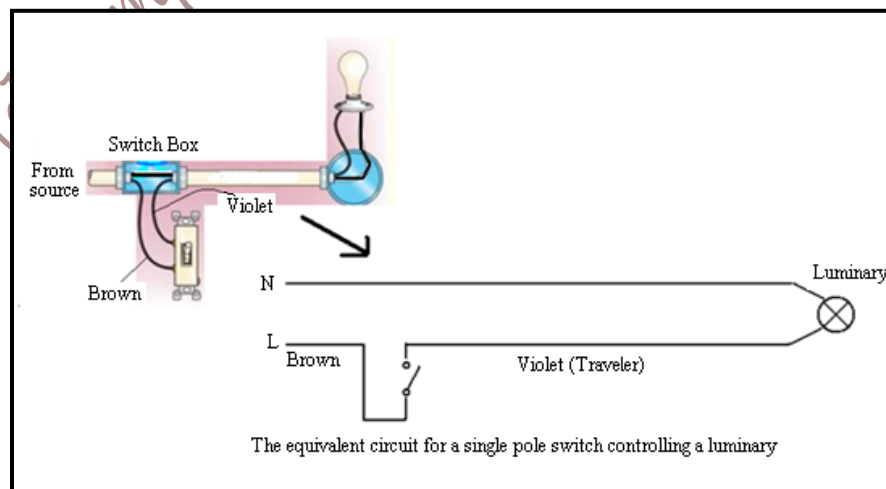

Figure 9.4: Wiring for a single pole switch controlling a luminary

## II) Two-way switches:

2 two-way switches are used to control a luminary from two different locations. Figure 9.5 shows the wiring of the two switches. The neutral (blue) conductor is connected directly to the luminary, also, is the earth (yellow with green stripes) conductor if the luminary has a metallic frame. The phase conductor (brown) is connected to one port of the first two-way switch (pin3) which is closest to the main distribution board (source). Two traveler conductors (violet and brown with black (or orange) stripes) run between the two switches. The luminary is connected to the third port of the second switch (pin 3') via a conductor of different color.

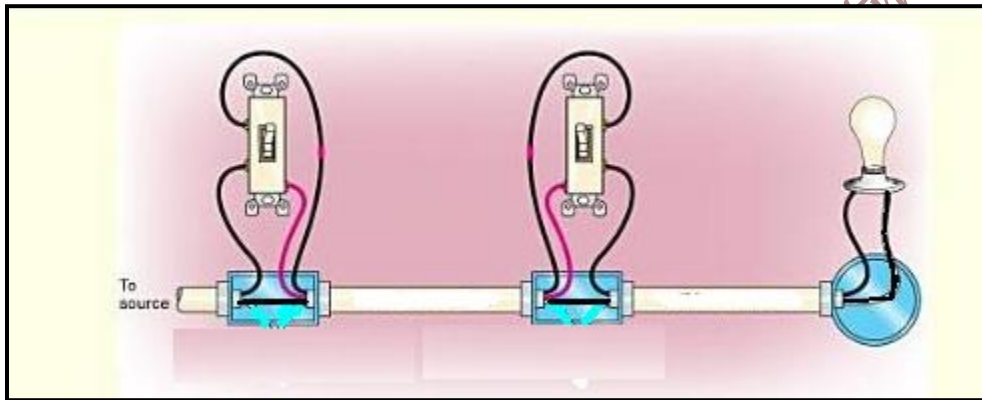

Figure 9.5: A type of a luminary controlled by 2 two-way switches

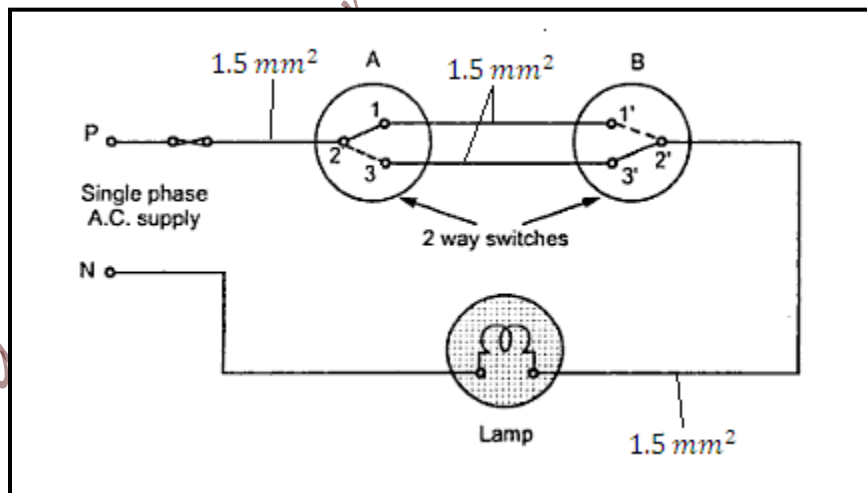

Figure 9.6: The wiring diagram for controlling a lamp from two different locations

In Figure 9.6, the phase wire is connected to terminal 2 of the first two way switch “A”. The movement of a switch makes connection from terminal 2 to either of the terminals 1 or 3. A similar two way switch is installed at another location. With positions of switches shown in Figure 9.6, the lamp is OFF. The table 9.1 shows the positions of switches and condition of the lamp.

Table 9.1: Switch position and lamp status

Switch A	Switch B	Lamp
1	1'	ON
1	3'	OFF
3	1'	OFF
3	3'	ON

The equivalent circuit diagram of the two-way switch as controlling a luminary is as shown in Figure 9.7.

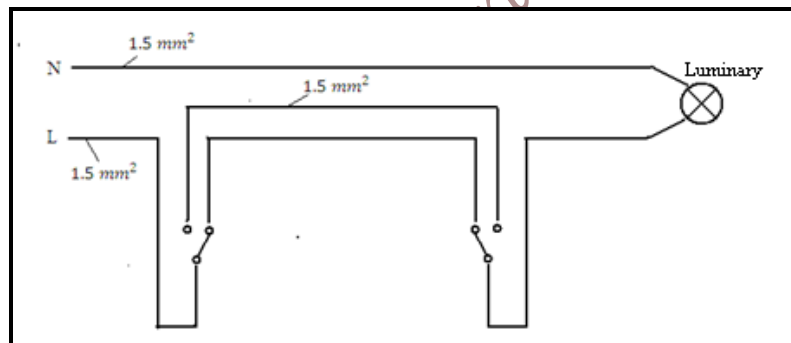

Figure 9.7: The equivalent circuit diagram for 2 two-way switches controlling a lamp

### III) Intermediate or Cross Switch:

Intermediate switching is essentially the same as two-way except that the two traveler wires between the two-way switches are also connected to the cross switches. Figure 9.8 next shows the connection of intermediate (cross) switch to control a luminary from three locations.

This type of wiring consists of 2 two-way switches (A and B) and one intermediate (cross) switch C. The circuit used to control the lamp from three locations is shown in Figure 9.8. The intermediate switch can have positions to connect points: 1 – 5, 2 – 4 as shown, or 1 – 2, 4 – 5 shown dotted. In the position shown in Figure 9.8, the lamp is ON.

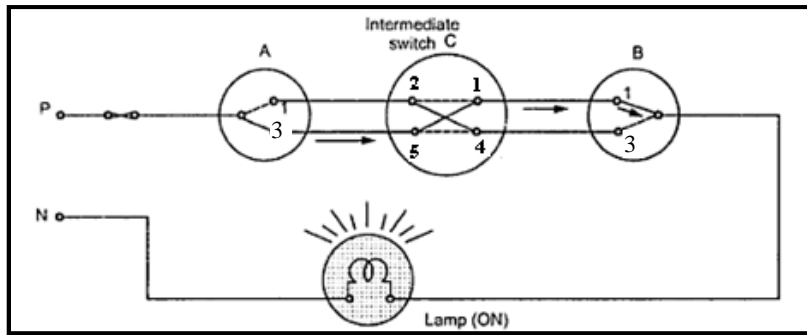

Figure 9.8: The wiring diagram for controlling a lamp from three different locations

### C) Fluorescent Lamp or Tube Light

Figure 9.9 shows the constructional details of fluorescent lamp. It consists of a long glass tube which is internally coated with a suitable amount of fluorescent powder. A small amount of mercury along with a little quantity of argon gas is also filled in the tube.

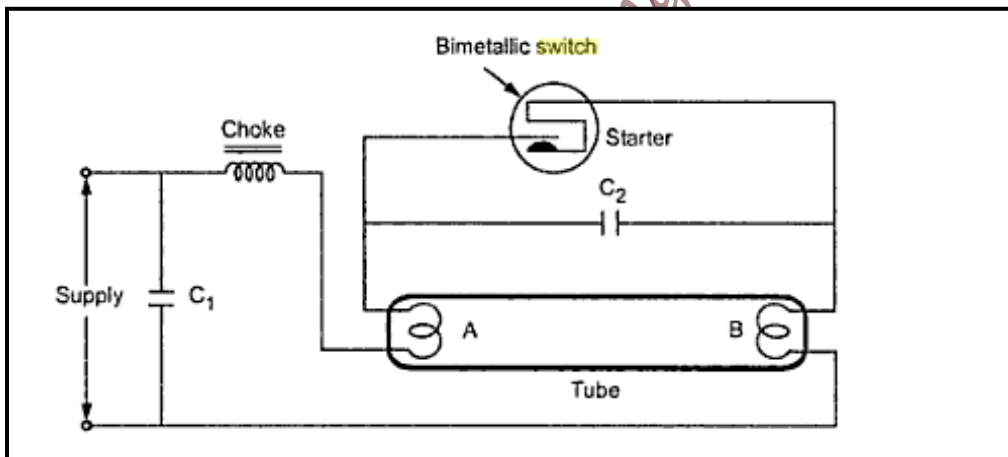

Figure 9.9: The construction of fluorescent lamp

There are two electrodes A and B made up of coiled tungsten filament coated with an electron emitting material. The control circuit of the tube contains a starter (bimetallic), a choke L and two capacitors  $C_1$  and  $C_2$ .

Another type of starter is the glow type starter, which is shown in Figure 9.10, and is commonly used.

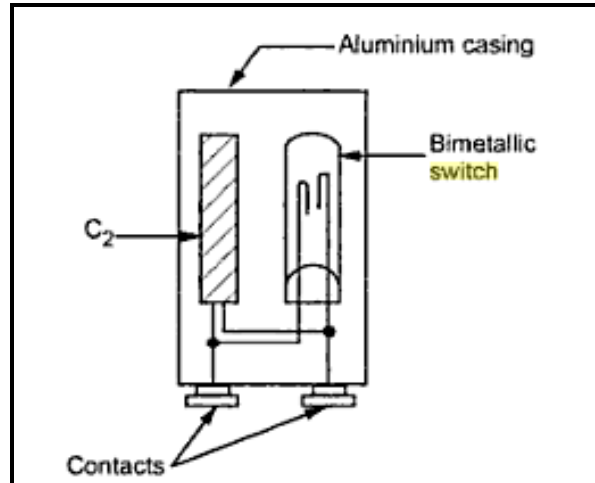

Figure 9.10: The glow type starter

i. Operation of Starter:

The bimetallic starter has its contacts closed when it is cold and they separate as a current flows in it. On the other hand, the glow starter has an electric arc established between the electrodes of the starter when the supply is switched ON. Due to this arc, heat is produced which is sufficient to bend the bimetallic stripe which makes contact with fixed electrode. This closes the circuit, and therefore the chock carries a large current. Once the electrodes close, arc vanishes and bimetallic stripe cools down again and separates.

ii. Operation of Fluorescent Lamp:

When the switch is closed, a current passes through the starter to the electrodes. Now the electrodes A and B become hot, and as a result of opening the starter terminals, the current through the chock coil is suddenly reduced to a small value. This change in current induces an emf which is very high (up to 500V) in the chock coil. This emf induced is sufficient for ionizing the gas molecules between electrodes A and B which establishes the discharge between the electrodes A and B through the gas.

The potential difference across the tube falls to about 220 V, which is sufficient to maintain the discharge but not sufficient to restart the glow in the circuit. So even if the starter is removed from the circuit, discharge continues as the current flows from electrode A and B due to ionization of gas.

As the chock lowers the power factor to be around 0.55 (or even less) lagging, the capacitor  $C_1$  used in the circuit improves the power factor. For a single tube (36W – 40W) a capacitor  $C_1$  of  $4\mu\text{F}$  is used (exact calculations may be done).

The capacitor  $C_2$  suppresses the radio interference developed due to arcing. The function of the inductive chock is to supply a large voltage surge for establishing the discharge between the electrodes A and B.

Note that the efficiency of Fluorescent Lamp is more than three times the efficiency of Standard Incandescent Lamp of a similar power rating.

### ➤ **Procedure:**

Figure 9.13 shows a photo of conduits, installations, and wiring in a symbolic flat consisting of a living room, a bedroom, a master bedroom, a bathroom and a kitchen. Note that the conduits marked with green paint are designed for lighting wiring, conduits marked with red paint are designed for power wiring, and conduits marked with blue paint are designed for Extra low voltage wiring. **Also, note that all the conductors in a conduit should be run altogether simultaneously.** In this experiment, the lighting installations for the given flat will be implemented. Figure 9.11 shows the overall wiring of the flat. However, the diagram of lighting installations is shown in Figure 9.12. The implementation will be divided into 4 tasks specified as follows, noting that the living room wiring was conducted in the previous experiment:

#### **Task # 1: Bedroom Lighting Installations**

The lighting of the bedroom will be activated by 2 two-way switches and a one way switch located in the bedroom. In this task, the fluorescent lamp and side lamp will be installed in the bedroom, as shown in Figure 9.13. To implement the wiring diagram and installation of luminaries and switches (Figure 9.12), follow the following steps (**note that all wires in the same conduit should be run simultaneously**):

1. Assemble the fluorescent and the side lamps in the room
2. Run a blue  $1.5\text{mm}^2$  wire from the DB neutral bus-bar to the switches and lamps



3. Repeat step 2 for a yellow with green stripes for the earth conductor
4. Run a brown wire for the phase from  $L_1$  – MCB output to the one way switch and the closest two way switch; all the 3 wires should be run together.
5. Run two  $1.5\text{mm}^2$  wires (a violet and a brown with black (or orange) stripes) between the first two-way switch and the second two-way switch.
6. Run another wire from the second two-way switch, all the way back to the fluorescent lamp via the first two-way switch box.
7. Assemble all the wires to the lamps, switches and MCB. **Note that all the three wires between the 2 two-way switches should be run all together.**
8. Run a violet wire between the single (one-way) switch and the side lamp
9. **Ask your lab supervisor to check connections!**

2015

Table of Symbols

—	1000 VATT FLUORESCENT LIGHT
⌋	The Key switch
⌋	ON/OFF One Key switch
⌋	The circuit switch (Double switch)
⊗	Side Lamp
⊗	Ceiling Lighting Point
⊗	Down switch
⊙	Push Button
⊙	Bi-directional Bell
⌋	Double Pole Switch with Indicator Lamp
⌋	Power Socket -Single Phase
⌋	Power Socket-Three Phase
⌋	Socket
□	ELV
□	Extra Low Voltage Board
▼	Telephone Receiver
⌋	Shielded Receiver
⌋	Telephone Socket
⌋	Dimmer Switch
⌋	Data socket

General Drawing

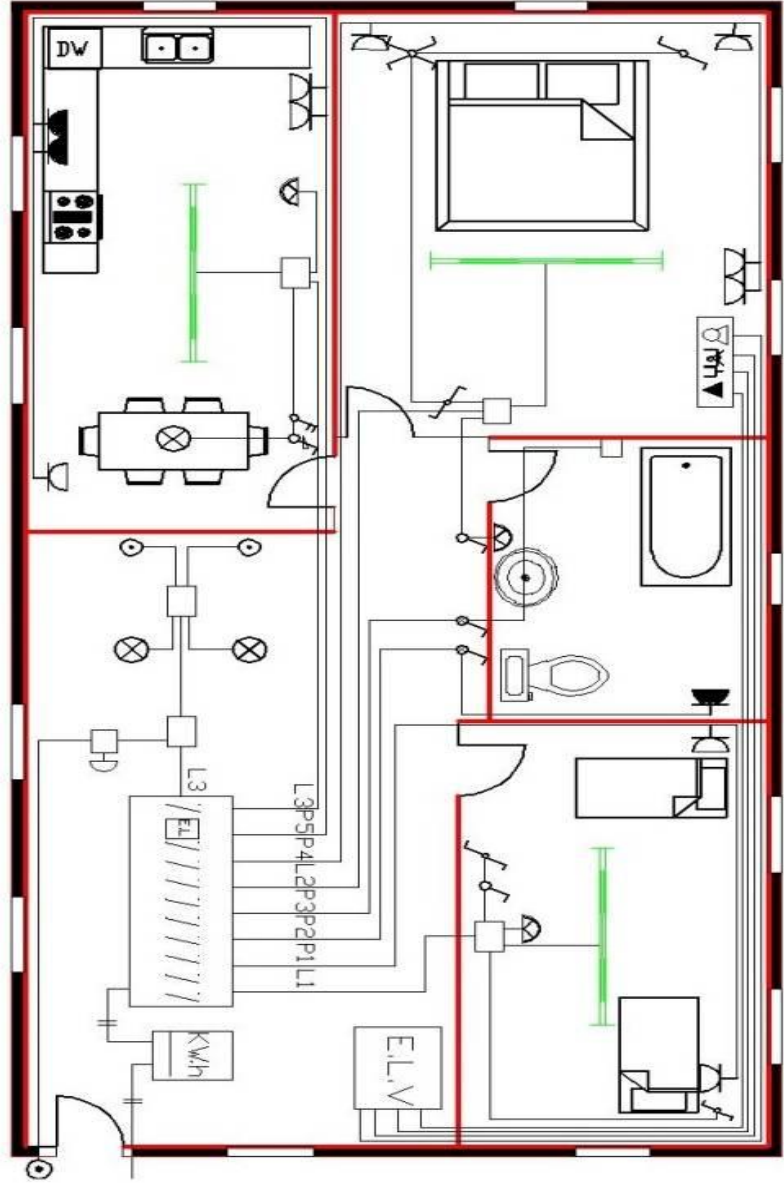

Figure 9.11: The overall wiring diagram for the flat

Electrical

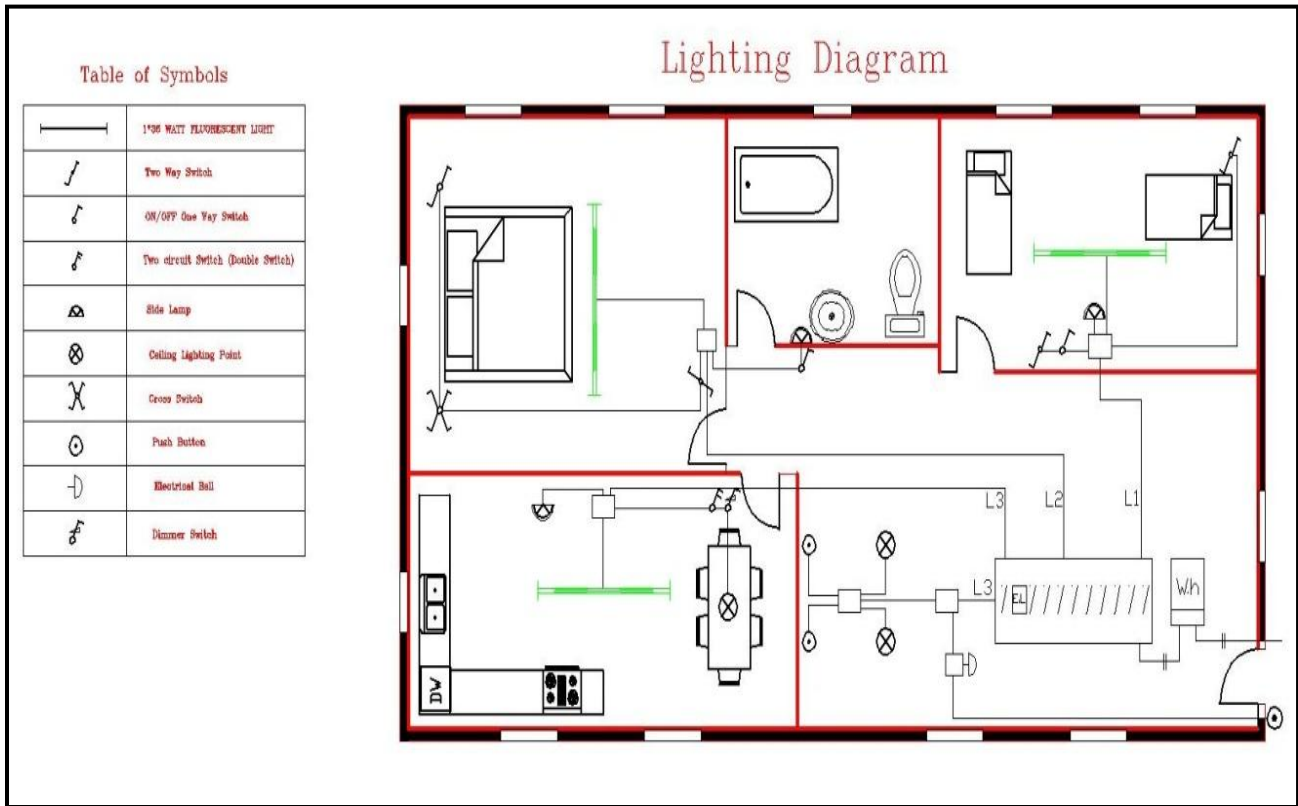

Figure 9.12: Wiring diagram for lighting

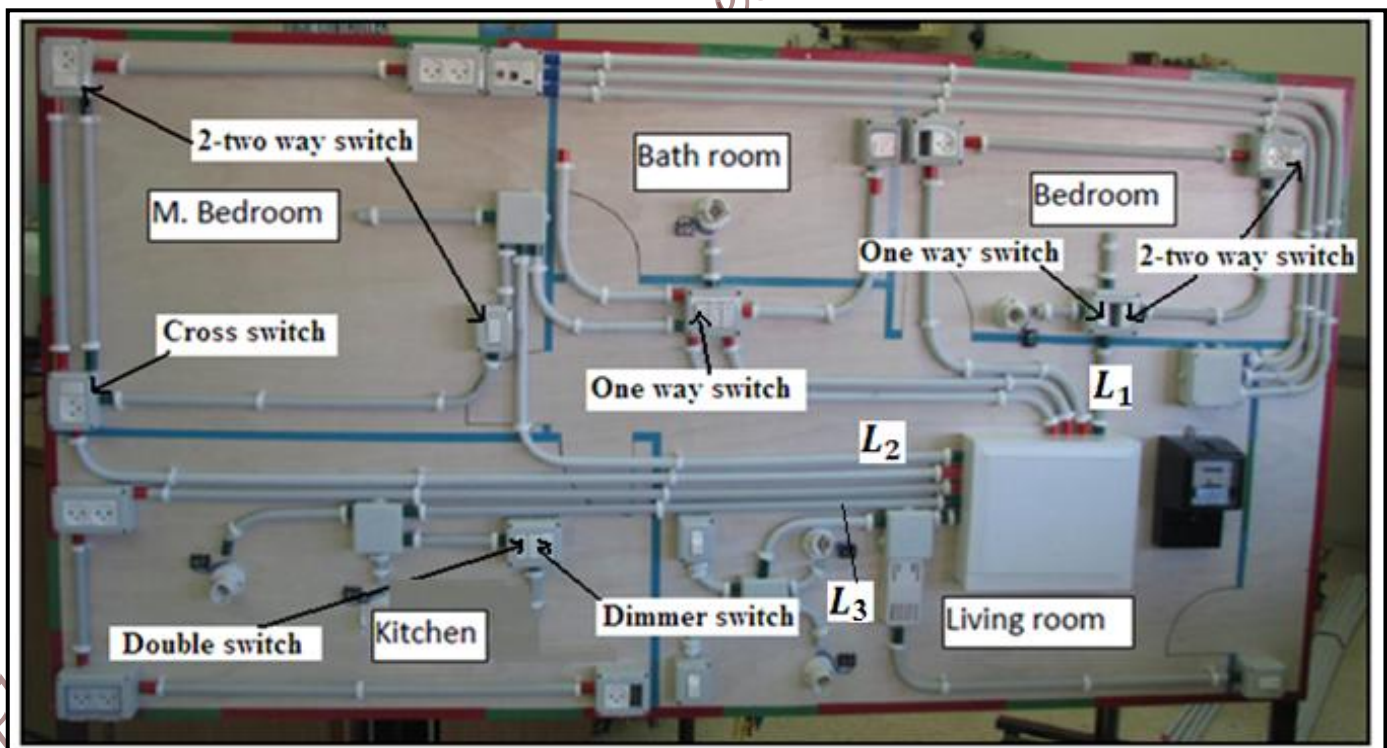

Figure 9.13: A photo of conduits, installations, and wiring in a symbolic flat consisting of a living room, a bedroom, a master bedroom, a bathroom and a kitchen

### **Task # 2: Master Bedroom Lighting Installations**

The lighting of master bedroom will be activated by 2 two-way switches and a cross switch located in the master bedroom. In this task, the fluorescent lamp will be installed in the room, as shown in Figure 9.13. To implement the wiring diagram and installation of luminary and switches, follow the following steps (**note that all wires in the same conduit should be run simultaneously**):

1. Assemble the fluorescent lamp in the room
2. Run a blue 1.5mm<sup>2</sup> wire from the DB neutral bus-bar to the connection box
3. Run a blue 1.5mm<sup>2</sup> wire between the fluorescent lamp and the connection box, then join all together using terminal blocks
4. Repeat step 2 and 3 for a yellow with green stripes for the earth conductor
5. Run a brown wire for the phase from L<sub>2</sub> – MCB output to the connection box
6. Run a brown wire from the connection box to the first two-way switch next to door
7. Run two 1.5mm<sup>2</sup> wires (a violet and brown with black (or orange) stripes) between the two-way switch and the cross switch
8. Repeat step 7 for the connection between the cross switch and the second two-way switch (opposite corner) by using 1.5mm<sup>2</sup> wire of a different color
9. Run another wire from the second 2 two-way switches all the way back to the Fluorescent lamp via the connection box
10. Assemble all the wires to the lamp, switches and MCB
11. **Ask your lab supervisor to check connections!**

### **Task # 3: Bathroom Lighting Installations**

The lighting of the bathroom will be activated by an ON/OFF one way switch located in the master bathroom. In this task, a lamp will be installed in the bathroom as shown in Figure 9.13 (in practice water proof lamps must be used). To implement the wiring diagram and installation of the lamp and switch, follow the following steps (**note that all wires in the same conduit should be run simultaneously**):

1. Install the lamp in the bathroom

2. Run a blue (neutral)  $1.5\text{mm}^2$  wire from the lamp to the connection box in the master bedroom, then join it to a blue  $1.5\text{mm}^2$  wire that was run in the previous task from the DB neutral bus-bar to the connection box.
3. Repeat step 2 for a yellow with green stripes wire for the earth conductor
4. Run a brown wire from the connection box to the switch
5. Run a violet  $1.5\text{mm}^2$  wire from the one way switch to the lamp
6. Assemble all components together.
7. **Ask your lab supervisor to check connections!**

#### **Task # 4: Kitchen Lighting Installations**

The lighting of the kitchen will be activated by a double switch and a dimmer switch located in the kitchen. In this task, the fluorescent lamp and other two side lamps should be assembled in the kitchen, as shown in Figure 9.13. To implement the wiring diagram and installation of luminaries and switches, follow the following steps, (**note that all wires in the same conduit should be run simultaneously**):

1. Install all the lamps in the Kitchen.
2. Run a blue  $1.5\text{mm}^2$  wire from the DB neutral bus-bar to the connection box
3. Run a blue  $1.5\text{mm}^2$  wire from each lamp to the connection box, then join all together using terminal blocks
4. Repeat step 2 and 3 for a yellow with green stripes wire for earth conductor
5. Run a brown wire for the phase from  $L_3$  – MCB output to the connection box
6. Run a brown wire from the connection box to each of the double switch and the dimmer switch
7. Run two  $1.5\text{mm}^2$  wires (a violet and brown with black (or orange) stripes) between the double (gang) switch and the far lamp and Fluorescent lamp
8. Run another wire from the dimmer switch directly to the lamp next to it
9. Assemble all the wires to the lamps, switches and MCB via terminal blocks.
10. **Ask your lab supervisor to check connections!**

*Electrical and Computer Engineering Department-BZU, 2015*

## Experiment # 10 Implementation of Power Installations

### ➤ **Objectives:**

The experiment covers principles of Domestic AC power plugs and sockets. The following major topics are included:

1. Types of outlets used in power installations
2. Installation of power circuits for a symbolic flat

### ➤ **Introduction:**

Note:

- The cross sectional area of wires for power circuits is  $2.5 \text{ mm}^2$
- The MCB rating for a power circuit is 16 A
- The conduits designed for power circuits are marked with red paint.
- All wires in the same conduit should be run simultaneously.

#### **A) What are the plugs and sockets (Outlets)?**

AC power plugs and sockets are devices for connecting electrically operated devices to the primary power supply in homes and buildings. Electrical plugs and sockets differ by country in voltage and current rating, shape, size and type of connectors. The types used in each country are set by national standards.

Generally the plug is the movable connector attached to an electrically operated device's power cord as shown in Figure 10.1, and the socket is a fixture on equipment or a home structure as shown in Figure 10.2. Plugs have male circuit contacts, while sockets have female contacts. The plug has protruding prongs, blades, or pins that fit into matching slots or holes in the socket. A wall-mounted socket is also called a receptacle, outlet, or power point. It is enclosed by a cover variously called a wall plate, face plate, outlet cover, socket cover, or wall cover.





Figure 10.1: A Plug



Figure 10.2: A Socket Outlet

To reduce the risk of electric shock, plug and socket systems can incorporate a variety of safety features. For example, sockets can be designed to accept only compatible plugs and reject all others. There are many systems which block the socket holes with insulators when a plug is not inserted, and some systems are designed such that a dangerous voltage is never present on an exposed contact. Exposed contacts are present in some sockets, but are used exclusively for grounding (earthing).

### **B) Types of Wall Socket Outlets:**

Many wall socket outlets are polarized to make it impossible for users to plug objects in to the wall incorrectly. Polarized outlets are configured to only accept a plug in such a position that the grounding and live wires within the wall correspond to the same wires within the plug. In a simple two-pronged outlet for example, one of the prongs is designed to be wider than the other so that the plug will only fit when inserted correctly. Non-polarized wall sockets accept plugs of any configuration, and pose added risk to users.

Different types of wall sockets can be found within homes and other buildings. Figure 10.3 shows a single wall socket, it accepts only a single power cord, and is typically used for large appliances like refrigerators or washing machines. Figure 10.4 shows double-socket outlets, it consists of a pair of holes that are designed to accept up to two power cords. Four-way wall sockets can accept as many as four cords. Some modern wall sockets may also include openings for USB ports to allow users to charge phones and other electronics. Moreover, Figure 10.5 shows a water proof single wall socket, which is usually used in a bathroom and/ or in kitchen.





Figure 10.3: Single wall socket outlet



Figure 10.4: Double-socket outlets



Figure 10.5: A water proof single wall socket

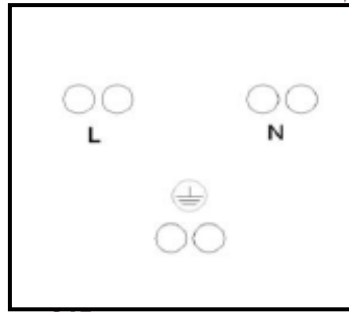

Figure 10.6: A rear view of the socket

The power socket outlet has 3 PINs. The rear view of the socket outlet is shown in the Figure 10.6. It is clear that line or phase is connected to the left PIN, the neutral is connected to the right PIN, and the earth is connected to the middle-lower PIN.

Each wall socket consists of a metal or plastic frame that fits within the surrounding drywall. This frame, or box, serves as a vessel for electrical wiring and helps to reduce the risk of electrical fires. A receptacle is connected to the wires and held within the box with screws, then a plastic or metal cover plate is fastened over top to complete the wall socket.

Many building codes have very specific requirements related to how wall sockets must be placed within a building to maximize safety. Most specify a minimum height at which these sockets must be mounted above the floor (60 – 80 cm). Others require outlets to be placed at specific intervals around the room to ensure a safe and adequate power supply for the building's occupants. The location of the sockets depends on the furniture and decoration. At least two sockets are installed in any room (three are very common).

➤ **Procedure:**

Figure 10.9 shows a photo of conduits, installations, and wiring in a symbolic flat consisting of a living room, a bedroom, a master bedroom, a bathroom and a kitchen. Note that the conduits marked with green paint are designed for lighting wiring, conduits marked with red paint are designed for power wiring, and conduits marked with blue paint are designed for Extra low voltage wiring. **Also, note that all the conductors in a conduit should be run all together simultaneously.** In this experiment, the power installations for the given flat will be implemented. Figure 10.7 shows the overall wiring of the flat. However, the diagram of power installations is shown in Figure 10.8. The implementation will be divided into 4 tasks specified as follows:

**Task # 1: Bedroom Power Installations**

The power installations in the bedroom will be represented by two single socket outlets located in the bedroom. In this task, all the socket outlets were already installed in the bedroom, as shown in Figure 10.9. To implement the power wiring diagram of socket outlets (Figure 10.8), follow the following steps (**note that all wires in the same conduit should be run simultaneously**):

1. Disassemble all socket outlets in the room
2. Run a blue 2.5mm<sup>2</sup> wire from the DB neutral bus-bar to the first single socket outlet
3. Repeat step 2 for a yellow with green stripes for the earth conductor
4. Run a brown wire for the phase from P<sub>1</sub> – MCB output to the first single socket outlet; all the 3 wires should be run together.
5. Run a blue 2.5mm<sup>2</sup> wire from the first single socket outlet to the second single socket
6. Repeat step 5 for a yellow with green stripes conductor for the earth
7. Run a brown wire from the first single socket outlet to the second single socket outlet; **all the 3 wires should be run together.**
8. Connect the wires to socket PINs, **note that all sockets are connected in parallel.**
9. **Ask your lab supervisor to check connections!**
10. After finishing the power installations, assemble all the socket outlets again

Table of Symbols

—	100 WATT FLUORESCENT LAMP
/	Two Way Switch
⌋	ON/OFF One way switch
⌋	Two circuit switch (Double Switch)
⊗	Side Lamp
⊗	Ceiling Lighting Point
X	Cross Switch
⊙	Push Button
⊙	Electrical Bell
⌋	Double Pole Switch with indicator lamp
⌋	Power Socket - Single Phase
⌋	Power Socket -Water Proof
□	Boiler
ELV	Extra Low Voltage Board
▼	Telephone Socket
h	Shuffle Socket
h	Television Socket
⌋	Dimmer Switch
⌋	Data Socket

General Drawing

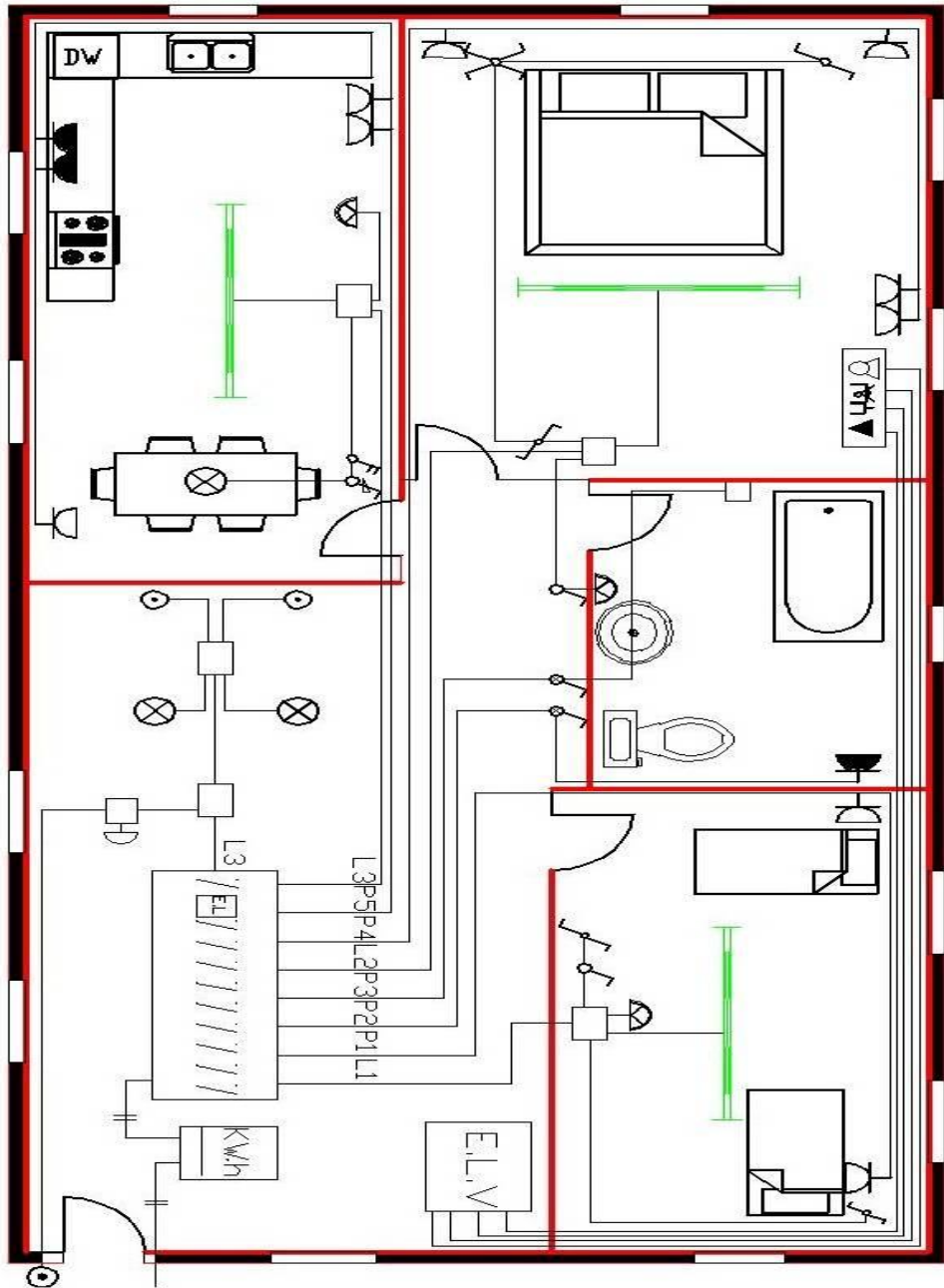





Figure 10.7: The overall wiring diagram for the flat

Ele

# Power Diagram

Table of Symbols

	Double Pole Switch with indicator lamp
	Power Socket -Single Phase
	Power Socket-Water Proof
	Boiler

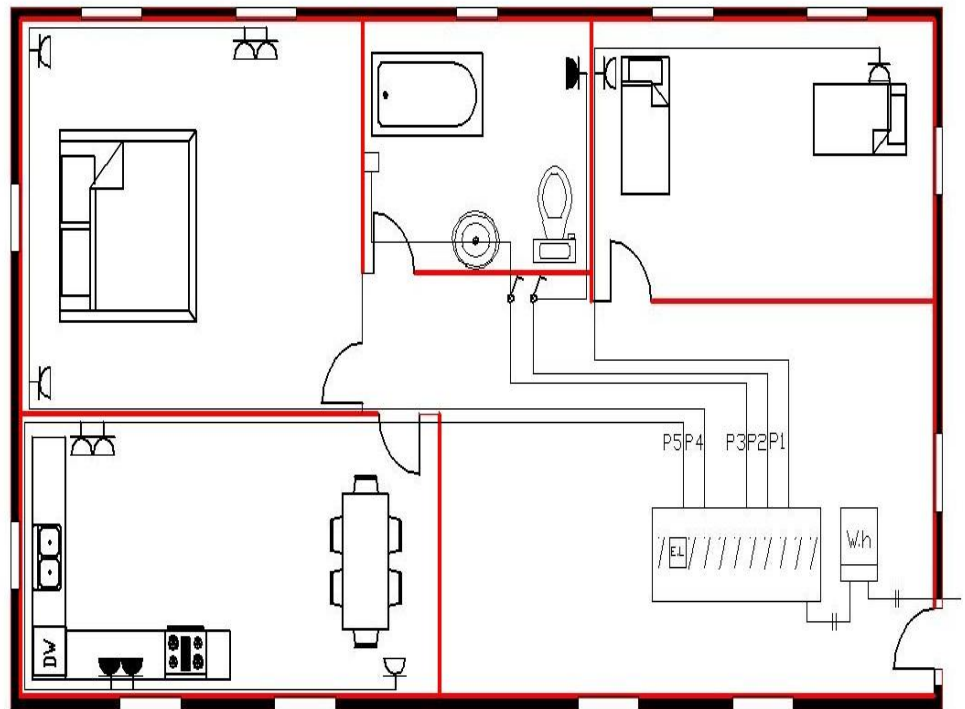

Figure 10.8: Wiring diagram for power installations

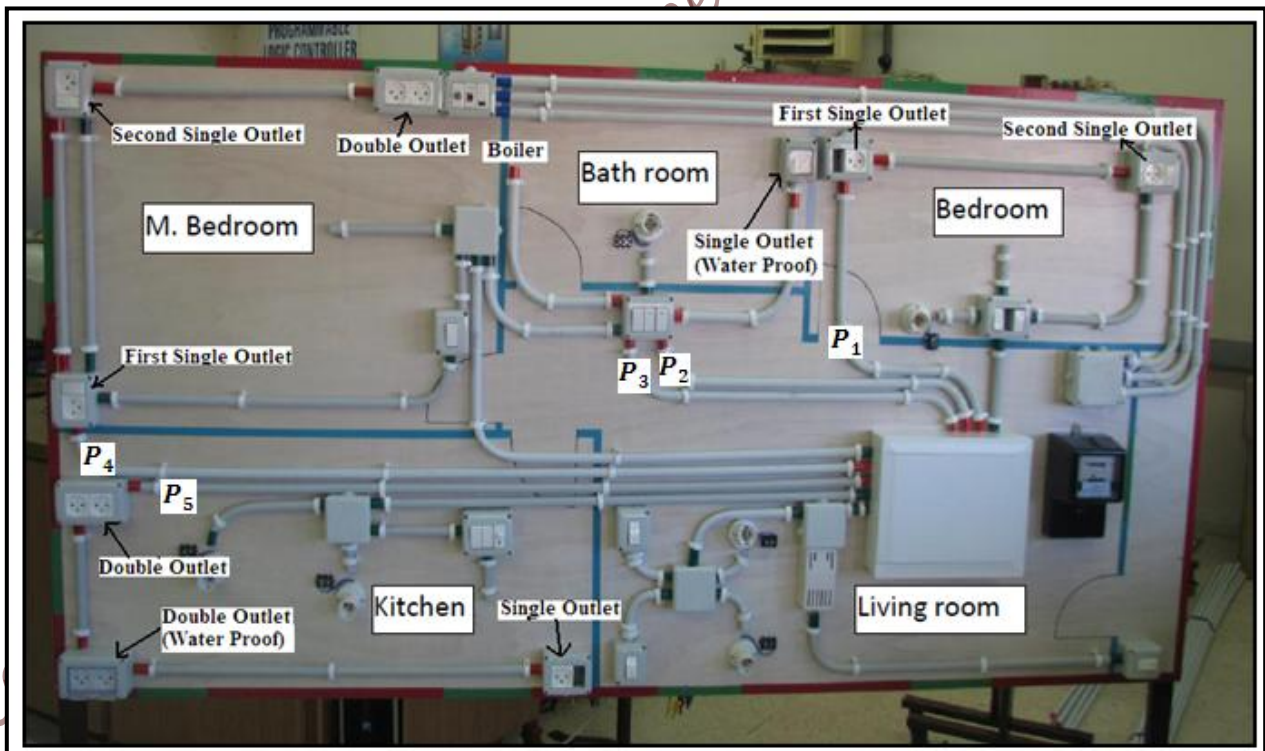

Figure 10.9: A photo of conduits, installations, and wiring in a symbolic flat consisting of a living room, a bedroom, a master bedroom, a bathroom and a kitchen

### **Task # 2: Master Bedroom Power Installations**

The power in the master bedroom will be represented by two single socket outlets and one double socket outlet. In this task, all the socket outlets were already installed in the room, as shown in Figure 10.9. To implement the wiring diagram of outlets, follow the following steps (**note that all wires in the same conduit should be run simultaneously**):

1. Disassemble all socket outlets in the room
2. Run a blue 2.5mm<sup>2</sup> wire from the DB neutral bus-bar to the first single socket outlet
3. Repeat step 2 for a yellow with green stripes conductor for the earth
4. Run a brown wire for the phase from P<sub>4</sub> – MCB output to the first single socket outlet; all the 3 wires should be run together.
5. Run a blue 2.5mm<sup>2</sup> wire from the first single socket outlet to the second single socket
6. Repeat step 5 for a yellow with green stripes conductor for the earth
7. Run a brown wire from the first single socket outlet to the second single socket outlet; all the 3 wires should be run together.
8. Run a blue 2.5mm<sup>2</sup> wire from the second single socket outlet to the double socket
9. Repeat step 8 for a yellow with green stripes for the earth conductor
- 10. Run a brown wire from the second single socket outlet to the double socket outlet; all the 3 wires should be run together.**
11. Connect the wires to socket pins, **note that all sockets are connected in parallel.**
- 12. Ask your lab supervisor to check connections!**
13. After finishing the power installations, assemble all the socket outlets again

### **Task # 3: Bathroom Power Installations**

A water proof (WP) socket outlet and a boiler point will be installed in the bathroom, each will be controlled by a double-pole single-throw switch with indication lamp. In this task, the WP socket outlet was already installed in the room, as shown in Figure 10.9. To implement the wiring diagram of switches and outlets, follow the following steps (**note that all wires in the same conduit should be run simultaneously**):

1. Disassemble the WP socket outlet in the bathroom
2. Run a blue 2.5mm<sup>2</sup> wire from the DB neutral bus-bar to a double-pole single-throw switch
3. Run a yellow with green stripes 2.5mm<sup>2</sup> wire from the DB earth bus-bar directly to the WP single socket outlet
4. Run a brown wire for the phase from P<sub>2</sub> – MCB output to the double-pole single-throw switch; **all the 3 wires should be run together.**
5. Run a blue 2.5mm<sup>2</sup> wire from the double-pole single-throw to the WP socket outlet
6. Run a brown wire for the phase from the double-pole single-throw switch to the water proof socket outlet; **the 3 wires should be run together.**
7. Run a blue 2.5mm<sup>2</sup> wire from the DB neutral bus-bar to the boiler double-pole single-throw switch
8. Run a yellow with green stripes 2.5mm<sup>2</sup> wire from the DB earth bus-bar directly to the boiler earth terminal block
9. Run a brown wire for the phase from P<sub>3</sub> – MCB output to the boiler double-pole single-throw switch; **all the 3 wires should be run together.**
10. Run a blue 2.5mm<sup>2</sup> wire from the boiler double-pole single-throw switch to the boiler neutral terminal block
11. Run a brown wire for the phase from the boiler double-pole single-throw switch to the boiler phase terminal block; **all 3 wires should be run together.**
12. Connect the wires to the switch, WP socket outlet, MCBs, and terminal block pins.
- 13. Ask your lab supervisor to check connections!**
14. After finishing the power installations, assemble all the switches and outlets again



#### **Task # 4: Kitchen Power Installations**

The power in the kitchen will be represented by one single socket outlet and two double socket outlets (one of them is water proof (WP) double socket outlet). In this task, all the socket outlets were already installed in the kitchen, as shown in Figure 10.9. To implement the wiring diagram of outlets, follow the following steps (**note that all wires in the same conduit should be run simultaneously**):

1. Disassemble all outlets in the room
2. Run a blue 2.5mm<sup>2</sup> wire from the DB neutral bus-bar to the first double socket outlet
3. Repeat step 2 for a yellow with green stripes conductor for the earth
4. Run a brown wire for the phase from P<sub>5</sub> – MCB output to the first double socket outlet;  
**all the 3 wires should be run together.**
5. Run a blue 2.5mm<sup>2</sup> wire from the first double socket outlet to the second (WP) double socket outlet
6. Repeat step 5 for a yellow with green stripes conductor for the earth
7. Run a brown wire from the first double socket outlet to the second (WP) double socket outlet;  
**all the 3 wires should be run together.**
8. Run a blue 2.5mm<sup>2</sup> wire from the second (WP) double socket outlet to the single socket
9. Repeat step 8 for a yellow with green stripes conductor for the earth
10. Run a brown wire from the second (WP) double socket outlet to the single socket outlet;  
**all the 3 wires should be run together.**
11. Connect the wires to socket pins and MCBs, **note that all sockets are connected in parallel.**
12. **Ask your lab supervisor to check connections!**
13. After finishing the power installations, assemble all the socket outlets again

*Electrical and Computer Engineering Department-BZU, 2015*



## Experiment # 11

### Introduction to Three-Phase Installations

#### ➤ **Objectives:**

The main objectives of this experiment are:

1. To be introduced to different 3 phase household devices and instruments
2. To be introduced to the connection of 3 phase distribution board
3. To be introduced to the distribution of 3 phase loads in 3 phase system

#### ➤ **Prelab:**

Print the lighting diagram, power diagram for the designed premises of experiment 5, which you submitted as assignment 5.

#### ➤ **Theory:**

Three phase systems are required when you want to receive a larger amount of power due to many appliances that you have within your premises, or because you may need it to operate 3 phase loads (motors). Three phase systems consist of 3 lines that carry the three phase currents, a Neutral that represent the return path for any currents due to unbalanced loads and the Earth conductor that is usually connected locally within your premises. The Earth conductor may be connected to the premises steel grid (frame) to ensure good conductive and low resistive path to the ground. Each 3 phase line will provide a certain amount of current. Assuming a balanced input source (which is what supposed to be), you should be aware of the maximum current that is provided by the electricity company, this differs from one place to another according to local regulations.

In distributing the loads on the 3 phase source, you should take into account several factors, first, the loads should be distributed as balanced as possible. This will ensure safe operation and will prevent over-current situations from happening and so causing any kind of damage to the equipments. In order to distribute the loads in a balanced way, you should estimate the current which each load is going to consume. Depending on the load type, the line current for a single phase is:

$$I_l = \frac{P}{V_\phi PF} \dots\dots\dots 11.1$$

And for 3 phase load, the line current is:

$$I_l = \frac{P}{\sqrt{3}V_l PF} \dots\dots\dots 11.2$$

where:

$I_l$ : is the load current

$V_l$ : is the line to line voltage

PF: is the power factor

P: is the load power

Three phase main Distribution boards usually consist of 5 bus bars, the 3 phase bus-bars, the Neutral bus-bar and the Earth bus-bar. For a three phase consumer, the main 3 phase lines are connected directly to a 3 phase manual breaker, and then the 3 phase lines are connected to a 3 phase kWh meter, then to a 3 phase circuit breaker and to a 3 phase EL (RCD). Then, the 3 phase lines will be distributed into the bus bars within the main distribution board; cables will connect the main Bus-Bars to Distribution boards within the premises.



Figure 11.1: Three-Phase Residual Current Device and Three-phase Miniature Circuit Breaker

For a building consisting of departments, each department will have its own single phase kWh, MCB and the lines will be distributed to the department's distribution boards.

Power factor correction is an important issue in 3 phase installation; the Electricity regulating authorities specify a minimum power factor. The engineer should be aware that if the power factor is below the predefined value (usually 0.92), extra cost will be paid as a compensation for the losses, or the company may refuse to provide electrical power. Power factor correction equipments may be needed to improve the power factor.

➤ **Procedure:**

**A. Familiarization with Three Phase Instruments:**

**1. Three-Phase kWh meter:**

It consists of 3 phase inputs for each 3 phase lines ( $L_1$ ,  $L_2$  and  $L_3$ ) and 3 phase outputs of each line. It will also consist of an input/output for the Neutral line and an input/output for the Earth conductor. The connection of kWh meters differs between manufacturers and the datasheet (the device manual) should be consulted first. Figure 11.2 shows a typical 3phase kWh meter.

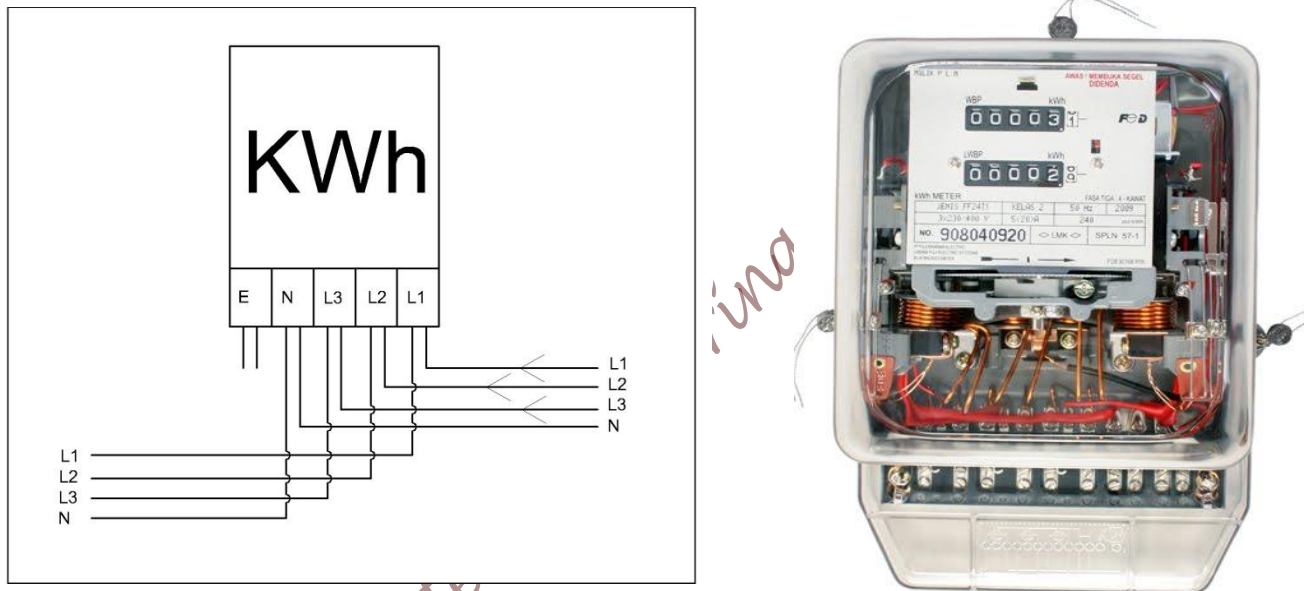

Figure 11.2: Three-phase kWh meter

**2. Three phase Miniature Circuit Breaker (MCB)**

It consists of 3 inputs and 3 outputs. The three input are the 3 phase lines, whilst the three outputs are the 3 phase feeders or load terminals. Some breakers will have a common node for the neutral line. It operates if the current in one line exceeded the pre-set value; the breaker will interrupt the current flow and the source will be isolated from the load. MCBs differ according to their purpose, rating and functionality. Figure 11.3 shows a typical three phase MCB.



Figure 11.3: A typical Three-phase Miniature Circuit Breaker

### 3. Three Phase Residual Current Device (RCD) or Earth Leakage (EL)

It consists of 4 inputs and 4 outputs. The four inputs are the 3 phase lines and the Neutral, the four outputs are the 3 phase load terminals and the neutral. It operates as if the current sum in the three phase lines should equal to the return current in the Neutral, this will be detected using magnetic field mechanism. If the magnetic field produced by the sum of the current in the three phase lines is equal to the magnetic field produced by the return current, no fault is recorded. And if the difference exceeds a threshold value (30mA, 100mA or 300mA ...) the RCD will trip isolating the main source from the load and so preventing more damage to the system or shock risks. Figure 11.4 shows a typical three phase RCD.



Figure 11.4: A typical Three-phase Residual Current Device

### 4. Fuses

It was explained in earlier experiments that fuses are sacrificial devices that if the current exceeds the operating current of the fuse, the filament of the fuse will melt and an open circuit

will occur. A fuse is usually inserted in 3 phase wiring along each line for extra protection in case of failure of other protection devices. Figure 11.5 shows a typical medium voltage fuse.



Figure 11.5: A typical medium voltage fuse

### 5. Three Phase Cables

As the name indicates, three phase cables are used to connect the main electricity grid lines to the household. They usually consist of four lines, 3 lines for the main 3 phase conductors and the fourth



Figure 11.6: Examples of three phase cables

line for the Neutral, the Neutral is usually of smaller cross sectional area. The color code depends on the manufacturer of the cable but usually RED, Yellow and Blue are the 3 phase lines, and the Neutral is the Black one. The cross sectional area for three phase cables is 6, 10, 16, 25, 35, 50,

70, 95 and 120 mm<sup>2</sup>. These three phase wires are wrapped with a guided plastic cover (green or white). Table 11.1 shows conductor specifications based on the conductor cross sectional area.

**Table 11.1:** Specifications of single core wires of 650V rating

Cond. Area Sq. mm	Conductor Construction No./ Dia	Max. DC Conductor Resistance at 20°C in ohm / km		Unsheathed Cables		Sheathed Cables			Current Rating Amp	
		Copper	Aluminum	Insulation thickness	Overall Diameter	Insulation thickness	Sheath thickness	Overall Diameter	Copper	Aluminum
1	01/01/12	17.7	-	0.7	2.6	0.6	0.8	4.1	10	8
1.5	01/01/38	11.9	19.7	0.7	2.9	0.6	0.8	4.4	13	10
2.5	01/01/78	7.14	11.8	0.8	3.5	0.7	0.8	5	20	15
4	01/02/24	4.47	7.39	0.8	4	0.8	0.9	5.85	26	20
6	01/02/76	2.97	4.91	0.8	4.5	0.8	0.9	6.4	35	27
10	01/3.55 Al	01/08/09	2.94	1	5.7	1	0.9	7.55	44	34
	7/1.35 Cu	-	-	-	6.2	-	-	8.05	45	35
16	07/01/70	1.13	1.87	1	7.2	1	1	9.3	55	43
25	07/02/14	0.71	1.18	1.2	8.9	1.2	1.1	11.2	75	58
35	07/02/50	0.51	0.85	1.2	10	1.2	1.1	12.3	90	70
50	07/3.00	0.38	0.63	1.4	11.9	1.4	1.2	14.4	120	92
	19/1.78	-	-	-	11.9	1.4	1.2	14.4	120	92
70	19/2.14	0.26	0.44	1.4	13.6	-	-	-	150	116
95	19/2.50	0.19	0.31	1.6	15.8	-	-	-	175	135
120	02/03/37	0.15	0.25	1.6	17.5	-	-	-	200	155
150	02/24/37	0.12	0.2	1.8	19.4	-	-	-	230	175
185	37/2.50	0.1	0.16	2	21.7	-	-	-	265	205

## 6. Other Components

In factories, it is essential to maintain a good record of the voltage, the current, power factor and the reactive power. Meters to records, these values are usually installed in the main distribution board. The method of connecting these instruments should be obvious for electrical engineers. The ammeters rely on current transformers to measure the current. The voltmeters are connected in parallel between any two lines to measure the line to line voltage. Power factor meters are connected in away to measure the current, and the voltage between the line and the neutral, with a certain mechanism; it provides the value of the power factor.

## B. Three Phase Distribution Boards

As stated earlier, distribution boards will have five bus bars, kWh meter, three phase MCB, 3 phase RCD, required fuses and any auxiliary components for measurement, Figure 11.7 shows a typical 3 phase distribution boards for a building that has several floors.

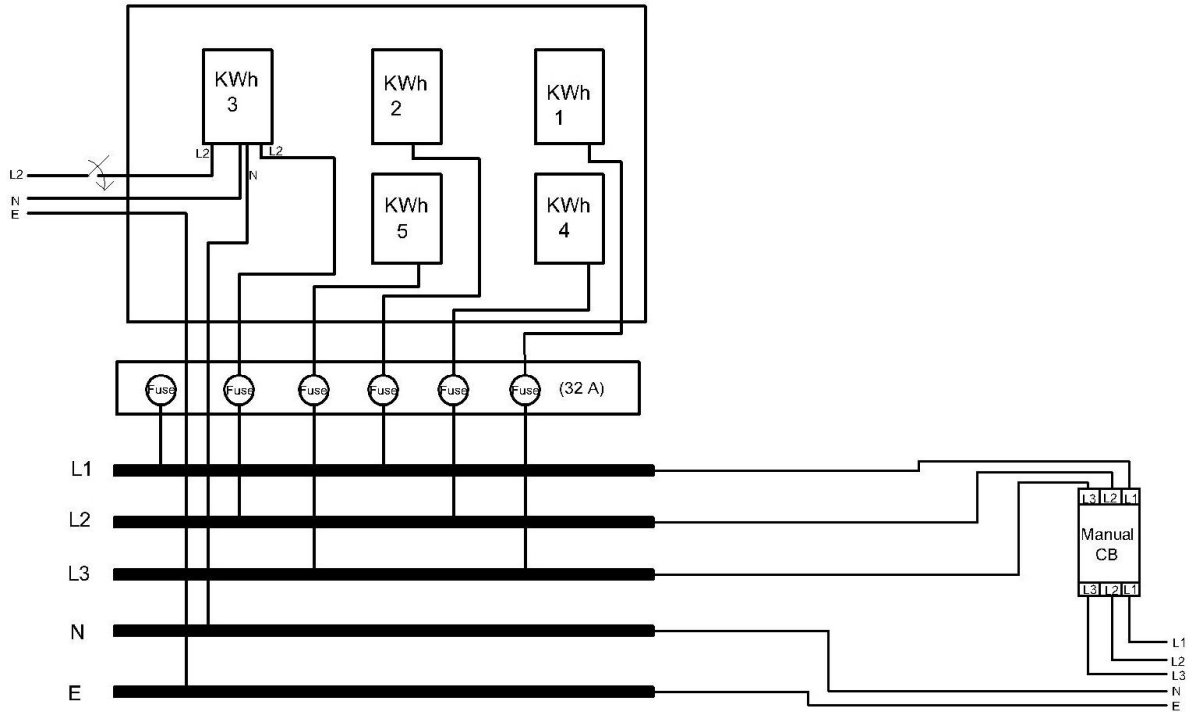

Figure 11.7: Three phase distribution board for a building with several flats

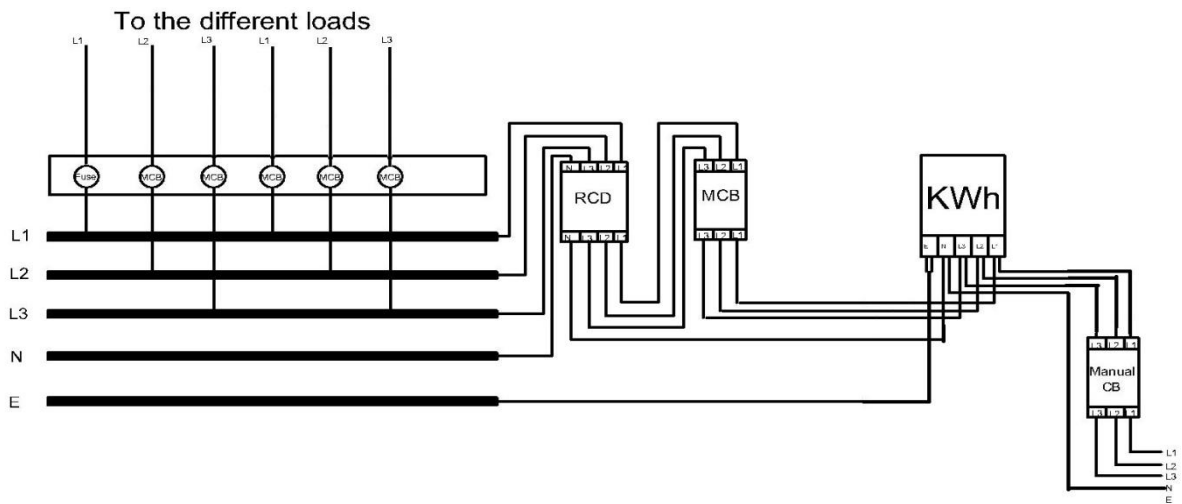

Figure 11.8: Three phase distribution board for a building owned by a single user

Three Phase Distribution boards for factories or for a single user must have a three phase CB, a three phase RCD, a three phase kWh meter and single phase MCBs to provide the different loads as illustrated in Figure 11.8.

### C. Load Distribution in Three Phase Systems

Using the power relationships that you already know, and assuming that the overall power factor of the premises designed in Experiment 5 (the power diagram and the light diagram) is 0.95, estimate the current supplied by each phase and see if this makes an even distribution of load in the system, assume that each light rated power is 40W, assume the DJ consumes 300W, and each channel connected to the DJ consumes 800W, Air conditions about 2kW each. If there are any other appliances, you can just assume the power consumption (as a demonstration only).

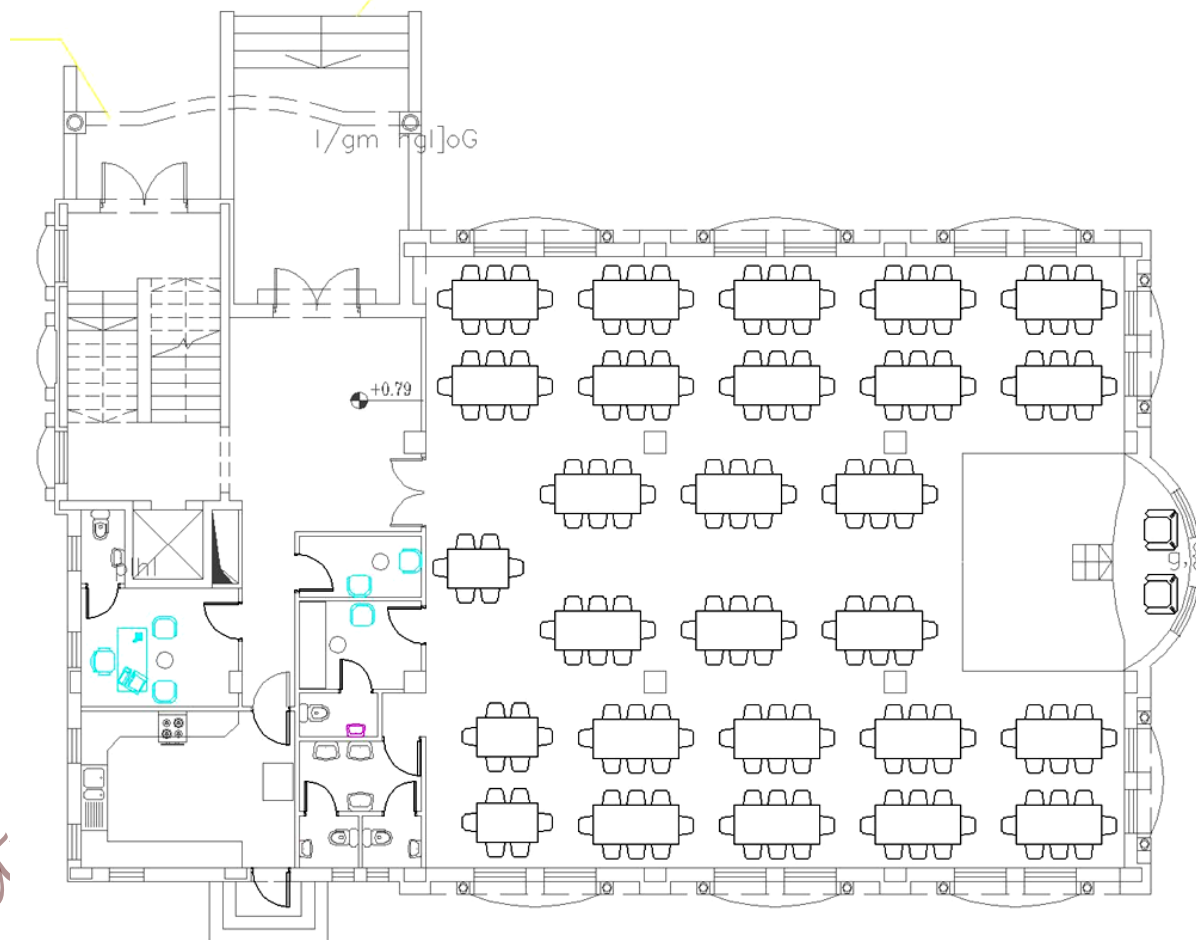

Figure 11.9: The premises designed in Experiment 5 required for balanced load distribution