

Balanced and Unbalanced Faults

■ Fault Analysis

- » An essential part of a power network is the calculation of the currents which flow in the components when faults of various types occur.
- » In a fault survey, faults are applied at various points in the network and the resulting currents obtained by hand calculation, or, most likely now on large networks, by computer software.
- » The magnitude of the fault currents give the engineer the current settings for the protection to be used and the ratings of the circuit breakers.

» Types of Short Circuit:

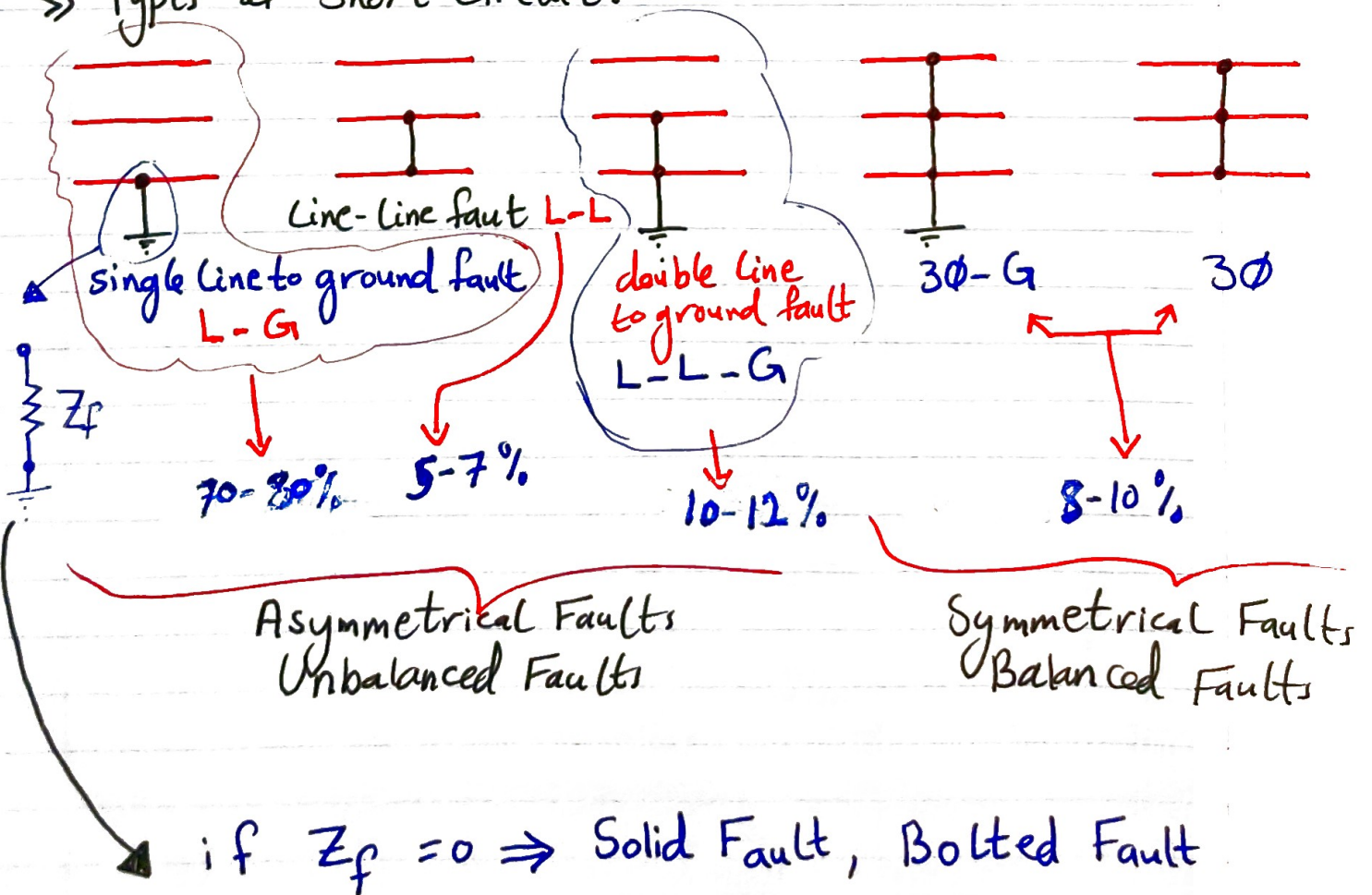

- » The most common of these faults is the short circuit of a single phase to ground fault.
- » Often the path to ground contains resistance in the form of an arc as shown in the previous figure.
- » Although the single line to ground fault is the most common, calculations are frequently performed to 3 ϕ faults.
- » 3 ϕ faults (Balanced faults) are the most severe fault and easy to calculate.
- » The problem consists of determining bus voltages and line currents during various types of faults.

9.2 BALANCED THREE-PHASE FAULT

1) This type of fault is defined as the simultaneous short circuit across all three phases. It occurs infrequently, but it is the most severe type of fault encountered. Because the network is balanced, it is solved on a per-phase basis. The other two phases carry identical currents except for the phase shift.

2) The reactance of the synchronous generator under short-circuit conditions is a time-varying quantity, and for network analysis three reactances were defined. The subtransient reactance X''_d , for the first few cycles of the short circuit current, transient reactance X'_d , for the next (say) 30 cycles, and the synchronous reactance X_d , thereafter. Since the duration of the short circuit current depends on the time of operation of the protective system, it is not always easy to decide which reactance to use. Generally, the subtransient reactance is used for determining the interrupting capacity of the circuit breakers. In fault studies required for relay setting and coordination, transient reactance is used. Also, in typical transient stability studies, transient reactance is used.

3) A fault represents a structural network change equivalent with that caused by the addition of an impedance at the place of fault. If the fault impedance is zero, the fault is referred to as the *bolted fault* or the *solid fault*. The faulted network can be solved conveniently by the Thévenin's method. The procedure is demonstrated in the following example.

Example 9.1 (chp9ex1)

The one-line diagram of a simple three-bus power system is shown in Figure 9.1. Each generator is represented by an emf behind the transient reactance. All impedances are expressed in per unit on a common 100 MVA base, and for simplicity, resistances are neglected. The following assumptions are made.

- (i) Shunt capacitances are neglected and the system is considered on no-load.
- (ii) All generators are running at their rated voltage and rated frequency with their emfs in phase.

Determine the fault current, the bus voltages, and the line currents during the fault when a balanced three-phase fault with a fault impedance $Z_f = 0.16$ per unit occurs on

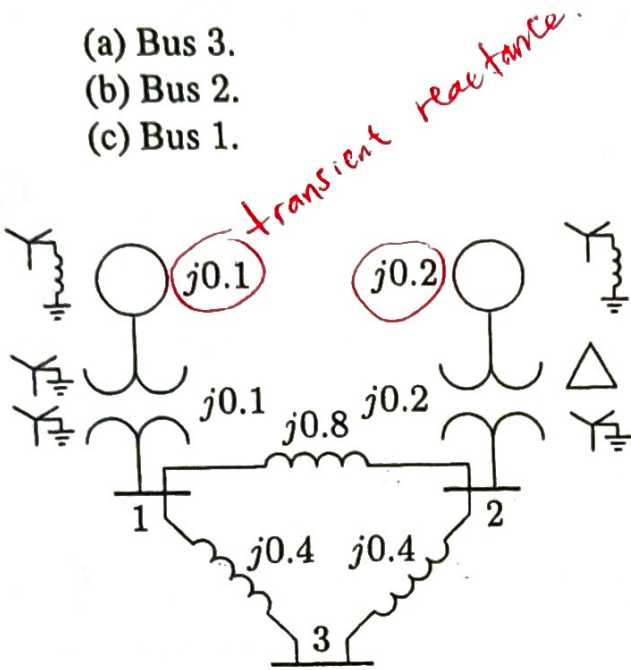

FIGURE 9.1
 The impedance diagram of a simple power system.

The fault is simulated by switching on an impedance Z_f at bus 3 as shown in Figure 9.2(a). Thévenin's theorem states that the changes in the network voltage caused by the added branch (the fault impedance) shown in Figure 9.2(a) is equivalent to those caused by the added voltage $V_3(0)$ with all other sources short-circuited as shown in Figure 9.2(b).

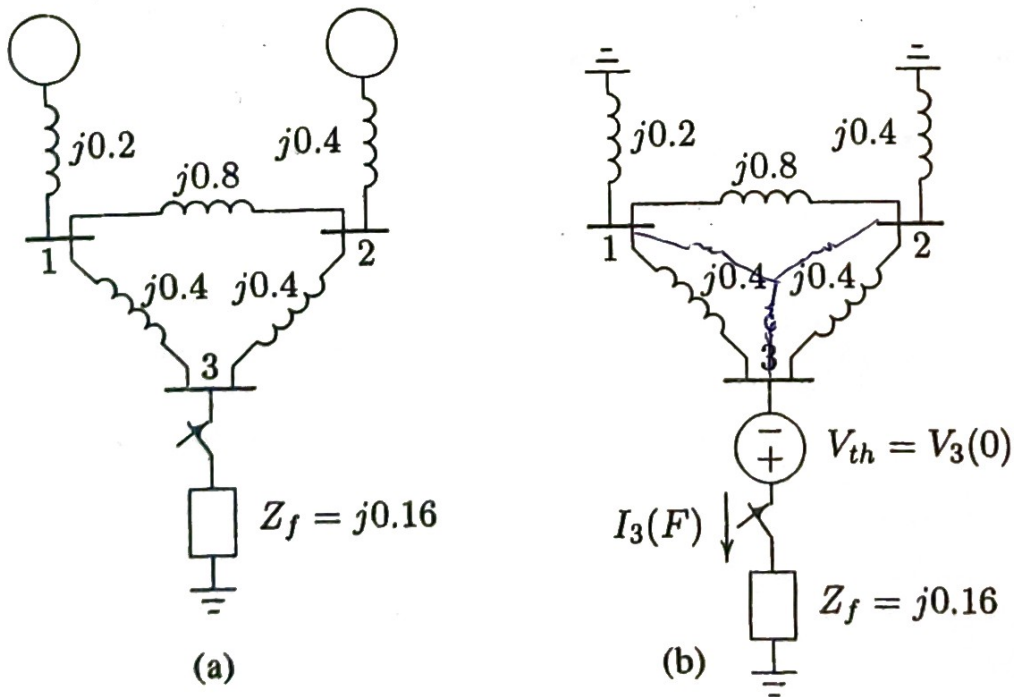

FIGURE 9.2
 (a) The impedance network for fault at bus 3. (b) Thévenin's equivalent network.

(a) From 9.2(b), the fault current at bus 3 is

$$I_3(F) = \frac{V_3(0)}{Z_{33} + Z_f}$$

where $V_3(0)$ is the Thévenin's voltage or the prefault bus voltage. The prefault bus voltage can be obtained from the results of the power flow solution. In this example, since the loads are neglected and generator's emfs are assumed equal to the rated value, all the prefault bus voltages are equal to 1.0 per unit, i.e.,

$$V_1(0) = V_2(0) = V_3(0) = 1.0 \text{ pu}$$

Z_{33} is the Thévenin's impedance viewed from the faulted bus.

To find the Thévenin's impedance, we convert the Δ formed by buses 123 to an equivalent Y as shown in Figure 9.3(a).

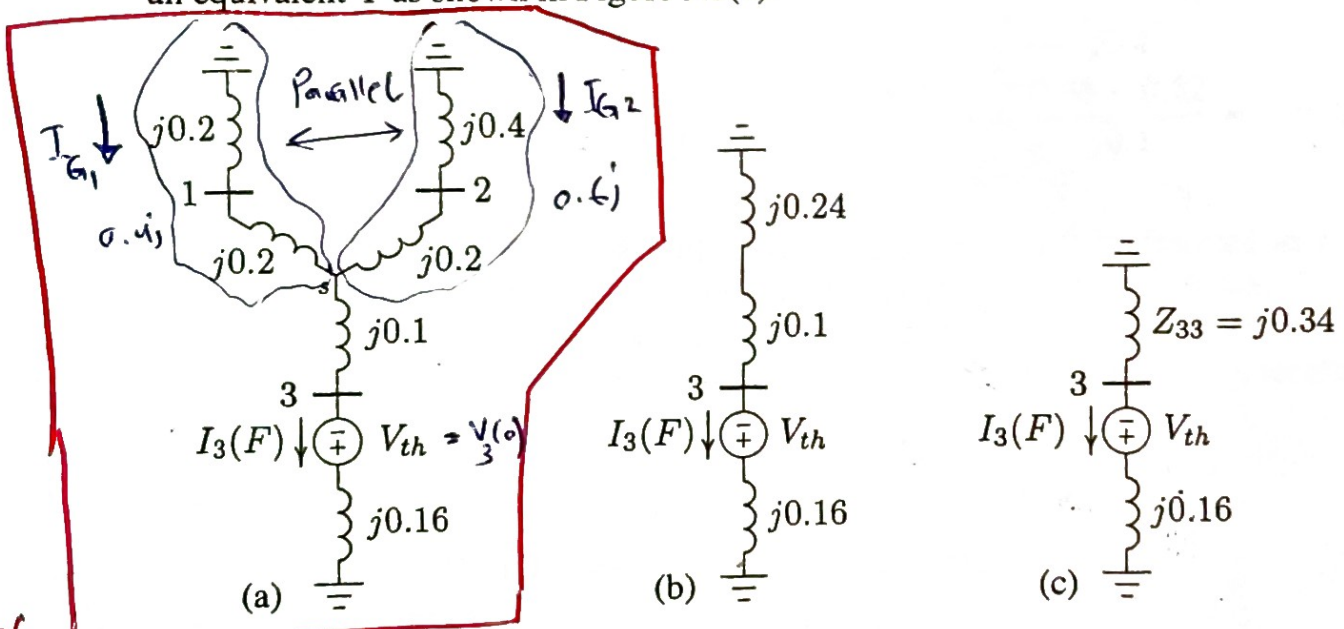

FIGURE 9.3 Reduction of Thévenin's equivalent network.

$$Z_{1s} = Z_{2s} = \frac{(j0.4)(j0.8)}{j1.6} = j0.2 \quad Z_{3s} = \frac{(j0.4)(j0.4)}{j1.6} = j0.1$$

Combining the parallel branches, Thévenin's impedance is

$$\begin{aligned} Z_{33} &= \frac{(j0.4)(j0.6)}{j0.4 + j0.6} + j0.1 \\ &= j0.24 + j0.1 = j0.34 \end{aligned}$$

From Figure 9.3(c), the fault current is

$$I_3(F) = \frac{V_3(0)}{Z_{33} + Z_f} = \frac{1.0}{j0.34 + j0.16} = -j2.0 \text{ pu}$$

With reference to Figure 9.3(a), the current divisions between the two generators are

$$2) \quad I_{G1} = \frac{j0.6}{j0.4 + j0.6} I_3(F) = -j1.2 \text{ pu}$$

$$I_{G2} = \frac{j0.4}{j0.4 + j0.6} I_3(F) = -j0.8 \text{ pu}$$

For the bus voltage changes from Figure 9.3(b), we get

$$3) \quad \Delta V_1 = 0 - (j0.2)(-j1.2) = -0.24 \text{ pu}$$

$$\Delta V_2 = 0 - (j0.4)(-j0.8) = -0.32 \text{ pu}$$

$$\Delta V_3 = (j0.16)(-j2) - 1.0 = -0.68 \text{ pu}$$

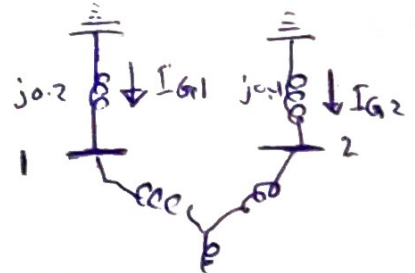

4) ✗ The bus voltages during the fault are obtained by superposition of the prefault bus voltages and the changes in the bus voltages caused by the equivalent emf connected to the faulted bus, as shown in Figure 9.2(b), i.e.,

$$V_1(F) = V_1(0) + \Delta V_1 = 1.0 - 0.24 = 0.76 \text{ pu}$$

$$V_2(F) = V_2(0) + \Delta V_2 = 1.0 - 0.32 = 0.68 \text{ pu}$$

$$V_3(F) = V_3(0) + \Delta V_3 = 1.0 - 0.68 = 0.32 \text{ pu}$$

5) ✗ The short circuit-currents in the lines are

$$I_{12}(F) = \frac{V_1(F) - V_2(F)}{z_{12}} = \frac{0.76 - 0.68}{j0.8} = -j0.1 \text{ pu}$$

$$I_{13}(F) = \frac{V_1(F) - V_3(F)}{z_{13}} = \frac{0.76 - 0.32}{j0.4} = -j1.1 \text{ pu}$$

$$I_{23}(F) = \frac{V_2(F) - V_3(F)}{z_{23}} = \frac{0.68 - 0.32}{j0.4} = -j0.9 \text{ pu}$$

(b) The fault with impedance Z_f at bus 2 is depicted in Figure 9.4(a), and its Thévenin's equivalent circuit is shown in Figure 9.4(b). To find the Thévenin's impedance, we combine the parallel branches in Figure 9.4(b). Also, combining parallel branches from ground to bus 2 in Figure 9.5(a), results in

$$Z_{22} = \frac{(j0.6)(j0.4)}{j0.6 + j0.4} = j0.24$$

From Figure 9.5(b), the fault current is

$$I_2(F) = \frac{V_2(0)}{Z_{22} + Z_f} = \frac{1.0}{j0.24 + j0.16} = -j2.5 \text{ pu}$$

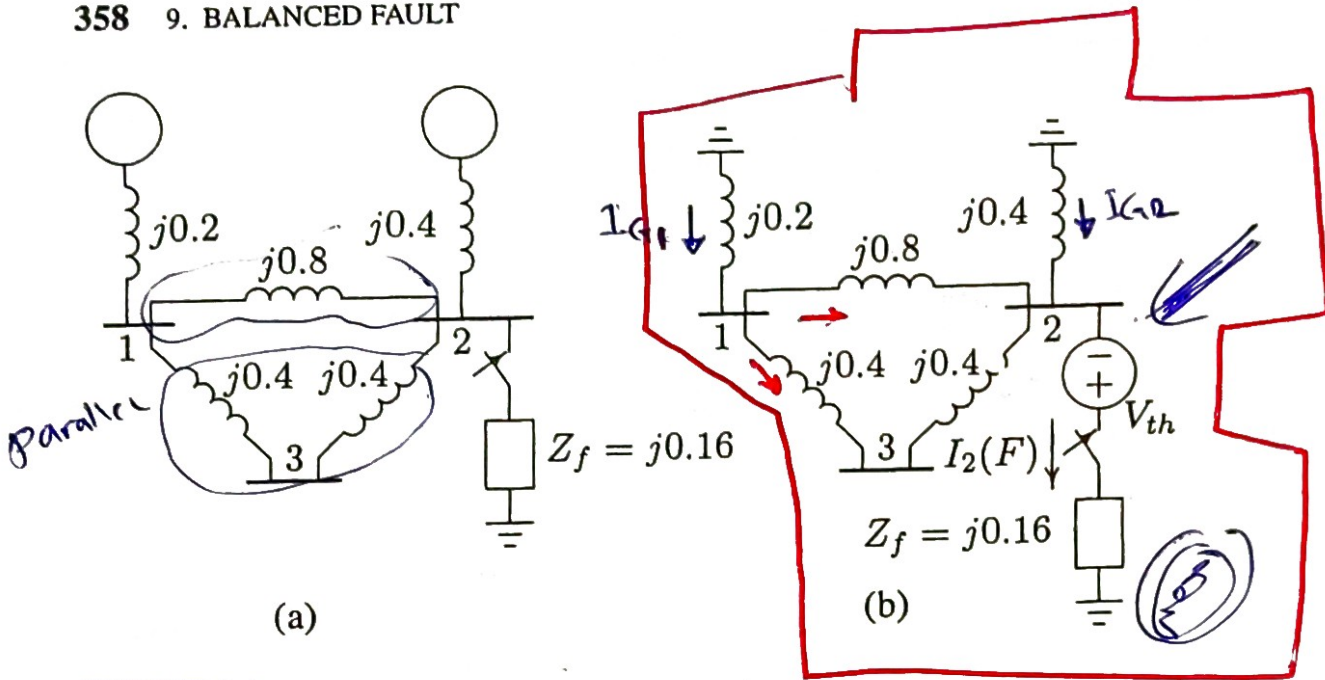

FIGURE 9.4
 (a) The impedance network for fault at bus 2. (b) Thévenin's equivalent network.

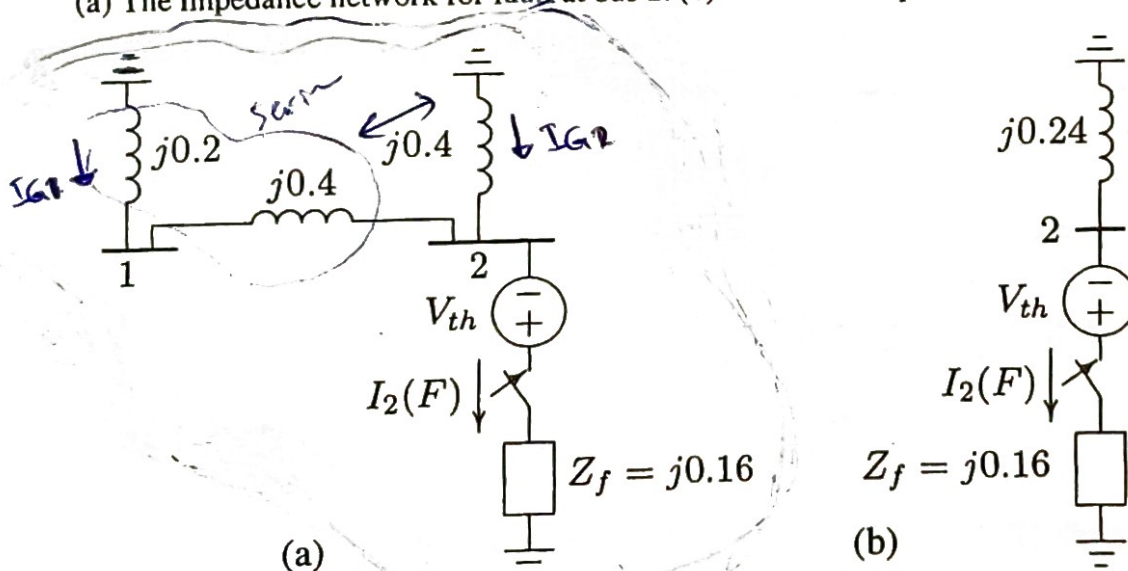

FIGURE 9.5
 Reduction of Thévenin's equivalent network.

With reference to Figure 9.5(a), the current divisions between the generators are

$$I_{G1} = \frac{j0.4}{j0.4 + j0.6} I_2(F) = -j1.0 \text{ pu}$$

$$I_{G2} = \frac{j0.6}{j0.4 + j0.6} I_2(F) = -j1.5 \text{ pu}$$

For the bus voltage changes from Figure 9.4(a), we get

$$\Delta V_1 = 0 - (j0.2)(-j1.0) = -0.2 \text{ pu}$$

$$\Delta V_2 = 0 - (j0.4)(-j1.5) = -0.6 \text{ pu}$$

$$\Delta V_3 = -0.2 - (j0.4)\left(\frac{-j1.0}{2}\right) = -0.4 \text{ pu}$$

The bus voltages during the fault are obtained by superposition of the prefault bus voltages and the changes in the bus voltages caused by the equivalent emf connected to the faulted bus, as shown in Figure 9.4(b), i.e.,

$$V_1(F) = V_1(0) + \Delta V_1 = 1.0 - 0.2 = 0.8 \text{ pu}$$

$$V_2(F) = V_2(0) + \Delta V_2 = 1.0 - 0.6 = 0.4 \text{ pu}$$

$$V_3(F) = V_3(0) + \Delta V_3 = 1.0 - 0.4 = 0.6 \text{ pu}$$

The short circuit-currents in the lines are

$$I_{12}(F) = \frac{V_1(F) - V_2(F)}{z_{12}} = \frac{0.8 - 0.4}{j0.8} = -j0.5 \text{ pu}$$

$$I_{13}(F) = \frac{V_1(F) - V_3(F)}{z_{13}} = \frac{0.8 - 0.6}{j0.4} = -j0.5 \text{ pu}$$

$$I_{32}(F) = \frac{V_3(F) - V_2(F)}{z_{32}} = \frac{0.6 - 0.4}{j0.4} = -j0.5 \text{ pu}$$

(c) The fault with impedance Z_f at bus 1 is depicted in Figure 9.6(a), and its Thévenin's equivalent circuit is shown in Figure 9.6(b).

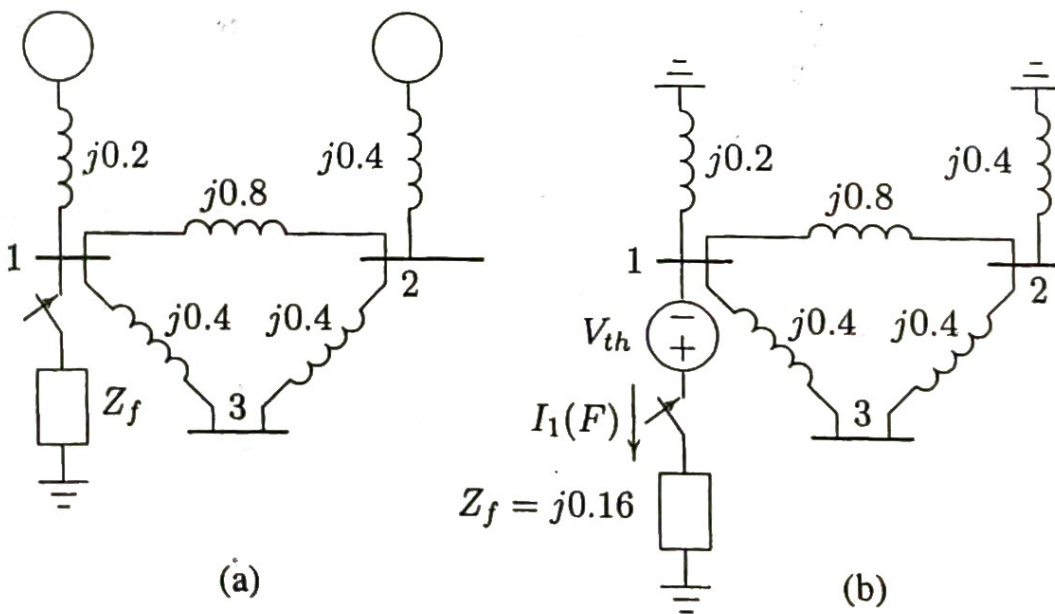

FIGURE 9.6

(a) The impedance network for fault at bus 1. (b) Thévenin's equivalent network.

To find the Thévenin's impedance, we combine the parallel branches in Figure 9.6(b). Also, combining parallel branches from ground to bus 1 in Figure 9.7(a),

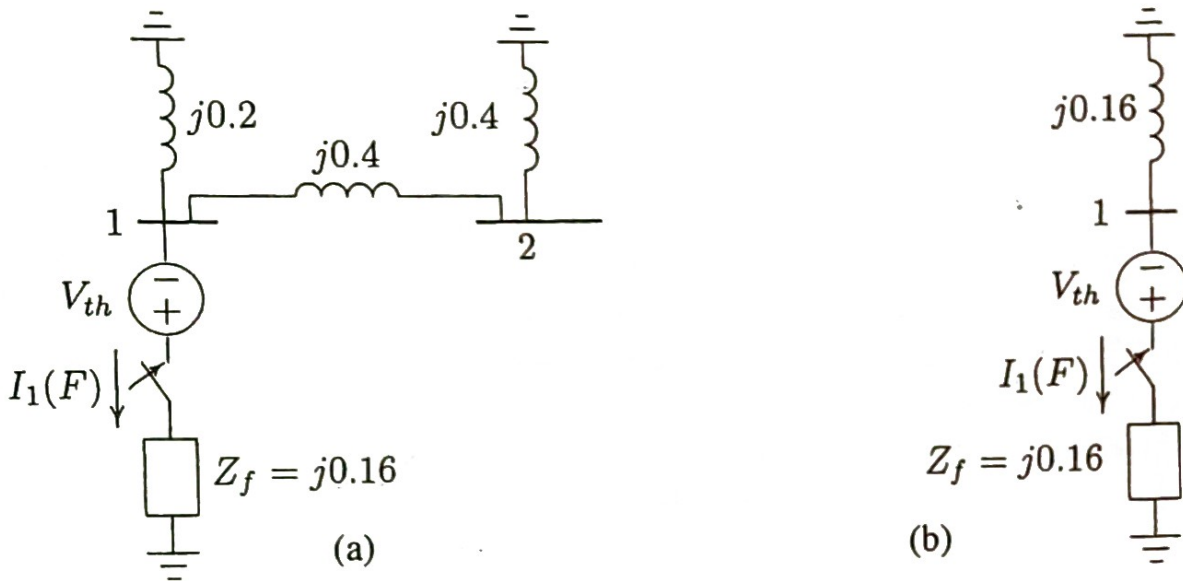

FIGURE 9.7
Reduction of Thévenin's equivalent network.

results in

$$Z_{11} = \frac{(j0.2)(j0.8)}{j0.2 + j0.8} = j0.16$$

From Figure 9.7(b), the fault current is

$$I_1(F) = \frac{V_1(0)}{Z_{11} + Z_f} = \frac{1.0}{j0.16 + j0.16} = -j3.125 \text{ pu}$$

With reference to Figure 9.7(a), the current divisions between the two generators are

$$I_{G1} = \frac{j0.8}{j0.2 + j0.8} I_2(F) = -j2.50 \text{ pu}$$

$$I_{G2} = \frac{j0.2}{j0.2 + j0.8} I_2(F) = -j0.625 \text{ pu}$$

For the bus voltage changes from Figure 9.6(b), we get

$$\Delta V_1 = 0 - (j0.2)(-j2.5) = -0.50 \text{ pu}$$

$$\Delta V_2 = 0 - (j0.4)(-j0.625) = -0.25 \text{ pu}$$

$$\Delta V_3 = -0.5 + (j0.4)\left(\frac{-j0.625}{2}\right) = -0.375 \text{ pu}$$

Bus voltages during the fault are obtained by superposition of the prefault bus voltages and the changes in the bus voltages caused by the equivalent emf connected

to the faulted bus, as shown in Figure 9.6(b), i.e.,

$$V_1(F) = V_1(0) + \Delta V_1 = 1.0 - 0.50 = 0.50 \text{ pu}$$

$$V_2(F) = V_2(0) + \Delta V_2 = 1.0 - 0.25 = 0.75 \text{ pu}$$

$$V_3(F) = V_3(0) + \Delta V_3 = 1.0 - 0.375 = 0.625 \text{ pu}$$

The short-circuit currents in the lines are

$$I_{21}(F) = \frac{V_2(F) - V_1(F)}{z_{21}} = \frac{0.75 - 0.5}{j0.8} = -j0.3125 \text{ pu}$$

$$I_{31}(F) = \frac{V_3(F) - V_1(F)}{z_{31}} = \frac{0.625 - 0.5}{j0.4} = -j0.3125 \text{ pu}$$

$$I_{23}(F) = \frac{V_2(F) - V_3(F)}{z_{23}} = \frac{0.75 - 0.625}{j0.4} = -j0.3125 \text{ pu}$$

Notes:-

1) In the above example the load currents were neglected and all prefault bus voltages were assumed to be equal to 1.0 per unit. For more accurate calculation, the prefault bus voltages can be obtained from the power flow solution. ~~As we have seen in Chapter 6, in a power system, loads are specified and the load currents are unknown.~~ One way to include the effects of load currents in the fault analysis is to express the loads by a constant impedance evaluated at the prefault bus voltages. ~~This is a very good approximation which results in linear nodal equations.~~ The procedure is summarized in the following steps.

- The prefault bus voltages are obtained from the results of the power flow solution.
- In order to preserve the linearity feature of the network, loads are converted to constant admittances using the prefault bus voltages.
- The faulted network is reduced into a Thévenin's equivalent circuit as viewed from the faulted bus. Applying Thévenin's theorem, changes in the bus voltages are obtained.
- Bus voltages during the fault are obtained by superposition of the prefault bus voltages and the changes in the bus voltages computed in the previous step.
- The currents during the fault in all branches of the network are then obtained.

Short-Circuit Capacity (SCC):-

The SCC at a bus is a common measure of the strength of a bus. The SCC or the short-circuit MVA at bus k is defined as the product of the magnitude of the rated bus voltage and the fault current.

$$SCC = \sqrt{3} V_{LK} I_k(F) \times 10^{-3} \text{ MVA}$$

↑ expressed in amp.

↳ the line-to-line voltage expressed in KV

But

$$I_k(F) = I_k(F)_{pu} \times I_B \text{ base MVA}$$

$$= \boxed{I_k(F)_{pu}} \times \frac{S_B \times 10^3}{V_B \sqrt{3}}$$

Symmetrical 3- ϕ fault current in per unit.

$$= \frac{V_k(0)}{X_{kk}} \times \frac{S_B \times 10^3}{V_B \sqrt{3}}$$

↳ ~~base~~ L-L base voltage in KV

$$\boxed{I_k(F) = \frac{V_k(0)}{Z_{kk} + Z_f}}$$

$V_k(0)$: per unit pre-fault bus voltage

X_{kk} : is the per unit reactance to the point of fault.

System resistance is neglected

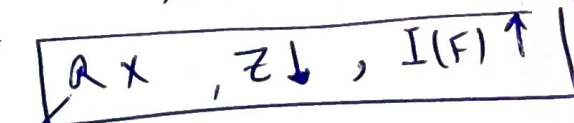

↳ good approx.

$$SCC = \frac{V_k(0) S_B \times 10^3}{X_{kk} V_B \sqrt{3}} \times \sqrt{3} V_{LK} \times 10^{-3} \text{ MVA}$$

$$= \frac{V_k(0) S_B V_{LK}}{X_{kk} V_B}$$

if $V_B = V_{LK}$
 $V_k(0) = 1 \text{ pu}$

$$\boxed{SCC \approx \frac{S_B}{X_{kk}} \text{ MVA}}$$