

# POWER SYSTEM ANALYSIS & DESIGN

5TH EDITION

J. Duncan Glover, Mulukutla S. Sarma & Thomas J. Overbye  
Solutions Manual

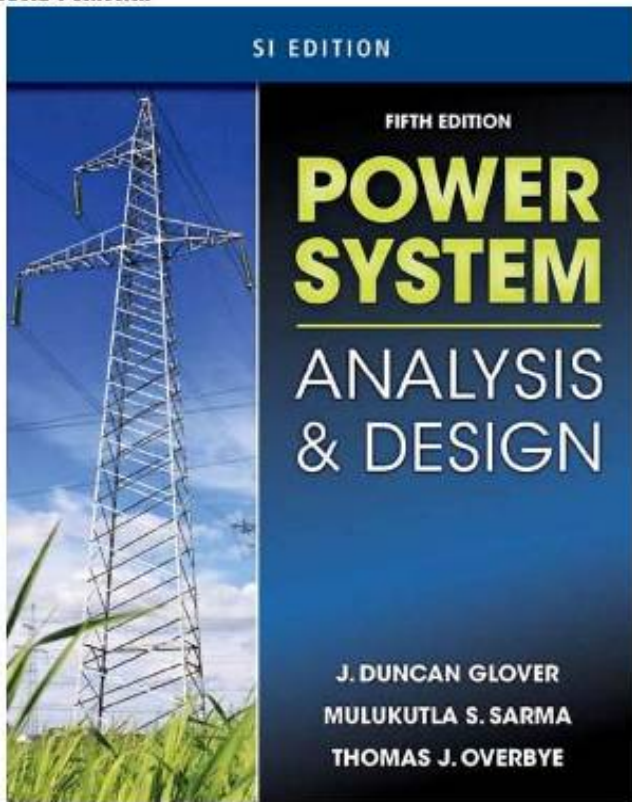

INSTRUCTOR'S SOLUTIONS MANUAL  
TO ACCOMPANY

# POWER SYSTEM ANALYSIS AND DESIGN

FIFTH EDITION

J. DUNCAN GLOVER  
MULUKUTLA S. SARMA  
THOMAS J. OVERBYE

# Contents

Chapter 2	1
Chapter 3	27
Chapter 4	71
Chapter 5	95
Chapter 6	137
Chapter 7	175
Chapter 8	195
Chapter 9	231
Chapter 10	303
Chapter 11	323
Chapter 12	339
Chapter 13	353
Chapter 14	379

## Chapter 2

### Fundamentals

#### ANSWERS TO MULTIPLE-CHOICE TYPE QUESTIONS

<b>2.1</b>	b	<b>2.19</b>	a
<b>2.2</b>	a	<b>2.20</b>	A. c
<b>2.3</b>	c		B. a
<b>2.4</b>	a		C. b
<b>2.5</b>	b	<b>2.21</b>	a
<b>2.6</b>	c	<b>2.22</b>	a
<b>2.7</b>	a	<b>2.23</b>	b
<b>2.8</b>	c	<b>2.24</b>	a
<b>2.9</b>	a	<b>2.25</b>	a
<b>2.10</b>	c	<b>2.26</b>	b
<b>2.11</b>	a	<b>2.27</b>	a
<b>2.12</b>	b	<b>2.28</b>	b
<b>2.13</b>	b	<b>2.29</b>	a
<b>2.14</b>	c	<b>2.30</b>	(i) c
<b>2.15</b>	a		(ii) b
<b>2.16</b>	b		(iii) a
<b>2.17</b>	A. a		(iv) d
	B. b	<b>2.31</b>	a
	C. a	<b>2.32</b>	a
<b>2.18</b>	c		

- 2.1 (a)  $\bar{A}_1 = 5\angle 30^\circ = 5[\cos 30^\circ + j\sin 30^\circ] = 4.33 + j2.5$   
 (b)  $\bar{A}_2 = -3 + j4 = \sqrt{9+16} \angle \tan^{-1} \frac{4}{-3} = 5\angle 126.87^\circ = 5e^{j126.87^\circ}$   
 (c)  $\bar{A}_3 = (4.33 + j2.5) + (-3 + j4) = 1.33 + j6.5 = 6.635\angle 78.44^\circ$   
 (d)  $\bar{A}_4 = (5\angle 30^\circ)(5\angle 126.87^\circ) = 25\angle 156.87^\circ = -22.99 + j9.821$   
 (e)  $\bar{A}_5 = (5\angle 30^\circ)/(5\angle -126.87^\circ) = 1\angle 156.87^\circ = 1e^{j156.87^\circ}$

- 2.2 (a)  $\bar{I} = 400\angle -30^\circ = 346.4 - j200$   
 (b)  $i(t) = 5\sin(\omega t + 15^\circ) = 5\cos(\omega t + 15^\circ - 90^\circ) = 5\cos(\omega t - 75^\circ)$   
 $\bar{I} = (5/\sqrt{2})\angle -75^\circ = 3.536\angle -75^\circ = 0.9151 - j3.415$   
 (c)  $\bar{I} = (4/\sqrt{2})\angle -30^\circ + 5\angle -75^\circ = (2.449 - j1.414) + (1.294 - j4.83)$   
 $= 3.743 - j6.244 = 7.28\angle -59.06^\circ$

- 2.3 (a)  $V_{\max} = 359.3\text{ V}; I_{\max} = 100\text{ A}$   
 (b)  $V = 359.3/\sqrt{2} = 254.1\text{ V}; I = 100/\sqrt{2} = 70.71\text{ A}$   
 (c)  $\bar{V} = 254.1\angle 15^\circ\text{ V}; \bar{I} = 70.71\angle -85^\circ\text{ A}$

- 2.4 (a)  $\bar{I}_1 = 10\angle 0^\circ \frac{-j6}{8 + j6 - j6} = 10 \frac{6\angle -90^\circ}{8} = 7.5\angle -90^\circ\text{ A}$   
 $\bar{I}_2 = \bar{I} - \bar{I}_1 = 10\angle 0^\circ - 7.3\angle -90^\circ = 10 + j7.5 = 12.5\angle 36.87^\circ\text{ A}$   
 $\bar{V} = \bar{I}_2(-j6) = (12.5\angle 36.87^\circ)(6\angle -90^\circ) = 75\angle -53.13^\circ\text{ V}$

(b)

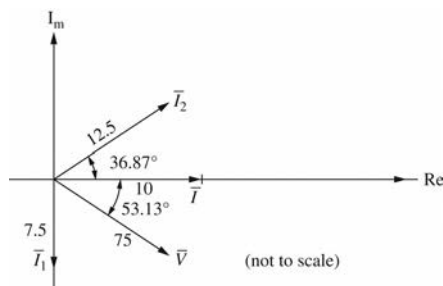

- 2.5 (a)  $v(t) = 277\sqrt{2}\cos(\omega t + 30^\circ) = 391.7\cos(\omega t + 30^\circ)\text{ V}$   
 (b)  $\bar{I} = \bar{V}/20 = 13.85\angle 30^\circ\text{ A}$   
 $i(t) = 19.58\cos(\omega t + 30^\circ)\text{ A}$

$$(c) \quad \bar{Z} = j\omega L = j(2\pi 60)(10 \times 10^{-3}) = 3.771 \angle 90^\circ \Omega$$

$$\bar{I} = \bar{V} / \bar{Z} = (277 \angle 30^\circ) / (3.771 \angle 90^\circ) = 73.46 \angle -60^\circ \text{ A}$$

$$i(t) = 73.46 \sqrt{2} \cos(\omega t - 60^\circ) = 103.9 \cos(\omega t - 60^\circ) \text{ A}$$

$$(d) \quad \bar{Z} = -j25 \Omega$$

$$\bar{I} = \bar{V} / \bar{Z} = (277 \angle 30^\circ) / (25 \angle -90^\circ) = 11.08 \angle 120^\circ \text{ A}$$

$$i(t) = 11.08 \sqrt{2} \cos(\omega t + 120^\circ) = 15.67 \cos(\omega t + 120^\circ) \text{ A}$$

**2.6** (a)  $\bar{V} = (100 / \sqrt{2}) \angle -30^\circ = 70.7 \angle -30^\circ$ ;  $\omega$  does not appear in the answer.

(b)  $v(t) = 100 \sqrt{2} \cos(\omega t + 20^\circ)$ ; with  $\omega = 377$ ,  
 $v(t) = 141.4 \cos(377t + 20^\circ)$

(c)  $\bar{A} = A \angle \alpha$ ;  $\bar{B} = B \angle \beta$ ;  $\bar{C} = \bar{A} + \bar{B}$

$$c(t) = a(t) + b(t) = \sqrt{2} \operatorname{Re}[\bar{C} e^{j\omega t}]$$

The resultant has the same frequency  $\omega$ .

**2.7** (a) The circuit diagram is shown below:

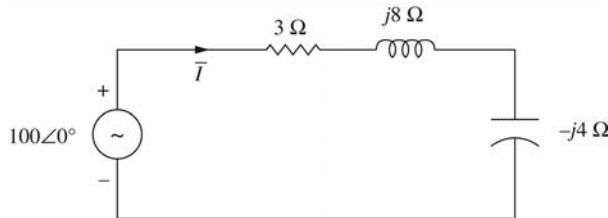

(b)  $\bar{Z} = 3 + j8 - j4 = 3 + j4 = 5 \angle 53.1^\circ \Omega$

(c)  $\bar{I} = (100 \angle 0^\circ) / (5 \angle 53.1^\circ) = 20 \angle -53.1^\circ \text{ A}$

The current lags the source voltage by  $53.1^\circ$

Power Factor =  $\cos 53.1^\circ = 0.6$  Lagging

**2.8**  $\bar{Z}_{LT} = j(377)(30.6 \times 10^{-6}) = j11.536 \text{ m}\Omega$

$$\bar{Z}_{LL} = j(377)(5 \times 10^{-3}) = j1.885 \Omega$$

$$\bar{Z}_C = -j \frac{1}{(377)(921 \times 10^{-6})} = -j2.88 \Omega$$

$$\bar{V} = \frac{120 \sqrt{2}}{\sqrt{2}} \angle -30^\circ \text{ V}$$

The circuit transformed to phasor domain is shown below:

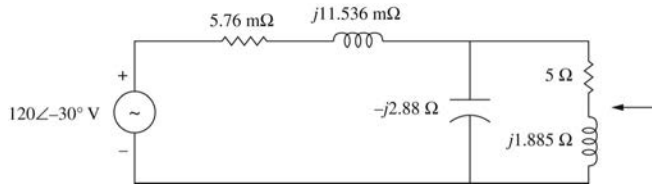

$$\begin{aligned}
 \mathbf{2.9} \quad \text{KVL: } 120\angle 0^\circ &= (60\angle 0^\circ)(0.1 + j0.5) + \bar{V}_{LOAD} \\
 \therefore \bar{V}_{LOAD} &= 120\angle 0^\circ - (60\angle 0^\circ)(0.1 + j0.5) \\
 &= 114.1 - j30.0 = 117.9\angle -14.7^\circ \text{ V} \leftarrow
 \end{aligned}$$

$$\begin{aligned}
 \mathbf{2.10} \quad (\text{a}) \quad p(t) &= v(t)i(t) = [359.3 \cos(\omega t + 15^\circ)][100 \cos(\omega t - 85^\circ)] \\
 &= \frac{1}{2}(359.3)(100)[\cos 100^\circ + \cos(2\omega t - 70^\circ)] \\
 &= -3120 + 1.797 \times 10^4 \cos(2\omega t - 70^\circ) \text{ W}
 \end{aligned}$$

$$\begin{aligned}
 (\text{b}) \quad P &= VI \cos(\delta - \beta) = (254.1)(70.71) \cos(15^\circ + 85^\circ) \\
 &= -3120 \text{ W} \quad \text{Absorbed} \\
 &= +3120 \text{ W} \quad \text{Delivered}
 \end{aligned}$$

$$\begin{aligned}
 (\text{c}) \quad Q &= VI \sin(\delta - \beta) = (254.1)(70.71) \sin 100^\circ \\
 &= 17.69 \text{ kVAR Absorbed}
 \end{aligned}$$

(d) The phasor current  $(-\bar{I}) = 70.71\angle -85^\circ + 180^\circ = 70.71\angle 95^\circ$  A leaves the positive terminal of the generator.

The generator power factor is then  $\cos(15^\circ - 95^\circ) = 0.1736$  leading

$$\begin{aligned}
 \mathbf{2.11} \quad (\text{a}) \quad p(t) &= v(t)i(t) = 391.7 \times 19.58 \cos^2(\omega t + 30^\circ) \\
 &= 0.7669 \times 10^4 \left(\frac{1}{2}\right) [1 + \cos(2\omega t + 60^\circ)] \\
 &= 3.834 \times 10^3 + 3.834 \times 10^3 \cos(2\omega t + 60^\circ) \text{ W} \\
 P &= VI \cos(\delta - \beta) = 277 \times 13.85 \cos 0^\circ = 3.836 \text{ kW} \\
 Q &= VI \sin(\delta - \beta) = 0 \text{ VAR}
 \end{aligned}$$

$$\text{Source Power Factor} = \cos(\delta - \beta) = \cos(30^\circ - 30^\circ) = 1.0$$

$$\begin{aligned}
 (\text{b}) \quad p(t) &= v(t)i(t) = 391.7 \times 103.9 \cos(\omega t + 30^\circ) \cos(\omega t - 60^\circ) \\
 &= 4.07 \times 10^4 \left(\frac{1}{2}\right) [\cos 90^\circ + \cos(2\omega t - 30^\circ)] \\
 &= 2.035 \times 10^4 \cos(2\omega t - 30^\circ) \text{ W} \\
 P &= VI \cos(\delta - \beta) = 277 \times 73.46 \cos(30^\circ + 60^\circ) = 0 \text{ W}
 \end{aligned}$$

$$Q = VI \sin(\delta - \beta) = 277 \times 73.46 \sin 90^\circ = 20.35 \text{ kVAR}$$

$$pf = \cos(\delta - \beta) = 0 \text{ Lagging}$$

$$\begin{aligned} \text{(c) } p(t) &= v(t)i(t) = 391.7 \times 15.67 \cos(\omega t + 30^\circ) \cos(\omega t + 120^\circ) \\ &= 6.138 \times 10^3 \left(\frac{1}{2}\right) [\cos(-90^\circ) + \cos(2\omega t + 150^\circ)] = 3.069 \times 10^3 \cos(2\omega t + 150^\circ) \text{ W} \end{aligned}$$

$$P = VI \cos(\delta - \beta) = 277 \times 11.08 \cos(30^\circ - 120^\circ) = 0 \text{ W}$$

$$Q = VI \sin(\delta - \beta) = 277 \times 11.08 \sin(-90^\circ)$$

$$= -3.069 \text{ kVAR Absorbed} = +3.069 \text{ kVAR Delivered}$$

$$pf = \cos(\delta - \beta) = \cos(-90^\circ) = 0 \text{ Leading}$$

$$\mathbf{2.12} \quad \text{(a) } p_R(t) = (359.3 \cos \omega t)(35.93 \cos \omega t)$$

$$= 6455 + 6455 \cos 2\omega t \text{ W}$$

$$\text{(b) } p_x(t) = (359.3 \cos \omega t)[14.37 \cos(\omega t + 90^\circ)]$$

$$= 2582 \cos(2\omega t + 90^\circ)$$

$$= -2582 \sin 2\omega t \text{ W}$$

$$\text{(c) } P = V^2/R = (359.3/\sqrt{2})^2/10 = 6455 \text{ W Absorbed}$$

$$\text{(d) } Q = V^2/X = (359.3/\sqrt{2})^2/25 = 2582 \text{ VARs Delivered}$$

$$\text{(e) } (\beta - \delta) = \tan^{-1}(Q/P) = \tan^{-1}(2582/6455) = 21.8^\circ$$

$$\text{Power factor} = \cos(\delta - \beta) = \cos(21.8^\circ) = 0.9285 \text{ Leading}$$

$$\mathbf{2.13} \quad \bar{Z} = R - jx_c = 10 - j25 = 26.93 \angle -68.2^\circ \Omega$$

$$i(t) = (359.3/26.93) \cos(\omega t + 68.2^\circ)$$

$$= 13.34 \cos(\omega t + 68.2^\circ) \text{ A}$$

$$\text{(a) } p_R(t) = [13.34 \cos(\omega t + 68.2^\circ)][133.4 \cos(\omega t + 68.2^\circ)]$$

$$= 889.8 + 889.8 \cos[2(\omega t + 68.2^\circ)] \text{ W}$$

$$\text{(b) } p_x(t) = [13.34 \cos(\omega t + 68.2^\circ)][333.5 \cos(\omega t + 68.2^\circ - 90^\circ)]$$

$$= 2224 \sin[2(\omega t + 68.2^\circ)] \text{ W}$$

$$\text{(c) } P = I^2 R = (13.34/\sqrt{2})^2 10 = 889.8 \text{ W}$$

$$\text{(d) } Q = I^2 X = (13.34/\sqrt{2})^2 25 = 2224 \text{ VARs}$$

$$\text{(e) } pf = \cos[\tan^{-1}(Q/P)] = \cos[\tan^{-1}(2224/889.8)]$$

$$= 0.3714 \text{ Leading}$$



2.14 (a)  $\bar{I} = 4\angle 0^\circ \text{ kA}$

$$\bar{V} = \bar{Z}\bar{I} = (2\angle -45^\circ)(4\angle 0^\circ) = 8\angle -45^\circ \text{ kV}$$

$$v(t) = 8\sqrt{2} \cos(\omega t - 45^\circ) \text{ kV}$$

$$\begin{aligned} p(t) &= v(t)i(t) = [8\sqrt{2} \cos(\omega t - 45^\circ)][4\sqrt{2} \cos \omega t] \\ &= 64 \left(\frac{1}{2}\right) [\cos(-45^\circ) + \cos(2\omega t - 45^\circ)] \\ &= 22.63 + 32 \cos(2\omega t - 45^\circ) \text{ MW} \end{aligned}$$

(b)  $P = VI \cos(\delta - \beta) = 8 \times 4 \cos(-45^\circ - 0^\circ) = 22.63 \text{ MW Delivered}$

(c)  $Q = VI \sin(\delta - \beta) = 8 \times 4 \sin(-45^\circ - 0^\circ)$   
 $= -22.63 \text{ MVAR Delivered} = +22.63 \text{ MVAR Absorbed}$

(d)  $pf = \cos(\delta - \beta) = \cos(-45^\circ - 0^\circ) = 0.707 \text{ Leading}$

2.15 (a)  $\bar{I} = [(4/\sqrt{2})\angle 60^\circ] / (2\angle 30^\circ) = \sqrt{2} \angle 30^\circ \text{ A}$

$$i(t) = 2 \cos(\omega t + 30^\circ) \text{ A with } \omega = 377 \text{ rad/s}$$

$$\begin{aligned} p(t) &= v(t)i(t) = 4 [\cos 30^\circ + \cos(2\omega t + 90^\circ)] \\ &= 3.46 + 4 \cos(2\omega t + 90^\circ) \text{ W} \end{aligned}$$

(b)  $v(t)$ ,  $i(t)$ , and  $p(t)$  are plotted below: (See next page)

(c) The instantaneous power has an average value of 3.46 W, and the frequency is twice that of the voltage or current.

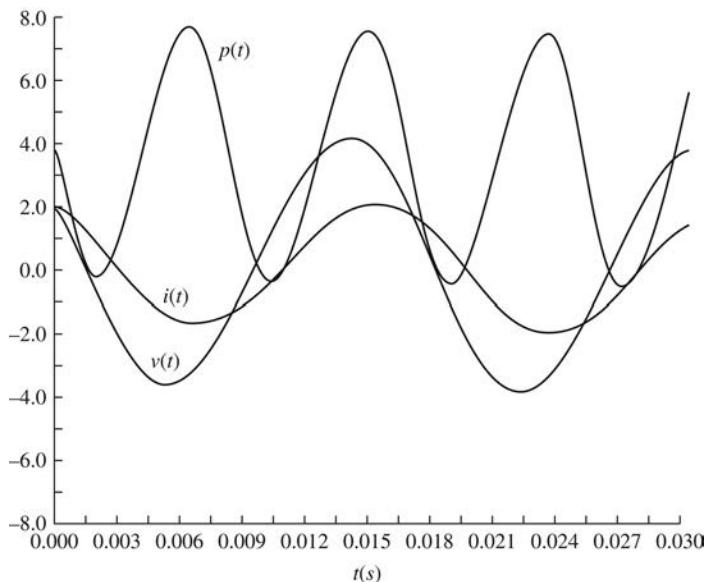

2.16 (a)  $\bar{Z} = 10 + j120\pi \times 0.04 = 10 + j15.1 = 18.1 \angle 56.4^\circ \Omega$

$pf = \cos 56.4^\circ = 0.553$  Lagging

(b)  $\bar{V} = 120 \angle 0^\circ \text{ V}$

The current supplied by the source is

$$\bar{I} = (120 \angle 0^\circ) / (18.1 \angle 56.4^\circ) = 6.63 \angle -56.4^\circ \text{ A}$$

The real power absorbed by the load is given by

$$P = 120 \times 6.63 \times \cos 56.4^\circ = 440 \text{ W}$$

which can be checked by  $I^2 R = (6.63)^2 10 = 440 \text{ W}$

The reactive power absorbed by the load is

$$Q = 120 \times 6.63 \times \sin 36.4^\circ = 663 \text{ VAR}$$

(c) Peak Magnetic Energy =  $W = LI^2 = 0.04 (6.63)^2 = 1.76 \text{ J}$

$$Q = \omega W = 377 \times 1.76 = 663 \text{ VAR is satisfied.}$$

2.17 (a)  $\bar{S} = \bar{V} \bar{I}^* = \bar{Z} \bar{I} \bar{I}^* = \bar{Z} |\bar{I}|^2 = j\omega LI^2$

$$Q = \text{Im}[\bar{S}] = \omega LI^2 \leftarrow$$

(b)  $v(t) = L \frac{di}{dt} = -\sqrt{2} \omega L I \sin(\omega t + \theta)$

$$p(t) = v(t) \cdot i(t) = -2\omega L I^2 \sin(\omega t + \theta) \cos(\omega t + \theta)$$

$$= -\omega L I^2 \sin 2(\omega t + \theta) \leftarrow$$

$$= -Q \sin 2(\omega t + \theta) \leftarrow$$

Average real power  $P$  supplied to the inductor = 0  $\leftarrow$

Instantaneous power supplied (to sustain the changing energy in the magnetic field) has a maximum value of  $Q$ .  $\leftarrow$

2.18 (a)  $\bar{S} = \bar{V} \bar{I}^* = \bar{Z} \bar{I} \bar{I}^* = \text{Re}[\bar{Z} I^2] + j \text{Im}[\bar{Z} I^2]$

$$= P + jQ$$

$$\therefore P = Z I^2 \cos \angle Z; Q = Z I^2 \sin \angle Z \leftarrow$$

(b) Choosing  $i(t) = \sqrt{2} I \cos \omega t$ ,

Then  $v(t) = \sqrt{2} Z I \cos(\omega t + \angle Z)$

$$\therefore p(t) = v(t) \cdot i(t) = Z I^2 \cos(\omega t + \angle Z) \cdot \cos \omega t$$

$$= Z I^2 [\cos \angle Z + \cos(2\omega t + \angle Z)]$$

$$= Z I^2 [\cos \angle Z + \cos 2\omega t \cos \angle Z - \sin 2\omega t \sin \angle Z]$$

$$= P(1 + \cos 2\omega t) - Q \sin 2\omega t \leftarrow$$

$$(c) \bar{Z} = R + j\omega L + \frac{1}{j\omega C}$$

From part (a),  $P = RI^2$  and  $Q = Q_L + Q_C$

$$\text{where } Q_L = \omega LI^2 \text{ and } Q_C = -\frac{1}{\omega C} I^2$$

which are the reactive powers into  $L$  and  $C$ , respectively.

$$\text{Thus } p(t) = P(1 + \cos 2\omega t) - Q_L \sin 2\omega t - Q_C \sin 2\omega t \leftarrow$$

$$\left. \begin{array}{l} \text{If } \omega^2 LC = 1, \quad Q_L + Q_C = Q = 0 \\ \text{Then } \quad p(t) = P(1 + \cos 2\omega t) \end{array} \right\} \leftarrow$$

$$\begin{aligned} 2.19 \quad (a) \quad \bar{S} &= \bar{V} \bar{I}^* = \left( \frac{150}{\sqrt{2}} \angle 10^\circ \right) \left( \frac{5}{\sqrt{2}} \angle -50^\circ \right)^* = 375 \angle 60^\circ \\ &= 187.5 + j324.8 \end{aligned}$$

$$P = \text{Re} \bar{S} = 187.5 \text{ W Absorbed}$$

$$Q = \text{Im} \bar{S} = 324.8 \text{ VARs Absorbed}$$

$$(b) \quad pf = \cos(60^\circ) = 0.5 \text{ Lagging}$$

$$(c) \quad Q_S = P \tan \theta = 187.5 \tan[\cos^{-1} 0.5] = 324.8 \text{ VARs}$$

$$Q_C = Q_L - Q_S = 324.8 - 324.8 = 0 \text{ VARs}$$

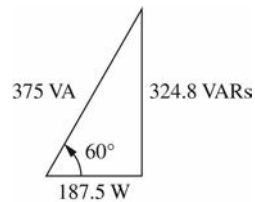

$$2.20 \quad \bar{Y}_1 = \frac{1}{\bar{Z}_1} = \frac{1}{20 \angle 30^\circ} = 0.05 \angle -30^\circ = (0.0433 - j0.025) \text{ S} = G_1 - jB_1$$

$$\bar{Y}_2 = \frac{1}{\bar{Z}_2} = \frac{1}{25 \angle 60^\circ} = 0.04 \angle -60^\circ = (0.02 - j0.03464) \text{ S} = G_2 + jB_2$$

$$P_1 = V^2 G_1 = (100)^2 0.0433 = 433 \text{ W Absorbed}$$

$$Q_1 = V^2 B_1 = (100)^2 0.025 = 250 \text{ VARs Absorbed}$$

$$P_2 = V^2 G_2 = (100)^2 0.02 = 200 \text{ W Absorbed}$$

$$Q_2 = V^2 B_2 = (100)^2 0.03464 = 346.4 \text{ VARs Absorbed}$$

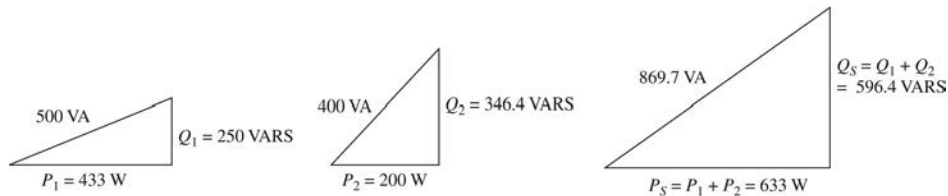

2.21 (a)

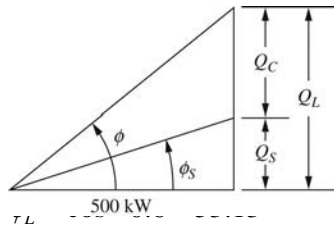

$$Q_L = P \tan \phi_L = 500 \tan 53.13^\circ = 666.7 \text{ kVAR}$$

$$\phi_S = \cos^{-1} 0.9 = 25.84^\circ$$

$$Q_S = P \tan \phi_S = 500 \tan 25.84^\circ = 242.2 \text{ kVAR}$$

$$Q_C = Q_L - Q_S = 666.7 - 242.2 = 424.5 \text{ kVAR}$$

$$S_C = Q_C = 424.5 \text{ kVA}$$

(b) The Synchronous motor absorbs  $P_m = \frac{(500)0.746}{0.9} = 414.4 \text{ kW}$  and  $Q_m = 0 \text{ kVAR}$

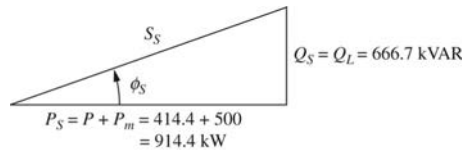

$$\text{Source PF} = \cos \left[ \tan^{-1} (666.7/914.4) \right] = 0.808 \text{ Lagging}$$

$$\begin{aligned} 2.22 \text{ (a)} \quad \bar{Y}_1 &= \frac{1}{\bar{Z}_1} = \frac{1}{(3 + j4)} = \frac{1}{5 \angle 53.13^\circ} = 0.2 \angle -53.13^\circ \\ &= (0.12 - j0.16) \text{ S} \end{aligned}$$

$$\bar{Y}_2 = \frac{1}{\bar{Z}_2} = \frac{1}{10} = 0.1 \text{ S}$$

$$P = V^2 (G_1 + G_2) \Rightarrow V = \sqrt{\frac{P}{G_1 + G_2}} = \sqrt{\frac{1100}{(0.12 + 0.1)}} = 70.71 \text{ V}$$

$$P_1 = V^2 G_1 = (70.71)^2 0.12 = 600 \text{ W}$$

$$P_2 = V^2 G_2 = (70.71)^2 0.1 = 500 \text{ W}$$

$$\begin{aligned} \text{(b)} \quad \bar{Y}_{eq} &= \bar{Y}_1 + \bar{Y}_2 = (0.12 - j0.16) + 0.1 = 0.22 - j0.16 \\ &= 0.272 \angle -36.03^\circ \text{ S} \end{aligned}$$

$$I_S = V Y_{eq} = 70.71(0.272) = 19.23 \text{ A}$$

$$2.23 \quad \bar{S} = \bar{V}\bar{I}^* = (120\angle 0^\circ)(10\angle -30^\circ) = 1200\angle -30^\circ \\ = 1039.2 - j600$$

$$P = \text{Re}\bar{S} = 1039.2 \text{ W Delivered}$$

$$Q = \text{Im}\bar{S} = -600 \text{ VAR S Delivered} = +600 \text{ VAR S Absorbed}$$

$$2.24 \quad \bar{S}_1 = P_1 + jQ_1 = 10 + j0; \bar{S}_2 = 10\angle \cos^{-1} 0.9 = 9 + j4.359$$

$$\bar{S}_3 = \frac{10 \times 0.746}{0.85 \times 0.95} \angle -\cos^{-1} 0.95 = 9.238\angle -18.19^\circ = 8.776 - j2.885$$

$$\bar{S}_S = \bar{S}_1 + \bar{S}_2 + \bar{S}_3 = 27.78 + j1.474 = 27.82\angle 3.04^\circ$$

$$P_S = \text{Re}(\bar{S}_S) = 27.78 \text{ kW}$$

$$Q_S = \text{Im}(\bar{S}_S) = 1.474 \text{ kVAR}$$

$$S_S = |\bar{S}_S| = 27.82 \text{ kVA}$$

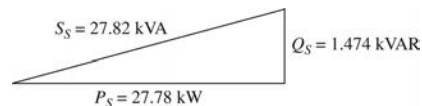

$$2.25 \quad \bar{S}_R = \bar{V}_R\bar{I}^* = R\bar{I}\bar{I}^* = I^2R = (20)^2 3 = 1200 + j0$$

$$\bar{S}_L = \bar{V}_L\bar{I}^* = (jX_L\bar{I})\bar{I}^* = jX_L I^2 = j8(20)^2 = 0 + j3200$$

$$\bar{S}_C = \bar{V}_C\bar{I}^* = (-jX_C\bar{I})\bar{I}^* = -jX_C I^2 = -j4(20)^2 = 0 - j1600$$

$$\text{Complex power absorbed by the total load } \bar{S}_{LOAD} = \bar{S}_R + \bar{S}_L + \bar{S}_C = 2000\angle 53.1^\circ$$

Power Triangle:

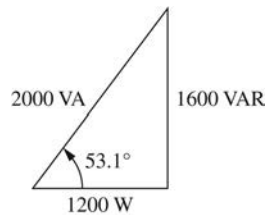

Complex power delivered by the source is

$$\bar{S}_{SOURCE} = \bar{V}\bar{I}^* = (100\angle 0^\circ)(20\angle -53.1^\circ)^* = 2000\angle 53.1^\circ$$

The complex power delivered by the source is equal to the total complex power absorbed by the load.

2.26 (a) The problem is modeled as shown in figure below:

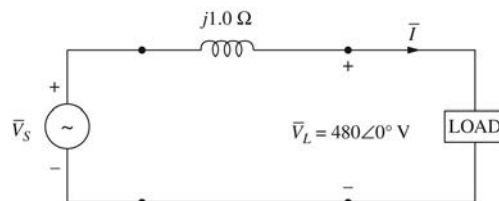

$$P_L = 120 \text{ kW}$$

$$pf_L = 0.85 \text{ Lagging}$$

$$\theta_L = \cos^{-1} 0.85 = 31.79^\circ$$

Power triangle for the load:

$$\begin{aligned}\bar{S}_L &= P_L + jQ_L = 141.18 \angle 31.79^\circ \text{ kVA} \\ I &= S_L / V = 141,180 / 480 = 294.13 \text{ A}\end{aligned}$$

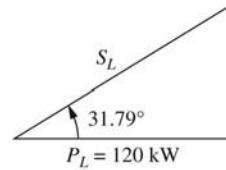

$$\begin{aligned}Q_L &= P_L \tan(31.79^\circ) \\ &= 74.364 \text{ kVAR}\end{aligned}$$

Real power loss in the line is zero.

$$\begin{aligned}\text{Reactive power loss in the line is } Q_{LINE} &= I^2 X_{LINE} = (294.13)^2 1 \\ &= 86.512 \text{ kVAR}\end{aligned}$$

$$\therefore \bar{S}_S = P_S + jQ_S = 120 + j(74.364 + 86.512) = 200.7 \angle 53.28^\circ \text{ kVA}$$

The input voltage is given by  $V_S = S_S / I = 682.4 \text{ V (rms)}$

The power factor at the input is  $\cos 53.28^\circ = 0.6$  Lagging

$$\begin{aligned}\text{(b) Applying KVL, } \bar{V}_S &= 480 \angle 0^\circ + j1.0(294.13 \angle -31.79^\circ) \\ &= 635 + j250 = 682.4 \angle 21.5^\circ \text{ V (rms)} \\ (pf)_S &= \cos(21.5^\circ + 31.79^\circ) = 0.6 \text{ Lagging}\end{aligned}$$

**2.27** The circuit diagram is shown below:

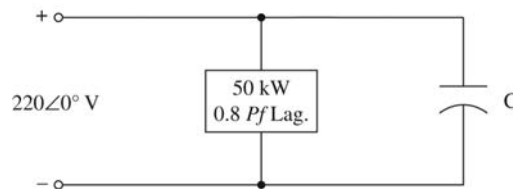

$$\begin{aligned}P_{old} &= 50 \text{ kW}; \cos^{-1} 0.8 = 36.87^\circ; \theta_{OLD} = 36.87^\circ; Q_{old} = P_{old} \tan(\theta_{old}) \\ &= 37.5 \text{ kVAR}\end{aligned}$$

$$\therefore \bar{S}_{old} = 50,000 + j37,500$$

$$\begin{aligned}\theta_{new} &= \cos^{-1} 0.95 = 18.19^\circ; \bar{S}_{new} = 50,000 + j50,000 \tan(18.19^\circ) \\ &= 50,000 + j16,430\end{aligned}$$

$$\text{Hence } \bar{S}_{cap} = \bar{S}_{new} - \bar{S}_{old} = -j21,070 \text{ VA}$$

$$\therefore C = \frac{21,070}{(377)(220)^2} = 1155 \mu\text{F} \leftarrow$$

$$2.28 \quad \bar{S}_1 = 12 + j6.667$$

$$\bar{S}_2 = 4(0.96) - j4[\sin(\cos^{-1} 0.96)] = 3.84 - j1.12$$

$$\bar{S}_3 = 15 + j0$$

$$\bar{S}_{TOTAL} = \bar{S}_1 + \bar{S}_2 + \bar{S}_3 = (30.84 + j5.547) \text{ kVA}$$

(i) Let  $\bar{Z}$  be the impedance of a series combination of  $R$  and  $X$

$$\text{Since } \bar{S} = \bar{V}\bar{I}^* = \bar{V}\left(\frac{\bar{V}}{\bar{Z}}\right)^* = \frac{V^2}{\bar{Z}^*}, \text{ it follows that}$$

$$\bar{Z}^* = \frac{V^2}{\bar{S}} = \frac{(240)^2}{(30.84 + j5.547)10^3} = (1.809 - j0.3254) \Omega$$

$$\therefore \bar{Z} = (1.809 + j0.3254) \Omega \leftarrow$$

(ii) Let  $\bar{Z}$  be the impedance of a parallel combination of  $R$  and  $X$

$$\text{Then } R = \frac{(240)^2}{(30.84)10^3} = 1.8677 \Omega$$

$$X = \frac{(240)^2}{(5.547)10^3} = 10.3838 \Omega$$

$$\therefore \bar{Z} = (1.8677 \parallel j10.3838) \Omega \leftarrow$$

2.29 Since complex powers satisfy KCL at each bus, it follows that

$$\bar{S}_{13} = (1 + j1) - (1 - j1) - (0.4 + j0.2) = -0.4 + j1.8 \leftarrow$$

$$\bar{S}_{31} = -\bar{S}_{13}^* = 0.4 + j1.8 \leftarrow$$

$$\text{Similarly, } \bar{S}_{23} = (0.5 + j0.5) - (1 + j1) - (-0.4 + j0.2) = -0.1 - j0.7 \leftarrow$$

$$\bar{S}_{32} = -\bar{S}_{23}^* = 0.1 - j0.7 \leftarrow$$

$$\text{At Bus 3, } \bar{S}_{G3} = \bar{S}_{31} + \bar{S}_{32} = (0.4 + j1.8) + (0.1 - j0.7) = 0.5 + j1.1 \leftarrow$$

2.30 (a) For load 1:  $\theta_1 = \cos^{-1}(0.28) = 73.74^\circ$  Lagging

$$\bar{S}_1 = 125 \angle 73.74^\circ = 35 + j120$$

$$\bar{S}_2 = 10 - j40$$

$$\bar{S}_3 = 15 + j0$$

$$\bar{S}_{TOTAL} = \bar{S}_1 + \bar{S}_2 + \bar{S}_3 = 60 + j80 = 100 \angle 53.13^\circ \text{ kVA} = P + jQ$$

$$\therefore P_{TOTAL} = 60 \text{ kW}; Q_{TOTAL} = 80 \text{ kVAR}; \text{ kVA}_{TOTAL} = S_{TOTAL} = 100 \text{ kVA.} \leftarrow$$

$$\text{Supply } pf = \cos(53.13^\circ) = 0.6 \text{ Lagging} \leftarrow$$

$$(b) \bar{I}_{TOTAL} = \frac{\bar{S}^*}{\bar{V}^*} = \frac{100 \times 10^3 \angle -53.13^\circ}{1000 \angle 0^\circ} = 100 \angle -53.13^\circ \text{ A}$$

At the new *pf* of 0.8 lagging,  $P_{TOTAL}$  of 60kW results in the new reactive power  $Q'$ , such that

$$\theta' = \cos^{-1}(0.8) = 36.87^\circ$$

and  $Q' = 60 \tan(36.87^\circ) = 45 \text{ kVAR}$

$\therefore$  The required capacitor's kVAR is  $Q_c = 80 - 45 = 35 \text{ kVAR} \leftarrow$

It follows then  $X_c = \frac{V^2}{\bar{S}_c^*} = \frac{(1000)^2}{j35000} = -j28.57 \Omega$

and  $C = \frac{10^6}{2\pi(60)(28.57)} = 92.85 \mu\text{F} \leftarrow$

The new current is  $I' = \frac{\bar{S}'^*}{\bar{V}^*} = \frac{60,000 - j45,000}{1000 \angle 0^\circ} = 60 - j45 = 75 \angle -36.87^\circ \text{ A}$

The supply current, in magnitude, is reduced from 100A to 75A  $\leftarrow$

**2.31** (a)  $\bar{I}_{12} = \frac{V_1 \angle \delta_1 - V_2 \angle \delta_2}{X \angle 90^\circ} = \left( \frac{V_1}{X} \angle \delta_1 - 90^\circ \right) - \frac{V_2}{X} \angle \delta_2 - 90^\circ$

Complex power  $\bar{S}_{12} = \bar{V}_1 \bar{I}_{12}^* = V_1 \angle \delta_1 \left[ \frac{V_1}{X} \angle 90^\circ - \delta_1 - \frac{V_2}{X} \angle 90^\circ - \delta_2 \right]$

$$= \frac{V_1^2}{X} \angle 90^\circ - \frac{V_1 V_2}{X} \angle 90^\circ + \delta_1 - \delta_2$$

$\therefore$  The real and reactive power at the sending end are

$$P_{12} = \frac{V_1^2}{X} \cos 90^\circ - \frac{V_1 V_2}{X} \cos(90^\circ + \delta_1 - \delta_2)$$

$$= \frac{V_1 V_2}{X} \sin(\delta_1 - \delta_2) \leftarrow$$

$$Q_{12} = \frac{V_1^2}{X} \sin 90^\circ - \frac{V_1 V_2}{X} \sin(90^\circ + \delta_1 - \delta_2)$$

$$= \frac{V_1}{X} [V_1 - V_2 \cos(\delta_1 - \delta_2)] \leftarrow$$

Note: If  $\bar{V}_1$  leads  $\bar{V}_2$ ,  $\delta = \delta_1 - \delta_2$  is positive and the real power flows from node 1 to node 2. If  $\bar{V}_1$  Lags  $\bar{V}_2$ ,  $\delta$  is negative and power flows from node 2 to node 1.

(b) Maximum power transfer occurs when  $\delta = 90^\circ = \delta_1 - \delta_2 \leftarrow$

$$P_{MAX} = \frac{V_1 V_2}{X} \leftarrow$$

**2.32** 4 Mvar minimizes the real power line losses, while 4.5 Mvar minimizes the MVA power flow into the feeder.



2.33

Qcap	MW Losses	Mvar Losses
0	0.42	0.84
0.5	0.4	0.8
1	0.383	0.766
1.5	0.369	0.738
2	0.357	0.714
2.5	0.348	0.696
3	0.341	0.682
3.5	0.337	0.675
4	0.336	0.672
4.5	0.337	0.675
5	0.341	0.682
5.5	0.348	0.696
6	0.357	0.714
6.5	0.369	0.738
7	0.383	0.766
7.5	0.4	0.801
8	0.42	0.84
8.5	0.442	0.885
9	0.467	0.934
9.5	0.495	0.99
10	0.525	1.05

2.34 7.5 Mvars

2.35

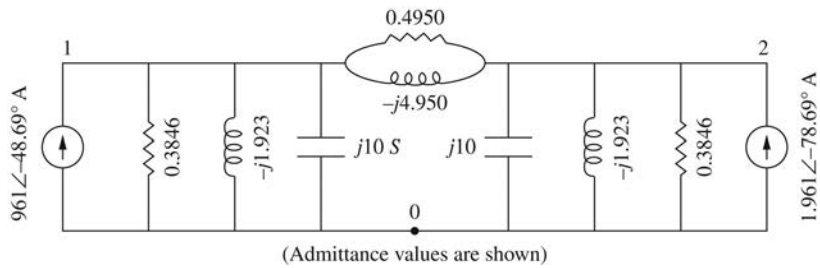

$$\left[ \begin{array}{c|c} (.3846 + .4950) + j(10 - 1.923 - 4.950) & -(.4950 - j4.950) \\ \hline -(.4950 - j4.950) & (.3846 + .4950) + j(10 - 1.923 - 4.95) \end{array} \right] \begin{bmatrix} \bar{V}_{10} \\ \bar{V}_{20} \end{bmatrix} = \begin{bmatrix} 1.961 \angle -48.69^\circ \\ 1.961 \angle -78.69^\circ \end{bmatrix}$$

$$\left[ \begin{array}{c|c} 0.8796 + j3.127 & -0.4950 + j4.950 \\ \hline -0.4950 + j4.950 & -0.8796 + j3.127 \end{array} \right] \begin{bmatrix} \bar{V}_{10} \\ \bar{V}_{20} \end{bmatrix} = \begin{bmatrix} 1.961 \angle -48.69^\circ \\ 1.961 \angle -78.69^\circ \end{bmatrix}$$

**2.36** Note that there are two buses plus the reference bus and one line for this problem. After converting the voltage sources in Fig. 2.23 to current sources, the equivalent source impedances are:

$$\begin{aligned} \bar{Z}_{s1} = \bar{Z}_{s2} &= (0.1 + j0.5) // (-j0.1) = \frac{(0.1 + j0.5)(-j0.1)}{0.1 + j0.5 - j0.1} \\ &= \frac{(0.5099 \angle 78.69^\circ)(0.1 \angle -90^\circ)}{0.4123 \angle 75.96^\circ} = 0.1237 \angle -87.27^\circ \\ &= 0.005882 - j0.1235 \Omega \end{aligned}$$

The rest is left as an exercise to the student.

**2.37** After converting impedance values in Figure 2.29 to admittance values, the bus admittance matrix is:

$$\bar{Y}_{bus} = \begin{bmatrix} 1 & -1 & 0 & 0 \\ -1 \left(1 + \frac{1}{2} + \frac{1}{3} + \frac{1}{4} - j1\right) & -\left(\frac{1}{3} - j1\right) & -\left(\frac{1}{4}\right) \\ 0 & -\left(\frac{1}{3} - j1\right) & \left(\frac{1}{3} - j1 + j\frac{1}{4} + j\frac{1}{2}\right) & -\left(j\frac{1}{4}\right) \\ 0 & -\left(\frac{1}{4}\right) & -\left(j\frac{1}{4}\right) & \left(\frac{1}{4} + j\frac{1}{4} - j\frac{1}{3}\right) \end{bmatrix}$$

Writing nodal equations by inspection:

$$\begin{bmatrix} 1 & -1 & 0 & 0 \\ -1(2.083 - j1) & (-0.3333 + j1) & -0.25 & \\ 0(-0.3333 + j1)(0.3333 - j0.25) & -j0.25 & & \\ 0 & (-0.25) & -j0.25 & (0.25 - j0.08333) \end{bmatrix} \begin{bmatrix} \bar{V}_{10} \\ \bar{V}_{20} \\ \bar{V}_{30} \\ \bar{V}_{40} \end{bmatrix} = \begin{bmatrix} 1 \angle 0^\circ \\ 0 \\ 0 \\ 2 \angle 30^\circ \end{bmatrix}$$

2.38 The admittance diagram for the system is shown below:

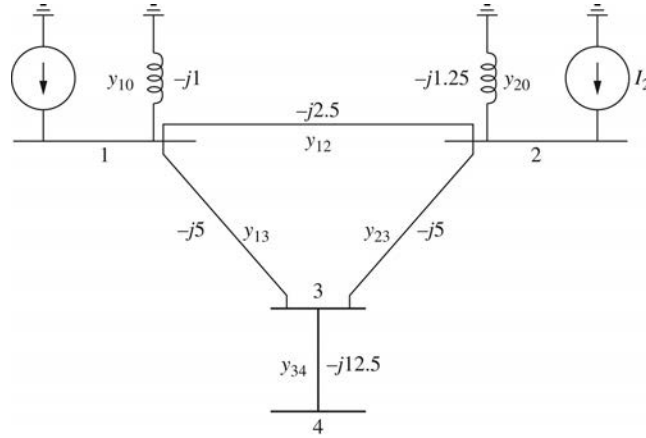

$$\bar{Y}_{BUS} = \begin{bmatrix} \bar{Y}_{11} & \bar{Y}_{12} & \bar{Y}_{13} & \bar{Y}_{14} \\ \bar{Y}_{21} & \bar{Y}_{22} & \bar{Y}_{23} & \bar{Y}_{24} \\ \bar{Y}_{31} & \bar{Y}_{32} & \bar{Y}_{33} & \bar{Y}_{34} \\ \bar{Y}_{41} & \bar{Y}_{42} & \bar{Y}_{43} & \bar{Y}_{44} \end{bmatrix} = j \begin{bmatrix} -8.5 & 2.5 & 5.0 & 0 \\ 2.5 & -8.75 & 5.0 & 0 \\ 5.0 & 5.0 & -22.5 & 12.5 \\ 0 & 0 & 12.5 & -12.5 \end{bmatrix} S$$

where  $\bar{Y}_{11} = \bar{y}_{10} + \bar{y}_{12} + \bar{y}_{13}$ ;  $\bar{Y}_{22} = \bar{y}_{20} + \bar{y}_{12} + \bar{y}_{23}$ ;  $\bar{Y}_{23} = \bar{y}_{13} + \bar{y}_{23} + \bar{y}_{34}$

$\bar{Y}_{44} = y_{34}$ ;  $\bar{Y}_{12} = \bar{Y}_{21} = -\bar{y}_{12}$ ;  $\bar{Y}_{13} = \bar{Y}_{31} = -\bar{y}_{13}$ ;  $\bar{Y}_{23} = \bar{Y}_{32} = -\bar{y}_{23}$

and  $\bar{Y}_{34} = \bar{Y}_{43} = -\bar{y}_{34}$

2.39 (a)

$$\begin{bmatrix} \bar{Y}_c + \bar{Y}_d + \bar{Y}_f & -\bar{Y}_d & -\bar{Y}_c & -\bar{Y}_f \\ -\bar{Y}_d & \bar{Y}_b + \bar{Y}_d + \bar{Y}_e & -\bar{Y}_b & -\bar{Y}_e \\ -\bar{Y}_c & -\bar{Y}_b & \bar{Y}_a + \bar{Y}_b + \bar{Y}_c & 0 \\ -\bar{Y}_f & -\bar{Y}_e & 0 & \bar{Y}_e + \bar{Y}_f + \bar{Y}_g \end{bmatrix} \begin{bmatrix} \bar{V}_1 \\ \bar{V}_2 \\ \bar{V}_3 \\ \bar{V}_4 \end{bmatrix} = \begin{bmatrix} \bar{I}_1 = 0 \\ \bar{I}_2 = 0 \\ \bar{I}_3 \\ \bar{I}_4 \end{bmatrix}$$

$$(b) j \begin{bmatrix} -14.5 & 8 & 4 & 2.5 \\ 8 & -17 & 4 & 5 \\ 4 & 4 & -8.8 & 0 \\ 2.5 & 5 & 0 & -8.3 \end{bmatrix} \begin{bmatrix} \bar{V}_1 \\ \bar{V}_2 \\ \bar{V}_3 \\ \bar{V}_4 \end{bmatrix} = \begin{bmatrix} 0 \\ 0 \\ 1 \angle -90^\circ \\ 0.62 \angle -135^\circ \end{bmatrix}$$

$$\bar{Y}_{BUS} \bar{V} = \bar{I}; \bar{Y}_{BUS}^{-1} \bar{Y}_{BUS} \bar{V} = \bar{Y}_{BUS}^{-1} \bar{I}$$

where  $\bar{Y}_{BUS}^{-1} = \bar{Z}_{BUS} = j \begin{bmatrix} 0.7187 & 0.6688 & 0.6307 & 0.6194 \\ 0.6688 & 0.7045 & 0.6242 & 0.6258 \\ 0.6307 & 0.7045 & 0.6840 & 0.5660 \\ 0.6194 & 0.6258 & 0.5660 & 0.6840 \end{bmatrix} \Omega$

$$\bar{V} = \bar{Y}_{BUS}^{-1} \bar{I}$$

where  $\bar{V} = \begin{bmatrix} \bar{V}_1 \\ \bar{V}_2 \\ \bar{V}_3 \\ \bar{V}_4 \end{bmatrix}$  and  $\bar{I} = \begin{bmatrix} 0 \\ 0 \\ 1 \angle -90^\circ \\ 0.62 \angle -135^\circ \end{bmatrix}$

Then solve for  $\bar{V}_1$ ,  $\bar{V}_2$ ,  $\bar{V}_3$ , and  $\bar{V}_4$ .

**2.40** (a)  $\bar{V}_{AN} = \frac{208}{\sqrt{3}} \angle 0^\circ = 120.1 \angle 0^\circ \text{ V}$  (Assumed as Reference)

$$\bar{V}_{AB} = 208 \angle 30^\circ \text{ V}; \bar{V}_{BC} = 208 \angle -90^\circ \text{ V}; \bar{I}_A = 10 \angle -90^\circ \text{ A}$$

$$\bar{Z}_Y = \frac{\bar{V}_{AN}}{\bar{I}_A} = \frac{120.1 \angle 0^\circ}{10 \angle -90^\circ} = 12.01 \angle -90^\circ = (0 + j12.01) \Omega$$

(b)  $\bar{I}_{AB} = \frac{\bar{I}_A}{\sqrt{3}} \angle 30^\circ = \frac{10}{\sqrt{3}} \angle -90^\circ + 30^\circ = 5.774 \angle -60^\circ \text{ A}$

$$\bar{Z}_\Delta = \frac{\bar{V}_{AB}}{\bar{I}_{AB}} = \frac{208 \angle 30^\circ}{5.774 \angle -60^\circ} = 36.02 \angle 90^\circ = (0 + j36.02) \Omega$$

Note:  $\bar{Z}_Y = \bar{Z}_\Delta / 3$

**2.41**  $\bar{S}_{3\phi} = \sqrt{3} V_{LL} I_L \angle \cos^{-1}(pf)$   
 $= \sqrt{3} (480)(20) \angle \cos^{-1} 0.8$   
 $= 16.627 \times 10^3 \angle 36.87^\circ$   
 $= (13.3 \times 10^3) + j(9.976 \times 10^3)$

$$P_{3\phi} = \text{Re } \bar{S}_{3\phi} = 13.3 \text{ kW} \quad \text{Delivered}$$

$$Q_{3\phi} = \text{Im } \bar{S}_{3\phi} = 9.976 \text{ kVAR} \quad \text{Delivered}$$

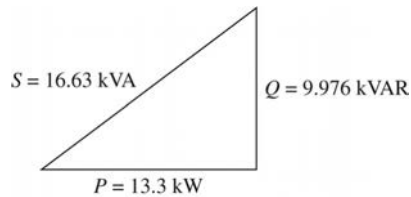

**2.42** (a) With  $\bar{V}_{ab}$  as reference

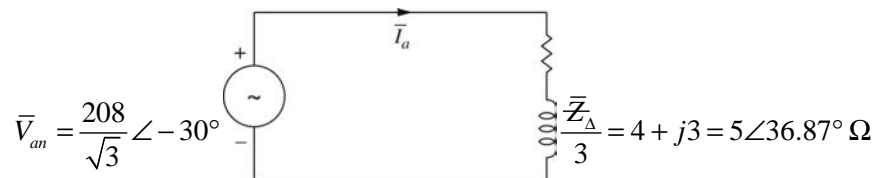

$$\bar{I}_a = \frac{\bar{V}_{an}}{(\bar{Z}_\Delta/3)} = \frac{120.1\angle -30^\circ}{5\angle 36.87^\circ} = 24.02\angle -66.87^\circ \text{ A}$$

$$\begin{aligned}\bar{S}_{3\phi} &= 3\bar{V}_{an}\bar{I}_a^* = 3(120.1\angle -30^\circ)(24.02\angle +66.87^\circ) \\ &= 8654\angle 36.87^\circ = 6923 + j5192\end{aligned}$$

$P_{3\phi} = 6923 \text{ W}; Q_{3\phi} = 5192 \text{ VAR};$  both absorbed by the load

$$pf = \cos(36.87^\circ) = 0.8 \text{ Lagging}; S_{3\phi} = |\bar{S}_{3\phi}| = 8654 \text{ VA}$$

(b)

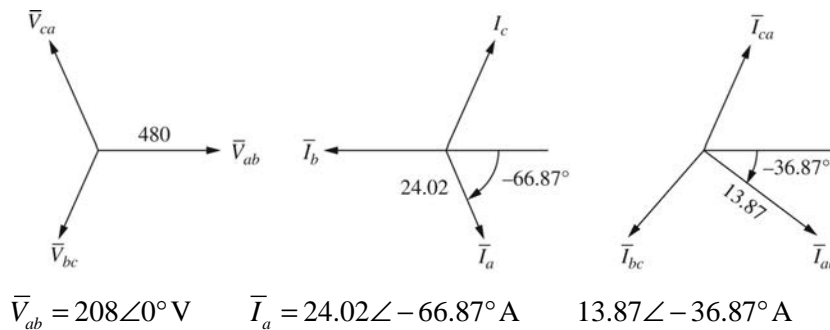

**2.43** (a) Transforming the  $\Delta$ -connected load into an equivalent  $Y$ , the impedance per phase of the equivalent  $Y$  is

$$\bar{Z}_2 = \frac{60 - j45}{3} = (20 - j15) \Omega$$

With the phase voltage  $V_1 = \frac{120\sqrt{3}}{\sqrt{3}} = 120 \text{ V}$  taken as a reference, the per-phase equivalent circuit is shown below:

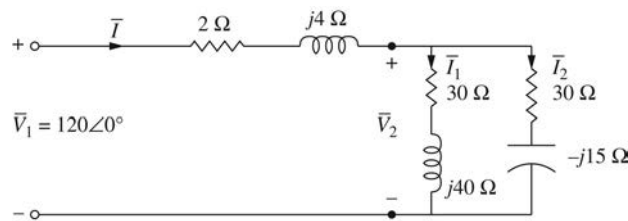

Total impedance viewed from the input terminals is

$$\bar{Z} = 2 + j4 + \frac{(30 + j40)(20 - j15)}{(30 + j40) + (20 - j15)} = 2 + j4 + 22 - j4 = 24 \Omega$$

$$\bar{I} = \frac{\bar{V}_1}{\bar{Z}} = \frac{120\angle 0^\circ}{24} = 5\angle 0^\circ \text{ A}$$

The three-phase complex power supplied =  $\bar{S} = 3\bar{V}_1\bar{I}^* = 1800 \text{ W}$

$P = 1800 \text{ W}$  and  $Q = 0 \text{ VAR}$  delivered by the sending-end source

(b) Phase voltage at load terminals  $\bar{V}_2 = 120\angle 0^\circ - (2 + j4)(5\angle 0^\circ)$   
 $= 110 - j20 = 111.8\angle -10.3^\circ \text{ V}$

The line voltage magnitude at the load terminal is

$$(V_{\text{LOAD}})_{L-L} = \sqrt{3} 111.8 = 193.64 \text{ V}$$

(c) The current per phase in the Y-connected load and in the equiv. Y of the  $\Delta$ -load:

$$\bar{I}_1 = \frac{\bar{V}_2}{\bar{Z}_1} = 1 - j2 = 2.236\angle -63.4^\circ \text{ A}$$

$$\bar{I}_2 = \frac{\bar{V}_2}{\bar{Z}_2} = 4 + j2 = 4.472\angle 26.56^\circ \text{ A}$$

The phase current magnitude in the original  $\Delta$ -connected load

$$(I_{ph})_{\Delta} = \frac{I_2}{\sqrt{3}} = \frac{4.472}{\sqrt{3}} = 2.582 \text{ A}$$

The three-phase complex power absorbed by each load is

$$\bar{S}_1 = 3\bar{V}_2\bar{I}_1^* = 430 \text{ W} + j600 \text{ VAR}$$

$$\bar{S}_2 = 3\bar{V}_2\bar{I}_2^* = 1200 \text{ W} - j900 \text{ VAR}$$

The three-phase complex power absorbed by the line is

$$\bar{S}_L = 3(R_L + jX_L)I^2 = 3(2 + j4)(5)^2 = 150 \text{ W} + j300 \text{ VAR}$$

The sum of load powers and line losses is equal to the power delivered from the supply:

$$\begin{aligned} \bar{S}_1 + \bar{S}_2 + \bar{S}_L &= (430 + j600) + (1200 - j900) + (150 + j300) \\ &= 1800 \text{ W} + j0 \text{ VAR} \end{aligned}$$

**2.44** (a) The per-phase equivalent circuit for the problem is shown below:

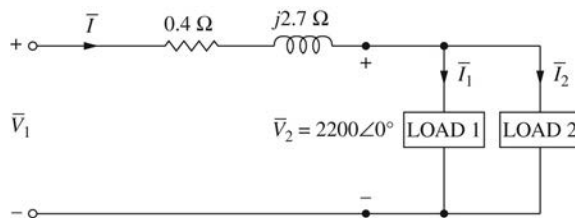

Phase voltage at the load terminals is  $V_2 = \frac{2200\sqrt{3}}{\sqrt{3}} = 2200 \text{ V}$  taken as Ref.

Total complex power at the load end or receiving end is

$$\bar{S}_{R(3\phi)} = 560.1(0.707 + j0.707) + 132 = 528 + j396 = 660\angle 36.87^\circ \text{ kVA}$$

With phase voltage  $\bar{V}_2$  as reference,

$$\bar{I} = \frac{\bar{S}_{R(3\phi)}^*}{3\bar{V}_2^*} = \frac{660,000\angle -36.87^\circ}{3(2200\angle 0^\circ)} = 100\angle -36.87^\circ \text{ A}$$

Phase voltage at sending end is given by

$$\bar{V}_1 = 2200\angle 0^\circ + (0.4 + j2.7)(100\angle -36.87^\circ) = 2401.7\angle 4.58^\circ \text{ V}$$

The magnitude of the line to line voltage at the sending end of the line is

$$(V_1)_{L-L} = \sqrt{3}V_1 = \sqrt{3}(2401.7) = 4160 \text{ V}$$

(b) The three-phase complex-power loss in the line is given by

$$\begin{aligned}\bar{S}_{L(3\phi)} &= 3RI^2 + j3\times I^2 = 3(0.4)(100^2) + j3(2.7)(100)^2 \\ &= 12 \text{ kW} + j81 \text{ kVAR}\end{aligned}$$

(c) The three-phase sending power is

$$\begin{aligned}\bar{S}_{S(3\phi)} &= 3\bar{V}_1\bar{I}^* = 3(2401.7\angle 4.58^\circ)(100\angle 36.87^\circ) \\ &= 540 \text{ kW} + j477 \text{ kVAR}\end{aligned}$$

Note that  $\bar{S}_{S(3\phi)} = \bar{S}_{R(3\phi)} + \bar{S}_{L(3\phi)}$

2.45 (a)

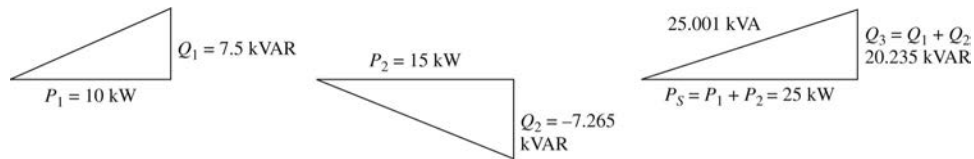

$$I_s = \frac{S_s}{\sqrt{3}V_{LL}} = \frac{25.001 \times 10^3}{\sqrt{3}(480)} = 30.07 \text{ A}$$

(b) The ammeter reads zero, because in a balanced three-phase system, there is no neutral current.

2.46 (a)

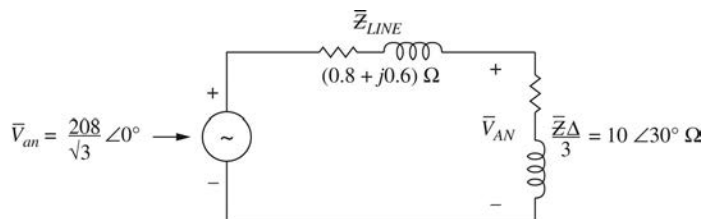

Using voltage division:  $\bar{V}_{AN} = \bar{V}_{an} \frac{\bar{Z}_{\Delta} / 3}{(\bar{Z}_{\Delta} / 3) + \bar{Z}_{LINE}}$

$$= \frac{208}{\sqrt{3}} \angle 0^{\circ} \frac{10 \angle 30^{\circ}}{10 \angle 30^{\circ} + (0.8 + j0.6)}$$

$$= \frac{(120.09)(10 \angle 30^{\circ})}{9.46 + j5.6} = \frac{1200.9 \angle 30^{\circ}}{10.99 \angle 30.62^{\circ}}$$

$$= 109.3 \angle -0.62^{\circ} \text{ V}$$

Load voltage =  $V_{AB} = \sqrt{3} (109.3) = 189.3 \text{ V Line-to-Line}$

(b)

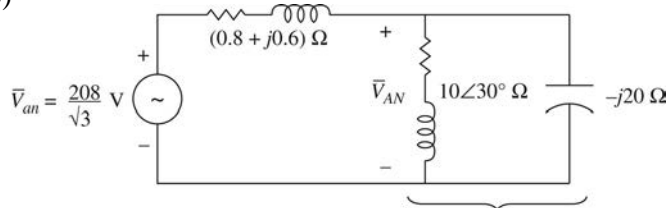

$$\bar{Z}_{eq} = 10 \angle 30^{\circ} \parallel (-j20)$$

$$= 11.547 \angle 0^{\circ} \Omega$$

$$\bar{V}_{AN} = \bar{V}_{an} \frac{\bar{Z}_{eq}}{\bar{Z}_{eq} + \bar{Z}_{LINE}}$$

$$= \left( \frac{208}{\sqrt{3}} \right) \frac{11.547}{(11.547 + 0.8 + j0.6)}$$

$$= \frac{1386.7}{12.362 \angle 2.78^{\circ}} = 112.2 \angle -2.78^{\circ} \text{ V}$$

Load voltage Line-to-Line  $V_{AB} = \sqrt{3} (112.2) = 194.3 \text{ V}$

2.47

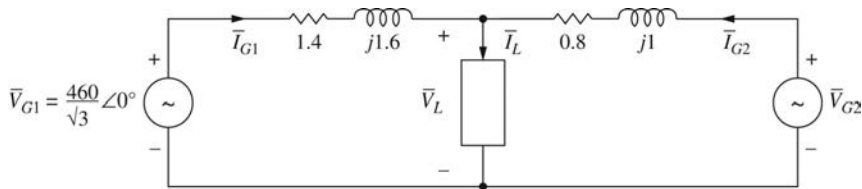

(a)  $\bar{I}_{G1} = \frac{15 \times 10^3}{\sqrt{8} (460)(0.8)} \angle -\cos^{-1} 0.8 = 23.53 \angle -36.87^{\circ} \text{ A}$

$$\bar{V}_L = \bar{V}_{G1} - \bar{Z}_{LINE1} \bar{I}_{G1} = \frac{460}{\sqrt{3}} \angle 0^{\circ} - (1.4 + j1.6)(23.53 \angle -36.87^{\circ})$$

$$= 216.9 \angle -2.73^{\circ} \text{ V Line to Neutral}$$

Load Voltage  $V_L = \sqrt{3} 216.9 = 375.7 \text{ V Line to line}$



$$(b) \bar{I}_L = \frac{30 \times 10^3}{\sqrt{3}(375.7)(0.8)} \angle -2.73^\circ - \cos^{-1} 0.8 = 57.63 \angle -39.6^\circ \text{ A}$$

$$\bar{I}_{G2} = \bar{I}_L - \bar{I}_{G1} = 57.63 \angle -39.6^\circ - 23.53 \angle -36.87^\circ$$

$$= 34.14 \angle -41.49^\circ \text{ A}$$

$$\bar{V}_{G2} = \bar{V}_L + \bar{Z}_{LINE2} \bar{I}_{G2} = 216.9 \angle -2.73^\circ + (0.8 + j1)(34.14 \angle -41.49^\circ)$$

$$= 259.7 \angle -0.63^\circ \text{ V}$$

Generator 2 line-to-line voltage  $V_{G2} = \sqrt{3}(259.7)$   
 $= 449.8 \text{ V}$

$$(c) \bar{S}_{G2} = 3\bar{V}_{G2} \bar{I}_{G2}^* = 3(259.7 \angle -0.63^\circ)(34.14 \angle 41.49^\circ)$$

$$= 20.12 \times 10^3 + j17.4 \times 10^3$$

$P_{G2} = 20.12 \text{ kW}; Q_{G2} = 17.4 \text{ kVAR};$  Both delivered

2.48 (a)

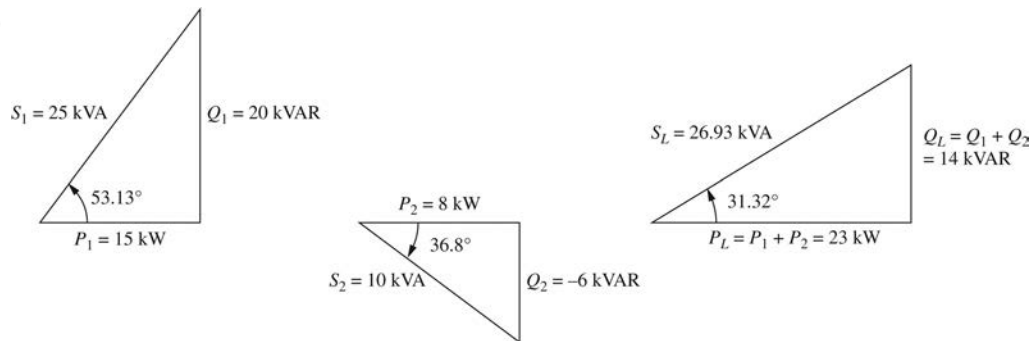

$$(b) pf = \cos 31.32^\circ = 0.854 \text{ Lagging}$$

$$(c) I_L = \frac{S_L}{\sqrt{3}V_{LL}} = \frac{26.93 \times 10^3}{\sqrt{3}(480)} = 32.39 \text{ A}$$

$$(d) Q_C = Q_L = 14 \times 10^3 \text{ VAR} = 3(V_{LL})^2 / X_\Delta$$

$$X_\Delta = \frac{3(480)^2}{14 \times 10^3} = 49.37 \Omega$$

$$(e) I_C = V_{LL} / X_\Delta = 480 / 49.37 = 9.72 \text{ A}$$

$$I_{LINE} = \frac{P_L}{\sqrt{3}V_{LL}} = \frac{23 \times 10^3}{\sqrt{3}480} = 27.66 \text{ A}$$

**2.49** (a) Let  $\bar{Z}_Y = \bar{Z}_A = \bar{Z}_B = \bar{Z}_C$  for a balanced Y-load

$$\bar{Z}_\Delta = \bar{Z}_{AB} = \bar{Z}_{BC} = \bar{Z}_{CA}$$

Using equations in Fig. 2.27

$$\bar{Z}_\Delta = \frac{\bar{Z}_Y^2 + \bar{Z}_Y^2 + \bar{Z}_Y^2}{\bar{Z}_Y} = 3\bar{Z}_Y$$

and

$$\bar{Z}_Y = \frac{\bar{Z}_\Delta^2}{\bar{Z}_\Delta + \bar{Z}_\Delta + \bar{Z}_\Delta} = \frac{\bar{Z}_\Delta}{3}$$

$$(b) \bar{Z}_A = \frac{(j10)(-j25)}{j10 + j20 - j25} = -j50 \Omega$$

$$\bar{Z}_B = \frac{(j10)(j20)}{j5} = j40 \Omega; \bar{Z}_C = \frac{(j20)(-j25)}{j5} = -j100 \Omega$$

**2.50** Replace delta by the equivalent WYE:  $\bar{Z}_Y = -j\frac{2}{3} \Omega$

Per-phase equivalent circuit is shown below:

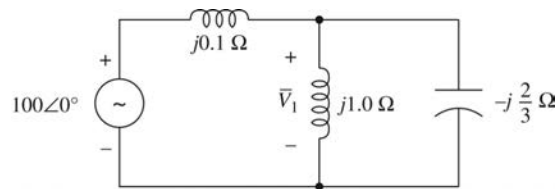

Noting that  $\left( j1.0 \parallel -j\frac{2}{3} \right) = -j2$ , by voltage-divider law,

$$\bar{V}_1 = \frac{-j2}{-j2 + j0.1} (100\angle 0^\circ) = 105\angle 0^\circ$$

$$\therefore v_1(t) = 105\sqrt{2} \cos(\omega t + 0^\circ) = 148.5 \cos \omega t \text{ V} \leftarrow$$

In order to find  $i_2(t)$  in the original circuit, let us calculate  $\bar{V}_{A'B'}$

$$\bar{V}_{A'B'} = \bar{V}_{A'N'} - \bar{V}_{B'N'} = \sqrt{3} e^{j30^\circ} \bar{V}_{A'N'} = 173.2\angle 30^\circ$$

Then 
$$\bar{I}_{A'B'} = \frac{173.2\angle 30^\circ}{-j2} = 86.6\angle 120^\circ$$

$$\begin{aligned} \therefore i_2(t) &= 86.6\sqrt{2} \cos(\omega t + 120^\circ) \\ &= 122.5 \cos(\omega t + 120^\circ) \text{ A} \leftarrow \end{aligned}$$

**2.51** On a per-phase basis  $\bar{S}_1 = \frac{1}{3}(150 + j120) = (50 + j40) \text{ kVA}$

$$\therefore \bar{I}_1 = \frac{(50 - j40)10^3}{2000} = (25 - j20) \text{ A}$$

Note: PF Lagging

Load 2: Convert  $\Delta$  into an equivalent Y

$$\bar{Z}_{2Y} = \frac{1}{3}(150 - j48) = (50 - j16) \Omega$$

$$\therefore \bar{I}_2 = \frac{2000 \angle 0^\circ}{50 - j16} = 38.1 \angle 17.74^\circ$$

$$= (36.29 + j11.61) \text{ A}$$

Note: PF Leading

$$\bar{S}_3 \text{ per phase} = \frac{1}{3}[(120 \times 0.6) - j120 \sin(\cos^{-1} 0.6)] = (24 - j32) \text{ kVA}$$

$$\therefore \bar{I}_3 = \frac{(24 + j32)10^3}{2000} = (12 + j16) \text{ A}$$

Note: PF Leading

Total current drawn by the three parallel loads  $\bar{I}_T = \bar{I}_1 + \bar{I}_2 + \bar{I}_3$

$$\bar{I}_{TOTAL} = (73.29 + j7.61) \text{ A}$$

Note: PF Leading

Voltage at the sending end:  $\bar{V}_{AN} = 2000 \angle 0^\circ + (73.29 + j7.61)(0.2 + j1.0)$

$$= 2007.05 + j74.81 = 2008.44 \angle 2.13^\circ \text{ V}$$

Line-to-line voltage magnitude at the sending end =  $\sqrt{3}(2008.44) = 3478.62 \text{ V} \leftarrow$

**2.52** (a) Let  $\bar{V}_{AN}$  be the reference:  $\bar{V}_{AN} = \frac{2160}{\sqrt{3}} \angle 0^\circ = 2400 \angle 0^\circ \text{ V}$

Total impedance per phase  $\bar{Z} = (4.7 + j9) + (0.3 + j1) = (5 + j10) \Omega$

$$\therefore \text{Line Current} = \frac{2400 \angle 0^\circ}{5 + j10} = 214.7 \angle -63.4^\circ \text{ A} = \bar{I}_A \leftarrow$$

With positive A-B-C phase sequence,

$$\bar{I}_B = 214.7 \angle -183.4^\circ \text{ A}; \bar{I}_C = 214.7 \angle -303.4^\circ = 214.7 \angle 56.6^\circ \text{ A} \leftarrow$$

$$\begin{aligned}
\text{(b) } (\bar{V}_{A'N})_{LOAD} &= 2400\angle 0^\circ - [(214.7\angle -63.4^\circ)(0.3 + j1)] \\
&= 2400\angle 0^\circ - 224.15\angle 9.9^\circ = 2179.2 - j38.54 \\
&= 2179.5\angle -1.01^\circ \text{ V} \leftarrow \\
(\bar{V}_{B'N})_{LOAD} &= 2179.5\angle -121.01^\circ \text{ V}; (\bar{V}_{C'N})_{LOAD} = 2179.5\angle -241.01^\circ \text{ V} \\
\text{(c) } S/\text{Phase} &= (\bar{V}_{A'N})_{LOAD} I_A = (2179.5)(214.7) = 467.94 \text{ kVA} \leftarrow \\
\text{Total apparent power dissipated in all three phases in the load} \\
[S_{3\phi}]_{LOAD} &= 3(467.94) = 1403.82 \text{ kVA} \leftarrow \\
\text{Active power dissipated per phase in load} &= (P_{1\phi})_{LOAD} \\
&= (2179.5)(214.7)\cos(62.39^\circ) = 216.87 \text{ kW} \leftarrow \\
\therefore [P_{3\phi}]_{LOAD} &= 3(216.87) = 650.61 \text{ kW} \leftarrow \\
\text{Reactive power dissipated per phase in load} &= (Q_{1\phi})_{LOAD} \\
&= (2179.5)(214.7)\sin(62.39^\circ) = 414.65 \text{ kVAR} \leftarrow \\
\therefore [Q_{3\phi}]_{LOAD} &= 3(414.65) = 1243.95 \text{ kVAR} \leftarrow \\
\text{(d) Line losses per phase } (P_{1\phi})_{LOSS} &= (214.7)^2 0.3 = 13.83 \text{ kW} \leftarrow \\
\text{Total line loss } (P_{3\phi})_{LOSS} &= 13.83 \times 3 = 41.49 \text{ kW} \leftarrow
\end{aligned}$$



# Chapter 3

## Power Transformers

### ANSWERS TO MULTIPLE-CHOICE TYPE QUESTIONS

<b>3.1</b>	a	<b>3.17</b>	a
<b>3.2</b>	b	<b>3.18</b>	a
<b>3.3</b>	a	<b>3.19</b>	a
<b>3.4</b>	a	<b>3.20</b>	a
<b>3.5</b>	b	<b>3.21</b>	c
<b>3.6</b>	a	<b>3.22</b>	a
<b>3.7</b>	(i) b	<b>3.23</b>	b
	(ii) c	<b>3.24</b>	a
	(iii) a	<b>3.25</b>	c
<b>3.8</b>	a	<b>3.26</b>	b
<b>3.9</b>	(i) b	<b>3.27</b>	a
	(ii) a	<b>3.28</b>	b
<b>3.10</b>	a	<b>3.29</b>	a
<b>3.11</b>	b	<b>3.30</b>	a
<b>3.12</b>	a	<b>3.31</b>	b
<b>3.13</b>	a False	<b>3.32</b>	a
	b True	<b>3.33</b>	a
	c True	<b>3.34</b>	a
<b>3.14</b>	a	<b>3.35</b>	b
<b>3.15</b>	b	<b>3.36</b>	b
<b>3.16</b>	a		

3.1 (a)  $\bar{Z}_1 = a_t^2 = \bar{Z}_2 = \left(\frac{N_1}{N_2}\right)^2 \bar{Z}_2$

(b) Yes

(c) Yes

3.2  $\bar{V}_2 = \frac{N_2}{N_1} \bar{V}_1 = \frac{500}{2000} (1000 \angle 0^\circ) = 250 \angle 0^\circ \text{ V} \leftarrow$

$\bar{I}_2 = \frac{N_1}{N_2} \bar{I}_1 = \frac{2000}{500} (5 \angle -30^\circ) = 20 \angle -30^\circ \text{ A} \leftarrow$

$\bar{Z}_2 = \frac{\bar{V}_2}{\bar{I}_2} = \frac{250 \angle 0^\circ}{20 \angle -30^\circ} = 12.5 \angle 30^\circ \Omega$

$\bar{Z}'_2 = Z_2 \left(\frac{N_1}{N_2}\right)^2 = (12.5 \angle 30^\circ) \left(\frac{2000}{500}\right)^2 = 200 \angle 30^\circ \Omega \leftarrow$

Also  $\bar{Z}'_2 = \bar{V}_1 / \bar{I}_1 = (1000 \angle 0^\circ) / (5 \angle -30^\circ) = 200 \angle 30^\circ \Omega \leftarrow$

3.3

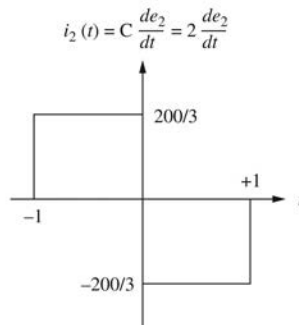
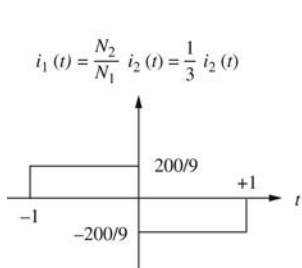
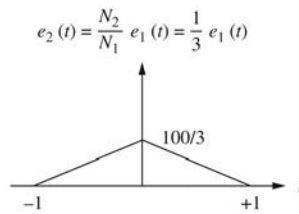
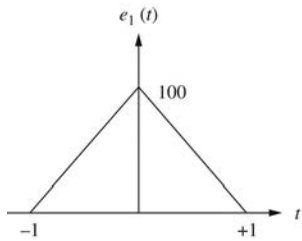
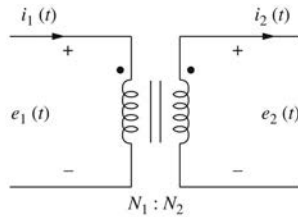

### 3.4

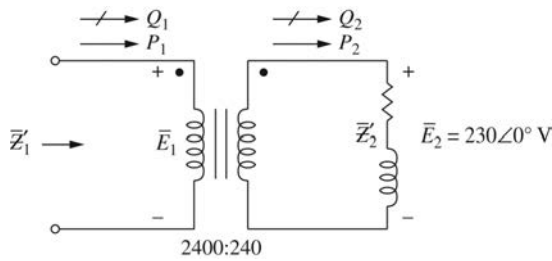

$$(a) \quad E_1 = \frac{N_1}{N_2} E_2 = \frac{2400}{240} (230) = 2300 \text{ V}$$

$$(b) \quad \bar{S}_2 = \bar{E}_2 \bar{I}_2^*; \bar{I}_2 = \left( \frac{\bar{S}_2}{\bar{E}_2} \right)^* = \left[ \frac{80 \times 10^3 \angle \cos^{-1} 0.8}{230 \angle 0^\circ} \right]^* = 347.8 \angle -36.87^\circ$$

$$\bar{Z}_2 = \frac{\bar{E}_2}{\bar{I}_2} = \frac{230 \angle 0^\circ}{347.8 \angle -36.87^\circ} = 0.6613 \angle 36.87^\circ \Omega$$

$$= 0.529 + j0.397 \Omega$$

$$(c) \quad \bar{Z}'_1 = \left( \frac{N_1}{N_2} \right)^2 \bar{Z}_2 = 100 \bar{Z}_2 = 66.13 \angle 36.87^\circ \Omega$$

$$(d) \quad P_1 = P_2 = 80(0.8) = 64 \text{ kW}$$

$$Q_1 = Q_2 = 64 \tan(36.87^\circ) = 48 \text{ kVAR}$$

### 3.5

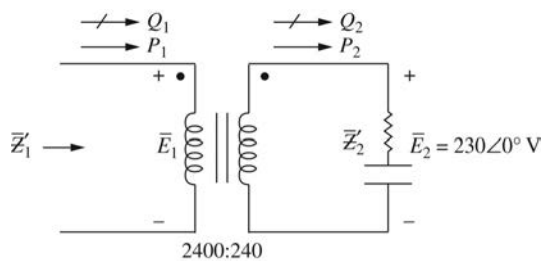

$$(a) \quad E_1 = \frac{N_1}{N_2} E_2 = \left( \frac{2400}{240} \right) (230) = \underline{\underline{2300 \text{ V}}}$$

$$(b) \quad \bar{I}_2 = \left( \frac{\bar{S}_2}{\bar{E}_2} \right)^* = \left[ \frac{110 \times 10^3 \angle -\cos^{-1} 0.85}{230 \angle 0^\circ} \right]^* = 478.26 \angle +31.79^\circ \text{ A}$$

$$\bar{Z}_2 = \frac{\bar{E}_2}{\bar{I}_2} = \frac{230 \angle 0^\circ}{478.26 \angle 31.79^\circ} = 0.4809 \angle -31.79^\circ \Omega$$

$$\bar{Z}_2 = \underline{\underline{0.4088 - j0.2533 \Omega}}$$



$$(c) \quad \bar{Z}_1^1 = \left(\frac{N_1}{N_2}\right)^2 \bar{Z}_2 = 100 \bar{Z}_2 = \underline{\underline{48.09 \angle -31.79^\circ \Omega}}$$

$$(d) \quad P_1 = P_2 = (110)(0.85) = \underline{\underline{93.5 \text{ kW}}}$$

$$Q_1 = Q_2 = 110 \tan(-31.79^\circ) = \underline{\underline{-68.17 \text{ kVAR}}} \text{ supplied to primary winding}$$

### 3.6

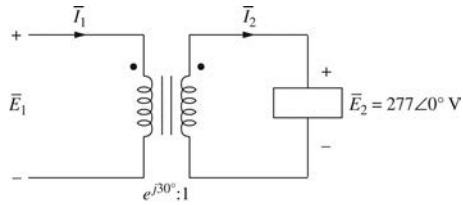

$$(a) \quad \bar{E}_2 = 277 \angle 0^\circ; \quad \bar{E}_1 = \bar{E}_2 e^{j30^\circ} = 277 \angle 30^\circ \text{ V}$$

$$(b) \quad \bar{I}_2 = (S_2 / E_2) \angle \cos^{-1}(PF) = (100 \times 10^3 / 277) \angle \cos^{-1} 0.9 = 361 \angle 25.84^\circ \text{ A}$$

$$\bar{I}_1 = \bar{I}_2 / (e^{j30^\circ})^* = \bar{I}_2 e^{j30^\circ} = 361 \angle 55.84^\circ \text{ A}$$

$$(c) \quad \bar{Z}_2 = \bar{E}_2 / \bar{I}_2 = 277 \angle 0^\circ / 361 \angle 25.84^\circ = 0.7673 \angle -25.84^\circ \Omega$$

$$\bar{Z}_2^1 = \bar{Z}_2 = 0.7673 \angle -25.84^\circ \Omega$$

$$(d) \quad \bar{S}_1 = \bar{S}_2 = 100 \angle -\cos^{-1} 0.9; \quad \text{kVA} = 100 \angle -25.84^\circ$$

$$\bar{S}_1 = 90 \text{ kW} - j43.59 \text{ kVAR} \text{ delivered to primary}$$

### 3.7 (a)

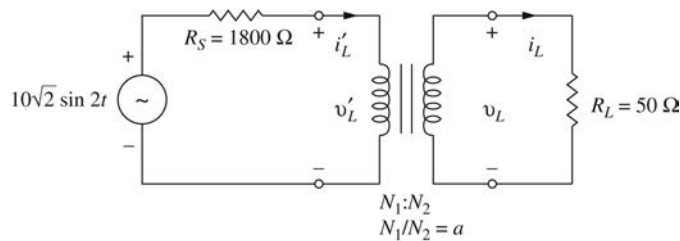

For maximum power transfer to the load,  $R'_L = a^2 R_L = R_S$  or  $50a^2 = 1800$

$$\text{or } a = 6 = N_1 / N_2$$

(b) By voltage division,

$$v'_L = 5\sqrt{2} \sin 2t \text{ V}$$

$$(V'_L)_{RMS} = 5 \text{ V}$$

$$P_{av} = \frac{[(V'_L)_{RMS}]^2}{1800} = \frac{25}{1800} \text{ W} \approx 13.9 \text{ mW}$$

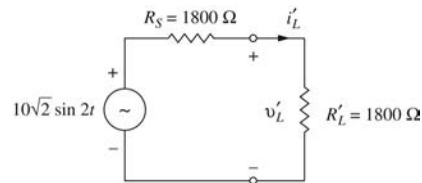

3.8

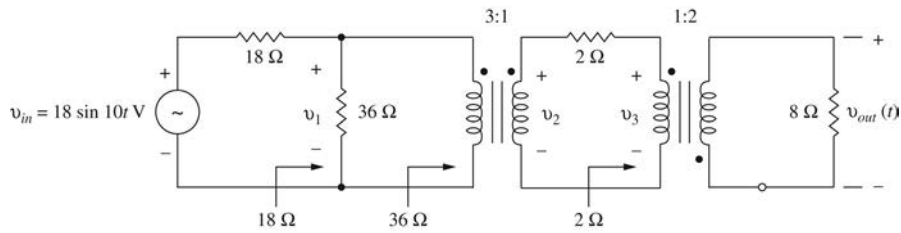

$$v_1 = (18 \sin 10t) / 2 = 9 \sin 10t \text{ V}$$

$$v_2 = \frac{1}{3} v_1 = 3 \sin 10t \text{ V}$$

$$v_3 = \frac{1}{2} v_2 = 1.5 \sin 10t \text{ V}$$

$$v_{out}(t) = -2v_3 = -3 \sin 10t \text{ V}$$

3.9 (a)  $a = N_1 / N_2 = 2000 / 500 = 4$

$$R_{eq1} = 2 + 0.125(4)^2 = 4 \Omega; X_{eq1} = 8 + (0.5)4^2 = 16 \Omega$$

$$\bar{Z}'_2 = 12(4)^2 = 192 \Omega$$

The equivalent circuit referred to primary is shown below:

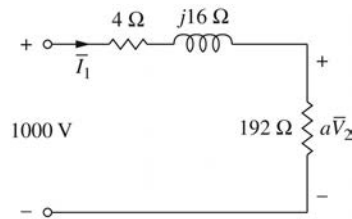

$$\bar{I}_1 = \frac{1000 \angle 0^\circ}{192 + 4 + j16} = 5.08 \angle -4.67^\circ \text{ A}$$

$$a\bar{V}_2 = 192(5.08 \angle -4.67^\circ) = 975.4 \angle -4.67^\circ \text{ V}$$

$$\bar{V}_2 = \frac{975.4 \angle -4.67^\circ}{4} = 243.8 \angle -4.67^\circ \text{ V} \leftarrow$$

(b)  $V_{2,NL} = V_1 / a = 1000 / 4 = 250 \text{ V}$

$$\text{Voltage Regulation} = \frac{250 - 243.8}{243.8} \times 100 = 2.54\% \leftarrow$$

3.10 Rated current magnitude on the 66-kV side is given by

$$I_1 = \frac{15,000}{66} = 227.3 \text{ A}$$

$$I_1^2 R_{eq1} = (227.3)^2 R_{eq1} = 100 \times 10^3$$

$$\therefore R_{eq1} = 1.94 \Omega \leftarrow$$

$$\bar{Z}_{eq1} = \frac{5.5 \times 10^3}{227.3} = 24.2 \Omega$$

$$\text{Then } X_{eq1} = \sqrt{\bar{Z}_{eq1}^2 - R_{eq1}^2} = \sqrt{(24.2)^2 - (1.94)^2} = 24.12 \Omega \leftarrow$$

**3.11** Turns Ratio =  $a = N_1/N_2 = 66/11.5 = 5.74$

With high-voltage side designated as 1, and L-V side as 2,

$$(11.5 \times 10^3)^2 a^2 G_{C1} = 65 \times 10^3, \text{ based on O.C test.}$$

Note: To transfer shunt admittance from H-V side to L-V side, we need to multiply by  $a^2$ .

$$\therefore G_{C1} = \frac{65 \times 10^3}{(11.5 \times 10^3)^2 (5.74)^2} = 14.9 \times 10^{-6} \text{ S} \leftarrow$$

$$Y_1 = \frac{I_2}{V_2} \times \frac{1}{a^2} = \frac{30}{11.5 \times 10^3} \times \frac{1}{(5.74)^2} = 79.2 \times 10^{-6} \text{ S}$$

$$\begin{aligned} \therefore B_{m1} &= \sqrt{Y_1^2 - G_{C1}^2} = 10^{-6} \sqrt{(79.2)^2 - (14.9)^2} \\ &= 77.79 \times 10^{-6} \text{ S} \leftarrow \end{aligned}$$

Total loss under rated conditions is approximately the sum of short-circuit and open-circuit test losses.

$$\therefore \text{Efficiency } \eta_{FL} = \frac{10,000}{(10,000) + (100 + 65)} \times 100 = 98.38\% \leftarrow$$

**3.12** (a)

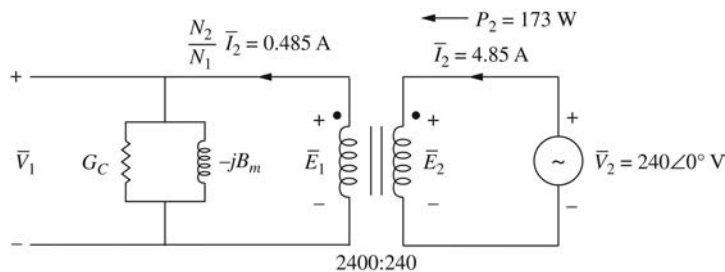

Neglecting series impedance:

$$\bar{E}_1 = \frac{N_1}{N_2} \bar{E}_2 = \frac{N_1}{N_2} \bar{V}_2 = \left( \frac{2400}{240} \right) 240 \angle 0^\circ = 2400 \angle 0^\circ \text{ V}$$

$$\frac{N_2}{N_1} \bar{I}_2 = \frac{240}{2400} (4.85) = 0.485 \text{ A}$$

$$G_C = P_2 / E_1^2 = 173 / (2400)^2 = 3.003 \times 10^{-5} \text{ S}$$

$$Y_C = \left( \frac{N_2}{N_1} I_2 \right) / E_1 = 0.485 / 2400 = 2.021 \times 10^{-4} \text{ S}$$

$$B_m = \sqrt{Y_C^2 - G_C^2} = \sqrt{(2.021 \times 10^{-4})^2 - (3.003 \times 10^{-5})^2} = 1.998 \times 10^{-4} \text{ S}$$

$$\bar{Y}_C = G_C - jB_m = 3.003 \times 10^{-5} - j1.998 \times 10^{-4} \text{ S} = 2.021 \times 10^{-4} \angle -81.45^\circ \text{ S}$$

(b)

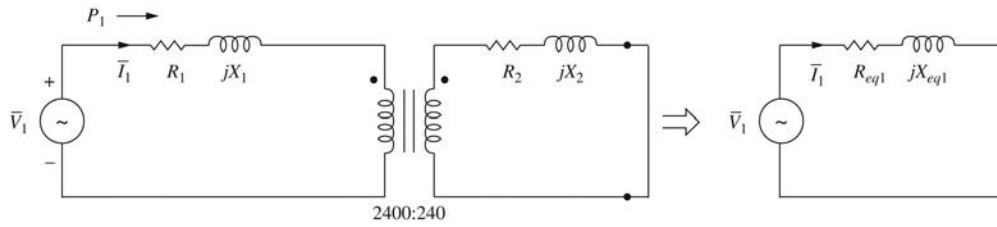

$$R_{eq1} = P_1 / I_1^2 = 650 / (20.8)^2 = 1.502 \Omega$$

$$Z_{eq1} = V_1 / I_1 = 52 / 20.8 = 2.5 \Omega$$

$$X_{eq1} = \sqrt{Z_{eq1}^2 - R_{eq1}^2} = \sqrt{(2.5)^2 - (1.502)^2} = 1.998 \Omega$$

$$\bar{Z}_{eq1} = R_{eq1} + jX_{eq1} = 1.502 + j1.998 = 2.5 \angle 53.07^\circ \Omega$$

(c)

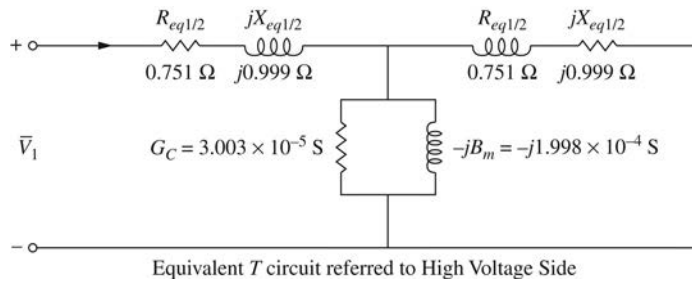

3.13

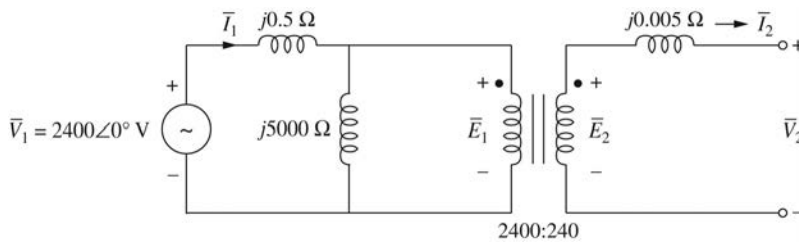

Using voltage division:

$$\bar{E}_1 = (2400 \angle 0^\circ) \frac{j5000}{j(5000 + 0.5)} = 2399.8 \angle 0^\circ \text{ V}$$

$$\bar{V}_2 = \bar{E}_2 = \frac{N_2}{N_1} \bar{E}_1 = 239.98 \angle 0^\circ \text{ V}$$

3.14

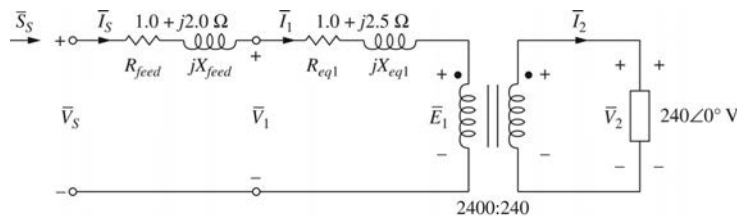

$$(a) \bar{I}_2 = \frac{\text{Seated}}{V_2} \angle -\cos^{-1}(P.F.) = \frac{50 \times 10^3}{240} \angle -\cos^{-1}(0.8) = 208.3 \angle -36.87^\circ \text{ A}$$

$$\bar{I}_1 = \frac{N_2}{N_1} \bar{I}_2 = \frac{1}{10} (208.3 \angle -36.87^\circ) = 20.83 \angle -36.87^\circ \text{ A}$$

$$\bar{E}_1 = \frac{N_1}{N_2} \bar{V}_2 = 10(240 \angle 0^\circ) = 2400 \angle 0^\circ \text{ V}$$

$$\bar{V}_1 = \bar{E}_1 + (R_{eg1} + jX_{eg1}) \bar{I}_1$$

$$\begin{aligned} \bar{V}_1 &= 2400 \angle 0^\circ + (1 + j2.5)(20.83 \angle -36.87^\circ) \\ &= 2400 + 56.095 \angle 31.329^\circ \\ &= 2447.9 + j29.166 = \underline{2448. \angle 0.683^\circ} \text{ V} \end{aligned}$$

$$\begin{aligned} (b) \bar{V}_s &= \bar{E}_1 + (R_{feed} + jX_{feed} + R_{eq1} + jX_{eq1}) \bar{I}_1 \\ &= 2400 \angle 0^\circ + (2.0 + j4.5)(20.83 \angle -36.87^\circ) \\ &= 2400 + 102.59 \angle 29.168^\circ \\ &= 2489.6 + j50.00 = \underline{2490. \angle 1.1505^\circ} \text{ V} \end{aligned}$$

$$\begin{aligned} (c) \bar{S}_s &= \bar{V}_s \bar{I}_s^* = (2490 \angle 1.1505^\circ)(20.83 \angle 36.87^\circ) \\ &= 51875. \angle 38.02^\circ = 40.87 \times 10^3 + j31.95 \times 10^3 \end{aligned}$$

$$\left. \begin{aligned} P_s &= \text{Re}(\bar{S}_s) = 40.87 \text{ kW} \\ Q_s &= I_m(\bar{S}_s) = 31.95 \text{ kVARs} \end{aligned} \right\} \text{delivered to the sending end of feeder.}$$

**3.15** (a)  $\bar{I}_1 = 20.83 \angle 0^\circ$

$$\begin{aligned} \bar{V}_1 &= 2400 \angle 0^\circ + (1 + j2.5)(20.83 \angle 0^\circ) \\ &= 2400 + 56.095 \angle 68.199^\circ = 2420.8 + j52.08 \\ &= 2421. \angle 1.232^\circ \text{ V} \end{aligned}$$

$$\begin{aligned} \bar{V}_s &= 2400 \angle 0^\circ + (2.0 + \sqrt{4.5})(20.83 \angle 0^\circ) \\ &= 2400 + 102.59 \angle 66.04^\circ = 2441.7 + j93.74 \\ &= 2443. \angle 2.199^\circ \text{ V} \end{aligned}$$

$$\begin{aligned} \bar{S}_s &= \bar{V}_s \bar{I}_s^* = (2443 \angle 2.199^\circ)(20.83 \angle 0^\circ) = 50896. \angle 2.199^\circ \\ &= 50,859. + j1953. \end{aligned}$$

$$\left. \begin{aligned} P_s &= 50.87 \text{ kW} \\ Q_s &= 1.953 \text{ kVARs} \end{aligned} \right\} \text{delivered}$$

(b)  $\bar{I}_1 = 20.83 \angle 36.87^\circ \text{ A}$   
 $\bar{V}_1 = 2400 \angle 0^\circ + (1 + j2.5)(20.83 \angle 36.87^\circ)$   
 $= 2400 + 56.095 \angle 105.07^\circ = 2385.4 + j54.17$   
 $= 2386 \angle 1.301^\circ \text{ V}$   
 $\bar{V}_s = 2400 \angle 0^\circ + (2.0 + j4.5)(20.83 \angle 36.87^\circ)$   
 $= 2400 + 102.59 \angle 102.91^\circ = 2377.1 + j100.0$   
 $= 2379. \angle 2.409^\circ \text{ V}$   
 $\bar{S}_s = \bar{V}_s \bar{I}_s^* = (2379. \angle 2.409^\circ)(20.83 \angle -36.87^\circ)$   
 $= 49,566. \angle -34.46^\circ = 40868. - j28047.$   
 $P_s = 40.87 \text{ kW delivered}$   
 $Q_s = -28.05 \text{ kVARs delivered by source to feeder}$   
 $= +28.04 \text{ kVARs absorbed by source}$

Note: Real and reactive losses, 0.87 kW and 1.95 kVARs, absorbed by the feeder and transformer, are the same in all cases. Highest efficiency occurs for unity  $P.F$  ( $EFF = P_{out} / P_s \times 100 = (50 / 50.87) \times 100 = 98.29\%$  ).

**3.16** (a)  $a = 2400 / 240 = 10$

$$R'_2 = a^2 R_2 = \left( \frac{2400}{240} \right)^2 0.0075 = 0.75 \Omega$$

$$X'_2 = a^2 X_2 = (10)^2 0.01 = 1.0 \Omega$$

Referred to the HV-side, the exciting branch conductance and susceptance are given by

$$(1/a^2)0.003 = (1/100)0.003 = 0.03 \times 10^{-3} \text{ S}$$

and  $(1/a^2)0.02 = (1/100)0.02 = 0.2 \times 10^{-3} \text{ S}$

The equivalent circuit referred to the high-voltage side is shown below:

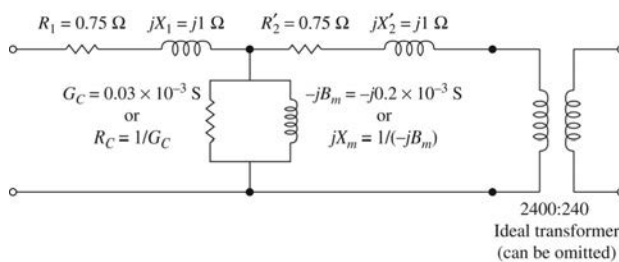

(b)  $R'_1 = R_1 / a^2 = 0.0075 \Omega$   
 $X'_1 = X_1 / a^2 = 0.01 \Omega$

The equivalent circuit referred to the low-voltage side is shown below:

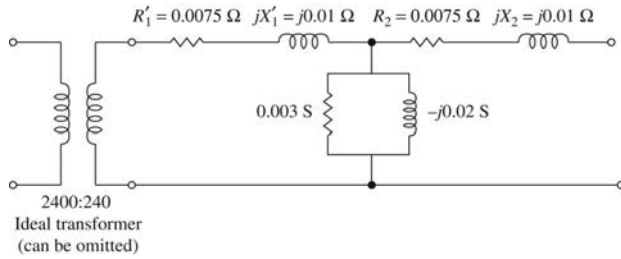

- 3.17 (a) Neglecting the exciting current of the transformer, the equivalent circuit of the transformer, referred to the high-voltage (primary) side is shown below:

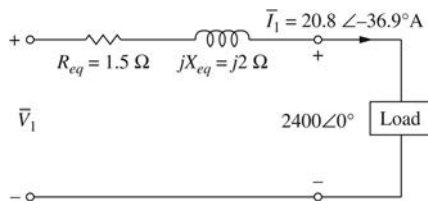

The rated (full) load current, Ref. to HV-side, is given by

$$(50 \times 10^3) / 2400 = 20.8 \text{ A}$$

With a lagging power factor of 0.8,  $\bar{I}_1 = 20.8 \angle -\cos^{-1} 0.8 = 20.8 \angle -36.9^\circ \text{ A}$

Using KVL,  $\bar{V}_1 = 2400 \angle 0^\circ + (20.8 \angle -36.9^\circ)(1.5 + j2) = 2450 \angle 0.34^\circ \text{ V}$

- (b) The corresponding phasor diagram is shown below:

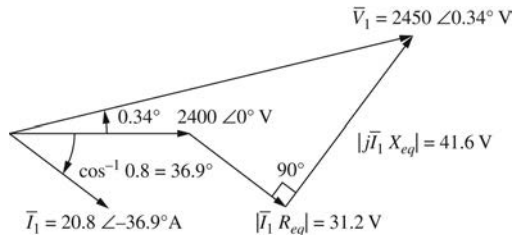

- (c)

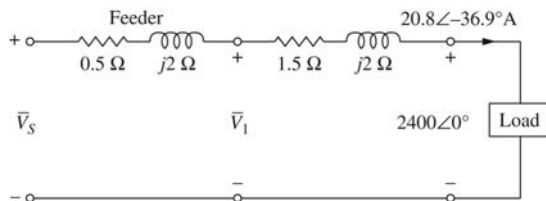

Using KVL,  $\bar{V}_s = 2400 \angle 0^\circ + (20.8 \angle -36.9^\circ)(2 + j4) = 2483.5 \angle 0.96^\circ \text{ V}$  pf at the sending end is  $\cos(36.9^\circ + 0.96^\circ) = 0.79$  Lagging

### 3.18

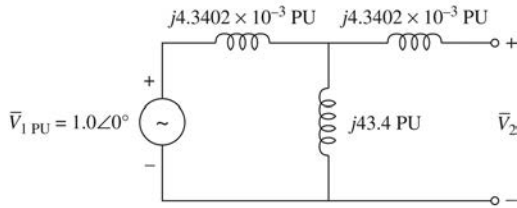

$$S_{Base} = 50 \text{ kVA} \quad V_{Base2} = 240 \text{ V}$$

$$V_{Base1} = 2400 \text{ V}$$

$$Z_{Base1} = (2400)^2 / (50 \times 10^3) = 115.2 \Omega$$

Using voltage division

$$\bar{V}_{2pu} = (1.0 \angle 0^\circ) \frac{j43.4}{j(43.4 + 4.3402 \times 10^{-3})} = 0.9999 \angle 0^\circ \text{ pu}$$

$$\bar{V}_2 = \bar{V}_{2pu} V_{Base2} = (0.9999 \angle 0^\circ)(240) = 239.98 \angle 0^\circ \text{ V}$$

### 3.19

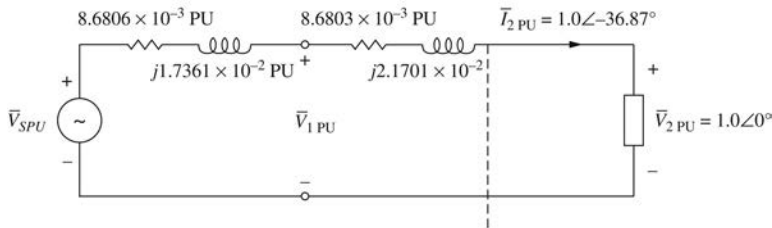

Zone 1

$$S_{base} = 50 \text{ kVA}$$

$$V_{base1} = 2400 \text{ V}$$

$$Z_{base1} = (2400)^2 / 50 \times 10^3 \\ = 115.2 \Omega$$

Zone 2

$$V_{Base2} = 240 \text{ V}$$

$$\begin{aligned} \text{(a) } \bar{V}_{1pu} &= 1.0 \angle 0^\circ + (8.6803 \times 10^{-3} + j2.1701 \times 10^{-2})(1.0 \angle -36.87^\circ) \\ &= 1.0 + 0.023373 \angle 31.33^\circ = 1.01997 + j0.012157 \\ &= 1.020 \angle 0.683^\circ \text{ pu} \end{aligned}$$

$$\bar{V}_1 = \bar{V}_{1pu} V_{base} = (1.020 \angle 0.683^\circ)(2400) = \underline{\underline{2448. \angle 0.683^\circ \text{ V}}}$$

$$\begin{aligned} \text{(b) } \bar{V}_{spu} &= 1.0 \angle 0^\circ + (1.7361 \times 10^{-2} + j3.9063 \times 10^{-2})(1.0 \angle -36.87^\circ) \\ &= 1.0 + 0.042747 \angle 29.168^\circ \\ &= 1.03733 + j0.020833 = 1.037 \angle 1.1505^\circ \text{ pu} \end{aligned}$$

$$\bar{V}_S = \bar{V}_{spu} V_{base1} = (1.0375 \angle 1.1505^\circ)(2400) = \underline{\underline{2490. \angle 1.1505^\circ \text{ V}}}$$



$$(c) \quad P_{spu} + jQ_{spu} = \bar{V}_{spu} \bar{I}_{spu}^* = (1.0375 \angle 1.1505^\circ)(1.0 \angle 36.87^\circ)$$

$$= 1.0375 \angle 38.02^\circ = 0.8173 + j0.6390 \text{ per unit}$$

$$\left. \begin{aligned} P_S &= (0.8173)(50) = 40.87 \text{ kW} \\ Q_S &= (0.6390)(50) = 31.95 \text{ kVARS} \end{aligned} \right\} \text{delivered}$$

### 3.20

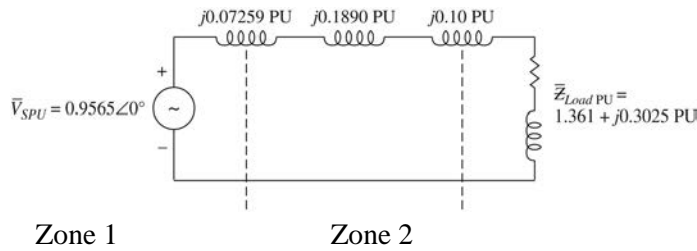

$$V_{base1} = \left( \frac{240}{480} \right) 460 = 230 \text{ V}$$

$$V_{base2} = \left( \frac{460}{115} \right) 115 = 460 \text{ V}$$

$$Z_{base2} = \frac{(460)^2}{20,000} = 10.58 \Omega$$

$$V_{base3} = 115 \text{ V}$$

$$Z_{base3} = \frac{(115)^2}{20,000} = 0.6613 \Omega$$

$$I_{base3} = \frac{20,000}{115} = 173.9 \text{ A}$$

$$\bar{Z}_{Load pu} = \frac{0.9 + j0.2}{0.6613} = 1.361 + j0.3025$$

$$X_{T2 pu} = 0.10 \text{ pu}$$

$$X_{Line pu} = \frac{2}{10.58} = 0.1890 \text{ pu}$$

$$X_{T1 pu} = (0.10) \left( \frac{480}{460} \right)^2 \left( \frac{20}{30} \right) = 0.07259 \text{ pu}$$

$$V_{spu} = \frac{220}{230} = 0.9565 \text{ pu}$$

$$\bar{I}_{Load pu} = \frac{\bar{V}_{spu}}{j(X_{T1 pu} + X_{T2 pu} + X_{Line}) + \bar{Z}_{Load pu}}$$

$$= \frac{0.9565 \angle 0^\circ}{j(.07259 + .1890 + .10) + (1.361 + j.3025)}$$

$$= \frac{0.9565 \angle 0^\circ}{1.361 + j0.6641} = \frac{0.9565 \angle 0^\circ}{1.514 \angle 26.01^\circ}$$

$$= 0.6316 \angle -26.01^\circ \text{ pu}$$

$$\bar{I}_{Load} = \bar{I}_{Load pu} I_{base3} = (0.6316 \angle -26.01^\circ)(173.9)$$

$$= \underline{\underline{109.8 \angle -26.01^\circ \text{ A}}}$$

### 3.21

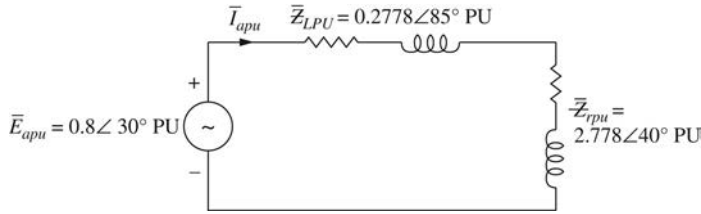

$$\bar{Z}_{base} = \frac{(600)^2}{100 \times 10^3} = 3.6 \, \Omega \quad I_{base} = \frac{100 \times 10^3}{\sqrt{3}(600)} = 96.23 \, \text{A}$$

$$\bar{Z}_{L \, pu} = \frac{1 \angle 85^\circ}{3.6} = 0.2778 \angle 85^\circ \, \text{pu}$$

$$\bar{Z}_{Y \, pu} = \frac{10 \angle 40^\circ}{3.6} = 2.778 \angle 70^\circ \, \text{pu}$$

$$\bar{E}_{a \, pu} = \frac{480/\sqrt{3}}{600/\sqrt{3}} \angle -30^\circ = 0.8 \angle -30^\circ \, \text{pu}$$

$$\bar{I}_{a \, pu} = \frac{\bar{E}_{a \, pu}}{\bar{Z}_{L \, pu} + \bar{Z}_{Y \, pu}} = \frac{0.8 \angle -30^\circ}{0.2778 \angle 85^\circ + 2.778 \angle 40^\circ}$$

$$\bar{I}_{a \, pu} = \frac{0.8 \angle -30^\circ}{2.1521 + j2.0622} = \frac{0.8 \angle -30^\circ}{2.9807 \angle 43.78^\circ}$$

$$\bar{I}_{a \, pu} = 0.2684 \angle -73.78^\circ \, \text{pu}$$

$$\bar{I}_a = \bar{I}_{a \, pu} I_{base} = (0.2684 \angle -73.78^\circ)(96.23)$$

$$\bar{I}_a = 25.83 \angle -73.78^\circ \, \text{A}$$

### 3.22

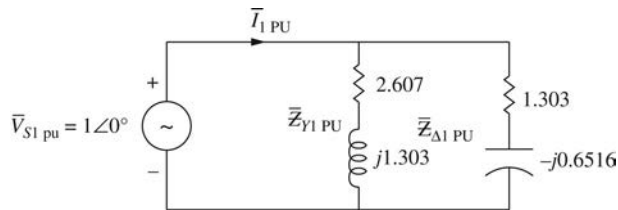

Per-unit positive-sequence circuit

$$\bar{Z}_{base} = (277^2)/1000 = 7.673 \, \Omega$$

$$\bar{Z}_{Y1 \, pu} = (20 + j10)/7.673 = (2.607 + j1.303) \, \text{pu} = 2.914 \angle 26.57^\circ \, \text{pu}$$

$$\bar{Z}_{\Delta 1 \, pu} = (30 - j15)/3(7.673) = (1.303 - j0.6516) \, \text{pu} = 1.437 \angle -26.57^\circ \, \text{pu}$$

$$\begin{aligned}\bar{I}_{1pu} &= \frac{\bar{V}_{S1pu}}{\bar{Z}_{Y1pu} \parallel \bar{Z}_{\Delta 1pu}} = \frac{1.0 \angle 0^\circ}{\left[ \frac{(2.914 \angle 26.57^\circ)(1.457 \angle -26.57^\circ)}{(2.607 + j1.303) + (1.303 - j0.6516)} \right]} \\ &= \frac{1.0 \angle 0^\circ}{\left( \frac{4.246 \angle 0^\circ}{3.91 + j0.6517} \right)} = \frac{1.0 \angle 0^\circ}{1.071 \angle -9.463^\circ} = 0.9337 \angle 9.463^\circ \text{ pu}\end{aligned}$$

$$I_{base} = 1000/277 = 36.1 \text{ A}$$

$$\begin{aligned}\bar{I}_1 &= \bar{I}_{1pu} I_{base} = (0.9337 \angle 9.463^\circ)(36.1) \\ &= 33.71 \angle 9.463^\circ \text{ A}\end{aligned}$$

**3.23** Select a common base of 100MVA and 22kV (not 33kV printed wrongly in the text) on the generator side; Base voltage at bus 1 is 22kV; this fixes the voltage bases for the remaining buses in accordance with the transformer turns ratios. Using Eq. 3.3.11, per-unit reactances on the selected base are given by

$$G : X = 0.18 \left( \frac{100}{90} \right) = 0.2; T_1 : X = 0.1 \left( \frac{100}{50} \right) = 0.2$$

$$T_2 : X = 0.06 \left( \frac{100}{40} \right) = 0.15; T_2 : X = 0.06 \left( \frac{100}{40} \right) = 0.15$$

$$T_3 : X = 0.064 \left( \frac{100}{40} \right) = 0.16; T_4 : X = 0.08 \left( \frac{100}{40} \right) = 0.2$$

$$M : X = 0.185 \left( \frac{100}{66.5} \right) \left( \frac{10.45}{11} \right)^2 = 0.25$$

$$\text{For Line 1, } \bar{Z}_{BASE} = \frac{(220)^2}{100} = 484 \Omega \text{ and } X = \frac{48.4}{484} = 0.1$$

$$\text{For Line 2, } \bar{Z}_{BASE} = \frac{(110)^2}{100} = 121 \Omega \text{ and } X = \frac{65.43}{121} = 0.54$$

The load complex power at 0.6 Lagging *pf* is  $\bar{S}_{L(3\phi)} = 57 \angle 53.13^\circ \text{ MVA}$

$$\begin{aligned}\therefore \text{The load impedance in OHMS is } \bar{Z}_L &= \frac{(10.45)^2}{57 \angle -53.13^\circ} = \frac{V_{LL}^2}{\bar{S}_{L(3\phi)}^*} \\ &= 1.1495 + j1.53267 \Omega\end{aligned}$$

The base impedance for the load is  $(11)^2/100 = 1.21 \Omega$

$$\therefore \text{Load Impedance in pu} = \frac{1.1495 + j1.53267}{1.21} = 0.95 + j1.2667$$

The per-unit equivalent circuit is shown below:

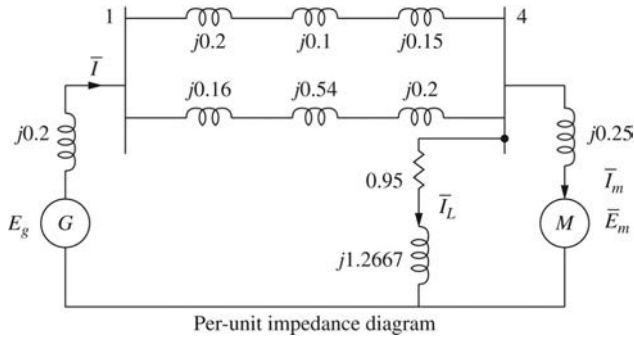

3.24 (a) The per-unit voltage at bus 4, taken as reference, is

$$\bar{V}_4 = \frac{10.45}{11} \angle 0^\circ = 0.95 \angle 0^\circ$$

At 0.8 leading *pf*, the motor apparent power  $\bar{S}_m = \frac{66.5}{100} \angle -36.87^\circ$

$$\begin{aligned} \therefore \text{Current drawn by the motor is } \bar{I}_m &= \frac{\bar{S}_m^*}{\bar{V}_4} = \frac{0.665 \angle 36.87^\circ}{0.95 \angle 0^\circ} \\ &= 0.56 + j0.42 \end{aligned}$$

$$\text{Current drawn by the load is } \bar{I}_L = \frac{\bar{V}_4}{\bar{Z}_L} = \frac{0.95 \angle 0^\circ}{0.95 + j1.2667} = 0.36 - j0.48$$

$$\text{Total current drawn from bus 4 is } \bar{I} = \bar{I}_m + \bar{I}_L = 0.92 - j0.06$$

$$\text{Equivalent reactance of the two lines in parallel is } X_{eq} = \frac{0.45 \times 0.9}{0.45 + 0.9} = 0.3$$

$$\text{Generator terminal voltage is then } \bar{V}_1 = 0.95 \angle 0^\circ + j0.3(0.92 - j0.06)$$

$$\bar{V}_1 = 0.968 + j0.276 = 1.0 \angle 15.91^\circ \text{ pu} = 22 \angle 15.91^\circ \text{ kV}$$

(b) The generator internal EMF is given by

$$\begin{aligned} \bar{E}_g &= \bar{V}_1 + \bar{Z}_g \bar{I} = 0.968 + j0.276 + j0.2(0.92 - j0.06) \\ &= 1.0826 \angle 25.14^\circ \text{ pu} = 23.82 \angle 25.14^\circ \text{ kV} \end{aligned}$$

The motor terminal EMF is given by

$$\begin{aligned} \bar{E}_m &= \bar{V}_4 - \bar{Z}_m \bar{I}_m = 0.95 + j0 - j0.25(0.56 + j0.42) \\ &= 1.064 \angle -7.56^\circ \text{ pu} = 11.71 \angle -7.56^\circ \text{ kV} \end{aligned}$$

3.25

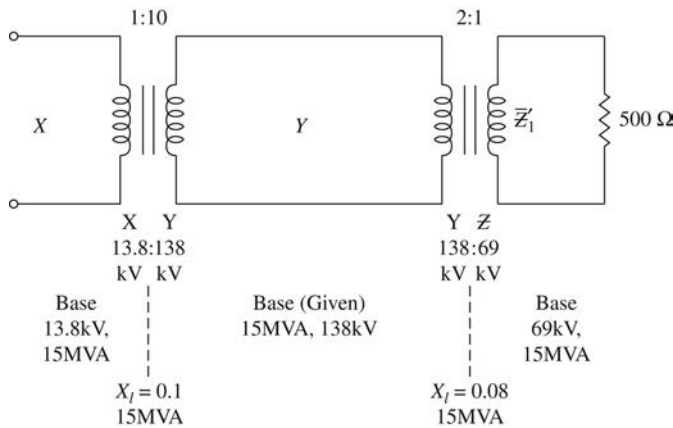

Base impedance in circuit  $Z = \frac{(69 \times 10^3)^2}{15 \times 10^6} = 317.4 \Omega$

Pre-unit impedance of load in circuit  $Z = \frac{500}{317.4} = 1.575$

The impedance diagram in PU is shown below:

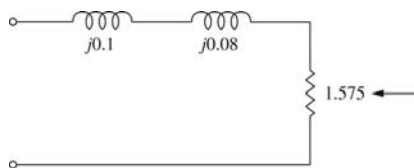

3.26 Base impedance on the low-voltage, 3.81kV-side is

$$\frac{(3.81)^2}{90} = 0.1613 \Omega$$

Note: The rating of the transformer as a 3-phase bank is  $3 \times 30 = 90 \text{ MVA}$ ,  $\sqrt{3}(38.1) : 3.81 = 66 : 3.81 \text{ kV}$

With a base of 66kV on the H-V side, base on L.V side = 3.81 kV so, on L.V. side

$$R_L = \frac{1}{0.1613} = 6.2 \text{ pu}$$

Resistance referred to H.V. side =  $1 \left( \frac{66}{3.81} \right)^2 = 300 \Omega$

Per-unit value should be the same as 6.2 pu.

Check: base impedance on H.V. side =  $\frac{(66)^2}{90} = 48.4 \Omega$  and  $\frac{300}{48.4} = 6.2 \text{ pu}$

**3.27** Transformer reactance on its own base is

$$\frac{0.1}{(22)^2/500} = 0.103 \text{ pu}$$

On the chosen base, reactance becomes

$$0.103 \left( \frac{220}{230} \right)^2 \frac{100}{500} = 0.019 \text{ pu} \leftarrow$$

**3.28** Eq. 3.3.11 of the text applies.

$$G_1 : \bar{Z} = j0.2 \left( \frac{2400}{2400} \right)^2 \left( \frac{100}{10} \right) = j2 \text{ pu}$$

$$G_2 : \bar{Z} = j0.2 \left( \frac{2400}{2400} \right)^2 \left( \frac{100}{20} \right) = j1 \text{ pu}$$

$$T_1 : \bar{Z} = j0.1 \left( \frac{2400}{2400} \right)^2 \left( \frac{100}{40} \right) = j0.25 \text{ pu}$$

$$T_2 : \bar{Z} = j0.1 \left( \frac{10}{9.6} \right)^2 \left( \frac{100}{80} \right) = j0.136 \text{ pu}$$

For the transmission-line zone, base impedance =  $\frac{(9600)^2}{100 \times 10^3}$

$$\therefore \bar{Z}_{LINE} = (50 + j200) \frac{100 \times 10^3}{(9600)^2} = (0.054 + j0.217) \text{ pu}$$

$$M; \text{ kVA} = \frac{25}{100} = 0.25 \text{ pu}; \text{ kV} = \frac{4}{4.8} = 0.833 \text{ pu}$$

The impedance diagram for the system is shown below:

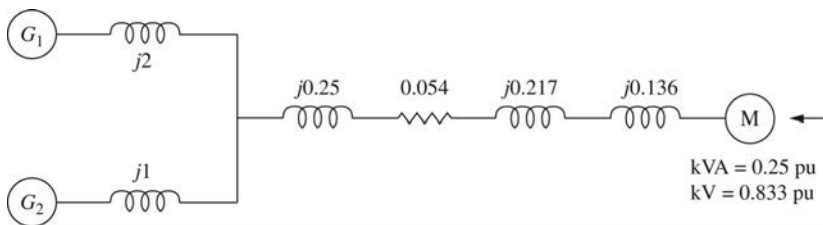

**3.29** Since  $\bar{V}_{a'n'} = n\bar{V}_{ab} = n(\bar{V}_{an} - \bar{V}_{bn})$

$$\left. \begin{aligned} \bar{V}_{a'n'} &= (\sqrt{3}n e^{j30^\circ}) \bar{V}_{an} = \bar{C}_1 \bar{V}_{an} \\ \bar{V}_{b'n'} &= \bar{C}_1 \bar{V}_{bn}; \bar{V}_{c'n'} = \bar{C}_1 \bar{V}_{cn} \end{aligned} \right\} \leftarrow$$

(i) Yes  $\leftarrow$

(ii) Since  $\bar{I}_a = \bar{I}_{ab} - \bar{I}_{ca} = n(\bar{I}'_a - \bar{I}'_c)$

$$\left. \begin{aligned} \bar{I}_a &= (\sqrt{3}n e^{-j30^\circ}) \bar{I}'_a = \bar{C}_1^* \bar{I}'_a; \bar{I}'_a = \bar{I}_a / \bar{C}_1^* \\ \bar{I}'_b &= \bar{I}_b / \bar{C}_1^*; \bar{I}'_c = \bar{I}_c / \bar{C}_1^* \end{aligned} \right\} \leftarrow$$

(iii)  $\bar{S}' = \bar{V}_{a'n'} (\bar{I}'_a)^* = \bar{C}_1 \bar{V}_{an} (\bar{I}_a / \bar{C}_1^*)^* = \bar{V}_{an} \bar{I}_a^* = \bar{S} \leftarrow$

**3.30** For a negative sequence set,

$$\left. \begin{aligned} \bar{V}_{a'n'} &= (\sqrt{3}n e^{-j30^\circ}) \bar{V}_{an} = \bar{C}_1^* \bar{V}_{an} = \bar{C}_2 \bar{V}_{an} \\ \bar{V}_{b'n'} &= \bar{C}_2 \bar{V}_{bn}; \bar{V}_{c'n'} = \bar{C}_2 \bar{V}_{cn} \text{ where } \bar{C}_2 = \bar{C}_1^* \\ \bar{I}_a &= \bar{C}_2^* \bar{I}'_a \text{ or } \bar{I}'_a = \bar{I}_a / \bar{C}_2^* \\ \bar{I}'_b &= \bar{I}_b / \bar{C}_2^*; \bar{I}'_c = \bar{I}_c / \bar{C}_2^* \text{ where } \bar{C}_2 = \bar{C}_1^* \end{aligned} \right\} \leftarrow$$

(i)  $\left. \begin{aligned} \bar{C}_1 &= \sqrt{3}n e^{j30^\circ}; \bar{C}_2 = \sqrt{3}n e^{-j30^\circ} = \bar{C}_1^* \\ \text{Also } \bar{C}_1 &= \bar{C}_2^*; \text{ Note: Taking the complex conjugate} \end{aligned} \right\} \leftarrow$

Transforms a positive sequence set into a negative sequence set.

**3.31**  $\left. \begin{aligned} \bar{V}_{a'n'} &= \left( \frac{n}{\sqrt{3}} e^{j30^\circ} \right) \bar{V}_{an} = \bar{C}_3 \bar{V}_{an} \\ \bar{V}_{b'n'} &= \bar{C}_3 \bar{V}_{bn}; \bar{V}_{c'n'} = \bar{C}_3 \bar{V}_{cn} \end{aligned} \right\} \text{ For the positive seq. set}$

(i)  $\bar{C}_4 = \bar{C}_3^*$  for the negative sequence set

(ii) Complex power gain  $= \bar{C} (1/\bar{C}^*)^* = 1$

(iii)  $\bar{Z}_L = \frac{\bar{V}_{an}}{\bar{I}_a} = \frac{\bar{V}_{a'n'} / \bar{C}}{\bar{C}^* \bar{I}'_a} = \frac{1}{C^2} \bar{Z}_L$ , where  $C = |\bar{C}|$ .

3.32 (a)

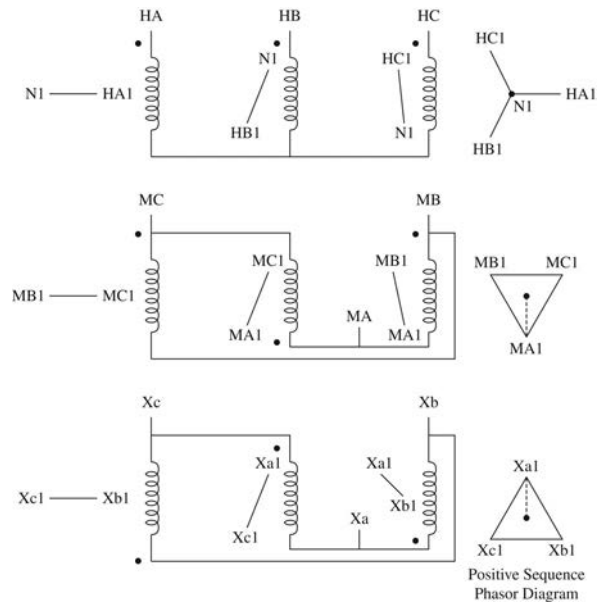

For positive sequence,  $\bar{V}_{H1}$  leads  $\bar{V}_{M1}$  by  $90^\circ$ , and  $\bar{V}_{H1}$  lags  $\bar{V}_{X1}$  by  $90^\circ$ .

For negative sequence,  $\bar{V}_{H2}$  lags  $\bar{V}_{M2}$  by  $90^\circ$ , and  $\bar{V}_{H2}$  leads  $\bar{V}_{X2}$  by  $90^\circ$ .

(b)

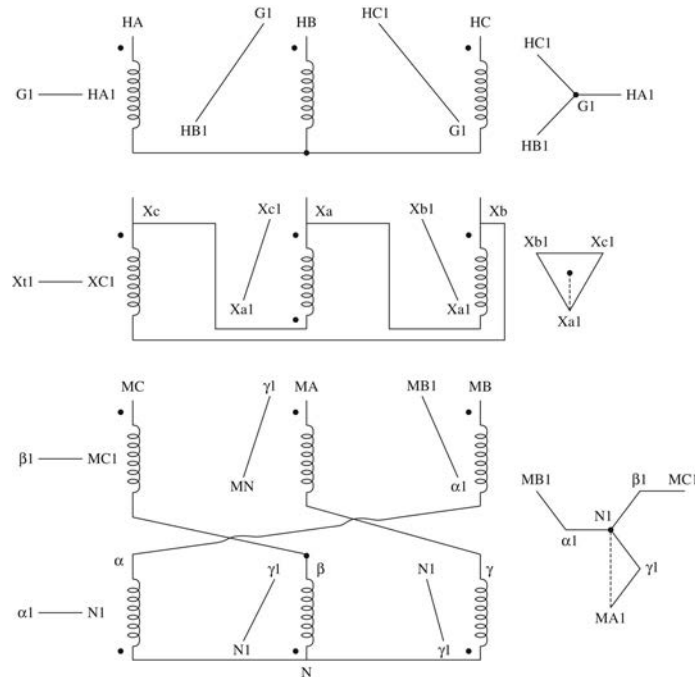

For positive sequence  $\bar{V}_{H1}$  leads  $\bar{V}_{X1}$  by  $90^\circ$  and  $\bar{V}_{X1}$  is in phase with  $\bar{V}_{M1}$ . For

negative sequence  $\bar{V}_{H2}$  lags  $\bar{V}_{X2}$  by  $90^\circ$  and  $\bar{V}_{X2}$  is in phase with  $\bar{V}_{M2}$ . Note that a  $\Delta$ -zig/zag transformer can be used to obtain the advantages of a  $\Delta$ -Y transformer without phase shift.



(c)

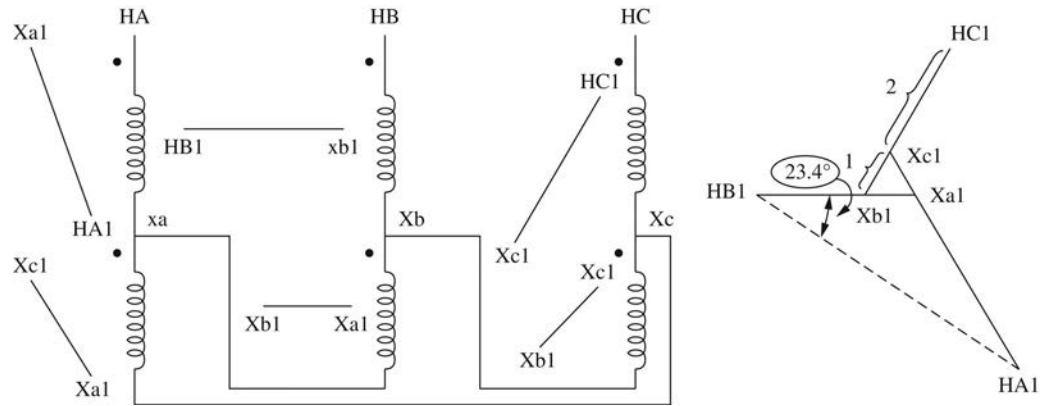

For positive sequence,  $\bar{V}_{H1}$  lags  $\bar{V}_{X1}$  by  $23.4^\circ$ .

For negative sequence,  $\bar{V}_{H2}$  leads  $\bar{V}_{X2}$  by  $23.4^\circ$ .

3.33

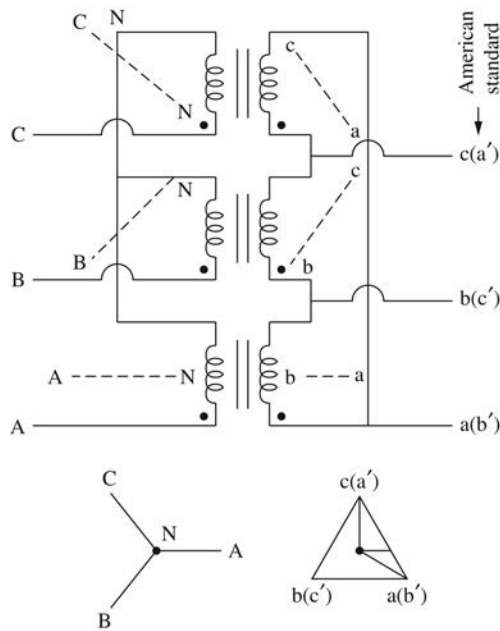

3.34 (a)

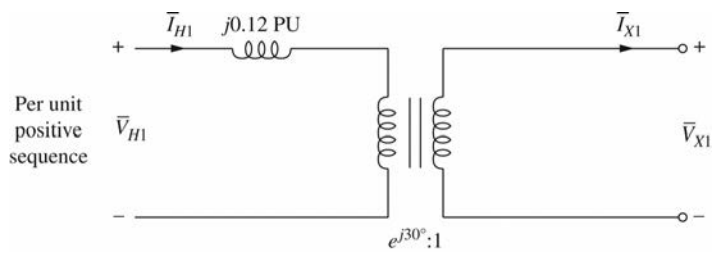

(b)

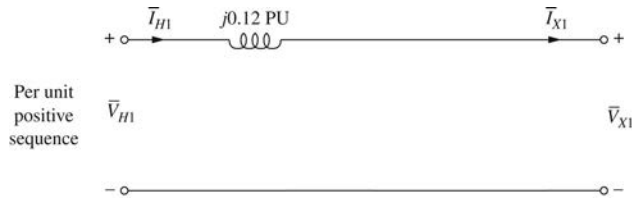

- 3.35 (a) Three-phase rating: 2.1 MVA; 13.8 kV $\Delta$ /2.3 kV $\Delta$   
 Single-phase rating:  $\frac{2.1}{3} = 0.7$  MVA;  $\frac{13.8}{\sqrt{3}} : 2.3 = 7.97 : 2.3$  kV
- (b) Three-phase rating: 2.1 MVA; 13.8 kV $\Delta$ /2.3 kV $\Delta$   
 Single-phase rating: 0.7 MVA;  $13.8 : \frac{2.3}{\sqrt{3}} = 13.8 : 1.33$  kV
- (c) Three-phase rating: 2.1 MVA; 13.8 kV $\Delta$ /2.3 kV $\Delta$   
 Single-phase rating: 0.7 MVA; 7.97 kV : 1.33 kV
- (d) Three-phase rating: 2.1 MVA; 13.8 kV $\Delta$ /2.3 kV $\Delta$   
 Single-phase rating: 0.7 MVA; 13.8 : 2.3 kV

3.36

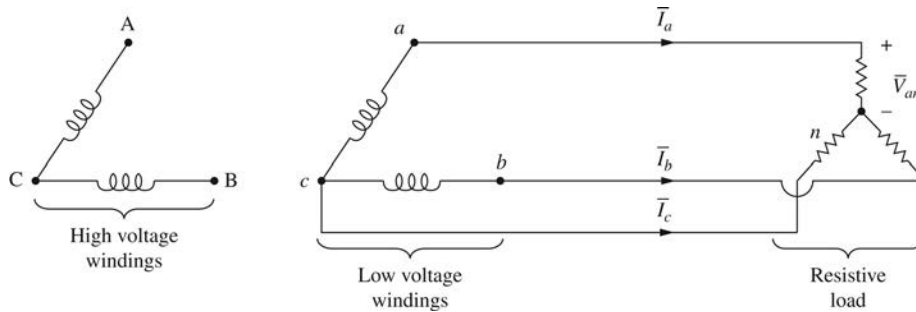

### Open $\Delta$ Transformer

- (a)  $\bar{V}_{bc}$  and  $\bar{V}_{ca}$  remain the same after one, single-phase transformer is removed. Therefore,  $\bar{V}_{ab} = -(\bar{V}_{bc} + \bar{V}_{ca})$  remains the same. The load voltages are then balanced, Positive-sequence. Selecting  $\bar{V}_{an}$  as reference:

$$\bar{V}_{an} = \frac{13.8}{\sqrt{3}} \angle 0^\circ = 7.967 \angle 0^\circ \text{ kV}$$

$$\bar{V}_{bn} = 7.967 \angle -120^\circ \text{ kV}$$

$$\bar{V}_{cn} = 7.967 \angle +120^\circ \text{ kV}$$

$$(b) \bar{I}_a = \frac{S_{3\phi}}{\sqrt{3}V_{LL}} \angle 0^\circ = \frac{43.3 \times 10^6}{\sqrt{3}(13.8 \times 10^3)} = 1.812 \angle 0^\circ \text{ kA}$$

$$\bar{I}_b = 1.812 \angle -120^\circ \text{ kA} \quad \bar{I}_c = 1.812 \angle +120^\circ \text{ kA}$$

$$(c) \bar{V}_{bc} = 13.8 \angle -120^\circ + 30^\circ = 13.8 \angle -90^\circ \text{ kV}$$

$$\text{Transformer bc delivers } \bar{S}_{bc} = \bar{V}_{bc} \bar{I}_b^*$$

$$\bar{S}_{bc} = (13.8 \angle -90^\circ)(1.812 \angle +120^\circ) = \underline{25} \cdot \angle 30^\circ \text{ MVA}$$

$$\bar{S}_{bc} = (21.65 + j12.5) \times 10^6$$

$$\text{Transformer ac delivers } \bar{S}_{ac} = \bar{V}_{ac} \bar{I}_a^*$$

$$\text{where } \bar{V}_{ac} = -\bar{V}_{ca} = -13.8 \angle 120^\circ + 30^\circ = 13.8 \angle -30^\circ \text{ kV}$$

$$\bar{S}_{ac} = (13.8 \angle -30^\circ)(1.812 \angle 0^\circ) = 25 \cdot \angle -30^\circ \text{ MVA}$$

$$\bar{S}_{ac} = (21.65 - j12.5) \times 10^6$$

The open- $\Delta$  transformer is not overloaded. Note that transformer bc delivers 12.5 Mvars and transformer ac absorbs 12.5 Mvars. The total reactive power delivered by the open- $\Delta$  transformer to the resistive load is therefore zero.

**3.37** Noting that  $\sqrt{3}(38.1) = 66$ , the rating of the 3-phase transformer bank is 75 MVA, 66Y/3.81  $\Delta$  kV.

$$\text{Base impedance for the low-voltage side is } \frac{(3.81)^2}{75} = 0.1935 \Omega$$

$$\text{On the low-voltage side, } R_L = \frac{0.6}{0.1935} = 3.1 \text{ pu}$$

$$\text{Base impedance on high-voltage side is } \frac{(66)^2}{75} = 58.1 \Omega$$

$$\text{The resistance ref. to HV-side is } 0.6 \left( \frac{66}{3.81} \right)^2 = 180 \Omega$$

$$\text{or } R_L = \frac{180}{58.1} = 3.1 \text{ pu}$$

- 3.38 (a) The single-line diagram and the per-phase equivalent circuit, with all parameters in per unit, are given below:

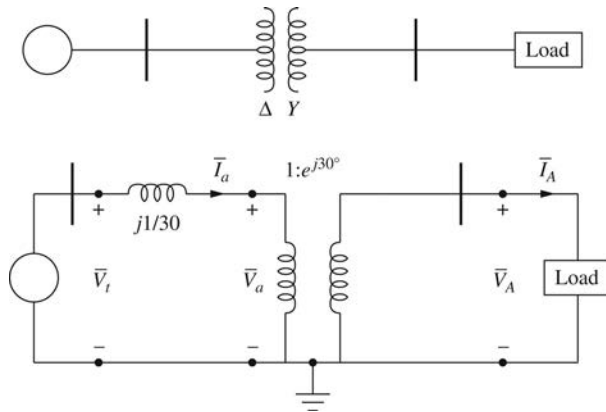

Current supplied to the load is  $\frac{240 \times 10^3}{\sqrt{3} \times 230} = 602.45 \text{ A}$

Base current at the load is  $100,000 / (\sqrt{3} \times 230) = 251.02 \text{ A}$

The power-factor angle of the load current is  $\theta = \cos^{-1} 0.9 = 25.84^\circ \text{ Lag}$ . With  $\bar{V}_A = 1.0 \angle 0^\circ$  as reference, the line currents drawn by the load are

$$\bar{I}_A = \frac{602.45}{251.02} \angle -25.84^\circ = 2.4 \angle -25.84^\circ \text{ per unit}$$

$$\bar{I}_B = 2.4 \angle -25.84^\circ - 120^\circ = 2.4 \angle -145.84^\circ \text{ per unit}$$

$$\bar{I}_C = 2.4 \angle -25.84^\circ + 120^\circ = 2.4 \angle 94.16^\circ \text{ per unit}$$

- (b) Low-voltage side currents further lag by  $30^\circ$  because of phase shift

$$\bar{I}_a = 2.4 \angle -55.84^\circ; \bar{I}_b = 2.4 \angle 175.84^\circ; \bar{I}_c = 2.4 \angle 64.16^\circ$$

- (c) The transformer reactance modified for the chosen base is

$$X = 0.11 \times (100 / 330) = \frac{1}{30} \text{ pu}$$

The terminal voltage of the generator is then given by

$$\begin{aligned} \bar{V}_t &= \bar{V}_A \angle -30^\circ + jX\bar{I}_a \\ &= 1.0 \angle -30^\circ + j(1/30)(2.4 \angle -55.34^\circ) \\ &= 0.9322 - j0.4551 = 1.0374 \angle -26.02^\circ \text{ pu} \end{aligned}$$

Terminal voltage of the generator is  $23 \times 1.0374 = 23.86 \text{ kV}$

The real power supplied by the generator is

$$\text{Re}[\bar{V}_t \bar{I}_a^*] = 1.0374 \times 2.4 \cos(-26.02^\circ + 55.84^\circ) = 2.16 \text{ pu}$$

which corresponds to 216 MW absorbed by the load, since there are no  $I^2R$  losses.

- (d) By omitting the phase shift of the transformer altogether, recalculating  $\bar{V}_t$  with the reactance  $j\left(\frac{1}{30}\right)$  on the high-voltage side, the student will find the same value for  $V_t$  i.e.  $|\bar{V}_t|$ .

### 3.39

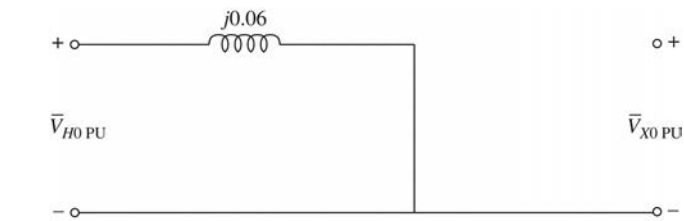

**Zero Sequence**

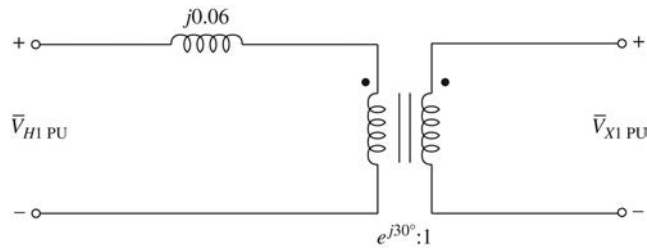

**Positive Sequence**

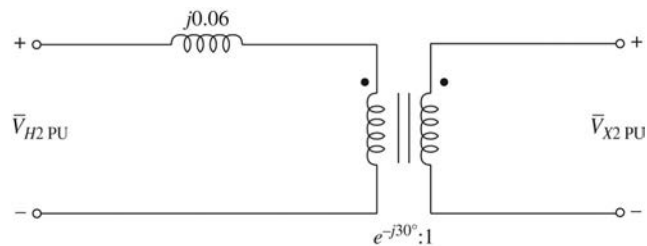

**Negative Sequence**

**3.40**  $X_{pu\ new} = 0.06 \left( \frac{230}{240} \right)^2 \left( \frac{100}{300} \right) = 0.01837\ pu$

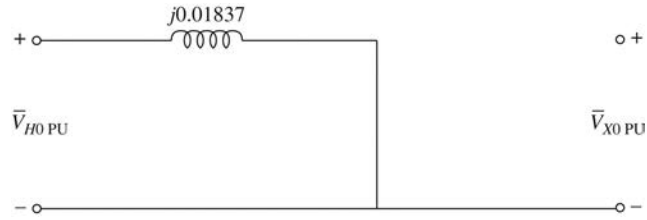

**Zero Sequence**

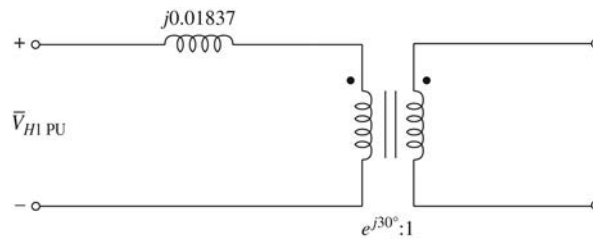

**Positive Sequence**

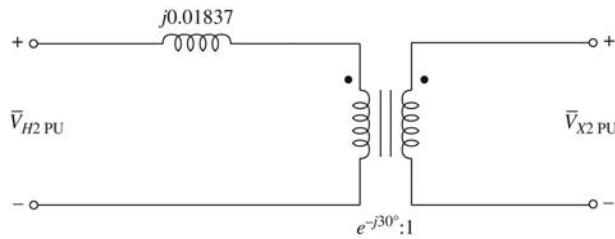

**Negative Sequence**

**3.41**

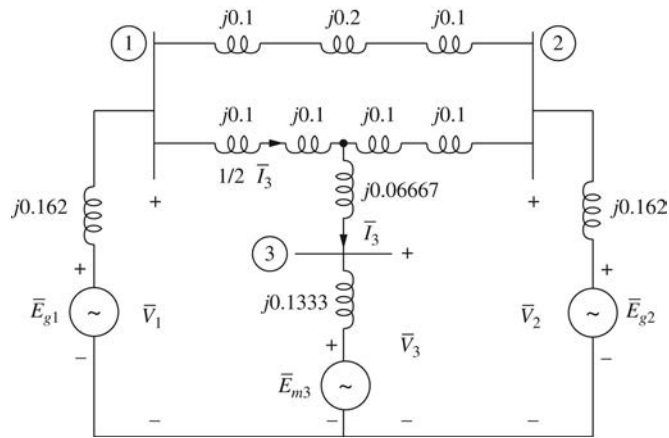

**Per-unit positive-sequence reactance diagram**

$$S_{base} = 100 \text{ MVA}$$

$$V_{base H} = 500 \text{ kV in transmission-line Zones}$$

$$V_{base X} = 20 \text{ kV in motor/generator Zones}$$

$$X''_{g1} = X''_{g2} = 0.2 \left( \frac{18}{20} \right)^2 = 0.162 \text{ pu}$$

$$X''_{m3} = 0.2 \left( \frac{1000}{1500} \right) = 0.1333 \text{ pu}$$

$$X_{T1} = X_{T2} = X_{T3} = X_{T4} = 0.1 \text{ pu}$$

$$X_{TS} = 0.1 \left( \frac{1000}{1500} \right) = 0.06667 \text{ pu}$$

$$Z_{base H} = (500)^2 / 1000 = 250 \Omega$$

$$X_{line 50} = 50 / 250 = 0.2 \text{ pu}$$

$$X_{line 25} = 25 / 250 = 0.1 \text{ pu}$$

$$3.42 \quad \bar{V}_{3pu} = \frac{18}{20} \angle 0^\circ = 0.9 \angle 0^\circ \text{ pu}$$

$$\bar{I}_3 = \frac{1500}{\sqrt{3}(18)(0.8)} \angle \cos^{-1} 0.8 = 60.14 \angle 36.87^\circ \text{ kA}$$

$$I_{base X} = \frac{1000}{20\sqrt{3}} = 28.87 \text{ kA}$$

$$\bar{I}_3 = \frac{60.14}{28.87} \angle 36.87^\circ = 2.083 \angle 36.87^\circ \text{ pu}$$

$$\bar{V}_1 = \bar{V}_2 = \bar{V}_3 + \bar{I}_3 (jX_{T5}) + \frac{1}{2} \bar{I}_3 (jX_{Line25} + jX_{T3})$$

$$= 0.9 \angle 0^\circ + (2.083 \angle 36.87^\circ) \left[ j \left( 0.06667 + \frac{0.1+0.1}{2} \right) \right]$$

$$= 0.7454 \angle 21.88^\circ \text{ pu}$$

$$V_1 = V_2 = 0.7454(20) = 14.91 \text{ kV}$$

3.43

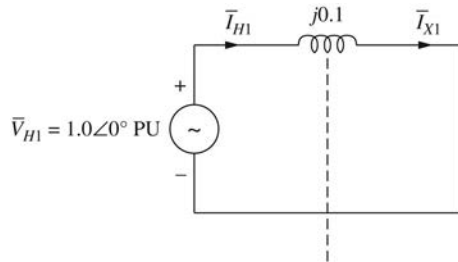

$$S_{base} = 30 \text{ MVA}$$

$$V_{base H} = 66.4\sqrt{3} = 115 \text{ kV}$$

$$\bar{I}_{H1} = \bar{I}_{X1} = \frac{1.0 \angle 0^\circ}{j0.1} = 10.0 \angle -90^\circ \text{ pu}$$

(a)  $I_{base H} = \frac{30}{115\sqrt{3}} = 0.1506 \text{ kA}$      $V_{base X} = 12.5\sqrt{3} = 21.65 \text{ kV}$

$$I_{base X} = \frac{30}{21.65\sqrt{3}} = 0.8 \text{ kA}$$

$$I_H = 10(0.1506) = 1.506 \text{ kA}$$

$$I_X = 10(0.8) = 8 \text{ kA}$$

(b)  $I_{base H} = 0.1506 \text{ kA}; V_{base X} = 12.5 \text{ kV};$

$$I_{base X} = \frac{30}{12.5\sqrt{3}} = 1.386 \text{ kA}$$

$$I_H = 1.506 \text{ kA};$$

$$I_X = 10(1.386) = 13.86 \text{ kA}$$

### 3.44

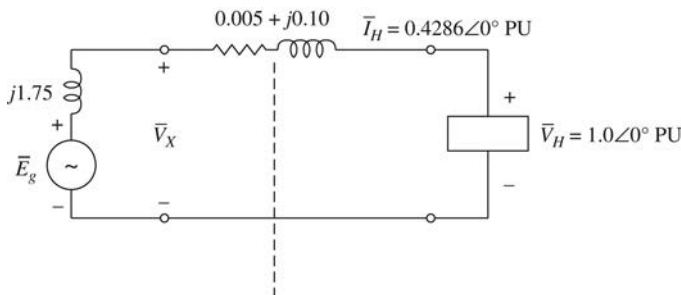

$$S_{base} = 35 \text{ MVA} \quad V_{Base H} = 115 \text{ kV}$$

$$V_{base X} = 13.2 \text{ kV}$$

(a)  $X_{g1} = 1.5 \left( \frac{35}{30} \right) = 1.75 \text{ pu}$

(b)

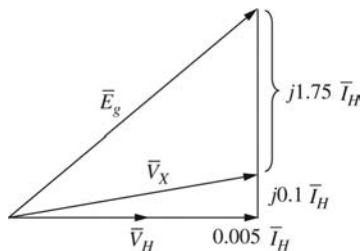



$$(c) \quad I_{baseH} = \frac{35}{115\sqrt{3}} = 0.1757 \text{ kA}; \quad \bar{I}_H = \frac{15\angle 0^\circ}{(115\sqrt{3})(1.0)} = 0.0753\angle 0^\circ \text{ kA} = 0.4286\angle 0^\circ \text{ pu}$$

$$\begin{aligned} \bar{V}_X &= 1\angle 0^\circ + (0.005 + j0.1)(0.4286\angle 0^\circ) \\ &= 1.0021 + j0.04286 = 1.003\angle 2.45^\circ \text{ pu}; \end{aligned}$$

$$V_X = 1.003(13.2) = 13.24 \text{ kV}$$

$$\bar{E}_g = 1\angle 0^\circ + (0.005 + j1.85)(0.4286\angle 0^\circ) = 1.961\angle 23.86^\circ \text{ pu};$$

$$E_g = 1.961 \times 13.2 = 25.89 \text{ kV}$$

$$P_x + jQ_x = \bar{V}_x \bar{I}_x^* = (1.003\angle 2.45^\circ)(0.4286\angle 0^\circ)$$

$$= 0.4299\angle 2.45^\circ \text{ pu} = 0.4299(35)\angle 2.45^\circ \text{ MVA}$$

$$= 15.03 \text{ MW} + j0.643 \text{ MVAR}$$

$$PF = \cos 2.45^\circ = 0.999 \text{ Lagging}$$

**3.45** Three-phase rating of transformer  $T_2$  is  $3 \times 100 = 300 \text{ MVA}$  and its line-to-line voltage ratio is  $\sqrt{3}(127) : 13.2$  or  $220 : 13.2 \text{ kV}$ . Choosing a common base of  $300 \text{ MVA}$  for the system, and selecting a base of  $20 \text{ kV}$  in the generator circuit,

The voltage base in the transmission line is  $230 \text{ kV}$  and the voltage base in the motor circuit is  $230(13.2/220) = 13.8 \text{ kV}$  transformer reactances converted to the proper base are given by

$$T_1 : X = 0.1 \times \frac{300}{350} = 0.0857; \quad T_2 : 0.1 \left( \frac{13.2}{13.8} \right)^2 = 0.0915$$

Base impedance for the transmission line is  $(230)^2/300 = 176.3 \Omega$

The reactance of the line in per unit is then  $\frac{0.5 \times 64}{176.3} = 0.1815$

Reactance  $X''_\alpha$  of motor  $M_1 : 0.2 \left( \frac{300}{200} \right) \left( \frac{13.2}{13.8} \right)^2 = 0.2745$

Reactance  $X''_\alpha$  of motor  $M_2 : 0.2 \left( \frac{300}{100} \right) \left( \frac{13.2}{13.8} \right)^2 = 0.549$

Neglecting transformer phase shifts, the positive-sequence reactance diagram is shown in figure below:

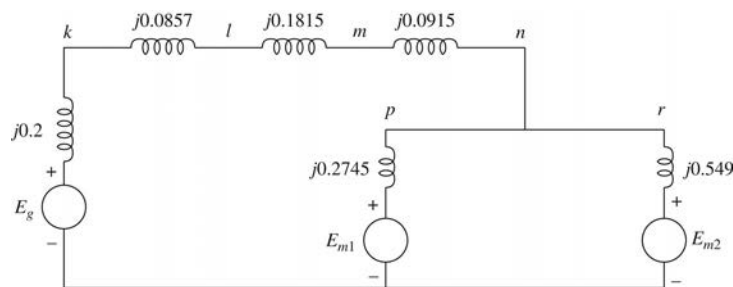

- 3.46** The motors together draw 180 MW, or  $\frac{180}{300} = 0.6$  pu

With phase-a voltage at the motor terminals as reference,

$$\bar{V} = \frac{13.2}{13.8} = 0.9565 \angle 0^\circ \text{ pu}$$

The motor current is given by

$$\bar{I} = \frac{0.6}{0.9565} \angle 0^\circ = 0.6273 \angle 0^\circ \text{ pu}$$

Referring to the reactance diagram in the solution of PR. 3-33, phase-a per-unit voltages at other points of the system are

$$\text{At } m: \bar{V} = 0.9565 + 0.6273(j0.0915) = 0.9582 \angle 3.434^\circ \text{ pu}$$

$$\text{At } l: \bar{V} = 0.9565 + 0.6273(j0.0915 + j0.1815) = 0.9717 \angle 10.154^\circ \text{ pu}$$

$$\text{At } k: \bar{V} = 0.9565 + 0.6273(j0.0915 + j0.1815 + j0.0857) = 0.9826 \angle 13.237^\circ \text{ pu}$$

The voltage regulation of the line is then

$$\frac{0.9826 - 0.9582}{0.9582} = 0.0255$$

The magnitude of the voltage at the generator terminals is

$$0.9826 \times 20 = 19.652 \text{ kV}$$

Note that the transformer phase shifts have been neglected here.

- 3.47** (a) For positive sequence operation and standard  $\Delta$ -Y connection, the per-phase diagram is shown below:

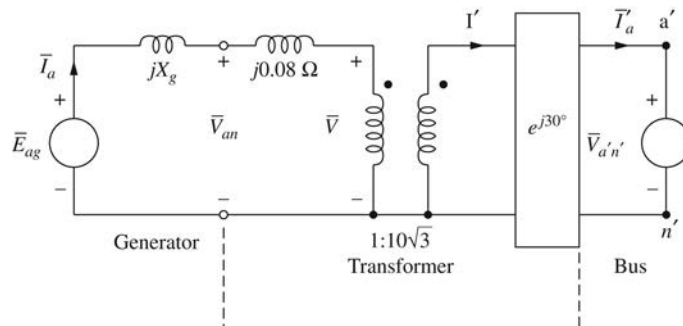

$$\bar{V}_{a'n'} = \frac{230}{\sqrt{3}} \angle 0^\circ \text{ kV, choosing that as a reference.}$$

$$\bar{S}' = \frac{100 \times 10^6}{0.8 \times 3} \angle \cos^{-1} 0.8 = 41.67 \angle 36.87^\circ \text{ MVA}$$

$$\bar{I}_a^* = \frac{\bar{S}'}{\bar{V}_{a'n'}} = \frac{41.67 \times 10^6 \angle 36.87^\circ}{132.8 \times 10^3} = 313.8 \angle 36.87^\circ \text{ A}$$

$$\therefore \bar{I}_a = 313.8 \angle -36.87^\circ \text{ A}$$

$$\bar{I}_a = 10\sqrt{3} e^{-j30^\circ} \bar{I}_a = 5435 \angle -66.87^\circ \text{ A}$$

The primary current magnitude is 5435A. ←

$$\bar{V}_{an} = \bar{V} + j0.08 \bar{I}_a = \left( \frac{1}{10\sqrt{3}} 132.8 \times 10^3 \angle -30^\circ \right) + j0.08 (5435 \angle -66.87^\circ)$$

$$= 7667.4 \angle -30^\circ + 434.8 \angle 23.13^\circ$$

$$= 7253.3 \angle -13.93^\circ \text{ V}$$

Line-to-line primary voltage magnitude =  $\sqrt{3} (7253.3) = 12.56 \text{ kV}$  ←

Three-phase complex power supplied by the generator is

$$\bar{S}_{3\phi} = 3 \bar{V}_{an} \bar{I}_a^* = 3 (7253.3 \angle -13.93^\circ) (5435 \angle 66.87^\circ)$$

$$= 118.27 \angle 52.94^\circ \text{ MVA} \leftarrow$$

- (b) The secondary phase leads the primary by 13.93°; this phase shift applies to line-to-neutral (phase) as well as line-to-line voltages. ←

- 3.48** (a) For positive sequence operation and standard  $\Delta$ -Y & Y- $\Delta$  connections, the per-phase diagram is drawn below:

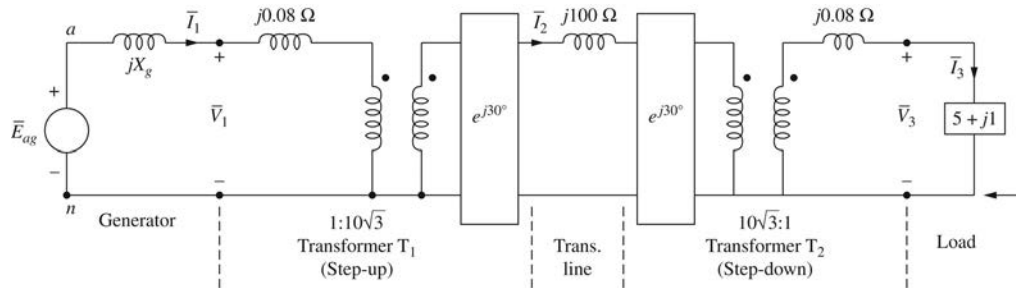

- (b)  $\bar{V}_1 = \frac{15}{\sqrt{3}} \angle 0^\circ \text{ kV}$ , choosing that as a reference.

$$\bar{Z}_3 = (5 + j1) + j0.08 = (5 + j1.08) \Omega$$

$$\bar{Z}_2 = j100 + (10\sqrt{3})^2 \bar{Z}_3 = (1500 + j424) \Omega$$

$$\bar{Z}_1 = \left[ \bar{Z}_2 / (10\sqrt{3})^2 \right] + j0.08 = 5 + j1.4933 = 5.22 \angle 16.63^\circ$$

$$\therefore \bar{I}_1 = \bar{V}_1 / \bar{Z}_1 = 8660.5 / (5.22 \angle 16.63^\circ) = 1659.1 \angle -16.63^\circ$$

Generator current magnitude =  $I_1 = 1659.1 \text{ A}$  ←

$$\bar{I}_2 = \frac{1}{10\sqrt{3}} e^{j30^\circ} \quad \bar{I}_1 = 95.8 \angle 13.37^\circ \text{ A}$$

Transmission-line current magnitude =  $95.8 \text{ A}$  ←

$$\bar{I}_3 = 10\sqrt{3} e^{-j30^\circ} \quad \bar{I}_2 = 1659.3 \angle -16.63^\circ \text{ A}$$

Load current magnitude =  $1659.3 \text{ A}$  ←

$$\begin{aligned} \bar{V}_3 &= \bar{Z}_{LOAD} \bar{I}_3 \quad \bar{I}_3 = (5 + j1)(1659.3 \angle -16.63^\circ) \\ &= 8462.4 \angle -5.32^\circ \text{ V} \end{aligned}$$

Line-to-line voltage magnitude at load terminals =  $14.66 \text{ kV}$  ←

Three-phase complex power delivered to the load is

$$\begin{aligned} \bar{S}_{3\phi} &= 3\bar{V}_3 \bar{I}_3^* = 3\bar{Z}_{LOAD} I_3^2 \\ &= 3(8462.4 \angle -5.32^\circ)(1659.3 \angle +16.63^\circ) \\ &= 42.125 \angle 11.31^\circ \text{ MVA} \leftarrow \end{aligned}$$

**3.49** Base kV in transmission-line circuit =  $132 \text{ kV}$

$$\text{Base kV in the generator } G_1 \text{ circuit} = 132 \times \frac{13.2}{165} = 10.56 \text{ kV}$$

$$\text{Base kV in the generator } G_2 \text{ circuit} = 132 \times \frac{13.8}{165} = 11.04 \text{ kV}$$

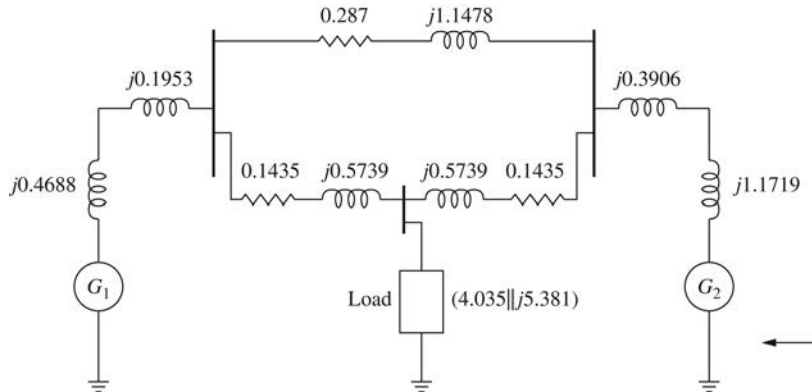

Impedance diagram of the system with pu values

On the common base of 100 MVA for the entire system,

$$G_1 : \bar{Z} = j0.15 \times \frac{100}{50} \times \left( \frac{13.2}{10.56} \right)^2 = j0.4688 \text{ pu}$$

$$G_2 : \bar{Z} = j0.15 \times \frac{100}{20} \times \left( \frac{13.8}{11.04} \right)^2 = j1.1719 \text{ pu}$$

$$T_1 : \bar{Z} = j0.1 \times \frac{100}{80} \times \left( \frac{13.2}{10.56} \right)^2 = j0.1953 \text{ pu}$$

$$T_2 : \bar{Z} = j0.1 \times \frac{100}{40} \times \left( \frac{13.8}{11.04} \right)^2 = j0.3906 \text{ pu}$$

Base impedance in transmission-line circuit is

$$\frac{(132)^2}{100} = 174.24 \Omega$$

$$\bar{Z}_{TR.LINE 1} = \frac{50 \times j200}{174.24} = 0.287 + j1.1478 \text{ pu}$$

$$\bar{Z}_{TR.LINE 2} = \frac{25 \times j100}{174.24} = 0.1435 + j0.5739 \text{ pu}$$

$$LOAD : 40(0.8 + j0.6) = (32 + j24) \text{ MVA}$$

$$R_{LOAD} = \frac{(150)^2}{32} = 703.1 \Omega = \frac{703.1}{174.24} \text{ pu} = 4.035 \text{ pu}$$

$$X_{LOAD} = \frac{(150)^2}{24} = 937.5 \Omega = \frac{937.5}{174.24} \text{ pu} = 5.381 \text{ pu}$$

$$\bar{Z}_{LOAD} = (R_{LOAD} \parallel jX_{LOAD})$$

### 3.50

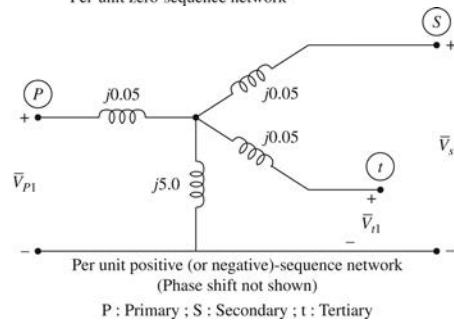
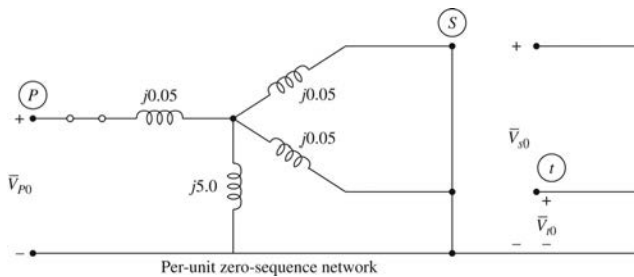

3.51 (a)  $X_{12} = 0.08$  pu;  
 $X_{13} = 0.1$  pu;  
 $X_{23} = 0.09(15/10) = 0.135$  pu

$$X_1 = \frac{1}{2}(0.08 + 0.1 - 0.135) = 0.0225 \text{ pu}$$

$$X_2 = \frac{1}{2}(0.08 + 0.135 - 0.1) = 0.0575 \text{ pu}$$

$$X_3 = \frac{1}{2}(0.135 + 0.1 - 0.08) = 0.0775 \text{ pu}$$

(b)

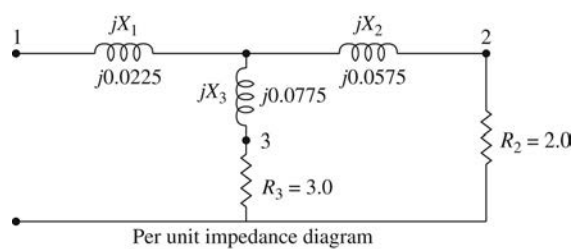

Using  $P_{3\phi} = 3V_{LN}^2/R = V_{LL}^2/R$

$$R_2 = (13.2)^2/7.5 = 23.23 \Omega; \quad R_3 = (2.3)^2/5 = 1.058 \Omega$$

$$Z_{2base} = (13.2)^2/15 = 11.616 \Omega; \quad Z_{3base} = (2.3)^2/15 = 0.3527 \Omega$$

$$R_{2pu} = R_2/Z_{2base} = \frac{23.23}{11.616} = 2 \text{ pu}; \quad R_{3pu} = \frac{1.058}{0.3527} = 3 \text{ pu}$$

3.52 (a)

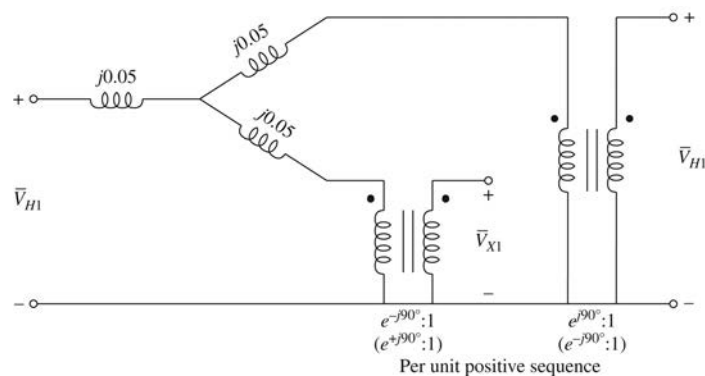

**Per unit positive sequence**

$$X_1 = X_2 = X_3 = \frac{1}{2}(0.1 + 0.1 - 0.1) \\ = 0.05 \text{ per unit}$$

(b)

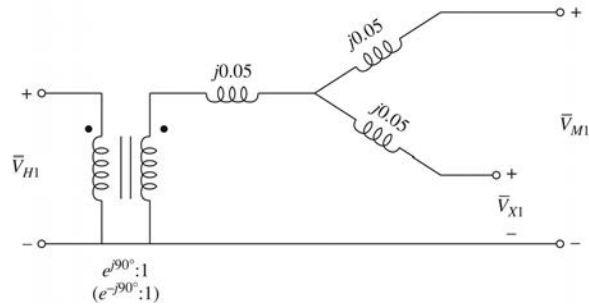

**Per unit positive sequence.**

(c)

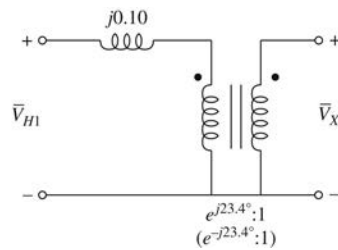

**Per unit positive sequence.**

**3.53** With a base of 15 MVA and 66 kV in the primary circuit, the base for secondary circuit is 15 MVA and 13.2 kV, and the base for tertiary circuit is 15 MVA and 2.3 kV,

Note that  $X_{ps}$  and  $X_{pt}$  need not be changed.

$X_{st}$  is modified to the new base as follows:

$$X_{st} = 0.08 \times \frac{15}{10} = 0.12$$

With the bases specified, the per-unit reactances of the per-phase equivalent circuit are given by

$$X_p = \frac{1}{2}(j0.07 + j0.09 - 0.12) = j0.02$$

$$X_s = \frac{1}{2}(j0.07 + j0.12 - j0.09) = j0.05$$

$$X_T = \frac{1}{2}(j0.09 + j0.12 - j0.07) = j0.07$$

**3.54** The constant voltage source is represented by a generator having no internal impedance. On a base of 5 MVA, 2.3 kV in the tertiary, the resistance of the load is 1.0 pu. Expressed on a

15 MVA, 2.3 kV base, the load resistance is  $R = 1.0 \times \frac{15}{5} = 3.0$  pu

On a base of 15 MVA, 13.2 kV, the reactance of the motor is

$$X'' = 0.2 \times \frac{15}{7.5} = 0.4 \text{ pu}$$

The impedance diagram is given below:

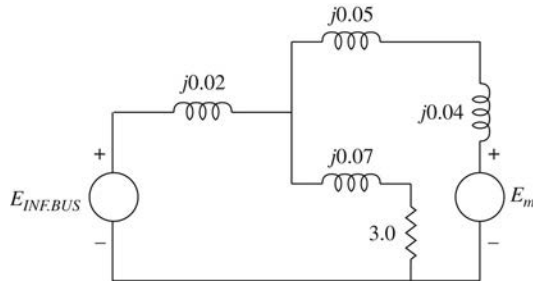

Note that the phase shift that occurs between the Y-connected primary and the Δ-connected tertiary has been neglected here.

3.55 (a)

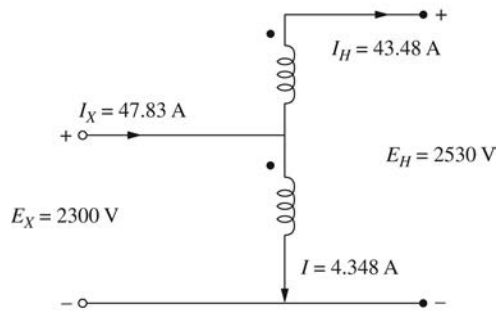

(b)  $S_X = (2300)(47.83) = \underline{\underline{110 \text{ kVA}}}$

$$S_H = 2530(43.48)$$

10 kVA is transformed by magnetic induction.

100 kVA is transformed electrically.

(c) At rated voltage, core losses = 70 W

At full-load current, winding losses =  $\left(\frac{4.348}{4.5}\right)^2 240 = 224 \text{ W}$

Total losses =  $P_{Loss} = 294 \text{ W}$

$$P_{out} = (2530)(43.48)(0.8) = 88003 \text{ W}$$

$$P_{in} = P_{out} + P_{Loss} = 88003 + 294 = 88297 \text{ W}$$

$$\% \text{ Efficiency} = (P_{out} / P_{in}) \times 100 = (88003 / 88297) 100 = 99.67 \%$$



3.56 (a)

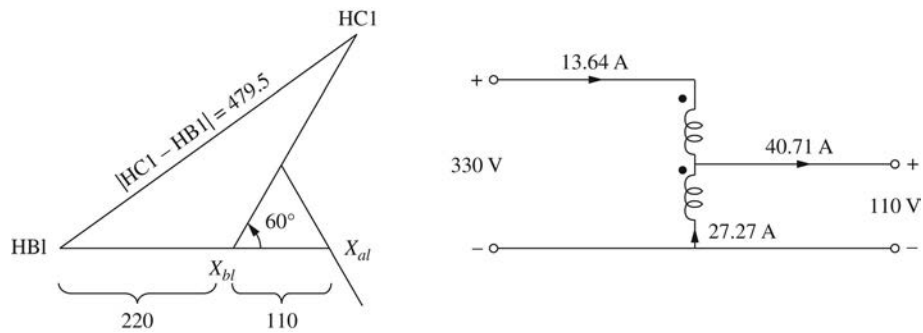

(b) As a normal, single-phase, two-winding transformer, rated: 3 kVA, 220/110 V;  
 $X_{eq} = 0.10$  per unit.  $Z_{Base Hold} = (220)^2 / 3000 = 16.133 \Omega$

As a single - phase autotransformer rated:

$$330(13.64) = 4.50 \text{ kVA}, 330 / 110 \text{ V},$$

$$Z_{Base H new} = (330)^2 / 4500 = 24.2 \Omega$$

$$X_{eq} = (0.10) \left( \frac{16.133}{24.2} \right) = 0.06667 \text{ per unit}$$

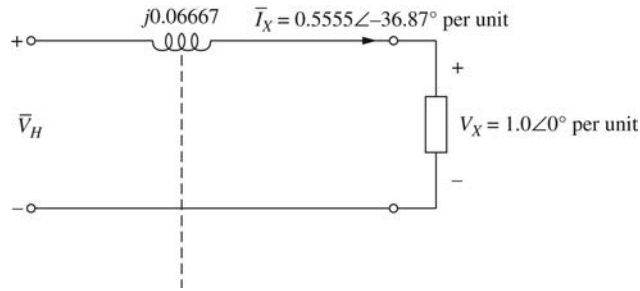

$$S_{Base 3\phi} = 13.5 \text{ kVA}$$

$$V_{Base X} = 110 \text{ V}$$

$$V_{Base H} = 479.5 \text{ V}$$

$$I_{Base X} = \frac{13.5 \times 10^3}{110\sqrt{3}} = 70.86 \text{ A}$$

$$I_{Base H} = \frac{13.5 \times 10^3}{479.5\sqrt{3}} = 16.256 \text{ A}$$

$$\bar{I}_X = \frac{6000 \angle -\cos^{-1} .8}{(110\sqrt{3})(0.8)} = 39.36 \angle -36.87^\circ \text{ A}$$

$$\bar{I}_X = \frac{39.36}{70.86} \angle -36.87^\circ = 0.5555 \angle -36.87^\circ \text{ per unit}$$

$$I_H = I_X = 0.5555 \text{ per unit}$$

$$I_H = (0.5555)(16.256) = \underline{9.031 \text{ A}}$$

$$\bar{V}_H = \bar{V}_X + jX_{eq}\bar{I}_X = 1.0 \angle 0^\circ + (j0.06667)(.5555 \angle -36.86^\circ)$$

$$\bar{V}_H = 1.0 + 0.03704 \angle 53.13^\circ = 1.0222 + j0.02963$$

$$\bar{V}_H = 1.0226 \angle 1.66^\circ \text{ per unit}$$

$$V_H = (1.0226)(479.5) = \underline{490.3 \text{ V}}$$

**3.57** Rated currents of the two-winding transformer are

$$I_1 = \frac{60,000}{240} = 250 \text{ A} \quad \text{and} \quad I_2 = \frac{60,000}{1200} = 50 \text{ A}$$

The autotransformer connection is shown below:

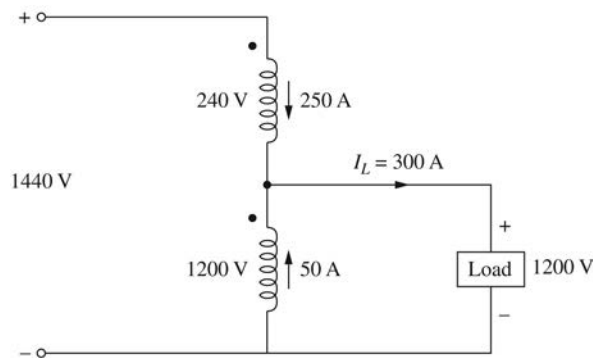

- (a) The autotransformer secondary current is  $I_L = 300 \text{ A}$   
 With windings carrying rated currents, the autotransformer rating is  $(12000)(300)10^{-3} = 360 \text{ kVA}$
- (b) Operated as a two-winding transformer at full-load,  $0.8 \text{ pf}$ ,

$$\text{Efficiency } \eta = \frac{60 \times 0.8}{(60 \times 0.8) + P_{Loss}} = 0.96$$

$$\text{From which the total transformer loss } P_{Loss} = \frac{4.8(1-0.96)}{0.96} = 2 \text{ kW}$$

The total autotransformer loss is same as the two-winding transformer, since the windings are subjected to the same rated voltages and currents as the two-winding transformer.

$$\therefore \eta_{AUTO.TR.} = \frac{360 \times 0.8}{(360 \times 0.8) + 2} = 0.9931$$

3.58 (a) The autotransformer connection is shown below:

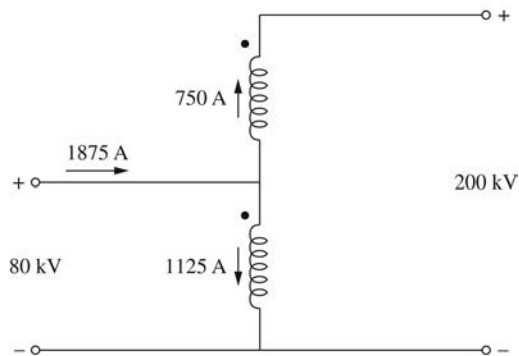

$$I_1 = \frac{90,000}{80} = 1125 \text{ A}; I_2 = \frac{90,000}{120} = 750 \text{ A}$$

$$V_1 = 80 \text{ kV}; V_2 = 120 + 80 = 200 \text{ kV}$$

$$I_{in} = 1125 + 750 = 1875 \text{ A}$$

(a) Input kVA is calculated as  $80 \times 1875 = 150,000 \text{ kVA}$  which is same as

$$\text{Output kVA} = 200 \times 750 = 150,000$$

Permissible kVA rating of the autotransformer is 150,000. The kVA transferred by the magnetic induction is same as the rating of the two-winding transformer, which is 90,000 kVA.

3.59

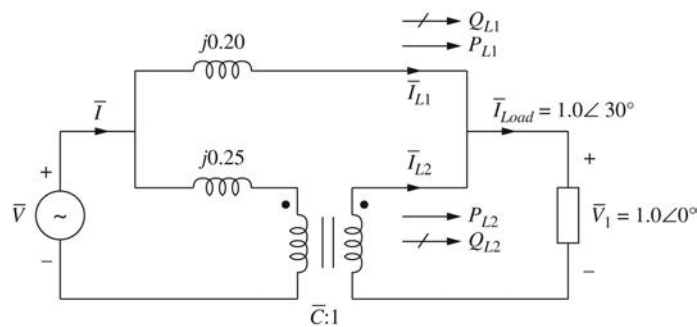

$$P_{Load} + jQ_{Load} = \bar{V} \bar{I}_{Load}^* = (1.0 \angle 0^\circ)(1.0 \angle -30^\circ)^* = 1.0 \angle 30^\circ = 0.866 + j0.50 \text{ per unit}$$

- (a) No regulating transformer,  $\bar{C} = 1.0$

Using current division:

$$\bar{I}_{L1} = \left( \frac{X_{L2}}{X_{L1} + X_{L2}} \right) \bar{I}_{Load} = \left( \frac{0.25}{0.45} \right) (1.0 \angle -30^\circ) = 0.5556 \angle -30^\circ \text{ per unit}$$

$$P_{L1} + jQ_{L1} = \bar{V} \bar{I}_{L1}^* = 0.5556 \angle +30^\circ = \underline{0.4811 + j0.2778} \text{ per unit}$$

$$P_{L2} + jQ_{L2} = (P_{Load} + jQ_{Load}) - (P_{L1} + jQ_{L1}) = (0.866 + j0.5) - (0.4811 + j0.2778) \\ = \underline{0.3849 + j0.2222} \text{ per unit}$$

- (b) Voltage magnitude regulating transformer,  $C = 0.9524$

Using the admittance parameters from Example 4.14(a)

$$\begin{bmatrix} \bar{I} \\ -1.0 \angle -30^\circ \end{bmatrix} = \begin{bmatrix} \bar{I} \\ -\bar{I}_{Load} \end{bmatrix} = \begin{bmatrix} \bar{Y}_{11} & \bar{Y}_{12} \\ \bar{Y}_{21} & \bar{Y}_{22} \end{bmatrix} \begin{bmatrix} \bar{V} \\ \bar{V}^1 \end{bmatrix} = \begin{bmatrix} -j9.0 & j8.810 \\ j8.810 & -j8.628 \end{bmatrix} \begin{bmatrix} \bar{V} \\ 1.0 \angle 0^\circ \end{bmatrix}$$

Solving the second equation above for  $\bar{V}$ :

$$-1.0 \angle -30^\circ = (j8.810) \bar{V} - (j8.628)(1.0 \angle 0^\circ)$$

$$\bar{V} = \frac{8.628 \angle 90^\circ - 1.0 \angle -30^\circ}{j8.810} = \frac{-0.866 + j9.128}{j8.810} = 1.041 \angle 5.42^\circ \text{ per unit}$$

Then:

$$\bar{I}_{L1} = \frac{\bar{V} - \bar{V}^1}{jX_{L1}} = \frac{1.041 \angle 5.42^\circ - 1.0 \angle 0^\circ}{j0.20} = \frac{0.0361 + j0.0983}{j0.20} = 0.5235 \angle -20.14^\circ$$

$$P_{L1} + jQ_{L1} = \bar{V} \bar{I}_{L1}^* = 0.5235 \angle 20.14^\circ = \underline{0.4915 + j0.1802} \text{ per unit}$$

$$P_{L2} + jQ_{L2} = (P_{Load} + jQ_{Load}) - (P_{L1} + jQ_{L1}) = \underline{0.3745 + j0.3198} \text{ per unit}$$

The voltage magnitude regulating transformer increases the reactive power delivered by line L-2 43.970 (from 0.2222 to 0.3198) with a relatively small change in the real power delivered by line L2.

- (c) Phase angle regulating transformer,  $\bar{C} = 1.0 \angle -3^\circ$

Using  $\bar{Y}_{21} = -0.2093 + j8.9945$  and  $\bar{Y}_{22} = -j9.0$  per unit from Example 4.14(b):

$$\bar{V} = \frac{-\bar{Y}_{22} \bar{V}^1 - \bar{I}_{Load}}{\bar{Y}_{21}} = \frac{(j9.0)(1.0 \angle 0^\circ) - 1.0 \angle -30^\circ}{-0.2093 + j8.9945} \\ = \frac{-0.8660 + j9.50}{-0.2093 + j8.9945} = \frac{9.539 \angle 95.21^\circ}{8.997 \angle 91.33^\circ} = 1.060 \angle 3.89^\circ \text{ per unit}$$

$$\bar{I}_{L1} = \frac{\bar{V} - \bar{V}^1}{jX_{L1}} = \frac{1.060 \angle 3.879^\circ - 1.0 \angle 0^\circ}{j0.20} = \frac{0.0578 + j0.717}{j0.20} \\ = 0.4606 \angle -38.87^\circ \text{ per unit}$$

$$P_{L1} + jQ_{L1} = \bar{V} \bar{I}_{L1}^* = 0.4606 \angle +38.87^\circ = \underline{\underline{0.3586 + j0.2890}}$$

$$P_{L2} + jQ_{L2} = (P_{Load} + jQ_{Load}) - (P_{L1} + jQ_{L1}) = \underline{\underline{0.5074 + j0.2110}}$$

The phase-angle regulating transformer increases the real power delivered by line *L2* 31.8% (from 0.3849 to 0.5074) with a relatively small change in the reactive power delivered by line *L2*.

- 3.60** Losses are minimum at 0 degrees = 16.606 MW (there can be a +/- 0.1 variation in this value values of the power flow solution tolerance).

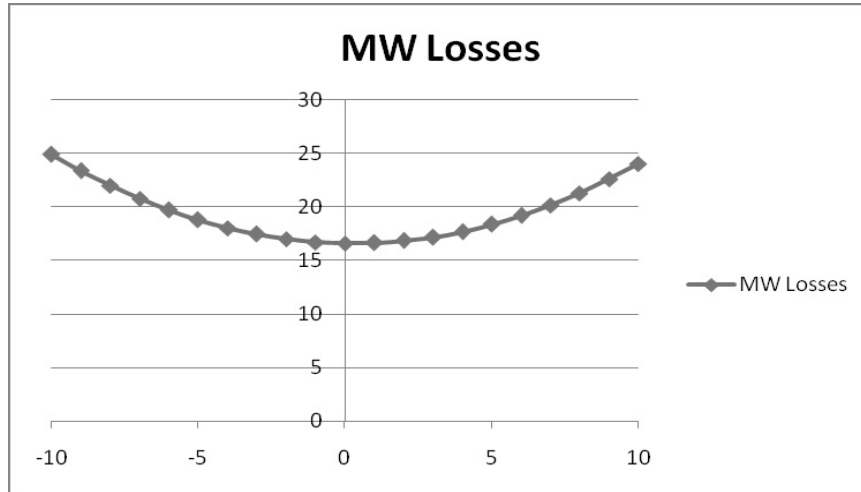

- 3.61** Minimum occurs at a tap of 1.0 = 16.604 (there can be a +/- 0.1 variation in this value values of the power flow solution tolerance).

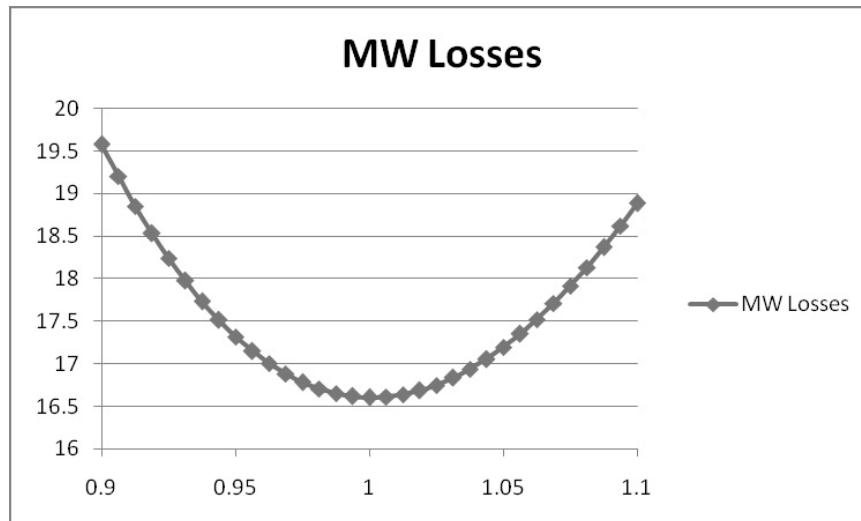

**3.62** Using (3.8.1) and (3.8.2)

$$a_t = \frac{13.8}{345(1.1)} = 0.03636 \quad b = \frac{13.8}{345} = 0.04$$

$$c = a_t / b = 0.03636 / 0.04 = 0.90909$$

From Figure 3.25(a):

$$c\bar{Y}_{eq} = (0.90909) \left( \frac{1}{j0.05} \right) = -j18.18 \text{ per unit}$$

$$(1-c)\bar{Y}_{eq} = (0.0909) \left( \frac{1}{j0.05} \right) = -j1.818 \text{ per unit}$$

$$(|c|^2 - c)\bar{Y}_{eq} = (0.82645 - 0.90909) \left( \frac{1}{j0.05} \right) = +j1.6529 \text{ per unit}$$

The per-unit positive-sequence network is:

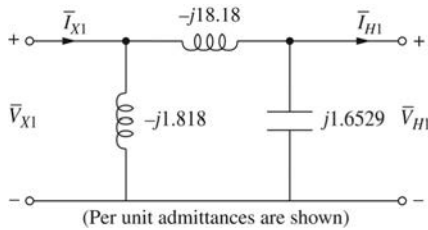

**3.63** A radial line with tap-changing transformers at both ends is shown below:

Is shown below:

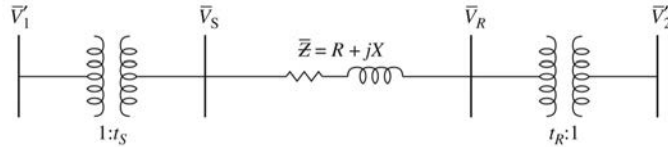

$\bar{V}'_1$  and  $\bar{V}'_2$  are the supply phase voltage and the load phase voltage, respectively, referred to the high-voltage side.  $\bar{V}_s$  and  $\bar{V}_R$  are the phase voltages at both ends of the line.  $t_s$  and  $t_R$  are the tap settings in per unit. The impedance  $\bar{Z}$  includes the line impedance plus the referred impedances of the sending end and the receiving end transformers to the high-voltage side. After drawing the voltage phasor diagram for the KVL  $\bar{V}_s = \bar{V}_R + (R + jX)\bar{I}$ , neglecting the phase shift between  $\bar{V}_s$  and  $\bar{V}_R$  as an approximation, and noting that  $\bar{V}_s = t_s \bar{V}'_1$  and  $\bar{V}_R = t_R \bar{V}'_2$ , it can be shown that

$$t_s = \sqrt{\frac{|\bar{V}'_2|/|\bar{V}'_1|}{1 - \frac{RP_\phi + XQ_\phi}{|\bar{V}'_1||\bar{V}'_2|}}}$$

where  $P_\phi$  and  $Q_\phi$  are the load real and reactive powers per phase and it is assumed that  $t_S t_R = 1$ .

In our problem, 
$$P_\phi = \frac{1}{3}(150 \times 0.8) = 40 \text{ MW}$$

and 
$$Q_\phi = \frac{1}{3}(150 \times 0.6) = 30 \text{ MVAR}$$

$$|\bar{V}_1| = |\bar{V}_2| = \frac{230}{\sqrt{3}} \text{ kV}$$

$t_S$  is calculated as 
$$k_S = \sqrt{\frac{1}{1 - \frac{(18)(40) + (60)(30)}{(230/\sqrt{5})^2}}} = 1.08 \text{ pu}$$

and 
$$t_R = \frac{1}{1.08} = 0.926 \text{ pu}$$

**3.64** With the tap setting  $t = 1.05$ ,  $\Delta V = t - 1 = 0.05 \text{ pu}$

The current setup by  $\Delta \bar{V} = 0.05 \angle 0^\circ$  circulates around the loop with switch  $S$  open; with  $S$  closed, only a very small fraction of that current goes through the load impedance, because it is much larger than the transformer impedance; so the superposition principle can be applied to  $\Delta \bar{V}$  and the source voltage.

From  $\Delta \bar{V}$  Alone,  $I_{CIRC} = 0.05 / j0.2 = -j0.25$

With  $\Delta \bar{V}$  shorted, the current in each path is one-half the load current.

Load current is 
$$\frac{1.0}{0.8 + j0.6} = 0.8 - j0.6$$

Superposition yields:  $\bar{I}_{T_a} = 0.4 - j0.3 - (-j0.25) = 0.4 - j0.05$

$$\bar{I}_{T_b} = 0.4 - j0.3 + (-j0.25) = 0.4 - j0.55$$

So that  $\bar{S}_{T_a} = 0.4 + j0.05 \text{ pu}$  and  $\bar{S}_{T_b} = 0.4 + j0.55$

The transformer with the higher tap setting is supplying most of the reactive power to the load. The real power is divided equally between the transformers.

**Note:** An error in printing: In the fourth line of the problem statement, first  $T_b$  should be replaced by  $T_a$  and within brackets,  $T_a$  should be replaced by  $T_b$ .

**3.65** Same procedure as in PR. 3.49 is followed.

Now  $t = 1.0 \angle 3^\circ$

So  $t - 1 = 1.0 \angle 3^\circ - 1 \angle 0^\circ = 0.0524 \angle 91.5^\circ$

$$\bar{I}_{CIRC} = \frac{0.0524 \angle 91.5^\circ}{0.2 \angle 90^\circ} = 0.262 + j0.0069$$

Then  $\bar{I}_{T_a} = 0.4 - j0.3 - (0.262 + j0.0069) = 0.138 - j0.307$

$$\bar{I}_{T_b} = 0.4 - j0.3 + (0.262 + j0.0069) = 0.662 - j0.293$$

So

$$\bar{S}_{T_a} = 0.138 + j0.307; \bar{S}_{T_b} = 0.662 + j0.293$$

The phase shifting transformer is useful to control the amount of real power flow; out has less effect on the reactive power flow.





# Chapter 4

## Transmission-Line Parameters

### ANSWERS TO MULTIPLE-CHOICE TYPE QUESTIONS

- 4.1 c
- 4.2 a
- 4.3 a
- 4.4 Bundle
- 4.5 a
- 4.6 a
- 4.7  $d^2$
- 4.8 a
- 4.9 (i) a  
(ii) b
- 4.10 a
- 4.11 a
- 4.12 c
- 4.13 b
- 4.14 a
- 4.15 a
- 4.16 a
- 4.17 a
- 4.18 b
- 4.19  $\sqrt[6]{(D_{11'}D_{12'})(D_{21'}D_{22'})(D_{31'}D_{32'})}$
- 4.20 a
- 4.21  $L_x = 2 \times 10^{-7} \ln \frac{D_{xy}}{D_{xx}} \text{ H/m}$
- 4.22 Transposition
- 4.23  $D_{eq} = \sqrt[3]{D_{12}D_{23}D_{31}};$   
 $L_a = 2 \times 10^{-7} \ln \frac{D_{eq}}{D_s} \text{ H/m}$
- 4.24 Reduces the electric field strength at the conductor surfaces and hence reduces corona, power loss, communication interference, and audible noise.
- 4.25 a
- 4.26 b
- 4.27 b
- 4.28  $(2\pi\epsilon) / \ln(D/r)$
- 4.29 a
- 4.30 a
- 4.31 a
- 4.32 Charging current
- 4.33  $\omega C_m V_{LL}^2$
- 4.34 Images
- 4.35 a
- 4.36 Corona
- 4.37 20
- 4.38 a
- 4.39 b

$$4.1 \quad R_{dc,20^{\circ}\text{C}} = \frac{P_{20^{\circ}\text{C}} l}{A} = \frac{(17.00)(1000 \times 1.02)}{1113 \times 10^3} = 0.01558 \Omega / 1000'$$

$$R_{dc,50^{\circ}\text{C}} = R_{dc,20^{\circ}\text{C}} \left( \frac{50 + T}{20 + T} \right) = (0.01558) \left( \frac{50 + 228.1}{20 + 228.1} \right) = 0.01746 \Omega / 1000'$$

$$\frac{R_{60\text{HZ},50^{\circ}\text{C}}}{R_{dc,50^{\circ}\text{C}}} = \frac{0.0956 \Omega / \text{mi}}{\left( 0.01746 \frac{\Omega}{1000'} \right) \left( 5.28 \frac{1000'}{\text{mi}} \right)} = \frac{0.0956}{0.0922} = 1.0368$$

The 60HZ resistance is 3.68% larger than the dc resistance, due to skin effect.

$$4.2 \quad R_1 = 50 \Omega \text{ at } T_1 = 20^{\circ}\text{C}; R_2 = 50 + (0.1 \times 50) = 55 \Omega \text{ at } T_2 = ?$$

$$55 = 50 \left[ 1 + 0.00382(T_2 - 20) \right]$$

$$T_2 = 25.24^{\circ}\text{C} \leftarrow$$

$$4.3 \quad l = 1.05 \times 3000 = 3150 \text{ m}, \text{ Allowing for the twist.}$$

$$\text{X-sectional area of all 19 strands} = 19 \times \frac{\pi}{4} \times (1.5 \times 10^{-3})^2 = 33.576 \times 10^{-6} \text{ m}^2.$$

$$R = \frac{Pl}{A} = \frac{1.72 \times 10^{-8} \times 3150}{33.576 \times 10^{-6}} = 1.614 \Omega \leftarrow$$

$$4.4 \quad (a) \quad 795 \text{ MCM} = (795 \times 10^3 \text{ cmil}) \left( \frac{\frac{\pi}{4} \text{ sq} \cdot \text{mil}}{1 \text{ cmil}} \right) \left( \frac{1 \text{ in}}{1000 \text{ mil}} \right)^2 \left( \frac{0.0254 \text{ m}}{1 \text{ in}} \right)^2$$

$$= 4.0283 \times 10^{-4} \text{ m}^2$$

$$(b) \quad R_{60\text{HZ},50^{\circ}\text{C}} = R_{60\text{HZ},75^{\circ}\text{C}} \left( \frac{50 + T}{75 + T} \right)$$

$$= 0.0880 \left( \frac{50 + 228.1}{75 + 228.1} \right)$$

$$= 0.0807 \Omega / \text{km}$$

$$4.5 \quad \text{From Table A-4}$$

$$R_{60\text{HZ},50^{\circ}\text{C}} = \left( 0.1185 \frac{\Omega}{\text{mi}} \right) \left( \frac{1 \text{ mi}}{1.609 \text{ km}} \right) = 0.07365 \Omega / \text{km}$$

per conductor (at 75% current capacity)

For 4 conductors per phase:

$$R_{60\text{HZ},50^{\circ}\text{C}} = \frac{0.07365}{4} = 0.01841 \Omega / \text{km per phase}$$

**4.6** Total transmission line loss  $P_L = \frac{2.5}{100}(190.5) = 4.7625 \text{ MW}$

$$I = \frac{190.5 \times 10^3}{\sqrt{3}(220)} = 500 \text{ A}$$

From  $P_L = 3I^2R$ , the line resistance per phase is

$$R = \frac{4.7625 \times 10^6}{3(500)^2} = 6.35 \Omega$$

The conductor cross-sectional area is given by

$$A = \frac{(2.84 \times 10^{-8})(63 \times 10^3)}{6.35} = 2.81764 \times 10^{-4} \text{ m}^2$$

$$\therefore d = 1.894 \text{ cm} = 0.7456 \text{ in} = 556,000 \text{ cmil}$$

**4.7** The maximum allowable line loss =  $I^2R = (100)^2 R = 60 \times 10^3$ ,

For which  $R = 6 \Omega$

$$R = \frac{Pl}{A} \text{ or } A = \frac{Pl}{R} = \frac{1.72 \times 10^{-8} \times 60 \times 10^3}{6} = 0.172 \times 10^{-3} \text{ m}^2$$

$$\frac{\pi}{4}d^2 = 0.172 \times 10^{-3} \times 10^4 \text{ cm}^2 \text{ or } d = 1.48 \text{ cm} \leftarrow$$

**4.8** (a) From Eq. (4.4.10)

$$L_{\text{int}} = \left( \frac{1}{2} \times 10^{-7} \frac{\text{H}}{\text{m}} \right) \left( \frac{1000 \text{ m}}{1 \text{ km}} \right) \left( \frac{1000 \text{ mH}}{1 \text{ H}} \right) = 0.05 \text{ mH/km Per Conductor}$$

(b) From Eq. (4.5.2)

$$L_x = L_y = 2 \times 10^{-7} \text{ Ln} \left( \frac{D}{\Gamma'} \right) \frac{\text{H}}{\text{m}}$$

$$D = 0.5 \text{ m } \Gamma' = e^{\frac{-1}{4}} \left( \frac{0.015}{2} \right) = 5.841 \times 10^{-3} \text{ m}$$

$$L_x = L_y = 2 \times 10^{-7} \text{ Ln} \left( \frac{0.5}{5.841 \times 10^{-3}} \right) \frac{\text{H}}{\text{m}} \left( \frac{1000 \text{ m}}{\text{km}} \right) \left( \frac{1000 \text{ mH}}{\text{H}} \right)$$

$$= \underline{\underline{0.8899}} \frac{\text{mH}}{\text{km}} \text{ per conductor}$$

(c)  $L = L_x + L_y = \underline{\underline{1.780}} \frac{\text{mH}}{\text{km}} \text{ per circuit}$

**4.9** (a)  $L_{\text{int}} = 0.05 \text{ mH/km Per Conductor}$

$$L_x = L_y = 2 \times 10^{-7} \ln \left( \frac{0.5}{1.2 \times 5.841 \times 10^{-3}} \right) 10^6 = 0.8535 \text{ mH/km Per Conductor}$$

$$L = L_x + L_y = 1.707 \text{ mH/km Per Circuit}$$

(b)  $\bar{\lambda}_{12(I_c)} = 0.2 \bar{I}_c \ln \frac{D_{e2}}{D_{c1}} \text{ mWb/km}$

$$L_x = L_y = 2 \times 10^{-7} \ln \left( \frac{0.5}{0.8 \times 5.841 \times 10^{-3}} \right) 10^6 = 0.9346 \text{ mH/km Per Conductor}$$

$$L = L_x + L_y = 1.869 \text{ mH/km Per Circuit.}$$

$L_{\text{int}}$  is independent of conductor diameter.

The total inductance decreases 4.1% (increases 5%) at the conductor diameter increases 20% (decreases 20%).

**4.10** From Eq. (4.5.10)

$$L_1 = 2 \times 10^{-7} \ln \left( \frac{D}{r'} \right) \frac{\text{H}}{\text{m}} \quad D = 4 \text{ ft}$$

$$L_1 = 2 \times 10^{-7} \ln \left( \frac{4}{1.6225 \times 10^{-2}} \right) \quad r' = e^{-1} \left( \frac{.5}{2} \right) \left( \frac{1 \text{ ft}}{12 \text{ in}} \right)$$

$$L_1 = \underline{1.101 \times 10^{-6}} \frac{\text{H}}{\text{m}} \quad r' = 1.6225 \times 10^{-2} \text{ ft}$$

$$X_1 = \omega L_1 = (2\pi 60)(1.101 \times 10^{-6})(1000) = \underline{0.4153 \Omega / \text{km}}$$

**4.11** (a)  $L_1 = 2 \times 10^{-7} \ln \left( \frac{4.8}{1.6225 \times 10^{-2}} \right) = 1.138 \times 10^{-6} \text{ H/m}$

$$X_1 = \omega L_1 = 2\pi(60)(1.138 \times 10^{-6})(1000) = 0.4292 \Omega / \text{km}$$

(b)  $L_1 = 2 \times 10^{-7} \ln \left( \frac{3.2}{1.6225 \times 10^{-2}} \right) = 1.057 \times 10^{-6} \text{ H/m}$

$$X_1 = 2\pi(60)(1.057 \times 10^{-6})(1000) = 0.3986 \Omega / \text{km}$$

$L_1$  and  $X_1$  increase by 3.35% (decrease by 4.02%) as the phase spacing increases by 20% (decreases by 20%).

**4.12** For this conductor, Table A.4 lists GMR to be 0.0217 ft.

$$\therefore \text{For one conductor, } L_x = 2 \times 10^{-7} \ln \frac{20}{0.0217} \text{ H/m}$$

The inductive reactance is then  $[2\pi(60)L_x] \Omega / \text{m}$

$$\text{or } 2.022 \times 10^{-3} (60) \ln \frac{20}{0.0217} \Omega / \text{mi} = 0.828 \Omega / \text{mi}$$

For the single-phase line,  $2 \times 0.828 = 1.656 \Omega / \text{mi}$

**4.13** (a) The total line inductance is given by

$$L_T = \left[ 4 \times 10^{-4} \ln \frac{D}{r'} \right] \text{mH/m}$$

$$= 4 \times 10^{-4} \ln \frac{3.6}{(0.7788)(0.023)} = 0.0021 \text{mH/m}$$

(b) The total line reactance is given by

$$X_T = 2\pi(60)4 \times 10^{-4} \ln \frac{D}{r'}$$

$$= 0.1508 \ln \frac{D}{r'} \Omega/\text{km}$$

or  $0.2426 \ln \frac{D}{r'} \Omega/\text{mi}$

$$\therefore X_T = 0.787 \Omega/\text{km} \text{ or } 1.266 \Omega/\text{mi}$$

(c)  $L_T = 4 \times 10^{-4} \ln \frac{7.2}{0.7788(0.025)} = 0.002365 \text{ mH/m}$

Doubling the separation between the conductors causes only about a 13% rise in inductance.

**4.14** (a) Eq. (4.5.9):  $L = 2 \times 10^{-7} \ln \frac{D}{r'} \text{H/m Per Phase}$

$$X = \omega L = 4\pi f \times 10^{-7} \ln(D/r') \Omega/\text{m/Phase}$$

$$= f \cdot \Delta\pi \times 10^{-7} (1609.34) \ln(D/r') \Omega/\text{MILE/PH.}$$

$$= f \cdot 4\pi (1609.34) (2.3026) 10^{-7} \log(D/r') \Omega/\text{mi/ph.}$$

$$= 4.657 \times 10^{-3} f \log(D/r') \Omega/\text{mi/ph.}$$

$$= 0.2794 \log(D/r') \Omega/\text{mi/ph. at } f = 60 \text{HZ.}$$

$$\therefore X = k \log\left(\frac{D}{r'}\right) = k \log D + k \log\left(\frac{1}{r'}\right), \text{ Where } k = 4.657 \times 10^{-3} f \quad \leftarrow$$

(b)  $r' = r \cdot e^{-1/4} = 0.06677(0.7788) = 0.052 \text{ft.}$

$$X_a = k \log \frac{1}{r'} = 0.2794 \log\left(\frac{1}{0.052}\right) = 0.35875$$

$$X_d = k \log D = 0.2794 \log(10) = 0.2794$$

$$X = X_a + X_d = 0.63815 \Omega/\text{mi/ph.} \quad \leftarrow$$

When spacing is doubled,  $X_d = 0.36351$  and  $X = 0.72226 \Omega/\text{mi/ph.} \quad \leftarrow$

**4.15** For each of six outer conductors:

$$\begin{aligned} D_{11} &= r' = e^{-\frac{1}{7}} r \\ D_{12} &= D_{16} = D_{17} = 2r \\ D_{13} &= D_{15} = 2\sqrt{3}r \\ D_{14} &= 4r \end{aligned}$$

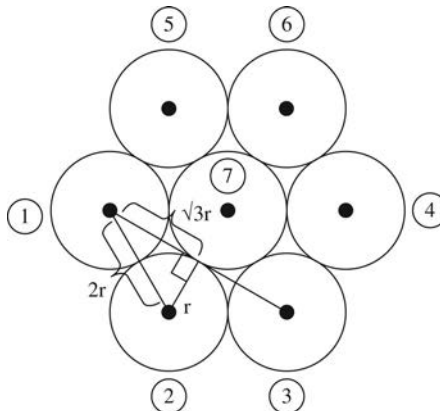

For the inner conductor:

$$\begin{aligned} D_{77} &= \Gamma^1 = e^{-\frac{1}{4}} r \\ D_{71} &= D_{72} = D_{73} = D_{74} = D_{75} = D_{76} = 2r \end{aligned}$$

$$D_s = GMR = \sqrt[49]{\underbrace{\left( e^{-\frac{1}{4}} r \right) (2r)^3 (2\sqrt{3}r)^2 (4r)}_{\text{Distances for each Outer conductor}} \uparrow 6 \underbrace{\left( e^{-\frac{1}{4}} r \right) (2r)^6}_{\text{Distances for inner conductor}}}$$

$$D_s = GMR = r \sqrt[49]{\left( e^{-\frac{1}{4}} \right)^6 (2)^{18} (2\sqrt{3})^{12} (4)^6 \left( e^{-\frac{1}{4}} \right) (2)^6}$$

$$D_s = GMR = r \sqrt[49]{\left( e^{-\frac{1}{4}} \right)^7 (2)^{24} (2\sqrt{3})^{12} (4)^6} = \underline{\underline{2.177 r}}$$

**4.16**  $D_{SL} = \sqrt[2]{N_b} \sqrt{(D_{11} D_{12} \dots D_{1N_b})^{N_b}} = (D_{11} D_{12} \dots D_{1N_b})^{\frac{1}{N_b}}$

$$D_{11} = D_s \quad D_{1n} = 2A \sin \left[ \frac{(n-1)\pi}{N_b} \right] \quad n = 2, 3, \dots, N_b$$

$$D_{SL} = \left\{ D_s \left[ 2A \sin \left( \frac{\pi}{N_b} \right) \right] \left[ 2A \sin \left( \frac{2\pi}{N_b} \right) \right] \left[ 2A \sin \left( \frac{3\pi}{N_b} \right) \right] \dots \left[ 2A \sin \left( \frac{N_b-1}{N_b} \right) \pi \right] \right\}^{\frac{1}{N_b}}$$

Using the trigonometric identity,

$$D_{SL} = \left\{ D_s (A)^{(N_b-1)} N_b \right\}^{\frac{1}{N_b}} \text{ which is the desired result.}$$

Two-conductor bundle,  $N_b = 2$

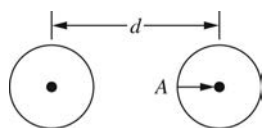

$$A = \frac{d}{2} \quad D_{SL} = \left[ D_s \left( \frac{d}{2} \right) (2) \right]^{1/2}$$

$$= \sqrt{D_s d} \quad \text{Eq (4.6.19)}$$

Three-conductor bundle,  $N_b = 3$

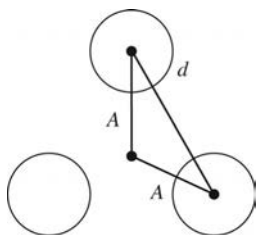

$$A = \frac{d}{\sqrt{3}} \quad D_{SL} = \left[ D_s \left( \frac{d}{\sqrt{3}} \right)^2 3 \right]^{1/3}$$

$$= \sqrt[3]{D_s d^2} \sqrt[4]{\left( \frac{4}{2\sqrt{2}} \right)} \quad \text{Eq (4.6.20)}$$

Four-conductor bundle,  $N_b = 4$

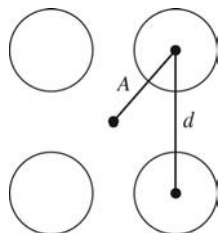

$$A = \frac{d}{\sqrt{2}} \quad D_{SL} = \left[ D_s \left( \frac{d}{\sqrt{2}} \right)^3 4 \right]^{1/4}$$

$$= \sqrt[4]{D_s d^3} \sqrt[4]{\left( \frac{4}{2\sqrt{2}} \right)}$$

$$= 1.0905 \sqrt[4]{D_s d^3} \quad \text{Eq (4.6.21)}$$

4.17 (a) 
$$GMR = \sqrt[9]{\left[ \left( e^{-\frac{1}{4}r} \right) (2r)(2r) \right]^3} = r \sqrt[3]{4e^{-\frac{1}{4}}}$$

$$= \underline{\underline{1.4605 r}}$$

(b) 
$$GMR = \sqrt[16]{\left[ \underbrace{\left( e^{-\frac{1}{4}r} \right) (2r)(4r)(6r)}_{\text{Distances for each outer conductor}} \right]^2 \left[ \underbrace{\left( e^{-\frac{1}{4}r} \right) (2r)(2r)(4r)}_{\text{Distances for each inner conductor}} \right]^2}$$

$$GMR = \sqrt[16]{\left( e^{-\frac{1}{4}} \right)^4 (2)^6 (4)^4 (6)^2 (r)} = \underline{\underline{2.1554r}}$$



$$(c) \quad GMR = r \sqrt[81]{\left[ \underbrace{\left( e^{-\frac{1}{4}} \right) (2)^2 (4)^2 (\sqrt{20})^2 (\sqrt{8}) (\sqrt{32})}_{\text{Distances for each corner conductor}} \right]^4 \times \left[ \underbrace{\left( e^{-\frac{1}{4}} \right) (2)^3 (\sqrt{8})^2 (\sqrt{20})^2 (4)}_{\text{Distances for each outside non-corner conductor}} \right]^4 \times \left[ \underbrace{\left( e^{-\frac{1}{4}} \right) (2)^4 (\sqrt{8})^4}_{\text{Distances for the center conductor}} \right]^4}$$

$$GMR = r \sqrt[81]{\left( e^{-\frac{1}{4}} \right)^9 (2)^{24} (\sqrt{8})^{16} (\sqrt{20})^{16} (4)^{12} (\sqrt{32})^4}$$

$$\underline{\underline{GMR = 2.6374r}}$$

**4.18**  $D_{eq} = \sqrt[3]{8 \times 8 \times 16} = 10.079 \text{ m}$

From Table A.4,  $D_s = (0.0403 \text{ ft}) \frac{1 \text{ m}}{3.28 \text{ ft}} = 0.0123 \text{ m}$

$$L_i = 2 \times 10^{-7} \ln(D_{eq} / D_s) = 2 \times 10^{-7} \ln\left(\frac{10.079}{0.0123}\right) = 1.342 \times 10^{-6} \text{ H/m}$$

$$X_1 = 2\pi(60)L_1 = 2\pi(60)1.342 \times 10^{-6} \frac{\Omega}{\text{m}} \times \frac{1000 \text{ m}}{1 \text{ km}} = 0.506 \Omega / \text{km}$$

**4.19** (a)  $L_1 = 2 \times 10^{-7} \ln\left(\frac{10.079 \times 1.1}{0.0123}\right) = 1.361 \times 10^{-6} \text{ H/m}$

$$X_1 = 2\pi(60)1.361 \times 10^{-6} (1000) = 0.513 \Omega / \text{km}$$

(b)  $L_1 = 2 \times 10^{-7} \ln\left(\frac{10.079 \times 0.9}{0.0123}\right) = 1.321 \times 10^{-6} \text{ H/m}$

$$X_1 = 2\pi(60)1.321 \times 10^{-6} (1000) = 0.498 \Omega / \text{km}$$

The positive sequence inductances  $L_1$  and inductive reactance  $X_1$  increase 1.4% (decrease 1.6%) as the phase spacing increases 10% (decreases 10%).

**4.20**  $D_{eq} = \sqrt[3]{10 \times 10 \times 20} = 12.6 \text{ m}$

From Table A.4,  $D_s = (0.0435 \text{ ft}) \frac{1 \text{ m}}{3.28 \text{ ft}} = 0.0133 \text{ m}$

$$X_1 = \omega L_1 = 2\pi(60)2 \times 10^{-7} \ln\left(\frac{12.6}{0.0149}\right) \frac{\Omega}{\text{m}} \times \frac{1000 \text{ m}}{1 \text{ km}}$$

$$= 0.335 \Omega / \text{km}$$

4.21 (a) From Table A.4:

$$D_s = (0.0479) \left( \frac{1}{3.28} \right) = 0.0146 \text{ m}$$

$$D_{SL} = \sqrt[3]{(0.0146)(0.457)^2} = 0.145 \text{ m}$$

$$X_1 = (2\pi 60) \left[ 2 \times 10^{-7} \text{Ln} \left( \frac{12.60}{0.145} \right) \right] \times 1000 = \underline{\underline{0.337}} \frac{\Omega}{\text{km}}$$

(b)  $D_s = (0.0391) \left( \frac{1}{3.28} \right) = 0.0119 \text{ m}$

$$D_{SL} = \sqrt[3]{(0.0119)(.457)(.457)} = 0.136 \text{ m}$$

$$X_1 = (2\pi 60) \left[ 2 \times 10^{-7} \text{Ln} \left( \frac{12.60}{0.136} \right) \right] \times 1000 = \underline{\underline{0.342}} \frac{\Omega}{\text{km}}$$

Results			
ACSR Conductor	Aluminum Cross Section	$X_1$	
	kcmil	$\Omega/\text{km}$	% change
Canary	900	0.342	} 0.9%
Finch	1113	0.339	
Martin	1351	0.337	} 0.69%

4.22 Application of Eq. (4.6.6) yields the geometric mean distance that separates the two bundles:

$$D_{AB} = \sqrt[9]{(6.1)^2 (6.2)^2 (6.3)6(6.05)(6.15)(6.25)} = 6.15 \text{ m}$$

The geometric mean radius of the equilateral arrangement of line A is calculated using Eq. (4.6.7):

$$R_A = \sqrt[9]{(0.015576)^3 (0.1)^6} = 0.0538 \text{ m}$$

In which the first term beneath the radical is obtained from

$$r' = 0.7788 \quad r = 0.7788(0.02) = 0.015576 \text{ m}$$

The geometric mean radius of the line B is calculated below as per its configuration:

$$R_B = \sqrt[9]{(0.015576)^3 (0.1)^4 (0.2)^2} = 0.0628 \text{ m}$$

The actual configuration can now be replaced by the two equivalent hollow conductors each with its own geometric mean radius and separated by the geometric mean distance as shown below:

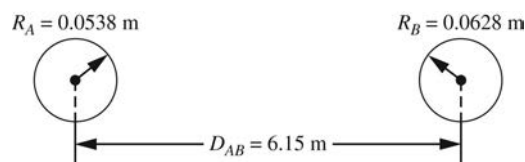

**4.23** (a) The geometric mean radius of each phase is calculated as

$$R = \sqrt[4]{(r')^2 (0.3)^2} \text{ where } r' = 0.7788 \times 0.0074 \\ = 0.0416 \text{ m}$$

The geometric mean distance between the conductors of phases A and B is given by

$$D_{AB} = \sqrt[4]{6^2 (6.3)(5.7)} = 5.996 \approx 6 \text{ m}$$

Similarly,  $D_{BC} = \sqrt[4]{6^2 (6.3)(5.7)} = 5.996 \approx 6 \text{ m}$

and  $D_{CA} = \sqrt[4]{12^2 (12.3)(11.7)} = 11.998 \approx 12 \text{ m}$

The GMD between phases is given by the cube root of the product of the three-phase spacings.

$$D_{eq} = \sqrt[3]{6 \times 6 \times 12} = 7.56 \text{ m}$$

The inductance per phase is found as

$$L = 0.2 \ln \frac{7.56}{0.0416} = 1.041 \text{ mH/km}$$

or  $L = 1.609 \times 1.041 = 1.674 \text{ mH/mi}$

(b) The line reactance for each phase then becomes

$$X = 2\pi f L = 2\pi (60) 1.674 \times 10^{-3} = 0.631 \Omega / \text{mi per phase}$$

**4.24** From the ACSR Table A.4 of the text, conductor GMR = 0.0244 ft.

Conductor diameter = 0.721 in.; since  $\sqrt{(40)^2 + (16)^2} = 43.08$ ,

GMD between phases =  $[(43.08)(80)(43.08)]^{1/3} = 52.95 \text{ in.}$

(i)  $\therefore X = k \log \frac{D}{r'} = 0.2794 \log \left( \frac{52.95/12}{0.0244} \right) = 0.6307 \Omega / \text{mi} \leftarrow$

(ii)  $L = 2 \times 10^{-7} \ln \left( \frac{52.95/12}{0.0244} \right) = 10.395 \times 10^{-7} \text{ H/m}$

$$X = \omega L = 2\pi (60) 10.395 \times 10^{-7} \Omega / \text{m} = 2\pi (60) 10.395 \times 10^{-7} (1609.34) \frac{\Omega}{\text{mi}} \\ = 0.6307 \Omega / \text{mi} \leftarrow$$

**4.25** Resistance per phase =  $\frac{0.12}{4} = 0.03 \Omega / \text{mi}$

$$\text{GMD} = [(41.76)(80)(41.76)]^{1/3}, \text{ using } \sqrt{40^2 + 12^2} = 41.76. \\ = 51.78 \text{ ft.}$$

GMR for the bundle :  $1.091 \left[ (0.0403)(1.667)^3 \right]^{1/4}$  by Eq. (4.6.21)

[Note: from Table A.4, conductor diameter. = 1.196 in.;  $r = \frac{1.196}{2} \times \frac{1}{12} = 0.0498$  ft.] and

conductor GMR = 0.0403 ft.

GMR for the 4-conductor bundle = 0.7171 ft

$$\therefore X = 0.2794 \log \left( \frac{51.87}{0.7171} \right) = 0.5195 \Omega / \text{mi} \leftarrow$$

Rated current carrying capacity for each conductor in the bundle, as per Table A.4, is 1010 A; since it is a 4-conductor bundle, rated current carrying capacity of the overhead line is

$$1010 \times 4 = 4040 \text{ A} \leftarrow$$

**4.26** Bundle radius A is calculated by

$$0.4572 = 2 A \sin(\pi/8) \text{ or } A = 0.5974 \text{ m}$$

$$\text{GMD} = 17 \text{ m}$$

Subconductor's GMR is  $r' = 0.7788 \left( \frac{4.572}{2} \times 10^{-2} \right) = 1.7803 \times 10^{-2} \text{ m}$

$$L = 2 \times 10^{-7} \ln \frac{\text{GMD}}{[Nr'(A)^{N-1}]^{1/N}} = 2 \times 10^{-7} \ln \left\{ \frac{17}{\left[ 8(1.7803 \times 10^{-2})(0.5974)^7 \right]^{1/8}} \right\}$$

which yields  $L = 7.03 \times 10^{-7} \text{ H/m} \leftarrow$

**4.27** (a)  $D_{AB_{eq}} = [30 \times 30 \times 60 \times 120]^{1/4} = 50.45 \text{ ft}$

$$D_{BC_{eq}} = [30 \times 30 \times 60 \times 120]^{1/4} = 50.45 \text{ ft}$$

$$D_{AC_{eq}} = [60 \times 60 \times 150 \times 30]^{1/4} = 63.44 \text{ ft}$$

$$\therefore \text{GMD} = (50.45 \times 50.45 \times 63.44)^{1/3} = 54.46 \text{ ft}$$

$$\text{Equivalent GMR} = [(0.0588)^3 (90)^3]^{1/6} = 2.3 \text{ ft}$$

$$\therefore L = 2 \times 10^{-7} \ln \left( \frac{54.46}{2.3} \right) = 0.633 \times 10^{-6} \text{ H/m} \leftarrow$$

(b) Inductance of one circuit is calculated below:

$$D_{eq} = [30 \times 30 \times 60]^{1/3} = 37.8 \text{ ft}; \quad r' = 0.0588 \text{ ft}$$

$$\therefore L = 2 \times 10^{-7} \ln \left( \frac{37.8}{0.0588} \right) = 1.293 \times 10^{-6} \text{ H/m}$$

$$\text{Inductance of the double circuit} = \frac{1.293 \times 10^{-6}}{2} = 0.646 \times 10^{-6} \text{ H/m} \leftarrow$$

$$\text{Error percent} = \left( \frac{0.633 - 0.646}{0.633} \right) \times 100 = -2.05\% \leftarrow$$

**4.28** With  $N = 3$ ,  $S = 21''$ ,  $A = \frac{S}{2 \sin 60^\circ} = \frac{21/12}{2 \times 0.866} = 1.0104 \text{ ft}$

Conductor  $GMR = 0.0485 \text{ ft}$

$$\text{Bundle } GMR = \left[ 3(0.0485)(1.0104)^2 \right]^{1/3} = 0.5296 \text{ ft}$$

$$\text{Then } r'_A = \left[ (GMR_b)(D_{AA'}) \right]^{1/2} = \left( 0.5296 \times \sqrt{32^2 + 36^2} \right)^{1/2} = 5.05 \text{ ft}$$

$$r'_B = (GMR_b \cdot D_{BB'})^{1/2} = (0.5296 \times 96)^{1/2} = 7.13 \text{ ft}$$

$$r'_C = (GMR_b \cdot D_{CC'})^{1/2} = \left[ 0.5296 \times \sqrt{32^2 + 36^2} \right]^{1/2} = 5.05 \text{ ft}$$

$$\text{Overall Phase } GMR = (r'_A r'_B r'_C)^{1/3} = 5.67 \text{ ft}$$

$$D_{AB_{eq}} = \left[ \sqrt{32^2 + 36^2} \cdot \sqrt{64^2 + 36^2} \cdot (64)(32) \right]^{1/4} = 51.88 \text{ ft}$$

$$D_{BC_{eq}} = \left[ (32)\sqrt{64^2 + 36^2} \cdot 64 \cdot \sqrt{32^2 + 36^2} \right]^{1/4} = 51.88 \text{ ft}$$

$$D_{AC_{eq}} = \left[ (36)(32)(36)(32) \right]^{1/4} = 33.94 \text{ ft}$$

$$\therefore GMD = \left[ 51.88 \times 51.88 \times 33.94 \right]^{1/3} = 45.04 \text{ ft}$$

$$\text{Then } X_L = 0.2794 \log \left( \frac{45.04}{5.67} \right) = 0.2515 \Omega / \text{mi/phase} \leftarrow$$

**4.29**  $r'_A = \left[ 0.5296(32) \right]^{1/2} = 4.117 \text{ ft}$

$$r'_B = \left[ 0.5296(32) \right]^{1/2} = 4.117 \text{ ft}$$

$$r'_C = \left[ 0.5296(32) \right]^{1/2} = 4.117 \text{ ft}$$

Then  $GMR_{phase} = 4.117 \text{ ft}$

$$D_{AB_{eq}} = \left[ \left\{ (36)^2 + (32)^2 \right\} 36 \cdot \sqrt{64^2 + 36^2} \right]^{1/4} = 49.76 \text{ ft}$$

$$D_{BC_{eq}} = \left[ (64)(96)(32)(64) \right]^{1/4} = 59.56 \text{ ft}$$

$$D_{AC_{eq}} = \left[ \left\{ (32)^2 + (36)^2 \right\} \sqrt{36^2 + 64^2} \cdot (36) \right]^{1/4} = 49.76 \text{ ft}$$

Then  $GMD = (49.76 \times 59.56 \times 49.76)^{1/3} = 52.83 \text{ ft}$

$$X_L = 0.2794 \log \left( \frac{52.83}{4.117} \right) = 0.3097 \Omega / \text{mi/phase} \leftarrow$$

**4.30**  $r'_A = [0.5296(96)]^{1/2} = 7.13 \text{ ft}$

$$r'_B = [0.5296(32)]^{1/2} = 4.117 \text{ ft} = r'_C$$

From which  $GMR_{\text{phase}} = (7.13 \times 4.117 \times 4.117)^{1/3} = 4.95 \text{ ft}$

$$D_{ABeq} = (32 \times 64 \times 32 \times 64)^{1/4} = 45.25 \text{ ft}$$

$$D_{BCeq} = \left[ (36) \left\{ (32)^2 + (36)^2 \right\} (36) \right]^{1/4} = 41.64 \text{ ft}$$

$$D_{ACeq} = \left[ (32^2 + 36)^2 \sqrt{64^2 + 36^2} \right]^{1/4} = 59.47 \text{ ft}$$

Then  $GMD = (45.25 \times 41.64 \times 59.47)^{1/3} = 48.21 \text{ ft}$

$$X_L = 0.2794 \log \left( \frac{48.21}{4.95} \right) = 0.2762 \Omega / \text{mi/ph.} \leftarrow$$

**4.31** Flux linkage between conductors 1 & 2 due to current,  $I_a$ , is

$$\bar{\lambda}_{12(I_a)} = 0.2 \bar{I}_a \ln \frac{D_{a2}}{D_{a1}} \text{ mWb/km}$$

$\therefore D_{b1} = D_{b2}$ ,  $\lambda_{12}$  due to  $I_b$  is zero.

$$\bar{\lambda}_{12(I_c)} = 0.2 \bar{I}_c \ln \frac{D_{c2}}{D_{c1}} \text{ mWb/km}$$

Total flux linkages between conductors 1 & 2 due to all currents is

$$\bar{\lambda}_{12} = 0.2 \bar{I}_a \ln \frac{D_{a2}}{D_{a1}} + 0.2 \bar{I}_c \ln \frac{D_{c2}}{D_{c1}} \text{ mWb/km}$$

For positive sequence, with  $\bar{I}_a$  as reference,  $\bar{I}_c = I_a \angle -240^\circ$

$$\begin{aligned} \therefore \bar{\lambda}_{12} &= 0.2 I_a \left( \ln \frac{D_{a2}}{D_{a1}} + (1 \angle -240^\circ) \ln \frac{D_{c2}}{D_{c1}} \right) \\ &= 0.2 (250) \left[ \ln(7.21/6.4) + (1 \angle -240^\circ) \ln(6.4/7.21) \right] \\ &= 10.31 \angle -30^\circ \text{ mWb/km} \end{aligned}$$

$$\left[ \begin{array}{l} \text{Note: } D_{a1} = D_{c2} = \sqrt{4^2 + 5^2} = 6.4 \text{ m} \\ D_{a2} = D_{c1} = \left[ (5.2)^2 + (5)^2 \right]^{1/2} = 7.21 \text{ m} \end{array} \right]$$

with  $\bar{I}_a$  as reference, instantaneous flux linkage is

$$\lambda_{12}(t) = \sqrt{2} \lambda_{12} \cos(\omega t + \alpha)$$

$\therefore$  Induced voltage in the telephone line per km is

$$\begin{aligned} \bar{V}_{RMS} &= \omega \lambda_{12} \angle \alpha + 90^\circ = j\omega \bar{\lambda}_{12} = j(2\pi \times 60)(10.31 \angle -30^\circ) 10^{-3} \\ &= 3.89 \angle 60^\circ \text{ V} \leftarrow \end{aligned}$$

$$4.32 \quad C_n = \frac{2\pi\epsilon_0}{\text{Ln}\left(\frac{D}{\Gamma}\right)} = \frac{2\pi(8.854 \times 10^{-12})}{\text{Ln}\left(\frac{0.5}{0.015/2}\right)} = \underline{\underline{1.3246 \times 10^{-11} \frac{\text{F}}{\text{m}}}} \text{ to neutral}$$

$$\bar{Y}_n = j\omega C_n = j(2\pi 60)(1.3246 \times 10^{-11}) \frac{\text{S}}{\text{m}} \times 1000 \frac{\text{m}}{\text{km}}$$

$$\bar{Y}_n = \underline{\underline{j4.994 \times 10^{-6} \frac{\text{S}}{\text{km}}}} \text{ to neutral}$$

$$4.33 \quad (a) \quad C_n = \frac{2\pi(8.854 \times 10^{-12})}{\ln\left(\frac{0.5}{0.018/2}\right)} = 1.385 \times 10^{-11} \text{ F/m to neutral}$$

$$\bar{Y}_n = j2\pi(60)1.385 \times 10^{-11}(1000) = j5.221 \times 10^{-6} \text{ S/km to neutral}$$

$$(b) \quad C_n = \frac{2\pi(8.854 \times 10^{-12})}{\ln\left(\frac{0.5}{0.012/2}\right)} = 1.258 \times 10^{-11} \text{ F/m to neutral}$$

$$\bar{Y}_n = j2\pi(60)1.258 \times 10^{-11}(1000) = j4.742 \times 10^{-6} \text{ S/km to neutral}$$

Both the capacitance and admittance-to-neutral increase 4.5% (decrease 5.1%) as the conductor diameter increases 20% (decreases 20%).

$$4.34 \quad C_1 = \frac{2\pi\epsilon_0}{\text{Ln}\left(\frac{D}{\Gamma}\right)} = \frac{2\pi(8.854 \times 10^{-12})}{\text{Ln}\left(\frac{4}{0.25/12}\right)} = \underline{\underline{1.058 \times 10^{-11} \frac{\text{F}}{\text{m}}}}$$

$$\bar{Y}_1 = j\omega C_1 = j(2\pi 60)(1.058 \times 10^{-11})(1000)$$

$$= \underline{\underline{j3.989 \times 10^{-6} \frac{\text{S}}{\text{km}}}}$$

$$4.35 \quad (a) \quad C_1 = \frac{2\pi(8.854 \times 10^{-12})}{\ln\left(\frac{4.8}{0.25/12}\right)} = 1.023 \times 10^{-11} \text{ F/m}$$

$$\bar{Y}_1 = j2\pi(60)1.023 \times 10^{-11}(1000) = j3.857 \times 10^{-6} \text{ S/km}$$

$$(b) C_1 = \frac{2\pi(8.854 \times 10^{-12})}{\ln\left(\frac{3.2}{0.25/12}\right)} = 1.105 \times 10^{-11} \text{ F/m}$$

$$\bar{Y}_1 = j2\pi(60)1.105 \times 10^{-11} (1000) = j4.167 \times 10^{-6} \text{ S/km}$$

The positive sequence shunt capacitance and shunt admittance both decrease 3.3% (increase 4.5%) as the phase spacing increases by 20% (decreases by 20%)

**4.36** (a) Equations (4.10.4) and (4.10.5) apply.

$$\text{For a 2-conductor bundle, the GMR } D_{sc} = \sqrt{rd} = \sqrt{0.0074 \times 0.3} \\ = 0.0471$$

$$\text{The GMD is given by } D_{eq} = \sqrt[3]{6 \times 6 \times 12} = 7.56 \text{ m}$$

Hence the line-to-neutral capacitance is given by

$$C_{an} = \frac{2\pi\epsilon}{\ln(D_{eq}/D_{sc})} \text{ F/m}$$

$$\text{or } \frac{55.63}{\ln(7.56/0.0471)} = 10.95 \text{ nF/km}$$

(with  $\epsilon = \epsilon_0$ )

$$\text{or } 1.609 \times 10.95 = 17.62 \text{ nF/mi}$$

(b) The capacitive reactance at 60HZ is calculated as

$$X_c = \frac{1}{2\pi(60)C_{an}} = 29.63 \times 10^3 \ln \frac{D_{eq}}{D_{sc}} \Omega - \text{mi} \\ = 29.63 \times 10^3 \ln \frac{7.56}{0.0471} = 150,500 \Omega - \text{mi}$$

$$\text{or } 150,500 \times 1.609 = 242,154 \Omega - \text{km}$$

(c) With the line length of 100 mi, the capacitive reactance is found as

$$\frac{150,500}{100} = 1505 \Omega / \text{Phase}$$



**4.37** (a) Eq (4.9.15): capacitance to neutral =  $\frac{2\pi\epsilon}{\ln(D/r)}$  F/m

$$X_c = \frac{1}{2\pi fC} = \frac{\ln(D/r)}{(2\pi f)(2\pi\epsilon)} \Omega \cdot \text{m to neutral}$$

with  $f = 60\text{HZ}$ ,  $\epsilon = 8.854 \times 10^{-12}$  F/m .

or  $X_c = k' \log(D/r)$ , where  $k' = \frac{4.1 \times 10^6}{f}, \Omega \cdot \text{mile to neutral} \leftarrow$

$$= k' \log D + k' \log\left(\frac{1}{r}\right), \quad \text{where } k' = 0.06833 \times 10^6 \quad \text{at } f = 60\text{HZ} .$$

(b)  $X'_d = k' \log D = 0.06833 \times 10^6 \log(10) = 68.33 \times 10^3$

$$X'_a = k' \log\left(\frac{1}{r}\right) = 0.06833 \times 10^6 \log \frac{1}{0.06677} = 80.32 \times 10^3$$

$\therefore X_c = X'_d + X'_a = 148.65 \times 10^3 \Omega \cdot \text{mi to neutral} \leftarrow$

When spacing is doubled,  $X'_d = 0.06833 \times 10^6 \log(20)$   
 $= 88.9 \times 10^3$

Then  $X_c = 169.12 \times 10^3 \Omega \cdot \text{mi to neutral} \leftarrow$

**4.38**  $C = 0.0389 / \log\left(\frac{52.95/12}{0.721/(12 \times 2)}\right) = 0.018 \mu\text{F/mi/ph} .$

$$X_c = \frac{1}{2\pi(60)0.018 \times 10^{-6}} = 147.366 \times 10^3 \Omega \cdot \text{mi} \leftarrow$$

**4.39**  $D_{eq} = \sqrt[3]{8 \times 8 \times 16} = 10.079 \text{ m}$

For Table A.4,  $r = \frac{1.196}{2} \text{in} \left(\frac{0.0254 \text{ m}}{1 \text{ in}}\right) = 0.01519 \text{ m}$

$$C_1 = \frac{2\pi\epsilon_0}{\ln\left(\frac{D}{r}\right)} = \frac{2\pi(8.854 \times 10^{-12})}{\ln\left(\frac{10.079}{0.01519}\right)} = 8.565 \times 10^{-12} \text{ F/m}$$

$$\bar{Y}_1 = j\omega C_1 = j2\pi(60)8.565 \times 10^{-12} (1000) = j3.229 \times 10^{-6} \text{ S/km}$$

For a 100 km line length

$$I_{chg} = Y_1 V_{LN} = (3.229 \times 10^{-6} \times 100) \left(230 / \sqrt{3}\right) = 4.288 \times 10^{-12} \text{ kA/Phase}$$

**4.40** (a)  $D_{eq} = \sqrt[3]{8.8 \times 8.8 \times 17.6} = 11.084 \text{ m}$

$$C_1 = \frac{2\pi(8.854 \times 10^{-12})}{\ln\left(\frac{11.084}{0.01519}\right)} = 8.442 \times 10^{-12} \text{ F/m}$$

$$\bar{Y}_1 = j2\pi(60)8.442 \times 10^{-12}(1000) = j3.183 \times 10^{-6} \text{ S/km}$$

$$I_{chg} = 3.183 \times 10^{-6} \times 1000(230/\sqrt{3}) = 4.223 \times 10^{-12} \frac{\text{kA}}{\text{Phase}}$$

(b)  $D_{eq} = \sqrt[3]{7.2 \times 7.2 \times 14.4} = 9.069 \text{ m}$

$$C_1 = \frac{2\pi(8.854 \times 10^{-12})}{\ln\left(\frac{9.069}{0.01519}\right)} = 8.707 \times 10^{-12} \text{ F/m}$$

$$\bar{Y}_1 = j2\pi(60)8.707 \times 10^{-12}(1000) = j3.284 \times 10^{-6} \text{ S/km}$$

$$I_{chg} = 3.284 \times 10^{-6} \times 100(230/\sqrt{3}) = 4.361 \times 10^{-2} \frac{\text{kA}}{\text{Phase}}$$

$C_1$ ,  $Y_1$ , and  $I_{chg}$  decrease 1.5% (increase 1.7%)

As the phase spacing increases 10% (decreases 10%).

**4.41**  $D_{eq} = \sqrt[3]{10 \times 10 \times 20} = 12.6 \text{ m}$

From Table A.4,  $r = \frac{1.293}{2} \ln\left(\frac{0.0254 \text{ m}}{1 \text{ in}}\right) = 0.01642 \text{ m}$

$$D_{sc} = \sqrt[3]{rd^2} = \sqrt[3]{0.01642(0.5)^2} = 0.16 \text{ m}$$

$$C_1 = \frac{2\pi\epsilon_0}{\ln\frac{D_{eq}}{D_{sc}}} = \frac{2\pi(8.854 \times 10^{-12})}{\ln\left(\frac{12.6}{0.16}\right)} = 1.275 \times 10^{-11} \text{ F/m}$$

$$\bar{Y}_1 = j\omega C_1 = j2\pi(60)1.275 \times 10^{-11}(1000) = j4.807 \times 10^{-6} \text{ S/km}$$

$$Q_1 = V_{LL}^2 Y_1 = (500)^2 4.807 \times 10^{-6} = 1.2 \text{ MVAR/km}$$

**4.42** (a) From Table A.4,  $r = \frac{1.424}{2}(0.0254) = 0.0181 \text{ m}$

$$D_{sc} = \sqrt[3]{0.0181(0.5)^2} = 0.1654 \text{ m}$$

$$C_1 = \frac{2\pi(8.854 \times 10^{-12})}{\ln\left(\frac{12.6}{0.1654}\right)} = 1.284 \times 10^{-11} \text{ F/m}$$

$$\bar{Y}_1 = j2\pi(60)(1.284 \times 10^{-11})(1000) = j4.842 \times 10^{-6} \text{ S/km}$$

$$Q_1 = (500)^2 4.842 \times 10^{-6} = 1.21 \text{ MVAR/km}$$

$$(b) \quad r = \frac{1.162}{2}(0.0254) = 0.01476 \text{ m}; \quad D_{sc} = \sqrt[3]{0.01476(0.5)^2} = 0.1546 \text{ m}$$

$$C_1 = \frac{2\pi(8.854 \times 10^{-12})}{\ln\left(\frac{12.6}{0.1546}\right)} = 1.265 \times 10^{-11} \text{ F/m}$$

$$\bar{Y}_1 = j2\pi(60)1.265 \times 10^{-11}(1000) = 4.77 \times 10^{-6} \text{ S/km}$$

$$Q_1 = (500)^2 4.77 \times 10^{-6} = 1.192 \text{ MVAR/km}$$

$C_1, Y_1,$  and  $Q_1$  increase 0.8% (decrease 0.7%)

For the larger, 1351 kcmil conductors (smallest, 700 kcmil conductors).

**4.43** (a) For drake, Table A.4 lists the outside diameter as 1.108 in

$$\therefore r = \frac{1.108}{2 \times 12} = 0.0462 \text{ ft}$$

$$D_{eq} = \sqrt[3]{20 \times 20 \times 38} = 24.8 \text{ ft}$$

$$C_{an} = \frac{2\pi \times 8.85 \times 10^{-12}}{\ln(24.8/0.0462)} = 8.8466 \times 10^{-12} \text{ F/m}$$

$$X_C = \frac{10^{12}}{2\pi(60)8.8466 \times 1609} = 0.1864 \times 10^6 \Omega \cdot \text{mi}$$

(b) For a length of 175 mi

$$\text{Capacitive reactance} = \frac{0.1864 \times 10^6}{175} = 1065 \Omega \text{ to neutral}$$

$$I_{chg} = \frac{220 \times 10^3}{\sqrt{3}} \frac{1}{X_C} = \frac{0.22}{\sqrt{3} \times 0.1864} = 0.681 \text{ A/mi}$$

$$\text{or} \quad 0.681 \times 175 = 119 \text{ A for the line}$$

Total three-phase reactive power supplied by the capacitance is given by

$$\sqrt{3} \times 220 \times 119 \times 10^{-3} = 43.5 \text{ MVAR}$$

$$\mathbf{4.44} \quad C = 0.0389 / \log\left(\frac{51.87}{0.7561}\right) = 0.0212 \mu\text{F/mi/ph}$$

$$\left[ \text{Note: Equivalent radius of a 4-cond. bundle is given by} \right. \\ \left. 1.091(0.0498d^3)^{1/4} = 1.091(0.0498 \times 1.667^3)^{1/4} = 0.7561 \text{ ft} \right]$$

$$X_C = \frac{1}{2\pi(60)0.0212 \times 10^{-6}} = 125.122 \times 10^3 \Omega \cdot \text{mi} \quad \leftarrow$$

4.45

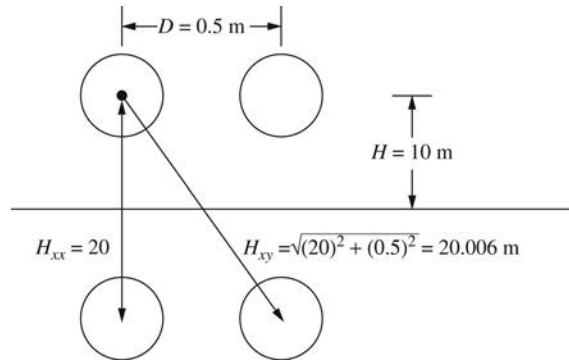

From Example 4.8,

$$C_{xn} = \frac{2\pi\epsilon_0}{\ln\left(\frac{D}{\Gamma}\right) - \ln\left(\frac{HXY}{HXX}\right)} = \frac{2\pi(8.854 \times 10^{-12})}{\ln\left(\frac{0.5}{0.0075}\right) - \ln\left(\frac{20.006}{20}\right)}$$

$$C_{xn} = \underline{\underline{1.3247 \times 10^{-11} \frac{F}{m}}} \text{ which is 0.01\% larger than in Problem 4.32}$$

4.46 (a)  $D_{eq} = \sqrt[3]{12 \times 12 \times 24} = 15.12 \text{ m}$

$$r = 0.0328 / 2 = 0.0164 \text{ m}$$

$$X_c = \frac{1}{2\pi f C_{an}}$$

Where  $C_{an} = \frac{2\pi \times 8.85 \times 10^{-12}}{\ln(15.12 / 0.0164)}$

$$\therefore X_c = \frac{2.86}{60} \times 10^9 \ln \frac{15.12}{0.0164} = 3.254 \times 10^8 \Omega \cdot \text{m}$$

For 125 km,  $X_c = \frac{3.254 \times 10^8}{125 \times 1000} = 2603 \Omega$

(b)

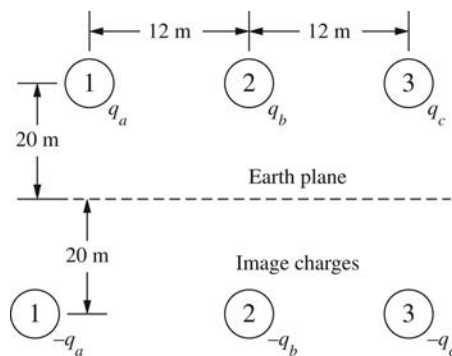

$$H_1 = H_2 = H_3 = 40 \text{ m}$$

$$H_{12} = H_{23} = \sqrt{40^2 + 12^2} = 41.761 \text{ m}$$

$$H_{31} = \sqrt{40^2 + 24^2} = 46.648 \text{ m}$$

$$D_{eq} = 15.12 \text{ m} \quad \text{and} \quad r = 0.0164 \text{ m}$$

$$\begin{aligned} \therefore X_C &= \frac{2.86}{60} \times 10^9 \left[ \ln \frac{D_{eq}}{r} - \frac{1}{3} \ln \frac{H_{12} H_{23} H_{31}}{H_1 H_2 H_3} \right] \Omega \cdot \text{m} \\ &= 4.77 \times 10^7 \left[ \ln \frac{15.12}{0.0164} - \frac{1}{3} \ln \frac{41.761 \times 41.761 \times 46.648}{40 \times 40 \times 40} \right] \\ &= 3.218 \times 10^8 \Omega \cdot \text{m} \end{aligned}$$

$$\text{For } 125 \text{ km, } X_C = \frac{3.218 \times 10^8}{125 \times 10^3} = 2574 \Omega$$

$$\begin{aligned} \mathbf{4.47} \quad D &= 10 \text{ ft; } r = 0.06677 \text{ ft; } H_{xx} = 160 \text{ ft.; } H_{xy} = \sqrt{160^2 + 10^2} \\ &= 160.3 \text{ ft} \end{aligned}$$

(See Fig. 4.24 of text)

$$\text{Line-to-line capacitance } C_{xy} = \frac{\pi \epsilon}{\ln \frac{D}{r} - \ln \frac{H_{xy}}{H_{xx}}} \text{ F/m}$$

(See Ex. 4.8 of the text)

$$C_{xy} = \frac{\pi (8.854 \times 10^{-12})}{\ln \left( \frac{10}{0.06677} \right) - \ln \left( \frac{160.3}{160} \right)} = 5.555 \times 10^{-12} \text{ F/m}$$

$$\begin{aligned} \text{Neglecting Earth effect, } C_{xy} &= \frac{\pi (8.854 \times 10^{-12})}{\ln \left( \frac{10}{0.06677} \right)} \\ &= 5.553 \times 10^{-12} \text{ F/m} \end{aligned}$$

$$\text{Error - percentage} = \frac{5.555 - 5.553}{5.555} \times 100 = 0.036\%$$

When the phase separation is doubled,  $D = 20 \text{ ft}$

$$H_{xy} = \sqrt{160^2 + 20^2} = 161.245$$

$$\begin{aligned} \text{With effect of Earth, } C_{xy} &= \frac{\pi (8.854 \times 10^{-12})}{\ln \left( \frac{20}{0.06677} \right) - \ln \left( \frac{161.245}{160} \right)} \\ &= 4.885 \times 10^{-12} \text{ F/m} \end{aligned}$$

$$\begin{aligned} \text{Neglecting Earth effect, } C_{xy} &= \frac{\pi(8.854 \times 10^{-12})}{\ln\left(\frac{20}{0.06677}\right)} \\ &= 4.878 \times 10^{-12} \text{ F/m} \\ \text{Error percentage} &= \frac{4.885 - 4.878}{4.885} \times 100 = 0.143\% \end{aligned}$$

**4.48** (a)  $H_1 = H_2 = H_3 = 2 \times 50 = 100 \text{ ft}$

$$H_{12} = H_{23} = \sqrt{25^2 + 100^2} = 103.08 \text{ ft}$$

$$H_{13} = \sqrt{50^2 + 100^2} = 111.8 \text{ ft}$$

$$D_{eq} = \sqrt[3]{(25)(25)(50)} = 31.5 \text{ ft}$$

$$r = \frac{1.065}{2 \times 12} = 0.0444 \text{ ft}$$

$$C_{an} = \frac{2\pi(8.854 \times 10^{-12})}{\ln\left(\frac{31.5}{0.0444}\right) - \ln\left(\frac{106}{100}\right)} = 9.7695 \times 10^{-12} \text{ F/m} \leftarrow$$

$$\left[ \begin{array}{l} \text{Note : } H_m = (103.08 \times 103.08 \times 111.8)^{1/3} = 106 \text{ ft} \\ H_s = 100 \text{ ft} \end{array} \right]$$

(b) Neglecting the effect of ground,

$$C_{an} = \frac{2\pi(8.854 \times 10^{-12})}{\ln\left(\frac{31.5}{0.0444}\right)} = 8.4746 \times 10^{-12} \text{ F/m}$$

Effect of ground gives a higher value.

$$\text{Error percent} = \frac{9.7695 - 8.4746}{9.7695} \times 100 = 13.25\%$$

**4.49**  $GMD = (60 \times 60 \times 120)^{1/3} = 75.6 \text{ ft}$

$$r = \frac{1.16}{2 \times 12} = 0.0483 \text{ ft}; N = 4; S = 2A \sin \frac{\pi}{N}$$

or  $A = \frac{18}{(2 \sin 45^\circ)12} = 1.0608 \text{ ft}$

$$GMR = \left[ rN(A)^{N-1} \right]^{1/N} = \left[ 0.0483 \times 4 \times (1.0608)^3 \right]^{1/4}$$

$$= 0.693 \text{ ft}$$

$$\therefore C_{an} = \frac{2\pi(8.854 \times 10^{-12})}{\ln\left(\frac{75.6}{0.693}\right)} = 11.856 \times 10^{-12} \text{ F/m} \leftarrow$$

$$\text{Next } X'_d = 0.0683 \log(75.6) = 0.1283$$

$$X'_a = 0.0683 \log\left(\frac{1}{0.693}\right) = 0.0109$$

$$X_c = X'_a + X'_d = 0.1392 \text{ M}\Omega \cdot \text{mi to neutral}$$

$$= 0.1392 \times 10^6 \Omega \cdot \text{mi to neutral} \leftarrow$$

**4.50** From Problem 4.45

$$C_{xy} = \frac{1}{2} C_{xm} = \frac{1}{2} (1.3247 \times 10^{-11}) = 6.6235 \times 10^{-12} \frac{\text{F}}{\text{m}}$$

$$\text{with } V_{xy} = 20 \text{ kV}$$

$$Q_x = C_{xy} V_{xy} = (6.6235 \times 10^{-12})(20 \times 10^3) = 1.3247 \times 10^{-7} \frac{\text{C}}{\text{m}}$$

From Eq (4.12.1) The conductor surface electric field strength is:

$$E_T = \frac{1.3247 \times 10^{-7}}{(2\pi)(8.854 \times 10^{-12})(0.0075)}$$

$$= 3.1750 \times 10^5 \frac{\text{V}}{\text{m}} \times \left( \frac{\text{kV}}{1000 \text{ V}} \right) \left( \frac{\text{m}}{100 \text{ cm}} \right)$$

$$= \underline{\underline{3.175}} \frac{\text{kV}_{\text{rms}}}{\text{cm}}$$

Using Eq (4.12.6), the ground level electric field strength directly under the conductor is:

$$E_k = \frac{1.3247 \times 10^{-7}}{(2\pi)(8.854 \times 10^{-12})} \left[ \frac{(2)(10)}{(10)^2} - \frac{(2)(10)}{(10)^2 + (0.5)^2} \right]$$

$$= 1.188 \frac{\text{V}}{\text{m}} \times \left( \frac{\text{kV}}{1000 \text{ V}} \right) = \underline{\underline{0.001188}} \frac{\text{kV}}{\text{m}}$$

4.51 (a) From Problem 4.30,

$$C_{xn} = \frac{2\pi(8.854 \times 10^{-12})}{\ln\left(\frac{0.5}{0.009375}\right) - \ln\left(\frac{20.006}{20}\right)} = 1.3991 \times 10^{-11} \frac{\text{F}}{\text{m}}$$

$$C_{xy} = \frac{1}{2}C_{xn} = 6.995 \times 10^{-12} \frac{\text{F}}{\text{m}}$$

$$Q_x = C_{xy} V_{xy} = (6.995 \times 10^{-12})(20 \times 10^3) = 1.399 \times 10^{-7} \frac{\text{C}}{\text{m}}$$

$$E_{\Gamma} = \frac{1.399 \times 10^{-7}}{(2\pi)(8.854 \times 10^{-12})(0.009375)} \times \left(\frac{1}{1000}\right) \left(\frac{1}{100}\right)$$

$$= \underline{\underline{2.682}} \frac{\text{kV}_{\text{rms}}}{\text{cm}}$$

$$E_k = \frac{1.399 \times 10^{-7}}{(2\pi)(8.854 \times 10^{-12})} \left[ \frac{(2)(10)}{(10)^2} - \frac{(2)(10)}{(10)^2 + (0.5)^2} \right]$$

$$= 1.254 \frac{\text{V}}{\text{m}} \times \left(\frac{\text{kV}}{1000 \text{ V}}\right) = \underline{\underline{0.001254}} \frac{\text{kV}}{\text{m}}$$

$$(b) C_{xn} = \frac{2\pi(8.854 \times 10^{-12})}{\ln\left(\frac{0.5}{.005625}\right) - \ln\left(\frac{20.06}{20}\right)} = 1.2398 \times 10^{-11} \frac{\text{F}}{\text{m}}$$

$$C_{xy} = \frac{1}{2}C_{xn} = 6.199 \times 10^{-12} \frac{\text{F}}{\text{m}}$$

$$Q_x = C_{xy} V_{xy} = (6.199 \times 10^{-12})(20 \times 10^3) = 1.2398 \times 10^{-7} \frac{\text{C}}{\text{m}}$$

$$E_{\Gamma} = \frac{1.2398 \times 10^{-7}}{(2\pi)(8.854 \times 10^{-12})(.005625)} \times \left(\frac{1}{1000}\right) \left(\frac{1}{100}\right)$$

$$E_{\Gamma} = \underline{\underline{3.962}} \frac{\text{kV}_{\text{rms}}}{\text{cm}}$$

$$E_k = \frac{1.2398 \times 10^{-7}}{(2\pi)(8.854 \times 10^{-12})} \left[ \frac{(2)(10)}{(10)^2} - \frac{(2)(10)}{(10)^2 + (0.5)^2} \right]$$

$$E_k = 1.112 \frac{\text{V}}{\text{m}} \times \left(\frac{\text{kV}}{1000 \text{ V}}\right) = \underline{\underline{0.001112}} \frac{\text{kV}}{\text{m}}$$

The conductor surface electric field strength  $E_{\Gamma}$  decreases 15.5 % ( increases 24.8%) as the conductor diameter increases 25 % (decreases 25%). The ground level electric field strength  $E_k$  increases 5.6 % ( decreases 6.4%).





# Chapter 5

## Transmission-Lines: Steady-State Operation

### ANSWERS TO MULTIPLE-CHOICE TYPE QUESTIONS

- 5.1 (a)  $\bar{V}_S = A\bar{V}_R + B\bar{I}_R$  (b)  $\bar{I}_S = C\bar{V}_R + D\bar{I}_R$
- 5.2. a
- 5.3  $\bar{V}_{RNL} = \bar{V}_S/A$
- 5.4 Dimensionless, ohms, siemens, dimensionless
- 5.5 Thermal limit; voltage-drop limit; steady-state stability limit
- 5.6 a
- 5.7  $m^{-1}$ , ohms
- 5.8  $(e^{\gamma x} + e^{-\gamma x})/2$ ;  $(e^{\gamma x} - e^{-\gamma x})/2$
- 5.9 a
- 5.10 a
- 5.11 Dimensionless constants (per unit)
- 5.12 a
- 5.13 Real, imaginary
- 5.14 Inductive, capacitive
- 5.15 a
- 5.16 a
- 5.17 Surge impedance
- 5.18 Flat (constant);  $V^2/Z_C$
- 5.19  $V_S V_R / X'$
- 5.20 a
- 5.21 a
- 5.22 a
- 5.23 a
- 5.24 Voltage regulation, loadability
- 5.25 a

5.1 (a)  $\bar{A} = \bar{D} = 1.0 \angle 0^\circ \text{ pu}; \bar{C} = 0. \text{ S}$

$$\bar{B} = \bar{Z} = (0.19 + j0.34) 25 = 9.737 \angle 60.8^\circ \Omega$$

(b)  $\bar{V}_R = \frac{33}{\sqrt{3}} \angle 0^\circ = 19.05 \angle 0^\circ \text{ kV}_{\text{LN}}$

$$\bar{I}_R = \frac{S_R \angle -\cos^{-1}(pf)}{\sqrt{3} V_{R-L-L}} = \frac{10}{\sqrt{3}(33)} \angle -\cos^{-1}(0.9)$$

$$= 0.175 \angle -25.84^\circ \text{ kA}$$

$$\bar{V}_S = \bar{A}\bar{V}_R + \bar{B}\bar{I}_R = (1.0)(19.05) + (9.737 \angle 60.8^\circ)(0.175 \angle -25.84^\circ)$$

$$= 20.45 + j0.976 = 20.47 \angle 2.732^\circ \text{ kV}_{\text{L-N}}$$

$$V_{S_{L-L}} = 20.47\sqrt{3} = 35.45 \text{ kV}$$

(c)  $\bar{I}_R = 0.175 \angle 25.84^\circ$

$$\bar{V}_S = \bar{A}\bar{V}_R + \bar{B}\bar{I}_R = (1.0)(19.05) + (9.737 \angle 60.8^\circ)(0.175 \angle 25.84^\circ)$$

$$= 19.15 + j1.701 = 19.23 \angle 5.076^\circ \text{ kV}_{\text{L-N}}$$

$$V_{S_{L-L}} = 19.23\sqrt{3} = 33.3 \text{ kV}$$

5.2 (a)  $\bar{A} = \bar{D} = 1 + \frac{\bar{Y}\bar{Z}}{2} = 1 + \frac{1}{2}(3.33 \times 10^{-6} \times 200 \angle 90^\circ)(0.08 + j0.48)(200)$

$$= 1 + (0.0324 \angle 170.5^\circ) = 0.968 + j0.00533 = 0.968 \angle 0.315^\circ \text{ pu}$$

$$\bar{C} = \bar{Y} \left( 1 + \frac{\bar{Y}\bar{Z}}{4} \right) = (6.66 \times 10^{-4} \angle 90^\circ)(1 + 0.0162 \angle 170.5^\circ)$$

$$= 6.553 \times 10^{-4} \angle 90.155^\circ \text{ S}$$

$$\bar{B} = \bar{Z} = 97.32 \angle 80.54^\circ \Omega$$

(b)  $\bar{V}_R = \frac{220}{\sqrt{3}} \angle 0^\circ = 127 \angle 0^\circ \text{ kV}_{\text{L-N}}$

$$\bar{I}_R = \frac{P_R \angle -\cos^{-1}(pf)}{\sqrt{3} V_{R-L-L} (pf)} = \frac{250 \angle -\cos^{-1} 0.99}{\sqrt{3}(220)(0.99)} = 0.6627 \angle -8.11^\circ \text{ kA}$$

$$\bar{V}_S = \bar{A}\bar{V}_R + \bar{B}\bar{I}_R = (0.968 \angle 0.315^\circ)(127 \angle 0^\circ) + (97.32 \angle 80.54^\circ)(0.6627 \angle -8.11^\circ)$$

$$= 142.4 + j62.16 = 155.4 \angle 23.58^\circ \text{ kV}_{\text{L-N}}$$

$$\bar{V}_{S_{L-L}} = 155.4\sqrt{3} = 269.2 \text{ kV}$$

$$\bar{I}_S = \bar{C}\bar{V}_R + \bar{D}\bar{I}_R = (6.553 \times 10^{-4} \angle 90.155^\circ)(127) + (0.968 \angle -0.315^\circ)(0.6627 \angle -8.11^\circ)$$

$$= 0.6353 - j3.786 \times 10^{-3} = 0.6353 \angle -0.34^\circ \text{ kA}$$

(c)  $V_{RNL} = V_S / A = 269.2 / 0.968 = 278.1 \text{ kV}_{\text{LL}}$

$$\% VR = \frac{V_{RNL} - V_{RFL}}{V_{RFL}} \times 100 = \left( \frac{278.1 - 220}{220} \right) 100 = 26.4\%$$

$$5.3 \quad Z_{base} = V_{base}^2 / S_{base} = (230)^2 / 100 = 529 \Omega$$

$$Y_{base} = 1 / Z_{base} = 1.89 \times 10^{-3} \text{ S}$$

$$(a) \quad \bar{A} = \bar{D} = 0.9680 \angle 0.315 \text{ pu}$$

$$\bar{B} = (97.32 \angle 80.54^\circ \Omega) / 529 \Omega = 0.184 \angle 80.54^\circ \text{ pu}$$

$$\bar{C} = (6.553 \times 10^{-4} \angle 90.155 \text{ S}) / (1.89 \times 10^{-3} \text{ S}) = 0.3467 \angle 90.155^\circ \text{ pu}$$

$$(b) \quad I_{base} = \frac{S_{base 3\phi}}{\sqrt{3} V_{base L-L}} = \frac{100}{\sqrt{3} (230)} = 0.251 \text{ kA}$$

$$\bar{V}_{Rpu} = (220/230) \angle 0^\circ = 0.9565 \angle 0^\circ$$

$$\bar{I}_{Rpu} = (0.6627 \angle -8.11^\circ) / 0.251 = 2.64 \angle -8.11^\circ$$

$$\bar{V}_{SPU} = \bar{A}_{PU} \bar{V}_{RPU} + \bar{B}_{PU} \bar{I}_{RPU}$$

$$= (0.968 \angle 0.315^\circ)(0.9565 \angle 0^\circ) + (0.184 \angle 80.54^\circ)(2.64 \angle -8.11^\circ)$$

$$= 1.0725 + j0.4682 = 1.17 \angle 23.58^\circ \text{ pu}; \quad V_s = 1.17 \text{ pu}$$

$$\bar{I}_{SPU} = \bar{C}_{PU} \bar{V}_{RPU} + \bar{D}_{PU} \bar{I}_{RPU}$$

$$= (0.3467 \angle 90.155^\circ)(0.9565 \angle 0^\circ) + (0.968 \angle 0.315^\circ)(2.64 \angle -8.11^\circ)$$

$$= 2.531 - j0.0151 = 2.531 \angle -0.34^\circ \text{ pu}; \quad I_s = 2.531 \text{ pu}$$

$$(c) \quad V_{RNLpu} = V_{Spu} / A_{pu} = 1.17 / 0.968 = 1.209$$

$$\%VR = \frac{V_{RNLpu} - V_{RFLpu}}{V_{RFLpu}} \times 100 = \left( \frac{1.209 - 0.9565}{0.9565} \right) 100 = 26.4\%$$

#### 5.4

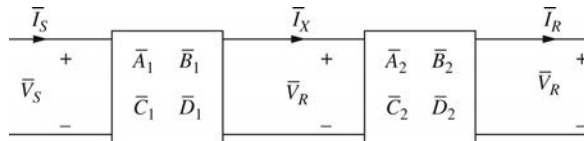

$$\begin{bmatrix} \bar{V}_S \\ \bar{I}_S \end{bmatrix} = \begin{bmatrix} \bar{A}_1 & \bar{B}_1 \\ \bar{C}_1 & \bar{D}_1 \end{bmatrix} \begin{bmatrix} \bar{V}_x \\ \bar{I}_x \end{bmatrix} = \begin{bmatrix} \bar{A}_1 & \bar{B}_1 \\ \bar{C}_1 & \bar{D}_1 \end{bmatrix} \begin{bmatrix} \bar{A}_2 & \bar{B}_2 \\ \bar{C}_2 & \bar{D}_2 \end{bmatrix} \begin{bmatrix} \bar{V}_R \\ \bar{I}_R \end{bmatrix}$$

$$\begin{bmatrix} \bar{V}_S \\ \bar{I}_S \end{bmatrix} = \begin{bmatrix} (\bar{A}_1 \bar{A}_2 + \bar{B}_1 \bar{C}_2) & (\bar{A}_1 \bar{B}_2 + \bar{B}_1 \bar{D}_2) \\ (\bar{C}_1 \bar{A}_2 + \bar{D}_1 \bar{C}_2) & (\bar{C}_1 \bar{B}_2 + \bar{D}_1 \bar{D}_2) \end{bmatrix} \begin{bmatrix} \bar{V}_R \\ \bar{I}_R \end{bmatrix}$$

#### 5.5

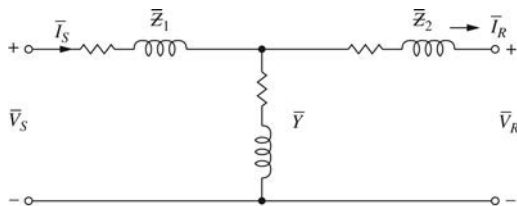

$$KCL: \bar{I}_S = \bar{I}_R + \bar{Y}(\bar{V}_R + \bar{Z}_2 \bar{I}_R) = \bar{Y} \bar{V}_R + (1 + \bar{Y} \bar{Z}_2) \bar{I}_R$$

$$\begin{aligned} KVL: \bar{V}_S &= \bar{V}_R + \bar{Z}_2 \bar{I}_R + \bar{Z}_1 \bar{I}_S \\ &= \bar{V}_R + \bar{Z}_2 \bar{I}_R + \bar{Z}_1 [\bar{Y} \bar{V}_R + (1 + \bar{Y} \bar{Z}_2) \bar{I}_R] \\ &= (1 + \bar{Y} \bar{Z}_1) \bar{V}_R + (\bar{Z}_1 + \bar{Z}_2 + \bar{Y} \bar{Z}_1 \bar{Z}_2) \bar{I}_R \end{aligned}$$

In matrix format:

$$\begin{bmatrix} \bar{V}_S \\ \bar{I}_S \end{bmatrix} = \begin{bmatrix} (1 + \bar{Y} \bar{Z}_1) & | & (\bar{Z}_1 + \bar{Z}_2 + \bar{Y} \bar{Z}_1 \bar{Z}_2) \\ \bar{Y} & | & (1 + \bar{Y} \bar{Z}_2) \end{bmatrix} \begin{bmatrix} \bar{V}_R \\ \bar{I}_R \end{bmatrix}$$

5.6 (a)

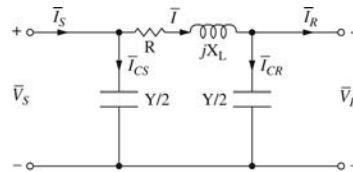

$\bar{V}_R$  is taken as reference;  $\bar{I} = \bar{I}_R + \bar{I}_{CR}$ ;  $\bar{I}_S = \bar{I} + \bar{I}_{CS}$ ;

$\bar{I}_{CR} \perp \bar{V}_R$  (Leading);  $\bar{I}_{CS} \perp \bar{V}_S$  (Leading);  $\bar{V}_R + \bar{I}R + j\bar{I}X_L = \bar{V}_S$

$(\bar{I}R) \parallel \bar{I}$ ;  $(j\bar{I}X_L) \perp \bar{I}$

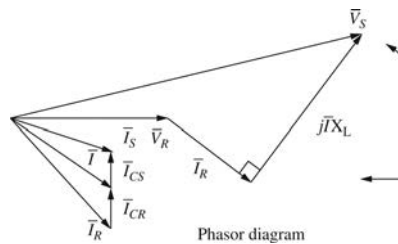

(b)

$$(i) \quad \bar{I}_S = \bar{I}_R + \bar{I}_C; \bar{V}_C = \bar{V}_R + \bar{I}_R \left( \frac{R}{2} + \frac{jX_L}{2} \right); \bar{I}_C \perp \bar{V}_C \text{ (Leading)}$$

$$\bar{V}_S = \bar{V}_C + \bar{I}_S \left( \frac{R}{2} + \frac{jX_L}{2} \right); \bar{V}_R \text{ is taken as reference.}$$

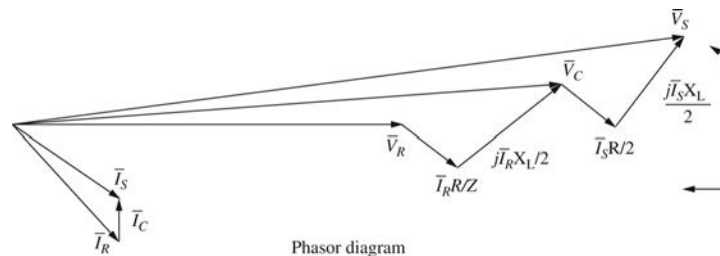

(ii) For nominal T-circuit

$$\bar{A} = 1 + \frac{1}{2} \bar{Y} \bar{Z} = D; \bar{B} = \bar{Z} \left( 1 + \frac{1}{4} \bar{Y} \bar{Z} \right); \bar{C} = \bar{Y} \leftarrow$$

For nominal  $\pi$ -circuit of part (a)

$$\bar{A} = \bar{D} = 1 + \frac{1}{2} \bar{Y} \bar{Z}; \bar{B} = \bar{Z}; \bar{C} = \bar{Y} \left( 1 + \frac{1}{4} \bar{Y} \bar{Z} \right) \leftarrow$$

5.7  $V_s = \frac{3300}{\sqrt{3}} = 1905.3 \text{ V (Line-to-neutral)}$

$$0.5 \angle 53.13^\circ = 0.5(0.6 + j0.8) = 0.3 + j0.4$$

$$I = \frac{(900/3)10^3}{0.8 \times V_R} = \frac{375 \times 10^3}{V_R} \text{ A}$$

From the phasor diagram drawn below with  $\bar{I}$  as reference,

$$V_s^2 = (V_R \cos \phi_R + IR)^2 + (V_R \sin \phi_R + IX)^2 \quad (1)$$

$$(1905.3)^2 = \left( 0.8V_R + \frac{375 \times 10^3 \times 0.3}{V_R} \right)^2 + \left( 0.6V_R + \frac{375 \times 10^3 \times 0.4}{V_R} \right)^2$$

From which one gets  $V_R = 1805 \text{ V}$

(a) Line-to-line voltage at receiving end =  $1805\sqrt{3}$

$$= 3126 \text{ V } \leftarrow$$

$$= 3.126 \text{ kV}$$

(b) Line current is given by

$$I = \frac{375 \times 10^3}{V_R} = 207.76 \text{ A } \leftarrow$$

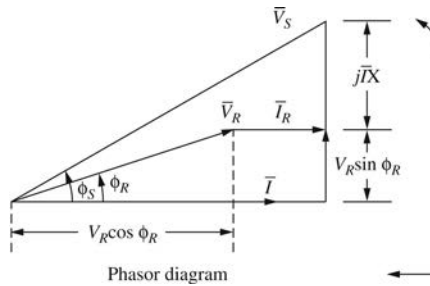

5.8 (a) From phasor diagram of Problem 5.7 solution,

$$V_R \cos \phi_R + IR = 1805(0.8) + (207.76 \times 0.3) = 1506.33 \text{ V}$$

$$\text{Sending-End PF} = \frac{1506.33}{V_s} = \frac{1506.33}{1905.3} = 0.79 \text{ Lagging } \leftarrow$$

$$(b) \text{ Sending-End 3-Phase Power} = P_s = 3(1905.3)(207.76)0.79 \\ = 938 \text{ kW} \leftarrow$$

$$(c) \text{ Three-Phase Line Loss} = 938 - 900 = 38 \text{ kW} \leftarrow \\ \text{or } 3(207.76)^2 0.3 = 38 \text{ kW}$$

$$5.9 \quad (a) \text{ From Table A.4, } R = 0.1128 \frac{\Omega}{\text{mi}} \left( \frac{1 \text{ mi}}{1.609 \text{ km}} \right) = 0.0701 \Omega/\text{km}$$

$$\bar{z} = 0.0701 + j0.506 = 0.511 \angle 82.11^\circ \Omega/\text{km}; \bar{y} = 3.229 \times 10^{-6} \angle 90^\circ \text{ s/km}$$

From Problems 4.14 and 4.25

$$\bar{A} = \bar{D} = 1 + \frac{\bar{Y}\bar{Z}}{2} = 1 + \frac{1}{2}(3.229 \times 10^{-6} \times 100 \angle 90^\circ)(0.511 \times 100 \angle 82.11^\circ) \\ = 0.9918 \angle 0.0999^\circ \text{ per unit}$$

$$\bar{B} = \bar{Z} = \bar{z}l = 0.511 \times 100 \angle 82.11^\circ = 51.1 \angle 82.11^\circ \Omega$$

$$\bar{C} = \bar{Y} \left( 1 + \frac{\bar{Y}\bar{Z}}{4} \right) = (3.229 \times 10^{-4} \angle 90^\circ) [1 + 0.004125 \angle 172.11^\circ] \\ = 3.216 \times 10^{-4} \angle 90.033^\circ \text{ S}$$

$$\bar{V}_R = \frac{218}{\sqrt{3}} \angle 0^\circ = 125.9 \angle 0^\circ \text{ kV}_{\text{LN}}$$

$$\bar{I}_R = \frac{300}{218\sqrt{3}} \angle -\cos^{-1} 0.9 = 0.7945 \angle -25.84^\circ \text{ kA}$$

$$\bar{V}_s = \bar{A}\bar{V}_R + \bar{B}\bar{I}_R = 0.9918 \angle 0.0999^\circ (125.9) + 51.1 \angle 82.11^\circ (0.7945 \angle -25.84^\circ) \\ = 151.3 \angle 12.98^\circ \text{ kV}_{\text{LN}}$$

$$V_s = 151.3\sqrt{3} = 262 \text{ kV}_{\text{LL}}$$

$$V_{RNL} = V_s / A = 262 / 0.9918 = 264.2 \text{ kV}_{\text{LL}}$$

$$\% VR = \frac{V_{RNL} - V_{RFL}}{V_{RFL}} \times 100 = \frac{264.2 - 218}{218} \times 100 = 21.2\%$$

$$(b) \bar{I}_R = 0.7945 \angle 0^\circ \text{ kA}$$

$$\bar{V}_s = 0.9918 \angle 0.0999^\circ (125.9) + 51.1 \angle 82.11^\circ (0.7945 \angle 0^\circ) \\ = 136.6 \angle 17.2^\circ \text{ kV}_{\text{LN}}; V_s = 136.6\sqrt{3} = 236.6 \text{ kV}_{\text{LL}}$$

$$V_{RNL} = V_s / A = 236.6 / 0.9918 = 238.6 \text{ kV}_{\text{LL}}$$

$$\% VR = \frac{238.6 - 218}{218} \times 100 = 9.43\%$$

$$\begin{aligned}
(c) \quad \bar{I}_R &= 0.7945 \angle 25.84^\circ \text{ kA} \\
\bar{V}_S &= 124.9 \angle 0.0999^\circ + 40.6 \angle 107.95^\circ = 118.9 \angle 19.1^\circ \text{ kV}_{\text{LN}} \\
V_S &= 118.9\sqrt{3} = 205.9 \text{ kV}_{\text{LL}} \\
\% VR &= \frac{205.9 - 218}{218} \times 100 = -5.6\%
\end{aligned}$$

**5.10** From Table A.4,  $R = \frac{1}{3}(0.0969) \frac{\Omega}{\text{mi}} \left( \frac{1 \text{ mi}}{1.609 \text{ km}} \right) = 0.0201 \Omega/\text{km}$

From Problems 4.20 and 4.41,  $\bar{z} = 0.0201 + j0.335 = 0.336 \angle 86.6^\circ \Omega/\text{km}$

$$\bar{y} = 4.807 \times 10^{-6} \angle 90^\circ \text{ S/km}$$

$$\begin{aligned}
(a) \quad \bar{A} = \bar{D} &= 1 + \frac{\bar{Y} \bar{Z}}{2} = 1 + \frac{1}{2} (0.336 \times 180 \angle 86.6^\circ) (4.807 \times 10^{-6} \times 180 \angle 90^\circ) \\
&= 0.9739 \angle 0.0912^\circ \text{ pu}
\end{aligned}$$

$$\bar{B} = \bar{Z} = \bar{z}l = 0.336(180) \angle 86.6^\circ = 60.48 \angle 86.6^\circ \Omega$$

$$\begin{aligned}
\bar{C} = \bar{Y} \left( 1 + \frac{\bar{Y} \bar{Z}}{4} \right) &= (4.807 \times 10^{-6} \times 180 \angle 90^\circ) (1 + 0.0131 \angle 176.6^\circ) \\
&= 8.54 \times 10^{-4} \angle 90.05^\circ \text{ S}
\end{aligned}$$

$$(b) \quad \bar{V}_R = \frac{475}{\sqrt{3}} \angle 0^\circ = 274.24 \angle 0^\circ \text{ kV}_{\text{LN}}$$

$$\bar{I}_R = \frac{P_R \angle \cos^{-1}(pf)}{\sqrt{3} V_{RLL} (pf)} = \frac{1600 \angle \cos^{-1} 0.95}{\sqrt{3} 475 (0.95)} = 2.047 \angle 18.19^\circ \text{ kA}$$

$$\begin{aligned}
\bar{V}_S = \bar{A} \bar{V}_R + \bar{B} \bar{I}_R &= (0.9739 \angle 0.0912^\circ) (274.24) + (60.48 \angle 86.6^\circ) (2.047 \angle 18.19^\circ) \\
&= 264.4 \angle 27.02^\circ \text{ kV}_{\text{LN}}; V_S = 264.4\sqrt{3} = 457.9 \text{ kV}_{\text{LL}}
\end{aligned}$$

$$\begin{aligned}
\bar{I}_S = \bar{C} \bar{V}_R + \bar{D} \bar{I}_R &= (8.54 \times 10^{-4} \angle 90.05^\circ) (274.24) + (0.9739 \angle 0.0912^\circ) (2.047 \angle 18.19^\circ) \\
&= 2.079 \angle 24.42^\circ \text{ kA}
\end{aligned}$$

(c) B

(d) Full-load line losses =  $P_S - P_R = 1647 - 1600 = 47 \text{ MW}$

$$\text{Efficiency} = (P_R / P_S) 100 = (1600 / 1647) 100 = 97.1\%$$

(e)  $V_{RNL} = V_S / A = 457.9 / 0.9739 = 470.2 \text{ kV}_{\text{LL}}$

$$\% VR = \frac{V_{RNL} - V_{RFL}}{V_{RFL}} \times 100 = \frac{470.2 - 475}{475} \times 100 = -1\%$$



5.11 (a) The series impedance per phase  $\bar{Z} = (r + j\omega L)l$

$$= (0.15 + j2\pi(60)1.3263 \times 10^{-3})40 = 6 + j20 \Omega$$

The receiving end voltage per phase  $\bar{V}_R = \frac{220}{\sqrt{3}} \angle 0^\circ = 127 \angle 0^\circ \text{ kV}$

Complex power at the receiving end  $\bar{S}_{R(3\phi)} = 381 \angle \cos^{-1} 0.8 \text{ MVA}$   
 $= 304.8 + j228.6 \text{ MVA}$

The current per phase is given by  $\bar{S}_{R(3\phi)}^* / 3\bar{V}_R^*$

$$\therefore \bar{I}_R = \frac{(381 \angle -36.87^\circ)10^3}{3 \times 127 \angle 0^\circ} = 1000 \angle -36.87^\circ \text{ A}$$

The sending end voltage, as per KVL, is given by

$$\bar{V}_S = \bar{V}_R + \bar{Z}\bar{I}_R = 127 \angle 0^\circ + (6 + j20)(1000 \angle -36.87^\circ)10^{-3}$$

$$= 144.33 \angle 4.93^\circ \text{ kV}$$

The sending end line-to-line voltage magnitude is then

$$V_{S(L-L)} = \sqrt{3}(144.33) = 250 \text{ kV}$$

The sending power is  $\bar{S}_{S(3\phi)} = 3\bar{V}_S\bar{I}_S^* = 3(144.33 \angle 4.93^\circ)(1000 \angle 36.87^\circ)10^{-3}$   
 $= 322.8 \text{ MW} + j288.6 \text{ MVAR} = 433 \angle 41.8^\circ \text{ MVA}$

Voltage regulation is  $\frac{250 - 220}{220} = 0.136$

Transmission line efficiency is  $\eta = \frac{P_R(3\phi)}{P_S(3\phi)} = \frac{304.8}{322.8} = 0.944$

(b) With 0.8 leading power factor,  $\bar{I}_R = 1000 \angle 36.87^\circ \text{ A}$

The sending end voltage is  $\bar{V}_S = \bar{V}_R + \bar{Z}\bar{I}_R = 121.39 \angle 9.29^\circ \text{ kV}$

The sending end line-to-line voltage magnitude  $V_{S(L-L)} = \sqrt{3} \times 121.39$   
 $= 210.26 \text{ kV}$

The sending end power  $\bar{S}_{S(3\phi)} = 3\bar{V}_S\bar{I}_S^*$

$$= 3(121.39 \angle 9.29^\circ)(1000 \angle -36.87^\circ) = 322.8 \text{ MW} - j168.6 \text{ Mvar}$$

$$= 361.8 \angle -27.58^\circ \text{ MVA}$$

Voltage regulation =  $\frac{210.26 - 220}{220} = -0.0443$

Transmission line efficiency  $\eta = \frac{P_R(3\phi)}{P_S(3\phi)} = \frac{304.8}{322.8} = 0.944$

5.12 (a) The nominal  $\pi$  circuit is shown below:

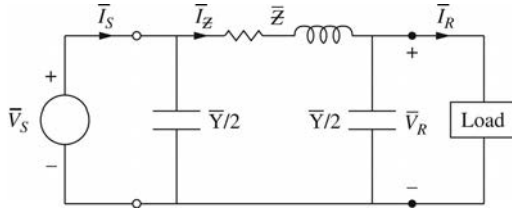

$$\begin{aligned} \text{The total line impedance } \bar{Z} &= (0.1826 + j0.784)100 = 18.26 + j78.4 \\ &= 80.5 \angle 76.89^\circ \Omega/\text{ph}. \end{aligned}$$

The line admittance for 100 mi is

$$\bar{Y} = \frac{1}{X_C} \angle 90^\circ = \frac{1}{\frac{185.5 \times 10^3}{100}} \angle 90^\circ = 0.5391 \times 10^{-3} \angle 90^\circ \text{ S/ph}.$$

$$(b) \bar{V}_R = \frac{230}{\sqrt{3}} \angle 0^\circ = 132.8 \angle 0^\circ \text{ kV}$$

$$\bar{I}_R = \frac{200 \times 10^3}{\sqrt{3}(230)} \angle 0^\circ = 502 \angle 0^\circ \text{ A } (\because \text{Unity Power Factor})$$

$$\begin{aligned} \bar{I}_z &= \bar{I}_R + \bar{V}_R \left( \frac{\bar{Y}}{2} \right) = 502 \angle 0^\circ + (132,800 \angle 0^\circ)(0.27 \times 10^{-3} \angle 90^\circ) \\ &= 502 + j35.86 = 503.3 \angle 4.09^\circ \text{ A} \end{aligned}$$

$$\begin{aligned} \text{The sending end voltage } \bar{V}_S &= 132.8 \angle 0^\circ + (0.5033 \angle 4.09^\circ)(80.5 \angle 76.89^\circ) \\ &= 139.152 + j40.01 = 144.79 \angle 16.04^\circ \text{ kV} \end{aligned}$$

The line-to-line voltage magnitude at the sending end is  $\sqrt{3}(144.79) = 250.784 \text{ kV}$

$$\begin{aligned} \bar{I}_S &= \bar{I}_z + \bar{V}_S \left( \frac{\bar{Y}}{2} \right) = 502 + j35.86 + (144.79 \angle 16.04^\circ)(0.27 \angle 90^\circ) \\ &= 491.2 + j73.46 = 496.7 \angle 8.5^\circ \text{ A} \end{aligned}$$

$$\begin{aligned} \text{Sending end power } \bar{S}_{S(3\phi)} &= 3(144.79)(0.4967) \angle 16.04^\circ - 8.5^\circ \\ &= 213.88 + j28.31 \text{ MVA} \end{aligned}$$

So  $P_{S(3\phi)} = 213.88 \text{ MW}$ ;  $Q_{S(3\phi)} = 28.31 \text{ MVAR}$

$$(c) \text{ Regulation} = \frac{V_S - V_R}{V_R} = \frac{144.79 - 132.8}{132.8} = 0.09$$

$$5.13 \quad \bar{\gamma}l = 0.4 \angle 85^\circ = 0.034862 + j0.39848$$

$$\begin{aligned} e^{\bar{\gamma}l} &= e^{0.034862} e^{j0.39848} = 1.03548 \angle 0.39848 \text{ radians} \\ &= 0.9543 + j0.40178 \end{aligned}$$

$$e^{-\bar{\gamma}l} = e^{-0.034862} e^{-j0.39848} = 0.965738 \angle -0.39848 \text{ radians} \\ = 0.89007 - j0.37472$$

$$\cosh \bar{\gamma}l = \frac{e^{\bar{\gamma}l} + e^{-\bar{\gamma}l}}{2} = \frac{[(0.9543 + j0.40178) + (0.89007 - j0.37472)]}{2} \\ = 0.92219 + j0.01353 = 0.9223 \angle 0.841^\circ \text{ pu}$$

Alternatively:

$$\cosh(0.034862 + j0.39848) = \cosh(0.034862) \cos(0.39848 \text{ radians}) \\ + j \sinh(0.034862) \sin(0.39848 \text{ radians}) \\ = (1.00060)(0.92165) + j(0.034869)(0.388018) \\ = 0.9222 + j0.01353 = 0.9223 \angle 0.841^\circ \text{ pu}$$

$$\sinh \bar{\gamma}l = \frac{e^{\bar{\gamma}l} - e^{-\bar{\gamma}l}}{2} = \frac{[(0.9543 + j0.40178) - (0.89007 - j0.37472)]}{2} \\ = 0.03212 + j0.38825 = 0.38958 \angle 85.271^\circ \text{ pu}$$

$$\tanh\left(\frac{\bar{\gamma}l}{2}\right) = \frac{\cosh(\bar{\gamma}l) - 1}{\sinh(\bar{\gamma}l)} = \frac{(0.9222 + j0.01353) - 1}{0.38958 \angle 85.271^\circ} \\ = \frac{0.07897 \angle 170.13^\circ}{0.38958 \angle 85.271^\circ} = 0.2027 \angle 84.86^\circ \text{ pu}$$

5.14 (a)  $\bar{Z}_c = \sqrt{\frac{\bar{z}}{\bar{y}}} = \sqrt{\frac{0.03 + j0.35}{4.4 \times 10^{-6} \angle 90^\circ}} = 282.6 \angle -2.45^\circ \Omega$

(b)  $\bar{\gamma}l = \sqrt{\bar{z}\bar{y}}(l) = \sqrt{(0.35128 \angle 85.101^\circ)(4.4 \times 10^{-6} \angle 90^\circ)}(400) \\ = 0.4973 \angle 87.55^\circ = 0.02126 + j0.4968 \text{ pu}$

(c)  $\bar{A} = \bar{D} = \cosh \bar{\gamma}l = \cosh(0.02126 + j0.4968) \\ = (\cosh 0.02126)(\cos 0.4968 \text{ radians}) + j(\sinh 0.02126)(\sin 0.4968 \text{ radians}) \\ = (1.00023)(0.87911) + j(0.02126)(0.47661) \\ = 0.87931 + j0.01013 = 0.8794 \angle 0.66^\circ \text{ pu}$

$$\sinh \bar{\gamma}l = \sinh(0.02126 + j0.4968) \\ = \sinh(0.02126) \cos(0.4968 \text{ radians}) + j(\cosh 0.02126)(\sin 0.4968 \text{ radians}) \\ = (0.02126)(0.87911) + j(1.00023)(0.47661) \\ = 0.01869 + j0.4767 = 0.4771 \angle 87.75^\circ$$

$$\bar{B} = \bar{Z}_c \sinh(\bar{\gamma}l) = (282.6 \angle -2.45^\circ)(0.4771 \angle 87.75^\circ) \\ = 134.8 \angle 85.3^\circ \Omega$$

$$\bar{C} = \frac{1}{\bar{Z}_c} \sinh(\bar{\gamma}l) = \frac{0.4771 \angle 87.75^\circ}{282.6 \angle -2.45^\circ} = 1.688 \times 10^{-3} \angle 90.2^\circ \text{ S}$$

$$5.15 \quad \bar{V}_R = (475/\sqrt{3})\angle 0^\circ = 274.2\angle 0^\circ \text{ kV}_{L-N}$$

$$\bar{I}_R = \frac{P_R \angle \cos^{-1}(pf)}{\sqrt{3} V_{RL}(pf)} = \frac{1000 \angle \cos^{-1} 1.0}{\sqrt{3} (475)(1.0)} = 1.215 \angle 0^\circ \text{ kA}$$

$$(a) \quad \bar{V}_S = \bar{A}\bar{V}_R + \bar{B}\bar{I}_R = (0.8794 \angle 0.66^\circ)(274.2 \angle 0^\circ) + (134.8 \angle 85.3^\circ)(1.215 \angle 0^\circ)$$

$$= 241.13 \angle 0.66^\circ + 163.78 \angle 85.3^\circ$$

$$= 254.5 + j163.2 = 303.9 \angle 33.11^\circ \text{ kV}_{L-N}$$

$$V_{S L-L} = 303.9\sqrt{3} = 526.4 \text{ kV}$$

$$(b) \quad \bar{I}_S = \bar{C}\bar{V}_R + \bar{D}\bar{I}_R = (1.688 \times 10^{-3} \angle 90.2^\circ)(274.2 \angle 0^\circ) + (0.8794 \angle 0.66^\circ)(1.215 \angle 0^\circ)$$

$$= 0.4628 \angle 90.2^\circ + 1.0685 \angle 0.66^\circ$$

$$= 1.0668 + j0.4751 = 1.168 \angle 24.01^\circ \text{ kA}$$

$$I_S = 1.168 \text{ kA}$$

$$(c) \quad PF_S = \cos(32.67 - 24.01) = \cos(8.66^\circ) = 0.989 \text{ Lagging}$$

$$(d) \quad P_S = \sqrt{3} V_{S LL} I_S (pf_S)$$

$$= \sqrt{3} (526.4)(1.168)(0.989) = 1053.2 \text{ MW}$$

$$\text{Full-load line losses} = P_S - P_R = 1053.2 - 1000 = 53.2 \text{ MW}$$

$$(e) \quad V_{R NL} = V_S / A = 526.4 / 0.8794 = 598.6 \text{ kV}_{L-L}$$

$$\% VR = \frac{V_{R NL} - V_{R FL}}{V_{R FL}} \times 100 = \frac{598.6 - 475}{475} = 26\%$$

5.16 Table A.4 three ACSR finch conductors per phase

$$r = \frac{0.0969 \Omega}{3 \text{ mi}} \left( \frac{1 \text{ mi}}{1.609 \text{ km}} \right) = 0.02 \Omega / \text{km}$$

$$(a) \quad \bar{Z}_C = \sqrt{\bar{z} / \bar{y}} = \sqrt{\frac{0.336 \angle 86.6^\circ}{4.807 \times 10^{-6} \angle 90^\circ}} = 264.4 \angle -1.7^\circ \Omega$$

$$(b) \quad \bar{\gamma}l = \sqrt{\bar{z}\bar{y}} l = \sqrt{0.336 \times 4.807 \times 10^{-6} \angle 86.6^\circ + 90^\circ} (300)$$

$$= 0.0113 + j0.381 \text{ pu}$$

$$(c) \quad \bar{A} = \bar{D} = \cosh(\bar{\gamma}l) = \cosh(0.0113 + j0.381)$$

$$= \cosh 0.0113 \cos 0.381 + j \sinh 0.0113 \sin 0.381$$

$$= 0.9285 + j0.00418 = 0.9285 \angle 0.258^\circ \text{ pu}$$

$$\sinh \bar{\gamma}l = \sinh(0.0113 + j0.381)$$

$$= \sinh 0.0113 \cos 0.381 + j \cosh 0.0113 \sin 0.381$$

$$= 0.01045 + j0.3715 = 0.3716 \angle 88.39^\circ$$

$$\begin{aligned}\bar{B} &= \bar{Z}_C \sinh \bar{\gamma}l = 264.4 \angle -1.7^\circ (0.3716 \angle 88.39^\circ) \\ &= 98.25 \angle 86.69^\circ \Omega \\ \bar{C} &= \sinh \bar{\gamma}l / \bar{Z}_C = 0.3716 \angle 88.39^\circ / (264.4 \angle -1.7^\circ) \\ &= 1.405 \times 10^{-3} \angle 90.09^\circ \text{ S}\end{aligned}$$

$$5.17 \quad \bar{V}_R = (480 / \sqrt{3}) \angle 0^\circ = 277.1 \angle 0^\circ \text{ kV}_{\text{LN}}$$

$$\begin{aligned}\text{(a)} \quad \bar{I}_R &= \frac{1500}{480\sqrt{3}} \angle -\cos^{-1} 0.9 = 1.804 \angle -25.84^\circ \text{ kA} \\ \bar{V}_S &= \bar{A}\bar{V}_R + \bar{B}\bar{I}_R = 0.9285 \angle 0.258^\circ (277.1) + 98.25 \angle 86.69^\circ (1.804 \angle -25.84^\circ) \\ &= 377.4 \angle 24.42^\circ \text{ kV}_{\text{LN}}; V_S = 377.4\sqrt{3} = 653.7 \text{ kV}_{\text{LL}} \\ V_{RNL} &= V_S / A = 653.7 / 0.9285 = 704 \text{ kV}_{\text{LL}} \\ \% VR &= \frac{V_{RNL} - V_{RFL}}{V_{RFL}} \times 100 = \frac{704 - 480}{480} \times 100 = 46.7\%\end{aligned}$$

$$\begin{aligned}\text{(b)} \quad \bar{V}_S &= 0.9285 \angle 0.258^\circ (277.1) + 98.25 \angle 86.69^\circ (1.804 \angle 0^\circ) \\ &= 321.4 \angle 33.66^\circ \text{ kV}_{\text{LN}}; V_S = 321.4\sqrt{3} = 556.7 \text{ kV}_{\text{LL}} \\ V_{RNL} &= V_S / A = 556.7 / 0.9285 = 599.5 \text{ kV}_{\text{LL}} \\ \% VR &= \frac{599.5 - 480}{480} \times 100 = 24.9\%\end{aligned}$$

$$\begin{aligned}\text{(c)} \quad \bar{V}_S &= 257.3 \angle 0.258^\circ + 177.24 \angle 112.5^\circ \\ &= 251.2 \angle 41.03^\circ \text{ kV}_{\text{LN}} \\ V_S &= 251.2\sqrt{3} = 435.1 \text{ kV}_{\text{LL}} \\ V_{RNL} &= V_S / A = 435.1 / 0.9285 = 468.6 \text{ kV}_{\text{LL}} \\ \% VR &= \frac{468.6 - 480}{4.80} \times 100 = -2.4\%\end{aligned}$$

$$\begin{aligned}5.18 \quad \bar{\gamma}l &= l\sqrt{\bar{y}\bar{z}} = 230 \left( \sqrt{0.843 \times 5.105 \times 10^{-6}} \right) \angle (79.04^\circ + 90^\circ) / 2 \\ &= 0.4772 \angle 84.52^\circ = 0.0456 + j0.475 = (\alpha + j\beta)l\end{aligned}$$

$$\bar{Z}_C = \sqrt{\frac{\bar{z}}{\bar{y}}} = \sqrt{\frac{0.8431}{5.105 \times 10^{-6}}} \angle (79.04^\circ - 90^\circ) / 2 = 406.4 \angle -5.48^\circ \Omega$$

$$\bar{V}_R = \frac{215}{\sqrt{3}} = 124.13 \angle 0^\circ \text{ kV/ph.}; \bar{I}_R = \frac{125 \times 10^3}{\sqrt{3} \times 215} \angle 0^\circ = 335.7 \angle 0^\circ \text{ A}$$

$$\cosh \bar{\gamma}l = \frac{1}{2} e^{0.0456} \angle 27.22^\circ + \frac{1}{2} e^{-0.0456} \angle -27.22^\circ = 0.8904 \angle 1.34^\circ$$

$$\sinh \bar{\gamma}l = \frac{1}{2}e^{0.0456} \angle 27.22^\circ - \frac{1}{2}e^{-0.0456} \angle -27.22^\circ = 0.4597 \angle 84.93^\circ$$

$$\begin{aligned}\bar{V}_S &= \bar{V}_R \cosh \bar{\gamma}l + \bar{I}_R \bar{Z}_C \sinh \bar{\gamma}l \\ &= (124.13 \times 0.8904 \angle 1.34^\circ) + (0.3357 \times 406.4 \angle -5.48^\circ \times 0.4597 \angle 84.93^\circ) \\ &= 137.86 \angle 27.77^\circ \text{ kV}\end{aligned}$$

Line-to-Line voltage magnitude at the sending end is  $\sqrt{3} 137.86 = 238.8 \text{ kV}$

$$\begin{aligned}\bar{I}_S &= \bar{I}_R \cosh \bar{\gamma}l + \frac{\bar{V}_R}{\bar{Z}_C} \sinh \bar{\gamma}l = (335.7 \times 0.8904 \angle 1.34^\circ) + \\ &\quad \frac{124,130}{406.4 \angle -5.48^\circ} \times 0.4597 \angle 84.93^\circ \\ &= 332.31 \angle 26.33^\circ \text{ A}\end{aligned}$$

Sending-end line current magnitude is 332.31 A

$$P_{S(3\phi)} = \sqrt{3} (238.8)(332.31) \cos (27.77^\circ - 26.33^\circ) = 137,433 \text{ kW}$$

$$Q_{R(3\phi)} = \sqrt{3} (238.8)(332.31) \sin (27.77^\circ - 26.33^\circ) = 3454 \text{ kVAR}$$

$$\text{Voltage Regulation} = \frac{(137.86/0.8904) - 124.13}{124.13} = 0.247$$

(Note that at no load,  $\bar{I}_R = 0$ ;  $\bar{V}_R = \bar{V}_S / \cosh \bar{\gamma}l$ )

since  $\beta = 0.475 / 230 = 0.002065 \text{ rad/mi}$

$$\text{The wavelength } \lambda = \frac{2\pi}{\beta} = \frac{2\pi}{0.002065} = 3043 \text{ mi}$$

$$\begin{aligned}\text{and the velocity of propagation} &= f \lambda = 60 \times 3043 \\ &= 182,580 \text{ mi/s}\end{aligned}$$

### 5.19 Choosing a base of 125 MVA and 215 kV,

$$\text{Base Impedance} = \frac{(215)^2}{125} = 370 \text{ } \Omega; \text{ Base Current} = \frac{125 \times 10^3}{\sqrt{3} \times 215} = 335.7 \text{ A}$$

$$\text{So } \bar{Z}_C = \frac{406.4 \angle -5.48^\circ}{370} = 1.098 \angle -5.48 \text{ pu}; \bar{V}_R = 1 \angle 0^\circ \text{ pu}$$

The load being at unity pf,  $\bar{I}_R = 1.0 \angle 0^\circ \text{ pu}$

$$\begin{aligned}\therefore \bar{V}_S &= \bar{V}_R \cosh \bar{\gamma}l + \bar{I}_R \bar{Z}_C \sinh \bar{\gamma}l \\ &= (1 \angle 0^\circ \times 0.8904 \angle 1.34^\circ) + (1 \angle 0^\circ \times 1.098 \angle -5.48^\circ \times 0.4597 \angle 84.93^\circ) \\ &= 1.1102 \angle 27.75^\circ \text{ pu}\end{aligned}$$

$$\begin{aligned}\bar{I}_S &= \bar{I}_R \cosh \bar{\gamma}l + \frac{\bar{V}_R}{\bar{Z}_C} \sinh \bar{\gamma}l \\ &= (1\angle 0^\circ \times 0.8904\angle 1.34^\circ) + \left( \frac{1.0\angle 0^\circ}{1.098\angle -5.48^\circ} \times 0.4597\angle 84.93^\circ \right) \\ &= 0.99\angle 26.35^\circ \text{ pu}\end{aligned}$$

At the sending end

$$\begin{aligned}\text{Line to line voltage magnitude} &= 1.1102 \times 215 \\ &= 238.7 \text{ kV}\end{aligned}$$

$$\begin{aligned}\text{Line Current Magnitude} &= 0.99 \times 335.7 \\ &= 332.3 \text{ A}\end{aligned}$$

**5.20** (a) Let  $\bar{\theta} = \bar{\gamma}l = \sqrt{\bar{Z}\bar{Y}}$

$$\begin{aligned}\text{Then } \bar{A} &= 1 + \frac{\bar{Z}\bar{Y}}{2} + \frac{\bar{Z}^2\bar{Y}^2}{24} + \frac{\bar{Z}^3\bar{Y}^3}{720} + \dots \text{ which is } \cosh \bar{\gamma}l \\ \bar{B} &= \bar{Z}_C \left( 1 + \frac{\bar{Z}\bar{Y}}{6} + \frac{\bar{Z}^2\bar{Y}^2}{120} + \frac{\bar{Z}^3\bar{Y}^3}{5040} + \dots \right) \text{ which is } \bar{Z}_C \sinh \bar{\gamma}l \\ \bar{C} &= \frac{1}{\bar{Z}_C} \sinh \bar{\gamma}l = \frac{1}{\bar{Z}_C} \left( 1 + \frac{\bar{Z}\bar{Y}}{6} + \frac{\bar{Z}^2\bar{Y}^2}{120} + \frac{\bar{Z}^3\bar{Y}^3}{5040} + \dots \right) \\ \bar{D} &= \bar{A}\end{aligned}$$

Considering only the first two terms,

$$\left. \begin{aligned}\bar{A} = \bar{D} &= 1 + \frac{\bar{Z}\bar{Y}}{2} \\ \bar{B} &= \bar{Z}_C \left( 1 + \frac{\bar{Z}\bar{Y}}{6} \right) \\ \bar{C} &= \frac{1}{\bar{Z}_C} \left( 1 + \frac{\bar{Z}\bar{Y}}{6} \right)\end{aligned} \right\} \leftarrow$$

(b) Refer to Table 5.1 of the text.

$$\text{For Nominal-}\pi \text{ circuit: } \frac{\bar{A}-1}{\bar{B}} = \frac{\bar{Y}}{2}; \bar{B} = \bar{Z} \leftarrow$$

$$\text{For Equivalent-}\pi \text{ circuit: } \frac{\bar{A}-1}{\bar{B}} = \frac{\bar{Y}'}{2}; \bar{B} = \bar{Z}' \leftarrow$$

**5.21** Eq. (5.1.1):

$$\begin{aligned}\bar{V}_S &= \bar{A}\bar{V}_R + \bar{B}\bar{I}_R \\ \bar{V}_S\bar{I}_S &= \bar{A}\bar{V}_R\bar{I}_S + \bar{B}\bar{I}_R\bar{I}_S\end{aligned}$$

Substituting  $\bar{I}_S = \bar{C}\bar{V}_R + \bar{D}\bar{I}_R$  and  $\bar{A} = \bar{D}$

$$\bar{V}_S\bar{I}_S = \bar{A}\bar{V}_R\bar{I}_S + \bar{B}\bar{I}_R(\bar{C}\bar{V}_R + \bar{A}\bar{I}_R)$$

Now adding  $\bar{V}_R\bar{I}_R$  on both sides,

$$\bar{V}_S\bar{I}_S + \bar{V}_R\bar{I}_R = \bar{A}\bar{V}_R\bar{I}_S + (\bar{B}\bar{C} + 1)\bar{V}_R\bar{I}_R + \bar{B}\bar{A}\bar{I}_R^2$$

But  $\bar{A}^2 - \bar{B}\bar{C} = 1$

Hence  $\bar{V}_S\bar{I}_S + \bar{V}_R\bar{I}_R = \bar{A}\bar{V}_R\bar{I}_S + \bar{A}^2\bar{V}_R\bar{I}_R + \bar{B}\bar{A}\bar{I}_R^2 = \bar{A}(\bar{V}_R\bar{I}_S + \bar{V}_S\bar{I}_R)$

$$\therefore \bar{A} = \frac{\bar{V}_S\bar{I}_S + \bar{V}_R\bar{I}_R}{\bar{V}_R\bar{I}_S + \bar{V}_S\bar{I}_R} \leftarrow$$

Now  $\bar{B} = \frac{\bar{V}_S - \bar{A}\bar{V}_R}{\bar{I}_R}$ ; substituting the above result

$$\text{For } \bar{A}, \text{ one obtains } \bar{B} = \frac{\bar{V}_S}{\bar{I}_R} - \frac{\bar{V}_R}{\bar{I}_R} \left( \frac{\bar{V}_S\bar{I}_S + \bar{V}_R\bar{I}_R}{\bar{V}_R\bar{I}_S + \bar{V}_S\bar{I}_R} \right)$$

$$\text{Thus } \bar{B} = \frac{\bar{V}_S\bar{V}_R\bar{I}_S + \bar{V}_S^2\bar{I}_R - \bar{V}_R\bar{V}_S\bar{I}_S - \bar{V}_R^2\bar{I}_R}{\bar{I}_R(\bar{V}_R\bar{I}_S + \bar{V}_S\bar{I}_R)}$$

$$\text{or } \bar{B} = \frac{\bar{V}_S^2 - \bar{V}_R^2}{\bar{V}_R\bar{I}_S + \bar{V}_S\bar{I}_R} \leftarrow$$

$$5.22 \quad \bar{A} = \frac{e^{\bar{\theta}} + e^{-\bar{\theta}}}{2}; \text{ with } \bar{X} = e^{-\bar{\theta}}, \bar{A} = \frac{1}{\bar{X}} + \bar{X}$$

or  $\bar{X}^2 - 2\bar{A}\bar{X} + 1 = 0$ ; Substituting  $\bar{X} = X_1 + jX_2$

And  $\bar{A} = A_1 + jA_2$ , one gets

$$X_1^2 - X_2^2 + 2jX_1X_2 - 2[A_1X_1 - A_2X_2 + j(A_2X_1 + A_1X_2)] + 1 = 0$$

$$\left. \begin{aligned} \text{which implies } X_1^2 - X_2^2 - 2[A_1X_1 - A_2X_2] + 1 &= 0 \\ \text{and } X_1X_2 - (A_2X_1 + A_1X_2) &= 0 \end{aligned} \right\} \leftarrow$$

5.23 Equivalent  $\pi$  circuit:

$$\bar{Z}' = B = 134.8 \angle 85.3^\circ = (11.0 + j134.3) \Omega = R' + jx'$$



Alternatively:

$$\begin{aligned}\bar{Z}' &= \bar{Z} \bar{F}_1 = (\bar{z}l) \frac{\sinh \bar{\gamma}l}{\bar{\gamma}l} \\ &= (0.35128 \angle 85.1^\circ) 400 \left[ \frac{0.4771 \angle 87.75^\circ}{0.4973 \angle 87.55^\circ} \right] \\ &= 134.8 \angle 85.3^\circ \Omega\end{aligned}$$

$$\begin{aligned}\frac{\bar{Y}'}{2} &= \frac{\bar{Y}}{2} \bar{F}_2 = \frac{\bar{y}l}{2} \left[ \frac{\tanh(\bar{\gamma}l/2)}{(\bar{\gamma}l/2)} \right] = \frac{\bar{y}l}{2} \left[ \frac{\cosh \bar{\gamma}l - 1}{\frac{\bar{\gamma}l}{2} \cdot \sinh \bar{\gamma}l} \right] \\ &= \left( \frac{4.4 \times 10^{-6}}{2} \angle 90^\circ \right) (400) \left[ \frac{0.87931 + j0.01013 - 1}{(0.2487 \angle 87.55^\circ)(0.4771 \angle 87.75^\circ)} \right] \\ &= 8.981 \times 10^{-4} \angle 89.9^\circ \text{ S} = (1.57 \times 10^{-6} + j8.981 \times 10^{-4}) \text{ S} = \frac{G' + jB'}{2}\end{aligned}$$

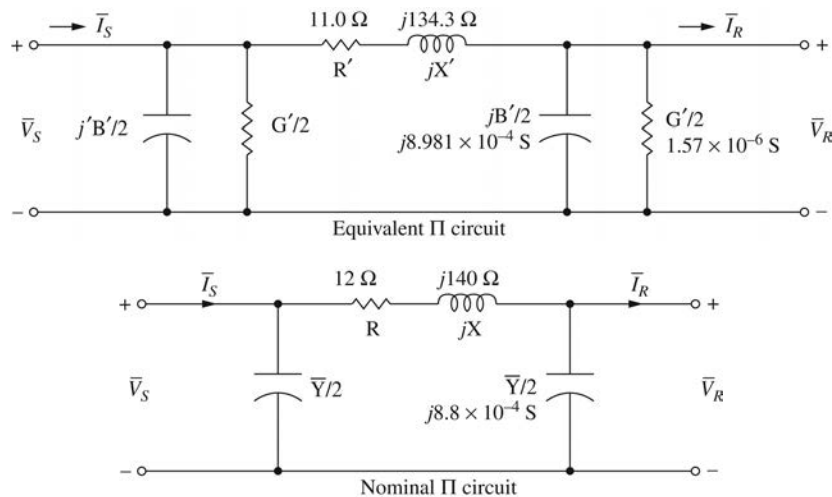

$R' = 11 \Omega$  is 8% smaller than  $R = 12 \Omega$

$X' = 134.3 \Omega$  is 4% smaller than  $X = 140 \Omega$

$B' / 2 = 8.981 \times 10^{-4} \text{ S}$  is 2% larger than  $Y / 2 = 8.8 \times 10^{-4} \text{ S}$

$G' / 2 = 1.57 \times 10^{-6} \text{ S}$  is introduced into the equivalent  $\pi$  circuit.

5.24  $\bar{Z}' = \bar{B} = 98.25 \angle 86.69^\circ \Omega = 5.673 + j98.09 \Omega$

$$\begin{aligned} \frac{\bar{Y}'}{2} &= \left(\frac{\bar{Y}}{2}\right) \bar{F}_2 = \left(\frac{4.807}{2} \times 10^{-6} \angle 90^\circ \times 300\right) \left[\frac{\cosh \bar{\gamma}l - 1}{\frac{\bar{\gamma}l}{2} \sinh \bar{\gamma}l}\right] \\ &= \left(\frac{1.442}{2} \times 10^{-3} \angle 90^\circ\right) \left[\frac{0.9285 + j0.00418 - 1}{\frac{0.3812}{2} \angle 88.3^\circ (0.3716 \angle 88.39^\circ)}\right] \\ &= 7.21 \times 10^{-4} \angle 90^\circ \left[\frac{-0.0715 + j0.00418}{0.0708 \angle 176.7^\circ}\right] \\ &= 6.37 \times 10^{-7} + j7.294 \times 10^{-4} \text{ S} \end{aligned}$$

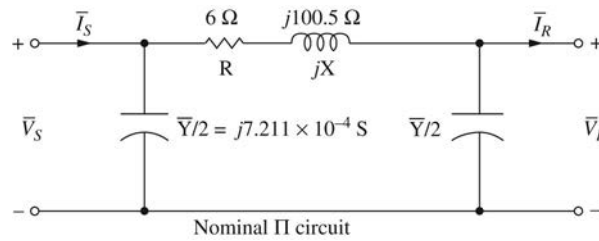
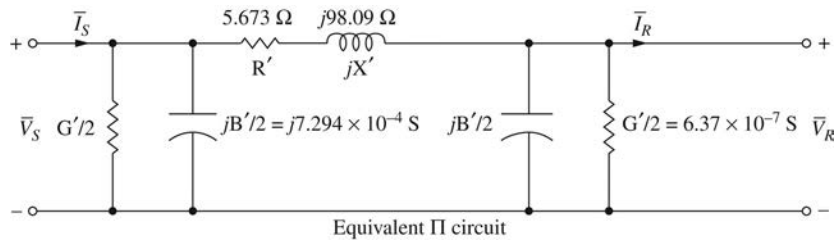

$R' = 5.673 \Omega$  is 5.5% smaller than  $R = 6 \Omega$

$X' = 98.09 \Omega$  is 2.4% smaller than  $X = 100.5 \Omega$

$B'/2 = 7.294 \times 10^{-4} \text{ S}$  is 1.2% larger than  $Y/2 = 7.211 \times 10^{-4} \text{ S}$

$G'/2 = 6.37 \times 10^{-7} \text{ S}$  is introduced into the equivalent  $\pi$  circuit

5.25 The long line  $\pi$ -equivalent circuit is shown below:

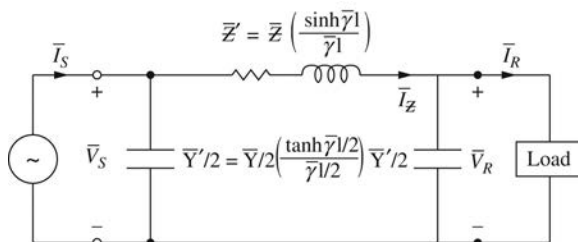

$$\bar{z} = (0.1826 + j0.784) \Omega / \text{mi per phase}$$

$$\bar{y} = \frac{1}{x_c \angle -90^\circ} = \frac{1}{185.5 \times 10^3 \angle -90^\circ} = 5.391 \times 10^{-6} \angle 90^\circ \text{ S/mi per phase}$$

$$\bar{\gamma} = \sqrt{\bar{y} \bar{z}}; \bar{Z} = \bar{z}l = 160.99 \angle 76.89^\circ \Omega; \bar{Y} = \bar{y}l = 1.078 \times 10^{-3} \angle 90^\circ \text{ S}$$

$$\bar{F}_1 = (\sinh \bar{\gamma}l) / \bar{\gamma}l = 0.972 \angle 0.37^\circ; \bar{F}_2 = \frac{\tanh(\bar{\gamma}l/2)}{\bar{\gamma}l/2} = 1.0144 \angle -0.19^\circ$$

$$\therefore \bar{Z}' = \bar{Z} \frac{\sinh \bar{\gamma}l}{\bar{\gamma}l} = 156.48 \angle 77.26^\circ \Omega$$

$$\frac{\bar{Y}'}{2} = \frac{\bar{Y}}{2} \left( \frac{\tanh(\bar{\gamma}l/2)}{\bar{\gamma}l/2} \right) = 0.5476 \times 10^{-3} \angle 89.81^\circ \text{ S}$$

$$\begin{aligned} \bar{I}_{Z'} &= \bar{I}_R + \bar{V}_R \frac{\bar{Y}'}{2} = 502 \angle 0^\circ + (132,800 \angle 0^\circ)(0.5476 \times 10^{-3} \angle 89.81^\circ) \\ &= 507.5 \angle 8.24^\circ \text{ A} \end{aligned}$$

$$\begin{aligned} \bar{V}_S &= \bar{V}_R + \bar{I}_{Z'} \bar{Z}' = 132,800 \angle 0^\circ + 507.5 \angle 8.24^\circ (156.48 \angle 77.26^\circ) \\ &= 160,835 \angle 29.45^\circ \text{ V} \end{aligned}$$

(a) Sending end line to line voltage magnitude =  $\sqrt{3} 160.835 = 278.6 \text{ kV}$

(b)  $\bar{I}_S = \bar{I}_{Z'} + \bar{V}_S \left( \frac{\bar{Y}'}{2} \right) = 507.5 \angle 8.24^\circ + 160.835 (0.5476) \angle 29.45 + 89.81^\circ$   
 $= 482.93 \angle 18.04^\circ \text{ A}; I_S = 482.93 \text{ A}$

(c)  $\bar{S}_{S(3\phi)} = 3\bar{V}_S \bar{I}_S^* = 3(160.835)(0.48293) \angle 29.45^\circ - 18.04^\circ$   
 $= 228.41 \text{ MW} + j46.1 \text{ M var}$

(d) Percent voltage regulation =  $\frac{160.835 - 132.8}{132.8} \times 100 = 21.1\%$

**5.26** (a)  $\bar{Z}_C = \sqrt{\frac{\bar{z}}{\bar{y}}} = \sqrt{\frac{j0.34}{j4.5 \times 10^{-6}}} = 274.9 \angle 0^\circ = 274.9 \Omega$

(b)  $\bar{\gamma}l = \sqrt{\bar{z} \bar{y}} (l) = \sqrt{(j0.34)(j4.5 \times 10^{-6})} (300) = j0.3711 \text{ pu}$

(c)  $\bar{\gamma}l = j(\beta l); \beta l = 0.3711 \text{ pu}$

$$A = D = \cos(\beta l) = \cos(0.3711 \text{ radians}) = 0.9319 \angle 0^\circ \text{ pu}$$

$$\begin{aligned} \bar{B} &= j Z_C \sin(\beta l) = j(274.9) \sin(0.3711 \text{ radians}) \\ &= j99.68 \Omega \end{aligned}$$

$$\begin{aligned} \bar{C} &= j \left( \frac{1}{Z_C} \right) \sin(\beta l) = j \left( \frac{1}{274.9} \right) \sin(0.3711 \text{ radians}) \\ &= j1.319 \times 10^{-3} \text{ S} \end{aligned}$$

$$(d) \beta = 0.3711 / 300 = 1.237 \times 10^{-3} \text{ radians/km}$$

$$\lambda = 2\pi/\beta = 5079 \text{ km}$$

$$(e) \text{ SIL} = \frac{V_{\text{rated } L-L}^2}{Z_C} = \frac{(500)^2}{274.9} = 909.4 \text{ MW (3}\phi\text{)}$$

$$5.27 \quad \bar{Z}' = \bar{B} = j99.68 \Omega$$

Alternatively:

$$\begin{aligned} \bar{Z}' &= \bar{Z} \bar{F}_1 = (\bar{z}l) \frac{\sin \beta l}{\beta l} = (j0.34 \times 300) \left[ \frac{\sin(0.3711 \text{ radians})}{0.3711} \right] \\ &= (j102)(0.97721) = j99.68 \Omega \end{aligned}$$

$$\begin{aligned} \frac{\bar{Y}'}{2} &= \frac{\bar{Y}}{2} \bar{F}_2 = \left( \frac{\bar{y}}{2} l \right) \frac{\tan(\beta l / 2)}{(\beta l / 2)} = j \frac{4.5 \times 10^{-6}}{2} \times 300 \left[ \frac{\tan(0.1855 \text{ radians})}{0.1855} \right] \\ &= (j6.75 \times 10^{-4})(1.012) = j6.829 \times 10^{-4} \text{ S} \end{aligned}$$

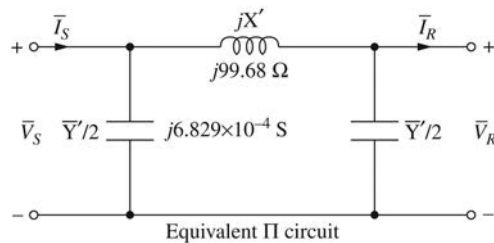

$$5.28 \quad (a) V_R = V_S / A = 500 / 0.9319 = 536.5 \text{ kV}$$

$$(b) V_R = V_S = 500 \text{ kV}$$

$$(c) \bar{V}_S = \cos(\beta l) \cdot \bar{V}_R + (jZ_C \sin \beta l) \left( \frac{\bar{V}_R}{\frac{1}{Z_C}} \right)$$

$$\bar{V}_S = |\cos \beta l + jZ \sin \beta l| V_R$$

$$V_S = 500 / |\cos 0.3711 \text{ radians} + j2 \sin 0.3711 \text{ radians}|$$

$$= 500 / 1.18 = 423.4 \text{ kV}$$

$$(d) P_{\text{max } 3\phi} = \frac{V_S V_R}{X'} = \frac{(500)(500)}{99.68} = 2508 \text{ MW}$$

5.29 Reworking Problem 5.9:

$$(a) \bar{z} = j0.506 \Omega / \text{km}$$

$$\bar{A} = \bar{D} = 1 + \frac{\bar{Y} \bar{Z}}{2} = 1 + \frac{1}{2} (3.229 \times 10^{-4} \angle 90^\circ)(50.6 \angle 90^\circ) = 0.9918 \text{ pu}$$

$$\bar{B} = \bar{Z} = \bar{z}l = j50.6 \Omega$$

$$\begin{aligned}\bar{C} &= \bar{Y} \left( 1 + \frac{\bar{Y} \bar{Z}}{4} \right) = 3.229 \times 10^{-4} \angle 90^\circ (1 - 0.004085) \\ &= 3.216 \times 10^{-4} \angle 90^\circ \text{ S}\end{aligned}$$

$$\begin{aligned}\bar{V}_S &= \bar{A} \bar{V}_R + \bar{B} \bar{I}_R = 0.9918(125.9) + j50.6(0.7945 \angle -25.84^\circ) \\ &= 146.9 \angle 14.26^\circ \text{ kV}_{\text{LN}}\end{aligned}$$

$$V_S = 146.9 \sqrt{3} = 254.4 \text{ kV}_{\text{LL}}$$

$$V_{RNL} = V_S / A = 254.4 / 0.9918 = 256.5 \text{ kV}_{\text{LL}}$$

$$\% VR = \frac{V_{RNL} - V_{RFL}}{V_{RFL}} \times 100 = \frac{256.5 - 218}{218} \times 100 = 17.7\%$$

$$\begin{aligned}\text{(b) } \bar{V}_S &= 0.9918(125.9) + j50.6(0.7945 \angle 0^\circ) \\ &= 124.86 + j40.2 = 131.2 \angle 17.85^\circ \text{ kV}_{\text{LN}}\end{aligned}$$

$$V_S = 131.2 \sqrt{3} = 227.2 \text{ kV}_{\text{LL}}$$

$$V_{RNL} = V_S / A = 227.2 / 0.9918 = 229.1 \text{ kV}$$

$$\% VR = \frac{229.1 - 218}{218} \times 100 = 5.08\%$$

$$\begin{aligned}\text{(c) } \bar{V}_S &= 0.9918(125.9) + j50.6(0.7945 \angle 25.84^\circ) \\ &= 107.34 + j36.18 = 113.3 \angle 18.63^\circ\end{aligned}$$

$$V_S = 113.3 \sqrt{3} = 196.2 \text{ kV}_{\text{LL}}$$

$$V_{RNL} = V_S / A = 196.2 / 0.9918 = 197.9 \text{ kV}$$

$$\% VR = \frac{197.9 - 218}{218} \times 100 = -9.22\%$$

Next, reworking Prob. 5.16:

$$\bar{Z}_C = \sqrt{\bar{z} / \bar{y}} = \sqrt{j0.335 / j4.807 \times 10^{-6}} = 264 \Omega$$

$$\text{(a) } \bar{\gamma} l = \sqrt{\bar{z} \bar{y} l} = \sqrt{j0.335(j4.807 \times 10^{-6})} (300) = j0.3807 \text{ pu}$$

$$\text{(b) } A = D = \cos \beta l = \cos(0.3807 \text{ radians}) = 0.9284 \text{ pu}$$

$$\bar{B} = j\bar{Z}_C \sin \beta l = j264 \sin(0.3807 \text{ radians}) = j98.1 \Omega$$

$$\bar{C} = j \left( \frac{1}{\bar{Z}_C} \right) \sin \beta l = j \frac{1}{264} \sin(0.3807 \text{ radians}) = j1.408 \times 10^{-3} \text{ S}$$

$$5.30 \quad Z_C = \sqrt{\frac{\bar{Z}}{y}} = \sqrt{\frac{L_1}{C_1}} = \sqrt{\frac{\mu_0 \operatorname{Ln}(D_{eq}/D_{SL})}{2\pi\epsilon_0 / \operatorname{Ln}(D_{eq}/D_{SC})}}$$

$$\bar{Z}_C = \underbrace{\sqrt{\frac{\mu_0}{\epsilon_0}}}_{\substack{\text{Characteristic} \\ \text{impedence of} \\ \text{free space}}} \left[ \frac{\sqrt{\operatorname{Ln}\left(\frac{D_{eq}}{D_{SL}}\right) \operatorname{Ln}\left(\frac{D_{eq}}{D_{SC}}\right)}}{2\pi} \right]_{\substack{\text{Geometric factors}}}$$

$$\text{where } \sqrt{\frac{\mu_0}{\epsilon_0}} = \sqrt{\frac{4\pi \times 10^{-7}}{\left(\frac{1}{36\pi}\right) \times 10^{-9}}} = 377 \Omega$$

$$\omega = \sqrt{\frac{1}{L_1 C_1}} = \sqrt{\frac{1}{\frac{\mu_0 \operatorname{Ln}(D_{eq}/D_{SL})}{2\pi} \frac{2\pi\epsilon_0 / \operatorname{Ln}(D_{eq}/D_{SC})}{1}}}$$

$$\omega = \underbrace{\left(\frac{1}{\sqrt{\mu_0 \epsilon_0}}\right)}_{\substack{\text{Free space} \\ \text{velocity of} \\ \text{propagation}}} \left( \frac{\sqrt{\operatorname{Ln}(D_{eq}/D_{SC})}}{\sqrt{\operatorname{Ln}(D_{eq}/D_{SL})}} \right)_{\substack{\text{Geometric factors}}}$$

$$\text{where } \sqrt{\frac{1}{\mu_0 \epsilon_0}} = \sqrt{\frac{1}{(4\pi \times 10^{-7}) \left(\frac{1}{36\pi}\right) \times 10^{-9}}} = 3.0 \times 10^8 \frac{\text{m}}{\text{s}}$$

For the 765 kV line in Example 5.10,

$$D_{eq} = \sqrt[3]{(14)(14)(28)} = 17.64 \text{ m}$$

$$D_{SL} = 1.0914 \sqrt[4]{\left(\frac{.0403}{3.28}\right) (0.457)^3} = 0.202 \text{ m}$$

$$D_{SC} = 1.0914 \sqrt[4]{\left(\frac{1.196}{2}\right) (.0254)(0.457)^3} = 0.213 \text{ m}$$

$$Z_C = 377 \left[ \frac{\sqrt{\operatorname{Ln}\left(\frac{17.64}{0.202}\right) \operatorname{Ln}\left(\frac{17.64}{0.213}\right)}}{2\pi} \right] = \underline{\underline{267 \Omega}}$$

$$\omega = 3 \times 10^8 \sqrt{\frac{\operatorname{Ln}(17.64/.213)}{\operatorname{Ln}(17.64/.202)}} = \underline{\underline{2.98 \times 10^8 \frac{\text{m}}{\text{s}}}}$$

5.31 (a) For a lossless line,  $\beta = \omega\sqrt{LC} = 2\pi(60)\sqrt{0.97 \times 0.0115 \times 10^{-9}}$   
 $= 0.001259 \text{ rad/km}$

$$\bar{Z}_C = \sqrt{L/C} = \sqrt{\frac{0.97 \times 10^{-3}}{0.0115 \times 10^{-6}}} = 290.43 \Omega$$

Velocity of propagation  $v = \frac{1}{\sqrt{LC}} = \frac{1}{\sqrt{0.97 \times 0.0115 \times 10^{-9}}} = 2.994 \times 10^5 \text{ km/s}$

and the line wave length is  $\lambda = v/f = \frac{1}{60}(2.994 \times 10^3) = 4990 \text{ km}$

(b)  $\bar{V}_R = \frac{500}{\sqrt{3}} \angle 0^\circ \text{ kV} = 288.675 \angle 0^\circ \text{ kV}$

$$\bar{S}_{R(3\phi)} = \frac{800}{0.8} \angle \cos^{-1} 0.8 = 800 + j600 \text{ MVA} = 1000 \angle 36.87^\circ \text{ MVA}$$

$$\bar{I}_R = S_{R(3\phi)}^* / 3\bar{V}_R^* = \frac{(1000 \angle -36.87^\circ) 10^3}{3 \times 288.675 \angle 0^\circ} = 1154.7 \angle -36.87^\circ \text{ A}$$

Sending end voltage  $\bar{V}_S = \cos \beta l \bar{V}_R + j\bar{Z}_C \sin \beta l \bar{I}_R$

$$\beta l = 0.001259 \times 300 = 0.3777 \text{ rad} = 21.641^\circ$$

$$\therefore \bar{V}_S = 0.9295(288.675 \angle 0^\circ) + j(290.43)0.3688(1154.7 \angle -36.87^\circ)(10^{-3})$$

$$= 356.53 \angle 16.1^\circ \text{ kV}$$

Sending end line-to-line voltage magnitude  $= \sqrt{3} 356.53$   
 $= 617.53 \text{ kV}$

$$\bar{I}_S = j \frac{1}{\bar{Z}_C} \sin \beta l \bar{V}_R + \cos \beta l \bar{I}_R$$

$$= j \frac{1}{290.43} 0.3688(288.675 \angle 0^\circ) 10^3 + 0.9295(1154.7 \angle -36.87^\circ)$$

$$= 902.3 \angle -17.9^\circ \text{ A}; \text{ Line current} = 902.3 \text{ A}$$

$$\bar{S}_{S(3\phi)} = 3\bar{V}_S \bar{I}_S^* = 3(356.53 \angle 16.1^\circ)(902.3 \angle -17.9^\circ) 10^{-3}$$

$$= 800 \text{ MW} + j539.672 \text{ MVAR}$$

$$\text{Percent voltage regulation} = \frac{(356.53/0.9295) - 288.675}{288.675} \times 100$$

$$= 32.87\%$$

5.32 (a) The line phase constant is  $\beta l = \frac{2\pi}{\lambda} l_{rad} = \frac{360}{\lambda} l = \frac{360}{3000} 315$   
 $= 22.68^\circ$

From the practical line loadability,

$$P_{3\phi} = \frac{V_S \text{ pu } V_R \text{ pu } (SIL)}{\sin \beta l} \sin \delta; \quad 700 = \frac{(1.0)(0.9)(SIL)}{\sin 22.68^\circ} \sin 36.87^\circ$$

$$\therefore SIL = 499.83 \text{ MW}$$

$$\text{Since } SIL = \frac{(kV_{L \text{ rated}})^2}{Z_c} \text{ MW, } kV_L = \sqrt{Z_c (SIL)} = \sqrt{(320)(499.83)}$$

$$= 400 \text{ kV}$$

(b) The equivalent line reactance for a lossless line is

$$X' = Z_c \sin \beta l = 320(\sin 22.68^\circ) = 123.39 \Omega$$

For a lossless line, the maximum power that can be transmitted under steady-state condition occurs for a load angle of  $90^\circ$ .

With  $V_S = 1 \text{ pu} = 400 \text{ kV} (L-L)$ ,  $V_R = 0.9 \text{ pu} = 0.9(400) \text{ kV} (L-L)$

$$\text{Theoretical Maximum Power} = \frac{(400)(0.9 \times 400)}{123.39} \times 1$$

$$= 1167 \text{ MW}$$

**5.33** (a)  $\bar{V}_2 = \bar{Z}_c \bar{I}_2$  since the line is terminated in  $\bar{Z}_c$ .

$$\text{Then } \bar{V}_1 = \bar{V}_2 (\cosh \bar{\gamma} l + \sinh \bar{\gamma} l) = \bar{V}_2 e^{\bar{\gamma} l} = \bar{V}_2 e^{\alpha l} e^{j\beta l} \quad (1)$$

$$\bar{I}_1 = \bar{I}_2 (\cosh \bar{\gamma} l + \sinh \bar{\gamma} l) = \bar{I}_2 e^{\bar{\gamma} l} = \bar{I}_2 e^{\alpha l} e^{j\beta l} \quad (2)$$

$$\therefore \frac{\bar{V}_1}{\bar{I}_1} = \frac{\bar{V}_2}{\bar{I}_2} = \bar{Z}_c \quad \leftarrow \quad (\text{Note: } \bar{\gamma} = \alpha + j\beta)$$

$$(b) \quad V_1 = |\bar{V}_1| = V_2 e^{\alpha l} \quad \text{or} \quad \frac{V_2}{V_1} = e^{-\alpha l} \quad \text{From (1) } \leftarrow$$

$$(c) \quad \frac{I_2}{I_1} = e^{-\alpha l} \quad \text{From (2) } \leftarrow$$

$$(d) \quad -\bar{S}_{21} = \bar{V}_2 \bar{I}_2^* = \bar{V}_1 e^{-\alpha l} e^{-j\beta l} \bar{I}_1^* e^{-\alpha l} e^{j\beta l}$$

$$= \bar{S}_{12} e^{-2\alpha l}$$

$$\text{Thus } -\frac{\bar{S}_{21}}{\bar{S}_{12}} = e^{-2\alpha l} \quad \leftarrow$$

which is  $(I_2^2 / I_1^2)$ .

(e) Noting that  $\alpha$  is real,

$$\eta = \frac{-P_{21}}{P_{12}} = e^{-2\alpha l} \quad \leftarrow$$



**5.34** For a lossless line,  $\bar{Z}_C = \sqrt{\frac{L}{C}}$ , Eq. (5.4.3) of text which is pure real, i.e. resistive.

$\bar{\gamma} = j\beta$  is pure imaginary;  $\beta = \omega\sqrt{LC}$ ;  $\alpha = 0$

$$\therefore \frac{V_2}{V_1} = \frac{I_2}{I_1} = \frac{-\bar{S}_{21}}{\bar{S}_{12}} = \frac{-P_{21}}{P_{12}} = \eta = 1$$

$P_{12} = \text{Re}(\bar{V}_1 \bar{I}_1^*) = \text{Re} \bar{Z}_C I_1^2 = \bar{Z}_C I_1^2$  Since  $\bar{Z}_C$  is real.

Since  $\bar{I}_1 = \bar{V}_1 / \bar{Z}_C$ ,  $P_{12} = V_1^2 / \bar{Z}_C \leftarrow$

**5.35** Open circuited  $\Rightarrow \bar{I}_2 = 0$ ; Lossless  $\Rightarrow \alpha = 0$ ;  $\bar{\gamma} = j\beta$ .

Short line:  $\bar{V}_1 = \bar{V}_2$

$$\left. \begin{aligned} \text{Medium Line: Nominal } \pi: \bar{V}_1 &= \left(1 + \frac{\bar{Z}\bar{Y}}{2}\right) \bar{V}_2 = \left(1 + \frac{(\bar{\gamma}l)^2}{2}\right) \bar{V}_2 \\ &= \left[1 - \frac{(\beta l)^2}{2}\right] \bar{V}_2 \\ \text{Long Line: Equiv. } \pi: \bar{V}_1 &= \bar{V}_2 \cosh \bar{\gamma}l = V_2 \cos \beta l \end{aligned} \right\} \leftarrow$$

Note: The first two terms in the series expansion of

$$\cos \beta l \text{ are } 1 - \frac{(\beta l)^2}{2}$$

While  $\bar{V}_1 = \bar{V}_2$  in the case of short-line model, the voltage at the open receiving end is higher than that at the sending end, for small  $\beta l$ , for the medium and long-line models.  $\leftarrow$

**5.36** From Problem 5.7 solution, see Eq. (1)

$$V_S^2 = V_R^2 + 2V_R I (R \cos \phi_R + X \sin \phi_R) + I^2 (R^2 + X^2)$$

Using  $P = V_R I \cos \phi_R$  and  $Q = V_R I \sin \phi_R$ , one gets

$$-V_S^2 + V_R^2 + 2PR + 2QX + \frac{1}{V_R^2} (P^2 + Q^2) (R^2 + X^2) = 0 \quad (2)$$

In which only  $P$  and  $Q$  vary.

For maximum power,  $dP/dQ = 0$ :

$$\frac{dP}{dQ} = -\frac{2X + 2QC}{2R + 2PC}, \quad \text{Where } C = \frac{R^2 + X^2}{V_R^2}$$

and for  $\frac{dP}{dQ} = 0$ ,  $Q = -\frac{V_R^2 X}{R^2 + X^2} \leftarrow$

Substituting the above in (2), after some algebraic simplification, one gets

$$P_{MAX} = \frac{V_R^2}{Z^2} \left( \frac{ZV_S}{V_R} - R \right) \leftarrow$$

where  $Z = \sqrt{R^2 + X^2}$ .

**5.37** (a)  $\bar{S}_{12} = \bar{V}_1 \bar{I}_1^* = \bar{V}_1 \left( \frac{\bar{V}_1 - \bar{V}_2}{Z} \right)^* = \frac{V_1^2}{Z^*} - \frac{\bar{V}_1 \bar{V}_2^*}{Z^*}$   
 $= \frac{V_1^2}{Z} e^{j\angle Z} - \frac{V_1 V_2}{Z} e^{j\angle Z} e^{j\theta_2} \leftarrow (1)$

which is the power sent by  $\bar{V}_1$ .

$$\bar{S}_{21} = \frac{V_2^2}{Z} e^{j\angle Z} - \frac{V_2 V_1}{Z} e^{j\angle Z} e^{-j\theta_2}$$

and  $-\bar{S}_{21} = -\frac{V_2^2}{Z} e^{j\angle Z} + \frac{V_2 V_1}{Z} e^{j\angle Z} e^{-j\theta_2} \leftarrow 2$

which is the power received by  $\bar{V}_2$ .

(b)

(i) With  $V_1 = V_2 = 1.0$

$$\left. \begin{aligned} \bar{S}_{12} &= 1\angle 85^\circ - 1\angle 95^\circ = 0.1743 \\ -\bar{S}_{21} &= -1\angle 85^\circ + 1\angle 75^\circ = 0.1717 - j0.0303 \end{aligned} \right\} \leftarrow$$

(ii) With  $V_1 = 1.1$  and  $V_2 = 0.9$

$$\left. \begin{aligned} \bar{S}_{12} &= 1.21\angle 85^\circ - 0.99\angle 95^\circ = 0.1917 + j0.2192 \\ -\bar{S}_{21} &= -0.81\angle 85^\circ + 0.99\angle 75^\circ = 0.1856 + j0.1493 \end{aligned} \right\} \leftarrow$$

Comparing,  $P_{12}$  has not changed much,  
 but  $Q_{12}$  and  $-Q_{21}$  have changed considerably.  $\left. \right\} \leftarrow$

**5.38** From Problem 5.14

$$\bar{A} = 0.8794\angle 0.66^\circ \text{ pu}; \quad A = 0.8794 \text{ and } \theta_A = 0.66^\circ$$

$$\bar{B} = \bar{Z}' = 134.8\angle 85.3^\circ \Omega; \quad Z' = 134.8 \text{ and } \theta_z = 85.3^\circ$$

Using Eq. (5.5.6)

$$P_{R \max} = \frac{500 \times 500}{134.8} - \frac{(0.8794)(500)^2}{134.8} \cos(85.3^\circ - 0.66^\circ)$$

$$= 1854.6 - 152.4 = 1702 \text{ MW (3}\phi\text{)}$$

For this loading at unity power factor,

$$I_R = \frac{P_{R \max}}{\sqrt{3} V_{RLL} (PF)} = \frac{1702}{\sqrt{3} (500) (1.0)} = 1.966 \text{ kA / Phase}$$

From Table A.4, the thermal limit for 3 ACSR 1113 kcmil conductors is  $3 \times 1.11 = 3.33 \text{ kA/p phase}$ . The current 1.966 kA corresponding to the theoretical steady-state stability limit is well below the thermal limit of 3.33 kA.

### 5.39

Line Length		200 km	600 km
$\bar{Z}_C$	$\Omega$	$282.6 \angle -2.45^\circ$	$282.6 \angle -2.45^\circ$
$\bar{\gamma}l$	pu	$0.2486 \angle 87.55^\circ$	$0.7459 \angle 87.55^\circ$
$\bar{A} = \bar{D}$	pu	$0.9694 \angle 0.1544^\circ$	$0.7356 \angle 1.685^\circ$
$\bar{B}$	$\Omega$	$69.54 \angle 85.15^\circ$	$191.8 \angle 85.57^\circ$
$\bar{C}$	S	$8.71 \times 10^{-4} \angle 90.05^\circ$	$2.403 \times 10^{-3} \angle 90.47^\circ$
$P_{R \max}$	MW	3291	1201

The thermal limit of 3.33 kA/phase corresponds to  $\sqrt{3} (500) 3.33 = 2884 \text{ MW}$  at 500 kV and unity power factor.

**5.40**  $\bar{A} = 0.9285 \angle 0.258^\circ \text{ pu}; A = 0.9285, \theta_A = 0.258^\circ$

$\bar{B} = \bar{Z}' = 98.25 \angle 86.69^\circ \Omega; Z' = 98.25, \theta_z = 86.69^\circ$

(a) Using Eq. (5.5.6)

$$P_{R \max} = \frac{500 \times 500}{98.25} - \frac{0.9285(500)^2}{98.25} \cos(86.69^\circ - 0.258^\circ)$$

$$= 2544.5 - 147 = 2397.5 \text{ MW}$$

(b) Using Eq. (5.5.4) with  $\delta = \theta_z$ :

$$Q_R = \frac{-AV_R^2}{Z'} \sin(\theta_z - \theta_A) = \frac{-0.9285(500)^2}{98.25} \sin(86.69^\circ - 0.258^\circ)$$

$$Q_R = -2358 \text{ MVAR Delivered to receiving end}$$

$$Q_R = +2358 \text{ MVAR Absorbed by line at the receiving end}$$

$$\text{Receiving end } pf = \cos\left(\tan^{-1} \frac{Q_R}{P_R}\right) = \cos\left[\tan^{-1} \frac{2358}{2397.5}\right]$$

$$= 0.713 \text{ Leading}$$

$$5.41 \quad (a) \quad \bar{Z} = \bar{z}l = (0.088 + j0.465)100 = 8.8 + j46.5 \Omega$$

$$\frac{\bar{Y}}{2} = \frac{\bar{y}l}{2} = (j3.524 \times 10^{-6})100/2 = j0.1762 \text{ mS}$$

$$\bar{Z}_{base} = V_{L,base}^2 / S_{3\phi,base} = \frac{(230)^2}{100} = 529 \Omega$$

$$\therefore \bar{Z} = (8.8 + j46.5) / 529 = 0.0166 + j0.088 \text{ pu}$$

$$\frac{\bar{Y}}{2} = j0.1762 / (1/0.529) = j0.09321 \text{ pu}$$

The nominal  $\pi$  circuit for the medium line is shown below:

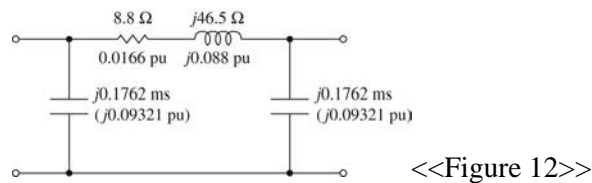

$$(b) \quad S_{3\phi, rated} = V_{L, rated} I_{L, rated} \sqrt{3} = 230(0.9)\sqrt{3} = 358.5 \text{ MVA}$$

$$(c) \quad \bar{A} = \bar{D} = 1 + \frac{\bar{Z}\bar{Y}}{2} = 1 + (8.8 + j46.5)(0.1762 \times 10^{-3}) = 0.9918 \angle 0.1^\circ$$

$$\bar{B} = \bar{Z} = 8.8 + j46.5 = 47.32 \angle 79.3^\circ \Omega$$

$$\bar{C} = \bar{Y} + \frac{\bar{Z}\bar{Y}^2}{4} = 0.1755 \angle 90.04^\circ \text{ mS}$$

$$(d) \quad SIL = V_{L, rated}^2 / \bar{Z}_C$$

$$\bar{Z}_C = \sqrt{\frac{\bar{Z}}{\bar{Y}}} = \sqrt{\frac{0.088 + j0.465}{j3.524}} \times 10^3 = 366.6 \angle -5.36^\circ \Omega$$

$$\therefore SIL = (230)^2 / 366.6 = 144.3 \text{ MVA}$$

$$5.42 \quad \beta l = \frac{2\pi}{\lambda} l \text{ radians} = \left( \frac{360}{\lambda} l \right) = \frac{360}{5000} (500) = 36^\circ$$

Using Eq. (5.4.29) of the text,

$$\begin{aligned} 460 &= \frac{1.0 \times 0.9 (SIL)}{\sin 36^\circ} \sin 36.87^\circ \\ &= \frac{1 \times 0.9 \times SIL}{0.5878} (0.6) \end{aligned}$$

From which  $SIL = 500.7 \text{ MW}$

From Eq. (5.4.21) of the text,

$$V_{L-L} = \sqrt{(\bar{Z}_C) SIL} = \sqrt{(500.7) 500} = 500.3 \text{ kV}$$

Nominal voltage level for the transmission line is

$$500 \text{ kV} \leftarrow$$

For  $\Delta$  loss less line,  $X' = Z_C \sin \beta l$

$$= 500 \sin 36^\circ = 293.9 \Omega$$

From Eq. (5.4.27) of the text,

$$P_{3\phi \max} = \frac{(500)(0.9 \times 500)}{293.9} = 765.6 \text{ MW} \leftarrow$$

- 5.43** The maximum amount of real power that can be transferred to the load at unity pf with a bus voltage greater than 0.9 pu (688.5 kV) is 2950 MW.

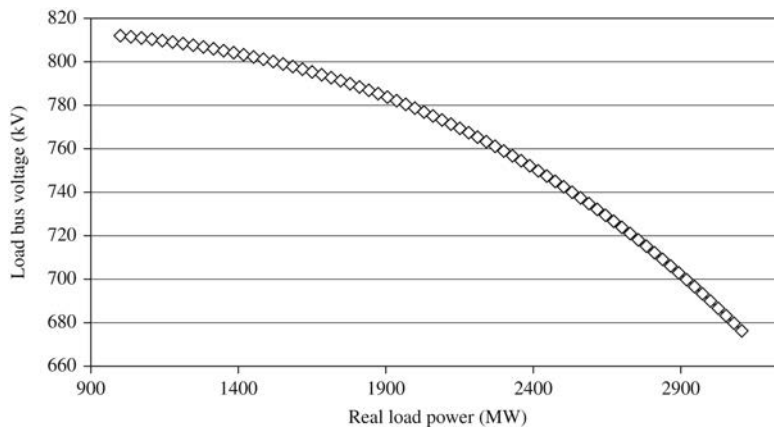

- 5.44** The maximum amount of reactive power transfer that can be transferred to the load with a bus voltage greater than 0.9 pu is 650 Mvar.

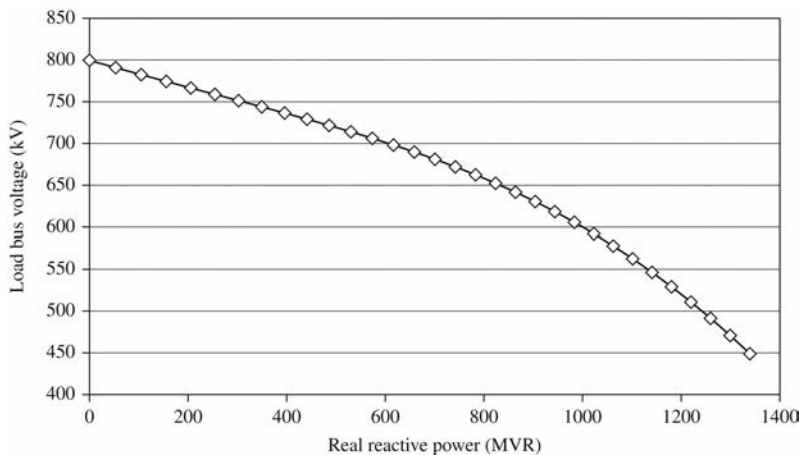

- 5.45** (a) Using Eq. (5.5.3) with  $\delta = 35^\circ$

$$P_R = \frac{(500)(0.95 \times 500)}{134.8} \cos(85.3^\circ - 35^\circ) - \frac{(0.8794)(0.95 \times 500)^2}{134.8} \cos(85.3^\circ - 0.66^\circ)$$

$$= 1125.4 - 137.5 = 987.9 \text{ MW (3}\phi\text{)}$$

$P_R = 988 \text{ MW}$  is the practical line loadability provided that the voltage drop limit and thermal limits are not exceeded.

$$(b) I_{RFL} = \frac{P_R}{\sqrt{3} V_{RLL} (PF)} = \frac{987.9}{\sqrt{3} (0.95 \times 500)(0.99)} = 1.213 \text{ kA}$$

$$(c) \bar{V}_S = \bar{A}\bar{V}_{RFL} + \bar{B}\bar{I}_{RFL}$$

$$\frac{500}{\sqrt{3}} \angle \delta = (0.8794 \angle 0.66^\circ)(V_{RFL} \angle 0^\circ) + (134.8 \angle 85.3^\circ)(1.213 \angle 8.109^\circ)$$

$$288.68 \angle \delta = 0.8794 V_{RFL} \angle 0.66^\circ + 163.5 \angle 93.41^\circ$$

$$288.68 \angle \delta = (0.8793 V_{RFL} - 9.725) + j(0.01013 V_{RFL} + 163.21)$$

Taking the squared magnitude of the above equation:

$$83333 = 0.7733 V_{RFL}^2 - 13.8 V_{RFL} + 26732$$

Solving the above quadratic equation:

$$V_{RFL} = \frac{13.8 + \sqrt{(13.8)^2 + 4(0.7733)(56601)}}{2(0.7733)} = 279.6 \text{ kV}_{L-N}$$

$$V_{RFL} = 279.6 \sqrt{3} = 484.3 \text{ kV}_{L-L} = 0.969 \text{ pu}$$

$$(d) V_{RNL} = V_S / A = 500 / 0.8794 = 568.6 \text{ kV}_{L-L}$$

$$\% VR = \frac{568.6 - 484.3}{484.3} \times 100 = 17\%$$

- (e) From Problem 5.38, thermal limit is 3.33 kA. Since  $V_{RFL} / V_S = 484.3 / 500 = 0.969 > 0.95$ , and the thermal limit of 3.33 kA is greater than 1.213 kA, the voltage drop it and thermal limits are not exceeded at  $P_R = 987.9 \text{ MW}$ . Therefore, loadability is determined by stability.

**5.46**  $\bar{A} = 0.9739 \angle 0.0912^\circ \text{ pu}$ ;  $A = 0.9739$ ,  $\theta_A = 0.0912^\circ$

$$\bar{B} = \bar{Z} = 60.48 \angle 86.6^\circ \Omega$$
;  $Z = 60.48$ ,  $\theta_Z = 86.6^\circ$

- (a) Using Eq. (5.5.3) with  $\delta = 35^\circ$ :

$$P_R = \frac{500(0.95 \times 500)}{60.48} \cos(86.6^\circ - 35^\circ) - \frac{0.9739(0.95 \times 500)^2}{60.48} \cos(86.6^\circ - 0.0912^\circ)$$

$$= 2439.2 - 221.2 = 2218 \text{ MW} (3\phi)$$

$P_R = 2218 \text{ MW}$  is the line loadability if the voltage drop and thermal limits are not exceeded.

$$(b) I_{RFL} = \frac{P_R}{\sqrt{3} V_{RLL} (pf)} = \frac{2218}{\sqrt{3} (0.95 \times 500)(0.99)} = 2.723 \text{ kA}$$

$$(c) \bar{V}_S = \bar{A}\bar{V}_R + \bar{B}\bar{I}_R$$

$$\frac{500}{\sqrt{3}} \angle \delta = (0.9739 \angle 0.0912^\circ) V_{RFL} \angle 0^\circ + 60.48 \angle 86.6^\circ (2.723 \angle 8.11^\circ)$$

$$288.68 \angle \delta = (0.9739 V_{RFL} - 13.55) + j(0.0016 V_{RFL} + 164.14)$$

Taking the squared magnitude of the above

$$83,333 = 0.93664 V_{RFL}^2 - 25.6 V_{RFL} + 27,126$$

Solving the above quadratic equation:

$$V_{RFL} = \frac{25.60 + \sqrt{(25.60)^2 + 4(0.93664)(56,207)}}{2(0.9678)} = 250.68 \text{ kV}_{LN}$$

$V_{RFL} = 250.68 \sqrt{3} = 434.18 \text{ kV}_{LL} = 0.868$  per unit for this load current, 2.723 kA, the voltage drop limit  $V_R / V_S = 0.95$  is exceeded. The thermal limit, 3.33 kA is not exceeded. Therefore the voltage drop limit determines loadability for this line. Based on  $V_{RFL} = .95$  per unit,  $I_{RFL}$  is calculated as follows:

$$\bar{V}_S = \bar{A} \bar{V}_{RFL} + \bar{B} \bar{I}_{RFL}$$

$$\frac{500}{\sqrt{3}} \angle \delta = (0.9739 \angle 0.0912^\circ) \left( \frac{0.95 \times 500}{\sqrt{3}} \angle 0^\circ \right) + 60.48 \angle 86.6^\circ (I_{RFL} \angle 8.11^\circ)$$

$$288.68 \angle \delta = 267.09 \angle 0.0912^\circ + 60.48 I_{RFL} \angle 94.71^\circ$$

$$= (-4.966 I_{RFL} + 267.09) + j(60.28 I_{RFL} + 0.4251)$$

Taking squared magnitudes;

$$83,333 = 3658 I_{RFL}^2 - 2601 I_{RFL} + 71,337$$

Solving the quadratic:

$$I_{RFL} = \frac{2601 + \sqrt{(2601)^2 + 4(3658)(11,996)}}{2(3658)} = 2.2 \text{ kA}$$

At 0.99 pf leading, the practical line loadability for the line is

$$P_R = \sqrt{3} (0.95 \times 500) 2.2 (0.99) = 1792 \text{ MW}$$

which is based on the voltage drop limit  $V_R / V_S = 0.95$ .

(d)  $V_{RNL} = V_S / A = 500 / 0.9739 = 513.4 \text{ kV}_{LL}$

$$\% VR = \frac{513.4 (500 \times 0.95)}{500 \times 0.95} \times 100 = 8.08\%$$

5.47 (a)  $l = 200\text{ km}$ ; The steady-state limit is:

$$P_R = \frac{500(0.95 \times 500)}{69.54} \cos(86.15^\circ - 35^\circ) - \frac{0.9694(0.95 \times 500)^2}{69.54} \cos(85.14^\circ - 0.154^\circ)$$

$$= 1914 \text{ MW}$$

$$I_{RFL} = \frac{P_R}{\sqrt{3} V_{RFL} (PF)} = \frac{1914}{\sqrt{3} (0.95 \times 500) (0.99)} = 2.35 \text{ kA}$$

$$\bar{V}_S = \bar{A}\bar{V}_{RFL} + \bar{B}\bar{I}_{RFL}$$

$$\frac{500}{\sqrt{3}} \angle \delta = (0.9694 \angle 0.154^\circ)(V_{RFL} \angle 0^\circ) + (69.54 \angle 85.15^\circ)(2.35 \angle 8.109^\circ)$$

$$288.675 \angle \delta = (0.9694 V_{RFL} - 9.29) + j(0.0026 V_{RFL} + 163.1)$$

Taking the squared magnitude:

$$83333. = 0.9397 V_{RFL}^2 - 17.16 V_{RFL} + 26707$$

Solving

$$V_{RFL} = \frac{17.16 + \sqrt{(17.16)^2 + 4(0.9397)(56626)}}{2(0.9397)} = 254.8 \text{ kV}_{L-N}$$

$$V_{RFL} = 254.8\sqrt{3} = 441.3 \text{ kV}_{L-L} = 0.8825 \text{ pu}$$

The voltage drop limit  $|V_{RFL}/V_S| \geq 0.95$  is not satisfied.

At the voltage drop limit:

$$\bar{V}_S = \bar{A}\bar{V}_{RFL} + \bar{B}\bar{I}_{RFL}$$

$$\frac{500}{\sqrt{3}} \angle \delta = (0.9694 \angle 0.154^\circ) \left( \frac{0.95 \times 500}{\sqrt{3}} \angle 0^\circ \right) + (69.54 \angle 85.15^\circ)(I_{RFL} \angle 8.109^\circ)$$

$$288.675 \angle \delta = (265.85 - 3.953 I_{RFL}) + j(0.715 + 69.4 I_{RFL})$$

$$83333 = 70677 - 2003 I_{RFL} + 4836 I_{RFL}^2$$

$$I_{RFL} = \frac{2003 + \sqrt{(2003)^2 + 4(4836)(12656)}}{2(4836)} = 1.84 \text{ kA}$$

The practical line loadability for this 200-km line is

$$P_{RFL} = \sqrt{3} (0.95 \times 500) 1.84 (0.99) = 1499 \text{ MW}$$

at  $V_{RFL}/V_S = 0.95\text{ pu}$  and at 0.99 pf leading.



(b)  $l = 600 \text{ km}$

$$P_R = \frac{500(0.95 \times 500)}{191.8} \cos(85.57^\circ - 35^\circ) - \frac{0.7356(0.95 \times 500)^2}{191.8} \cos(85.57^\circ - 1.685^\circ)$$

$$= 786.5 - 92.3 = 694.2 \text{ MW}$$

The practical line loadability is 694.2 MW corresponding to steady-state stability for the 600-km line.

**5.48** (a)  $SIL = (345)^2 / 300 = 396.8 \text{ MW}$

Neglecting losses and using Eq. (5.4.29)

$$P = \frac{1 \times 0.95(SIL) \sin 35^\circ}{\sin\left(\frac{2\pi(300)}{5000} \text{ radians}\right)} = 1.48(SIL) = 1.48(396.8) = 587.3 \text{ MW/line}$$

$$\text{Number of 345-kV lines} = \frac{2000}{587.3} + 1 = 3.4 + 1 \approx 5 \text{ Lines}$$

(b) For 500-kV lines,  $SIL = \frac{(500)^2}{275} = 909.1 \text{ MW}$

$$P = 1.48(SIL) = 1.48 \times 909.1 = 1345.6 \text{ MW/ Line}$$

$$\text{Number of 500-kV Lines} = \frac{2000}{1345.6} + 1 = 1.49 + 1 \approx 3 \text{ Lines}$$

(c) For 765-kV lines,  $SIL = \frac{(765)^2}{260} = 2250.9 \text{ MW}$

$$P = 1.48(SIL) = 1.48 \times 2250.9 = 3331.3 \text{ MW/ Line}$$

$$\text{Number of 765-kV lines} = \frac{2200}{3331.3} + 1 = 0.6 + 1 \approx 2 \text{ Lines}$$

**5.49** (a) Using Eq. (5.4.29):

$$P = \frac{1 \times 0.95(SIL) \sin 35^\circ}{\sin\left(\frac{2\pi(300)}{5000} \text{ radians}\right)} = 1.48(SIL)$$

$$P = 1.48(396.8) = 587.3 \text{ MW / 345 - kV Line}$$

$$\#345\text{-kV Lines} = \frac{3200}{587.3} + 1 = 5.4 + 1 \approx 7 \text{ Lines}$$

$$P = 1.48(909.1) = 1345.5 \text{ MW / 500 - kV Line}$$

$$\#500\text{-kV Lines} = \frac{3200}{1345.5} + 1 = 2.4 + 1 \approx 4 \text{ Lines}$$

$$P = 1.48(2250.9) = 3331.3 \text{ MW / 765 - kV Line}$$

$$\#765\text{-kV Lines} = \frac{3200}{3331.3} + 1 = 0.96 + 1 \approx 2 \text{ Lines}$$

$$(b) P = \frac{(1)(.95)(SIL)(\sin 35^\circ)}{\sin\left(\frac{2\pi \times 400}{5000} \text{ radians}\right)} = 1.131(SIL)$$

$$P = 1.131(396.8) = 448.8 \text{ MW} / 345\text{-kV Line}$$

$$\#345\text{-kV Lines} = \frac{2000}{448.8} + 1 = 4.5 + 1 = \underline{\underline{6 \text{ Lines}}}$$

$$P = (1.131)(909.1) = 1028.3 \text{ MW} / 500\text{kV Line}$$

$$\#500\text{-kV Lines} = \frac{2000}{1028.3} + 1 = 1.94 + 1 = \underline{\underline{3 \text{ Lines}}}$$

$$P = (1.131)(2250.9) = 2545.9 \text{ MW} / 765\text{kV Line}$$

$$\#765\text{-kV Lines} = \frac{2000}{2545.9} + 1 = 0.79 + 1 = \underline{\underline{2 \text{ Lines}}}$$

$$5.50 \quad \beta l = (9.46 \times 10^{-4})(300)(180/\pi) = 16.26^\circ$$

$$\text{Real power for one transmission circuit } P = 3600 / 4 = 900 \text{ MW}$$

$$\text{From the practical line loadability, } P_{3\phi} = \frac{V_{S \text{ pu}} V_{R \text{ pu}} (SIL)}{\sin \beta l} \sin \delta$$

$$\text{or } 900 = \frac{(1.0)(0.9)(SIL)}{\sin 16.26^\circ} \sin(36.87^\circ)$$

$$\text{From which } SIL = 466.66 \text{ MW}$$

$$\text{Since } SIL = \left[ (kV_{L \text{ rated}})^2 / Z_c \right] \text{ MW}$$

$$kV_L = \sqrt{Z_c (SIL)} = \sqrt{(343)(466.66)} = 400 \text{ kV}$$

$$5.51 \quad \text{To show: } P_R + jQ_R = \frac{|\bar{V}_R||\bar{V}_S| \angle \beta - \delta}{|\bar{B}|} - \frac{|A||\bar{V}_R|^2 \angle \beta - \alpha}{|\bar{B}|}$$

(a) The phasor diagram corresponding to the above equation is shown below:

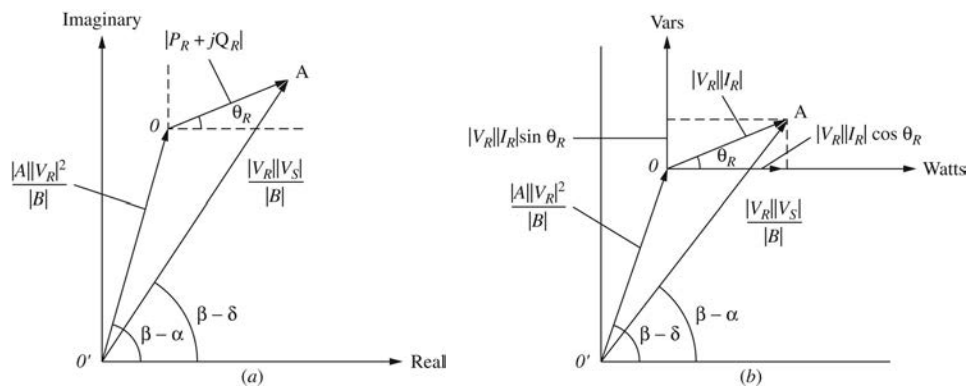

- (b) By shifting the origin from  $O'$  to 0, the power diagram is shown in Fig. (b) above. For a given load and a given value of  $|\bar{V}_R|$ ,  $O'A = |\bar{V}_R| |\bar{V}_S| / |\bar{B}|$  the loci of point A will be a set of circles of radii  $O'A$ , one for each of the set of values of  $|\bar{V}_S|$ . Portions of two such circles (known as receiving-end circles) are shown below:

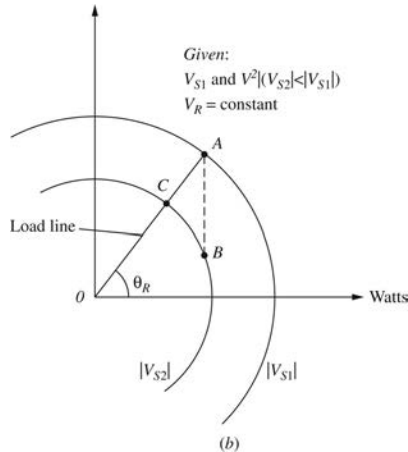

- (c) Line  $OA$  in the figure above is the load line whose intersection with the power circle determines the operating point. Thus, for a load (with a lagging power-factor angle  $\theta_R$ )  $A$  and  $C$  are the operating points corresponding to sending-end voltages  $|\bar{V}_{S1}|$  and  $|\bar{V}_{S2}|$ , respectively. These operating points determine the real and reactive power received for the two sending-end voltages.

The reactive power that must be supplied at the receiving end in order to maintain constant  $|\bar{V}_R|$  when the sending-end voltage decreases from  $|\bar{V}_{S1}|$  to  $|\bar{V}_{S2}|$  is given by  $AB$ , which is parallel to the reactive-power axis.

- 5.52** (a) See Problem 5.37(a) solution: Eqs. (1) and (2) with the substitution of  $\bar{Z}'$  for  $\bar{Z}$ , adding the contribution of the complex power consumed by  $\bar{Y}'/2$ , using Eq. (1) of Problem 5.37(a) solution, one gets

$$\bar{S}_{12} = \frac{\bar{Y}'^*}{2} V_1^2 + \frac{V_1^2}{\bar{Z}^*} - \frac{V_1 V_2}{\bar{Z}^*} e^{j\theta_{12}} \leftarrow$$

Similarly, subtracting the complex power consumed in  $\frac{\bar{Y}'}{2}$  (on the right-hand side in Fig. 5.17),

For the received power, one has

$$-\bar{S}_{21} = -\frac{\bar{Y}'^*}{2} V_2^2 - \frac{V_2^2}{\bar{Z}'^*} + \frac{V_1 V_2}{\bar{Z}'^*} e^{-j\theta_{12}} \leftarrow$$

Except for the additional constant terms, the equations have the same form as those in PR. 5.37.

(b) For a lossless line,  $Z_c = \sqrt{L/C}$  is purely real and  $\bar{\gamma} = j\beta$  is purely imaginary. Also

$$\bar{Y}' = \bar{Y} \frac{\tanh(\bar{\gamma}l/2)}{\bar{\gamma}l/2} = j\omega c \frac{\tan(\beta l/2)}{\beta l/2} \text{ and } \bar{Z}' = \bar{Z}_c \sinh(\bar{\gamma}l)$$

which becomes  $jZ_c \sinh(\beta l)$ .

Note:  $\bar{Y}'$  is now the admittance of a pure capacitance;

$\bar{Z}'$  is now the impedance of a pure inductance.

Active power transmitted,  $P_{12} = -P_{21}$

$$\text{And } P_{12} = \frac{V_1^2 \sin \theta_{12}}{Z_c \sin(\beta l)} \leftarrow$$

Using Eq. (5.4.21) of the text for SIL

$$P_{12} = P_{SIL} \frac{\sin \theta_{12}}{\sin(\beta l)} \leftarrow$$

(c) For  $\beta l = 0.002l$  radians  $= (0.1146l)^\circ$ , and  $\theta_{12} = 45^\circ$ ,

Applying the result of part (b), one gets

$$\frac{P_{12}}{P_{SIL}} = 0.707 \frac{1}{\sin(0.1146l)^\circ} \leftarrow$$

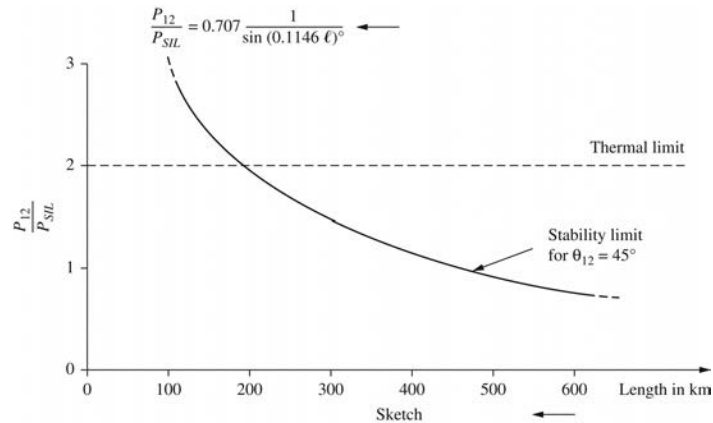

(d) Thermal limit governs the short lines; }  
 Stability limit prevails for long lines. } ←

**5.53** The maximum power that can be delivered to the load is 10,250 MW.

**5.54** For 8800 MW at the load the load bus voltage is maintained above 720 kV even if 2 lines are taken out of service (8850 MW may be OK since the voltage is 719.9 kV).

**5.55** From Problem 5.23, the shunt admittance of the equivalent  $\pi$  circuit without compensation is

$$\bar{Y}' = G' + jB' = 2(1.57 \times 10^{-6} + j8.981 \times 10^{-4}) = (3.14 \times 10^{-6} + j1.796 \times 10^{-3}) \text{ S}$$

With 65% shunt compensation, the equivalent shunt admittance is

$$\begin{aligned} \bar{Y}_{eq} &= 3.14 \times 10^{-6} + j1.796 \left(1 - \frac{65}{100}\right) = 3.14 \times 10^{-6} + j6.287 \times 10^{-4} \\ &= 6.287 \times 10^{-4} \angle 89.71^\circ \text{ S} \end{aligned}$$

Since there is no series compensation

$$\bar{Z}_{eq} = \bar{Z}' = 134.8 \angle 85.3^\circ \Omega$$

The equivalent  $\bar{A}$  parameter of the compensated line is

$$\begin{aligned} \bar{A}_{eq} &= 1 + \frac{\bar{Y}_{eq} \bar{Z}_{eq}}{2} = 1 + \frac{1}{2} (6.287 \times 10^{-4} \angle 89.71^\circ) (134.8 \angle 85.3^\circ) \\ &= 0.9578 \angle 0.22^\circ \text{ pu} \end{aligned}$$

The no-load voltage is

$$V_{RNL} = V_S / A_{eq} = 526.14 / 0.9578 = 549.6 \text{ kV}_{L-L}$$

where  $V_S$  is obtained from Problem 5.15.

$V_{RFL} = 475 \text{ kV}_{L-L}$  is the same as given in Problem 5.15, since the shunt reactors are removed at full load. Therefore

$$\% VR = \frac{V_{RNL} - V_{RFL}}{V_{RFL}} \times 100 = \frac{549.6 - 475}{475} \times 100 = 15.7\%$$

The impedance of each shunt reactor is

$$\begin{aligned} \bar{Z}_{\text{reactor}} &= j \left[ \frac{B'}{2} (0.65) \right]^{-1} = j \left[ \frac{1}{2} \times 1.796 \times 10^{-3} \times 0.65 \right]^{-1} \\ &= j1713 \Omega / \text{phase, at each end of the line.} \end{aligned}$$

**5.56** (a)  $V_S = 653.7 \text{ kV}_{LL}$  (same as Problem 5.17)

$$\begin{aligned} \bar{Y}_{eq} &= 2 \left[ 6.37 \times 10^{-7} + j7.294 \times 10^{-4} (1 - 0.5) \right] \text{ from Problem 5.18} \\ &= 1.274 \times 10^{-6} + j7.294 \times 10^{-4} = 7.294 \times 10^{-4} \angle 87.5^\circ \text{ S} \end{aligned}$$

$$\bar{Z}_{eq} = \bar{Z}' = 98.25 \angle 86.69^\circ \Omega$$

$$\begin{aligned} \bar{A}_{eq} &= 1 + \frac{\bar{Y}_{eq} \bar{Z}_{eq}}{2} = 1 + \frac{1}{2} (7.294 \times 10^{-4} \angle 87.5^\circ) (98.25 \angle 86.69^\circ) \\ &= 1 + 0.0358 \angle 174.19^\circ = 0.9644 + j0.0036 = 0.9644 \angle 0.21^\circ \end{aligned}$$

$$V_{RNL} = V_S / A_{eq} = 653.7 / 0.9644 = 677.8 \text{ kV}_{LL}$$

$$\% VR = \frac{677.8 - 480}{480} \times 100 = 41.2\%$$

(b)  $V_S = 556.7 \text{ kV}_{LL}$  (same as Problem 5.17)

$$V_{RNL} = V_S / A = 556.7 / 0.9644 = 577.3 \text{ kV}_{LL}$$

$$\% VR = \frac{577.3 - 480}{480} \times 100 = 20.3\%$$

(c)  $V_S = 435.1 \text{ kV}_{LL}$  (same as Problem 5.17)

$$V_{RNL} = V_S / A = 435.1 / 0.9644 = 451.2 \text{ kV}_{LL}$$

$$\% VR = \frac{451.2 - 480}{480} \times 100 = -6\%$$

**5.57** From Problem 5.23

$$\bar{Z}' = R' + jX' = (11.0 + j134.3) \Omega$$

Based on 40% series compensation, half at each end of the line, the impedance of each series capacitor is

$$\bar{Z}_{CAP} = -jX_{CAP} = -j \frac{1}{2} (0.4)(134.3) = -j26.86 \Omega / \text{phase (at each end)}$$

Using the  $\overline{ABCD}$  parameters from Problem 5.14, the equivalent  $\overline{ABCD}$  parameters of the compensated line are

$$\left[ \begin{array}{c|c} A_{eq} & B_{eq} \\ \hline C_{eq} & D_{eq} \end{array} \right]_{\text{compensated line}} = \left[ \begin{array}{c|c} 1 & -j26.86 \\ \hline 0 & 1 \end{array} \right]_{\text{Sending-end series capacitors}} \left[ \begin{array}{c|c} 0.8794 \angle 0.66^\circ & 134.8 \angle 85.3^\circ \\ \hline 1.688 \times 10^{-3} \angle 90.2^\circ & 0.8794 \angle 0.66^\circ \end{array} \right]_{\text{uncompensated line}}$$

$$\left[ \begin{array}{c|c} 1 & -j26.86 \\ \hline 0 & 1 \end{array} \right]_{\text{receiving-end series capacitors}}$$

$$\left[ \begin{array}{c|c} A_{eq} & B_{eq} \\ \hline C_{eq} & D_{eq} \end{array} \right] = \left[ \begin{array}{c|c} 0.9248 \angle 0.64^\circ & 86.66 \angle 82.31^\circ \\ \hline 1.688 \angle 90.2^\circ & 0.9248 \angle 0.64^\circ \end{array} \right]$$

**5.58** From Problem 5.16:

(a)  $\bar{Z}' = \bar{B} = 98.25 \angle 86.69^\circ = 5.673 + j98.09 \Omega$

Impedance of each series capacitor is

$$\bar{Z}_{CAP} = -jX_{CAP} = -j \left( \frac{1}{2} \right) 0.3(98.09) = -j14.71 \Omega$$

Equivalent ABCD parameters of the compensated line are

$$\begin{aligned} \begin{bmatrix} \bar{A}_{eq} & \bar{B}_{eq} \\ \bar{C}_{eq} & \bar{D}_{eq} \end{bmatrix} &= \begin{bmatrix} 1 & -j14.71 \\ 0 & 1 \end{bmatrix} \begin{bmatrix} 0.9285 \angle 0.258^\circ & 98.25 \angle 86.69^\circ \\ 1.405 \times 10^{-3} \angle 90.09^\circ & 0.9285 \angle 0.258^\circ \end{bmatrix} \begin{bmatrix} 1 & -j14.71 \\ 0 & 1 \end{bmatrix} \\ &\quad \text{Sending end} \qquad \qquad \qquad \text{Uncompensated line from Pr. 5.13} \qquad \qquad \qquad \text{Receiving end} \\ &\quad \text{series capacitors} \qquad \qquad \qquad \qquad \qquad \qquad \qquad \qquad \qquad \qquad \qquad \text{series capacitors} \\ &= \begin{bmatrix} 1 & -j14.71 \\ 0 & 1 \end{bmatrix} \begin{bmatrix} 0.9285 \angle 0.258^\circ & 84.62 \angle 86.12^\circ \\ 1.405 \times 10^{-3} \angle 90.19^\circ & 0.9492 \angle 0.2535^\circ \end{bmatrix} \\ &= \begin{bmatrix} 0.9492 \angle 0.2553^\circ & 71.45 \angle 80.5^\circ \\ 1.405 \times 10^{-3} \angle 90.09^\circ & 0.9492 \angle 0.2535^\circ \end{bmatrix} \end{aligned}$$

(b)  $A_{eq} = 0.9492$ ,  $\theta_A = 0.2553^\circ$

$B_{eq} = \bar{Z}'_{eq} = 71.45 \Omega$ ,  $\theta_{Z_{eq}} = 80.5^\circ$

From Eq. (5.5.6) with  $V_S = V_R = 500 \text{ kV}_{LL}$

$$\begin{aligned} P_{R_{MAX}} &= \frac{500 \times 500}{71.45} - \frac{(0.9492)(500)^2}{71.45} \cos(80.5^\circ - 0.2553^\circ) \\ &= 3499 - 563 = 2936 \text{ MW} (3\phi) \end{aligned}$$

which is 22.5% larger than the value.

$P_{max} = 2397.5 \text{ MW}$  calculated in Problem 5.40 for the uncompensated line.

**5.59** From Problem 5.57:

$A_{eq} = 0.9248 \text{ pu}$ ;  $\theta_A = 0.64^\circ$

$B_{eq} = \bar{Z}'_{eq} = 86.66 \Omega$ ;  $\theta_{Z_{eq}} = 82.31^\circ$

From Eq. (5.5.6), with  $V_S = V_R = 500 \text{ kV}_{L-L}$

$$\begin{aligned} P_{R_{max}} &= \frac{500 \times 500}{86.66} - \frac{0.9248(500)^2}{86.66} \cos(82.31^\circ - 0.64^\circ) \\ &= 2885 - 387 = 2498 \text{ MW} (3\phi) \end{aligned}$$

which is 46.7% larger than the value  $P_{R_{max}} = 1702 \text{ MW}$  calculated in Problem 5.38 for the uncompensated line.

**5.60** Let  $X_{eq}$  be the equivalent series reactance of one 765-kV, 500 km, series compensated line. The equivalent series reactance of four lines with two intermediate substations and one line section out-of-service is then:

$$\frac{1}{4} \left( \frac{2}{3} X_{eq} \right) + \frac{1}{3} \left( \frac{1}{3} X_{eq} \right) = 0.2778 X_{eq}$$

From Eq. (5.4.26) with  $\delta = 35^\circ$ ,  $V_R = 0.95$  per unit, and  $P = 9000$  MW;

$$P = \frac{(765)(.95 \times 765) \sin(35^\circ)}{.2778 X_{eq}} = 9000.$$

Solving for  $X_{eq}$ :

$$X_{eq} = 127.54 \Omega = X' \left( 1 - \frac{N_C}{100} \right) = 156.35 \left( 1 - \frac{N_C}{100} \right)$$

Solving:  $N_C = 18.4\%$  series capacitive compensation ( $N_C = 21.6\%$  including 4% line losses).

### 5.61

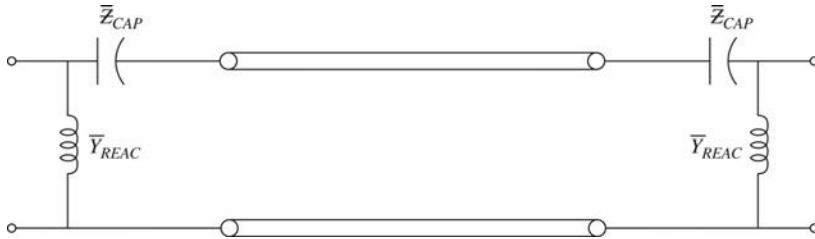

$$\bar{Z}_{CAP} = -j \frac{X'}{2} \left( \frac{N_C}{100} \right) = -j \frac{134.3}{2} \left( \frac{40}{100} \right) = -j26.86 \Omega$$

$$\bar{Y}_{REAC} = -j \frac{B'}{2} \frac{N_L}{100} = -j \frac{8.981 \times 10^{-4}}{2} \left( \frac{65}{100} \right) = -j2.92 \times 10^{-4} \text{ S}$$

$$\begin{bmatrix} \bar{A}_{eq} & \bar{B}_{eq} \\ \bar{C}_{eq} & \bar{D}_{eq} \end{bmatrix} = \begin{bmatrix} 1 & 0 \\ -j2.92 \times 10^{-4} & 1 \end{bmatrix} \begin{bmatrix} 1 & -j26.86 \\ 0 & 1 \end{bmatrix} \begin{bmatrix} 0.8794 \angle 0.66^\circ & 134.8 \angle 85.3^\circ \\ 1.688 \times 10^{-3} \angle 90.2^\circ & 0.8794 \angle 0.66^\circ \end{bmatrix} \times \begin{bmatrix} 1 & -j26.86 \\ 0 & 1 \end{bmatrix} \begin{bmatrix} 1 & 0 \\ -j2.92 \times 10^{-4} & 1 \end{bmatrix}$$

Sending-end shunt compensation      Sending-end series compensation  
 Line  
 Receiving end series compensation      Receiving end shunt compensation

After multiplying the above 5 matrices, the answer can be obtained.



**5.62** See solution of Pr. 5.18 for  $\bar{\gamma}l, \bar{Z}_C, \cosh \bar{\gamma}l$ , and  $\sinh \bar{\gamma}l$ .

For the uncompensated line:

$$\begin{aligned}\bar{A} = \bar{D} &= \cosh \bar{\gamma}l = 0.8904 \angle 1.34^\circ \\ \bar{B} = \bar{Z}' &= \bar{Z}'_C \sinh \bar{\gamma}l = 186.78 \angle 79.46^\circ \Omega \\ \bar{C} &= \frac{\sinh \bar{\gamma}l}{\bar{Z}'_C} = \frac{0.4596 \angle 84.94^\circ}{406.4 \angle -5.48^\circ} = 0.001131 \angle 90.42^\circ \text{ S}\end{aligned}$$

Noting that the series compensation only alters the series arm of the equivalent  $\pi$ -circuit, the new series arm impedance is

$$\bar{Z}'_{new} = \bar{B}_{new} = 186.78 \angle 79.46^\circ - j0.7 \times 230(0.8277) = 60.88 \angle 55.85^\circ \Omega$$

In which 0.8277 is the imaginary part of  $\bar{z} = 0.8431 \angle 79.04^\circ \Omega/\text{mi}$

$$\text{Nothing that } \bar{A} = \frac{\bar{Z}'\bar{Y}'}{2} + 1 \text{ and } \frac{\bar{Y}'}{2} = \frac{1}{\bar{Z}'_C} \frac{\cosh \bar{\gamma}l - 1}{\sinh \bar{\gamma}l} = 0.000399 \angle 89.82^\circ \text{ S}$$

$$\begin{aligned}\bar{A}_{new} &= (60.88 \angle 55.85^\circ \times 0.000599 \angle 89.81^\circ) + 1 = 0.97 \angle 1.24^\circ \\ \bar{C}_{new} &= \bar{Y}' \left( 1 + \frac{\bar{Z}'\bar{Y}'}{4} \right) = \bar{Y}' + \frac{\bar{Z}'\bar{Y}'^2}{4} \\ &= 2 \times 0.000599 \angle 89.81^\circ + 60.88 \angle 55.85^\circ (0.000599 \angle 89.81^\circ)^2 \\ &= 0.00118 \angle 90.41^\circ \text{ S}\end{aligned}$$

The series compensation has reduced the parameter  $\bar{B}$  to about one-third of its value for the uncompensated line, without affecting the  $\bar{A}$  and  $\bar{C}$  parameter appreciably.

Thus, the maximum power that can be transmitted is increased by about 300%.

**5.63** The shunt admittance of the entire line is

$$\bar{Y} = \bar{\gamma}l = -j5.105 \times 10^{-6} \times 230 = -j0.001174 \text{ S}$$

With 70% compensation,  $\bar{Y}_{new} = 0.7 \times (-j0.001174) = -j0.000822 \text{ S}$

From Fig. 5.4 of the text, for the case of 'shunt admittance',

$$A = D = 1; B = 0; \bar{C} = \bar{Y}$$

$$\therefore \bar{C} = \bar{Y}_{new} = -j0.000822 \text{ S}$$

For the uncompensated line, the  $\bar{A}, \bar{B}, \bar{C}, \bar{D}$  parameters are calculated in the solution of Pr. 5.49.

For 'series networks', see Fig.5.4 of the text to modify the parameters. So for the line with a shunt inductor,

$$\begin{aligned}\bar{A}_{eq} &= 0.8904 \angle 1.34^\circ + 186.78 \angle 79.46^\circ (0.000822 \angle -90^\circ) \\ &= 1.0411 \angle -0.4^\circ\end{aligned}$$

The voltage regulation with the shunt reactor connected at no load is given by

$$\frac{(137.86/1.0411) - 124.13}{124.13} = 0.0667$$

which is a considerable reduction compared to 0.247 for the regulation of the uncompensated line. (see solution of Pr. 5.18)

**5.64** (a) From the solution of Pr. 5.31,

$$\bar{Z}_C = 290.43 \Omega; \beta l = 21.641^\circ$$

For a lossless line, the equivalent line reactance is given by

$$X' = \bar{Z}_C \sin \beta l = (290.43) \sin 21.641^\circ = 107.11 \Omega$$

The receiving end power  $\bar{S}_{R(3\phi)} = 1000 \angle \cos^{-1} 0.8 = 800 + j600 \text{ MVA}$

Since  $P_{3\phi} = \frac{V_{S(L-L)} V_{R(L-L)}}{X'} \sin \delta$ , the power angle  $\delta$  is obtained from

$$800 = (500 \times 500 / 107.11) \sin \delta$$

$$\text{or } \delta = 20.044^\circ$$

The receiving end reactive power is given by (approximately)

$$\begin{aligned} Q_{R(3\phi)} &= \frac{V_{S(L-L)} V_{R(L-L)}}{X'} \cos \delta - \frac{V_{R(L-L)}^2}{X'} \cos \beta l \\ &= \frac{500 \times 500}{107.11} \cos(20.044^\circ) - \frac{(500)^2}{107.11} \cos(21.641^\circ) \\ &= 23.15 \text{ MVAR} \end{aligned}$$

Then the required capacitor MVAR is  $\bar{S}_C = j23.15 - j600 = -j576.85$

The capacitive reactance is given by (see Eq. 2.3.5 in text)

$$X_C = \frac{-jV_L^2}{\bar{S}_C} = \frac{-j500^2}{-j576.85} = 433.38 \Omega$$

$$\text{or } C = \frac{10^6}{2\pi(60)433.38} = 6.1 \mu\text{F}$$

(b) For 40% compensation, the series capacitor reactance per phase is

$$X_{ser} = 0.4X' = 0.4(107.1) = 42.84 \Omega$$

The new equivalent  $\pi$ -circuit parameters are given by

$$\bar{Z}' = j(X' - X_{ser}) = j64.26 \Omega; \bar{Y}' = j \frac{2}{\bar{Z}_C} \tan\left(\frac{\beta l}{2}\right) = j0.001316 \text{ S}$$

$$\bar{B}_{new} = j64.26 \Omega; \bar{A}_{new} = 1 + \frac{\bar{Z}' \bar{Y}'}{2} = 0.9577$$

The receiving end voltage per phase  $\bar{V}_R = \frac{500}{\sqrt{3}} \angle 0^\circ \text{ kV} = 288.675 \angle 0^\circ \text{ kV}$

The receiving end current is  $\bar{I}_R = \bar{S}_{R(3\phi)}^* / 3\bar{V}_R^*$

Thus  $\bar{I}_R = \frac{1000 \angle -36.87^\circ}{3 \times 288.675 \angle 0^\circ} = 1.1547 \angle -36.87^\circ \text{ kA}$

The sending end voltage is then given by

$$\bar{V}_S = \bar{A}\bar{V}_R + \bar{B}\bar{I}_R = 326.4 \angle 10.47^\circ \text{ kV}; \quad V_{S(L-L)} = \sqrt{3} 326.4 = 565.4 \text{ kV}$$

$$\text{Percent voltage regulation} = \frac{(565.4 / 0.958) - 500}{500} \times 100 = 18\%$$

- 5.65** The maximum amount of real power which can be transferred to the load at unity pf with a bus voltage greater than 0.9 pu is 3900 MW.

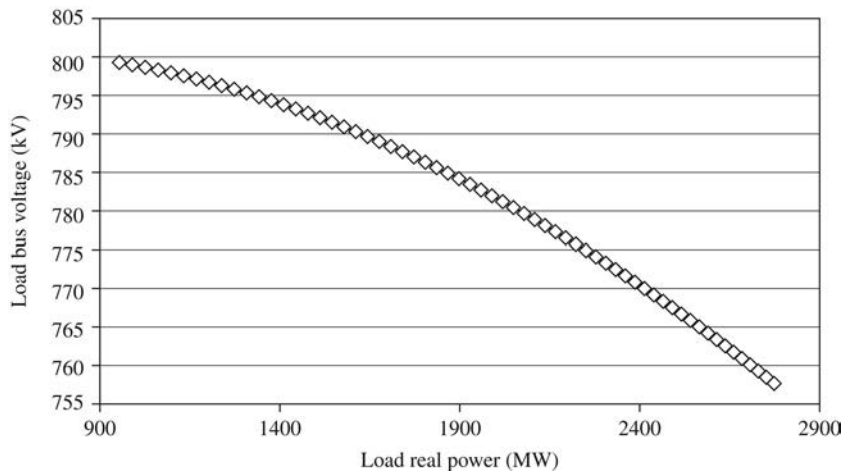

- 5.66** The maximum amount of real power which can be transferred to the load at unity pf with a bus voltage greater than 0.9 pu is 3400 MW (3450 MW may be OK since pu voltage is 0.8985).

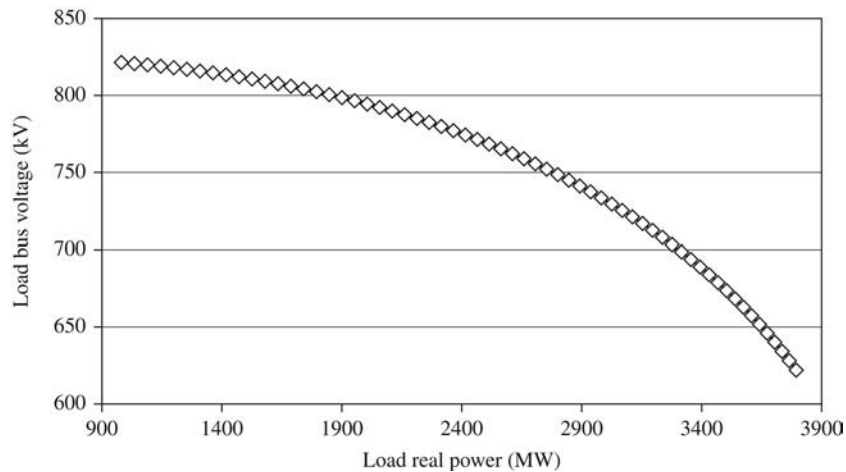

# Chapter 6

## Power Flows

### ANSWERS TO MULTIPLE-CHOICE TYPE QUESTIONS

- 6.1 Nonzero
- 6.2 Upper triangular
- 6.3 Diagonal; lower triangular
- 6.4 b
- 6.5  $\frac{\partial f_1}{\partial x_1} \frac{\partial f_1}{\partial x_2} \dots \frac{\partial f_1}{\partial x_N}$
- 6.6 a
- 6.7 a
- 6.8 Independent
- 6.9  $P_1, Q_1$
- 6.10  $V_k, \delta_k$
- 6.11  $P_k$  &  $V_k; Q_k$  &  $\delta_k$
- 6.12  $-P_{Lk}; -Q_{Lk}$
- 6.13 Bus data, transmission line data, transformer data
- 6.14 a
- 6.15 a
- 6.16 a
- 6.17 Newton-Raphson
- 6.18 Real power, reactive power
- 6.19 Negative
- 6.20 a
- 6.21 Sparse
- 6.22 Storage, time
- 6.23 a
- 6.24 a
- 6.25 a

$$6.1 \quad \begin{bmatrix} -25 & 5 & 10 & 10 \\ 5 & -10 & 5 & 0 \\ 10 & 5 & -10 & 10 \\ 10 & 0 & 0 & -20 \end{bmatrix} \begin{bmatrix} x_1 \\ x_2 \\ x_3 \\ x_4 \end{bmatrix} = \begin{bmatrix} 0 \\ 2 \\ 1 \\ -2 \end{bmatrix}$$

There are  $N - 1 = 3$  Gauss elimination steps.

Step 1: Use equation 1 to eliminate  $x_1$  from equations 2, 3, and 4.

$$\begin{bmatrix} -25 & 5 & 10 & 10 \\ 0 & -9 & 7 & 2 \\ 0 & 7 & -6 & 14 \\ 0 & 2 & 4 & -16 \end{bmatrix} \begin{bmatrix} x_1 \\ x_2 \\ x_3 \\ x_4 \end{bmatrix} = \begin{bmatrix} 0 \\ 2 \\ 1 \\ -2 \end{bmatrix}$$

Step 2: Use equation 2 to eliminate  $x_2$  from equations 3 and 4.

$$\begin{bmatrix} -25 & 5 & 10 & 10 \\ 0 & -9 & 7 & 2 \\ 0 & 0 & \frac{-5}{9} & \frac{140}{9} \\ 0 & 0 & \frac{50}{9} & \frac{-140}{9} \end{bmatrix} \begin{bmatrix} x_1 \\ x_2 \\ x_3 \\ x_4 \end{bmatrix} = \begin{bmatrix} 0 \\ 2 \\ \frac{23}{9} \\ \frac{-14}{9} \end{bmatrix}$$

Step 3: Use equation 3 to eliminate  $x_3$  from equation 4.

$$\begin{bmatrix} -25 & 5 & 10 & 10 \\ 0 & -9 & 7 & 2 \\ 0 & 0 & \frac{-5}{9} & \frac{140}{9} \\ 0 & 0 & 0 & 140 \end{bmatrix} \begin{bmatrix} x_1 \\ x_2 \\ x_3 \\ x_4 \end{bmatrix} = \begin{bmatrix} 0 \\ 2 \\ \frac{23}{9} \\ 24 \end{bmatrix}$$

The matrix is now triangular. Solving via back substitution,

$$x_4 = \frac{6}{35}$$

$$x_3 = \frac{1}{5}$$

$$x_2 = -\frac{1}{35}$$

$$x_1 = \frac{1}{7}$$

$$6.2 \quad \begin{bmatrix} 6 & 2 & 1 \\ 4 & 10 & 2 \\ 3 & 4 & 14 \end{bmatrix} \begin{bmatrix} x_1 \\ x_2 \\ x_3 \end{bmatrix} = \begin{bmatrix} 3 \\ 4 \\ 2 \end{bmatrix}$$

There are  $N - 1 = 2$  Gauss elimination steps.

Step 1: Use equation 1 to eliminate  $x_1$  from equations 2 and 3.

$$\begin{bmatrix} 6 & 2 & 1 \\ 0 & \frac{26}{3} & \frac{4}{3} \\ 0 & 3 & \frac{27}{2} \end{bmatrix} \begin{bmatrix} x_1 \\ x_2 \\ x_3 \end{bmatrix} = \begin{bmatrix} 3 \\ 2 \\ \frac{1}{2} \end{bmatrix}$$

Step 2: Use equation 2 to eliminate  $x_2$  from equation 3.

$$\begin{bmatrix} 6 & 2 & 1 \\ 0 & \frac{26}{3} & \frac{4}{3} \\ 0 & 0 & \frac{339}{26} \end{bmatrix} \begin{bmatrix} x_1 \\ x_2 \\ x_3 \end{bmatrix} = \begin{bmatrix} 3 \\ 2 \\ -\frac{5}{26} \end{bmatrix}$$

The matrix is now triangular. Solving via back substitution,

$$x_3 = -\frac{5}{339}$$

$$x_2 = \frac{79}{339}$$

$$x_1 = \frac{48}{113}$$

**6.3**

$$\begin{bmatrix} 4 & 2 & 1 \\ 4 & 10 & 2 \\ 3 & 4 & 14 \end{bmatrix} \begin{bmatrix} x_1 \\ x_2 \\ x_3 \end{bmatrix} = \begin{bmatrix} 3 \\ 4 \\ 2 \end{bmatrix}$$

There are  $N - 1 = 2$  Gauss elimination steps.

Step 1: Use equation 1 to eliminate  $x_1$  from equations 2 and 3.

$$\begin{bmatrix} 4 & 2 & 1 \\ 0 & 8 & 1 \\ 0 & \frac{5}{2} & \frac{53}{4} \end{bmatrix} \begin{bmatrix} x_1 \\ x_2 \\ x_3 \end{bmatrix} = \begin{bmatrix} 3 \\ 1 \\ -\frac{1}{4} \end{bmatrix}$$

Step 2: Use equation 2 to eliminate  $x_2$  from equation 3.

$$\begin{bmatrix} 4 & 2 & 1 \\ 0 & 8 & 1 \\ 0 & 0 & \frac{207}{16} \end{bmatrix} \begin{bmatrix} x_1 \\ x_2 \\ x_3 \end{bmatrix} = \begin{bmatrix} 3 \\ 1 \\ -\frac{9}{16} \end{bmatrix}$$

The matrix is now triangular. Solving via back substitution,

$$x_3 = -\frac{1}{23}$$

$$x_2 = \frac{3}{23}$$

$$x_1 = \frac{16}{23}$$

**6.4** 
$$\begin{bmatrix} -10 & 10 \\ 5 & -5 \end{bmatrix} \begin{bmatrix} x_1 \\ x_2 \end{bmatrix} = \begin{bmatrix} 10 \\ -10 \end{bmatrix}$$

If we perform Gauss elimination, we arrive at:

$$\begin{bmatrix} -10 & 10 \\ 0 & 0 \end{bmatrix} \begin{bmatrix} x_1 \\ x_2 \end{bmatrix} = \begin{bmatrix} 10 \\ -5 \end{bmatrix}$$

The 2<sup>nd</sup> row says that

$$0x_1 + 0x_2 = -5$$

Clearly, this is not possible.

The problem in this case is that the system we started with is indeterminate. That is,

$$\begin{vmatrix} -10 & 10 \\ 5 & -5 \end{vmatrix} = 0$$

This system has no solution.

**6.5** From Eq. (7.1.6), back substitution is given by:

$$X_k = \frac{y_k - A_{k,k+1}X_{k+1} - A_{k,k+2}X_{k+2} \cdots - A_{k,N}X_N}{A_{kk}}$$

which requires one division,  $(N - k)$  multiplications and  $(N - k)$  subtractions for each  $k = N, (N - 1) \cdots 1$ .

### **Summary- Back Substitution**

<b>Solving for</b>	<b># Divisions</b>	<b># Multiplications</b>	<b># Subtractions</b>
$X_N$	1	0	0
$X_{N-1}$	1	1	1
$X_{N-2}$	1	2	2
$\vdots$			
$X_1$	1	$(N-1)$	$(N-1)$
<b>Totals</b>	$N$	$\sum_{i=1}^{N-1} i = \frac{N(N-1)}{2}$	$\sum_{i=1}^{N-1} i = \frac{N(N-1)}{2}$

$$6.6 \quad D = \begin{bmatrix} 6 & 0 & 0 \\ 0 & 10 & 0 \\ 0 & 0 & 14 \end{bmatrix} \quad M = D^{-1}(D - A) = \begin{bmatrix} 0 & -0.3333 & -0.1667 \\ -0.4 & 0 & -0.2 \\ -0.2143 & -0.2857 & 0 \end{bmatrix}$$

$$\bar{x}(i+1) = M\bar{x}(i) + D^{-1}B$$

$$x_1 = 0.4243 \quad x_2 = 0.2325 \quad x_3 = -0.0152 \text{ after 10 iterations}$$

$$6.7 \quad D = \begin{bmatrix} 6 & 0 & 0 \\ 4 & 10 & 0 \\ 3 & 4 & 14 \end{bmatrix} \quad M = D^{-1}(D - A) = \begin{bmatrix} 0 & -0.3333 & -0.1667 \\ 0 & 0.1333 & -0.1333 \\ 0 & 0.0333 & 0.0738 \end{bmatrix}$$

$$\bar{x}(i+1) = M\bar{x}(i) + D^{-1}B$$

$$x_1 = 0.4249 \quad x_2 = 0.2330 \quad x_3 = -0.0148 \text{ after 4 iterations}$$

The Gauss-Seidel method converges over twice as fast as the Jacobi method.

$$6.8 \quad \begin{bmatrix} 10 & -2 & -4 \\ -2 & 6 & -2 \\ -4 & -2 & 10 \end{bmatrix} \begin{bmatrix} x_1 \\ x_2 \\ x_3 \end{bmatrix} = \begin{bmatrix} -2 \\ 3 \\ -1 \end{bmatrix}$$

$$D = \begin{bmatrix} 10 & 0 & 0 \\ 0 & 6 & 0 \\ 0 & 0 & 10 \end{bmatrix} \quad D^{-1} = \begin{bmatrix} \frac{1}{10} & 0 & 0 \\ 0 & \frac{1}{6} & 0 \\ 0 & 0 & \frac{1}{10} \end{bmatrix}$$

$$M = D^{-1}(D - A) = \begin{bmatrix} 0 & \frac{1}{5} & \frac{2}{5} \\ \frac{1}{3} & 0 & \frac{1}{3} \\ \frac{2}{5} & \frac{1}{5} & 0 \end{bmatrix}$$

Expressing in the form of Eq. (6.2.6)

$$\begin{bmatrix} x_1(i+1) \\ x_2(i+1) \\ x_3(i+1) \end{bmatrix} = \begin{bmatrix} 0 & \frac{1}{5} & \frac{2}{5} \\ \frac{1}{3} & 0 & \frac{1}{3} \\ \frac{2}{5} & \frac{1}{5} & 0 \end{bmatrix} \begin{bmatrix} x_1(i) \\ x_2(i) \\ x_3(i) \end{bmatrix} + \begin{bmatrix} \frac{1}{10} & 0 & 0 \\ 0 & \frac{1}{6} & 0 \\ 0 & 0 & \frac{1}{10} \end{bmatrix} \begin{bmatrix} -2 \\ 3 \\ -1 \end{bmatrix}$$



Using

$$x(0) = \begin{bmatrix} 1 \\ 1 \\ 0 \end{bmatrix}$$

we arrive at the following table:

$i$	0	1	2	3	4	5	6	7	8	9	10
$x_1$	1	0	0.1667	-0.04	-0.0444	-0.0962	-0.1085	-0.1239	-0.1303	-0.1355	-0.1382
$x_2$	1	0.8333	0.6667	0.5778	0.52	0.485	0.4633	0.45	0.4418	0.4367	0.4336
$x_3$	0	0.5	0.0667	0.1	-0.0004	-0.0138	-0.0415	-0.0507	-0.0596	-0.0638	-0.0668
$\mathcal{E}$	Inf	Inf	1.24	1.0044	30	2.0095	0.2235	0.1741	0.0704	0.0484	

$\mathcal{E}$  for iteration 9 is less than 0.05.

$$\therefore x_1 = -0.14$$

$$x_2 = 0.43$$

$$x_3 = -0.07$$

**6.9**  $x_2 - 3x_1 + 1.9 = 0$

$$x_2 + x_1^2 - 3.0 = 0$$

Rearrange to solve for  $x_1$  and  $x_2$ :

$$x_1 = \frac{1}{3}x_2 + 0.6333$$

$$x_2 = 3.0 - x_1^2$$

Starting with an initial guess of  $x_1(0) = 1$  and  $x_2(0) = 1$

$$x_1(1) = \frac{1}{3}x_2(0) + 0.6333 = 0.9667$$

$$x_2(1) = 3 - [x_1(0)]^2 = 2$$

We repeat this procedure using the general equations

$$x_1(n+1) = \frac{1}{3}x_2(n) + 0.6333$$

$$x_2(n+1) = 3 - [x_1(n)]^2$$

$n$	0	1	2	3	...	47	48	49	50
$x_1$	1	0.9667	1.3	1.3219	...	1.1746	1.1735	1.1734	1.1743
$x_2$	1	2.0	2.0656	1.31	...	1.6205	1.6202	1.6229	1.6231

After 50 iterations,  $x_1$  and  $x_2$  have a precision of 3 significant digits.

$$x_1 = 1.17$$

$$x_2 = 1.62$$

**6.10**  $x^2 - 4x + 1 = 0$

Rearrange to solve for  $x$ :

$$x = \frac{1}{4}x^2 + \frac{1}{4}$$

Using the general form

$$x(n+1) = \frac{1}{4}[x(n)]^2 + \frac{1}{4} \quad \text{and} \quad x(0) = 1$$

we can obtain the following table:

$n$	0	1	2	3	4	5
$x$	1	0.5	0.3125	0.2744	0.2688	0.2681
$\varepsilon$	0.5	0.375	0.1219	0.0204	0.0028	

$$\varepsilon(4) = 0.0028 < 0.01$$

$$\therefore x = 0.27$$

Using the quadratic formula

$$x = \frac{-b \pm \sqrt{b^2 - 4ac}}{2a}$$

$$x = \frac{4 \pm \sqrt{(-4)^2 - 4}}{2}$$

$$x = 0.268, 3.732$$

Note: There does not exist an initial guess which will give us the second solution  $x = 3.732$ .

**6.11** After 100 iterations the Jacobi method does not converge.

After 100 iterations the Gauss-Seidel method does not converge.

**6.12** Rewriting the given equations,

$$x_1 = \frac{x_2}{3} + 0.633; \quad x_2 = 1.8 - x_1^2$$

With an initial guess of  $x_1(0) = 1$  and  $x_2(0) = 1$ ,

update  $x_1$  with the first equation above, and  $x_2$  with the second equation.

Thus 
$$x_1 = \frac{x_2(0)}{3} + 0.633 = \frac{1}{3} + 0.633 = 0.9663$$

and 
$$x_2 = 1.8 - x_1(0)^2 = 1.8 - 1 = 0.8$$

In succeeding iterations, compute more generally as

$$x_1(n+1) = \frac{x_2(n)}{3} + 0.633$$

and  $x_2(n+1) = 1.8 - x_1^2(n)$

After several iterations,  $x_1 = 0.938$  and  $x_2 = 0.917$ .

After a few more iterations,  $x_1 = 0.93926$  and  $x_2 = 0.9178$ .

However, note that an “uneducated guess” of initial values, such as  $x_1(0) = x_2(0) = 100$ , would have caused the solution to diverge.

**6.13**  $x_1 = \frac{1}{-20j} \left[ \frac{-1+0.5j}{x_1^*} - j10 \times x_2 - j10 \right]$

$$x_2 = \frac{1}{-20j} \left[ \frac{-3+j}{x_2^*} - j10 \times x_1 - j10 \right]$$

Rewriting in the general form:

$$x_1(n+1) = \frac{1}{-20j} \left[ \frac{-1+0.5j}{[x_1(n)]^*} - j10 \times x_2(n) - j10 \right]$$

$$x_2(n+1) = \frac{1}{-20j} \left[ \frac{-3+j}{[x_2(n)]^*} - j10 \times x_1(n+1) - j10 \right]$$

Solving using MATLAB with  $x_1(0) = 1, x_2(0) = 1, \epsilon = 0.05$ :

$$x_1 = 0.91 - 0.16j$$

$$x_2 = 0.86 - 0.22j$$

$$\epsilon = 0.036 \text{ after 3 iterations}$$

**6.14**  $f(x) = x^3 - 6x^2 + 9x - 4 = 0$

$$x = -\frac{1}{9}x^3 + \frac{2}{3}x^2 + \frac{4}{9} = g(x)$$

Apply Gauss-Seidel algorithm with  $x(0) = 2$ .

First iteration yields

$$x(1) = g(2) = -\frac{1}{9}2^3 + \frac{2}{3}2^2 + \frac{4}{9} = 2.2222$$

Second iteration:  $x(2) = g(2.2222) = 2.5173$

Subsequent iterations will result in

$$2.8966, 3.3376, 3.7398, 3.9568, 3.9988, \text{ and } 4.0000 \leftarrow$$

Note: There is a repeated root at  $x = 1$  also. With a wrong initial estimate, the solution might diverge.

**6.15**  $x^2 \cos x - x + 0.5 = 0$

Rearranging to solve for  $x$ ,

$$x = x^2 \cos x + 0.5$$

In the general form

$$x(n+1) = [x(n)]^2 \cos x(n) + 0.5$$

Solving using MATLAB with  $x(0) = 1$ ,  $\varepsilon = 0.01$ :

$$x = 1.05$$

$\varepsilon = 0.007$  after 2 iterations

To test which initial guesses result in convergence, we use MATLAB and try out initial guesses between  $-20$  and  $20$ , with a resolution of  $0.001$ . In the following plot the curve is the original function we solved. The shaded area is the values of  $x(0)$  which resulted in convergence.

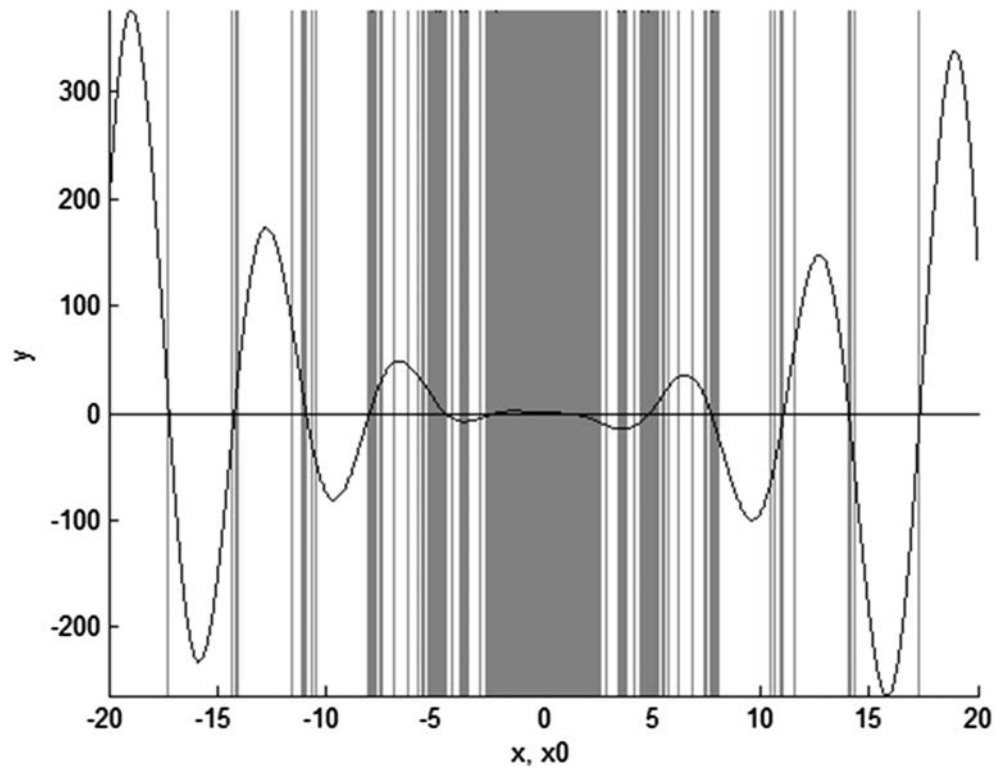

**6.16** Eq. (6.2.6) is:  $\underline{x}(i+1) = \underline{M}\underline{x}(i) = \underline{D}^{-1}\underline{y}$

Taking the Z transform (assume zero initial conditions):

$$\begin{aligned} z\underline{X}(z) &= \underline{M}\underline{X}(z) + \underline{D}^{-1}\underline{Y}(z) \\ (z\underline{U} - \underline{M})\underline{X}(z) &= \underline{D}^{-1}\underline{Y}(z) \\ \underline{X}(z) &= (z\underline{U} - \underline{M})^{-1} \underline{D}^{-1}\underline{Y}(z) = \underline{G}(z)\underline{Y}(z) \end{aligned}$$

**6.17** For Jacobi,

$$\begin{aligned} \underline{M} = \underline{D}^{-1}(\underline{D} - \underline{A}) &= \left[ \begin{array}{c|c} A_{11} & 0 \\ \hline 0 & A_{22} \end{array} \right]^{-1} \left[ \begin{array}{c|c} 0 & -A_{12} \\ \hline -A_{21} & 0 \end{array} \right] = \left[ \begin{array}{c|c} 0 & \frac{-A_{12}}{A_{11}} \\ \hline \frac{-A_{21}}{A_{22}} & 0 \end{array} \right] \\ \text{Det}(z\underline{U} - \underline{M}) = \text{Det} \left[ \begin{array}{c|c} z & \frac{A_{12}}{A_{11}} \\ \hline \frac{A_{21}}{A_{22}} & z \end{array} \right] &= z^2 - \frac{A_{12}A_{21}}{A_{11}A_{22}} = 0 \\ z &= \pm \sqrt{\left( \frac{A_{12}A_{21}}{A_{11}A_{22}} \right)} \end{aligned}$$

For Gauss-Seidel,

$$\begin{aligned} \underline{M} = \underline{D}^{-1}(\underline{D} - \underline{A}) &= \left[ \begin{array}{c|c} A_{11} & 0 \\ \hline A_{21} & A_{22} \end{array} \right]^{-1} \left[ \begin{array}{c|c} 0 & -A_{12} \\ \hline 0 & 0 \end{array} \right] = \left[ \begin{array}{c|c} 0 & \frac{-A_{12}}{A_{11}} \\ \hline 0 & \frac{A_{12}A_{21}}{A_{11}A_{22}} \end{array} \right] \\ \text{det}(z\underline{U} - \underline{M}) = \text{Det} \left[ \begin{array}{c|c} z & \frac{A_{12}}{A_{11}} \\ \hline 0 & z - \frac{A_{12}A_{21}}{A_{11}A_{22}} \end{array} \right] &= z \left( z - \frac{A_{12}A_{21}}{A_{11}A_{22}} \right) = 0 \\ z &= 0, \frac{A_{12}A_{21}}{A_{11}A_{22}} \end{aligned}$$

When  $N = 2$ , both Jacobi and Gauss-Seidel converge if and only if  $\left| \frac{A_{12}A_{21}}{A_{11}A_{22}} \right| < 1$ .

**6.18**  $x^3 + 8x^2 + 2x - 50 = 0$

$x(0) = 1$

$$J(i) = \left. \frac{df}{dx} \right|_{x=x(i)} = [3x^2 + 16x + 2]_{x=x(i)}$$

In the general form:

$$x(i+1) = x(i) + \frac{1}{3x(i)^2 + 16x(i) + 2} \times (-x(i)^3 - 8x(i)^2 - 2x(i) + 50)$$

Using  $x(0) = 1$ , we arrive at

<i>i</i>	0	1	2	3	4	5
<i>x</i>	1	2.857	2.243	2.129	2.126	2.126
$\epsilon$	1.857	0.215	0.051	0.0018	2.0E-6	

After 5 iterations,  $\epsilon < 0.001$ .

$\therefore x = 2.126$

**6.19** Repeating Problem 6.18 with  $x(0) = -2$ , we get:

<i>i</i>	0	1	2	3
<i>x</i>	-2	-3.67	-3.610	-3.611
$\epsilon$	0.833	0.015	0.00016	

After 3 iterations,  $\epsilon < 0.001$ . Therefore,

$x = -3.611$

Changing the initial guess from 1 to -2 caused the Newton-Raphson algorithm to converge to a different solution.

**6.20**  $x^4 + 3x^3 - 15x^2 - 19x + 30 = 7$

$$J(i) = \left. \frac{df}{dx} \right|_{x=x(i)} = [4x^3 + 9x^2 - 30x - 19]_{x=x(i)}$$

In general form

$$x(i+1) = x(i) + \frac{1}{4x(i)^3 + 9x(i)^2 - 30x(i) - 19} \times (7 - x(i)^4 - 3x(i)^3 + 15x(i)^2 + 19x(i) - 30)$$

Using  $x(0) = 0$ , we arrive at:

<i>i</i>	0	1	2	3	4
<i>x</i>	0	1.211	0.796	0.804	0.804
$\epsilon$	$\infty$	0.342	0.010	8.7E-6	

After 4 iterations,  $\epsilon < 0.001$ . Therefore,

$x = 0.804$

**6.21** Repeating Problem 6.20 with  $x(0) = 4$ , we arrive at  $x = 3.082$  after 4 iterations.

**6.22**

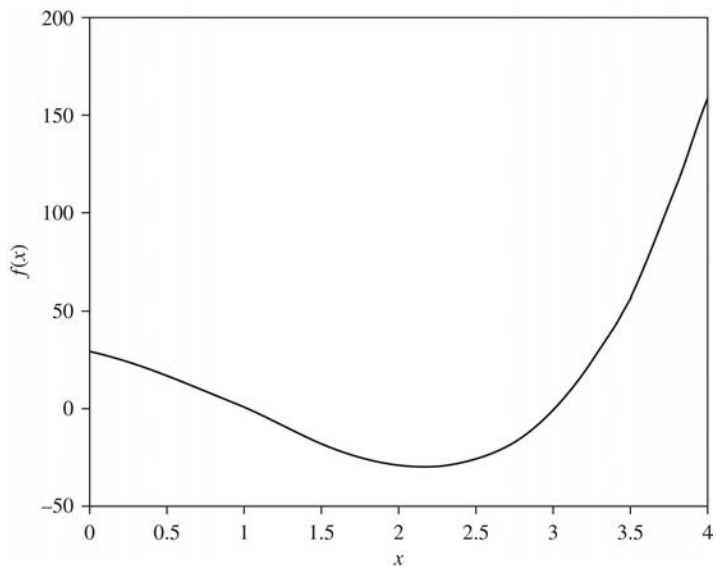

For points near  $x = 2.2$ , the function is flat, meaning the Jacobian is close to zero.

In Newton-Raphson, we iterate using the equation

$$x(i+1) = x(i) + J^{-1}(i)[y - f(x(i))]$$

If  $J(i)$  is close to zero,  $J^{-1}(i)$  will be a very large positive or negative number.

If we use an initial guess of  $x(0)$  which is near 2.2, the first iteration will cause  $x(i)$  to jump to a point far away from the solution, as illustrated in the following plot:

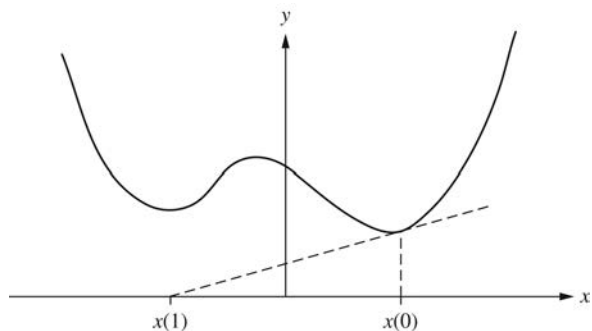

**6.23**  $J = \frac{df}{dx} = 4x^3 + 36x^2 + 108x + 108$

From Eq. (6.3.9):

$$x(i+1) = x(i) + \left[ 4x^3(i) + 36x^2(i) + 108x(i) + 108 \right] \left\{ 0 - \left[ x^4(i) + 12x^3(i) + 54x^2(i) + 108x(i) + 81 \right] \right\}$$

i	0	1	2	3	4	...	17	18	19
x(i)	-1	-1.5	-1.875	-2.15625	-2.3671875	...	-2.9848614	-2.989901	-2.9923223

$$\left| \frac{x(19) - x(18)}{x(18)} \right| = \left| \frac{-2.9923223 + 2.989901}{-2.989901} \right| = 0.0008$$

Stop after 19 iterations.  $x(19) = -2.9923223$ . Note that  $x = -3$  is one of four solutions to this 4<sup>th</sup> degree polynomial. The other three solutions are  $x = -3$ ,  $x = -3$ , and  $x = -3$ .

**6.24**  $2x_1^2 + x_2^2 - 10 = 0$

$$x_1^2 - x_2^2 + x_1x_2 - 4 = 0$$

$$J(i) = \frac{df}{dx} \Big|_{x=x(i)} = \begin{bmatrix} 4x_1 & 2x_2 \\ 2x_1 + x_2 & -2x_2 + x_1 \end{bmatrix}_{x=x(i)}$$

In general form

$$x(i+1) = x(i) - J^{-1}(i)f(x)$$

Solving using MATLAB with  $x_1(0) = 1, x_2(0) = 1, \epsilon = 0.001$ :

i	0	1	2	3	4
$x_1$	1	2.3	1.934	1.901	1.900
$x_2$	1	1.9	1.683	1.667	1.667
$\epsilon$	1.30	0.157	0.0175	2E-4	

After 4 iterations  $\epsilon < 0.001$ . Therefore,

$$x_1 = 1.900$$

$$x_2 = 1.667$$

**6.25**  $10x_1 \sin x_2 + 2 = 0$

$$10x_1^2 - 10x_1 \cos x_2 + 1 = 0$$

$$J(i) = \frac{df}{dx} \Big|_{x=x(i)} = \begin{bmatrix} 10 \sin x_2 & 10x_1 \sin x_2 \\ 20x_1 - 10 \cos x_2 & 10x_1 \sin x_2 \end{bmatrix}_{x=x(i)}$$

In the general form

$$x(i+1) = x(i) - J^{-1}(i)f(x)$$



Solving using MATLAB with  $x_1(0) = 1, x_2(0) = 0, \varepsilon = 1E-4$ :

i	0	1	2	3	4
$x_1$	1	0.90	0.8587	0.8554	0.8554
$x_2$	0	-0.20	-0.2333	-0.2360	-0.2360
$\varepsilon$	$\infty$	0.1667	0.01131	7.0E-5	

After 4 iterations, Newton-Raphson converges to

$$x_1 = 0.8554 \text{ rad}$$

$$x_2 = -0.2360 \text{ rad}$$

**6.26** Repeating Problem 6.25 with  $x_1(0) = 0.25$  and  $x_2(0) = 0$ , Newton-Raphson converges to

$$x_1 = 0.2614 \text{ rad}$$

$$x_2 = -0.8711 \text{ rad}$$

after 6 iterations.

**6.27** To determine which values of  $x_1(0)$  result in the answer obtained in Problem 6.25, we test out initial guesses for  $x_1$  between 0 and 1, with a resolution of 0.0001. The conclusion of this search is that if  $0.5 < x_1(0) \leq 1$  and  $x_2(0) = 0$ , Newton-Raphson will converge to  $x_1 = 0.8554$  rad and  $x_2 = -0.2360$  rad.

Note: If  $x_1(0) = 0.5$  and  $x_2(0) = 0$ . Newton-Raphson does not converge. This is because

$$J(0) = \begin{bmatrix} 4.79 & 5 \\ 0 & 0 \end{bmatrix}$$

Thus,  $J^{-1}$  does not exist.

**6.28** (a)  $Y_{11} = 2 - j4 + 3 - j6 = 5 - j10 = 11.18 \angle -63.43^\circ$

$$Y_{22} = 2 - j4 = 4.47 \angle -63.43^\circ$$

$$Y_{33} = 3 - j6 = 6.71 \angle -63.43^\circ$$

$$Y_{12} = Y_{21} = -2 + j4 = 4.47 \angle 116.57^\circ$$

$$Y_{13} = Y_{31} = -3 + j6 = 6.71 \angle 116.57^\circ$$

$$Y_{23} = Y_{32} = 0$$

$$(b) P_k = V_k \sum_{n=1}^N Y_{kn} V_n \cos(\delta_k - \delta_n - \theta_{kn})$$

At bus 2,

$$P_2 = V_2 \left[ Y_{21} V_1 \cos(\delta_2 - \delta_1 + \theta_{21}) + Y_{22} V_2 \cos(\delta_2 - \delta_2 - \theta_{22}) \right. \\ \left. + Y_{23} V_3 \cos(\delta_2 - \delta_3 - \theta_{23}) \right]$$

$$1.5 = 1.1 [4.47 \cos(\delta_2 - 116.57^\circ) + 4.47 \times 1.1 \cos(63.43^\circ)]$$

Solving for  $\delta_2$

$$\delta_2 = 15.795^\circ$$

(c) At bus3

$$P_3 = V_3 [Y_{31} V_1 \cos(\delta_3 - \delta_1 - \theta_{31}) + Y_{33} V_3 \cos(-\theta_{33})]$$

$$-1.5 = V_3 [6.71 \cos(\delta_3 - 116.57^\circ) + 6.71 V_3 \cos(63.43^\circ)] \quad \text{Eq. 1}$$

Also

$$Q_3 = V_3 [Y_{31} V_1 \sin(\delta_3 - \delta_1 - \theta_{31}) + Y_{33} V_3 \sin(-\theta_{33})]$$

$$0.8 = V_3 [6.71 \sin(\delta_3 - 116.57^\circ) + 6.71 V_3 \sin(63.43^\circ)] \quad \text{Eq. 2}$$

Solving for  $V_3$  and  $\delta_3$  using Eq. 1 and Eq. 2:

First, rearrange Eq. 1 and Eq. 2 to separate  $V_3$  and  $\delta_3$

$$-\frac{1.5}{6.71 V_3} - V_3 \cos(63.43^\circ) = \cos(\delta_3 - 116.57^\circ)$$

$$\frac{0.8}{6.71 V_3} - V_3 \sin(63.43^\circ) = \sin(\delta_3 - 116.57^\circ)$$

Next, square both sides of each equation, then add the two equations. The trigonometric identity  $\sin^2(\theta) + \cos^2(\theta) = 1$  can be used to simplify the right hand side.

$$\left[ \frac{1.5}{6.71 V_3} - V_3 \cos(63.43^\circ) \right]^2 + \left[ \frac{0.8}{6.71 V_3} - V_3 \sin(63.43^\circ) \right]^2 = 1$$

Solving, we get  $V_3 = 0.9723$  p.u.

Substitute  $V_3$  back into Eq. 1 or Eq. 2 to get  $\delta_3 = -15.10^\circ$ .

(d) At bus 1

$$P_1 = V_1 [Y_{11} V_1 \cos(-\theta_{11}) + Y_{12} V_2 \cos(-\delta_2 - \theta_{12}) + Y_{13} V_3 \cos(-\delta_3 - \theta_{13})]$$

$$= 11.18 \cos(63.43^\circ) + 4.47 \times 1.1 \cos(-15.795^\circ - 116.57^\circ)$$

$$+ 6.71 \times 0.9723 \cos(15.10^\circ - 116.57^\circ)$$

$$= 0.39 \text{ p.u.}$$

(e)

$$P_{\text{loss}} = P_{\text{gen}} - P_{\text{load}}$$

$$= P_1 + P_2 + P_3$$

$$= 0.39 + 1.5 - 1.5$$

$$= 0.39 \text{ p.u.}$$

**6.29**  $Y_{21} = 0$

$$Y_{22} = \frac{1}{0.009 + j0.100} + \frac{1}{0.009 + j0.100} + j\frac{1.72}{2} + j\frac{0.88}{2}$$

$$= 18.625 \angle -84.50^\circ$$

$Y_{23} = 0$

$$Y_{24} = -\frac{1}{0.009 + j0.100} = 9.960 \angle 95.14^\circ$$

$$Y_{25} = -\frac{1}{0.009 + j0.100} = 9.960 \angle 95.14^\circ$$

**6.30**

6.25 - j18.695	-5.00 + j15.00	-1.25 + j3.75	0	0
-5.00 + j15.00	12.9167 - j38.665	-1.6667 + j5.00	-1.25 + j3.75	-5.00 + j15.00
-1.25 + j3.75	-1.6667 + j5.00	8.7990 - j32.2294	-5.8824 + j23.5294	0
0	-1.25 + j3.75	-5.8824 + j23.5294	9.8846 - j36.4037	-2.7523 + j9.1743
0	-5.00 + j15.00	0	-2.7523 + j9.1743	7.7523 - j24.1443

**6.31** First, we need to find the per-unit shunt admittance of the added capacitor.

$$75 \text{ Mvar} = 0.75 \text{ p.u.}$$

To find  $Y$ , we use the relation

$$S = V^2 Y$$

$$Y = \frac{S}{V^2} = \frac{0.75}{1^2} = 0.75 \text{ p.u.}$$

Now, we can find  $Y_{44}$

$$Y_{44} = \frac{1}{0.08 + j0.24} + \frac{1}{0.01 + j0.04} + \frac{1}{0.03 + j0.10}$$

$$+ j\frac{0.05 + 0.01 + 0.04}{2} + j0.75$$

$$= 9.8846 - j35.6537$$

**6.32**

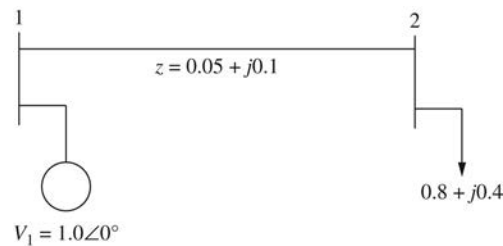

Assume flat start  $V_1(0) = 1.0 \angle 0$ ,  $V_2(0) = 1.0 \angle 0$

$$V_2(i+1) = \frac{1}{Y_{22}} \left[ \frac{P_2 - jQ_2}{V_2^*(i)} - Y_{21}V_1(i) \right]$$

$$Y_{21} = -\frac{1}{0.05 + j0.1} = -4 + j8$$

$$Y_{22} = \frac{1}{0.05 + j0.1} = 4 - j8$$

Using MATLAB, with  $V_1(0) = 1.0 \angle 0$  and  $V_2(0) = 1.0 \angle 0$ :

$i$	0	1	2	3
$V_2$	$1.0 \angle 0$	$0.9220 \angle -3.7314^\circ$	$0.9111 \angle -3.7314$	$0.9101 \angle -3.7802^\circ$

After 3 iterations,

$$V_2 = 0.9101 \angle -3.7802^\circ$$

**6.33** If we repeat Problem 6.32 with  $V_2(0) = 1.0 \angle 30^\circ$ , we get  $V_2 = 0.9107 \angle -3.8037^\circ$  after 3 iterations.

**6.34**  $V_1 = 1.0 \angle 0$

$$V_2(i+1) = \frac{1}{Y_{22}} \left[ \frac{P_2 - jQ_2}{V_2^*(i)} - Y_{21}V_1 - Y_{23}V_3(i) \right]$$

$$= \frac{1}{-j10} \left[ \frac{1 - j0.5}{V_2^*(i)} - j5V_1 - j5V_3(i) \right]$$

$$V_3(i+1) = \frac{1}{Y_{33}} \left[ \frac{P_3 - jQ_3}{V_3^*(i)} - Y_{31}V_1 - Y_{32}V_2(i+1) \right]$$

$$= \frac{1}{-j10} \left[ \frac{1.5 - j0.75}{V_3^*(i)} - j5V_1 - j5V_2(i+1) \right]$$

Solving using MATLAB with  $V_2(0) = 1.0 \angle 0$  and  $V_3(0) = 1.0 \angle 0$ :

$i$	0	1	2
$V_2$	$1.0 \angle 0$	$0.9552 \angle -6.0090^\circ$	$0.9090 \angle -12.6225^\circ$
$V_3$	$1.0 \angle 0$	$0.9220 \angle -12.5288^\circ$	$0.8630 \angle -16.1813^\circ$

After 2 iterations,

$$V_2 = 0.9090 \angle -12.6225^\circ$$

$$V_3 = 0.8630 \angle -16.1813^\circ$$

**6.35** Repeating Problem 6.34 with  $V_1 = 1.05 \angle 0$

$i$	0	1	2
$V_2$	$1.0 \angle 0$	$0.9801 \angle -5.8560^\circ$	$0.9530 \angle -11.8861^\circ$
$V_3$	$1.0 \angle 0$	$0.9586 \angle -12.0426^\circ$	$0.9129 \angle -14.9085^\circ$

After 2 iterations,

$$V_2 = 0.9530 \angle -11.8861^\circ$$

$$V_3 = 0.9129 \angle -14.9085^\circ$$

$$\begin{aligned} \mathbf{6.36} \quad V_2^1 &= \frac{1}{Y_{22}} \left[ \frac{P_2 - jQ_2}{(V_2^0)^*} - Y_{21}V_1 - Y_{23}V_3^0 - Y_{24}V_4^0 \right] \\ &= \frac{1}{Y_{22}} \left[ \frac{0.5 + j0.2}{1 - j0} - 1.04(-2 + j6) - (-0.666 + j2) - (-1 + j3) \right] \\ &= \frac{4.246 - j11.04}{3.666 - j11} = 1.019 + j0.046 = 1.02 \angle 2.58^\circ \text{ p.u.} \end{aligned}$$

$$V_2^2 = \frac{1}{Y_{22}} \left[ \frac{P_2 - jQ_2}{(V_2^1)^*} - Y_{21}V_1 - Y_{23}V_3^1 - Y_{24}V_4^1 \right]$$

Determine  $V_3^1$  and  $V_4^1$  in the same way as  $V_2^1$ . Then

$$\begin{aligned} V_2^2 &= \frac{1}{Y_{22}} \left[ \frac{0.5 + j0.2}{1.019 + j0.046} - 1.04(-2 + j6) - (-0.666 + j2.0)(1.028 - j0.087) \right. \\ &\quad \left. - (-1 + j3)(1.025 - j0.0093) \right] \\ &= \frac{4.0862 - j11.6119}{3.666 - j11.0} = 1.061 + j0.0179 = 1.0616 \angle 0.97^\circ \text{ p.u.} \end{aligned}$$

**6.37** Gauss-Seidel iterative scheme:

With  $\delta_2 = 0; V_3 = 1 \text{ p.u.}; \delta_3 = 0$  (starting values)

$$\text{Given} \quad \bar{Y}_{Bus} = -j \begin{bmatrix} 7 & -2 & -5 \\ -2 & 6 & -4 \\ -5 & -4 & 9 \end{bmatrix};$$

$$\text{Also given} \quad \bar{V}_1 = 1.0 \angle 0^\circ \text{ p.u.}$$

$$\bar{V}_2 = 1.0 \text{ p.u.}; P_2 = 60 \text{ MW}$$

$$P_3 = -80 \text{ MW}; Q_3 = -60 \text{ M var (lag)}$$

Iteration 1:

$$Q_2 = -\text{Im}(\bar{Y}_{22}\bar{V}_2 + \bar{Y}_{21}\bar{V}_1 + \bar{Y}_{23}\bar{V}_3)\bar{V}_2^*$$

$$= -\text{Im}\{[-j6(1\angle 0) + j2(1\angle 0) + j4(1\angle 0)]1\angle 0\} = 0$$

$$\bar{V}_2 = \frac{1}{\bar{Y}_{22}} \left( \frac{P_2 - jQ_2}{\bar{V}_2^*} - \bar{Y}_{21}\bar{V}_1 - \bar{Y}_{23}\bar{V}_3 \right)$$

$$= \frac{1}{-j6} \left[ \frac{0.6 + j0}{1\angle 0} - j2(1\angle 0) - j4(1\angle 0) \right]$$

$$= 1 + j0.1 \approx 1\angle 5.71^\circ$$

Repeat:  $\bar{V}_2 = 1 + \frac{0.1\angle 90^\circ}{1\angle -5.71^\circ} = 0.99005 + j0.0995$

$$= 0.995\angle 5.74^\circ$$

$$\bar{V}_2 = 1\angle 5.74^\circ = 0.995 + j0.1$$

$$\bar{V}_3 = \frac{1}{\bar{Y}_{33}} \left[ \frac{P_3 - jQ_3}{\bar{V}_3^*} - \bar{Y}_{31}\bar{V}_1 - \bar{Y}_{32}\bar{V}_2 \right]$$

$$= \frac{1}{-j9} \left[ \frac{-0.8 + j0.6}{1\angle 0} - j5(1\angle 0) - j4(0.995 + j0.1) \right]$$

$$= 0.9978 + j0.0444 - \frac{0.1111\angle 53.13^\circ}{1\angle 0}$$

$$= 0.9311 - j0.0444 = 0.9322\angle -2.74^\circ$$

Repeat:  $\bar{V}_3 = 0.9978 + j0.0444 - \frac{0.1111\angle 53.13^\circ}{0.9322\angle 2.74^\circ}$

$$= 0.9218 - j0.0474 = 0.923\angle -2.94^\circ$$

Check:  $\Delta\bar{V}_2 = (0.995 + j0.100) - (1 - j0) = -0.005 + j0.1$

$$\Delta\bar{V}_3 = (0.9218 + j0.0474) - (1 - j0) = -0.0782 - j0.0474$$

$$\Delta x_{\max} = 0.1$$

Iteration 2:

$$Q_2 = -\text{Im}\{[-j6(0.995 + j0.1) + j2(1\angle 0) + j4(0.9218 - j0.0474)](0.995 - j0.1)\}$$

$$= 0.36$$

$$\bar{V}_2 = \frac{1}{-j6} \left[ \frac{0.6 - j0.36}{1\angle -5.74^\circ} - j2(1\angle 0) - j4(0.9218 - j0.0474) \right]$$

$$= 0.9479 + j0.316 + \frac{0.1166\angle 59.04^\circ}{1\angle -5.74^\circ} = 1\angle 4.24^\circ = 0.9973 + j0.0739$$

$$\begin{aligned} \text{Repeat: } \bar{V}_2 &= 0.9479 - j0.0316 + \frac{0.1166 \angle 59.04}{1 \angle -4.24} = 1.0003 + j0.0725 \\ &\approx 1 \angle 4.15 = 0.9974 + j0.0723 \\ \bar{V}_3 &= \frac{1}{j9} \left[ \frac{-0.8 + j0.6}{0.9230 \angle 2.94} - j5(1 \angle 0) - j4(0.9974 + j0.0723) \right] \\ &= 0.9988 + j0.0321 - \frac{0.1111 \angle 53.13^\circ}{0.923 \angle 2.94} = 0.9217 - j0.0604 \\ &= 0.9237 \angle -3.75 \end{aligned}$$

$$\begin{aligned} \text{Repeat: } \bar{V}_3 &= 0.9988 + j0.0321 - \frac{0.1111 \angle 53.13^\circ}{0.9237 \angle 3.75^\circ} = 0.9205 - j0.0592 \\ &= 0.9224 \angle -3.68 \end{aligned}$$

$$\begin{aligned} \text{Check: } \Delta \bar{V}_2 &= (0.9974 + j0.0732) - (0.995 + j0.1) = 0.0024 - j0.0277 \\ \Delta \bar{V}_3 &= (0.9205 - j0.0592) - (0.9218 - j0.0474) = -0.0013 - j0.0118 \\ \Delta x_{\max} &= 0.028 \end{aligned}$$

Third iteration yields the following results within the desired tolerance:

$$\left. \begin{aligned} \bar{V}_2 &= 0.9981 + j0.0610 = 1 \angle 3.5^\circ \\ \bar{V}_3 &= 0.9208 - j0.0644 = 0.923 \angle -4^\circ \end{aligned} \right\} \leftarrow$$

### 6.38

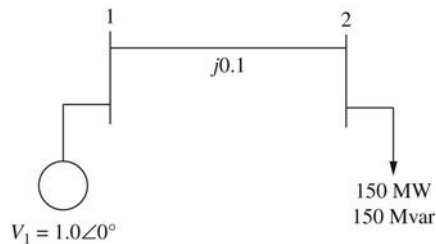

First, convert all values to per-unit.

$$P_{\text{pu}} = \frac{P}{S_{\text{base}}} = \frac{-150 \text{ MW}}{100 \text{ MVA}} = -1.5 \text{ p.u.}$$

$$Q_{\text{pu}} = \frac{Q}{S_{\text{base}}} = \frac{-50 \text{ MW}}{100 \text{ MVA}} = -0.5 \text{ p.u.}$$

$$\Delta y_{\text{max,pu}} = \frac{\Delta y_{\text{max}}}{S_{\text{base}}} = \frac{0.1 \text{ MVA}}{100 \text{ MVA}} = 1\text{E-}4 \text{ p.u.}$$

Since there are 2 buses, we need to solve  $2(n-1) = 2$  equations.

Therefore, J has dimension  $2 \times 2$ .

Using Table 6.5

$$J1_{22} = -V_2 V_{21} V_1 \sin(\delta_2 - \delta_1 - \theta_{21})$$

$$J2_{22} = V_2 Y_{22} \cos(\theta_{22}) + Y_{21} V_1 \cos(\delta_2 - \delta_1 - \theta_{21}) + Y_{22} V_2 \cos(-\theta_{22})$$

$$J3_{22} = V_2 Y_{21} V_1 \cos(\delta_2 - \delta_1 - \theta_{21})$$

$$J4_{22} = -V_2 Y_{22} \sin \theta_{22} + Y_{21} V_1 \sin(\delta_2 - \delta_1 - \theta_{21}) + Y_{22} + V_2 \sin(-\theta_{22})$$

Also,

$$Y_{\text{bus}} = \begin{bmatrix} -j10 & j10 \\ j10 & -j10 \end{bmatrix} = \begin{bmatrix} 10 \angle -90 & 10 \angle 90 \\ 10 \angle 90 & 10 \angle -90 \end{bmatrix}$$

Finally, using Eqs. (6.6.2) and (6.6.3),

$$P_2(\delta_2, V_2) = V_2 [Y_{21} V_1 \cos(\delta_2 - \delta_1 - \theta_{21}) + Y_{22} V_2 \cos(-\theta_{22})]$$

$$Q_2(\delta_2, V_2) = V_2 [Y_{21} V_1 \sin(\delta_2 - \delta_1 - \theta_{21}) + Y_{22} V_2 \sin(-\theta_{22})]$$

Solving using MATLAB with  $V_2(0) = 1.0 \angle 0$ ,

$i$	0	1	2	3
$V_2$	$1.0 \angle 0$	$0.9500 \angle -8.5944^\circ$	$0.9338 \angle -9.2319^\circ$	$0.9334 \angle -9.2473^\circ$

After 3 iterations

$$V_2 = 0.9334 \angle -9.2473^\circ$$

**6.39** If we repeat Problem 6.38 with  $V_2(0) = 1.0 \angle 30^\circ$ , Newton-Raphson converges to  $0.9334 \angle -9.2473^\circ$  after 5 iterations.

**6.40** If we repeat Problem 6.38 with  $V_2(0) = 0.25 \angle 0^\circ$ , Newton-Raphson converges to  $V_2 = 0.1694 \angle -27422.32^\circ = 0.1694 \angle -62.32^\circ$  after 14 iterations.

**6.41** The number of equations is  $2(n-1) = 4$ . Therefore,  $J$  will have dimension  $4 \times 4$ .  
Using Table 6.5

$$J(0) = \begin{bmatrix} 10 & -5 & 0 & 0 \\ -5 & 10 & 0 & 0 \\ 0 & 0 & 10 & -5 \\ 0 & 0 & -5 & 10 \end{bmatrix}$$

**6.42** First, we convert the mismatch into per-unit  $0.1 \text{ MVA} = 1\text{E-}4 \text{ p.u.}$  with  $S_{\text{base}} = 100 \text{ MVA}$ .  
Solving using MATLAB with  $V_2(0) = 1.0 \angle 0$  and  $V_3(0) = 1.0 \angle 0$ ,

$i$	0	1	2	3	4
$V_2$	$1.0 \angle 0$	$0.8833 \angle -13.3690^\circ$	$0.8145 \angle -16.4110^\circ$	$0.8019 \angle -16.9610^\circ$	$0.8015 \angle -16.9811^\circ$
$V_3$	$1.0 \angle 0$	$0.8667 \angle -15.2789^\circ$	$0.7882 \angle -19.2756^\circ$	$0.7731 \angle -20.1021^\circ$	$0.7725 \angle -20.1361^\circ$



After 4 iterations, Newton-Raphson converges to

$$V_2 = 0.8015 \angle -16.9811^\circ$$

$$V_3 = 0.7725 \angle -20.1361^\circ$$

**6.43** (a) *Step 1*

By inspection:

$$\bar{Y}_{\text{Bus}} = \begin{bmatrix} -j12.5 & +j10.0 & +j2.5 \\ +j10.0 & -j15.0 & +j5.0 \\ +j2.5 & +j5.0 & -j7.5 \end{bmatrix}$$

$$\delta_2(0) = \delta_3(0) = 0^\circ \quad V_2(0) = 1.0$$

Compute  $\Delta y(0)$

$$P_2(X) = 1.0[10 \cos(-90^\circ) + 5 \cos(-90^\circ)] = 0$$

$$P_3(X) = 2.5 \cos(-90^\circ) + 5 \cos(-90^\circ) = 0$$

$$Q_2(X) = 1.0[10 \sin(-90^\circ) + 15 + 5 \sin(-90^\circ)] = 0$$

$$\Delta y(0) = \begin{bmatrix} P_2 - P_2(X) \\ P_3 - P_3(X) \\ Q_2 - Q_2(X) \end{bmatrix} = \begin{bmatrix} -2.0 - 0 \\ 1.0 - 0 \\ -0.5 - 0 \end{bmatrix} = \begin{bmatrix} -2.0 \\ 1.0 \\ -0.5 \end{bmatrix}$$

(b) *Step 2*      Compute  $J(0)$  (see Table 6.5 text)

$$\begin{aligned} J_{122} &= \frac{\partial P_2}{\partial \delta_2} = -V_2 [Y_{21} V_1 \sin(\delta_2 - \delta_1 - \theta_{21}) + Y_{23} V_3 \sin(\delta_2 - \delta_3 - \theta_{23})] \\ &= -1.0[10(1) \sin(-90^\circ) + 5(1) \sin(-90^\circ)] = 15. \end{aligned}$$

$$J_{123} = \frac{\partial P_2}{\partial \delta_3} = V_2 Y_{23} V_3 \sin(\delta_2 - \delta_3 - \theta_{23}) = (1.0)(5) \sin(-90^\circ) = -5.$$

$$J_{132} = \frac{\partial P_3}{\partial \delta_2} = V_3 Y_{32} V_2 \sin(\delta_3 - \delta_2 - \theta_{32}) = (1)(5)(1) \sin(-90^\circ) = -5$$

$$\begin{aligned} J_{133} &= \frac{\partial P_3}{\partial \delta_3} = -V_3 [Y_{31} V_1 \sin(\delta_3 - \delta_1 - \theta_{31}) + Y_{32} V_2 \sin(\delta_3 - \delta_2 - \theta_{32})] \\ &= -1.0[(2.5)(1) \sin(-90^\circ) + (5)(1) \sin(-90^\circ)] = 7.5 \end{aligned}$$

$$\begin{aligned} J_{222} &= \frac{\partial P_2}{\partial V_2} = V_2 Y_{22} \cos(\theta_{22}) + [Y_{21} V_1 \cos(\delta_2 - \delta_1 - \theta_{21}) + Y_{22} V_2 \cos(-\theta_{22}) \\ &\quad + Y_{23} V_3 \cos(\delta_2 - \delta_3 - \theta_{23})] = 0 \end{aligned}$$

$$J2_{32} = \frac{\partial P_3}{\partial V_2} = V_3 Y_{32} \cos(\delta_3 - \delta_2 - \theta_{32}) = 0$$

$$J3_{22} = \frac{\partial Q_2}{\partial \delta_2} = V_2 [Y_{21} V_1 \cos(\delta_2 - \delta_1 - \theta_{21})] + Y_{23} V_3 \cos(\delta_2 - \delta_3 - \theta_{23}) = 0$$

$$J3_{23} = \frac{\partial Q_2}{\partial \delta_3} = -V_2 Y_{23} V_3 \cos(\delta_2 - \delta_3 - \theta_{23}) = 0$$

$$J4_{22} = \frac{\partial Q_2}{\partial V_2} = -V_2 Y_{22} \sin \theta_{22} + \left[ \begin{array}{l} Y_{21} V_1 \sin(\delta_2 - \delta_1 - \theta_{21}) + Y_{22} V_2 \sin(-\theta_{22}) \\ + Y_{23} V_3 \sin(\delta_2 - \delta_3 - \theta_{23}) \end{array} \right]$$

$$J4_{22} = (-1)(15) \sin(-90^\circ) + [(10)(1) \sin(-90^\circ) + 15(1) \sin(90^\circ) + 5(1) \sin(-90^\circ)] \\ = 15$$

$$\underline{J}(0) = \left[ \begin{array}{cc|c} \underline{J1} & \underline{J2} & \\ \underline{J3} & \underline{J4} & \\ \hline 0 & 0 & 15 \end{array} \right] = \left[ \begin{array}{cc|c} 15 & -5 & 0 \\ -5 & 7.5 & 0 \\ \hline 0 & 0 & 15 \end{array} \right] \text{ per unit}$$

Step 3 Solve  $J \Delta x = \Delta y$

$$\left[ \begin{array}{ccc} 15 & -5 & 0 \\ -5 & 7.5 & 0 \\ 0 & 0 & 15 \end{array} \right] \left[ \begin{array}{c} \Delta \delta_2 \\ \Delta \delta_3 \\ \Delta V_2 \end{array} \right] = \left[ \begin{array}{c} -2.0 \\ 1.0 \\ -0.5 \end{array} \right]$$

Using Gauss elimination, multiply the first equation by  $(-5/15)$  and subtract from the second equation:

$$\left[ \begin{array}{ccc} 15 & -5 & 0 \\ 0 & 5.833333 & 0 \\ 0 & 0 & 15 \end{array} \right] \left[ \begin{array}{c} \Delta \delta_2 \\ \Delta \delta_3 \\ \Delta V_2 \end{array} \right] = \left[ \begin{array}{c} -2.0 \\ 0.333333 \\ -0.5 \end{array} \right]$$

Back substitution:

$$\Delta V_2 = -0.5/15 = -0.0333333$$

$$\Delta \delta_3 = 0.333333/5.833333 = 0.05714285$$

$$\Delta \delta_2 = [-2.0 + 5(0.05714285)]/15 = -0.1142857$$

$$\Delta x = \left[ \begin{array}{c} \Delta \delta_2 \\ \Delta \delta_3 \\ \Delta V_2 \end{array} \right] = \left[ \begin{array}{c} -0.1142857 \\ 0.05714285 \\ -0.0333333 \end{array} \right]$$

Step 4 Compute  $x(1)$

$$\underline{x}(1) = \left[ \begin{array}{c} \delta_2(1) \\ \delta_3(1) \\ V_2(1) \end{array} \right] = x(0) + \Delta x = \left[ \begin{array}{c} 0 \\ 0 \\ 1 \end{array} \right] + \left[ \begin{array}{c} -0.1142857 \\ 0.05714285 \\ -0.0333333 \end{array} \right] = \left[ \begin{array}{c} -0.1142857 \\ 0.05714285 \\ 0.96666667 \end{array} \right] \begin{array}{l} \text{radians} \\ \text{radians} \\ \text{per unit} \end{array}$$

Check  $Q_{G3}$  using Eq. (6.5.3)

$$\begin{aligned}
Q_3 &= V_3 [Y_{31} V_1 \sin(\delta_3 - \delta_1 - \theta_{31}) + Y_{32} V_2 \sin(\delta_3 - \delta_2 - \theta_{32}) + Y_{33} V_3 \sin(-\theta_{33})] \\
&= 1 \left[ (2.5)(1) \sin \left( \underbrace{0.05714}_{\text{radians}} - \frac{\pi}{2} \right) + 5(0.966666) \sin \left( 0.05714 + 0.11429 - \frac{\pi}{2} \right) \right. \\
&\qquad \qquad \qquad \left. + 7.5(1) \sin \left( \frac{\pi}{2} \right) \right]
\end{aligned}$$

$$Q_3 = 1[-2.4959 - 4.7625 + 7.5] = 0.2416 \text{ per unit}$$

$$Q_{G3} = Q_3 + Q_{L3} = 0.2416 + 0 = 0.2416 \text{ per unit}$$

Since  $Q_{G3} = 0.2416$  is within the limits  $[-5.0, +5.0]$ , bus 3 remains a voltage-controlled bus. This completes the first Newton-Raphson iteration.

**6.44** Repeating Problem 6.43 with  $P_{G2} = 1.0$  p.u.

(a) *Step 1*

$Y_{\text{bus}}$  stays the same.

$P_2(x(0)), P_3(x(0)), Q_2(x(0))$  also stay the same.

$$\Delta y(0) = \begin{bmatrix} P_2 - P_2(x(0)) \\ P_3 - P_3(x(0)) \\ Q_2 - Q_2(x(0)) \end{bmatrix} = \begin{bmatrix} -2.0 + 1.0 - 0 \\ 1.0 - 0 \\ -0.5 - 0 \end{bmatrix} = \begin{bmatrix} -1.0 \\ 1.0 \\ -0.5 \end{bmatrix}$$

(b) *Step 2*

The Jacobian stays the same.

$$J(0) = \begin{bmatrix} 15 & -5 & 0 \\ -5 & 7.5 & 0 \\ 0 & 0 & 15 \end{bmatrix}$$

(c) *Step 3*

Solve  $J\Delta x = \Delta y$

$$\begin{bmatrix} 15 & -5 & 0 \\ -5 & 7.5 & 0 \\ 0 & 0 & 15 \end{bmatrix} \begin{bmatrix} \Delta \delta_2 \\ \Delta \delta_3 \\ \Delta V_2 \end{bmatrix} = \begin{bmatrix} -1.0 \\ 1.0 \\ -0.5 \end{bmatrix}$$

Multiply the first equation by  $\frac{-5}{15}$  and subtract from the second equation.

$$\begin{bmatrix} 15 & -5 & 0 \\ 0 & 35/6 & 0 \\ 0 & 0 & 15 \end{bmatrix} \begin{bmatrix} \Delta \delta_2 \\ \Delta \delta_3 \\ \Delta V_2 \end{bmatrix} = \begin{bmatrix} -1.0 \\ 2/3 \\ -0.5 \end{bmatrix}$$

Via back substitution

$$\Delta V_2 = \frac{-0.5}{15} = -0.033333$$

$$\Delta \delta_3 = \frac{2/3}{35/6} = 0.11429$$

$$\Delta \delta_2 = (-1.0 + 5 \times 0.11429) / 15 = -0.028571$$

(d) *Step 4*

$$x(1) = x(0) + \Delta x = \begin{bmatrix} 0 \\ 0 \\ 1 \end{bmatrix} + \begin{bmatrix} -0.028571 \\ 0.11429 \\ -0.033333 \end{bmatrix} = \begin{bmatrix} -0.028571 \\ 0.11429 \\ 0.96667 \end{bmatrix}$$

Check  $Q_{G3}$  using Eq. (6.5.3)

$$\begin{aligned} Q_3 &= V_3 \left[ Y_{31} V_1 \sin(\delta_3 - \delta_1 - \theta_{31}) + Y_{32} V_2 \sin(\delta_3 - \delta_2 - \theta_{32}) + Y_{33} V_3 \sin(-\theta_{33}) \right] \\ &= 1.0 \left[ 2.5 \times 1.0 \sin\left(0.11429 - \frac{\pi}{2}\right) + 5 \times 0.96667 \sin\left(0.11429 + 0.028571 - \frac{\pi}{2}\right) \right. \\ &\quad \left. + 7.5 \times 1.0 \sin\left(\frac{\pi}{2}\right) \right] \\ &= 0.2322 \text{ p.u.} \end{aligned}$$

$$Q_{G3} = Q_3 + Q_{L3} = 0.2322 + 0 = 0.2322 \text{ p.u.}$$

Since  $Q_{G3}$  is within the limits  $[-5.0, 5.0]$ , bus 3 remains a voltage controlled bus.

$\therefore$  After the first iteration,

$$x = \begin{bmatrix} \delta_2 \\ \delta_3 \\ V_2 \end{bmatrix} = \begin{bmatrix} -0.028571 \\ 0.11429 \\ 0.96667 \end{bmatrix}$$

**6.45** After the first three iterations  $J_{22} = 104.41, 108.07, 107.24$ ; and with the next iteration it converges to 106.66.

**6.46** First, convert all values to per-unit.

$$P_{G2} = 80 \text{ MW} = 0.8 \text{ p.u.}$$

$$P_{L3} = 180 \text{ MW} = 1.8 \text{ p.u.}$$

For convergence,  $\Delta y_{\max} = 0.1 \text{ MVA} = 1\text{E-}4 \text{ p.u.}$

Second, find  $Y_{\text{bus}}$ .

$$Y_{\text{bus}} = \begin{bmatrix} 8 - j16 & -4 + j8 & -4 + j8 \\ -4 + j8 & 8 - j16 & -4 + j8 \\ -4 + j8 & -4 + j8 & 8 - j16 \end{bmatrix}$$

To solve the case, we follow the steps outlined in section 6.6.

*Iteration 0*

*Step 1*

$$\text{Start with } x(0) = \begin{bmatrix} \delta_2(0) \\ \delta_3(0) \\ V_3(0) \end{bmatrix} = \begin{bmatrix} 0 \\ 0 \\ 1 \end{bmatrix}$$

$$P(x(0)) = \begin{bmatrix} P_2(x(0)) \\ P_3(x(0)) \end{bmatrix} = \begin{bmatrix} 0 \\ 0 \end{bmatrix}$$

$$Q(x(0)) = Q_3(x(0)) = 0$$

$$\Delta y(0) = \begin{bmatrix} P_2 - P_2(x(0)) \\ P_3 - P_3(x(0)) \\ Q_3 - Q_3(x(0)) \end{bmatrix} = \begin{bmatrix} 0.8 \\ -1.8 \\ 0 \end{bmatrix}$$

*Step 2*

$$J1 = \begin{bmatrix} 16 & -8 \\ -8 & 16 \end{bmatrix} \quad J2 = \begin{bmatrix} -4 \\ 8 \end{bmatrix}$$

$$J3 = [4 \quad -8] \quad J4 = [16]$$

$$J(0) = \left[ \begin{array}{cc|c} 16 & -8 & -4 \\ -8 & 16 & 8 \\ \hline 4 & -8 & 16 \end{array} \right]$$

*Step 3*

$$J(0)\Delta x(0) = \Delta y(0)$$

$$\begin{bmatrix} 16 & -8 & -4 \\ -8 & 16 & 8 \\ 4 & -8 & 16 \end{bmatrix} \begin{bmatrix} \Delta \delta_2(0) \\ \Delta \delta_3(0) \\ \Delta V_3(0) \end{bmatrix} = \begin{bmatrix} 0.8 \\ -1.8 \\ 0 \end{bmatrix}$$

$$\Delta x(0) = \begin{bmatrix} -0.0083333 \\ -0.094167 \\ -0.045 \end{bmatrix}$$

*Step 4*

$$x(1) = x(0) + \Delta x(0) = \begin{bmatrix} -0.0083333 \\ -0.094167 \\ 0.955 \end{bmatrix}$$

*Iteration 1*

*Step 1*

$$P(x(1)) = \begin{bmatrix} 0.7825 \\ -1.6861 \end{bmatrix}$$

$$Q(x(1)) = 0.0610$$

$$\Delta y(1) = \begin{bmatrix} 0.017502 \\ -0.11385 \\ -0.06104 \end{bmatrix}$$

*Step 2*

$$J(1) = \begin{bmatrix} 15.9057 & -7.93935 & -3.29945 \\ -7.28439 & 14.5314 & 5.8744 \\ 4.4609 & -8.98235 & 15.3439 \end{bmatrix}$$

*Step 3*

$$\Delta x(1) = \begin{bmatrix} -0.0038007 \\ -0.0069372 \\ -0.0069342 \end{bmatrix}$$

*Step 4*

$$x(2) = \begin{bmatrix} -0.012134 \\ -0.1011 \\ 0.94807 \end{bmatrix}$$

*Iteration 2*

*Step 1*

$$P(x(2)) = \begin{bmatrix} 0.7999 \\ -1.7990 \end{bmatrix}$$

$$Q(x(2)) = 6.484 \text{ E-4}$$

$$\Delta y(2) = \begin{bmatrix} 1.3602 \text{ E-4} \\ -1.0458 \text{ E-4} \\ -6.484 \text{ E-4} \end{bmatrix}$$

*Step 2*

$$J(2) = \begin{bmatrix} 15.8424 & -7.89148 & -3.27336 \\ -7.21758 & 14.3806 & 5.68703 \\ 4.45117 & -8.98958 & 15.1697 \end{bmatrix}$$

*Step 3*

$$\Delta x(2) = \begin{bmatrix} -3.7748 \text{ E-5} \\ -6.412 \text{ E-5} \\ -6.9664 \text{ E-5} \end{bmatrix}$$

Step 4

$$x(3) = \begin{bmatrix} -0.012172 \\ -0.10117 \\ 0.948 \end{bmatrix}$$

Iteration 3

Step 1

$$P(x(3)) = \begin{bmatrix} 0.8000 \\ -1.8000 \end{bmatrix}$$

$$Q(x(3)) = 6.4875 \text{ E-8}$$

$$\Delta y(3) = \begin{bmatrix} 1.1294 \text{ E-8} \\ -9.7437 \text{ E-8} \\ -6.4875 \text{ E-8} \end{bmatrix}$$

$$\Delta y(3) < 1\text{E-4}$$

∴ Newton-Raphson has converged in 3 iterations to

$$V_1 = 1.0 \angle 0$$

$$V_2 = 1.0 \angle -0.012172 \text{ rad} = 1.0 \angle -0.6974^\circ$$

$$V_3 = 0.948 \angle -0.10117 \text{ rad} = 0.948 \angle -5.797^\circ$$

Using the voltages, we can calculate the powers at buses 1 and 2 with Eqs. (6.6.2) and (6.6.3).

$$P_1 = 1.0910 \text{ p.u.} = 109.10 \text{ MW}$$

$$Q_1 = 0.0237 \text{ p.u.} = 2.37 \text{ Mvar}$$

$$Q_2 = 0.1583 \text{ p.u.} = 15.83 \text{ Mvar}$$

Using PowerWorld simulator, we get

$$P_1 = 109.1 \text{ MW}$$

$$Q_1 = 2.4 \text{ Mvar}$$

$$Q_2 = 15.8 \text{ Mvar}$$

$$V_3 = 0.948 \text{ p.u.}$$

which agrees with our solution.

**6.47** First, convert values to per-unit

$$Q_2 = 50 \text{ Mvar} = 0.5 \text{ p.u.}$$

$Y_{\text{bus}}$  stays the same as in Problem 6.46.

Since bus 2 is now a  $PQ$  bus, we introduce a fourth equation in order to solve for  $V_2$ .

*Iteration 0*

*Step 1*

$$\text{Start with } x(0) = \begin{bmatrix} \delta_2(0) \\ \delta_3(0) \\ V_2(0) \\ V_3(0) \end{bmatrix} = \begin{bmatrix} 0 \\ 0 \\ 1 \\ 1 \end{bmatrix}$$

$$P(x(0)) = \begin{bmatrix} P_2(x(0)) \\ P_3(x(0)) \end{bmatrix} = \begin{bmatrix} 0 \\ 0 \end{bmatrix}$$

$$Q(x(0)) = \begin{bmatrix} Q_2(x(0)) \\ Q_3(x(0)) \end{bmatrix} = \begin{bmatrix} 0 \\ 0 \end{bmatrix}$$

$$\Delta y(0) = \begin{bmatrix} P_2 - P_2(x(0)) \\ P_3 - P_3(x(0)) \\ Q_2 - Q_2(x(0)) \\ Q_3 - Q_3(x(0)) \end{bmatrix} = \begin{bmatrix} 0.8 \\ -1.8 \\ 0.5 \\ 0 \end{bmatrix}$$

*Step 2*

$$J(0) = \left[ \begin{array}{cc|cc} 16 & -8 & 8 & -4 \\ -8 & 16 & -4 & 8 \\ \hline -8 & 4 & 16 & -8 \\ 4 & -8 & -8 & 16 \end{array} \right]$$

*Step 3*

$$J(0)\Delta x(0) = \Delta y(0)$$

$$\Delta x(0) = \begin{bmatrix} -0.023333 \\ -0.10167 \\ 1.03 \\ 0.97 \end{bmatrix}$$

*Step 4*

$$x(1) = x(0) + \Delta x(0) = \begin{bmatrix} -0.023333 \\ -0.10167 \\ 1.03 \\ 0.97 \end{bmatrix}$$



*Iteration 1*

*Step 1*

$$P(x(1)) = \begin{bmatrix} 0.8174 \\ -1.7299 \end{bmatrix}$$

$$Q(x(1)) = \begin{bmatrix} 0.5517 \\ 0.0727 \end{bmatrix}$$

$$\Delta y(1) = \begin{bmatrix} -0.01739 \\ -0.070052 \\ -0.051746 \\ -0.072698 \end{bmatrix}$$

*Step 2*

$$J(1) = \begin{bmatrix} 16.4227 & -8.28102 & 9.03358 & -3.46256 \\ -7.65556 & 14.9817 & -4.47535 & 5.97655 \\ -7.66981 & 3.35868 & 17.0157 & -8.53714 \\ 4.60961 & -9.25715 & -7.43258 & 15.5949 \end{bmatrix}$$

*Step 3*

$$\Delta x(1) = \begin{bmatrix} -0.00057587 \\ -0.0032484 \\ -0.0077284 \\ -0.010103 \end{bmatrix}$$

*Step 4*

$$x(2) = \begin{bmatrix} -0.023904 \\ -0.10492 \\ 1.0223 \\ 0.9599 \end{bmatrix}$$

*Iteration 2*

*Step 1*

$$P(x(2)) = \begin{bmatrix} 0.7999 \\ -1.7989 \end{bmatrix}$$

$$Q(x(2)) = \begin{bmatrix} 0.5005 \\ 0.0007 \end{bmatrix}$$

$$\Delta y(2) = \begin{bmatrix} 0.00013185 \\ -0.0011097 \\ -0.00048034 \\ -0.00072284 \end{bmatrix}$$

Step 2

$$J(2) = \begin{bmatrix} 16.2201 & -8.14207 & 8.96061 & -3.41392 \\ -7.50685 & 14.7417 & -4.44838 & 5.80513 \\ -7.56045 & 3.27701 & 16.8459 & -8.48223 \\ 4.54745 & -9.17011 & -7.34331 & 15.3591 \end{bmatrix}$$

Step 3

$$\Delta x(2) = \begin{bmatrix} -6.3502 \text{ E-7} \\ -5.3289 \text{ E-5} \\ -7.6468 \text{ E-5} \\ -0.00011525 \end{bmatrix}$$

Step 4

$$x(3) = \begin{bmatrix} -0.02391 \\ -0.10497 \\ 1.0222 \\ 0.95978 \end{bmatrix}$$

Iteration 3

Step 1

$$P(x(3)) = \begin{bmatrix} 0.8000 \\ -1.8000 \end{bmatrix}$$

$$Q(x(3)) = \begin{bmatrix} 0.5000 \\ 0.0000 \end{bmatrix}$$

$$\Delta y(3) = \begin{bmatrix} 6.1267 \text{ E-8} \\ -2.0161 \text{ E-7} \\ -6.5136 \text{ E-8} \\ -8.9553 \text{ E-8} \end{bmatrix}$$

$$\Delta y(3) < 1 \text{ E-4}$$

∴ Newton-Raphson has converged in 3 iterations to

$$V_1 = 1.0 \angle 0$$

$$V_2 = 1.0222 \angle -0.02391 \text{ rad} = 1.0222 \angle -1.370^\circ$$

$$V_3 = 0.95978 \angle -0.10497 \text{ rad} = 0.95978 \angle -6.014^\circ$$

Using the voltages, we can calculate the powers at bus 1 with Eqs. (6.6.2) and (6.6.3).

$$P_1 = 1.0944 \text{ p.u.} = 109.44 \text{ MW}$$

$$Q_1 = -0.3112 \text{ p.u.} = -31.12 \text{ Mvar}$$

Using PowerWorld Simulator, we get

$$P_1 = 109.4 \text{ MW}$$

$$Q_1 = -31.1 \text{ Mvar}$$

$$V_2 = 1.025 \text{ p.u.}$$

$$V_3 = 0.960 \text{ p.u.}$$

Which agrees with our solution.

**6.48**

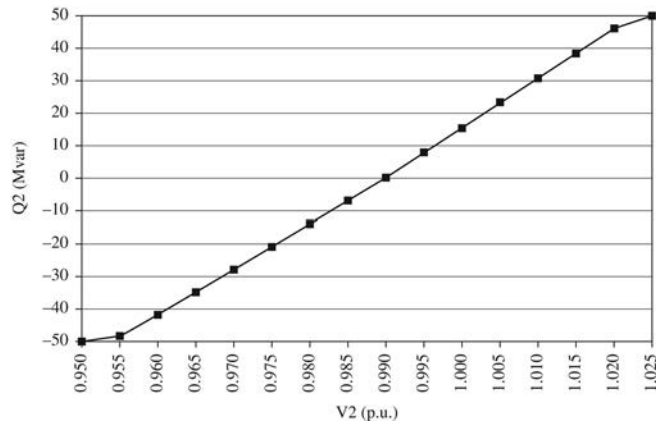

**6.49**

Tap setting	Mvar @ G1	V5 (p.u.)	V2 (p.u.)	P losses
0.975	94	0.954	0.806	37.64
0.98125	90	0.961	0.817	36.63
0.9875	98	0.965	0.823	36.00
0.99375	106	0.97	0.828	35.4
1.0	114	0.974	0.834	34.84
1.00625	123	0.979	0.839	34.31
1.0125	131	0.983	0.845	33.81
1.01875	140	0.987	0.850	33.33
1.025	149	0.992	0.855	32.89
1.03125	158	0.996	0.86	32.47
1.0375	167	1.0	0.865	32.08
1.04375	176	1.004	0.87	31.72
1.05	185	1.008	0.874	31.38
1.05625	195	1.012	0.879	31.06
1.0625	204	1.016	0.884	30.76
1.06875	214	1.02	0.888	30.49
1.075	224	1.024	0.893	30.23
1.08125	233	1.028	0.897	30.00
1.0875	243	1.031	0.901	29.79
1.09375	253	1.035	0.906	29.59
1.1	263	1.039	0.910	29.42

Shunt Capacitor State	Shunt Capacitor Rating (Mvar)	Shunt Capacitor Output (Mvar)	$V_2$ (p.u.)	Line 2-4	Line 2-5	Line 4-5	Total Power Losses (MW)
Disconnected	0	0	0.834	27%	49%	19%	34.37
Connected	200	184.0	0.959	25%	44%	16%	25.37
Connected	261	261.0	1.000	25%	43%	15%	23.95

When the capacitor rating is set at 261 Mvar, the voltage at bus 2 becomes 1.0 per unit. As a result of this, the line loadings decrease on all lines, and thus the power loss decrease as well.

	Before new line	After new line
Bus voltage $V_2$ (p.u.)	0.834	0.953
Total real power losses (MW)	34.8	18.3
Branch b/w bus 1–5 (% loading)	68.5	63.1
Branch b/w bus 2–4 (% loading)	27.3	17.5
	49.0	25.4
Branch b/w bus 2–5 (% loading)		(both lines)
Branch b/w bus 3–4 (% loading)	53.1	45.7
Branch b/w bus 4–5 (% loading)	18.8	22.1

6.52 With the line connecting HOMER 69 and LAUF 69 removed, the voltage at HANNAH 69 drops to 0.966 p.u. To raise that voltage to 1.0 p.u., we require 32.0 Mvar from the capacitor bank of HANNAH 69.

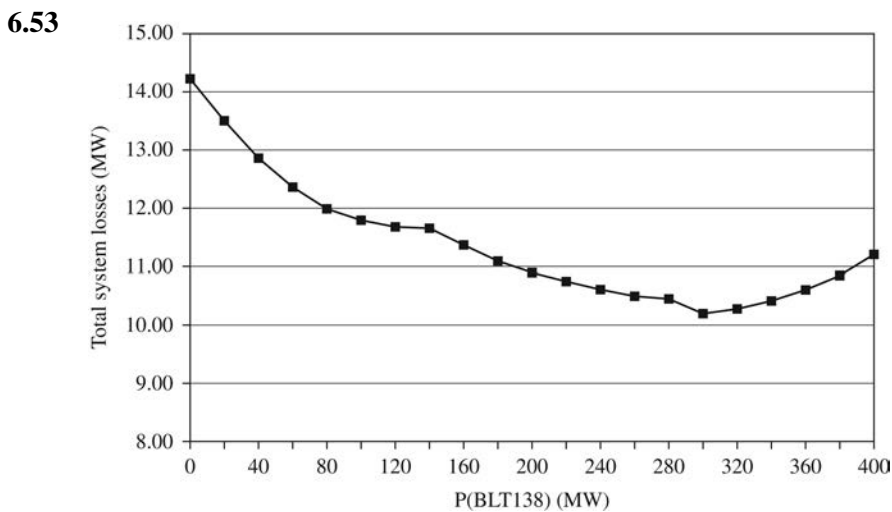

When the generation at BLT138 is 300 MW, the losses on the system are minimized to 10.24 MW.

6.54

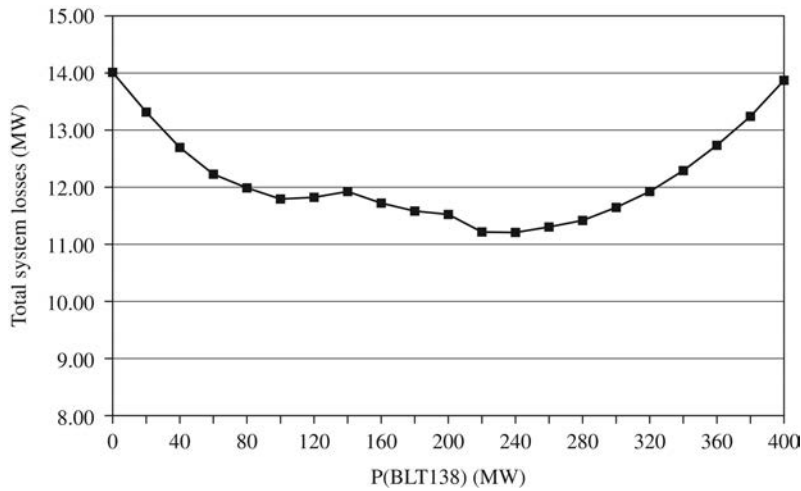

When the generation at BLT138 is 220 MW or 240 MW, the losses on the system are minimized to 11.21 MW.

6.55

$$\begin{aligned} \text{DIAG} &= [17 \ 25 \ 9 \ 2 \ 14 \ 15] \\ \text{OFFDIAG} &= [-9.1 \ -2.1 \ -7.1 \ -9.1 \ -8.1 \ -1.1 \ -6.1 \ -8.1 \ -1.1 \ -2.1 \ -6.1 \ -5.1 \ -7.1 \ -5.1] \\ \text{COL} &= [ \ 2 \ 5 \ 6 \ 1 \ 3 \ 4 \ 5 \ 2 \ 2 \ 1 \ 2 \ 6 \ 1 \ 5 ] \\ \text{ROW} &= [ \ 3 \ 4 \ 1 \ 1 \ 3 \ 2 ] \end{aligned}$$

6.56

By the process of node elimination and active branch designation, in Fig. 6.9:

Step No.	1	2	3	4	5	6	7	8	9	10
Mode eliminated	(h)	(e)	(j)	(i)	(d)	(c)	(a)	(b)	(f)	(g)
No. of active branches	1	1	2	1	1	2	2	2	1	0
Resulting fill-ins	0	0	0	0	0	0	2	0	0	0

The fill-in (dashed) branch after Step 6 is shown below:

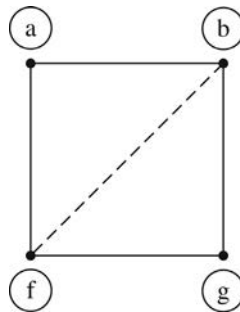

Note that two fill-ins are unavoidable. When the bus numbers are assigned to Fig. 6.9 in accordance with the step numbers above, the rows and columns of  $\bar{Y}_{BUS}$  will be optimally ordered for Gaussian elimination, and as a result, the triangular factors  $\bar{L}$  and  $\bar{U}$  will require minimum storage and computing time for solving the nodal equations.

**6.57 Table 6.6 w/DC Approximation**

Bus #	Voltage Magnitude (per unit)	Generation	Load			
		Phase Angle (degrees)	PG (per unit)	QG (per unit)	PL (per unit)	QL (per unit)
1	1.000	0.000	3.600	0.000	0.000	0.000
2	1.000	-18.695	0.000	0.000	8.000	0.000
3	1.000	0.524	5.200	0.000	0.800	0.000
4	1.000	-1.997	0.000	0.000	0.000	0.000
5	1.000	-4.125	0.000	0.000	0.000	0.000
		<b>TOTAL</b>	<b>8.800</b>	<b>0.000</b>	<b>8.800</b>	<b>0.000</b>

When comparing these results to Table 6.6 in the book, voltage magnitudes are all constant. Most phase angles are close to the NR algorithm except bus 3 has a positive angle in DC and a negative value in NR. Total generation is less since losses are not taken into account and reactive power is completely ignored in DC power flow.

**Table 6.7 w/ DC Approximation**

Line #	Bus to Bus		P	Q	S
1	2	4	-2.914	0.000	2.914
	4	2	2.914	0.000	2.914
2	2	5	-5.086	0.000	5.086
	5	2	5.086	0.000	5.086
3	4	5	1.486	0.000	1.486
	5	4	-1.486	0.000	1.486

With the DC power flow, all reactive power flows are ignored. Real power flows are close to the NR algorithm except losses are not taken into account, so each end of the line has the same flow.

**Table 6.8 w/DC Approximation**

Tran. #	Bus to Bus		P	Q	S
1	1	5	3.600	0.000	3.600
	5	1	-3.600	0.000	3.600
2	3	4	4.400	0.000	4.400
	4	3	-4.400	0.000	4.400

With DC approximation the reactive power flows in transformers are also ignored and losses are also assumed to be zero.

**6.58** With the reactance on the line from bus 2 to bus 5 changed, the B matrix becomes:

$$B = \begin{bmatrix} -43.333 & 0 & 10 & 33.333 \\ 0 & -100 & 100 & 0 \\ 10 & 100 & -150 & 40 \\ 33.333 & 0 & 40 & -123.333 \end{bmatrix}$$

$P$  remains the same:

$$P = \begin{bmatrix} -8.0 \\ 4.4 \\ 0 \\ 0 \end{bmatrix}$$

$$\delta = -B^{-1}P = \begin{bmatrix} -0.2443 \\ 0.0255 \\ -0.0185 \\ -0.0720 \end{bmatrix} \text{ rad} = \begin{bmatrix} -13.995^\circ \\ 1.4638^\circ \\ -1.0572^\circ \\ -4.1253^\circ \end{bmatrix}$$

**6.59 (a)** Since bus 7 is the slack bus, we neglect row 7 and column 7 in our  $B$  matrix and  $P$  vector.

$$B = \begin{bmatrix} -20.833 & 16.667 & 4.167 & 0 & 0 & 0 \\ 16.667 & -52.778 & 5.556 & 5.556 & 8.333 & 16.667 \\ 4.167 & 5.556 & -43.056 & 33.333 & 0 & 0 \\ 0 & 5.556 & 33.333 & -43.056 & 4.167 & 0 \\ 0 & 8.333 & 0 & 4.167 & -29.167 & 0 \\ 0 & 16.667 & 0 & 0 & 0 & -25 \end{bmatrix}$$

$$P = \begin{bmatrix} 160 \\ 110 \\ -110 \\ -30 \\ -130 \\ 0 \end{bmatrix} \text{ MW} = \begin{bmatrix} 1.6 \\ 1.1 \\ -1.1 \\ -0.3 \\ -1.3 \\ 0 \end{bmatrix} \text{ p.u.}$$

(b)  $\delta = -B^{-1}P$

$$= \begin{bmatrix} 7.6758^\circ \\ 4.2020^\circ \\ -0.4315^\circ \\ -0.3265^\circ \\ -1.3999^\circ \\ 2.8014^\circ \end{bmatrix}$$

This agrees with the angles shown in PowerWorld.

**6.60** First, we find the angle of bus 1 required to give a 65 MW line loading to the line between buses 1 and 3.

$$P_{13} = \frac{\delta_1 - \delta_3}{x_{13}}$$

$$0.65 = \frac{\delta_1 - \delta_3}{0.24}$$

$$\delta_1 = \delta_3 + 0.156$$

Now, we solve for the angles:

$$P = -B\delta$$

$$\begin{bmatrix} 1.6 + \Delta P_1 \\ 1.1 \\ -1.1 \\ -0.3 \\ -1.3 \\ 0 \end{bmatrix} = - \begin{bmatrix} & & & & & \\ & & & & & \\ & & & & & \\ & & & & & \\ & & & & & \\ & & & & & \\ & & & & & \end{bmatrix} \begin{bmatrix} \delta_3 + 0.156 \\ \delta_2 \\ \delta_3 \\ \delta_4 \\ \delta_5 \\ \delta_6 \end{bmatrix}$$

This is a system of 6 unknowns ( $\delta_2, \delta_3, \dots, \delta_6, \Delta P_1$ ) and 6 equations. Solving yields

$$\Delta P_1 = 0.3194 \text{ p.u.}$$

$$= 31.94 \text{ MW}$$

Therefore, if the generator at bus 1 increases output by 31.94 MW, the flow on the line between buses 1 and 3 will reach 100%.

**6.61** A type 1 or 2 wind turbine is one which maintains a constant real and reactive power output. Hence, the bus it is connected to will be a PQ bus. A type 3 or 4 wind turbine is one which maintains a constant voltage and real power output; the bus it is connected to will be a PV bus. In a contingency such as a line outage, the voltage in the PQ bus will change due to the redistribution of power flows on the remaining lines. However, the voltage on a PV bus remains constant in a contingency, due to the fact that the type 3 or 4 wind turbine changes its reactive power output to maintain that voltage. In this regard, a type 3 or 4 wind turbine is more favorable.

From Eq. (6.6.3), we can see that the reactive power injection at a bus is directly proportional to the voltage magnitude at that bus.





# Chapter 7

## Symmetrical Faults

### ANSWERS TO MULTIPLE-CHOICE TYPE QUESTIONS

- 7.1 Sinusoid, exponentially, the instant of short circuit
- 7.2 Time in cycles
- 7.3 Subtransient, transient
- 7.4 Direct-axis short-circuit subtransient, direct-axis short-circuit transient
- 7.5 Direct-axis synchronous reactance
- 7.6 Armature time constant
- 7.7 Leakage reactances, series reactances, constant voltage sources
- 7.8 a
- 7.9 a
- 7.10 a
- 7.11 Bus-impedance
- 7.12 a
- 7.13 Self impedances, mutual impedances
- 7.14 Elongating and cooling it
- 7.15 1500
- 7.16  $SF_6$  GAS
- 7.17 a
- 7.18 A magnetic force
- 7.19 a
- 7.20 1.0
- 7.21 Silver, sand
- 7.22 Time-current

7.1 (a)  $\bar{Z} = R + j\omega L = 0.4 + j(2\pi \cdot 60)2 \times 10^{-3} = 0.4 + j0.754$   
 $= 0.8535 \angle 62.05^\circ \Omega$

$Z = 0.8535 \Omega$  and  $\theta = 62.05^\circ$

$I_{ac} = \frac{V}{Z} = \frac{277}{0.8535} = 324.5 \text{ A}$

(b)  $I_{rms}(0) = I_{ac}k(0) = 324.5\sqrt{3} = 562.1 \text{ A}$

(c) Using Eq. (7.1.12), with  $\frac{X}{R} = \frac{0.754}{0.4} = 1.885$

$k(\tau = 5 \text{ cycles}) = \sqrt{1 - 2e^{-4\pi(5)/1.885}} \approx 1.0$

$I_{rms}(\tau = 5 \text{ cycles}) = I_{ac}k(5 \text{ cycles}) = 324.5 \text{ A}$

(d) From Eq. (7.1.1)

$V(0) = \sqrt{2}V \sin \alpha = 300; \quad \alpha = \sin^{-1}\left(\frac{300}{\sqrt{2}V}\right) = \sin^{-1}\left(\frac{300}{\sqrt{2}277}\right) = 49.98^\circ$

From Eq. (7.1.4)

$$\begin{aligned} i_{dc}(t) &= -\frac{\sqrt{2}V}{Z} \sin(\alpha - \theta)e^{-t/T} \\ &= -\frac{\sqrt{2}(277)}{0.8535} \sin(49.98^\circ - 62.05^\circ)e^{-t/T} \\ &= 95.98e^{-t/T} \end{aligned}$$

where  $T = \frac{L}{R} = \frac{2 \times 10^{-3}}{0.4} = 5 \times 10^{-3} \text{ s}$

$i_{dc}(t) = 95.98e^{-t/(5 \times 10^{-3})} \text{ A}$

7.2 (a)  $\bar{Z} = 1 + j2 = 2.236 \angle 63.43^\circ \Omega$

$I_{ac} = V/Z = 4000/2.236 = 1789 \text{ A}$

(b)  $I_{rms}(0) = 1789\sqrt{3} = 3098 \text{ A}$

(c) with  $X/R = 2$ ,  $k(5) = \sqrt{1 + 2e^{-4\pi(5)/2}} \approx 1.0$

$I_{rms}(5) = k(5)I_{ac} = (1.0)(1789) = 1789 \text{ A}$

(d)  $\alpha = \sin^{-1}\left(\frac{300}{4000\sqrt{2}}\right) = 3.04^\circ;$

$T = \frac{X}{\omega R} = \frac{2}{(2\pi \cdot 60)(1)} = 5.305 \times 10^{-3} \text{ s}$

$$\begin{aligned} i_{dc}(t) &= -\frac{\sqrt{2}(4000)}{2.236} \sin(3.04^\circ - 63.43^\circ)e^{-t/T} \\ &= 2200e^{-t/(5.305 \times 10^{-3})} \text{ A} \end{aligned}$$

**7.3**  $\bar{Z} = 0.125 + j2\pi(60)0.01 = 0.125 + j3.77 = 3.772 \angle 88.1^\circ \Omega$

$$I_{ac\ rms} = \frac{151}{\sqrt{2}} \frac{1}{3.772} = \frac{40}{\sqrt{2}} \text{ A}$$

$$T = L/R = 0.08 \text{ Sec.}$$

The response is then given by

$$i(\lambda) = 40 \sin(\omega t + \alpha - 88.1^\circ) - 40e^{-t/0.08} \sin(\alpha - 88.1^\circ)$$

(a) No dc offset, if switch is closed when  $\alpha = 88.1^\circ$ .

(b) Maximum dc offset, when  $\alpha = 88.1^\circ - 90^\circ = -1.9^\circ$

Current waveforms with no dc offset (a), and with Max. dc offset (b) are shown below:

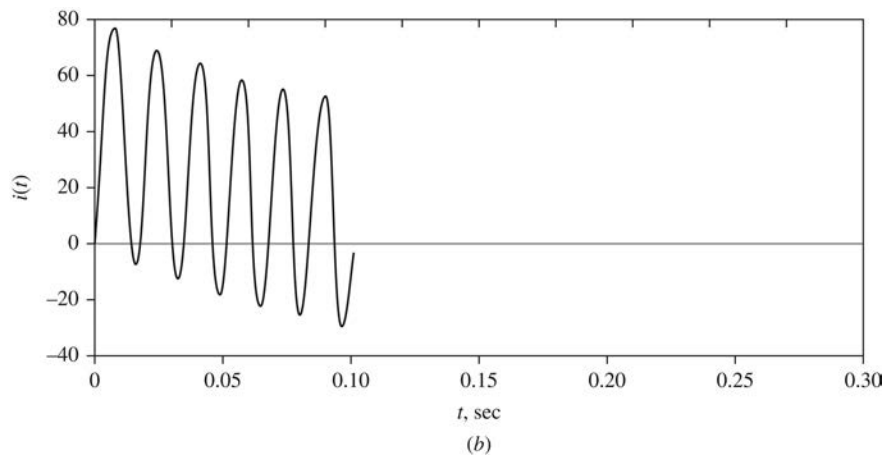
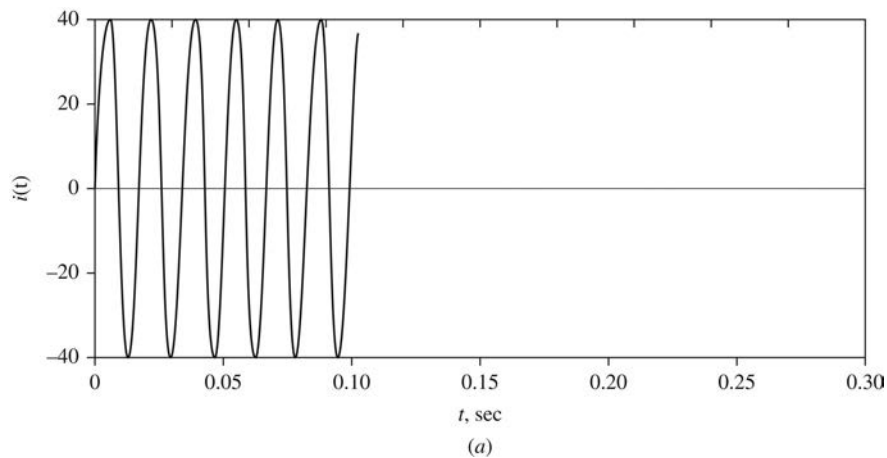

**7.4** (a) For  $X/R = 0$ ,  $i(t) = \sqrt{2} I_{rms} [\sin(\omega t - \theta_z)] \leftarrow$

(b) The wave form represents a sine wave, with  $\leftarrow$  no dc offset.

For  $X/R = \infty$ ,  $i(t) = \sqrt{2} I_{rms} [\sin(\omega t - \theta_z) + \sin \theta_z] \leftarrow$

The dc offset is maximum for  $(X/R)$  equal to infinity. ←

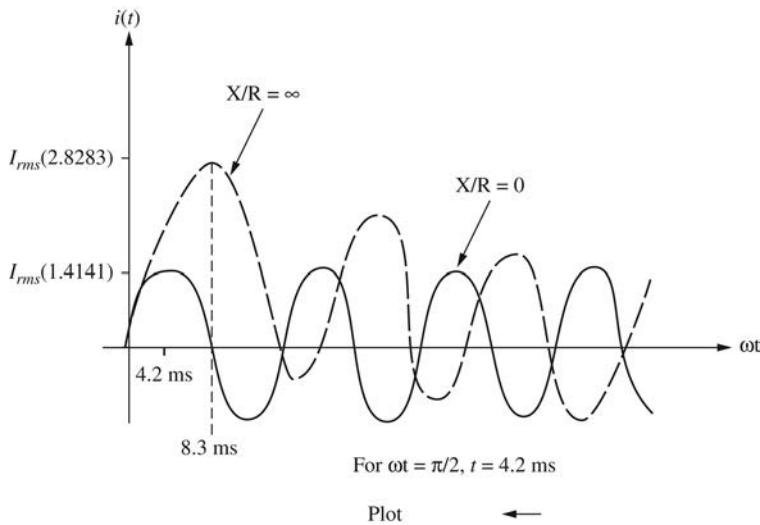

- (c) For  $(X/R) = 0$ , Asymmetrical Factor = 1.4141  
 For  $(X/R) = \infty$ , Asymmetrical Factor = 2.8283  
 The time of peak,  $t_p$ , For  $X/R = 0$ , is 4.2 ms. ←  
 and For  $X/R = \infty$ , is 8.3 ms. }

Note: The multiplying factor that is used to determine the maximum peak instantaneous fault current can be calculated by taking the derivative of the bracketed term of the given equation for  $i(t)$  in PR.7.4 with respect to time and equating to zero, and then solving for the time of maximum peak  $t_p$ ; substituting  $t_p$  into the equation, the appropriate multiplying factor can be determined.

7.5  $V_{L-N} = \frac{V_{L-L}}{\sqrt{3}} = \frac{13.2 \times 10^3}{\sqrt{3}} = 7621 \text{ V}$

RMS symmetrical fault current,  $I_{rms} = \frac{7621}{(0.5^2 + 1.5^2)^{1/2}} = 4820 \text{ A} \leftarrow$

$X/R$  Ratio of the system is  $\frac{1.5}{0.5} = 3$ , for which the asymmetrical factor is 1.9495.

∴ The maximum peak instantaneous value of fault current is  $I_{\max peak} = 1.9495(4820) = 9397 \text{ A} \leftarrow$

All substation electrical equipment must be able to withstand a peak current of approximately } ←  
 9400 A.

- 7.6 (a) Neglecting the transformer winding resistance,

$$I'' = \frac{Eq}{X_d'' + X_{TR}} = \frac{1.0}{0.17 + 0.1} = \frac{1}{0.27} = 3.704 \text{ pu}$$

The base current on the HV side of the transformer is:

$$I_{base H} = \frac{S_{rated}}{\sqrt{3} V_{rated H}} = \frac{1000}{\sqrt{3}(345)} = 1.673 \text{ kA}$$

$$I'' = 3.704 \times 1.673 = 6.198 \text{ kA}$$

- (b) Using Eq (7.2.1) at  $t = 3$  cycles = 0.05 S with the transformer reactance included,

$$I_{ac}(0.05) = 1.0 \left[ \left( \frac{1}{0.27} - \frac{1}{0.4} \right) e^{-0.05/0.05} + \left( \frac{1}{0.4} - \frac{1}{1.6} \right) e^{-0.05/1.0} + \frac{1}{1.6} \right]$$

$$= 2.851 \text{ Pu}$$

From Eq (7.2.5)

$$i_{dc}(t) = \sqrt{2}(3.704)e^{-t/0.1} = 5.238e^{-t/0.1} \text{ pu}$$

The rms asymmetrical current that the breaker interrupts is

$$I_{rms}(0.05S) = \sqrt{I_{ac}^2(0.05) + i_{dc}^2(0.05)}$$

$$= \sqrt{(2.851)^2 + (5.238)^2 e^{-2(0.05)/0.1}}$$

$$= 4.269 \text{ pu} = 4.269(1.673) = 7.144 \text{ kA}$$

- 7.7 (a) Using Eq. (7.2.1) with the transformer reactance included, and with  $\alpha = 0^\circ$  for maximum dc offset,

$$i_{ac}(t) = \sqrt{2}(1.0) \left[ \left( \frac{1}{0.27} - \frac{1}{0.4} \right) e^{-t/0.05} + \left( \frac{1}{0.4} - \frac{1}{1.6} \right) e^{-t/1.0} + \frac{1}{1.6} \right] \sin \left( \omega t - \frac{\pi}{2} \right)$$

$$= \sqrt{2} [1.204 e^{-t/0.05} + 1.875 e^{-t/1.0} + 0.625] \sin \left( \omega t - \frac{\pi}{2} \right) \text{ pu}$$

The generator base current is

$$I_{base L} = \frac{S_{rated}}{\sqrt{3} V_{rated L-L}} = \frac{1000}{\sqrt{3}(20)} = 28.87 \text{ kA}$$

$$\therefore i_{ac}(t) = 40.83 [1.204 e^{-t/0.05} + 1.875 e^{-t/1.0} + 0.625] \sin \left( \omega t - \frac{\pi}{2} \right) \text{ kA}$$

where the effect of the transformer on the time constants has been neglected.

- (b) From Eq. (7.2.5) and the results of Problem 7.6,

$$i_{dc}(t) = \sqrt{3} I'' e^{-t/T_A} = \sqrt{2}(3.704)e^{-t/0.1}$$

$$= 5.238 e^{-t/0.1} \text{ pu} = 151.2 e^{-t/0.1} \text{ kA}$$

- 7.8 (a)  $i_{ac}(t) = 10(1 + e^{-t/200} + 6e^{-t/15})$ ,  $t$  in ms and  $i$  in kA.

The plot is show below:

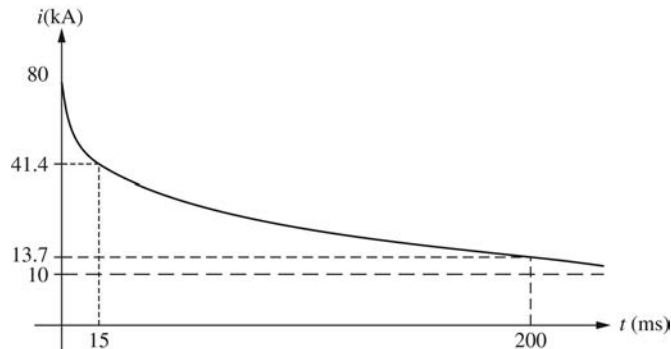

$$(b) \quad I_{base} = \frac{300}{0.0138\sqrt{3}} = 12551 \text{ A}; \quad Z_{base} = \frac{(13.8)^2}{300} = 0.635 \Omega$$

$$i(k) = 0.797(1 + e^{-t/\tau_1} + 6e^{-t/\tau_2}) \text{ pu}$$

$$\lim_{t \rightarrow \infty} i(k) = 0.797; \quad \therefore X_d = \frac{1}{0.797} = 1.255 \text{ pu}$$

$$\lim_{t \rightarrow 0} i(t) = 8 \times 0.797; \quad \therefore X_d'' = \frac{1}{8 \times 0.797} = 0.157 \text{ pu}$$

$$(c) \quad X_d = 1.255 \times 0.635 = 0.797 \Omega$$

$$X_d'' = 0.157 \times 0.635 = 0.996 \Omega$$

- 7.9 The prefault and postfault per-phase equivalent circuits are shown below:

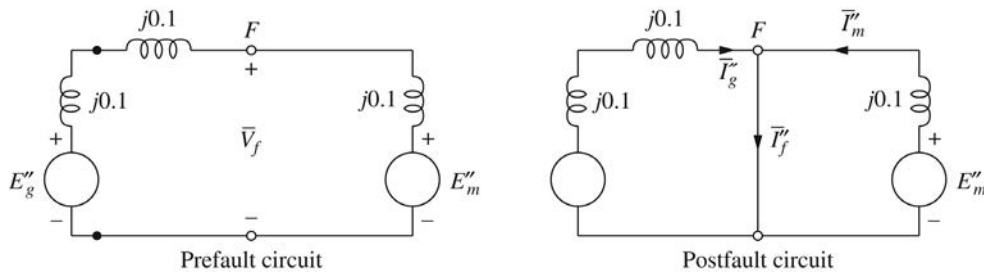

$$\bar{V}_f = \frac{14.5}{15} = 0.967 \angle 0^\circ \text{ pu, taken as reference}$$

$$\text{Base Current} = \frac{60 \times 10^6}{\sqrt{3} \times 15 \times 10^3} = 2309.5 \text{ A}$$

$$\bar{I}_{MOTOR} = \frac{40 \times 10^3 \angle 36.9^\circ}{0.8 \times \sqrt{3} \times 14.5} = 1991 \angle 36.9^\circ \text{ A}$$

$$= 0.8621 \angle 36.9^\circ \text{ pu} = (0.69 + j0.52) \text{ pu}$$

For the generator,

$$\begin{aligned}\bar{V}_t &= 0.967 + j0.1(0.69 + j0.52) = (0.915 + j0.069) \text{ pu} \\ \bar{E}_g'' &= 0.915 + j0.069 + j0.1(0.69 + j0.52) = (0.863 + j0.138) \text{ pu} \\ \bar{I}_g'' &= \frac{0.863 + j0.138}{j0.2} = (0.69 - j4.315) \text{ pu} \\ &= 2309.5(0.69 - j4.315) = (1593.6 - j9965.5) \text{ A} \leftarrow\end{aligned}$$

For the motor:

$$\begin{aligned}\bar{V}_t &= \bar{V}_f = 0.967 \angle 0^\circ \\ \bar{E}_m'' &= 0.967 - j0.1(0.69 + j0.52) = (1.019 - j0.069) \text{ pu} \\ \bar{I}_m'' &= \frac{1.019 - j0.069}{j0.1} = (-0.69 - j10.19) \text{ pu} \\ &= 2309.5(-0.69 - j10.19) = -1593.6 - j23533.8 \text{ A} \leftarrow\end{aligned}$$

$$\begin{aligned}\text{In the fault: } \bar{I}_f'' &= \bar{I}_g'' + \bar{I}_m'' = 0.69 - j4.315 - 0.69 - j10.19 \\ &= -j14.505 \text{ pu} = -j14.505 \times 2309.5 \\ &= -j33,499 \text{ A} \leftarrow\end{aligned}$$

Note: The fault current is very high since the subtransient reactance of synchronous machines and the external line reactance are low.

### 7.10

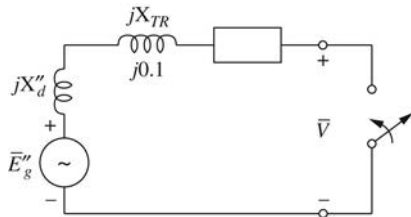

The pre-fault load current in pu is

$$\bar{I}_L = \frac{S_{pu}}{V_{pu}} \angle -\cos(\text{PF}) = \frac{1.0}{1.0} \angle -\cos^{-1}(0.8) = 1.0 \angle -36.86^\circ \text{ pu}$$

The initial generator voltage behind the subtransient reactance is

$$\begin{aligned}\bar{E}_g'' &= \bar{V} + j(X_\alpha'' + X_{TR})\bar{I}_L = 1.0 \angle 0^\circ + (j0.27)(1.0 \angle -36.86^\circ) \\ &= 1.162 + j0.216 = 1.182 \angle 10.53^\circ \text{ pu}\end{aligned}$$



The subtransient fault current is

$$\bar{I}'' = \bar{E}_g'' / j(X_d'' + X_{TR}) = 1.182 \angle 10.53^\circ / j0.27 = 4.378 \angle -79.47^\circ \text{ pu}$$

$$\bar{I}'' = 4.378(1.673) \angle -79.47^\circ = 7.326 \angle -79.47^\circ \text{ kA}$$

Alternatively, using superposition,

$$\bar{I}'' = \bar{I}_1'' + \bar{I}_2'' = \bar{I}_1'' + \bar{I}_L = 3.704 \angle -90^\circ + 1.0 \angle -36.86^\circ$$

[From Pr. 7.6 (a)]

$$\begin{aligned} \bar{I}'' &= 0.8 - j4.304 = 4.378 \angle -79.47^\circ \text{ pu} \\ &= 7.326 \angle -79.47^\circ \text{ kA} \end{aligned}$$

**7.11** The prefault load current in per unit is:

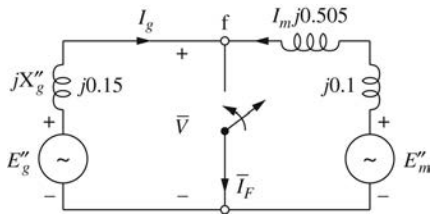

$$\bar{I}_L = \frac{S}{V} \angle -\cos^{-1}(\text{P.F.}) = \frac{1.0}{1.05} \angle -\cos^{-1} 0.95 = 0.9524 \angle -18.195^\circ \text{ per unit}$$

The internal machine voltages are:

$$\begin{aligned} \bar{E}_g'' &= \bar{V} + jX_g'' \bar{I}_L = 1.05 \angle 0^\circ + (j0.15)(0.9524 \angle -18.195^\circ) \\ &= 1.05 + 0.1429 \angle 71.81^\circ = 1.0946 + j0.1358 = 1.1030 \angle 7.072^\circ \text{ per unit} \end{aligned}$$

$$\begin{aligned} \bar{E}_m'' &= \bar{V} - j(X_{T1} + X_{Line} + X_{T2} + X_m'') \bar{I}_L \\ &= 1.05 \angle 0^\circ - (j0.505)(0.9524 \angle -18.195^\circ) \\ &= 1.05 + 0.48095 \angle -18.195^\circ = 0.8998 - j0.4569 = 1.0092 \angle -26.92^\circ \text{ per unit} \end{aligned}$$

The short circuit currents are:

$$\bar{I}_g'' = \frac{\bar{E}_g''}{jX_g''} = \frac{1.1030 \angle 7.072^\circ}{j0.15} = 7.353 \angle -82.93^\circ \text{ per unit}$$

$$\bar{I}_m'' = \frac{\bar{E}_m''}{j(X_{T1} + X_{Line} + X_{T2} + X_m'')} = \frac{1.0092 \angle -26.92^\circ}{j0.505} = 1.998 \angle 243.1^\circ \text{ per unit}$$

$$\bar{I}_F'' = \bar{I}_g'' + \bar{I}_m'' = 7.353 \angle -82.93^\circ + 1.998 \angle 243.1^\circ = -j9.079 \text{ per unit}$$

## 7.12

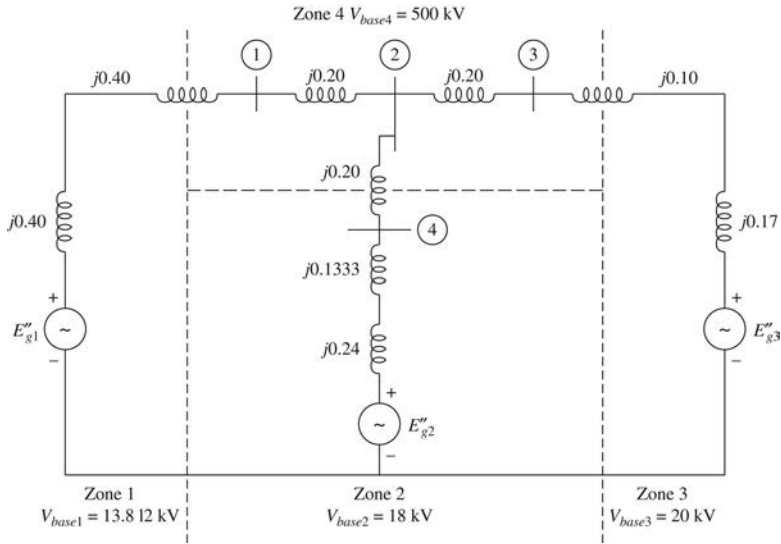

Per Unit Positive Sequence Reactance Diagram

$$X''_{g1} = (0.20) \left( \frac{1000}{500} \right) = 0.40 \text{ per unit} \quad X_{T1} = (0.12) (1000 / 500) = 0.24 \text{ per unit}$$

$$X''_{g2} = (0.18) (1000 / 750) = 0.24 \text{ Per unit} \quad X_{T2} = (0.10) (1000 / 750) = 0.1333 \text{ per unit}$$

$$X''_{g3} = 0.17 \text{ per unit} \quad X_{T3} = 0.10 \text{ per unit}$$

$$Z_{base4} = \frac{V_{base4}}{S_{base}} = \frac{(500)^2}{1000} = 250 \Omega \quad X_{Line1.2} = X_{Line2.3} = X_{Line2.4} = \frac{50}{250} = 0.20 \text{ per unit}$$

$$\begin{aligned} \text{(a)} \quad X_{Th} &= (0.40 + 0.24) // [0.20 + (0.20 + 0.10 + 0.17) // (0.20 + 0.1333 + 0.24)] \\ &= 0.64 // [0.20 + 0.47 // 0.5733] = 0.64 // 0.4583 \\ &= \underline{\underline{0.2670}} \text{ per unit} \end{aligned}$$

$$\text{(b)} \quad \bar{V}_F = \frac{525}{500} = 1.05 \angle 0^\circ \text{ per unit} \quad I_{base4} = \frac{S_{base}}{\sqrt{3} V_{base4}} = \frac{1000}{(\sqrt{3})(500)} = 1.155 \text{ kA}$$

$$\bar{I}_F'' = \frac{\bar{V}_F}{Z_{Th}} = \frac{1.05 \angle 0^\circ}{j0.2670} = \underline{\underline{-j3.933}} \text{ per unit} = (-j3.933)(1.155) = \underline{\underline{-j4.541}} \text{ kA}$$

(c) Using current division:

$$\bar{I}_{g1}'' = \bar{I}_F'' \frac{0.4583}{(0.4583 + 0.64)} = (-j3.933)(0.4173) = \underline{\underline{-j1.641}} \text{ per unit} = \underline{\underline{-j1.896}} \text{ kA}$$

$$\bar{I}_{Line1.2}'' = \bar{I}_F'' \left( \frac{0.64}{0.4583 + 0.64} \right) = (-j3.933)(0.5827) = \underline{\underline{-j2.292}} \text{ per unit} = \underline{\underline{-j2.647}} \text{ kA}$$

7.13 (a)  $X_{Th} = (0.20 + 0.24 + 0.40) // (0.20 + 0.10 + 0.17) // (0.20 + 0.1333 + 0.24)$

$$X_{Th} = 0.84 // 0.47 // 0.5733 = \frac{1}{\frac{1}{0.84} + \frac{1}{0.47} + \frac{1}{0.5733}} = 0.1975 \text{ per unit}$$

(b)  $\bar{I}_F'' = \frac{\bar{V}_F}{\bar{Z}_{Th}} = \frac{1.05 \angle 0^\circ}{j0.1975} = -j5.3155 \text{ per unit}$

$$\bar{I}_F'' = (-j5.3155)(1.155) = -j6.1379 \text{ kA}$$

(c)  $\bar{I}_{12}'' = \frac{1.05 \angle 0^\circ}{j0.84} = -j1.25 \text{ per unit} = (-j1.25)(1.155) = -j1.443 \text{ kA}$

$$\bar{I}_{32}'' = \frac{1.05 \angle 0^\circ}{j0.47} = -j2.234 \text{ per unit} = (-j2.234)(1.155) = -j2.580 \text{ kA}$$

$$\bar{I}_{42}'' = \frac{1.05 \angle 0^\circ}{j0.5733} = -j1.8315 \text{ per unit} = (-j1.8315)(1.155) = -j2.115 \text{ kA}$$

7.14 (a) Zone 1

$$V_{base1} = 10 \text{ kV}$$

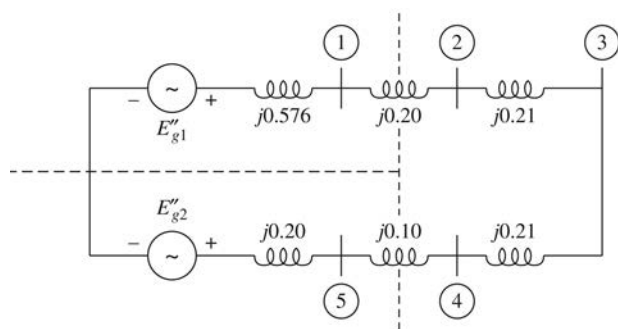

Zone 2

$$V_{base2} = 15 \text{ kV}$$

Zone 3

$$V_{base3} = 138 \text{ kV}$$

$$\bar{Z}_{base3} = \frac{(138)^2}{100} = 190.44 \Omega$$

$$X''_{g1} = (0.20) \left( \frac{12}{10} \right)^2 \left( \frac{100}{50} \right) = 0.576 \text{ per unit}$$

$$X''_{g2} = 0.20 \text{ per unit}$$

$$X_{T1} = (0.10) \left( \frac{100}{50} \right) = 0.20 \text{ per unit}$$

$$X_{T2} = 0.10 \text{ per unit} \quad X_{Line} = 40 / 190.44 = 0.21 \text{ per unit}$$

$$(b) \quad X_{Th} = (0.20) // (0.576 + 0.20 + 0.21 + 0.21 + 0.10) \\ = 0.20 // 1.296 = \underline{\underline{0.1733}} \text{ per unit}$$

$$V_F = \underline{\underline{1.0}} \text{ per unit}$$

$$(c) \quad \bar{I}_F'' = \frac{\bar{V}_F}{\bar{Z}_{Th}} = \frac{1.0 \angle 0^\circ}{j0.1733} = \underline{\underline{-j5.772}} \text{ per unit}$$

$$I_{base2} = \frac{100}{15\sqrt{3}} = 3.849 \text{ kA}$$

$$\bar{I}_F'' = (-j5.772)(3.849) = \underline{\underline{-j22.21}} \text{ kA}$$

$$(d) \quad \bar{I}_{g2}'' = \frac{1.0 \angle 0^\circ}{j0.20} = \underline{\underline{-j5.0}} \text{ per unit} = (-j5.0)(3.849) = \underline{\underline{-j19.245}} \text{ kA}$$

$$\bar{I}_{T2}'' = \frac{1.0 \angle 0^\circ}{j1.296} = \underline{\underline{-j0.7716}} \text{ per unit} = (-j0.7716)(3.849) = \underline{\underline{-j2.970}} \text{ kA}$$

$$7.15 \quad (a) \quad X_{Th} = (0.20 + 0.10) // (0.576 + 0.20 + 0.21 + 0.21) \\ = 0.30 // 1.196 = \underline{\underline{0.2398}} \text{ per unit}$$

$$(b) \quad \bar{I}_F'' = \frac{1.0 \angle 0^\circ}{j0.2398} = \underline{\underline{-j4.1695}} \text{ per unit}$$

$$I_{base3} = \frac{100}{138\sqrt{3}} = 0.4184 \text{ kA}$$

$$\bar{I}_F'' = (-j4.1695)(0.4184) = \underline{\underline{-j1.744}} \text{ kA}$$

$$(c) \quad \bar{I}_{T2}'' = \frac{1.0 \angle 0^\circ}{j0.30} = \underline{\underline{-j3.333}} \text{ per unit} = (-j3.333)(0.4184) = \underline{\underline{-j1.395}} \text{ kA}$$

$$\bar{I}_{34}'' = \frac{1.0 \angle 0^\circ}{j1.196} = \underline{\underline{-j0.836}} \text{ per unit} = (-j0.836)(0.4184) = \underline{\underline{-j0.350}} \text{ kA}$$

**7.16** Choosing base MVA as 30 MVA and the base line voltage at the HV-side of the transformer to be 33kV,

$$X_{G1} = \frac{30}{20} \times 0.15 = 0.225 \text{ pu}; X_{G2} = \frac{30}{10} \times 0.1 = 0.3 \text{ pu}; X_{TRANS} = \frac{30}{30} \times 0.05 = 0.05 \text{ pu}$$

$$\bar{Z}_{LINE} = (3 + j15) \frac{30}{33^2} = (0.0826 + j0.4132) \text{ pu}$$

The system with pu-values is shown below:

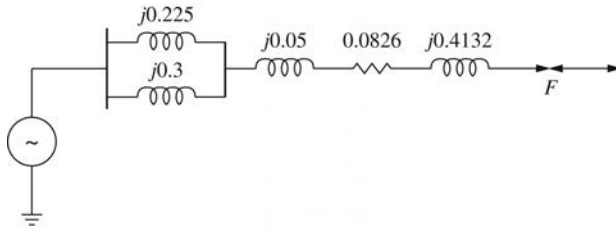

The above is reduced to:

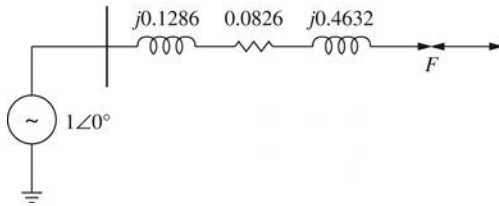

$$\bar{Z}_{TOTAL} = 0.0826 + j0.5918 = 0.5975 \angle 82^\circ \text{ pu}$$

Then

$$\bar{I}_F = \frac{1.0}{0.5975 \angle 82^\circ} = 1.674 \angle -82^\circ \text{ pu}$$

$$I_{base} = \frac{30 \times 10^6}{\sqrt{3} \times 33 \times 10} = 524.8 \text{ A}$$

$$I_F = 1.674 \times 524.8 = 878.6 \text{ A}$$

### 7.17 Choosing base values of 25 MVA and 13.8 kV on the generator side

Generator reactance = 0.15 pu

$$\text{Transformer reactance} = \frac{25 \left( \frac{13.2}{13.8} \right)^2}{25} \times 0.11 = 0.101 \text{ pu}$$

$$\text{Base voltage at the transmission line is } 13.8 \times \frac{69}{13.2} = 72.136 \text{ kV}$$

$$\text{Per-unit line reactance: } 65 \frac{25}{(72.136)^2} = 0.312$$

$$X_M = 0.15 \times \frac{25}{15} \times \left( \frac{13}{13.8} \right)^2 = 0.222 \text{ pu}$$

The reactance diagram is shown below; Switch SW simulates the short circuit, and  $\bar{E}_g''$  and  $\bar{E}_m''$  are the machine pre-fault internal voltages.

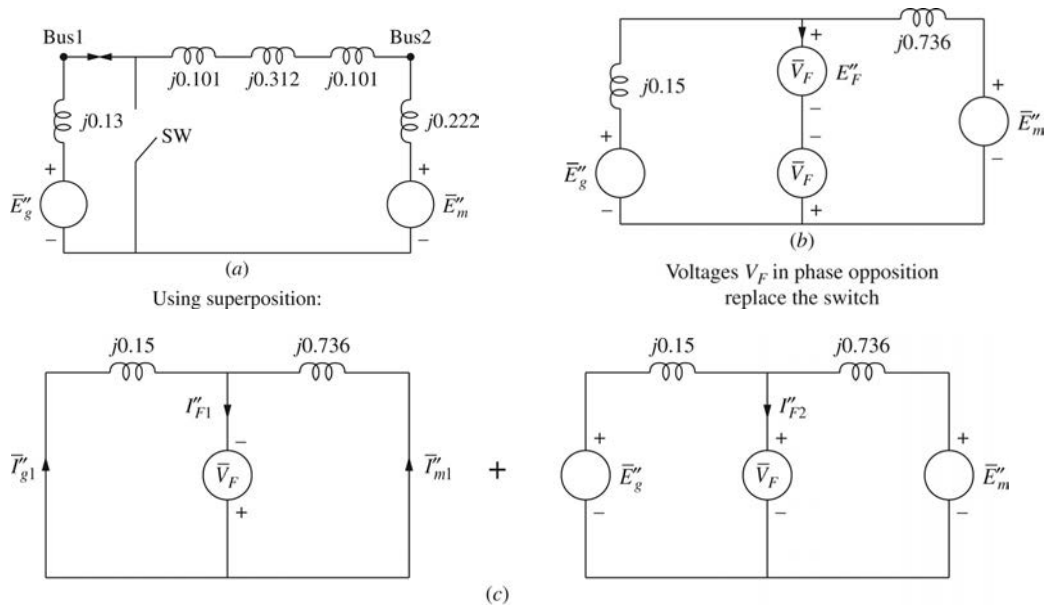

Choose  $\bar{V}_F$  to be equal to the voltage at the fault point prior to the occurrence of the fault; then  $\bar{V}_F = \bar{E}_m'' = \bar{E}_g''$ ; pre-fault currents are neglected;  $\bar{I}_{F2}'' = 0$ ; so  $\bar{V}_F$  may be open circuited as shown below:

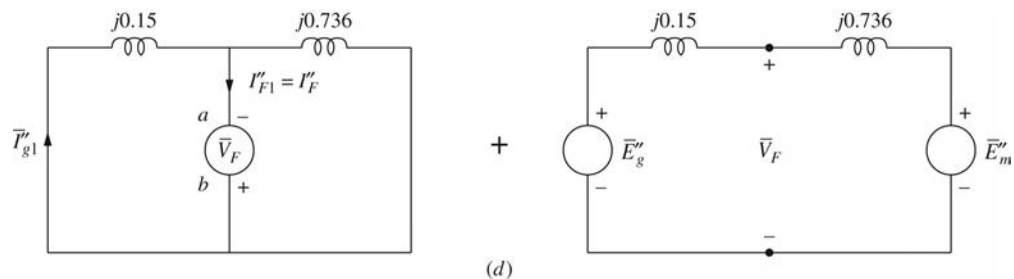

Equivalent impedance between terminals a & b is

$$\frac{j0.15 \times j0.736}{j0.15 + j0.736} = j0.1246$$

$$\therefore \bar{I}_F'' = \bar{I}_{F1}'' = \frac{1 \angle 0^\circ}{j0.1246} = -j8.025 \text{ pu}$$

Neglecting pre-fault currents,  
 $\bar{E}_g'' = \bar{E}_m'' = \bar{V}_F = 1 \angle 0^\circ \text{ pu}$

7.18 (A)

(a)

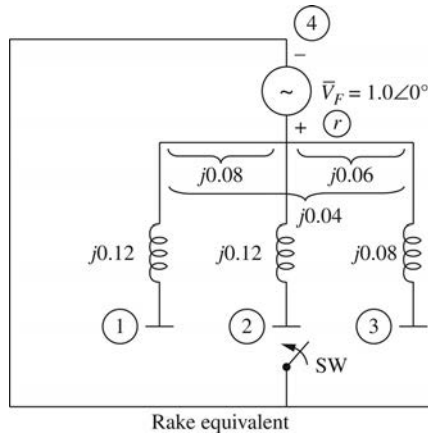

(b)  $\bar{I}_{F2}'' = \frac{\bar{V}_F}{\bar{Z}_{22}} = \frac{1.0\angle 0^\circ}{j0.12} = \underline{\underline{-j8.333}} \text{ per unit}$

Using Eq (8.4.7):

$$\bar{E}_1 = \left(1 - \frac{\bar{Z}_{12}}{\bar{Z}_{22}}\right) \bar{V}_F = \left(1 - \frac{0.08}{0.12}\right) 1.0\angle 0^\circ = \underline{\underline{0.3333\angle 0^\circ}} \text{ per unit}$$

$$\bar{E}_2 = \left(1 - \frac{\bar{Z}_{22}}{\bar{Z}_{22}}\right) \bar{V}_F = 0$$

$$\bar{E}_3 = \left(1 - \frac{\bar{Z}_{23}}{\bar{Z}_{22}}\right) \bar{V}_F = \left(1 - \frac{0.06}{0.12}\right) 1.0\angle 0^\circ = \underline{\underline{0.50\angle 0^\circ}} \text{ per unit}$$

(B)

(a)

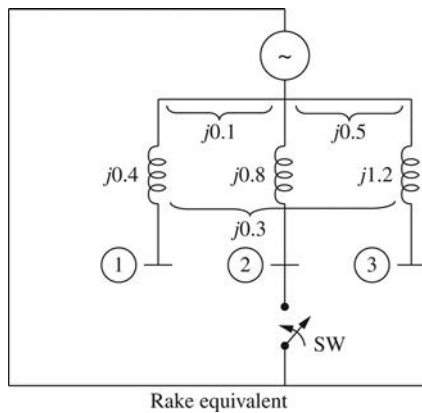

$$(b) \bar{I}_{F2}^* = \bar{V}_F / \bar{Z}_{22} = 1.0 \angle 0^\circ / j0.8 = -j1.25 \text{ pu}$$

Using Eq (7.4.7)

$$\bar{E}_1 = \left(1 - \frac{Z_{12}}{Z_{22}}\right) \bar{V}_F = \left(1 - \frac{0.1}{0.8}\right) (1 \angle 0^\circ) = 0.875 \angle 0^\circ \text{ pu}$$

$$\bar{E}_2 = \left(1 - \frac{Z_{22}}{Z_{33}}\right) \bar{V}_F = 0$$

$$\bar{E}_3 = \left(1 - \frac{Z_{23}}{Z_{33}}\right) \bar{V}_F = \left(1 - \frac{0.5}{0.8}\right) 1 \angle 0^\circ = 0.375 \angle 0^\circ \text{ pu}$$

$$7.19 \quad \bar{Y}_{BUS} = -j \begin{bmatrix} 6.5625 & -5 & 0 & 0 \\ -5 & 15 & -5 & -5 \\ 0 & -5 & 8.7037 & 0 \\ 0 & -5 & 0 & 7.6786 \end{bmatrix} \text{ per unit}$$

Using the personal computer subroutine

$$\bar{Z}_{bus} = j \begin{bmatrix} 0.2671 & 0.1505 & 0.0865 & 0.098 \\ 0.1505 & 0.1975 & 0.1135 & 0.1286 \\ 0.0865 & 0.1135 & 0.1801 & 0.0739 \\ 0.098 & 0.1286 & 0.0739 & 0.214 \end{bmatrix} \text{ per unit}$$

$$7.20 \quad \bar{Y}_{bus} = -j \begin{bmatrix} 6.7361 & -5 & 0 & 0 & 0 \\ -5 & 9.7619 & -4.7619 & 0 & 0 \\ 0 & -4.7619 & 9.5238 & -4.7619 & 0 \\ 0 & 0 & -4.7619 & 14.7619 & -10 \\ 0 & 0 & 0 & -10 & 15 \end{bmatrix} \text{ per unit}$$

Using the personal computer subroutine

$$\bar{Z}_{bus} = j \begin{bmatrix} 0.3542 & 0.2772 & 0.1964 & 0.1155 & 0.077 \\ 0.2772 & 0.3735 & 0.2645 & 0.1556 & 0.1037 \\ 0.1964 & 0.2645 & 0.3361 & 0.1977 & 0.1318 \\ 0.1155 & 0.1556 & 0.1977 & 0.2398 & 0.1599 \\ 0.077 & 0.1037 & 0.1318 & 0.1599 & 0.1733 \end{bmatrix} \text{ per unit}$$



7.21 (a) The admittance diagram is shown below:

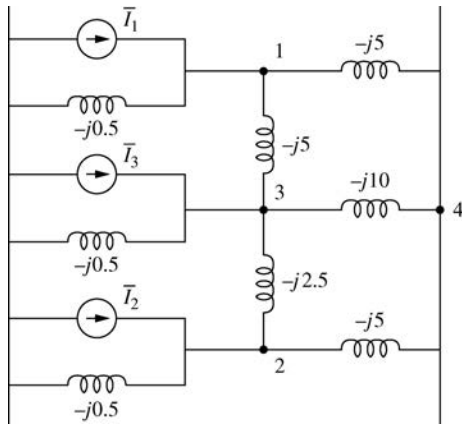

$$\begin{aligned}
 \bar{Y}_{11} &= -j0.5 - j5 - j5 = -j10.5; \bar{Y}_{22} = -j0.5 - j2.5 - j5 = -j8.0 \\
 \bar{Y}_{33} &= -j0.5 - j5 - j10 - j2.5 = -j18.0; \bar{Y}_{44} = -j5 - j10 - j5 = -j20.0 \\
 \bar{Y}_{12} = \bar{Y}_{21} &= 0; \bar{Y}_{13} = \bar{Y}_{31} = j5.0; \bar{Y}_{14} = \bar{Y}_{41} = j5.0 \\
 \bar{Y}_{23} = \bar{Y}_{32} &= j2.5; \bar{Y}_{24} = \bar{Y}_{42} = j5; \bar{Y}_{34} = \bar{Y}_{43} = j10.0
 \end{aligned}$$

Hence the bus admittance matrix is given by

$$\bar{Y}_{BUS} = \begin{bmatrix} -j10.5 & 0 & j5.0 & j5.0 \\ 0 & -j8.0 & j2.5 & j5.0 \\ j5.0 & j2.5 & -j18.0 & j10.0 \\ j5.0 & j5.0 & j10.0 & -j20.0 \end{bmatrix}$$

(c) The bus impedance matrix  $\bar{Z}_{BUS} = \bar{Y}_{BUS}^{-1}$  is given by

$$\bar{Z}_{BUS} = \begin{bmatrix} j0.724 & j0.620 & j0.656 & j0.644 \\ j0.620 & j0.738 & j0.642 & j0.660 \\ j0.656 & j0.642 & j0.702 & j0.676 \\ j0.644 & j0.660 & j0.676 & j0.719 \end{bmatrix}$$

$$\begin{array}{c}
 \text{(1)} \quad \text{(2)} \quad \text{(3)} \quad \text{(4)} \\
 \text{(1)} \left[ \begin{array}{cccc} j1.5 & -j0.25 & 0 & 0 \\ -j0.25 & j0.775 & -j0.4 & -j0.125 \\ 0 & -j0.4 & j1.85 & -j0.2 \\ 0 & -j0.125 & -j0.2 & j0.325 \end{array} \right] \\
 \text{(2)} \\
 \text{(3)} \\
 \text{(4)}
 \end{array}$$

$$(b) \bar{Z}_{BUS} = \begin{matrix} & (1) & (2) & (3) & (4) \\ \begin{matrix} (1) \\ (2) \\ (3) \\ (4) \end{matrix} & \begin{bmatrix} j0.71660 & j0.60992 & j0.53340 & j0.58049 \\ j0.60992 & j0.73190 & j0.64008 & j0.69659 \\ j0.53340 & j0.64008 & j0.71660 & j0.66951 \\ j0.58049 & j0.69659 & j0.66951 & j0.76310 \end{bmatrix} \end{matrix}$$

**Note:**  $\bar{Z}_{BUS}$  may be formulated directly (instead of inverting  $\bar{Y}_{BUS}$ ) by adding the branches in the order of their labels; and numbered subscripts on  $\bar{Z}_{BUS}$  will indicate the intermediate steps of the solution.

For details of this step-by-step method of formulating  $\bar{Z}_{BUS}$ , please refer to the 2<sup>nd</sup> edition of the text.

$$7.23 (a) \bar{I}_f'' = \frac{1.0}{\bar{Z}_{22}} = \frac{1.0}{j0.23} = -j4.348 \text{ pu} \leftarrow \text{Due to the fault}$$

**Note:** Because load currents are neglected, the prefault voltage at each bus is  $1.0 \angle 0^\circ \text{ pu}$ , the same as  $\bar{V}_f$  at bus 2.

(b) Voltages during the fault are calculated below:

$$\begin{bmatrix} \bar{V}_1 \\ \bar{V}_2 \\ \bar{V}_3 \\ \bar{V}_4 \end{bmatrix} = \begin{bmatrix} 1 - \frac{j0.2}{j0.23} \\ 0 \\ 1 - \frac{j0.15}{j0.23} \\ 1 - \frac{j0.151}{j0.23} \end{bmatrix} = \begin{bmatrix} 0.134 \\ 0 \\ 0.3478 \\ 0.3435 \end{bmatrix} \text{ pu} \leftarrow$$

(c) Current flow in line 3-1 is

$$\bar{I}_{31} = \frac{\bar{V}_3 - \bar{V}_1}{\bar{Z}_{3-1}} = \frac{0.3478 - 0.1304}{j0.25} = -j0.8696 \text{ pu} \leftarrow$$

(d) Fault currents contributed to bus 2 by the adjacent unfaulted buses are calculated below:

$$\text{From Bus 1: } \frac{\bar{V}_1}{\bar{Z}_{2-1}} = \frac{0.1304}{j0.125} = -j1.0432 \leftarrow$$

$$\text{From Bus 3: } \frac{\bar{V}_3}{\bar{Z}_{2-3}} = \frac{0.3478}{j0.25} = -j1.3912 \leftarrow$$

$$\text{From Bus 4: } \frac{\bar{V}_4}{\bar{Z}_{2-4}} = \frac{0.3435}{j0.2} = -j1.7175 \leftarrow$$

Sum of these current contributions =  $-j4.1519$

Which is approximately same as  $\bar{I}_f''$ .

- 7.24** For a fault at bus 2, generator 5 supplies 1.25 per unit current, generator 6 supplies 1.8315 pu, and generator 7 supplies 1.75 pu. The per unit fault-on voltages are bus 1 = 0.25, bus 2 = 0, bus 3 = 0.35, bus 4 = 0.3663, bus 5 = 0.55, bus 6 = 0.610, and bus 7 = 0.525.
- 7.25** For a fault at bus 1, generator 5 supplies 1.641 per unit current, generator 6 supplies 1.089 pu, and generator 7 supplies 1.040 pu. The per unit fault-on voltages are bus 1 = 0, bus 2 = 0.426, bus 3 = 0.634, bus 4 = 0.644, bus 5 = 0.394, bus 6 = 0.789, and bus 7 = 0.738.
- 7.26** For a fault midway on the line between buses 2 and 4, generator 5 supplies 0.972 per unit current, generator 6 supplies 2.218 pu, and generator 7 supplies 1.361 pu. The per unit fault-on voltages are bus 1 = 0.428, bus 2 = 0.233, bus 3 = 0.506, bus 4 = 0.222, bus 5 = 0.661, bus 6 = 0.518, and bus 7 = 0.642.
- 7.27** Generator G3 (at bus 7) supplies the most fault current for a bus 7 fault, during which it supplies 3.5 per unit fault current. This value can be limited to 2.5 per unit by increasing the G3 positive sequence impedance from 0.3 to  $1.05/2.5 = 0.42$ , which would require an addition of 0.12 per unit reactance.
- 7.28** For a three phase fault at bus 16 (PETE69), the generators supply the following per unit fault currents: 14 (WEBER69) = 0.000 (off-line), 28 (JO345) G1 = 2.934, 28 (JO345), G2=2.934, 31 (SLACK345) = 5.127, 44 (LAUF69) = 3.123, 48 (BOB69) = 0.000 (off-line), 50 (ROGER69) = 1.987, 53 (BLT138) = 8.918, 54 (BLT69) = 8.958. During the fault a total of 27 of the 37 buses have voltages at or below 0.75 per unit (one bus has a voltage of 0.74994 so some students may round this to 0.75 and say 26 buses are BELOW 0.75).
- 7.29** For a three phase fault at bus 48 (BOB69) the generators supply the following per unit fault currents: 14 (WEBER69) = 0.000 (off-line), 28 (JO345) G1 = 2.665, 28 (JO345), G2 = 2.665, 31 (SLACK345) = 4.600, 44 (LAUF69) = 2.769, 48 (BOB69) = 0.000 (off-line), 50 (ROGER69) = 2.857, 53 (BLT138) = 9.787, 54 (BLT69) = 6.410. During the fault a total of 28 of the 37 buses have voltages at or below 0.75 per unit.
- 7.30** With the generator at bus 3 open in the Example 7.5 case, all of the fault current is supplied by the generator at bus 1. The fault is 23.333 for a fault at bus 1, 10.426 for a bus 2 fault, 10.889 for bus 3, 12.149 for bus 4, and 16.154 for bus 5.

- 7.31** (a) The symmetrical interrupting capability is:

$$\text{at 10 kV: } (9.0) \left( \frac{15.5}{10} \right) = \underline{\underline{13.95 \text{ kA}}}$$

$$V_{\min} = \frac{V_{\max}}{k} = \frac{15.5}{2.67} = 5.805 \text{ kV}$$

$$\text{at 5kV: } I_{\max} = k \pm = (2.67)(9.0) = \underline{\underline{24.0 \text{ kA}}}$$

- (b) The symmetrical interrupting capability at 13.8 kV is:

$$9.0 \left( \frac{15.5}{13.8} \right) = 10.11 \text{ kA}$$

Since the interrupting capability of 10.11 kA is greater than the 10 kA symmetrical fault current and the (X/R) ratio is less than 15, the answer is **yes**. This breaker can be safely installed at the bus.

7.32 From Table 7.10, select the 500 kV (nominal voltage class) breaker with a 40 kA rated short circuit current. This breaker has a 3 kA rated continuous current.

7.33 The maximum symmetrical interrupting capability is  $k \times$  rated short-circuit current  $\bullet 1.21 \times 19,000 = 22,990$  A which must not be exceeded.

$$\begin{aligned} \text{Lower limit of operating voltage} &= \frac{\text{Rated maximum voltage}}{K} \\ &= \frac{72.5}{1.21} = 60 \text{ kV} \end{aligned}$$

Hence, in the operating voltage range 72.5–60 kV, the symmetrical interrupting current may exceed the rated short-circuit current of 19,000 A, but is limited to 22,990 A. For example, at 66 kV the interrupting current can be

$$\frac{72.5}{60} \times 19,000 = 20,871 \text{ A}$$

7.34 (a) For a base of 25 MVA, 13.8 kV in the generator circuit, the base for motors is 25 MVA, 6.9 kV. For each of the motors,

$$X_d'' = 0.2 \frac{25000}{5000} = 1.0 \text{ pu}$$

The reactance diagram is shown below:

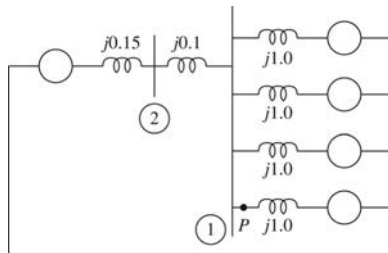

For a fault at  $P$ ,  $\bar{V}_F = 1 \angle 0^\circ \text{ pu}$ ;  $\bar{Z}_{Th} = j0.125 \text{ pu}$

$$\bar{I}_f'' = 1 \angle 0^\circ / j0.125 = -j8.0 \text{ pu}$$

The base current in the 6.9 kV circuit is  $\frac{25000}{\sqrt{3} \times 6.9} = 2090 \text{ A}$

so, subtransient fault current  $= 8 \times 2090 = 16,720 \text{ A}$

(b) Contributions from the generator and three of the four motors come through breaker A.

The generator contributes a current of  $-j8.0 \times \frac{0.25}{0.50} = -j4.0 \text{ pu}$

Each motor contributes 25% of the remaining fault current, or  $-j1.0 \text{ pu}$  amperes each.

For breaker A

$$\bar{I}'' = -j4.0 + 3(-j1.0) = -j7.0 \text{ pu or } 7 \times 2090 = 14,630 \text{ A}$$

- (c) To compute the current to be interrupted by breaker A, let us replace the sub transient reactance of  $j1.0$  by the transient reactance, say  $j1.5$ , in the motor circuit. Then

$$\bar{Z}_{Th} = j \frac{0.375 \times 0.25}{0.375 + 0.25} = j0.15 \text{ pu}$$

The generator contributes a current of

$$\frac{1.0}{j0.15} \times \frac{0.375}{0.625} = -j4.0 \text{ pu}$$

Each motor contributes a current of  $\frac{1}{4} \times \frac{1}{j0.15} \times \frac{0.25}{0.625} = -j0.67 \text{ pu}$

The symmetrical short-circuit current to be interrupted is

$$(4.0 + 3 \times 0.67) \times 2090 = 12,560 \text{ A}$$

Supposing that all the breakers connected to the bus are rated on the basis of the current into a fault on the bus, the short-circuit current interrupting rating of the breakers connected to the 6.9 kV bus must be at least

$$4 + 4 \times 0.67 = 6.67 \text{ pu, or } 6.67 \times 2090 = 13,940 \text{ A.}$$

A 14.4-kV circuit breaker has a rated maximum voltage of 15.5kV and a  $k$  of 2.67. At 15.5kV its rated short-circuits interrupting current is 8900 A. This breaker is rated for a symmetrical short-circuit interrupting current of  $2.67 \times 8900 = 23,760 \text{ A}$ , at a voltage of  $15.5/2.67 = 5.8 \text{ kV}$ .

This current is the maximum that can be interrupted even though the breaker may be in a circuit of lower voltage.

The short-circuit interrupting current rating at 6.9 kV is

$$\frac{15.5}{6.9} \times 8900 = 20,000 \text{ A}$$

The required capability of 13,940 A is well below 80% of 20,000 A, and the breaker is suitable with respect to short-circuit current.

## Chapter 8

### Symmetrical Components

#### ANSWERS TO MULTIPLE-CHOICE TYPE QUESTIONS

- 8.1 Equal,  $\pm 120^\circ$ ; equal,  $\pm 120^\circ$ ;  
equal, zero
- 8.2  $1e^{j120^\circ}$ ;  $-\frac{1}{2} + j\frac{\sqrt{3}}{2}$
- 8.3  $\bar{V}_0 + \bar{V}_1 + \bar{V}_2$ ;  $\bar{V}_0 + a^2\bar{V}_1 + a\bar{V}_2$ ;  
 $\bar{V}_0 + a\bar{V}_1 + a^2\bar{V}_2$
- 8.4  $\frac{1}{3}(\bar{V}_a + \bar{V}_b + \bar{V}_c)$ ;  $\frac{1}{3}(\bar{V}_a + a\bar{V}_b + a^2\bar{V}_c)$ ;  
 $\frac{1}{3}(\bar{V}_a + a^2\bar{V}_b + a\bar{V}_c)$
- 8.5 Zero
- 8.6 May, Never
- 8.7 a
- 8.8  $\bar{I}_a + \bar{I}_b + \bar{I}_c$ ;  $3\bar{I}_0$
- 8.9 Zero
- 8.10 a
- 8.11 a
- 8.12 a
- 8.13  $\bar{Z}_Y + \bar{Z}_n$ ;  $\bar{Z}_n$
- 8.14  $A^{-1}\bar{Z}_p A$
- 8.15 a
- 8.16  $\bar{Z}_Y + 3\bar{Z}_n$
- 8.17  $\infty$ ,  $\bar{Z}_\Delta / 3$ ,  $\bar{Z}_\Delta / 3$
- 8.18 Diagonal, uncoupled
- 8.19 Uncoupled, positive-sequence
- 8.20 Diagonal, zero
- 8.21  $\bar{Z}_{go} + 3\bar{Z}_n$
- 8.22 Positive sequence, subtransient
- 8.23 Does not
- 8.24 a
- 8.25 (i) Can, do; does not, 3  
(ii)  $e^{j30^\circ} : 1, e^{-j30^\circ} : 1$   
(iii) Do not
- 8.26 (i) Short  
(ii)  $3\bar{Z}_n$   
(iii) Open  
(iv) Short
- 8.27  $3; \bar{V}_0\bar{I}_0^* + \bar{V}_1\bar{I}_1^* + \bar{V}_2\bar{I}_2^*$

**8.1** Using the identities shown in Table 8.1

$$(a) \frac{a-1}{1+a-a^2} = \frac{-(1-a)}{(1+a+a^2)-2a^2} = \frac{(-1)\sqrt{3} \angle -30^\circ}{(-1)2 \angle 240^\circ} = \frac{\sqrt{3}}{2} \angle 90^\circ$$

$$(b) \frac{(a^2-a)+j}{ja+a^2} = \frac{-1+j}{a(j+a)} = \frac{\sqrt{2} \angle 135^\circ}{(1 \angle 120^\circ) \left( j - \frac{1}{2} + j \frac{\sqrt{3}}{2} \right)}$$

$$= \frac{\sqrt{2} \angle 15^\circ}{-\frac{1}{2} + j \left( \frac{\sqrt{3}}{2} + 1 \right)} = \frac{\sqrt{2} \angle 15^\circ}{1.932 \angle 105^\circ} = 0.7321 \angle 270^\circ$$

$$(c) (1+a)(1+a^2) = (-a^2)(-a) = a^3 = 1 \angle 0^\circ$$

$$(d) (a-a^2)(a^2-1) = (a^2-a)(1-a^2) = (\sqrt{3} \angle 270^\circ)(\sqrt{3} \angle 30^\circ) = 3 \angle 300^\circ$$

**8.2** (a)  $(a)^{10} = a(a^3)^3 = a = -\frac{1}{2} + j \frac{\sqrt{3}}{2}$

(b)  $(ja)^{10} = (j)^{10} (a)^{10} = (j)^4 (j)^4 (j)^2 (a) = -a = \frac{1}{2} - j \frac{\sqrt{3}}{2}$

(c)  $(1-a)^3 = (\sqrt{3} \angle -30^\circ)^3 = (\sqrt{3})^3 \angle -90^\circ = 0 - j3\sqrt{3}$   
 $= 0 - j5.196$

(d)  $e^a = e^{-\frac{1}{2} + j \frac{\sqrt{3}}{2}} = e^{-\frac{1}{2}} \angle \frac{\sqrt{3}}{2} \text{ radians}$   
 $= 0.6065 \angle 49.62^\circ = \underline{\underline{0.3929 + j0.4620}}$

**8.3** (a)  $\begin{bmatrix} \bar{I}_0 \\ \bar{I}_1 \\ \bar{I}_2 \end{bmatrix} = \frac{1}{3} \begin{bmatrix} 1 & 1 & 1 \\ 1 & a & a^2 \\ 1 & a^2 & a \end{bmatrix} \begin{bmatrix} 5 \angle 90^\circ \\ 5 \angle 320^\circ \\ 5 \angle 220^\circ \end{bmatrix} = \frac{5}{3} \begin{bmatrix} 1 \angle 90^\circ + 1 \angle 320^\circ + 1 \angle 220^\circ \\ 1 \angle 90^\circ + 1 \angle 80^\circ + 1 \angle 100^\circ \\ 1 \angle 90^\circ + 1 \angle 200^\circ + 1 \angle 340^\circ \end{bmatrix}$

$$= \frac{5}{3} \begin{bmatrix} 0 - j0.2856 \\ 0 + j2.97 \\ 0 + j0.316 \end{bmatrix} = \begin{bmatrix} 0.476 \angle -90^\circ \\ 4.949 \angle 90^\circ \\ 0.5266 \angle 90^\circ \end{bmatrix} \text{ A}$$

(b)  $\begin{bmatrix} \bar{I}_0 \\ \bar{I}_1 \\ \bar{I}_2 \end{bmatrix} = \frac{1}{3} \begin{bmatrix} 1 & 1 & 1 \\ 1 & a & a^2 \\ 1 & a^2 & a \end{bmatrix} \begin{bmatrix} 50 \angle 90^\circ \\ 50 \angle 0^\circ \\ 0 \end{bmatrix} = \frac{50}{3} \begin{bmatrix} 1 \angle 90^\circ + 1 \angle 0^\circ \\ 1 \angle 90^\circ + 1 \angle 120^\circ \\ 1 \angle 90^\circ + 1 \angle 240^\circ \end{bmatrix} = \begin{bmatrix} 23.57 \angle 45^\circ \\ 32.2 \angle 105^\circ \\ 8.627 \angle 165^\circ \end{bmatrix} \text{ A}$

$$\begin{aligned}
 \mathbf{8.4} \quad \begin{bmatrix} \bar{V}_{an} \\ \bar{V}_{bn} \\ \bar{V}_{cn} \end{bmatrix} &= \begin{bmatrix} 1 & 1 & 1 \\ 1 & a^2 & a \\ 1 & a & a^2 \end{bmatrix} \begin{bmatrix} 50 \angle 80^\circ \\ 100 \angle 0^\circ \\ 50 \angle 90^\circ \end{bmatrix} = 50 \begin{bmatrix} 1 \angle 80^\circ + 2 \angle 0^\circ + 1 \angle 90^\circ \\ 1 \angle 80^\circ + 2 \angle 240^\circ + 1 \angle 210^\circ \\ 1 \angle 80^\circ + 2 \angle 120^\circ + 1 \angle 330^\circ \end{bmatrix} \\
 &= 50 \begin{bmatrix} 2.174 + j1.985 \\ -1.692 - j1.247 \\ 0.0397 + j2.217 \end{bmatrix} = \begin{bmatrix} 147.2 \angle 42.4^\circ \\ 105.1 \angle 216.4^\circ \\ 110.9 \angle 88.97^\circ \end{bmatrix} \text{ V}
 \end{aligned}$$

**8.5** Eq. (8.1.12) of text:

$$\begin{aligned}
 \bar{I}_0 &= \frac{1}{3}(\bar{I}_a + \bar{I}_b + \bar{I}_c) \\
 &= \frac{1}{3}(12 \angle 0^\circ + 6 \angle -90^\circ + 8 \angle 150^\circ) = 1.69 - j0.67 = 1.82 \angle -21.5^\circ \text{ A} \leftarrow
 \end{aligned}$$

$$\begin{aligned}
 \bar{I}_1 &= \frac{1}{3}(\bar{I}_a + a\bar{I}_b + a^2\bar{I}_c) \\
 &= \frac{1}{3}(12 \angle 0^\circ + 1 \angle 120^\circ(6 \angle -90^\circ) + 1 \angle 240^\circ(8 \angle 150^\circ)) \\
 &= \frac{1}{3}(12 \angle 0^\circ + 6 \angle 30^\circ + 8 \angle 30^\circ) = 8.04 + j2.33 = 8.37 \angle 16.2^\circ \text{ A} \leftarrow
 \end{aligned}$$

$$\begin{aligned}
 \bar{I}_2 &= \frac{1}{3}(\bar{I}_a + a^2\bar{I}_b + a\bar{I}_c) \\
 &= \frac{1}{3}(12 \angle 0^\circ + 1 \angle 240^\circ(6 \angle -90^\circ) + 1 \angle 120^\circ(8 \angle 150^\circ)) \\
 &= \frac{1}{3}(12 \angle 0^\circ + 6 \angle 150^\circ + 8 \angle -90^\circ) = 2.27 - j1.67 = 2.81 \angle -36.3^\circ \leftarrow
 \end{aligned}$$

**8.6** (a) Eq. (8.1.9) of text:

$$\begin{aligned}
 \bar{V}_a &= (\bar{V}_0 + \bar{V}_1 + \bar{V}_2) \\
 &= (10 \angle 0^\circ + 80 \angle 30^\circ + 40 \angle -30^\circ) = 114 + j20 = 116 \angle 9.9^\circ \text{ V} \leftarrow
 \end{aligned}$$

$$\begin{aligned}
 \bar{V}_b &= \bar{V}_0 + a^2\bar{V}_1 + a\bar{V}_2 \\
 &= [10 \angle 0^\circ + 1 \angle 240^\circ(80 \angle 30^\circ) + 1 \angle 120^\circ(40 \angle -30^\circ)] \\
 &= (10 \angle 0^\circ + 80 \angle -90^\circ + 40 \angle 90^\circ) = 10 - j40 = 41.3 \angle -76^\circ \leftarrow
 \end{aligned}$$

$$\begin{aligned}
 \bar{V}_c &= \bar{V}_0 + a\bar{V}_1 + a^2\bar{V}_2 \\
 &= [10 \angle 0^\circ + 1 \angle 120^\circ(80 \angle 30^\circ) + 1 \angle 240^\circ(40 \angle -30^\circ)] \\
 &= (10 \angle 0^\circ + 80 \angle 150^\circ + 40 \angle -150^\circ) = -94 + j20 = 96.1 \angle 168^\circ \leftarrow
 \end{aligned}$$



$$\begin{aligned}
\text{(b) } \bar{V}_{ab} &= \bar{V}_a - \bar{V}_b = (114 + j20) - (10 - j40) = 104 + j60 = 120 \angle 30^\circ \text{ V} \leftarrow \\
\bar{V}_{bc} &= \bar{V}_b - \bar{V}_c = (10 - j40) - (-94 + j20) = 104 - j60 = 120 \angle -30^\circ \text{ V} \leftarrow \\
\bar{V}_{ca} &= \bar{V}_c - \bar{V}_a = (-94 + j20) - (114 + j20) = -208 + j0 = 208 \angle 180^\circ \text{ V} \leftarrow \\
(\bar{V}_{ab})_0 &= \frac{1}{3}(\bar{V}_{ab} + \bar{V}_{bc} + \bar{V}_{ca}) = \frac{1}{3}(120 \angle 30^\circ + 120 \angle -30^\circ + 208 \angle 180^\circ) = 0 \leftarrow \\
(\bar{V}_{ab})_1 &= \frac{1}{3}(\bar{V}_{ab} + a\bar{V}_{bc} + a^2\bar{V}_{ca}) = \frac{1}{3} \left[ \begin{array}{l} 120 \angle 30^\circ + 1 \angle 120^\circ (120 \angle -30^\circ) \\ + 1 \angle 240^\circ (208 \angle 180^\circ) \end{array} \right] \\
&= \frac{1}{3}(120 \angle 30^\circ + 120 \angle 90^\circ + 208 \angle 60^\circ) = 69.33 + j120 = 138.6 \angle 60^\circ \text{ V} \leftarrow \\
(\bar{V}_{ab})_2 &= \frac{1}{3}(\bar{V}_{ab} + a^2\bar{V}_{bc} + a(\bar{V}_{ca})) = \frac{1}{3} \left[ \begin{array}{l} 120 \angle 30^\circ + 1 \angle 240^\circ (120 \angle -30^\circ) \\ + 1 \angle 120^\circ (208 \angle 180^\circ) \end{array} \right] \\
&= \frac{1}{3}(120 \angle 30^\circ + 120 \angle 210^\circ + 208 \angle -60^\circ) = 34.67 - j60 = 69.3 \angle -60^\circ \text{ V} \leftarrow
\end{aligned}$$

$$\text{Since } (\bar{V}_{ab})_0 = \bar{V}_{a0} - \bar{V}_{b0} = 0$$

$$\text{And } (\bar{V}_{ab})_1 = \bar{V}_{a1} - \bar{V}_{b1}; (\bar{V}_{ab})_2 = \bar{V}_{a2} - \bar{V}_{b2}, \text{ we have}$$

$$\bar{V}_{L-L0} = 0; \bar{V}_{L-L1} = (\sqrt{3} \angle 30^\circ) \bar{V}_1; \bar{V}_{L-L2} = (\sqrt{3} \angle -30^\circ) \bar{V}_2$$

$$\text{Or } \bar{V}_1 = \left( \frac{1}{\sqrt{3}} \angle -30^\circ \right) \bar{V}_{L1} \text{ and } \bar{V}_2 = \left( \frac{1}{\sqrt{3}} \angle 30^\circ \right) \bar{V}_{L2}$$

Applying the above, one gets

$$\bar{V}_1 = \left( \frac{1}{\sqrt{3}} \angle -30^\circ \right) (138.6 \angle 60^\circ) = 80 \angle 30^\circ = 69.3 + j40 \leftarrow$$

$$\bar{V}_2 = \left( \frac{1}{\sqrt{3}} \angle 30^\circ \right) (69.3 \angle -60^\circ) = 40 \angle -30^\circ = 34.6 - j20 \leftarrow$$

Phase voltages are then given by

$$\bar{V}_a = \bar{V}_1 + \bar{V}_2 = 103.9 + j20 = 105.9 \angle 10.9^\circ \text{ V} \leftarrow$$

$$\begin{aligned}
\bar{V}_b &= a^2\bar{V}_1 + a\bar{V}_2 = 1 \angle 240^\circ (80 \angle 30^\circ) + 1 \angle 120^\circ (40 \angle -30^\circ) \\
&= (80 \angle -90^\circ + 40 \angle 90^\circ) = -j40 = 40 \angle -90^\circ \text{ V} \leftarrow
\end{aligned}$$

$$\begin{aligned}
\bar{V}_c &= a\bar{V}_1 + a^2\bar{V}_2 = 1 \angle 120^\circ (80 \angle 30^\circ) + 1 \angle 240^\circ (40 \angle -30^\circ) \\
&= 80 \angle 150^\circ + 40 \angle 210^\circ = -104 + j20 = 105.9 \angle 169^\circ \text{ V} \leftarrow
\end{aligned}$$

The above are not the same as in part (a)  $\leftarrow$

However, either set will result in the same line voltages. Note that the zero-sequence line voltage is always zero, even though zero-sequence phase voltage may exist. So it is not possible to construct the complete set of symmetrical components of phase voltages even when the unbalanced system of line voltages is known. But we can obtain a set with no zero-sequence voltage to represent the unbalanced system.

$$\begin{aligned}
 \mathbf{8.7} \quad \begin{bmatrix} \bar{I}_0 \\ \bar{I}_1 \\ \bar{I}_2 \end{bmatrix} &= \frac{1}{3} \begin{bmatrix} 1 & 1 & 1 \\ 1 & a & a^2 \\ 1 & a^2 & a \end{bmatrix} \begin{bmatrix} 0 \\ 1000 \angle 150^\circ \\ 1000 \angle 30^\circ \end{bmatrix} = \frac{1000}{3} \begin{bmatrix} 1 \angle 150^\circ + 1 \angle 30^\circ \\ 1 \angle 270^\circ + 1 \angle 270^\circ \\ 1 \angle 30^\circ + 1 \angle 150^\circ \end{bmatrix} \\
 &= \begin{bmatrix} 333.3 \angle 90^\circ \\ 666.7 \angle 270^\circ \\ 333.3 \angle 90^\circ \end{bmatrix} A
 \end{aligned}$$

Current to ground,  $\bar{I}_n = 3\bar{I}_0 = 1000 \angle 90^\circ A$

$$\begin{aligned}
 \mathbf{8.8} \quad \bar{V}_{ab} &= \bar{V}_a - \bar{V}_b; \quad \bar{V}_{bc} = \bar{V}_b - \bar{V}_c; \quad \bar{V}_{ca} = \bar{V}_c - \bar{V}_a \\
 \because \bar{V}_{ab} + \bar{V}_{bc} + \bar{V}_{ca} &= 0, \quad \bar{V}_{ab0} = \bar{V}_{bc0} = \bar{V}_{ca0} = 0
 \end{aligned}$$

Choosing  $\bar{V}_{ab}$  as the reference,

$$\begin{aligned}
 \bar{V}_{ab1} &= \frac{1}{3} (\bar{V}_{ab} + a\bar{V}_{bc} + a^2\bar{V}_{ca}) \\
 &= \frac{1}{3} ((\bar{V}_a - \bar{V}_b) + a(\bar{V}_b - \bar{V}_c) + a^2(\bar{V}_c - \bar{V}_a)) \\
 &= \frac{1}{3} [(\bar{V}_a + a\bar{V}_b + a^2\bar{V}_c) - (a^2\bar{V}_a + \bar{V}_b + a\bar{V}_c)] \\
 &= \frac{1}{3} [(\bar{V}_a + a\bar{V}_b + a^2\bar{V}_c) - a^2(\bar{V}_a + a\bar{V}_b + a^2\bar{V}_c)] \\
 &= \frac{1}{3} [(1-a^2)(\bar{V}_a + a\bar{V}_b + a^2\bar{V}_c)] = (1-a^2)\bar{V}_{a1} \\
 &= \sqrt{3} \bar{V}_{a1} e^{j30^\circ} \leftarrow
 \end{aligned}$$

$$\begin{aligned}
 \bar{V}_{ab2} &= \frac{1}{3} (\bar{V}_{ab} + a^2\bar{V}_{bc} + a\bar{V}_{ca}) \\
 &= \frac{1}{3} ((\bar{V}_a - \bar{V}_b) + a^2(\bar{V}_b - \bar{V}_c) + a(\bar{V}_c - \bar{V}_a)) \\
 &= \frac{1}{3} [(\bar{V}_a + a^2\bar{V}_b + a\bar{V}_c) - (a\bar{V}_a + \bar{V}_b + a^2\bar{V}_c)] \\
 &= \frac{1}{3} [(\bar{V}_a + a^2\bar{V}_b + a\bar{V}_c) - a(\bar{V}_a + a^2\bar{V}_b + a\bar{V}_c)] \\
 &= \frac{1}{3} [(1-a)(\bar{V}_a + a^2\bar{V}_b + a\bar{V}_c)] = (1-a)\bar{V}_{a2} \\
 &= \sqrt{3} \bar{V}_{a2} e^{-j30^\circ} \leftarrow
 \end{aligned}$$

**8.9** Choosing  $\bar{V}_{bc}$  as reference and following similar steps as in Pr. 8.8 solution, one can get

$$\left. \begin{aligned} \bar{V}_{bc0} = 0; \bar{V}_{bc1} = \sqrt{3}\bar{V}_{a1}e^{-j90^\circ} = -j\sqrt{3}\bar{V}_{a1}; \\ \text{and } \bar{V}_{bc2} = \sqrt{3}\bar{V}_{a2}e^{j90^\circ} = j\sqrt{3}\bar{V}_{a2} \end{aligned} \right\} \leftarrow$$

**8.10** (a) 
$$\begin{aligned} \begin{bmatrix} \bar{V}_{Lg0} \\ \bar{V}_{Lg1} \\ \bar{V}_{Lg2} \end{bmatrix} &= \frac{1}{3} \begin{bmatrix} 1 & 1 & 1 \\ 1 & a & a^2 \\ 1 & a^2 & a \end{bmatrix} \begin{bmatrix} 280\angle 0^\circ \\ 250\angle -110^\circ \\ 290\angle 130^\circ \end{bmatrix} \\ &= \frac{1}{3} \begin{bmatrix} 280\angle 0^\circ + 250\angle -110^\circ + 290\angle 130^\circ \\ 280\angle 0^\circ + 250\angle 10^\circ + 290\angle 10^\circ \\ 280\angle 0^\circ + 250\angle 130^\circ + 290\angle 250^\circ \end{bmatrix} = \begin{bmatrix} 2.696 - j4.257 \\ 270.6 + j31.26 \\ 6.706 - j27 \end{bmatrix} \\ &= \begin{bmatrix} 5.039 \angle -57.65^\circ \\ 272.4 \angle 6.59^\circ \\ 27.82 \angle -76.05^\circ \end{bmatrix} \text{ V} \end{aligned}$$

(b) 
$$\begin{aligned} \begin{bmatrix} \bar{V}_{ab} \\ \bar{V}_{bc} \\ \bar{V}_{ca} \end{bmatrix} &= \begin{bmatrix} \bar{V}_{ag} - \bar{V}_{bg} \\ \bar{V}_{bg} - \bar{V}_{cg} \\ \bar{V}_{cg} - \bar{V}_{ag} \end{bmatrix} = \begin{bmatrix} 280\angle 0^\circ - 250\angle -110^\circ \\ 250\angle -110^\circ - 290\angle 130^\circ \\ 290\angle 130^\circ - 280\angle 0^\circ \end{bmatrix} \\ &= \begin{bmatrix} 365.5 + j234.9 \\ 100.9 - j457.1 \\ -466.4 + j222.2 \end{bmatrix} = \begin{bmatrix} 434.5\angle 32.73^\circ \\ 468.1\angle -77.55^\circ \\ 516.6\angle 154.5^\circ \end{bmatrix} \text{ V} \end{aligned}$$

(c) 
$$\begin{aligned} \begin{bmatrix} \bar{V}_{LL0} \\ \bar{V}_{LL1} \\ \bar{V}_{LL2} \end{bmatrix} &= \frac{1}{3} \begin{bmatrix} 1 & 1 & 1 \\ 1 & a & a^2 \\ 1 & a^2 & a \end{bmatrix} \begin{bmatrix} 434.5\angle 32.73^\circ \\ 468.1\angle -77.55^\circ \\ 516.6\angle 154.5^\circ \end{bmatrix} \\ &= \frac{1}{3} \begin{bmatrix} 434.5\angle 32.73^\circ + 468.1\angle -77.55^\circ + 516.6\angle 154.5^\circ \\ 434.5\angle 32.73^\circ + 468.1\angle 42.55^\circ + 516.6\angle 34.5^\circ \\ 434.5\angle 32.73^\circ + 468.1\angle 162.5^\circ + 516.6\angle 274.5^\circ \end{bmatrix} = \begin{bmatrix} 0 + j0 \\ 378.9 + j281.2 \\ -13.46 - j46.44 \end{bmatrix} \\ &= \begin{bmatrix} 0 \\ 471.8\angle 36.58^\circ \\ 48.35\angle -106.2^\circ \end{bmatrix} \text{ V} = \begin{bmatrix} 0 \\ \sqrt{3}\bar{V}_{Lg1}\angle +30^\circ \\ \sqrt{3}\bar{V}_{Lg2}\angle -30^\circ \end{bmatrix} \end{aligned}$$

8.11 The circuit is shown below:

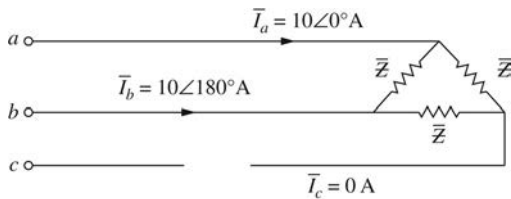

$$\bar{I}_{a0} = \frac{1}{3}(10\angle 0^\circ + 10\angle 180^\circ + 0) = 0$$

$$\bar{I}_{a1} = \frac{1}{3}(10\angle 0^\circ + 10\angle 180^\circ + 120^\circ + 0) = 5 - j2.89 = 5.78\angle -30^\circ \text{ A}$$

$$\bar{I}_{a2} = \frac{1}{3}(10\angle 0^\circ + 10\angle 180^\circ + 240^\circ + 0) = 5 + j2.89 = 5.78\angle 30^\circ \text{ A}$$

Then

$$\bar{I}_{b0} = \bar{I}_{a0} = 0 \text{ A}; \quad \bar{I}_{c0} = \bar{I}_{a0} = 0 \text{ A}$$

$$\bar{I}_{b1} = a^2 \bar{I}_{a1} = 5.78\angle -150^\circ \text{ A}; \quad \bar{I}_{c1} = a \bar{I}_{a1} = 5.78\angle 90^\circ \text{ A}$$

$$\bar{I}_{b2} = a \bar{I}_{a2} = 5.78\angle 150^\circ \text{ A}; \quad \bar{I}_{c2} = a^2 \bar{I}_{a2} = 5.78\angle -90^\circ \text{ A}$$

8.12 Note an error in printing:  $\bar{V}_{ab}$  should be  $1840\angle 82.8^\circ$  selecting a base of 2300 V and 500 kVA, each resistor has an impedance of  $1\angle 0^\circ$  pu;  $V_{ab} = 0.8$ ;  $V_{bc} = 1.2$ ;  $V_{ca} = 1.0$

The symmetrical components of the line voltages are:

$$\begin{aligned} \bar{V}_{ab1} &= \frac{1}{3}(0.8\angle 82.8^\circ + 1.2\angle 120^\circ - 41.4^\circ + 1.0\angle 240^\circ + 180^\circ) = 0.2792 + j0.9453 \\ &= 0.9857\angle 73.6^\circ \end{aligned}$$

$$\begin{aligned} \bar{V}_{ab2} &= \frac{1}{3}(0.8\angle 82.8^\circ + 1.2\angle 240^\circ - 41.4^\circ + 1.0\angle 120^\circ + 180^\circ) = -0.1790 - j0.1517 \\ &= 0.2346\angle 220.3^\circ \end{aligned}$$

(These are in pu on line-to-line voltage base.)

Phase voltages in pu on the base of voltage to neutral are given by

$$\begin{aligned} \bar{V}_{an1} &= 0.9857\angle 73.6^\circ - 30^\circ = 0.9857\angle 43.6^\circ \\ \bar{V}_{an2} &= 0.2346\angle 220.3^\circ + 30^\circ = 0.2346\angle 250.3^\circ \end{aligned} \quad [\text{Note: An angle of } 180^\circ \text{ is assigned to } \bar{V}_{ca}]$$

Zero-sequence currents are not present due to the absence of a neutral connection.

$$\bar{I}_{a1} = \bar{V}_{a1} / 1\angle 0^\circ = 0.9857\angle 43.6^\circ \text{ pu}$$

$$\bar{I}_{a2} = \bar{V}_{a2} / 1\angle 0^\circ = 0.2346\angle 250.3^\circ \text{ pu}$$

The positive direction of current is from the supply toward the load.

$$\begin{aligned}
 \mathbf{8.13} \quad (\text{a}) \quad \begin{bmatrix} I_{\Delta 0} \\ I_{\Delta 1} \\ I_{\Delta 2} \end{bmatrix} &= \frac{1}{3} \begin{bmatrix} 1 & 1 & 1 \\ 1 & a & a^2 \\ 1 & a^2 & a \end{bmatrix} \begin{bmatrix} 10 \angle 0^\circ \\ 15 \angle -90^\circ \\ 20 \angle 90^\circ \end{bmatrix} \\
 &= \frac{1}{3} \begin{bmatrix} 10 \angle 0^\circ + 15 \angle -90^\circ + 20 \angle 90^\circ \\ 10 \angle 0^\circ + 15 \angle 30^\circ + 20 \angle 330^\circ \\ 10 \angle 0^\circ + 15 \angle 150^\circ + 20 \angle 210^\circ \end{bmatrix} = \begin{bmatrix} 3.333 + j1.667 \\ 13.44 - j0.8333 \\ -6.77 - j0.8333 \end{bmatrix} = \begin{bmatrix} 3.727 \angle 26.56^\circ \\ 13.47 \angle -3.55^\circ \\ 6.821 \angle 187^\circ \end{bmatrix} \text{ A}
 \end{aligned}$$

$$(\text{b}) \quad \begin{bmatrix} \bar{I}_a \\ \bar{I}_b \\ \bar{I}_c \end{bmatrix} = \begin{bmatrix} \bar{I}_{ab} - \bar{I}_{ca} \\ \bar{I}_{bc} - \bar{I}_{ab} \\ \bar{I}_{ca} - \bar{I}_{bc} \end{bmatrix} = \begin{bmatrix} 10 \angle 0^\circ - 20 \angle 90^\circ \\ 15 \angle -90^\circ - 10 \angle 0^\circ \\ 20 \angle 90^\circ - 15 \angle -90^\circ \end{bmatrix} = \begin{bmatrix} 10 - j20 \\ -10 - j15 \\ j35 \end{bmatrix} = \begin{bmatrix} 22.36 \angle -63.43^\circ \\ 18.03 \angle 236.3^\circ \\ 35 \angle 90^\circ \end{bmatrix} \text{ A}$$

$$\begin{aligned}
 (\text{c}) \quad \begin{bmatrix} \bar{I}_{L0} \\ \bar{I}_{L1} \\ \bar{I}_{L2} \end{bmatrix} &= \frac{1}{3} \begin{bmatrix} 1 & 1 & 1 \\ 1 & a & a^2 \\ 1 & a^2 & a \end{bmatrix} \begin{bmatrix} 22.36 \angle -63.43^\circ \\ 18.03 \angle 236.3^\circ \\ 35 \angle 90^\circ \end{bmatrix} \\
 &= \frac{1}{3} \begin{bmatrix} 22.36 \angle -63.43^\circ + 18.03 \angle 236.3^\circ + 35 \angle 90^\circ \\ 22.36 \angle -63.43^\circ + 18.03 \angle 356.3^\circ + 35 \angle 330^\circ \\ 22.36 \angle -63.43^\circ + 18.03 \angle 116.3^\circ + 35 \angle 210^\circ \end{bmatrix} \\
 &= \begin{bmatrix} 0 + j0 \\ 19.43 - j12.89 \\ -9.43 - j7.112 \end{bmatrix} = \begin{bmatrix} 0 \\ 23.32 \angle -33.56^\circ \\ 11.81 \angle 217^\circ \end{bmatrix} \text{ A} = \begin{bmatrix} 0 \\ \sqrt{3} I_{\Delta 1} \angle -30^\circ \\ \sqrt{3} I_{\Delta 2} \angle +30^\circ \end{bmatrix}
 \end{aligned}$$

**8.14**

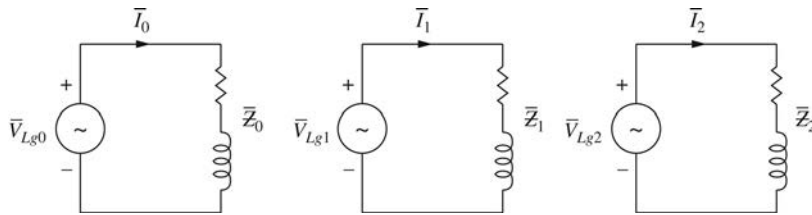

$$\bar{I}_0 = \frac{\bar{V}_{Lg0}}{\bar{Z}_0} = \frac{5.039 \angle -57.65^\circ}{20 \angle 53.13^\circ} = 0.252 \angle -110.78^\circ \text{ A}$$

$$\bar{I}_1 = \frac{\bar{V}_{Lg1}}{\bar{Z}_1} = \frac{272.4 \angle 6.59^\circ}{20 \angle 53.13^\circ} = 13.62 \angle -46.54^\circ \text{ A}$$

$$\bar{I}_2 = \frac{\bar{V}_{Lg2}}{\bar{Z}_2} = \frac{27.82 \angle -76.05^\circ}{20 \angle 53.13^\circ} = 1.391 \angle -129.18^\circ \text{ A}$$

$$\begin{aligned}
 \begin{bmatrix} \bar{I}_a \\ \bar{I}_b \\ \bar{I}_c \end{bmatrix} &= \begin{bmatrix} 1 & 1 & 1 \\ 1 & a^2 & a \\ 1 & a & a^2 \end{bmatrix} \begin{bmatrix} 0.252 \angle -110.78^\circ \\ 13.62 \angle -46.54^\circ \\ 1.391 \angle -129.18^\circ \end{bmatrix} \\
 &= \begin{bmatrix} 0.2520 \angle -110.78^\circ + 13.62 \angle -46.54^\circ + 1.391 \angle -129.18^\circ \\ 0.2520 \angle -110.78^\circ + 13.62 \angle 193.46^\circ + 1.391 \angle -9.18^\circ \\ 0.2520 \angle -110.78^\circ + 13.62 \angle 73.46^\circ + 1.391 \angle 110.82^\circ \end{bmatrix} \\
 &= \begin{bmatrix} 8.4 - j11.2 \\ -11.96 - j3.628 \\ 3.294 + j14.12 \end{bmatrix} = \begin{bmatrix} 14 \angle -53.13^\circ \\ 12.5 \angle -163.1^\circ \\ 14.5 \angle 76.37^\circ \end{bmatrix} \text{ A}
 \end{aligned}$$

Note: The source and load neutrals are connected with a zero-ohm wire.

$$\begin{bmatrix} \bar{I}_a \\ \bar{I}_b \\ \bar{I}_c \end{bmatrix} = \begin{bmatrix} \bar{V}_{ag}/\bar{z}_Y \\ \bar{V}_{bg}/\bar{z}_Y \\ \bar{V}_{cg}/\bar{z}_Y \end{bmatrix} = \begin{bmatrix} 280 \angle 0^\circ / 20 \angle 53.13^\circ \\ 250 \angle -110^\circ / 20 \angle 53.13^\circ \\ 290 \angle 130^\circ / 20 \angle 53.13^\circ \end{bmatrix} = \begin{bmatrix} 14 \angle -53.13^\circ \\ 12.5 \angle -163.1^\circ \\ 14.5 \angle 76.87^\circ \end{bmatrix}$$

Which agrees with the above result.

### 8.15

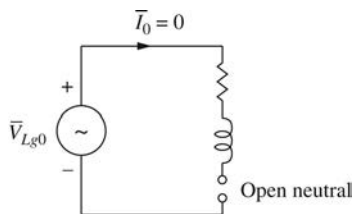

$\bar{I}_0 = 0$ ; From Problem 8.14,  $\bar{I}_1 = 13.62 \angle -46.54^\circ \text{ A}$ ;  $\bar{I}_2 = 1.391 \angle -129.18^\circ \text{ A}$

$$\begin{aligned}
 \begin{bmatrix} \bar{I}_a \\ \bar{I}_b \\ \bar{I}_c \end{bmatrix} &= \begin{bmatrix} 1 & 1 & 1 \\ 1 & a^2 & a \\ 1 & a & a^2 \end{bmatrix} \begin{bmatrix} 0 \\ 13.62 \angle -46.54^\circ \\ 1.391 \angle -129.18^\circ \end{bmatrix} \\
 &= \begin{bmatrix} 13.62 \angle -46.54^\circ + 1.391 \angle -129.18^\circ \\ 13.62 \angle 193.46^\circ + 1.391 \angle -9.18^\circ \\ 13.62 \angle 73.46^\circ + 1.391 \angle 110.82^\circ \end{bmatrix} \\
 &= \begin{bmatrix} 8.49 - j10.96 \\ -11.87 - j3.392 \\ 3.383 + j14.36 \end{bmatrix} = \begin{bmatrix} 13.86 \angle -52.24^\circ \\ 12.35 \angle 195.9^\circ \\ 14.75 \angle 76.74^\circ \end{bmatrix} \text{ A}
 \end{aligned}$$

8.16

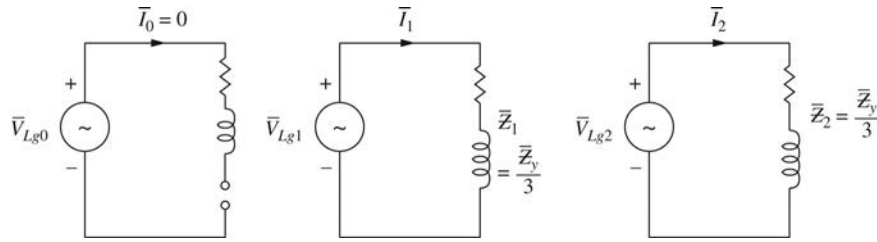

$$\bar{I}_0 = 0; \quad \bar{I}_1 = \frac{272.4 \angle 6.59^\circ}{\left(\frac{20}{3}\right) \angle 53.13^\circ} = 40.86 \angle -46.54^\circ \text{ A}$$

$$\bar{I}_2 = \frac{27.82 \angle -76.05^\circ}{\left(\frac{20}{3}\right) \angle 53.13^\circ} = 4.173 \angle -129.18^\circ \text{ A}$$

$$\begin{bmatrix} \bar{I}_a \\ \bar{I}_b \\ \bar{I}_c \end{bmatrix} = \begin{bmatrix} 1 & 1 & 1 \\ 1 & a^2 & a \\ 1 & a & a^2 \end{bmatrix} \begin{bmatrix} 0 \\ 40.86 \angle -46.54^\circ \\ 4.173 \angle -129.18^\circ \end{bmatrix} = \begin{bmatrix} 41.58 \angle -52.24^\circ \\ 37.05 \angle 195.9^\circ \\ 44.25 \angle 76.74^\circ \end{bmatrix} \text{ A}$$

Note: These currents are 3 times those in problem 8.15.

8.17  $\bar{I}_0 = \frac{\bar{V}_{Lg0}}{\bar{Z}_0} = \frac{5.039 \angle -57.65^\circ}{3 + j10} = 0.4826 \angle -131^\circ \text{ A}$

$$\bar{I}_1 = \frac{\bar{V}_{Lg1}}{\bar{Z}_1} = \frac{272.4 \angle 6.59^\circ}{7.454 \angle 26.57^\circ} = 36.54 \angle -19.98^\circ \text{ A}$$

$$\bar{I}_2 = \frac{\bar{V}_{Lg2}}{\bar{Z}_2} = \frac{27.82 \angle -76.05^\circ}{7.454 \angle 26.57^\circ} = 3.732 \angle -102.72^\circ \text{ A}$$

$$\begin{bmatrix} \bar{I}_a \\ \bar{I}_b \\ \bar{I}_c \end{bmatrix} = \begin{bmatrix} 1 & 1 & 1 \\ 1 & a^2 & a \\ 1 & a & a^2 \end{bmatrix} \begin{bmatrix} 0.4826 \angle -131^\circ \\ 36.54 \angle -19.98^\circ \\ 3.732 \angle -102.72^\circ \end{bmatrix}$$

$$= \begin{bmatrix} 0.4826 \angle -131^\circ + 36.54 \angle -19.98^\circ + 3.732 \angle -102.72^\circ \\ 0.4826 \angle -131^\circ + 36.54 \angle 220.02^\circ + 3.732 \angle 17.28^\circ \\ 0.4826 \angle -131^\circ + 36.54 \angle 100.02^\circ + 3.732 \angle 137.28^\circ \end{bmatrix}$$

$$= \begin{bmatrix} 33.2 - j16.49 \\ -24.74 - j22.75 \\ -9.416 + j38.15 \end{bmatrix} = \begin{bmatrix} 37.07 \angle -26.41^\circ \\ 33.61 \angle 222.6^\circ \\ 39.29 \angle 103.9^\circ \end{bmatrix} \text{ A}$$

$$8.18 \quad \begin{bmatrix} \bar{Z}_0 & \bar{Z}_{01} & \bar{Z}_{02} \\ \bar{Z}_{10} & \bar{Z}_1 & \bar{Z}_{12} \\ \bar{Z}_{20} & \bar{Z}_{21} & \bar{Z}_2 \end{bmatrix} = \frac{1}{3} \begin{bmatrix} 1 & 1 & 1 \\ 1 & a & a^2 \\ 1 & a^2 & a \end{bmatrix}$$

$$\begin{aligned} & \left[ \begin{array}{l} (\bar{Z}_{aa} + \bar{Z}_{ab} + \bar{Z}_{ac})(\bar{Z}_{aa} + a^2\bar{Z}_{ab} + a\bar{Z}_{ac})(\bar{Z}_{aa} + a\bar{Z}_{ab} + a^2\bar{Z}_{ac}) \\ (\bar{Z}_{ab} + \bar{Z}_{bb} + \bar{Z}_{bc})(\bar{Z}_{ab} + a^2\bar{Z}_{bb} + a\bar{Z}_{bc})(\bar{Z}_{ab} + a\bar{Z}_{bb} + a^2\bar{Z}_{bc}) \\ (\bar{Z}_{ac} + \bar{Z}_{bc} + \bar{Z}_{cc})(\bar{Z}_{ac} + a^2\bar{Z}_{bc} + a\bar{Z}_{cc})(\bar{Z}_{ac} + a\bar{Z}_{bc} + a^2\bar{Z}_{cc}) \end{array} \right] \\ &= \frac{1}{3} \left[ \begin{array}{l} (\bar{Z}_{aa} + \bar{Z}_{bb} + \bar{Z}_{cc}) + 2(\bar{Z}_{ab} + \bar{Z}_{ac} + \bar{Z}_{bc}) \\ (\bar{Z}_{aa} + a\bar{Z}_{bb} + a^2\bar{Z}_{cc}) + \bar{Z}_{ab}(1+a) + \bar{Z}_{ac}(1+a^2) + \bar{Z}_{bc}(a+a^2) \\ (\bar{Z}_{aa} + a^2\bar{Z}_{bb} + a\bar{Z}_{cc}) + \bar{Z}_{ab}(1+a^2) + \bar{Z}_{ac}(1+a) + \bar{Z}_{bc}(a^2+a) \\ (\bar{Z}_{aa} + a^2\bar{Z}_{bb} + a\bar{Z}_{cc}) + \bar{Z}_{ab}(a^2+1) + \bar{Z}_{ac}(a+1) + \bar{Z}_{bc}(a+a^2) \\ (\bar{Z}_{aa} + a^3\bar{Z}_{bb} + a^3\bar{Z}_{cc}) + \bar{Z}_{ab}(a^2+a) + \bar{Z}_{ac}(a+a^2) + \bar{Z}_{bc}(a^2+a^4) \\ (\bar{Z}_{aa} + a^4\bar{Z}_{bb} + a^2\bar{Z}_{cc}) + \bar{Z}_{ab}(a^2+a^2) + \bar{Z}_{ac}(2a) + \bar{Z}_{bc}(a^2+a^4) \\ (\bar{Z}_{aa} + a\bar{Z}_{bb} + a^2\bar{Z}_{cc}) + \bar{Z}_{ab}(1+a) + \bar{Z}_{ac}(1+a^2) + \bar{Z}_{bc}(a+a^2) \\ (\bar{Z}_{aa} + a^2\bar{Z}_{bb} + a^4\bar{Z}_{cc}) + \bar{Z}_{ab}(2a) + \bar{Z}_{ac}(2a^2) + \bar{Z}_{bc}(2) \\ (\bar{Z}_{aa} + a^3\bar{Z}_{bb} + a^3\bar{Z}_{cc}) + \bar{Z}_{ab}(a+a^2) + \bar{Z}_{ac}(a+a^2) + \bar{Z}_{bc}(a+a^2) \end{array} \right] \\ &= \frac{1}{3} \left[ \begin{array}{l} \bar{Z}_{aa} + \bar{Z}_{bb} + \bar{Z}_{cc} + 2\bar{Z}_{ab} + 2\bar{Z}_{ac} + 2\bar{Z}_{bc} \\ \bar{Z}_{aa} + a\bar{Z}_{bb} + a^2\bar{Z}_{cc} - a^2\bar{Z}_{ab} - a\bar{Z}_{ac} - \bar{Z}_{bc} \\ \bar{Z}_{aa} + a^2\bar{Z}_{bb} + a\bar{Z}_{cc} - a\bar{Z}_{ab} - a^2\bar{Z}_{ac} - \bar{Z}_{bc} \\ \bar{Z}_{aa} + a^2\bar{Z}_{bb} + a\bar{Z}_{cc} - a\bar{Z}_{ab} - a^2\bar{Z}_{ac} - \bar{Z}_{bc} \\ \bar{Z}_{aa} + \bar{Z}_{bb} + \bar{Z}_{cc} - \bar{Z}_{ab} - \bar{Z}_{ac} - \bar{Z}_{bc} \\ \bar{Z}_{aa} + a\bar{Z}_{bb} + a^2\bar{Z}_{cc} + 2a^2\bar{Z}_{ab} + 2a\bar{Z}_{ac} + 2\bar{Z}_{bc} \\ \bar{Z}_{aa} + a\bar{Z}_{bb} + a^2\bar{Z}_{cc} - a^2\bar{Z}_{ab} - a\bar{Z}_{ac} - \bar{Z}_{bc} \\ \bar{Z}_{aa} + a^2\bar{Z}_{bb} + a\bar{Z}_{cc} + 2a\bar{Z}_{ab} + 2a^2\bar{Z}_{ac} + 2\bar{Z}_{bc} \\ \bar{Z}_{aa} + \bar{Z}_{bb} + \bar{Z}_{cc} - \bar{Z}_{ab} - \bar{Z}_{ac} - \bar{Z}_{bc} \end{array} \right] \end{aligned}$$

8.19 (a)

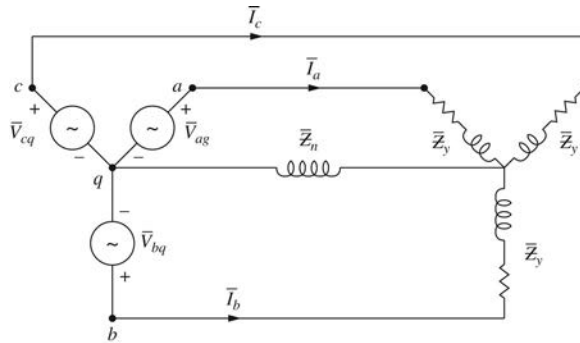



writing KVL equations [see Eqs (8.2.1) – (8.2.3)]:

$$\bar{V}_{ag} = \bar{Z}_y \bar{I}_a + \bar{Z}_n (\bar{I}_a + \bar{I}_b + \bar{I}_c)$$

$$\bar{V}_{bg} = \bar{Z}_y \bar{I}_b + \bar{Z}_n (\bar{I}_a + \bar{I}_b + \bar{I}_c)$$

$$\bar{V}_{cg} = \bar{Z}_y \bar{I}_c + \bar{Z}_n (\bar{I}_a + \bar{I}_b + \bar{I}_c)$$

In matrix format [see Eq (8.2.4)]

$$\begin{bmatrix} (\bar{Z}_y + \bar{Z}_n) & \bar{Z}_n & \bar{Z}_n \\ \bar{Z}_n & (\bar{Z}_y + \bar{Z}_n) & \bar{Z}_n \\ \bar{Z}_n & \bar{Z}_n & (\bar{Z}_y + \bar{Z}_n) \end{bmatrix} \begin{bmatrix} \bar{I}_a \\ \bar{I}_b \\ \bar{I}_c \end{bmatrix} = \begin{bmatrix} \bar{V}_{ag} \\ \bar{V}_{bg} \\ \bar{V}_{cg} \end{bmatrix}$$

$$\begin{bmatrix} (3+j5) & j_1 & j_1 \\ j_1 & (3+j5) & j_1 \\ j_1 & j_1 & (3+j5) \end{bmatrix} \begin{bmatrix} \bar{I}_a \\ \bar{I}_b \\ \bar{I}_c \end{bmatrix} = \begin{bmatrix} 100\angle 0^\circ \\ 75\angle 180^\circ \\ 50\angle 90^\circ \end{bmatrix}$$

$$\begin{bmatrix} \bar{I}_a \\ \bar{I}_b \\ \bar{I}_c \end{bmatrix} = \begin{bmatrix} (3+j5) & j_1 & j_1 \\ j_1 & (3+j5) & j_1 \\ j_1 & j_1 & (3+j5) \end{bmatrix}^{-1} \begin{bmatrix} 100\angle 0^\circ \\ 75\angle 180^\circ \\ 50\angle 90^\circ \end{bmatrix}$$

Performing the indicated matrix inverse (a computer solution is suggested):

$$\begin{bmatrix} \bar{I}_a \\ \bar{I}_b \\ \bar{I}_c \end{bmatrix} = \begin{bmatrix} 0.1763\angle -56.50^\circ & 0.02618\angle 150.2^\circ & 0.02618\angle 150.2^\circ \\ 0.02618\angle 150.2^\circ & 0.1763\angle -56.50^\circ & 0.02618\angle 150.2^\circ \\ 0.02618\angle 150.2^\circ & 0.02618\angle 150.2^\circ & 0.1763\angle -56.50^\circ \end{bmatrix} \begin{bmatrix} 100\angle 0^\circ \\ 75\angle 180^\circ \\ 50\angle 90^\circ \end{bmatrix}$$

Finally, performing the indicated matrix multiplication:

$$\begin{bmatrix} \bar{I}_a \\ \bar{I}_b \\ \bar{I}_c \end{bmatrix} = \begin{bmatrix} 17.63\angle -56.50^\circ + 1.964\angle 330.2^\circ + 1.309\angle 240.2^\circ \\ 2.618\angle 150.2^\circ + 13.22\angle 123.5^\circ + 1.309\angle 240.2^\circ \\ 2.618\angle 150.2^\circ + 1.964\angle 330.2^\circ + 8.815\angle 33.5^\circ \end{bmatrix}$$

$$\begin{bmatrix} \bar{I}_a \\ \bar{I}_b \\ \bar{I}_c \end{bmatrix} = \begin{bmatrix} 10.78 - j16.81 \\ -10.22 + j11.19 \\ 6.783 + j5.191 \end{bmatrix} = \begin{bmatrix} 19.97\angle -57.32^\circ \\ 15.15\angle 132.4^\circ \\ 8.541\angle 37.43^\circ \end{bmatrix} \text{ A}$$

(b) Step (1): Calculate the sequence components of the applied voltage:

$$\begin{aligned} \begin{bmatrix} \bar{V}_{g0} \\ \bar{V}_{g1} \\ \bar{V}_{g2} \end{bmatrix} &= \frac{1}{3} \begin{bmatrix} 1 & 1 & 1 \\ 1 & a & a^2 \\ 1 & a^2 & a \end{bmatrix} \begin{bmatrix} 100\angle 0^\circ \\ 75\angle 180^\circ \\ 50\angle 90^\circ \end{bmatrix} \\ &= \frac{1}{3} \begin{bmatrix} 100\angle 0^\circ + 75\angle 180^\circ + 50\angle 90^\circ \\ 100\angle 0^\circ + 75\angle 300^\circ + 50\angle 330^\circ \\ 100\angle 0^\circ + 75\angle 60^\circ + 50\angle 210^\circ \end{bmatrix} \\ &= \begin{bmatrix} 8.333 + j16.667 \\ 60.27 - j29.98 \\ 31.40 + j13.32 \end{bmatrix} = \begin{bmatrix} 18.63\angle 63.43^\circ \\ 67.32\angle -26.45^\circ \\ 34.11\angle 22.99^\circ \end{bmatrix} \text{ V} \end{aligned}$$

Step (2): Draw sequence networks:

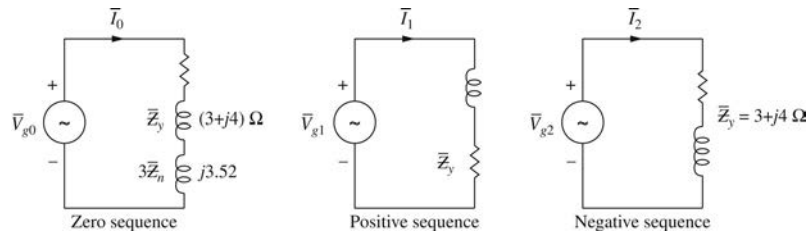

Step (3): Solve sequence networks

$$\begin{aligned} \bar{I}_0 &= \frac{\bar{V}_{g0}}{\bar{Z}_0} = \frac{\bar{V}_{g0}}{\bar{Z}_y + 3\bar{Z}_n} = \frac{18.63\angle 63.43^\circ}{3 + j7} = \frac{18.63\angle 63.43^\circ}{7.616\angle 66.80^\circ} \\ \bar{I}_0 &= 2.446\angle -3.37^\circ \text{ A} \\ \bar{I}_1 &= \frac{\bar{V}_{g1}}{\bar{Z}_1} = \frac{67.32\angle -26.45^\circ}{3 + j4} = \frac{67.32\angle -26.45^\circ}{5\angle 53.13^\circ} = 13.46\angle -79.58^\circ \text{ A} \\ \bar{I}_2 &= \frac{\bar{V}_{g2}}{\bar{Z}_2} = \frac{34.11\angle 22.99^\circ}{5\angle 53.13^\circ} = 6.822\angle -30.14^\circ \end{aligned}$$

Step (4): Calculate the line currents (phase components):

$$\begin{aligned} \begin{bmatrix} \bar{I}_a \\ \bar{I}_b \\ \bar{I}_c \end{bmatrix} &= \begin{bmatrix} 1 & 1 & 1 \\ 1 & a^2 & a \\ 1 & a & a^2 \end{bmatrix} \begin{bmatrix} 2.446\angle -3.37^\circ \\ 13.46\angle -79.58^\circ \\ 6.822\angle -30.14^\circ \end{bmatrix} \\ &= \begin{bmatrix} 2.446\angle -3.37^\circ + 13.46\angle -79.58^\circ + 6.822\angle -30.14^\circ \\ 2.446\angle -3.37^\circ + 13.46\angle 160.42^\circ + 6.822\angle 89.86^\circ \\ 2.446\angle -3.37^\circ + 13.46\angle 40.42^\circ + 6.822\angle 209.86^\circ \end{bmatrix} \\ &= \begin{bmatrix} 10.78 - j16.81 \\ -10.22 + j11.19 \\ 6.773 + j5.187 \end{bmatrix} = \begin{bmatrix} 19.97\angle -57.32^\circ \\ 15.15\angle 132.4^\circ \\ 8.531\angle 37.45^\circ \end{bmatrix} \text{ A} \end{aligned}$$

8.20 (a) The line-to-line voltages are related to the  $\Delta$  currents by

$$\begin{bmatrix} \bar{V}_{ab} \\ \bar{V}_{bc} \\ \bar{V}_{ca} \end{bmatrix} = \begin{bmatrix} j27 & 0 & 0 \\ 0 & j27 & 0 \\ 0 & 0 & j27 \end{bmatrix} \begin{bmatrix} \bar{I}_{ab} \\ \bar{I}_{bc} \\ \bar{I}_{ca} \end{bmatrix}$$

Transforming to symmetrical components,

$$A \begin{bmatrix} \bar{V}_{ab0} \\ \bar{V}_{ab1} \\ \bar{V}_{ab2} \end{bmatrix} = \begin{bmatrix} j27 & 0 & 0 \\ 0 & j27 & 0 \\ 0 & 0 & j27 \end{bmatrix} A \begin{bmatrix} \bar{I}_{ab0} \\ \bar{I}_{ab1} \\ \bar{I}_{ab2} \end{bmatrix}$$

Premultiplying each side by  $A^{-1}$ ,

$$\begin{bmatrix} \bar{V}_{ab0} \\ \bar{V}_{ab1} \\ \bar{V}_{ab2} \end{bmatrix} = j27 A^{-1} A \begin{bmatrix} \bar{I}_{ab0} \\ \bar{I}_{ab1} \\ \bar{I}_{ab2} \end{bmatrix} = \begin{bmatrix} j27 & 0 & 0 \\ 0 & j27 & 0 \\ 0 & 0 & j27 \end{bmatrix} \begin{bmatrix} \bar{I}_{ab0} \\ \bar{I}_{ab1} \\ \bar{I}_{ab2} \end{bmatrix}$$

As shown in Fig. 8.5 of the text, sequence networks for an equivalent  $Y$  representation of a balanced- $\Delta$  load are given below:

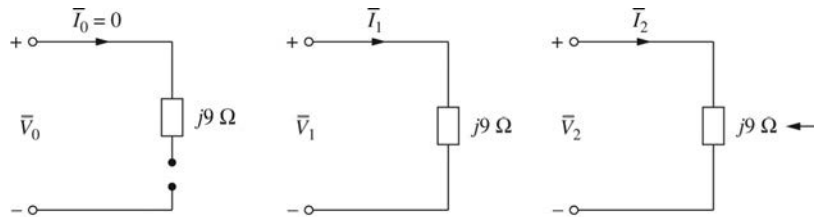

(b) With a mutual impedance of  $(j6) \Omega$  between phases,

$$A \begin{bmatrix} \bar{V}_{ab0} \\ \bar{V}_{ab1} \\ \bar{V}_{ab2} \end{bmatrix} = \begin{bmatrix} j27 & j6 & j6 \\ j6 & j27 & j6 \\ j6 & j6 & j27 \end{bmatrix} A \begin{bmatrix} \bar{I}_{ab0} \\ \bar{I}_{ab1} \\ \bar{I}_{ab2} \end{bmatrix}$$

Rewriting the coefficient matrix into two parts,

$$\begin{bmatrix} j27 & j6 & j6 \\ j6 & j27 & j6 \\ j6 & j6 & j27 \end{bmatrix} = j21 \begin{bmatrix} 1 & 0 & 0 \\ 0 & 1 & 0 \\ 0 & 0 & 1 \end{bmatrix} + j6 \begin{bmatrix} 1 & 1 & 1 \\ 1 & 1 & 1 \\ 1 & 1 & 1 \end{bmatrix}$$

and substituting into the previous equation,

$$\begin{aligned} \begin{bmatrix} \bar{V}_{ab0} \\ \bar{V}_{ab1} \\ \bar{V}_{ab2} \end{bmatrix} &= \left\{ j21A^{-1}A + jGA^{-1} \begin{bmatrix} 1 & 1 & 1 \\ 1 & 1 & 1 \\ 1 & 1 & 1 \end{bmatrix} A \right\} \begin{bmatrix} \bar{I}_{ab0} \\ \bar{I}_{ab1} \\ \bar{I}_{ab2} \end{bmatrix} \\ &= \left\{ \begin{bmatrix} j21 & 0 & 0 \\ 0 & j21 & 0 \\ 0 & 0 & j21 \end{bmatrix} + j6 \begin{bmatrix} 3 & 0 & 0 \\ 0 & 0 & 0 \\ 0 & 0 & 0 \end{bmatrix} \right\} \begin{bmatrix} \bar{I}_{ab0} \\ \bar{I}_{ab1} \\ \bar{I}_{ab2} \end{bmatrix} \\ &= \begin{bmatrix} j39 & 0 & 0 \\ 0 & j21 & 0 \\ 0 & 0 & j21 \end{bmatrix} \begin{bmatrix} \bar{I}_{ab0} \\ \bar{I}_{ab1} \\ \bar{I}_{ab2} \end{bmatrix} \end{aligned}$$

Then the sequence networks are given by:

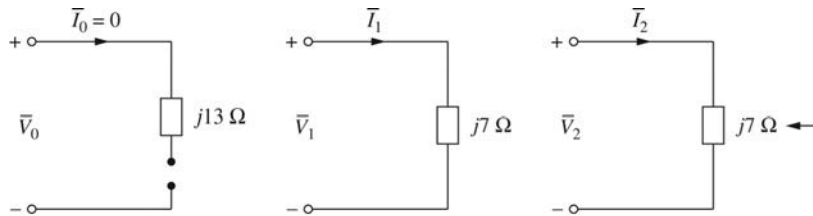

**8.21** From Eq.(8.2.28) and (8.2.29), the load is symmetrical.

Using Eq. (8.2.31) and (8.2.32):

$$\begin{aligned} \bar{Z}_0 &= \bar{Z}_{aa} + 2\bar{Z}_{ab} = 6 + j10 \Omega \\ \bar{Z}_1 &= \bar{Z}_2 = \bar{Z}_{aa} - \bar{Z}_{ab} = 6 + j10 \Omega \\ \bar{Z}_s &= \begin{bmatrix} 6 + j10 & 0 & 0 \\ 0 & 6 + j10 & 0 \\ 0 & 0 & 6 + j10 \end{bmatrix} \Omega \end{aligned}$$

**8.22** Since  $\bar{Z}_s$  is diagonal, the load is symmetrical.

Using Eq.(8.2.31) and (8.2.32):

$$\begin{aligned} \bar{Z}_0 &= 8 + j12 = \bar{Z}_{aa} + 2\bar{Z}_{ab} \\ \bar{Z}_1 &= 4 = \bar{Z}_{aa} - \bar{Z}_{ab} \end{aligned}$$

Solving the above two equations

$$\begin{aligned} \bar{Z}_{aa} &= \frac{1}{3}(8 + j12 - 4) = \frac{1}{3}(4 + j12) = \frac{4}{3} + j4 \Omega \\ \bar{Z}_{ab} &= \bar{Z}_{ab} + 4 = \frac{16}{3} + j4 \Omega \end{aligned}$$

$$\bar{\mathbf{Z}}_p = \begin{bmatrix} \frac{16}{3} + j4 & \frac{4}{3} + j4 & \frac{4}{3} + j4 \\ \frac{4}{3} + j4 & \frac{16}{3} + j4 & \frac{4}{3} + j4 \\ \frac{4}{3} + j4 & \frac{4}{3} + j4 & \frac{16}{3} + j4 \end{bmatrix} \Omega$$

**8.23** The line-to-ground voltages are

$$\bar{V}_a = \bar{Z}_s \bar{I}_a + \bar{Z}_m \bar{I}_b + \bar{Z}_m \bar{I}_c + \bar{Z}_n \bar{I}_n$$

$$\bar{V}_b = \bar{Z}_m \bar{I}_a + \bar{Z}_s \bar{I}_b + \bar{Z}_m \bar{I}_c + \bar{Z}_n \bar{I}_n$$

$$\bar{V}_c = \bar{Z}_m \bar{I}_a + \bar{Z}_m \bar{I}_b + \bar{Z}_s \bar{I}_c + \bar{Z}_n \bar{I}_n$$

Since  $\bar{I}_n = \bar{I}_a + \bar{I}_b + \bar{I}_c$ , it follows

$$\begin{bmatrix} \bar{V}_a \\ \bar{V}_b \\ \bar{V}_c \end{bmatrix} = \underbrace{\begin{bmatrix} \bar{Z}_s + \bar{Z}_n & \bar{Z}_m + \bar{Z}_n & \bar{Z}_m + \bar{Z}_n \\ \bar{Z}_m + \bar{Z}_n & \bar{Z}_s + \bar{Z}_n & \bar{Z}_m + \bar{Z}_n \\ \bar{Z}_m + \bar{Z}_n & \bar{Z}_m + \bar{Z}_n & \bar{Z}_s + \bar{Z}_n \end{bmatrix}}_{\text{phase impedance matrix } \bar{\mathbf{Z}}_p} \begin{bmatrix} \bar{I}_a \\ \bar{I}_b \\ \bar{I}_c \end{bmatrix}$$

or in compact form  $\bar{\mathbf{V}}_p = \bar{\mathbf{Z}}_p \bar{\mathbf{I}}_p$

Form Eq. (8.2.9)  $\bar{\mathbf{Z}}_s = A^{-1} \bar{\mathbf{Z}}_p A$

$$\begin{aligned} \therefore \bar{\mathbf{Z}}_s &= \frac{1}{3} \begin{bmatrix} 1 & 1 & 1 \\ 1 & a & a^2 \\ 1 & a^2 & a \end{bmatrix} \begin{bmatrix} \bar{Z}_s + \bar{Z}_n & \bar{Z}_m + \bar{Z}_n & \bar{Z}_m + \bar{Z}_n \\ \bar{Z}_m + \bar{Z}_n & \bar{Z}_s + \bar{Z}_n & \bar{Z}_m + \bar{Z}_n \\ \bar{Z}_m + \bar{Z}_n & \bar{Z}_m + \bar{Z}_n & \bar{Z}_s + \bar{Z}_n \end{bmatrix} \begin{bmatrix} 1 & 1 & 1 \\ 1 & a^2 & a \\ 1 & a & a^2 \end{bmatrix} \\ &= \underbrace{\begin{bmatrix} \bar{Z}_s + 3\bar{Z}_n + 2\bar{Z}_m & 0 & 0 \\ 0 & \bar{Z}_s - \bar{Z}_m & 0 \\ 0 & 0 & \bar{Z}_s - \bar{Z}_m \end{bmatrix}}_{\text{Sequence impedance matrix}} \end{aligned}$$

When there is no mutual coupling,  $\bar{Z}_m = 0$

$$\therefore \bar{\mathbf{Z}}_s = \begin{bmatrix} \bar{Z}_s + 3\bar{Z}_n & 0 & 0 \\ 0 & \bar{Z}_s & 0 \\ 0 & 0 & \bar{Z}_s \end{bmatrix}$$

8.24 (a) The circuit is shown below:

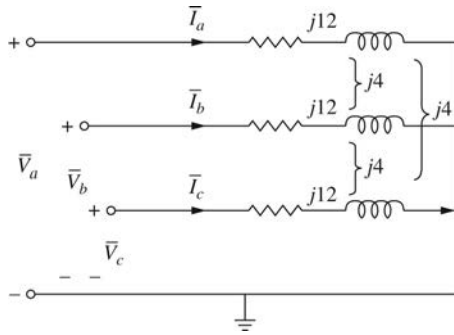

$$\begin{aligned} \text{KVL: } (j12)\bar{I}_a + (j4)\bar{I}_b - (j12)\bar{I}_b - j4(I_a) &= \bar{V}_a - \bar{V}_b = V_{LINE} \angle 30^\circ \\ (j12)\bar{I}_b + (j4)\bar{I}_c - (j12)\bar{I}_c - (j4)\bar{I}_b &= \bar{V}_b - \bar{V}_c = V_{LINE} \angle -90^\circ \end{aligned}$$

$$\text{KCL: } \bar{I}_a + \bar{I}_b + \bar{I}_c = 0$$

In matrix form:

$$\begin{bmatrix} j12 - j4 & -(j12 - j4) & 0 \\ 0 & (j12 - j4) & -(j12 - j4) \\ 1 & 1 & 1 \end{bmatrix} \begin{bmatrix} \bar{I}_a \\ \bar{I}_b \\ \bar{I}_c \end{bmatrix} = \begin{bmatrix} V_L \angle 30^\circ \\ V_L \angle 90^\circ \\ 0 \end{bmatrix}$$

where  $V_L = 100\sqrt{3}$

Solving for  $\bar{I}_a, \bar{I}_b, \bar{I}_c$ , one gets  $\bar{I}_a = 12.5 \angle -90^\circ$ ;  $\bar{I}_b = 12.5 \angle 150^\circ$ ;  $\bar{I}_c = 12.5 \angle 30^\circ$  A

(b) Using symmetrical components,

$$\bar{V}_s = \begin{bmatrix} 0 \\ 100 \\ 0 \end{bmatrix}; \bar{Z}_s = \begin{bmatrix} j12 + 2(j4) & 0 & 0 \\ 0 & j12 - j4 & 0 \\ 0 & 0 & j12 - j4 \end{bmatrix}$$

From the solution of Prob. 8.18 upon substituting the values

$$\bar{I}_s = \bar{Z}_s^{-1} \bar{V}_s \text{ and } \bar{I}_p = A \bar{I}_s \text{ where } A = \begin{bmatrix} 1 & 1 & 1 \\ 1 & a^2 & a \\ 1 & a & a^2 \end{bmatrix}$$

which result in

$$\bar{I}_a = 12.5 \angle -90^\circ; \bar{I}_b = 12.5 \angle 150^\circ; \bar{I}_c = 12.5 \angle 30^\circ \text{ A}$$

which is same as in (a)

$$8.25 \quad (a) \quad \bar{Z}_s = A^{-1} \bar{Z}_p A; A = \begin{bmatrix} 1 & 1 & 1 \\ 1 & a^2 & a \\ 1 & a & a^2 \end{bmatrix}; A^{-1} = \frac{1}{3} \begin{bmatrix} 1 & 1 & 1 \\ 1 & a & a^2 \\ 1 & a^2 & a \end{bmatrix}$$

The load sequence impedance matrix comes out as

$$\bar{Z}_s = \begin{bmatrix} 8 + j32 & 0 & 0 \\ 0 & 8 + j20 & 0 \\ 0 & 0 & 8 + j20 \end{bmatrix} \Omega$$

see the result of PR. 8.18

$$(b) \quad \bar{V}_p = \begin{bmatrix} 200 \angle 25^\circ \\ 100 \angle -155^\circ \\ 80 \angle 100^\circ \end{bmatrix}; \bar{V}_s = A^{-1} \bar{V}_p; A^{-1} = \frac{1}{3} \begin{bmatrix} 1 & 1 & 1 \\ 1 & a & a^2 \\ 1 & a^2 & a \end{bmatrix}$$

Symmetrical components of the line-to-neutral voltages are given by:

$$\bar{V}_0 = 47.7739 \angle 57.6268^\circ; \bar{V}_1 = 112.7841 \angle -0.0331^\circ; \bar{V}_2 = 61.6231 \angle 45.8825^\circ V$$

$$(c) \quad \bar{V}_s = \bar{Z}_s \bar{I}_s; \bar{I}_s = \bar{Z}_s^{-1} \bar{V}_s, \text{ which results in}$$

$$\bar{I}_0 = 1.4484 \angle -18.3369^\circ; \bar{I}_1 = 5.2359 \angle -68.2317^\circ; \bar{I}_2 = 2.8608 \angle -22.3161^\circ A$$

$$(d) \quad \bar{I}_p = A \bar{I}_s; A = \begin{bmatrix} 1 & 1 & 1 \\ 1 & a^2 & a \\ 1 & a & a^2 \end{bmatrix}$$

The result is:

$$\bar{I}_a = 8.7507 \angle -47.0439^\circ; \bar{I}_b = 5.2292 \angle 143.2451^\circ; \bar{I}_c = 3.0280 \angle 39.0675^\circ A$$

8.26

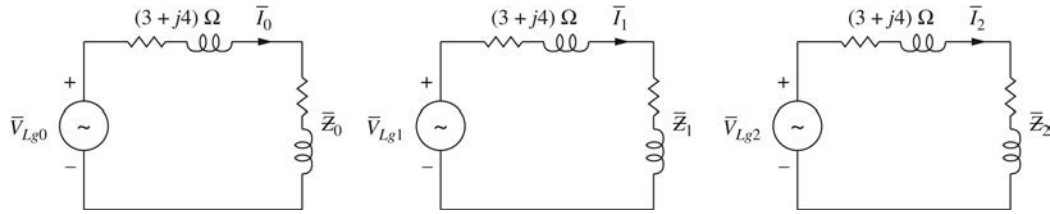

$$\bar{I}_0 = \frac{\bar{V}_{Lg0}}{3 + j4 + \bar{Z}_0} = \frac{5.039 \angle -57.65^\circ}{(3 + j4) + (12 + j16)} = \frac{5.039 \angle -57.65^\circ}{25 \angle 53.13^\circ} = 0.2016 \angle -110.78^\circ A$$

$$\bar{I}_1 = \frac{\bar{V}_{Lg1}}{3 + j4 + \bar{Z}_1} = \frac{272.4 \angle 6.59^\circ}{25 \angle 53.13^\circ} = 10.896 \angle -46.54^\circ A$$

$$\bar{I}_2 = \frac{\bar{V}_{Lg2}}{3 + j4 + \bar{Z}_2} = \frac{27.82 \angle -76.05^\circ}{25 \angle 53.13^\circ} = 1.1128 \angle -129.18^\circ A$$

$$\begin{aligned}
\begin{bmatrix} \bar{I}_a \\ \bar{I}_b \\ \bar{I}_c \end{bmatrix} &= \begin{bmatrix} 1 & 1 & 1 \\ 1 & a^2 & a \\ 1 & a & a^2 \end{bmatrix} \begin{bmatrix} 0.2016 \angle -110.78^\circ \\ 10.896 \angle -46.54^\circ \\ 1.1128 \angle -129.18^\circ \end{bmatrix} \\
&= \begin{bmatrix} 0.2016 \angle -110.78^\circ + 10.896 \angle -46.54^\circ + 1.1128 \angle -129.18^\circ \\ 0.2016 \angle -110.78^\circ + 10.896 \angle 193.46^\circ + 1.1128 \angle -9.18^\circ \\ 0.2016 \angle -110.78^\circ + 10.896 \angle 73.46^\circ + 1.1128 \angle 110.82^\circ \end{bmatrix} \\
&= \begin{bmatrix} 6.72 - j8.96 \\ -9.57 - j2.902 \\ 2.635 + j11.297 \end{bmatrix} = \begin{bmatrix} 11.2 \angle -53.13^\circ \\ 10 \angle -163.1^\circ \\ 11.6 \angle 76.87^\circ \end{bmatrix} \text{ A}
\end{aligned}$$

Also, since the source and load neutrals are connected with a zero-ohm neutral wire,

$$\begin{bmatrix} \bar{I}_a \\ \bar{I}_b \\ \bar{I}_c \end{bmatrix} = \begin{bmatrix} \bar{V}_{ag} / (3 + j4 + \bar{Z}_Y) \\ \bar{V}_{bg} / (3 + j4 + \bar{Z}_Y) \\ \bar{V}_{cg} / (3 + j4 + \bar{Z}_Y) \end{bmatrix} = \begin{bmatrix} 280 \angle 0^\circ / 25 \angle 53.13^\circ \\ 250 \angle -110^\circ / 25 \angle 53.13^\circ \\ 290 \angle 130^\circ / 25 \angle 53.13^\circ \end{bmatrix} = \begin{bmatrix} 11.2 \angle -53.13^\circ \\ 10 \angle -163.1^\circ \\ 11.6 \angle 76.87^\circ \end{bmatrix} \text{ A}$$

Which checks.

$$\begin{aligned}
\mathbf{8.27} \quad (\text{a}) \quad \text{KVL: } \bar{V}_{an} &= \bar{Z}_{aa} \bar{I}_a + \bar{Z}_{ab} \bar{I}_b + \bar{Z}_{ac} \bar{I}_c + \bar{Z}_{an} \bar{I}_n + \bar{V}_{a'n'} \\
&\quad - (\bar{Z}_{nn} \bar{I}_n + \bar{Z}_{an} \bar{I}_c + \bar{Z}_{an} \bar{I}_b + \bar{Z}_{an} \bar{I}_a)
\end{aligned}$$

Voltage drop across the line section is given by

$$\bar{V}_{an} - \bar{V}_{a'n'} = (\bar{Z}_{aa} - \bar{Z}_{an}) \bar{I}_a + (\bar{Z}_{ab} - \bar{Z}_{an}) (\bar{I}_b + \bar{I}_c) + (\bar{Z}_{an} - \bar{Z}_{nn}) \bar{I}_n$$

Similarly for phases b and c

$$\bar{V}_{bn} - \bar{V}_{b'n'} = (\bar{Z}_{aa} - \bar{Z}_{an}) \bar{I}_b + (\bar{Z}_{ab} - \bar{Z}_{an}) (\bar{I}_a + \bar{I}_c) + (\bar{Z}_{an} - \bar{Z}_{nn}) \bar{I}_n$$

$$\bar{V}_{cn} - \bar{V}_{c'n'} = (\bar{Z}_{aa} - \bar{Z}_{an}) \bar{I}_c + (\bar{Z}_{ab} - \bar{Z}_{an}) (\bar{I}_a + \bar{I}_b) + (\bar{Z}_{an} - \bar{Z}_{nn}) \bar{I}_n$$

$$\text{KCL: } \bar{I}_n = -(\bar{I}_a + \bar{I}_b + \bar{I}_c)$$

Upon substitution

$$\bar{V}_{an} - \bar{V}_{a'n'} = (\bar{Z}_{aa} + \bar{Z}_{nn} - 2\bar{Z}_{an}) \bar{I}_a + (\bar{Z}_{ab} + \bar{Z}_{nn} - 2\bar{Z}_{an}) \bar{I}_b + (\bar{Z}_{ab} + \bar{Z}_{nn} - 2\bar{Z}_{an}) \bar{I}_c$$

$$\bar{V}_{bn} - \bar{V}_{b'n'} = (\bar{Z}_{ab} + \bar{Z}_{nn} - 2\bar{Z}_{an}) \bar{I}_a + (\bar{Z}_{aa} + \bar{Z}_{nn} - 2\bar{Z}_{an}) \bar{I}_b + (\bar{Z}_{ab} + \bar{Z}_{nn} - 2\bar{Z}_{an}) \bar{I}_c$$

$$\bar{V}_{cn} - \bar{V}_{c'n'} = (\bar{Z}_{ab} + \bar{Z}_{nn} - 2\bar{Z}_{an}) \bar{I}_a + (\bar{Z}_{ab} + \bar{Z}_{nn} - 2\bar{Z}_{an}) \bar{I}_b + (\bar{Z}_{aa} + \bar{Z}_{nn} - 2\bar{Z}_{an}) \bar{I}_c$$

The presence of the neutral conductor changes the self- and mutual impedances of the phase conductors to the following effective values:

$$\bar{Z}_s \triangleq \bar{Z}_{aa} + \bar{Z}_{nn} - 2\bar{Z}_{an}; \quad \bar{Z}_m \triangleq \bar{Z}_{ab} + \bar{Z}_{nn} - 2\bar{Z}_{an}$$



Using the above definitions

$$\begin{bmatrix} \bar{V}_{aa'} \\ \bar{V}_{bb'} \\ \bar{V}_{cc'} \end{bmatrix} = \begin{bmatrix} \bar{V}_{an} - \bar{V}_{a'n'} \\ \bar{V}_{bn} - \bar{V}_{b'n'} \\ \bar{V}_{cn} - \bar{V}_{c'n'} \end{bmatrix} = \begin{bmatrix} \bar{Z}_s & \bar{Z}_m & \bar{Z}_m \\ \bar{Z}_m & \bar{Z}_s & \bar{Z}_m \\ \bar{Z}_m & \bar{Z}_m & \bar{Z}_s \end{bmatrix} \begin{bmatrix} \bar{I}_a \\ \bar{I}_b \\ \bar{I}_c \end{bmatrix}$$

Where the voltage drops across the phase conductors are denoted by  $\bar{V}_{aa'}, \bar{V}_{bb'}$ , and  $\bar{V}_{cc'}$ .

- (b) The a-b-c voltage drops and currents of the line section can be written in terms of their symmetrical components according to Eq. (8.1.9); with phase a as the reference phase, one gets

$$A \begin{bmatrix} \bar{V}_{aa'0} \\ \bar{V}_{aa'1} \\ \bar{V}_{aa'2} \end{bmatrix} = \left\{ \begin{bmatrix} \bar{Z}_s - \bar{Z}_m & \cdot & \cdot \\ \cdot & \bar{Z}_s - \bar{Z}_m & \cdot \\ \cdot & \cdot & \bar{Z}_s - \bar{Z}_m \end{bmatrix} + \begin{bmatrix} \bar{Z}_m & \bar{Z}_m & \bar{Z}_m \\ \bar{Z}_m & \bar{Z}_m & \bar{Z}_m \\ \bar{Z}_m & \bar{Z}_m & \bar{Z}_m \end{bmatrix} \right\} A \begin{bmatrix} \bar{I}_{a0} \\ \bar{I}_{a1} \\ \bar{I}_{a2} \end{bmatrix}$$

Multiplying across by  $A^{-1}$ ,

$$\begin{bmatrix} \bar{V}_{aa'0} \\ \bar{V}_{aa'1} \\ \bar{V}_{aa'2} \end{bmatrix} = A^{-1} \left\{ (\bar{Z}_s - \bar{Z}_m) \begin{bmatrix} 1 & \cdot & \cdot \\ \cdot & 1 & \cdot \\ \cdot & \cdot & 1 \end{bmatrix} + \bar{Z}_m \begin{bmatrix} 1 & 1 & 1 \\ 1 & 1 & 1 \\ 1 & 1 & 1 \end{bmatrix} \right\} A \begin{bmatrix} \bar{I}_{a0} \\ \bar{I}_{a1} \\ \bar{I}_{a2} \end{bmatrix}$$

or

$$\begin{bmatrix} \bar{V}_{aa'0} \\ \bar{V}_{aa'1} \\ \bar{V}_{aa'2} \end{bmatrix} = \begin{bmatrix} \bar{Z}_s - 2\bar{Z}_m & \cdot & \cdot \\ \cdot & \bar{Z}_s - \bar{Z}_m & \cdot \\ \cdot & \cdot & \bar{Z}_s - \bar{Z}_m \end{bmatrix} \begin{bmatrix} \bar{I}_{a0} \\ \bar{I}_{a1} \\ \bar{I}_{a2} \end{bmatrix}$$

Now define zero-, positive-, and negative-sequence impedances in terms of  $\bar{Z}_s$  and  $\bar{Z}_m$  as

$$\begin{aligned} \bar{Z}_0 &= \bar{Z}_s + 2\bar{Z}_m = \bar{Z}_{aa} + 2\bar{Z}_{ab} + 3\bar{Z}_{nn} - 6\bar{Z}_{an} \\ \bar{Z}_1 &= \bar{Z}_s - \bar{Z}_m = \bar{Z}_{aa} - \bar{Z}_{ab} \\ \bar{Z}_2 &= \bar{Z}_s - \bar{Z}_m = \bar{Z}_{aa} - \bar{Z}_{ab} \end{aligned}$$

Now, the sequence components of the voltage drops between the two ends of the line section can be written as three uncoupled equations:

$$\begin{aligned} \bar{V}_{aa'0} &= \bar{V}_{an0} - \bar{V}_{a'n'0} = \bar{Z}_0 \bar{I}_{a0} \\ \bar{V}_{aa'1} &= \bar{V}_{an1} - \bar{V}_{a'n'1} = \bar{Z}_1 \bar{I}_{a1} \\ \bar{V}_{aa'2} &= \bar{V}_{an2} - \bar{V}_{a'n'2} = \bar{Z}_2 \bar{I}_{a2} \end{aligned}$$

8.28 (a) The sequence impedances are given by

$$\bar{Z}_0 = \bar{Z}_{aa} + 2\bar{Z}_{ab} + 3\bar{Z}_{nn} - 6\bar{Z}_{an} = j60 + j40 + j240 - j180 = j160 \Omega$$

$$\bar{Z}_1 = \bar{Z}_2 = \bar{Z}_{aa} - \bar{Z}_{ab} = j60 - j20 = j40 \Omega$$

The sequence components of the voltage drops in the line are

$$\begin{aligned} \begin{bmatrix} \bar{V}_{aa'0} \\ \bar{V}_{aa'1} \\ \bar{V}_{aa'2} \end{bmatrix} &= A^{-1} \begin{bmatrix} \bar{V}_{an} - \bar{V}_{a'n'} \\ \bar{V}_{bn} - \bar{V}_{b'n'} \\ \bar{V}_{cn} - \bar{V}_{c'n'} \end{bmatrix} = A^{-1} \begin{bmatrix} (182.0 - 154.0) + j(70.0 - 28.0) \\ (72.24 - 44.24) - j(32.62 - 74.62) \\ -(170.24 - 198.24) + j(88.62 - 46.62) \end{bmatrix} \\ &= A^{-1} \begin{bmatrix} 28.0 + j42.0 \\ 28.0 + j42.0 \\ 28.0 + j42.0 \end{bmatrix} = \begin{bmatrix} 28.0 + j42.0 \\ 0 \\ 0 \end{bmatrix} \text{ kV} \end{aligned}$$

From PR. 8.22 result, it follows that

$$\bar{V}_{aa'0} = 28,000 + j42,000 = j160 \bar{I}_{a0}; \bar{V}_{aa'1} = 0 = j40 \bar{I}_{a1}; \bar{V}_{aa'2} = 0 = j40 \bar{I}_{a2}$$

From which the symmetrical components of the currents in phase a are

$$\bar{I}_{a0} = (262.5 - j175) \text{ A}; \bar{I}_{a1} = \bar{I}_{a2} = 0$$

The line currents are then given by

$$\bar{I}_a = \bar{I}_b = \bar{I}_c = (262.5 - j175) \text{ A}$$

(b) Without using symmetrical components:

The self- and mutual impedances [see solution of PR. 8.22(a)] are

$$\bar{Z}_s = \bar{Z}_{aa} + \bar{Z}_{nn} - 2\bar{Z}_{an} = j60 + j80 - j60 = j80 \Omega$$

$$\bar{Z}_m = \bar{Z}_{ab} + \bar{Z}_{nn} - 2\bar{Z}_{an} = j20 + j80 - j60 = j40 \Omega$$

So, line currents can be calculated as [see solution of PR. 8.22(a)]

$$\begin{aligned} \begin{bmatrix} \bar{V}_{aa'} \\ \bar{V}_{bb'} \\ \bar{V}_{cc'} \end{bmatrix} &= \begin{bmatrix} 28 + j42 \\ 28 + j42 \\ 28 + j42 \end{bmatrix} \times 10^3 = \begin{bmatrix} j80 & j40 & j40 \\ j40 & j80 & j40 \\ j40 & j40 & j80 \end{bmatrix} \begin{bmatrix} \bar{I}_a \\ \bar{I}_b \\ \bar{I}_c \end{bmatrix} \\ \begin{bmatrix} \bar{I}_a \\ \bar{I}_b \\ \bar{I}_c \end{bmatrix} &= \begin{bmatrix} j80 & j40 & j40 \\ j40 & j80 & j40 \\ j40 & j40 & j80 \end{bmatrix}^{-1} \begin{bmatrix} 28 + j42 \\ 28 + j42 \\ 28 + j42 \end{bmatrix} \times 10^3 \\ &= \begin{bmatrix} 262.5 - j175 \\ 262.5 - j175 \\ 262.5 - j175 \end{bmatrix} \text{ A} \end{aligned}$$

$$8.29 \quad \bar{Z}_1 = \bar{Z}_2 = j0.5 \times 200 = j100 \Omega$$

$$\bar{Z}_0 = j2 \times 200 = j400 \Omega$$

$$\bar{Y}_1 = \bar{Y}_2 = j3 \times 10^{-9} \times 200 \times 10^3 = j6 \times 10^{-4} \text{ S}$$

$$\bar{Y}_0 = j1 \times 10^{-9} \times 200 \times 10^3 = j2 \times 10^{-4} \text{ S}$$

Nominal- $\pi$  sequence circuits are shown below:

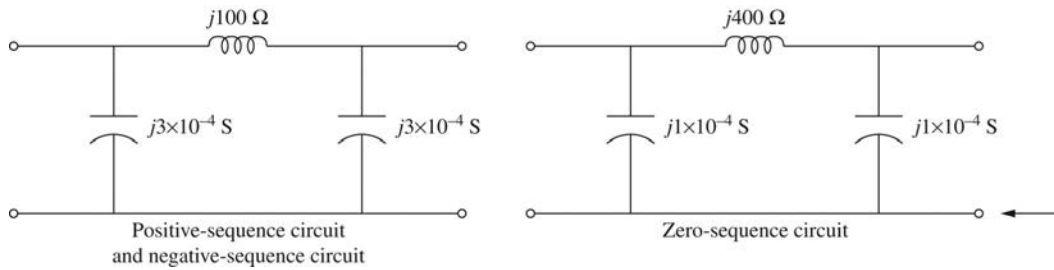

$$8.30 \quad (a) \quad \bar{I}_{AB} = \frac{\bar{V}_{AB}}{(18 + j10)} = \frac{480 \angle 0^\circ}{20.59 \angle 29.05^\circ} = 23.31 \angle -29.05^\circ \text{ A}$$

$$\bar{I}_{BC} = \frac{\bar{V}_{BC}}{(18 + j10)} = \frac{480 \angle 120^\circ}{20.59 \angle 29.05^\circ} = 23.31 \angle -149.05^\circ \text{ A}$$

$$(b) \quad \bar{I}_A = \bar{I}_{AB} = 23.31 \angle -29.05^\circ \text{ A}$$

$$\bar{I}_B = \bar{I}_{BC} - \bar{I}_{AB} = 23.31 \angle -149.05^\circ - 23.31 \angle -29.05^\circ$$

$$\bar{I}_B = -40.37 - j0.6693 = 40.38 \angle 180.95^\circ \text{ A}$$

$$\bar{I}_C = -\bar{I}_{BC} = 23.31 \angle 30.95^\circ \text{ A}$$

$$(c) \quad \begin{bmatrix} \bar{I}_{L0} \\ \bar{I}_{L1} \\ \bar{I}_{L2} \end{bmatrix} = \frac{1}{3} \begin{bmatrix} 1 & 1 & 1 \\ 1 & a & a^2 \\ 1 & a^2 & a \end{bmatrix} \begin{bmatrix} 23.31 \angle -29.05^\circ \\ 40.38 \angle 180.95^\circ \\ 23.31 \angle 30.95^\circ \end{bmatrix}$$

$$= \frac{1}{3} \begin{bmatrix} 23.31 \angle -29.05^\circ + 40.38 \angle 180.95^\circ + 23.31 \angle 30.95^\circ \\ 23.31 \angle -29.05^\circ + 40.38 \angle 300.95^\circ + 23.31 \angle 270.95^\circ \\ 23.31 \angle -29.05^\circ + 40.38 \angle 60.95^\circ + 23.31 \angle 150.95^\circ \end{bmatrix}$$

$$= \begin{bmatrix} 0 + j0 \\ 13.84 - j23.09 \\ 6.536 + j11.77 \end{bmatrix} = \begin{bmatrix} 0 \\ 26.92 \angle -59.06^\circ \\ 13.46 \angle 60.96^\circ \end{bmatrix} \text{ A}$$

8.31

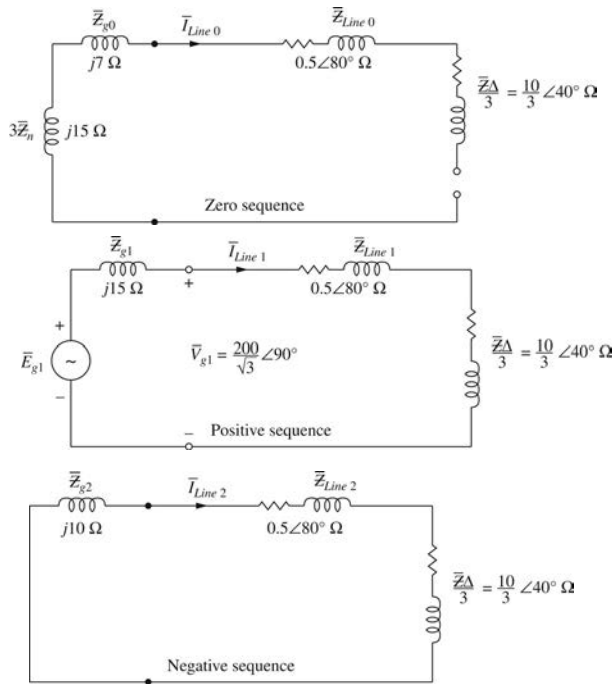

$$\bar{I}_{Line0} = \bar{I}_{Line2} = 0$$

$$\bar{I}_{Line1} = \frac{\bar{V}_{g1}}{\bar{Z}_{Line1} + \left(\frac{\bar{Z}_{\Delta}}{3}\right)} = \frac{\left(\frac{200}{\sqrt{3}}\right) \angle 90^{\circ}}{0.5 \angle 80^{\circ} + \left(\frac{10}{3}\right) \angle 40^{\circ}}$$

$$= \frac{115.47 \angle 90^{\circ}}{2.64 + j2.635} = \frac{115.47 \angle 90^{\circ}}{3.73 \angle 44.95^{\circ}} = 30.96 \angle 45.05^{\circ} \text{ A}$$

8.32

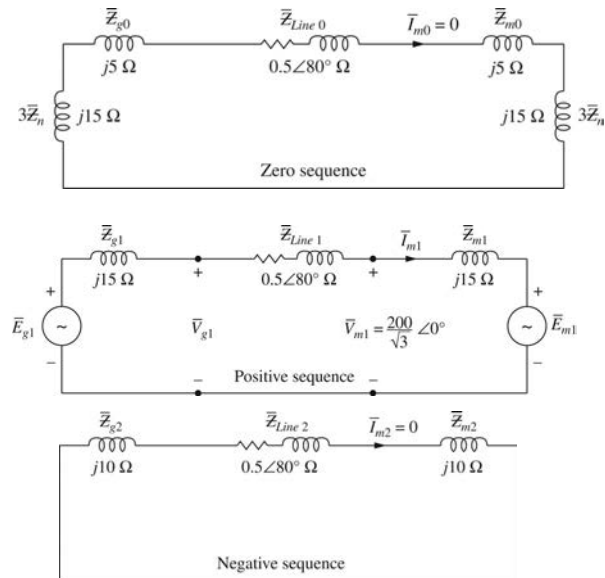

$$\begin{aligned}\bar{V}_{gan} &= \bar{V}_{g1} = \bar{V}_{m1} + \bar{Z}_{Line1} \bar{I}_{m1} \\ \bar{I}_{m1} &= \frac{5000 \angle \cos^{-1} 0.8}{200\sqrt{3}(0.8)} = 18.04 \angle 36.87^\circ \text{ A} \\ \bar{V}_{gan} &= \frac{200}{\sqrt{3}} \angle 0^\circ + (0.5 \angle 80^\circ)(18.04 \angle 36.87^\circ) \\ &= 115.47 + (-4.077 + j8.046) \\ &= 111.39 + j8.046 \\ &= 111.7 \angle 4.131^\circ \text{ V} \\ V_g &= \sqrt{3}(111.7) = 193.5 \text{ V (Line to Line)}\end{aligned}$$

**8.33** Converting the  $\Delta$  load to an equivalent  $Y$ , and then writing two loop equations:

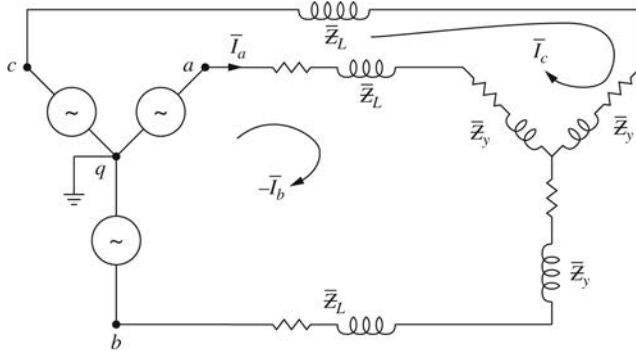

$$\begin{aligned}\begin{bmatrix} 2(\bar{Z}_L + \bar{Z}_Y) & | & -(\bar{Z}_L + \bar{Z}_Y) \\ -(\bar{Z}_L + \bar{Z}_Y) & | & 2(\bar{Z}_L + \bar{Z}_Y) \end{bmatrix} \begin{bmatrix} \bar{I}_c \\ -\bar{I}_b \end{bmatrix} &= \begin{bmatrix} \bar{V}_{cg} - \bar{V}_{ag} \\ \bar{V}_{ag} - \bar{V}_{bg} \end{bmatrix} \\ \begin{bmatrix} 21.46 \angle 43.78^\circ & | & -10.73 \angle 43.78^\circ \\ -10.73 \angle 43.78^\circ & | & 21.46 \angle 43.78^\circ \end{bmatrix} \begin{bmatrix} \bar{I}_c \\ -\bar{I}_b \end{bmatrix} &= \begin{bmatrix} 295 \angle 115^\circ - 277 \angle 0^\circ \\ 277 \angle 0^\circ - 260 \angle -120^\circ \end{bmatrix} \\ \begin{bmatrix} \bar{I}_c \\ -\bar{I}_b \end{bmatrix} &= \begin{bmatrix} 21.46 \angle 43.78^\circ & | & -10.73 \angle 43.78^\circ \\ -10.73 \angle 43.78^\circ & | & 21.46 \angle 43.78^\circ \end{bmatrix}^{-1} \begin{bmatrix} 482.5 \angle 146.35^\circ \\ 465.1 \angle 28.96^\circ \end{bmatrix} \\ \begin{bmatrix} \bar{I}_c \\ -\bar{I}_b \end{bmatrix} &= \begin{bmatrix} 0.06213 \angle -43.78^\circ & | & 0.03107 \angle -43.78^\circ \\ 0.03107 \angle -43.78^\circ & | & 0.06213 \angle -43.78^\circ \end{bmatrix} \begin{bmatrix} 482.5 \angle 146.35^\circ \\ 465.1 \angle 28.96^\circ \end{bmatrix} \\ \begin{bmatrix} \bar{I}_c \\ -\bar{I}_b \end{bmatrix} &= \begin{bmatrix} 29.98 \angle 102.57^\circ + 14.45 \angle -14.82^\circ \\ 14.99 \angle 102.57^\circ + 28.90 \angle -14.82^\circ \end{bmatrix} = \begin{bmatrix} 7.445 + j25.57 \\ 24.68 + j7.239 \end{bmatrix} \\ \begin{bmatrix} \bar{I}_c \\ -\bar{I}_b \end{bmatrix} &= \begin{bmatrix} 26.62 \angle 73.77^\circ \\ 25.71 \angle 16.34^\circ \end{bmatrix} \text{ A}\end{aligned}$$

Also,  $\bar{I}_a = -\bar{I}_b - \bar{I}_c$

$$\bar{I}_a = (24.68 + j7.239) - (7.445 + j25.57)$$

$$\bar{I}_a = 17.23 - j18.33 = 25.15 \angle -46.76^\circ$$

$$\begin{bmatrix} \bar{I}_a \\ \bar{I}_b \\ \bar{I}_c \end{bmatrix} = \begin{bmatrix} 25.15 \angle -46.76^\circ \\ 25.71 \angle 196.34^\circ \\ 26.62 \angle 73.77^\circ \end{bmatrix} A$$

which agrees with Ex. 8.6. The symmetrical components method is easier because it avoids the need to invert a matrix.

**8.34** The line-to-ground fault on phase *a* of the machine is shown below, along with the corresponding sequence networks:

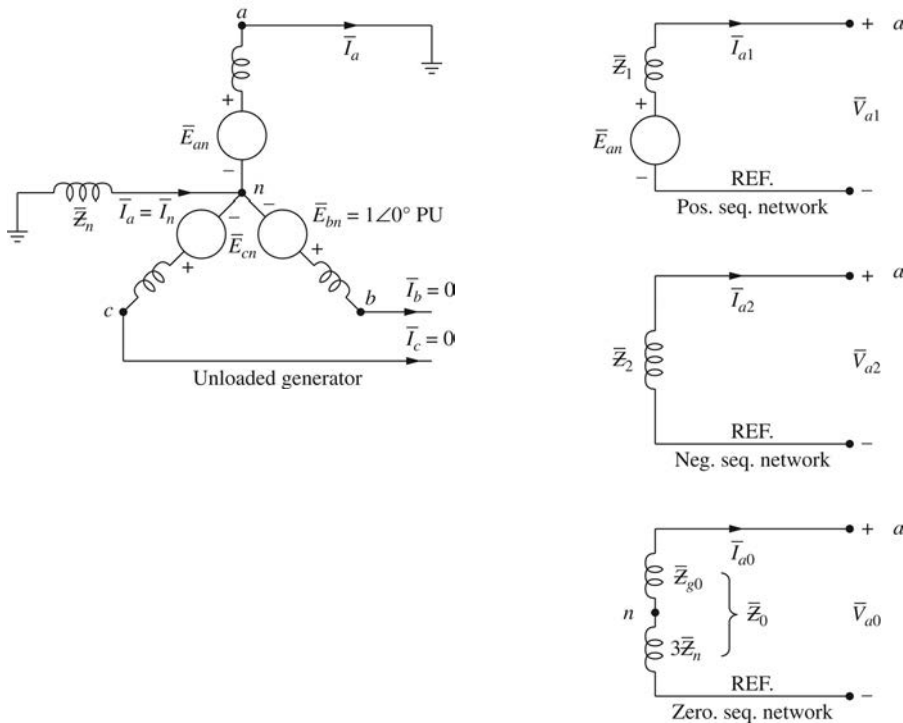

With the base voltage to neutral  $\frac{13.8}{\sqrt{3}}$  kV,

$$\bar{V}_a = 0; \quad \bar{V}_b = 1.013 \angle -102.25^\circ; \quad \bar{V}_c = 1.013 \angle 102.25^\circ \text{ pu.}$$

$$= (-0.215 - j0.99) \text{ pu} \quad = (-0.215 + j0.99) \text{ pu}$$

$$\text{with } \bar{Z}_{base} = \frac{(13.8)^2}{20} = 9.52 \Omega, \quad \bar{Z}_1 = \frac{j2.38}{9.52} = j0.25; \quad \bar{Z}_2 = \frac{j3.33}{9.52} = j0.35;$$

$$\bar{Z}_{g0} = \frac{j0.95}{9.52} = j0.1; \quad \bar{Z}_n = 0; \quad \bar{Z}_0 = j0.1 \text{ pu}$$

The symmetrical components of the voltages at the fault point are

$$\begin{bmatrix} \bar{V}_{a0} \\ \bar{V}_{a1} \\ \bar{V}_{a2} \end{bmatrix} = \frac{1}{3} \begin{bmatrix} 1 & 1 & 1 \\ 1 & a & a^2 \\ 1 & a^2 & a \end{bmatrix} \begin{bmatrix} 0 \\ -0.215 - j0.99 \\ -0.215 + j0.99 \end{bmatrix} = \begin{bmatrix} -0.143 + j0 \\ 0.643 + j0 \\ -0.500 + j0 \end{bmatrix} \text{ pu}$$

$$\bar{I}_{a0} = -\frac{\bar{V}_{a0}}{\bar{Z}_{g0}} = -\frac{(-0.143 + j0)}{j0.1} = -j1.43 \text{ pu}$$

$$\bar{I}_{a1} = \frac{\bar{E}_{an} - \bar{V}_{a1}}{\bar{Z}_1} = \frac{(1 + j0) - (0.643 + j0)}{j0.25} = -j1.43 \text{ pu}$$

$$\bar{I}_{a2} = -\frac{\bar{V}_{a2}}{\bar{Z}_2} = -\frac{(-0.5 + j0)}{j0.35} = -j1.43 \text{ pu}$$

$$\therefore \text{Fault current into the ground } \bar{I}_a = \bar{I}_{a0} + \bar{I}_{a1} + \bar{I}_{a2} = 3\bar{I}_{a0} = -j4.29 \text{ pu}$$

With base current  $\frac{20,000}{\sqrt{3} \times 13.8} = 837 \text{ A}$ , the subtransient current in line  $a$  is

$$I_a = 4.29 \times 837 = 3590 \text{ A}$$

Line-to-line voltages during the fault are: (on base voltage to neutral)

$$\bar{V}_{ab} = \bar{V}_a - \bar{V}_b = 0.215 + j0.99 = 1.01 \angle 77.7^\circ \text{ pu} = 8.05 \angle 77.7^\circ \text{ kV}$$

$$\bar{V}_{bc} = \bar{V}_b - \bar{V}_c = 0 - j1.98 = 1.98 \angle 270^\circ \text{ pu} = 15.78 \angle 270^\circ \text{ kV}$$

$$\bar{V}_{ca} = \bar{V}_c - \bar{V}_a = -0.215 + j0.99 = 1.01 \angle 102.3^\circ \text{ pu} = 8.05 \angle 102.3^\circ \text{ kV}$$

Phasor diagrams of line voltages before and after the fault are shown below:

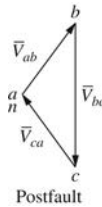
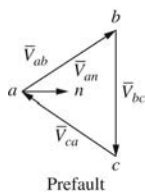

$$\bar{V}_{ab} = 13.8 \angle 30^\circ \text{ kV}$$

$$\bar{V}_{bc} = 13.8 \angle 270^\circ \text{ kV}$$

$$\bar{V}_{ca} = 13.8 \angle 150^\circ \text{ kV}$$

(Balanced)

$$\bar{V}_{ab} = 8.05 \angle 77.7^\circ \text{ kV}$$

$$\bar{V}_{bc} = 15.78 \angle 270^\circ \text{ kV}$$

$$\bar{V}_{ca} = 8.05 \angle 102.3^\circ \text{ kV}$$

(Unbalanced)

### 8.35 Base MVA = 100

$$G_1 : X = 0.1 \times \frac{100}{20} = 0.5; G_2 : X = 0.15 \times \frac{100}{40} = 0.375; G_3 : X = 0.15 \times \frac{100}{40} = 0.375$$

$$\text{Reactors: } X_1 = 0.05 \times \frac{100}{20} = 0.25; X_2 = 0.04 \times \frac{100}{16} = 0.25 \text{ pu.}$$

Per-phase reactance diagram is shown below: (Excluding the source)

[in pu]

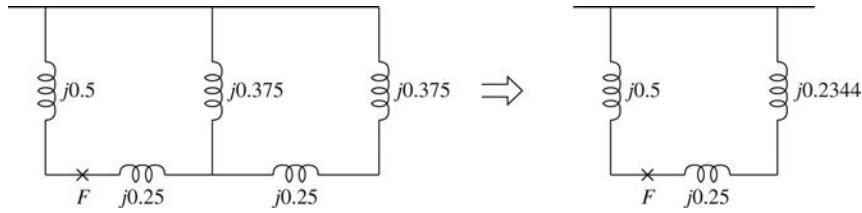

$[j0.5 \parallel j(0.25 + 0.2344)]$  with respect to  $f = j 0.246$

$$\therefore \text{Fault MVA} = \frac{100}{0.246} = 406.5 \text{ MVA} \leftarrow$$

$$\begin{aligned} \text{Fault Current} &= \frac{406.5 \times 10^6}{\sqrt{3} \times 13.2 \times 10^3} = 17,780 \text{ A} \\ &= 17.78 \text{ kA} \end{aligned}$$

**8.36** Line-to-ground fault: Let  $V_a = 0$ ;  $I_b = I_c = 0$   $\leftarrow$

$$\text{Then } \bar{I}_{a0} = \frac{1}{3}(\bar{I}_a + \bar{I}_b + \bar{I}_c) = \frac{1}{3}\bar{I}_a$$

$$\bar{I}_{a1} = \frac{1}{3}(\bar{I}_a + a\bar{I}_b + a^2\bar{I}_c) = \frac{1}{3}\bar{I}_a$$

$$\bar{I}_{a2} = \frac{1}{3}(\bar{I}_a + a^2\bar{I}_b + a\bar{I}_c) = \frac{1}{3}\bar{I}_a$$

$$\text{so that } \bar{I}_{a0} = \bar{I}_{a1} = \bar{I}_{a2} = \frac{1}{3}\bar{I}_a; \bar{V}_{a0} + \bar{V}_{a1} + \bar{V}_{a2} = 0 \leftarrow$$

Sequence network interconnection is shown below:

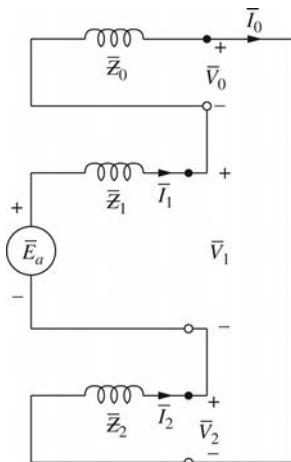

$$\begin{aligned} \bar{I}_0 = \bar{I}_1 = \bar{I}_2 &= \frac{\bar{E}_a}{\bar{Z}_0 + \bar{Z}_1 + \bar{Z}_2} \\ \bar{V}_0 + \bar{V}_1 + \bar{V}_2 &= 0 \quad \leftarrow \\ \bar{I}_a &= \frac{3\bar{E}_a}{\bar{Z}_0 + \bar{Z}_1 + \bar{Z}_2} \end{aligned}$$



8.37 (a) Short circuit between phases  $b$  and  $c$ :  $\bar{I}_b + \bar{I}_c = 0$ ;  $\bar{I}_a = 0$  (Open Line);  $\bar{V}_b = \bar{V}_c$

then  $\bar{I}_{a0} = 0$ ;

$$\begin{aligned}\bar{I}_{a1} &= \frac{1}{3}(0 + a\bar{I}_b + a^2\bar{I}_c) = \frac{1}{3}(a\bar{I}_b - a^2\bar{I}_b) \\ &= \frac{1}{3}(a - a^2)\bar{I}_b\end{aligned}$$

$$\bar{I}_{a2} = \frac{1}{3}(0 + a^2\bar{I}_b + a\bar{I}_c) = \frac{1}{3}(a^2\bar{I}_b - a\bar{I}_b) = \frac{1}{3}(a^2 - a)\bar{I}_b$$

so that  $\bar{I}_{a1} = -\bar{I}_{a2}$

From  $\bar{V}_b = \bar{V}_c$ , one gets  $\bar{V}_{a0} + a^2\bar{V}_{a1} + a\bar{V}_{a2} = \bar{V}_{a0} + a\bar{V}_{a1} + a^2\bar{V}_{a2}$

so that  $\bar{V}_{a1} = \bar{V}_{a2}$

Sequence network interconnection is shown below:

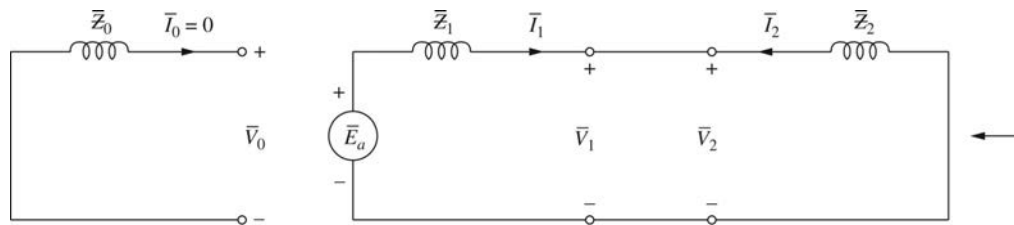

(b) Double line-to-ground fault:

Fault conditions in phase domain are represented by  $\bar{I}_a = 0$ ;  $\bar{V}_b = \bar{V}_c = 0$

Sequence components:  $\bar{V}_{a0} = \bar{V}_{a1} = \bar{V}_{a2} = \frac{1}{3}\bar{V}_a$

$$\bar{I}_{a0} + \bar{I}_{a1} + \bar{I}_{a2} = 0$$

Sequence network interconnection is shown below:

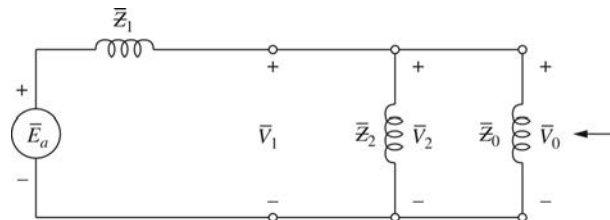

8.38 (a)

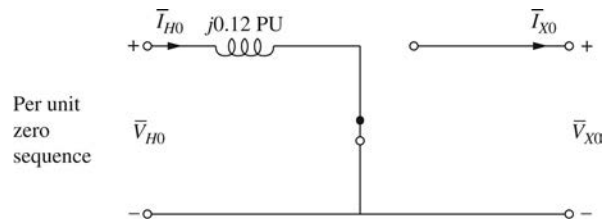

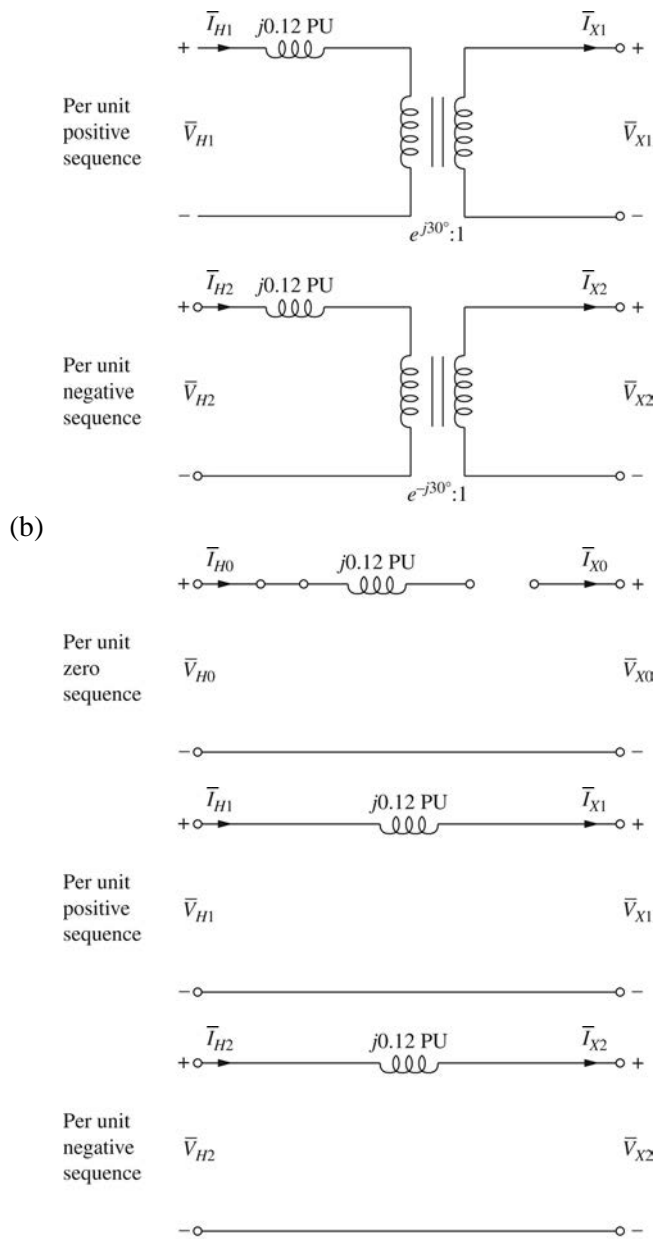

### 8.39

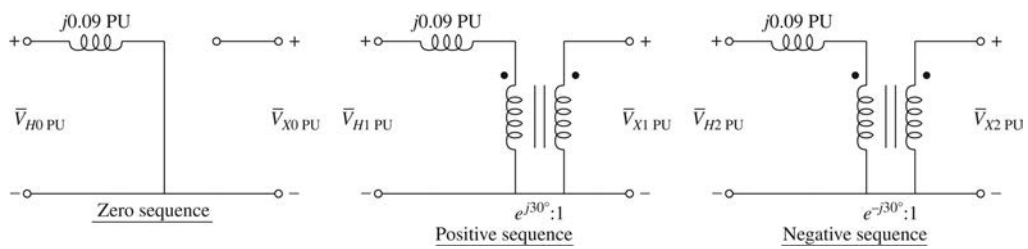

$$8.40 \quad X_{pu\ new} = (0.09) \left( \frac{345}{360} \right)^2 \left( \frac{100}{300} \right) = 0.02755 \text{ per unit}$$

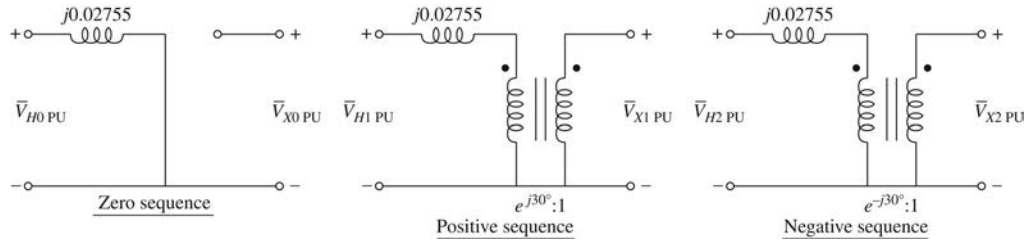

8.41

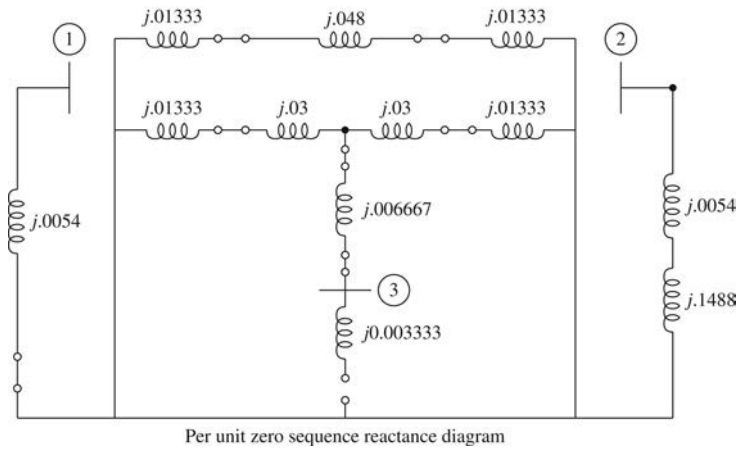

$$X_{g1-0} = (0.05) \left( \frac{18}{20} \right)^2 \left( \frac{100}{750} \right) = 0.0054 = X_{g2-0}$$

$$X_{m3-0} = (0.05) \left( \frac{100}{1500} \right) = 0.003333$$

$$X_{n2} = (0.06) \left( \frac{18}{20} \right)^2 = 0.0486 \quad 3X_{n2} = 0.1458$$

$$8.42 \quad \bar{V}_{A1} = 1 \angle 45^\circ + 30^\circ = 1 \angle 75^\circ = 0.2588 + j0.9659$$

$$\bar{V}_{A2} = 0.25 \angle 250 - 30^\circ = 0.25 \angle 220^\circ = -0.1915 - j0.1607$$

$$\bar{V}_A = \bar{V}_{A1} + \bar{V}_{A2} = 0.0673 + j0.8052 = 0.808 \angle 85.2^\circ$$

$$\bar{V}_{B1} = a^2 \bar{V}_{A1} = 1 \angle 315^\circ = 1 \angle -45^\circ = 0.7071 - j0.7071$$

$$\bar{V}_{B2} = a \bar{V}_{A2} = 0.25 \angle 340^\circ = 0.25 \angle -20^\circ = 0.2349 - j0.0855$$

$$\bar{V}_B = \bar{V}_{B1} + \bar{V}_{B2} = 0.942 - j0.7926 = 1.02 \angle -40.1^\circ$$

$$\bar{V}_{C1} = a \bar{V}_{A1} = 1 \angle 195^\circ = -0.9659 - j0.2588$$

$$\bar{V}_{C2} = a^2 \bar{V}_{A2} = 0.25 \angle 100^\circ = -0.0434 + j0.2462$$

$$\bar{V}_C = \bar{V}_{C1} + \bar{V}_{C2} = -1.0093 - j0.0126 = 1.009 \angle 180.7^\circ$$

Line-to-line voltages are given by: [in pu on line-neutral voltage base]

$$\begin{aligned} \bar{V}_{AB} &= \bar{V}_A - \bar{V}_B = -0.8747 + j1.5978 \\ &= 1.82 \angle 118.7^\circ \leftarrow \\ \bar{V}_{BC} &= \bar{V}_B - \bar{V}_C = 1.9513 - j0.78 \\ &= 2.1 \angle -21.8^\circ \leftarrow \\ \bar{V}_{CA} &= \bar{V}_C - \bar{V}_A = -1.0766 - j0.8178 \\ &= 1.352 \angle 217.2^\circ \leftarrow \end{aligned} \quad \left\{ \begin{array}{l} \text{Note: Divide by } \sqrt{3} \\ \text{if the base is} \\ \text{line-to-line voltage} \end{array} \right.$$

Load impedance in each phase is  $1 \angle 0^\circ$  pu.

$$\therefore \bar{I}_{a1} = \bar{V}_{a1} \text{ in pu; } \bar{I}_{a2} = \bar{V}_{a2} \text{ in pu}$$

Thus  $\bar{I}_A = \bar{V}_A$  in pu

$$\left. \begin{aligned} \bar{I}_A &= 0.808 \angle 85.2^\circ \text{ pu} \\ \bar{I}_B &= 1.02 \angle -40.1^\circ \text{ pu} \\ \bar{I}_C &= 1.009 \angle 180.7^\circ \text{ pu} \end{aligned} \right\} \leftarrow$$

### 8.43 (a)

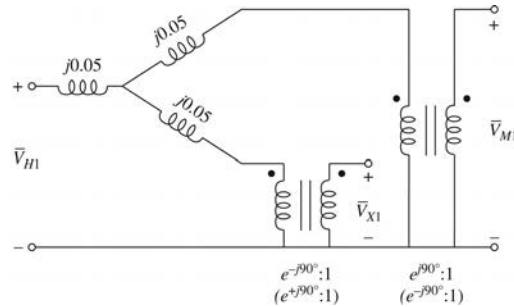
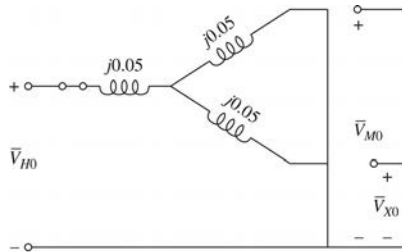

Per Unit Zero Sequence

$$\begin{aligned} X_1 = X_2 = X_3 &= \frac{1}{2}(0.1 + 0.1 - 0.1) \\ &= 0.05 \text{ per unit} \end{aligned}$$

$$\bar{e}^{j90^\circ} : i \quad e^{j90^\circ} : i$$

$$(e^{+j90^\circ} : i) \quad (\bar{e}^{j90^\circ} : i)$$

Per Unit Positive Sequence

(Per Unit Negative Sequence)

### (b)

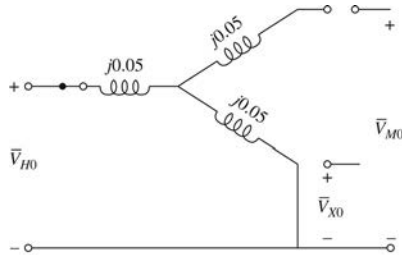

Per Unit Zero Sequence

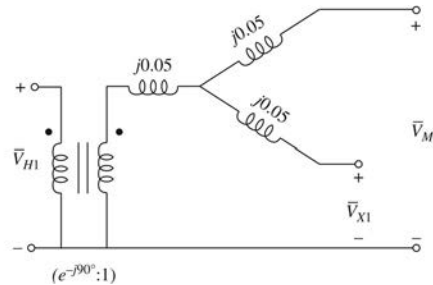

Per Unit Positive Sequence

(Per Unit Negative Sequence)

(c)

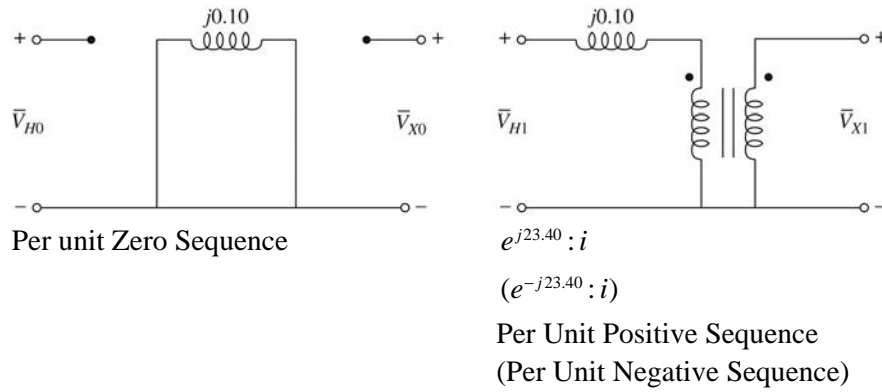

8.44

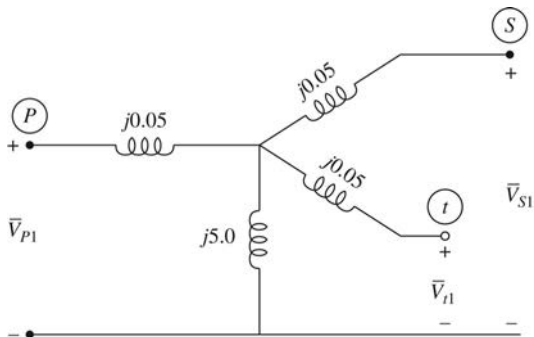
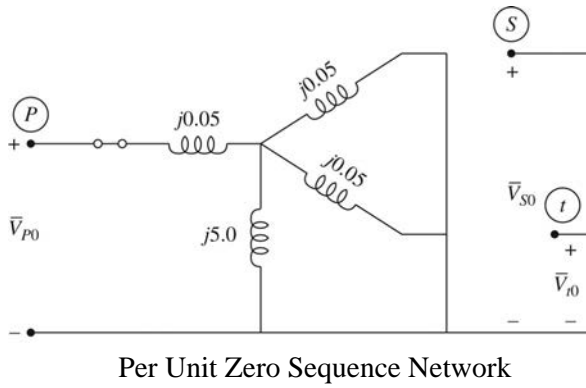

p-primary  
s-secondary  
t-tertiary

$$\begin{aligned}
8.45 \quad \bar{S}_{3\phi} &= \bar{V}_{an} \bar{I}_a^* + \bar{V}_{bn} \bar{I}_b^* + \bar{V}_{cn} \bar{I}_c^* \\
&= (280 \angle 0^\circ)(14 \angle 53.13^\circ) + (250 \angle -110^\circ)(12.5 \angle 163.1^\circ) \\
&\quad + (290 \angle 130^\circ)(14.5 \angle -76.87^\circ) \\
&= 3920 \angle 53.13^\circ + 3125 \angle 53.1^\circ + 4205 \angle 53.13^\circ \\
&= 6751 + j8999 \\
\left. \begin{aligned} \bar{P}_{3\phi} &= \text{Re} \bar{S}_{3\phi} = 6751 \text{ W} \\ \bar{Q}_{3\phi} &= \text{Im} \bar{S}_{3\phi} = 8999 \text{ vars} \end{aligned} \right\} \text{delivered to the load.}
\end{aligned}$$

8.46 (a)

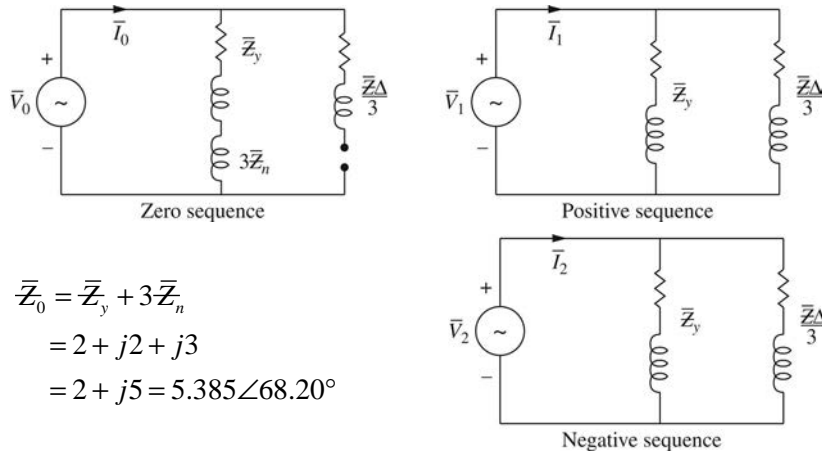

$$\begin{aligned}
\bar{Z}_0 &= \bar{Z}_y + 3\bar{Z}_n \\
&= 2 + j2 + j3 \\
&= 2 + j5 = 5.385 \angle 68.20^\circ
\end{aligned}$$

$$(b) \quad \bar{I}_0 = \frac{\bar{V}_0}{\bar{Z}_0} = \frac{10 \angle 60^\circ}{5.385 \angle 68.20^\circ}$$

$$I_0 = 1.857 \angle -8.199^\circ \text{ A}$$

$$\bar{Z}_1 = \bar{Z}_y \parallel \frac{\bar{Z}_\Delta}{3} = (2 + j2) \parallel (2 + j2) = 1 + j = \sqrt{2} \angle 45^\circ \Omega$$

$$\bar{I}_1 = \frac{\bar{V}_1}{\bar{Z}_1} = \frac{100 \angle 0^\circ}{\sqrt{2} \angle 45^\circ} = 70.71 \angle -45^\circ \text{ A}$$

$$\bar{Z}_2 = \bar{Z}_1 = \sqrt{2} \angle 45^\circ \Omega$$

$$\bar{I}_2 = \frac{\bar{V}_2}{\bar{Z}_2} = \frac{15 \angle 200^\circ}{\sqrt{2} \angle 45^\circ} = 10.61 \angle 155^\circ \text{ A}$$

$$\bar{S}_0 = \bar{V}_0 \bar{I}_0^* = (10 \angle 60^\circ)(1.857 \angle 8.199^\circ) = 6.897 + j17.24$$

$$\bar{S}_0 = 18.57 \angle 68.199^\circ$$

$$\bar{S}_1 = \bar{V}_1 \bar{I}_1^* = (100 \angle 0^\circ)(70.71 \angle 45^\circ) = 5000 + j5000$$

$$\bar{S}_1 = 7071 \angle 45^\circ$$

$$\bar{S}_2 = \bar{V}_2 \bar{I}_2^* = (15 \angle 200^\circ)(10.61 \angle -155^\circ) = 112.5 + j112.5$$

$$\bar{S}_2 = 159. \angle 45^\circ$$

$$(c) \bar{S}_{3\phi} = 3(\bar{S}_0 + \bar{S}_1 + \bar{S}_2) = 3(5119 + j5129)$$

$$\bar{S}_{3\phi} = 15,358. + j15,389.$$

$$\bar{S}_{3\phi} = 21.74 \times 10^3 \angle 45.06^\circ \text{ VA}$$

$$8.47 \quad \bar{S}_{3\phi} = \bar{V}_{a0} \bar{I}_{a0}^* + \bar{V}_{a1} \bar{I}_{a1}^* + \bar{V}_{a2} \bar{I}_{a2}^*$$

Substituting values of voltages and currents from the solution of PR.8.8,

$$\bar{S}_{3\phi} = 0 + (0.9857 \angle 43.6^\circ)(0.9857 \angle -43.6^\circ) + (0.2346 \angle 250.3^\circ)(0.2346 \angle -250.3^\circ)$$

$$= (0.9857)^2 + (0.2346)^2$$

$$= 1.02664 \text{ pu}$$

With the three-phase 500-kVA base,

$$S_{3\phi} = 513.32 \text{ kW}$$

To compute directly:

The Equivalent  $\Delta$ -Connected resistors are

$$R_\Delta = 3R_Y = 3 \times 10.58 = 31.74 \Omega$$

From the given line-to-line voltages

$$\begin{aligned} S_{3\phi} &= \frac{|V_{ab}|^2}{R_\Delta} + \frac{|V_{bc}|^2}{R_\Delta} + \frac{|V_{ca}|^2}{R_\Delta} \\ &= \frac{(1840)^2 + (2760)^2 + (2300)^2}{31.74} \\ &= 513.33 \text{ kW} \end{aligned}$$

8.48 The complex power delivered to the load in terms of symmetrical components:

$$\bar{S}_{3\phi} = 3(\bar{V}_{a0} \bar{I}_{a0}^* + \bar{V}_{a1} \bar{I}_{a1}^* + \bar{V}_{a2} \bar{I}_{a2}^*)$$

Substituting values from the solution of PR. 8.20,

$$\begin{aligned} \bar{S}_{3\phi} &= 3 \left[ 47.7739 \angle 57.6268^\circ (1.4484 \angle 18.3369^\circ) + 112.7841 \angle -0.0331^\circ (5.2359 \angle 68.2317^\circ) \right. \\ &\quad \left. + 61.6231 \angle 45.8825^\circ (2.8608 \angle 22.3161^\circ) \right] \end{aligned}$$

$$= 904.71 + j2337.3 \text{ VA}$$

The complex power delivered to the load by summing up the power in each phase:

$$\bar{S}_{3\phi} = \bar{V}_a \bar{I}_a^* + \bar{V}_b \bar{I}_b^* + \bar{V}_c \bar{I}_c^*; \text{ with values from PR. 8.20 solution,}$$

$$= 200 \angle 25^\circ (8.7507 \angle 47.0439^\circ) + 100 \angle -155^\circ (5.2292 \angle -143.2431^\circ)$$

$$+ 80 \angle 100^\circ (3.028 \angle -39.0673^\circ)$$

$$= 904.71 + j2337.3 \text{ VA}$$

**8.49** From PR. 8.6(a) solution:

$$\bar{V}_a = 116\angle 9.9^\circ \text{ V}; \bar{V}_b = 41.3\angle -76^\circ \text{ V}; \bar{V}_c = 96.1\angle 168^\circ \text{ V}$$

$$\text{From PR.8.5, } \bar{I}_a = 12\angle 0^\circ \text{ A}; \bar{I}_b = 6\angle -90^\circ \text{ A}; \bar{I}_c = 8\angle 150^\circ \text{ A}$$

**(a)** In terms of phase values

$$\begin{aligned} \bar{S} &= \bar{V}_a \bar{I}_a^* + \bar{V}_b \bar{I}_b^* + \bar{V}_c \bar{I}_c^* \\ &= 116\angle 9.9^\circ (12\angle 0^\circ) + 41.3\angle -76^\circ (6\angle 90^\circ) + 96.1\angle 168^\circ (8\angle -150^\circ) \\ &= (2339.4 + j537.4) \text{ VA} \quad \leftarrow \end{aligned}$$

**(b)** In terms of symmetrical components:

$$\bar{V}_0 = 10\angle 0^\circ \text{ V}; \bar{V}_1 = 80\angle 30^\circ \text{ V}; \bar{V}_2 = 40\angle -30^\circ \text{ V} \quad \text{From PR. 8.6(a)}$$

$$\bar{I}_0 = 1.82\angle -21.5^\circ \text{ A}; \bar{I}_1 = 8.37\angle 16.2^\circ \text{ A}; \bar{I}_2 = 2.81\angle -36.3^\circ \quad \text{From PR. 8.5 Soln.}$$

$$\begin{aligned} \therefore \bar{S} &= 3(\bar{V}_0 \bar{I}_0^* + \bar{V}_1 \bar{I}_1^* + \bar{V}_2 \bar{I}_2^*) \\ &= 3[10\angle 0^\circ (1.82\angle 21.5^\circ) + 80\angle 30^\circ (8.37\angle -16.2^\circ) + 40\angle -30^\circ (2.81\angle 36.3^\circ)] \\ &= 3(779.8 + j179.2) \\ &= (2339.4 + j537.4) \text{ VA} \quad \leftarrow \end{aligned}$$





# Chapter 9

## Unsymmetrical Faults

### ANSWERS TO MULTIPLE-CHOICE TYPE QUESTIONS

- 9.1 a
- 9.2 a
- 9.3 Positive
- 9.4 Single line-to-ground, line-to-line, double line-to-ground, balanced three-phase faults
- 9.5  $\bar{I}_0$  and  $\bar{I}_2$ ; zero; zero
- 9.6 In series;  $3Z_F$ ; all equal
- 9.7 In parallel; 1; zero
- 9.8 In parallel;  $3Z_F$
- 9.9 a

## 9.1 Calculation of per unit reactances

### **Synchronous generators:**

$$G1 \quad X_1 = X_d'' = 0.18 \quad X_2 = X_d'' = 0.18 \quad X_0 = 0.07$$

$$G2 \quad X_1 = X_d'' = 0.20 \quad X_2 = X_d'' = 0.20 \quad X_0 = 0.10$$

$$G3 \quad X_1 = X_d'' = 0.15 \left( \frac{13.8}{15} \right)^2 \left( \frac{1000}{500} \right) \quad X_0 = 0.05 \left( \frac{13.8}{15} \right)^2 \left( \frac{1000}{500} \right)$$

$$= 0.2539 \quad = 0.08464$$

$$X_2 = X_d'' = 0.2539 \quad 3X_n = 3X_0 = 0.2539$$

$$G4 \quad X_1 = X_d'' = 0.30 \left( \frac{13.8}{15} \right)^2 \left( \frac{1000}{750} \right)$$

$$= 0.3386$$

$$X_2 = 0.40 \left( \frac{13.8}{15} \right)^2 \left( \frac{1000}{750} \right) \quad X_0 = 0.10 \left( \frac{13.8}{15} \right)^2 \left( \frac{1000}{750} \right)$$

$$= 0.4514 \quad = 0.1129$$

### **Transformers:**

$$X_{T1} = 0.10 \quad X_{T2} = 0.10 \quad X_{T3} = 0.12 \left( \frac{1000}{500} \right)$$

$$X_{T4} = 0.11 \left( \frac{1000}{750} \right) = 0.1467 \quad = 0.24$$

### **Transmission Lines:**

$$Z_{base H} = \frac{(765)^2}{1000} = 585.23 \Omega$$

Positive/Negative Sequence

$$X_{12} = \frac{50}{585.23} = 0.08544$$

$$X_{13} = X_{23} = \frac{40}{585.23}$$

$$= 0.06835$$

Zero Sequence

$$X_{12} = \frac{150}{585.23}$$

$$= 0.2563$$

$$X_{13} = X_{23} = \frac{100}{585.23}$$

$$= 0.1709$$

9.2  $n = 1$  (Bus 1 = Fault Bus)

**Thevenin equivalents as viewed from Bus 1:**

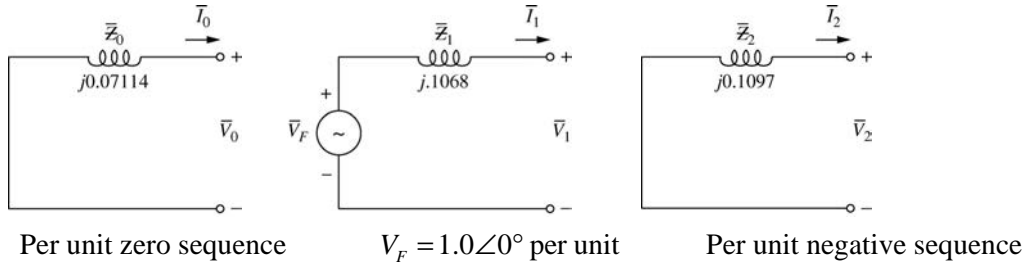

**Zero sequence Thevenin Equivalent:**

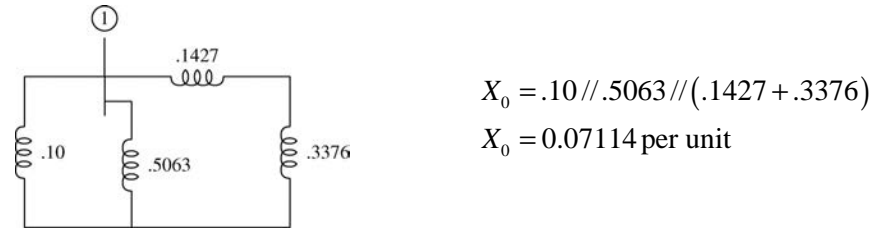
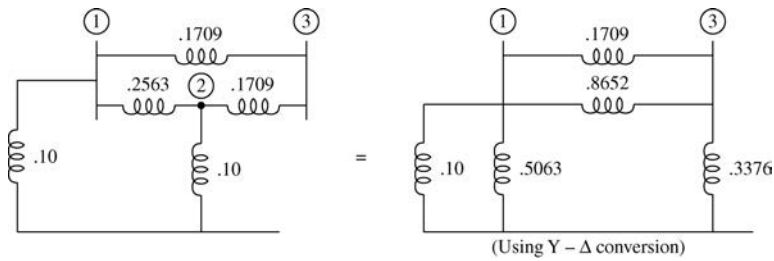

**Negative Sequence Thevenin Equivalent:**

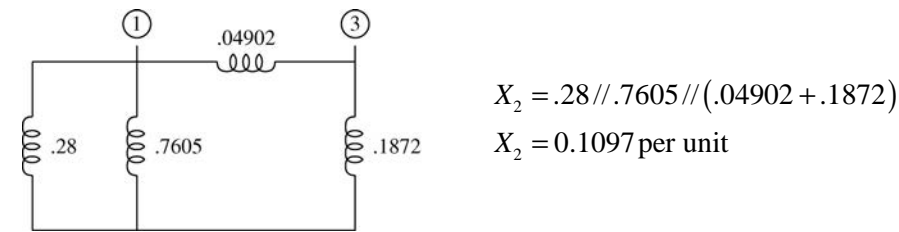
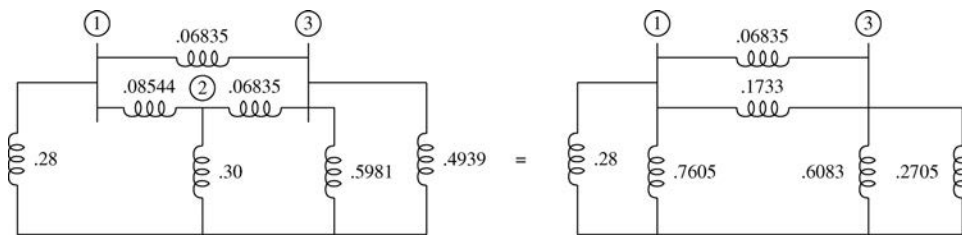

Similarly,  $X_1 = .28 // .7605 // (.04902 + .1745) = 0.1068$

9.3 Three-phase fault at bus 1.

**Using the positive-sequence Thevenin equivalent from Problem 9.2:**

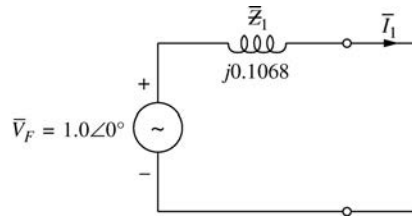

$$I_{base H} = \frac{S_{base 3\phi}}{\sqrt{3} V_{base H}} = \frac{1000}{\sqrt{3}(765)} = 0.7547 \text{ kA}$$

$$\bar{I}_1 = \frac{\bar{V}_F}{\bar{Z}_1} = \frac{1.0\angle 0^\circ}{j0.1068} = -j9.363 \text{ per unit}$$

$$\bar{I}_0 = \bar{I}_2 = 0$$

$$\begin{bmatrix} \bar{I}_A'' \\ \bar{I}_B'' \\ \bar{I}_C'' \end{bmatrix} = \begin{bmatrix} 1 & 1 & 1 \\ 1 & a^2 & a \\ 1 & a & a^2 \end{bmatrix} \begin{bmatrix} 0 \\ -j9.363 \\ 0 \end{bmatrix} = \begin{bmatrix} 9.363\angle -90^\circ \\ 9.363\angle 150^\circ \\ 9.363\angle 30^\circ \end{bmatrix} \text{ per unit}$$

$$\begin{bmatrix} \bar{I}_A'' \\ \bar{I}_B'' \\ \bar{I}_C'' \end{bmatrix} = \begin{bmatrix} 9.363\angle -90^\circ \\ 9.363\angle 150^\circ \\ 9.363\angle 30^\circ \end{bmatrix} \times 0.7547 = \begin{bmatrix} 7.067\angle -90^\circ \\ 7.067\angle 150^\circ \\ 7.067\angle 30^\circ \end{bmatrix} \text{ kA}$$

9.4 (a)

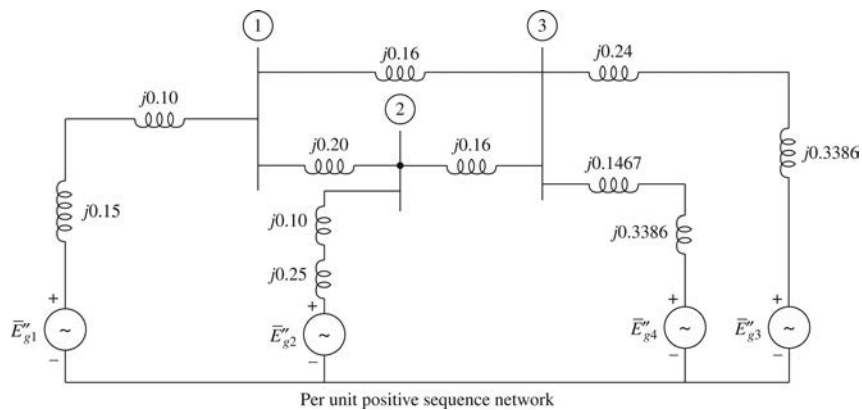
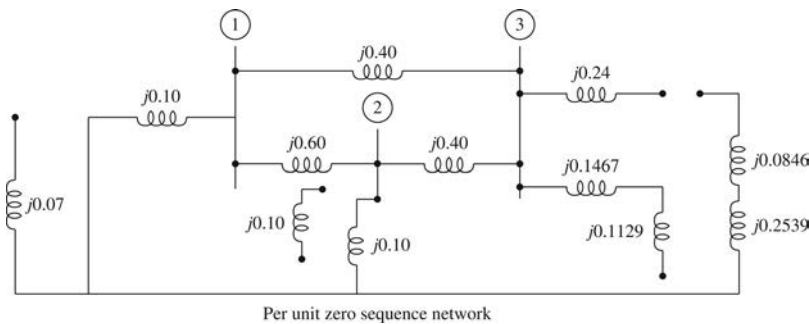

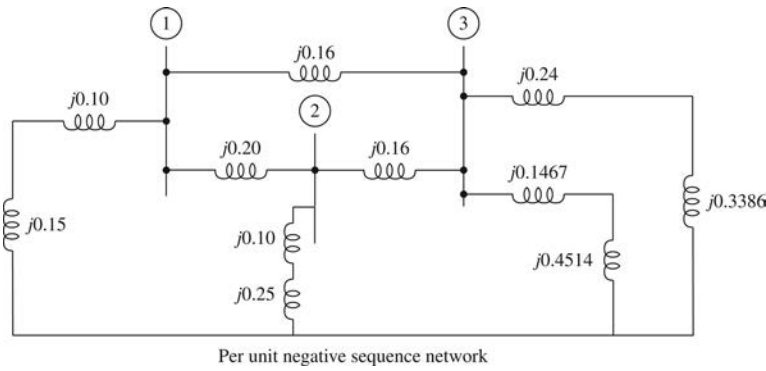

(b)  $n = 1$  (Bus 1 = fault bus)

Thevenin equivalents as viewed from bus 1:

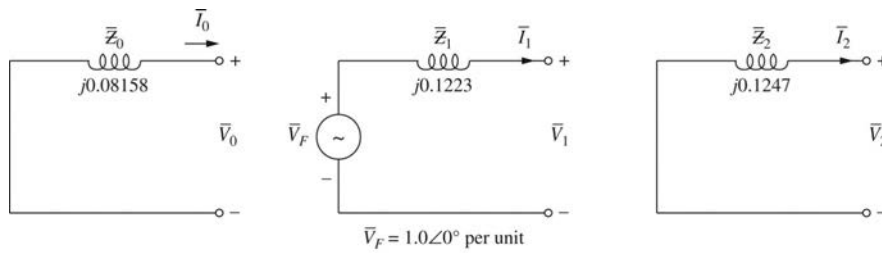

Zero sequence thevenin equivalent:

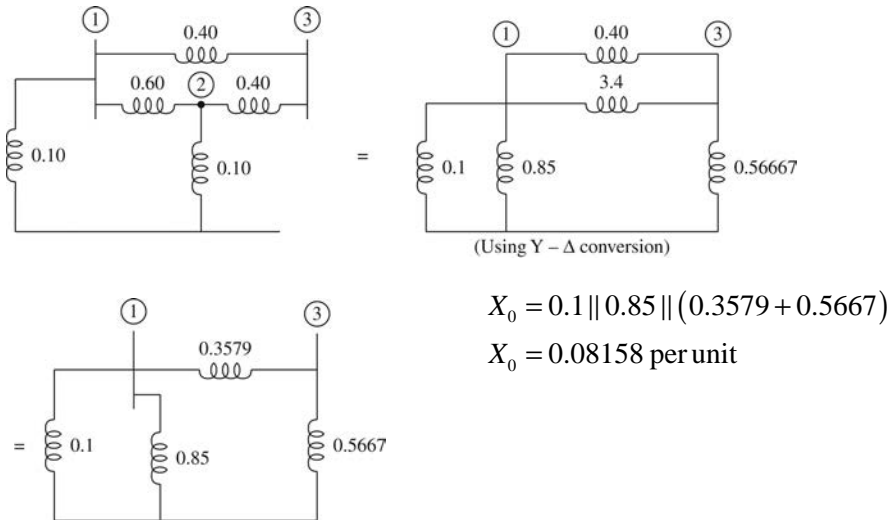

Negative sequence thevenin equivalent:

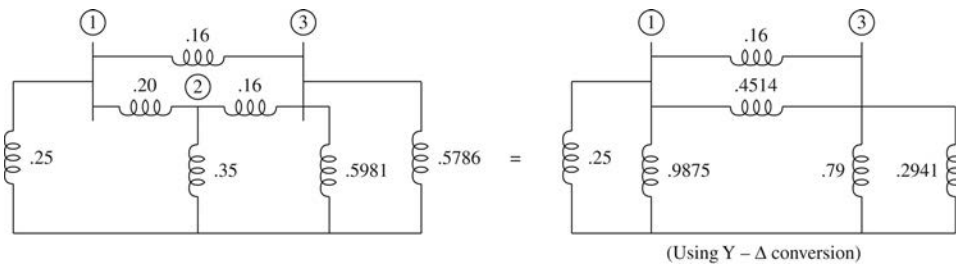

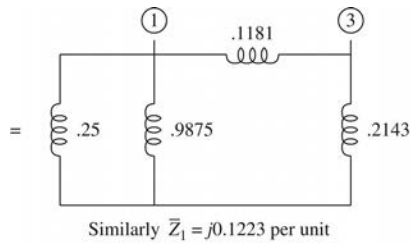

$$X_2 = 0.25 \parallel 0.9875 \parallel (0.1181 + 0.2143)$$

$$= 0.1247 \text{ per unit}$$

(c) Three-phase fault at bus 1.

Using the positive sequence thevenin equivalent from Problem 9.2:

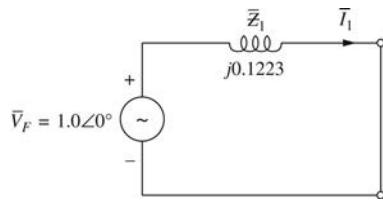

$$I_{base H} = \frac{S_{base 3\phi}}{\sqrt{3} V_{base H}} = \frac{1000}{\sqrt{3}(500)} = 1.155 \text{ kA}$$

$$\bar{I}_0 = \bar{I}_2 = 0$$

$$\bar{I}_1 = \frac{\bar{V}_F}{\bar{Z}_1} = \frac{1.0 \angle 0^\circ}{j0.1223} = -j8.177 \text{ per unit}$$

$$\begin{bmatrix} \bar{I}_A'' \\ \bar{I}_B'' \\ \bar{I}_C'' \end{bmatrix} = \begin{bmatrix} 1 & 1 & 1 \\ 1 & a^2 & a \\ 1 & a & a^2 \end{bmatrix} \begin{bmatrix} 0 \\ -j8.177 \\ 0 \end{bmatrix} = \begin{bmatrix} 8.177 \angle -90^\circ \\ 8.177 \angle 150^\circ \\ 8.177 \angle 30^\circ \end{bmatrix} \text{ per unit} \times 1.155$$

$$= \begin{bmatrix} 9.441 \angle -90^\circ \\ 9.441 \angle 150^\circ \\ 9.441 \angle 30^\circ \end{bmatrix} \text{ kA}$$

## 9.5 Calculation of per unit reactances

### Synchronous generators:

$$G1 \quad X_1 = X_d'' = (0.2) \left( \frac{1000}{500} \right) = 0.4 \quad X_0 = (0.10) \left( \frac{1000}{500} \right)$$

$$X_2 = X_d'' = 0.4 \quad = 0.20$$

$$G2 \quad X_1 = X_d'' = 0.18 \left( \frac{1000}{750} \right) = 0.24 \quad X_0 = 0.09 \left( \frac{1000}{750} \right)$$

$$X_2 = X_d'' = 0.24 \quad = 0.12$$

$$G3 \quad X_1 = 0.17 \quad X_2 = 0.20 \quad X_0 = 0.09$$

$$X_{base3} = \frac{(20)^2}{1000} = 0.4 \Omega \quad 3X_n = \frac{3(0.028)}{0.4} = 0.21 \text{ per unit}$$

### Transformers:

$$X_{T1} = 0.12 \left( \frac{1000}{500} \right) = 0.24$$

$$X_{T2} = 0.10 \left( \frac{1000}{750} \right) = 0.1333 \quad X_{T3} = 0.10$$

**Each Line:**

$$X_{baseH} = \frac{(500)^2}{1000} = 250 \Omega$$

$$X_1 = X_2 = \frac{50}{250} = 0.20 \text{ per unit}$$

$$X_0 = \frac{150}{250} = 0.60 \text{ per unit}$$

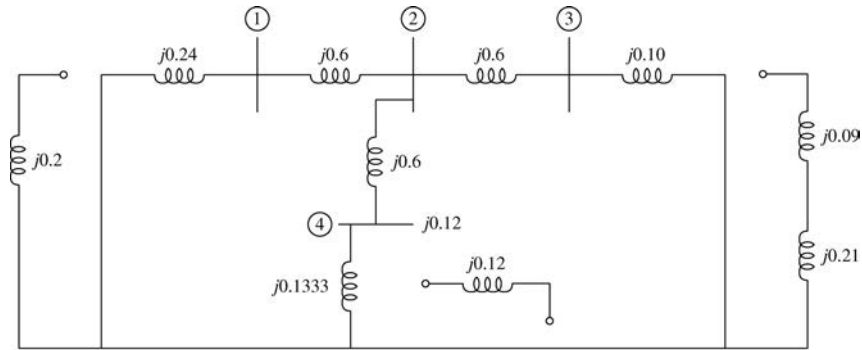

Per unit zero sequence network

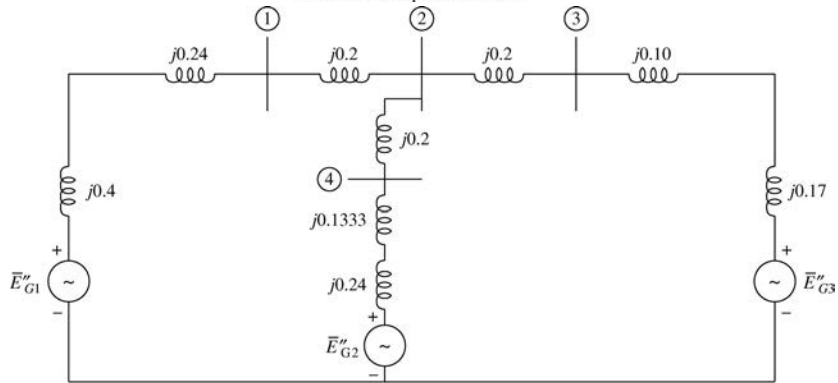

Per unit positive sequence network

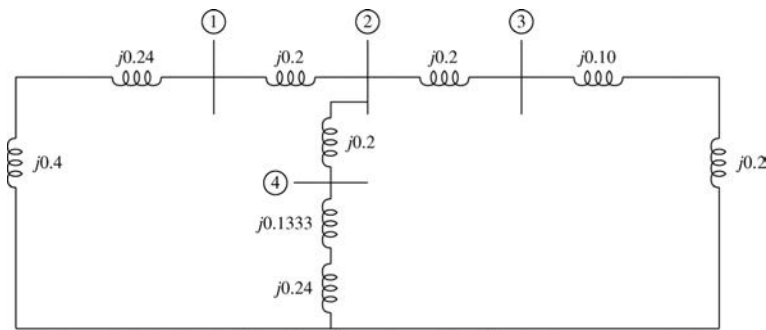

Per unit negative sequence network



9.6  $n = 1$  (Bus 1 = Fault Bus)

**Thevenin equivalents as viewed from Bus 1:**

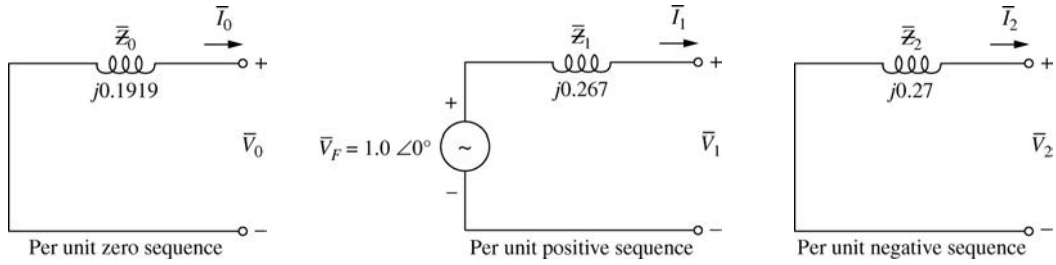

**Zero Sequence Thevenin equivalents:**

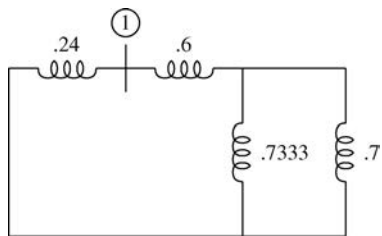

$$X_0 = 0.24 // [.6 + (.7333 // .7)]$$

$$X_0 = .24 // .9581 = 0.1919 \text{ per unit}$$

**Positive Sequence Thevenin equivalent:**

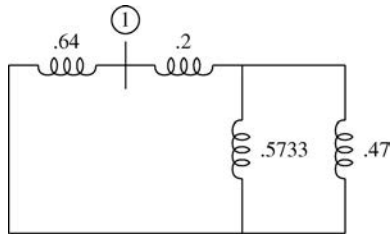

$$X_1 = .64 // [.2 + (.5733 // .47)]$$

$$X_1 = .64 // .4583$$

$$X_1 = 0.2670 \text{ per unit}$$

**Negative Sequence Thevenin equivalent:**

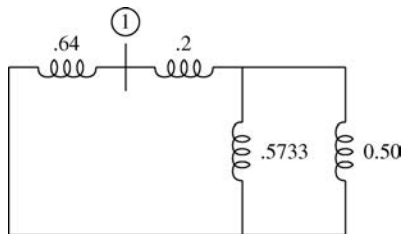

$$X_2 = .64 // [.2 + (.5733 // .50)]$$

$$X_2 = .64 // .4671 = 0.270 \text{ per unit}$$

9.7 Three-phase fault at bus 1.

**Using the positive-sequence Thevenin equivalent from Problem 9.5:**

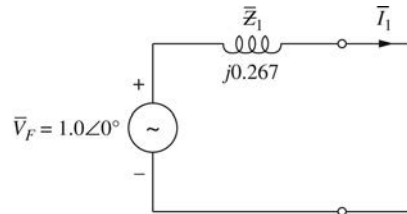

$$I_{base H} = \frac{1000}{500\sqrt{3}} = 1.155 \text{ kA}$$

$$\bar{I}_1 = \frac{\bar{V}_F}{\bar{Z}_1} = \frac{1.0\angle 0^\circ}{j0.267} = 3.745\angle -90^\circ \text{ per unit}$$

$$\bar{I}_0 = \bar{I}_2 = 0$$

$$\begin{bmatrix} \bar{I}_A'' \\ \bar{I}_B'' \\ \bar{I}_C'' \end{bmatrix} = \begin{bmatrix} 1 & 1 & 1 \\ 1 & a^2 & a \\ 1 & a & a^2 \end{bmatrix} \begin{bmatrix} 0 \\ 3.745\angle -90^\circ \\ 0 \end{bmatrix} = \begin{bmatrix} 3.745\angle -90^\circ \\ 3.745\angle 150^\circ \\ 3.745\angle 30^\circ \end{bmatrix} \text{ per unit}$$

$$\begin{bmatrix} \bar{I}_A'' \\ \bar{I}_B'' \\ \bar{I}_C'' \end{bmatrix} = \begin{bmatrix} 3.745\angle -90^\circ \\ 3.745\angle 150^\circ \\ 3.745\angle 30^\circ \end{bmatrix} \times 1.155 = \begin{bmatrix} 4.325\angle -90^\circ \\ 4.325\angle 150^\circ \\ 4.325\angle 30^\circ \end{bmatrix} \text{ kA}$$

9.8 Calculation of per unit reactances

**Synchronous generators:**

$$G1 \quad X_1 = X_d'' = 0.2 \left( \frac{12}{10} \right)^2 \left( \frac{100}{50} \right) \quad X_0 = (0.1) \left( \frac{12}{10} \right)^2 \left( \frac{100}{50} \right)$$

$$X_1 = 0.576 \text{ per unit} \quad X_0 = 0.288 \text{ per unit}$$

$$X_2 = X_1 = .576 \text{ per unit}$$

$$G2 \quad X_1 = X_d'' = 0.2 \quad X_0 = 0.1$$

$$X_2 = 0.23$$

**Transformers:**

$$X_{T1} = 0.1 \left( \frac{100}{50} \right) = 0.2 \text{ per unit}$$

$$X_{T2} = 0.1 \text{ per unit}$$

**Each line:**

$$\bar{Z}_{baseH} = \frac{(138)^2}{100} = 190.44 \Omega$$

$$X_1 = X_2 = \frac{40}{190.44} = 0.210 \text{ per unit}$$

$$X_0 = \frac{100}{190.44} = 0.5251 \text{ per unit}$$

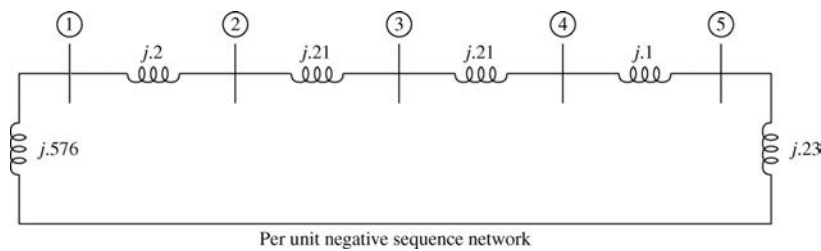
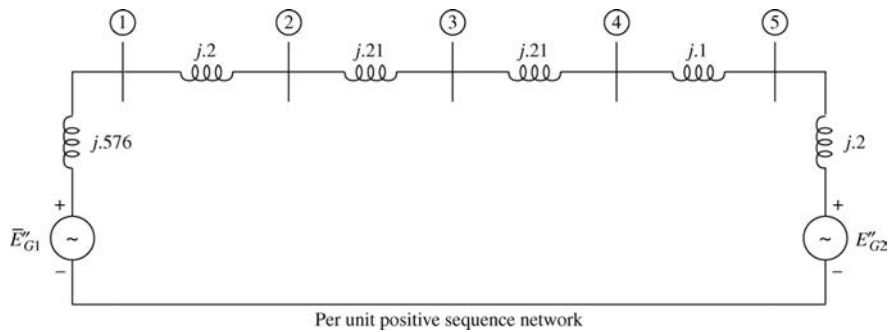
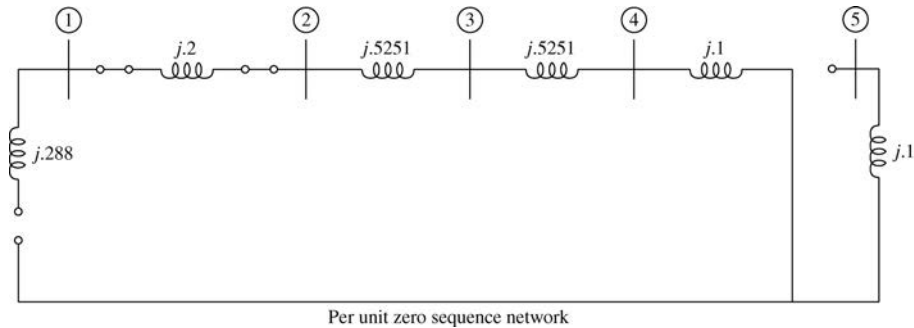

**9.9**  $n = 1$  (Bus 1 = Fault Bus) Thevenin equivalents as viewed from Bus 1:

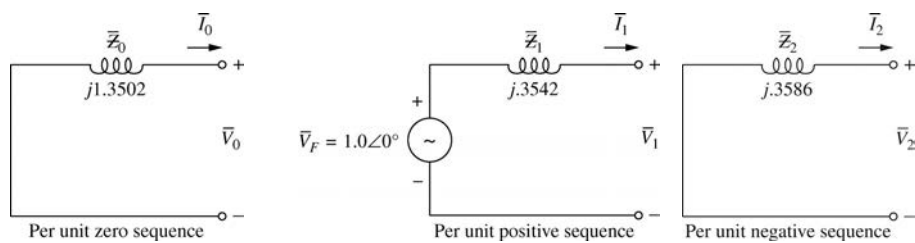

**Zero Sequence Thevenin equivalent:**

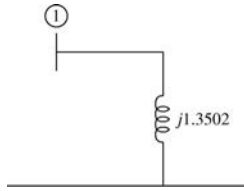

$$\bar{Z}_0 = j1.3502 \text{ per unit}$$

**Positive Sequence Thevenin equivalent:**

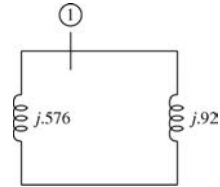

$$\bar{Z}_1 = j.576 // j.92 = j0.3542 \text{ per unit}$$

**Negative Sequence Thevenin equivalent:**

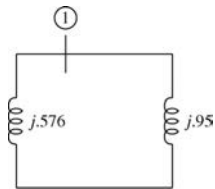

$$\bar{Z}_2 = j.576 // j.95 = j0.3586 \text{ per unit}$$

**9.10 Three-phase fault at bus 1.**

Using the positive-sequence Thevenin equivalent from Problem 9.9:

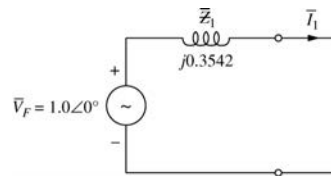

$$I_{base1} = \frac{100}{10\sqrt{3}} = 5.774 \text{ kA}$$

$$\bar{I}_1 = \frac{\bar{V}_F}{\bar{Z}_1} = \frac{1.0\angle 0^\circ}{j.3542} = 2.823\angle -90^\circ \text{ per unit}$$

$$\bar{I}_0 = \bar{I}_2 = 0$$

$$\begin{bmatrix} I_A'' \\ I_B'' \\ I_C'' \end{bmatrix} = \begin{bmatrix} 1 & 1 & 1 \\ 1 & a^2 & a \\ 1 & a & a^2 \end{bmatrix} \begin{bmatrix} 0 \\ 2.823\angle -90^\circ \\ 0 \end{bmatrix} = \begin{bmatrix} 2.823\angle -90^\circ \\ 2.823\angle 150^\circ \\ 2.823\angle 30^\circ \end{bmatrix} \text{ per unit}$$

$$\begin{bmatrix} I_A'' \\ I_B'' \\ I_C'' \end{bmatrix} = \begin{bmatrix} 2.823\angle -90^\circ \\ 2.823\angle 150^\circ \\ 2.823\angle 30^\circ \end{bmatrix} \times 5.774 = \begin{bmatrix} 16.30\angle -90^\circ \\ 16.30\angle 150^\circ \\ 16.30\angle 30^\circ \end{bmatrix} \text{ kA}$$

9.11 (a) The positive sequence network and steps in its reduction to its thévenin equivalent are shown below:

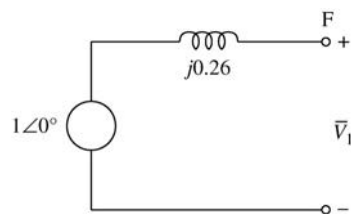
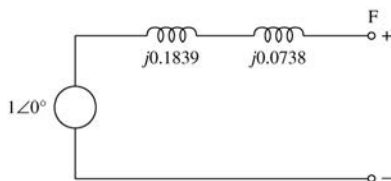
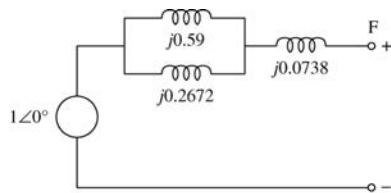
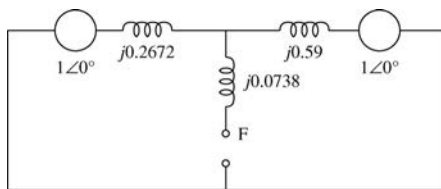
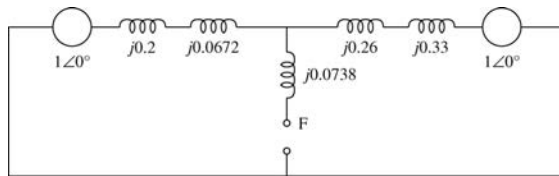
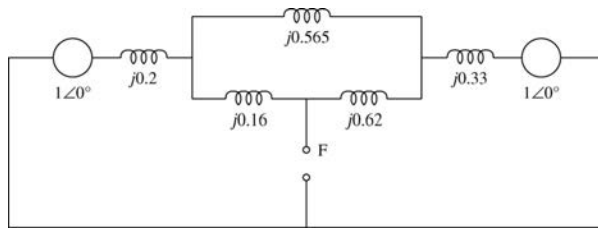
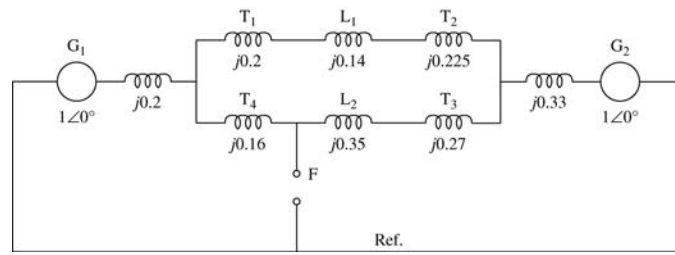

The negative sequence network and its reduction is shown below:

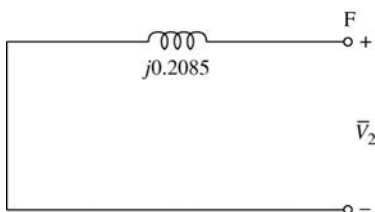
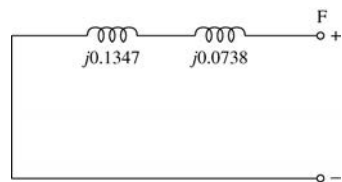
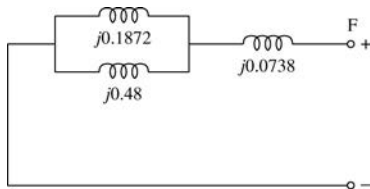
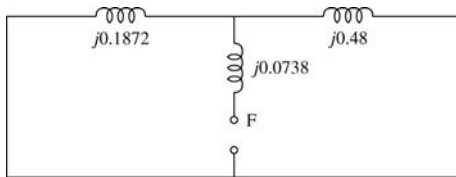
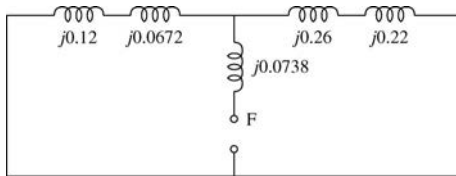
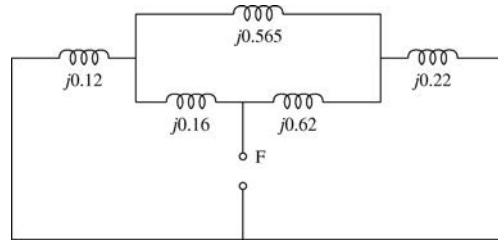
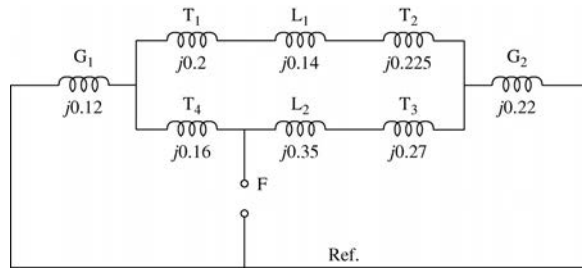

The zero-sequence network and its reduction are shown below:

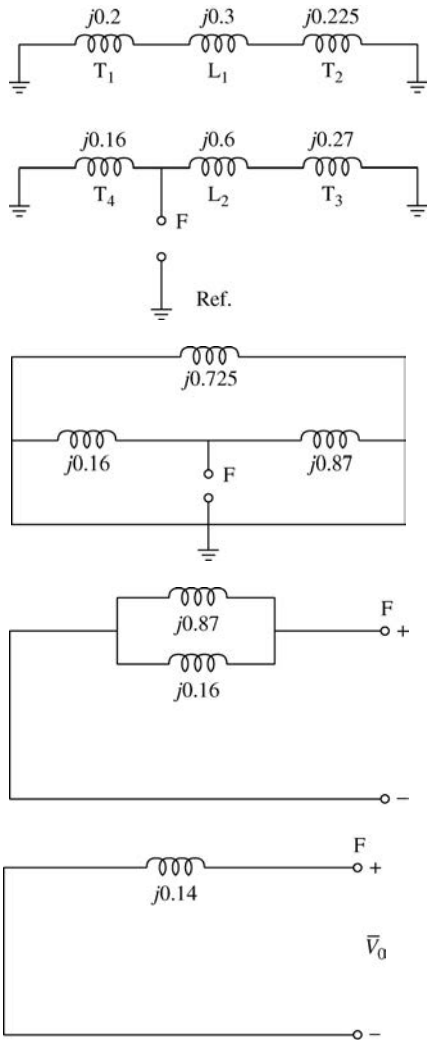

(b)

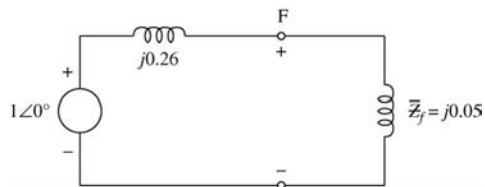

For a balanced 3-phase fault, only positive sequence network comes into picture.

$$\bar{I}_{sc} = \bar{I}_a = \bar{I}_{a1} = \frac{1\angle 0^\circ}{j(0.26 + 0.05)} = 3.23\angle -90^\circ$$

$$I_{sc} = 3.23 \text{ pu}$$

9.12 The zero-, positive-, and negative sequence networks are shown below:

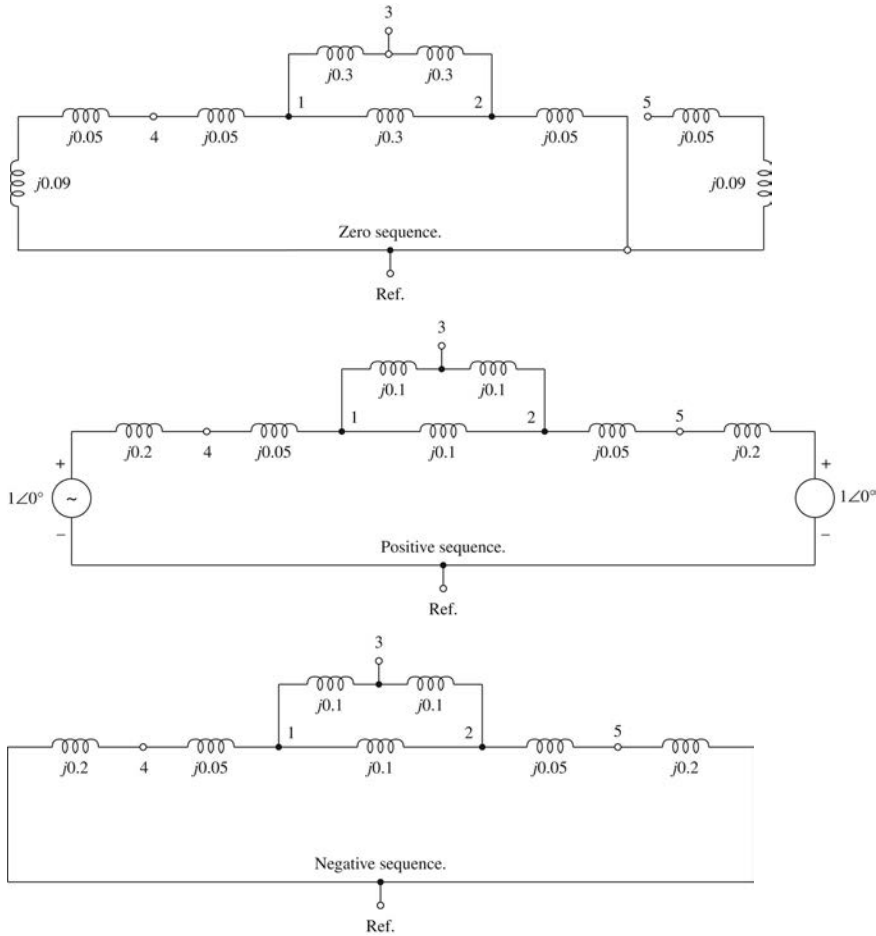

Using delta-wye transformation and series-parallel combinations, thévenin equivalents looking into bus 3 are shown below:

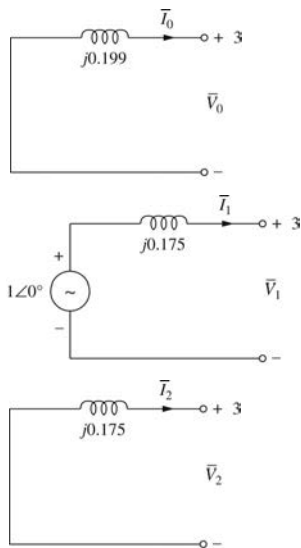



For a bolted 3-phase fault at bus 3,

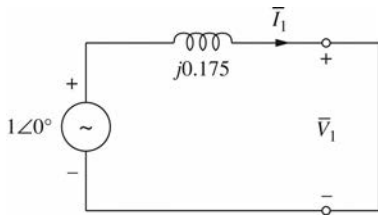

$$\bar{V}_1 = 0; \text{ Also } \bar{V}_2 = \bar{V}_0 = 0$$

$$\bar{I}_0 = 0; \bar{I}_2 = 0$$

$$\bar{I}_1 = \frac{1 \angle 0^\circ}{j0.175} = -j5.71$$

The fault current is 5.71 pu.

$$\begin{bmatrix} \bar{I}_a \\ \bar{I}_b \\ \bar{I}_c \end{bmatrix} = \begin{bmatrix} 1 & 1 & 1 \\ 1 & a^2 & a \\ 1 & a & a^2 \end{bmatrix} \begin{bmatrix} 0 \\ -j5.71 \\ 0 \end{bmatrix} = \begin{bmatrix} 5.71 \angle -90^\circ \\ 5.71 \angle 150^\circ \\ 5.71 \angle 30^\circ \end{bmatrix}$$

**9.13** For a balanced 3-phase fault at bus 3, we need the positive sequence impedance network reduced to its thevenin's equivalent viewed from bus 3. The development is shown below:

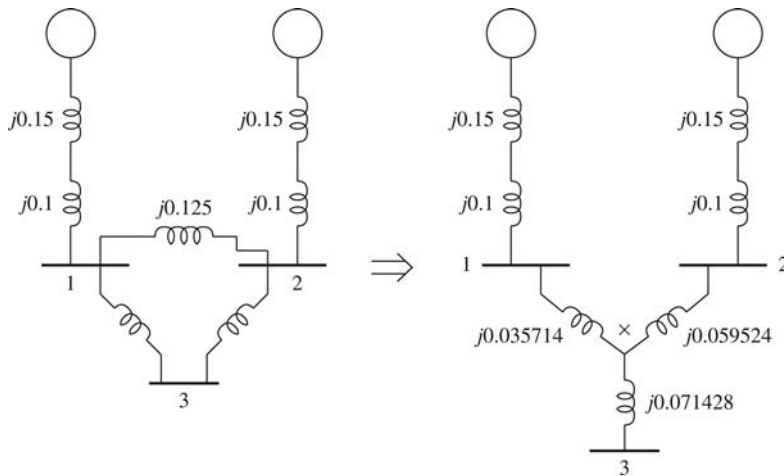

Convert the  $\Delta$  formed by buses 1, 2 and 3 to an equivalent Y

$$\bar{Z}_{1x} = \frac{(j0.125)(j0.15)}{j0.525} = j0.0357143$$

$$\bar{Z}_{2x} = \frac{(j0.125)(j0.25)}{j0.525} = j0.0595238$$

$$\bar{Z}_{3x} = \frac{(j0.15)(j0.25)}{j0.525} = j0.0714286$$

Using series-parallel combinations, the positive sequence Thévenin impedance is given by, viewed from bus 3:

$$\frac{(j0.2857143)(j0.3095238)}{j0.5952381} + j0.0714286$$

$$= j0.1485714 + j0.0714286 = j0.22$$

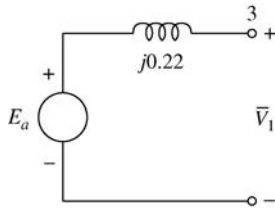

With the no-load generated EMF to be  $1\angle 0^\circ$  pu, the fault current is given by (with  $\bar{Z}_F = j0.1$ )

$$\bar{I}_a = \bar{I}_{a1} = \frac{1.0\angle 0^\circ}{j0.22 + j0.1}$$

$$= -j3.125 \text{ pu} = 820.1\angle -90^\circ \text{ A}$$

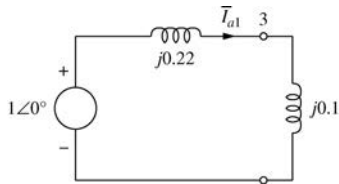

The fault current is 820.1 A.

#### 9.14 Bolted single-line-to-ground fault at bus 1.

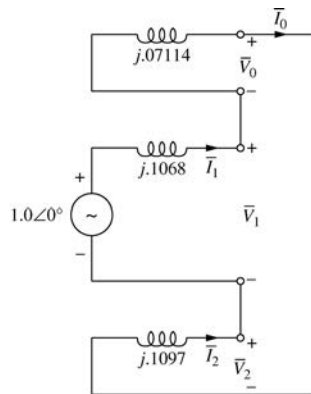

$$\bar{I}_0 = \bar{I}_1 = \bar{I}_2 = \frac{\bar{V}_F}{\bar{Z}_0 + \bar{Z}_1 + \bar{Z}_2}$$

$$= \frac{1.0\angle 0^\circ}{j(0.07114 + 0.1068 + 0.1097)}$$

$$= \frac{1.0\angle 0^\circ}{j0.2876} = -j3.4766 \text{ per unit}$$

$$\begin{bmatrix} \bar{I}_A'' \\ \bar{I}_B'' \\ \bar{I}_C'' \end{bmatrix} = \begin{bmatrix} 1 & 1 & 1 \\ 1 & a^2 & a \\ 1 & a & a^2 \end{bmatrix} \begin{bmatrix} -j3.4766 \\ -j3.4766 \\ -j3.4766 \end{bmatrix} = \begin{bmatrix} -j10.43 \\ 0 \\ 0 \end{bmatrix} \text{ per unit} = \begin{bmatrix} -j7.871 \\ 0 \\ 0 \end{bmatrix} \text{ kA}$$

Using Eq (9.1):

$$\begin{bmatrix} \bar{V}_0 \\ \bar{V}_1 \\ \bar{V}_2 \end{bmatrix} = \begin{bmatrix} 0 \\ 1.0\angle 0^\circ \\ 0 \end{bmatrix} - \begin{bmatrix} j0.07114 & 0 & 0 \\ 0 & j0.1068 & 0 \\ 0 & 0 & j0.1097 \end{bmatrix} \begin{bmatrix} -j3.4766 \\ -j3.4766 \\ -j3.4766 \end{bmatrix}$$

$$\begin{bmatrix} \bar{V}_0 \\ \bar{V}_1 \\ \bar{V}_2 \end{bmatrix} = \begin{bmatrix} -0.2473 \\ 0.6287 \\ -0.3814 \end{bmatrix} \text{ per unit}$$

$$\begin{bmatrix} \bar{V}_{Ag} \\ \bar{V}_{Bg} \\ \bar{V}_{Cg} \end{bmatrix} = \begin{bmatrix} 1 & 1 & 1 \\ 1 & a^2 & a \\ 1 & a & a^2 \end{bmatrix} \begin{bmatrix} -0.2473 \\ 0.6287 \\ -0.3814 \end{bmatrix} = \begin{bmatrix} 0 \\ 0.9502\angle 247.0^\circ \\ 0.9502\angle 113.0^\circ \end{bmatrix} \text{ per unit}$$

### 9.15 Single-Line-to Ground Arcing Fault at Bus 1.

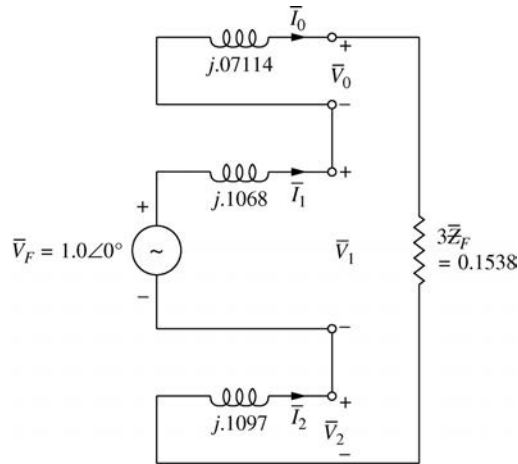

$$\bar{Z}_{baseH} = \frac{(765)^2}{1000} = 585.2 \Omega$$

$$\bar{Z}_F = \frac{30\angle 0^\circ}{585.2} = 0.05126\angle 0^\circ \text{ per unit}$$

$$\begin{aligned} \bar{I}_0 = \bar{I}_1 = \bar{I}_2 &= \frac{\bar{V}_F}{\bar{Z}_0 + \bar{Z}_1 + \bar{Z}_2 + 3\bar{Z}_F} \\ &= \frac{1.0\angle 0^\circ}{0.1538 + j0.2876} \\ &= \frac{1.0\angle 0^\circ}{0.3262\angle 61.86^\circ} = 3.0639\angle -61.86^\circ \text{ per unit} \end{aligned}$$

$$\begin{bmatrix} \bar{I}_A'' \\ \bar{I}_B'' \\ \bar{I}_C'' \end{bmatrix} = \begin{bmatrix} 1 & 1 & 1 \\ 1 & a^2 & a \\ 1 & a & a^2 \end{bmatrix} \begin{bmatrix} 3.0659 \angle -61.86^\circ \\ 3.0659 \angle -61.86^\circ \\ 3.0659 \angle -61.86^\circ \end{bmatrix} = \begin{bmatrix} 9.198 \angle -61.86^\circ \\ 0 \\ 0 \end{bmatrix} \text{ per unit}$$

$$= \begin{bmatrix} 6.942 \angle -61.86^\circ \\ 0 \\ 0 \end{bmatrix} \text{ kA}$$

$$\begin{bmatrix} \bar{V}_0 \\ \bar{V}_1 \\ \bar{V}_2 \end{bmatrix} = \begin{bmatrix} 0 \\ 1.0 \angle 0^\circ \\ 0 \end{bmatrix} - \begin{bmatrix} j0.07114 & 0 & 0 \\ 0 & j0.1068 & 0 \\ 0 & 0 & j0.1097 \end{bmatrix} \begin{bmatrix} 3.0659 \angle -61.86^\circ \\ 3.0659 \angle -61.86^\circ \\ 3.0659 \angle -61.86^\circ \end{bmatrix}$$

$$\begin{bmatrix} \bar{V}_0 \\ \bar{V}_1 \\ \bar{V}_2 \end{bmatrix} = \begin{bmatrix} 0.2181 \angle 208.14^\circ \\ 0.7279 \angle -12.25^\circ \\ 0.3363 \angle 208.14^\circ \end{bmatrix} \text{ per unit}$$

$$\begin{bmatrix} \bar{V}_{Ag} \\ \bar{V}_{Bg} \\ \bar{V}_{Cg} \end{bmatrix} = \begin{bmatrix} 1 & 1 & 1 \\ 1 & a^2 & a \\ 1 & a & a^2 \end{bmatrix} \begin{bmatrix} 0.2181 \angle 208.14^\circ \\ 0.7279 \angle -12.25^\circ \\ 0.3363 \angle 208.14^\circ \end{bmatrix} = \begin{bmatrix} 0.4717 \angle -61.85^\circ \\ 0.9099 \angle 244.2^\circ \\ 1.0105 \angle 113.52^\circ \end{bmatrix} \text{ per unit}$$

### 9.16 Bolted Line-to-Line Fault at Bus 1.

$$\bar{V}_F = 1.0 \angle 0^\circ$$

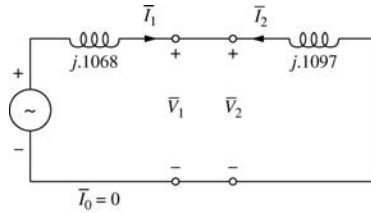

$$\bar{I}_1 = -\bar{I}_2 = \frac{\bar{V}_F}{\bar{Z}_1 + \bar{Z}_2}$$

$$= \frac{1.0 \angle 0^\circ}{j.2165}$$

$$= -j4.619 \text{ per unit}$$

$$\begin{bmatrix} \bar{I}_A'' \\ \bar{I}_B'' \\ \bar{I}_C'' \end{bmatrix} = \begin{bmatrix} 1 & 1 & 1 \\ 1 & a^2 & a \\ 1 & a & a^2 \end{bmatrix} \begin{bmatrix} 0 \\ -j4.619 \\ +j4.619 \end{bmatrix} = \begin{bmatrix} 0 \\ 8.000 \angle 180^\circ \\ 8.000 \angle 0^\circ \end{bmatrix} \text{ per unit} = \begin{bmatrix} 0 \\ 6.038 \angle 180^\circ \\ 6.038 \angle 0^\circ \end{bmatrix} \text{ kA}$$

$$\begin{bmatrix} \bar{V}_0 \\ \bar{V}_1 \\ \bar{V}_2 \end{bmatrix} = \begin{bmatrix} 0 \\ 1 \angle 0^\circ \\ 0 \end{bmatrix} - \begin{bmatrix} j.07114 & 0 & 0 \\ 0 & j0.1068 & 0 \\ 0 & 0 & j0.1097 \end{bmatrix} \begin{bmatrix} 0 \\ -j4.619 \\ -j4.619 \end{bmatrix} = \begin{bmatrix} 0 \\ 0.5067 \\ 0.5067 \end{bmatrix} \text{ per unit}$$

$$\begin{bmatrix} \bar{V}_{Ag} \\ \bar{V}_{Bg} \\ \bar{V}_{Cg} \end{bmatrix} = \begin{bmatrix} 1 & 1 & 1 \\ 1 & a^2 & a \\ 1 & a & a^2 \end{bmatrix} \begin{bmatrix} 0 \\ 0.5067 \\ 0.5067 \end{bmatrix} = \begin{bmatrix} 1.013 \angle 0^\circ \\ 0.5067 \angle 180^\circ \\ 0.5067 \angle 180^\circ \end{bmatrix} \text{ per unit}$$

**9.17 Bolted double-line-to-ground fault at bus 1.**

$$\bar{V}_F = 1.0 \angle 0^\circ$$

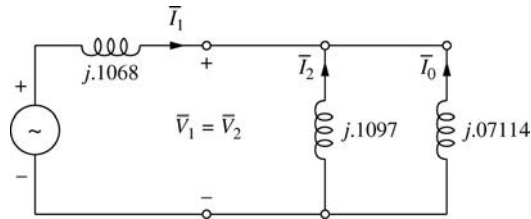

$$\begin{aligned} \bar{I}_1 &= \frac{\bar{V}_F}{\bar{Z}_1 + \bar{Z}_2 // \bar{Z}_0} \\ &= \frac{1.0 \angle 0^\circ}{j(.1068 + .1097 // .0711)} \\ &= \frac{1.0 \angle 0^\circ}{j0.14995} \\ &= 6.669 \angle -90^\circ \text{ per unit} \end{aligned}$$

$$\bar{I}_2 = -\bar{I}_1 \left( \frac{\bar{Z}_0}{\bar{Z}_0 + \bar{Z}_2} \right) = j6.669 \left( \frac{.07114}{.18084} \right)$$

$$\bar{I}_2 = j2.623 \text{ per unit}$$

$$\bar{I}_0 = -\bar{I}_1 \left( \frac{\bar{Z}_2}{\bar{Z}_0 + \bar{Z}_2} \right) = j6.669 \left( \frac{.1097}{.18084} \right) = j4.046 \text{ per unit}$$

$$\begin{bmatrix} \bar{I}_A'' \\ \bar{I}_B'' \\ \bar{I}_C'' \end{bmatrix} = \begin{bmatrix} 1 & 1 & 1 \\ 1 & a^2 & a \\ 1 & a & a^2 \end{bmatrix} \begin{bmatrix} j4.046 \\ -j6.669 \\ j2.623 \end{bmatrix} = \begin{bmatrix} 0 \\ 10.08 \angle 143.0^\circ \\ 10.08 \angle 37.02^\circ \end{bmatrix} \text{ per unit} = \begin{bmatrix} 0 \\ 7.607 \angle 143^\circ \\ 7.607 \angle 37^\circ \end{bmatrix} \text{ kA}$$

$$\begin{bmatrix} \bar{V}_0 \\ \bar{V}_1 \\ \bar{V}_2 \end{bmatrix} = \begin{bmatrix} 0 \\ 1 \angle 0^\circ \\ 0 \end{bmatrix} - \begin{bmatrix} j0.07114 & 0 & 0 \\ 0 & j0.1068 & 0 \\ 0 & 0 & j0.1097 \end{bmatrix} \begin{bmatrix} j4.046 \\ -j6.669 \\ j2.623 \end{bmatrix} = \begin{bmatrix} 0.2878 \\ 0.2878 \\ 0.2878 \end{bmatrix} \text{ per unit}$$

$$\begin{bmatrix} \bar{V}_{Ag} \\ \bar{V}_{Bg} \\ \bar{V}_{Cg} \end{bmatrix} = \begin{bmatrix} 1 & 1 & 1 \\ 1 & a^2 & a \\ 1 & a & a^2 \end{bmatrix} \begin{bmatrix} 0.2878 \\ 0.2878 \\ 0.2878 \end{bmatrix} = \begin{bmatrix} 0.8633 \\ 0 \\ 0 \end{bmatrix} \text{ per unit}$$

9.18

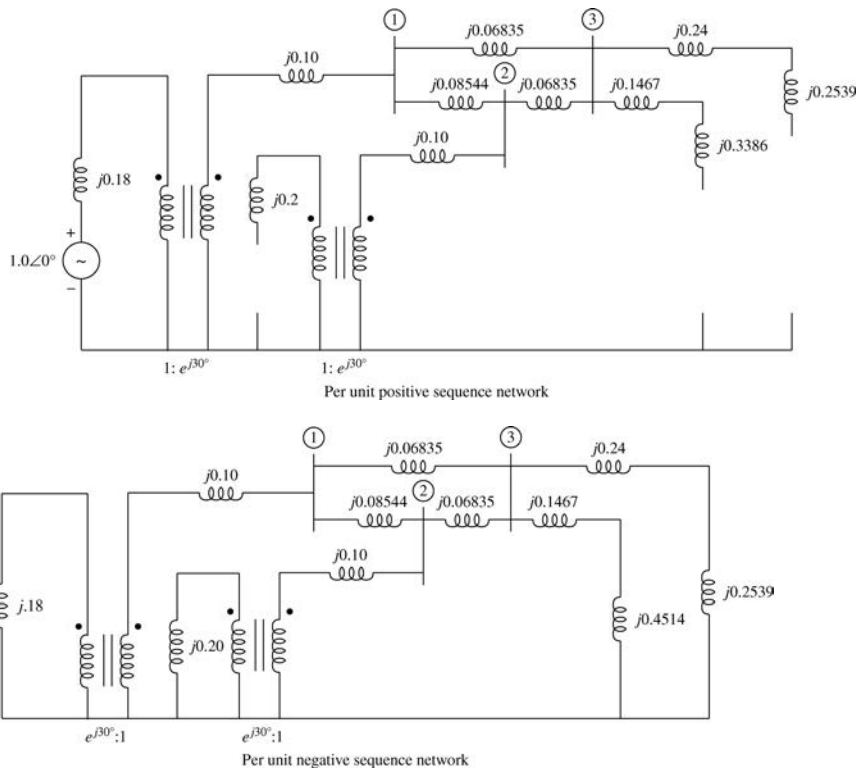

The zero sequence network is the same as in Problem 9.1.

The  $\Delta - Y$  transformer phase shifts have no effect on the fault currents and no effect on the voltages at the fault bus. Therefore, from the results of Problem 9.10:

$$\begin{bmatrix} \bar{I}_A'' \\ \bar{I}_B'' \\ \bar{I}_C'' \end{bmatrix} = \begin{bmatrix} -j10.43 \\ 0 \\ 0 \end{bmatrix} \text{ per unit} = \begin{bmatrix} -j7.871 \\ 0 \\ 0 \end{bmatrix} \text{ kA} \quad \begin{bmatrix} \bar{V}_{Ag} \\ \bar{V}_{Bg} \\ \bar{V}_{Cg} \end{bmatrix} = \begin{bmatrix} 0 \\ 0.9502 \angle 247.0^\circ \\ 0.9502 \angle 113.0^\circ \end{bmatrix} \text{ per unit}$$

Contributions to the fault from generator 1:

From the zero-sequence network:  $\bar{I}_{G1-0} = 0$

From the positive sequence network, using current division:

$$\begin{aligned} \bar{I}_{G1-1} &= (-j3.4766) \left( \frac{.1727}{.28 + .1727} \right) \angle -30^\circ \\ &= 1.326 \angle -120^\circ \text{ per unit} \end{aligned}$$

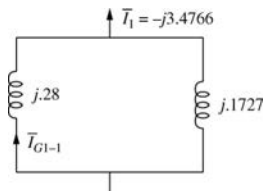

From the negative sequence network, using current division:

$$\begin{aligned} \bar{I}_{G1-2} &= (-j3.4766) \left( \frac{.1802}{.28 + .1802} \right) \angle +30^\circ \\ &= 1.3615 \angle -60^\circ \text{ per unit} \end{aligned}$$

Transforming to the phase domain:

$$\begin{aligned} \begin{bmatrix} \bar{I}_{G1-A}'' \\ \bar{I}_{G1-B}'' \\ \bar{I}_{G1-C}'' \end{bmatrix} &= \begin{bmatrix} 1 & 1 & 1 \\ 1 & a^2 & a \\ 1 & a & a^2 \end{bmatrix} \begin{bmatrix} 0 \\ 1.326 \angle -120^\circ \\ 1.326 \angle -60^\circ \end{bmatrix} = \begin{bmatrix} 2.328 \angle -89.6^\circ \\ 2.328 \angle 89.6^\circ \\ 0.036 \angle 180^\circ \end{bmatrix} \text{ per unit} \\ &= \begin{bmatrix} 1.757 \angle -89.6^\circ \\ 1.757 \angle 89.6^\circ \\ 0.027 \angle 180^\circ \end{bmatrix} \text{ kA} \end{aligned}$$

**9.19** (a) Bolted single-line-to-ground fault at bus 1.

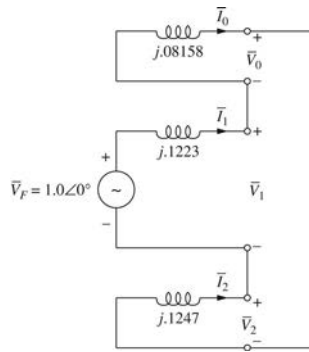

$$\begin{aligned} \bar{I}_0 = \bar{I}_1 = \bar{I}_2 &= \frac{\bar{V}_F}{\bar{Z}_0 + \bar{Z}_1 + \bar{Z}_2} \\ &= \frac{1.0 \angle 0^\circ}{j(.08158 + .1223 + .1247)} = \frac{1.0 \angle 0^\circ}{j0.3286} \\ &= -j3.043 \text{ per unit} \end{aligned}$$

$$\begin{aligned} \begin{bmatrix} \bar{I}_A'' \\ \bar{I}_B'' \\ \bar{I}_C'' \end{bmatrix} &= \begin{bmatrix} 1 & 1 & 1 \\ 1 & a^2 & a \\ 1 & a & a^2 \end{bmatrix} \begin{bmatrix} -j3.043 \\ -j3.043 \\ -j3.043 \end{bmatrix} = \begin{bmatrix} -j9.130 \\ 0 \\ 0 \end{bmatrix} \text{ per unit} \\ &= \begin{bmatrix} -j10.54 \\ 0 \\ 0 \end{bmatrix} \text{ kA} \end{aligned}$$

Using Eq. (9.1):

$$\begin{aligned} \begin{bmatrix} \bar{V}_0 \\ \bar{V}_1 \\ \bar{V}_2 \end{bmatrix} &= \begin{bmatrix} 0 \\ 1.0 \angle 0^\circ \\ 0 \end{bmatrix} - \begin{bmatrix} j.08158 & 0 & 0 \\ 0 & j.1223 & 0 \\ 0 & 0 & j.1247 \end{bmatrix} \begin{bmatrix} -j3.043 \\ -j3.043 \\ -j3.043 \end{bmatrix} \\ &= \begin{bmatrix} -0.2483 \\ 0.6278 \\ -0.3795 \end{bmatrix} \text{ per unit} \end{aligned}$$

$$\begin{aligned} \begin{bmatrix} \bar{V}_{Ag} \\ \bar{V}_{Bg} \\ \bar{V}_{Cg} \end{bmatrix} &= \begin{bmatrix} 1 & 1 & 1 \\ 1 & a^2 & a \\ 1 & a & a^2 \end{bmatrix} \begin{bmatrix} -0.2483 \\ .6278 \\ -0.3795 \end{bmatrix} = \begin{bmatrix} 0 \\ 0.9485 \angle 246.9^\circ \\ 0.9485 \angle 113.1^\circ \end{bmatrix} \text{ per unit} \end{aligned}$$

(b) Single-line-to-ground arcing fault at bus 1.

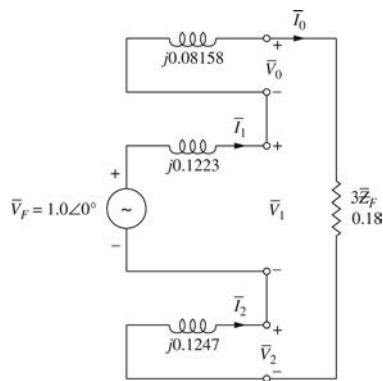

$$Z_{baseH} = \frac{(500)^2}{1000} = 250 \Omega$$

$$Z_F = \frac{15}{250} = 0.06 \angle 0^\circ \text{ per unit}$$

$$\begin{aligned} \bar{I}_0 = \bar{I}_1 = \bar{I}_2 &= \frac{\bar{V}_F}{\bar{Z}_0 + \bar{Z}_1 + \bar{Z}_2 + 3\bar{Z}_F} \\ &= \frac{1.0 \angle 0^\circ}{0.18 + j0.3286} = \frac{1.0 \angle 0^\circ}{0.3747 \angle 61.29^\circ} \\ &= 2.669 \angle -61.29^\circ \text{ per unit} \end{aligned}$$

$$\begin{aligned} \begin{bmatrix} \bar{I}_A'' \\ \bar{I}_B'' \\ \bar{I}_C'' \end{bmatrix} &= \begin{bmatrix} 1 & 1 & 1 \\ 1 & a^2 & a \\ 1 & a & a^2 \end{bmatrix} \begin{bmatrix} 2.669 \angle -61.29^\circ \\ 2.669 \angle -61.29^\circ \\ 2.669 \angle -61.29^\circ \end{bmatrix} = \begin{bmatrix} 8.007 \angle -61.29^\circ \\ 0 \\ 0 \end{bmatrix} \text{ per unit} \times 1.155 \\ &= \begin{bmatrix} 9.246 \angle -61.29^\circ \\ 0 \\ 0 \end{bmatrix} \text{ kA} \end{aligned}$$

$$\begin{aligned} \begin{bmatrix} \bar{V}_0 \\ \bar{V}_1 \\ \bar{V}_2 \end{bmatrix} &= \begin{bmatrix} 0 \\ 1.0 \angle 0^\circ \\ 0 \end{bmatrix} - \begin{bmatrix} j0.08158 & 0 & 0 \\ 0 & j0.1223 & 0 \\ 0 & 0 & j0.1247 \end{bmatrix} \begin{bmatrix} 2.669 \angle -61.29^\circ \\ 2.669 \angle -61.29^\circ \\ 2.669 \angle -61.29^\circ \end{bmatrix} \\ &= \begin{bmatrix} 0.2177 \angle 208.71^\circ \\ 0.7307 \angle -12.9^\circ \\ 0.3328 \angle 208.71^\circ \end{bmatrix} \text{ per unit} \end{aligned}$$

$$\begin{aligned} \begin{bmatrix} \bar{V}_{Ag} \\ \bar{V}_{Bg} \\ \bar{V}_{Cg} \end{bmatrix} &= \begin{bmatrix} 1 & 1 & 1 \\ 1 & a^2 & a \\ 1 & a & a^2 \end{bmatrix} \begin{bmatrix} .2177 \angle 208.71^\circ \\ .7307 \angle -12.4^\circ \\ .3328 \angle 208.71^\circ \end{bmatrix} = \begin{bmatrix} 0.4804 \angle -61.29^\circ \\ 0.9094 \angle 244.0^\circ \\ 1.009 \angle 113.6^\circ \end{bmatrix} \text{ per unit} \end{aligned}$$

(c)

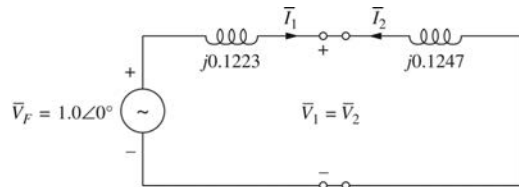

$$\begin{aligned} \bar{I}_1 = -\bar{I}_2 &= \frac{\bar{V}_F}{\bar{Z}_1 + \bar{Z}_2} \\ &= \frac{1.0 \angle 0^\circ}{j(0.1223 + 0.1247)} = -j4.0486 \end{aligned}$$



$$\begin{bmatrix} \bar{I}_A'' \\ \bar{I}_B'' \\ \bar{I}_C'' \end{bmatrix} = \begin{bmatrix} 1 & 1 & 1 \\ 1 & a^2 & a \\ 1 & a & a^2 \end{bmatrix} \begin{bmatrix} 0 \\ -j4.0486 \\ +j4.0486 \end{bmatrix} = \begin{bmatrix} 0 \\ 7.012 \angle 180^\circ \\ 7.012 \angle 0^\circ \end{bmatrix} \text{ per unit} \times 1.155$$

$$= \begin{bmatrix} 0^\circ \\ -8.097 \\ 8.097 \end{bmatrix} \text{ kA}$$

$$\begin{bmatrix} \bar{V}_0 \\ \bar{V}_1 \\ \bar{V}_2 \end{bmatrix} = \begin{bmatrix} 0 \\ 1.0 \angle 0^\circ \\ 0 \end{bmatrix} - \begin{bmatrix} j.08158 & 0 & 0 \\ 0 & j.1223 & 0 \\ 0 & 0 & j.1247 \end{bmatrix} \begin{bmatrix} 0 \\ -j4.0486 \\ +j4.0486 \end{bmatrix}$$

$$= \begin{bmatrix} 0 \\ 0.5049 \\ 0.5049 \end{bmatrix} \text{ per unit}$$

$$\begin{bmatrix} \bar{V}_{Ag} \\ \bar{V}_{Bg} \\ \bar{V}_{Cg} \end{bmatrix} = \begin{bmatrix} 1 & 1 & 1 \\ 1 & a^2 & a \\ 1 & a & a^2 \end{bmatrix} \begin{bmatrix} 0 \\ .5049 \\ .5049 \end{bmatrix} = \begin{bmatrix} 1.010 \angle 0^\circ \\ 0.5049 \angle 180^\circ \\ 0.5049 \angle 180^\circ \end{bmatrix} \text{ per unit}$$

(d)

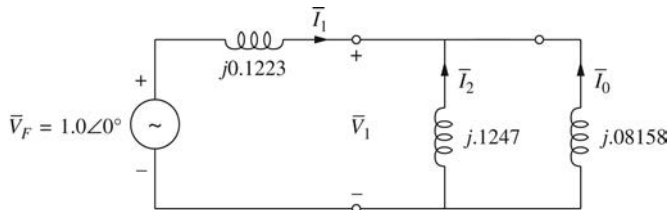

$$\bar{I}_1 = \frac{\bar{V}_F}{\bar{Z}_1 + \bar{Z}_2 // \bar{Z}_0}$$

$$= \frac{1.0 \angle 0^\circ}{j(.1223 + .1247 // .0816)}$$

$$= \frac{1.0 \angle 0^\circ}{j0.1716}$$

$$= -j5.827 \text{ per unit}$$

$$\bar{I}_2 = -\bar{I}_1 \left( \frac{\bar{Z}_0}{\bar{Z}_0 + \bar{Z}_2} \right) = j5.827 \left( \frac{.08158}{.2063} \right)$$

$$\bar{I}_2 = j2.304 \text{ per unit}$$

$$\bar{I}_0 = -\bar{I}_1 \left( \frac{\bar{Z}_2}{\bar{Z}_0 + \bar{Z}_2} \right) = j5.827 \left( \frac{.1247}{.2063} \right) = j3.523 \text{ per unit}$$

$$\begin{bmatrix} \bar{I}_A'' \\ \bar{I}_B'' \\ \bar{I}_C'' \end{bmatrix} = \begin{bmatrix} 1 & 1 & 1 \\ 1 & a^2 & a \\ 1 & a & a^2 \end{bmatrix} \begin{bmatrix} j3.523 \\ -j5.827 \\ j2.304 \end{bmatrix} = \begin{bmatrix} 0 \\ 8.804 \angle 143.1^\circ \\ 8.304 \angle 36.9^\circ \end{bmatrix} \text{ per unit} \times 1.155$$

$$= \begin{bmatrix} 0^\circ \\ 10.17 \angle 143.1 \\ 10.17 \angle 36.9^\circ \end{bmatrix} \text{ kA}$$

$$\begin{bmatrix} \bar{V}_0 \\ \bar{V}_1 \\ \bar{V}_2 \end{bmatrix} = \begin{bmatrix} 0 \\ 1.0\angle 0^\circ \\ 0 \end{bmatrix} - \begin{bmatrix} j0.08158 & 0 & 0 \\ 0 & j.1223 & 0 \\ 0 & 0 & j.1247 \end{bmatrix} \begin{bmatrix} j3.523 \\ -j5.827 \\ j2.304 \end{bmatrix}$$

$$= \begin{bmatrix} 0.2874 \\ 0.2874 \\ 0.2874 \end{bmatrix} \text{ per unit}$$

$$\begin{bmatrix} \bar{V}_{Ag} \\ \bar{V}_{Bg} \\ \bar{V}_{Cg} \end{bmatrix} = \begin{bmatrix} 1 & 1 & 1 \\ 1 & a^2 & a \\ 1 & a & a^2 \end{bmatrix} \begin{bmatrix} .2874 \\ .2874 \\ .2874 \end{bmatrix} = \begin{bmatrix} 0.8622\angle 0^\circ \\ 0 \\ 0 \end{bmatrix} \text{ per unit}$$

(e)

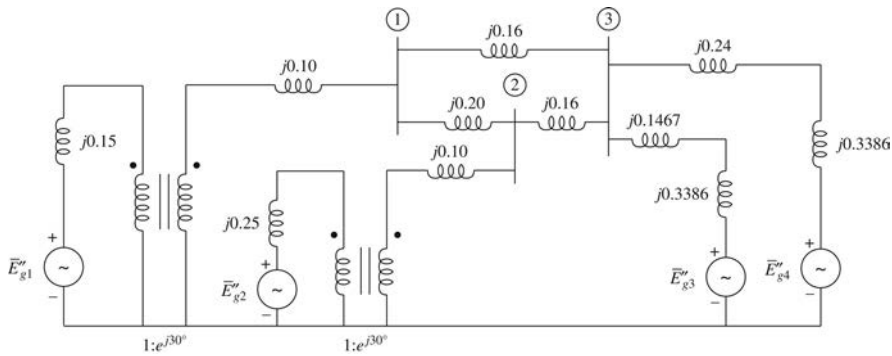

Per unit positive sequence network

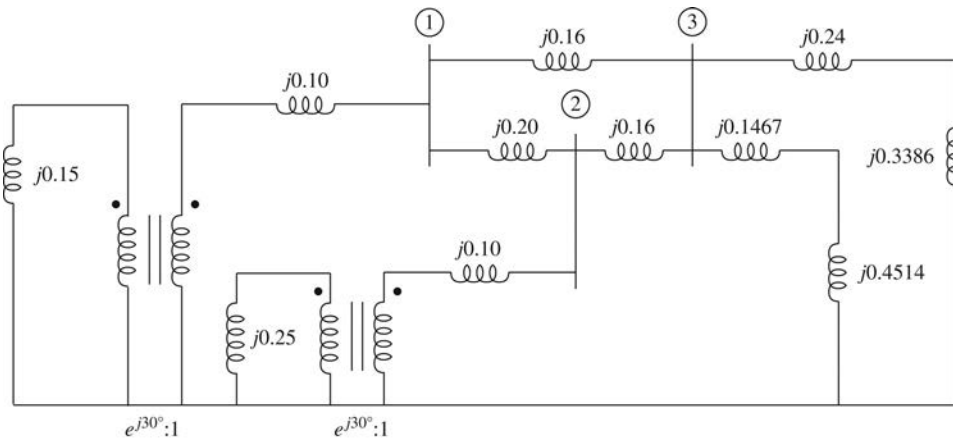

Per unit negative sequence network

The per unit zero sequence network is the same as in Problem 9.1

The  $\Delta - Y$  transformer phase shifts have no effect on the fault currents and no effect on the voltages at the fault bus. Therefore, from the results of Problem 9.19(a),

$$\begin{bmatrix} \bar{I}_A'' \\ \bar{I}_B'' \\ \bar{I}_C'' \end{bmatrix} = \begin{bmatrix} -j9.130 \\ 0 \\ 0 \end{bmatrix} \text{ per unit} = \begin{bmatrix} -j10.54 \\ 0 \\ 0 \end{bmatrix} \text{ kA} \quad \begin{bmatrix} \bar{V}_{Ag} \\ \bar{V}_{Bg} \\ \bar{V}_{Cg} \end{bmatrix} = \begin{bmatrix} 0 \\ 0.9485 \angle 246.90^\circ \\ 0.9485 \angle 113.1^\circ \end{bmatrix} \text{ per unit}$$

Contribution to the fault current from generator 1:

From the zero-sequence circuit:  $\bar{I}_{G1-0} = 0$

From the positive sequence circuit, using current division:

$$\begin{aligned} \bar{I}_{G1-1} &= (-j3.043) \left( \frac{.2393}{.25 + .2393} \right) \angle -30^\circ \\ &= 1.488 \angle -120^\circ \text{ per unit} \end{aligned}$$

Transformer phase shift

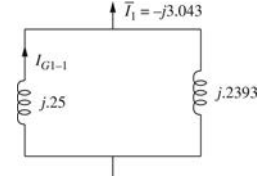

From the negative sequence circuit, using current division:

$$\begin{aligned} \bar{I}_{G1-2} &= (-j3.043) \left( \frac{.2487}{.25 + .2487} \right) \angle +30^\circ \\ &= 1.518 \angle -60^\circ \text{ per unit} \end{aligned}$$

Transformer phase shift

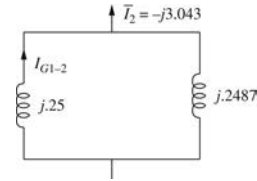

Transforming to the phase domain:

$$\begin{bmatrix} \bar{I}_{G1-A}'' \\ \bar{I}_{G1-B}'' \\ \bar{I}_{G1-C}'' \end{bmatrix} = \begin{bmatrix} 1 & 1 & 1 \\ 1 & a^2 & a \\ 1 & a & a^2 \end{bmatrix} \begin{bmatrix} 0 \\ 1.488 \angle -120^\circ \\ 1.518 \angle -60^\circ \end{bmatrix} = \begin{bmatrix} 2.603 \angle -89.7^\circ \\ 2.603 \angle 89.7^\circ \\ 0.03 \angle 180^\circ \end{bmatrix} \text{ per unit}$$

$$= \begin{bmatrix} 3.006 \angle 87.7^\circ \\ 3.006 \angle 87.7^\circ \\ 0.035 \angle 180^\circ \end{bmatrix} \text{ kA}$$

9.20

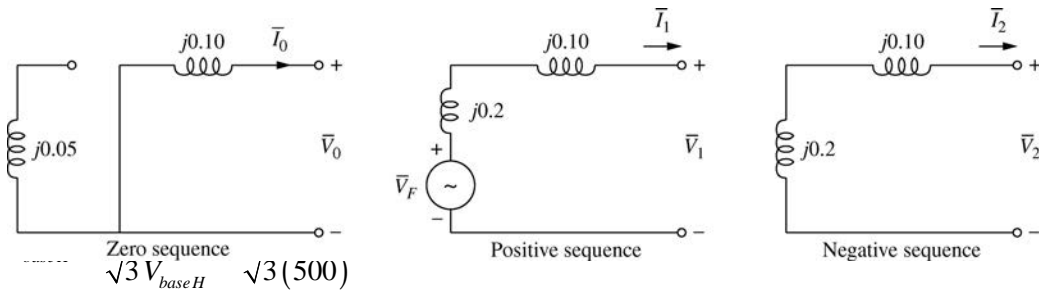

**Three-phase fault:**

$$\begin{aligned} \bar{I}_0 = \bar{I}_2 = 0 \quad \bar{I}_1 &= \frac{\bar{V}_F}{\bar{Z}_1} = \frac{1.0 \angle 0^\circ}{j0.30} \\ &= -j3.333 \text{ per unit} \end{aligned}$$

$$\begin{aligned}\bar{I}_a'' = \bar{I}_1 &= -j3.333 \text{ per unit} \\ &= \underline{\underline{-j1.925 \text{ kA}}}\end{aligned}$$

**Single line-to-ground fault:**

$$\begin{aligned}\bar{I}_0 = \bar{I}_1 = \bar{I}_2 &= \frac{\bar{V}_F}{\bar{Z}_0 + \bar{Z}_1 + \bar{Z}_2} = \frac{1.0 \angle 0^\circ}{j(0.1 + 0.3 + 0.3)} = -j1.429 \text{ per unit} \\ \bar{I}_a'' = 3\bar{I}_0 &= -j4.286 \text{ per unit} = \underline{\underline{-j2.474 \text{ kA}}}\end{aligned}$$

**Line-to-line fault:**

$$\begin{aligned}\bar{I}_0 &= 0 \quad \bar{I}_1 = -\bar{I}_2 = \frac{\bar{V}_F}{\bar{Z}_1 + \bar{Z}_2} = \frac{1.0 \angle 0^\circ}{j(0.3 + 0.3)} = -j1.667 \text{ per unit} \\ \bar{I}_b'' &= (a^2 - a)\bar{I}_1 = (a^2 - a)(-j1.667) = 2.887 \angle 180^\circ \text{ per unit} \\ \bar{I}_b'' &= \underline{\underline{1.667 \angle 180^\circ \text{ kA}}}\end{aligned}$$

**Double line-to-ground fault:**

$$\begin{aligned}\bar{I}_1 &= \frac{\bar{V}_F}{\bar{Z}_1 + \bar{Z}_2 \parallel \bar{Z}_0} = \frac{1.0 \angle 0^\circ}{j(0.3 + 0.3 \parallel 0.1)} = \frac{1.0}{j0.375} = -j2.667 \text{ per unit} \\ \bar{I}_2 &= -\bar{I}_1 \left( \frac{\bar{Z}_0}{\bar{Z}_0 + \bar{Z}_2} \right) = (j2.667) \left( \frac{.1}{.4} \right) = j0.667 \text{ per unit} \\ \bar{I}_0 &= -\bar{I}_1 \left( \frac{\bar{Z}_2}{\bar{Z}_0 + \bar{Z}_2} \right) = (j2.667) \left( \frac{.3}{.4} \right) = j2.0 \text{ per unit} \\ \bar{I}_B'' &= \bar{I}_c + a^2 \bar{I}_1 + a \bar{I}_2 = 2.0 \angle 90^\circ + 2.667 \angle 150^\circ + .667 \angle 210^\circ = 4.163 \angle 134^\circ \text{ per unit} \\ &= \underline{\underline{2.404 \angle 134^\circ \text{ kA}}}\end{aligned}$$

**9.21 Bolted single-line-to-ground fault at bus 1.**

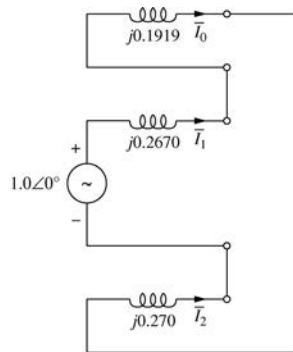

$$\begin{aligned}\bar{I}_0 = \bar{I}_1 = \bar{I}_2 &= \frac{\bar{V}_F}{\bar{Z}_0 + \bar{Z}_1 + \bar{Z}_2} \\ &= \frac{1.0 \angle 0^\circ}{j(0.1919 + 0.267 + 0.27)} = -j1.372 \text{ per unit}\end{aligned}$$

$$\begin{bmatrix} \bar{I}_A'' \\ \bar{I}_B'' \\ \bar{I}_C'' \end{bmatrix} = \begin{bmatrix} 1 & 1 & 1 \\ 1 & a^2 & a \\ 1 & a & a^2 \end{bmatrix} \begin{bmatrix} -j1.372 \\ -j1.372 \\ -j1.372 \end{bmatrix}$$

$$\begin{bmatrix} \bar{I}_A'' \\ \bar{I}_B'' \\ \bar{I}_C'' \end{bmatrix} = \begin{bmatrix} -j4.116 \\ 0 \\ 0 \end{bmatrix} \text{ per unit} = \begin{bmatrix} -j4.753 \\ 0 \\ 0 \end{bmatrix} \text{ kA}$$

Contributions to the fault current

**Zero sequence:**

$$\begin{aligned} \text{Transformer: } \bar{I}_{T-0} &= -j1.372 \left( \frac{.9581}{.24 + .9581} \right) \\ &= -j1.097 \text{ per unit} \end{aligned}$$

$$\text{Line: } \bar{I}_{L-0} = -j1.372 \left( \frac{.24}{.24 + .9581} \right) = -j0.2748$$

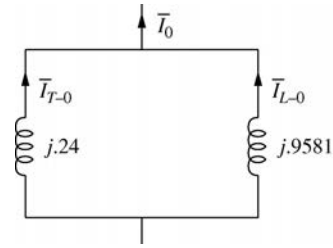

**Positive sequence:**

$$\begin{aligned} \text{Transformer: } \bar{I}_{T-1} &= -j1.372 \left( \frac{.4583}{.64 + .4583} \right) \\ &= -j0.5725 \end{aligned}$$

$$\text{Line: } \bar{I}_{L-1} = -j1.372 \left( \frac{.64}{.64 + .4583} \right) = -j0.7994$$

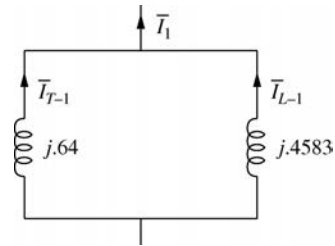

**Negative sequence:**

$$\begin{aligned} \text{Transformer: } \bar{I}_{T-2} &= -j1.372 \left( \frac{.4671}{.64 + .4671} \right) \\ &= -j0.5789 \text{ per unit} \end{aligned}$$

$$\text{Line: } \bar{I}_{L-2} = j1.372 \left( \frac{.64}{.64 + .4671} \right) = -j0.7931 \text{ per unit}$$

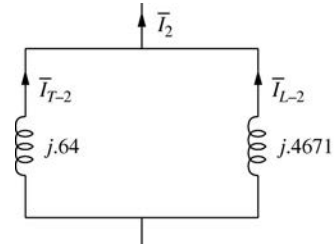

**Transformer:**

$$\begin{bmatrix} I''_{T-A} \\ I''_{T-B} \\ I''_{T-C} \end{bmatrix} = \begin{bmatrix} 1 & 1 & 1 \\ 1 & a^2 & a \\ 1 & a & a^2 \end{bmatrix} \begin{bmatrix} -j1.097 \\ -j0.5725 \\ -j0.5789 \end{bmatrix} = \begin{bmatrix} -j2.248 \\ .521 \angle -89.4^\circ \\ .521 \angle -90.6^\circ \end{bmatrix} \text{ per unit} = \begin{bmatrix} -j2.596 \\ .602 \angle -89.4^\circ \\ .602 \angle -90.6^\circ \end{bmatrix} \text{ kA}$$

**Line:**

$$\begin{bmatrix} I''_{L-A} \\ I''_{L-B} \\ I''_{L-C} \end{bmatrix} = \begin{bmatrix} 1 & 1 & 1 \\ 1 & a^2 & a \\ 1 & a & a^2 \end{bmatrix} \begin{bmatrix} -j0.2748 \\ -j0.7994 \\ -j0.7931 \end{bmatrix} = \begin{bmatrix} -j1.8673 \\ .521 \angle 90.6^\circ \\ .521 \angle 89.4^\circ \end{bmatrix} \text{ per unit} = \begin{bmatrix} -j2.156 \\ .602 \angle 90.6^\circ \\ .602 \angle 89.4^\circ \end{bmatrix} \text{ kA}$$

**9.22 Bolted line-to-line fault at bus 1.**

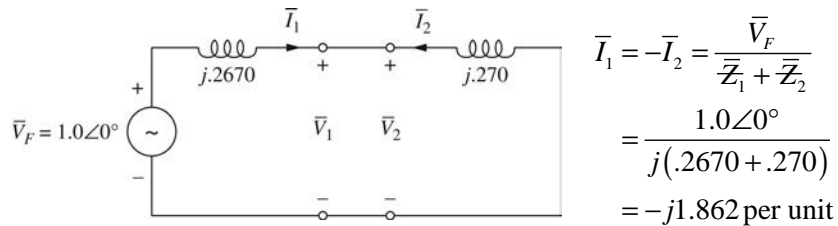

$$\begin{bmatrix} \bar{I}_A'' \\ \bar{I}_B'' \\ \bar{I}_C'' \end{bmatrix} = \begin{bmatrix} 1 & 1 & 1 \\ 1 & a^2 & a \\ 1 & a & a^2 \end{bmatrix} \begin{bmatrix} 0 \\ -j1.862 \\ +j1.862 \end{bmatrix} = \begin{bmatrix} 0 \\ 3.225\angle 180^\circ \\ 3.225\angle 0^\circ \end{bmatrix} \text{ per unit}$$

$$\begin{bmatrix} \bar{I}_A'' \\ \bar{I}_B'' \\ \bar{I}_C'' \end{bmatrix} = \begin{bmatrix} 0 \\ 3.225\angle 180^\circ \\ 3.225\angle 0^\circ \end{bmatrix} \times 1.155 = \begin{bmatrix} 0 \\ 3.724\angle 180^\circ \\ 3.724\angle 0^\circ \end{bmatrix} \text{ kA}$$

Contributions to the fault current

**Zero sequence:**

$$\bar{I}_{T-0} = \bar{I}_{L-0} = 0$$

**Positive sequence:**

$$\begin{aligned} \text{Transformer: } \bar{I}_{T-1} &= -j1.862 \left( \frac{.4583}{.64 + .4583} \right) \\ &= -j0.7770 \text{ per unit} \end{aligned}$$

$$\text{Line: } \bar{I}_{L-1} = -j1.862 \left( \frac{.64}{.64 + .4583} \right) = -j1.085 \text{ per unit}$$

**Negative sequence:**

$$\begin{aligned} \text{Transformer } \bar{I}_{T-2} &= j1.862 \left( \frac{.4671}{.64 + .4671} \right) \\ &= j0.7856 \text{ per unit} \end{aligned}$$

$$\begin{aligned} \text{Line } \bar{I}_{L-2} &= j1.862 \left( \frac{.64}{.64 + .4671} \right) \\ &= j1.076 \text{ per unit} \end{aligned}$$

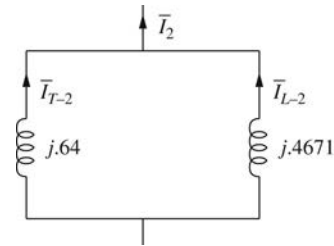
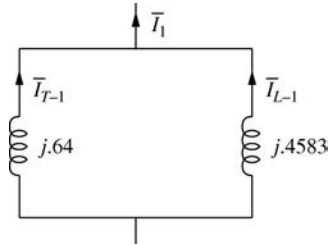

Contribution to fault from transformer:

$$\begin{bmatrix} \bar{I}_{T-A}'' \\ \bar{I}_{T-B}'' \\ \bar{I}_{T-C}'' \end{bmatrix} = \begin{bmatrix} 1 & 1 & 1 \\ 1 & a^2 & a \\ 1 & a & a^2 \end{bmatrix} \begin{bmatrix} 0 \\ -j.777 \\ j.7856 \end{bmatrix} = \begin{bmatrix} j.0086 \\ 1.353\angle 180.2^\circ \\ 1.353\angle -0.2^\circ \end{bmatrix} \text{ per unit} = \begin{bmatrix} 0.0099\angle 90^\circ \\ 1.562\angle 180.2^\circ \\ 1.562\angle -0.2^\circ \end{bmatrix} \text{ kA}$$

Contribution to fault from line:

$$\begin{bmatrix} \bar{I}_{L-A}'' \\ \bar{I}_{L-B}'' \\ \bar{I}_{L-C}'' \end{bmatrix} = \begin{bmatrix} 1 & 1 & 1 \\ 1 & a^2 & a \\ 1 & a & a^2 \end{bmatrix} \begin{bmatrix} 0 \\ -j1.085 \\ j1.076 \end{bmatrix} = \begin{bmatrix} -j0.0086 \\ 1.871\angle 179.9^\circ \\ 1.871\angle 0.1^\circ \end{bmatrix} \text{ per unit} = \begin{bmatrix} 0.0099\angle -90^\circ \\ 2.160\angle 179.9^\circ \\ 2.160\angle 0.1^\circ \end{bmatrix} \text{ kA}$$

### 9.23 Bolted double-line-to-ground fault at bus 1.

$$\bar{V}_F = 1.0 \angle 0^\circ$$

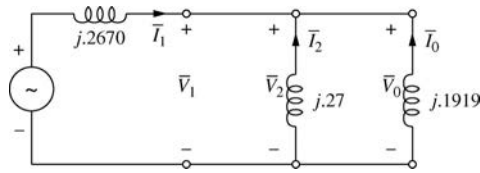

$$\bar{I}_1 = \frac{\bar{V}_F}{\bar{Z}_1 + \bar{Z}_2 \parallel \bar{Z}_0}$$

$$\bar{I}_1 = \frac{1.0 \angle 0^\circ}{j(.267 + .27 \parallel .1919)}$$

$$= \frac{1.0 \angle 0^\circ}{j0.3792}$$

$$= -j2.637 \text{ per unit}$$

$$\bar{I}_2 = -\bar{I}_1 \left( \frac{\bar{Z}_0}{\bar{Z}_0 + \bar{Z}_2} \right) = j2.637 \left( \frac{.1919}{.27 + .1919} \right)$$

$$\bar{I}_2 = j1.096 \text{ per unit}$$

$$\bar{I}_0 = -\bar{I}_1 \left( \frac{\bar{Z}_2}{\bar{Z}_0 + \bar{Z}_2} \right) = j2.637 \left( \frac{.27}{.27 + .1919} \right)$$

$$\bar{I}_0 = j1.541 \text{ per unit}$$

$$\begin{bmatrix} \bar{I}_A'' \\ \bar{I}_B'' \\ \bar{I}_C'' \end{bmatrix} = \begin{bmatrix} 1 & 1 & 1 \\ 1 & a^2 & a \\ 1 & a & a^2 \end{bmatrix} \begin{bmatrix} j1.541 \\ -j2.637 \\ j1.096 \end{bmatrix} = \begin{bmatrix} 0 \\ 3.975 \angle 144.3^\circ \\ 3.975 \angle 35.57^\circ \end{bmatrix} \text{ per unit} \times 1.155$$

$$= \begin{bmatrix} 0 \\ 4.590 \angle 144.3^\circ \\ 4.590 \angle 35.57^\circ \end{bmatrix} \text{ kA}$$

Contributions to the fault current

#### Zero sequence:

$$\text{Transformer: } \bar{I}_{T-0} = j1.541 \left( \frac{.9581}{.24 + .9581} \right)$$

$$= j1.232 \text{ per unit}$$

$$\text{Line: } \bar{I}_{L-0} = j1.541 \left( \frac{.24}{.24 + .9581} \right) = j0.3087 \text{ per unit}$$

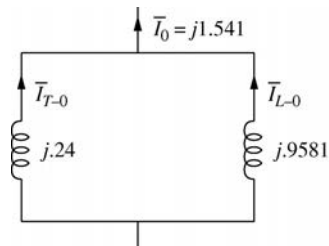

#### Positive sequence:

$$\bar{I}_{T-1} = (-j2.637) \left( \frac{.4583}{.64 + .4583} \right) = -j1.100$$

$$\bar{I}_{L-1} = (-j2.637) \left( \frac{.64}{.64 + .4583} \right) = -j1.537 \text{ per unit}$$

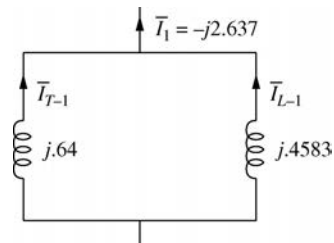

**Negative Sequence:**

$$\bar{I}_{T-2} = (j1.096) \left( \frac{.4671}{.64 + .4671} \right) = j0.4624$$

$$\bar{I}_{L-2} = (j1.096) \left( \frac{.64}{.64 + .4671} \right) = j0.6336$$

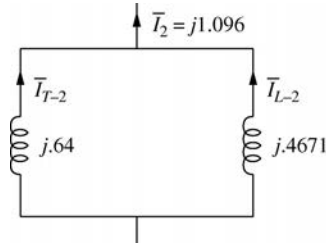

Contribution to fault from transformer:

$$\begin{bmatrix} \bar{I}_{T-A}'' \\ \bar{I}_{T-B}'' \\ \bar{I}_{T-C}'' \end{bmatrix} = \begin{bmatrix} 1 & 1 & 1 \\ 1 & a^2 & a \\ 1 & a & a^2 \end{bmatrix} \begin{bmatrix} j1.232 \\ -j1.10 \\ j0.4624 \end{bmatrix} = \begin{bmatrix} j0.5944 \\ 2.058 \angle 131.1^\circ \\ 2.058 \angle 48.90^\circ \end{bmatrix} \text{ per unit} \times 1.155$$

$$= \begin{bmatrix} 0.6864 \angle 90^\circ \\ 2.376 \angle 131.1^\circ \\ 2.376 \angle 48.90^\circ \end{bmatrix} \text{ kA}$$

Contributions to fault from line:

$$\begin{bmatrix} \bar{I}_{L-A}'' \\ \bar{I}_{L-B}'' \\ \bar{I}_{L-C}'' \end{bmatrix} = \begin{bmatrix} 1 & 1 & 1 \\ 1 & a^2 & a \\ 1 & a & a^2 \end{bmatrix} \begin{bmatrix} j.3087 \\ -j1.537 \\ j.6336 \end{bmatrix} = \begin{bmatrix} -j.594 \\ 2.028 \angle 158.0^\circ \\ 2.028 \angle 22.0^\circ \end{bmatrix} \text{ per unit} \times 1.155$$

$$= \begin{bmatrix} 0.686 \angle -90^\circ \\ 2.342 \angle 158^\circ \\ 2.342 \angle 22^\circ \end{bmatrix} \text{ kA}$$

**9.24 Bolted single-line-to-ground fault at bus 1.**

$$\bar{V}_F = 1.0 \angle 0^\circ$$

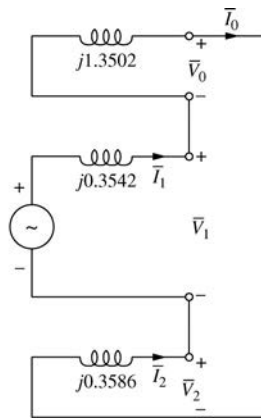

$$\bar{I}_0 = \bar{I}_1 = \bar{I}_2 = \frac{\bar{V}_F}{\bar{Z}_0 + \bar{Z}_1 + \bar{Z}_2}$$

$$= \frac{1.0 \angle 0^\circ}{j(1.3502 + 0.3542 + 0.3586)}$$

$$= -j0.4847 \text{ per unit}$$

$$I_{base1} = \frac{100}{10\sqrt{3}} = 5.774 \text{ kA}$$

$$\begin{bmatrix} \bar{I}_A'' \\ \bar{I}_B'' \\ \bar{I}_C'' \end{bmatrix} = \begin{bmatrix} 1 & 1 & 1 \\ 1 & a^2 & a \\ 1 & a & a^2 \end{bmatrix} \begin{bmatrix} -j.4847 \\ -j.4847 \\ -j.4847 \end{bmatrix} = \begin{bmatrix} -j1.454 \\ 0 \\ 0 \end{bmatrix} \text{ per unit} \times 5.774 = \begin{bmatrix} -j8.396 \\ 0 \\ 0 \end{bmatrix} \text{ kA}$$

Contributions to fault current



**Zero sequence:**

Generator G1  $\bar{I}_{G1-0} = 0$

Transformer T1  $\bar{I}_{T1-0} = -j0.4847$  per unit

**Positive sequence:**

Generator G1  $\bar{I}_{G1-1} = -j.4847 \left( \frac{.92}{.92 + .576} \right)$   
 $= -j0.2981$  per unit

Transformer T1  $\bar{I}_{T1-1} = -j.4847 \left( \frac{.576}{.92 + .576} \right) = -j0.1866$  per unit

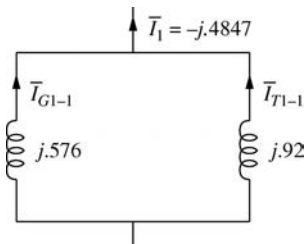

**Negative sequence:**

Generator G1  $\bar{I}_{G1-2} = -j.4847 \left( \frac{.95}{.95 + .576} \right)$   
 $= -j0.3017$  per unit

Transformer T1  $\bar{I}_{T1-2} = -j.4847 \left( \frac{.576}{.576 + .95} \right)$   
 $= -j.1830$

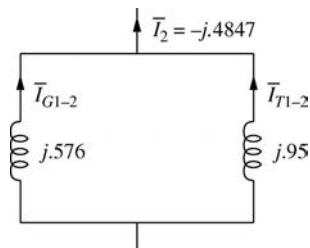

Contribution to fault from generator G1:

$$\begin{aligned} \begin{bmatrix} \bar{I}_{G1-A}'' \\ \bar{I}_{G1-B}'' \\ \bar{I}_{G1-C}'' \end{bmatrix} &= \begin{bmatrix} 1 & 1 & 1 \\ 1 & a^2 & a \\ 1 & a & a^2 \end{bmatrix} \begin{bmatrix} 0 \\ -j.2981 \\ -j.3017 \end{bmatrix} = \begin{bmatrix} -j0.5998 \\ 0.2999 \angle 89.4^\circ \\ 0.2999 \angle 90.6^\circ \end{bmatrix} \text{ per unit} \times 5.774 \\ &= \begin{bmatrix} 3.463 \angle -90^\circ \\ 1.731 \angle 89.4^\circ \\ 1.731 \angle 90.6^\circ \end{bmatrix} \text{ kA} \end{aligned}$$

Contribution to fault from transformer T1:

$$\begin{aligned} \begin{bmatrix} \bar{I}_{T1-A}'' \\ \bar{I}_{T1-B}'' \\ \bar{I}_{T1-C}'' \end{bmatrix} &= \begin{bmatrix} 1 & 1 & 1 \\ 1 & a^2 & a \\ 1 & a & a^2 \end{bmatrix} \begin{bmatrix} -j.4847 \\ -j.1866 \\ -j.1830 \end{bmatrix} = \begin{bmatrix} -j.8543 \\ 0.2999 \angle -90.6^\circ \\ 0.2999 \angle -89.4^\circ \end{bmatrix} \text{ per unit} \times 5.774 \\ &= \begin{bmatrix} 4.932 \angle -90^\circ \\ 1.731 \angle -90.6^\circ \\ 1.731 \angle -89.4^\circ \end{bmatrix} \text{ kA} \end{aligned}$$

9.25 Arcing simple-line-to-ground fault at bus 1.

$$\bar{V}_F = 1.0 \angle 0^\circ$$

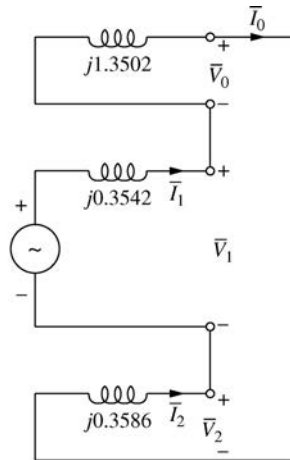

$$\begin{aligned} \bar{I}_0 = \bar{I}_1 = \bar{I}_2 &= \frac{\bar{V}_F}{\bar{Z}_0 + \bar{Z}_1 + \bar{Z}_2 + 3\bar{Z}_F} \\ &= \frac{1.0 \angle 0^\circ}{0.15 + j(1.3502 + .3542 + .3586)} \\ &= \frac{1.0 \angle 0^\circ}{2.068 \angle 85.84^\circ} \\ &= 0.4834 \angle -85.84^\circ \text{ per unit} \end{aligned}$$

$$\begin{aligned} \begin{bmatrix} \bar{I}_A'' \\ \bar{I}_B'' \\ \bar{I}_C'' \end{bmatrix} &= \begin{bmatrix} 1 & 1 & 1 \\ 1 & a^2 & a \\ 1 & a & a^2 \end{bmatrix} \begin{bmatrix} .4834 \angle 85.84^\circ \\ .4834 \angle 85.84^\circ \\ .4834 \angle 85.84^\circ \end{bmatrix} = \begin{bmatrix} 1.450 \angle 85.84^\circ \\ 0 \\ 0 \end{bmatrix} \text{ per unit} \times 5.774 \\ &= \begin{bmatrix} 8.374 \angle 85.84^\circ \\ 0 \\ 0 \end{bmatrix} \text{ kA} \end{aligned}$$

Contributions to fault current

**Zero sequence:**

Generator G1:  $\bar{I}_{G1-0} = 0$

Transformer T1:  $\bar{I}_{T1-0} = 0.4834 \angle -85.84^\circ$  per unit

**Positive sequence:**

Generator G1:  $\bar{I}_{G1-1} = .4834 \angle -85.84^\circ \left( \frac{.92}{.92 + .576} \right)$   
 $= 0.2973 \angle -85.84^\circ$

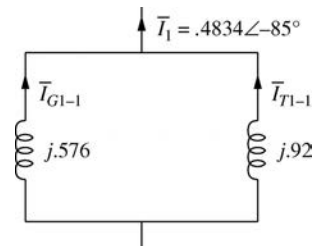

$$\begin{aligned} \text{Transformer T1: } \bar{I}_{T1-1} &= .4834 \angle -85.84^\circ \left( \frac{.576}{.92 + .576} \right) \\ &= 0.1861 \angle -85.84^\circ \text{ per unit} \end{aligned}$$

**Negative sequence:**

$$\begin{aligned} \text{Generator G1: } \bar{I}_{G1-2} &= .4834 \angle -85.84^\circ \left( \frac{.95}{.576 + .95} \right) \\ &= 0.3009 \angle -85.84^\circ \end{aligned}$$

$$\begin{aligned} \text{Transformer T1: } \bar{I}_{T1-2} &= .4834 \angle -85.84^\circ \left( \frac{.576}{.576 + .95} \right) \\ &= 0.1825 \angle -85.84^\circ \text{ per unit} \end{aligned}$$

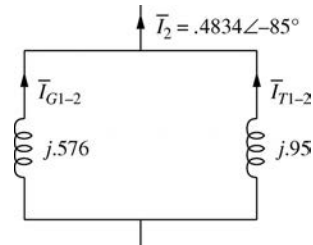

Contribution to fault from generator G1:

$$\begin{aligned} \begin{bmatrix} \bar{I}_{G1-A}'' \\ \bar{I}_{G1-B}'' \\ \bar{I}_{G1-C}'' \end{bmatrix} &= \begin{bmatrix} 1 & 1 & 1 \\ 1 & a^2 & a \\ 1 & a & a^2 \end{bmatrix} \begin{bmatrix} 0 \\ 0.2973 \angle -85.84^\circ \\ 0.3009 \angle -85.84^\circ \end{bmatrix} = \begin{bmatrix} .5982 \angle -85.84^\circ \\ .2991 \angle 93.56^\circ \\ .2991 \angle 94.76^\circ \end{bmatrix} \text{ per unit} \times 5.774 \\ &= \begin{bmatrix} 3.454 \angle -85.84^\circ \\ 1.727 \angle 93.56^\circ \\ 1.727 \angle 94.76^\circ \end{bmatrix} \text{ kA} \end{aligned}$$

Contribution to fault from generator T1:

$$\begin{aligned} \begin{bmatrix} \bar{I}_{T1-A}'' \\ \bar{I}_{T1-B}'' \\ \bar{I}_{T1-C}'' \end{bmatrix} &= \begin{bmatrix} 1 & 1 & 1 \\ 1 & a^2 & a \\ 1 & a & a^2 \end{bmatrix} \begin{bmatrix} .4834 \angle -85.84^\circ \\ .1861 \angle -85.84^\circ \\ .1825 \angle -85.84^\circ \end{bmatrix} = \begin{bmatrix} 0.852 \angle -85.84^\circ \\ 0.2991 \angle -86.44^\circ \\ 0.2991 \angle -85.24^\circ \end{bmatrix} \text{ per unit} \times 5.774 \\ &= \begin{bmatrix} 4.919 \angle -85.84^\circ \\ 1.727 \angle -86.44^\circ \\ 1.727 \angle -85.24^\circ \end{bmatrix} \text{ kA} \end{aligned}$$

## 9.26 Bolted line-to-line fault at bus 1.

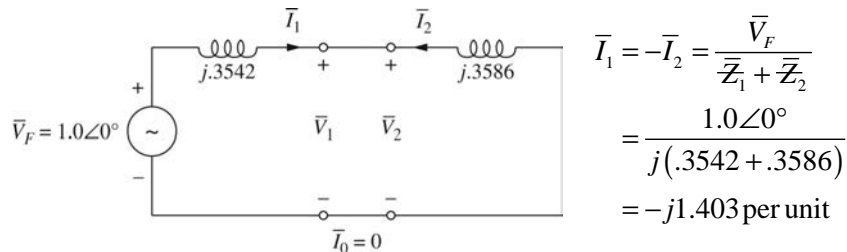

$$\begin{bmatrix} \bar{I}_A'' \\ \bar{I}_B'' \\ \bar{I}_C'' \end{bmatrix} = \begin{bmatrix} 1 & 1 & 1 \\ 1 & a^2 & a \\ 1 & a & a^2 \end{bmatrix} \begin{bmatrix} 0 \\ -j1.403 \\ +j1.403 \end{bmatrix} = \begin{bmatrix} 0 \\ 2.430\angle 180^\circ \\ 2.430\angle 0^\circ \end{bmatrix} \text{ per unit} \times 5.744$$

$$= \begin{bmatrix} 0 \\ 14.03\angle 180^\circ \\ 14.03\angle 0^\circ \end{bmatrix} \text{ kA}$$

Contributions to fault current.

**Zero sequence:**

Generator G1:  $\bar{I}_{G1-0} = 0$

Transformer T1:  $\bar{I}_{T1-0} = 0$

**Positive sequence:**

Generator G1:  $\bar{I}_{G1-1} = -j1.403 \left( \frac{.92}{.92 + .576} \right)$   
 $= -j0.8628 \text{ per unit}$

Transformer T1:  $\bar{I}_{T1-1} = -j1.403 \left( \frac{.576}{.576 + .92} \right) = -j0.5402$

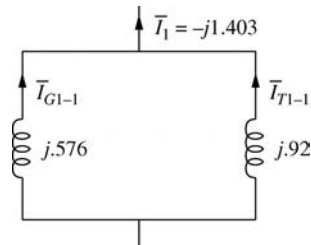

**Negative sequence:**

Generator G1:  $\bar{I}_{G1-2} = (j1.403) \left( \frac{.95}{.95 + .576} \right)$   
 $= j0.8734 \text{ per unit}$

Transformer T1:  $\bar{I}_{T1-2} = (j1.403) \left( \frac{.576}{.576 + .95} \right)$   
 $= j0.5296 \text{ per unit}$

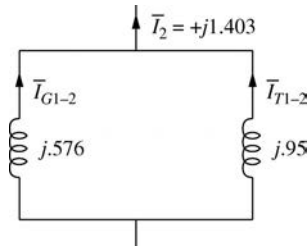

Contribution to fault from generator G1:

$$\begin{bmatrix} \bar{I}_{G1-A}'' \\ \bar{I}_{G1-B}'' \\ \bar{I}_{G1-C}'' \end{bmatrix} = \begin{bmatrix} 1 & 1 & 1 \\ 1 & a^2 & a \\ 1 & a & a^2 \end{bmatrix} \begin{bmatrix} 0 \\ -j.8628 \\ j.8734 \end{bmatrix} = \begin{bmatrix} j0.0106 \\ 1.504\angle -179.8^\circ \\ 1.504\angle -0.2^\circ \end{bmatrix} \text{ per unit} \times 5.774$$

$$= \begin{bmatrix} 0.0612\angle 90^\circ \\ 8.683\angle -179.8^\circ \\ 8.683\angle -0.2^\circ \end{bmatrix} \text{ kA}$$

Contribution to fault from transformer T1:

$$\begin{aligned} \begin{bmatrix} \bar{I}_{T1-A}'' \\ \bar{I}_{T1-B}'' \\ \bar{I}_{T1-C}'' \end{bmatrix} &= \begin{bmatrix} 1 & 1 & 1 \\ 1 & a^2 & a \\ 1 & a & a^2 \end{bmatrix} \begin{bmatrix} 0 \\ -j.5402 \\ j.5296 \end{bmatrix} = \begin{bmatrix} -j0.0106 \\ 0.9265 \angle 179.7^\circ \\ 0.9265 \angle 0.33^\circ \end{bmatrix} \text{ per unit} \times 5.774 \\ &= \begin{bmatrix} 0.0612 \angle -90^\circ \\ 5.349 \angle 179.7^\circ \\ 5.349 \angle 0.33^\circ \end{bmatrix} \text{ kA} \end{aligned}$$

**9.27 Bolted double-line to-ground fault at bus 1.**

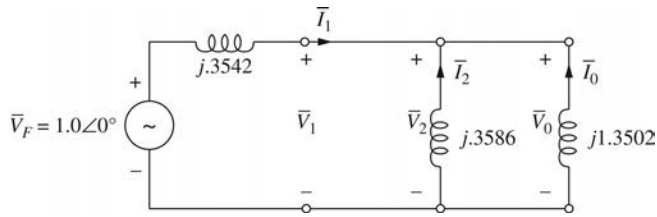

$$\begin{aligned} \bar{I}_1 &= \frac{\bar{V}_F}{\bar{Z}_1 + \bar{Z}_2 \parallel \bar{Z}_0} \\ &= \frac{1.0 \angle 0^\circ}{j(.3542 + .3586 \parallel 1.3502)} \\ &= \frac{1.0 \angle 0^\circ}{j0.6375} \\ &= -j1.569 \text{ per unit} \end{aligned}$$

$$\begin{aligned} \bar{I}_0 &= -\bar{I}_1 \left( \frac{\bar{Z}_2}{\bar{Z}_2 + \bar{Z}_0} \right) = j1.569 \left( \frac{.3586}{.3586 + 1.3502} \right) \\ &= j0.3292 \text{ per unit} \end{aligned}$$

$$\begin{aligned} \bar{I}_2 &= -\bar{I}_1 \left( \frac{\bar{Z}_0}{\bar{Z}_0 + \bar{Z}_2} \right) = j1.569 \left( \frac{1.3502}{1.3502 + .3586} \right) \\ &= j1.2394 \text{ per unit} \end{aligned}$$

$$\begin{aligned} \begin{bmatrix} \bar{I}_A'' \\ \bar{I}_B'' \\ \bar{I}_C'' \end{bmatrix} &= \begin{bmatrix} 1 & 1 & 1 \\ 1 & a^2 & a \\ 1 & a & a^2 \end{bmatrix} \begin{bmatrix} j0.3292 \\ -j1.569 \\ j1.2394 \end{bmatrix} = \begin{bmatrix} 0 \\ 2.482 \angle 168.5^\circ \\ 2.482 \angle 11.48^\circ \end{bmatrix} \text{ per unit} \times 5.774 \\ &= \begin{bmatrix} 0 \\ 14.33 \angle 168.5^\circ \\ 14.33 \angle 11.48^\circ \end{bmatrix} \text{ kA} \end{aligned}$$

Contributions to fault current.

**Zero sequence:**

Generator G1:  $\bar{I}_{G1-0} = 0$

Transformer T1:  $\bar{I}_{T1-0} = j0.3292$  per unit

**Positive sequence:**

$$\begin{aligned} \text{Generator G1: } \bar{I}_{G1-1} &= -j1.569 \left( \frac{.92}{.92 + .576} \right) \\ &= -j0.9646 \text{ per unit} \end{aligned}$$

$$\begin{aligned} \text{Transformer T1: } \bar{I}_{T1-1} &= -j1.569 \left( \frac{.576}{.576 + .92} \right) \\ &= -j0.6039 \text{ per unit} \end{aligned}$$

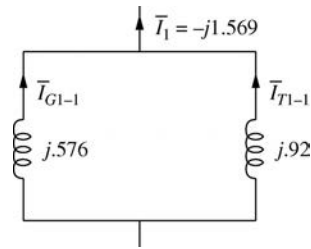

**Negative sequence:**

$$\begin{aligned} \text{Generator G1: } \bar{I}_{G1-2} &= j1.2394 \left( \frac{.95}{.95 + .576} \right) \\ &= j0.7716 \text{ per unit} \end{aligned}$$

$$\text{Transformer T1: } \bar{I}_{T1-2} = j1.2394 \left( \frac{.576}{.576 + .95} \right) = j0.4618 \text{ per unit}$$

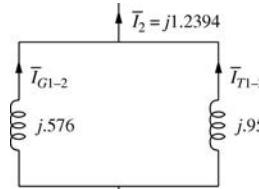

Contribution to fault from generator G1:

$$\begin{aligned} \begin{bmatrix} \bar{I}_{G1-A}'' \\ \bar{I}_{G1-B}'' \\ \bar{I}_{G1-C}'' \end{bmatrix} &= \begin{bmatrix} 1 & 1 & 1 \\ 1 & a^2 & a \\ 1 & a & a^2 \end{bmatrix} \begin{bmatrix} 0 \\ -j.9646 \\ j.7716 \end{bmatrix} = \begin{bmatrix} -j0.193 \\ 1.507 \angle 176.3^\circ \\ 1.507 \angle 3.67^\circ \end{bmatrix} \text{ per unit} \times 5.774 \\ &= \begin{bmatrix} 1.114 \angle -90^\circ \\ 8.701 \angle 176.3^\circ \\ 8.701 \angle 3.67^\circ \end{bmatrix} \text{ kA} \end{aligned}$$

Contribution to fault from transformer T1:

$$\begin{aligned} \begin{bmatrix} \bar{I}_{T1-A}'' \\ \bar{I}_{T1-B}'' \\ \bar{I}_{T1-C}'' \end{bmatrix} &= \begin{bmatrix} 1 & 1 & 1 \\ 1 & a^2 & a \\ 1 & a & a^2 \end{bmatrix} \begin{bmatrix} j0.3292 \\ -j0.6039 \\ j0.4678 \end{bmatrix} = \begin{bmatrix} j0.1931 \\ 1.010 \angle 156.8^\circ \\ 1.010 \angle 23.17^\circ \end{bmatrix} \text{ per unit} \times 5.774 \\ &= \begin{bmatrix} 1.114 \angle 90^\circ \\ 5.831 \angle 156.8^\circ \\ 5.831 \angle 23.17^\circ \end{bmatrix} \text{ kA} \end{aligned}$$

$$9.28 \quad \bar{I}_a = (\bar{I}_0 + \bar{I}_1 + \bar{I}_2) = 0 \quad \bar{I}_{a'} = (\bar{I}_{0'} + \bar{I}_{1'} + \bar{I}_{2'}) = 0$$

Also  $\bar{V}_{bb'} = \bar{V}_{cc'} = 0$ , or

$$\begin{bmatrix} V_{00'} \\ V_{11'} \\ V_{22'} \end{bmatrix} = \frac{1}{3} \begin{bmatrix} 1 & 1 & 1 \\ 1 & a & a^2 \\ 1 & a^2 & a \end{bmatrix} \begin{bmatrix} \bar{V}_{aa'} \\ 0 \\ 0 \end{bmatrix} = \begin{bmatrix} \bar{V}_{aa'} / 3 \\ \bar{V}_{aa'} / 3 \\ \bar{V}_{aa'} / 3 \end{bmatrix}$$

Which gives  $\bar{V}_{00'} = \bar{V}_{11'} = \bar{V}_{22'} = 0$

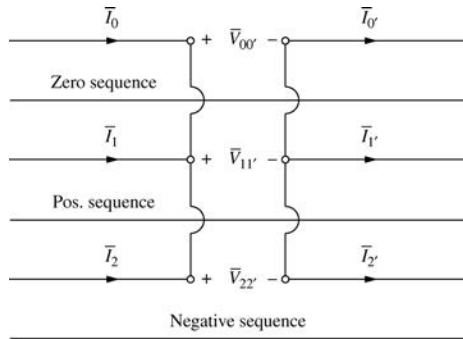

9.29  $I_b = I_c = 0$ , or

$$\begin{bmatrix} \bar{I}_0 \\ \bar{I}_1 \\ \bar{I}_2 \end{bmatrix} = \frac{1}{3} \begin{bmatrix} 1 & 1 & 1 \\ 1 & a & a^2 \\ 1 & a^2 & a \end{bmatrix} \begin{bmatrix} \bar{I}_a \\ 0 \\ 0 \end{bmatrix} = \begin{bmatrix} \bar{I}_a / 3 \\ \bar{I}_a / 3 \\ \bar{I}_a / 3 \end{bmatrix} \Rightarrow \bar{I}_0 = \bar{I}_1 = \bar{I}_2$$

Similarly  $\bar{I}_{0'} = \bar{I}_{1'} = \bar{I}_{2'}$ . Also  $\bar{V}_{aa'} = (\bar{V}_{00'} + \bar{V}_{11'} + \bar{V}_{22'}) = 0$

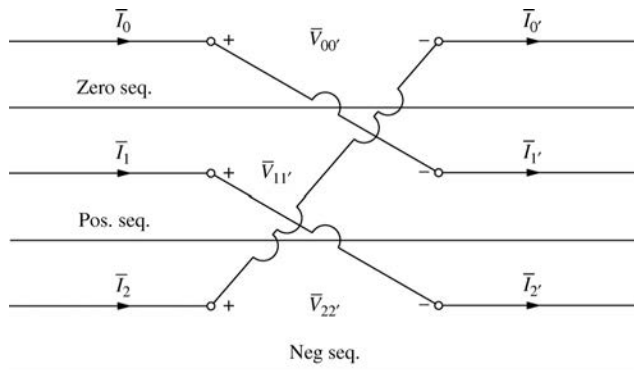

9.30 (a) For a single line-to-ground fault, the sequence networks from the solution of Pr. 9.10 are to be connected in series.

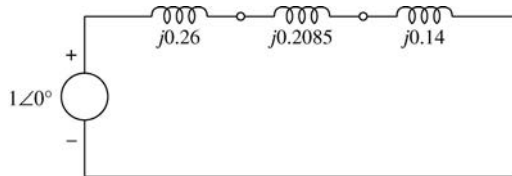

The sequence currents are given by

$$\bar{I}_0 = \bar{I}_1 = \bar{I}_2 = \frac{1}{j(0.26 + 0.2085 + 0.14)} = 1.65 \angle -90^\circ \text{ pu}$$

The subtransient fault current is

$$\bar{I}_a = 3(1.65 \angle -90^\circ) = 4.95 \angle -90^\circ \text{ pu}$$

$$\bar{I}_b = \bar{I}_c = 0$$

The sequence voltages are given by Eq. (9.1.1):

$$\bar{V}_1 = 1\angle 0^\circ - \bar{I}_1 \bar{Z}_1 = 1\angle 0^\circ - (1.65\angle -90^\circ)(0.26\angle 90^\circ) = 0.57 \text{ pu}$$

$$\bar{V}_2 = -\bar{I}_2 \bar{Z}_2 = -(1.65\angle -90^\circ)(0.2085\angle 90^\circ) = -0.34 \text{ pu}$$

$$\bar{V}_0 = -\bar{I}_0 \bar{Z}_0 = -(1.65\angle -90^\circ)(0.14\angle 90^\circ) = -0.23 \text{ pu}$$

The line-to-ground (phase) voltages at the faulted bus are

$$\begin{bmatrix} \bar{V}_{ag} \\ \bar{V}_{bg} \\ \bar{V}_{cg} \end{bmatrix} = \begin{bmatrix} 1 & 1 & 1 \\ 1 & a^2 & a \\ 1 & a & a^2 \end{bmatrix} \begin{bmatrix} -0.23 \\ 0.57 \\ -0.34 \end{bmatrix} = \begin{bmatrix} 0 \\ 0.86\angle -113.64^\circ \\ 0.86\angle 113.64^\circ \end{bmatrix} \text{ pu}$$

- (b) For a line-to-line fault through a fault impedance  $\bar{Z}_F = j0.05$ , the sequence network connection is shown below:

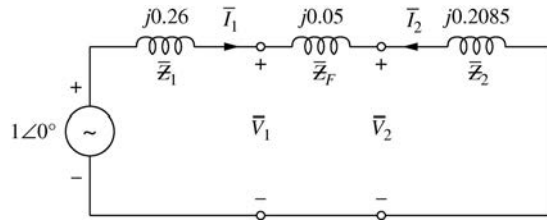

$$\bar{I}_1 = -\bar{I}_2 = \frac{1\angle 0^\circ}{0.5185\angle 90^\circ} = 1.93\angle -90^\circ \text{ pu}$$

$$\bar{I}_0 = 0$$

The phase currents are given by (Eq. 8.1.20 ~ 8.1.22)

$$\bar{I}_a = 0; \bar{I}_b = -\bar{I}_c = (a^2 - a)\bar{I}_1 = 3.34\angle -180^\circ \text{ pu}$$

The sequence voltages are

$$\begin{aligned} \bar{V}_1 &= 1\angle 0^\circ - \bar{I}_1 \bar{Z}_1 = 1\angle 0^\circ - (1.93\angle -90^\circ)(0.26\angle 90^\circ) \\ &= 0.5 \text{ pu} \end{aligned}$$

$$\begin{aligned} \bar{V}_2 &= -\bar{I}_2 \bar{Z}_2 = -(-1.93\angle -90^\circ)(0.2085\angle 90^\circ) \\ &= 0.4 \text{ pu} \end{aligned}$$

$$\bar{V}_0 = -\bar{I}_0 \bar{Z}_0 = 0$$

The phase voltages are then given by

$$\bar{V}_a = \bar{V}_1 + \bar{V}_2 + \bar{V}_0 = 0.9 \text{ pu}$$

$$\bar{V}_b = a^2 \bar{V}_1 + a \bar{V}_2 + \bar{V}_0 = 0.46\angle -169.11^\circ \text{ pu}$$

$$\bar{V}_c = a \bar{V}_1 + a^2 \bar{V}_2 + \bar{V}_0 = 0.46\angle 169.11^\circ \text{ pu}$$

$$\text{Check: } \bar{V}_b - \bar{V}_c = \bar{I}_b \bar{Z}_F = 0.17\angle -90^\circ$$



- (c) For a double line-to-ground fault with given conditions, the sequence network connection is shown below:

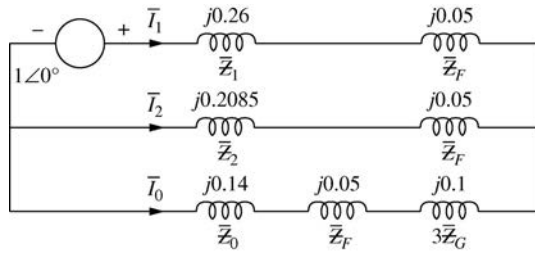

The reductions are shown below:

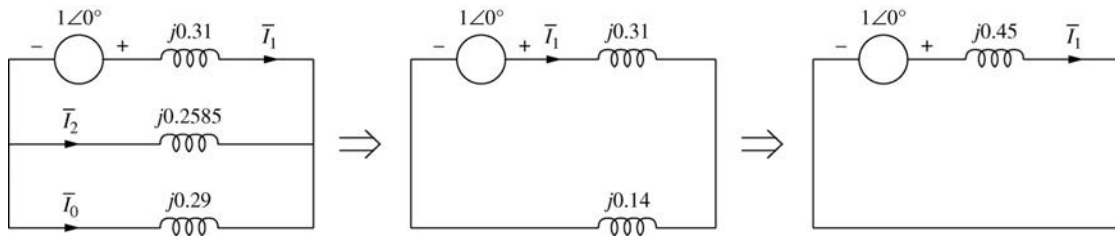

$$\therefore \bar{I}_1 = 1\angle 0^\circ / 0.45\angle 90^\circ = 2.24\angle -90^\circ$$

$$\bar{I}_2 = -\bar{I}_1 \left( \frac{0.29}{0.29 + 0.2585} \right) = -1.18\angle -90^\circ$$

$$\bar{I}_0 = -1.06\angle -90^\circ$$

The sequence voltages are given by

$$\bar{V}_1 = 1\angle 0^\circ - \bar{I}_1 \bar{Z}_1 = 1\angle 0^\circ - (2.24\angle -90^\circ)(0.26\angle 90^\circ) = 0.42$$

$$\bar{V}_2 = -\bar{I}_2 \bar{Z}_2 = -(-1.18\angle -90^\circ)(0.2085\angle 90^\circ) = 0.25$$

$$\bar{V}_0 = -\bar{I}_0 \bar{Z}_0 = -(-1.06\angle -90^\circ)(0.14\angle 90^\circ) = 0.15$$

The phase currents are calculated as

$$\bar{I}_a = 0; \bar{I}_b = a^2 \bar{I}_1 + a \bar{I}_2 + \bar{I}_0 = 3.36\angle 151.77^\circ;$$

$$\bar{I}_c = a \bar{I}_1 + a^2 \bar{I}_2 + \bar{I}_0 = 3.36\angle 28.23^\circ.$$

The neutral fault current is  $\bar{I}_b + \bar{I}_c = 3\bar{I}_0 = -3.18\angle -90^\circ$ .

The phase voltages are obtained as

$$\bar{V}_a = \bar{V}_1 + \bar{V}_2 + \bar{V}_0 = 0.82$$

$$\bar{V}_b = a^2 \bar{V}_1 + a \bar{V}_2 + \bar{V}_0 = 0.24\angle -141.49^\circ$$

$$\bar{V}_c = a \bar{V}_1 + a^2 \bar{V}_2 + \bar{V}_0 = 0.24\angle 141.49^\circ$$

- 9.31 (a) For a single line-to-ground fault at bus 3, the interconnection of the sequence networks is shown below.

(See solution of Pr. 9.12)

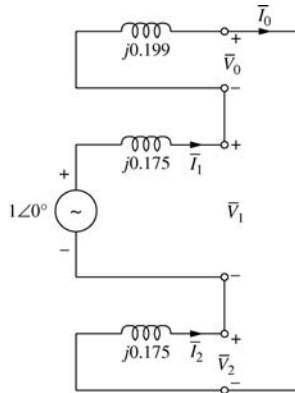

$$\bar{I}_0 = \bar{I}_1 = \bar{I}_2 = \frac{1\angle 0^\circ}{j(0.199 + 0.175 + 0.175)} = -j1.82$$

$$\begin{bmatrix} \bar{I}_a \\ \bar{I}_b \\ \bar{I}_c \end{bmatrix} = \begin{bmatrix} 1 & 1 & 1 \\ 1 & a^2 & a \\ 1 & a & a^2 \end{bmatrix} \begin{bmatrix} -j1.82 \\ -j1.82 \\ -j1.82 \end{bmatrix} = \begin{bmatrix} -j5.46 \\ 0 \\ 0 \end{bmatrix}$$

Sequence voltages are given by

$$\bar{V}_0 = -j0.199(-j1.82) = -0.362; \quad \bar{V}_1 = 1 - j0.175(-j1.82) = 0.681;$$

$$\bar{V}_2 = -j0.175(-j1.82) = -0.319$$

The phase

voltages are calculated as

$$\begin{bmatrix} \bar{V}_a \\ \bar{V}_b \\ \bar{V}_c \end{bmatrix} = \begin{bmatrix} 1 & 1 & 1 \\ 1 & a^2 & a \\ 1 & a & a^2 \end{bmatrix} \begin{bmatrix} -0.362 \\ 0.681 \\ -0.319 \end{bmatrix} = \begin{bmatrix} 0 \\ 1.022\angle 238^\circ \\ 1.022\angle 122^\circ \end{bmatrix}$$

- (b) For a line-to-line fault at bus 3, the sequence networks are interconnected as shown below:

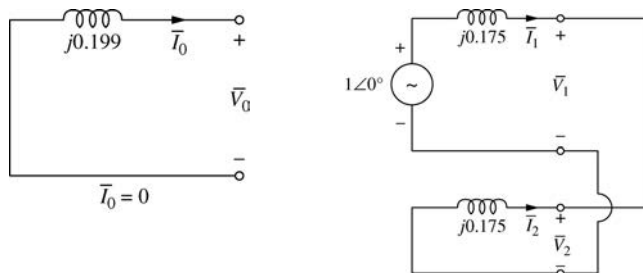

$$\bar{I}_1 = -\bar{I}_2 = \frac{1\angle 0^\circ}{j0.175 + j0.175} = -j2.86$$

Phase currents are then

$$\begin{bmatrix} \bar{I}_a \\ \bar{I}_b \\ \bar{I}_c \end{bmatrix} = \begin{bmatrix} 1 & 1 & 1 \\ 1 & a^2 & a \\ 1 & a & a^2 \end{bmatrix} \begin{bmatrix} 0 \\ -j2.86 \\ j2.86 \end{bmatrix} = \begin{bmatrix} 0 \\ -4.95 \\ 4.95 \end{bmatrix}$$

The sequence voltages are

$$\bar{V}_0 = 0; \bar{V}_1 = \bar{V}_2 = \bar{I}_1 (j0.175) = 0.5$$

Phase voltages are calculated as

$$\begin{bmatrix} \bar{V}_a \\ \bar{V}_b \\ \bar{V}_c \end{bmatrix} = \begin{bmatrix} 1 & 1 & 1 \\ 1 & a^2 & a \\ 1 & a & a^2 \end{bmatrix} \begin{bmatrix} 0 \\ 0.5 \\ 0.5 \end{bmatrix} = \begin{bmatrix} 1.0 \\ -0.5 \\ -0.5 \end{bmatrix}$$

- (c) For a double line-to-ground fault at bus 3, the sequence network interconnection is shown below:

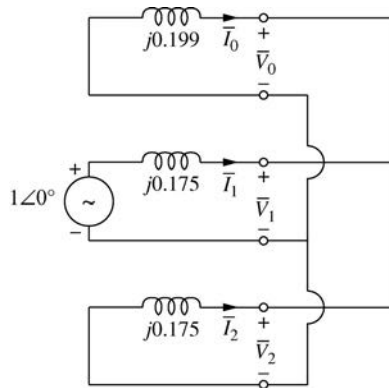

Sequence currents are calculated as

$$\bar{I}_1 = \frac{1\angle 0^\circ}{j0.175 + [j0.175(j0.199)/(j0.175 + j0.199)]} = -j3.73$$

$$\bar{I}_2 = \frac{0.199}{0.175 + 0.199} (j3.73) = j1.99$$

$$\bar{I}_0 = \frac{0.175}{0.175 + 0.199} (j3.73) = j1.75$$

Phase currents are given by

$$\begin{bmatrix} \bar{I}_a \\ \bar{I}_b \\ \bar{I}_c \end{bmatrix} = \begin{bmatrix} 1 & 1 & 1 \\ 1 & a^2 & a \\ 1 & a & a^2 \end{bmatrix} \begin{bmatrix} j1.75 \\ -j3.73 \\ j1.99 \end{bmatrix} = \begin{bmatrix} 0 \\ 5.6\angle 152.1^\circ \\ 5.6\angle 27.9^\circ \end{bmatrix}$$

The neutral fault current is  $\bar{I}_b + \bar{I}_c = 3\bar{I}_0 = j5.25$

Sequence voltages are obtained as

$$\bar{V}_0 = \bar{V}_1 = \bar{V}_2 = -(j1.75)(j0.199) = 0.348$$

Phase voltages are then

$$\begin{bmatrix} \bar{V}_a \\ \bar{V}_b \\ \bar{V}_c \end{bmatrix} = \begin{bmatrix} 1 & 1 & 1 \\ 1 & a^2 & a \\ 1 & a & a^2 \end{bmatrix} \begin{bmatrix} 0.348 \\ 0.348 \\ 0.348 \end{bmatrix} = \begin{bmatrix} 1.044 \\ 0 \\ 0 \end{bmatrix}$$

- (d) In order to compute currents and voltages at the terminals of generators G1 and G2, we need to return to the original sequence circuits in the solution of Prob. 9.12.

Generator G1 (Bus 4):

For a single line-to-ground fault, sequence network interconnection is shown below:

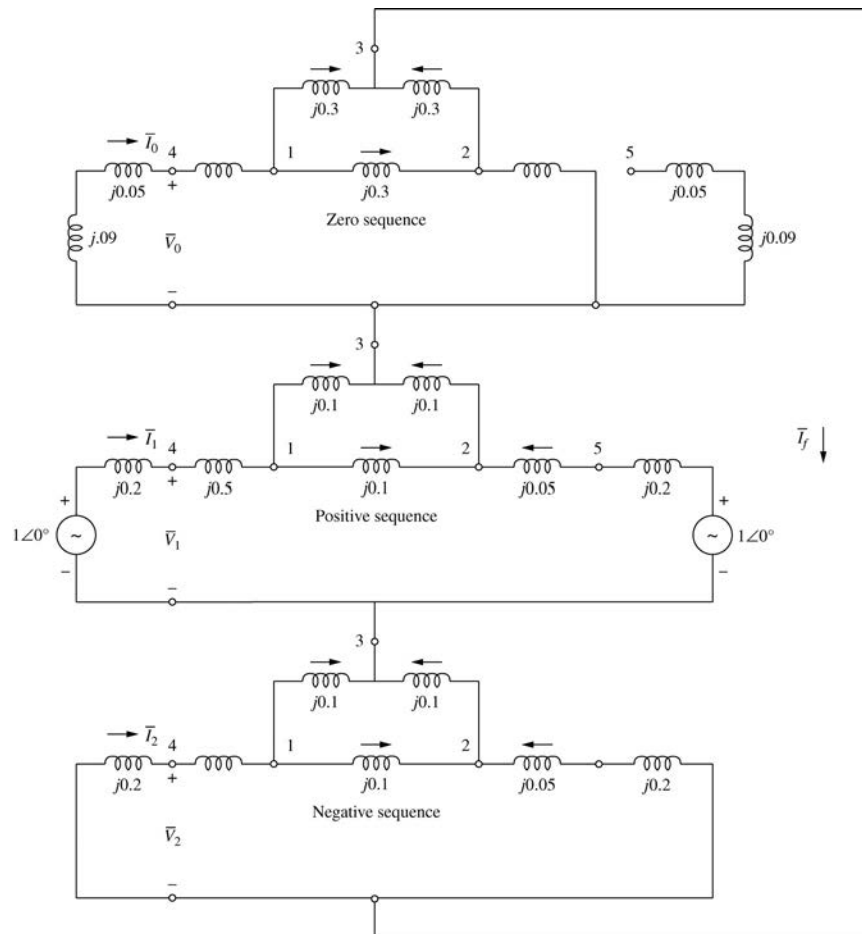

From the solution of Prob. 9.31(a),  $\bar{I}_f = -j1.82$

From the circuit above,  $\bar{I}_1 = \bar{I}_2 = \frac{1}{2}\bar{I}_f = -j0.91$

Transforming the  $\Delta$  of ( $j0.3$ ) in the zero-sequence network into an equivalent  $Y$  of ( $j0.1$ ), and using the current divider,

$$\bar{I}_0 = \frac{0.15}{0.29 + 0.15}(-j1.82) = -j0.62$$

Phase currents are then

$$\begin{bmatrix} \bar{I}_a \\ \bar{I}_b \\ \bar{I}_c \end{bmatrix} = \begin{bmatrix} 1 & 1 & 1 \\ 1 & a^2 & a \\ 1 & a & a^2 \end{bmatrix} \begin{bmatrix} -j0.62 \\ -j0.91 \\ -j0.91 \end{bmatrix} = \begin{bmatrix} 2.44 \angle -90^\circ \\ 0.29 \angle 90^\circ \\ 0.29 \angle 90^\circ \end{bmatrix}$$

Sequence voltages are calculated as

$$\bar{V}_0 = -(-j0.62)(j0.14) = -0.087; \quad \bar{V}_1 = 1 - j0.2(-j0.91) = 0.818;$$

$$\bar{V}_2 = -j0.2(-j0.91) = -0.182$$

Phase voltages are then

$$\begin{bmatrix} \bar{V}_a \\ \bar{V}_b \\ \bar{V}_c \end{bmatrix} = \begin{bmatrix} 1 & 1 & 1 \\ 1 & a^2 & a \\ 1 & a & a^2 \end{bmatrix} \begin{bmatrix} -0.087 \\ 0.818 \\ -0.182 \end{bmatrix} = \begin{bmatrix} 0.549 \angle 0^\circ \\ 0.956 \angle 245^\circ \\ 0.956 \angle 115^\circ \end{bmatrix}$$

Generator G2 (Bus 5):

From the interconnected sequence networks and solution of Prob. 9.31,

$$\bar{I}_f = -j1.182; \quad \bar{I}_1 = \bar{I}_2 = \frac{1}{2} \bar{I}_f = -j0.91; \quad \bar{I}_0 = 0$$

Recall that  $Y - \Delta$  transformer connections produce  $30^\circ$  phase shifts in sequence quantities. The HV quantities are to be shifted  $30^\circ$  ahead of the corresponding LV quantities for positive sequence, and vice versa for negative sequence. One may however neglect phase shifts. Since bus 5 is the LV side, considering phase shifts,

$$\bar{I}_1 = 0.91 \angle -90^\circ - 30^\circ = 0.91 \angle -120^\circ;$$

$$\bar{I}_2 = 0.91 \angle -90^\circ + 30^\circ = 0.91 \angle -60^\circ$$

Phase currents are then given by

$$\begin{bmatrix} \bar{I}_a \\ \bar{I}_b \\ \bar{I}_c \end{bmatrix} = \begin{bmatrix} 1 & 1 & 1 \\ 1 & a^2 & a \\ 1 & a & a^2 \end{bmatrix} \begin{bmatrix} 0 \\ 0.91 \angle -120^\circ \\ 0.91 \angle -60^\circ \end{bmatrix} = \begin{bmatrix} 1.58 \angle -90^\circ \\ 1.58 \angle +90^\circ \\ 0 \end{bmatrix}$$

Positive and negative sequence voltages are the same as on the G1 side:

$$\bar{V}_1 = 0.818; \quad \bar{V}_2 = -0.182; \quad \bar{V}_0 = 0;$$

With phase shift

$$\bar{V}_1 = 0.818 \angle -30^\circ$$

$$\bar{V}_2 = 0.182 \angle 210^\circ$$

Phase voltages are calculated as

$$\begin{bmatrix} \bar{V}_a \\ \bar{V}_b \\ \bar{V}_c \end{bmatrix} = \begin{bmatrix} 1 & 1 & 1 \\ 1 & a^2 & a \\ 1 & a & a^2 \end{bmatrix} \begin{bmatrix} 0 \\ 0.818 \angle -30^\circ \\ 0.182 \angle 210^\circ \end{bmatrix} = \begin{bmatrix} 0.744 \angle -42.2^\circ \\ 0.744 \angle 222.2^\circ \\ 1.00 \angle 90^\circ \end{bmatrix}$$

9.32 (a) Refer to the solution of Prob. 9.13.

The negative sequence network is the same as the positive sequence network without the source.

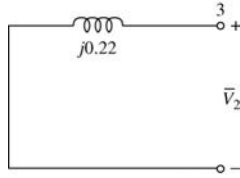

The zero-sequence network is shown below considering the transformer winding connections:

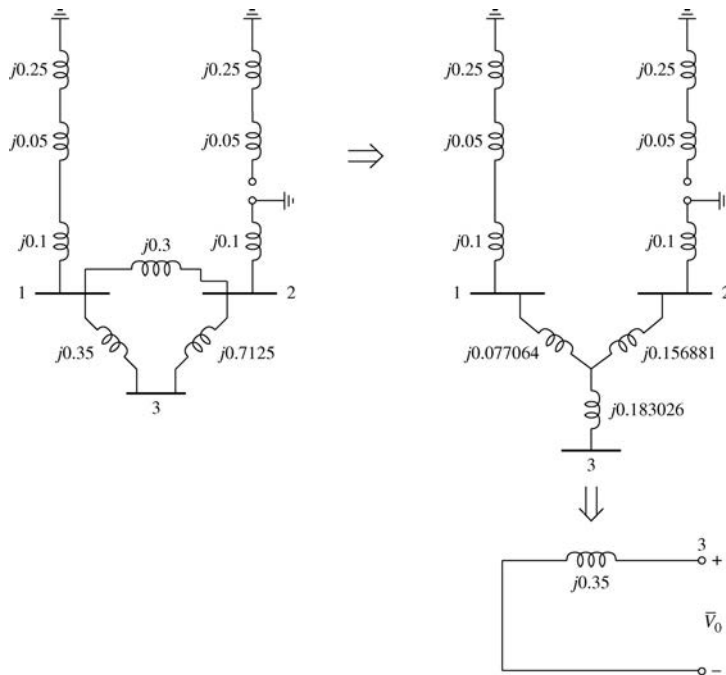

For the single line-to-ground fault

At bus 3 through a fault impedance  $\bar{Z}_F = j0.1$ ,

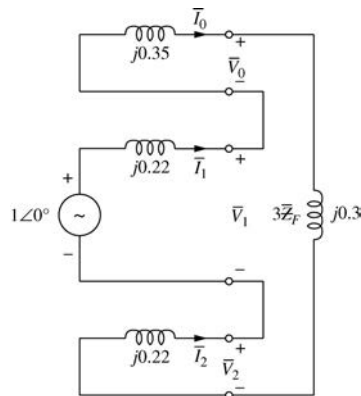

$$\bar{I}_0 = \bar{I}_1 = \bar{I}_2 = \frac{1\angle 0^\circ}{j(0.22 + 0.22 + 0.35 + 0.3)} = -j0.9174$$

Fault currents are

$$\begin{bmatrix} \bar{I}_a \\ \bar{I}_b \\ \bar{I}_c \end{bmatrix} = \begin{bmatrix} 1 & 1 & 1 \\ 1 & a^2 & a \\ 1 & a & a^2 \end{bmatrix} \begin{bmatrix} \bar{I}_0 \\ \bar{I}_1 \\ \bar{I}_2 \end{bmatrix} = \begin{bmatrix} -j2.7523 \\ 0 \\ 0 \end{bmatrix}$$

(b) For a line-to-fault at bus 3 through a fault impedance of  $j0.1$ ,

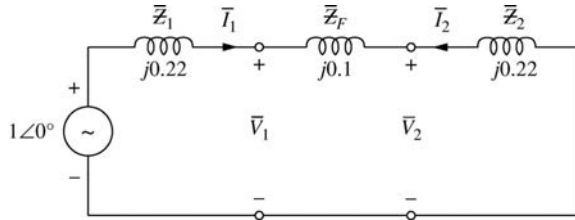

$$\bar{I}_0 = 0$$

$$\bar{I}_1 = -\bar{I}_2 = \frac{1}{j(0.22 + 0.22 + 0.1)} = -j1.8519$$

Fault currents are then

$$\begin{bmatrix} \bar{I}_a \\ \bar{I}_b \\ \bar{I}_c \end{bmatrix} = \begin{bmatrix} 1 & 1 & 1 \\ 1 & a^2 & a \\ 1 & a & a^2 \end{bmatrix} \begin{bmatrix} 0 \\ -j1.8519 \\ j1.8519 \end{bmatrix} = \begin{bmatrix} 0 \\ -3.2075 \\ 3.2075 \end{bmatrix}$$

(c) For a double line-to-ground fault at bus 3 through a common fault impedance to ground  $\bar{Z}_F = j0.1$ ,

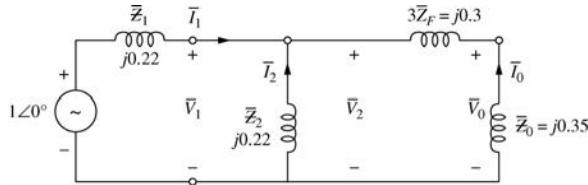

$$\bar{I}_1 = \frac{1\angle 0^\circ}{j0.22 + \frac{j0.22(j0.35 + j0.3)}{j0.22 + j0.35 + j0.3}} = -j2.6017$$

$$\bar{I}_2 = \frac{1 - (j0.22)(-j2.6017)}{j0.22} = j1.9438$$

$$\bar{I}_0 = -\frac{1 - (j0.22)(-j2.6017)}{j0.35 + j0.3} = j0.6579$$

Fault phase currents are then

$$\begin{bmatrix} \bar{I}_a \\ \bar{I}_b \\ \bar{I}_c \end{bmatrix} = \begin{bmatrix} 1 & 1 & 1 \\ 1 & a^2 & a \\ 1 & a & a^2 \end{bmatrix} \begin{bmatrix} j0.6579 \\ -j2.6017 \\ j1.9438 \end{bmatrix} = \begin{bmatrix} 0 \\ 4.058\angle 165.93^\circ \\ 4.058\angle 14.07^\circ \end{bmatrix}$$

$$\text{Neutral fault current at bus 3} = \bar{I}_b + \bar{I}_c = 3\bar{I}_0 = 1.9732\angle 90^\circ$$

9.33 Positive sequence network of the system is shown below:

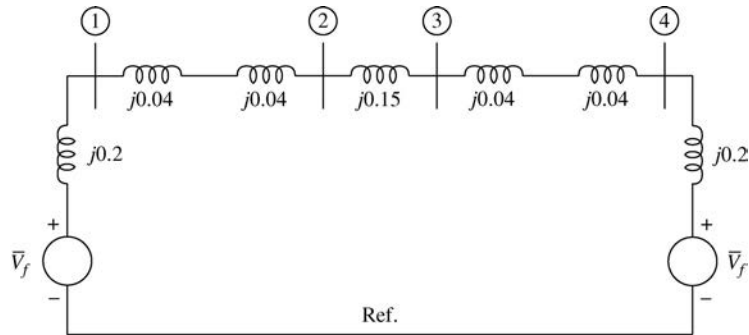

Negative sequence network is same as above without sources.

The zero sequence network is shown below:

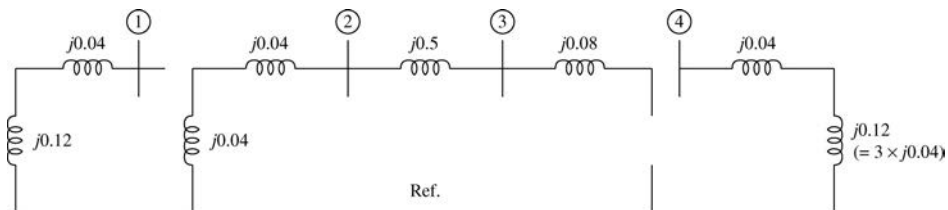

Using any one of the methods/algorithms, sequence  $\bar{Z}_{BUS}$  can be obtained.

$$\bar{Z}_{BUS1} = \bar{Z}_{BUS2} = \begin{matrix} & \begin{matrix} (1) & (2) & (3) & (4) \end{matrix} \\ \begin{matrix} (1) \\ (2) \\ (3) \\ (4) \end{matrix} & \begin{bmatrix} j0.1437 & j0.1211 & j0.0789 & j0.0563 \\ j0.1211 & j0.1696 & j0.1104 & j0.0789 \\ j0.0789 & j0.1104 & j0.1696 & j0.1211 \\ j0.0563 & j0.0789 & j0.1211 & j0.1437 \end{bmatrix} \end{matrix}$$

$$\bar{Z}_{BUS0} = \begin{matrix} & \begin{matrix} (1) & (2) & (3) & (4) \end{matrix} \\ \begin{matrix} (1) \\ (2) \\ (3) \\ (4) \end{matrix} & \begin{bmatrix} j0.16 & 0 & 0 & 0 \\ 0 & j0.08 & j0.08 & 0 \\ 0 & j0.08 & j0.58 & 0 \\ 0 & 0 & 0 & j0.16 \end{bmatrix} \end{matrix}$$

Choosing the voltage at bus 3 as  $1\angle 0^\circ$ , the prefault current in line (2) – (3) is

$$\bar{I}_{23} = \frac{P - jQ}{\bar{V}_3^*} = \frac{0.5(0.8 - j0.6)}{1\angle 0^\circ} = 0.4 - j0.3 \text{ pu}$$

Line (2) – (3) has parameters given by

$$\bar{Z}_1 = \bar{Z}_2 = j0.15; \bar{Z}_0 = j0.5$$



Denoting the open-circuit points of the line as  $p$  and  $p'$ , to simulate opening, we need to develop the Thévenin-equivalent sequence networks looking into the system between points  $p$  and  $p'$ .

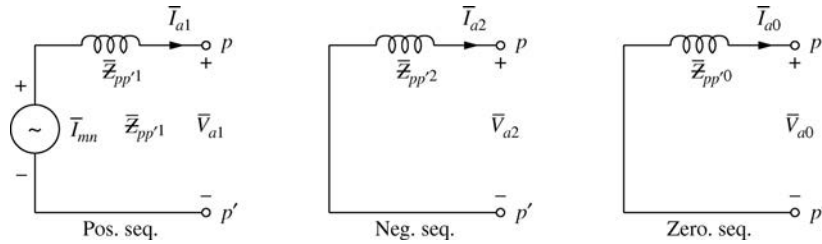

Before any conductor opens, the current  $\bar{I}_{mn}$  in phase a of the line (m) – (n) is positive sequence, given by

$$\bar{I}_{mn} = \frac{\bar{V}_m - \bar{V}_n}{\bar{Z}_1}$$

$$\bar{Z}_{pp'1} = -\frac{\bar{Z}_1^2}{\bar{Z}_{Th,mn,1} - \bar{Z}_1}; \quad \bar{Z}_{pp'2} = \frac{-\bar{Z}_2^2}{\bar{Z}_{Th,mn,2} - \bar{Z}_2}; \quad \bar{Z}_{pp'0} = \frac{-\bar{Z}_0^2}{\bar{Z}_{Th,mn,0} - \bar{Z}_0}$$

To simulate opening phase a between points  $p$  and  $p'$ , the sequence network connection is shown below:

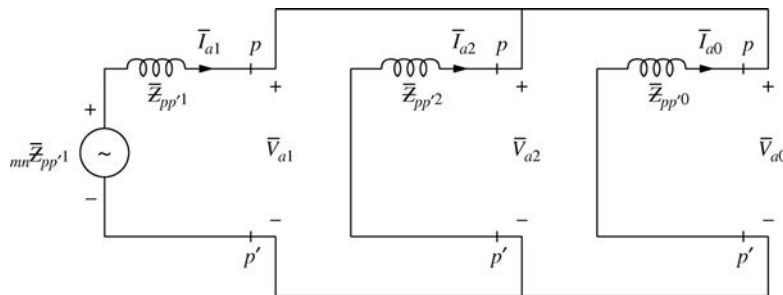

To simulate opening phases b and c between points  $p$  and  $p'$ , the sequence network connection is shown below:

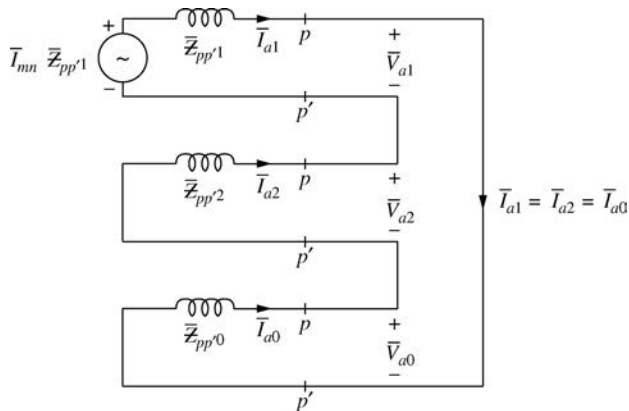

In this Problem

$$\bar{Z}_{pp'1} = \bar{Z}_{pp'2} = \frac{-\bar{Z}_1^2}{\bar{Z}_{221} + \bar{Z}_{331} - 2\bar{Z}_{231} - \bar{Z}_1} = \frac{-j(0.15)^2}{j0.1696 + j0.1696 - 2(j0.1104) - j0.15} = j0.7120$$

$$\bar{Z}_{pp'0} = \frac{-\bar{Z}_0^2}{\bar{Z}_{220} + \bar{Z}_{330} - 2\bar{Z}_{230} - \bar{Z}_0} = \frac{-(j0.5)^2}{j0.08 + j0.58 - 2(j0.08) - j0.5} = \infty$$

Note that an infinite impedance is seen looking into the zero sequence network between points  $p$  and  $p'$  of the opening, if the line from bus (2) to bus (3) is opened. Also bus (3) would be isolated from the reference by opening the connection between bus (2) and bus (3).

(a) One open conductor:

$$\bar{V}_{a0} = \bar{V}_{a1} = \bar{V}_{a2} = \bar{I}_{23} \frac{\bar{Z}_{pp'1} \bar{Z}_{pp'2}}{\bar{Z}_{pp'1} + \bar{Z}_{pp'2}} = (0.4 - j0.3) \frac{(j0.712)(j0.712)}{j(0.712 + 0.712)} = 0.1068 + j0.1424$$

$$\Delta \bar{V}_{31} = \Delta \bar{V}_{32} = \frac{\bar{Z}_{321} - \bar{Z}_{331}}{\bar{Z}_1} \bar{V}_{a1} = \frac{j0.1104 - j0.1696}{j0.15} (0.1068 + j0.1424) = -0.0422 - j0.0562$$

$$\Delta \bar{V}_{30} = \frac{\bar{Z}_{320} - \bar{Z}_{330}}{\bar{Z}_0} \bar{V}_{a0} = \frac{j0.08 - j0.58}{j0.5} (0.1068 + j0.1424) = -0.1068 - j0.1424$$

$$\Delta \bar{V}_3 = \Delta \bar{V}_{30} + \Delta \bar{V}_{31} + \Delta \bar{V}_{32} = -0.1068 - j0.1424 - 2(0.0422 + j0.0562) = -0.1912 - j0.2548$$

Since the prefault voltage at bus (3) is  $1\angle 0^\circ$ , the new voltage at bus (3) is

$$\bar{V}_3 + \Delta \bar{V}_3 = (1 + j0) + (-0.1912 - j0.2548) = 0.8088 - j0.2548 = 0.848\angle -17.5^\circ \text{ pu}$$

(b) Two open conductors:

Inserting an infinite impedance of the zero sequence network in series between points  $p$  and  $p'$  of the positive-sequence network causes an open circuit in the latter. No power transfer can occur in the system. Obviously, power cannot be transferred by only one phase conductor of the transmission line, since the zero sequence network offers no return path for current.

9.34

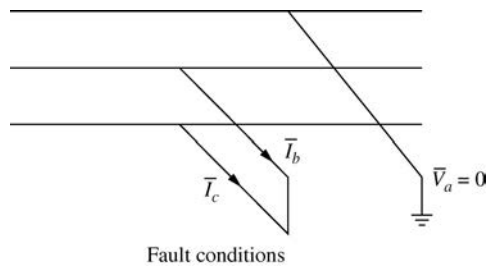

$$\bar{V}_a = 0; \bar{V}_b = \bar{V}_c; \bar{I}_b + \bar{I}_c = 0$$

Sequence currents are given by

$$\bar{I}_0 = \frac{1}{3}\bar{I}_a; \bar{I}_1 = \frac{1}{3}[\bar{I}_a + (a - a^2)\bar{I}_b]; \bar{I}_2 = \frac{1}{3}[\bar{I}_a + (a^2 - a)\bar{I}_b]$$

One can conclude that  $\bar{I}_1 + \bar{I}_2 = 2\bar{I}_0$

Sequence network connection to satisfy the above:

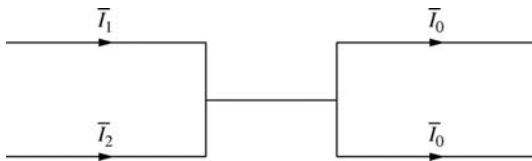

Sequence voltages are obtained below:

$$\bar{V}_1 = \frac{1}{3}[(a + a^2)\bar{V}_b] = -\frac{1}{3}\bar{V}_b$$

$$\bar{V}_2 = \frac{1}{3}[(a + a^2)\bar{V}_b] = -\frac{1}{3}\bar{V}_b$$

$$\bar{V}_0 = \frac{1}{3}(2\bar{V}_b) = \frac{2}{3}\bar{V}_b$$

Thus  $\bar{V}_1 = \bar{V}_2$  and  $\bar{V}_1 + \bar{V}_2 + \bar{V}_0 = 0$

The sequence network interconnection is then given by:

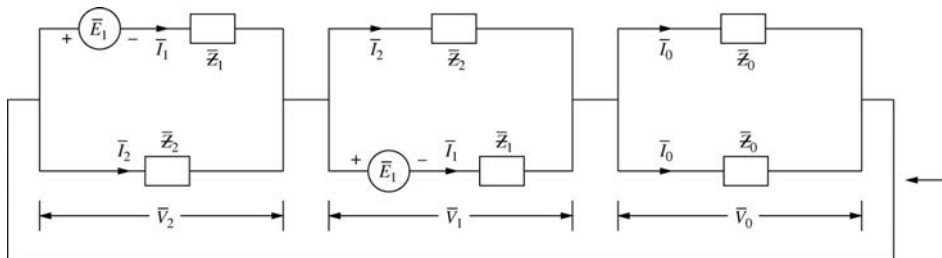

9.35 (a) Following Ex. 9.2 of the text:

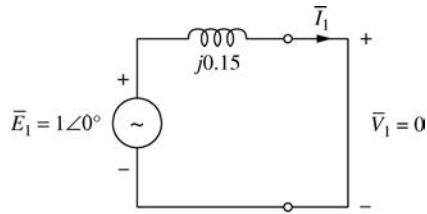

$$\bar{I}_1 = \frac{1\angle 0^\circ}{j0.15} = -j6.67; \bar{I}_2 = 0; \bar{I}_0 = 0$$

$$\bar{V}_0 = \bar{V}_1 = \bar{V}_2 = 0$$

$$\bar{V}_a = 6.67\angle -90^\circ; \bar{V}_b = 6.67\angle 150^\circ; \bar{V}_c = 6.67\angle 30^\circ \leftarrow$$

$$\bar{V}_a = \bar{V}_b = \bar{V}_c = 0 \text{ (Bolted 3-phase fault)} \leftarrow$$

(b) Following Ex. 9.3 of the text

$$\bar{I}_0 = \bar{I}_1 = \bar{I}_2 = \frac{1\angle 0^\circ}{j(0.15 + 0.15 + 0.2)} = -j2$$

$$\bar{I}_a = 3(-j2) = -j6; \bar{I}_b = \bar{I}_c = 0 \leftarrow$$

$$\begin{bmatrix} \bar{V}_0 \\ \bar{V}_1 \\ \bar{V}_2 \end{bmatrix} = \begin{bmatrix} 0 \\ 1\angle 0^\circ \\ 0 \end{bmatrix} - \begin{bmatrix} j0.2 & 0 & 0 \\ 0 & j0.15 & 0 \\ 0 & 0 & j0.15 \end{bmatrix} \begin{bmatrix} -j2 \\ -j2 \\ -j2 \end{bmatrix}$$

$$= \begin{bmatrix} -0.4 \\ 0.7 \\ -0.3 \end{bmatrix}$$

$$\begin{bmatrix} \bar{V}_a \\ \bar{V}_b \\ \bar{V}_c \end{bmatrix} = \begin{bmatrix} 1 & 1 & 1 \\ 1 & a^2 & a \\ 1 & a & a^2 \end{bmatrix} \begin{bmatrix} -0.4 \\ 0.7 \\ -0.3 \end{bmatrix} = \begin{bmatrix} 0 \\ 1.11\angle 233^\circ \\ 1.11\angle 125^\circ \end{bmatrix} \leftarrow$$

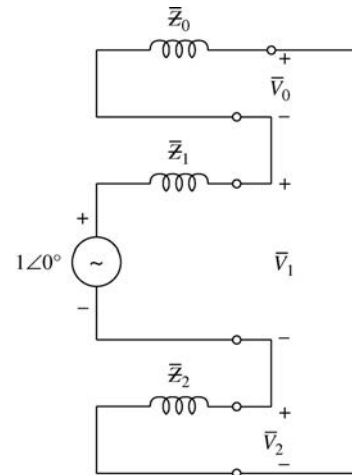

(c) Following Ex. 9.4 of the text:

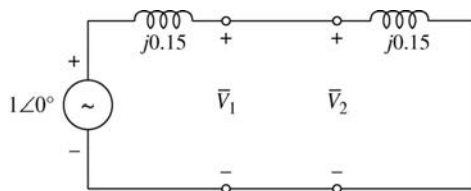

$$\bar{I}_1 = -\bar{I}_2 = \frac{1\angle 0^\circ}{j(0.15 + 0.15)} = -j3.333$$

$$\bar{I}_0 = 0$$

$$\left. \begin{aligned} \bar{I}_b &= (-j\sqrt{3})(-j3.333) = -5.773 \\ \bar{I}_c &= 5.773; \bar{I}_a = 0 \end{aligned} \right\} \leftarrow$$

$$\bar{V}_1 = \bar{V}_2 = \bar{I}_1(j0.15) = 0.5; \bar{V}_0 = 0$$

$$\begin{bmatrix} \bar{V}_a \\ \bar{V}_b \\ \bar{V}_c \end{bmatrix} = \begin{bmatrix} 1 & 1 & 1 \\ 1 & a^2 & a \\ 1 & a & a^2 \end{bmatrix} \begin{bmatrix} 0 \\ 0.5 \\ 0.5 \end{bmatrix} = \begin{bmatrix} 1.0 \\ -0.5 \\ -0.5 \end{bmatrix} \leftarrow$$

(d) Following Ex. 9.5 of the text:

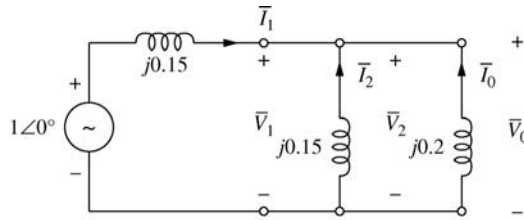

$$\bar{I}_1 = \frac{1\angle 0^\circ}{j\left[0.15 + \frac{0.15 \times 0.2}{0.15 + 0.2}\right]} = -j4.242$$

$$\bar{I}_2 = (j4.242) \left( \frac{0.2}{0.2 + 0.15} \right) = j2.424$$

$$\bar{I}_0 = (j4.242) \left( \frac{0.15}{0.2 + 0.15} \right) = j1.818$$

$$\begin{bmatrix} \bar{I}_a \\ \bar{I}_b \\ \bar{I}_c \end{bmatrix} = \begin{bmatrix} 1 & 1 & 1 \\ 1 & a^2 & a \\ 1 & a & a^2 \end{bmatrix} \begin{bmatrix} j1.818 \\ -j4.242 \\ j2.424 \end{bmatrix} = \begin{bmatrix} 0 \\ 5.5\angle 118.2^\circ \\ 5.5\angle 61.8^\circ \end{bmatrix} \leftarrow$$

$$\bar{V}_0 = \bar{V}_1 = \bar{V}_2 = -j1.818(j0.2) = 0.364$$

$$\begin{bmatrix} \bar{V}_a \\ \bar{V}_b \\ \bar{V}_c \end{bmatrix} = \begin{bmatrix} 1 & 1 & 1 \\ 1 & a^2 & a \\ 1 & a & a^2 \end{bmatrix} \begin{bmatrix} 0.364 \\ 0.364 \\ 0.364 \end{bmatrix} = \begin{bmatrix} 1.092 \\ 0 \\ 0 \end{bmatrix} \leftarrow$$

Worst fault: 3-phase fault with a fault current of 6.67 pu ←

**9.36** The positive-sequence per-phase circuit is shown below:

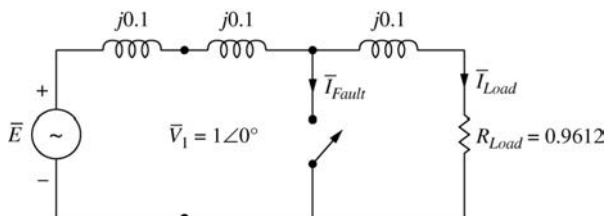

$$\bar{V}_3 \bar{I}_{LOAD}^* = 1; \bar{I}_{LOAD} = 1.02\angle -10^\circ \text{ prior to the fault}$$

$$\bar{E} = 1\angle 0^\circ + j0.1(1.02\angle -10^\circ) = 1.023\angle 5.64^\circ$$

With a short from bus 2 to ground, i.e. with switch closed,

$$\bar{I}_{FAULT} = \frac{1.023 \angle 5.64^\circ}{j0.2} = 5.115 \angle -84.36^\circ \leftarrow$$

**9.37** (a)  $\bar{E}_1 = 1 \angle 0^\circ + (1 \angle 0^\circ)(j0.1) = 1 + j0.1$

$$\bar{E}_2 = 1 \angle 0^\circ - (1 \angle 0^\circ)(j0.15) = 1 - j0.15$$

With switch closed,

$$\bar{I}_1 = \frac{\bar{E}_1}{j0.1} = \frac{1 + j0.1}{j0.1} = 1 - j10$$

$$\bar{I}_2 = \frac{\bar{E}_2}{j0.15} = \frac{1 - j0.15}{j0.15} = -1 - j6.67$$

$$\bar{I} = \bar{I}_1 + \bar{I}_2 = -j16.67 \leftarrow$$

(b) Superposition:

Ignoring prefault currents

$$\bar{E}_1 = \bar{E}_2 = 1 \angle 0^\circ$$

$$\bar{I}_1 = \frac{1 \angle 0^\circ}{j0.1} = -j10; \quad \bar{I}_2 = \frac{1 \angle 0^\circ}{j0.15} = -j6.67$$

$$\bar{I} = \bar{I}_1 + \bar{I}_2 = -j16.67$$

Now load currents are superimposed:

$$\bar{I}_1 = \bar{I}_{1FAULT} + \bar{I}_{1LOAD} = -j10 + 1 = 1 - j10$$

$$\bar{I}_2 = \bar{I}_{2FAULT} + \bar{I}_{2LOAD} = -j6.67 + (-1) = -1 - j6.67$$

$$\bar{I} = \bar{I}_{FAULT} + \bar{I}_{LOAD} = -j16.67 \leftarrow$$

Same as in part (a)  $\leftarrow$

**9.38**  $\bar{I}_{1-1} = \frac{\bar{V}_F}{\bar{Z}_{11-1}} = \frac{1.0 \angle 0^\circ}{j0.12} = -j8.333$  per unit

$$\begin{bmatrix} \bar{I}_{1a}'' \\ \bar{I}_{1b}'' \\ \bar{I}_{1c}'' \end{bmatrix} = \begin{bmatrix} 1 & 1 & 1 \\ 1 & a^2 & a \\ 1 & a & a^2 \end{bmatrix} \begin{bmatrix} 0 \\ 8.333 \angle -90^\circ \\ 0 \end{bmatrix} = \begin{bmatrix} 8.333 \angle -90^\circ \\ 8.333 \angle 150^\circ \\ 8.333 \angle 30^\circ \end{bmatrix} \text{ per unit}$$

Using Eq (9.5.9) with  $k = 2$  and  $n = 1$ :

$$\begin{bmatrix} \bar{V}_{2-0} \\ \bar{V}_{2-1} \\ \bar{V}_{2-2} \end{bmatrix} = \begin{bmatrix} 0 \\ 1 \angle 0^\circ \\ 0 \end{bmatrix} - \begin{bmatrix} 0 & 0 & 0 \\ 0 & j0.08 & 0 \\ 0 & 0 & j0.08 \end{bmatrix} \begin{bmatrix} 0 \\ -j8.333 \\ 0 \end{bmatrix} = \begin{bmatrix} 0 \\ 0.3333 \\ 0 \end{bmatrix} \text{ per unit}$$

$$\begin{bmatrix} \bar{V}_{2ag} \\ \bar{V}_{2bg} \\ \bar{V}_{2cg} \end{bmatrix} = \begin{bmatrix} 1 & 1 & 1 \\ 1 & a^2 & a \\ 1 & a & a^2 \end{bmatrix} \begin{bmatrix} 0 \\ 0.3333 \\ 0 \end{bmatrix} = \begin{bmatrix} 0.3333 \angle 0^\circ \\ 0.3333 \angle 240^\circ \\ 0.3333 \angle 120^\circ \end{bmatrix} \text{ per unit}$$

$$\begin{aligned}
 9.39 \quad \bar{I}_{1-0} = \bar{I}_{1-1} = \bar{I}_{1-2} &= \frac{\bar{V}_F}{\bar{Z}_{11-0} + \bar{Z}_{11-1} + \bar{Z}_{11-2}} = \frac{1.0 \angle 0^\circ}{j(0.10 + 0.12 + 0.12)} \\
 &= -j2.941 \text{ per unit}
 \end{aligned}$$

$$\begin{bmatrix} \bar{I}_{1a}'' \\ \bar{I}_{1b}'' \\ \bar{I}_{1c}'' \end{bmatrix} = \begin{bmatrix} 1 & 1 & 1 \\ 1 & a^2 & a \\ 1 & a & a^2 \end{bmatrix} \begin{bmatrix} -j2.941 \\ -j2.941 \\ -j2.941 \end{bmatrix} = \begin{bmatrix} -j8.824 \\ 0 \\ 0 \end{bmatrix} \text{ per unit}$$

Using Eq (9.5.9) with  $k = 2$  and  $n = 1$ :

$$\begin{bmatrix} \bar{V}_{2-0} \\ \bar{V}_{2-1} \\ \bar{V}_{2-2} \end{bmatrix} = \begin{bmatrix} 0 \\ 1 \angle 0^\circ \\ 0 \end{bmatrix} - \begin{bmatrix} 0 & 0 & 0 \\ 0 & j0.08 & 0 \\ 0 & 0 & j0.08 \end{bmatrix} \begin{bmatrix} -j2.941 \\ -j2.941 \\ -j2.941 \end{bmatrix} = \begin{bmatrix} 0 \\ 0.7647 \\ -0.2353 \end{bmatrix} \text{ per unit}$$

$$\begin{bmatrix} \bar{V}_{2ag} \\ \bar{V}_{2bg} \\ \bar{V}_{2cg} \end{bmatrix} = \begin{bmatrix} 1 & 1 & 1 \\ 1 & a^2 & a \\ 1 & a & a^2 \end{bmatrix} \begin{bmatrix} 0 \\ .7647 \\ -.2353 \end{bmatrix} = \begin{bmatrix} 0.5294 \angle 0^\circ \\ 0.9056 \angle 253.0^\circ \\ 0.9056 \angle 107.0^\circ \end{bmatrix} \text{ per unit}$$

$$\begin{aligned}
 9.40 \quad \bar{I}_{1-1} = -\bar{I}_{1-2} &= \frac{\bar{V}_F}{\bar{Z}_{11-1} + \bar{Z}_{11-2}} = \frac{1.0 \angle 0^\circ}{j(.12 + .12)} \\
 &= -j4.167 \text{ per unit}
 \end{aligned}$$

$$\begin{bmatrix} \bar{I}_{1a}'' \\ \bar{I}_{1b}'' \\ \bar{I}_{1c}'' \end{bmatrix} = \begin{bmatrix} 1 & 1 & 1 \\ 1 & a^2 & a \\ 1 & a & a^2 \end{bmatrix} \begin{bmatrix} 0 \\ -j4.167 \\ +j4.167 \end{bmatrix} = \begin{bmatrix} 0 \\ 7.217 \angle 180^\circ \\ 7.217 \angle 0^\circ \end{bmatrix} \text{ per unit}$$

Using Eq (9.5.9) with  $k = 2$  and  $n = 1$ :

$$\begin{bmatrix} \bar{V}_{2-0} \\ \bar{V}_{2-1} \\ \bar{V}_{2-2} \end{bmatrix} = \begin{bmatrix} 0 \\ 1 \angle 0^\circ \\ 0 \end{bmatrix} - \begin{bmatrix} 0 & 0 & 0 \\ 0 & j0.08 & 0 \\ 0 & 0 & j0.08 \end{bmatrix} \begin{bmatrix} 0 \\ -j4.167 \\ j4.167 \end{bmatrix} = \begin{bmatrix} 0 \\ 0.6667 \\ 0.3333 \end{bmatrix} \text{ per unit}$$

$$\begin{bmatrix} \bar{V}_{2ag} \\ \bar{V}_{2bg} \\ \bar{V}_{2cg} \end{bmatrix} = \begin{bmatrix} 1 & 1 & 1 \\ 1 & a^2 & a \\ 1 & a & a^2 \end{bmatrix} \begin{bmatrix} 0 \\ .6667 \\ .3333 \end{bmatrix} = \begin{bmatrix} 1.0 \\ 0.5774 \angle 210^\circ \\ 0.5774 \angle 150^\circ \end{bmatrix} \text{ per unit}$$

$$\begin{aligned}
 9.41 \quad \bar{I}_{1-1} &= \frac{\bar{V}_F}{\bar{Z}_{11-1} + \bar{Z}_{11-2} // \bar{Z}_{11-0}} = \frac{1.0 \angle 0^\circ}{j(0.12 + 0.12 // 0.10)} \\
 &= -j5.729 \text{ per unit}
 \end{aligned}$$

$$\bar{I}_{1-2} = (+j5.729) \left( \frac{0.10}{0.22} \right) = j2.604 \text{ per unit}$$

$$\bar{I}_{1-0} = (+j5.729) \left( \frac{0.12}{0.22} \right) = j3.125 \text{ per unit}$$

$$\begin{bmatrix} \bar{I}_{1a}'' \\ \bar{I}_{1b}'' \\ \bar{I}_{1c}'' \end{bmatrix} = \begin{bmatrix} 1 & 1 & 1 \\ 1 & a^2 & a \\ 1 & a & a^2 \end{bmatrix} \begin{bmatrix} j3.125 \\ -j5.729 \\ +j2.604 \end{bmatrix} = \begin{bmatrix} 0 \\ 8.605 \angle 147.0^\circ \\ 8.605 \angle 33.0^\circ \end{bmatrix} \text{ per unit}$$

Using Eq (9.5.9) with  $k = 2$  and  $n = 1$ :

$$\begin{bmatrix} \bar{V}_{2-0} \\ \bar{V}_{2-1} \\ \bar{V}_{2-2} \end{bmatrix} = \begin{bmatrix} 0 \\ 1.0 \angle 0^\circ \\ 0 \end{bmatrix} - \begin{bmatrix} 0 & 0 & 0 \\ 0 & j.08 & 0 \\ 0 & 0 & j.08 \end{bmatrix} \begin{bmatrix} j3.125 \\ -j5.729 \\ j2.604 \end{bmatrix} = \begin{bmatrix} 0 \\ 0.5417 \\ 0.2083 \end{bmatrix} \text{ per unit}$$

$$\begin{bmatrix} \bar{V}_{2ag} \\ \bar{V}_{2bg} \\ \bar{V}_{2cg} \end{bmatrix} = \begin{bmatrix} 1 & 1 & 1 \\ 1 & a^2 & a \\ 1 & a & a^2 \end{bmatrix} \begin{bmatrix} 0 \\ .5417 \\ .2083 \end{bmatrix} = \begin{bmatrix} 0.750 \\ 0.4733 \angle 217.6^\circ \\ 0.4733 \angle 142.4^\circ \end{bmatrix} \text{ per unit}$$

[Note: For details on “formation of  $\bar{Z}_{bus}$  one step at a time”, please refer to edition 1 or 2 of the text.]

**9.42** (a) Zero sequence bus impedance matrix:

Step (1): Add  $\bar{Z}_b = j0.10$  from the reference to bus 1 (type 1)

$$\bar{Z}_{bus-0} = j0.10 \text{ per unit}$$

Step (2): Add  $\bar{Z}_b = j0.2563$  from bus 1 to bus 2 (type 2)

$$\bar{Z}_{bus-0} = j \begin{bmatrix} 0.10 & 0.10 \\ 0.10 & 0.3563 \end{bmatrix} \text{ per unit}$$

Step (3): Add  $\bar{Z}_b = j0.10$  from the reference to bus 2 (type 3)

$$\bar{Z}_{bus-0} = j \begin{bmatrix} 0.1 & 0.1 \\ 0.1 & 0.3563 \end{bmatrix} - \frac{j}{.4563} \begin{bmatrix} .10 \\ .3563 \end{bmatrix} [ .10.3563 ] = j \begin{bmatrix} .07808 & .02192 \\ .02192 & .07808 \end{bmatrix}$$

Step (4): Add  $\bar{Z}_b = j0.1709$  from bus 2 to bus 3 (type 2)

$$\bar{Z}_{bus-0} = j \begin{bmatrix} 0.07808 & 0.02192 & 0.02192 \\ 0.02192 & 0.07808 & 0.07808 \\ 0.02192 & 0.07808 & 0.24898 \end{bmatrix} \text{ per unit}$$

Step (5): Add  $\bar{Z}_b = j0.1709$  from bus 1 to bus 3 (type 4)

$$\bar{Z}_{bus-0} = j \begin{bmatrix} .07808^+ & .02192 & .02192^- \\ .02192 & .07808 & .07808 \\ .02192 & .07808 & .24898 \end{bmatrix} - \frac{j}{.45412} \begin{bmatrix} .05616 \\ -.05616 \\ -.22706 \end{bmatrix} [ .05616 \quad -.05616 \quad -.22706 ]$$

$$\bar{Z}_{bus-0} = j \begin{bmatrix} 0.07114 & 0.02887 & 0.05 \\ 0.02887 & 0.07114 & 0.05 \\ 0.05 & 0.05 & 0.13545 \end{bmatrix} \text{ per unit}$$



Positive sequence bus impedance matrix:

Step (1): Add  $\bar{Z}_b = j0.28$  from the reference to bus 1 (type 1)

$$\bar{Z}_{bus-1} = j[0.28] \text{ per unit}$$

Step (2): Add  $\bar{Z}_b = j0.08544$  from bus 1 to bus 2 (type 2)

$$\bar{Z}_{bus-1} = j \left[ \begin{array}{c|c} .28 & .28 \\ \hline .28 & .36544 \end{array} \right] \text{ per unit}$$

Step (3): Add  $\bar{Z}_b = j0.3$  from the reference to bus 2 (type 3)

$$\bar{Z}_{bus-1} = j \left[ \begin{array}{cc} .28 & .28 \\ .28 & .36544 \end{array} \right] - \frac{j}{.66544} \left[ \begin{array}{c} .28 \\ .36544 \end{array} \right] \left[ .28 \quad .36544 \right] = j \left[ \begin{array}{c|c} .16218 & .12623 \\ \hline .12623 & .16475 \end{array} \right]$$

Step (4): Add  $\bar{Z}_b = j0.06835$  from bus 2 to bus 3 (type 2)

$$\bar{Z}_{bus-1} = j \left[ \begin{array}{ccc} 0.16218 & 0.12623 & 0.12623 \\ 0.12623 & 0.16475 & 0.16475 \\ 0.12623 & 0.16475 & 0.2331 \end{array} \right] \text{ per unit}$$

Step (5): Add  $\bar{Z}_b = j0.06835$  from bus 1 to bus 3 (type 4)

$$\bar{Z}_{bus-1} = j \left[ \begin{array}{ccc} .16218 & .12623 & .12623 \\ .12623 & .16475 & .16475 \\ .12623 & .16475 & .2331 \end{array} \right] - \frac{j}{.21117} \left[ \begin{array}{c} +.03595 \\ -.03852 \\ -.10687 \end{array} \right] \left[ .03595 \quad -.03852 \quad -.10687 \right]$$

$$\bar{Z}_{bus-1} = j \left[ \begin{array}{ccc} .15606 & .13279 & .14442 \\ .13279 & .15772 & .14526 \\ .14442 & .14526 & .17901 \end{array} \right] \text{ per unit}$$

Step (6): Add  $\bar{Z}_b = j(.4853 // .4939) = j0.2448$  from the reference to bus 3 (type 3)

$$\bar{Z}_{bus-1} = j \left[ \begin{array}{ccc} .15606 & .13279 & .14442 \\ .13279 & .15772 & .14526 \\ .14442 & .14526 & .17901 \end{array} \right] - \frac{j}{.42379} \left[ \begin{array}{c} .14442 \\ .14526 \\ .17901 \end{array} \right] \left[ .14442 \quad .14526 \quad .17901 \right]$$

$$\bar{Z}_{bus-1} = j \left[ \begin{array}{ccc} 0.1068 & 0.08329 & 0.08342 \\ 0.08329 & 0.1079 & 0.08390 \\ 0.08342 & 0.08390 & 0.10340 \end{array} \right] \text{ per unit}$$

Negative sequence bus impedance matrix:

Steps (1) – (5) are the same as for  $\bar{Z}_{bus-1}$ .

Step (6): Add  $\bar{Z}_b = j(.5981//.4939) = j0.2705$  from the reference bus to bus 3 (type 3)

$$\bar{Z}_{bus-2} = j \begin{bmatrix} .15606 & .13279 & .14442 \\ .13279 & .15772 & .14526 \\ .14442 & .14526 & .17901 \end{bmatrix} - \frac{j}{.44951} \begin{bmatrix} .14442 \\ .14526 \\ .17901 \end{bmatrix} \begin{bmatrix} .14442 & .14526 & .17901 \end{bmatrix}$$

$$\bar{Z}_{bus-2} = j \begin{bmatrix} 0.1097 & 0.08612 & 0.08691 \\ 0.08612 & 0.11078 & 0.08741 \\ 0.08691 & 0.08741 & 0.10772 \end{bmatrix} \text{ per unit}$$

(b) From the results of Problem 9.42(a),  $\bar{Z}_{1-0} = j0.07114$ ,  $\bar{Z}_{1-1} = j0.1068$ , and  $\bar{Z}_{1-2} = j0.1097$  per unit are the same as the Thevenin equivalent sequence impedances at bus 1, as calculated in Problem 9.2. Therefore, the fault currents calculated from the sequence impedance matrices will be the same as those calculated in Problems 9.3 and 9.14–9.17.

**9.43**  $I_{1-1} = \frac{\bar{V}_F}{\bar{Z}_{1-1}} = \frac{1.0 \angle 0^\circ}{j0.20} = 5.0 \angle -90^\circ$  per unit

$$\begin{bmatrix} \bar{I}_{1a}'' \\ \bar{I}_{1b}'' \\ \bar{I}_{1c}'' \end{bmatrix} = \begin{bmatrix} 1 & 1 & 1 \\ 1 & a^2 & a \\ 1 & a & a^2 \end{bmatrix} \begin{bmatrix} 0 \\ 5 \angle -90^\circ \\ 0 \end{bmatrix} = \begin{bmatrix} 5 \angle -90^\circ \\ 5 \angle 150^\circ \\ 5 \angle 30^\circ \end{bmatrix} \text{ per unit}$$

Using (9.5.9) with  $k = 2$  and  $n = 1$ :

$$\begin{bmatrix} \bar{V}_{2-0} \\ \bar{V}_{2-1} \\ \bar{V}_{2-2} \end{bmatrix} = \begin{bmatrix} 0 \\ 1.0 \angle 0^\circ \\ 0 \end{bmatrix} - \begin{bmatrix} 0 & 0 & 0 \\ 0 & j0.10 & 0 \\ 0 & 0 & j0.10 \end{bmatrix} \begin{bmatrix} 0 \\ -j5.0 \\ 0 \end{bmatrix} = \begin{bmatrix} 0 \\ 0.50 \\ 0 \end{bmatrix} \text{ per unit}$$

$$\begin{bmatrix} \bar{V}_{2ag} \\ \bar{V}_{1bg} \\ \bar{V}_{2cg} \end{bmatrix} = \begin{bmatrix} 1 & 1 & 1 \\ 1 & a^2 & a \\ 1 & a & a^2 \end{bmatrix} \begin{bmatrix} 0 \\ 0.50 \\ 0 \end{bmatrix} = \begin{bmatrix} 0.50 \angle 0^\circ \\ 0.50 \angle 240^\circ \\ 0.50 \angle 120^\circ \end{bmatrix} \text{ per unit}$$

**9.44**  $\bar{I}_{1-0} = \bar{I}_{1-1} = \bar{I}_{1-2} = \frac{\bar{V}_F}{\bar{Z}_{1-0} + \bar{Z}_{1-1} + \bar{Z}_{1-2}} = \frac{1.0 \angle 0^\circ}{j(0.10 + 0.2 + 0.2)} = -j2.0$  per unit

$$\begin{bmatrix} \bar{I}_{1a}'' \\ \bar{I}_{1b}'' \\ \bar{I}_{1c}'' \end{bmatrix} = \begin{bmatrix} 1 & 1 & 1 \\ 1 & a^2 & a \\ 1 & a & a^2 \end{bmatrix} \begin{bmatrix} -j2 \\ -j2 \\ -j2 \end{bmatrix} = \begin{bmatrix} 6.0 \angle -90^\circ \\ 0 \\ 0 \end{bmatrix} \text{ per unit}$$

$$\begin{bmatrix} \bar{V}_{2-0} \\ \bar{V}_{2-1} \\ \bar{V}_{2-2} \end{bmatrix} = \begin{bmatrix} 0 \\ 1.0 \angle 0^\circ \\ 0 \end{bmatrix} - \begin{bmatrix} 0 & 0 & 0 \\ 0 & j0.10 & 0 \\ 0 & 0 & j0.10 \end{bmatrix} \begin{bmatrix} -j2 \\ -j2 \\ -j2 \end{bmatrix} = \begin{bmatrix} 0 \\ 0.80 \\ -0.20 \end{bmatrix} \text{ per unit}$$

$$\begin{bmatrix} \bar{V}_{2ag} \\ \bar{V}_{2bg} \\ \bar{V}_{2cg} \end{bmatrix} = \begin{bmatrix} 1 & 1 & 1 \\ 1 & a^2 & a \\ 1 & a & a^2 \end{bmatrix} \begin{bmatrix} 0 \\ 0.80 \\ -0.20 \end{bmatrix} = \begin{bmatrix} 0.60j0 \\ -0.30 - j0.866 \\ -0.30 + j0.866 \end{bmatrix} \text{ per unit}$$

$$9.45 \quad \bar{I}_{1-1} = -\bar{I}_{1-2} = \frac{\bar{V}_F}{\bar{Z}_{11-1} + \bar{Z}_{11-2}} = \frac{1.0 \angle 0^\circ}{j(0.2 + 0.2)} = 2.5 \angle -90^\circ \text{ per unit}$$

$$\begin{bmatrix} \bar{I}_{1a}'' \\ \bar{I}_{1b}'' \\ \bar{I}_{1c}'' \end{bmatrix} = \begin{bmatrix} 1 & 1 & 1 \\ 1 & a^2 & a \\ 1 & a & a^2 \end{bmatrix} \begin{bmatrix} 0 \\ -j2.5 \\ +j2.5 \end{bmatrix} = \begin{bmatrix} 0 \\ -2.5\sqrt{3} \\ +2.5\sqrt{3} \end{bmatrix} \text{ per unit}$$

$$\begin{bmatrix} \bar{V}_{2-0} \\ \bar{V}_{2-1} \\ \bar{V}_{2-2} \end{bmatrix} = \begin{bmatrix} 0 \\ 1.0 \angle 0^\circ \\ 0 \end{bmatrix} - \begin{bmatrix} 0 & 0 & 0 \\ 0 & j0.10 & 0 \\ 0 & 0 & j0.10 \end{bmatrix} \begin{bmatrix} 0 \\ -j2.5 \\ +j2.5 \end{bmatrix} = \begin{bmatrix} 0 \\ 0.75 \\ 0.25 \end{bmatrix} \text{ per unit}$$

$$\begin{bmatrix} \bar{V}_{2ag} \\ \bar{V}_{2bg} \\ \bar{V}_{2cg} \end{bmatrix} = \begin{bmatrix} 1 & 1 & 1 \\ 1 & a^2 & a \\ 1 & a & a^2 \end{bmatrix} \begin{bmatrix} 0 \\ 0.75 \\ 0.25 \end{bmatrix} = \begin{bmatrix} 1.0 \\ -0.50 - j0.433 \\ -0.50 + j0.433 \end{bmatrix} \text{ per unit}$$

$$9.46 \quad \bar{I}_{1-1} = \frac{\bar{V}_F}{\bar{Z}_{11-1} + \bar{Z}_{11-2} // \bar{Z}_{11-0}} = \frac{1.0 \angle 0^\circ}{j \left[ 0.20 + \frac{(0.20)(0.10)}{0.30} \right]} = 3.75 \angle -90^\circ \text{ per unit}$$

$$\bar{I}_{1-2} = (3.75 \angle +90^\circ) \left( \frac{0.10}{0.30} \right) = 1.25 \angle 90^\circ \text{ per unit}$$

$$\bar{I}_{1-0} = (3.75 \angle +90^\circ) \left( \frac{0.20}{0.30} \right) = 2.50 \angle 90^\circ$$

$$\begin{bmatrix} \bar{I}_{1a}'' \\ \bar{I}_{1b}'' \\ \bar{I}_{1c}'' \end{bmatrix} = \begin{bmatrix} 1 & 1 & 1 \\ 1 & a^2 & a \\ 1 & a & a^2 \end{bmatrix} \begin{bmatrix} j2.50 \\ -j3.75 \\ j1.25 \end{bmatrix} = \begin{bmatrix} 0 \\ -4.330 + j1.25 \\ +4.330 + j1.25 \end{bmatrix} \text{ per unit}$$

$$\begin{bmatrix} \bar{V}_{2-0} \\ \bar{V}_{2-1} \\ \bar{V}_{2-2} \end{bmatrix} = \begin{bmatrix} 0 \\ 1.0 \angle 0^\circ \\ 0 \end{bmatrix} - \begin{bmatrix} 0 & 0 & 0 \\ 0 & j0.10 & 0 \\ 0 & 0 & j0.10 \end{bmatrix} \begin{bmatrix} j2.50 \\ -j3.75 \\ j1.25 \end{bmatrix} = \begin{bmatrix} 0 \\ 0.625 \\ 0.125 \end{bmatrix} \text{ per unit}$$

$$\begin{bmatrix} \bar{V}_{2ag} \\ \bar{V}_{2bg} \\ \bar{V}_{2cg} \end{bmatrix} = \begin{bmatrix} 1 & 1 & 1 \\ 1 & a^2 & a \\ 1 & a & a^2 \end{bmatrix} \begin{bmatrix} 0 \\ 0.625 \\ 0.125 \end{bmatrix} = \begin{bmatrix} 0.75 \\ -0.375 - j0.433 \\ -0.375 + j0.433 \end{bmatrix} \text{ per unit}$$

**9.47** Zero sequence bus impedance matrix:

Step (1): Add  $\bar{Z}_b = j0.10$  from the reference to bus 1 (type 1)  $\bar{Z}_{bus-0} = j0.10$  per unit

Step (2) : Add  $\bar{Z}_6 = j0.60$  from bus 1 to bus 2 (type 2)

$$\bar{Z}_{bus-0} = j \begin{bmatrix} 0.10 & 0.10 \\ 0.10 & 0.70 \end{bmatrix} \text{per unit}$$

Step (3): Add  $\bar{Z}_b = j0.10$  from the reference to bus 2 (type 3)

$$\bar{Z}_{bus-0} = j \begin{bmatrix} 0.10 & 0.10 \\ 0.10 & 0.70 \end{bmatrix} - \frac{j}{0.80} \begin{bmatrix} 0.10 \\ 0.70 \end{bmatrix} \begin{bmatrix} 0.10 & 0.70 \end{bmatrix} = j \begin{bmatrix} 0.0875 & 0.0125 \\ 0.0125 & 0.0875 \end{bmatrix}$$

Step (4): Add  $\bar{Z}_b = j0.40$  from bus 2 to bus 3 (type 2)

$$\bar{Z}_{bus-0} = j \begin{bmatrix} 0.0875 & 0.0125 & 0.0125 \\ 0.0125 & 0.0875 & 0.0875 \\ 0.0125 & 0.0875 & 0.4875 \end{bmatrix} \text{per unit}$$

Step (5): Add  $\bar{Z}_b = j0.40$  from bus 1 to bus 3 (type 4)

$$\begin{aligned} \bar{Z}_{bus-0} &= j \begin{bmatrix} 0.0875 & 0.0125 & 0.0125 \\ 0.0125 & 0.0875 & 0.0875 \\ 0.0125 & 0.0875 & 0.4875 \end{bmatrix} - \frac{j}{0.95} \begin{bmatrix} 0.075 \\ -0.075 \\ -0.475 \end{bmatrix} \begin{bmatrix} 0.075 & -0.075 & -0.475 \end{bmatrix} \\ &= j \begin{bmatrix} 0.08158 & 0.01842 & 0.050 \\ 0.01842 & 0.08158 & 0.050 \\ 0.050 & 0.050 & 0.250 \end{bmatrix} \text{per unit} \end{aligned}$$

Positive sequence Bus Impedance Matrix:

Step (1): Add  $\bar{Z}_b = j0.25$  from the reference to bus 1 (type 1)

$$\bar{Z}_{bus-1} = j0.25 \text{ per unit}$$

Step (2): Add  $\bar{Z}_b = j0.20$  from bus 1 to bus 2 (type 2)

$$\bar{Z}_{bus-1} = j \begin{bmatrix} 0.25 & 0.25 \\ 0.25 & 0.45 \end{bmatrix} \text{per unit}$$

Step (3): Add  $\bar{Z}_b = j0.35$  from the reference to bus 2 (types)

$$\bar{Z}_{bus-1} = j \begin{bmatrix} 0.25 & 0.25 \\ 0.25 & 0.45 \end{bmatrix} - \frac{j}{0.8} \begin{bmatrix} 0.25 \\ 0.45 \end{bmatrix} \begin{bmatrix} 0.25 & 0.45 \end{bmatrix} = j \begin{bmatrix} 0.1719 & 0.1094 \\ 0.1094 & 0.1969 \end{bmatrix}$$

Step (4): Add  $\bar{Z}_b = j0.16$  from bus 2 to bus 3 (type 2)

$$\bar{Z}_{bus-1} = j \begin{bmatrix} 0.1719 & 0.1094 & 0.1094 \\ 0.1094 & 0.1969 & 0.1969 \\ 0.1094 & 0.1969 & 0.3569 \end{bmatrix} \text{per unit}$$

Step (5): Add  $\bar{Z}_b = j0.16$  from bus 1 to bus 3 (type 4)

$$\begin{aligned}\bar{Z}_{bus-1} &= j \begin{bmatrix} 0.1719 & 0.1094 & 0.1094 \\ 0.1094 & 0.1969 & 0.1969 \\ 0.1094 & 0.1969 & 0.3569 \end{bmatrix} - \frac{j}{0.47} \begin{bmatrix} 0.0625 \\ -0.0875 \\ -0.2475 \end{bmatrix} \begin{bmatrix} 0.0625 & -0.0875 & -0.2475 \end{bmatrix} \\ &= j \begin{bmatrix} 0.1636 & 0.1210 & 0.1423 \\ 0.1210 & 0.1806 & 0.1508 \\ 0.1423 & 0.1508 & 0.2266 \end{bmatrix} \text{ per unit}\end{aligned}$$

Step (6): Add  $\bar{Z}_b = j(0.5786 \parallel 0.4853) = j0.2639$  from the reference to bus 3 (type 3)

$$\begin{aligned}\bar{Z}_{bus-1} &= j \begin{bmatrix} 0.1636 & 0.1210 & 0.1423 \\ 0.1210 & 0.1806 & 0.1508 \\ 0.1423 & 0.1508 & 0.2266 \end{bmatrix} - \frac{j}{0.4905} \begin{bmatrix} 0.1423 \\ 0.1508 \\ 0.2266 \end{bmatrix} \begin{bmatrix} 0.1423 & 0.1508 & 0.2266 \end{bmatrix} \\ &= j \begin{bmatrix} 0.1223 & 0.0773 & 0.0766 \\ 0.0773 & 0.1342 & 0.0811 \\ 0.0766 & 0.0811 & 0.1219 \end{bmatrix} \text{ per unit}\end{aligned}$$

Negative Sequence Bus Impedance Matrix: Steps (1)–(5) are the same as for  $\bar{Z}_{bus-1}$ . Step (6): Add  $\bar{Z}_b = j(0.5786 \parallel .5981) = j0.2941$  from the reference to bus 3 (types 3).

$$\begin{aligned}\bar{Z}_{bus-1} &= j \begin{bmatrix} 0.1636 & 0.1210 & 0.1423 \\ 0.1210 & 0.1806 & 0.1508 \\ 0.1423 & 0.1508 & 0.2266 \end{bmatrix} - \frac{j}{0.5207} \begin{bmatrix} 0.1423 \\ 0.1508 \\ 0.2266 \end{bmatrix} \begin{bmatrix} 0.1423 & 0.1508 & 0.2266 \end{bmatrix} \\ &= j \begin{bmatrix} 0.1247 & 0.0798 & 0.0804 \\ 0.0798 & 0.1369 & 0.0852 \\ 0.0804 & 0.0852 & 0.1280 \end{bmatrix}\end{aligned}$$

**9.48** From the results of Problem 9.47,  $\bar{Z}_{11-0} = j0.08158$ ,  $\bar{Z}_{11-1} = j0.1223$  and  $\bar{Z}_{11-2} = j0.1247$  per unit are the same as the thevenin equivalent sequence impedances at bus 1 as calculated in Problem 9.4(b). Therefore the fault currents calculated from the sequence impedance matrices will be the same as those calculated in problems 9.4(c) and 9.19(a) through 9.19(d).

**9.49** Zero sequence bus impedance matrix:

Step (1): Add  $\bar{Z}_b = j0.24$  from the reference to bus 1 (type 1)

$$\bar{Z}_{bus-0} = j[0.24] \text{ per unit}$$

Step (2): Add  $\bar{Z}_b = j0.6$  from bus 1 to bus 2 (type 2)

$$\bar{Z}_{bus-0} = j \begin{bmatrix} 0.24 & 0.24 \\ 0.24 & 0.84 \end{bmatrix} \text{ per unit}$$

Step (3): Add  $\bar{Z}_b = j0.6$  from bus 2 to bus 3 (type 2)

$$\bar{Z}_{bus-0} = j \begin{bmatrix} 0.24 & 0.24 & 0.24 \\ 0.24 & 0.84 & 0.84 \\ 0.24 & 0.84 & 1.44 \end{bmatrix} \text{ per unit}$$

Step (4): Add  $\bar{Z}_b = j0.10$  from the reference to bus 3 (type 3)

$$\bar{Z}_{bus-0} = j \begin{bmatrix} .24 & .24 & .24 \\ .24 & .84 & .84 \\ .24 & .84 & 1.44 \end{bmatrix} - \frac{j}{1.54} \begin{bmatrix} .24 \\ .84 \\ 1.44 \end{bmatrix} \begin{bmatrix} .24 & .84 & 1.44 \end{bmatrix}$$

$$\bar{Z}_{bus-0} = j \begin{bmatrix} 0.2026 & 0.1091 & 0.01558 \\ 0.1091 & 0.3818 & 0.05455 \\ 0.01558 & 0.05455 & 0.09351 \end{bmatrix} \text{ per unit}$$

Step (5): Add  $\bar{Z}_b = j0.6$  from bus 2 to bus 4 (type 2)

$$\bar{Z}_{bus-0} = j \begin{bmatrix} 0.2026 & 0.1091 & 0.01558 & 0.1091 \\ 0.1091 & 0.3818 & 0.05455 & 0.3818 \\ 0.01558 & 0.05455 & 0.09351 & 0.05455 \\ 0.1091 & 0.3818 & 0.05455 & 0.9818 \end{bmatrix} \text{ per unit}$$

Step (6): Add  $\bar{Z}_b = j0.1333$  from the reference bus to bus 4 (type 3)

$$\bar{Z}_{bus-0} = j \begin{bmatrix} .2026 & .1091 & .01558 & .1091 \\ .1091 & .3818 & .05455 & .3818 \\ .01558 & .05455 & .09351 & .05455 \\ .1091 & .3818 & .05455 & .9818 \end{bmatrix} - \frac{j}{1.1151} \begin{bmatrix} .1091 \\ .3818 \\ .05455 \\ .9818 \end{bmatrix} \begin{bmatrix} .1091 & .3818 & .05455 & .9818 \end{bmatrix}$$

$$\bar{Z}_{bus-0} = j \begin{bmatrix} 0.1919 & 0.07175 & 0.01024 & 0.01304 \\ 0.07175 & 0.2511 & 0.03587 & 0.04564 \\ 0.01024 & 0.03587 & 0.09084 & 0.006521 \\ 0.01304 & 0.04564 & 0.006521 & 0.1174 \end{bmatrix} \text{ per unit}$$

Positive sequence bus impedance matrix can be obtained as:

$$\bar{Z}_{bus-1} = j \begin{bmatrix} 0.2671 & 0.1505 & 0.0865 & 0.0980 \\ 0.1505 & 0.1975 & 0.1135 & 0.1286 \\ 0.0865 & 0.1135 & 0.1801 & 0.0739 \\ 0.0980 & 0.1286 & 0.0739 & 0.2140 \end{bmatrix} \text{ per unit}$$

Negative sequence bus impedance matrix:

Steps (1)–(4) are the same as for  $\bar{Z}_{bus-1}$

Step (5): Add  $\bar{Z}_b = j0.3$  from the reference bus to bus 3 (type 3)

$$\bar{Z}_{bus-2} = j \begin{bmatrix} .64 & .64 & .64 & .64 \\ .64 & .84 & .84 & .84 \\ .64 & .84 & 1.04 & .84 \\ .64 & .84 & .84 & 1.04 \end{bmatrix} - \frac{j}{1.34} \begin{bmatrix} .64 \\ .84 \\ 1.04 \\ .84 \end{bmatrix} \begin{bmatrix} .64 & .84 & 1.04 & .84 \end{bmatrix}$$

$$\bar{Z}_{bus-2} = j \begin{bmatrix} .3343 & .2388 & .1433 & .2388 \\ .2388 & .3134 & .1881 & .3134 \\ .1433 & .1881 & .2328 & .1881 \\ .2388 & .3134 & .1881 & .5134 \end{bmatrix} \text{ per unit}$$

Step (6): Add  $\bar{Z}_b = j0.3733$  from the reference to bus 4 (type 3)

$$\bar{Z}_{bus-2} = j \begin{bmatrix} .3343 & .2388 & .1433 & .2388 \\ .2388 & .3134 & .1881 & .3134 \\ .1433 & .1881 & .2328 & .1881 \\ .2388 & .3134 & .1881 & .5134 \end{bmatrix} - \frac{j}{.8867} \begin{bmatrix} .2388 \\ .3134 \\ .1881 \\ .5134 \end{bmatrix} \begin{bmatrix} .2388 & .3134 & .1881 & .5134 \end{bmatrix}$$

$$\bar{Z}_{bus-2} = j \begin{bmatrix} 0.2700 & 0.1544 & 0.09264 & 0.1005 \\ 0.1544 & 0.2026 & 0.1216 & 0.1319 \\ 0.09264 & 0.1216 & 0.1929 & 0.07919 \\ 0.1005 & 0.1319 & 0.07919 & 0.2161 \end{bmatrix} \text{ per unit}$$

**9.50** From the results of Problem 9.49,  $\bar{Z}_{11-0} = j0.1919$ ,  $\bar{Z}_{11-1} = j0.2671$ , and  $\bar{Z}_{11-2} = j0.2700$  per unit are the same as the Thevenin equivalent sequence impedances at bus 1, as calculated in Problem 9.6. Therefore, the fault currents calculated from the sequence impedance matrices are the same as those calculated in Problems 9.7, 9.21–9.23.

**9.51** Zero sequence bus impedance matrix: Working backwards from bus 4:

Step (1): Add  $\bar{Z}_b = j0.1$  from the reference bus to bus 4 (type 1)

$$\bar{Z}_{bus-0} = \begin{bmatrix} 4 \\ j0.1 \end{bmatrix} \text{ 4 per unit}$$

Step (2): Add  $\bar{Z}_b = j0.5251$  from bus 4 to bus 3 (type 2)

$$\bar{Z}_{bus-0} = j \begin{bmatrix} 3 & 4 \\ 0.6251 & 0.1 \end{bmatrix} \begin{bmatrix} 3 \\ 4 \end{bmatrix} \text{ per unit}$$

Step (3): Add  $\bar{Z}_b = j0.5251$  from bus 3 to bus 2 (type 2)

$$\bar{Z}_{bus-0} = j \begin{bmatrix} & 2 & 3 & 4 \\ 1.1502 & 0.6251 & 0.1 & \\ 0.6251 & 0.6251 & 0.1 & \\ 0.1 & 0.1 & 0.1 & \end{bmatrix} \begin{matrix} 2 \\ 3 \text{ per unit} \\ 4 \end{matrix}$$

Step (4): Add  $\bar{Z}_b = j0.2$  from bus 2 to bus 1 (type 2)

$$\bar{Z}_{bus-0} = j \begin{bmatrix} & 1 & 2 & 3 & 4 \\ 1.3502 & 1.1502 & 0.6251 & 0.1 & \\ 1.1502 & 1.1502 & 0.6251 & 0.1 & \\ 0.6251 & 0.6251 & 0.6251 & 0.1 & \\ 0.1 & 0.1 & 0.1 & 0.1 & \end{bmatrix} \begin{matrix} 1 \\ 2 \\ 3 \\ 4 \end{matrix} \text{ per unit}$$

Step (5): Add  $\bar{Z}_b = j0.1$  from the reference to bus 5 (type 1)

$$\bar{Z}_{bus-0} = j \begin{bmatrix} 1.3502 & 1.1502 & 0.6251 & 0.1 & 0 \\ 1.1502 & 1.1502 & 0.6251 & 0.1 & 0 \\ 0.6251 & 0.6251 & 0.6251 & 0.1 & 0 \\ 0.1 & 0.1 & 0.1 & 0.1 & 0 \\ 0 & 0 & 0 & 0 & 0.1 \end{bmatrix} \text{ per unit}$$

Positive sequence bus impedance matrix can be obtained as:

$$\bar{Z}_{bus-1} = j \begin{bmatrix} 0.3542 & 0.2772 & 0.1964 & 0.1155 & 0.0770 \\ 0.2772 & 0.3735 & 0.2645 & 0.1556 & 0.1037 \\ 0.1964 & 0.2645 & 0.3361 & 0.1977 & 0.1318 \\ 0.1155 & 0.1556 & 0.1977 & 0.2398 & 0.1599 \\ 0.0770 & 0.1037 & 0.1318 & 0.1599 & 0.1733 \end{bmatrix} \text{ per unit}$$

Negative sequence bus impedance matrix:

Steps (1) – (5) are the same as for  $\bar{Z}_{bus-1}$

Step (6): Add  $\bar{Z}_b = j0.23$  from the reference bus to bus 5 (type 3)

$$\bar{Z}_{bus-2} = j \begin{bmatrix} .576 & .576 & .576 & .576 & .576 \\ .576 & .776 & .776 & .776 & .776 \\ .576 & .776 & .986 & .986 & .986 \\ .576 & .776 & .986 & 1.196 & 1.196 \\ .576 & .776 & .986 & 1.196 & 1.296 \end{bmatrix} - \frac{j}{1.526} \begin{bmatrix} .576 \\ .776 \\ .986 \\ 1.196 \\ 1.296 \end{bmatrix} \begin{bmatrix} .576 & .776 & .986 & 1.196 & 1.296 \end{bmatrix}$$



$$\bar{Z}_{bus-2} = j \begin{bmatrix} 0.3586 & 0.2831 & 0.2038 & 0.1246 & 0.08682 \\ 0.2831 & 0.3814 & 0.2746 & 0.1678 & 0.1170 \\ 0.2038 & 0.2746 & 0.3489 & 0.2132 & 0.1486 \\ 0.1246 & 0.1678 & 0.2132 & 0.2586 & 0.1803 \\ 0.08682 & 0.1170 & 0.1486 & 0.1803 & 0.1953 \end{bmatrix} \text{ per unit}$$

**9.52** From the results of Problem 9.51  $\bar{Z}_{11-0} = j1.3502$ ,  $\bar{Z}_{11-1} = j0.3542$ , and  $\bar{Z}_{11-2} = j0.3586$  per unit are the same as the Thevenin equivalent sequence impedances at bus 1, as calculated in Problem 9.9. Therefore, the fault currents calculated from the sequence impedance matrices are the same as those calculated in Problem 9.10, 9.24–9.27.

**9.53** (a) & (b) Either by inverting  $\bar{Y}_{BUS}$  or by the building algorithm  $\bar{Z}_{BUS}$  can be obtained as

$$\bar{Z}_{BUS} = \begin{matrix} & \begin{matrix} (1) & (2) & (3) & (4) & (5) \end{matrix} \\ \begin{matrix} (1) \\ (2) \\ (3) \\ (4) \\ (5) \end{matrix} & \begin{bmatrix} j0.0793 & j0.0558 & j0.0382 & j0.0511 & j0.0608 \\ j0.0558 & j0.1338 & j0.0664 & j0.0630 & j0.0605 \\ j0.0382 & j0.0664 & j0.0875 & j0.0720 & j0.0603 \\ j0.0511 & j0.0630 & j0.0720 & j0.2321 & j0.1002 \\ j0.0608 & j0.0605 & j0.0603 & j0.1002 & j0.1301 \end{bmatrix} \end{matrix}$$

(c) Thevenin equivalent circuits to calculate voltages at bus (3) and bus (5) due to fault at bus (4) are shown below:

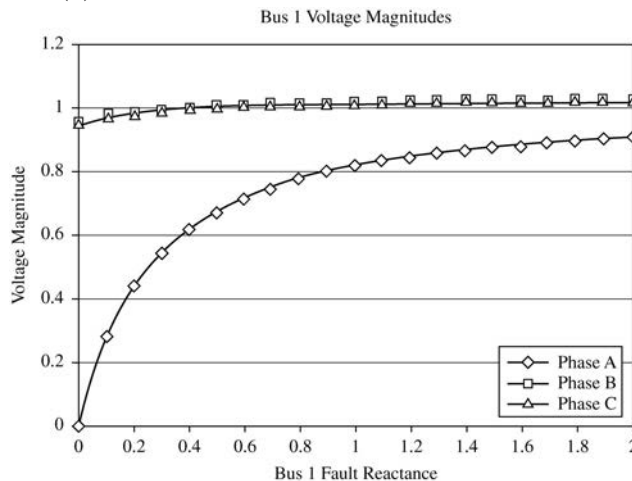

Simply by closing 8, the subtransient current in the 3-phase fault at bus (4) is given by

$$\bar{I}_f'' = \frac{1.0}{j0.2321} = -j4.308$$

The voltage at bus (3) during the fault is

$$\bar{V}_3 = \bar{V}_f - \bar{I}_f'' \bar{Z}_{34} = 1 - (-j4.308)(j0.0720) = 0.6898$$

The voltage at bus (5) during the fault is

$$\bar{V}_5 = \bar{V}_f - \bar{I}_f'' \bar{Z}_{54} = 1 - (-j4.308)(j0.1002) = 0.5683$$

Currents into the fault at bus (4) over the line impedances are

$$\text{From bus (3): } \frac{0.6898}{j0.336} = -j2.053$$

$$\text{From bus (5): } \frac{0.5683}{j0.252} = -j2.255$$

Hence, total fault current at bus (4) =  $-j4.308$  pu

**9.54** The impedance of line (1)–(2) is  $\bar{Z}_b = j0.168$ .

$\bar{Z}_{BUS}$  is given in the solution of Prob. 9.53.

The Thévenin equivalent circuit looking into the system between buses (1) and (2) is shown below:

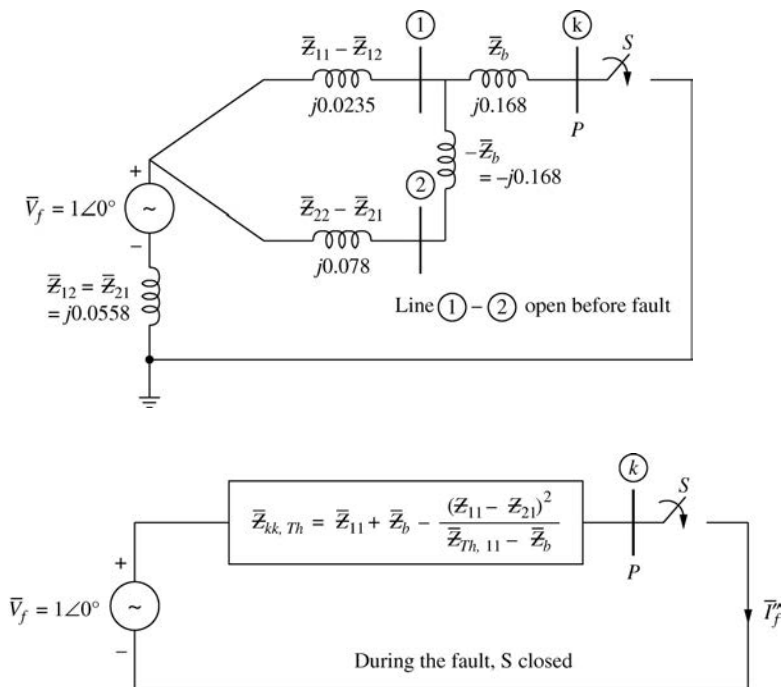

$$\bar{Z}_{kk,Th} = j0.168 + \frac{(j0.0235)(-j0.09)}{j(0.0235 - 0.09)} + j0.0558 = j0.2556$$

$$\therefore \text{Subtransient current into line-end fault } \bar{I}_f'' = 1 / j0.2556 = -j3.912 \text{ pu}$$

9.55 (a)

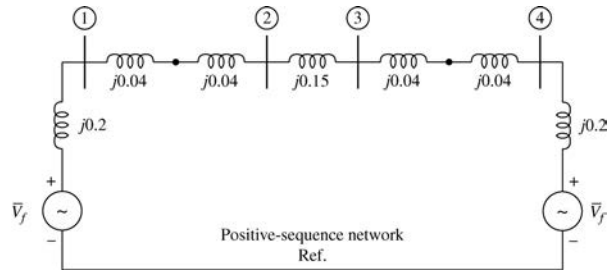

Negative-sequence network is same as above without sources.

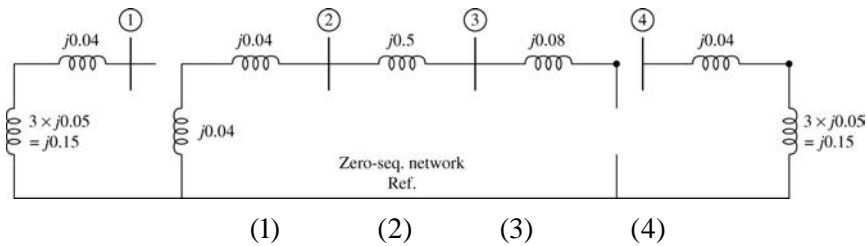

$$\bar{Z}_{BUS1} = \bar{Z}_{BUS2} = \begin{matrix} (1) & (2) & (3) & (4) \\ \begin{bmatrix} j0.1437 & j0.1211 & j0.0789 & j0.0563 \\ j0.1211 & j0.1696 & j0.1104 & j0.0789 \\ j0.0789 & j0.1104 & j0.1696 & j0.1211 \\ j0.0563 & j0.0789 & j0.1211 & j0.1437 \end{bmatrix} \end{matrix}$$

$$\bar{Z}_{BUS0} = \begin{matrix} (1) & (2) & (3) & (4) \\ \begin{bmatrix} j0.19 & 0 & 0 & 0 \\ 0 & j0.08 & j0.08 & 0 \\ 0 & j0.08 & j0.58 & 0 \\ 0 & 0 & 0 & j0.19 \end{bmatrix} \end{matrix}$$

(b) For the line-to-line fault, Thévenin equivalent circuit:

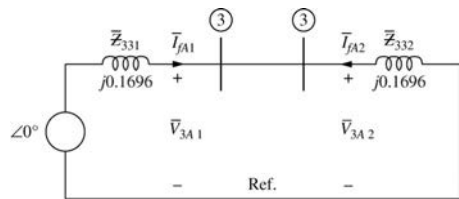

Upper case A is used because fault is in the HV-transmission line circuit.

$$\bar{I}_{fA1} = -\bar{I}_{fA2} = \frac{1\angle 0^\circ}{j0.1696 + j0.1696} = -j2.9481$$

$$\bar{I}_{fA} = \bar{I}_{fA1} + \bar{I}_{fA2} = 0$$

$$\bar{I}_{fB} = a^2 \bar{I}_{fA1} + a \bar{I}_{fA2} = -5.1061 + j0 = 855\angle 180^\circ \text{ A}$$

$$\bar{I}_{fC} = -\bar{I}_{fB} = 5.1061 + j0 = 855\angle 0^\circ \text{ A}$$

$\therefore$  Base current in HV transmission line is  $\frac{100,000}{\sqrt{3} \times 345} = 167.35 \text{ A}$

Symmetrical components of phase-A voltage to ground at bus (3) are

$$\bar{V}_{3A0} = 0; \bar{V}_{3A1} = \bar{V}_{3A2} = 1 - (j0.1696)(-j2.9481) = 0.5 + j0$$

Line-to-Ground voltages at fault bus (3) are

$$\bar{V}_{3A} = \bar{V}_{3A0} + \bar{V}_{3A1} + \bar{V}_{3A2} = 0 + 0.5 + 0.5 = 1 \angle 0^\circ$$

$$\bar{V}_{3B} = \bar{V}_{3A0} + a^2 \bar{V}_{3A1} + a \bar{V}_{3A2} = 0.5 \angle 180^\circ$$

$$\bar{V}_{3C} = \bar{V}_{3B} = 0.5 \angle 180^\circ$$

Line-to-line voltages at fault bus (3) are

$$\bar{V}_{3,AB} = \bar{V}_{3A} - \bar{V}_{3B} = 1.5 \angle 0^\circ = 1.5 \times \frac{345}{\sqrt{3}} = 299 \angle 0^\circ \text{ kV}$$

$$\bar{V}_{3,BC} = \bar{V}_{3B} - \bar{V}_{3C} = 0$$

$$\bar{V}_{3,CA} = \bar{V}_{3C} - \bar{V}_{3A} = 1.5 \angle 180^\circ = 299 \angle 180^\circ \text{ kV}$$

Avoiding, for the moment, phase shifts due to  $\Delta - Y$  transformer connected to machine 2, sequence voltages of phase A at bus (4) using the bus-impedance matrix are calculated as

$$\bar{V}_{4A0} = -\bar{Z}_{430} \bar{I}_{fA0} = 0$$

$$\bar{V}_{4A1} = \bar{V}_f - \bar{Z}_{431} \bar{I}_{fA1} = 1 - (j0.1211)(-j2.9481) = 0.643$$

$$\bar{V}_{4A2} = -\bar{Z}_{432} \bar{I}_{fA2} = -(j0.1211)(j2.9481) = 0.357$$

Accounting for phase shifts

$$\bar{V}_{4a1} = \bar{V}_{4A1} \angle -30^\circ = 0.643 \angle -30^\circ = 0.5569 - j0.3215$$

$$\bar{V}_{4a2} = \bar{V}_{4A2} \angle 30^\circ = 0.357 \angle 30^\circ = 0.3092 + j0.1785$$

$$\bar{V}_{4a} = \bar{V}_{4a0} + \bar{V}_{4a1} + \bar{V}_{4a2} = 0.8661 - j0.143 = 0.8778 \angle -9.4^\circ$$

Phase-b voltages at terminals of machine 2 are

$$\bar{V}_{4b0} = \bar{V}_{4a0} = 0$$

$$\bar{V}_{4b1} = a^2 \bar{V}_{4a1} = 0.643 \angle 240^\circ - 30^\circ = -0.3569 - j0.3215$$

$$\bar{V}_{4b2} = a \bar{V}_{4a2} = 0.357 \angle 120^\circ + 30^\circ = -0.3092 + j0.1785$$

$$\bar{V}_{4b} = \bar{V}_{4b0} + \bar{V}_{4b1} + \bar{V}_{4b2} = -0.8661 - j0.143 = 0.8778 \angle -170.6^\circ$$

For phase C of machine 2,

$$\bar{V}_{4c0} = \bar{V}_{4a0} = 0$$

$$\bar{V}_{4c1} = a \bar{V}_{4a1} = 0.643 \angle 90^\circ; \bar{V}_{4c2} = a^2 \bar{V}_{4a2} = 0.357 \angle -90^\circ$$

$$\bar{V}_{4c} = \bar{V}_{4c0} + \bar{V}_{4c1} + \bar{V}_{4c2} = j0.286$$

Line-to-line voltages at terminals of machine 2 are given by

$$\bar{V}_{4,ab} = \bar{V}_{4a} - \bar{V}_{4b} = 1.7322 + j0 = 1.7322 \times \frac{20}{\sqrt{3}} = 20 \angle 0^\circ \text{ kV}$$

$$\bar{V}_{4,bc} = \bar{V}_{4b} - \bar{V}_{4c} = -0.8661 - j0.429 = 0.9665 \angle -153.65^\circ = 11.2 \text{ kV} \angle -153.65^\circ$$

$$\bar{V}_{4,ca} = \bar{V}_{4c} - \bar{V}_{4a} = -0.8661 + j0.429 = 0.9665 \angle 153.65^\circ = 11.2 \text{ kV} \angle 153.65^\circ$$

- (c) For the double line-to-line fault, connection of Thévenin equivalents of sequence networks is shown below:

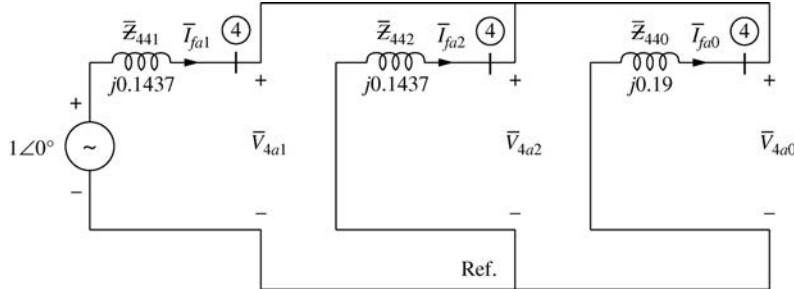

$$\bar{I}_{fa1} = \frac{1 \angle 0^\circ}{j0.1437 + \frac{j0.1437(j0.19)}{j(0.1437 + 0.19)}} = -j4.4342$$

Sequence voltages at the fault are

$$\bar{V}_{4a1} = \bar{V}_{4a2} = \bar{V}_{4a0} = 1 - (-j4.4342)(j0.1437) = 0.3628$$

$$\bar{I}_{fa2} = j4.4342 \frac{j0.19}{j(0.1437 + 0.19)} = j2.5247$$

$$\bar{I}_{fa0} = j4.4342 \frac{j0.1437}{j(0.1437 + 0.19)} = j1.9095$$

Currents out of the system at the fault point are

$$\bar{I}_{fa} = \bar{I}_{fa0} + \bar{I}_{fa1} + \bar{I}_{fa2} = 0$$

$$\bar{I}_{fb} = \bar{I}_{fa0} + a^2 \bar{I}_{fa1} + a \bar{I}_{fa2} = -6.0266 + j2.8642 = 6.6726 \angle 154.6^\circ$$

$$\bar{I}_{fc} = \bar{I}_{fa0} + a \bar{I}_{fa1} + a^2 \bar{I}_{fa2} = 6.0266 + j2.8642 = 6.6726 \angle 25.4^\circ$$

Current  $I_f$  into the ground is

$$\bar{I}_f = \bar{I}_{fb} + \bar{I}_{fc} = 3\bar{I}_{fa0} = j5.7285$$

a-b-c voltages at the fault bus are

$$\bar{V}_{4a} = \bar{V}_{4a0} + \bar{V}_{4a1} + \bar{V}_{4a2} = 3\bar{V}_{4a1} = 3(0.3628) = 1.0884$$

$$\bar{V}_{4b} = \bar{V}_{4c} = 0$$

$$\bar{V}_{4,ab} = \bar{V}_{4a} - \bar{V}_{4b} = 1.0884; \bar{V}_{4,bc} = \bar{V}_{4b} - \bar{V}_{4c} = 0;$$

$$\bar{V}_{4,ca} = \bar{V}_{4c} - \bar{V}_{4a} = -1.0884$$

$$\text{Base current} = \frac{100 \times 10^3}{\sqrt{3} \times 20} = 2887 \text{ A}$$

$$\therefore \bar{I}_{fa} = 0; \bar{I}_{fb} = 19.262 \angle 154.6^\circ \text{ kA}; \bar{I}_{fc} = 19.262 \angle 25.4^\circ \text{ kA}$$

$$\bar{I}_f = 16.538 \angle 90^\circ \text{ kA}$$

Base line-to-neutral voltage in machine 2 is  $20/\sqrt{3}$  kV

$$\therefore \bar{V}_{4,ab} = 12.568 \angle 0^\circ \text{ kV}; \bar{V}_{4,bc} = 0; \bar{V}_{4,ca} = 12.568 \angle 180^\circ \text{ kV}$$

- 9.56** (a)  $\bar{Z}_{BUS1}$  and  $\bar{Z}_{BUS2}$  are same as in the solution of Prob. 9.51. however, because the transformers are solidly grounded on both sides, the zero-sequence network is changed as shown below:

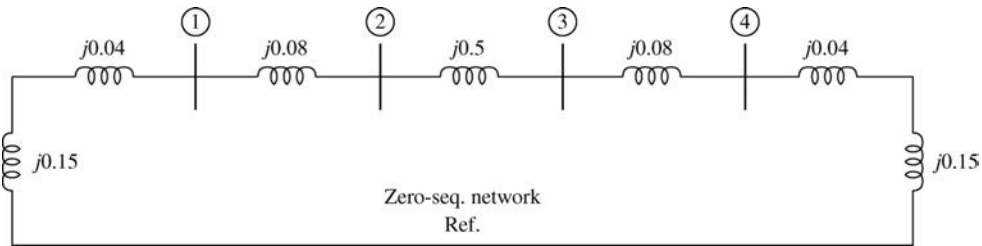

For the single line-to-ground fault, series connection of the Thévenin equivalents of the sequence networks is shown below:

$$\bar{Z}_{BUS0} = \begin{matrix} & \begin{matrix} (1) & (2) & (3) & (4) \end{matrix} \\ \begin{matrix} (1) \\ (2) \\ (3) \\ (4) \end{matrix} & \begin{bmatrix} j0.1553 & j0.1407 & j0.0493 & j0.0347 \\ j0.01407 & j0.1999 & j0.0701 & j0.0493 \\ j0.0493 & j0.0701 & j0.1999 & j0.1407 \\ j0.0347 & j0.0493 & j0.1407 & j0.1553 \end{bmatrix} \end{matrix}$$

(b)  $\bar{I}_{fA0} = \bar{I}_{fA1} = \bar{I}_{fA2}$

$$= \frac{1 \angle 0^\circ}{j(0.1696 + 0.1696 + 0.1999)}$$

$$= -j1.8549$$

$$\bar{I}_{fA} = 3\bar{I}_{fA0} = -j5.5648 = 931 \angle 270^\circ \text{ A}$$

$\therefore$  Base current in HV trans. line is

$$\frac{100,000}{\sqrt{3} \times 345} = 167.35 \text{ A}$$

Phase-a sequence voltages at bus (4), terminals of machine 2, are

$$\bar{V}_{4a0} = -\bar{Z}_{430} \bar{I}_{fA0} = -(j0.1407)(-j1.8549) = -0.2610$$

$$\bar{V}_{4a1} = 1 - (j0.1211)(-j1.8549) = 0.7754 \left[ = \bar{V}_f - \bar{Z}_{431} \bar{I}_{fA1} \right]$$

$$\bar{V}_{4a2} = -(j0.1211)(-j1.8549) = -0.2246 \left[ = -\bar{Z}_{432} \bar{I}_{fA2} \right]$$

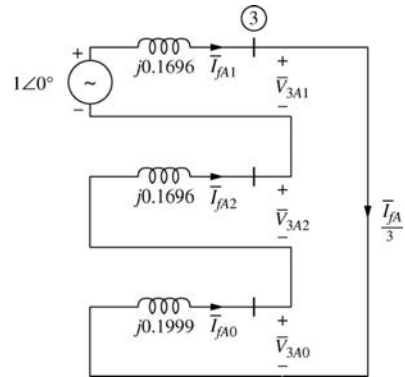

Note: Subscripts A and a denote HV and LV circuits, respectively, of the Y-Y connected transformer. No phase shift is involved.

$$\begin{bmatrix} \bar{V}_{4a} \\ \bar{V}_{4b} \\ \bar{V}_{4c} \end{bmatrix} = \begin{bmatrix} 1 & 1 & 1 \\ 1 & a^2 & a \\ 1 & a & a^2 \end{bmatrix} \begin{bmatrix} -0.2610 \\ +0.7754 \\ -0.2246 \end{bmatrix} = \begin{bmatrix} 0.2898 + j0 \\ -0.5364 - j0.866 \\ -0.5364 + j0.866 \end{bmatrix} = \begin{bmatrix} 0.2898 \angle 0^\circ \\ 1.0187 \angle -121.8^\circ \\ 1.0187 \angle 121.8^\circ \end{bmatrix}$$

Line-to-ground voltages of machine 2 in kV are: (Multiply by  $20/\sqrt{3}$ )

$$\bar{V}_{4a} = 3.346 \angle 0^\circ \text{ kV}; \bar{V}_{4b} = 11.763 \angle -121.8^\circ \text{ kV}; \bar{V}_{4c} = 11.763 \angle 121.8^\circ \text{ kV}$$

Symmetrical components of phase-a current are

$$\bar{I}_{a0} = -\frac{\bar{V}_{4a0}}{jX_0} = \frac{0.2610}{j0.04} = -j6.525$$

$$\bar{I}_{a1} = \frac{\bar{V}_f - \bar{V}_{4a1}}{jX''} = \frac{1.0 - 0.7754}{j0.2} = -j1.123$$

$$\bar{I}_{a2} = -\frac{\bar{V}_{4a2}}{jX_2} = \frac{0.2246}{j0.2} = -j1.123$$

The phase-c currents in machine 2 are calculated as

$$\begin{aligned} \bar{I}_c &= \bar{I}_{a0} + a\bar{I}_{a1} + a^2\bar{I}_{a2} \\ &= -j6.525 + a(-j1.123) + a^2(-j1.123) \\ &= -j5.402 \end{aligned}$$

$$\text{Base current in the machine circuit is } \frac{100 \times 10^3}{\sqrt{3}(20)} = 2886.751 \text{ A}$$

$$\therefore I_c = 15,594 \text{ A}$$

**9.57** Using equations (9.5.9) in (8.1.3), the phase “a” voltage at bus k for a fault at bus n is:

$$\begin{aligned} V_{ka} &= V_{k-0} + V_{k-1} + V_{k-2} \\ &= V_F - (Z_{kn-0}I_{n-0} + Z_{kn-1}I_{n-1} + Z_{kn-2}I_{n-2}) \end{aligned}$$

For a single line-to-ground fault, (9.5.3),

$$I_{n-0} = I_{n-1} = I_{n-2} = \frac{V_F}{Z_{nn-0} + Z_{nn-1} + Z_{nn-2} + 3Z_F}$$

Therefore,

$$V_{ka} = V_F \left[ 1 - \frac{Z_{kn-0} + Z_{kn-1} + Z_{kn-2}}{Z_{nn-0} + Z_{nn-1} + Z_{nn-2} + 3Z_F} \right]$$

The results in Table 9.5 for Example 9.8 neglect resistance of all components (machines, transformers, transmission lines). Also the fault impedance  $Z_F$  is zero. As such, the impedance in the above equation all have the same phase angle (90°), and the phase “a” voltage  $V_{ka}$  therefore has the same angle as the prefault voltage  $V_F$ , which is zero degrees.

Note also that pre-fault load currents are neglected.

Note, the PowerWorld problems in Chapter 9 were solved ignoring the effect of the  $\Delta - Y$  transformer phase shift [see Example 9.6]. An upgraded version of PowerWorld Simulator is available from [www.powerworld.com/gloversarma](http://www.powerworld.com/gloversarma) that (optionally) allows inclusion of this phase shift.

**9.58** During a double line-to-ground fault the bus 2 voltage on the unfaulted phase rises to 1.249 per unit.

**9.59**

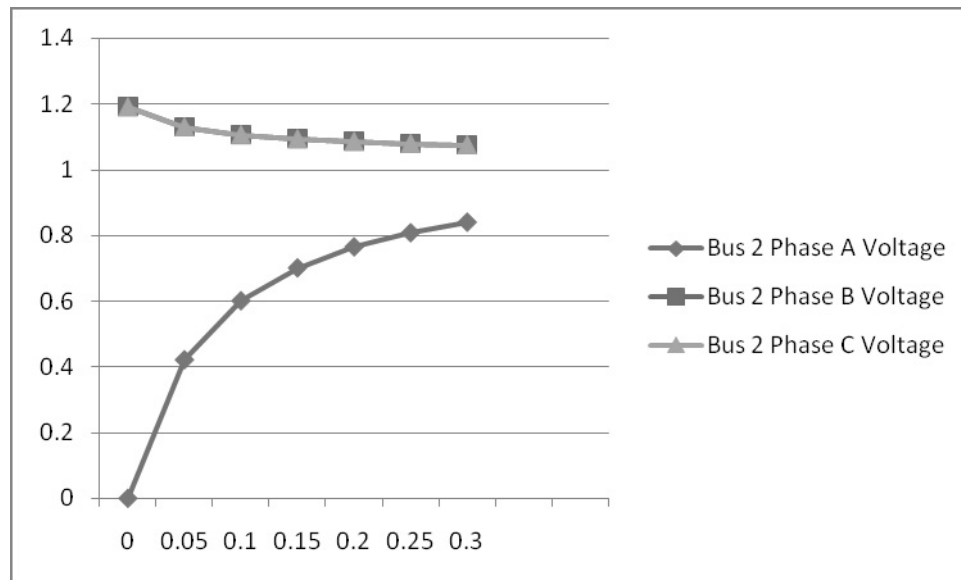

**9.60** For a line-to-line fault the magnitude of the per unit fault currents are 32.507 for a bus 1 fault, 15.967 for a bus 2 fault, 49.845 for a bus 3 fault, 38.5 for a bus 4 fault, and 30.851 for a bus 5 fault. All values are lower than for the single line-to-ground case, except at bus 2 it is slightly higher.

**9.61** For a double line-to-ground fault the magnitude of the per unit fault currents are 59.464 for a bus 1 fault, 11.462 for a bus 2 fault, 72.844 for a bus 3 fault, 75.908 for a bus 4 fault, and 51.648 for a bus 5 fault. All values are higher than for the single line-to-ground case, except at bus 2 the DLG current is somewhat lower.

**9.62** For the Example 9.8 case with a second line between buses 2 and 4, the magnitude of the per unit fault currents for a single line-to-ground fault are 46.302 for a bus 1 fault, 18.234 for a bus 2 fault, 64.440 for a bus 3 fault, 56.347 for a bus 4 fault, and 42.792 for a bus 5 fault. All values are higher than for the Example 9.8 case since the extra line decreases the overall system impedance. However, the change is really only significant for the bus 2 fault.

**9.63** For the Example 9.8 case with a second generator added at bus 3, the magnitude of the per unit fault currents for a single line-to-ground fault are 48.545 for a bus 1 fault, 14.74 for a bus 2 fault, 119.322 for a bus 3 fault, 73.167 for a bus 4 fault, and 46.817 for a bus 5 fault. All values are higher than for the Example 9.8 case since the extra generator provides an additional source of fault current. The change is most dramatic for the bus 3 fault since the fault current is not limited by the step-up transformer. Of course, if a second generator were added at a location, undoubtedly a second step-up transformer would also be added.



- 9.64** For a fault at the PETE69 bus the magnitude of the per unit fault current is 15.743. The amount supplied by each of the generators is given below. During the fault 18 buses have their “a” phase voltages below 0.75 per unit. None of the “b” or “c” phases are below 0.75 per unit.

Number of Bus	Name of Bus	Phase Cur A	Phase Cur B	Phase Cur C	Phase Ang A	Phase Ang B	Phase Ang C
14	WEBER69	0.00000	0.00000	0.00000	0.00	0.00	0.00
28	JO345	1.73423	1.01826	1.91003	-49.26	-145.70	98.75
28	JO345	1.73423	1.01826	1.91003	-49.26	-145.70	98.75
31	SLACK345	3.02473	1.63361	3.02777	-62.98	-168.53	85.71
44	LAUF69	2.20862	0.31806	0.32153	-98.18	-150.41	-6.48
48	BOB69	0.00000	0.00000	0.00000	0.00	0.00	0.00
50	RODGER69	1.04501	0.34603	0.39853	-73.47	-133.62	83.58
53	BLT138	2.60139	1.11685	2.31735	-76.81	166.12	77.78
54	BLT69	7.55322	3.56570	1.81247	-95.61	-108.37	-99.90

- 9.65** For a fault at the TIM69 bus the magnitude of the per unit fault current is 10.298. The amount supplied by each of the generators is given below. During the fault 11 buses have their “a” phase voltages below 0.75 per unit. None of the “b” or “c” phases are below 0.75 per unit.

Number of Bus	Name of Bus	Phase Cur A	Phase Cur B	Phase Cur C	Phase Ang A	Phase Ang B	Phase Ang C
14	WEBER69	0.00000	0.00000	0.00000	0.00	0.00	0.00
28	JO345	1.69709	1.05349	1.87390	-46.74	-144.43	99.41
28	JO345	1.69709	1.05349	1.87390	-46.74	-144.43	99.41
31	SLACK345	2.99146	1.66554	2.99366	-61.53	-167.62	86.15
44	LAUF69	2.05014	0.51165	0.36353	-98.23	-131.93	-45.64
48	BOB69	0.00000	0.00000	0.00000	0.00	0.00	0.00
50	RODGER69	0.75872	0.38021	0.37731	-64.33	-134.86	87.71
53	BLT138	1.95108	1.25207	1.88933	-62.05	-173.73	79.94
54	BLT69	4.01092	2.66657	0.88044	-86.90	-114.05	-108.19

# Chapter 10

## System Protection

**10.1** Using Eq. (10.2.1):

$$V' = \frac{1}{n}V = \frac{345 \times 10^3}{3000} = \underline{\underline{115 \text{ V}}} \text{ (line-to-line)}$$

$$I = \frac{S_{3\phi}}{\sqrt{3} V_{LL}} = \frac{600 \times 10^6}{(\sqrt{3})(345 \times 10^3)} = 1004 \text{ A}$$

From Eq. (10.2.2),  $I_e = 0$  for zero CT error. Then, from Figure 10.7:

$$I' + I_e = I' + 0 = \frac{1}{n}I = \left(\frac{5}{1200}\right)(1004)$$

$$\underline{\underline{I' = 4.184 \text{ A}}}$$

**10.2 (a)** Step (1) –  $I' = 10 \text{ A}$

Step (2) – From Figure 10.7,

$$E' = (Z' + Z_B)I' = (0.082 + 1)(10) = 10.82 \text{ V}$$

Step (3) – From Figure 10.8,  $I_e = 0.6 \text{ A}$

Step (4) – From Figure 10.7,

$$I = \left(\frac{100}{5}\right)(10 + 0.6) = \underline{\underline{212 \text{ A}}}$$

**(b)** Step (1) –  $I' = 13 \text{ A}$

Step (2) – From Figure 10.7,

$$\begin{aligned} E' &= (Z' + Z_B)I' = (0.082 + 1.3)(13) \\ &= 18.0 \text{ V} \end{aligned}$$

Step (3) – From Figure 10.8,  $I_e = 1.8 \text{ A}$

Step (4) – From Figure 10.7,

$$I = \left(\frac{100}{5}\right)(13 + 1.8) = \underline{\underline{296 \text{ A}}}$$

(c)

$I'$	5.	8.	10.	13.	15.
$I$	105.	168.	212.	296.	700.

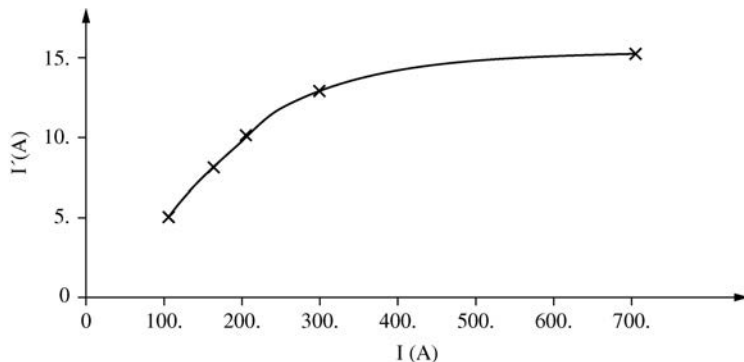

(d) With a 5-A tap setting and a minimum fault-to-pickup ratio of 2, the minimum relay trip current for reliable operation is  $I'_{min} = 2 \times 5 = 10$  A. From (a) above with  $I'_{min} = 10$  A,  $I_{min} = \underline{\underline{212}}$  A. That is, the relay will trip reliably for fault currents exceeding 212 A.

**10.3** From Figure 10.8, the secondary resistance  $Z' = 0.125 \Omega$  for the 200:5 CT.

(a) Step (1) –  $I' = 10$  A

$$\text{Step (2) – } E = (Z' + Z_B) I' = (0.125 + 1)(10) = 11.25 \text{ V}$$

Step (3) – From Figure 10.8,  $I_e = 0.18$  A

$$\text{Step (4) – } I = \left( \frac{200}{5} \right) (10 + 0.18) = \underline{\underline{407.2 \text{ A}}}$$

(b) Step (1) –  $I' = 10$  A

$$\text{Step (2) – } E = (Z' + Z_B) I' = (0.125 + 4)(10) = 41.25 \text{ V}$$

Step (3) – From Figure 10.8,  $I_e = 1.5$  A

$$\text{Step (4) – } I = \left( \frac{200}{5} \right) (10 + 1.5) = \underline{\underline{460 \text{ A}}}$$

(c) Step (1) –  $I' = 10$  A

$$\text{Step (2) – } E = (Z' + Z_B) I' = (0.125 + 5)(10) = 51.25 \text{ V}$$

Step (3) – From Figure 10.8,  $I_e = 30$  A

$$\text{Step (4) – } I = \left( \frac{200}{5} \right) (10 + 30) = \underline{\underline{1600 \text{ A}}}$$

**10.4** Note error in printing: VT should be PT.

(a)  $N_1/N_2 = 240,000/120 = 2000/1$

$$\therefore \bar{V}_{ab} = 230,000 \angle 0^\circ / 2000 = 115 \angle 0^\circ$$

$$\bar{V}_{bc} = 230,000 \angle -120^\circ / 2000 = 115 \angle -120^\circ$$

$$\bar{V}_{ca} = -(\bar{V}_{ab} + \bar{V}_{bc}) = -(115 \angle -60^\circ) = 115 \angle +120^\circ$$

(b)  $\bar{V}_{ab} = 115 \angle 0^\circ$ ; but now  $\bar{V}_{bc} = -115 \angle -120^\circ = 115 \angle 60^\circ$

$$\therefore \bar{V}_{ca} = -(\bar{V}_{ab} + \bar{V}_{bc}) = 199 \angle 150^\circ$$

The output of the PT bank is not balanced three phase.

**10.5** Designating secondary voltage as  $E_2$ , read two points on the magnetization curve ( $I_e, E_2$ ) = (1, 63) and (10, 100).

The nonlinear characteristic can be represented by the so-called Frohlich equation

$E_2 = (AI_e)/(B + I_e)$ , using that

$$63 = \frac{A}{B+1} \text{ and } 100 = \frac{10A}{B+10}$$

Solve for  $A$  and  $B$  :  $A = 107$  and  $B = 0.698$

For parts (a) and (b),  $\bar{Z}_T = (4.9 + 0.1) + j(0.5 + 0.5) = 5 + j1$

$$= 5.099 \angle 11.3^\circ \Omega$$

(a) The CT error is the percentage of mismatch between the input current (in secondary terms) denoted by  $\bar{I}'_2$  and the output current  $\bar{I}_2$  in terms of their magnitudes:

$$\text{CT error} = \frac{|\bar{I}'_2 - \bar{I}_2|}{\bar{I}_2} \times 100$$

$$E_T = I'_2 Z_T = 4(5.099) = 20.4$$

$$I_e = 20.4 / \sqrt{25 + [1 + 107 / (0.698 + I_e)]^2} = 0.163 \text{ (by iteration)}$$

From Frohlich's equation

$$E_2 = \frac{0.163(107)}{0.698 - 0.163} = 20.3$$

$$I_2 = \frac{E_2}{Z_T} = \frac{20.3}{5.099} = 3.97$$

$$\text{CT error} = \frac{0.03}{4} = 0.7\%$$

(b) For the faulted case

$$E_T = 12(5.099) = 61.2 \text{ V}; I_e = 0.894 \text{ A (by iteration)}$$

$$E_2 = 60.1 \text{ V}; I_2 = 60.1/5.099 = 11.78 \text{ A}$$

$$\text{CT error} = \frac{0.22}{12} \times 100 = 1.8\%$$

(c) For the higher burden,  $\bar{Z}_T = 15 + j2 = 15.13 \angle 7.6^\circ \Omega$

For the given load condition,  $E_T = 4(13.13) = 60.5 \text{ V}$

$$I_e = 0.814 \text{ A}; E_2 = 57.6 \text{ V}; I_2 = \frac{57.6}{15.13} = 3.81 \text{ A}$$

$$\therefore \text{CT error} = \frac{0.19}{4} \times 100 = 4.8\%$$

(d) For the fault condition,  $E_T = 181.6 \text{ V}; I_e = 9.21 \text{ A};$

$$E_2 = 99.5 \text{ V}; I_2 = \frac{99.5}{15.13} = 6.58 \text{ A}$$

$$\therefore \text{CT error} = \frac{5.42}{12} \times 100 = 45.2\%$$

Thus, CT error increases with increasing CT current and is further increased by the high terminating impedance.

**10.6** Assuming the CT to be ideal,  $I_2$  would be 12 A; the device would detect the 1200-A primary current (or any fault current down to 800 A) independent of  $\bar{Z}_L$ .

(a) In the solution of Prob. 10.5(b),  $I_2 = 11.78 \text{ A}$ .

Therefore, the fault is detected.

(b) In Prob. 10.5(d),  $I_2 = 6.58 \text{ A}$ .

The fault is then not detected. The assumption that the CT was ideal in this case would have resulted in failing to detect a faulted system.

**10.7** (a) The current tap setting (pickup current) is  $I_p = 1.0 \text{ A}$ .

$$\frac{I'}{I_p} = \frac{10}{1} = 10. \text{ From curve } \frac{1}{2} \text{ in Figure 10.12}$$

$$t_{\text{operating}} = \underline{0.08} \text{ s}$$

(b)  $\frac{I'}{I_p} = \frac{10}{2} = 5$ . Interpolating between curve 1 and curve 2 in Figure 10.12,  $t_{\text{operating}} = \underline{0.55} \text{ s}$

(c)  $\frac{I'}{I_p} = \frac{10}{2} = 5$ . From curve 7,  $t_{\text{operating}} = \underline{3} \text{ s}$

(d)  $\frac{I'}{I_p} = \frac{10}{3} = 3.33$  From curve 7,  $t_{operating} = \underline{5.2 \text{ s}}$

(e)  $\frac{I'}{I_p} = \frac{10}{12} < 1$ . The relay does not operate. It remains in the blocking position.

**10.8** From the plot of  $I'$  vs  $I$  in Problem 10.2(c),  $I' = 14.5 \text{ A}$ .  $\frac{I'}{I_p} = \frac{14.5}{5} = 2.9$

From curve 4 in Figure 10.12,  $t_{operating} = \underline{3.7 \text{ s}}$

**10.9 (a)**  $\tau = RC = 1 \text{ s}$

$v_0 = 2(1 - e^{-t})$ ; at  $t = T_{delay}$ ,  $V_0 = 1$

$\therefore 1 - e^{-T_{delay}} = 0.5$  or  $e^{T_{delay}} = 2$

Thus  $T_{delay} = \ln 2 = 0.693 \text{ s}$

**(b)**  $\tau = RC = 10 \text{ s}$

$v_0 = 2(1 - e^{-t/10})$ ; at  $t = T_{delay}$ ,  $V_0 = 1$

$\therefore e^{T_{delay}/10} = 2$  or  $T_{delay}/10 = \ln 2$

Thus  $T_{delay} = 6.93 \text{ s}$

The circuit time response is sketched below:

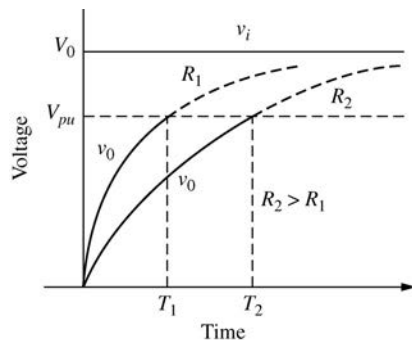

**10.10** From the solution of Prob. 10.5(b),  $I_2 = I_{relay} = 11.78 \text{ A}$

$\frac{I_{relay}}{I_{pickup}} = \frac{11.78}{5} = 2.36$  corresponding to which, from curve 2,  $T_{operating} = 1.2 \text{ s}$

**10.11 (a)** For the 700. A fault current at bus 3, fault-to-pickup current ratios and relay operating times are:

B3:  $\frac{I'_{3,fault}}{TS3} = \frac{700/(200/5)}{3} = \frac{17.5}{3} = 5.83$

From curve 1/2 of Figure 10.12,  $t_{operating3} = 0.10$  seconds. Adding the breaker operating time, primary protection clears this fault in  $(0.10 + 0.083) = 0.183$  seconds.

$$B2: \frac{I'_{2\text{fault}}}{TS2} = \frac{700/(200/5)}{5} = \frac{17.5}{5} = 3.5$$

From curve 2 in Figure 10.12,  $t_{operating2} = 1.3$  seconds. The coordination time interval between B3 and B2 is  $(1.3 - 0.183) = 1.12$  seconds.

(b) For the 1500-A fault current at bus 2:

$$B2: \frac{I'_{2\text{fault}}}{TS2} = \frac{1500/(200/5)}{5} = \frac{37.5}{5} = 7.5$$

From curve 2 of Figure 10.12,  $t_{operating2} = 0.55$  seconds. Adding the breaker operating time, primary protection clears this fault in  $(0.55 + 0.083) = 0.633$  seconds.

$$B1: \frac{I'_{1\text{fault}}}{TS1} = \frac{1500/(400/5)}{5} = \frac{18.75}{5} = 3.75$$

From curve 3 of Figure 10.12,  $t_{operating1} = 1.8$  seconds. The coordination time interval between B2 and B1 is  $(1.8 - 0.633) = 1.17$  seconds.

Fault-to-pickup ratios are all  $> 2.0$

Coordination time intervals are all  $> 0.3$  seconds.

**10.12** First select current Tap settings (*TSs*). Starting at B3, the primary and secondary CT currents for maximum load *L3* are:

$$I_{L3} = \frac{S_{L3}}{V_3 \sqrt{3}} = \frac{9 \times 10^6}{34.5 \times 10^3 \sqrt{3}} = 150.6 \text{ A}$$

$$I'_{L3} = \frac{150.6}{(200/5)} = 3.77 \text{ A}$$

From Figure 10.12, select 4-A *TS3*, which is the lowest *TS* above 3.77 A.

$$I_{L2} = \frac{(S_{L2} + S_{L3})}{V_2 \sqrt{3}} = \frac{(9.0 + 9.0) \times 10^6}{34.5 \times 10^3 \sqrt{3}} = 301.2 \text{ A}$$

$$I'_{L2} = \frac{301.2}{(400/5)} = 3.77 \text{ A}$$

Again, select 4-A *TS2* for B2.

$$I_{L1} = \frac{S_{L1} + S_{L2} + S_{L3}}{V_1 \sqrt{3}} = \frac{(9 + 9 + 9) \times 10^6}{34.5 \times 10^3 \sqrt{3}} = 451.8 \text{ A}$$

$$I'_{L1} = \frac{451.8}{(600/5)} = 3.77$$

Again select a 4 A  $TS1$  for B1. Next select Time Dial Settings ( $TDS$ s). Starting at B3, the largest fault current through B3 is 3000 A, for the maximum fault at bus 2 (just to the right of B3). The fault to pickup ratio at B3 for this fault is

$$\frac{I'_{3\text{fault}}}{TS3} = \frac{3000/(200/5)}{4} = 18.75$$

Select  $TDS = \frac{1}{2}$  at B3, in order to clear this fault as rapidly as possible. Then from curve  $\frac{1}{2}$  in Fig. 10.12,  $t_{\text{operating}3} = 0.05$  s. Adding the breaker operating time (5 cycles = 0.083 s), primary protection clears this fault in  $0.05 + 0.083 = 0.133$  s.

For this same fault, the fault-to-pickup ratio at B2 is

$$\frac{I'_{2\text{fault}}}{TS2} = \frac{3000/(400/5)}{4} = \frac{37.5}{4} = 9.4$$

Adding B3 relay operating time, breaker operating time, and 0.3 s coordination interval,  $(0.05 + 0.083 + 0.3) = 0.433$  s, which is the desired B2 relay operating time. From Figure 10.12, select  $TDS2 = 2$ .

Next select the  $TDS$  at B1. The largest fault current through B2 is 5000 A, for the maximum fault at bus 1 (just to the right of B2). The fault-to-pickup ratio at B2 for this fault is

$$\frac{I'_{2\text{fault}}}{TS2} = \frac{5000/(400/5)}{4} = \frac{62.5}{4} = 15.6$$

From curve 2 in Fig. 10.12, the relay operating time is 0.38 s. Adding the 0.083 s breaker operating time and 0.3 s coordination time interval, we want a B1 relay operating time of  $(0.38 + 0.083 + 0.3) = 0.763$  s. Also, for this same fault,

$$\frac{I'_{1\text{fault}}}{TS1} = \frac{5000/(600/5)}{4} = \frac{41.66}{4} = 10.4$$

From Fig. 10.12, select  $TDS1 = 3.5$ .

Breaker	Relay	$TS$	$TDS$
B1	CO-8	4	3.5
B2	CO-8	4	2
B3	CO-8	4	$\frac{1}{2}$

Solution Problem 10.7

- 10.13** For the 1500-A fault current at bus 3, fault-to-pickup current ratios and relay operating times are:

$$\text{B3: } \frac{I'_{3\text{fault}}}{TS3} = \frac{1500/(200/5)}{4} = \frac{37.5}{4} = 9.4$$

From curve  $\frac{1}{2}$  of Figure 10.12,  $t_{\text{operating}3} = 0.08$  s. Adding breaker operating time, primary relaying clears this fault in  $0.08 + 0.083 = 0.163$  s.

$$\text{B2: } \frac{I'_{2\text{fault}}}{TS2} = \frac{1500/(400/5)}{4} = \frac{18.75}{4} = 4.7$$



From curve 2 in Fig. 10.12,  $t_{operating2} = 0.85$  s. The coordination time interval between B3 and B2 is  $(0.85 - 0.163) = 0.69$  s.

$$B1: \frac{I'_{1fault}}{TS1} = \frac{1500/(600/5)}{4} = \frac{12.5}{4} = 3.1$$

From curve 3.5 in Fig. 10.12,  $t_{operating1} = 2.8$  s. The coordination time interval between B3 and B1 is  $(2.8 - 0.163) = 2.6$  s.

For the 2250-A fault current at bus 2, fault-to-pickup current ratios and relay operating times are:

$$B2: \frac{I'_{2fault}}{TS2} = \frac{2250/(400/5)}{4} = \frac{28.13}{4} = 7.0$$

From curve 2 in Fig. 10.12,  $t_{operating2} = 0.6$  s.

Adding breaker operating time, primary protection clears this fault in  $(0.6 + 0.083) = 0.683$  s.

$$B1: \frac{I'_{1fault}}{TS1} = \frac{2250/(600/5)}{4} = \frac{18.75}{4} = 4.7$$

From curve 3.5 in Fig. 10.12,  $t_{operating1} = 1.5$  s. The coordination time interval between B2 and B1 is  $(1.5 - 0.683) = 0.82$  s.

Fault-to-pickup ratios are all  $> 2.0$

Coordination time intervals are all  $> 0.3$  s

#### 10.14 The load currents are calculated as

$$\begin{aligned} I_1 &= \frac{4 \times 10^6}{\sqrt{3}(11 \times 10^3)} = 209.95 \text{ A}; I_2 = \frac{2.5 \times 10^6}{\sqrt{3}(11 \times 10^3)} \\ &= 131.22 \text{ A}; I_3 = \frac{6.75 \times 10^6}{\sqrt{3}(11 \times 10^3)} = 354.28 \text{ A} \end{aligned}$$

The normal currents through the sections are then given by

$$I_{21} = I_1 = 209.95 \text{ A}; I_{32} = I_{21} + I_2 = 341.16 \text{ A}; I_s = I_{32} + I_3 = 695.44 \text{ A}$$

With the given CT ratios, the normal relay currents are

$$i_{21} = \frac{209.95}{(200/5)} = 5.25 \text{ A}; i_{32} = \frac{341.16}{(200/5)} = 8.53 \text{ A}; i_s = \frac{695.44}{(400/5)} = 8.69 \text{ A}$$

Now obtain CTS (Current Tap Settings) or pickup current in such a way that the relay does not trip under normal currents. For this type of relay, CTS available are 4, 5, 6, 7, 8, 10, and 12 A. For position 1, the normal current in the relay is 5.25 A; so choose  $(CTS)_1 = 6$  A.

Choosing the nearest setting higher than the normal current. For position 2, normal current being 8.53 A, choose  $(CTS)_2 = 10$  A. For position 3, normal current being 8.69 A, choose  $(CTS)_3 = 10$  A. Next, select the intentional delay indicated by  $TDS$ , time dial setting. Utilize the short-circuit currents to coordinate the relays.

The current in the relay at 1 on short circuit is  $i_{SC1} = \frac{2500}{(200/5)} = 62.5$  A expressed as a multiple of the  $CTS$  or pickup value,

$$\frac{i_{SC1}}{(CTS)_1} = \frac{62.5}{6} = 10.42$$

Choose the lowest  $TDS$  for this relay for fastest action.

$$\text{Thus } (TDS)_1 = \frac{1}{2}$$

Referring to the relay characteristic, the operating time for relay 1 for a fault at 1 is obtained as  $T_{11} = 0.15$  s.

To set the relay at 2 responding to a fault at 1, allow 0.15 for breaker operation and an error margin of 0.3 s in addition to  $T_{11}$ .

$$\text{Thus } T_{21} = T_{11} + 0.1 + 0.3 = 0.55 \text{ s}$$

Short circuit for a fault at 1 as a multiple of the  $CTS$  at 2 is

$$\frac{i_{SC1}}{(CTS)_2} = \frac{62.5}{10} = 6.25$$

From the characteristics for 0.55 s operating time and 6.25 ratio,

$$(TDS)_2 = 2$$

Now, setting the relay at 3:

For a fault at bus 2, the short-circuit current is 3000 A, for which relay 2 responds in a time  $T_{22}$  calculated as

$$\frac{i_{SC2}}{(CTS)_2} = \frac{3000}{(200/5)10} = 7.5$$

For  $(TDS)_2 = 2$ , from the relay characteristic,  $T_{22} = 0.5$  s. Allowing the same margin for relay 3 to respond for a fault at 2, as for relay 2 responding to a fault at 1,

$$T_{32} = T_{22} + 0.1 + 0.3 = 0.9 \text{ s}$$

The current in the relay expressed as a multiple of pickup is

$$\frac{i_{sc2}}{(CTS)_3} = \frac{3000}{(400/5)10} = 3.75$$

Thus, for  $T_3 = 0.9$  s, and the above ratio, from the relay characteristic

$$(TDS)_3 = 2.5$$

Note: Calculations here did not account for higher load starting currents that can be as high as 5 to 7 times rated values.

**10.15 (a)** Three-phase permanent fault on the load side of bus 3.

From Table 10.7, the three-phase fault current at bus 3 is 2000 A. From Figure 10.19, the 560 A fast recloser opens 0.04 s after the 2000 A fault occurs, then recloses  $\frac{1}{2}$  s later into the permanent fault, opens again after 0.04 s, and recloses into the fault a second time after a 2 s delay. Then the 560 A delayed recloser opens 1.5 s later. During this time interval, the 100 T fuse clears the fault. The delayed recloser then recloses 5 to 10 s later, restoring service to loads 1 and 2.

**(b)** Single line-to-ground permanent fault at bus 4 on the load side of the recloser. From Table 10.7, the IL-G fault current at bus 4 is 2600 A. From Figure 10.19, the 280 A fast recloser (ground unit) opens after 0.034 s, recloses  $\frac{1}{2}$  s later into the permanent fault, opens again after 0.034 s, and recloses a second time after a 2 s delay. Then the 280 A delayed recloser (ground unit) opens 0.7 s later, recloses 5 to 10 s later, then opens again after 0.7 s and permanently locks out.

**(c)** Three-phase permanent fault at bus 4 on the source side of the recloser. From Table 10.7, the three-phase fault at bus 4 is 3000 A. From Figure 10.19, the phase overcurrent relay trips after 0.95 s, thereby energizing the circuit breaker trip coil, causing the breaker to open.

**10.16** Load current =  $\frac{4000}{\sqrt{3}(34.5)} = 66.9$  A ; max. fault current = 1000 A; min. fault current = 500 A

**(a)** For this condition, the recloser must open before the fuse melts. The maximum clearing time for the recloser should be less than the minimum melting time for the fuse at a current of 500 A. Referring to Fig. 10.43, the maximum clearing time for the recloser is about 0.135 s.

**(b)** For this condition, the minimum clearing time for the recloser should be greater than the maximum clearing time for the fuse at a current of 1000 A. Referring to Fig. 10.43, the minimum clearing time is about 0.056 s.

**10.17 (a)** For a fault of  $P_1$ , only breakers B34 and B43 operate; the other breakers do not operate. B23 should coordinate with B34 so that B34 operates before B23 (and before B12, and before B1). Also, B4 should coordinate with B43 so that B43 operates before B4.

**(b)** For a fault of  $P_2$ , only breakers B23 and B32 operate; the other breakers do not operate. B12 should coordinate with B23 so that B23 operates before B12 (and before B1). Also B43 should coordinate with B32 so that B32 operates before B43 (and before B4).

- (c) For a fault of  $P_3$ , only breakers B12 and B21 operate; the other breakers do not operate. B32 should coordinate with B21 so that B21 operates before B32 (and before B43, and before B4). Also, B1 should coordinate with B12 so that B12 operates before B1.

(d)

Fault Bus	Operating Breakers
1	B1 and B21
2	B12 and B32
3	B23 and B43
4	B4 and B34

### 10.18

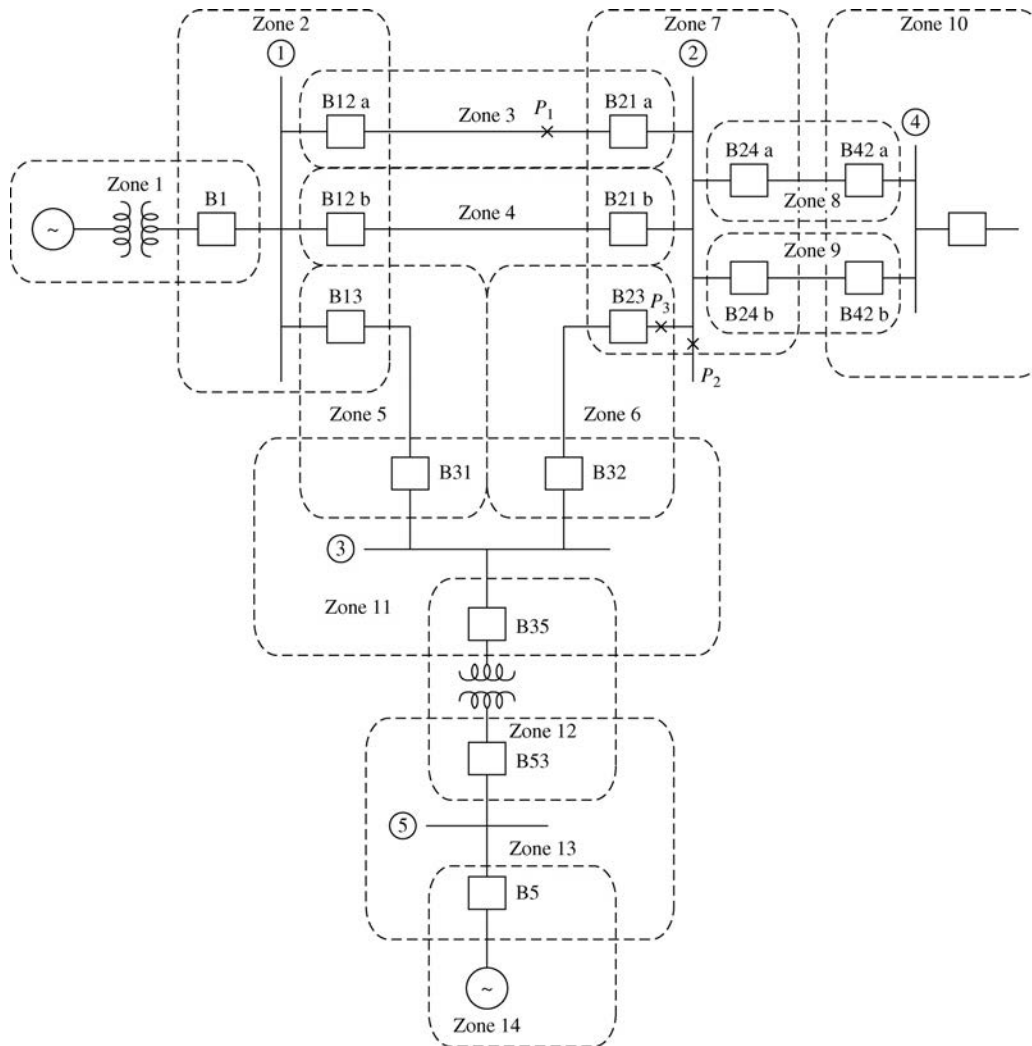

- (a) For a fault at  $P_1$ , breakers in zone 3 operate (B12a and B21a).  
 (b) For a fault at  $P_2$ , breakers in zone 7 operate (B21a, B21b, B23, B24a, B24b).  
 (c) For a fault at  $P_3$ , breakers in zone 6 and zone 7 operate (B23, B32, B21a, B21b, B24a, and B24b).

10.19 (a)

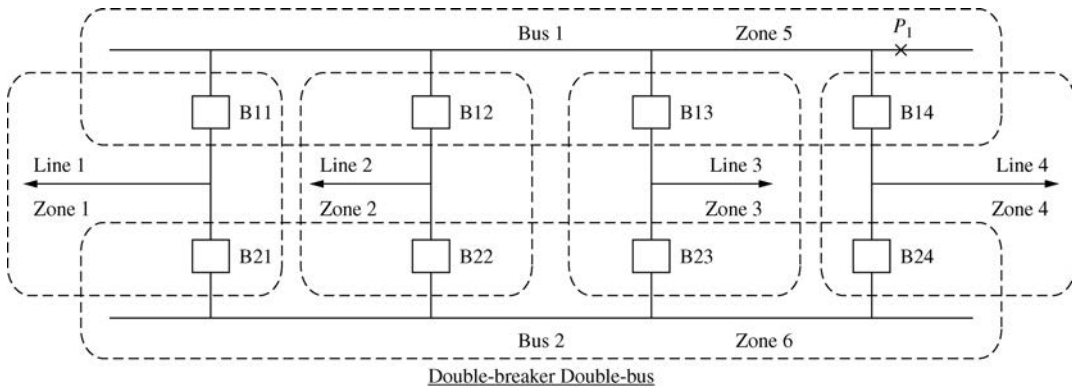
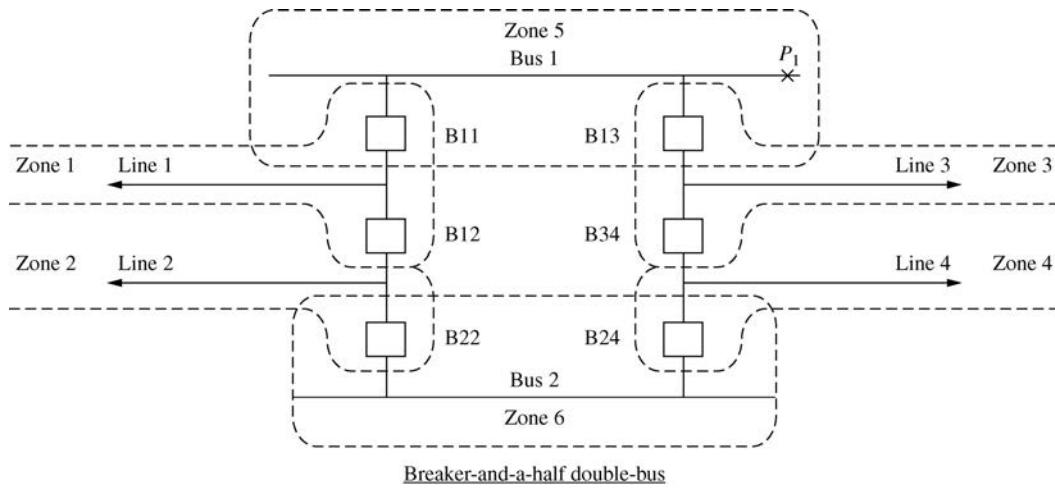
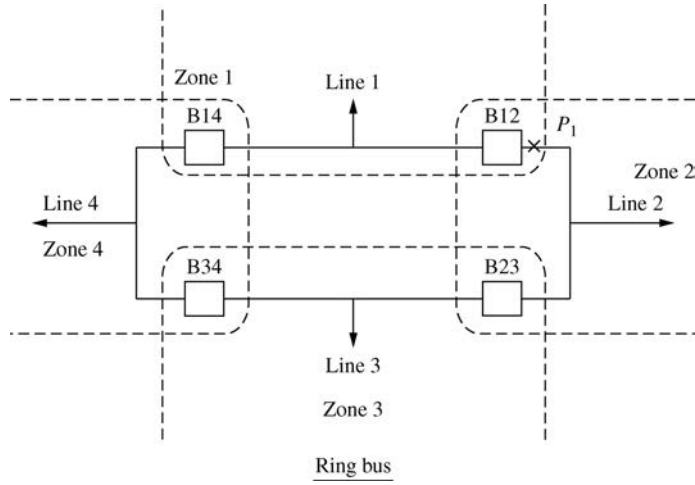

(b)

Scheme	Breakers that open for fault on Line 1
Ring Bus	B12 and B14
Breaker- and ½, Double Bus	B11 and B12
Double Breaker, Double Bus	B11 and B21

(c)

Scheme	Lines Removed for a Fault at P1
Ring Bus	Line 1 and Line 2
Breaker- and ½, Double Bus	None
Double Breaker, Double Bus	None

(d)

Scheme	Breakers that open for a Fault on Line 1 with Stuck Breaker
Ring Bus	B12, B14 and either B23 or B34
Breaker- and ½, Double Bus	B11, B12 and either B13 or B22
Double Breaker, Double Bus	B11, B21 and all other breakers on bus 1 or bus 2.

$$10.20 \text{ (a)} \quad \bar{Z}' = \frac{V'_{LN}}{I'_L} = \frac{V_{LN}/(4500/1)}{I_L/(1500/5)} = \left( \frac{V_{LN}}{I_L} \right) \frac{1}{15}$$

$$\bar{Z}' = \frac{\bar{Z}}{15}$$

Set the B12 zone 1 relay for 80% reach of line 1–2:

$$Z_{r1} = 0.8(6 + j60)/15 = \underline{0.32 + j3.2} \Omega \text{ secondary}$$

Set the B12 zone 2 relay for 120% reach of line 1–2:

$$Z_{r2} = 1.2(6 + j60)/15 = \underline{0.48 + j4.8} \Omega \text{ secondary}$$

Set the B12 zone 3 relay for 100% reach of line 1–2 and 120% reach of line 2–3:

$$Z_{r3} = 1.0(6 + j60)/15 + 1.2(5 + j50)/15 = \underline{0.8 + j8.0} \Omega \text{ secondary}$$

(b) The secondary impedance viewed by B12 during emergency loading is:

$$\bar{Z}' = \left( \frac{\bar{V}_{LN}}{\bar{I}_L} \right) \left( \frac{1}{15} \right) = \left( \frac{\frac{500}{\sqrt{3}} \angle 0^\circ}{1.4 \angle -\cos^{-1} 0.9} \right) \frac{1}{15} = 13.7 \angle 25.8^\circ \Omega$$

$\bar{Z}'$  exceeds the zone 3 setting of  $(0.8 + j8.0) = 8.04 \angle 84.3^\circ \Omega$  for B12. Hence, the impedance during emergency loading lies outside the trip region of this 3-zone mho relay (see Figure 10.29 (b)).

- 10.21 (a) For the bolted three-phase fault at bus 4, the apparent primary impedance seen by the B12 relay is:

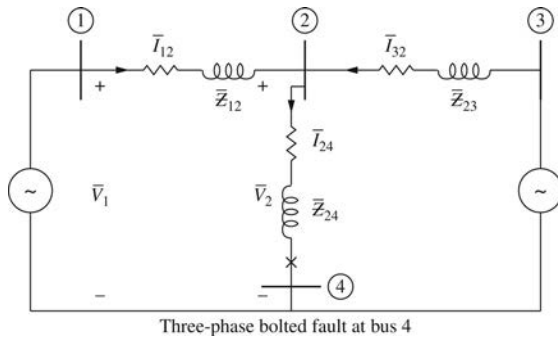

$$\bar{Z}_{\text{apparent}} = \frac{\bar{V}_1}{\bar{I}_{12}} = \frac{\bar{V}_1 - \bar{V}_2 + \bar{V}_2}{\bar{I}_{12}} = \frac{(\bar{V}_1 - \bar{V}_2)}{\underbrace{\bar{I}_{12}}_{\bar{Z}_{12}}} + \frac{\bar{V}_2}{\bar{I}_{12}}$$

$$\bar{Z}_{\text{apparent}} = \bar{Z}_{12} + \frac{\bar{V}_2}{\bar{I}_{12}}$$

Using  $\bar{V}_2 = \bar{Z}_{24}\bar{I}_{24}$  and  $\bar{I}_{24} = \bar{I}_{12} + \bar{I}_{32}$ :

$$\bar{Z}_{\text{apparent}} = \bar{Z}_{12} + \frac{\bar{Z}_{24}(\bar{I}_{12} + \bar{I}_{32})}{\bar{I}_{12}} = \bar{Z}_{12} + \bar{Z}_{24} + \left(\frac{\bar{I}_{32}}{\bar{I}_{12}}\right)\bar{Z}_{24} \text{ which is the desired result.}$$

- (b) The apparent secondary impedance seen by the B12 relay. For the bolted three-phase fault at bus 4 is:

$$\bar{Z}'_{\text{apparent}} = \frac{\bar{Z}_{\text{apparent}}}{(n_v/n_l)} = \frac{(3 + j40) + (6 + j80) + \left(\frac{\bar{I}_{32}}{\bar{I}_{12}}\right)(6 + j80)}{(n_v/n_l)}$$

$$\bar{Z}'_{\text{apparent}} = \frac{\left[9 + 6\left(\frac{\bar{I}_{32}}{\bar{I}_{12}}\right)\right] + j\left[120 + 80\left(\frac{\bar{I}_{32}}{\bar{I}_{12}}\right)\right]}{(n_v/n_l)} \Omega$$

where  $n_v$  is the VT ratio and  $n_l$  is the CT ratio. Also, the B12 zone 3 relay is set with a secondary impedance:

$$\bar{Z}'_{r3} = \frac{(3 + j40) + 1.2(6 + j80)}{(n_v/n_l)} = \frac{10.2 + j136}{(n_v/n_l)} \Omega \text{ secondary}$$

Comparing  $\bar{Z}_{r3}$  with  $\bar{Z}'_{apparent}$ ,  $\bar{Z}'_{apparent}$  exceeds  $\bar{Z}_{r3}$  when  $(\bar{I}_{32} / \bar{I}_{12}) > 0.2$ . Hence  $\bar{Z}'_{apparent}$  lies outside the trip region for the three-phase fault at bus 4 when  $(\bar{I}_{32} / \bar{I}_{12}) > 0.2$ ; remote backup of line 2–4 at B12 is then ineffective.

$$10.22 \quad R_r = \frac{(1)^2 2}{(2^2 + 0.8^2)} = 0.431 \text{ p.u.}; \quad X_r = \frac{(1)^2 0.8}{(2^2 + 0.8^2)} = 0.1724 \text{ p.u.}$$

The X–R diagram is given below:

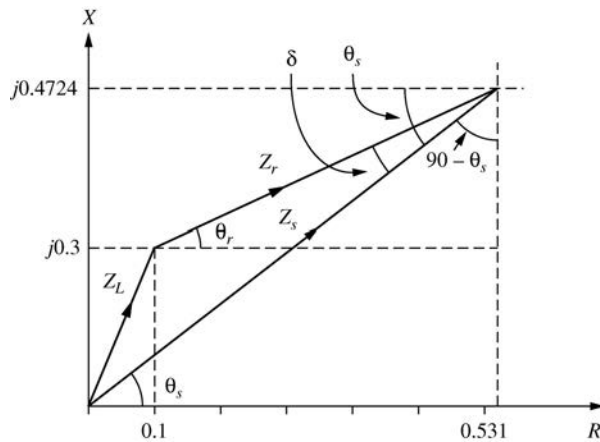

Based on the diagram,  $\bar{Z}_S$  can be obtained analytically or graphically:

$$\begin{aligned} \bar{Z}_S &= \bar{Z}_L + \bar{Z}_r = (0.1 + 0.431) + j(0.3 + 0.1724) \\ &= 0.7107 \angle 41.66^\circ \end{aligned}$$

$$\begin{aligned} \delta &= \theta_s - \theta_r = 41.66^\circ - \tan^{-1} \left( \frac{0.1724}{0.431} \right) \\ &= 41.66^\circ - 22^\circ \\ &= 19.66^\circ \end{aligned}$$

10.23 (a) Given the reaches,

$$\text{Zone 1: } \bar{Z}_r = 0.1 \times 80\% = 0.08;$$

$$\text{Zone 2: } 0.1 \times 120\%$$

$$= 0.12;$$

$$\text{Zone 3: } 0.1 \times 230\% = 0.25$$

In the view of the system symmetry, all six sets of relays have identical settings.

(b) It should be given in the problem statement that the system is the same as Prob. 9.11.

$$V_{LN \text{ base}} = \frac{230}{\sqrt{3}} = 133 \text{ kV}; \quad I_{L \text{ base}} = \frac{100}{0.23\sqrt{3}} = 251 \text{ A}$$



The equivalent instrument transformer's secondary quantities are

$$V_{base} = 133 \left( \frac{115}{133} \right) = 115 \text{ V}; I_{base} = 251 \left( \frac{5}{400} \right) = 3.14 \text{ A}$$

$$\therefore Z_{base} = 115 / 3.14 = 36.7 \Omega$$

∴ The settings are (by multiplying by 36.7)

Zone 1: 2.93 Ω; Zone 2: 4.40 Ω; Zone 3: 9.16 Ω

- (c) The operating region for three zone distance relay with directional restraint as per the arrangement of Fig. 10.50 is shown below:

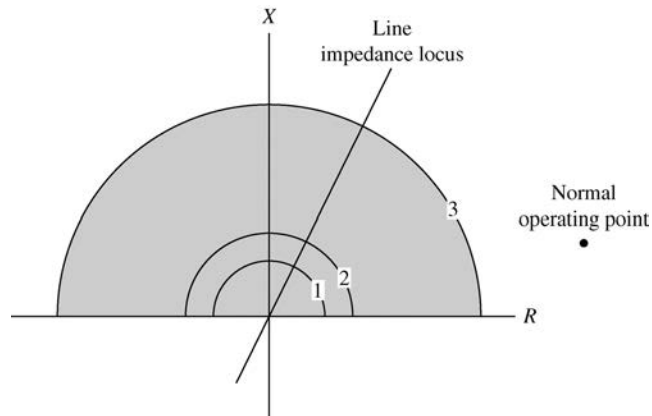

Locate Point X on the diagram.

Comment on line breaker operations:

B31: Fault in Zone 1; instantaneous operation

B32: Directional unit should block operation

B23: Fault in Zone 2; delayed operation

B31 should trip first, preventing B23 from tripping.

B21: Fault duty is light. Fault in Zone 3, if detected at all.

B12: Directional unit should block operation.

B13: Fault in Zone 2; just outside of Zone 1; delayed operation

Line breakers B13 and B31 clear the fault as desired. In addition, breakers B1 and B4 must be coordinated with B13 so that the trip sequence is B13, B1, and B4 from fastest to slowest. Likewise, B13, B31, and B23 should be faster than B2 and B5.

**10.24** For a 20% mismatch between  $I'_1$  and  $I'_2$ , select a 1.20 upper slope in Figure 10.34. That is:

$$\frac{2+k}{2-k} = 1.20$$

Solving,  $k = 0.1818$

**10.25 (a)** Output voltages are given by

$$\bar{V}_1 = jX_m \bar{I}_1 = j5(-j16) = 80 \text{ V}$$

$$\bar{V}_2 = jX_m \bar{I}_2 = j5(-j7) = 35 \text{ V}$$

$$\bar{V}_3 = jX_m \bar{I}_3 = j5(j36) = -180 \text{ V}$$

$$\bar{V}_4 = jX_m \bar{I}_4 = j5(-j13) = 65 \text{ V}$$

$$\therefore \bar{V}_0 = \bar{V}_1 + \bar{V}_2 + \bar{V}_3 + \bar{V}_4 = 80 + 35 - 180 + 65 = 0$$

Thus there is no voltage to operate the voltage relay *VR*. For the external fault on line 3, voltages and currents are shown below:

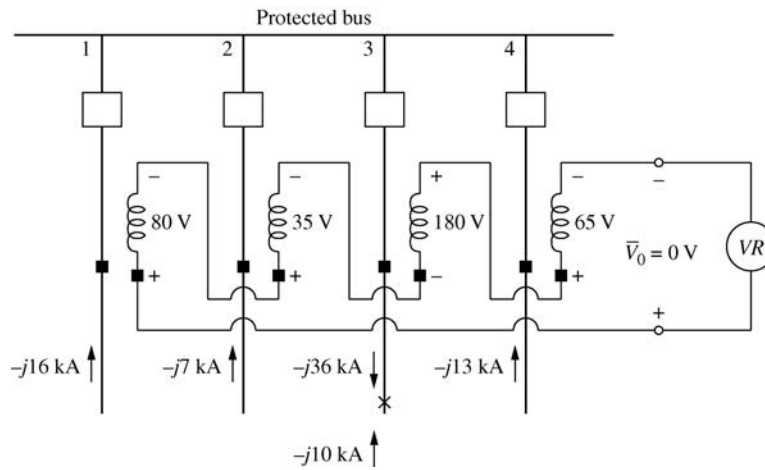

**(b)** Moving the fault location to the bus, as shown below, the fault currents and corresponding voltages are indicated. Now  $V_0 = 80 + 35 + 50 + 65 = 230 \text{ V}$  and the voltage relay *VR* will trip all four line breakers to clear the fault.

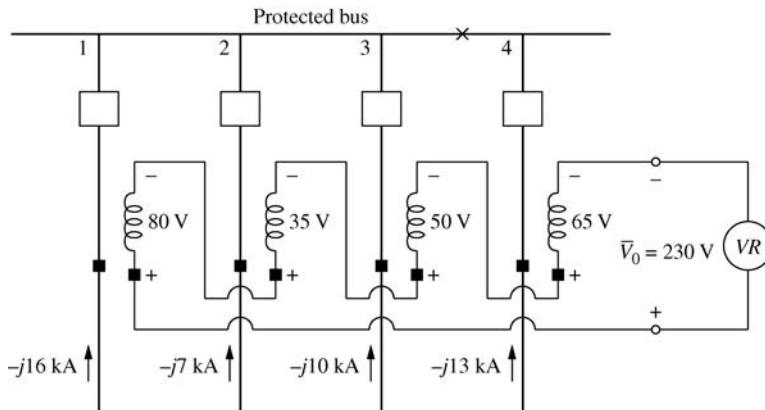

- (c) By moving the external fault from line 3 to a corresponding point  
 (i) On Line 2

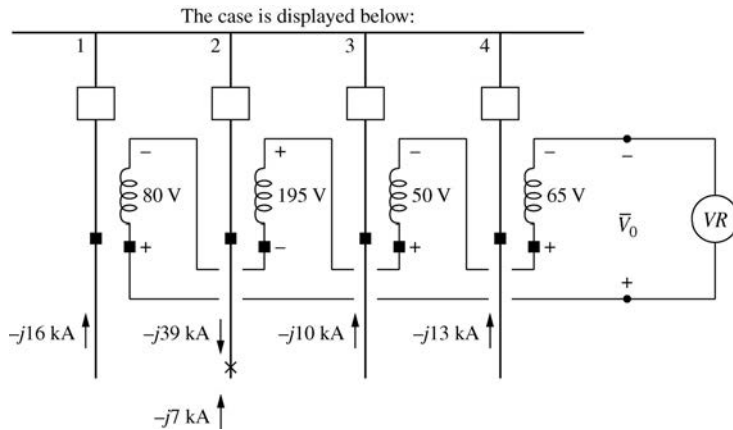

$$\text{Here } V_0 = 80 - 195 + 50 + 65 = 0$$

VR would not operate.

- (ii) On Line 4

This case is displayed below:

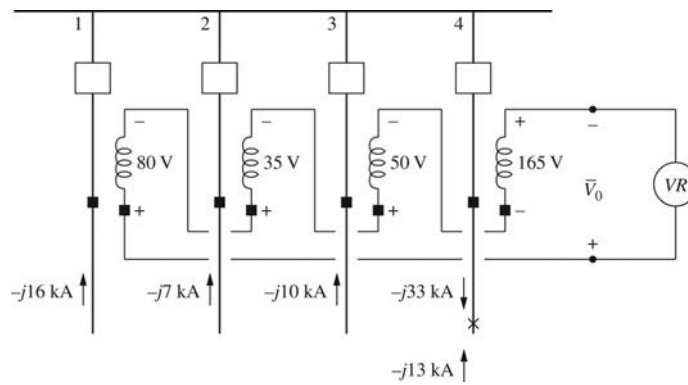

$$\text{Here } V_0 = 80 + 35 + 50 - 165 = 0$$

VR would not operate.

**10.26** First select CT ratios. The transformer rated primary current is:

$$I_{1 \text{ rated}} = \frac{5 \times 10^6}{20 \times 10^3} = 250 \text{ A}$$

From Table 10.2, select a 300:5 CT ratio on the 20 kV (primary) side to give

$I'_1 = (250)(5/300) = 4.167 \text{ A}$  at rated conditions. Similarly:

$$I_{2 \text{ rated}} = \frac{5 \times 10^6}{8.66 \times 10^3} = 577.4 \text{ A}$$

Select a 600:5 secondary CT ratio so that  $I'_2 = (577.4)(5/600) = 4.811 \text{ A}$  at rated conditions.

Next, select relay taps to balance currents in the restraining windings. The ratio of currents in the restraining windings is:

$$\frac{I'_2}{I'_1} = \frac{4.811}{4.167} = 1.155$$

The closest relay tap ratio is  $T'_2/T'_1 = \underline{1.10}$ .

The percentage mismatch for this tap setting is:

$$\begin{aligned} \% \text{ Mismatch} &= \left| \frac{(I'_1/T'_1) - (I'_2/T'_2)}{(I'_2/T'_2)} \right| \times 100 = \left| \frac{\left(\frac{4.167}{5}\right) - \left(\frac{4.811}{5.5}\right)}{\left(\frac{4.811}{5}\right)} \right| \times 100 \\ &= \underline{4.7\%} \end{aligned}$$

**10.27** Connect CTs in  $\Delta$  on the 500 kV  $Y$  side, and in  $Y$  on the 345 kV  $\Delta$  side of the transformer.

Rated current on the 345 kV  $\Delta$  side is

$$I_{a \text{ rated}} = \frac{500 \times 10^6}{345 \times 10^3 \sqrt{3}} = 836.7 \text{ A}$$

Select a  $\underline{900:5}$  CT ratio on the 345 kV  $\Delta$  side to give  $I'_a = (836.7)(5/900) = 4.649 \text{ A}$  at rated conditions in the CT secondaries and in the restraining windings.

Similarly, rated current on the 500 kV  $Y$  side is

$$I_{A \text{ rated}} = \frac{500 \times 10^6}{500 \times 10^3 \sqrt{3}} = 577.4 \text{ A}$$

Select a  $\underline{600:5}$  CT ratio on the 500 kV  $Y$  side to give  $I'_A = (577.4)(5/600) = 4.811 \text{ A}$  in the 500 kV CT secondaries and  $I'_{AB} = 4.811\sqrt{3} = 8.333 \text{ A}$  in the restraining windings.

Next, select relay taps to balance currents in the restraining windings.

$$\frac{I'_{AB}}{I'_a} = \frac{8.333}{4.649} = 1.79$$

The closest tap ratio is  $T'_{AB}/T'_a = \underline{1.8}$

For a tap setting of  $\underline{5:9}$ . The percentage mismatch for this relay tap setting is:

$$\begin{aligned} \% \text{ Mismatch} &= \left| \frac{(I'_{AB}/T'_{AB}) - (I'_a/T'_a)}{(I'_a/T'_a)} \right| \times 100 = \left| \frac{(8.333/9) - (4.649/5)}{(4.649/5)} \right| \times 100 \\ &= \underline{0.4\%} \end{aligned}$$

**10.28** The primary line current is  $\frac{15 \times 10^6}{\sqrt{3}(33 \times 10^3)} = 262.43 \text{ A}$  (say  $I_p$ )

The secondary line current is  $262.43 \times 3 = 787.3 \text{ A}$  (say  $I_r$ )

The CT current on the primary side is  $i_p = 262.43 \left( \frac{5}{300} \right) = 4.37 \text{ A}$

The CT current on the secondary side is  $i_s = 787.3 \left( \frac{5}{2000} \right) \sqrt{3} = 3.41 \text{ A}$

[Note:  $\sqrt{3}$  is applied to get the value on the line side of  $\Delta$ -connected CTs.]

The relay current under normal load is

$$i_r = i_p - i_s = 4.37 - 3.41 = 0.96 \text{ A}$$

With 1.25 overload ratio, the relay setting should be

$$i_r = 1.25(0.96) = 1.2 \text{ A}$$

**10.29** The primary line current is  $I_p = \frac{30 \times 10^6}{\sqrt{3}(33 \times 10^3)} = 524.88 \text{ A}$

Secondary line current is  $I_s = 3I_p = 1574.64 \text{ A}$

The CT current on the primary side is  $I_1 = 524.88 \left( \frac{5}{500} \right) = 5.25 \text{ A}$

And that on the secondary side is  $I_2 = 1574.64 \left( \frac{5}{2000} \right) \sqrt{3} = 6.82 \text{ A}$

Relay current at 200% of the rated current is then

$$2(I_2 - I_1) = 2(6.82 - 5.25) = 3.14 \text{ A}$$

**10.30** Line currents are:  $I_\Delta = \frac{15 \times 10^6}{\sqrt{3}(33 \times 10^3)} = 262.44 \text{ A}$

$$I_Y = \frac{15 \times 10^6}{\sqrt{3}(11 \times 10^3)} = 787.3 \text{ A}$$

If the CT's on HV-side are connected in Y, then the CT ratio on the HV-side is  $787.3/5 = 157.46$

Similarly, the CT ratio on the LV-side is  $262.44(5/\sqrt{3}) = 757.6$

# Chapter 11

## Transient Stability

11.1 (a)  $\omega_{syn} = 2\pi 60 = \underline{\underline{377}} \text{ rad/s}$

$$\omega_{msyn} = \frac{2}{p} \omega_{syn} = \frac{2}{4} (377) = \underline{\underline{188.5}} \text{ rad/s}$$

(b)  $KE = HS_{rated} = 6 (500 \times 10^6) = \underline{\underline{3.0 \times 10^9}}$  joules

(c) Using (11.1.16)  $\frac{2H}{\omega_{syn}} \omega_{pu}(t) \propto (t) = Pa_{p.u.}(t)$

$$\alpha = \frac{Pa_{p.u.} \omega_{syn}}{2H \omega_{pu}} = \frac{500}{500} \frac{2\pi 60}{(2)(6)(1)} = 31.416 \text{ rad/s}^2$$

$$\alpha_m = \frac{2}{P} \alpha = \frac{2}{4} (31.416) = \underline{\underline{15.708}} \text{ rad/s}^2$$

11.2 Using (11.1.17)

$$J = \frac{2H S_{rated}}{\omega_{msyn}^2} = \frac{(2)(6)(500 \times 10^6)}{(188.5)^2} = \underline{\underline{1.6886 \times 10^5}} \text{ kgm}^2$$

11.3 (a) The kinetic energy in ft-lb is:

$$KE = \frac{1}{2} \left( \frac{WR^2}{32.2} \right) \omega_m^2 \text{ ft-lb}$$

(b) Using  $\omega_m = \left( \frac{2\pi}{60} \right) (\text{rpm})$

$$KE = \frac{1}{2} \left( \frac{WR^2}{32.2} \right) \left[ \frac{2\pi}{60} (\text{rpm}) \right]^2 \text{ ft-lb} \times \frac{1.356 \text{ joules}}{\text{ft-lb}}$$

$$KE = 2.31 \times 10^{-4} (WR^2) (\text{rpm})^2 \text{ joules}$$

Then from (11.1.7):

$$H = \frac{(2.31 \times 10^{-4})(WR^2)(\text{rpm})^2}{S_{\text{rated}}} \text{ per unit-seconds}$$

$$H = \frac{(2.31 \times 10^{-4})(4 \times 10^6)(3600)^2}{800 \times 10^6} = \underline{\underline{14.97}} \text{ per unit-seconds}$$

#### 11.4 Per unit swing equations

$$2H \frac{\omega_{pu}(t)}{\omega_{syn}} \frac{d^2 \delta(t)}{dt^2} = P_{mpu}(t) - P_{epu}(t) = P_{apu}(t)$$

$$\text{Assuming } \omega_{pu}(t) \approx 1 \rightarrow \frac{2H}{\omega_{syn}} \frac{d^2 \delta(t)}{dt^2} = P_{apu}(t)$$

$$\frac{2(5)}{2\pi 60} \frac{d^2 \delta(t)}{dt^2} = 0.7 - (0.40)(0.70) = 0.42 \quad (\text{i.e. a 60\% reduction to 0.4})$$

$$\text{Initial Conditions: } \delta(0) = 12^\circ = 0.2094 \text{ rad; } \frac{d\delta(0)}{dt} = 0$$

Integrating twice and using the above initial conditions:

$$\frac{d\delta(t)}{dt} = 15.83 t + 0$$

$$\delta(t) = 7.915 t^2 + 0.2094$$

At  $t = 5$  cycles = 0.08333 seconds

$$\delta(5 \text{ cycles}) = 7.915 (0.08333)^2 + 0.2094$$

$$\delta(5 \text{ cycles}) = 0.2644 \text{ rad} = 15.15^\circ$$

$$11.5 \quad H = \frac{\frac{1}{2} J \omega_{m_{syn}}^2}{S_{\text{rated}}}; \quad \omega_{m_{syn}} = \frac{2}{p} (2\pi f)$$

$$\text{so } H_{50} = H_{60} \frac{50^2}{60^2} = H_{60} \left( \frac{5}{6} \right)^2$$

$$11.6 \quad (\text{a}) \quad \omega_{syn} = 2 \cdot \pi \cdot 60 = 377 \text{ rad/s}$$

$$\omega_{m_{syn}} = \frac{2}{p} \omega_{syn} = \left( \frac{2}{16} \right) 377 = 47.125 \text{ rad/s}$$

$$(\text{b}) \quad H = 1.5 \text{ p.u.-s}$$

$$\frac{3}{2\pi 60} \omega_{p.u.}(t) \frac{d^2 \delta(t)}{dt^2} = p_{mpu}(t) - p_{epu}(t)$$

$$(c) \quad \delta(0) = 10^\circ = 0.1745 \text{ rad}; \quad \frac{d\delta(0)}{dt} = 0$$

$$\frac{3}{(2\pi 60)} \frac{d^2\delta(t)}{dt^2} = 0.5 \text{ for } t \geq 0$$

$$\frac{d\delta(t)}{dt} = \left(\frac{2\pi 60}{6}\right)t + 0$$

$$\delta(t) = \left(\frac{2\pi 60}{12}\right)t^2 + 0.1745$$

At  $t = 3$  cycles = 0.05 seconds

$$\begin{aligned} \delta(0.05) &= \left(\frac{2\pi 60}{12}\right)(0.05)^2 + 0.1745 \\ &= 0.0960 \text{ rad} = 5.5^\circ \end{aligned}$$

$$11.7 \quad KE_{gen} = H S_{rated} = (3)(100 \times 10^6) = 3 \times 10^8 \text{ joules}$$

$$\text{For a moving mass } W_{kinetic} = \frac{1}{2} MV^2$$

To equal the energy stored in the generator

$$KE_{gen} = W_{kinetic}$$

$$V = \sqrt{\frac{2(KE_{gen})}{M}}$$

$$V = \sqrt{\frac{2(3 \times 10^8 \text{ joules})}{80,000 \text{ kg}}} = 86.60 \frac{\text{m}}{\text{s}} = 193.72 \frac{\text{miles}}{\text{hour}}$$

11.8

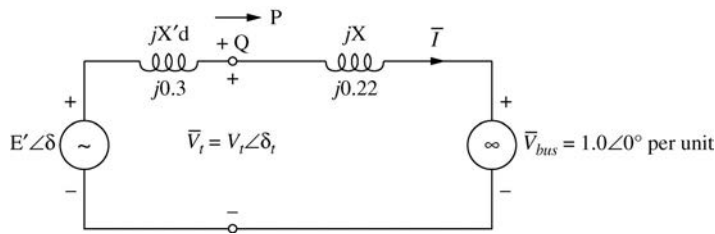

$$(a) \quad P = \frac{V_t V_{bus}}{X} \sin \delta t \quad \Rightarrow \quad \sin \delta t = \frac{(P)(X)}{(V_t)(V_{bus})} = \frac{(0.8)(0.22)}{(1.05)(1.0)} = 0.167619$$

$$\delta t = \sin^{-1}(0.167619) = 9.65^\circ$$

$$\bar{I} = \frac{\bar{V}_t - \bar{V}_{bus}}{jX} = \frac{1.05 \angle 9.65^\circ - 1.0 \angle 0^\circ}{j0.22}$$

$$\bar{I} = \frac{0.03514 + j0.1760}{j0.22} = 0.81579 \angle -11.291^\circ$$

$$\bar{S} = \bar{V}_t \bar{I}^* = (1.05 \angle 9.65^\circ)(0.81579 \angle 11.291^\circ) = 0.85658 \angle 20.941^\circ$$

$$\bar{S} = 0.80 + j0.306 \quad Q = \text{Im} \bar{S} = \underline{0.306} \text{ per unit}$$



$$(b) \bar{E}' = \bar{V}_{bus} + j(X'_d + X)\bar{I} = 1.0\angle 0^\circ + j(0.3 + 0.22)(0.81579\angle -11.291^\circ)$$

$$\bar{E}' = 1.0\angle 0^\circ + 0.4242\angle 78.709^\circ$$

$$\bar{E}' = 1.160\angle 21.01^\circ \text{ per unit}$$

$$(c) P = \frac{E' V_{bus}}{(X'_d + X)} \sin \delta = \frac{(1.160)(1.0)}{0.3 + 0.22} \sin \delta$$

$$P = 2.231 \sin \delta \text{ per unit}$$

**11.9** Circuit during the fault at bus 3:

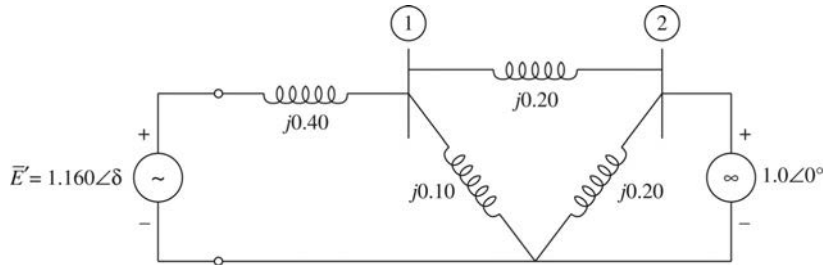

where  $\bar{E}' = 1.160\angle \delta$  is determined in Problem 11.8.

The Thevenin equivalent, as viewed from the generator internal voltage source, shown here, is the same as in Figure 11.9

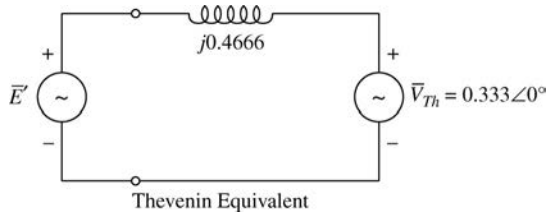

$$P = \frac{\bar{E}' V_{Th}}{x_{Th}} \sin \delta = \frac{(1.160)(0.333)}{0.4666} \sin \delta = \underline{\underline{0.8279}} \sin \delta \text{ per unit}$$

**11.10**

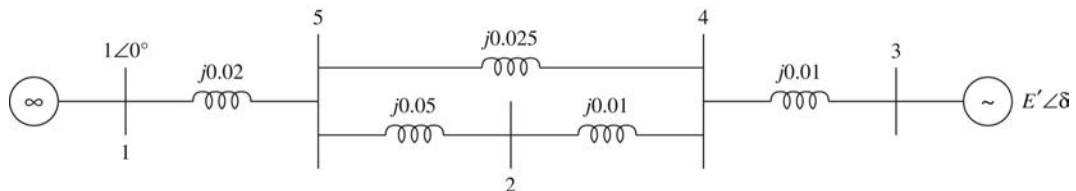

$$\begin{aligned} X_{Th} &= X_{34} + [X_{45} \parallel (X_{42} + X_{25})] + X_{15} \\ &= 0.01 + [0.025 \parallel (0.01 + 0.05)] + 0.02 \\ &= 0.0514 \Omega \end{aligned}$$

11.11

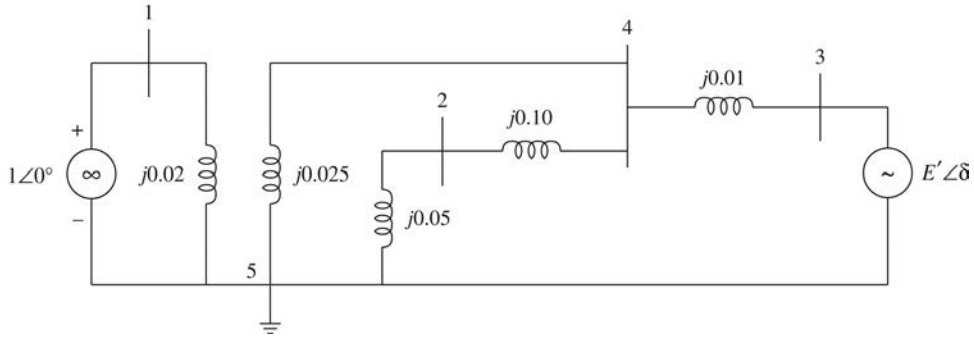

$$\begin{aligned}
 X_{Th} &= X_{34} + [X_{45} \parallel (X_{42} + X_{25})] \\
 &= 0.01 + [0.025 \parallel (0.05 + 0.10)] \\
 &= 0.03143 \Omega
 \end{aligned}$$

11.12

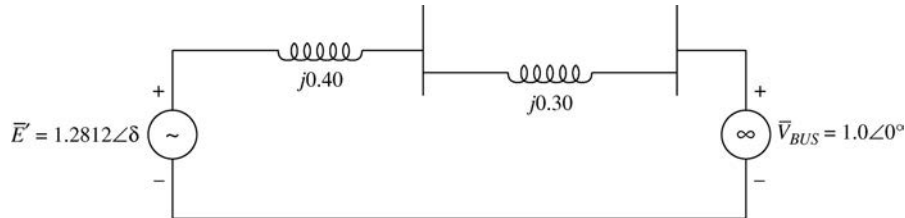

$$P = \frac{E' V_{BUS}}{X_{eq}} \sin \delta = \frac{(1.2812)(1.0)}{0.70} \sin \delta = 1.8303 \sin \delta$$

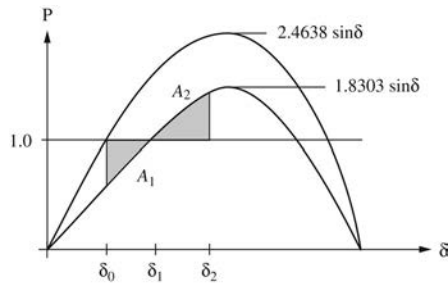

$$\delta_0 = \sin^{-1} \left( \frac{1}{2.4638} \right) = 0.4179 \text{ rad}$$

$$\delta_1 = \sin^{-1} \left( \frac{1}{1.8303} \right) = 0.5780 \text{ rad}$$

$$\begin{aligned}
 A_1 &= \int_{\delta_0=0.4179}^{\delta_1=0.5780} (1.0 - 1.8303 \sin \delta) d\delta = \int_{\delta_1=0.5780}^{\delta_2} (1.8303 \sin \delta - 1) d\delta = A_2 \\
 (0.5780 - 0.4179) + 1.8303(\cos 0.5780 - \cos 0.4179) &= 1.8303(\cos 0.5780 - \cos \delta_2) \\
 &\quad - (\delta_2 - 0.5780)
 \end{aligned}$$

$$1.8303 \cos \delta_2 + \delta_2 = 2.0907$$

$$\text{Solving iteratively (Newton-Raphson)} \quad \delta_2 = \underline{\underline{0.7439 \text{ rad}}} = \underline{\underline{42.62^\circ}}$$

**11.13**

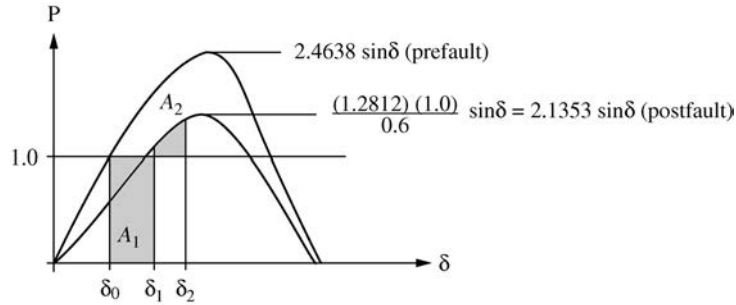

$$\delta_0 = 0.4179 \text{ rad}$$

$$\delta_1 = 0.4964 \text{ rad (From Example 11.4)}$$

$$A_1 = \int_{\delta_0=0.4179}^{\delta_1=0.4964} 1.0 d\delta = \int_{\delta_1=0.4964}^{\delta_2} (2.1353 \sin \delta - 1.0) d\delta$$

$$(0.4964 - 0.4179) = 2.1353 (\cos 0.4964 - \cos \delta_2) - (\delta_2 - 0.4964)$$

$$2.1353 \cos \delta_2 + \delta_2 = 2.2955$$

Solving iteratively using Newton Raphson with  $\delta_2(0) = 0.60 \text{ rad}$

$$\delta_2(i+1) = \delta_2(i) + [-2.1353 \sin \delta_2(i) + 1]^{-1} [2.2955 - 2.1353 \cos \delta_2(i) - \delta_2(i)]$$

i	0	1	2	3	4
$\delta_2$	0.60	0.925	0.804	0.785	0.7850

$$\delta_2 = 0.7850 \text{ rad} = 44.98^\circ$$

**11.14** Referring to Figure 11.8, the critical clearing time occurs when the accelerating area,  $A_1$ , is equal to the decelerating area,  $A_2$ , in which the maximum value of  $d$  is determined from the post-fault curve.

$$1 - 2.1353 \sin \delta_{\max} = 0 \rightarrow \delta_{\max} = 2.654 \text{ rad} = 152.1^\circ$$

To determine the clearing time, first solve for the critical clearing angle. The post fault curve is the same as in problem 11.13, so we have

$$A_1 = \int_{\delta_0=0.4179}^{\delta_{cr}} 1.0 d\delta = \int_{\delta_{cr}}^{\delta_{\max}=2.654} (2.1353 \sin \delta - 1.0) d\delta$$

$$(\delta_{cr} - 0.4179) = 2.1353 (\cos \delta_{cr} - \cos (2.654)) - (2.654 - \delta_{cr})$$

$$0.3496 = 2.1353 \cos \delta_{cr} \rightarrow \delta_{cr} = 1.4063 \text{ rad} = 80.58^\circ$$

Then we can solve for  $t_{cr}$  as in Example 11.5

$$t_{cr} = \sqrt{\frac{4H}{(2\pi 60)(1.0)}} (1.4063 - 0.4179) = 0.1774 \text{ sec} = 10.6 \text{ cycles}$$

**11.15** If gen 3  $X'_d = 0.24$  on a 800 MVA base, then it is 0.03 on a 100 MVA base.

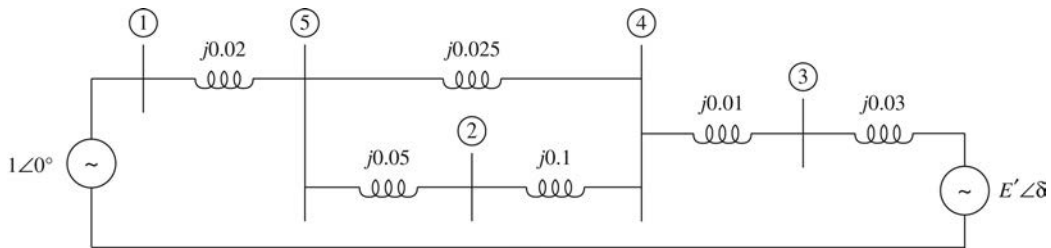

(a)  $X_{eq} = 0.02 + [0.025 \parallel 0.15] + 0.04 = 0.0814$

$$I = \left( \frac{3.00}{1\angle 0} \right)^* = 3\angle 0 \quad E' = 1.0 + j0.0814 \cdot 3\angle 0$$

$$E' = 1 + j0.2442 = 1.0294\angle 13.7^\circ$$

(b) The faulted network is

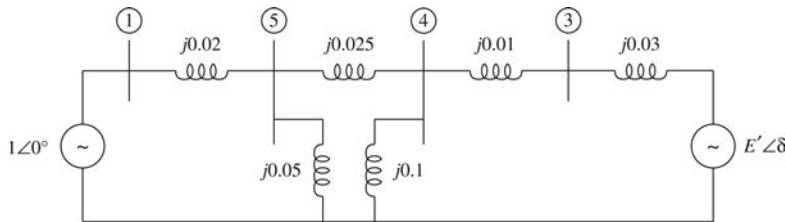

$$X_{eq} = 0.03 + 0.01 + \left\{ 0.1 \parallel [0.025 + (0.02 \parallel 0.05)] \right\}$$

$$= 0.0682$$

$$V_{eq} = 1\angle 0 \cdot \frac{0.0357}{0.0557} \cdot \frac{0.1}{0.125} = 0.5130\angle 0$$

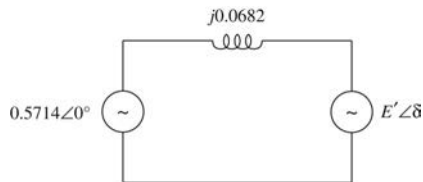

$$P_{e2} = \frac{1.0294 \cdot 0.513}{0.0682} \sin \delta$$

$$= 7.742 \sin \delta$$

Once the fault is cleared, the network becomes

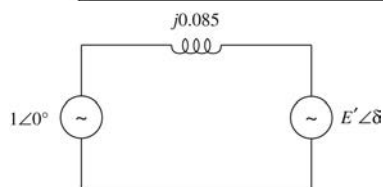
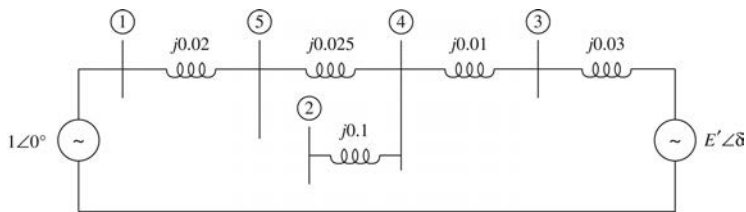

$$P_{e3} = \frac{1.0294 \cdot 1}{0.085} \sin \delta$$

$$= 12.11 \sin \delta$$

**11.16** The system has no critical clearing angle because

$$\int_{\delta^0}^{\pi} P_m - P_{e2} \sin \delta = \text{Accelerating area}$$

$$\delta^0 = 13.7^\circ = 0.239 \text{ rad}$$

$$= 3(\pi - 0.239) - P_{e2} \cos \delta \Big|_{0.239}^{\pi}$$

with  $P_{e2} = 7.742$

$$\rightarrow 3(2.9026) + 7.742 \cdot (-1 - 0.971) = -6.551$$

is less than zero

**11.17**  $\frac{dx}{dt} = -x, \quad x(0) = 10, \quad \Delta t = 0.1$

(a)  $x(t + \Delta t) = x(t) + \frac{dx(t)}{dt} \Delta t$

$$x(0.1) = 10 + (-10)(0.1) = 9$$

$$x(0.2) = 9 + (-9)(0.1) = 8.1$$

$$x(0.3) = 8.1 + (-8.1)(0.1) = 7.29$$

$$x(0.4) = 7.29 + (-7.29)(0.1) = 6.561$$

$$x(0.5) = 6.561 + (-6.561)(0.1) = 5.9049$$

(b)  $\tilde{x}(0) = x(0) + \frac{dx(0)}{dt} \Delta t = 10 + (-10)(0.1) = 9$

$$\frac{d\tilde{x}(0)}{dt} = -9$$

$$x(t + \Delta t) = x(t) + \left( \frac{\frac{dx(t)}{dt} + \frac{d\tilde{x}(t)}{dt}}{2} \right) \Delta t$$

$$x(0.1) = 10 + \frac{(-10 + (-9))}{2} (0.1) = 9.05$$

$t$	0	0.1	0.2	0.3	0.4	0.5
$\tilde{x}$	9	8.145	7.371225	6.670959	6.037218	5.463682
$x$	10	9.05	8.19025	7.412176	6.7080195	6.0707577

**11.18**  $\frac{dx_1}{dt} = x_2 \quad x_1(0) = 1.0 \quad \Delta t = 0.1$

$$\frac{dx_2}{dt} = -x_1 \quad x_2(0) = 0$$

$$\begin{aligned}
\text{(a)} \quad x_1(0.1) &= x_1(0) + \frac{dx_1(0)}{dt} \Delta t = 1.0 + 0(0.1) = 1.0 \\
x_2(0.1) &= x_2(0) + \frac{dx_2(0)}{dt} \Delta t = 0 - 1.0(0.1) = -0.1 \\
x_1(0.2) &= 1 + (-0.1)(0.1) = 0.99 \\
x_2(0.2) &= (-0.1) + (-1)(0.1) = -0.2 \\
x_1(0.3) &= 0.99 + (-0.2)(0.1) = 0.97 \\
x_2(0.3) &= -0.2 + (-0.99)(0.1) = -0.299
\end{aligned}$$

$t$	0	1	2	3
$x_1$	1.0	1.0	0.99	0.97
$x_2$	0	-0.1	-0.2	-0.299

$$\begin{aligned}
\text{(b)} \quad \tilde{x}_1 &= x_1 + \left(\frac{dx_1}{dt}\right) \Delta t & \frac{d\tilde{x}_1}{dt} &= \tilde{x}_2 & x_1(t + \Delta t) &= x_1(t) + \left(\frac{\frac{dx_1(t)}{dt} + \frac{d\tilde{x}_1(t)}{dt}}{2}\right) \Delta t \\
\tilde{x}_2 &= x_2 + \left(\frac{dx_2}{dt}\right) \Delta t & \frac{d\tilde{x}_2}{dt} &= -\tilde{x}_1 & x_2(t + \Delta t) &= x_2(t) + \left(\frac{\frac{dx_2(t)}{dt} + \frac{d\tilde{x}_2(t)}{dt}}{2}\right) \Delta t
\end{aligned}$$

$$\tilde{x}_1(0) = 1.0 + (0)(0.1) = 1.0$$

$$\tilde{x}_2(0) = 0 + (-1.0)(0.1) = -0.1$$

$$\begin{aligned}
x_1(0.1) &= x_1(0) + \left(\frac{\frac{dx_1(0)}{dt} + \frac{d\tilde{x}_1(0)}{dt}}{2}\right) \Delta t \\
&= 1.0 + \left(\frac{0 + (-0.1)}{2}\right)(0.1) = 0.995
\end{aligned}$$

$$x_2(0.1) = 0 + \left(\frac{-1.0 + (-1.0)}{2}\right)(0.1) = -0.1$$

$$\frac{d\tilde{x}_1(0)}{dt} = -0.1$$

$$\frac{d\tilde{x}_2(0)}{dt} = -1.0$$

$t$	0	0.1	0.2	0.3
$\tilde{x}_1$	1	0.994	0.978428	0.956936
$\tilde{x}_2$	-0.1	-0.1995	-0.25773	-0.31753
$x_1$	1	0.995	0.980025	0.95915
$x_2$	0	-0.1	-0.159725	-0.22161

11.19

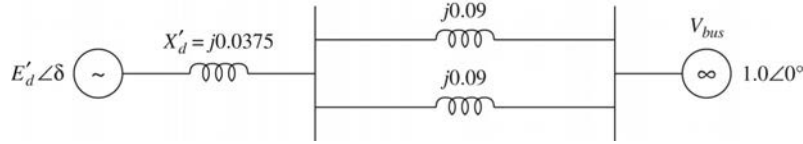

$H = 20 \text{ sec p.u.}$

$D = 0.1 \text{ p.u}$

100 MVA base

(a)  $X_{eq} = 0.0375 + (0.09 \parallel 0.09) = 0.0825$

$$I = \frac{P}{V_{bus}(pf)} \angle -\cos^{-1}(pf) = \frac{\left(\frac{400}{100}\right)}{(1.0)(1.0)} \angle 0^\circ = 4.0 \angle 0^\circ$$

$$\begin{aligned} \bar{E}' &= E' \angle \delta = V_{bus} + jX_{eq}I \\ &= 1.0 \angle 0^\circ + j0.0825(4 \angle 0^\circ) \\ &= 1 + j0.33 \\ &= 1.053 \angle 18.2629^\circ \end{aligned}$$

(b)  $\frac{d\delta_t}{dt} = \omega_t - \omega_{syn}$

$$\frac{d\omega_t}{dt} = \frac{P_{apu} \omega_{syn}}{2H\omega_{pu}} = \frac{\omega_{syn} - D \frac{d\delta_t}{dt}}{2H_{ap.u.}}$$

$$P_{apu} 1.0 - 0 - \left(\frac{1}{\omega_{syn}}\right) \left(\frac{d\delta_t}{dt}\right)$$

(c)  $\delta_{t+\Delta t} = \delta_t + \frac{d\delta_t}{dt} \Delta t = \delta_t + \Delta t (\omega_t - \omega_{syn})$

$$\omega_{t+\Delta t} = \omega_t + \frac{d\omega_t}{dt} \Delta t = \omega t + \Delta t \left[ \frac{\omega_{syn} - 0 \frac{d\delta_t}{dt}}{2H\omega_{pu}} \right]$$

$$\Delta t = \frac{1}{60} = 0.01667 \text{ s}$$

$$\omega_0 = \omega_{syn} = 2\pi 60 = 377$$

$$\delta_0 = 18.2629^\circ = 0.3187 \text{ rad from (a).}$$

$$\delta_{0.01667} = 0.3187 + (377 - 377)(0.01667) = 0.3187$$

$$\omega_{0.01667} = 377 + (0.01667) \left[ \frac{377 - 0.1(0)}{2(20)(1)} \right] = 377.015711$$

$$\delta_{0.0333} = 0.3187 + (0.01667)(377.015711 - 377) = \underline{0.334411 \text{ rad} = 19.16^\circ}$$

$$\omega_{0.0333} = 377.015711 + 10.01667 \left[ \frac{377 - 0.1(0.015711)}{2(20)(1)} \right] = 377.1728 \text{ rad}$$

**11.20** The critical clearing time for a solid fault midway between buses 1 and 3 is about 0.18 seconds. Below is a plot of the generator rotor angle with the fault cleared at 0.18 seconds.

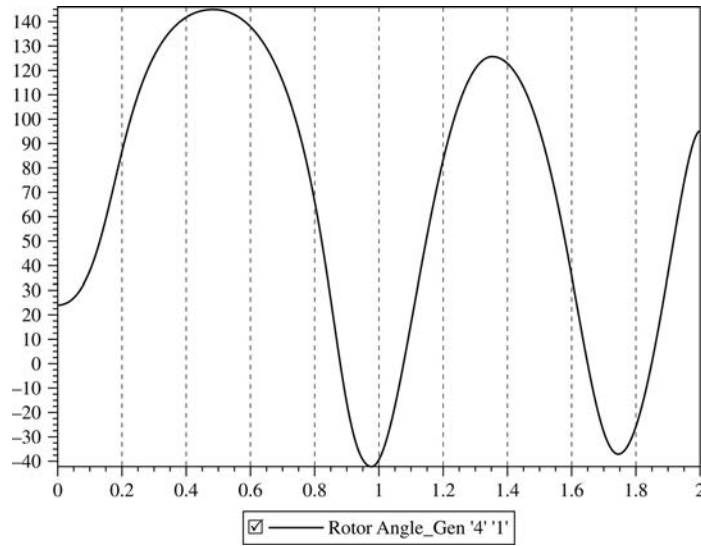

**11.21** The critical clearing time for a solid fault midway between buses 1 and 2 is about 0.164 seconds. Below is a plot of the generator rotor angle with the fault cleared at 0.164 seconds.

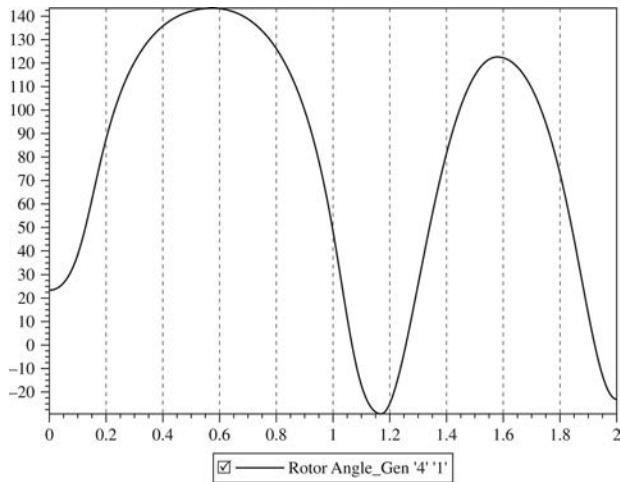

**11.22 (a)** By inspection:

$$Y_{bus} = j \begin{bmatrix} -30 & 20 & 10 & 0 & 0 & 0 \\ 20 & -30 & 0 & 10 & 0 & 0 \\ 10 & 0 & -50 & 0 & 40 & 0 \\ 0 & 10 & 0 & -50 & 40 & 0 \\ 0 & 0 & 40 & 40 & -100 & 20 \\ 0 & 0 & 0 & 0 & 20 & -20 \end{bmatrix}$$



$$(b) Y_{22} = \begin{bmatrix} \frac{1}{jX'_{d1}} & 0 & 0 \\ 0 & \frac{1}{jX'_{d2}} & 0 \\ 0 & 0 & \frac{1}{jX'_{d3}} \end{bmatrix} = \begin{bmatrix} -j5 & 0 & 0 \\ 0 & -j10 & 0 \\ 0 & 0 & -j10 \end{bmatrix} \text{ p.u.}$$

$$Y_{12} = \begin{bmatrix} \frac{-1}{jX'_{d1}} & 0 & 0 \\ 0 & \frac{-1}{jX'_{d2}} & 0 \\ 0 & 0 & 0 \\ 0 & 0 & 0 \\ 0 & 0 & 0 \\ 0 & 0 & \frac{-1}{jX'_{d3}} \end{bmatrix} = \begin{bmatrix} j5.0 & 0 & 0 \\ 0 & j10 & 0 \\ 0 & 0 & 0 \\ 0 & 0 & 0 \\ 0 & 0 & 0 \\ 0 & 0 & j10 \end{bmatrix} \text{ p.u.}$$

$$Y_{\text{load}_3} = \frac{3.0 - j2.0}{1^2} = 3 - j^2$$

$$Y_{\text{load}_4} = \frac{2 - j0.9}{1^2} = 2 - j0.9$$

$$Y_{\text{load}_5} = 1 - j0.3$$

$$Y_{11} = \begin{bmatrix} -j35 & j20 & j10 & 0 & 0 & 0 \\ j20 & -j40 & 0 & j10 & 0 & 0 \\ j10 & 0 & (3 - j2) & 0 & j40 & 0 \\ 0 & j10 & 0 & (2 - j50.9) & j40 & 0 \\ 0 & 0 & j40 & j40 & (1 - j100.3) & j20 \\ 0 & 0 & 0 & 0 & j20 & -j30 \end{bmatrix}$$

**11.23 (a)** By inspection with line 3-5 open:

$$Y_{\text{bus}} = j \begin{bmatrix} -30 & 20 & 10 & 0 & 0 & 0 \\ 20 & -30 & 0 & 10 & 0 & 0 \\ 10 & 0 & -10 & 0 & 0 & 0 \\ 0 & 10 & 0 & -50 & 40 & 0 \\ 0 & 0 & 0 & 40 & -60 & 20 \\ 0 & 0 & 0 & 0 & 20 & -20 \end{bmatrix}$$

$$Y_{\text{Load}_3} = \frac{3.0 - j2.0}{(1.0)^2} = 3.0 - j2.0 \text{ p.u.}$$

$$Y_{\text{Load}_4} = \frac{2.0 - j0.9}{(1.0)^2} = 2.0 - j0.9 \text{ p.u.}$$

$$Y_{\text{Load}_5} = \frac{1.0 - j0.3}{(1.0)^2} = 1.0 - j0.3 \text{ p.u.}$$

$$Y_{11} = \begin{bmatrix} -j35 & j20 & j10 & 0 & 0 & 0 \\ 20 & -j40 & 0 & j10 & 0 & 0 \\ j10 & 0 & (3 - j12) & 0 & 0 & 0 \\ 0 & j10 & 0 & (2 - j50.9) & j40 & 0 \\ 0 & 0 & 0 & j40 & (1 - j60.3) & j20 \\ 0 & 0 & 0 & 0 & j20 & -j30 \end{bmatrix}$$

$$Y_{22} = \begin{bmatrix} 1/(jX'_{d1}) & 0 & 0 \\ 0 & 1/(jX'_{d2}) & 0 \\ 0 & 0 & 1/(jX'_{d3}) \end{bmatrix} = \begin{bmatrix} -j5.0 & 0 & 0 \\ 0 & -j10 & 0 \\ 0 & 0 & -j10 \end{bmatrix} \text{ per unit}$$

$$Y_{12} = \begin{bmatrix} j5 & 0 & 0 \\ 0 & j10 & 0 \\ 0 & 0 & 0 \\ 0 & 0 & 0 \\ 0 & 0 & 0 \\ 0 & 0 & j10 \end{bmatrix} \text{ per unit}$$

(b)  $Y_{\text{bus}}$  is same as 11.22.

$$Y_{11} = \begin{bmatrix} -j35 & j20 & j10 & 0 & 0 & 0 \\ j20 & -j30 & 0 & j10 & 0 & 0 \\ j10 & 0 & -j50 & 0 & j40 & 0 \\ 0 & j10 & 0 & (2 - j50.9) & j40 & 0 \\ 0 & 0 & j40 & j40 & (1 - j100.3) & j20 \\ 0 & 0 & 0 & 0 & j20 & -j30 \end{bmatrix} \text{ per unit}$$

$Y_{12}$  and  $Y_{22}$  are the same as Problem 11.22 and 11.23 (a).

**11.24** The critical clearing time is 0.383 seconds using a time step of 0.01 seconds for the simulation.

**11.25** The critical clearing time for a fault on the line between buses 44 and 14 for the Example 11.9 case with the fault occurring near bus 14 is about 0.584 seconds. Below is a plot of the generator angles with this clearing time.

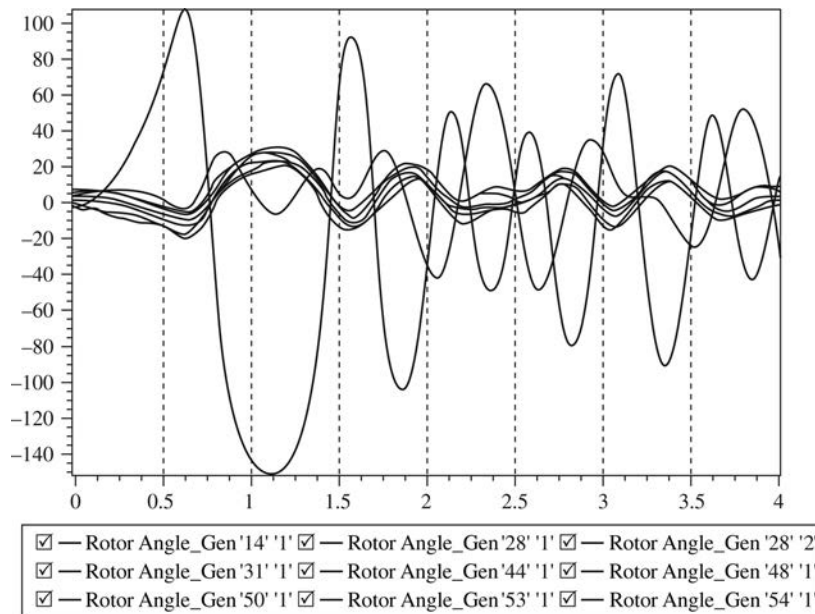

**11.26 (a)**  $I = \frac{1.0}{(1.0)(1.0)} \angle 0^\circ = 1.0 \angle 0^\circ$

$$\begin{aligned} V_T &= 1.0 \angle 0^\circ + j0.22(1 \angle 0^\circ) \\ &= 1 + j0.22 \\ &= 1.0239 \angle 12.4070^\circ \end{aligned}$$

$$\begin{aligned} \bar{E} &= 1.0239 \angle 12.407^\circ + j(2.0)(1 \angle 0^\circ) \\ &= 1 + j2.22 \\ &= 2.4166 \angle 65.556^\circ \quad \delta = 65.556^\circ \end{aligned}$$

$$\begin{bmatrix} V_d \\ V_q \end{bmatrix} = \begin{bmatrix} 0.9104 & -0.4138 \\ 0.4138 & 0.9104 \end{bmatrix} \begin{bmatrix} 1.0 \\ 0.22 \end{bmatrix} = \begin{bmatrix} 0.8194 \\ 0.6109 \end{bmatrix}$$

$$\begin{bmatrix} I_d \\ I_q \end{bmatrix} = \begin{bmatrix} 0.9104 & -0.4138 \\ 0.4138 & 0.9104 \end{bmatrix} \begin{bmatrix} 1.0 \\ 0 \end{bmatrix} = \begin{bmatrix} 0.9104 \\ 0.4138 \end{bmatrix}$$

$$\begin{aligned} E'_q &= V_q + R_a I_q + X_d I_d = 0.61409 + (0)(0.4138) + (0.3)(0.9104) \\ &= 0.88721 \end{aligned}$$

$$\begin{aligned} E'_d &= V_d + R_a I_d - x_a I_a = 0.8194 + 0 - (0.5)(0.4138) \\ &= 0.6125 \end{aligned}$$

$$\begin{aligned}
 E_{fd} &= T_d \left( \frac{dE_q}{dt} \right) + (X_d - X'_d) I_d + E_d \\
 &= 0 + (2.1 - 0.3)(0.9104) + 0.88721 \\
 &= 2.5259
 \end{aligned}$$

(b) The critical clearing time is 0.228 seconds using a time step of 0.01 seconds for the simulation.

**11.27** Using a time step of 0.01 seconds for the simulation, the critical clearing time is 0.340 sec. This is faster than the critical clearing time of Problem 11.24 by 0.043 seconds.

$$\mathbf{11.28} \quad X' = X_a + \frac{X_1 X_m}{X_1 + X_m} = 0.067 + \frac{(0.17)(3.8)}{(0.17 + 3.8)} = 0.2297 \text{ p.u.}$$

$$X = X_a + X_m = 3.867 \text{ p.u.}$$

$$T'_0 = \frac{X_1 + X_m}{\omega_0 R_1} = \frac{(0.17 + 3.8)}{(2\pi 60)(0.0124)} = 0.85 \text{ s}$$

$$I = \frac{1.0}{(1.0)(1.0)} \angle 0^\circ = 1 \angle 0^\circ$$

$$V_t = 1 \angle 0^\circ + (j0.22)(16^\circ) = 1 + j0.22$$

$$\begin{aligned}
 V_r &= E'_r - R_a I_r + X' I_i \\
 &= 0.8475 - (0.013)(0.8433) + (0.2297)(0.7119) = 1.0
 \end{aligned}$$

$$\begin{aligned}
 V_i &= E'_i - R_a I_i - X' I_r \\
 &= 0.4230 - (0.013)(0.7119) + (0.2297)(0.8433) = 0.22
 \end{aligned}$$

$$\frac{dE'_r}{dt} = (2\pi 60)(-0.0129)(0.4230) - \frac{1}{0.85}(0.8475 - (3.867 - 0.2297)(0.7119)) = 0$$

$$\frac{dE'_i}{dt} = -(2\pi 60)(-0.0129)(0.8475) - \frac{1}{0.85}(0.4230 + (3.867 - 0.2297)(0.8433)) = 0$$

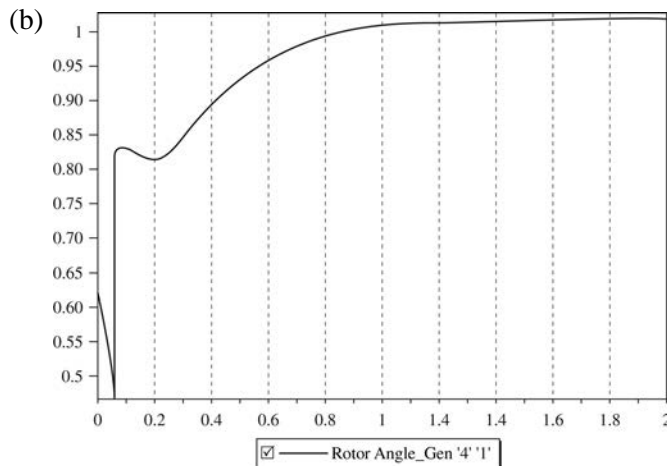

$$11.29 \quad pf = \frac{1}{\sqrt{1^2 + 0.22^2}} = 0.9766$$

$$I = \frac{P}{V_{bus}(pf)} \angle -\cos^{-1}(pf) = \frac{1.0}{(1.0)(0.9766)} \angle -\cos^{-1}(0.9766)$$

$$\begin{aligned} V_T &= 1.0 + (j0.22)(1 - j0.215) \\ &= 1.0473 + j0.22 \\ &= 1.0702 \angle 11.863^\circ \end{aligned}$$

$$\begin{aligned} I_{sore} &= I - \frac{V_T}{jX_{eq}} = (1 - j0.215) + \frac{(1.0473 + j0.22)}{j0.8} \\ &= 1.275 - j1.524 \end{aligned}$$

$$\begin{aligned} I_p + jI_q &= (1.275 - j1.524)(1 \angle -11.863^\circ) \\ &= 1.987 \angle (-50.084 - 11.863) \\ &= 1.987 \angle -61.947^\circ \\ &= 0.934 - j1.754 \end{aligned}$$

$$\begin{aligned} E_q &= -I_q X_{eq} = (1.754)(0.8) \\ &= 1.403 \end{aligned}$$

# Chapter 12

## Power-System Controls

12.1 (a) The open-loop transfer function  $G(S)$  is given by

$$G(S) = \frac{k_a k_e k_f}{(1+T_a S)(1+T_e S)(1+T_f S)}$$

$$(b) \frac{\Delta e}{\Delta V_{ref}} = \frac{1}{1+G(S)} = \frac{(1+T_a S)(1+T_e S)(1+T_f S)}{(1+T_a S)(1+T_e S)(1+T_f S) + k_a k_e k_f}$$

For steady state, setting  $S = 0$

$$\Delta e_{ss} = \frac{(\Delta V_{ref})_{ss}}{1+k}, \text{ where } k = k_a k_e k_f$$

$$\text{or } 1+k = (\Delta V_{ref})_{ss} / \Delta e_{ss}$$

For the condition stipulated,  $1+k \geq 100$

or  $k \geq 99$

$$(c) \Delta V_t(t) = \mathcal{L}^{-1} \left[ \frac{G(S)}{1+G(S)} \Delta V_{ref}(S) \right]$$

The response of the system will depend on the characteristic roots of the equation

$$1+G(S) = 0$$

(i) If the roots  $S_1, S_2,$  and  $S_3$  are real and distinct, the response will then include the transient components  $A_1 e^{S_1 t}, A_2 e^{S_2 t},$  and  $A_3 e^{S_3 t}.$

(ii) If there are a pair of complex conjugate roots  $S_1, S_2 (= a \pm j\omega),$  then the dynamic response will be of the form  $Ae^{at} \sin(\omega t + \phi).$

12.2 (a) The open-loop transfer function of the AVR system is

$$\begin{aligned} KG(S)H(S) &= \frac{K_A}{(1+0.1S)(1+0.4S)(1+S)(1+0.05S)} \\ &= \frac{500K_A}{S^4 + 33.5S^3 + 307.5S^2 + 775S + 500} \end{aligned}$$

The closed-loop transfer function of the system is

$$\frac{V_t(S)}{V_{ref}(S)} = \frac{25K_A(S+20)}{S^4 + 33.5S^3 + 307.5S^2 + 775S + 500 + 500K_A}$$

(b) The characteristic equation is given by

$$1 + KG(S)H(S) = 1 + \frac{500K_A}{S^4 + 33.5S^3 + 307.5S^2 + 775S + 500} = 0$$

Which results in the characteristic Polynomial Equation

$$S^4 + 33.5S^3 + 307.5S^2 + 775S + 500 + 500K_A = 0$$

The Routh-Hurwitz array for this polynomial is shown below:

$S^4$	1	307.5	$500 + 500K_A$
$S^3$	33.5	775	0
$S^2$	284.365	$500 + 500K_A$	0
$S^1$	$58.9K_A - 716.1$	0	0
$S^0$	$500 + 500K_A$		

From the  $S^1$  row, it is seen that  $K_A$  must be less than 12.16 for control system stability; also from the  $S^0$  row,  $K_A$  must be greater than  $-1$ . Thus, with positive values of  $K_A$ , for control system stability, the amplifier gain must be

$$K_A < 12.16.$$

For  $K = 12.16$ , the Auxiliary Equation from the  $S^2$  row is

$$284.365S^2 + 6580 = 0 \quad \text{or} \quad S = \pm j4.81$$

That is, for  $K = 12.16$ , there are a pair of conjugate poles on the  $j\omega$  axis, and the control system is marginally stable.

(c) From the closed-loop transfer function of the system, the steady-state response is

$$(V_t)_{ss} = \lim_{S \rightarrow 0} S V_t(S) = \frac{K_A}{1 + K_A}$$

For the amplifier gain of  $K_A = 10$ , the steady-state response is

$$(V_t)_{ss} = \frac{10}{1 + 10} = 0.909$$

And the steady-state error is

$$(V_e)_{ss} = 1.0 - 0.909 = 0.091$$

**12.3** System becomes unstable at about  $K_a = 277$ . Anything with  $\pm$  about 10 of this answer should be considered correct.

**12.4** The initial values are  $V_t = 1.0946$  pu, and  $E_{fd} = 2.913$ . The final values are with  $K_a = 100$ ,  $V_t = 1.0958$ ,  $E_{fd} = 2.795$ ; with  $K_a = 200$ ,  $V_t = 1.0952$ ,  $E_{fd} = 2.793$ ; with  $K_a = 50$ ,  $V_t = 1.0969$ ,  $E_{fd} = 2.799$ ; with  $K_a = 10$ ,  $V_t = 1.1033$ ,  $E_{fd} = 2.827$ . The steady-state relationship from Figure 12.3 is  $E_{fd} = (K_a/K_e) * (V_{ref} - V_t)$  where  $V_{ref}$  is determined by the pre-fault conditions:

**12.5** (a) Converting the regulation constants to a 100 MVA system base:

$$R_{1_{new}} = 0.03 \left( \frac{100}{200} \right) = 0.015$$

$$R_{2_{new}} = 0.04 \left( \frac{100}{300} \right) = 0.0133$$

$$R_{3_{new}} = 0.06 \left( \frac{100}{500} \right) = 0.012$$

Using (12.2.3):

$$\beta = \left( \frac{1}{0.015} + \frac{1}{0.0133} + \frac{1}{0.012} \right) = \underline{\underline{225.0}} \text{ per unit}$$

(b) Using (12.2.4) with  $\Delta P_{ref} = 0$  and  $\Delta P_m = \frac{-150}{100}$  p.u. = -1.5 p.u.

$$-1.5 = -225.0 \Delta f$$

$$\Delta f = \frac{-1.5}{-225.0} \text{ p.u.} = 6.6666 \times 10^{-3} \text{ per unit} = (6.6666 \times 10^{-3})(60) = \underline{\underline{0.3999}} \text{ Hz}$$

(c) Using (12.2.1) with  $\Delta P_{ref} = 0$ :

$$\Delta P_{m1} = - \left( \frac{1}{0.015} \right) (6.6666 \times 10^{-3}) = -0.4444 \text{ per unit} = \underline{\underline{-44.44}} \text{ MW}$$

$$\Delta P_{m2} = - \left( \frac{1}{0.0133} \right) (6.6666 \times 10^{-3}) = -0.5012 \text{ per unit} = \underline{\underline{-50.12}} \text{ MW}$$

$$\Delta P_{m3} = - \left( \frac{1}{0.012} \right) (6.6666 \times 10^{-3}) = -0.5555 \text{ per unit} = \underline{\underline{-55.55}} \text{ MW}$$

**12.6** (a) Using (12.2.4) with  $\Delta P_{ref} = 0$  and  $\Delta P_m = \frac{100}{100}$  p.u.:

$$1.0 = -225.0 \Delta f$$

$$\Delta f = -4.4444 \times 10^{-3} \text{ per unit} = - (4.4444 \times 10^{-3})(60) = \underline{\underline{-0.2667}} \text{ Hz}$$



(b) Using (12.2.1) with  $\Delta P_{ref} = 0$  :

$$\Delta P_{m1} = -\left(\frac{1}{0.015}\right)(-4.4444 \times 10^{-3}) = 0.2963 \text{ per unit} = \underline{\underline{29.63 \text{ MW}}}$$

$$\Delta P_{m2} = -\left(\frac{1}{0.0133}\right)(-4.4444 \times 10^{-3}) = 0.3333 \text{ per unit} = \underline{\underline{33.33 \text{ MW}}}$$

$$\Delta P_{m3} = -\left(\frac{1}{0.012}\right)(-4.4444 \times 10^{-3}) = 0.3704 \text{ per unit} = \underline{\underline{37.04 \text{ MW}}}$$

**12.7** Using (12.2.1) with  $\Delta P_{ref} = 0$ :  $\Delta f = 0.005$  p.u.

$$\Delta P_{m1} = -\left(\frac{1}{0.015}\right)(0.005) = -0.3333 \text{ per unit} = \underline{\underline{-33.33 \text{ MW}}}$$

$$\Delta P_{m2} = -\left(\frac{1}{0.0133}\right)(0.005) = -0.3759 \text{ per unit} = \underline{\underline{-37.59 \text{ MW}}}$$

$$\Delta P_{m3} = -\left(\frac{1}{0.012}\right)(0.005) = -0.4166 \text{ per unit} = \underline{\underline{-41.66 \text{ MW}}}$$

**12.8** Using (12.2.1) with  $\Delta P_{ref} = 0$ :  $\Delta f = -0.005$  p.u.

$$\Delta P_{m1} = -\left(\frac{1}{0.015}\right)(-0.005) = 0.3333 \text{ per unit} = \underline{\underline{33.33 \text{ MW}}}$$

$$\Delta P_{m2} = -\left(\frac{1}{0.0133}\right)(-0.005) = 0.3750 \text{ per unit} = \underline{\underline{37.50 \text{ MW}}}$$

$$\Delta P_{m3} = -\left(\frac{1}{0.012}\right)(-0.005) = 0.4167 \text{ per unit} = \underline{\underline{41.67 \text{ MW}}}$$

**12.9** (a) Using  $R_{new} = R_{old} \frac{S_{base(new)}}{S_{base(old)}}$

$$R_{1(new)} = 0.04 \frac{1000}{500} = 0.08 \text{ pu}; \quad R_{2(new)} = 0.05 \frac{1000}{750} = 0.067 \text{ pu}$$

The area frequency-response characteristic is given by

$$\beta = \sum_{k=1}^n \frac{1}{R_k} = \frac{1}{R_1} + \frac{1}{R_2} = \frac{1}{0.08} + \frac{1}{0.067} = 27.5 \text{ pu}$$

(b) The per-unit increase in load is  $250/1000 = 0.25$

$$(\Delta P_m)_{TOTAL} = \sum_{k=1}^n \Delta P_{mk} = \sum_{k=1}^n \Delta P_{ref k} - \left(\sum_{k=1}^n \frac{1}{R_k}\right) \Delta f = \Delta P_{ref(total)} - \beta \Delta f$$

With  $\Delta P_{ref(total)} = 0$  for steady-state conditions,

$$\Delta f = -\frac{1}{\beta} \Delta P_m = -\frac{1}{27.5} (0.25) = -9.091 \times 10^{-3} \text{ pu}$$

$$\text{or } \Delta f = -9.091 \times 10^{-3} \times 60 = -0.545 \text{ Hz.}$$

**12.10** Convert the R's to a common MVA base (say 100 MVA).  $R_1 = 100/500 * 0.04 = 0.008$ ,  $R_2 = 100/1000 * 0.05 = 0.005$ ,  $R_3 = 100/750 * 0.05 = 0.00667$ . Then the total  $\beta = 1/R_1 + 1/R_2 + 1/R_3 = 474.9$  per unit. The per unit change in frequency is then  $(-250/100)/474.9 = -0.00526$  per unit =  $-0.316$  Hz. Then changes in the generator outputs are  $P_{g1} = 0.00526/0.008 * 100 = 66$  MW,  $P_{g2} = 0.00526/0.005 * 100 = 105$  MW, while  $P_{g3} = 0.00526/0.00667 * 100 = 79$  MW.

**12.11** Since all the R's are the same, the total  $\beta$  is just the sum of the on-line generators' MVA values (neglecting the contingency bus 50 unit) divided by  $100 \text{ MVA} * 0.05$  which gives  $1035/(100 * 0.05) = 207$  per unit. The expected change in frequency for the loss of 42.1 MW is  $(-42.1/100)/207 = -0.00203$  per unit or  $-0.1218$  Hz, which closely matches the actual (simulated) final frequency deviation of  $-0.124$  Hz. The reason the simulated is larger because of a 0.5 MW increase in the system losses. With this loss changed included (i.e., a loss of 42.6 MW) the analytic value becomes  $-0.123$  Hz. The plot of the bus frequency is given below, with the lowest frequency occurring at about 59.652 Hz at about 3.2 seconds.

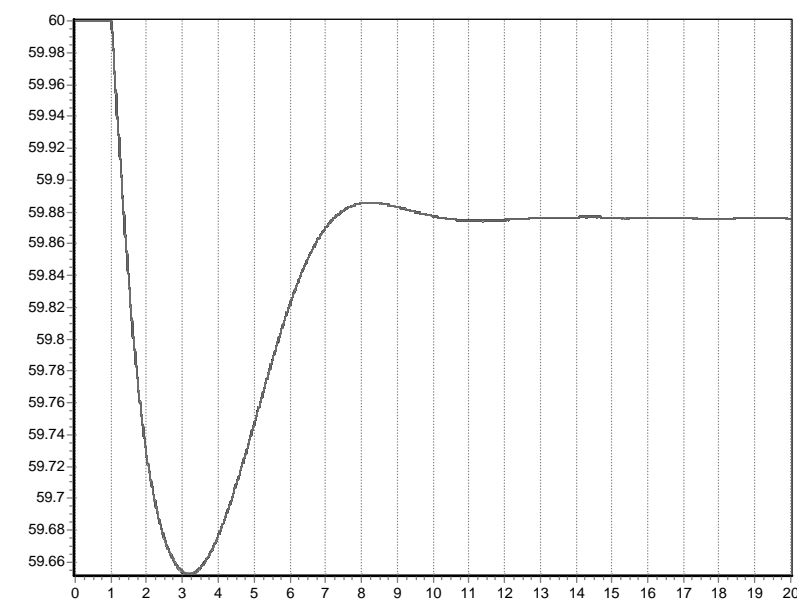

**12.12** Changing the H values has no impact on the final frequency. The impact is the higher system inertia causes a slower decline in system frequency. The plot of the bus frequency is given below, with the lowest frequency now occurring at about 59.714 Hz at about 4.6 seconds.

**12.13** Using a 60 Hz base, the per unit frequency change is  $-0.12/60 = -0.002$  p.u. Since all the governor R values are identical (on their own base), the total MVA of the generation is given by  $\Delta P * R/\Delta f = (2800 * 0.05)/0.02 = 70,000$  MW.

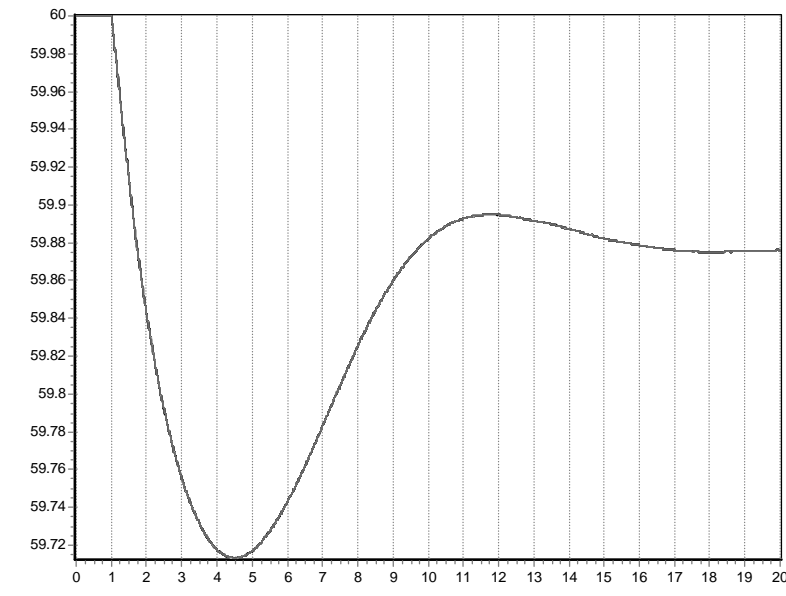

**12.14** Adding (12.2.4) for each area with  $\Delta P_{ref} = 0$  :

$$\Delta P_{m1} + \Delta P_{m2} = -(\beta_1 + \beta_2) \Delta f$$

$$400 = -(600 + 800) \Delta f \Rightarrow \Delta f = \frac{-400}{1400} = \underline{\underline{-0.2857 \text{ Hz}}}$$

$$\Delta P_{tie2} = \Delta P_{m2} = -\beta_2 \Delta f = -800(-0.2857) = \underline{\underline{228.57 \text{ MW}}}$$

$$\Delta P_{tie1} = -\Delta P_{tie2} = \underline{\underline{-228.57 \text{ MW}}}$$

**12.15** In steady-state,

$$ACE_2 = \Delta P_{tie2} + B_{f2} \Delta f = 0 \quad \text{and} \quad \Delta P_{tie2} = \Delta P_{m2}$$

$$\therefore \Delta P_{m2} = \Delta P_{tie2} = -B_{f2} \Delta f$$

$$\text{and } \Delta P_{m1} = -\beta_1 \Delta f$$

$$\text{Also } \Delta P_{m1} + \Delta P_{m2} = 400 \text{ MW}$$

Solving the equations:

$$-(\beta_1 + B_{f2}) \Delta f = 400$$

$$\Delta f = \frac{-400}{600 + 800} = \underline{\underline{-0.2857 \text{ Hz}}}$$

$$\Delta P_{tie2} = -(800)(-0.2857) = \underline{\underline{228.57 \text{ MW}}}$$

$$\Delta P_{tie1} = -\Delta P_{tie2} = \underline{\underline{-228.57 \text{ MW}}}$$

Note: The results are the same as those in Problem 12.14. That is, LFC is not effective when employed in only one area.

**12.16** In steady-state:

$$ACE_1 = \Delta P_{tie1} + B_{f1} \Delta f = 0$$

$$ACE_2 = \Delta P_{tie2} + B_{f2} \Delta f = 0$$

$$\text{Adding } (\Delta P_{tie1} + \Delta P_{tie2}) + (B_{f1} + B_{f2}) \Delta f = 0$$

$$\text{Therefore, } \Delta f = 0; \Delta P_{tie1} = 0 \text{ and } \Delta P_{tie2} = 0.$$

That is, in steady-state the frequency error is returned to zero, area 1 picks up its own 400 MW load increase.

**12.17** (a) (12.15) LFC in area 2 alone.

In steady-state

$$ACE_2 = \Delta P_{tie2} + B_{f2} \Delta f = 0$$

$$\therefore \Delta P_{m2} = \Delta P_{tie2} = -B_{f2} \Delta f$$

$$\text{and } \Delta P_{m1} = -\beta_1 \Delta f$$

$$\text{Also } \Delta P_{m1} + \Delta P_{m2} = -300$$

$$\text{Solving: } -(\beta_1 + B_{f2}) \Delta f = -300$$

$$\Delta f = \frac{300}{600 + 800} = \underline{\underline{0.2142 \text{ Hz}}}$$

$$\Delta P_{tie1} = -(600)(0.2142) = \underline{\underline{-128.52 \text{ MW}}}$$

$$\Delta P_{tie2} = -\Delta P_{tie1} = \underline{\underline{128.52 \text{ MW}}}$$

(b) (12.16) LFC employed in both areas 1 and 2.

$$ACE_1 = \Delta P_{tie1} + B_{f1} \Delta f = 0$$

$$ACE_2 = \Delta P_{tie2} + B_{f2} \Delta f = 0$$

$$\text{Adding: } (\Delta P_{tie1} + \Delta P_{tie2}) + (B_{f1} + B_{f2}) \Delta f = 0$$

$$\text{Thus } \Delta f = 0 \quad \Delta P_{tie1} = 0 \text{ and } \Delta P_{tie2} = 0$$

**12.18 (a)** The per-unit load change in area 1 is

$$\Delta P_{L1} = \frac{187.5}{1000} = 0.1875$$

The per-unit steady-state frequency deviation is

$$\Delta W_{ss} = \frac{-\Delta P_{L1}}{\left(\frac{1}{R_1} + D_1\right) + \left(\frac{1}{R_2} + D_2\right)} = \frac{-0.1875}{(20 + 0.6) + (16 + 0.9)} = -0.005$$

Thus, the steady-state frequency deviation in Hz is

$$\Delta f = (-0.005)(60) = -0.3 \text{ Hz}$$

and the new frequency is  $f = f_0 + \Delta f = 60 - 0.3 = 59.7 \text{ Hz}$ .

The change in mechanical power in each area is

$$\Delta P_{m1} = -\frac{\Delta W}{R_1} = -\frac{-0.005}{0.05} = 0.1 \text{ pu} = 100 \text{ MW}$$

$$\Delta P_{m2} = -\frac{\Delta W}{R_2} = -\frac{-0.005}{0.0625} = 0.08 \text{ pu} = 80 \text{ MW}$$

Thus area 1 increases the generation by 100 MW and area 2 by 80 MW at the new operating frequency of 59.7 Hz.

The total change in generation is 180 MW, which is 7.5 MW less than the 187.5 MW load change because of the change in the area loads due to frequency drop.

The change in area 1 load is  $\Delta W \cdot D_1 = (-0.005)(0.6) = -0.003 \text{ pu}$  or  $-3.0 \text{ MW}$ , and the change in area 2 load is  $\Delta W \cdot D_2 = (-0.005)(0.9) = -0.0045 \text{ pu}$  or  $-4.5 \text{ MW}$ . Thus, the change in the total area load is  $-7.5 \text{ MW}$ . The tie-line power flow is

$$\begin{aligned} \Delta P_{12} &= \Delta W \left( \frac{1}{R_2} + D_2 \right) = -0.005(16.9) = -0.0845 \text{ pu} \\ &= -84.5 \text{ MW} \end{aligned}$$

That is, 84.5 MW flows from area 2 to area 1. 80 MW comes from the increased generation in area 2, and 4.3 MW comes from the reduction in area 2 load due to frequency drop.

- (b) With the inclusion of the  $ACE_5$ , the frequency deviation returns to zero (with a settling time of about 20 seconds). Also, the tie-line power change reduces to zero, and the increase in area 1 load is met by the increase in generation  $\Delta P_{m1}$ .

$$12.19 \quad \frac{dC_1}{dP_1} = 15 + 0.1P_1 = \lambda$$

$$\frac{dC_2}{dP_2} = 20 + 0.08P_2 = \lambda$$

$$P_1 + P_2 = 1000$$

$$\begin{bmatrix} 0.1 & 0 & -1 \\ 0 & 0.08 & -1 \\ 1 & 1 & 0 \end{bmatrix} \begin{bmatrix} P_1 \\ P_2 \\ \lambda \end{bmatrix} = \begin{bmatrix} -15 \\ -20 \\ 1000 \end{bmatrix}$$

$$P_1 = 472.2 \text{ MW}, P_2 = 527.8 \text{ MW}, \lambda = 62.2 \text{ \$/MWh}$$

$$\text{Total cost} = \$41,230/\text{hr}$$

**12.20** Since the unlimited solution violates the  $P_2$  limit constraint,  $P_2 = 500 \text{ MW}$ , which means  $P_1 = 500 \text{ MW}$ . The system lambda is determined by the unlimited unit  $= 15 + 0.1 * 500 = \$65/\text{MWh}$ . Total cost is  $\$41,300/\text{hr}$ .

$$12.21 \quad \frac{dC_1}{dP_1} = 15 + 0.1 P_1 = \lambda$$

$$\frac{dC_2}{dP_2} = 0.95(20 + 0.08P_2) = \lambda$$

$$P_1 + P_2 = 1000$$

$$\begin{bmatrix} 0.1 & 0 & -1 \\ 0 & 0.076 & -1 \\ 1 & 1 & 0 \end{bmatrix} \begin{bmatrix} P_1 \\ P_2 \\ \lambda \end{bmatrix} = \begin{bmatrix} -15 \\ -19 \\ 1000 \end{bmatrix}$$

$$P_1 = 454.5 \text{ MW}, P_2 = 545.5 \text{ MW}, \lambda = 60.5 \text{ \$/MWh}$$

$$\text{Total cost} = \$41,259/\text{hr}$$

$$12.22 \quad \frac{dC_1}{dP_1} \left( \frac{1}{1 - \frac{\partial P_L}{\partial P_1}} \right) = \frac{15 + 0.1P_1}{1 - (4 \times 10^{-4} P_1 - 4 \times 10^{-4} P_2)} = 60.0$$

$$\frac{dC_2}{dP_2} \left( \frac{1}{1 - \frac{\partial P_L}{\partial P_2}} \right) = \frac{20 + 0.08P_2}{1 - (6 \times 10^{-4} P_2 - 4 \times 10^{-4} P_1)} = 60.0$$

Rearranging the above two equations gives

$$(0.1 + 0.024)P_1 - (0.024)P_2 = 45$$

$$(0.08 + 0.036)P_2 - (0.024)P_1 = 40$$

Solving gives  $P_1 = 447.6$ ,  $P_2 = 437.4$ ,  $P_{\text{losses}} = 19.15$  MW,  $P_{\text{load}} = 865.85$  MW,

Total cost = \$34,431/hr

**12.23** For  $N = 2$ , (12.4.14) becomes:

$$\begin{aligned} P_L &= \sum_{i=1}^2 \sum_{j=1}^2 P_i B_{ij} P_j = \sum_{i=1}^2 P_i (B_{i1} P_1 + B_{i2} P_2) \\ &= B_{11} P_1^2 + B_{12} P_1 P_2 + B_{21} P_1 P_2 + B_{22} P_2^2 \end{aligned}$$

Assuming  $B_{12} = B_{21}$ ,

$$\begin{aligned} P_L &= B_{11} P_1^2 + 2B_{12} P_1 P_2 + B_{22} P_2^2 \\ \frac{\partial P_L}{\partial P_1} &= 2(B_{11} P_1 + B_{12} P_2) & \frac{\partial P_L}{\partial P_2} &= 2(B_{12} P_1 + B_{22} P_2) \end{aligned}$$

Also, from (12.4.15):

$$\begin{aligned} i=1 \quad \frac{\partial P_L}{\partial P_1} &= 2 \sum_{j=1}^2 B_{1j} P_j = 2(B_{11} P_1 + B_{12} P_2) \\ i=2 \quad \frac{\partial P_L}{\partial P_2} &= 2 \sum_{j=1}^2 B_{2j} P_j = 2(B_{21} P_1 + B_{22} P_2) \\ &= 2(B_{12} P_1 + B_{22} P_2) \end{aligned}$$

which checks.

**12.24** Choosing  $S_{\text{base}}$  as 100 MVA (3-Phase),

$$\begin{aligned} \alpha_1 &= (S_{3\phi \text{ base}})^2 0.01 = 100; & \alpha_2 &= 40 \\ \beta_1 &= (S_{3\phi \text{ base}}) 2.00 = 200; & \beta_2 &= 260 \\ \gamma_1 &= 100 & ; & \gamma_2 = 80 \end{aligned}$$

In per unit,  $0.25 \leq P_{G1} \leq 1.5$ ;  $0.3 \leq P_{G2} \leq 2.0$ ;  $0.55 \leq P_L \leq 3.5$

$$\lambda_1 = \frac{\partial \zeta_1}{\partial P_{G1}} = 200 P_{G1} + 200; \quad \lambda_2 = \frac{\partial \zeta_2}{\partial P_{G2}} = 80 P_{G2} + 260$$

Calculate  $\lambda_1$  and  $\lambda_2$  for minimum generation conditions (Point 1, in Figure shown below).

Since  $\lambda_2 > \lambda_1$ , in order to make  $\lambda$ 's equal, load unit 1 first until  $\lambda_1 = 284$  which occurs at

$$P_{G1} = \frac{284 - 200}{200} = 0.42 \quad (\text{Point 2 in Figure})$$

Now, calculate  $\lambda_1$  and  $\lambda_2$  at the maximum generation conditions:

Point 3 in Figure, now that  $\lambda_1 > \lambda_2$ , unload unit 1 first until  $\lambda_1$  is brought down to  $\lambda_1 = 420$  which occurs at

$$P_{G1} = \frac{420 - 200}{200} = 1.10 \text{ (Point 4 in Figure)}$$

Notice that, for  $0.72 \leq P_L \leq 3.1$ , it is possible to maintain equal  $\lambda$ 's. Equations are given by

$$\lambda_1 = \lambda_2; 200P_{G1} + 200 = 80P_{G2} + 260; \text{ and } P_{G1} + P_{G2} = P_L$$

These linear relationships are depicted in the Figure below:

For  $P_L = 282 \text{ MW} = 2.82 \text{ pu}$ ,  $P_{G2} = 2.82 - P_{G1}$ ;

$$P_{G1} = 0.4P_{G2} + 0.3 = 1.128 - 0.4P_{G1} + 0.3$$

$$1.4P_{G1} = 1.428 \text{ or } P_{G1} = 1.02 = 102 \text{ MW}$$

$$P_{G2} = 2.82 - 1.02 = 1.8 = 180 \text{ MW}$$

Results are tabulated in the table given below:

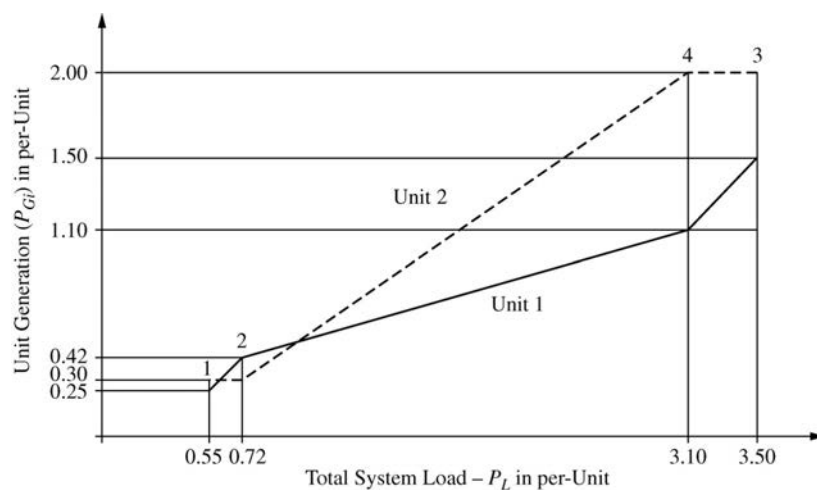
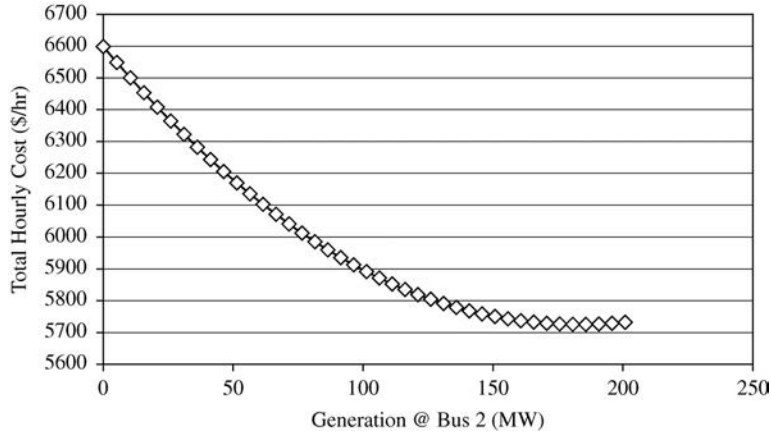

Table of Results

Point	$P_{G1}$	$P_{G2}$	$P_L$	$\lambda_1$	$\lambda_2$
1	0.25	0.30	0.55	250	284
2	0.42	0.30	0.72	284	284
3	1.50	2.00	3.50	500	420
4	1.10	2.00	3.10	420	420



**12.25** (To solve the problem change the Min MW field for generator 2 to 0 MW). The minimum value in the plot above occurs when the generation at bus 2 is equal to 180MW. This value corresponds to the value found in Example 12.8 for economic dispatch at generator 2 (181MW).



**12.26** To achieve loss sensitivity values that are equal the generation at bus 2 should be about 159 MW and the generation at bus 4 should be about 215 MW. Minimum losses are 7.79 MW. The operating cost in Example 12.10 is lower than that found in this problem indicating that minimizing losses does not usually result in a minimum cost dispatch. The minimum loss one-line is given below.

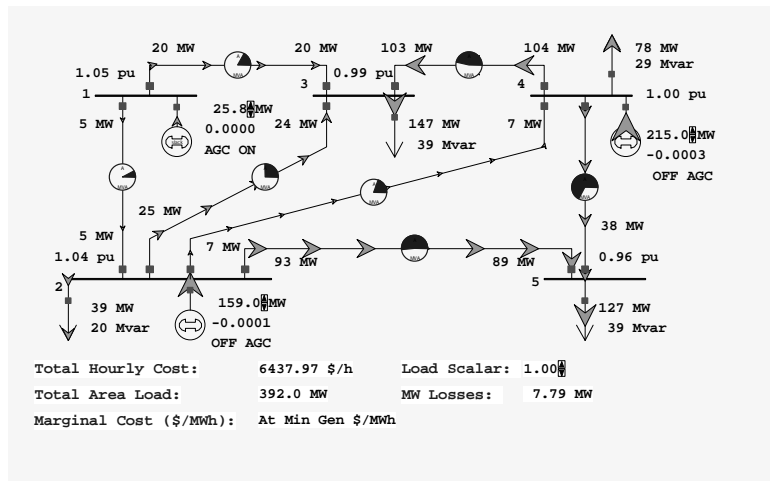

**12.27** To achieve loss sensitivity values that are equal the generation at bus 2 should be about 230 MW and the generation at bus 4 should be at its maximum limit of 300 MW. Minimum losses are 15.38 MW. The minimum loss one-line is given below.

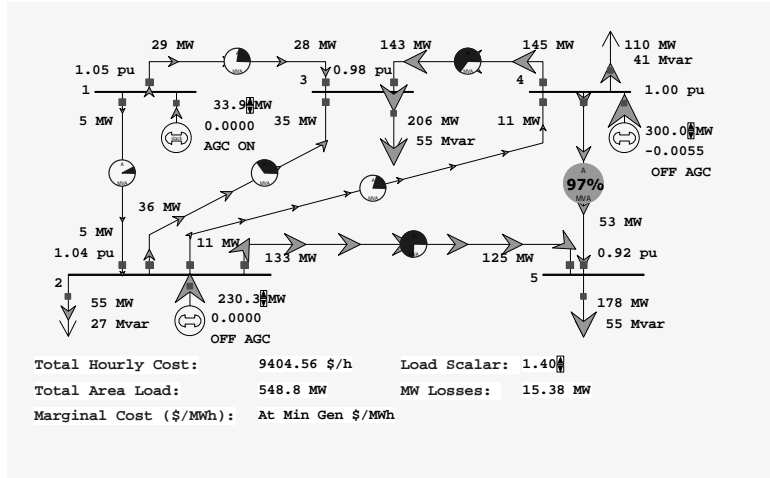

**12.28** The line between buses 2 and 5 reaches 100% at a load scalar of about 1.68; above this value the flow on this line is constrained to 100%, causing the additional load into bus 5 to increase the flow on the line between buses 4 and 5. This line reaches its limit at a load scalar of 1.81. Since both lines into bus 5 are loaded at 100%, no additional load can be brought into the bus without causing at least one of these lines to be overloaded. The plot of the bus 5 MW marginal cost is given below.

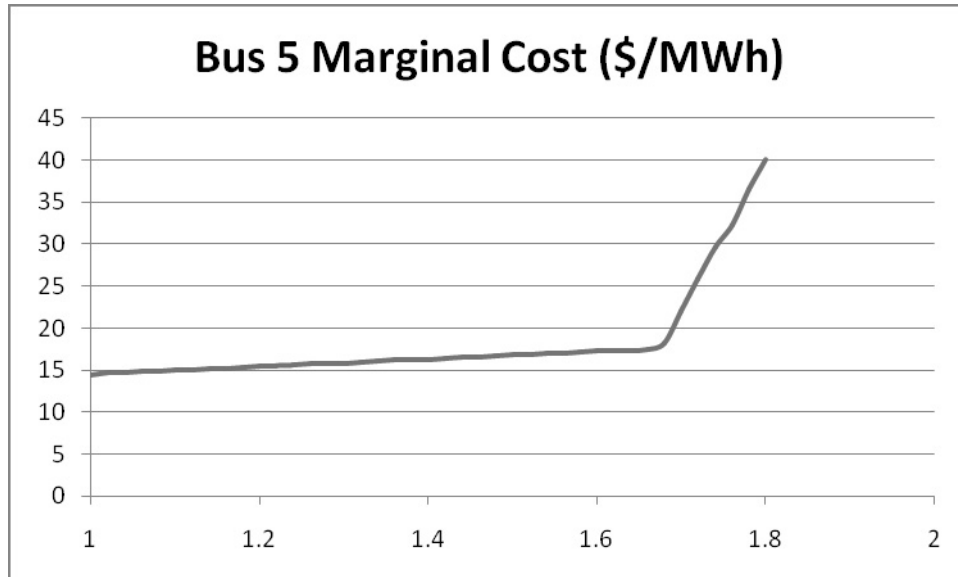

**12.29** The OPF solution for this case is given below, with an operating cost of 16,091.6 \$/hr. The marginal cost at bus UIUC69 is 41.82 \$/hr. Increasing the UIUC69 MW load from 61 to 62 MW increases the operating cost to \$16,132.80, an increase of \$41.2, verifying the marginal cost. Similarly at the DEMAR69 bus the marginal cost is 17.74 \$/hr; increasing the load from 44 to 45 MW increases the operating cost by \$17.8. Note, because of convergence tolerances the manually calculated changes may differ slightly from the marginal cost values.

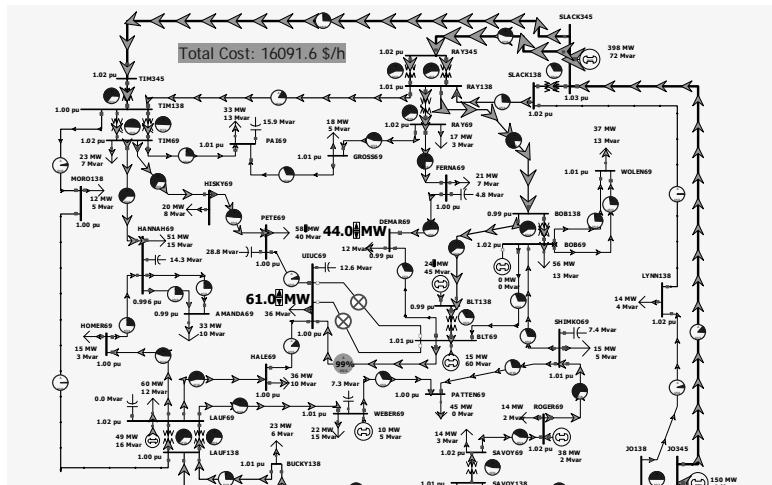

**12.30** The Hannah69 LMP goes above \$40/MWh when the area load multiplier is 1.48. The associated one-line for this operating condition is shown below.

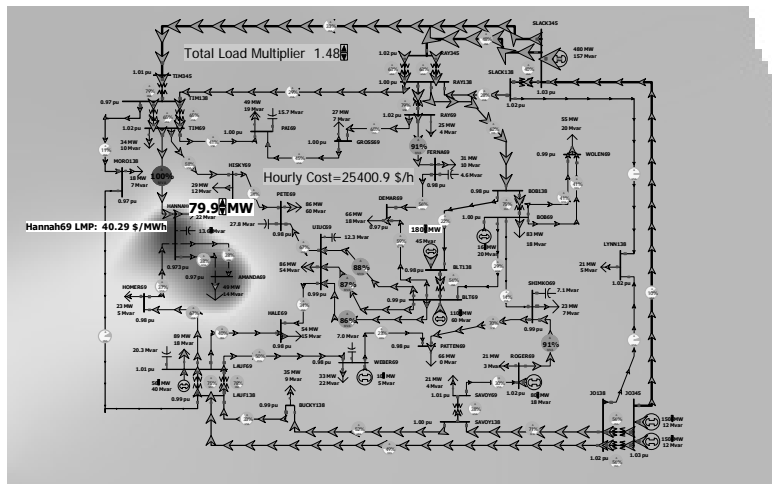

# Chapter 13

## Transmission Lines: Transient Operation

13.1 From the results of Example 13.2:

$$V(x,t) = \frac{E}{2} U_{-1} \left( t - \frac{x}{v} \right) + \frac{E}{2} U_{-1} \left( t + \frac{x}{v} - 2\tau \right)$$

$$i(x,t) = \frac{E}{2Z_c} U_{-1} \left( t - \frac{x}{v} \right) - \frac{E}{2Z_c} U_{-1} \left( t + \frac{x}{v} - 2\tau \right)$$

For  $t = \tau/2 = \frac{l}{2v}$  :

$$V \left( x, \frac{\tau}{2} \right) = \frac{E}{2} U_{-1} \left( \frac{l-x}{v} \right) + \frac{E}{2} U_{-1} \left( \frac{x-\frac{3}{2}l}{v} \right)$$

$$i \left( x, \frac{\tau}{2} \right) = \frac{E}{2Z_c} U_{-1} \left( \frac{l-x}{v} \right) - \frac{E}{2Z_c} U_{-1} \left( \frac{x-\frac{3}{2}l}{v} \right)$$

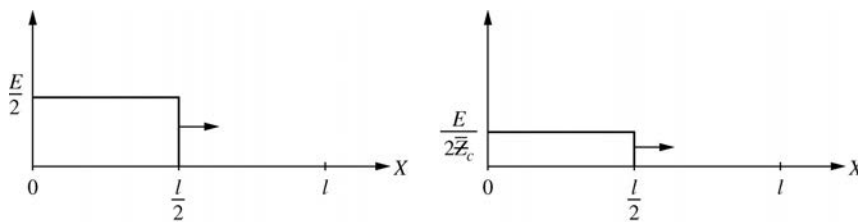

For  $t = \tau = \frac{l}{v}$ :

$$V(x, \tau) = \frac{E}{2} U_{-1} \left( \frac{l-x}{v} \right) + \frac{E}{2} U_{-1} \left( \frac{x-l}{v} \right) \quad i(x, \tau) = \frac{E}{2Z_c} U_{-1} \left( \frac{l-x}{v} \right) - \frac{E}{2Z_c} U_{-1} \left( \frac{x-l}{v} \right)$$

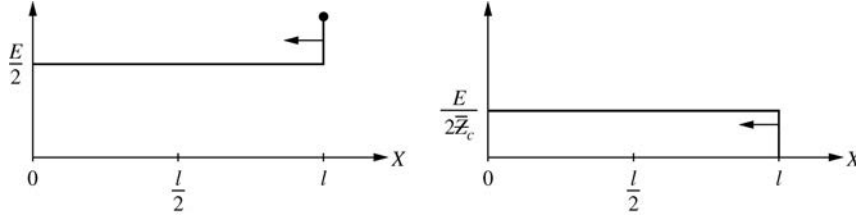

For  $t = 2\tau = \frac{2l}{v}$ :

$$V(x, 2\tau) = \frac{E}{2} U_{-1} \left( \frac{2l-x}{v} \right) + \frac{E}{2} U_{-1} \left( \frac{x}{v} \right) \quad i(x, 2\tau) = \frac{E}{2Z_c} U_{-1} \left( \frac{2l-x}{v} \right) - \frac{E}{2Z_c} U_{-1} \left( \frac{x}{v} \right)$$

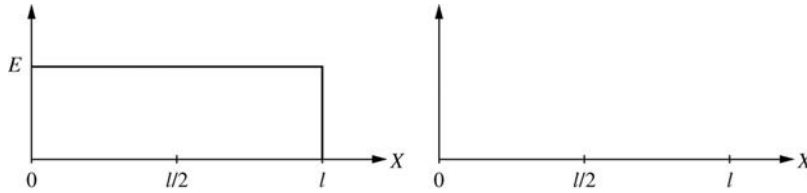

**13.2** From Example 13.2  $\Gamma_R = 1$  and  $\Gamma_S = 0$

For a ramp voltage source,  $E_G(S) = \frac{E}{S^2}$

Then from Eqs (13.2.10) and (13.2.11),

$$V(x, S) = \left( \frac{E}{S^2} \right) \left( \frac{1}{2} \right) \left[ e^{\frac{-Sx}{v}} + e^{S \left( \frac{x}{v} - 2\tau \right)} \right]$$

$$I(x, S) = \left( \frac{E}{S^2} \right) \left( \frac{1}{2Z_c} \right) \left[ e^{\frac{-Sx}{v}} - e^{S \left( \frac{x}{v} - 2\tau \right)} \right]$$

Taking the inverse Laplace transform:

$$V(x, t) = \frac{E}{2} U_{-2} \left( t - \frac{x}{v} \right) + \frac{E}{2} U_{-2} \left( t + \frac{x}{v} - 2\tau \right)$$

$$i(x, t) = \frac{E}{2Z_c} U_{-2} \left( t - \frac{x}{v} \right) - \frac{E}{2Z_c} U_{-2} \left( t + \frac{x}{v} - 2\tau \right)$$

At the center of the line, where  $x = l/2$ ,

$$V\left(\frac{l}{2}, t\right) = \frac{E}{2} U_{-2}\left(t - \frac{\tau}{2}\right) + \frac{E}{2} U_{-2}\left(t - \frac{3\tau}{2}\right)$$

$$i\left(\frac{l}{2}, t\right) = \frac{E}{2Z_c} U_{-2}\left(t - \frac{\tau}{2}\right) - \frac{E}{2Z_c} U_{-2}\left(t - \frac{3\tau}{2}\right)$$

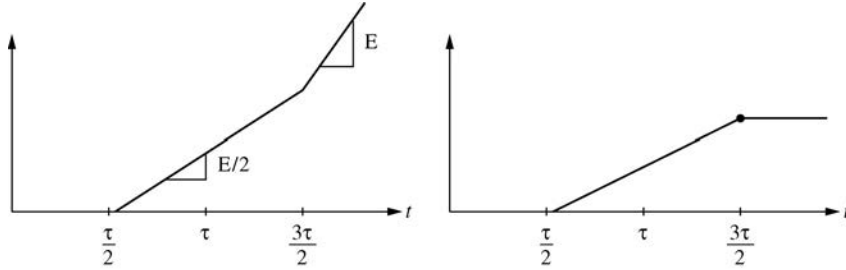

**13.3** From Eq (13.2.12) with  $Z_R = SL_R$  and  $Z_G = Z_c$ :

$$\Gamma_R(S) = \frac{\frac{SL_R}{Z_c} - 1}{\frac{SL_R}{Z_c} + 1} = \frac{S - \frac{Z_c}{L_R}}{S + \frac{Z_c}{L_R}} \quad \Gamma_S(S) = 0$$

Then from Eq (13.2.10) with  $E_G(S) = \frac{E}{S}$

$$V(x, S) = \frac{E}{S} \left( \frac{1}{2} \right) \left[ e^{\frac{-Sx}{v}} + \left( \frac{S - \frac{Z_c}{L_R}}{S + \frac{Z_c}{L_R}} \right) e^{S\left(\frac{x}{v} - 2\tau\right)} \right]$$

Using partial-fraction expansion

$$V(x, S) = \frac{E}{2} \left[ \frac{e^{\frac{-Sx}{v}}}{S} + \left( \frac{-1}{S} + \frac{2}{S + \frac{Z_c}{L_R}} \right) e^{S\left(\frac{x}{v} - 2\tau\right)} \right]$$

Taking the inverse Laplace transform:

$$V(x, t) = \frac{E}{2} U_{-1}\left(t - \frac{x}{v}\right) + \frac{E}{2} \left[ -1 + 2e^{\frac{-1}{L_R Z_c} \left(t + \frac{x}{v} - 2\tau\right)} \right] U_{-1}\left(t + \frac{x}{v} - 2\tau\right)$$

At the center of the line, where  $x = l/2$ :

$$V\left(\frac{l}{2}, t\right) = \frac{E}{2} U_{-1}\left(t - \frac{\tau}{2}\right) + \frac{E}{2} \left[ -1 + 2e^{-\left(\frac{t - \frac{3\tau}{2}}{L_R/Z_c}\right)} \right] U_{-1}\left(t - \frac{3\tau}{2}\right)$$

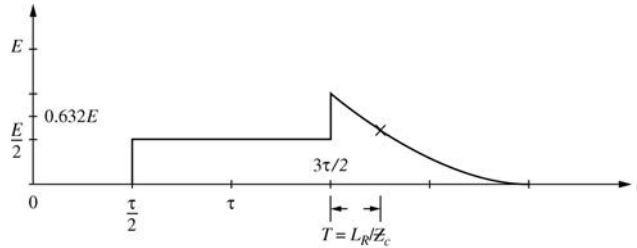

**13.4**  $\Gamma_R = 0$ ;  $E_G(S) = \frac{E}{S}$

From Eq (13.2.10)

$$V(x, S) = \frac{E}{S} \left[ \frac{Z_c/L_G}{S + \frac{Z_c}{L_G}} \right] \left[ e^{-\frac{Sx}{v}} \right]$$

Using partial fraction expansion:

$$V(x, S) = E \left[ \frac{1}{S} - \frac{1}{S + \frac{Z_c}{L_G}} \right] e^{-\frac{Sx}{v}}$$

Taking the inverse Laplace transform,

$$V(x, t) = E \left[ 1 - e^{-\left(\frac{t-x/v}{L_G/Z_c}\right)} \right] U_{-1}\left(t - \frac{x}{v}\right)$$

At the center of the line, where  $x = l/2$ :

$$V\left(\frac{l}{2}, t\right) = E \left[ 1 - e^{-\left(\frac{t-\tau/2}{L_G/Z_c}\right)} \right] U_{-1}\left(t - \tau/2\right)$$

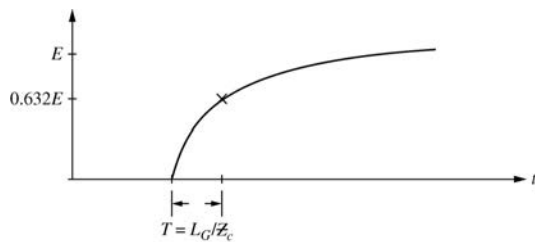

$$13.5 \quad \Gamma_R = \frac{4-1}{4+1} = 0.6 \quad \Gamma_S = \frac{\frac{1}{3}-1}{\frac{1}{3}+1} = -0.5$$

$$E_G(S) = \frac{E}{S}$$

$$V(x, S) = \frac{E}{S} \left[ \frac{1}{\frac{1}{3}+1} \right] \left[ \frac{e^{-\frac{Sx}{v}} + 0.6e^{s\left(\frac{x}{v}-2\tau\right)}}{1-(0.6)(-0.5)e^{-2S\tau}} \right]$$

$$V(x, S) = \frac{3E}{4S} \left[ \frac{e^{-\frac{Sx}{v}} + 0.6e^{s\left(\frac{x}{v}-2\tau\right)}}{1+0.3e^{-2S\tau}} \right]$$

$$V(x, S) = \frac{3E}{4S} \left[ e^{-\frac{Sx}{v}} + 0.6e^{s\left(\frac{x}{v}-2\tau\right)} \right] \left[ 1 - 0.3e^{-2S\tau} + (0.3)^2 e^{-4S\tau} \dots \right]$$

$$V(x, S) = \frac{3E}{4S} \left[ e^{-\frac{Sx}{v}} + 0.6e^{s\left(\frac{x}{v}-2\tau\right)} - 0.3e^{-s\left(\frac{x}{v}+2\tau\right)} - 0.18e^{s\left(\frac{x}{v}-4\tau\right)} \right. \\ \left. + 0.09e^{-s\left(\frac{x}{v}+4\tau\right)} + 0.054e^{s\left(\frac{x}{v}-6\tau\right)} \dots \right]$$

$$V(x, t) = \frac{3E}{4} \left[ U_{-1} \left( t - \frac{x}{v} \right) + 0.6U_{-1} \left( t + \frac{x}{v} - 2\tau \right) \right. \\ \left. - 0.3U_{-1} \left( t - \frac{x}{v} - 2\tau \right) - 0.18U_{-1} \left( t + \frac{x}{v} - 4\tau \right) \right. \\ \left. + 0.09U_{-1} \left( t - \frac{x}{v} - 4\tau \right) + 0.054U_{-1} \left( t + \frac{x}{v} - 6\tau \right) \dots \right]$$



At the center of the line, where  $x = \frac{l}{2}$ :

$$V\left(\frac{l}{2}, t\right) = \frac{3E}{4} \left[ U_{-1}\left(t - \frac{\tau}{2}\right) + 0.6U_{-1}\left(t - \frac{3\tau}{2}\right) - 0.3U_{-1}\left(t - \frac{5\tau}{2}\right) \right. \\ \left. - 0.18U_{-1}\left(t - \frac{7\tau}{2}\right) + 0.09U_{-1}\left(t - \frac{9\tau}{2}\right) + 0.054U_{-1}\left(t - \frac{11\tau}{2}\right) \dots \right]$$

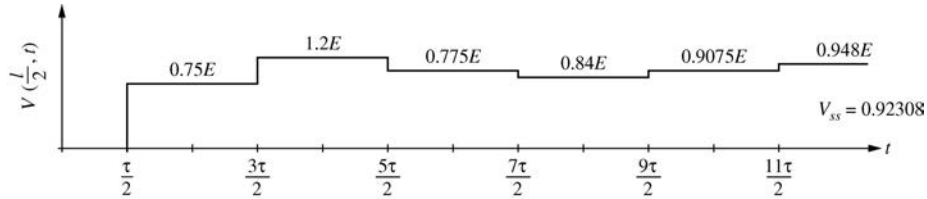

13.6 (a)  $Z_c = \sqrt{\frac{L}{C}} = \sqrt{\frac{\frac{1}{3} \times 10^{-6}}{\frac{1}{3} \times 10^{-10}}} = 100 \Omega$

$$V = \frac{1}{\sqrt{LC}} = \frac{1}{\sqrt{\left(\frac{1}{3} \times 10^{-6}\right)\left(\frac{1}{3} \times 10^{-10}\right)}} = 3.0 \times 10^8 \text{ m/s}$$

$$\tau = \frac{l}{v} = \frac{30 \times 10^3}{3 \times 10^8} = 1 \times 10^{-4} \text{ s} = 0.1 \text{ ms}$$

(b)  $\Gamma_S = \frac{\frac{Z_G}{Z_c} - 1}{\frac{Z_G}{Z_c} + 1} = 0 \quad E_G(S) = \frac{100}{S}$

$$Z_R(S) = \frac{R(SL)}{SL + R} = \frac{RS}{S + \frac{R}{L}} = \frac{100S}{S + 50,000}$$

$$\Gamma_R(S) = \frac{\frac{Z_R(S)}{Z_c} - 1}{\frac{Z_R(S)}{Z_c} + 1} = \frac{\frac{S}{S + 50,000} - 1}{\frac{S}{S + 50,000} + 1} = \frac{-50,000}{2S + 50,000}$$

$$\Gamma_R(S) = \frac{-25,000}{S + 25,000} \text{ per unit}$$

(c) Using (13.2.11) with  $x=l$  (receiving end)

$$I_R(S) = I(l, S) = \left[ \frac{100/S}{200} \right] \left[ e^{-S\tau} + \frac{25000}{S+25000} e^{-S\tau} \right]$$

$$I_R(S) = \frac{1}{2} \left[ \frac{1}{S} + \frac{25000}{S(S+25000)} \right] e^{-S\tau} = \frac{1}{2} \left[ \frac{1}{S} + \frac{1}{S} + \frac{-1}{S+25000} \right] e^{-S\tau}$$

$$I_R(S) = \frac{1}{2} \left[ \frac{2}{S} + \frac{-1}{S+25000} \right] e^{-S\tau}$$

$$i_R(t) = \frac{1}{2} \left[ 2 - e^{\frac{-(t-\tau)}{0.04 \times 10^{-3}}} \right] U_{-1}(t-\tau) \text{ A}$$

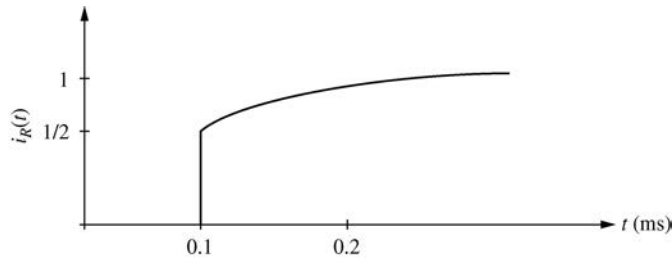

13.7 (a)  $Z_c = \sqrt{\frac{L}{C}} = \sqrt{\frac{2 \times 10^{-6}}{1.25 \times 10^{-11}}} = 400 \Omega$

$$w = \frac{1}{\sqrt{LC}} = \frac{1}{\sqrt{(2 \times 10^{-6})(1.25 \times 10^{-11})}} = 2.0 \times 10^8 \frac{\text{m}}{\text{s}}$$

$$\tau = \frac{l}{v} = \frac{100 \times 10^3}{2 \times 10^8} = 5 \times 10^{-4} \text{ s} = 0.5 \text{ ms}$$

(b)  $\Gamma_S = \frac{\frac{Z_G}{Z_c} - 1}{\frac{Z_G}{Z_c} + 1} = 0 \quad E_G(S) = \frac{100}{S}$

$$Z_R(S) = SL_R + \frac{1}{SC_R} \quad L_R = 100 \times 10^{-3} \text{ H}$$

$$C_R = 1 \times 10^{-6} \text{ F}$$

$$\Gamma_R(S) = \frac{\frac{Z_R(S)}{Z_c} - 1}{\frac{Z_R(S)}{Z_c} + 1} = \frac{S \frac{L_R}{Z_c} + \frac{1}{SC_R Z_c} - 1}{S \frac{L_R}{Z_c} + \frac{1}{SC_R Z_c} + 1}$$

$$\Gamma_R(S) = \frac{S^2 - \frac{Z_c}{L_R} S + \frac{1}{L_R C_R}}{S^2 + \frac{Z_c}{L_R} S + \frac{1}{L_R C_R}} = \frac{S^2 - 4 \times 10^3 S + 1 \times 10^7}{S^2 + 4 \times 10^3 S + 1 \times 10^7}$$

(c) Using (13.2.10) with  $x = l$  (receiving end)

$$V_R(S) = \frac{100}{S} \left( \frac{400}{400 + 400} \right) \left[ e^{-S\tau} + \left( \frac{S^2 - 4 \times 10^3 S + 1 \times 10^7}{S^2 + 4 \times 10^3 S + 1 \times 10^7} \right) e^{-S\tau} \right]$$

$$V_R(S) = 50 \left[ \frac{1}{S} + \frac{(S - 2000 + j2449.5)(S - 2000 - j2449.5)}{S(S + 2000 + j2449.5)(S + 2000 - j2449.5)} \right] e^{-S\tau}$$

$$V_R(S) = 50 \left[ \frac{1}{S} + \frac{1}{S} + \frac{-j1.633}{S + 2000 + j2449.5} + \frac{+j1.633}{S + 2000 - j2449.5} \right] e^{-S\tau}$$

$$V_R(S) = 50 \left[ \frac{2}{S} + \frac{-3.266(2449.5)}{(S + 2000)^2 + (2449.5)^2} \right] e^{-S\tau}$$

$$V_R(t) = 50 \left\{ 2 - 3.266 e^{\frac{-(t-\tau)}{0.5 \times 10^{-3}}} \sin[(2449.5)(t - \tau)] \right\} U_{-1}(t - \tau)$$

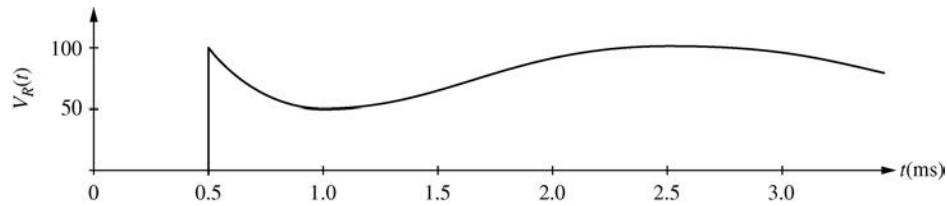

13.8 (a)  $Z_c = \sqrt{\frac{L}{C}} = \sqrt{\frac{0.999 \times 10^{-6}}{1.112 \times 10^{-11}}} = \underline{\underline{299.73 \Omega}}$

$$w = \frac{1}{\sqrt{LC}} = \frac{1}{\sqrt{(0.999 \times 10^{-6})(1.112 \times 10^{-11})}} = \underline{\underline{3.0 \times 10^8 \frac{\text{m}}{\text{s}}}}$$

$$\tau = \frac{l}{v} = \frac{60 \times 10^3}{3.0 \times 10^8} = 1.9998 \times 10^{-4} \text{ s} = \underline{\underline{0.2 \text{ ms}}}$$

(b)  $\Gamma_S = \frac{\frac{Z_G}{Z_c} - 1}{\frac{Z_G}{Z_c} + 1} = 0 \quad E_G(S) = \frac{E}{S^2}$

$$Z_R = \frac{R_R \left( \frac{1}{SC_R} \right)}{R_R + \frac{1}{SC_R}} = \frac{(1/C_R)}{S + \frac{1}{R_R C_R}} \quad \begin{array}{l} R_R = 150 \Omega \\ C_R = 1 \times 10^{-6} \text{ F} \end{array}$$

$$\Gamma_R = \frac{\frac{Z_R}{Z_c} - 1}{\frac{Z_R}{Z_c} + 1} = \frac{\frac{\left(\frac{1}{Z_c C_R}\right) - 1}{S + \frac{1}{R_R C_R}}}{\frac{\left(\frac{1}{Z_c C_R}\right) + 1}{S + 1/R_x C_R}}$$

$$\Gamma_R = \frac{-S - \left(\frac{1}{R_R C_R} - \frac{1}{Z_c C_R}\right)}{S + \left(\frac{1}{R_R C_R} + \frac{1}{Z_c C_R}\right)} = \frac{-S - 3.330 \times 10^3}{S + 1.0003 \times 10^4} \text{ per unit}$$

(c) Using (13.2.10) with  $x = 0$  (sending end)

$$V(0, S) = V_s(S) = \frac{E}{S^2} \left( \frac{1}{2} \right) \left[ 1 + \left( \frac{-S - 3.33 \times 10^3}{S + 1.0003 \times 10^4} \right) e^{-2S\tau} \right]$$

$$V_s(S) = \frac{E}{2} \left( \frac{1}{S^2} + \frac{-S - 3.33 \times 10^3}{S^2 (S + 1.0003 \times 10^4)} e^{-2S\tau} \right)$$

$$V_s(S) = \frac{E}{2} \left[ \frac{1}{S^2} + \left( \frac{-0.333}{S^2} + \frac{-6.67 \times 10^{-5}}{S} + \frac{6.67 \times 10^{-5}}{S + 1.0003 \times 10^4} \right) e^{-2S\tau} \right]$$

(d)  $V_s(t)$

$$= \frac{E}{2} \left\{ t U_{-1}(t) - \left[ 0.333(t - 2\tau) + 6.69 \times 10^{-5} - 6.67 \times 10^{-5} e^{\frac{-(t-2\tau)}{0.1 \times 10^{-3}}} \right] U_{-1}(t - 2\tau) \right\}$$

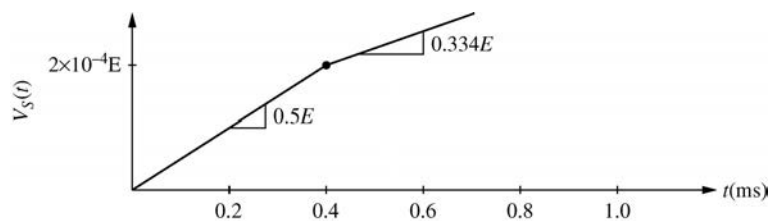

13.9

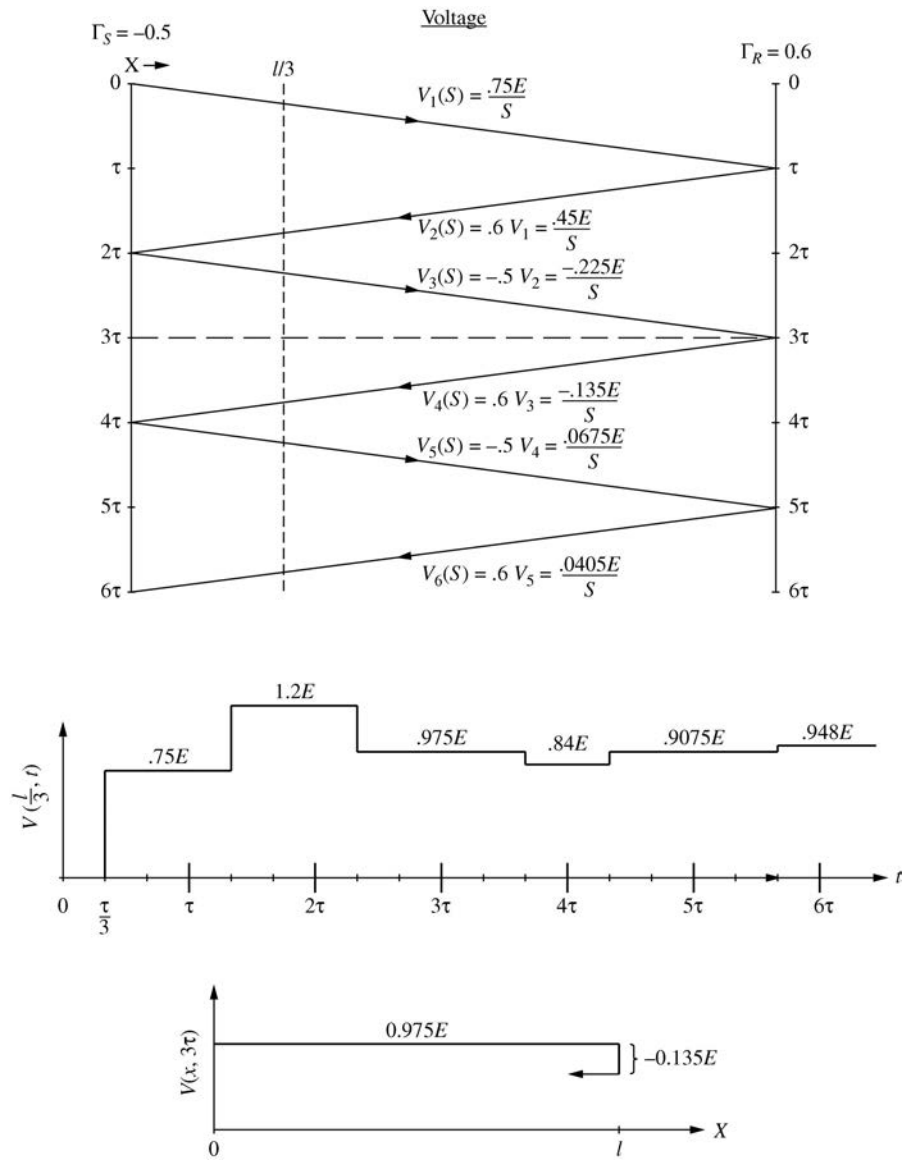

13.10

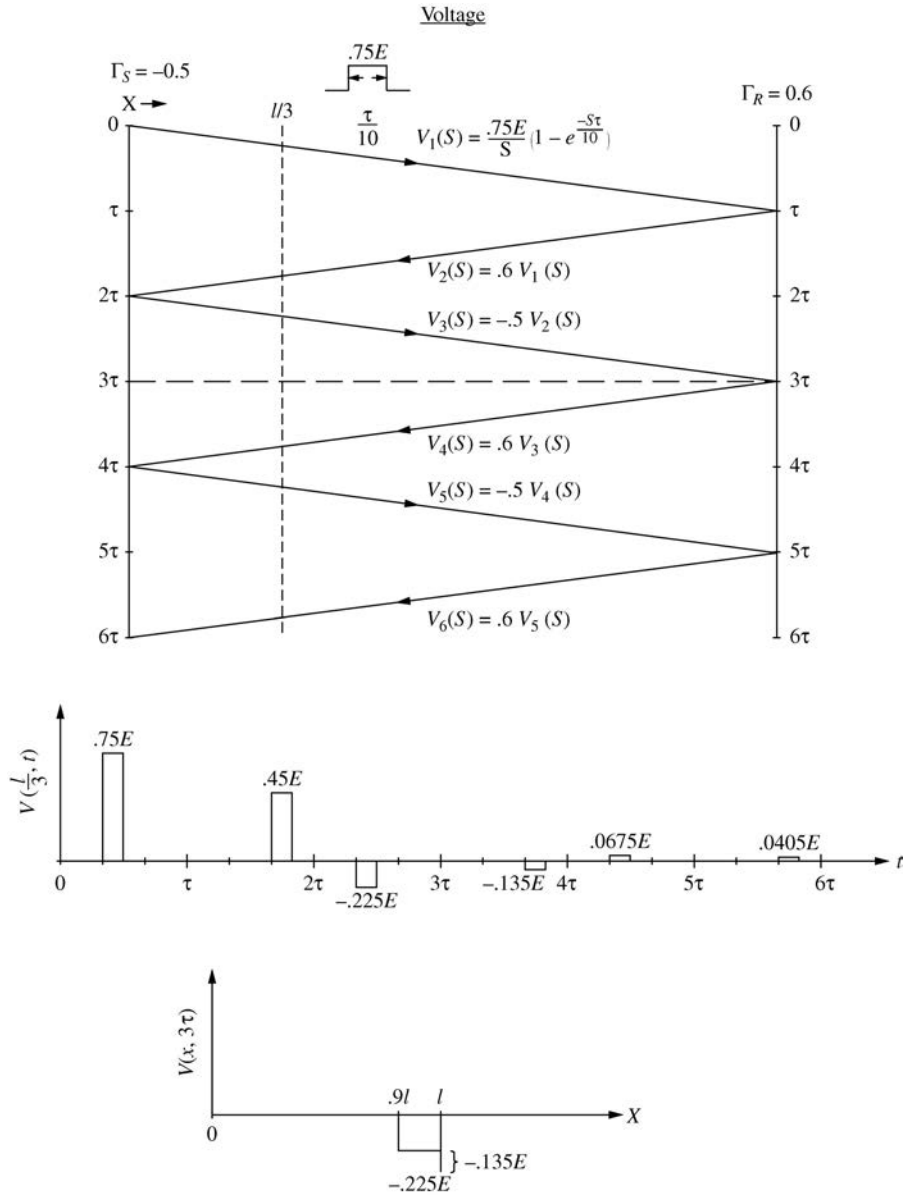

13.11

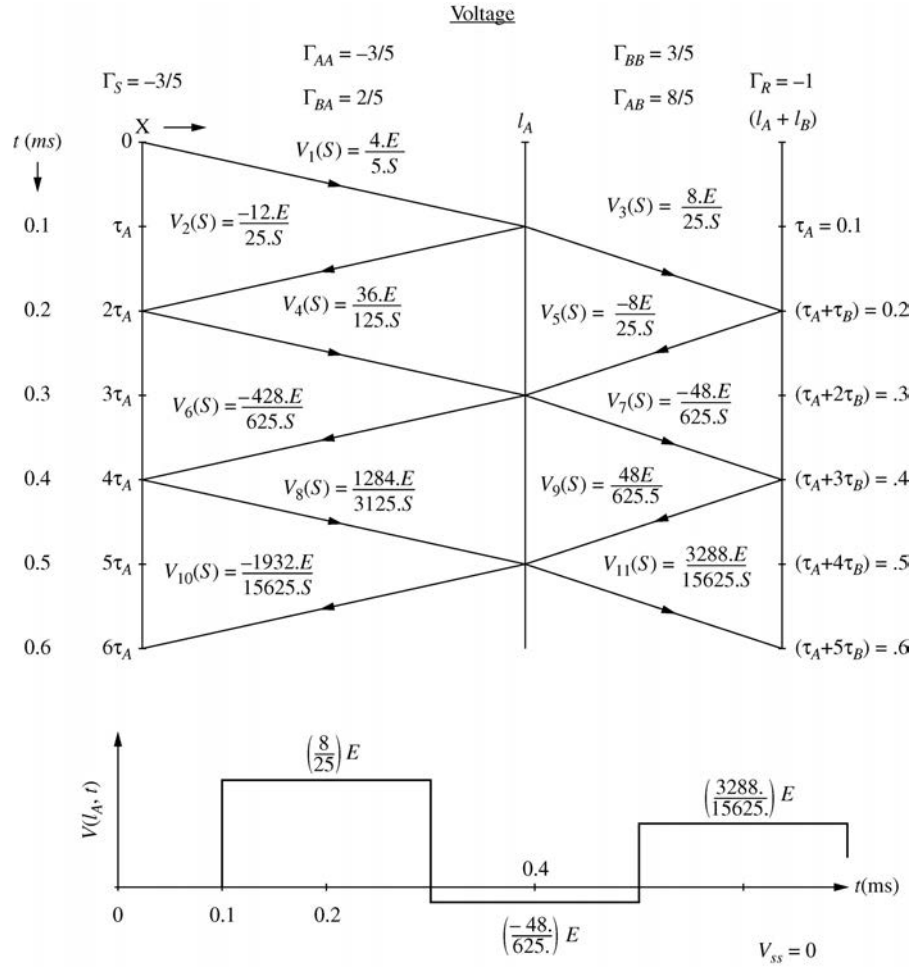

13.12

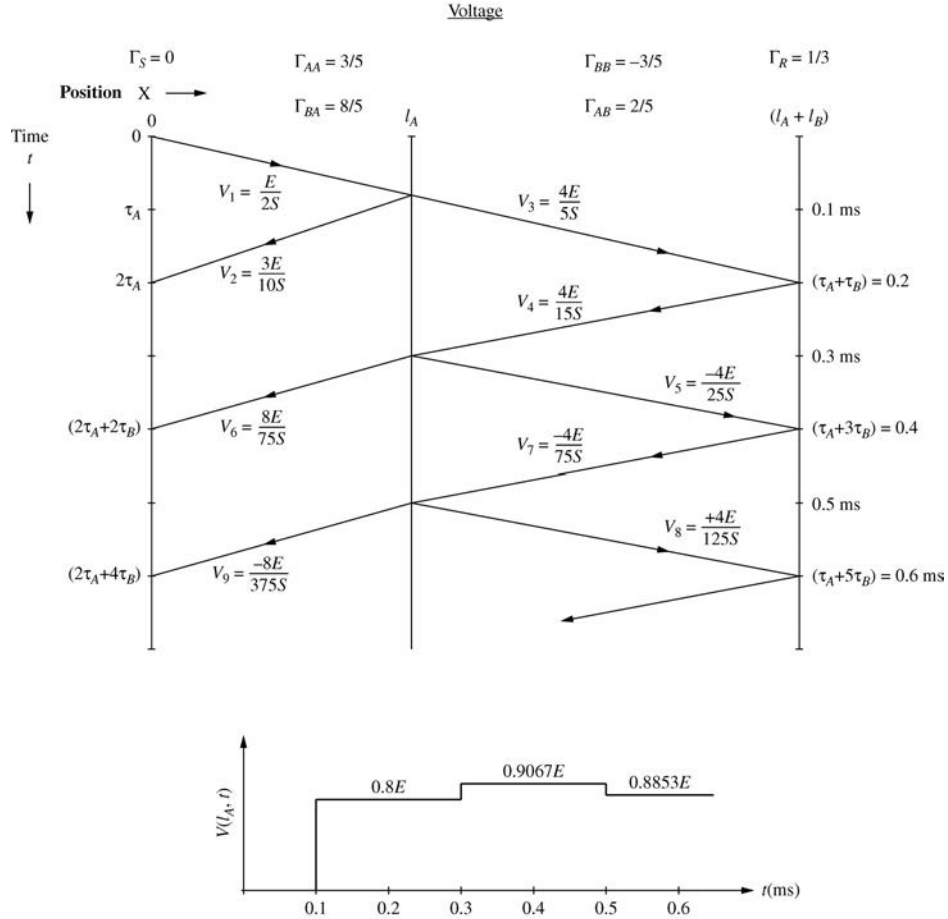

13.13

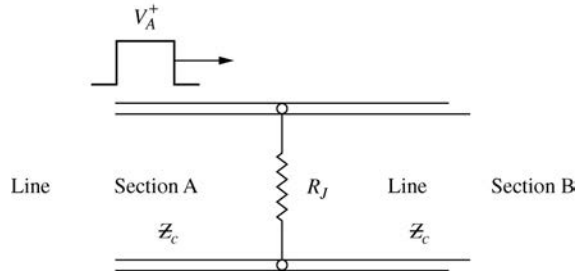

For a voltage wave  $V_A^+$  arriving at the junction:

$$KVL: V_A^+ + V_A^- = V_B^+ \quad (1)$$

$$KCL: I_A^+ + I_A^- = I_B^+ + \frac{V_B^+}{R_J}$$

$$\frac{V_A^+}{Z_c} - \frac{V_A^-}{Z_c} = \frac{V_B^+}{Z_c} + \frac{V_B^+}{R_J} = V_B^+ \left( \frac{1}{Z_c} + \frac{1}{R_J} \right) = \frac{V_B^+}{Z_{eq}} \quad (2)$$

where  $Z_{eq} = \frac{R_J Z_c}{R_J + Z_c}$



Solving (1) and (2):

$$V_A^- = \begin{pmatrix} \frac{Z_{eq} - 1}{Z_c} \\ \frac{Z_{eq} + 1}{Z_c} \end{pmatrix} V_A^+ = \Gamma_{AA} V_A^+ \quad V_B^+ = \begin{pmatrix} 2 \left( \frac{Z_{eq}}{Z_c} \right) \\ \frac{Z_{eq} + 1}{Z_c} \end{pmatrix} V_A^+ = \Gamma_{BA} V_A^+$$

Since Line Sections A and B have the same characteristic impedance  $Z_c$ ,  $\Gamma_{BB} = \Gamma_{AA}$  and  $\Gamma_{AB} = \Gamma_{BA}$ .

$$\tau = \frac{\ell}{w} = \frac{100 \times 10^3}{3 \times 10^8} = \frac{1}{3} \text{ms}$$

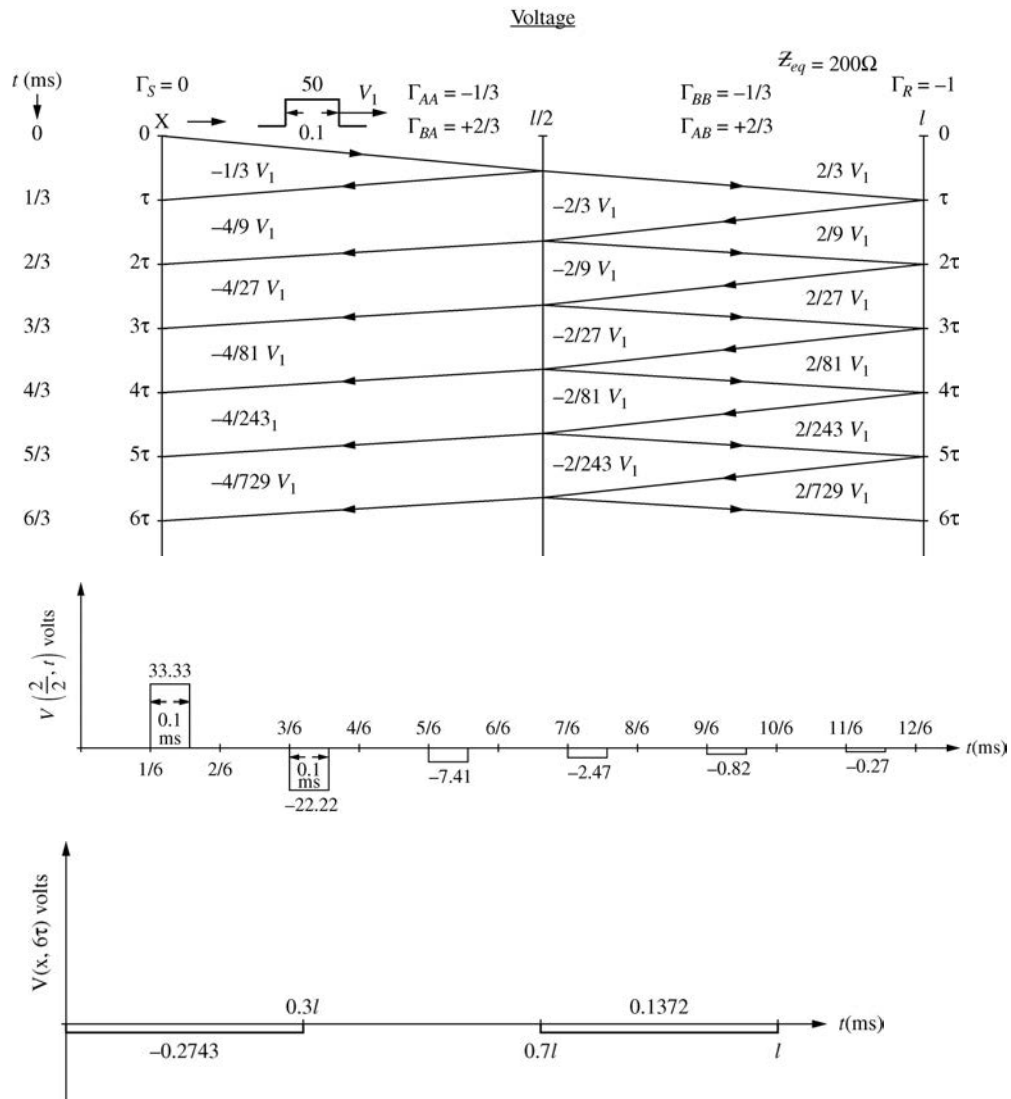

**13.14** For a voltage wave  $V_A^+$  arriving at the junction from line A,

$$\text{KVL } V_A^+ + V_A^- = V_B^+ \quad (1)$$

$$V_B^+ = V_C^+ \quad (2)$$

$$V_B^+ = V_D^+ \quad (3)$$

$$\text{KCL } I_A^+ + I_A^- = I_B^+ + I_C^+ + I_D^+$$

$$\frac{V_A^+}{Z_A} - \frac{V_A^-}{Z_A} = \frac{V_B^+}{Z_B} + \frac{V_C^+}{Z_C} + \frac{V_D^+}{Z_D} \quad (4)$$

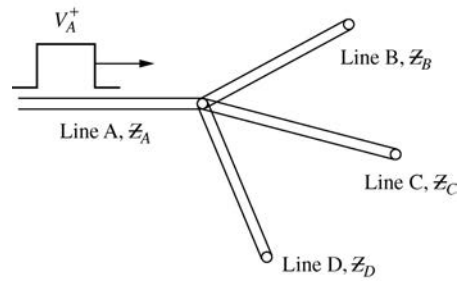

Using Eqs (2) and (3) in Eq (4):

$$\frac{V_A^+}{Z_A} - \frac{V_A^-}{Z_A} = V_B^+ \left( \frac{1}{Z_B} + \frac{1}{Z_C} + \frac{1}{Z_D} \right) = \frac{V_B^+}{Z_{eq}} \quad (5)$$

$$\text{Where } Z_{eq} = Z_B // Z_C // Z_D = \frac{1}{\frac{1}{Z_B} + \frac{1}{Z_C} + \frac{1}{Z_D}}$$

Solving Eqs (1) and (5):

$$V_A^- = \left[ \frac{\frac{Z_{eq}}{Z_A} - 1}{\left(\frac{Z_{eq}}{Z_A}\right) + 1} \right] V_A^+ = \Gamma_{AA} V_A^+ \quad V_B^+ = \left[ \frac{2\left(\frac{Z_{eq}}{Z_A}\right)}{\left(\frac{Z_{eq}}{Z_A}\right) + 1} \right] V_A^+ = \Gamma_{BA} V_A^+$$

$$\text{Also } V_C^+ = \Gamma_{CA} V_A^+ \quad V_D^+ = \Gamma_{DA} V_A^+ \quad \Gamma_{CA} = \Gamma_{DA} = \Gamma_{BA}$$

$$\mathbf{13.15} \quad \Gamma_S(S) = \frac{\frac{SL_G}{Z_c} - 1}{\frac{SL_G}{Z_c} + 1} = \frac{S - Z_c/L_G}{S + Z_c/L_G} \quad \Gamma_R = \frac{\frac{1}{4} - 1}{\frac{1}{4} + 1} = \frac{-3}{5}$$

$$V_1(S) = \frac{E}{S} \left( \frac{Z_c}{SL_G + Z_c} \right) = E \left( \frac{1}{S} - \frac{1}{S + \frac{Z_c}{L_G}} \right)$$

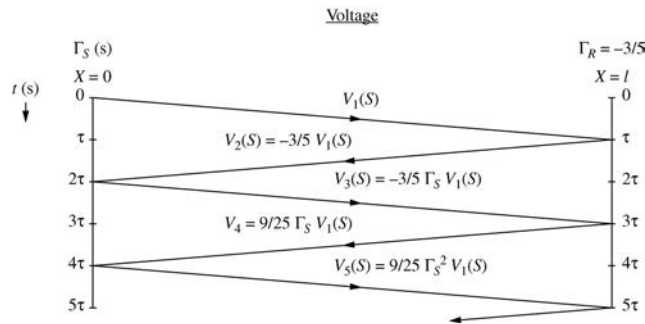

For  $0 \leq t \leq 5\tau$ :

$$V(l, S) = \left(1 - \frac{3}{5}\right) V_1(S) e^{-S\tau} + \left(\frac{-3}{5} + \frac{9}{25}\right) \Gamma_S(S) V_1(S) e^{-S(3\tau)}$$

$$V(l, S) = \frac{2E}{5} \left( \frac{1}{S} - \frac{1}{S + \frac{Z_c}{L_G}} \right) e^{-S\tau} - \frac{6E}{25} \left( \frac{1}{S} \right) \left( \frac{S - Z_c/L_G}{S + Z_c/L_G} \right) \left( \frac{Z_c/L_G}{S + Z_c/L_G} \right) e^{-S(3\tau)}$$

$$V(l, S) = \frac{2E}{5} \left( \frac{1}{S} - \frac{1}{S + \frac{Z_c}{L_G}} \right) e^{-S\tau} + \frac{6E}{25} \left( \frac{1}{S} - \frac{1}{S + \frac{Z_c}{L_G}} - \frac{2Z_c/L_G}{\left(S + \frac{Z_c}{L_G}\right)^2} \right) e^{-S(3\tau)}$$

Taking the inverse Laplace transform:

$$V(l, t) = \frac{2E}{5} \left( 1 - e^{-\frac{t-\tau}{L_G/Z_c}} \right) U_{-1}(t-\tau) + \frac{6E}{25} \left( 1 - e^{-\frac{t-3\tau}{L_G/Z_c}} - \frac{2(t-3\tau)}{L_G/Z_c} e^{-\frac{t-3\tau}{L_G/Z_c}} \right) U_{-1}(t-3\tau)$$

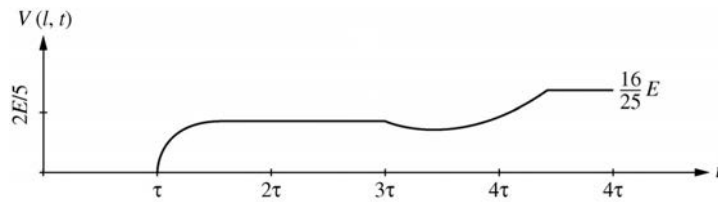

13.16 (a)

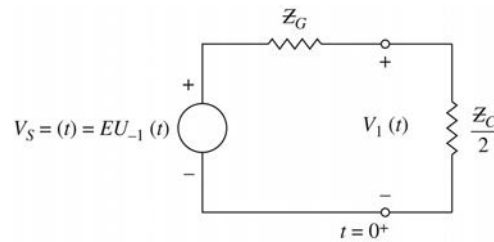

$$\begin{aligned} Z_G &= 100 \Omega \\ Z_c &= 400 \Omega \\ E &= 100 \text{ kV} \end{aligned}$$

$$V_1(t) = E U_{-1}(t) \left[ \frac{\frac{Z_c}{2}}{\frac{Z_c}{2} + Z_G} \right] = 100 \left( \frac{200}{200 + 100} \right) U_{-1}(t)$$

$$V_1(t) = 66.67 U_{-1}(t) \text{ kV}$$

$$(b) \Gamma_S = \frac{\frac{Z_G}{(Z_c/2)} - 1}{\frac{Z_G}{(Z_c/2)} + 1} = \frac{\frac{100}{200} - 1}{\frac{100}{200} + 1} = -\frac{1}{3} \quad \Gamma_R = -1$$

(c)

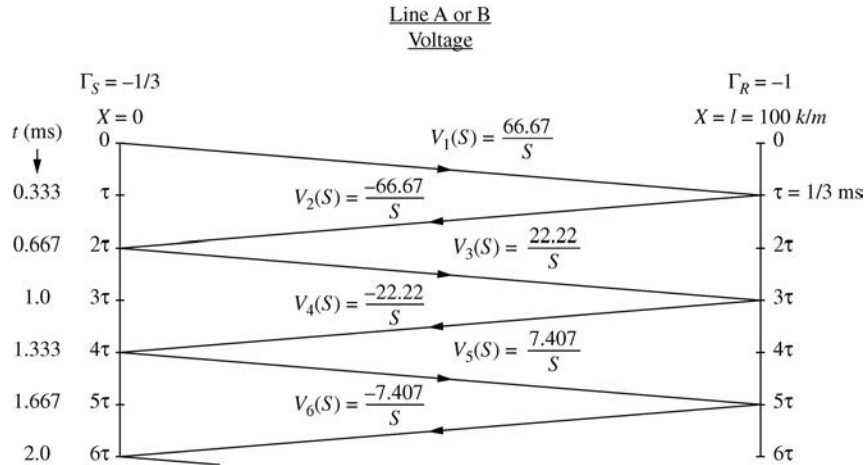

(d)

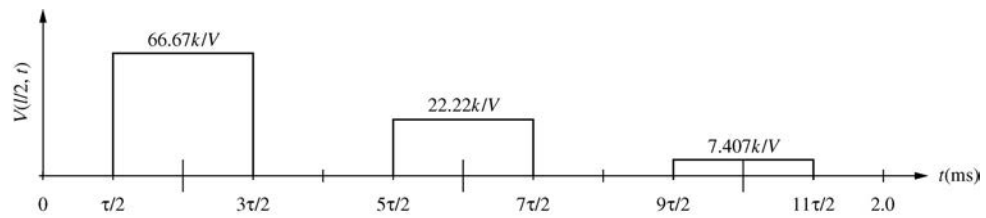

$$13.17 (a) \quad \Gamma_S = \frac{\frac{400}{200} - 1}{\frac{400}{200} + 1} = \frac{1}{3} \quad \Gamma_R = \frac{\frac{100}{300} - 1}{\frac{100}{300} + 1} = -\frac{1}{2}$$

$$\Gamma_{AA} = \frac{\frac{300}{200} - 1}{\frac{300}{200} + 1} = \frac{1}{5} \quad \Gamma_{BA} = \frac{2\left(\frac{300}{200}\right)}{\frac{300}{200} + 1} = \frac{6}{5}$$

$$\Gamma_{BB} = \frac{\frac{200}{300} - 1}{\frac{200}{300} + 1} = -\frac{1}{5} \quad \Gamma_{AB} = \frac{2\left(\frac{200}{300}\right)}{\frac{200}{300} + 1} = \frac{4}{5}$$

(b) Voltage

$$\Gamma_S = \frac{1}{3} \quad \Gamma_{AA} = \frac{1}{5} \quad \Gamma_{BB} = -\frac{1}{5} \quad \Gamma_R = -\frac{1}{2}$$

$$\Gamma_{BA} = \frac{6}{5} \quad \Gamma_{AB} = \frac{4}{5}$$

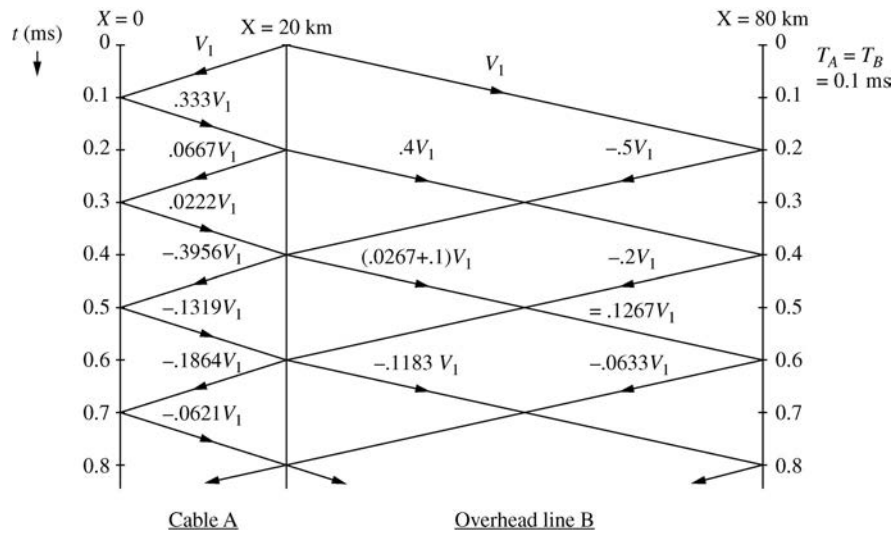

At  $t = 0$ , the 10 kA pulsed current source at the junction encounters  $200 // 300 = 120 \Omega$ . Therefore the first voltage waves, which travel on both the cable and overhead line, are pulses of width  $50 \mu s$  and magnitude  $10 \text{ kA} \times 120 \Omega = 1200 \text{ kV}$ ,

$$V_1(s) = \frac{E}{s} (1 - e^{-Ts}) \quad E = 1200. \text{ kV} \quad T = 50. \mu s$$

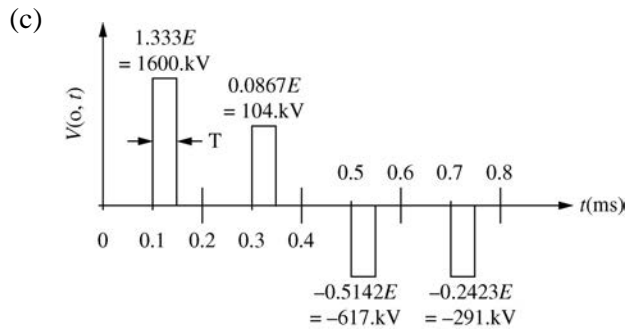

13.18

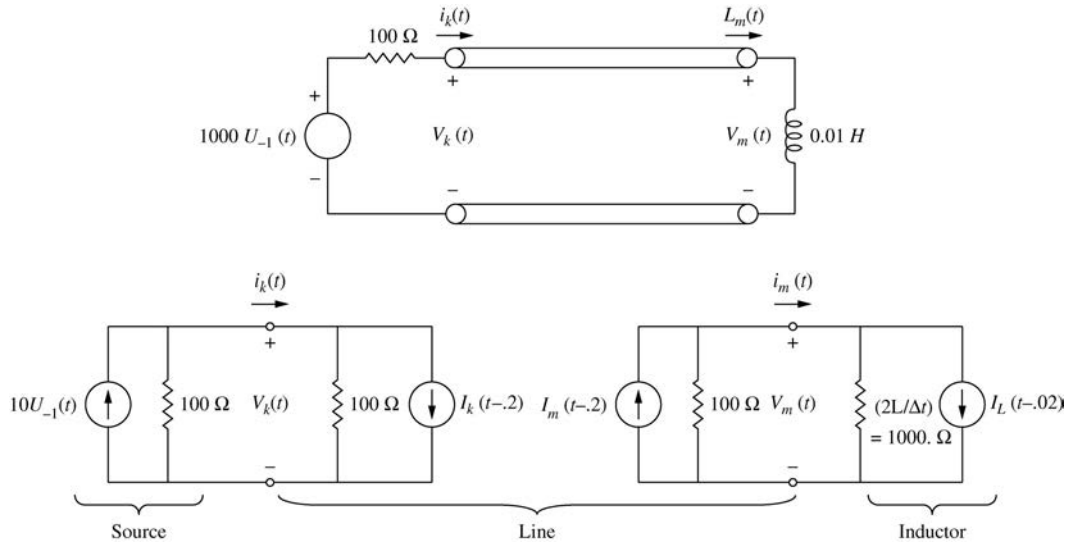

Nodal Equations: Note that  $\tau = 0.2$  ms and  $\Delta t = 0.02$  ms

$$0.02 V_k(t) = 10 - I_k(t - 0.2)$$

$$0.011 V_m(t) = I_m(t - 0.2) - I_L(t - 0.02)$$

Solving:

$$V_k(t) = 50.0 [10 - I_k(t - 0.2)] \tag{a}$$

$$V_m(t) = 90.909 [I_m(t - 0.2) - I_L(t - 0.02)] \tag{b}$$

Dependent current sources:

$$\text{Eq (12.4.10)} \quad I_k(t) = I_m(t - 0.2) - \frac{2}{100} V_m(t) \tag{c}$$

$$\text{Eq (12.4.9)} \quad I_m(t) = I_k(t - 0.2) + \frac{2}{100} V_k(t) \tag{d}$$

$$\text{Eq (12.4.14)} \quad I_L(t) = I_L(t - 0.02) + \frac{V_m(t)}{500} \tag{e}$$

Equations (a) – (e) can now be solved iteratively by digital computer for time  $t = 0, 0.02, 0.04 \dots$  ms. Note that  $I_k( )$  and  $I_m( )$  on the right hand side of Eqs (a) – (e) are zero during the first 10 iterations while their arguments ( ) are negative.

13.19

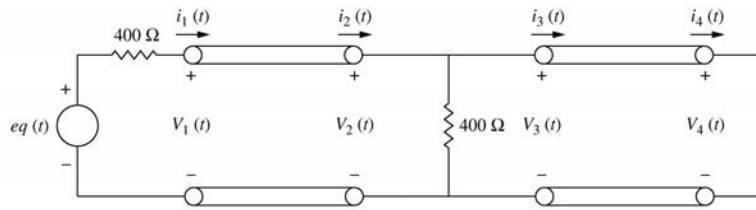

$$eq(t) = 100 [U_{-1}(t) - U_{-1}(t-0.1)]$$

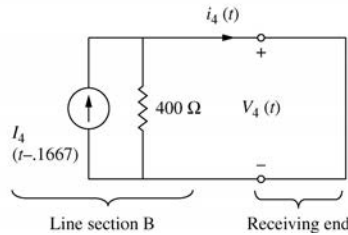
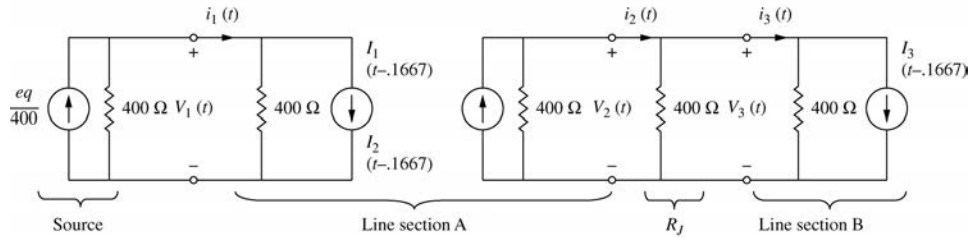

Nodal Equations:

$$V_1(t) = 200 \left[ \frac{1}{4} - \frac{1}{4} U_{-1}(t-0.1) - I_1(t-.1667) \right] \quad (a)$$

$$V_2(t) = 133.33 [I_2(t-.1667) - I_3(t-.1667)] \quad (b)$$

$$V_3(t) = V_2(t) \quad (c)$$

$$V_4(t) = 0 \quad (d)$$

Dependent current sources:

$$\text{Eq (12.4.10)} \quad I_1(t) = I_2(t-.1667) - \left( \frac{2}{400} \right) V_2(t) \quad (e)$$

$$\text{Eq (12.4.9)} \quad I_2(t) = I_1(t-.1667) + \left( \frac{2}{400} \right) V_1(t) \quad (f)$$

$$\text{Eq (12.4.10)} \quad I_3(t) = I_4(t-.1667) - \left( \frac{2}{400} \right) V_4(t) \quad (g)$$

$$\text{Eq (12.4.9)} \quad I_4(t) = I_3(t-.1667) + \left( \frac{2}{400} \right) V_3(t) \quad (h)$$

Equations (a) – (h) can be solved iteratively for  $t = 0, \Delta t, 2\Delta t \dots$  where  $\Delta t = 0.03333 \text{ ms}$ .

$I_1(\ ), I_2(\ ), I_3(\ )$  and  $I_4(\ )$  on the right hand side of Eqs (a) – (h) are zero for the first 5 iterations.

**13.20**

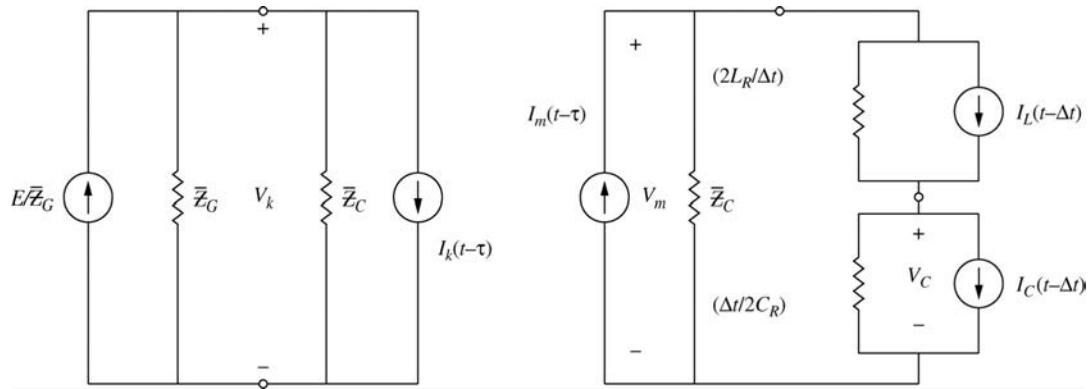

$$E = 100. \text{kV} \quad Z_G = Z_C = 400. \Omega \quad = 500. \mu \text{s}$$

$$\Delta t = 100. \mu \text{s} \quad (2L_R / \Delta t) = 2000. \Omega \quad \left( \frac{\Delta t}{2C_R} \right) = 50. \Omega$$

Nodal equations:

$$\begin{bmatrix} \left( \frac{1}{400} + \frac{1}{400} \right) & 0 & 0 \\ 0 & \left( \frac{1}{400} + \frac{1}{2000} \right) & \frac{-1}{2000} \\ 0 & \frac{-1}{2000} & \left( \frac{1}{50} + \frac{1}{2000} \right) \end{bmatrix} \begin{bmatrix} V_k(t) \\ V_m(t) \\ V_c(t) \end{bmatrix} = \begin{bmatrix} \frac{1}{4} - I_k(t-500) \\ I_m(t-500) - I_L(t-100) \\ I_L(t-100) + I_C(t-100) \end{bmatrix}$$

Solving:

$$V_k(t) = 200 \left[ \frac{1}{4} - I_k(t-500) \right]$$

$$\begin{bmatrix} V_m(t) \\ V_c(t) \end{bmatrix} = \begin{bmatrix} 334.7 & 8.136 \\ 8.136 & 48.98 \end{bmatrix} \begin{bmatrix} I_m(t-500) - I_L(t-100) \\ I_L(t-100) + I_C(t-100) \end{bmatrix}$$



Current sources:

$$(12.4.9) \quad I_m(t) = I_k(t - 500) + \left(\frac{2}{400}\right)V_k(t)$$

$$(12.4.10) \quad I_k(t) = I_m(t - 500) - \left(\frac{2}{400}\right)V_m(t)$$

$$(12.4.14) \quad I_L(t) = I_L(t - 100) + \frac{1}{1000}[V_m(t) - V_C(t)]$$

$$(12.4.18) \quad I_C(t) = -I_C(t - 100) + \left(\frac{1}{25}\right)V_C(t)$$

t	$V_k$	$V_m$	$V_C$	$I_m$	$I_k$	$I_L$	$I_C$
$\mu s$	kV	kV	kV	kA	kA	kA	kA
0	50.0	0	0	0.25	0	0	0
100	50.0	0	0	0.25	0	0	0
200	50.0	0	0	0.25	0	0	0
300	50.0	0	0	0.25	0	0	0
400	50.0	0	0	0.25	0	0	0
500	50.0	83.68	2.034	0.25	0.2398	0.0816	0.0814
600	50.0	57.69		0.25			

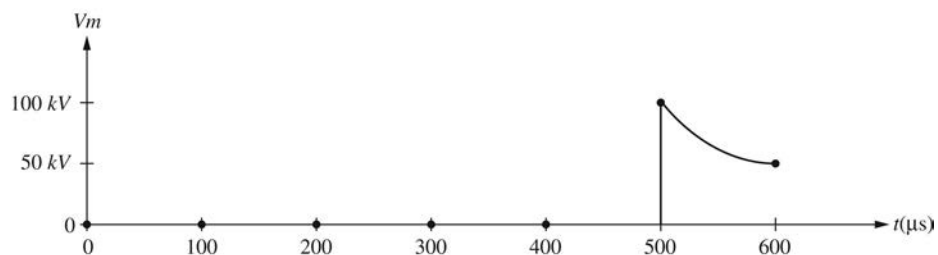
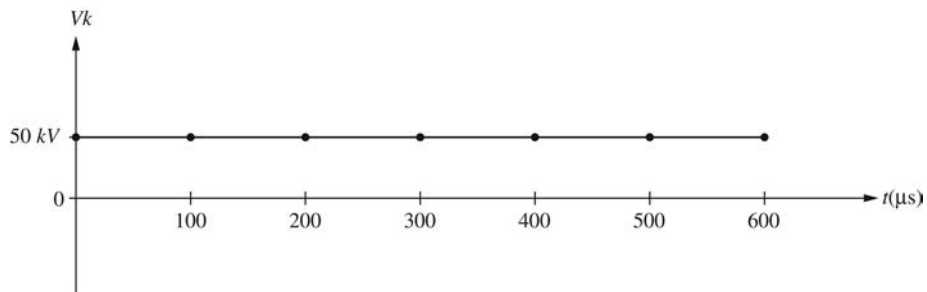

13.21

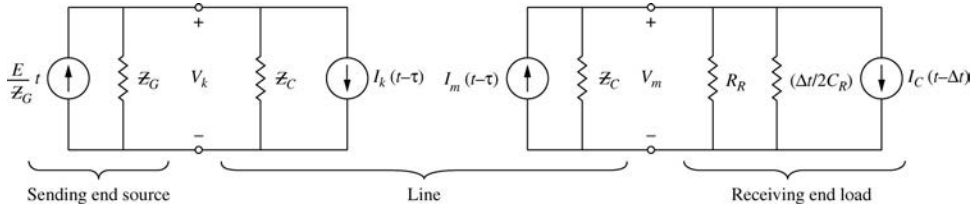

$$E = 100. \text{ kV} \quad Z_G = Z_C = 299.73 \, \Omega \quad R_R = 150 \, \Omega$$

$$\Delta t = 50. \mu\text{s} \quad \uparrow = 200. \mu\text{s} \quad \left( \frac{\Delta t}{2C_R} \right) = 25. \, \Omega$$

Writing nodal equations:

$$\begin{bmatrix} \left( \frac{1}{299.73} + \frac{1}{299.73} \right) & 0 \\ 0 & \left( \frac{1}{299.73} + \frac{1}{150.} + \frac{1}{25.} \right) \end{bmatrix} \begin{bmatrix} V_k(t) \\ V_m(t) \end{bmatrix} = \begin{bmatrix} \frac{t}{2.9973} - I_k(t-200) \\ I_m(t-200) + I_C(t-50) \end{bmatrix}$$

Solving:

$$V_k(t) = 50.t - 149.865 I_k(t-200)$$

$$V_m(t) = 19.999 [I_m(t-200) + I_C(t-50)]$$

Current sources:

$$(12.4.9) \quad I_m(t) = I_k(t-200) + \left( \frac{2}{299.73} \right) V_k(t)$$

$$(12.4.10) \quad I_k(t) = I_m(t-200) - \left( \frac{2}{299.73} \right) V_m(t)$$

$$(12.4.18) \quad I_C(t) = -I_C(t-50) + \left( \frac{1}{12.5} \right) V_m(t)$$

t	$V_k$	$V_m$	$I_m$	$I_k$	$I_C$
$\mu\text{s}$	kV	kV	kA	kA	kA
0	0.0	0	0	0	0
50	0.0025	0	$1.66 \times 10^{-5}$	0	0
100	0.0050	0	$3.33 \times 10^{-5}$	0	0
150	0.0075	0	$5.0 \times 10^{-5}$	0	0
200	0.0100	0	$6.67 \times 10^{-5}$	0	0
250	0.0125	$3.32 \times 10^{-4}$	$8.34 \times 10^{-5}$	$1.43 \times 10^{-5}$	$2.66 \times 10^{-5}$
300	0.0150	$1.20 \times 10^{-3}$	$10.0 \times 10^{-5}$	$2.53 \times 10^{-5}$	$6.94 \times 10^{-5}$

13.22

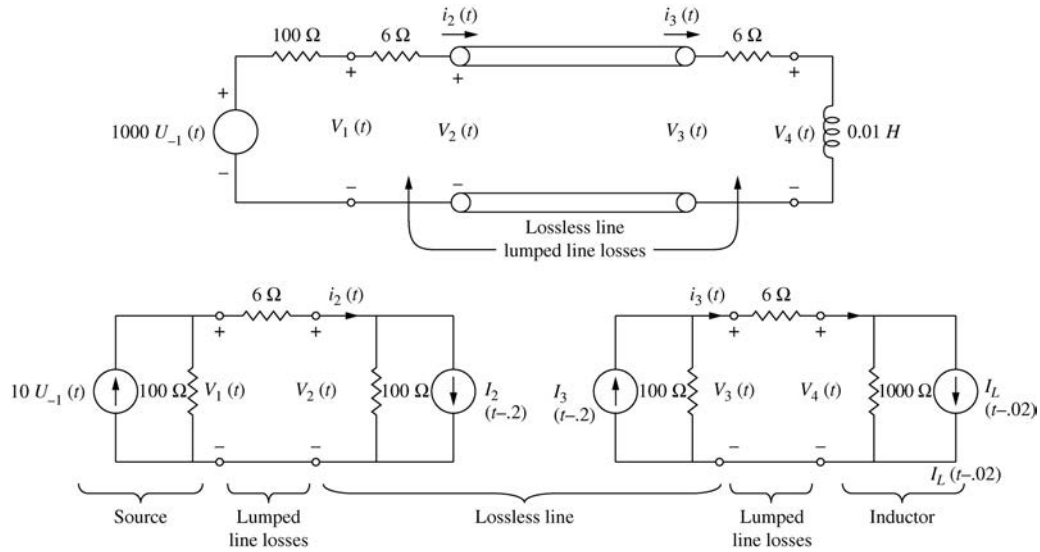

Nodal Equations:

$$\begin{bmatrix} V_1(t) \\ V_2(t) \end{bmatrix} = \begin{bmatrix} 0.1767 & -0.1667 \\ -0.1667 & 0.1767 \end{bmatrix}^{-1} \begin{bmatrix} 10 \\ -I_2(t-0.2) \end{bmatrix} \quad (a)$$

$$\begin{bmatrix} V_3(t) \\ V_4(t) \end{bmatrix} = \begin{bmatrix} 0.1767 & -0.1667 \\ -0.1667 & 0.1677 \end{bmatrix}^{-1} \begin{bmatrix} I_3(t-0.2) \\ -I_L(t-0.02) \end{bmatrix} \quad (c)$$

Dependent current sources:

$$\text{Eq (13.4.10)} \quad I_2(t) = I_3(t-0.2) - \left(\frac{2}{100}\right)V_3(t) \quad (e)$$

$$\text{Eq (13.4.9)} \quad I_3(t) = I_2(t-0.2) + \left(\frac{2}{100}\right)V_2(t) \quad (f)$$

$$\text{Eq (13.4.14)} \quad I_L(t) = I_L(t-0.02) + \frac{V_4(t)}{500} \quad (g)$$

Equations (a) – (g) can be solved iteratively for  $t = 0, \Delta t, 2\Delta t \dots$  where  $\Delta t = 0.02 \text{ ms}$ .  $I_2(\ )$  and  $I_3(\ )$  on the right hand side of Eqs (a) – (g) are zero for the first 10 iterations.

- 13.23 (a)** The maximum 60-Hz voltage operating voltage under normal operating conditions is  $1.08(115/\sqrt{3}) = 71.7 \text{ kV}$ . From Table 13.2, select a station-class surge arrester with 84-kV MCOV. This is the station-class arrester with the lowest MCOV that exceeds 71.7kV, providing the greatest protective margin and economy. (Note: where additional economy is required, an intermediate-class surge arrester with an 84-kV MCOV may be selected.)

- (b) From Table 13.2 for the selected station-class arrester, the maximum discharge voltage (also called Front-of-Wave Protective Level) for a 10-kA impulse current cresting in  $0.5 \mu\text{s}$  ranges from 2.19 to 2.39 in per unit of MCOV, or 184 to 201 kV, depending on arrester manufacturer. Therefore, the protective margin varies from  $(450 - 201) = 249\text{kV}$  to  $(450 - 184) = 266\text{kV}$ .

Note. From Table 3 of the Case Study for Chapter 13, select a VariSTAR Type AZE station-class surge arrester, manufactured by Cooper Power Systems, rated at 108kV with an 84-kV MCOV. From Table 3 for the selected arrester, the Front-of-Wave Protective Level is 313kV, and the protective margin is therefore  $(450 - 313) = 137\text{kV}$  or  $137/84 = 1.63$  per unit of MCOV.

- 13.24** The maximum 60-Hz line-to-neutral voltage under normal operating conditions on the HV side of the transformer is  $1.1(345/\sqrt{3}) = 219.1\text{kV}$ . From Table 3 of the Case Study for Chapter 13, select a VariSTAR Type AZE station-class surge arrester, manufactured by Cooper Power Systems, with a 276-kV rating and a 220-kV MCOV. This is the type AZE station-class arrester with the lowest MCOV that exceeds 219.1 kV, providing the greatest protective margin and economy. For this arrester, the maximum discharge voltage (also called Front-of-Wave Protective Level) for a 10-kA impulse current cresting in  $0.5 \mu\text{s}$  is 720kV. The protective margin is  $(1300 - 720) = 580\text{kV} = 580/220 = 2.64$  per unit of MCOV.



# Chapter 14

## Power Distribution

- 14.1** See Figure 14.2. Yes, laterals on primary radial systems are typically protected from short circuits. Fuses are typically used for short-circuit protection on the laterals.
- 14.2** The three-phase, four-wire multigrounded primary system is the most widely used primary distribution configuration. The fourth wire in these Y-connected systems is used as a neutral for the primaries, or as a common neutral when both primaries and secondaries are present. Usually the windings of distribution substation transformers are Y-connected on the primary distribution side, with the neutral point grounded and connected to the common neutral wire. The neutral is also grounded at frequent intervals along the primary, at distribution transformers, and at customers' service entrances. Sometimes distribution substation transformers are grounded through an impedance (approximately one ohm) to limit short circuit currents and improve coordination of protective devices.
- 14.3** See Table 14.1 for a list of typical primary distribution voltages in the United States [1–9]. The most common primary distribution voltage is 15-kV Class, which includes 12.47, 13.2, and 13.8 kV.
- 14.4** Reclosers are typically used on (a) overhead primary radial systems (see Figure 14.2) and on (c) overhead primary loop systems (see Figure 14.7). Studies have shown that the large majority of faults on overhead primaries are temporary, caused by lightning flashover of line insulators, momentary contact of two conductors, momentary bird or animal contact, or momentary tree limb contact. As such, reclosers are used on overhead primary systems to reduce the duration of interruptions for these temporary faults. Reclosers are not used on primary systems that are primarily underground, because faults on underground systems are usually permanent.
- 14.5** See Table 14.2. Typical secondary distribution voltages in the United States are 120/240 V, single-phase, three-wire for Residential applications; 208Y/120V, three-phase, four-wire for Residential/Commercial applications; and 480Y/277V, three-phase, four-wire for Commercial/Industrial/High-Rise applications.
- 14.6** Secondary Network Advantages  
Secondary networks provide a high degree of service reliability and operating flexibility. They can be used to supply high-density load areas in downtown sections of cities. In secondary network systems, a forced or scheduled outage of a primary feeder does not result in customer outages. Because the secondary mains provide parallel paths to customer loads, secondary cable failures usually do not result in customer outages. Also, each secondary network is designed to share the load equally among transformers and to handle large motor starting and other abrupt load changes without severe voltage drops.

### Secondary Network Disadvantage

Secondary networks are expensive. They are typically used in high-density load areas where revenues justify grid costs.

- 14.7** As stated in Section 14.3, more than 260 cities in the United States have secondary networks. If one Googles “secondary electric power distribution networks United States,” one of the web sites that appears in the Google list is:

#### Interconnection of Distributed Energy Resources in Secondary...

File Format: PDF/Adobe Acrobat. **Electric Power** Research Institute and EPRI are registered service marks of the Electric ... **SECONDARY DISTRIBUTION NETWORK OVERVIEW**. Power System Design and Operation ... Printed on recycled paper in the **United States** of America ... mydocs.epri.com/docs/public/00000000001012922.pdf

The following is stated on Page 2-5 of the above-referenced publication:

“Major cities, such as New York, Seattle, and Chicago have extensive distribution network systems. However, even smaller cities, such as Albany or Syracuse, New York, or Knoxville, Tennessee, have small spot or grid networks in downtown areas.”

- 14.8** (a) At the OA rating of 40 MVA,

$$I_{OA,L} = \frac{40}{(13.8 \times \sqrt{3})} = 1.673 \text{ kA per phase}$$

Similarly,

$$I_{FA,L} = \frac{50}{(13.8 \times \sqrt{3})} = 2.092 \text{ kA per phase}$$

$$I_{FOA,L} = \frac{65}{(13.8 \times \sqrt{3})} = 2.719 \text{ kA per phase}$$

- (b) The transformer impedance is 8% or 0.08 per unit based on the OA rating of 40 MVA. Using (3.3.11), the transformer per unit impedance on a 100 MVA system base is:

$$Z_{\text{transformerPUSystem Base}} = 0.08 \left( \frac{100}{40} \right) = 0.20 \text{ per unit}$$

- (c) For a three-phase bolted fault, using the transformer OA ratings as the base quantities,

$$\begin{aligned} I_{sc3\phi} &= \frac{V_F}{Z_{\text{transformerPU}}} = \frac{1.0}{(0.08)} = 12.5 \text{ per unit} = (12.5)(1.673) \\ &= 20.91 \text{ kA/phase} \end{aligned}$$

Note that in (c) above, the OA rating is used to calculate the short-circuit current, because the transformer manufacturer gives the per unit transformer impedance using the OA rating as the base quantity.

- 14.9** (a) During normal operations, all four transformers are in service. Using a 5% reduction to account for unequal transformer loadings, the summer normal substation rating is  $1.20 \times (30 + 33.3 + 33.3 + 33.3) \times 0.95 = 148$  MVA. With all four transformers in service, the substation can operate as high as 148 MVA without exceeding the summer normal rating of 120% of each transformer rating.
- (b) The summer allowable substation rating, based on the single-contingency loss of one of the 33.3 MVA transformers, would be  $1.5 \times (30 + 33.3 + 33.3) \times 0.95 = 137$  MVA. Each of the three transformers that remain in service is each allowed to operate at 150% of its nameplate rating for two hours (reduced by 5% for unequal transformer loadings), which gives time to perform switching operations to reduce the transformer loading to its 30-day summer emergency rating. However, from the solution to (c), the 30-day summer emergency rating of the substation is 119.3 MVA. Since it is assumed that a maximum reduction of 10% in the total substation load can be achieved through switching operations, the summer allowable substation rating is limited to  $119.3/0.9 = 132.6$  MVA. Note that, even though the normal summer substation rating is 148 MVA, it is only allowed to operate up to 132.6 MVA, so that in case one transformer has a permanent outage: (1) the remaining in-service transformers do not exceed their two-hour emergency ratings; and (2) switching can be performed to reduce the total substation load to its 30-day emergency rating.
- (c) Based on the permanent loss of one 33.3-MVA transformer, the 30-day summer emergency rating of the substation is  $1.3 \times (30 + 33.3 + 33.3) \times 0.95 = 119.3$  MVA. When one transformer has a permanent failure, each of the other three transformers can operate at 130% of their rating for 30 days (reduced by 5% for unequal transformer loadings), which gives time to replace the failed transformer with a spare that is in stock.

**14.10** Based on a maximum continuous current of 2.0 kA per phase, the maximum power through each circuit breaker at 12.5 kV is  $12.5 \times 2.0 \times \sqrt{3} = 43.3$  MVA. The summer allowable substation rating under the single-contingency loss of one transformer, based on not exceeding the maximum continuous current of the circuit breakers, is  $43.3 \times 3 \times 0.95 = 123.4$  MVA. Comparing this result with the summer allowable substation rating of 132.6 MVA determined in Problem 14.9(b), we conclude that the circuit breakers limit the summer allowable substation rating to 123.4 MVA.

- 14.11** (a) The power factor angle of the load is  $\theta_L = \cos^{-1}(0.85) = 31.79^\circ$ . Using Figure 2.5, the load reactive power is:

$$\begin{aligned} Q_L &= S_L \sin(\theta_L) = 10 \times \sin(31.79^\circ) \\ &= 5.268 \text{ Mvar absorbed} \end{aligned}$$

Also, the real power absorbed by the load is  $S_L \times \text{p.f.} = 10 \times 0.85 = 8.5$  MW

Similarly, the power factor angle of the source is  $\theta_s = \cos^{-1}(0.90) = 25.84^\circ$ . The real power delivered by the source to the load is 8.5 MW, which is unchanged by the shunt capacitors. Using Figure 2.5, the source reactive power is:

$$\begin{aligned} Q_s &= S_s \sin(\theta_s) = \left[ \frac{P_s}{\text{p.f.}} \right] \sin(\theta_s) = \left[ \frac{8.5}{0.90} \right] \sin(25.84^\circ) \\ &= 4.117 \text{ Mvar delivered} \end{aligned}$$



The reactive power delivered by the shunt capacitors is the load reactive power minus the source reactive power:

$$Q_c = Q_L - Q_s = 5.268 - 4.117 = 1.151 \text{ Mvar}$$

- (b) The power factor angle of the load is  $\theta_L = \cos^{-1}(0.90) = 25.84^\circ$ . Using Figure 2.5, the load reactive power is:

$$\begin{aligned} Q_L &= S_L \sin(\theta_L) = 10 \times \sin(25.84^\circ) \\ &= 4.359 \text{ Mvar absorbed} \end{aligned}$$

Also, the real power absorbed by the load is  $S_L \times \text{p.f.} = 10 \times 0.90 = 9.0 \text{ MW}$

Similarly, the power factor angle of the source is  $\theta_s = \cos^{-1}(0.95) = 18.19^\circ$ . The real power delivered by the source to the load is 9.0 MW, which is unchanged by the shunt capacitors. Using Figure 2.5, the source reactive power is:

$$\begin{aligned} Q_s &= S_s \sin(\theta_s) = \left[ \frac{P_s}{\text{p.f.}} \right] \times \sin(\theta_s) = \left[ \frac{9.0}{0.95} \right] \sin(18.19^\circ) \\ &= 2.958 \text{ Mvar delivered} \end{aligned}$$

The reactive power delivered by the shunt capacitors is the load reactive power minus the source reactive power:

$$Q_c = Q_L - Q_s = 4.359 - 2.958 = 1.401 \text{ Mvar}$$

- (c) Comparing the results of (a) which requires 1.151 Mvar to increase the power factor from 0.85 to 0.90 lagging; and (b) which requires 1.401 Mvar (22% higher than 1.151 Mvar) to increase the power factor from 0.90 to 0.95 lagging; it is concluded that improving the high power-factor load requires more reactive power.

- 14.12** (a) Without the capacitor bank, the total impedance seen by the source is:

$$Z_{\text{TOTAL}} = R_{\text{LINE}} + jX_{\text{LINE}} + \frac{1}{\frac{1}{R_{\text{LOAD}}} + \frac{1}{jX_{\text{LOAD}}}}$$

$$Z_{\text{TOTAL}} = 3 + j6 + \frac{1}{\frac{1}{40} + \frac{1}{j60}}$$

$$Z_{\text{TOTAL}} = 3 + j6 + \frac{1}{\frac{0.03}{-33.69^\circ}} = 3 + j6 + \frac{33.333}{33.69^\circ}$$

$$Z_{\text{TOTAL}} = 3 + j6 + 27.74 + j18.49 = 30.74 + j24.49 = \frac{39.30}{38.54^\circ} \Omega/\text{phase}$$

- (a1) The line current is:

$$I_{\text{LINE}} = \frac{V_{\text{SLN}}}{Z_{\text{TOTAL}}} = \frac{1.05 \left( \frac{13.8}{\sqrt{3}} \right) / 0^\circ}{\left( \frac{39.30}{38.54^\circ} \right)} = \frac{0.2129}{-38.54^\circ} \text{ kA/phase}$$

(a2) The voltage drop across the line is:

$$V_{\text{DROP}} = \frac{Z_{\text{LINE}}}{I_{\text{LINE}}} = (3 + j6) \left( \frac{0.2129}{-38.54^\circ} \right)$$

$$= \left( \frac{6.708}{63.43^\circ} \right) \left( \frac{0.2129}{-38.54^\circ} \right)$$

$$\frac{1.428}{24.89^\circ} \text{ kV}$$

$$|V_{\text{DROP}}| = 1.428 \text{ kV}$$

(a3) The load voltage is:

$$V_{\text{LOAD}} = V_{\text{SLN}} - Z_{\text{LINE}} I_{\text{LINE}} = 1.05 \left( \frac{13.8}{\sqrt{3}} \right) - \frac{1.428}{24.89^\circ}$$

$$= 8.366 - (1.295 + j0.60010) = 7.071 - j0.6010$$

$$= \frac{7.096}{-4.86^\circ} \text{ kV}_{\text{LN}}$$

$$|V_{\text{LOAD}}| = 7.096\sqrt{3} = 12.29 \text{ kV}_{\text{LL}}$$

(a4) The real and reactive power delivered to the three-phase load is:

$$P_{\text{LOAD}3\phi} = \frac{3(V_{\text{LOADLN}})^2}{R_{\text{LOAD}}} = \frac{3(7.096)^2}{40} = 3.776 \text{ MW}$$

$$Q_{\text{LOAD}3\phi} = \frac{3(V_{\text{LOADLN}})^2}{X_{\text{LOAD}}} = \frac{3(7.096)^2}{60} = 2.518 \text{ Mvar}$$

(a5) The load power factor is:

$$\text{p.f.} = \cos \left[ \tan^{-1} \left( \frac{Q}{P} \right) \right] = \cos \left[ \tan^{-1} \left( \frac{2.518}{3.776} \right) \right] = 0.83 \text{ lagging}$$

(a6) The real and reactive line losses are:

$$P_{\text{LINELOSS}3\phi} = 3I_{\text{LINE}}^2 R_{\text{LINE}} = 3(0.2129)^2(3) = 0.408 \text{ MW}$$

$$Q_{\text{LINELOSS}3\phi} = 3I_{\text{LINE}}^2 X_{\text{LINE}} = 3(0.2129)^2(6) = 0.816 \text{ Mvar}$$

(a7) The real power, reactive power, and apparent power delivered by the distribution substation are:

$$P_{\text{SOURCE}3\phi} = P_{\text{LOAD}3\phi} + P_{\text{LINELOSS}3\phi} = 3.776 + 0.408 = 4.184 \text{ MW}$$

$$Q_{\text{SOURCE}3\phi} = Q_{\text{LOAD}3\phi} + Q_{\text{LINELOSS}3\phi} = 2.518 + 0.816 = 3.334 \text{ Mvar}$$

$$S_{\text{SOURCE}3\phi} = \sqrt{(4.184^2 + 3.334^2)} = 5.350 \text{ MVA}$$

(b) With the capacitor bank in service, the total impedance seen by the source is:

$$Z_{\text{TOTAL}} = R_{\text{LINE}} + jX_{\text{LINE}} + \frac{1}{\frac{1}{R_{\text{LOAD}}} + \frac{1}{jX_{\text{LOAD}}} - \frac{1}{jX_{\text{C}}}}$$

$$Z_{\text{TOTAL}} = 3 + j6 + \frac{1}{\frac{1}{40} + \frac{1}{j60} - \frac{1}{j60}}$$

$$Z_{\text{TOTAL}} = 3 + j6 + \frac{1}{0.025} = 43 + j6 = \frac{43.42}{7.94^\circ} \Omega/\text{phase}$$

(b1) The line current is:

$$I_{\text{LINE}} = \frac{V_{\text{SLN}}}{Z_{\text{TOTAL}}} = \frac{1.05 \left( \frac{13.8}{\sqrt{3}} \right) / 0^\circ}{\frac{43.42}{7.94^\circ}} = \frac{0.1927}{-7.94^\circ} \text{ kA/phase}$$

(b2) The voltage drop across the line is:

$$V_{\text{DROP}} = Z_{\text{LINE}} I_{\text{LINE}} = \left( \frac{6.708}{63.43^\circ} \right) \left( \frac{0.1927}{-7.94^\circ} \right) = \frac{1.293}{55.49^\circ} \text{ kV}$$

$$|V_{\text{DROP}}| = 1.293 \text{ kV}$$

(b3) The load voltage is:

$$V_{\text{LOAD}} = V_{\text{SLN}} - Z_{\text{LINE}} I_{\text{LINE}} = 1.05 \left( \frac{13.8}{\sqrt{3}} \right) / 0^\circ - \frac{1.293}{55.49^\circ}$$

$$= 8.366 - (0.7325 + j1.065) = 7.633 - j1.065$$

$$= \frac{7.707}{-7.94^\circ} \text{ kV}_{\text{LN}}$$

$$|V_{\text{LOAD}}| = 7.707 \sqrt{3} = 13.35 \text{ kV}_{\text{LL}}$$

(b4) The real and reactive power delivered to the three-phase load is:

$$P_{\text{LOAD}3\phi} = \frac{3(V_{\text{LOADLN}})^2}{R_{\text{LOAD}}} = \frac{3(7.707)^2}{40} = 4.455 \text{ MW}$$

$$Q_{\text{LOAD}3\phi} = \frac{3(V_{\text{LOADLN}})^2}{X_{\text{LOAD}}} = \frac{3(7.707)^2}{60} = 2.970 \text{ Mvar}$$

(b5) The load power factor is:

$$\text{p.f.} = \cos \left[ \tan^{-1} \left( \frac{Q}{P} \right) \right] = \cos \left[ \tan^{-1} \left( \frac{2.970}{4.455} \right) \right] = 0.83 \text{ lagging}$$

(b6) The real and reactive line losses are:

$$P_{\text{LINELOSS}3\phi} = 3 I_{\text{LINE}}^2 R_{\text{LINE}} = 3(0.1927)^2 (3) = 0.3342 \text{ MW}$$

$$Q_{\text{LINELOSS}3\phi} = 3 I_{\text{LINE}}^2 X_{\text{LINE}} = 3(0.1927)^2 (6) = 0.6684 \text{ Mvar}$$

(b7) The reactive power delivered by the shunt capacitor bank is:

$$Q_{\text{C}} = \frac{3(V_{\text{LOADLN}})^2}{X_{\text{C}}} = \frac{3(7.707)^2}{60} = 2.970 \text{ Mvar}$$

(b8) The real power, reactive power, and apparent power delivered by the distribution substation are:

$$P_{\text{SOURCE}3\phi} = P_{\text{LOAD}3\phi} + P_{\text{LINELOSS}3\phi} = 4.455 + 0.3342 = 4.789 \text{ MW}$$

$$Q_{\text{SOURCE}3\phi} = Q_{\text{LOAD}3\phi} + Q_{\text{LINELOSS}3\phi} - QC = 2.970 + 0.6684 - 2.97 \\ = 0.6684 \text{ Mvar}$$

$$S_{\text{SOURCE}3\phi} = \sqrt{(4.7892 + 0.66842)} = 4.835 \text{ MVA}$$

(c) Comparing the results of (a) and (b), with the shunt capacitor bank in service, the real power delivered to the load increases by 18% (from 3.776 to 4.445 MW) while at the same time:

- The line current decreases from 0.2129 to 0.1927 kA/phase
- The real line losses decrease from 0.408 to 0.334 MW
- The reactive line losses decrease from 0.816 to 0.668 Mvar
- The voltage drop across the line decreases from 1.428 to 1.293 kV
- The reactive power delivered by the source decreases from 3.334 to 0.6684 Mvar
- The load voltage increases from 12.29 to 13.35 kV<sub>LL</sub>

The above benefits are achieved by having the shunt capacitor bank (instead of the distribution substation) deliver reactive power to the load.

**14.13** (a) Using all the outage data from the Table in (14.7.1) – (14.7.4):

$$\text{SAIFI} = \frac{342 + 950 + 125 + 15 + 2200 + 4000 + 370}{4500}$$

$$= 1.7782 \text{ interruptions/year}$$

$$(14.4 \times 342) + (151.2 \times 950) + (89.8 \times 125)$$

$$\text{SAIDI} = \frac{+ (654.6 \times 15) + (32.7 \times 2200) + (10053 \times 4000) + (40 \times 370)}{4500}$$

$$\text{SAIDI} = 8992.966 \text{ minutes/year} = 149.88 \text{ hours/year}$$

$$\text{CAIDI} = \frac{\text{SAIDI}}{\text{SAIFI}} = \frac{8992.966}{1.7782} = 5057.34 \text{ minutes/year} = 84.289 \text{ hours/year}$$

$$8760 \times 4500 - [(14.4 \times 342) + (151.2 \times 950)$$

$$+ (89.8 \times 125) + (654.6 \times 15) + (32.7 \times 2200)$$

$$\text{ASAI} = \frac{+ (10053 \times 4000) + (40 \times 370)]/60}{8760 \times 4500}$$

$$\text{ASAI} = 0.98289 = 98.289\%$$

(b) Omitting the major event on 11/04 2010 and using the remaining outage data from the table in (14.7.1) – (14.7.4):

$$\text{SAIFI} = \frac{342 + 950 + 125 + 15 + 2200 + 370}{4500} = 0.889 \text{ interruptions/year}$$

$$(14.4 \times 342) + (151.2 \times 950) + (89.8 \times 125)$$

$$\text{SAIDI} = \frac{+ (654.6 \times 15) + (32.7 \times 2200) + (40 \times 370)}{4500}$$

$$\text{SAIDI} = 56.966 \text{ minutes/year}$$

$$CAIDI = \frac{SAIDI}{SAIFI} = \frac{56.966}{0.889} = 64.079 \text{ minutes/year}$$

$$8760 \times 4500 - [(14.4 \times 342) + (151.2 \times 950)$$

$$ASAI = \frac{+ (89.8 \times 125) + (654.6 \times 15) + (32.7 \times 2200) + (40 \times 370)]/60}{8760 \times 4500}$$

$$ASAI = 0.99989 = 99.989\%$$

Comparing the results of (a) and (b), the CAIDI is 84.289 **hours/year** including the major event versus 64.079 **minutes/year** or 1.068 **hours/year** excluding the major event.

**14.14** Using the outage data from the two tables, and omitting the major event:

$$200 + 600 + 25 + 90 + 700 + 1500 + 100$$

$$SAIFI = \frac{+ 342 + 950 + 125 + 15 + 2200 + 370}{2000 + 4500}$$

$$SAIFI = 1.110 \text{ interruptions/year}$$

$$SAIDI = [(8.17 \times 200) + (71.3 \times 600) + (30.3 \times 25) + (267.2 \times 90)$$

$$+ (120 \times 700) + (10 \times 1500) + (40 \times 100) + (14.4 \times 342)$$

$$+ (151.2 \times 950) + (89.8 \times 125) + (654.6 \times 15)$$

$$+ (32.7 \times 2200) + (40 \times 370)]/[2000 + 4500]$$

$$SAIDI = 428,568.3/6500 = 65.934 \text{ minutes/year}$$

$$CAIDI = \frac{SAIDI}{SAIFI} = \frac{65.934}{1.110} = 59.400 \text{ minutes/year}$$

$$ASAI = [8760 \times 6500 - 428,568.3/60]/[8760 \times 6500] = 0.99987 = 99.987\%$$

**14.15** The optimal solution space is rather flat around a value of 0.066 MW for total system losses. The below system solution represents an optimal (or near optimal) solution.

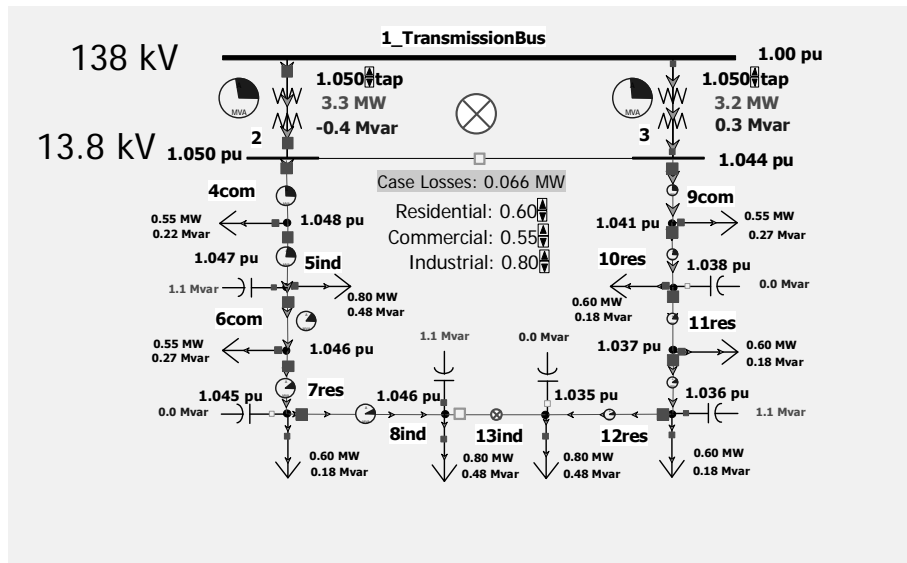

**14.16** Initial losses are 0.082 MW. When the bus tie breaker is closed the losses increase to 0.124 MW. This increase is due to circulating reactive power between the two transformers. The losses can be reduced by balancing the taps; opening some of the capacitors can also help reduce losses. The below system solution has reduced the losses to 0.053 MW. Again the solution space is flat so there are a number of near optimal solutions that would be acceptable.

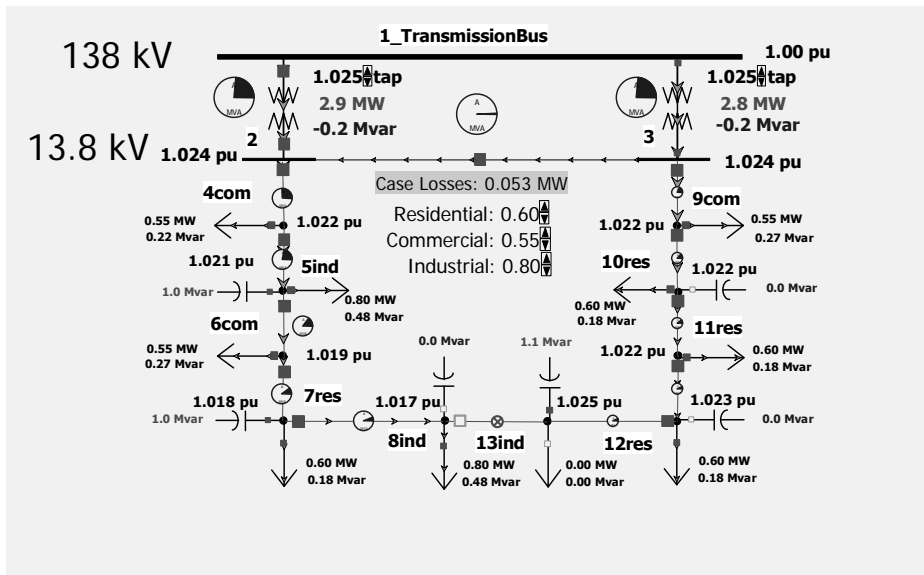

**14.17** Because of the load voltage dependence, the total load plus losses are minimized by reducing the voltages to close to the minimum constraint of 0.97 per unit. Again, the solution space is quite flat, with an optimal (or near optimal) solution shown below with total load + losses of 9.882 MW (versus a starting value of 10.644 MW).

