

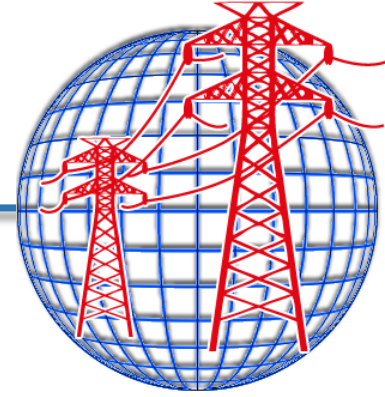

**BIRZEIT UNIVERSITY
FACULTY OF ENGINEERING
AND TECHNOLOGY**



PROTECTION AND AUTOMATION IN ELECTRICAL POWER SYSTEMS

INSTRUMENT TRANSFORMERS

By





Dr. Jaser Sa'ed



Department of Electrical and Computer Engineering



INTRODUCTION

-  **Detecting faults and other abnormal power system operating conditions requires that we monitor power system variables – that is, current, voltage, power, and impedance.**
-  **If we measure current and voltage, we can process these signals to obtain information regarding power and impedance.**
-  **Since power system voltages and currents are in kilovolt and kiloamp range; it is necessary to use signals that are proportional to system values for safety, economy, and convenience of measurement.**
-  **There are two basic types of instrument transformers: voltage transformers (VTs), formerly called potential transformers (PTs), and current transformers (CTs).**

Advantages

INTRODUCTION



Current transformers and voltage transformers have the following advantages :

- ❑ **Safety**: Instrument transformers provide electrical isolation from the power system so that personnel working with relays will work in a safer environment.
- ❑ **Economy**: Lower-level relay inputs enable relays to be smaller, simpler, and less expensive.
- ❑ **Accuracy**: Instrument transformers accurately reproduce power system currents and voltages over wide operating ranges.

INTRODUCTION



VT and CT schematic:

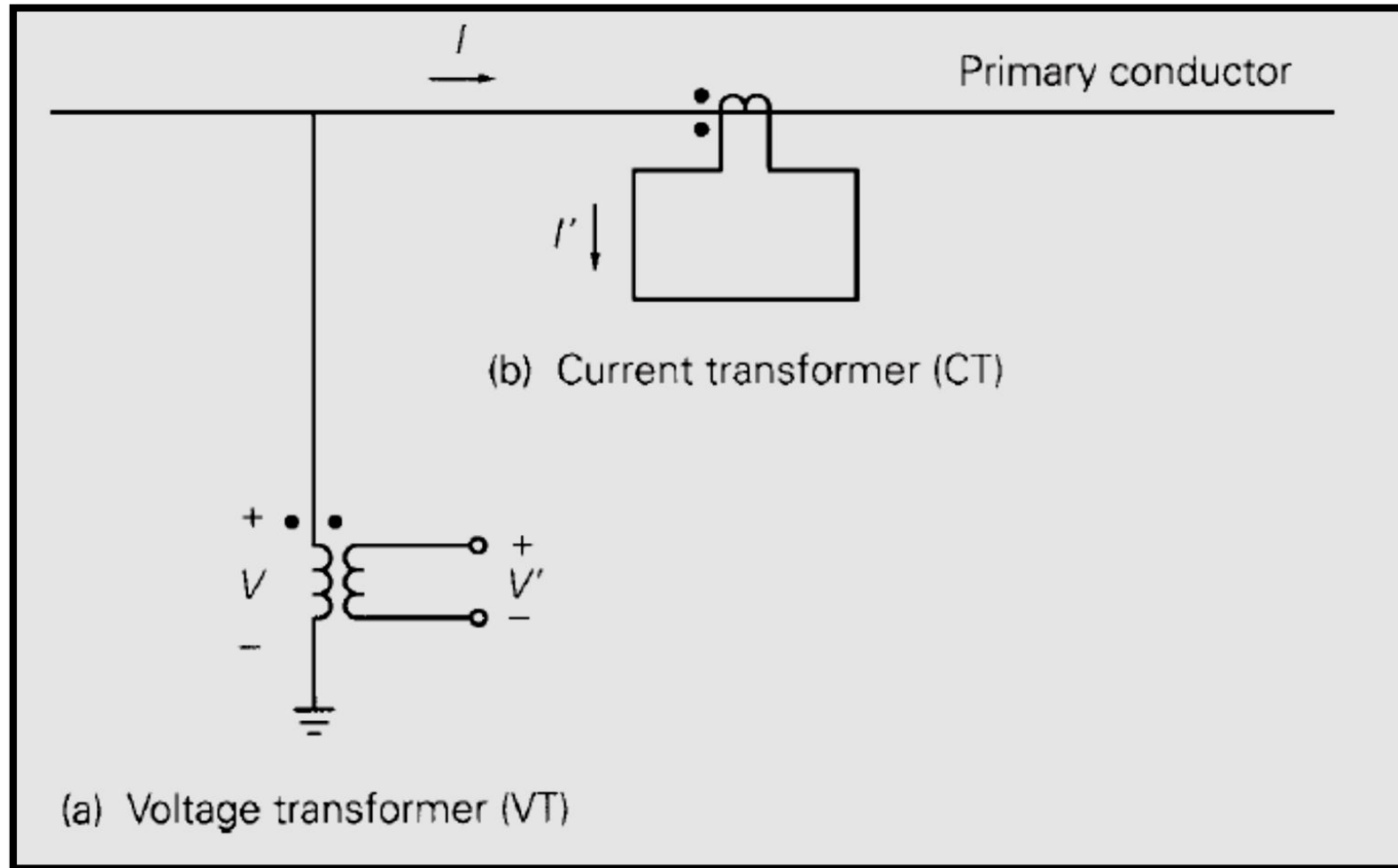

CURRENT TRANSFORMERS



The current transformer has two jobs to do. Firstly, it steps down the current to such levels that it can be easily handled by the relay. Secondly, it isolates the relay circuit from the high voltage of the power system.



It may be pointed out here, that current transformers are used for metering purposes as well. However, there is a very important difference between a metering CT and a protection CT. A metering CT is so designed that in case of faults, it will saturate and thus save the instrument connected to its secondary from damage due to excessive current. On the other hand, a protective CT is designed to faithfully reproduce the largest fault current.

CURRENT TRANSFORMERS



Protective CT vs. Measurement CT

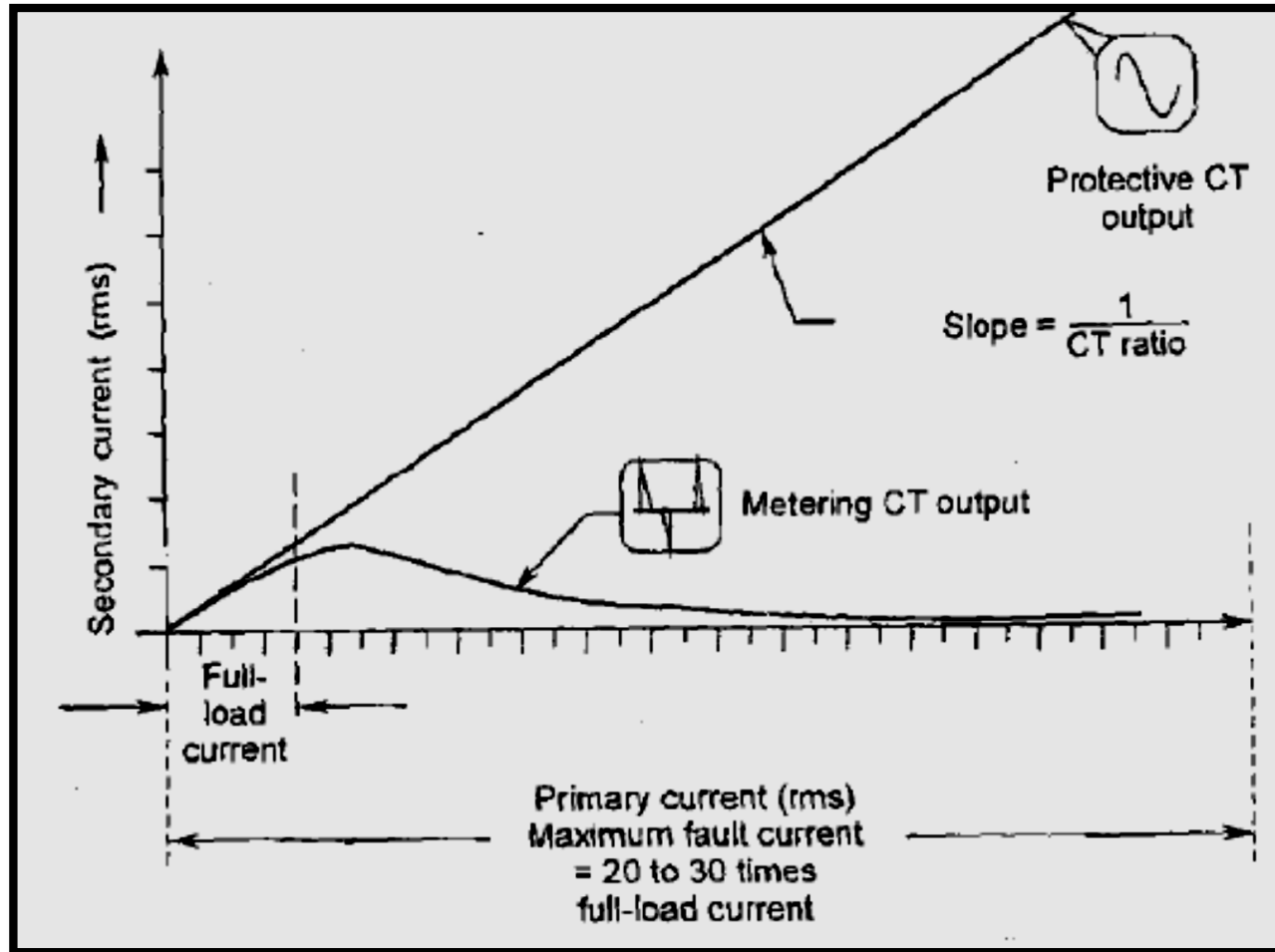

CURRENT TRANSFORMERS



The primary winding of a current transformer usually consists of a single turn, obtained by running the power system's primary conductor through the CT core.



The normal current rating of CT secondaries is standardized at 5 A in the United States, whereas 1 A is standard in Europe and some other regions

STANDARD CT RATIOS

Current Ratios						
50:5	100:5	150:5	200:5	250:5	300:5	400:5
450:5	500:5	600:5	800:5	900:5	1000:5	1200:5
1500:5	1600:5	2000:5	2400:5	2500:5	3000:5	3200:5
4000:5	5000:5	6000:5				

Current Ratio \longrightarrow N2:N1

Turns Ratio (n) \longrightarrow N1:N2

Turns Ratio \longrightarrow 1:10, 1:20, 1:30, 1:40,

CT EQUIVALENT CIRCUIT

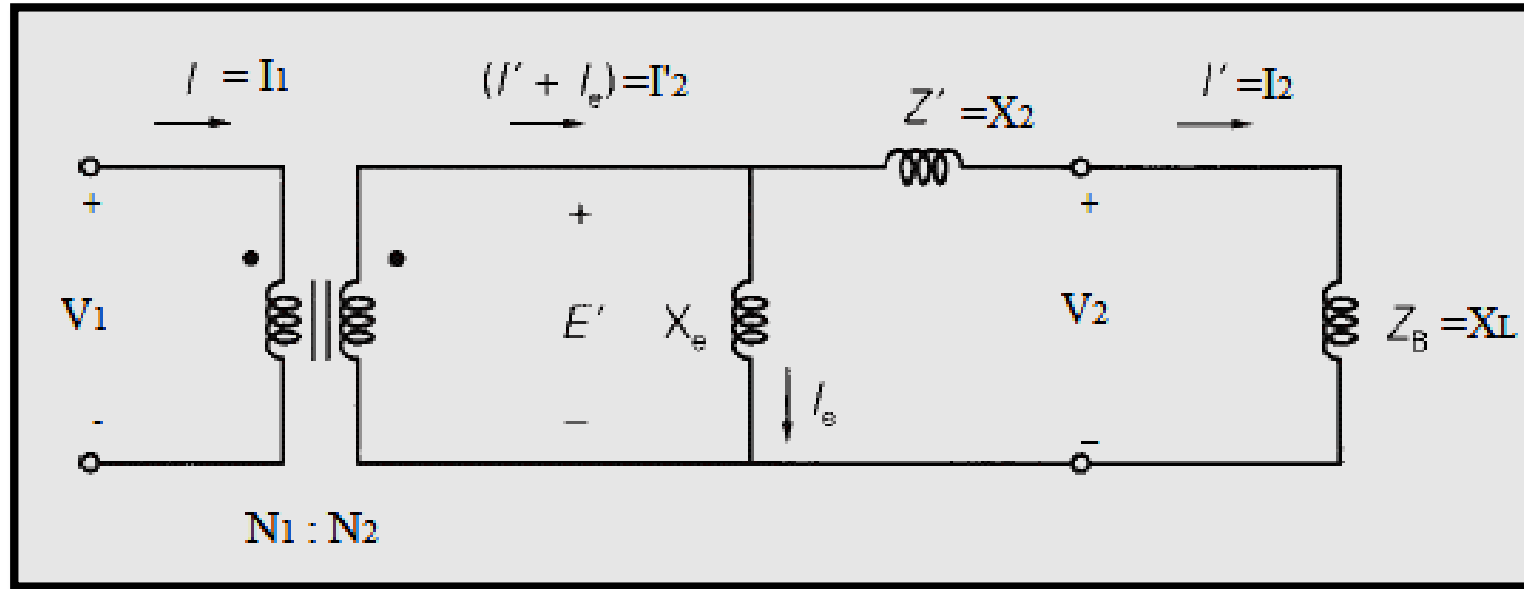

Where:

Z' = CT secondary leakage impedance

X_e = CT excitation reactance (Saturable reactance)

Z_B = Impedance of terminating device (relay)

$$I'_2 = \frac{N_1}{N_2} I_1 \text{ and } E' = \frac{N_2}{N_1} V_1$$

$$E' = I_2 (X_2 + X_L)$$

$$E' = (X_2 + X_L) (I'_2 - I_e)$$

$$E' = (X_2 + X_L) \left(\frac{N_1}{N_2} I_1 - I_e \right)$$

CURRENT TRANSFORMERS - NOTES



In practice, the secondary current divides, with most flowing through the low-impedance sensing device and some flowing through the CT shunt excitation impedance. CT excitation impedance is kept high in order to minimize excitation current.



The total impedance Z_B of the terminating device is called the burden and is typically expressed in values of less than an ohm. The burden on a CT may also be expressed as volt-amperes at a specified current.



Associated with the CT equivalent circuit is an excitation curve that determines the relationship between the CT secondary voltage E' and excitation current I_e .

Excitation Curves Example

EXCITATION CURVES FOR A MULTI-RATIO CT

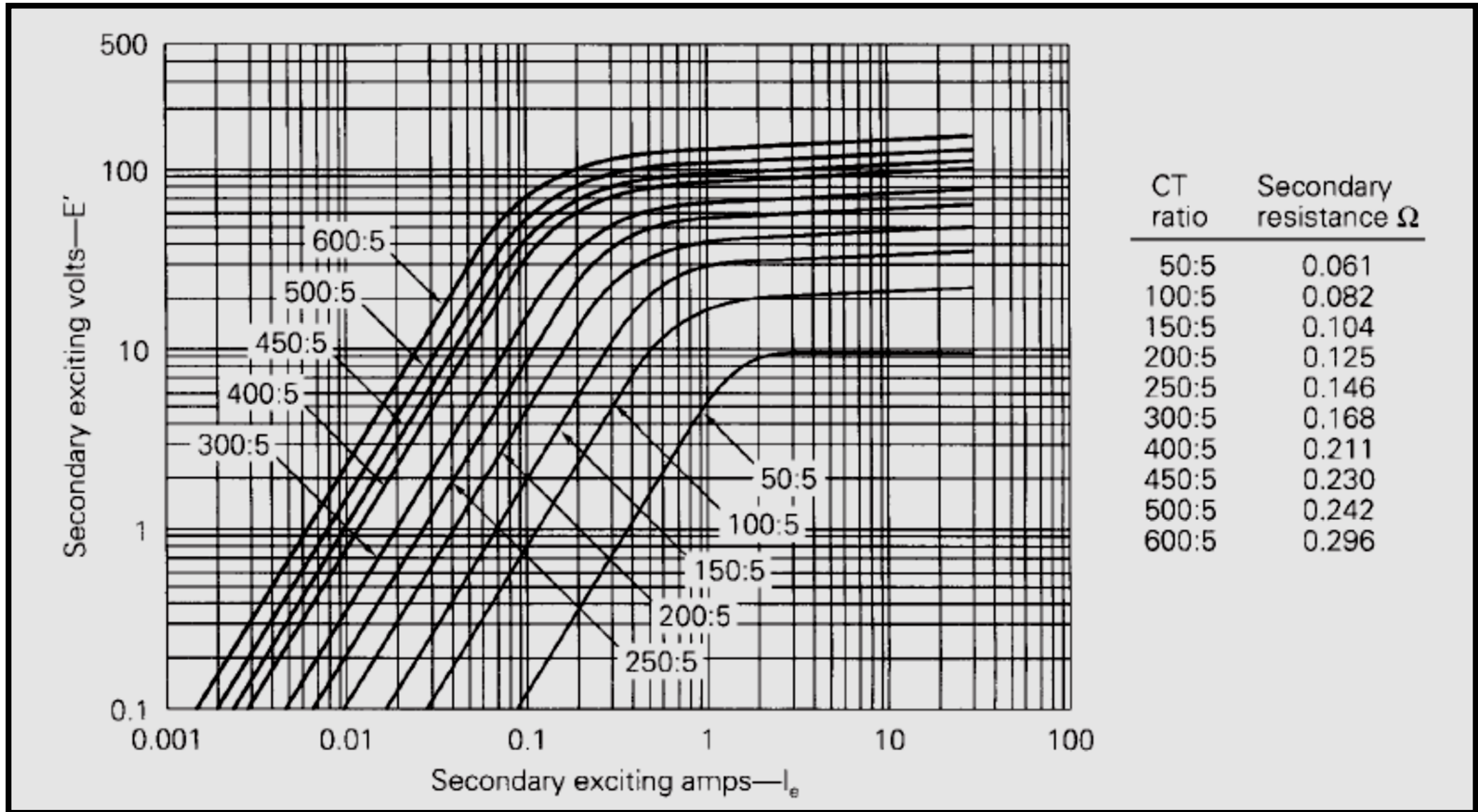

CURRENT TRANSFORMER PERFORMANCE



$$E' = (X_2 + X_L) \left(\frac{N_1}{N_2} I_1 - I_e \right)$$



A second constraint that must be satisfied is the magnetization curve.



To predict I_2 for a given I_1 with known termination (X_L), the above equation has two unknowns (E') and (I_e), and the second relation between (E') and (I_e) is the magnetization curve. If we plot the above equation on the same coordinates as the mag. curve, the intersection of the two plots will represent a solution for (E') and (I_e). Knowing (I_e) we can now solve for I_2 .

CURRENT TRANSFORMER PERFORMANCE



Current transformer performance is based on the ability to deliver a secondary output current I' that accurately reproduces the primary current I . Performance is determined by the highest current that can be reproduced without saturation to cause large errors.

- ✓ The following procedure can be used to determine CT performance
 - **STEP 1** : Assume a CT secondary output current I' .
 - **STEP 2** : Compute $E'=(Z'+Z_B)I'$.
 - **STEP 3** : Using E' , find I_e from the excitation curve.
 - **STEP 4** : Compute $I=n(I'+I_e)$.
 - **STEP 5** : Repeat Steps 1-4 for different values of I' , then plot I' vs. I .

CURRENT TRANSFORMER PERFORMANCE



“CT Error” is the deviation of I_2 from I'_2 as expressed as a percentage of I'_2

$$CT\ Error = \frac{I'_2 - I_2}{I'_2} = \frac{I_e}{I'_2} = \frac{I_e}{I_2 + I_e}$$

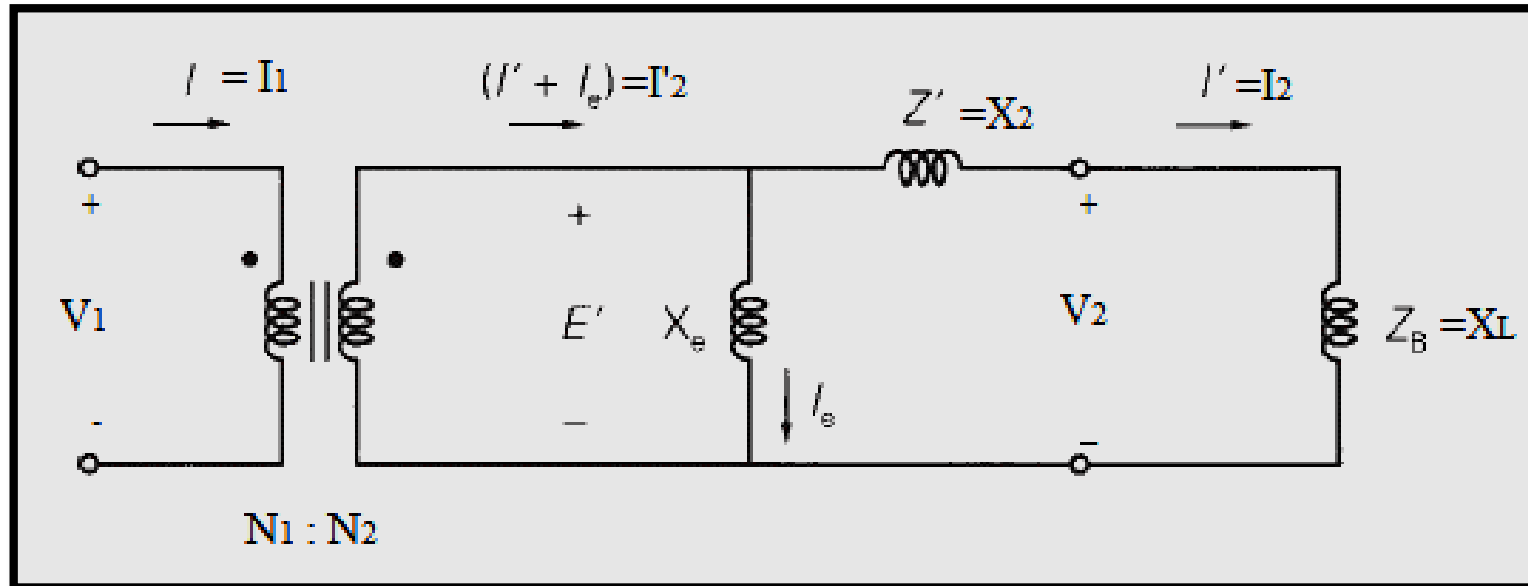

CURRENT TRANSFORMER PERFORMANCE- GLOVER BOOK

EXAMPLE

Evaluate the performance of the multiratio CT in Figure 10.8 with a 100:5 CT ratio, for the following secondary output currents and burdens: (a) $I' = 5$ A and $Z_B = 0.5 \Omega$; (b) $I' = 8$ A and $Z_B = 0.8 \Omega$; and (c) $I' = 15$ A and $Z_B = 1.5 \Omega$. Also, compute the CT error for each output current.

SOLUTION From Figure 10.8, the CT with a 100:5 CT ratio has a secondary resistance $Z' = 0.082 \Omega$. Completing the above steps:

a. **STEP 1** $I' = 5$ A

STEP 2 From Figure 10.7,

$$E' = (Z' + Z_B)I' = (0.082 + 0.5)(5) = 2.91 \text{ V}$$

STEP 3 From Figure 10.8, $I_c = 0.25$ A

STEP 4 From Figure 10.7, $I = (100/5)(5 + 0.25) = 105$ A

$$\text{CT error} = \frac{0.25}{5.25} \times 100 = 4.8\%$$

CURRENT TRANSFORMER PERFORMANCE- GLOVER BOOK

EXAMPLE

Evaluate the performance of the multiratio CT in Figure 10.8 with a 100:5 CT ratio, for the following secondary output currents and burdens: (a) $I' = 5$ A and $Z_B = 0.5 \Omega$; (b) $I' = 8$ A and $Z_B = 0.8 \Omega$; and (c) $I' = 15$ A and $Z_B = 1.5 \Omega$. Also, compute the CT error for each output current.

b. **STEP 1** $I' = 8$ A

STEP 2 From Figure 10.7,

$$E' = (Z' + Z_B)I' = (0.082 + 0.8)(8) = 7.06 \text{ V}$$

STEP 3 From Figure 10.8, $I_e = 0.4$ A

STEP 4 From Figure 10.7, $I = (100/5)(8 + 0.4) = 168$ A

$$\text{CT error} = \frac{0.4}{8.4} \times 100 = 4.8\%$$

CURRENT TRANSFORMER PERFORMANCE- GLOVER BOOK

EXAMPLE

Evaluate the performance of the multiratio CT in Figure 10.8 with a 100:5 CT ratio, for the following secondary output currents and burdens: (a) $I' = 5$ A and $Z_B = 0.5 \Omega$; (b) $I' = 8$ A and $Z_B = 0.8 \Omega$; and (c) $I' = 15$ A and $Z_B = 1.5 \Omega$. Also, compute the CT error for each output current.

c. **STEP 1** $I' = 15$ A

STEP 2 From Figure 10.7,

$$E' = (Z' + Z_B)I' = (0.082 + 1.5)(15) = 23.73 \text{ V}$$

STEP 3 From Figure 10.8, $I_e = 20$ A

STEP 4 From Figure 10.7, $I = (100/5)(15 + 20) = 700$ A

$$\text{CT error} = \frac{20}{35} \times 100 = 57.1\%$$

CURRENT TRANSFORMER PERFORMANCE- GLOVER BOOK

EXAMPLE

Evaluate the performance of the multiratio CT in Figure 10.8 with a 100:5 CT ratio, for the following secondary output currents and burdens: (a) $I' = 5$ A and $Z_B = 0.5 \Omega$; (b) $I' = 8$ A and $Z_B = 0.8 \Omega$; and (c) $I' = 15$ A and $Z_B = 1.5 \Omega$. Also, compute the CT error for each output current.

✓ Notes:

- ***Note 1 : for the 15-A secondary current in (c), high CT saturation causes a large CT error of 57.1%***
- ***Note 2 : Standard practice is to select a CT ratio to give a little less than 5 A secondary output current at maximum normal load.***
- ***Note 3 : From (a), the 100 : 5 CT ratio and 0.5 ohm burden are suitable for a maximum primary load current of about 100 A.***

RELAY OPERATION vs. FAULT CURRENT - GLOVER BOOK

EXAMPLE

An overcurrent relay set to operate at 8 A is connected to the multiratio CT in Figure 10.8 with a 100:5 CT ratio. Will the relay detect a 200-A primary fault current if the burden Z_B is (a) 0.8 Ω , (b) 3.0 Ω ?

SOLUTION Note that if an ideal CT is assumed, $(100/5) \times 8 = 160$ -A primary current would cause the relay to operate.

a. From Example 10.1(b), a 168-A primary current with $Z_B = 0.8 \Omega$ produces a secondary output current of 8 A, which would cause the relay to operate. Therefore, the higher 200-A fault current will also cause the relay to operate.

From previous example:

b. **STEP 1** $I' = 8$ A

STEP 2 From Figure 10.7,

$$E' = (Z' + Z_B)I' = (0.082 + 0.8)(8) = 7.06 \text{ V}$$

STEP 3 From Figure 10.8, $I_c = 0.4$ A

STEP 4 From Figure 10.7, $I = (100/5)(8 + 0.4) = 168$ A

RELAY OPERATION vs. FAULT CURRENT AND CT BURDEN

EXAMPLE

An overcurrent relay set to operate at 8 A is connected to the multiratio CT in Figure 10.8 with a 100:5 CT ratio. Will the relay detect a 200-A primary fault current if the burden Z_B is (a) 0.8 Ω , (b) 3.0 Ω ?

b. **STEP 1** $I' = 8$ A

STEP 2 From Figure 10.7,

$$E' = (Z' + Z_B)I' = (0.05 + 3.0)(8) = 24.4 \text{ V}$$

STEP 3 From Figure 10.8, $I_e = 30$ A

STEP 4 From Figure 10.7, $I = (100/5)(8 + 30) = 760$ A

With a 3.0- Ω burden, 760 A is the lowest primary current that causes the relay to operate. Therefore, the relay will not operate for the 200-A fault current. ■

RELAY OPERATION vs. FAULT CURRENT AND CT BURDEN

Homework: An overcurrent relay set to operate at 10 A is connected to the CT in Figure 10.8 with a 200:5 CT ratio. Determine the minimum primary fault current that the relay will detect if the burden Z_B is (a) 1.0 Ω , (b) 4.0 Ω , and (c) 5.0 Ω .

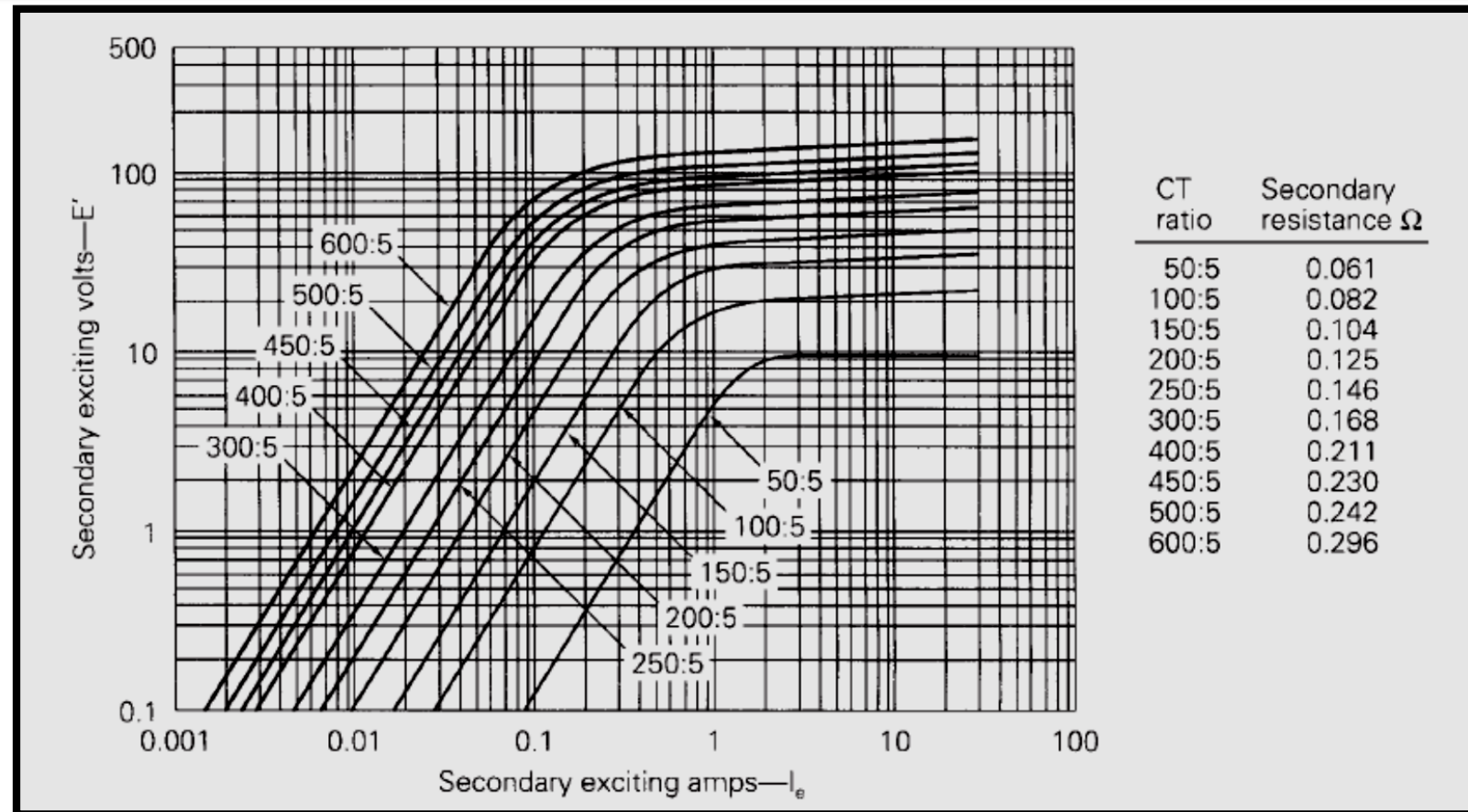

RELAY OPERATION vs. FAULT CURRENT AND CT BURDEN

EXAMPLE

A CT with an excitation curve given in figure below has a rated current ratio of 500:5 A and a secondary leakage impedance of 0.5 ohm. Calculate the CT secondary output current and the CT error for the following cases:

- The impedance of the terminating device is 4.5 ohm and the primary CT load current is 400 A.
- The impedance of the terminating device is 4.5 ohm and the primary CT fault current is 1200 A.
- The impedance of the terminating device is 13.5 ohm and the primary CT load current is 400 A.
- The impedance of the terminating device is 13.5 ohm and the primary CT fault current is 1200 A.

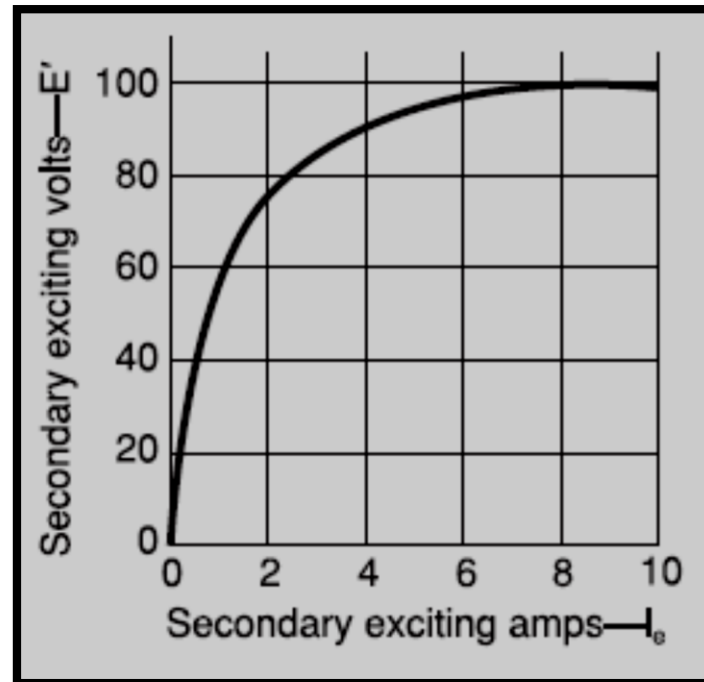

RELAY OPERATION vs. FAULT CURRENT AND CT BURDEN

Solution:

A CT with an excitation curve given in figure below has a rated current ratio of 500:5 A and a secondary leakage impedance of 0.5 ohm. Calculate the CT secondary output current and the CT error for the following cases:

(a) The impedance of the terminating device is 4.5 ohm and the primary CT load current is 400 A.

$$E' = (5)(4 - I_e)$$

Plot this linear equation on the same excitation curve: Read $I_e \cong 0.1 \text{ Amp}$

$$I_2 = \left(\frac{N_1}{N_2} I_1 - I_e \right) = 3.9 \text{ Amp} \text{ and } CT \text{ Error} = \frac{I_e}{I_2 + I_e} = \frac{0.1}{4} = 2.5\%$$

Reminder:

$$I'_2 = \frac{N_1}{N_2} I_1 \text{ and } E' = \frac{N_2}{N_1} V_1$$

$$E' = I_2 (X_2 + X_L)$$

$$E' = (X_2 + X_L)(I'_2 - I_e)$$

$$E' = (X_2 + X_L) \left(\frac{N_1}{N_2} I_1 - I_e \right)$$

$$CT \text{ Error} = \frac{I'_2 - I_2}{I'_2} = \frac{I_e}{I'_2} = \frac{I_e}{I_2 + I_e}$$

RELAY OPERATION vs. FAULT CURRENT AND CT BURDEN

Solution:

(b) The impedance of the terminating device is 4.5 ohm and the primary CT fault current is 1200 A.

$$E' = (5)(12 - I_e)$$

Plot this linear equation on the same excitation curve: Read $I_e \cong 0.8 \text{ Amp}$

$$I_2 = \left(\frac{N_1}{N_2} I_1 - I_e \right) = 11.2 \text{ Amp} \text{ and } CT \text{ Error} = \frac{I_e}{I_2 + I_e} = \frac{0.8}{12} = 6.7\%$$

(c) The impedance of the terminating device is 13.5 ohm and the primary CT load current is 400 A.

$$E' = (14)(4 - I_e)$$

Plot this linear equation on the same excitation curve: Read $I_e \cong 0.6 \text{ Amp}$

$$I_2 = \left(\frac{N_1}{N_2} I_1 - I_e \right) = 3.4 \text{ Amp} \text{ and } CT \text{ Error} = \frac{I_e}{I_2 + I_e} = \frac{0.6}{4} = 15\%$$

(d) The impedance of the terminating device is 13.5 ohm and the primary CT fault current is 1200 A.

$$E' = (14)(12 - I_e)$$

Plot this linear equation on the same excitation curve: Read $I_e \cong 5.4 \text{ Amp}$

$$I_2 = \left(\frac{N_1}{N_2} I_1 - I_e \right) = 6.6 \text{ Amp} \text{ and } CT \text{ Error} = \frac{I_e}{I_2 + I_e} = \frac{5.4}{12} = 45\%$$

Thus, CT error increases with increasing CT current and is further increased by the high terminating impedance.

RELAY OPERATION vs. FAULT CURRENT AND CT BURDEN

