

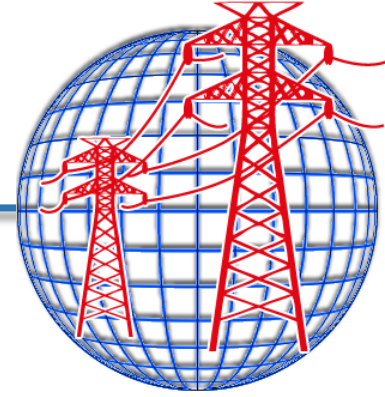

**BIRZEIT UNIVERSITY
FACULTY OF ENGINEERING
AND TECHNOLOGY**



PROTECTION AND AUTOMATION IN ELECTRICAL POWER SYSTEMS

RADIAL SYSTEM PROTECTION

OVERCURRENT RELAYS, FUSES, AND RECLOSERS

By

Dr. Jaser Sa'ed

Department of Electrical and Computer Engineering



OVERCURRENT RELAYS



As shown in figure, the CT secondary current I' is the input to the overcurrent relay operating coil. Instantaneous overcurrent relays respond to the magnitude of their input current, as shown by the trip and block regions in figure. If the current magnitude $I' = |I'|$ exceeds a specified adjustable current magnitude I_p , called the pickup current, then the relay contacts close “instantaneously” to energize the circuit breaker trip coil. If I' is less than the pickup current I_p , then the relay contacts remain open, blocking the trip coil.

OVERCURRENT RELAYS

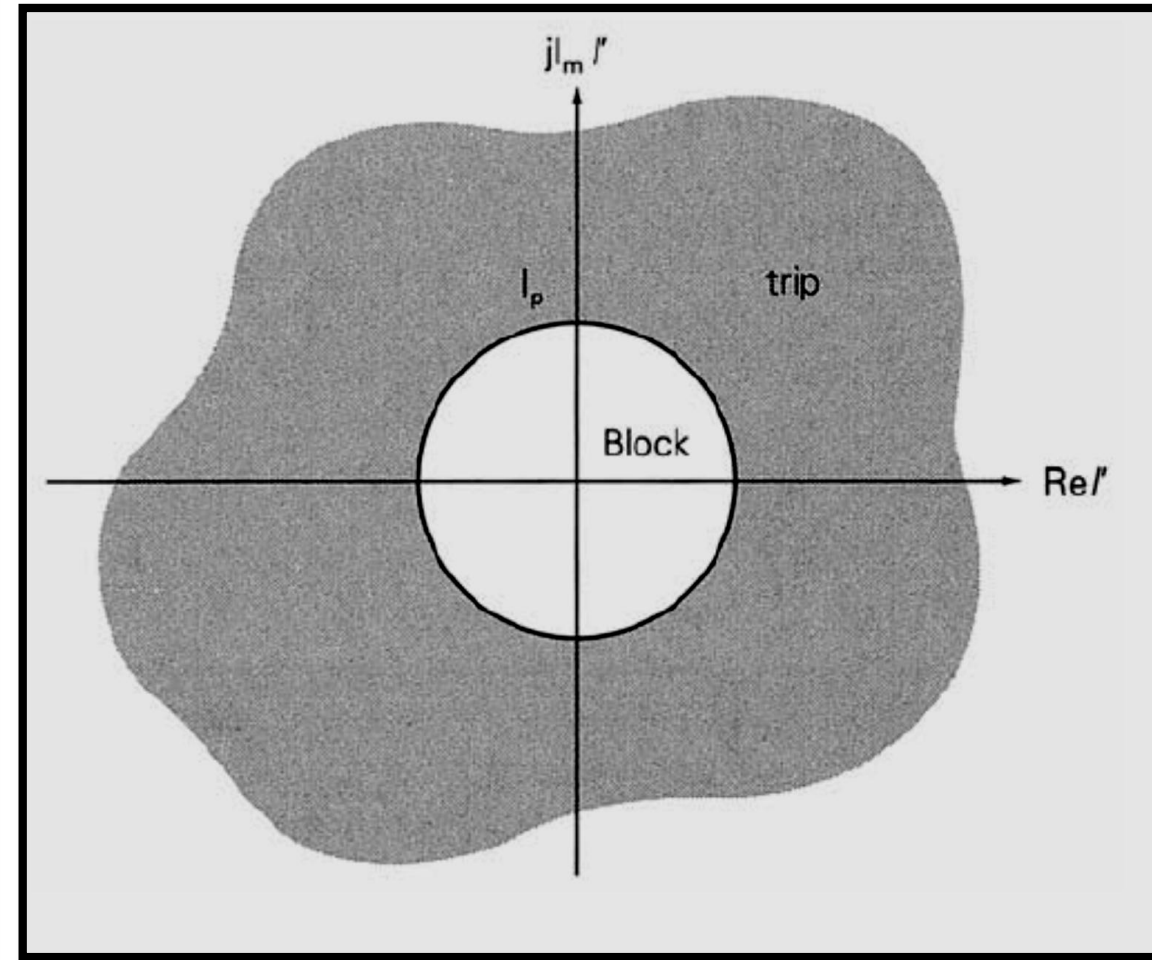
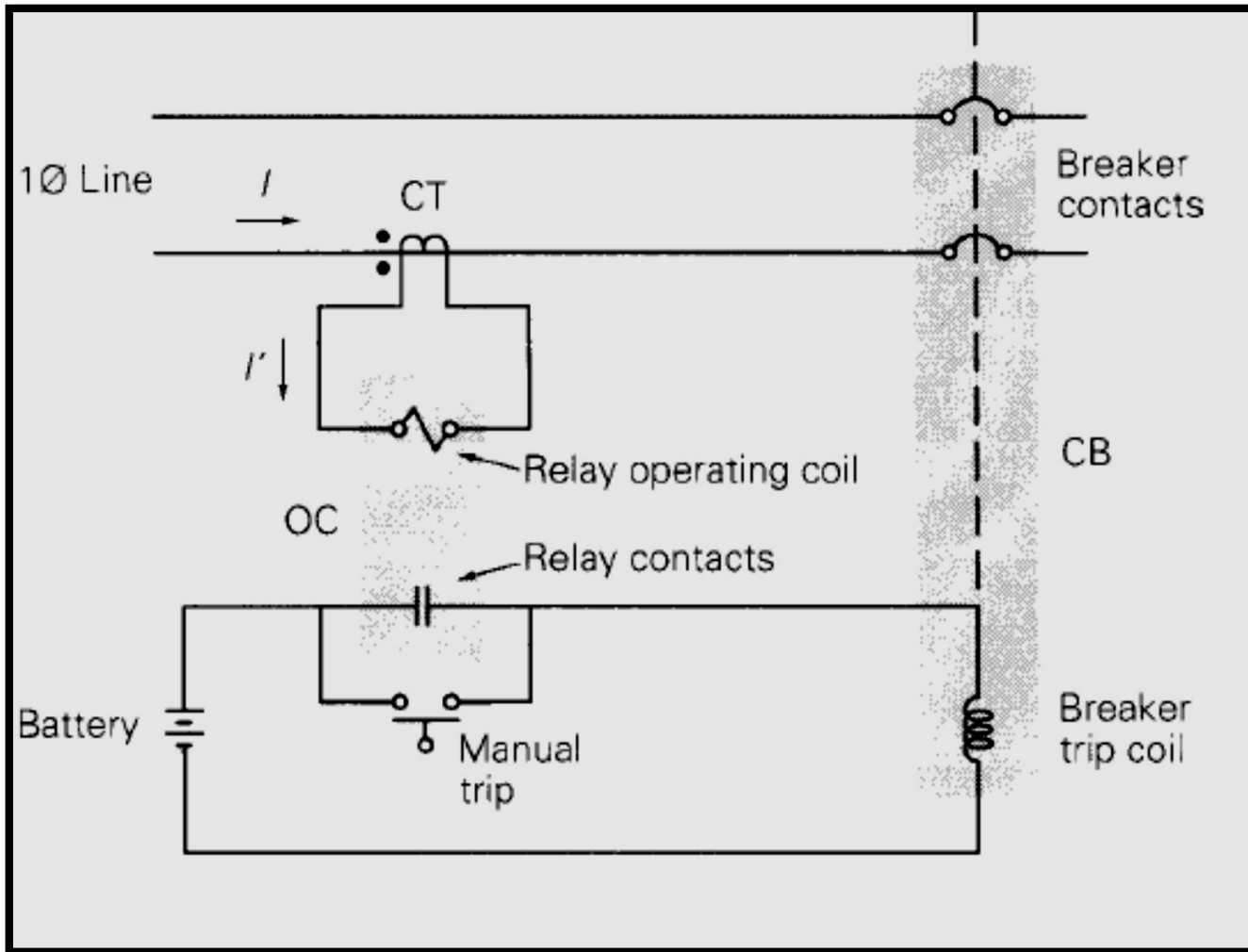

OVERCURRENT RELAYS



Time-delay overcurrent relays also respond to the magnitude of their input current, but with an intentional time delay. As shown in figure, the time delay depends on the magnitude of the relay input current. If I' is a large multiple of the pickup current I_p , then the relay operates (or trips) after a small time delay. For smaller multiples of pickup, the relay trips after a longer time delay. And if $I' < I_p$, the relay remains in the blocking position.

OVERCURRENT RELAYS

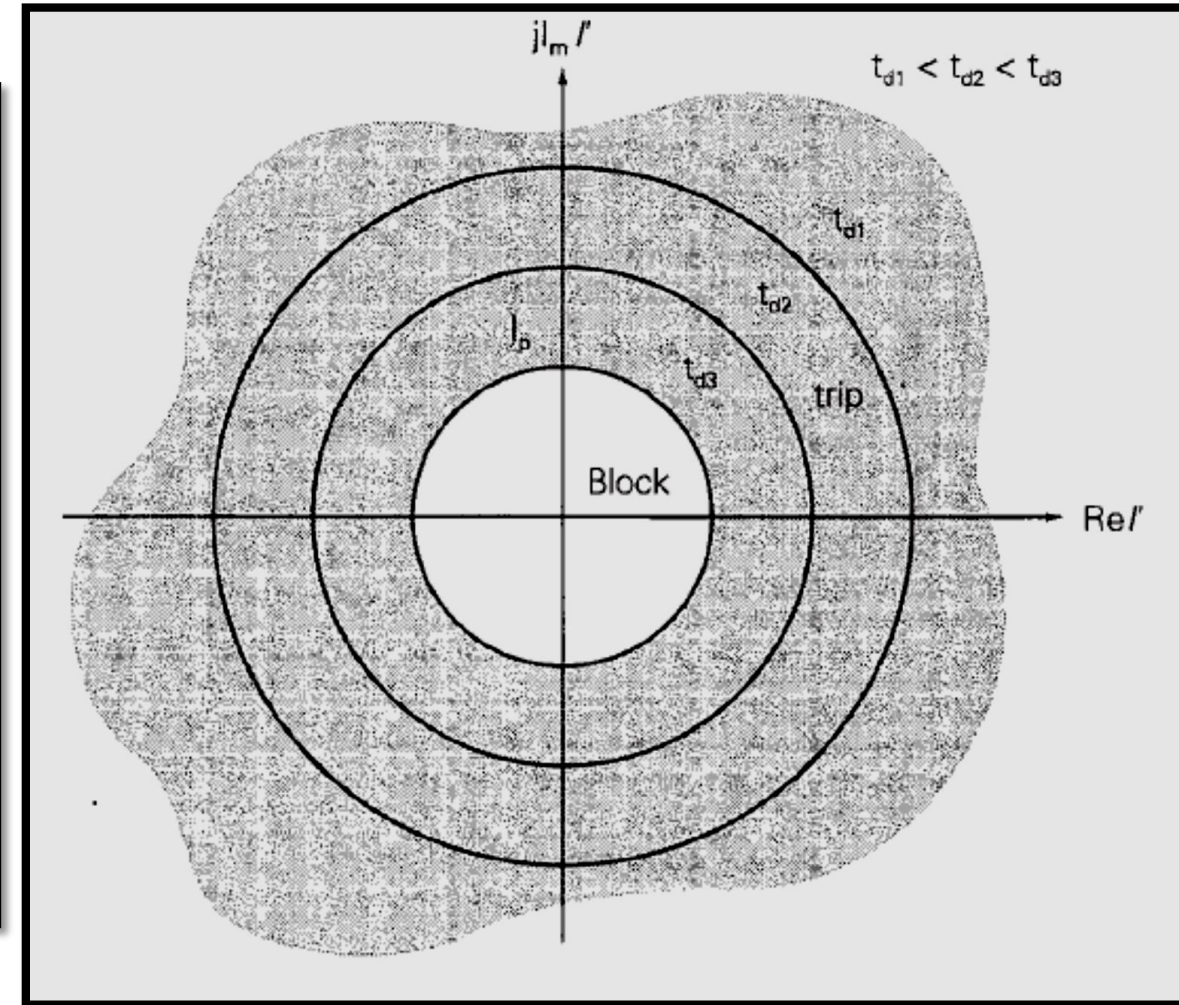
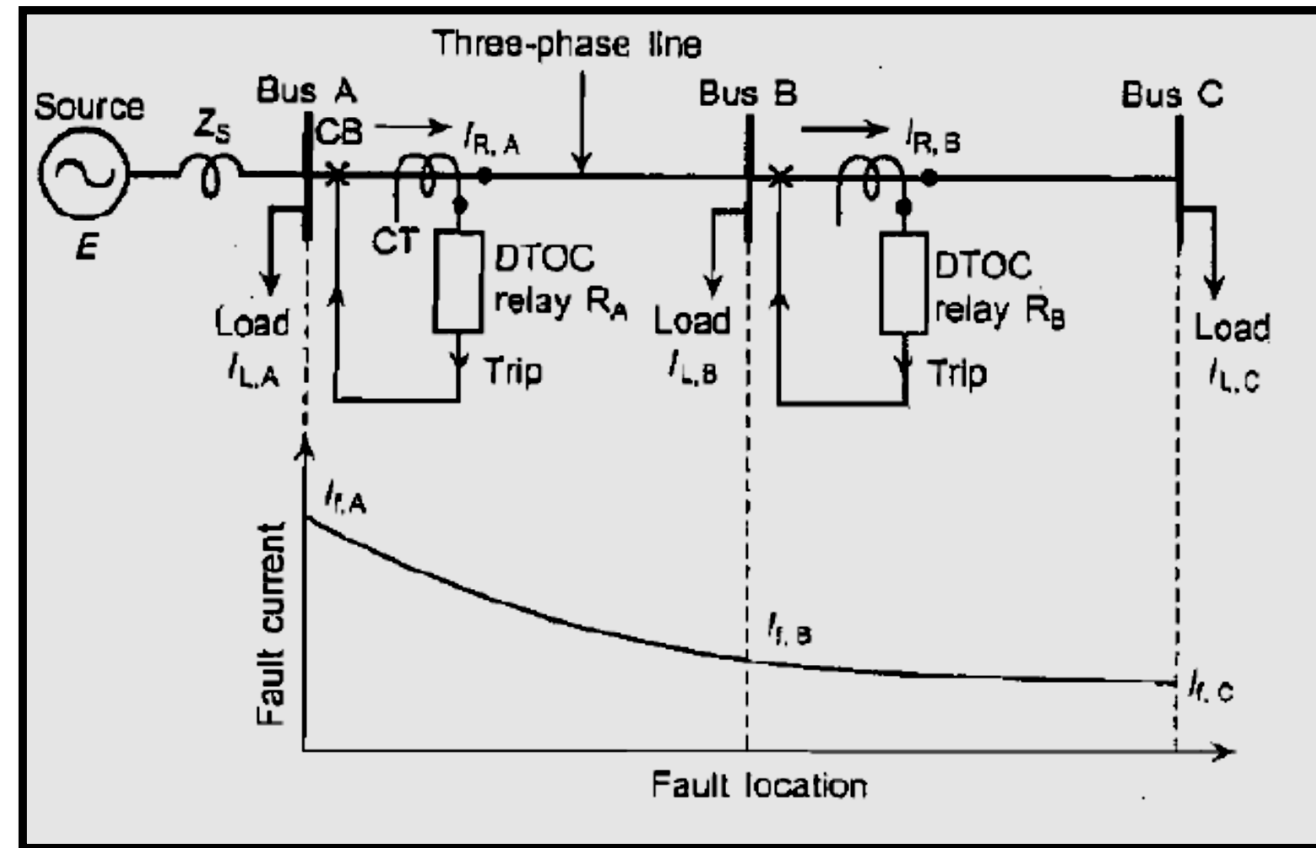

OVERCURRENT RELAYS



OVERCURRENT RELAYS



Over Current Relays have two basic adjustable settings:

- **Current tap setting (CTS): The pickup current in amperes.**
- **Time-dial setting (TDS) : The adjustable amount of time delay.**

CO-8 Time-Delay Overcurrent Relay Characteristics

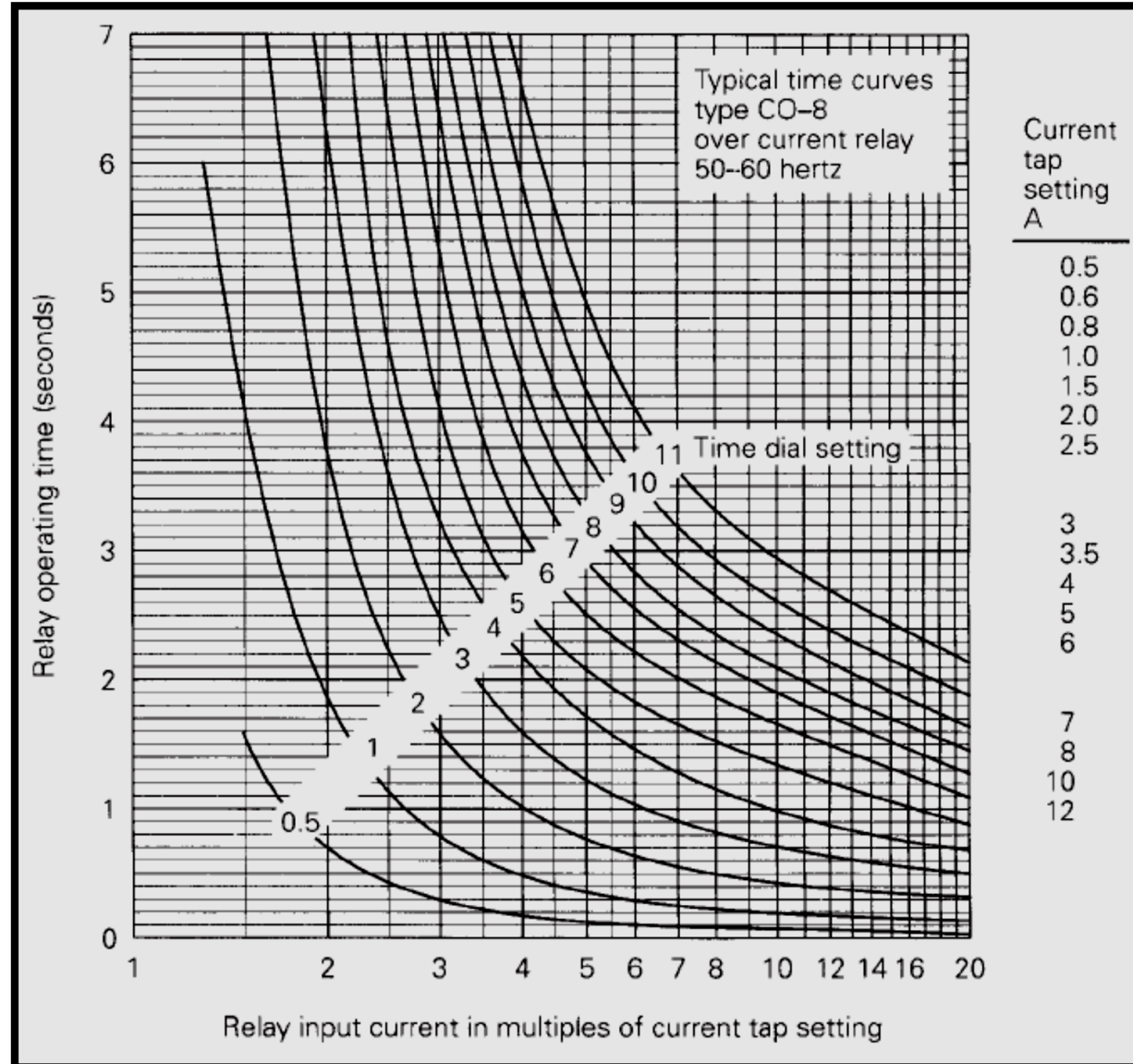

COMPARISON OF CO RELAY CHARACTERISTICS



The next figure shows the time-current characteristics of five CO time delay overcurrent relays used in transmission and distribution lines. The time dial settings are selected in the figure so that all relays operate in 0.2 seconds at 20 times the pickup current. The choice of relay time-current characteristic depends on the sources, lines, and loads. The definite (CO-6) and moderately inverse (CO-7) relays maintain a relatively constant operating time above 10 times pickup. The inverse (CO-8), very inverse (CO-9), and extremely inverse (CO-11) relays operate respectively faster on higher fault currents.

COMPARISON OF CO RELAY CHARACTERISTICS

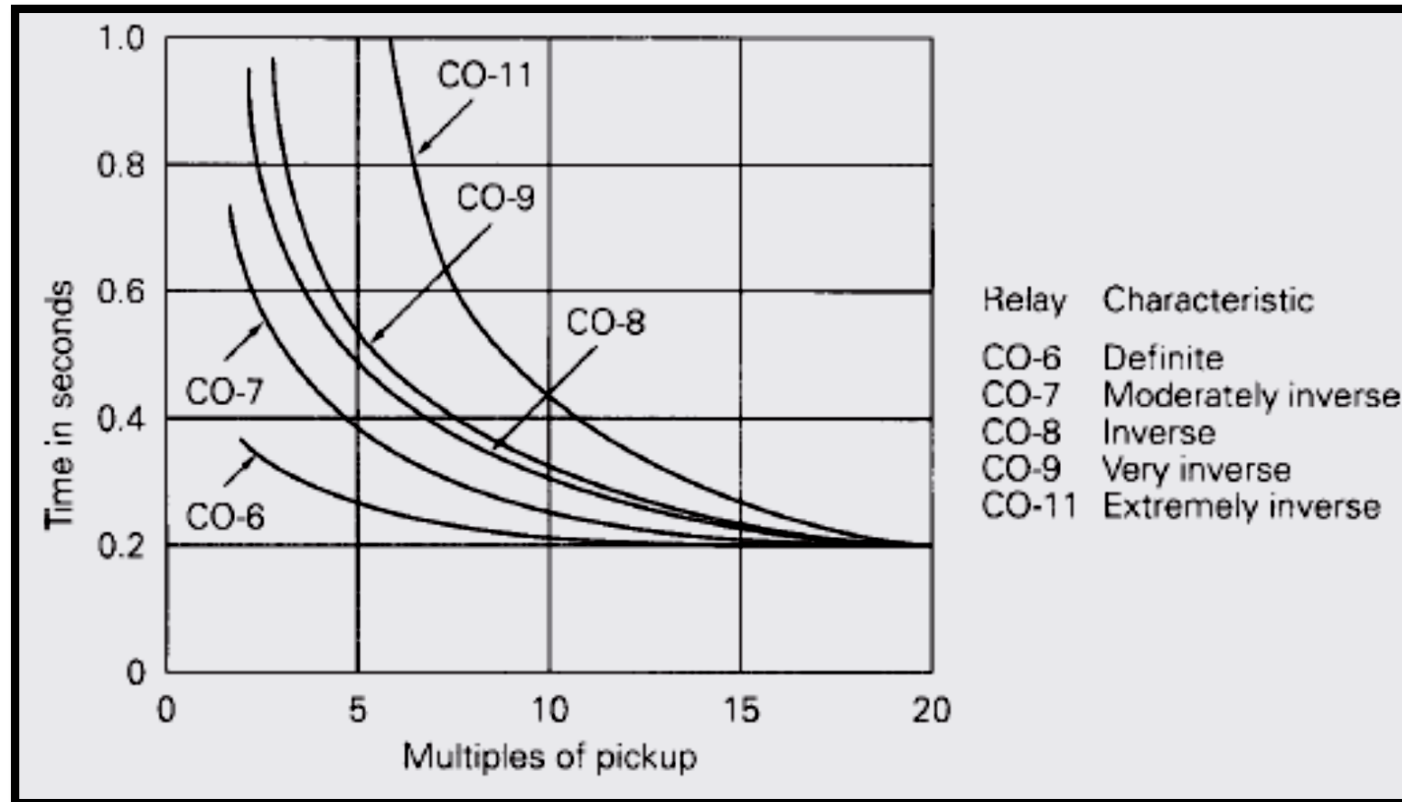

Operating Time for a CO-8 time-Delay Overcurrent Relay

EXAMPLE The CO-8 relay with a current tap setting of 6 amperes and a time-dial setting of 1 is used with the 100 : 5 CT. Determine the relay operating time for the cases.

a) $I' = 5 A$

b) $I' = 8 A$

c) $I' = 15 A$

$$I' = 5 A \quad \frac{I'}{I_p} = \frac{5}{6} = 0.83$$

The relay does not operate. It remains in the blocking position.

$$I' = 8 A \quad \frac{I'}{I_p} = \frac{8}{6} = 1.33$$

$$t_{\text{operating}} = 6 \text{ seconds.}$$

$$I' = 15 A \quad \frac{I'}{I_p} = \frac{15}{6} = 2.5$$

$$t_{\text{operating}} = 1.2 \text{ seconds.}$$

RADIAL SYSTEM PROTECTION



Many radial systems are protected by time-delay overcurrent relays. Adjustable time delays can be selected such that the breaker closest to the fault opens, while other upstream breakers with larger time delays remain closed. That is, the relays can be coordinated to operate in sequence so as to interrupt minimum load during faults. Successful relay coordination is obtained when fault currents are much larger than normal load currents. Also, coordination of overcurrent relays usually limits the maximum number of breakers in a radial system to five or less, otherwise the relay closest to the source may have an excessive time delay.

RADIAL SYSTEM PROTECTION

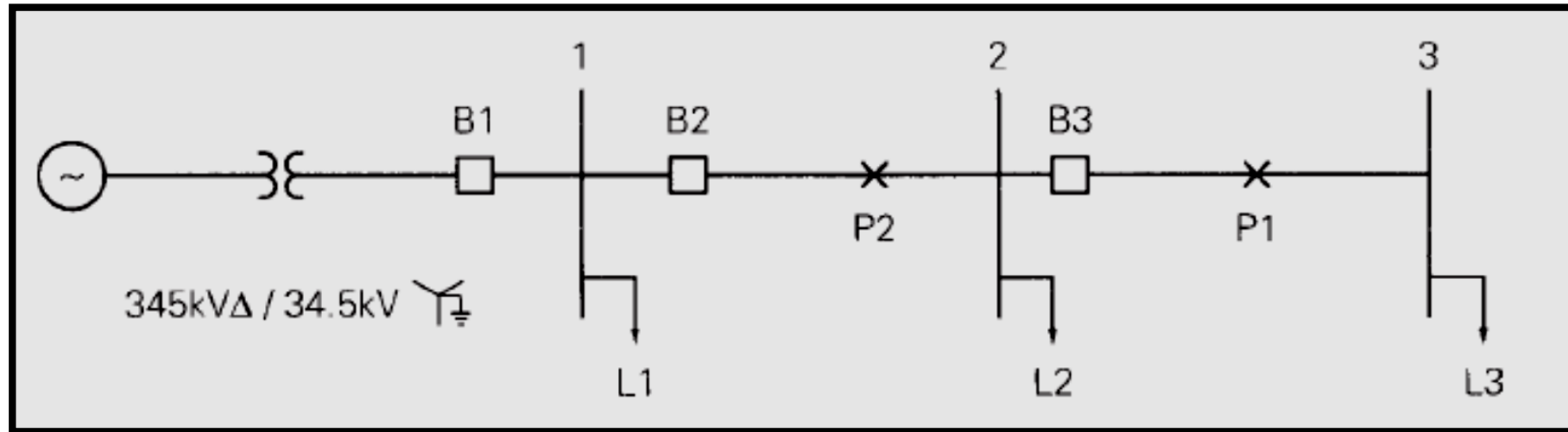

RADIAL SYSTEM PROTECTION



Consider a fault at P₁ to the right of breaker B₃ for the radial system. For this fault we want breaker B₃ to open while B₂ (and B₁) remains closed. Under these conditions, only load L₃ is interrupted. We could select a longer time delay for the relay at B₂, so that B₃ operates first. Thus, for any fault to the right of B₃, B₃ provides primary protection. Only if B₃ fails to open will B₂ open, after time delay, thus providing backup protection.

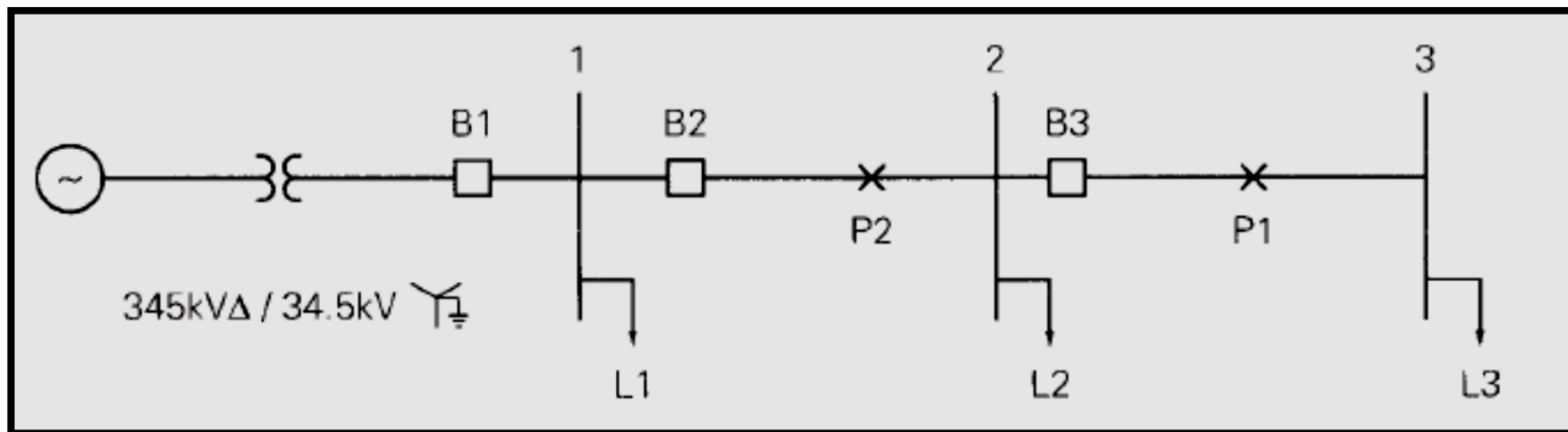

RADIAL SYSTEM PROTECTION



Similarly, consider a fault at P2 between B2 and B3. We want B2 to open while B1 remains closed. Under these conditions, loads L2 and L3 are interrupted. Since the fault is closer to the source, the fault current will be larger than for the previous fault considered. B2, set to open for the previous, smaller fault current after time delay, will open more rapidly for this fault. We also select the B1 relay with a longer time delay than B2, so that B2 opens first. Thus, B2 provides primary protection for faults between B2 and B3, as well as backup protection for faults to the right of B3. Similarly, B1 provides primary protection for faults between B1 and B2, as well as backup protection for further downstream faults.

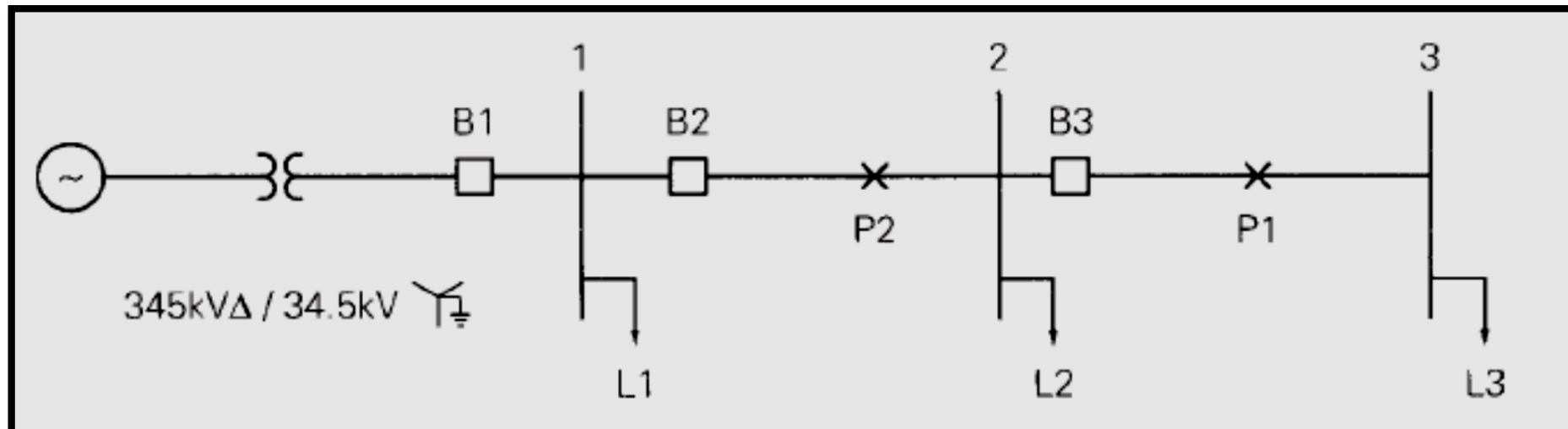

RADIAL SYSTEM PROTECTION



The **coordination time interval** is the time interval between the primary and remote backup protective devices. It is the difference between the time that the backup relaying operates and the time that circuit breakers clear the fault under primary relaying. Precise determination of relay operating times is complicated by several factors, including CT error, dc offset component of fault current, and relay over travel. Therefore, typical coordination time intervals from 0.2 to 0.5 seconds are selected to account for these factors in most practical applications.

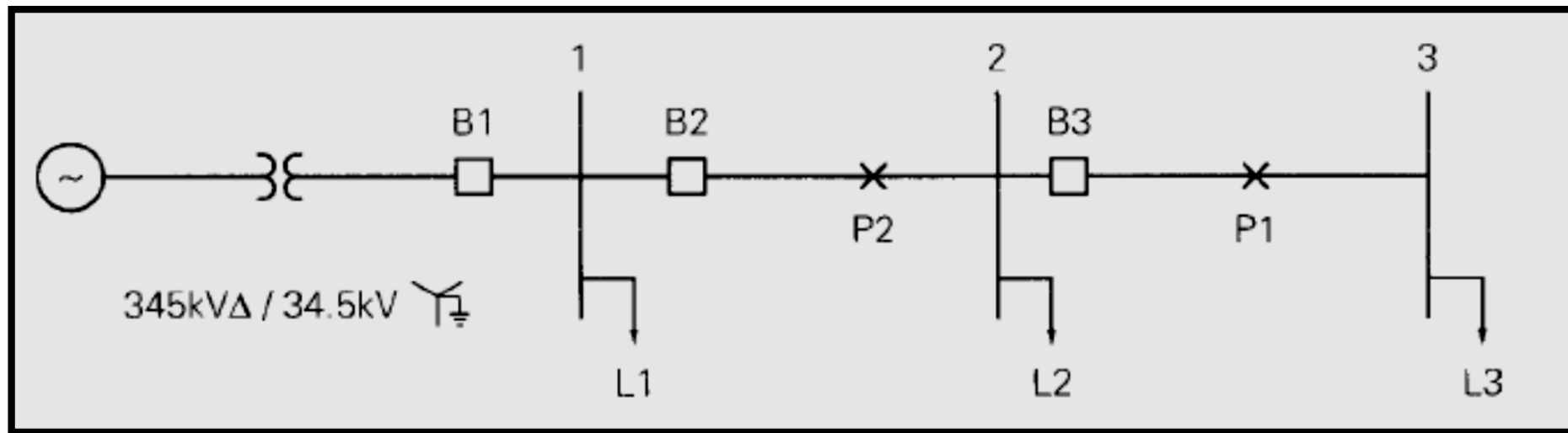

RADIAL SYSTEM PROTECTION- EXAMPLE



EXAMPLE 10.4 Coordinating time-delay overcurrent relays in a radial system

Data for the 60-Hz radial system of Figure 10.16 are given in Tables 10.3, 10.4, and 10.5. Select current tap settings (TSs) and time-dial settings (TDSs)

to protect the system from faults. Assume three CO-8 relays for each breaker, one for each phase, with a 0.3-second coordination time interval. The relays for each breaker are connected as shown in Figure 10.17, so that all three phases of the breaker open when a fault is detected on any one phase. Assume a 34.5-kV (line-to-line) voltage at all buses during normal operation. Also, future load growth is included in Table 10.3, such that maximum loads over the operating life of the radial system are given in this table.

RADIAL SYSTEM PROTECTION- EXAMPLE

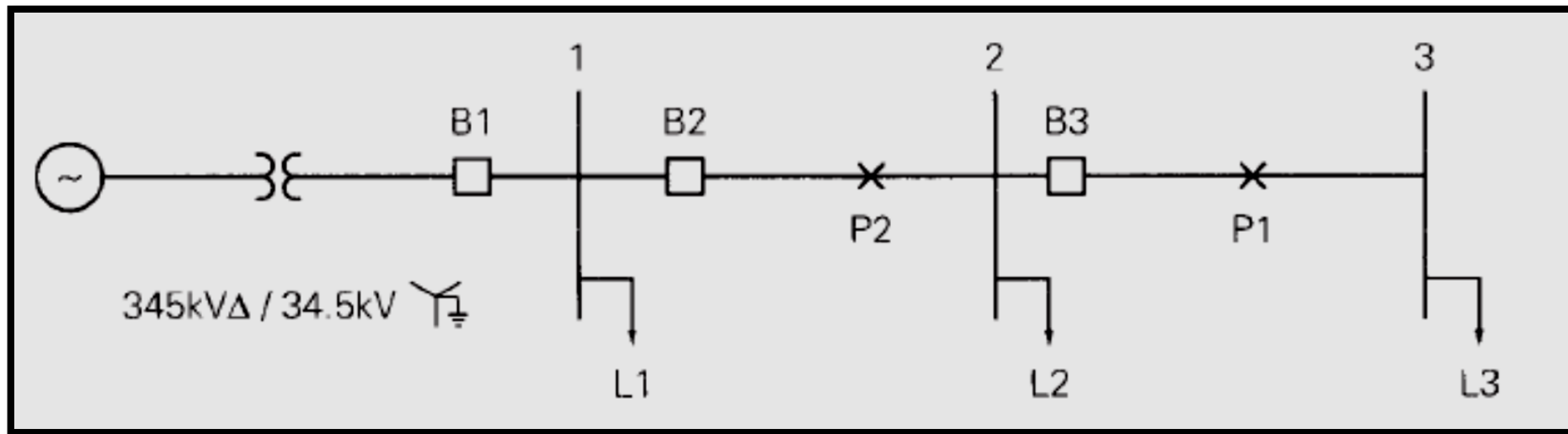

RADIAL SYSTEM PROTECTION- EXAMPLE

TABLE 10.3

Maximum loads—
Example 10.4

Bus	S MVA	Lagging p.f.
1	11.0	0.95
2	4.0	0.95
3	6.0	0.95

TABLE 10.4

Symmetrical fault
currents—Example 10.4

Bus	Maximum Fault Current (Bolted Three-Phase) A	Minimum Fault Current (L–G or L–L) A
1	3000	2200
2	2000	1500
3	1000	700

RADIAL SYSTEM PROTECTION- EXAMPLE

TABLE 10.5

Breaker, CT, and relay data—Example 10.4

Breaker	Breaker Operating Time	CT Ratio	Relay
B1	5 cycles	400 :5	CO-8
B2	5 cycles	200 :5	CO-8
B3	5 cycles	200 :5	CO-8

RADIAL SYSTEM PROTECTION- EXAMPLE

FIGURE 10.17

Relay connections to trip all three phases

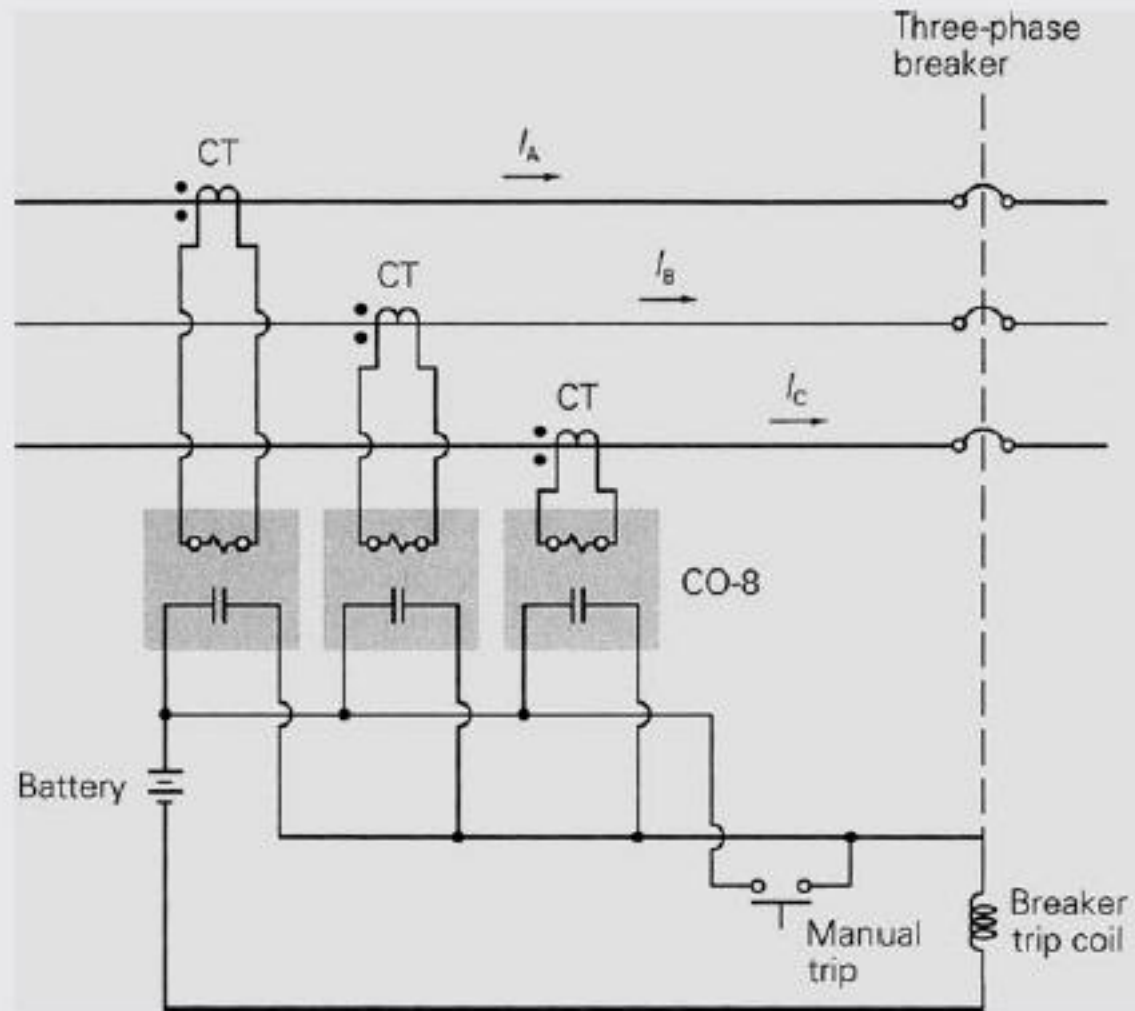

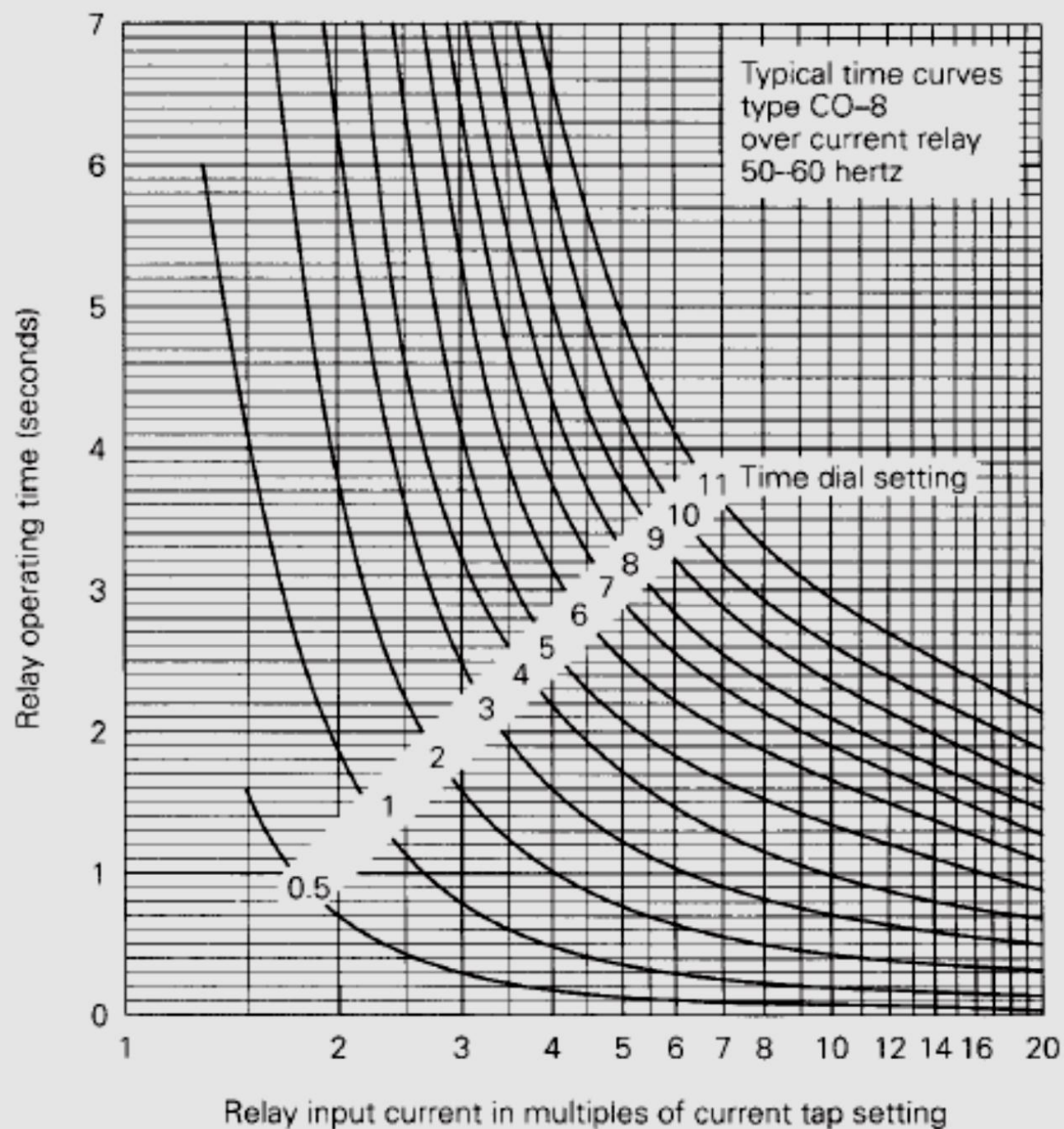

Current
tap
setting
A

0.5
0.6
0.8
1.0
1.5
2.0
2.5

3
3.5
4
5
6

7
8
10
12

RADIAL SYSTEM PROTECTION- EXAMPLE

SOLUTION First, select TSs such that the relays do not operate for maximum load currents. Starting at B3, the primary and secondary CT currents for maximum load L3 are

$$I_{L3} = \frac{S_{L3}}{V_3 \sqrt{3}} = \frac{6 \times 10^6}{(34.5 \times 10^3) \sqrt{3}} = 100.4 \text{ A}$$

$$I'_{L3} = \frac{100.4}{(200/5)} = 2.51 \text{ A}$$

From Figure 10.12, we select for the B3 relay a 3-A TS, which is the lowest TS above 2.51 A.

RADIAL SYSTEM PROTECTION- EXAMPLE

Note that $|S_{L2} + S_{L3}| = |S_{L2}| + |S_{L3}|$ because the load power factors are identical. Thus, at B2, the primary and secondary CT currents for maximum load are

$$I_{L2} = \frac{S_{L2} + S_{L3}}{V_2 \sqrt{3}} = \frac{(4 + 6) \times 10^6}{(34.5 \times 10^3) \sqrt{3}} = 167.3 \text{ A}$$

$$I'_{L2} = \frac{167.3}{(200/5)} = 4.18 \text{ A}$$

From Figure 10.12, select for the B2 relay a 5-A TS, the lowest TS above 4.18 A. At B1,

$$I_{L1} = \frac{S_{L1} + S_{L2} + S_{L3}}{V_1 \sqrt{3}} = \frac{(11 + 4 + 6) \times 10^6}{(34.5 \times 10^3) \sqrt{3}} = 351.4 \text{ A}$$

$$I'_{L1} = \frac{351.4}{(400/5)} = 4.39 \text{ A}$$

Select a 5-A TS for the B1 relay.

RADIAL SYSTEM PROTECTION- EXAMPLE

Next select the TDSs. We first coordinate for the maximum fault currents in Table 10.4, checking coordination for minimum fault currents later. Starting at B3, the largest fault current through B3 is 2000 A, which occurs for the three-phase fault at bus 2 (just to the right of B3). Neglecting CT saturation, the fault-to-pickup current ratio at B3 for this fault is

$$\frac{I'_{3\text{Fault}}}{\text{TS3}} = \frac{2000/(200/5)}{3} = 16.7$$

Since we want to clear faults as rapidly as possible, select a 1/2 TDS for the B3 relay. Then, from the 1/2 TDS curve in Figure 10.12, the relay operating time is $T_3 = 0.05$ seconds. Adding the breaker operating time (5 cycles = 0.083 s), primary protection clears this fault in $T_3 + T_{\text{breaker}} = 0.05 + 0.083 = 0.133$ seconds.

RADIAL SYSTEM PROTECTION- EXAMPLE

For this same fault, the fault-to-pickup current ratio at B2 is

$$\frac{I'_{2\text{Fault}}}{\text{TS2}} = \frac{2000 / (200 / 5)}{5} = 10.0$$

Adding the B3 relay operating time ($T_3 = 0.05$ s), breaker operating time (0.083 s), and 0.3 s coordination time interval, we want a B2 relay operating time

$$T_2 = T_3 + T_{\text{breaker}} + T_{\text{coordination}} = 0.05 + 0.083 + 0.3 \approx 0.43 \text{ s}$$

From Figure 10.12, select $\text{TDS2} = 2$.

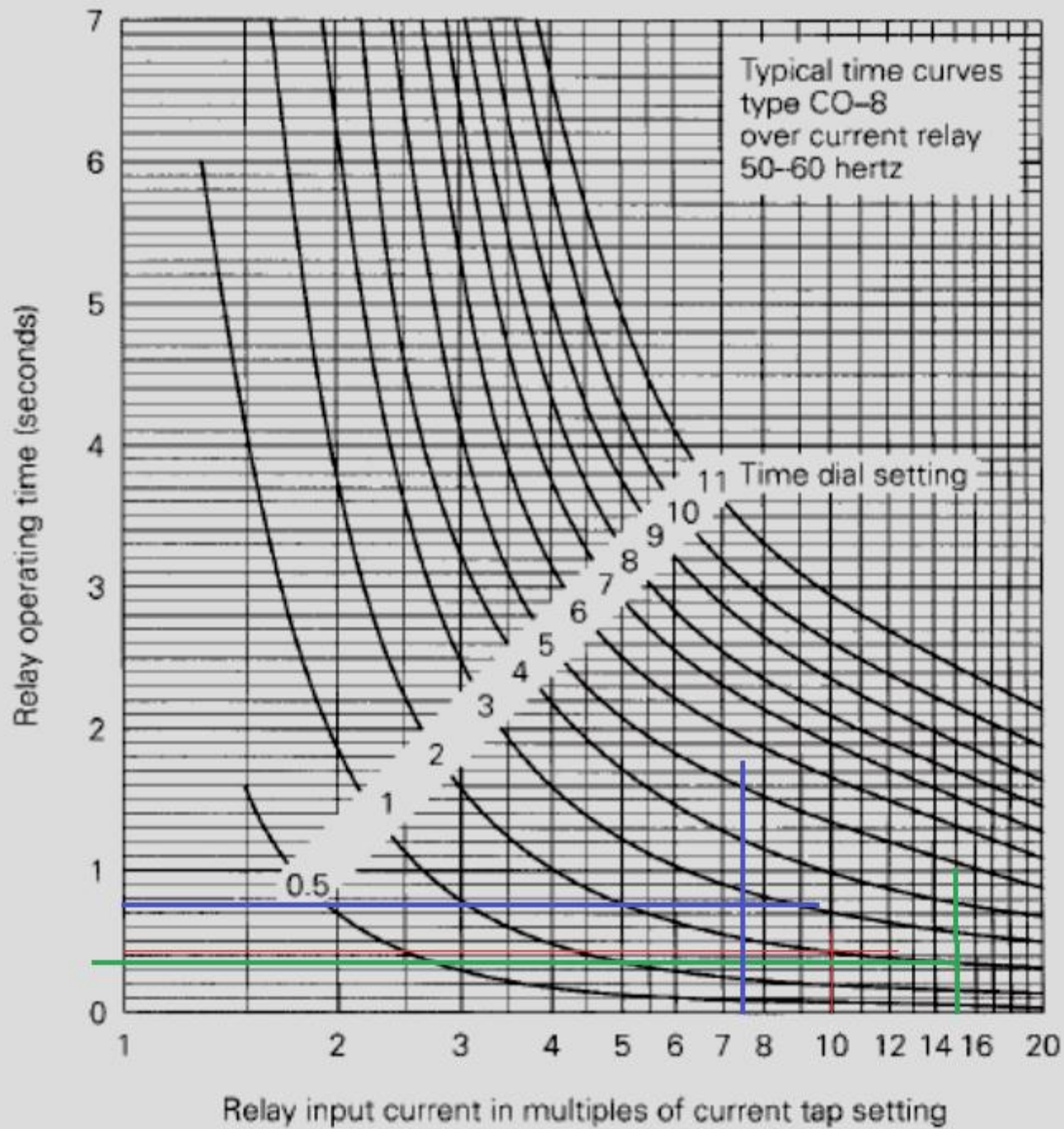

Current
tap
setting
A

0.5
0.6
0.8
1.0
1.5
2.0
2.5

3
3.5
4
5
6

7
8
10
12

RADIAL SYSTEM PROTECTION- EXAMPLE

Next select the TDS at B1. The largest fault current through B2 is 3000 A, for a three-phase fault at bus 1 (just to the right of B2). The fault-to-pickup current ratio at B2 for this fault is

$$\frac{I'_{2\text{Fault}}}{\text{TS2}} = \frac{3000/(200/5)}{5} = 15.0$$

From the 2 TDS curve in Figure 10.12, $T_2 = 0.38$ s. For this same fault,

$$\frac{I'_{1\text{Fault}}}{\text{TS1}} = \frac{3000/(400/5)}{5} = 7.5$$

$$T_1 = T_2 + T_{\text{breaker}} + T_{\text{coordination}} = 0.38 + 0.083 + 0.3 \approx 0.76 \text{ s}$$

From Figure 10.12, select $\text{TDS1} = 3$. The relay settings are shown in Table 10.6. Note that for reliable relay operation the fault-to-pickup current ratios with minimum fault currents should be greater than 2. Coordination for minimum fault currents listed in Table 10.4 is evaluated in Problem 10.11. ■

RADIAL SYSTEM PROTECTION- EXAMPLE

Breaker	Relay	TS	TDS
B1	CO-8	5	3
B2	CO-8	5	2
B3	CO-8	3	1/2

RADIAL SYSTEM PROTECTION- HOMEWORK

An 11-kV radial system is shown in Figure 10.42. Assuming a CO-7 relay with relay characteristic given in Figure 10.41 and the same power factor for all loads, select relay settings to protect the system.

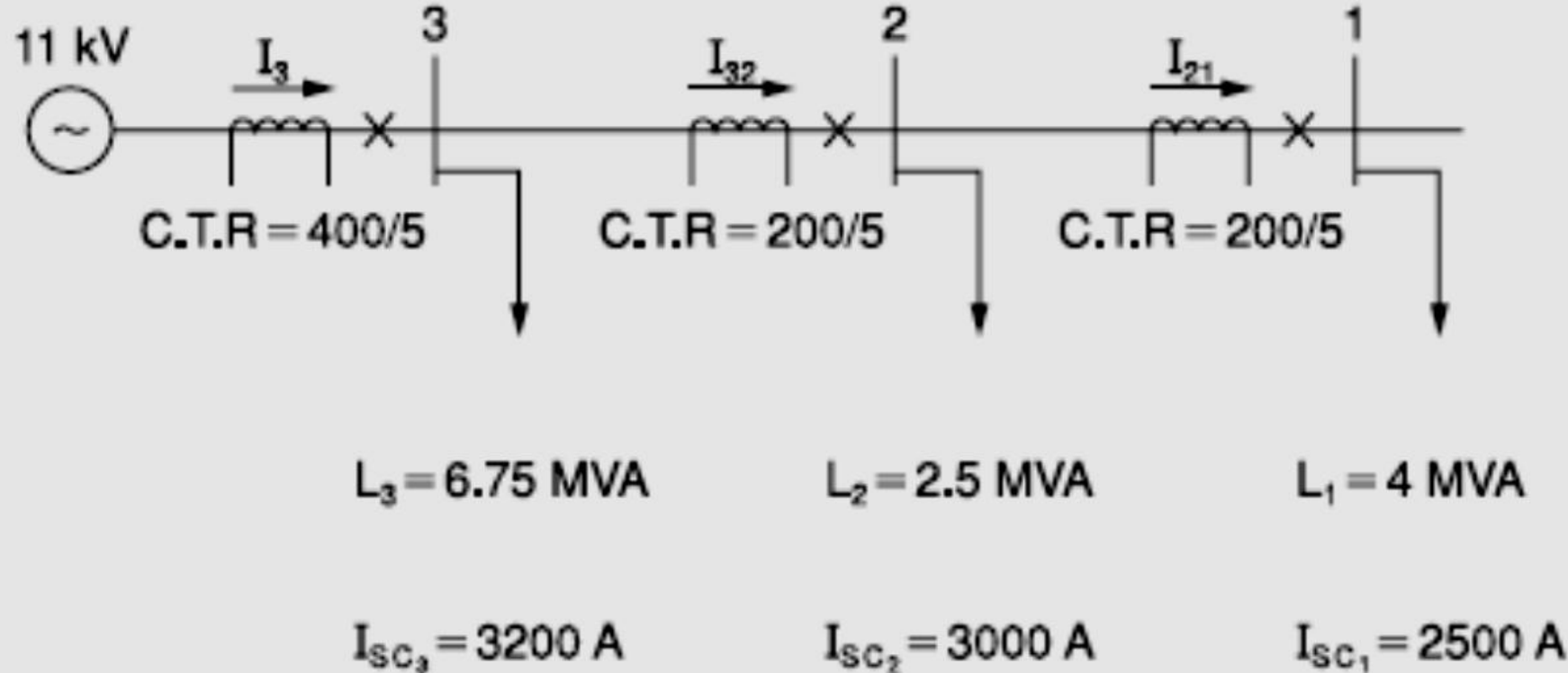

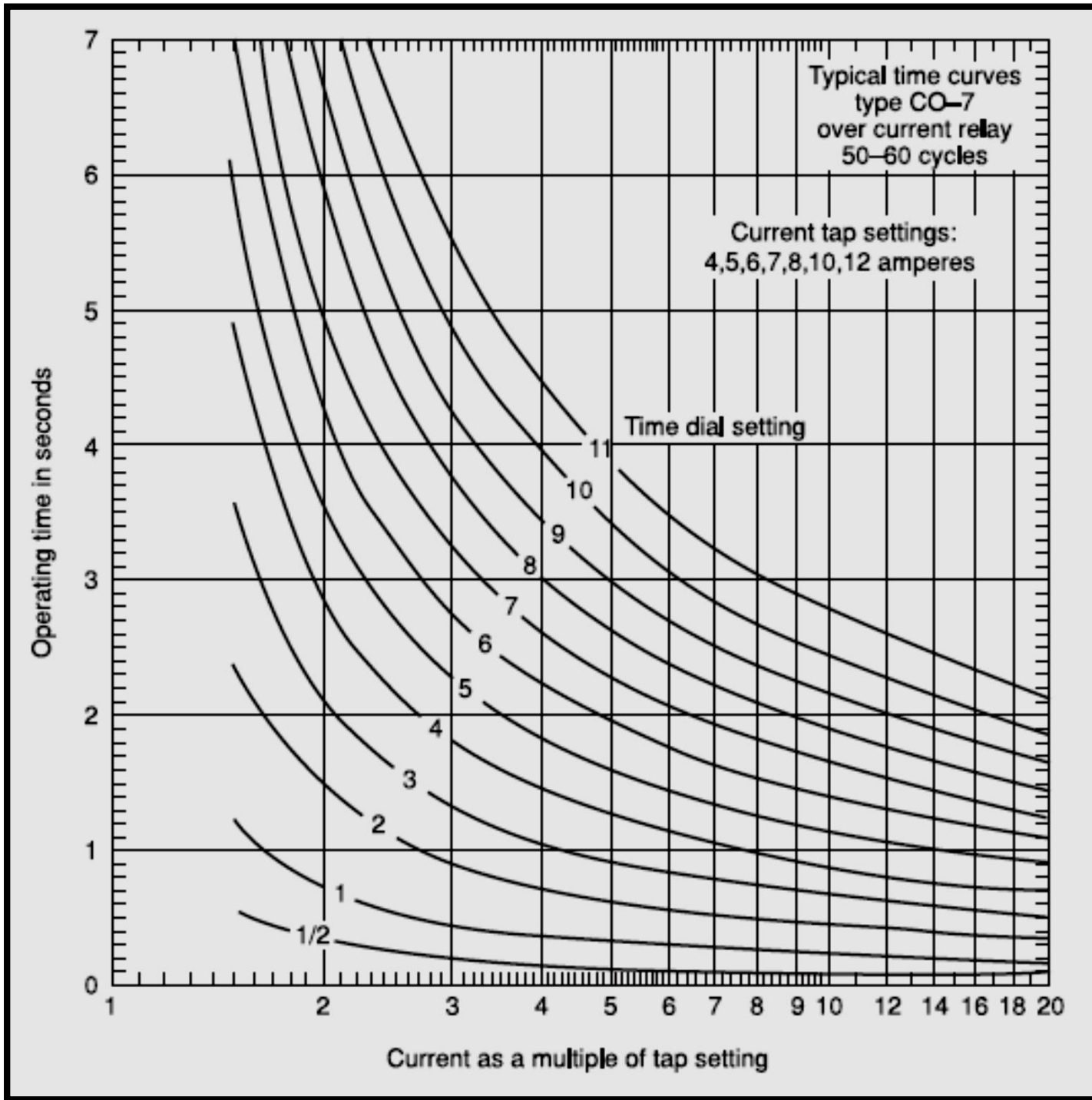

FUSE CHARACTERISTICS



Any fault protective device must be selected with regard to three different ratings: the voltage rating, the continuous (load) current rating, and the interrupting rating. The voltage rating must be high enough to withstand voltages normally experienced in system operation. The continuous current rating must be adequate for the normal load current that is expected to flow in the circuit of application. This current rating is often chosen to exceed the maximum load current by a margin of 30% or so, at the time of installation, in order to allow for future load growth. The interrupting rating refers to the highest current the device will be called upon to interrupt at rated voltage. This rating is often expressed in MVA.

Fuse Time-Current Characteristics



A fuse is an "overcurrent protective device with a circuit-opening fusible part that is heated and severed by the passage of overcurrent through it" [*]. For circuits operating at 600 volts and above, fuses are called "power fuses,"

[*] IEEE Std 100-1992, IEEE Standard Dictionary of Electrical and Electronics Terms, John Wiley & Sons. Inc., New York, 1992.

Fuse-Fuse Coordination



A fuse has two characteristics: Minimum Melting (MM) and Total Clearing (TC). MM characteristics gives time in which fuse can be damaged for a given value of fault current. TC characteristic gives the fault clearing time of fuse for given value of fault current.

Fuse-Fuse Coordination



Figure a, shows a fuse-fuse coordination scheme without DG; when a fault occurs at location B, fuse 1 and fuse 2 would see the same fault current injected by the utility grid. For conventional distribution system fuse 1 should act faster than fuse 2 to isolate as minimum part of the system as possible. This would be achieved if TC characteristic of fuse 1 is below the MM characteristics of fuse 2 by a safe margin for any fault on location B. Figure b shows the coordination graph. It shows the fuses are coordinated for all fault currents within I_{fmin} and I_{fmax} ; this is called the coordination range. Therefore, as long as the fault current values for faults on location B are within coordination range, the fuses are coordinated.

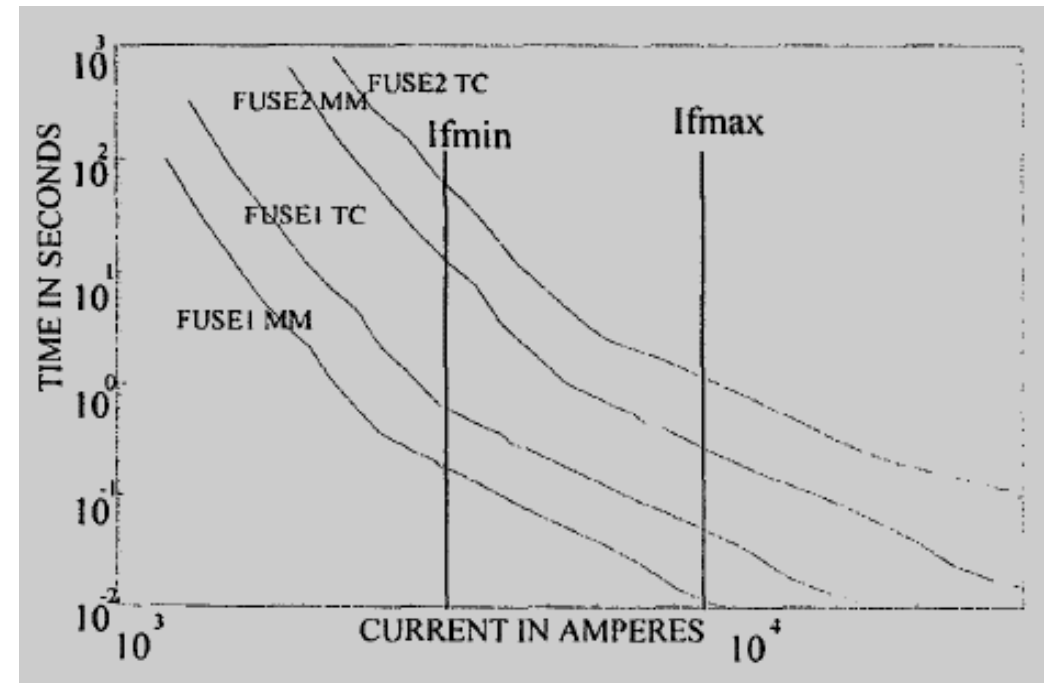
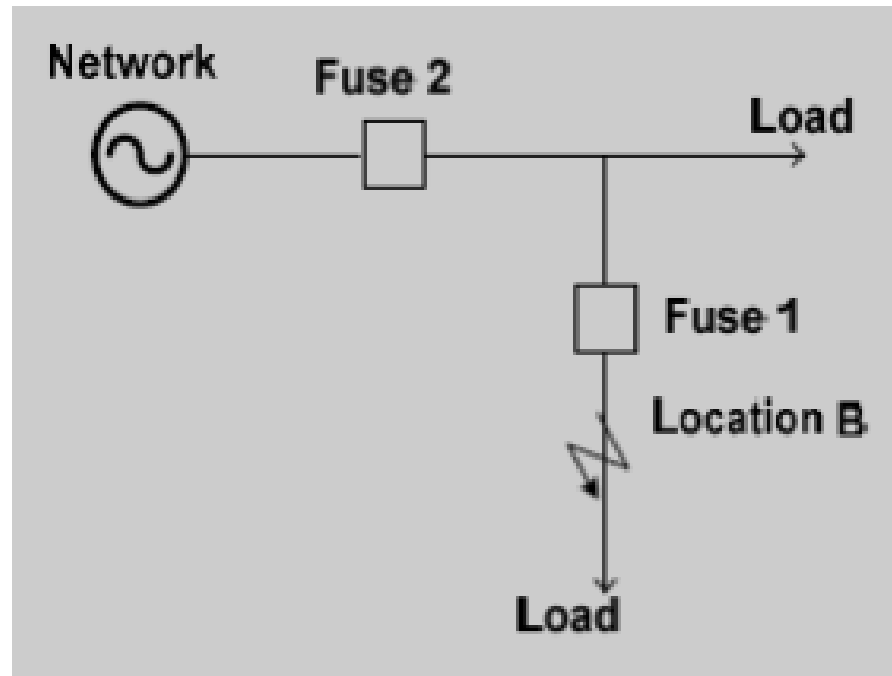

Fuse-Fuse Coordination



This coordination scheme will not fit well after adding DG. For a fault at location A after adding DG, both fuses see the same fault current as shown in Figure 2-b. In this case fuse 2 should act faster than fuse 1 which contrasts with the original fuse-fuse coordination before adding DG. It is clear that the fuse-fuse coordination requirement for an upstream fault in the presence of DG is in contradiction with the fuse coordination requirement in the absence of DG.

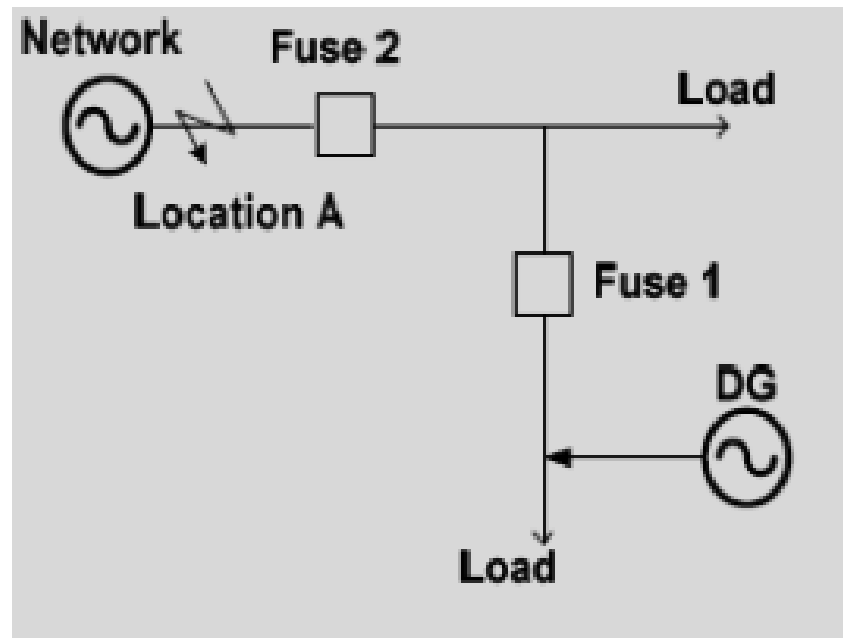

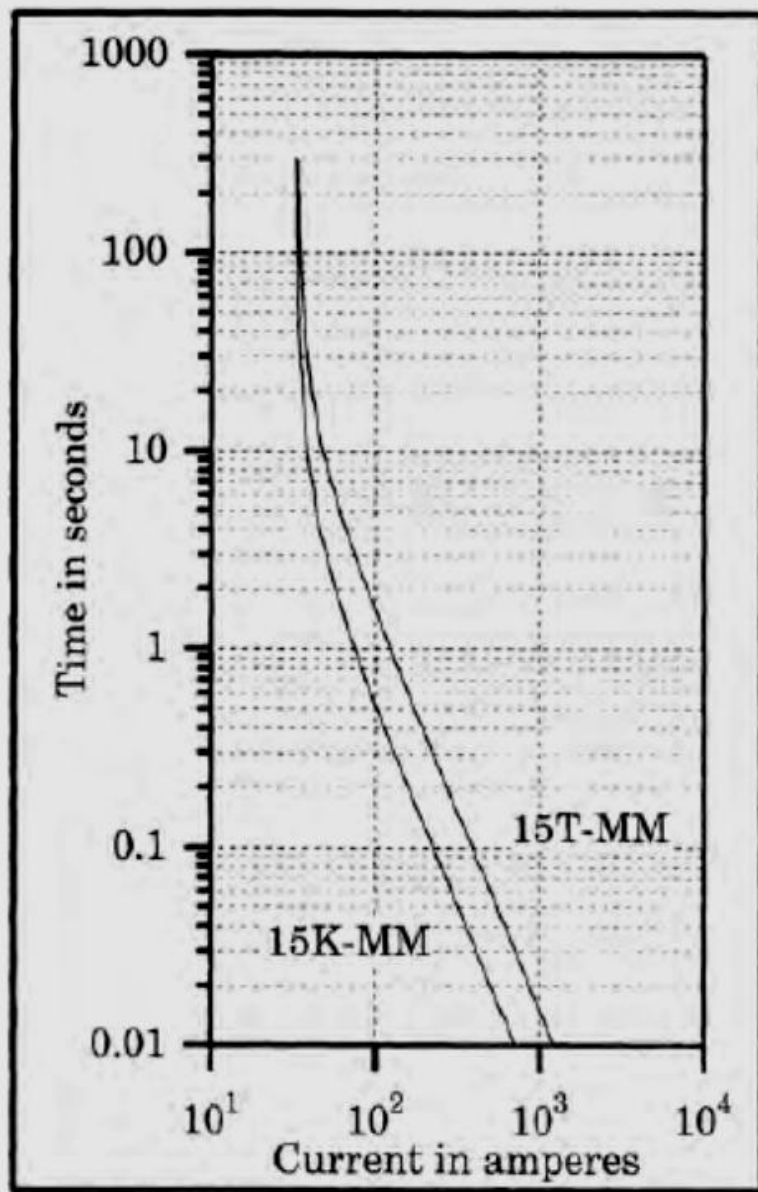

Figure 3.5 Type K (fast) and type T (time delayed) time-current curves of the same current rating.

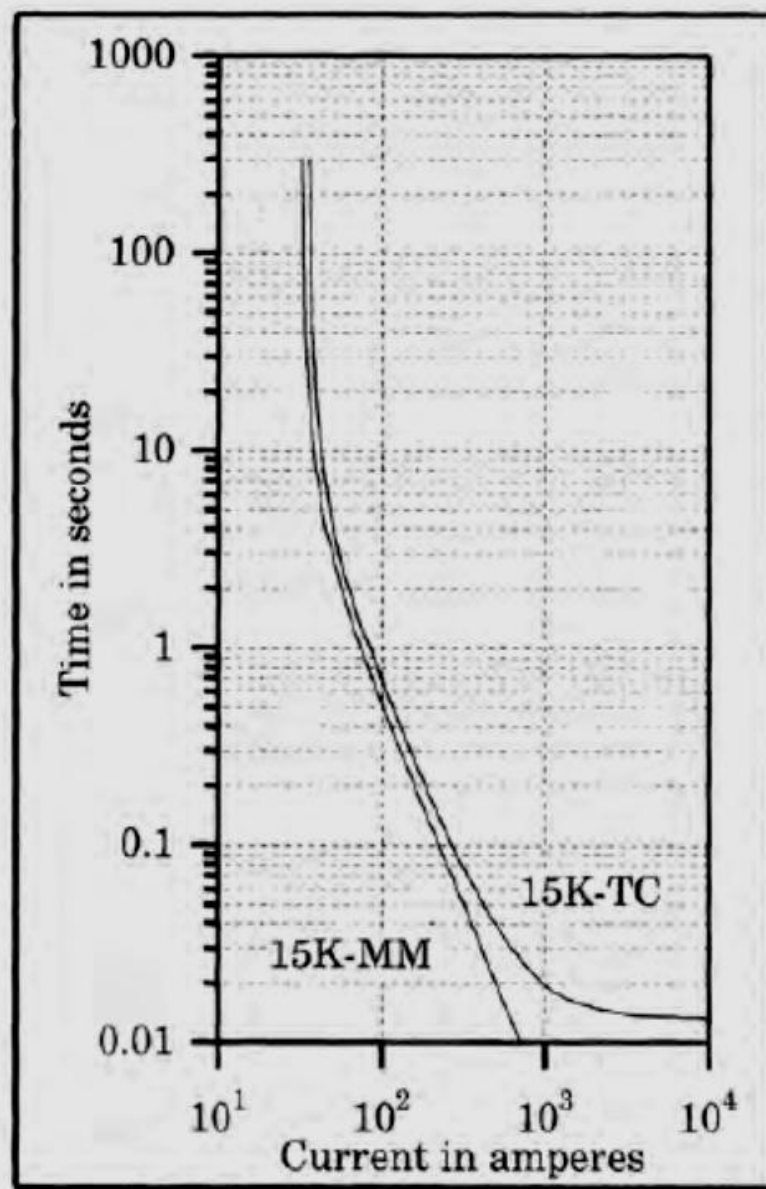

Figure 3.6 Type K (fast) minimum melting and total clearing time-current curves.

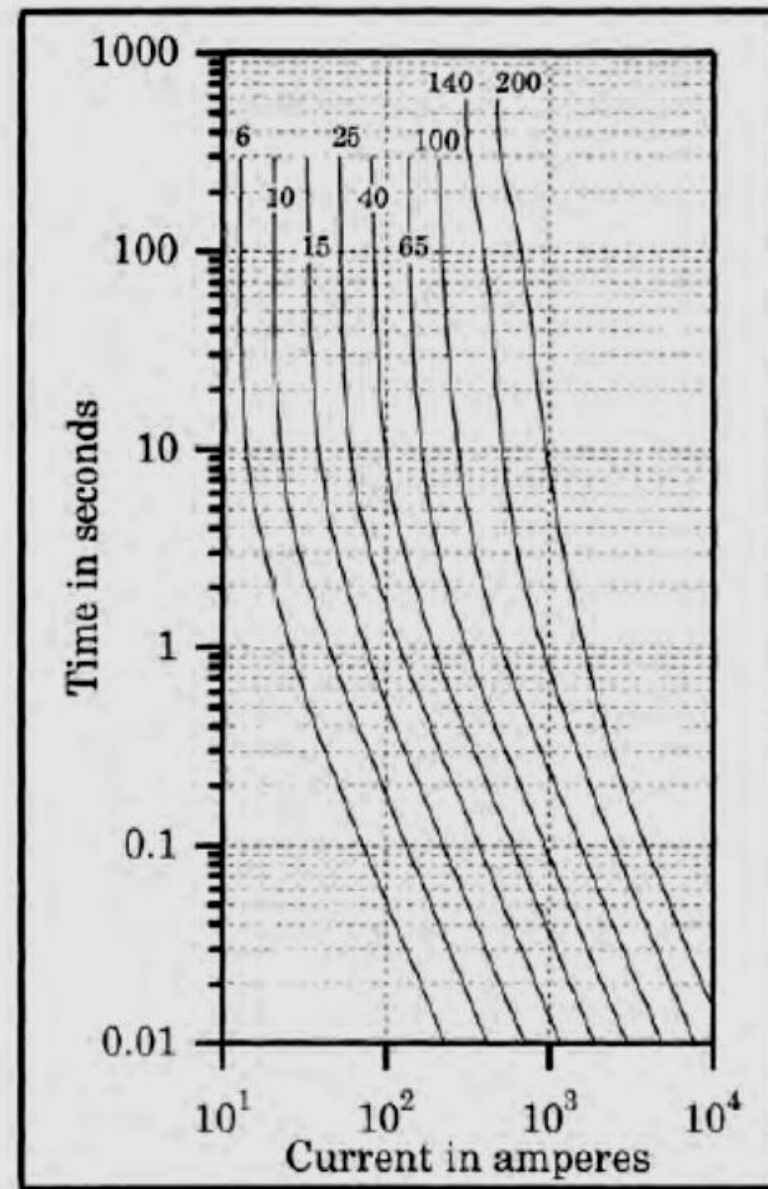
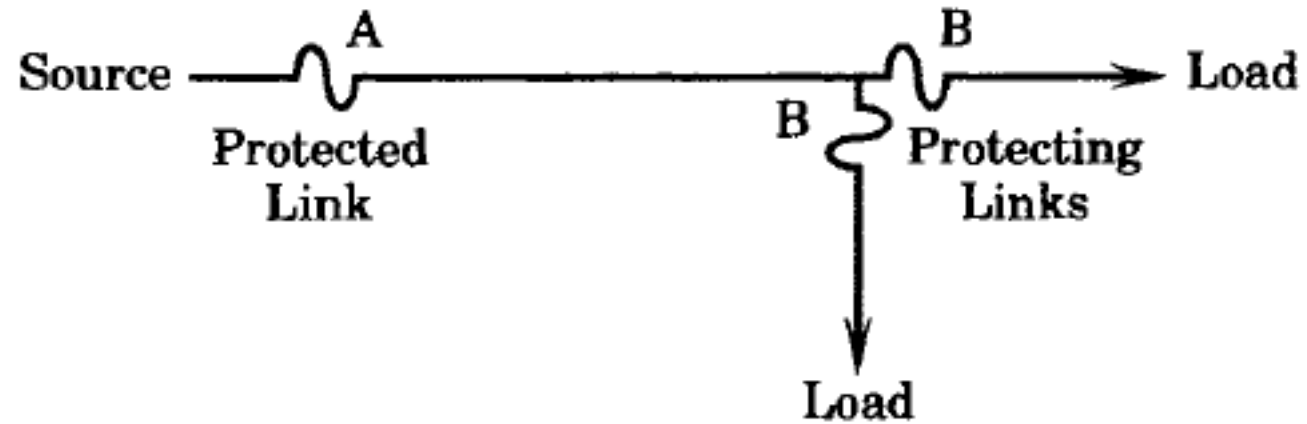

Figure 3.7 The entire set of type K minimum melting time-current fuse characteristics.

Fuse-Fuse Coordination



Manufacturers often provide coordination charts



Fuse-Fuse Coordination



TABLE 3.7 Continuous Current-Carrying Capacity of EEI-NEMA Fuse Links

EEI-NEMA K or T Rating	Continuous Current (amperes)	EEI-NEMA K or T Rating	Continuous Current (amperes)	EEI-NEMA K or T Rating	Continuous Current (amperes)
6	9	20	30	65	95
8	12	25	38	80	120†
10	15	30	45	100	150†
12	18	40	60*	140	190
15	23	50	75*	200	200

* Only when used in a 100 or 200 ampere cutout.

† Only when used in a 200 ampere cutout.

Fuse-Fuse Coordination



Refer to: W. Ruschel, A. Ashley, “**Coordination of Relays, Reclosers, and Sectionalizing Fuses for Overhead Lines in the Oil Patch**”, *IEEE Transactions on Industry Applications*, vol. 25, no. 6, 1989.

EXAMPLE 3.1

Consider the radial distribution line shown in Figure 3.9, where customers are served all along the length of the feeders. Fuse A is the main feeder protection, and Fuses B and C are installed on lateral feeders to limit the outage due to remote faults, for example, for faults beyond B or C.

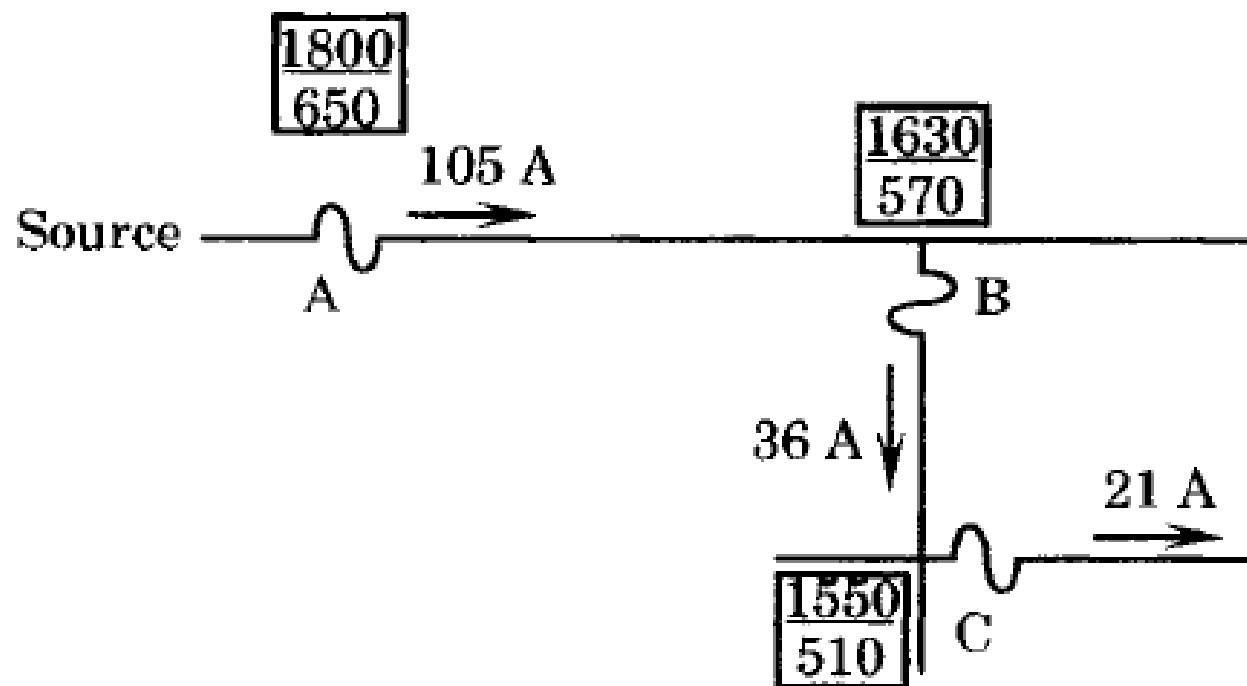

Distribution system fuse data.

The maximum and minimum available fault currents, in amperes, at each location are shown in the boxes. Also shown is the normal load current flowing through each fuse. Check the coordination of the fuses. Select fuse ratings for A, B, and C that will coordinate properly.

Fuse-Fuse Coordination

Solution

As a first trial, let fuse C be a 15T fuse. The load current is 21 A, but the 15T is capable of 23 A, according to Table 3.7. Therefore this fuse is of adequate rating, although there is little room for load growth. From Table 3.6 for T links, we see that the 15T will coordinate with the 25T fuse at location B for currents up to 730 A, but the maximum fault current is 1550 A. Therefore, we select the 30T fuse for location B. The 30T can carry 45 A continuously (OK) and, from Table 3.6, will coordinate with the 15T protecting fuse up to 1700 A. This is a good choice.

The 30T must coordinate with A for fault currents up to 1800 A. To carry the load current at A, we must select the 80T fuse, which can carry 120 A. The 80T will coordinate with the 30T for fault currents up to 5000 A, and this system has only 1800 A available. Thus, a workable solution is 80T at A, 30T at B, and 15T at C. The engineer may wish to allow for a greater load growth at C, depending on the nature of the load served and its likelihood for growth. This would require a larger fuse at C, which will then require that all fuse selections be reconsidered. ■

Fuse-Fuse Coordination- Example 2



A typical 22kV radial distribution system with the topology shown in Figure below. All bus loads are 1 MW with power factor 0.92. For each feeder segment the following values have been considered for resistance and reactance: $R=0.2066$ per unit and $X=0.64876$ per unit.

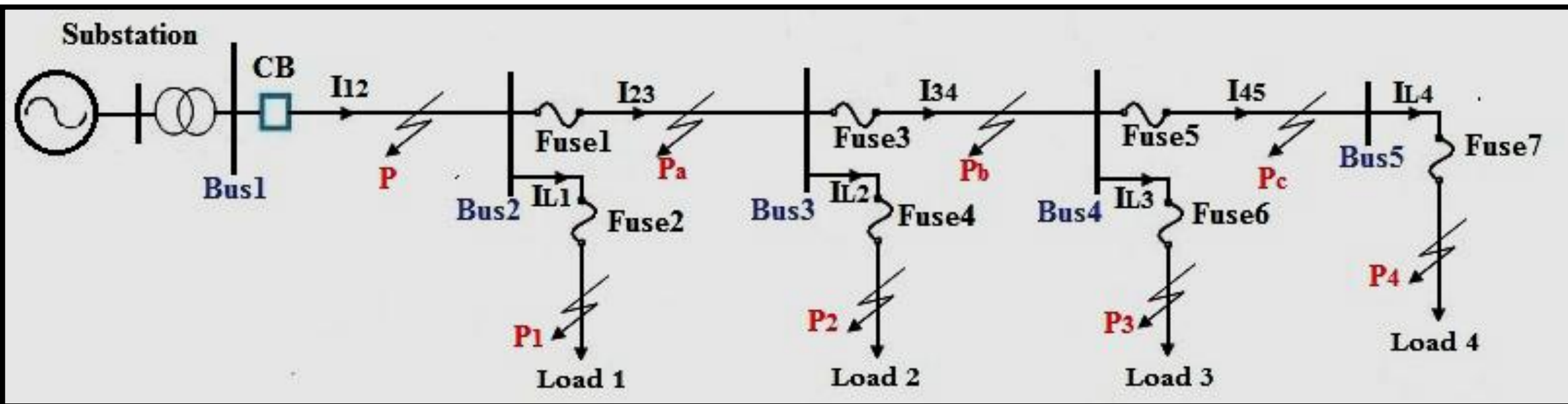

Fuse-Fuse Coordination- Example 2

Results of normal operation and fault analysis

PD	Max. Load Current (A)	Max. Fault Current (kA)	PD Type
CB	120	2.4551	CO-9
Fuse1	90	1.4763	100T
Fuse2	30	1.3117	25T
Fuse3	60	1.0538	65T
Fuse4	30	0.9780	25T
Fuse5	30	0.8236	40T
Fuse6	30	0.7781	25T
Fuse7	30	0.6444	25T

Fuse-Fuse Coordination- Example 2



Basically, there is no any definite protection coordination scheme. The coordination scheme is normally determined according to individual specific topology of a distribution system, as well as various desired behaviors. For a typical distribution network shown in the previous figure the following protection devices pairs Fuse 7-Fuse 5, Fuse 5-Fuse 3, Fuse 3-Fuse 1, Fuse 6-Fuse 3, Fuse 4-Fuse 1, Fuse 2-CB, and Fuse 1-CB will be coordinated as shown in Figure 4-29. It is a general coordination of Fuse-Fuse and Fuse-CB.

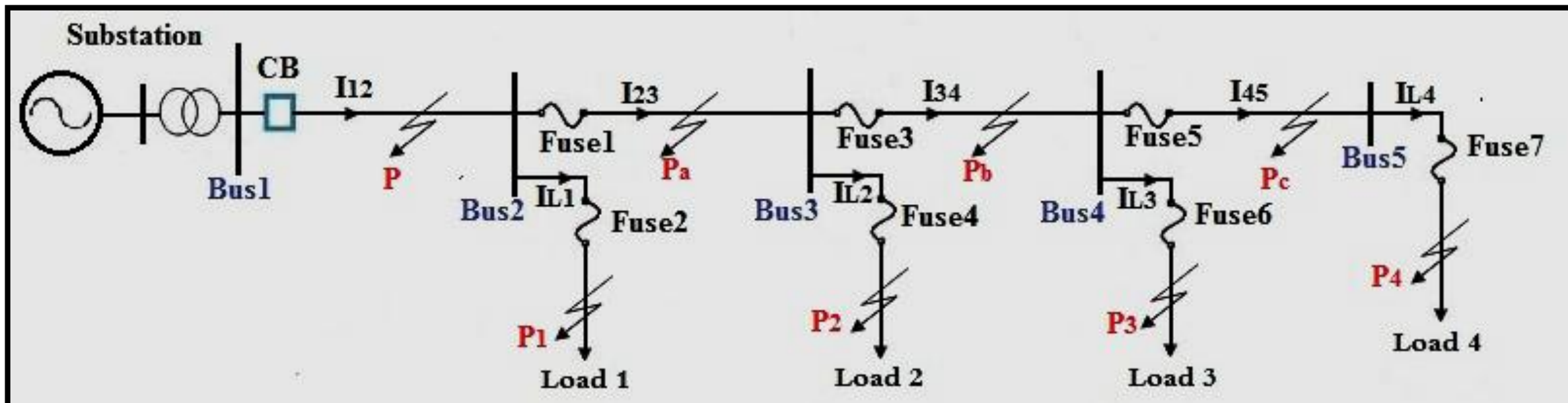

Fuse-Fuse Coordination- Example 2



The philosophy is that protection coordination should be able to confine the disconnected circuit as the smallest area when a fault takes place. This is to obtain the least electricity interruption. For example, when a fault takes place at P3, the Fuse 6 should operate first to clear the fault. However, if fuse 6 fails to operate, Fuse 3 can act as a backup protection later. After that, Fuse 1 also acts as a backup protection of Fuse 3, in case of Fuse 3 fails.

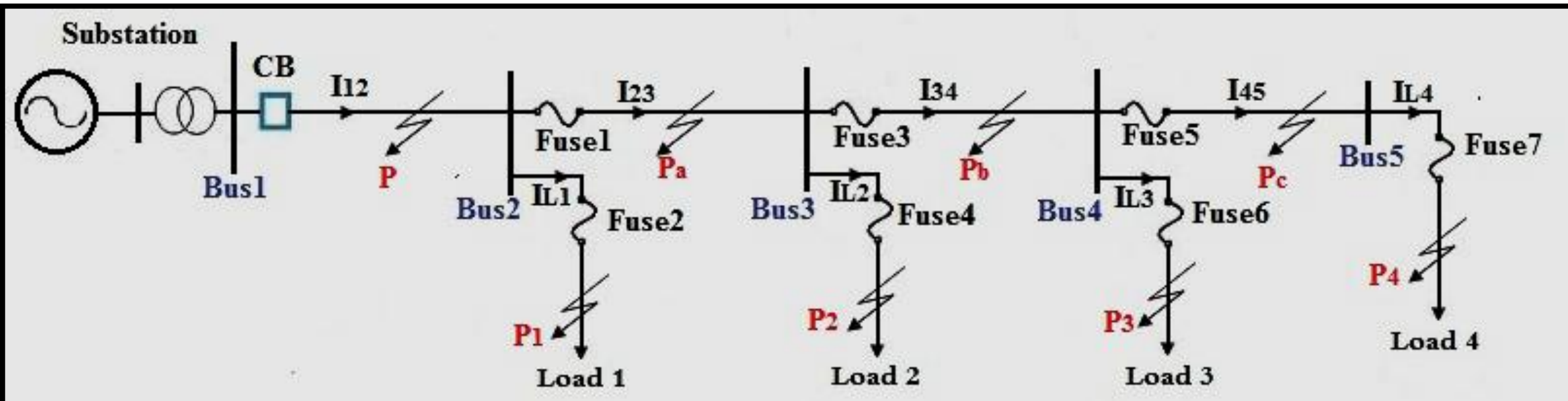

Fuse-Fuse Coordination- Example 2



Regarding the circuit breaker, it will operate lastly as the whole backup protection when both fuses fail in their responsibility. To obtain this sequential operation, the fault current must comply within the minimum and maximum fault current as shown in the next figure. This is called the coordination margin. Therefore, as long as the fault current values are within coordination range, the protection devices are coordinated.

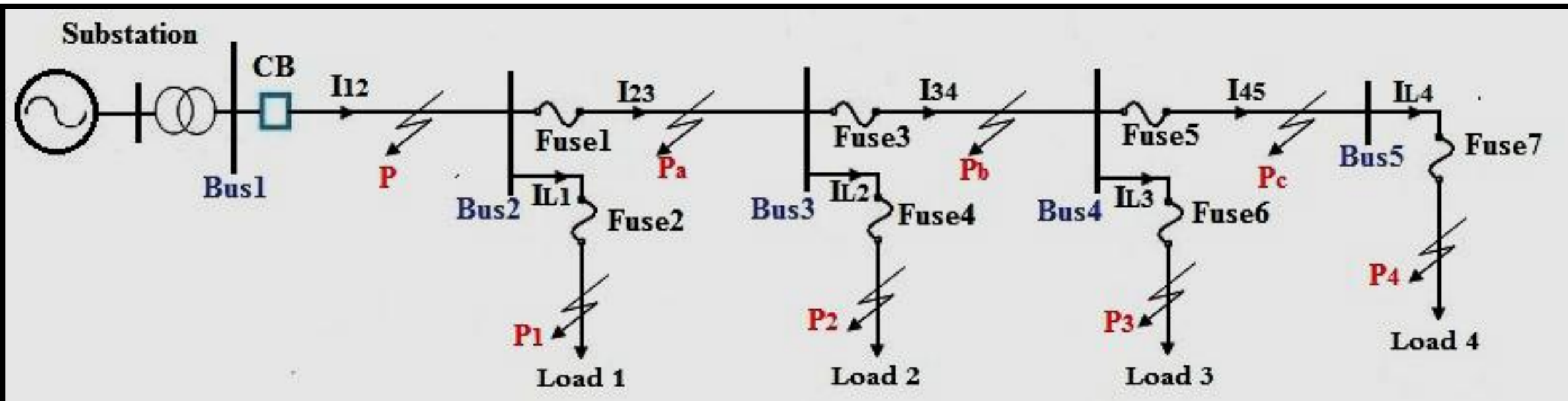

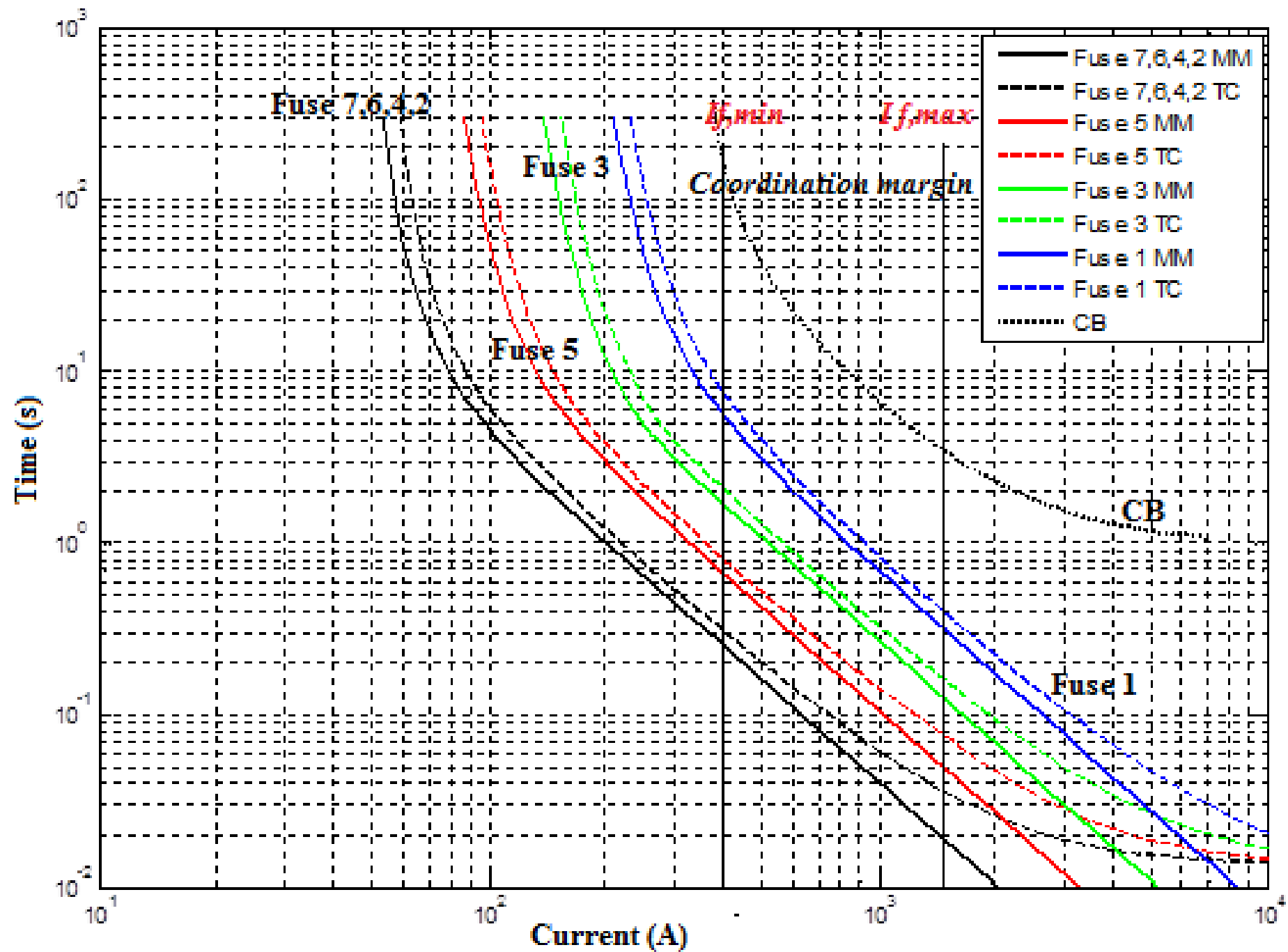

Fuse-Fuse Coordination- Example 2



The system is simulated in normal case to measure the normal currents flow in each branch; after that the proposed network is simulated for three phase fault type at different buses and different locations in order to find the maximum fault current passing through each protection device. Based on those currents, the appropriate CB and fuses are selected. The obtained results are summarized in next table.

Fuse-Fuse Coordination- Example 2

Results of normal operation and fault analysis

PD	Max. Load Current (A)	Max. Fault Current (kA)	PD Type
CB	120	2.4551	CO-9
Fuse1	90	1.4763	100T
Fuse2	30	1.3117	25T
Fuse3	60	1.0538	65T
Fuse4	30	0.9780	25T
Fuse5	30	0.8236	40T
Fuse6	30	0.7781	25T
Fuse7	30	0.6444	25T

Fuse-Fuse Coordination- Example 2



Coordination of the fuses and time-delay over-current relay is shown via the time-current curves.

