

Generation of high voltages

‘Alternating Voltage, Series Resonant Circuit’

Series resonant circuit

- The tuned series resonant h.v. testing circuit arose as a means of overcoming the accidental and unwanted resonance to which the more conventional test sets are more prone.
- If we consider a conventional ‘straight’ test which is testing a capacitor C .

Generation of high voltages

‘Alternating Voltage, Series Resonant Circuit’

- $(r_1 + j\omega L_1)$ represents the impedances of the voltage regulator and the transformer primary.
- $j\omega L$ represents the transformer shunt impedance which is usually large compared with L_1 and L_2 and can normally be neglected.
- $(r_2 + j\omega L_2)$ represents the impedance of the transformer secondary.
- $1/(j\omega C)$ represents the impedance of the load.

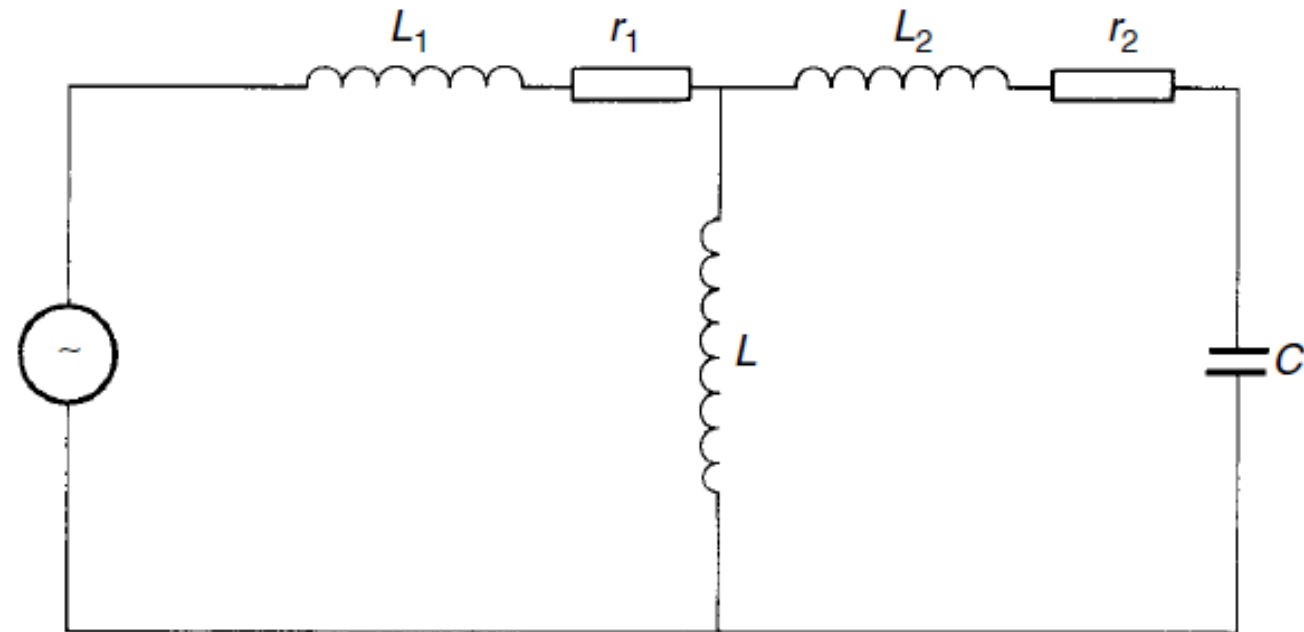

Generation of high voltages

‘Alternating Voltage, Series Resonant Circuit’

- If by chance $\omega(L_1+L_2)=1/\omega C$, accidental resonance occurs. At supply frequency the effect can be extremely dangerous, as the instantaneous voltage application can be of the order of 20 times the intended high voltage.
- Similarly, presence of harmonics due to saturation of iron core of transformer may also result in resonance. Third harmonic frequencies have been found to be quite disastrous.
- With series resonance, the resonance is controlled at fundamental frequency and hence no unwanted resonance occurs.
- The development of series resonance circuit for testing purpose has been very widely welcome by the cable industry as they faced resonance problem with test transformer while testing short lengths of cables.
- In the initial stages, it was difficult to manufacture continuously variable high voltage and high value reactors to be used in the series circuit and therefore, indirect methods to achieve this objective were employed.

Generation of high voltages 'Alternating Voltage, Series Resonant Circuit'

- A continuously variable reactor connected in the low voltage winding of the step up transformer whose secondary is rated for the full test voltage. C_2 represents the load capacitance.
- If N is the transformation ratio and L is the inductance on the low voltage side of the transformer, then it is reflected with N^2L value on the secondary side (load side) of the transformer.
- For certain setting of the reactor, the inductive reactance may equal the capacitive reactance of the circuit, hence resonance will take place.

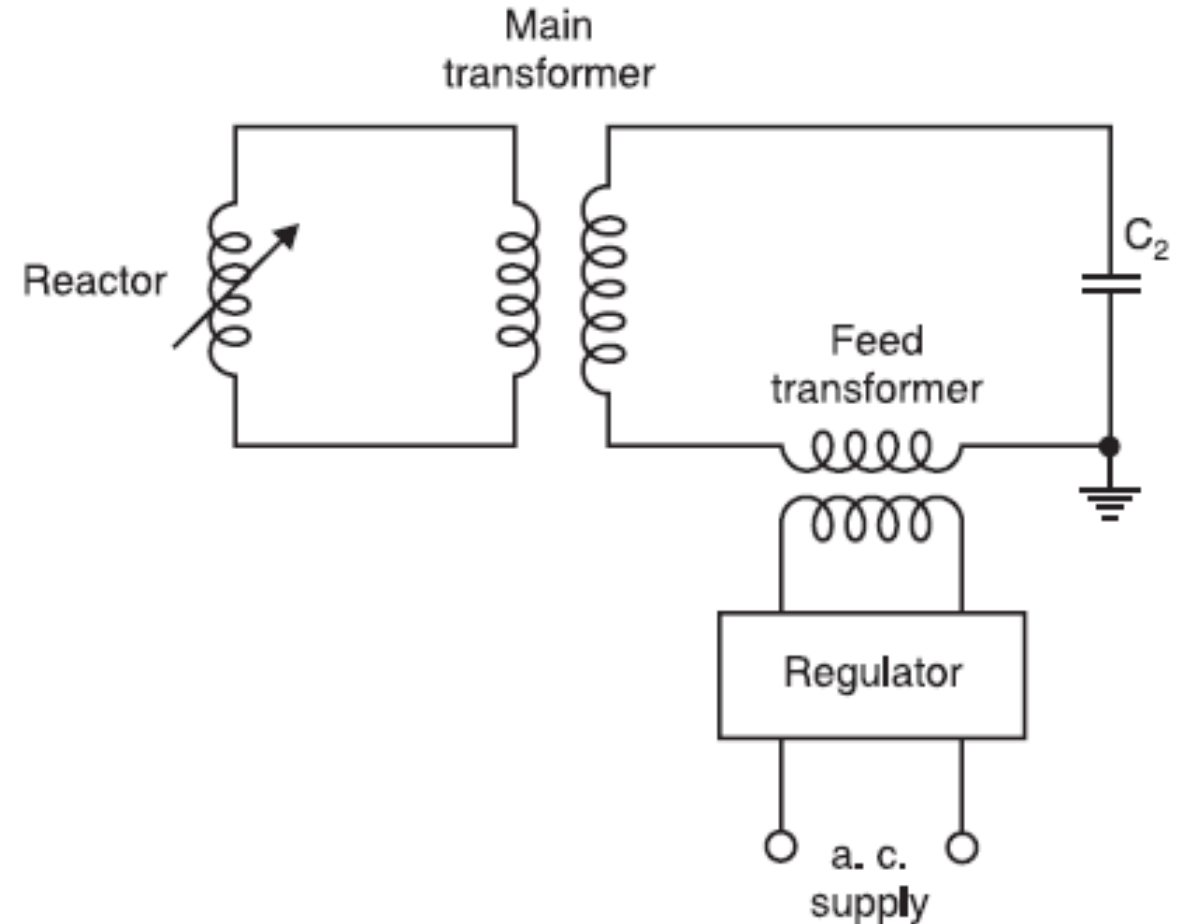

Generation of high voltages

‘Alternating Voltage, Series Resonant Circuit’

- Thus, the reactive power requirement of the supply becomes zero and it has to supply only the losses of the circuit.
- However, the transformer has to carry the full load current on the high voltage side. This is a disadvantage of the method.
- The inductor are designed for high quality factors $Q = \omega L / R$.
- The feed transformer, therefore, injects the losses of the circuit only.

Generation of high voltages

‘Alternating Voltage, Series Resonant Circuit’

- After the resonance condition is achieved, the output voltage can be increased by increasing the input voltage. The feed transformers are rated for nominal current ratings of the reactor.
- Under resonance, the output voltage will be

$$V_0 = \frac{V}{R\omega C_2}$$

where V is the supply voltage.

Generation of high voltages

‘Alternating Voltage, Series Resonant Circuit’

- Since at resonance

$$\omega L' = \frac{1}{\omega C_2} \Rightarrow V_0 = \frac{\omega L'}{R} V = QV$$

where Q is the quality factor of the inductor which usually varies between 40 and 80.

Generation of high voltages

‘Alternating Voltage, Series Resonant Circuit’

- This means that with $Q = 40$, the output voltage is 40 times the supply voltage.
- It also means that the reactive power requirements of the load capacitance in kVA is 40 times the power to be provided by the feed transformer in kW.
- This results in a relatively small power rating for the feed transformer.

Generation of high voltages

‘Alternating Voltage, Series Resonant Circuit’

Example

A 100 kVA 250 V/200 kV feed transformer has resistance and reactance of 1% and 5% respectively. This transformer is used to test a cable at 400 kV at 50 Hz. The cable takes a charging current of 0.5 A at 400 kV. Determine the series inductance required. Assume 1% resistance of the inductor. Also determine input voltage to the transformer. **Neglect dielectric loss of the cable.**

Generation of high voltages

‘Alternating Voltage, Series Resonant Circuit’

The resistance and reactance of the transformer are

$$\frac{1}{100} \times \frac{200^2}{0.1} = 4 \text{ k}\Omega$$

$$\frac{5}{100} \times \frac{200^2}{0.1} = 20 \text{ k}\Omega$$

The resistance of the inductor

$$\frac{1}{100} \times \frac{200^2}{0.1} = 4 \text{ k}\Omega$$

Generation of high voltages 'Alternating Voltage, Series Resonant Circuit'

The capacitive reactance (load)

$$X_C = \frac{400}{0.5} = 800 \text{ k}\Omega$$

For resonance

$$X_L = X_C = 800 \text{ k}\Omega$$

Generation of high voltages 'Alternating Voltage, Series Resonant Circuit'

Inductive reactance of transformer is $20 \text{ K}\Omega$. Therefore, additional inductive reactance required

$$800 - 20 = 780 \text{ k}\Omega$$

The inductance required

$$\frac{780000}{314} = 2484 \text{ H}$$

Generation of high voltages

‘Alternating Voltage, Series Resonant Circuit’

Total resistance of the circuit is

$$8 \text{ k}\Omega$$

Under resonance condition the supply voltage (secondary voltage)

$$= IR = 0.5 \times 8 = 4 \text{ kV}$$

Therefore, primary voltage

$$= 4 \text{ kV} \times \frac{250 \text{ V}}{200 \text{ kV}} = 5 \text{ V}$$

Generation of high voltages 'Alternating Voltage, Tesla Coil'

Tesla coil

- High frequency high voltages are required for rectifier d.c. power supplies. Also, for testing electrical apparatus for switching surges, high frequency high voltage damped oscillations are needed which need high voltage high frequency transformers.
- The advantages of these high frequency transformers are:
 - i. the absence of iron core in transformers and hence saving in cost and size,
 - ii. pure sine wave output,
 - iii. slow build-up of voltage over a few cycles and hence no damage due to switching surges, and
 - iv. uniform distribution of voltage across the winding coils due to subdivision of coil stack into a number of units.

Generation of high voltages 'Alternating Voltage, Tesla Coil'

- The commonly used high frequency resonant transformer is the *Tesla coil*, which is a doubly tuned resonant circuit.
- The primary voltage rating is 10 kV and the secondary may be rated to as high as 500 to 1000 kV.
- The primary is fed from a d.c. or a.c. supply through the condenser C_1 .
- A spark gap G connected across the primary is triggered at the desired voltage V_1 which induces a high self-excitation in the secondary.

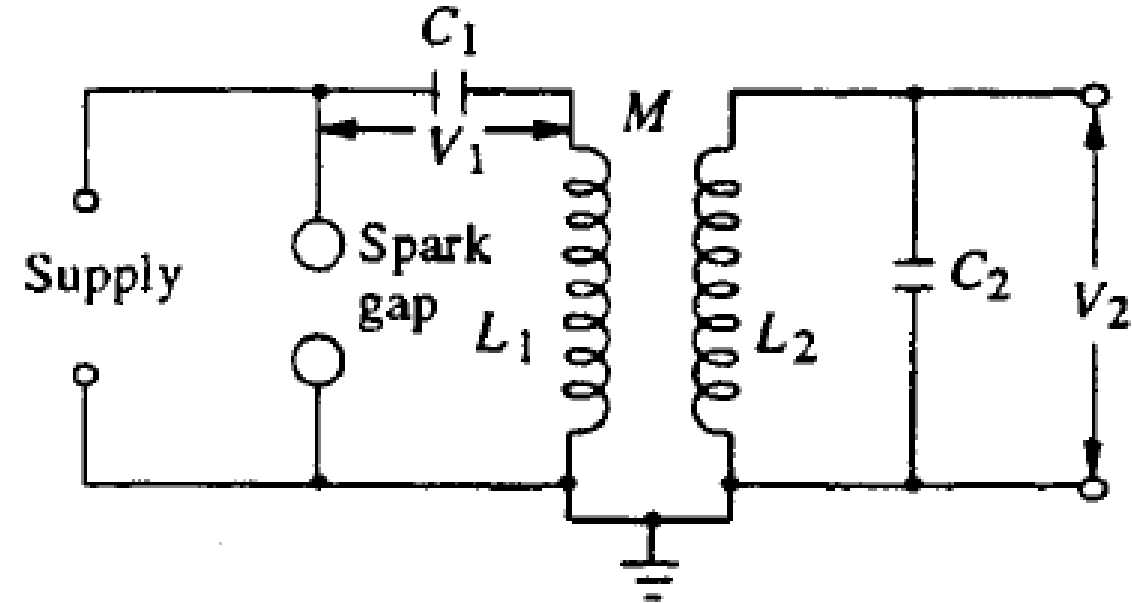

Generation of high voltages 'Alternating Voltage, Tesla Coil'

- The primary and the secondary windings (L_1 and L_2) are wound on an insulated former with no core (air-cored) and are immersed in oil.
- The windings are tuned to a frequency of 10 to 100 kHz by means of the condensers C_1 and C_2 .
- The output voltage V_2 is a function of the parameters L_1 , L_2 , C_1 , C_2 and the mutual inductance M .
- Usually, the winding resistances will be small and contribute only for damping of the oscillations.

Generation of high voltages 'Alternating Voltage, Tesla Coil'

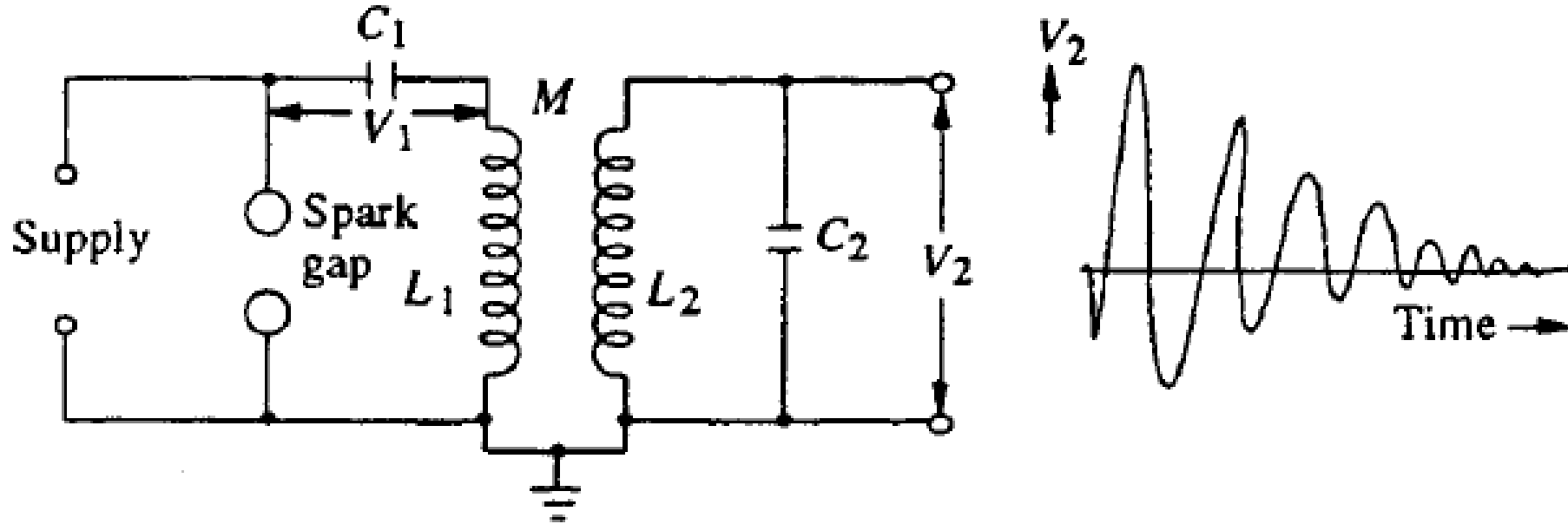

Generation of high voltages 'Alternating Voltage, Tesla Coil'

- The analysis of the output waveform can be done in a simple manner neglecting the winding resistances. Let the condenser C_1 be charged to a voltage V_1 when the spark gap is triggered.
- Let a current i_1 flows through the primary winding L_1 and produce a current i_2 through L_2 and C_2

$$V_1 = \frac{1}{C_1} \int_0^t i_1 dt + L_1 \frac{di_1}{dt} + M \frac{di_2}{dt}$$

$$0 = \frac{1}{C_2} \int_0^t i_2 dt + L_2 \frac{di_2}{dt} + M \frac{di_1}{dt}$$

Generation of high voltages 'Alternating Voltage, Tesla Coil'

- The Laplace transformed equations for the above are,

$$\frac{V_1}{s} = \left(L_1 s + \frac{1}{C_1 s} \right) I_1 + (Ms) I_2$$

$$0 = (Ms) I_1 + \left(L_2 s + \frac{1}{C_2 s} \right) I_2$$

- The output voltage V_2 across the condenser C_2 is

$$V_2 = \left(\frac{1}{C_2 s} \right) I_2$$

Generation of high voltages 'Alternating Voltage, Tesla Coil'

- The solution for V_2 from the above equations will be (taking Laplace inverse)

$$v_2 = \frac{MV_1}{\sigma L_1 L_2 C_2} \frac{1}{\gamma_1^2 - \gamma_2^2} [\cos \gamma_1 t - \cos \gamma_2 t]$$

$$\sigma = \sqrt{1 - K^2}; \quad K = \frac{M}{\sqrt{L_1 L_2}} \quad \gamma_{1,2}^2 = \frac{\omega_1^2 + \omega_2^2}{2} \pm \sqrt{\left(\frac{\omega_1^2 + \omega_2^2}{2}\right)^2 - \omega_1^2 \omega_2^2 (1 - K^2)}$$

$$\omega_1 = \frac{1}{\sqrt{L_1 C_1}} \quad \omega_2 = \frac{1}{\sqrt{L_2 C_2}}$$

Generation of high voltages 'Alternating Voltage, Tesla Coil'

- The peak amplitude of the secondary voltage V_2 can be expressed as,

$$V_2 = V_1 e \sqrt{\frac{L_2}{L_1}}$$

$$e = \frac{2\sqrt{1-\sigma}}{\sqrt{(1+a)^2 - 4\sigma a}} \quad a = \frac{L_2 C_2}{L_1 C_1} = \frac{\omega_2^2}{\omega_1^2}$$

Generation of high voltages 'Alternating Voltage, Tesla Coil'

Example

A Tesla coil has a primary winding rated for 10 kV. If L_1 , L_2 and coefficient of coupling K are 10 mH, 200 mH, and 0.6 respectively. Find the peak value of the output voltage if the capacitance in the primary side is 2.0 μF and that on the secondary side is 1 nF. Neglect the winding resistance. Find also the highest resonant frequency produced with rated voltage applied.

Generation of high voltages 'Alternating Voltage, Tesla Coil'

$$\omega_1 = \frac{1}{\sqrt{L_1 C_1}} = 7.07 \times 10^3 \text{ r/s}$$

$$\omega_2 = \frac{1}{\sqrt{L_2 C_2}} = 7.07 \times 10^4 \text{ r/s}$$

$$\sigma = \sqrt{1 - K^2} = 0.8$$

Generation of high voltages 'Alternating Voltage, Tesla Coil'

- The solution for V_2 from the above equations will be

$$\gamma_1 = \left[\frac{\omega_1^2 + \omega_2^2}{2} + \sqrt{\frac{\omega_1^2 + \omega_2^2}{2} - \omega_1^2 \omega_2^2 (1 - K^2)} \right]^{0.5} = 70.8 \times 10^3 \text{ r/s}$$

$$\gamma_2 = \left[\frac{\omega_1^2 + \omega_2^2}{2} - \sqrt{\frac{\omega_1^2 + \omega_2^2}{2} - \omega_1^2 \omega_2^2 (1 - K^2)} \right]^{0.5} = 5.645 \times 10^3 \text{ r/s}$$

Generation of high voltages 'Alternating Voltage, Tesla Coil'

$$V_2 = \frac{MV_1}{\sigma L_1 L_2 C_1} \frac{1}{\gamma_1^2 - \gamma_2^2} = 33.61 \text{ kV}$$

$$v_2 = V_2 [\cos \gamma_1 t - \cos \gamma_2 t] = 33.61 [\cos(70.83 \times 10^3 t) - \cos(5.645 \times 10^3 t)]$$

$$f_{highest} = \frac{\gamma_1}{2\pi} = 11.27 \text{ kHz}$$