

Basic Components of power systems “Substations”

- The substation is where the voltage is adjusted, circuits are switched, system is monitored, and equipment is protected. A typical substation includes:
 - Transformers
 - Switching equipment
 - Protection equipment
 - Measuring devices
 - Control systems

Basic Components of power systems “Substations”

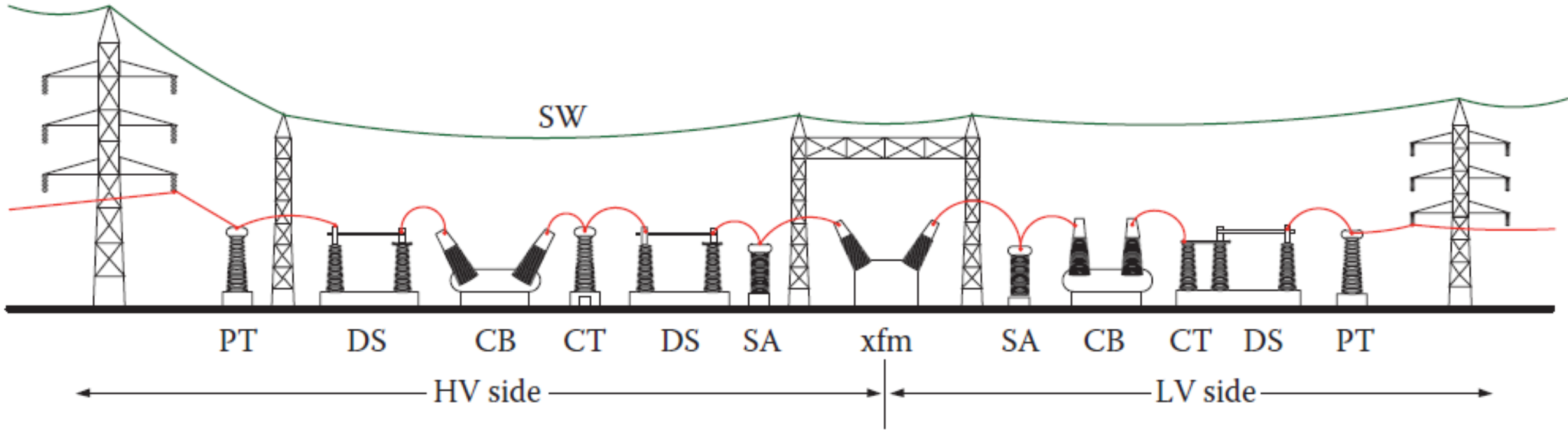

Main parts of substation

Basic Components of power systems “Substations”

- The substation steps up or steps down the voltage of the incoming power.
- The incoming line reaches the substation, and its voltage is measured by a potential transformer (PT).
- Next, a disconnecting switch (DS) is placed to isolate a section of the substation when needed.
- A circuit breaker (CB) is connected to the DS to open the circuit when faults occur.
- A current transformer (CT) then measures the line current of the high-voltage side.

Basic Components of power systems “Substations”

- Another DS is placed after the CB. When the CB is being serviced, the two adjacent DSs are opened to isolate the CB from any energized part.
- Before going to the transformer (xfm), a surge arrester (SA) is installed. This device is designed to dissipate any lightning or surge transients from reaching and damaging the transformer.
- The transformer steps down the voltage to lower levels. The low-voltage side of the transformer has another surge arrester to protect the xfm from the surges or lightning strikes that may come from the low-voltage side.
- Next are lower-voltage CBs, CTs, DSs, and PTs.

Basic Components of power systems “Substations”

Basic components of protection system:

- **Voltage and current transformers** (VTs and CTs):
 - Measure the voltage and currents
 - Step down the voltage and currents from the high level to convenient level for relays to deal with
- Protective relays
 - Sense the faults
 - Initiate a trip signal to the circuit breaker
- Circuit breakers (CBs)
 - Receive the trip signal from relay
 - Breaks the faulted circuit for a few cycles until the fault is cleared
- DC batteries
 - Power source for relays and CBs

Basic Components of power systems “Substations”

Main performance criterion of any protection system:

- Selectivity
- Sensitivity
- Speed
- Stability and security
- Reliability

Basic Components of power systems “Substations”

The philosophies of unit and non unit protection:

- Unit protection:
 - Look at a specific part of the system
 - Only operates for faults within the protected zone whilst remaining inoperative for external faults
 - It compares two or more measurement quantities such as current
 - Example: Differential protection
- Non-Unit protection
 - Look at the whole system
 - Only operates if tripping criterion is satisfied ($I_F > I_{\text{setting}}$)
 - Example: Overcurrent protection

Basic Components of power systems

“Substations, potential transformer”

- To measure the voltage of the line V_1 , we can use the capacitor divider.
- If we make $C_2 \gg C_1$, the voltage across C_2 will be much smaller than transmission line voltage, allowing us to use low-voltage voltmeter.
- In this case, the current through the capacitors is:

$$I = V_1 \left[2\pi f \left(\frac{C_1 C_2}{C_1 + C_2} \right) \right] = V_2 (2\pi f C_2)$$

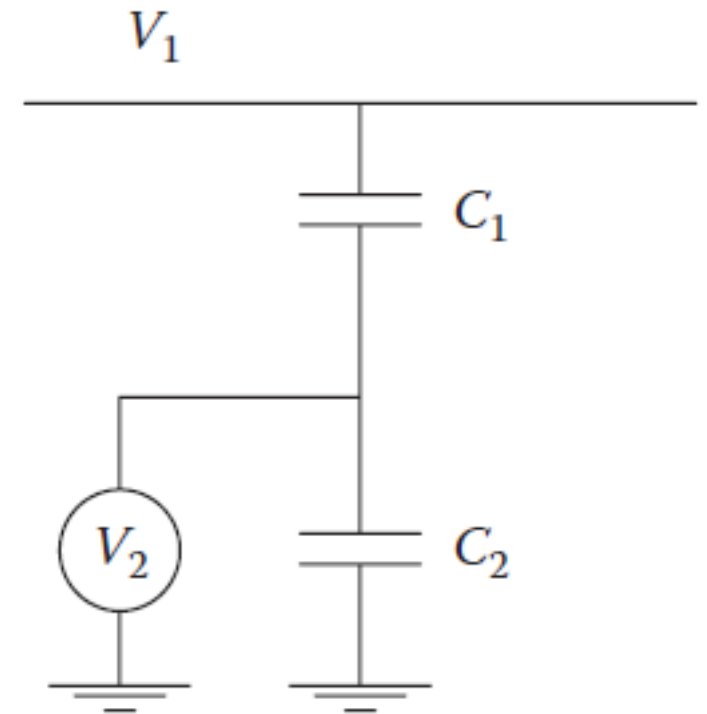

Capacitor voltage transformer

Basic Components of power systems

“Substations, potential transformer”

- By measuring the low-voltage V_2 , we can compute the high-voltage V_1 of the line.

$$V_1 = V_2 \left(1 + \frac{C_2}{C_1} \right)$$

- V_2 is usually 10-12 kV
- V_s is 110 V to facilitate standardization of the secondary equipment.

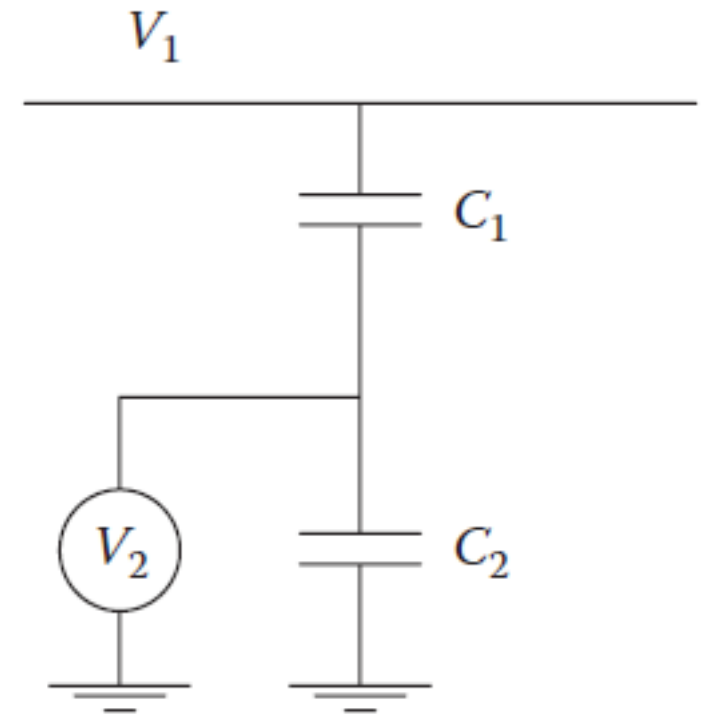

Capacitor voltage transformer

Basic Components of power systems

“Substations, potential transformer”

- The values of C_1 and C_2 within the capacitor divider are often obtained by a tapping on a capacitor bushing (C_1 typically 2000 pF)
- To avoid error in the measurement of V_1 due to the considerable impedance of the capacitor divider, inductance L is included to resonate with the effective source capacitance $C = C_1 + C_2$.
- L is designed so that at 50 Hz, $\omega L = 1/\omega C$

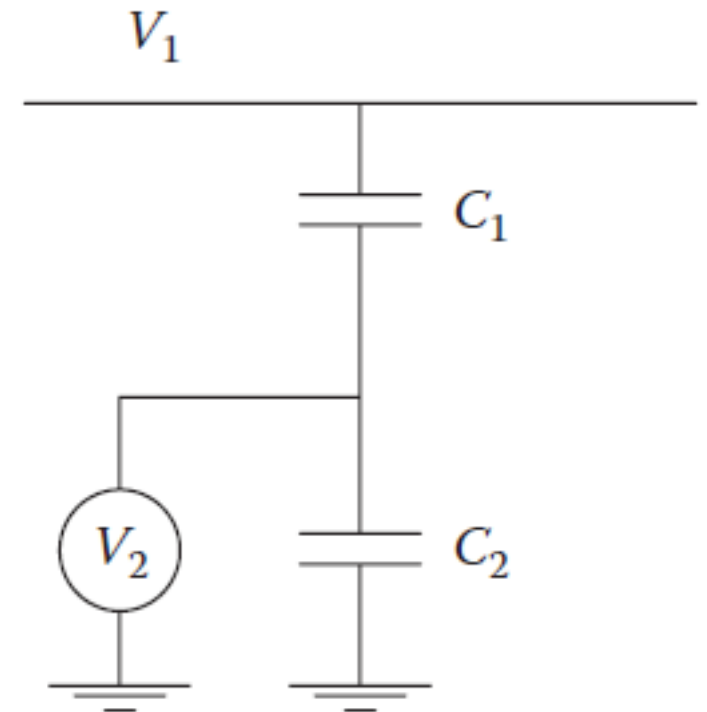

Capacitor voltage transformer

Basic Components of power systems “Substations, potential transformer”



Potential
transformer

Basic Components of power systems

“Substations, potential transformer”

Example

Design a capacitor voltage transformer to measure the voltage of 289 kV line to ground.

Note: In your design select the capacitors that limit the current through them to say 1 A. Also, select the voltage V_2 to be 200 V.

Basic Components of power systems

“Substations, potential transformer”

$$x_{c2} = \frac{V_2}{I} = \frac{200}{1} = 200 \Omega$$

$$C_2 = \frac{1}{\omega x_{c2}} = \frac{1}{2\pi \times 60 \times 200} = 13.26 \mu\text{f}$$

$$V_1 = V_2 \left(1 + \frac{C_2}{C_1} \right)$$

$$289 \times 10^3 = 200 \left(1 + \frac{13.26 \times 10^{-6}}{C_1} \right)$$

$$C_1 = 9.18 \text{ nF}$$

Basic Components of power systems

“Substations, potential transformer”

Example

A CVT is used to measure a 400 kV, 50 Hz transmission line voltage. The voltage is scaled down to 10 kV via the capacitors. The voltage drop across the equivalent capacitance of the CVT is eliminated using an inductor with a transformer.

- Calculate the capacitors of the CVT to measure the line voltage such that the current through is limited to 1 A.
- If the inductor transformer turns ratio 100:1, calculate the value of the inductor.

Basic Components of power systems

“Substations, current transformer”

Solution

$$X_{C_2} = \frac{V_2}{I} = \frac{10000}{1} = 10000 \Omega$$

$$\frac{1}{\omega C_2} = 10000 \Rightarrow C_2 = 318.3 \text{ nF}$$

$$\frac{V_2}{V_p} = \frac{C_1}{C_1 + C_2} \Rightarrow \frac{V_p}{V_2} = 1 + \frac{C_2}{C_1} \Rightarrow \frac{400/\sqrt{3}}{10} = 1 + \frac{318.3 \times 10^{-9}}{C_1} \Rightarrow C_2 = 14.4 \text{ nF}$$

Basic Components of power systems

“Substations, current transformer”

Solution

$$X_{C_{eq}} = X_{L_{eq}}$$

$$\frac{1}{\omega(C_1 + C_2)} = \omega L' \Rightarrow L' = \frac{1}{\omega^2(C_1 + C_2)} = 30.45 \text{ H}$$

$$L = \frac{L'}{n^2} = \frac{30.45}{10000} \Rightarrow L = 3 \text{ mH}$$

Basic Components of power systems

“Substations, current transformer”

- The CT is a special type of transformer
- The primary winding is replaced by the conductor whose current is to be measured.
- The secondary winding is wrapped around an iron core and has hundreds or thousands of turns.
- The secondary windings are shorted by an ammeter.

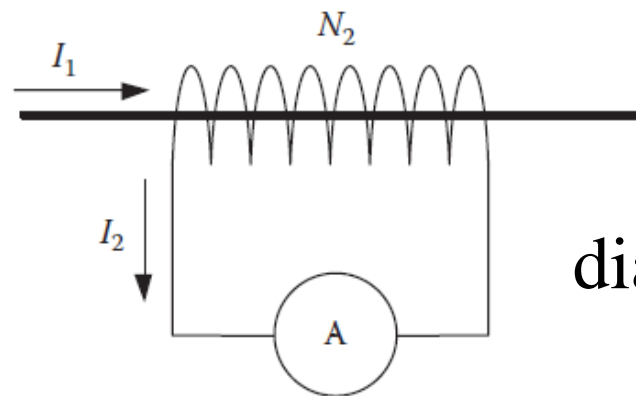

Circuit diagram of CT

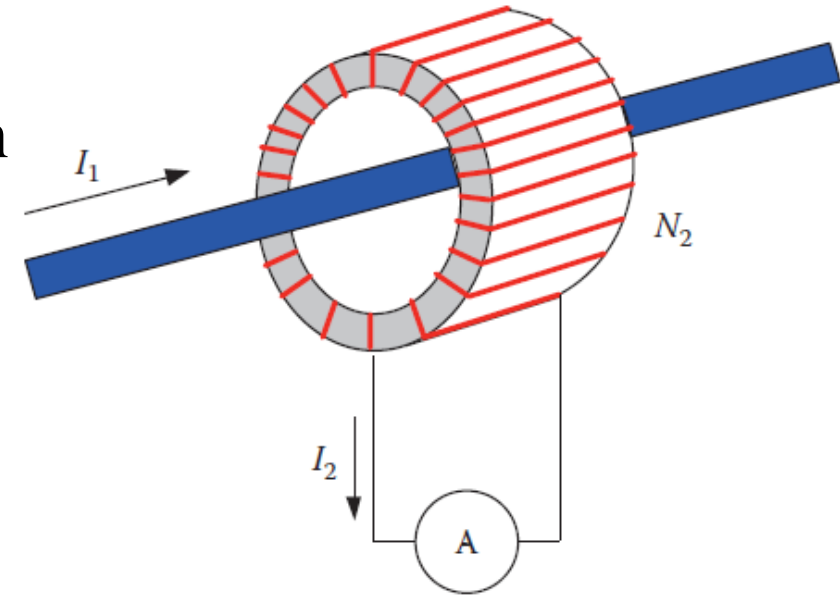

Main parts of CT

Basic Components of power systems “Substations, current transformer”



Current
transformer

Basic Components of power systems

“Substations, current transformer”

- If we ignore the leakage flux, we can use the ampere-turn theory to estimate the secondary current I_2

$$I_1 N_1 = I_2 N_2$$

where

I_1 is the current in the transmission line conductor

I_2 is the current in the secondary winding of the CT

N_1 is the number of turns of the transmission line conductor, which is 1

N_2 is the number of turns of the secondary windings

Basic Components of power systems

“Substations, current transformer”

- Hence, if we measure the current I_2 , we can compute the line current I_1 :
- The rated secondary current I_2 is standardized at 1–5 A.
- The CT must have its secondary windings shorted. This is done by the ammeter connected between its terminals or connecting a heavy load (burden) across its secondary terminals.
- If the secondary winding is accidentally opened, the CT will be damaged. This is because the voltage per turn ratio is almost constant in the primary and secondary windings

$$V_2 = N_2 V_1$$

- Because N_2 and V_1 are high values, V_2 is extremely high and will cause insulation failures and arcing to force the current to pass through the secondary windings.

Basic Components of power systems

“Substations, current transformer”

Equivalent circuit of CT

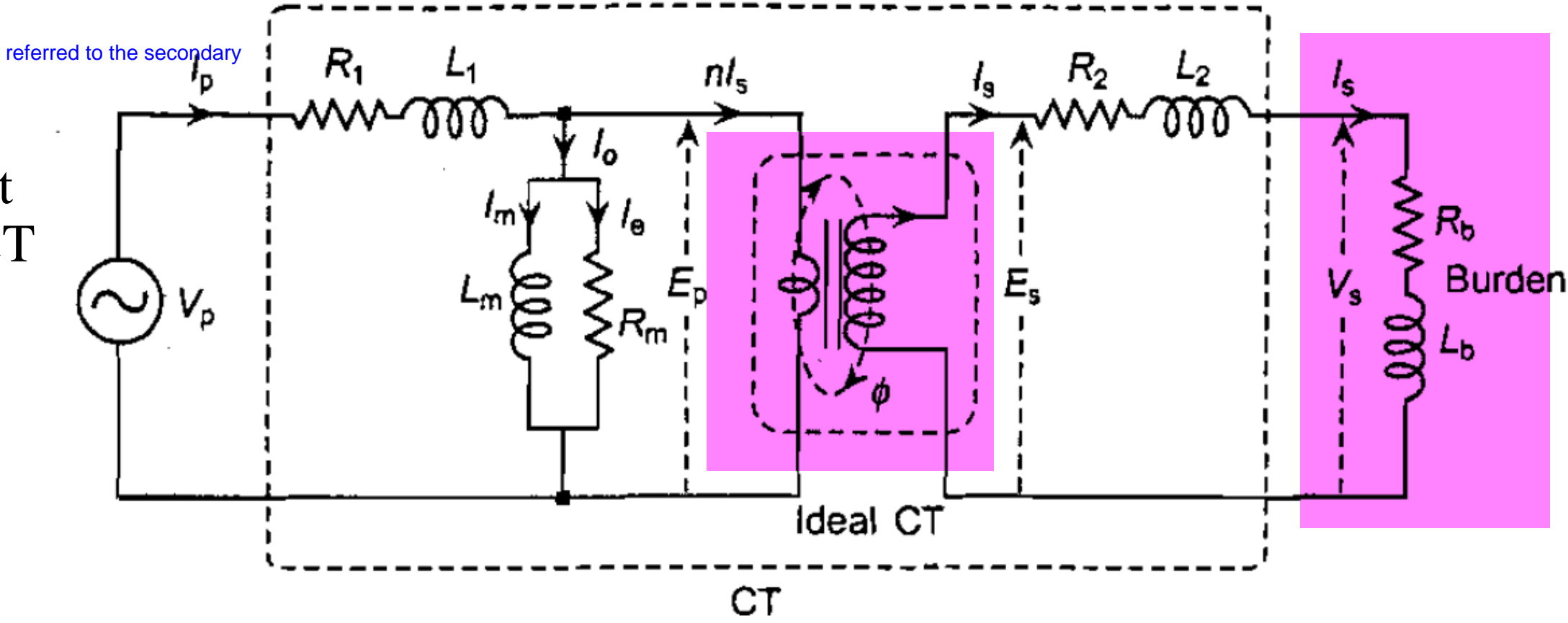

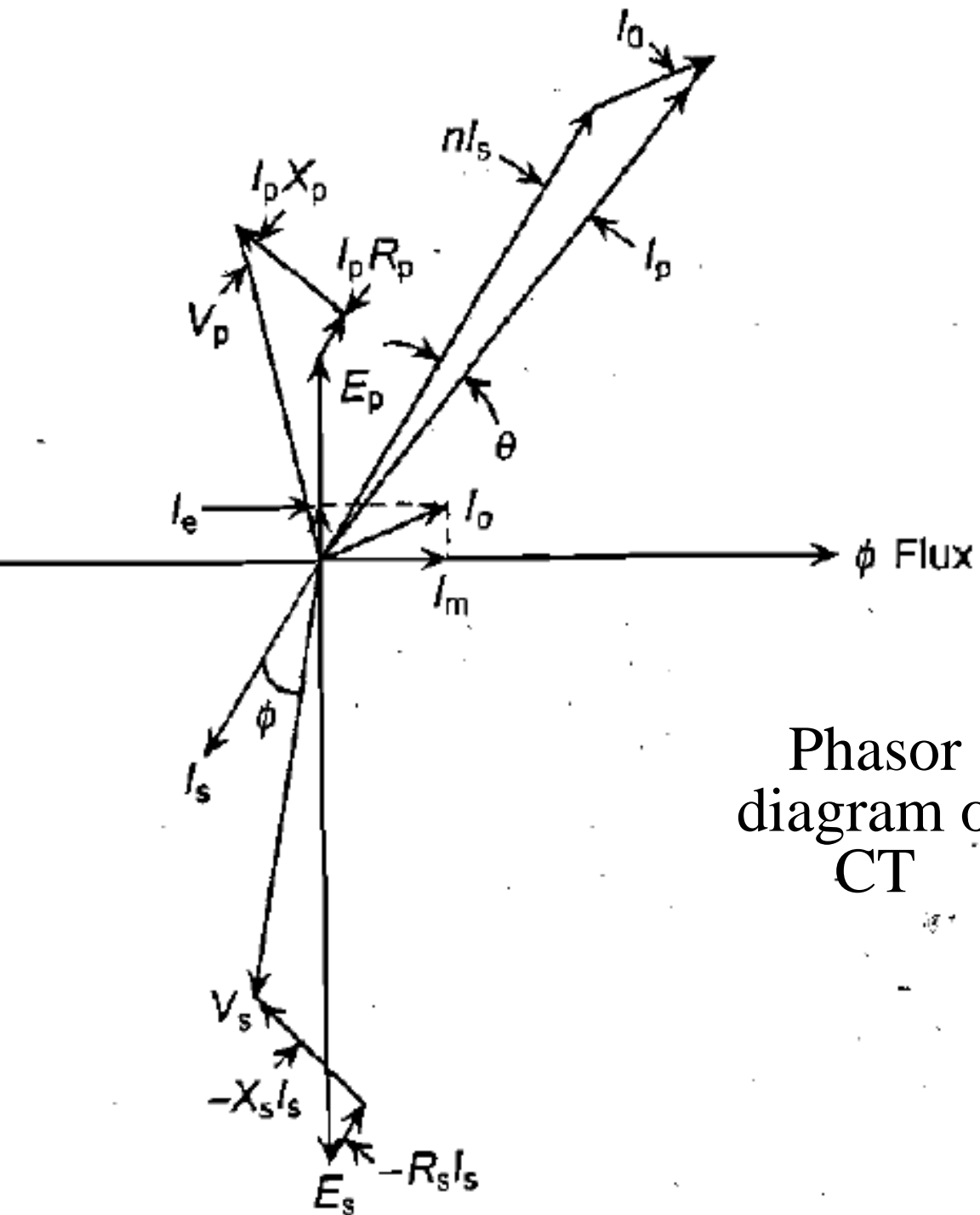

Phasor
diagram of
CT

- θ = Phase angle error
- ϕ = Phase angle of burden
- n = Turns ratio
- I_m = Magnetizing component
- I_e = Iron loss component
- I_o = Excitation
- I_p = Primary current
- I_s = Secondary current
- E_p = Primary induced voltage
- V_p = Primary terminal voltage
- E_s = Secondary induced voltage
- V_s = Secondary terminal voltage

Basic Components of power systems

“Substations, current transformer”

- The current I_o is the source of error in the CT, which can be resolved into two components:
 - Direct component, I_d which is in phase with I_s and responsible for magnitude errors
 - Quadrature component, I_q which is quadrature with I_s and responsible for phase errors
- The errors can be reduced by using an inductive burden which increases the burden angle and ultimately makes I_p in phase with nI_s , thus reducing the phase error
- The magnitude error can be corrected by reducing the number of secondary turns

Basic Components of power systems

“Substations, current transformer”

- CT measurement errors:

- Ratio error: Relative difference between the rms values of nI_s and I_p

$$\text{Ratio error} = \frac{nI_s - I_p}{I_p},$$

- Phase error: Angular difference between nI_s and I_p

$$\text{Phase error} = \text{angle}(nI_s / I_p),$$

Basic Components of power systems

“Substations, current transformer”

- The fault current has two components
 - DC offset current (depends on the X/R ration of the system impedance)
 - Symmetrical steady state fault current
- High value of primary current due to the DC offset cause the CT flux to saturate. I_s collapses during the saturation periods to near zero values
- The solution is to increase the cross-section area of the core, but the size and cost of CT will increase as well as.

Basic Components of power systems

“Substations, current transformer”

- Influence of X/R ratio on CT saturation:
 - The fault current on the primary side of the CT can be described as:

$$i_p(t) = I_p \left(e^{-(\omega R/X)t} - \cos(\omega t) \right),$$

where

ω is the source radian frequency,

R and X are the system resistance and reactance under fault condition.

Basic Components of power systems

“Substations, current transformer”

- The voltage at the primary side of the CT is calculated as:

$$v_p(t) = \frac{R_p}{n^2} I_p \left(e^{-(\omega R/X)t} - \cos(\omega t) \right) = \frac{d\phi}{dt}, \quad \phi : \text{CT core flux}$$

where n is the CT ratio, R_b is a secondary burden

Solving for the flux, we get:

$$\phi(t) = \frac{R_p I_p}{n^2 \omega} \frac{X}{R} \left(1 - e^{-(\omega R/X)t} \right) - \frac{R_p I_p}{n^2 \omega} \sin(\omega t)$$

The maximum flux of CT core is given by:

$$\phi_{\max} = \frac{R_p I_p}{n^2 \omega} \left[\frac{X}{R} + 1 \right]$$

Basic Components of power systems

“Substations, current transformer”

Example

A 600:1 CT is designed to be used with a secondary burden of 3 Ω . The core is constructed from transformer steel which is normally operated at a maximum flux density of 1.2 T. The cross-sectional area of the CT core is 90 cm². If the system X/R ratio is 12, calculate the maximum fault current that may be transformed by the CT without a risk of going into saturation?

Basic Components of power systems “Substations, current transformer”

Solution

$$\phi_{\max} = \frac{R_p I_p}{n^2 \omega} [(X/R) + 1] \Rightarrow I_p = \frac{n^2 \omega \phi_{\max}}{R_p [(X/R) + 1]}$$

$$I_p = \frac{600^2 (2\pi \times 50) (1.2 \times 90 \times 10^{-4})}{3[12 + 1]} = 31.32 \text{ kA}$$

Basic Components of power systems

“Substations, differential protection”

- Under normal operating or external fault conditions, the relay does not trip and the protected zone is healthy.

$$I_1 = I_2$$

$$I_{s1} = I_{s2}$$

$$I_R = I_{s1} - I_{s2} = 0$$

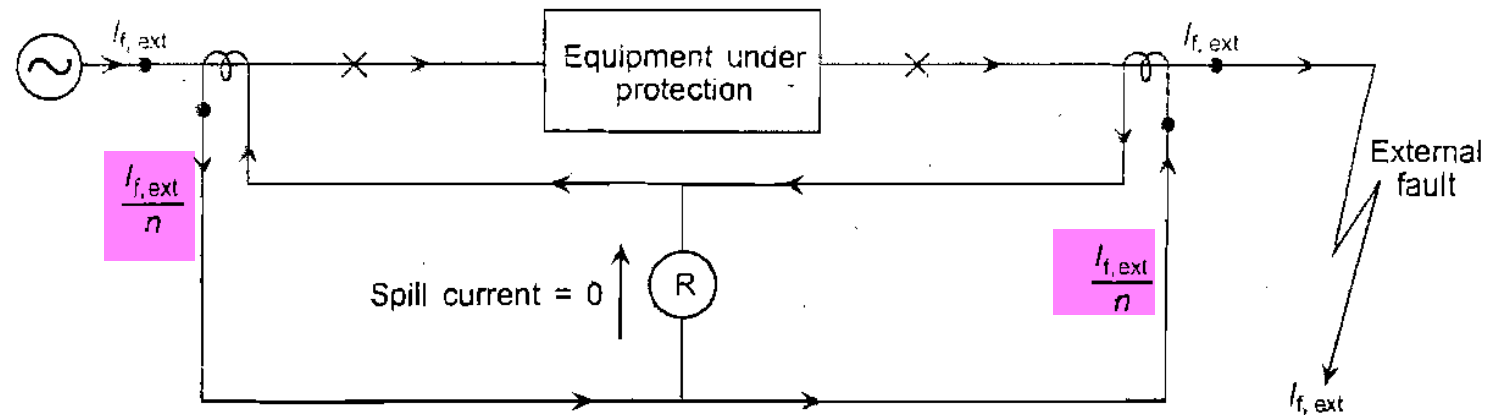

Basic Components of power systems

“Substations, differential protection”

- Under internal fault conditions, the relay will trip and the protected zone is faulty.

$$I_1 = I_2 + I_{f,int}$$

$$I_{s1} = I_{s2} + \frac{I_{f,int}}{N}$$

$$I_R = \frac{I_{f,int}}{N}$$

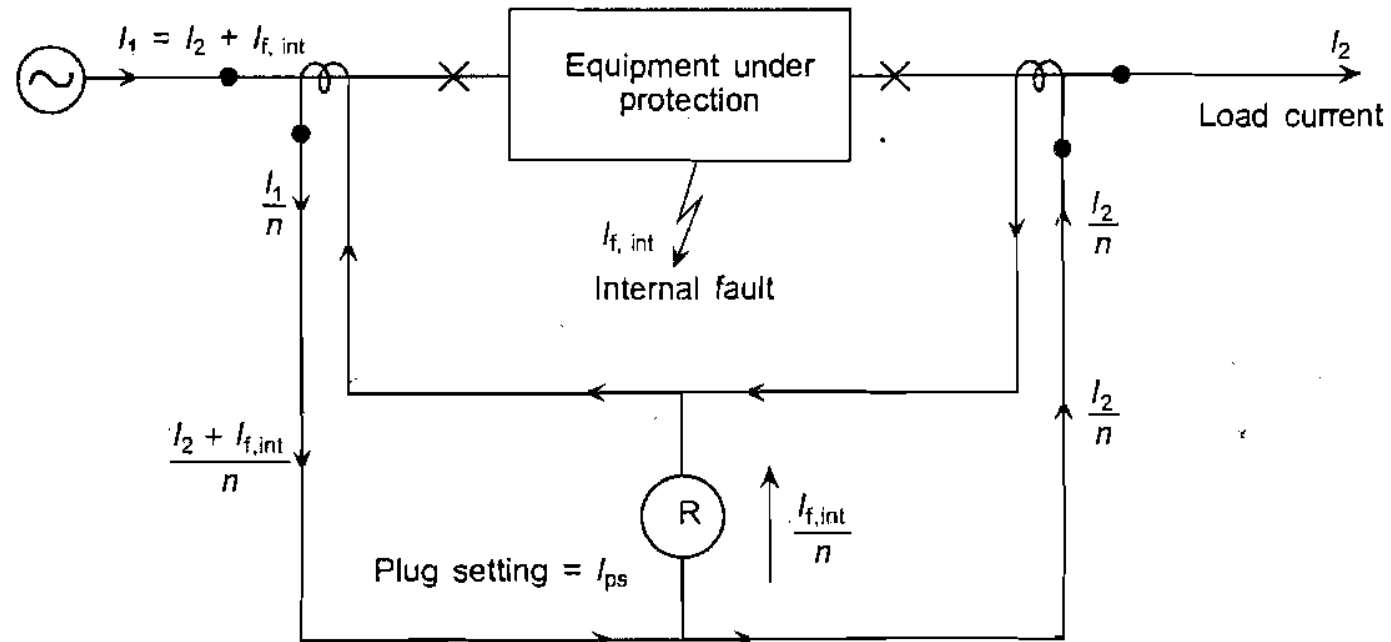

Basic Components of power systems

“Substations, differential protection”

- In ideal situation:
 - CTs are identical ($R_{s1} = R_{s2}$)
 - Wiring resistances are equal ($R_{w1} = R_{w2}$)
- In reality:
 - CTs may not be identical ($R_{s1} \neq R_{s2}$)
 - Wiring resistances may not be equal ($R_{w1} \neq R_{w2}$)
 - There will be a spill current in the differential relay which leads to unwanted operation of the relay under healthy and external fault conditions.
 - The relay must be desensitized.

Basic Components of power systems

“Substations, high impedance differential protection”

- The CT saturation causes an increase in relay spill current, which can be much higher than the steady state spill current if there are differences in excitation characteristics or there are unequal burdens.
- Transient instability is overcome by the application of high impedance differential protection.
 - I_s : relay nominal setting current
 - R_R : stabilizing resistor
 - R_w : wiring resistor
 - R_s : CT winding resistor
 - R_c : relay coil resistor
 - X_m : magnetizing reactance
 - I_f : primary fault current

Basic Components of power systems

“Substations, high impedance differential protection”

- If CT1 is saturated: $V_s = (R_{s1} + R_{w1}) \frac{I_f}{N}$

- If CT2 is saturated: $V_s = (R_{s2} + R_{w2}) \frac{I_f}{N}$

- To prevent relay operation:

$$\frac{V_s}{R_c + R_R} < I_s$$

Basic Components of power systems “Substations, high impedance differential protection”

Example

$$N = 1500:1,$$

$$R_{w1} = 1.4 \, \Omega, R_{w2} = 2.5 \, \Omega$$

$$R_{s1} = 1.8 \, \Omega, R_{s2} = 1.2 \, \Omega$$

$$R_c = 1.5 \, \Omega$$

$$I_f = 45 \, \text{kA}$$

$$I_s = 0.7 \, \text{A}$$

Find the minimum value of stabilizing resistor? The available resistances are from 100 ohm to 300 ohm in steps of 10 ohm

Basic Components of power systems

“Substations, differential protection of transformer”

- Transformer winding connection and vector diagrams
 - Yd 11
 - Dy 5
 - Dy 1
 - Yd 1
 - Dy 7
- CT arrangement must compensate for the phase shift between primary and secondary voltages and currents.
- This scheme must be insensitive to external earth faults

Basic Components of power systems

“Substations, differential protection of transformer”

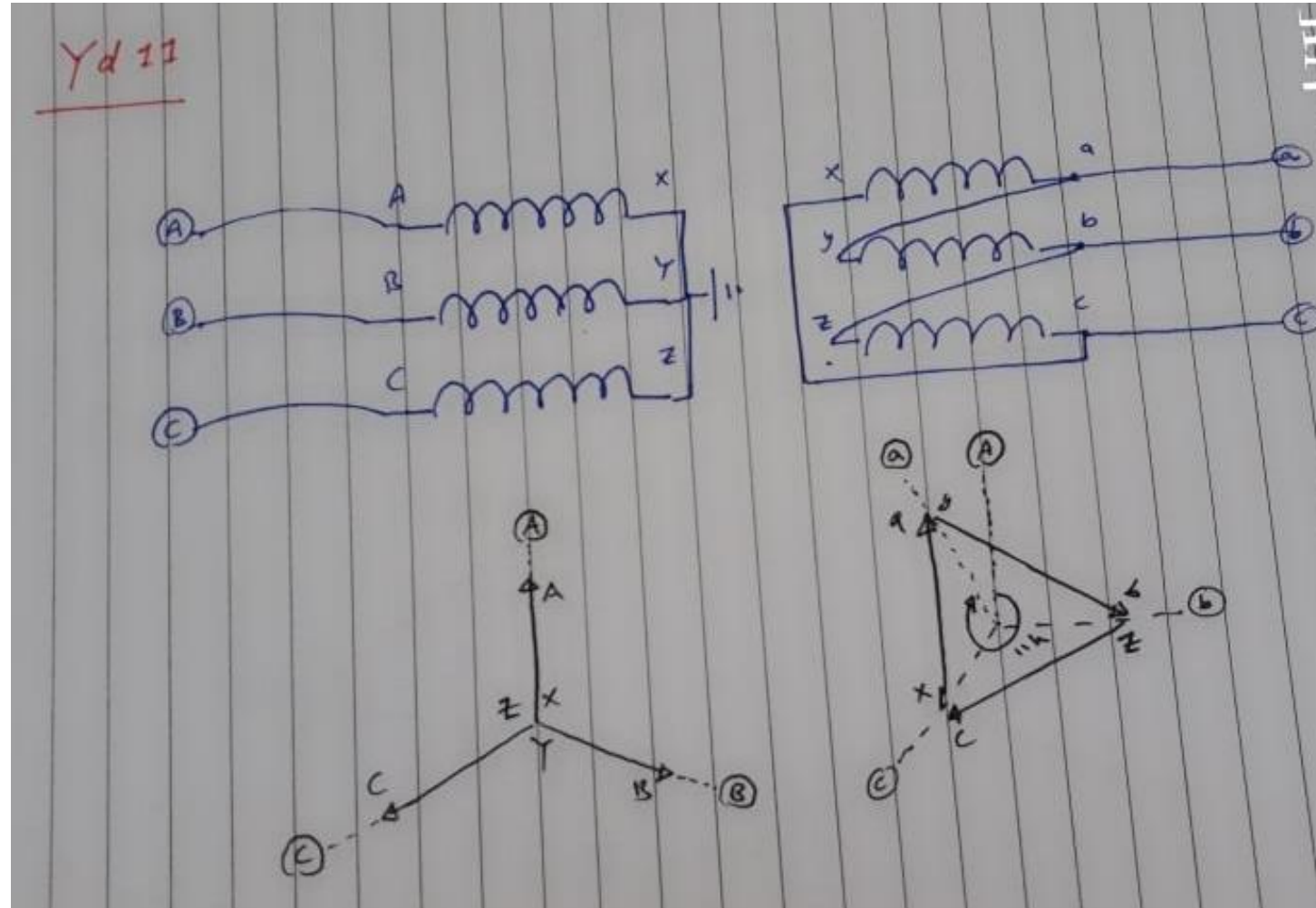

Basic Components of power systems

“Substations, differential protection of transformer”

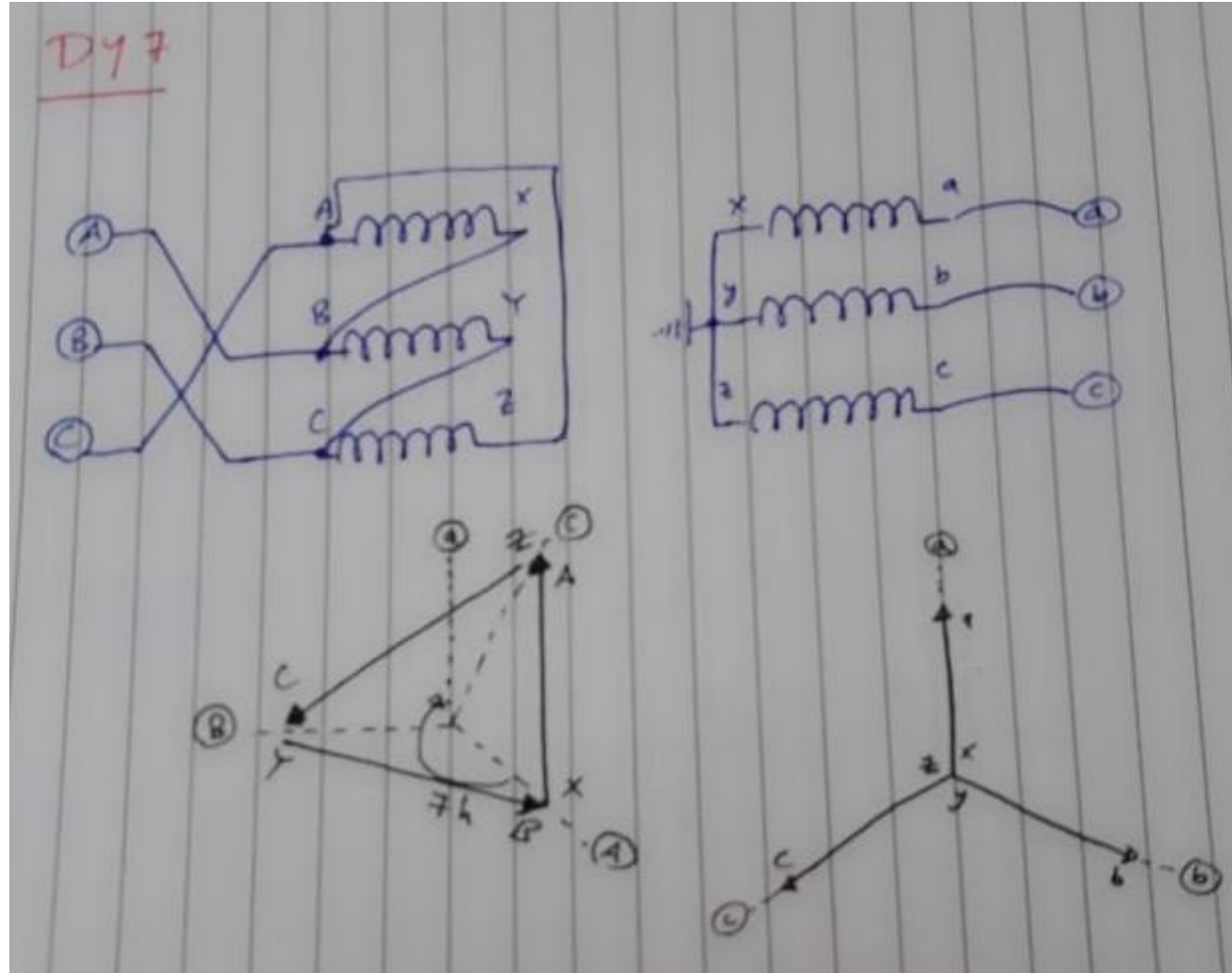

Basic Components of power systems

“Substations, differential protection of transformer”

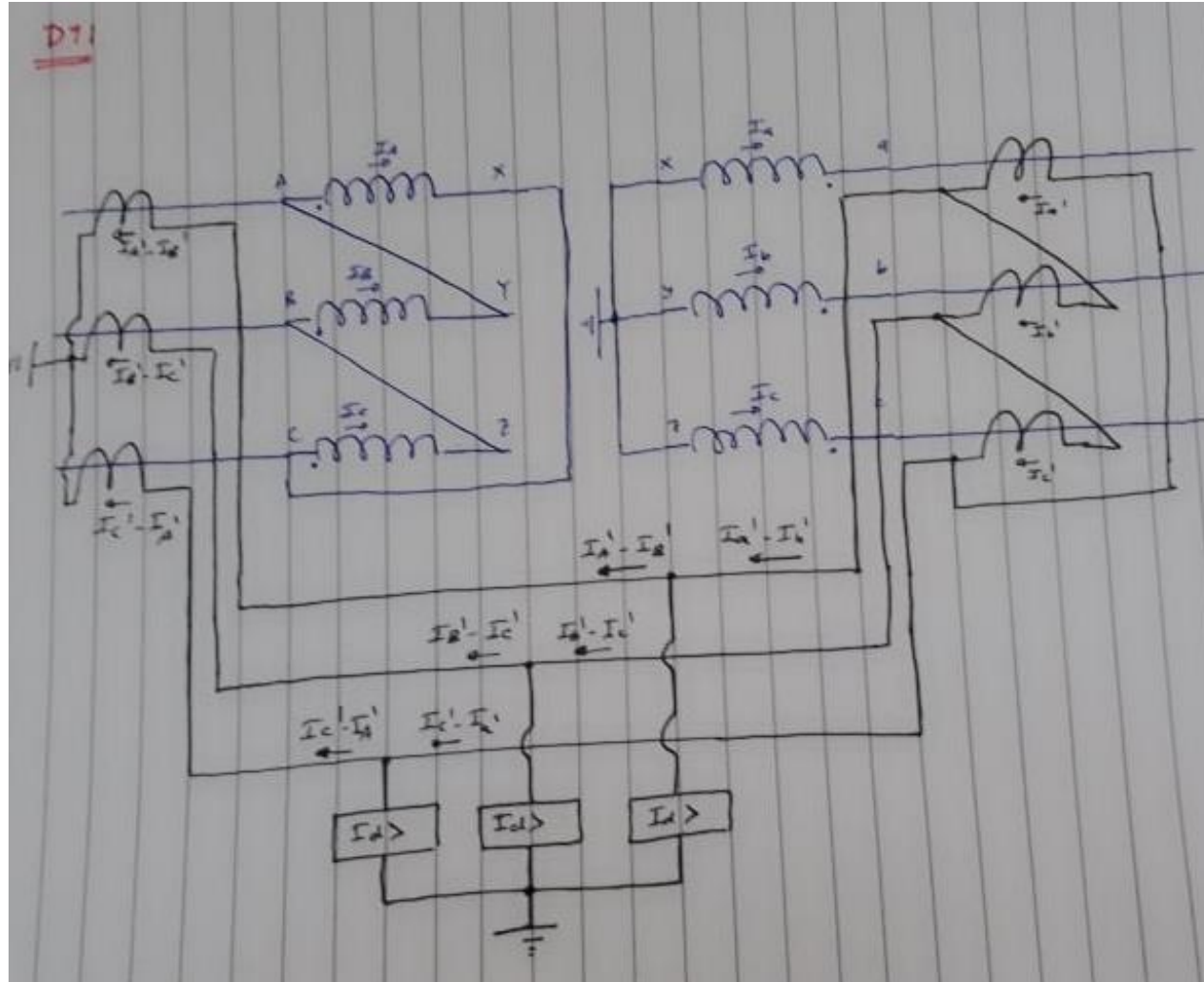

Basic Components of power systems

“Substations, differential protection of transformer”

- Transformer Ratio correction:

- CT ratio > Full load current

- For a transformer of rating S_n , the full load currents will be:

$$I_{LV} = \frac{S_n}{\sqrt{3}V_{LV}}, \quad I_{HV} = \frac{S_n}{\sqrt{3}V_{HV}}$$

- For CT secondary currents of 1 A. Choose the nearest ratio to

$$I_{LV} : 1, \quad I_{HV} : 1$$

For Y connected CTs

$$\sqrt{3}I_{LV} : 1, \quad \sqrt{3}I_{HV} : 1$$

For Δ connected CTs

Basic Components of power systems

“Substations, current transformer”

Example

Transformer: $V_H = 132$ kV, $V_L = 33$ kV, Yd1, $S_n = 25$ MVA

Available CT ratios

50:1, 60:1, 150:1, 200:1, 300:1 400:1, 500:1. 600:1, 750:1, 1000:1, 1250:1, 1500:1, 2000:1

Design a suitable differential protection including:

- Transformer and CT connection diagram
- Find the suitable CT ratio
- Find a protection setting current assuming that it should be at least 10 times the full load spill current.

Basic Components of power systems

“Substations, differential protection of transformer”

- Transformer nominal currents:

$$I_{Ln} = \frac{S_n}{\sqrt{3}V_{LV}} = 437.39, \quad I_{Hn} = \frac{S_n}{\sqrt{3}V_{HV}} = 109.35 \text{ A}$$

- Selection of CT ratios:

$$CT_H \geq \sqrt{3}I_{Hn} = 189.39 \text{ A},$$

$$CT_H = 200 : 1$$

$$CT_L \geq I_{Ln} = 437.39 \text{ A},$$

$$CT_H = 500 : 1$$

Basic Components of power systems

“Substations, differential protection of transformer”

- Full load spill current

$$I_{spill} \geq \left| \frac{\sqrt{3}I_{Hn}}{CT_H} - \frac{I_{Ln}}{CT_L} \right| = 0.072 \text{ A},$$

- Relay setting

$$I_s = 10I_{spill} = 0.72 \text{ A},$$

Basic Components of power systems

“Substations, differential protection of transformer”

Effect of transformer magnetizing inrush

- Suppose that the voltage has a phase shift of θ :

$$v_p = V_m \sin(\omega t + \theta)$$

- Then, the flux in the core is:

$$\phi = \frac{1}{N_p} \int v_p dt = \frac{1}{N_p} \int V_m \sin(\omega t + \theta) dt = -\frac{V_m}{N_p \omega} \cos(\omega t + \theta) + A$$

where A is constant of integration. It is a transient flux that quickly decays as a result of excess eddy current and primary copper losses.

Basic Components of power systems

“Substations, differential protection of transformer”

- After few cycles, the flux becomes

$$\phi = -\frac{V_m}{N_p \omega} \cos(\omega t + \theta)$$

- Such that, the maximum flux in steady state is:

$$\phi_{\max} = \frac{V_m}{N_p \omega}$$

Basic Components of power systems

“Substations, differential protection of transformer”

- Assume that the residual flux in the core is zero, then

$$\phi(0) = -\frac{V_m}{N_p \omega} \cos(\theta) + A = \phi_R = 0 \Rightarrow A = \frac{V_m}{N_p \omega} \cos(\theta)$$

- Then, the flux in the core is:

$$\phi = -\frac{V_m}{N_p \omega} \cos(\omega t + \theta) + \frac{V_m}{N_p \omega} \cos(\theta)$$

$$\phi = -\phi_{\max} \cos(\omega t + \theta) + \phi_{\max} \cos(\theta)$$

Basic Components of power systems

“Substations, differential protection of transformer”

- When $\theta = 0$ and $\omega t = \pi$, we get

$$\phi = -\phi_{\max} \cos(\omega t + \theta) + \phi_{\max} \cos(\theta) = 2\phi_{\max}$$

which is the **worst case**, as it results in a very large magnetizing current.

- The transformer looks like a short circuit and a very large starting current flows, which is called **an inrush current**.

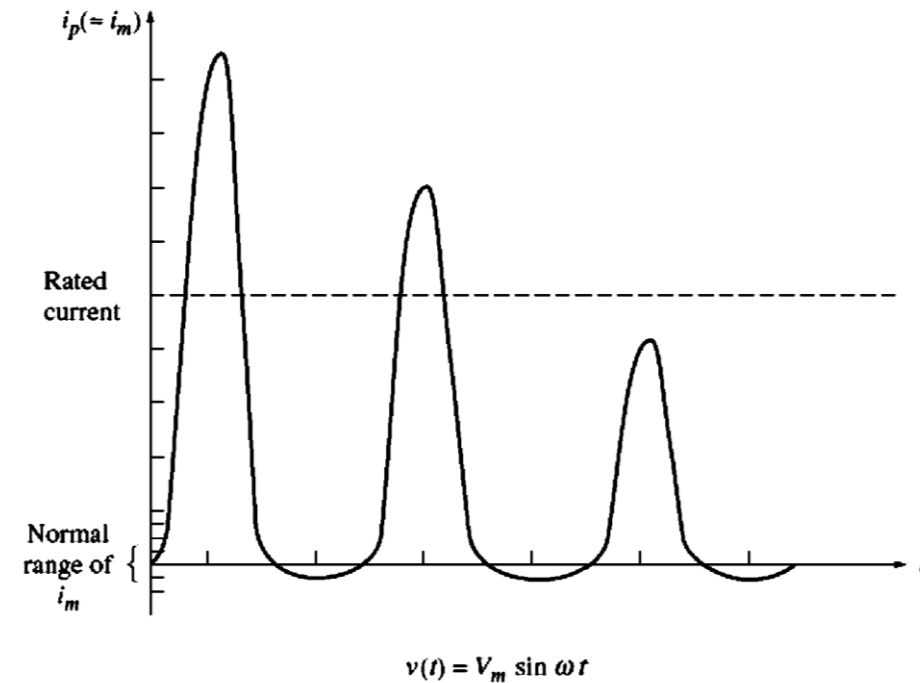

Basic Components of power systems

“Substations, differential protection of transformer”

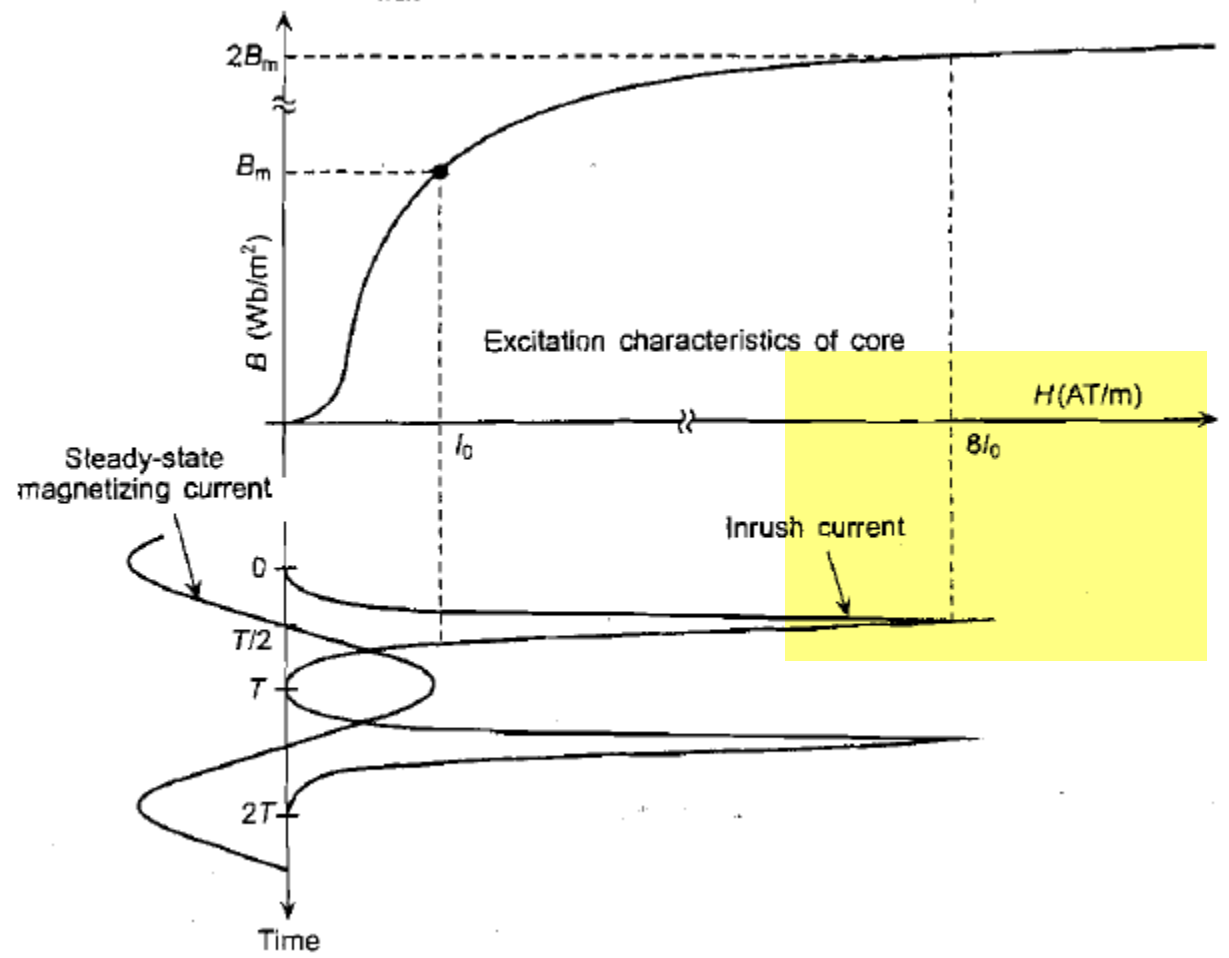
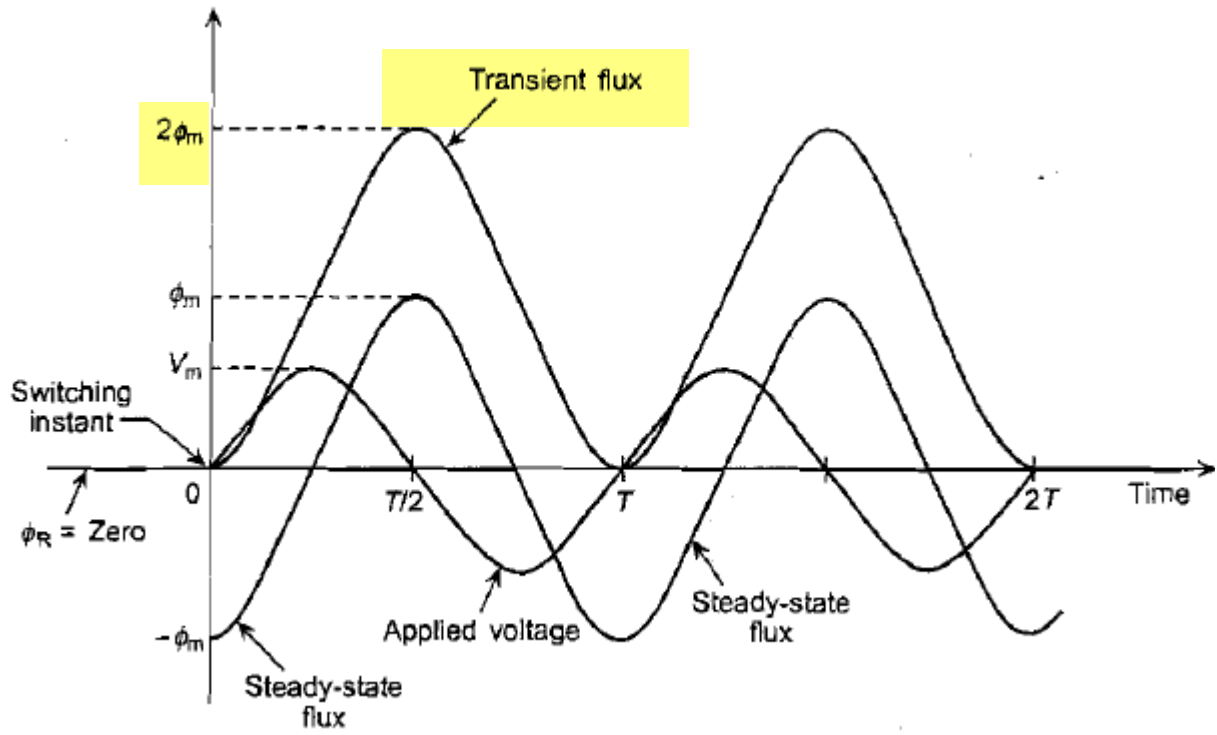

Basic Components of power systems

“Substations, differential protection of transformer”

- The magnetizing inrush happens when the transformer is energized. Its value can reach 500% of the steady state magnetizing current.
- It is not a fault condition. Therefore, the protection should remain stable.
- Nuisance of tripping can be prevented by:
 - Second harmonic restraint
 - Blocking by gap-detection technique

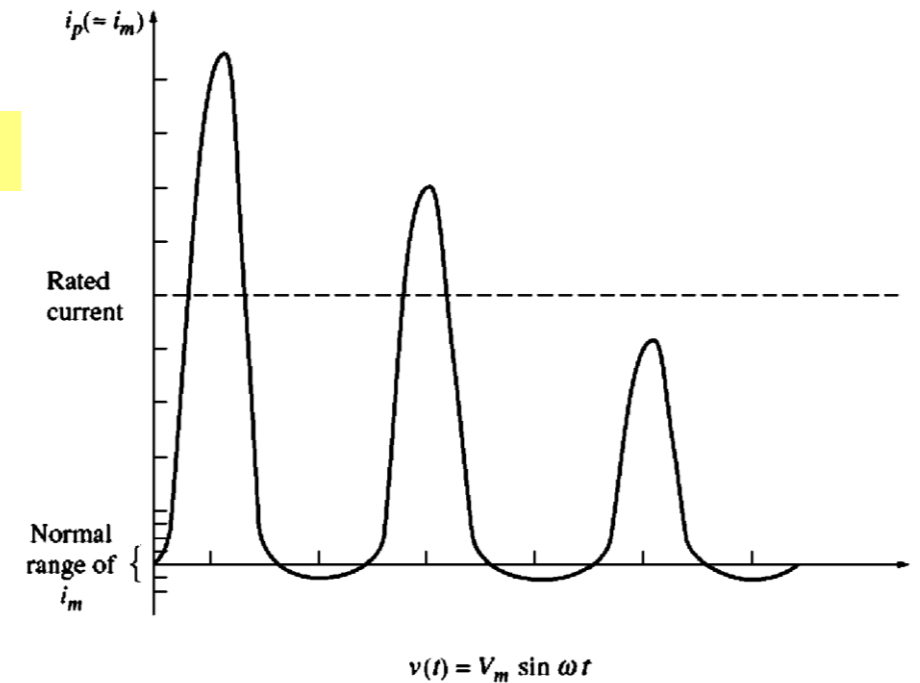

Basic Components of power systems

“Substations, differential protection of transformer”

- **Second harmonic restraint**
 - The magnetizing inrush contains a significant **2nd** harmonic component. However, the normal fault currents do not contain **even harmonics**
 - The problem is solved using **numerical relays**

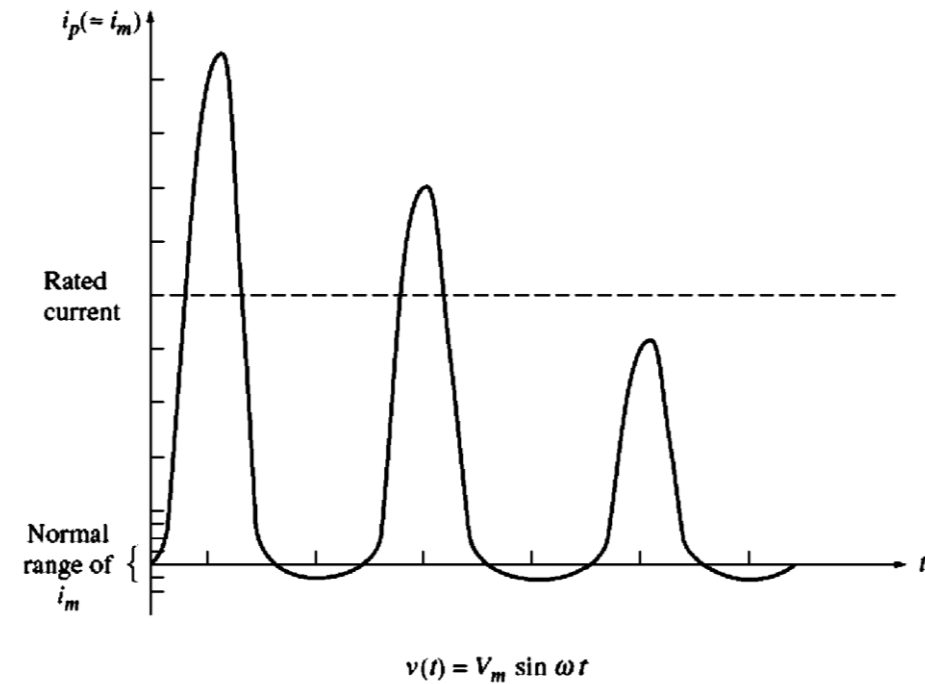

Basic Components of power systems

“Substations, differential protection of transformer”

- Gap detection technique

- The magnetizing inrush currents have periods in the cycle when the instantaneous value of the current is zero
- The minimum duration of the zero period is a quarter of the cycle (5 ms)
- The problem is solved using digital (logic) relays

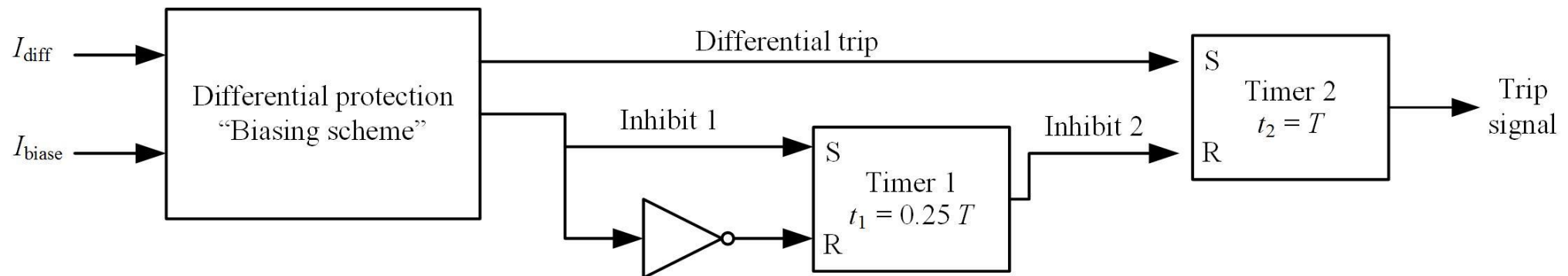

Basic Components of power systems

“Substations, differential protection of transformer”

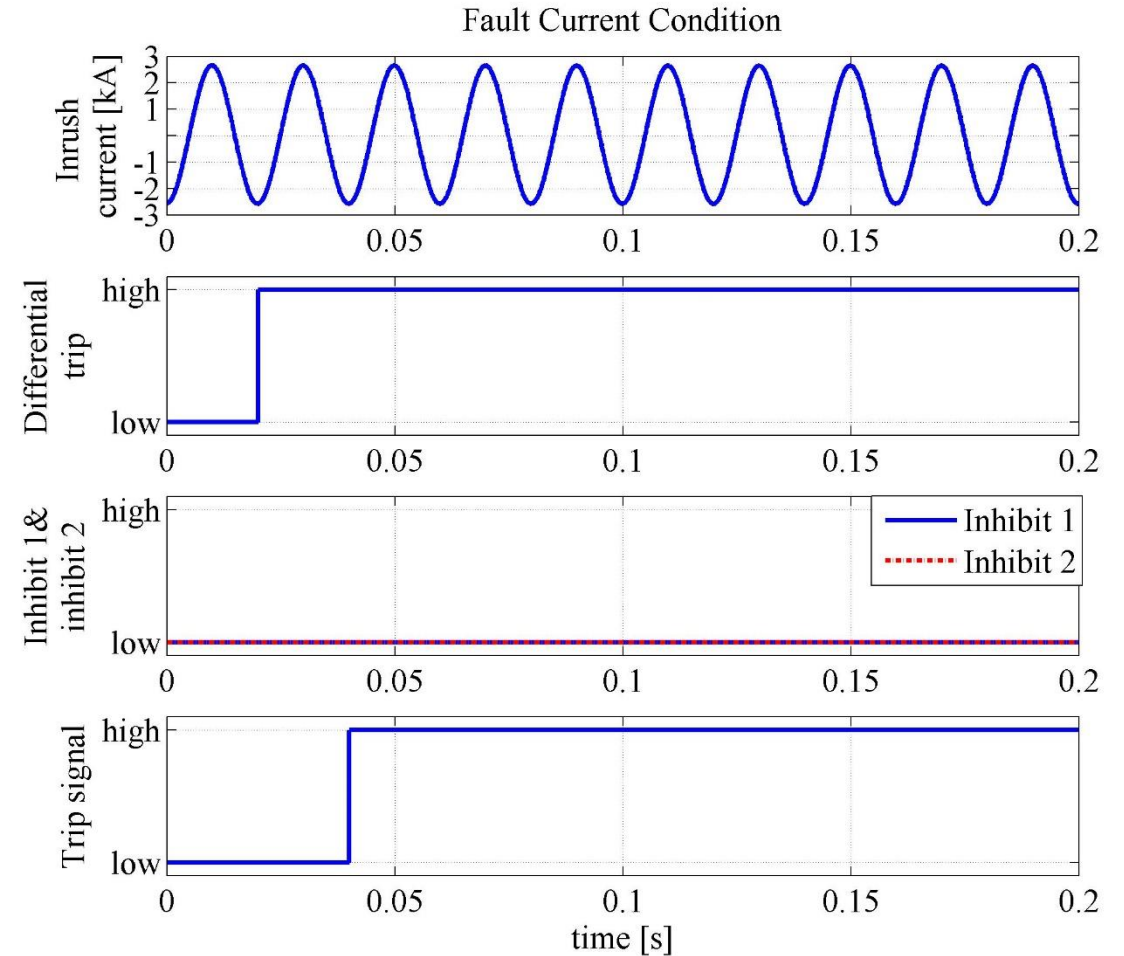
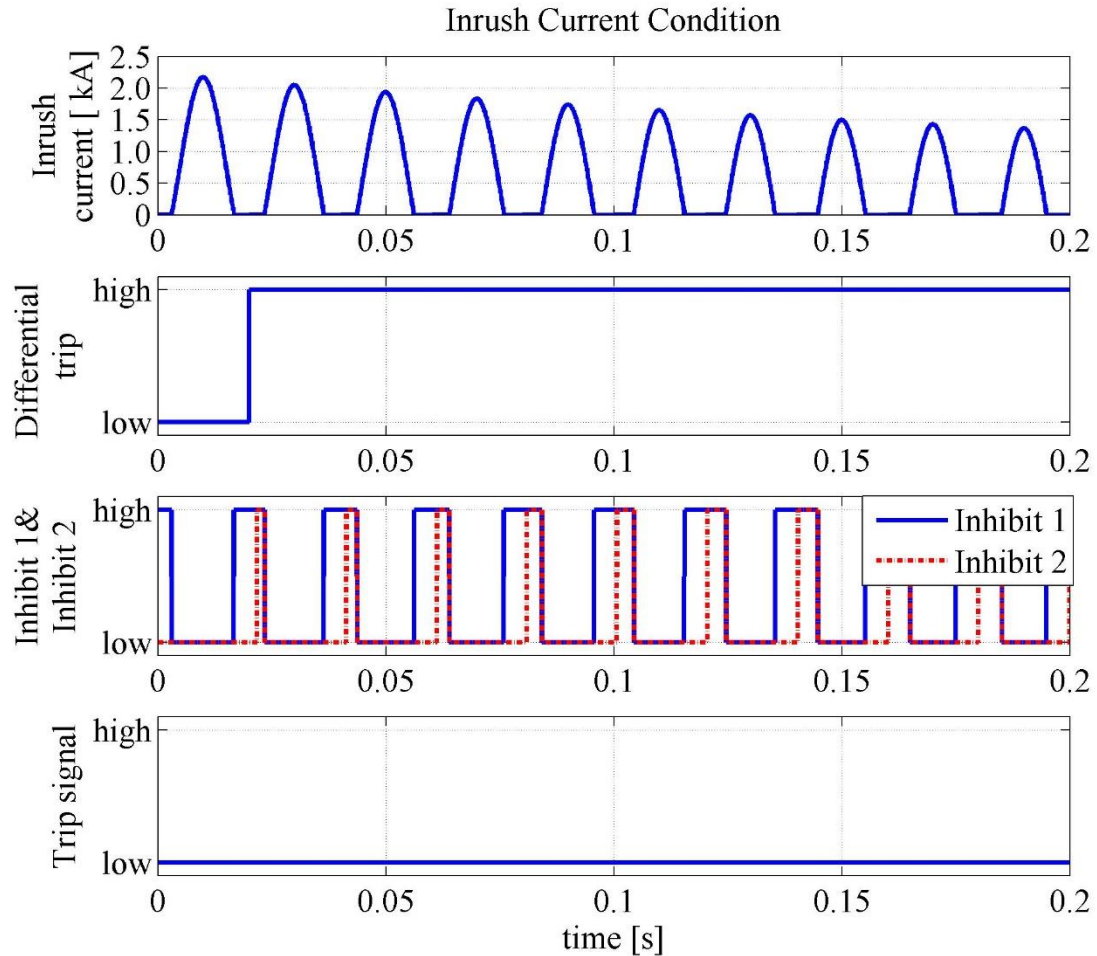

Basic Components of power systems

“Substations, differential protection of feeder”

- The length of the protected circuit is the main challenge
- Pilot wire scheme (copper pilots) is usually used for distance over 25 km (< 25 km)
- Pilot means existence of communication channel of wire between two ends of a transmission system over which the exchange of information takes a place.
- Only one pilot is used per circuit (feeder)
- Summation transformer is required to drive a single phase quantity from three phase current inputs. It is used to minimize the pilot cable cost.

Basic Components of power systems

“Substations, differential protection of feeder”

- Circuits longer than 25 km can not use copper pilot wires.
- In this case, other forms of communication media used such as power line carrier.
- It is impossible to send 50 Hz directly, the signal must be encoded using higher frequency carrier.
- Normally, only comparison of current phase (not magnitude) is made.

Basic Components of power systems

“Substations, differential protection of feeder”

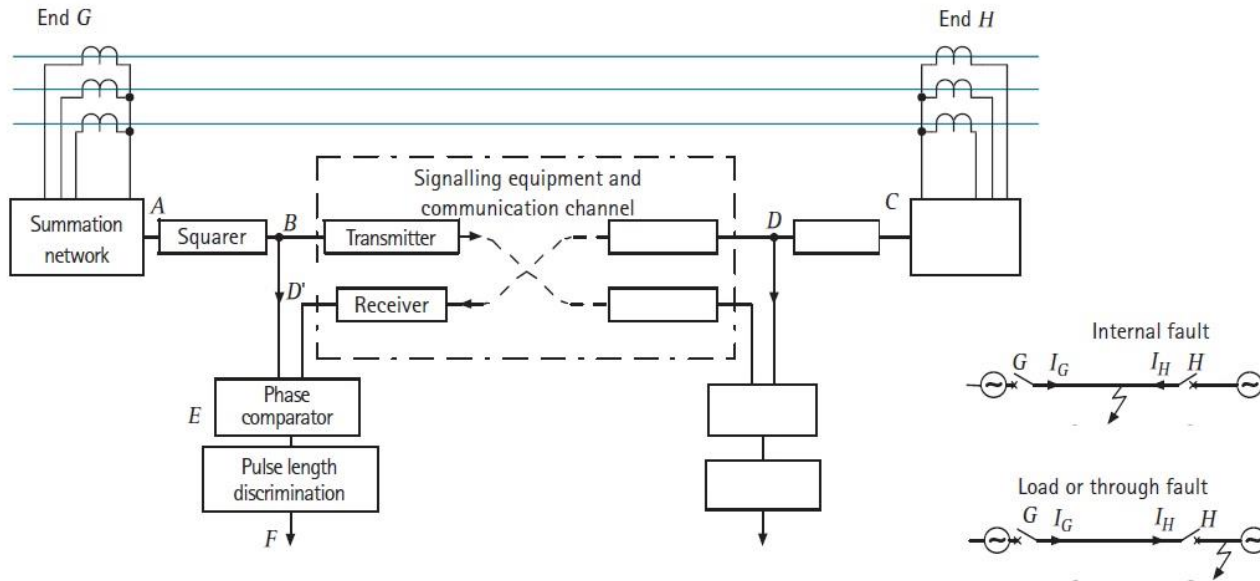

A. Summation voltage at end G

B. Squarer output at end G

C. Summation voltage at end H

D. Squarer output at end H
(Received at end G via ideal carrier system as D')

E. Comparator output at end G
 $E = \overline{B + D'}$

F. Discriminator output at end G

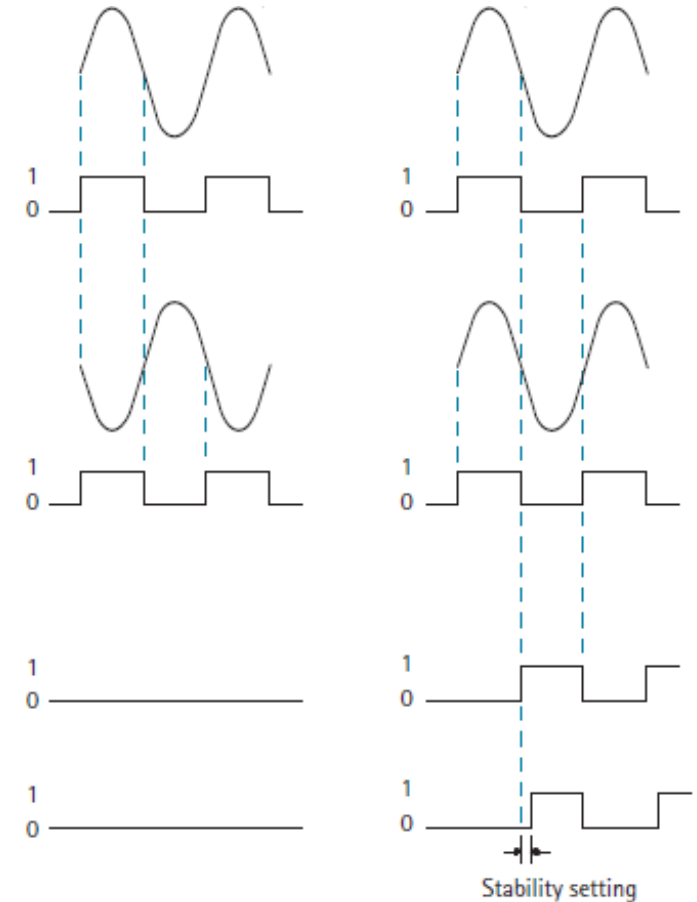

Basic Components of power systems

“Substations, differential protection of feeder”

- The stability angle must accommodate for
 - CT phase errors
 - Propagation delays (1 degree/ 17 km)
 - Charging current of the line

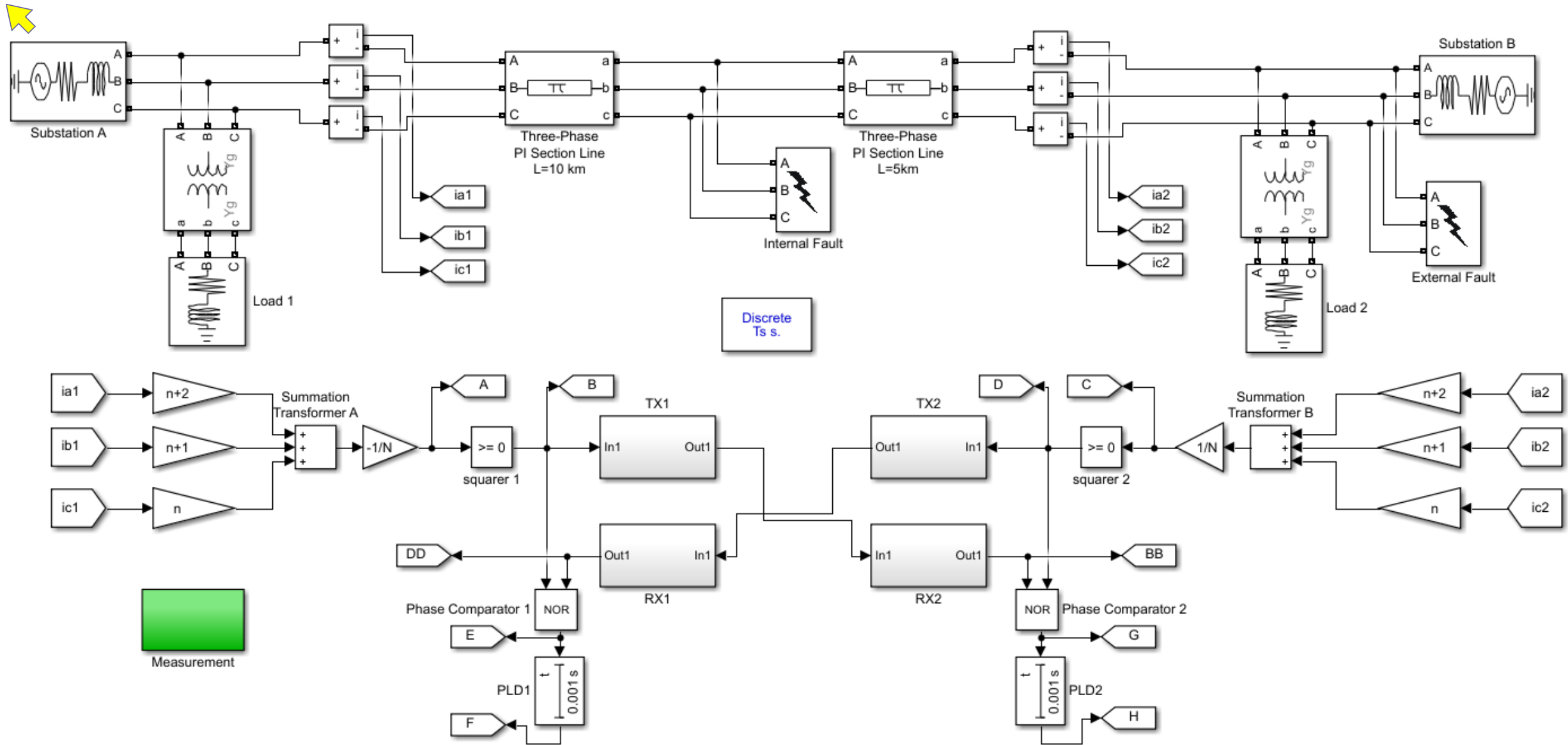

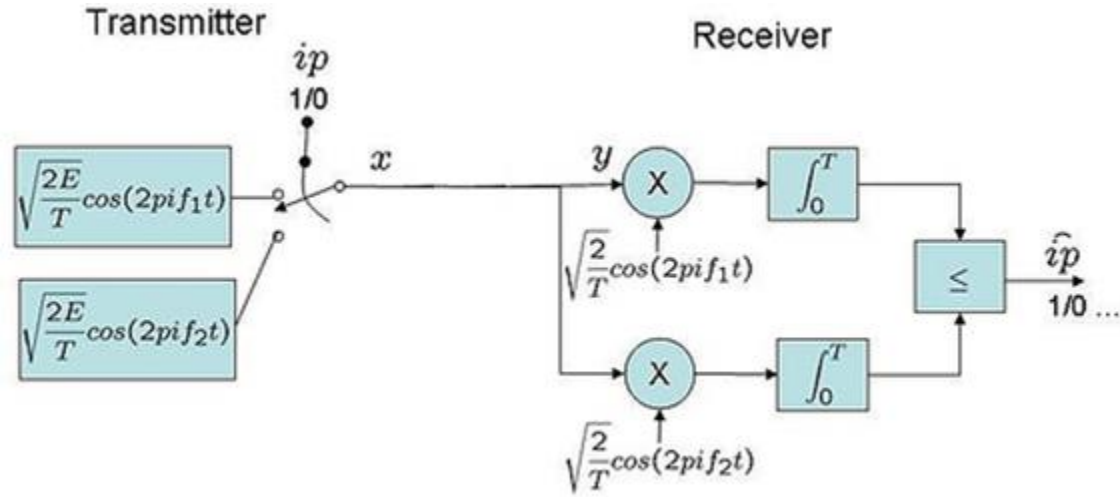

TX results

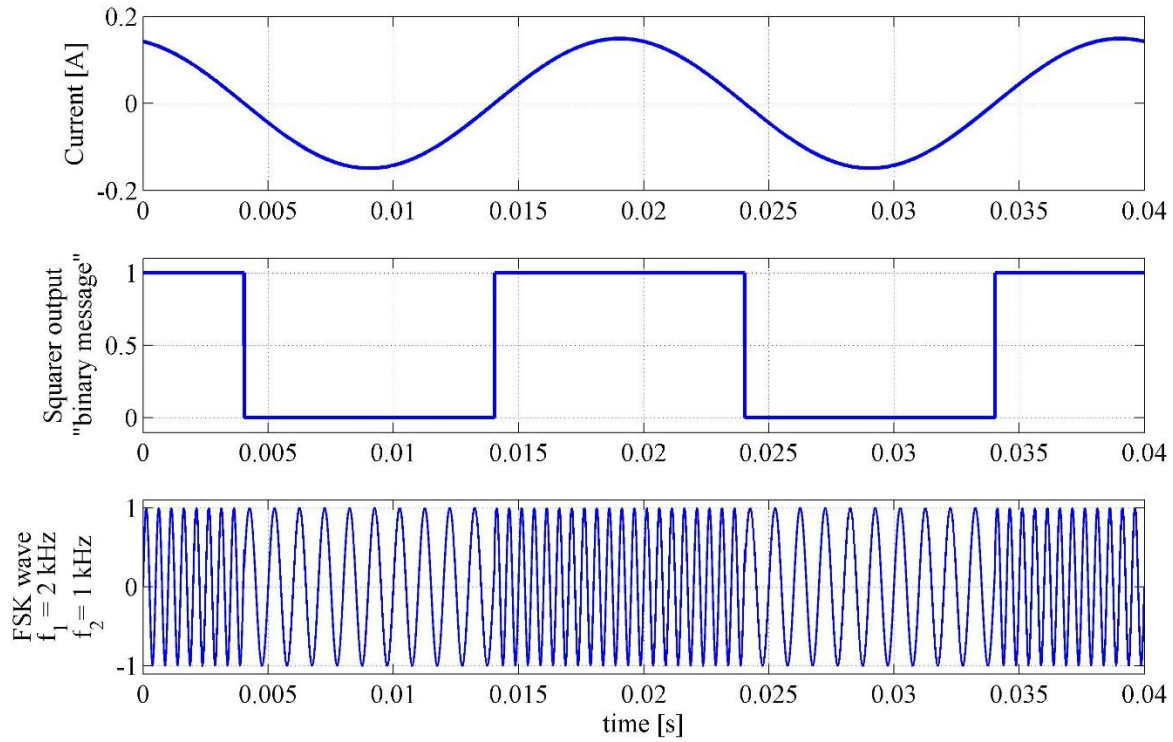

RX results

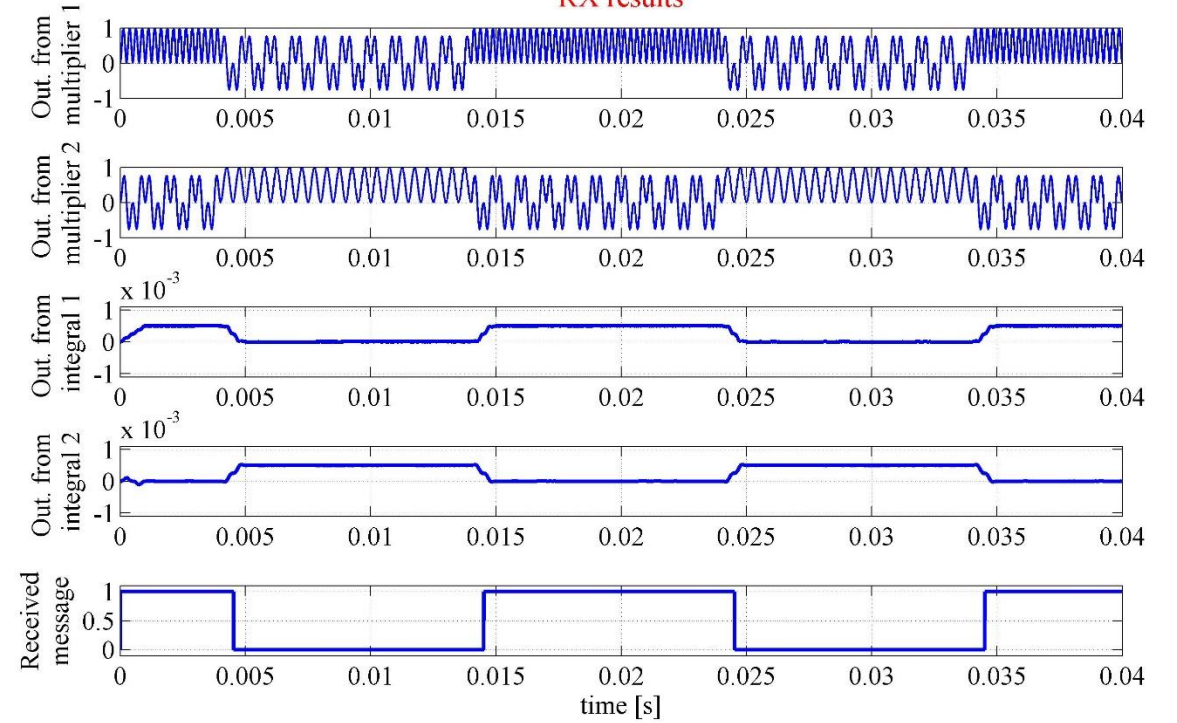

Internal Fault Condition

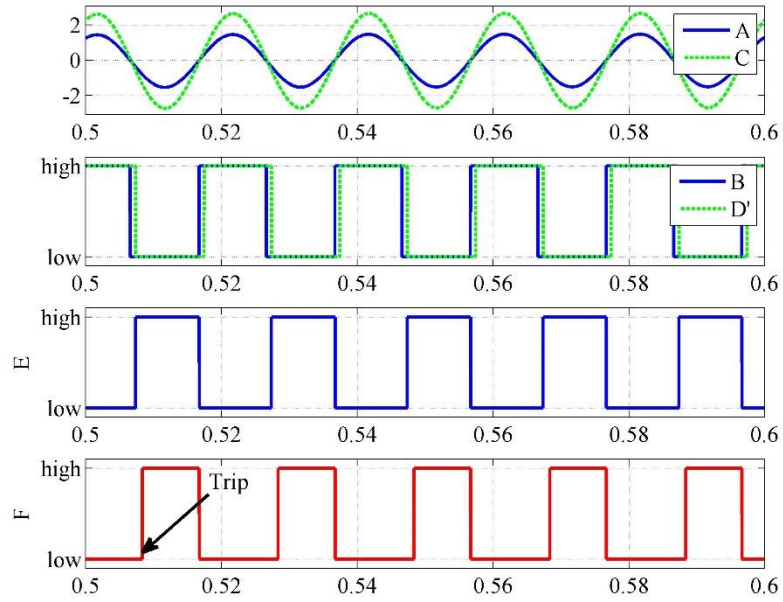

External Fault Condition

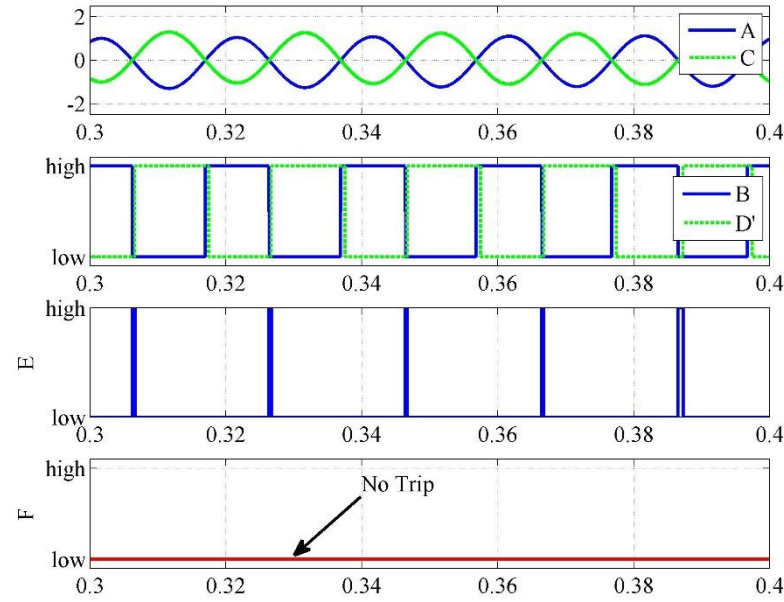

Normal Condition

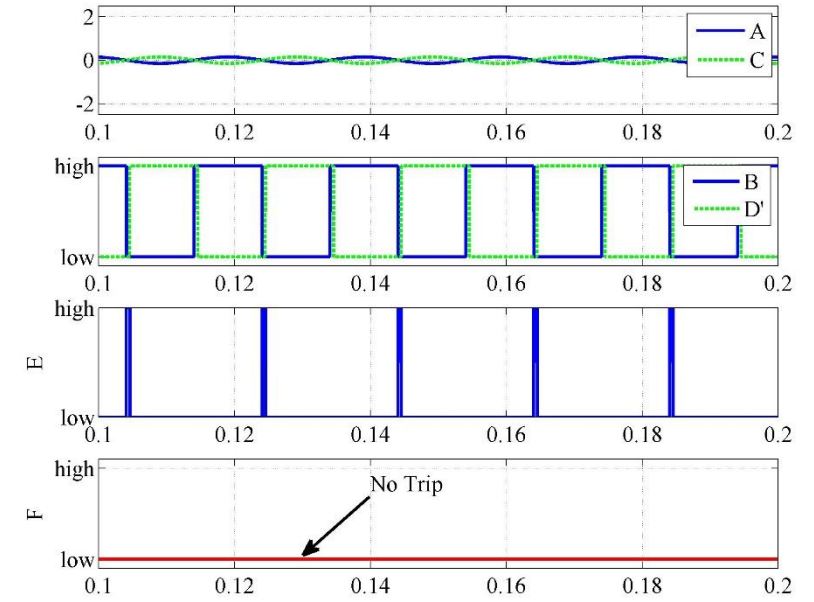

Basic Components of power systems

➤ “Substations, circuit breaker”

- A circuit breaker (CB) is a high voltage mechanical switching device, capable of making, carrying and breaking load current during normal operation and interrupt large fault current in abnormal conditions.
- The breaker can be operated by a trained substation personnel by pressing the button at the control room. But during the fault condition it trips automatically.
- The following is required from a circuit breaker:
 - In the closed position it must be a good conductor;
 - In the open position it must behave as a good isolator between system parts;
 - It must be able to change from the closed to open position in a very short period of time (typically in less than 0.1 second);
 - It does not cause overvoltages during switching;
 - It is reliable in its operation.

Basic Components of power systems

“Substations, circuit breaker”

- Main components of CB
 - Main contacts
 - Auxiliary contacts
 - Trip coil
 - Latching mechanism

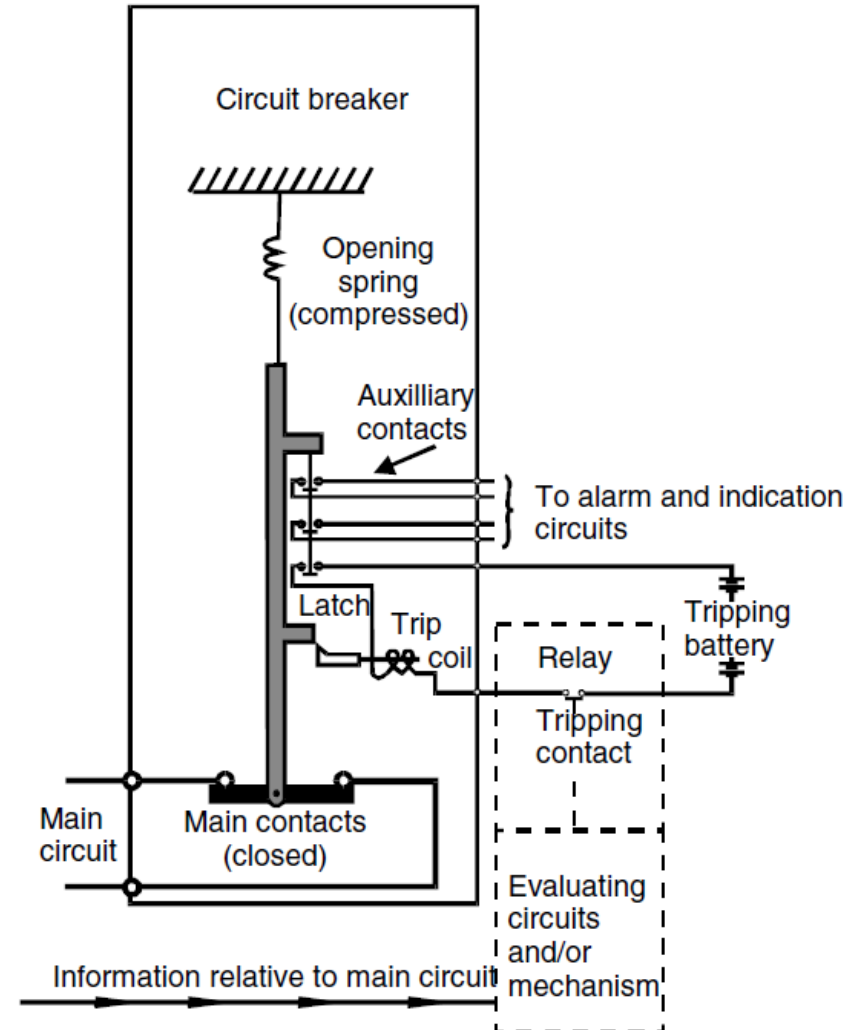

Basic Components of power systems “Substations, circuit breaker”

- When fault in the line takes place, the large fault current is associated with the increase of secondary current in the CT.
- This will actuate the relay and relay contact closes.
- Now as the tripping circuit of the breaker is complete, the trip coil is energized.

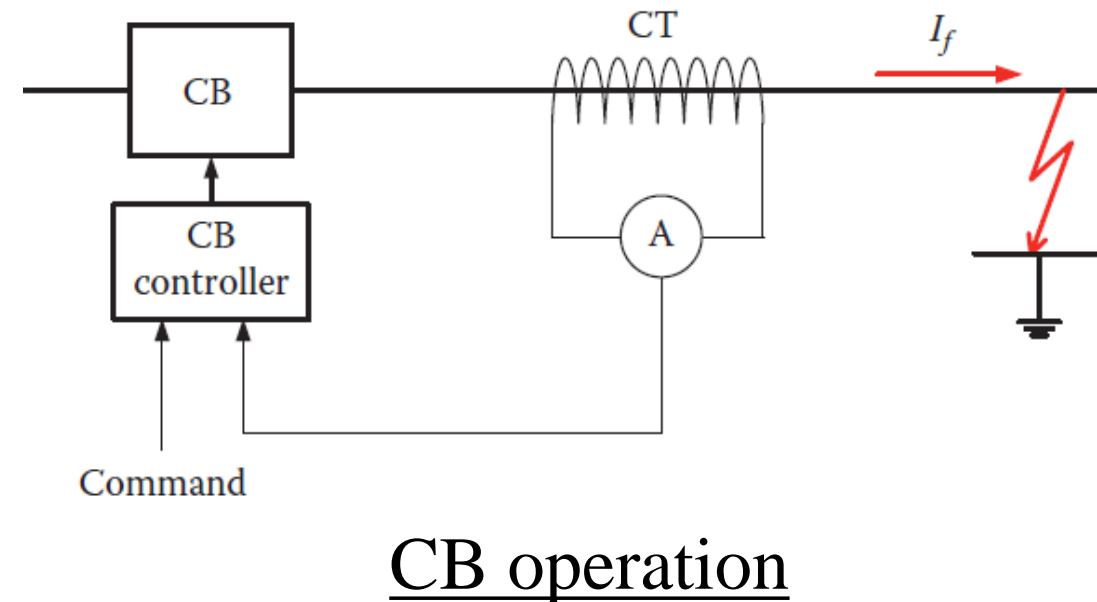

Basic Components of power systems

“Substations, circuit breaker”

- The energized trip coil initiates breaker mechanism for moving the circuit breaker moving contact away from fixed contact.
- The arc formed between the moving contact and fixed contact is extinguished by **breaker arc extinguishing mechanism.**
- Finally, **the breaker is opened.**

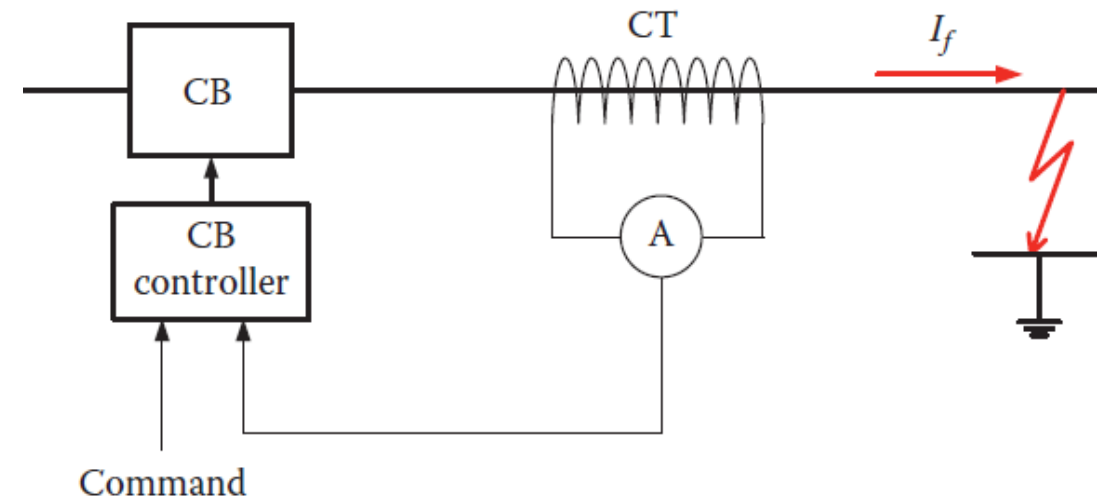

CB operation

Basic Components of power systems “Substations, circuit breaker”

- From the figure it is clear that the breaker trip circuit can be closed by closing of either of the contacts C1 or C2.
- While C1 is for manual closing by pressing the button at the control panel, the C2 is closed automatically by breaker relay for abnormal over current condition sensed by CT.
- **These two contacts in parallel fulfil the logic OR function.**

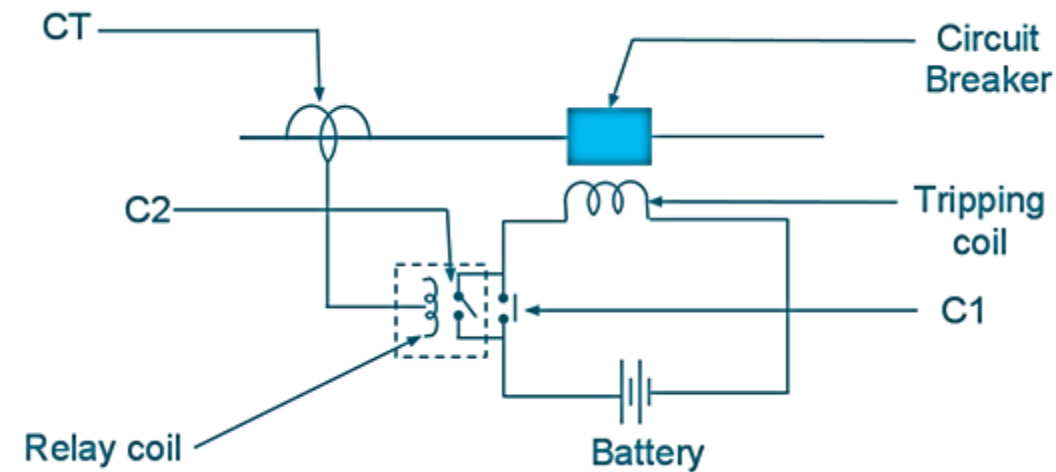

CB operation

Basic Components of power systems

“Substations, circuit breaker”

- During separation of moving contact from fixed contact **electric arc** is produced between the contacts.
- Extinguishing of the arc is the most important part of breaker functioning, which greatly influences the breaker design.
- The arc extinguishing is a difficult task in **HV and EHV or UHV** circuit and is the primary concern for breaker design.
- The energy stored in the line/circuit inductance is dissipated in the arc and the arc is required to be extinguished reliably.
- **The circuit breaker functioning is comprised of three main tasks.**
 - **Sensing and tripping circuit**
 - **Operating mechanism**
 - **Arc interruption**

Basic Components of power systems

“Substations, circuit breaker”

- The breakers can be classified several ways. The most important classification is the medium used for arc interruption. (oil, air, vacuum, or SF6)
- The circuit breakers are also available as single tank type or separate tank type. In case of separate tank type, each phase has a separate tank. For EHV application separate tank type breakers are preferred.
- The circuit breakers can also be classified from the point of view of operating mechanism. The operating mechanism of the circuit breaker may be hydraulic, pneumatic or motor operated types.

Basic Components of power systems “Substations, circuit breaker”

- The circuit breakers are also classified as live tank type or dead tank type.
- In case of live tank type breaker, the enclosure of the breaker is at line potential.
- In the dead tank type breaker, the enclosure of the breaker is at ground potential.
- The dead tank type breaker requires additional oil/gas for insulation from the grounded enclosure. Live tank type breaker requires less oil or gas.

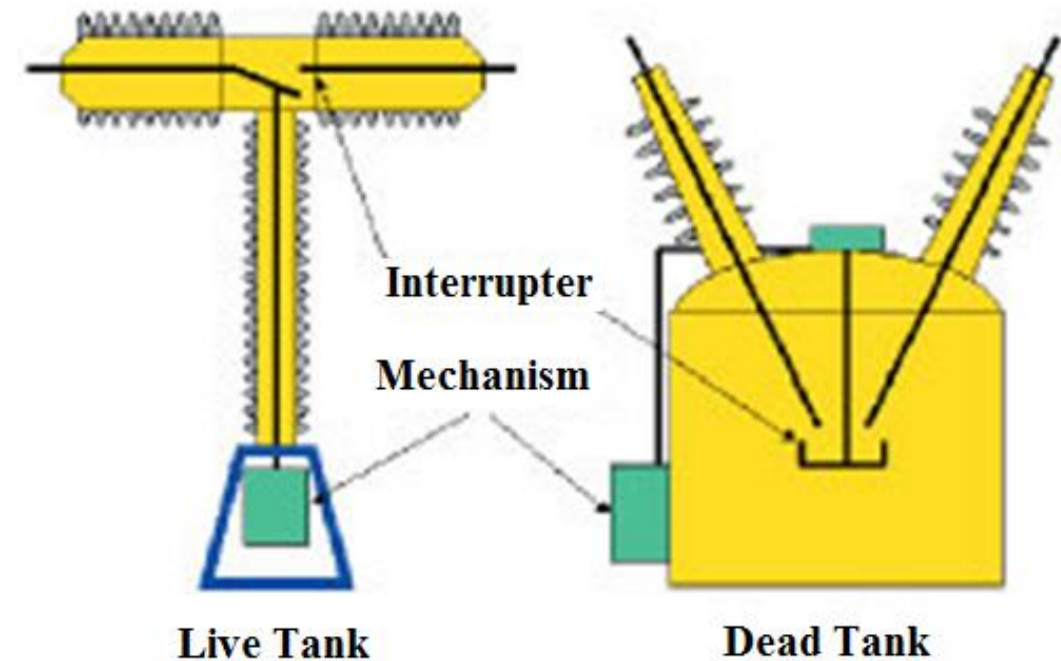

Basic Components of power systems

“Substations, circuit breaker”

High voltage breaker switching phenomena and TRV

- Circuit breaker switching results in either breaking the circuit or making the circuit.
- After a circuit breaker is closed or opened the configuration of the system changes.
- For example by opening a breaker a part of the network may be de-energised or isolated or a load may be disconnected.
- On occurrence of fault the trip signal initiates breaker mechanism so that the breaker contacts separate, and arc is formed between the contacts.
- The arc is extinguished at current zero. **But there are chances of re-striking.**

Basic Components of power systems

“Substations, circuit breaker”

L : The equivalent inductance up to the breaker.

R : The line resistance being small and is neglected.

C : The the equivalent capacitance due to the equipment bushings.

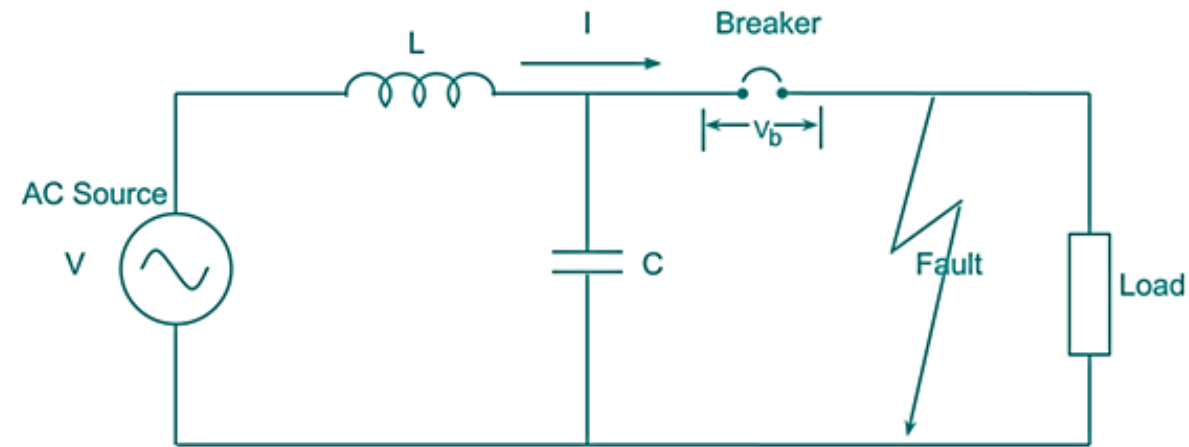

Representation of equivalent circuit and fault

Basic Components of power systems

“Substations, circuit breaker”

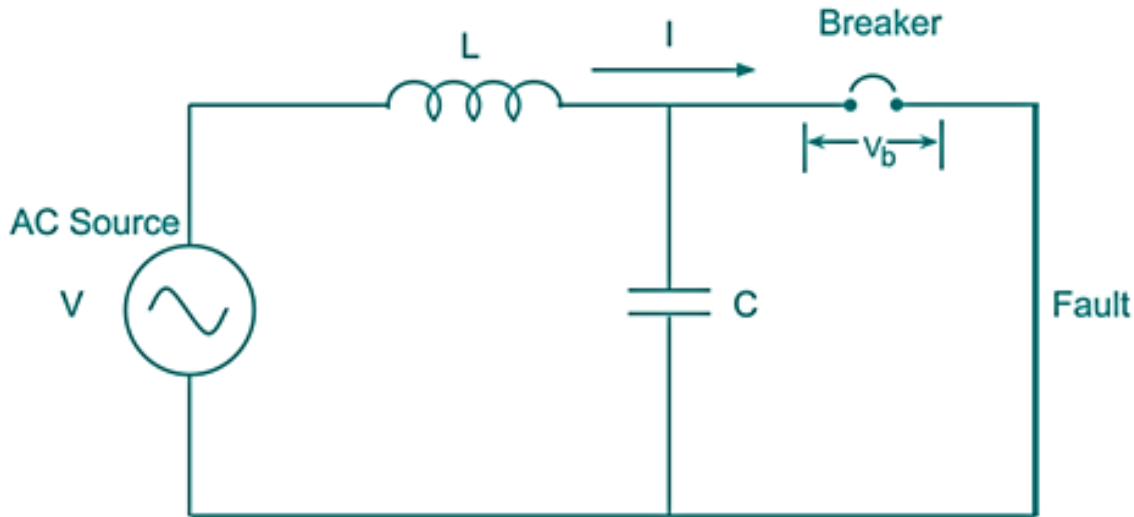

Equivalent circuit and fault current flow during arcing

The voltage across the poles of the breaker is the voltage drop across the arc. ($V_b = 0$)

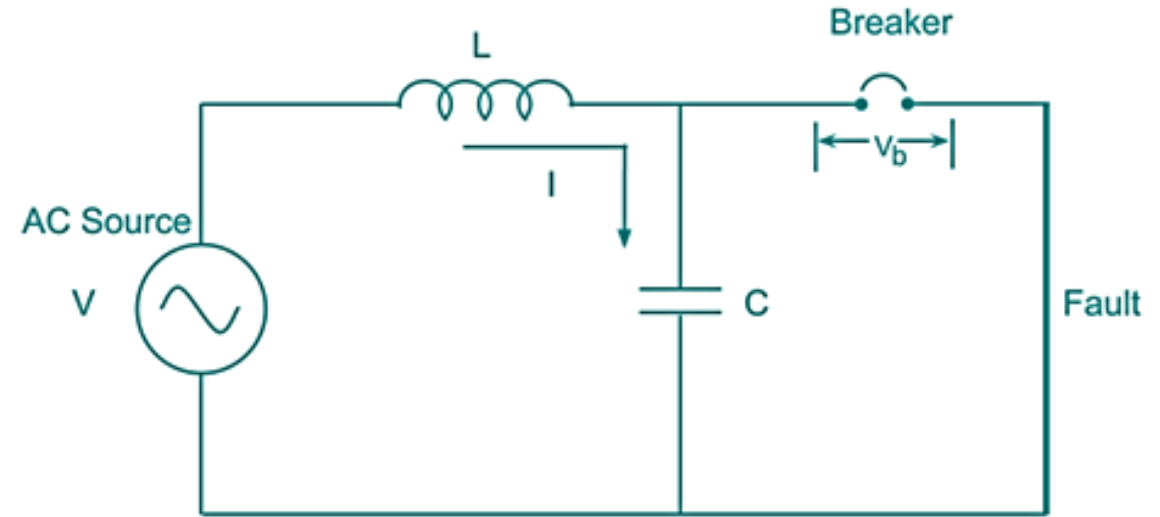

Equivalent circuit and current flow just after interruption of arc

The voltage across the poles of breaker is the voltage across the capacitance C . ($V_b \neq 0$)

Basic Components of power systems “Substations, circuit breaker”

Current-interruption in a purely inductive AC circuit.

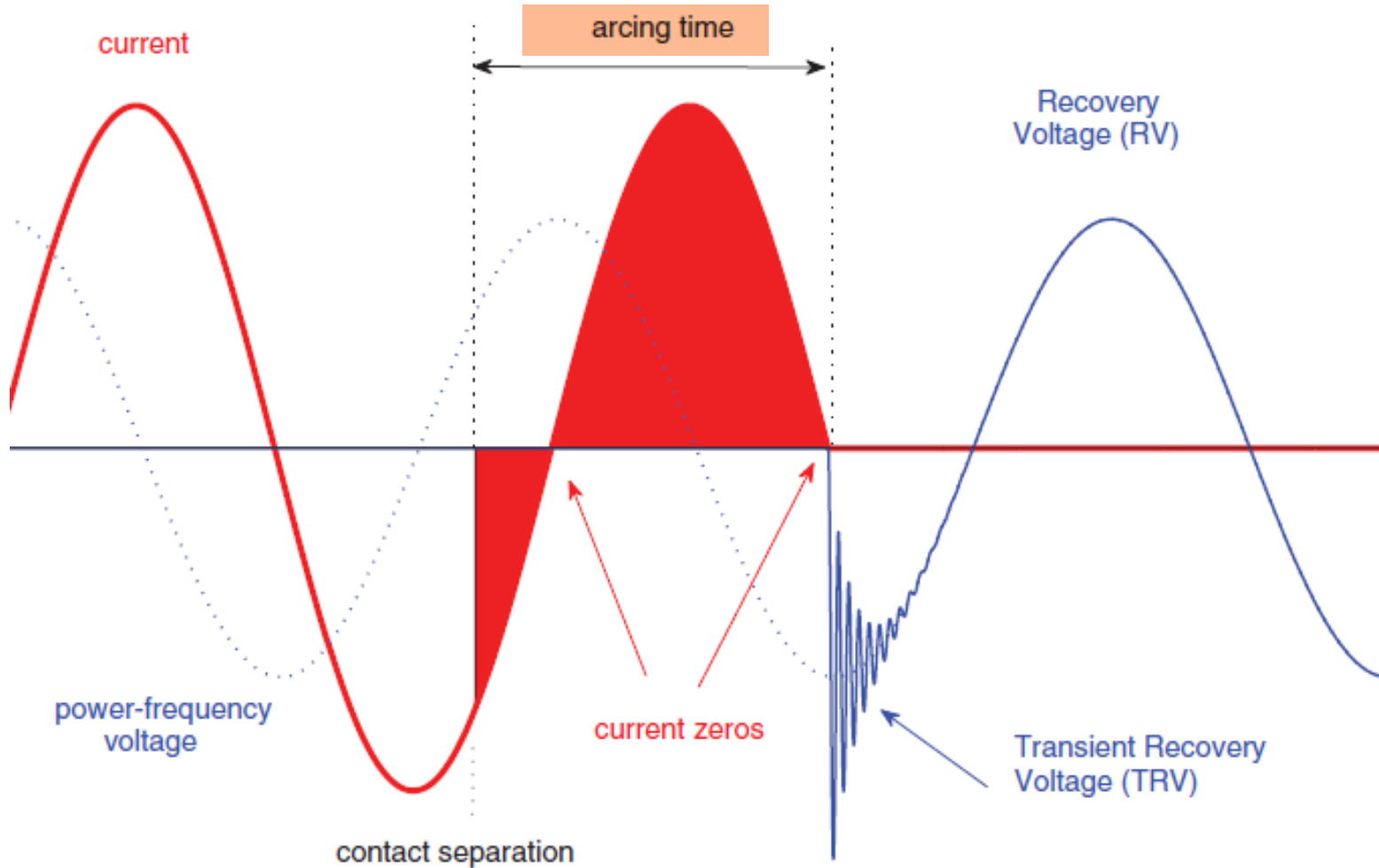

Basic Components of power systems “Substations, circuit breaker”

Current zero and transient recovery voltage in an inductive AC circuit.

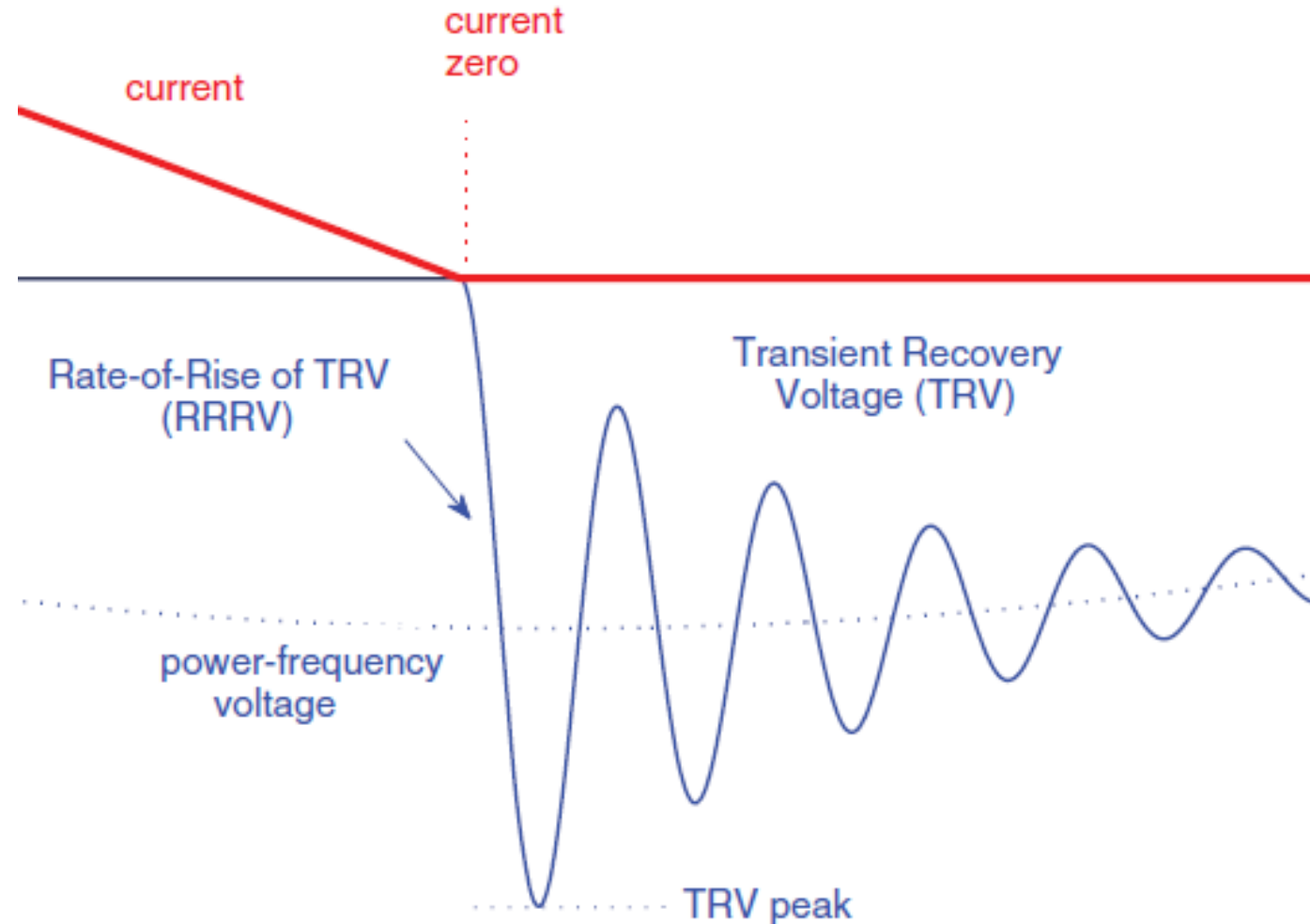

Basic Components of power systems

“Substations, circuit breaker”

- The voltage across the poles of breaker after arc extinction is called as the **recovery voltage**.
- But the transient part just after current zero is called as **Transient Recovery Voltage (TRV)**.
- After the transient vanishes within few microseconds, the voltage across the poles is called **Recovery Voltage** which is at power frequency.
- It should be noted that the **Transient Recovery Voltage** is also known as **Restriking Voltage**.

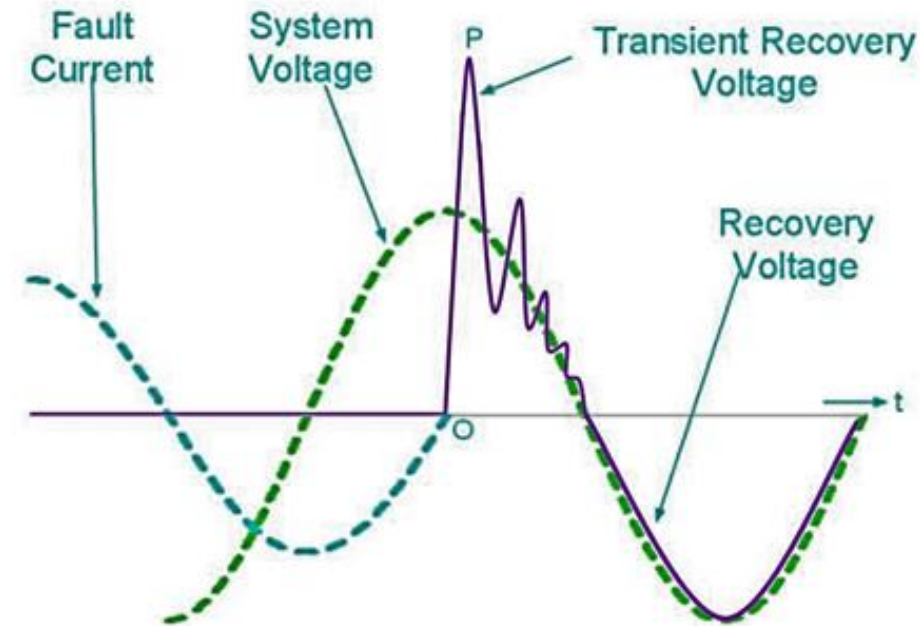

Basic Components of power systems

“Substations, circuit breaker”

- The voltage across the capacitance which is the voltage across the breaker poles approaches the system voltage in an oscillatory manner due to the formation of **series LC circuit**.
- The frequency of oscillation of the transient is very high in comparison to the power frequency at 60 Hz or 50 Hz . If f_0 is the frequency of oscillation of the transient voltage then,

$$f_0 = \frac{1}{2\pi\sqrt{LC}} \gg 50 \text{ Hz or } 60 \text{ Hz,}$$

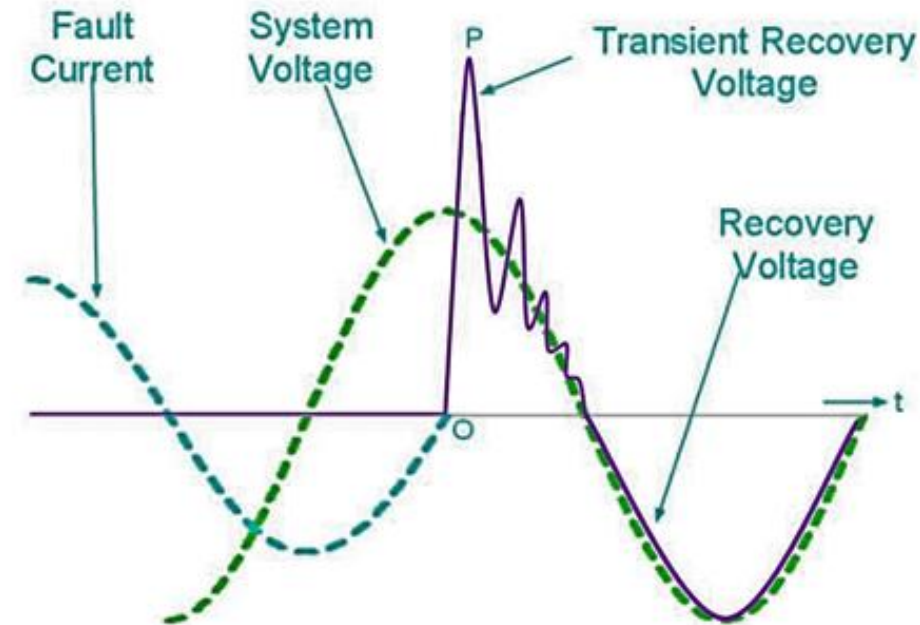

Basic Components of power systems

“Substations, circuit breaker”

- The amplitude of oscillation is gradually damped due to the presence of the small line/equipment resistance.
- The peak value of the TRV can be very high. In testing and standardization, the damping is expressed by the amplitude factor k_{af} , defined as the ratio between the transient peak value and the steady-state value. The value of k_{af} is in the range $1 < k_{af} \leq 2$.

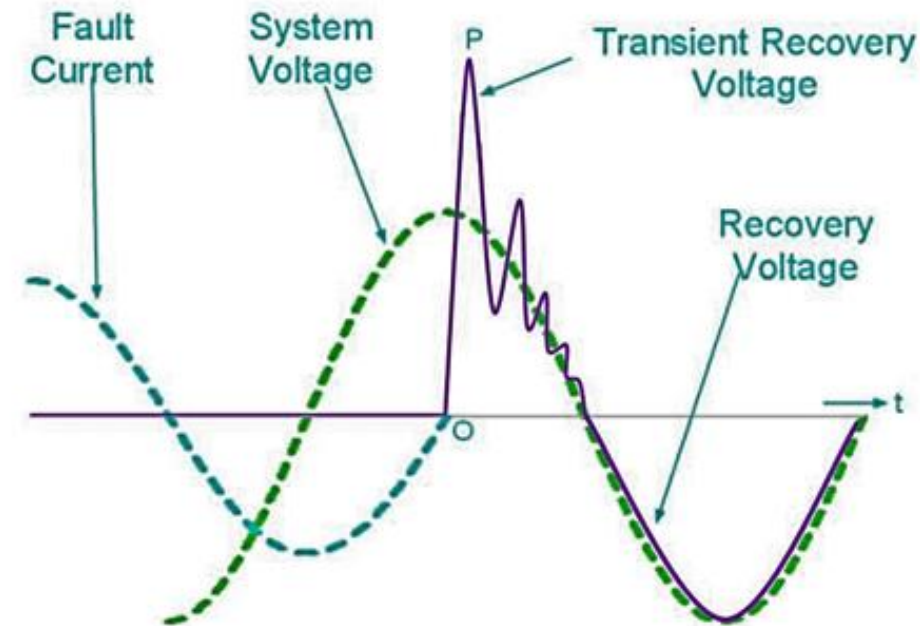

Basic Components of power systems

“Substations, circuit breaker”

- The rate of rise of this Transient Recovery Voltage and the value of the peak voltage are very important for successful arc quenching ability of breaker.
- If rate-of-rise of recovery voltage (RRRV) is higher than the rate of gain in dielectric strength of the medium between the breaker contacts then restrike will happen and arc is again formed between the contacts, feeding the fault for another half cycle at least till next current zero is encountered.

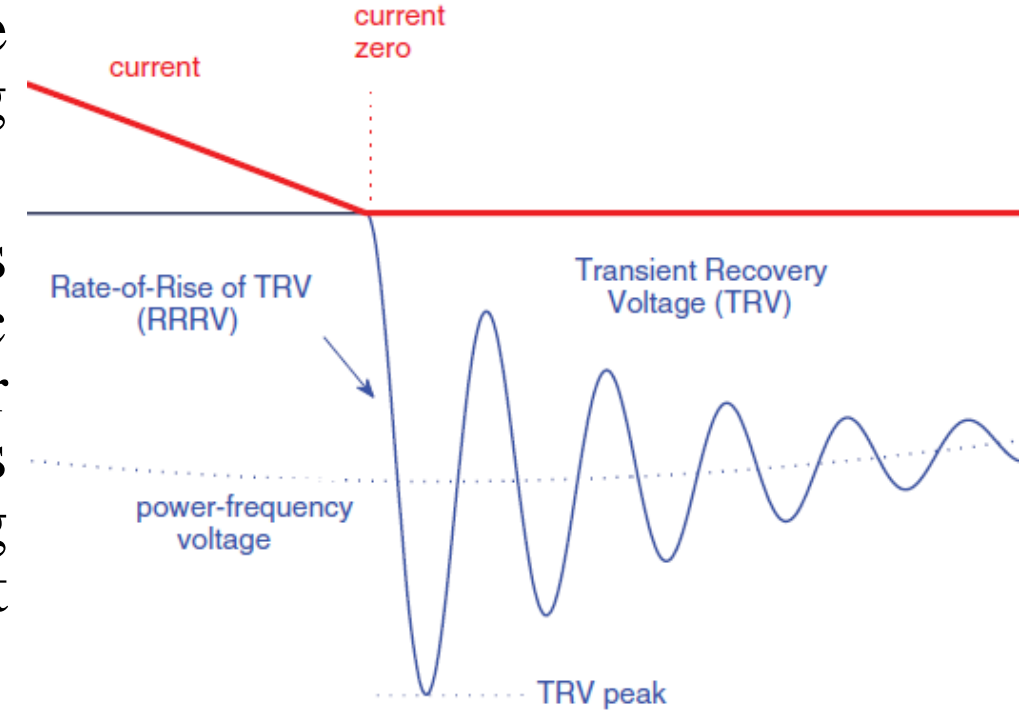

Basic Components of power systems

“Substations, circuit breaker”

- Derivation of RRRV
- By applying KVL in the loop, we get

$$v_s = L \frac{di}{dt} + v_{CB} \quad i = C \frac{dv_{CB}}{dt}$$

where v_s is the system voltage at the instant of arc interruption. As the transient oscillation is a fast phenomenon, v_s can be regarded as a constant for a short duration.

$$v_s = LC \frac{d^2 v_{CB}}{dt^2} + v_{CB} \approx V$$

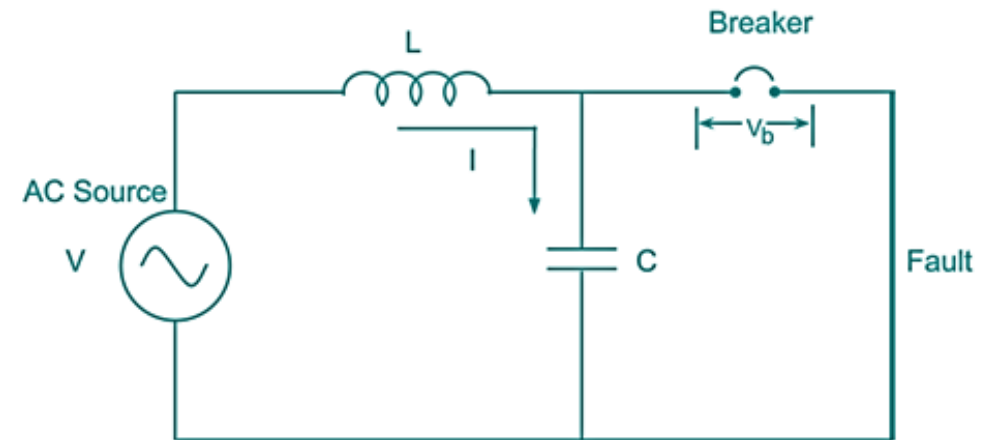

Basic Components of power systems

“Substations, circuit breaker”

- Taking Laplace Transform of both sides of the equation, we get

$$LC \frac{d^2 v_{CB}}{dt^2} + v_{CB} = V \xrightarrow{\ell} (LCs^2 + 1)V_{CB} = \frac{V}{s}$$

$$V_{CB} = \frac{V}{s} \frac{1}{(LCs^2 + 1)} = \frac{V}{LCs} \frac{1}{\left(s^2 + \frac{1}{LC}\right)}$$

$$V_{CB} = \frac{V}{s} \frac{\omega_0^2}{(s^2 + \omega_0^2)}; \quad \omega_0 = \frac{1}{\sqrt{LC}}$$

Basic Components of power systems

“Substations, circuit breaker”

- Taking the Laplace inverse, we get

$$V_{CB} = \frac{V \omega_0}{s} \frac{\omega_0}{(s^2 + \omega_0^2)} \xrightarrow{\ell^{-1}} v_{CB} = V \omega_0 \int_0^t (\sin(\omega_0 t)) dt$$

$$v_{CB} = V (1 - \cos(\omega_0 t))$$

- RRRV is given by:

$$RRRV = \frac{dv_{CB}}{dt} = \omega_0 V \sin(\omega_0 t)$$

$$(RRRV)_{\max} = \omega_0 V$$

Basic Components of power systems “Substations, circuit breaker”

- Expression of maximum value of RV and corresponding time:
 - Now

$$v_{CB} = V [1 - \cos(\omega_0 t)]$$

- If v_{CB} is to be maximum

$$\cos(\omega_0 t_m) = -1 \Rightarrow \omega_0 t_m = \pi$$

$$t_m = \frac{\pi}{\omega_0} = \pi \sqrt{LC}$$

- and the peak value of recovery voltage

$$v_{CB, \max} = 2V$$

Basic Components of power systems

“Substations, circuit breaker”

Example

For a 132 kV system, the reactance and capacitance up to the location of the circuit breaker is 3 ohms and 0.015 μF , respectively. Calculate the following:

- a) The frequency of transient oscillation.
- b) The maximum value of recovery voltage across the contacts of the circuit breaker.
- c) The maximum value of RRRV

Basic Components of power systems “Substations, circuit breaker”

Solution

$$a) \cdot f_0 = \frac{1}{2\pi\sqrt{LC}} = \frac{1}{\sqrt{\frac{3}{2\pi \times 50} \times 0.015 \times 10^{-6}}} = 13.291 \text{ kHz}$$

$$b) \cdot v_{CB, \max} = 2V = 2\sqrt{\frac{2}{3}} \times 132 = 215.56 \text{ kV}$$

$$c) \cdot (RRRV)_{\max} = \omega_0 V = 2\pi \times 13.291 \times 10^3 \times \sqrt{\frac{2}{3}} \times 132 \times 10^3 = 9 \text{ kV}/\mu\text{s}$$

Basic Components of power systems

“Substations, circuit breaker”



- To reduce the recovery voltage, RRRV and severity of the transient oscillations, a resistance is connected across the contacts of the circuit breaker.
- This is known as resistance switching. The resistance is in parallel with the arc. A part of the arc current flows through this resistance resulting in a decrease in the arc current and increase in the deionization of the arc path and resistance of the arc.
- This process continues and the current through the shunt resistance increases and arc current decreases. Due to the decrease in the arc current, TRV and RRRV are reduced.

Basic Components of power systems

“Substations, circuit breaker”

- The resistance may be automatically switched in with the help of a sphere gap.
- The resistance switching is of great help in switching out capacitive current or low inductive current.
- The analysis of resistance switching can be made to find out the critical value of the shunt resistance to obtain complete damping of transient oscillations.

Basic Components of power systems

“Substations, circuit breaker”

- By applying KVL in the loop, we get

$$v_s = L \frac{di_L}{dt} + v_{CB}; \quad i_L = i_C + i_R;$$

$$i_R = \frac{v_{CB}}{R}; \quad i_C = C \frac{dv_{CB}}{dt}$$

where v_s is the system voltage at the instant of arc interruption. As the transient oscillation is a fast phenomenon, v_s can be regarded as a constant for a short duration.

Basic Components of power systems

“Substations, circuit breaker”

$$v_s = L \frac{d(i_C + i_R)}{dt} + v_{CB} = L \frac{d}{dt} \left(C \frac{dv_{CB}}{dt} + \frac{v_{CB}}{R} \right) + v_{CB} \approx V$$

$$v_s = LC \frac{d^2 v_{CB}}{dt^2} + \frac{L}{R} \frac{dv_{CB}}{dt} + v_{CB} \approx V$$

- Taking Laplace transform of both sides of the equation, we get

$$LC \frac{d^2 v_{CB}}{dt^2} + \frac{L}{R} \frac{dv_{CB}}{dt} + v_{CB} = V \xrightarrow{\ell} (LCs^2 + (L/R)s + 1)V_{CB} = \frac{V}{s}$$

$$V_{CB} = \frac{V}{s} \frac{1}{(LCs^2 + (L/R)s + 1)} = \frac{V}{LCs} \frac{1}{(s^2 + (1/RC)s + (1/LC))}$$

Basic Components of power systems

“Substations, circuit breaker”

- Characteristic equation:

$$s \left(s^2 + \frac{1}{RC} s + \frac{1}{LC} \right) = 0$$

- Roots of the characteristic equation:

$$s_1 = 0$$

$$s_{2,3} = -\alpha \mp \sqrt{\alpha^2 - \omega_0^2}; \quad \alpha = \frac{1}{2RC} \quad \omega_0 = \frac{1}{\sqrt{LC}}$$

Basic Components of power systems

“Substations, circuit breaker”

- For no transient oscillation (overdamped response), all the roots of the equation should be real. One root is zero, i.e. $s_1 = 0$ which is real. For the other two roots to be real, the roots of the quadratic equation in the denominator should be real. For this, the following condition should be satisfied.

$$\alpha \geq \omega_0 \Rightarrow \frac{1}{2RC} \geq \frac{1}{\sqrt{LC}}$$

$$R \leq \frac{1}{2} \sqrt{\frac{L}{C}} = R_c$$

Basic Components of power systems

“Substations, circuit breaker”

- Therefore, if the value of the resistance connected across the contacts of the circuit breaker is equal to or less than R_c there will be no transient oscillation.

$R = R_c \rightarrow$ critically damped

$R > R_c \rightarrow$ under damped

$R < R_c \rightarrow$ over damped

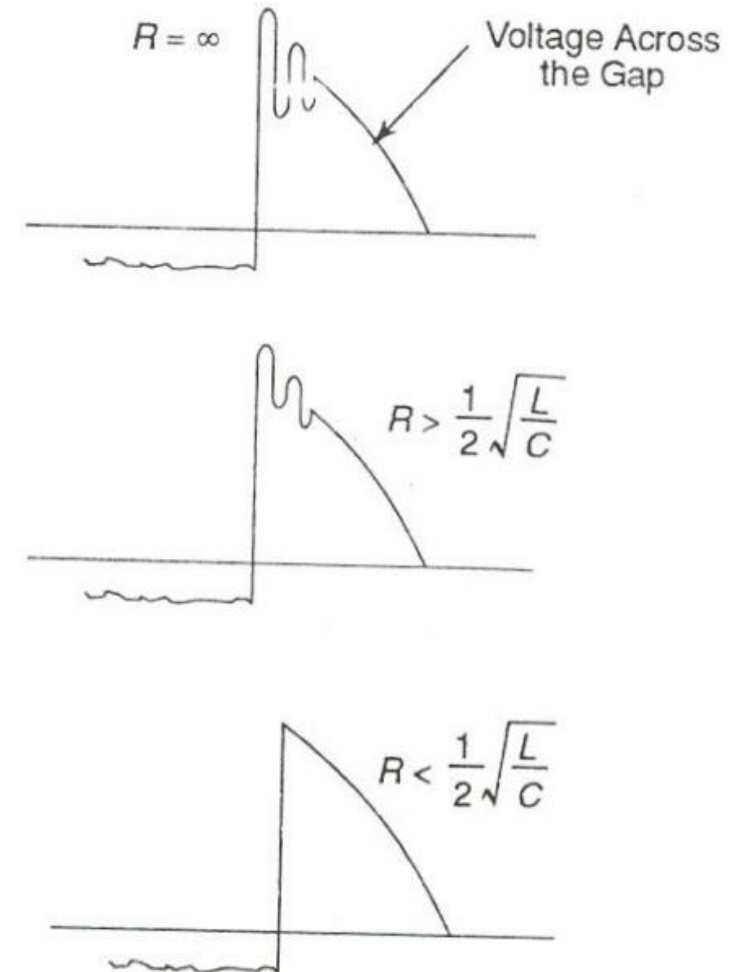

Basic Components of power systems

“Substations, circuit breaker”

Example

In a 220 kV system, the reactance and capacitance up to the location of circuit breaker is 8 ohms and $0.025 \mu\text{F}$, respectively. A resistance of 600 ohms is connected across the contacts of the circuit breaker. Determine the following:

- a) Natural frequency of oscillation.
- b) Damped frequency of oscillation.
- c) Critical value of resistance which will give no transient oscillation.
- d) The value of resistance which will give damped frequency of oscillation, one-fourth of the natural frequency of oscillation.

Basic Components of power systems “Substations, circuit breaker”

Solution

a)

$$f_0 = \frac{1}{2\pi\sqrt{LC}}$$

$$f_0 = \frac{1}{\sqrt{\frac{8}{2\pi \times 50} \times 0.025 \times 10^{-6}}} = 6.304 \text{ kHz}$$

Basic Components of power systems

“Substations, circuit breaker”

Solution

b)

$$f_d = \frac{1}{2\pi} \sqrt{\omega_0^2 - \alpha^2} = \frac{1}{2\pi} \sqrt{\frac{1}{LC} - \left(\frac{1}{2RC}\right)^2}$$

$$f_d = \frac{1}{2\pi} \sqrt{\frac{1}{\frac{8}{2\pi \times 50} \times 0.025 \times 10^{-6}} - \left(\frac{1}{2 \times 600 \times 0.025 \times 10^{-6}}\right)^2} = 3.413 \text{ kHz}$$

Basic Components of power systems “Substations, circuit breaker”

Solution

c)

$$R_c = \frac{1}{2} \sqrt{\frac{L}{C}}$$

$$R_c = \frac{1}{2} \sqrt{\frac{\left(\frac{8}{2\pi \times 50}\right)}{0.025 \times 10^{-6}}} = 504.35 \Omega$$

Basic Components of power systems

“Substations, circuit breaker”

Solution

$$d) \quad f_d = \frac{1}{2\pi} \sqrt{\omega_0^2 - \alpha^2} = \frac{1}{2\pi} \sqrt{\frac{1}{LC} - \left(\frac{1}{2RC}\right)^2} = \frac{1}{4} \frac{1}{2\pi} \frac{1}{\sqrt{LC}}$$

$$\frac{1}{LC} - \left(\frac{1}{2RC}\right)^2 = \frac{1}{16LC} \Rightarrow \left(\frac{1}{2RC}\right)^2 = \frac{15}{16LC}$$

$$\frac{1}{RC} = \frac{\sqrt{15}}{2\sqrt{LC}} \Rightarrow R = 2\sqrt{\frac{L}{15C}} = 2\sqrt{\frac{\left(\frac{8}{2\pi \times 50}\right)}{15 \times 0.025 \times 10^{-6}}} = 521.17 \, \Omega$$

Basic Components of power systems

“Substations, circuit breaker”

- The rated transient recovery voltage (TRV) is the peak transient voltage (expressed in kV) that corresponds to the first pole-to-clear when interrupting a three-phase fault at rated short-circuit current.
- The rated transient recovery voltage (V_{TRV}) is calculated as follows (based on IEC):

$$V_{TRV} = \sqrt{\frac{2}{3}} k_{pp} k_{af} V_r,$$

where V_r is the rated line voltage in kV, k_{pp} is the first pole-to-clear factor, and k_{af} is the amplitude factor

Basic Components of power systems

“Substations, circuit breaker”

- Definition of first-pole-to-clear factor:

It is the ratio of the power-frequency voltage across the first interrupting pole before current interruption in the other poles, to the power-frequency voltage occurring across the pole or the poles after interruption in all three poles.

It is the ratio between the recovery voltage across the first pole to clear and the phase to ground voltage of the system.

$$k_{pp} = \frac{\text{Recovery voltage on the first pole}}{V_r / \sqrt{3}}$$

Basic Components of power systems

“Substations, circuit breaker”

- One of the circuit-breaker poles will be the first to encounter a current zero and if the interruption is successful, this pole is called *first-pole-to-clear*.
- The first-pole-to-clear-factor (k_{pp}) is depending on the earthing of the network.
- Neutral-system earthing:
 - Solidly earthed,
 - Effectively earthed,
 - Non-effectively earthed.
- The first-pole-to-clear-factor is used for calculating the transient recovery voltage for three-phase faults.

Basic Components of power systems

“Substations, circuit breaker”

- In general the following cases apply:

$k_{pp} = 1.3$ corresponds to three-phase faults in systems with an effectively earthed neutral.

$k_{pp} = 1.5$ corresponds to three-phase faults in non-effectively earthed systems.

$k_{pp} = 1.0$ corresponds to special cases, e.g. two-phase railway systems, short-line fault.

- A special case is when there is a three-phase fault without involving earth. This case corresponds to $k_{pp} = 1.5$. This case is covered by the IEEE standards.

Basic Components of power systems

“Substations, circuit breaker”

- The current in the first-pole-to-clear is interrupted ($i_1 = 0$), causing the current in the two other phases to become equal in magnitude and opposite in polarity. The two-phase currents i_2 and i_3 can be calculated easily as:

$$i_2 = \frac{u_2 - u_3}{2X_1} = -i_3,$$

where X_1 is the short-circuit reactance of each of the phases, and u_2 , u_3 are the phase-to-earth voltages of the source.

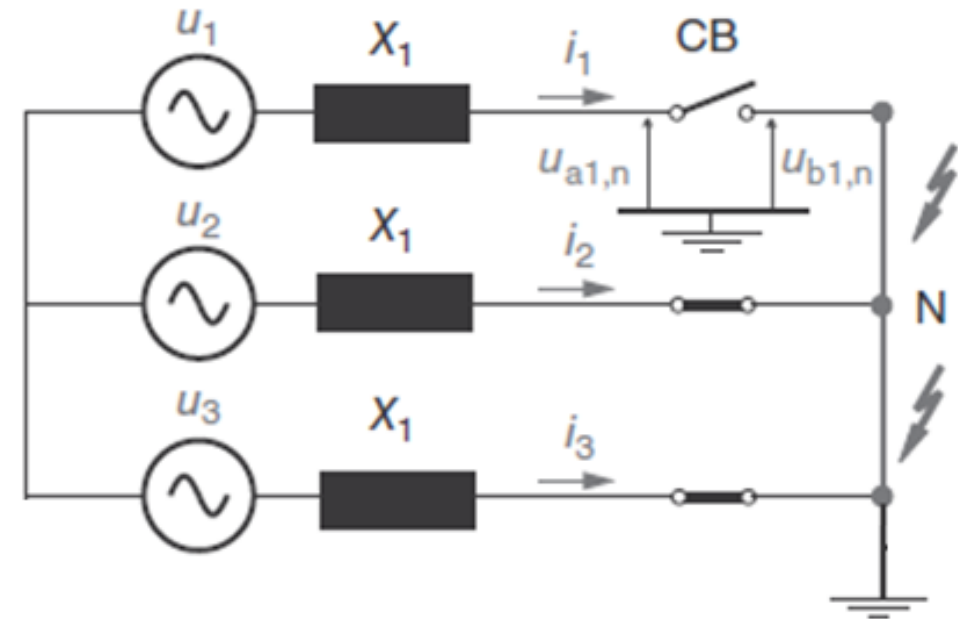

Three-phase faults in non-effectively earthed systems

Basic Components of power systems

“Substations, circuit breaker”

- The voltage across the circuit-breaker can be calculated in the following way:

$$u_2 - X_1 i_2 = u_{b1,n}, \quad u_3 + X_1 i_2 = u_{b1,n}$$

$$u_{a1,b1} = u_{a1,n} - u_{b1,n} = u_1 - \left(\frac{u_2 + u_3}{2} \right) = u_1 - \left(\frac{-u_1}{2} \right),$$

$$u_{a1,b1} = 1.5u_1$$

$$k_{pp} = \frac{u_{a1,b1}}{u_1} = 1.5$$

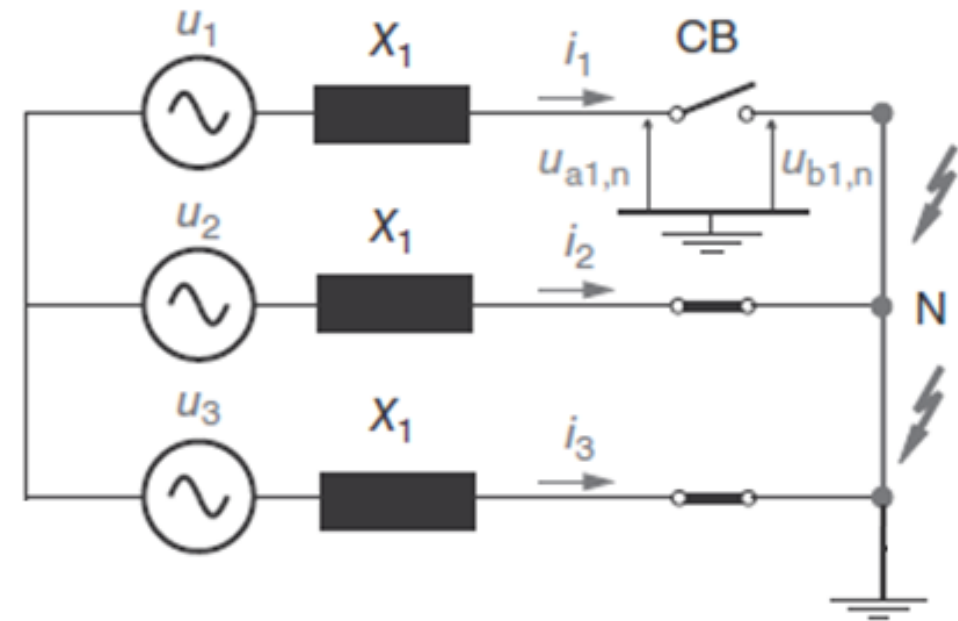

Basic Components of power systems

“Substations, circuit breaker”

- The second- and third-pole-to-clear interrupt at the same instant and will share a recovery voltage of $u\sqrt{3}$, equal to the phase-to-phase or line voltage imposed across the series combination of both circuit-breakers.
- Thus, assuming equal voltage distribution across each of the circuit-breakers, each pole recovers against a momentary recovery voltage of $0.5 u\sqrt{3}$, having an amplitude of 0.87 p.u. at last-poles current zero in a pure inductive case. After interruption of the last two poles, the RV across all poles is restored to 1 p.u.

Basic Components of power systems

“Substations, circuit breaker”

The current-interruption process

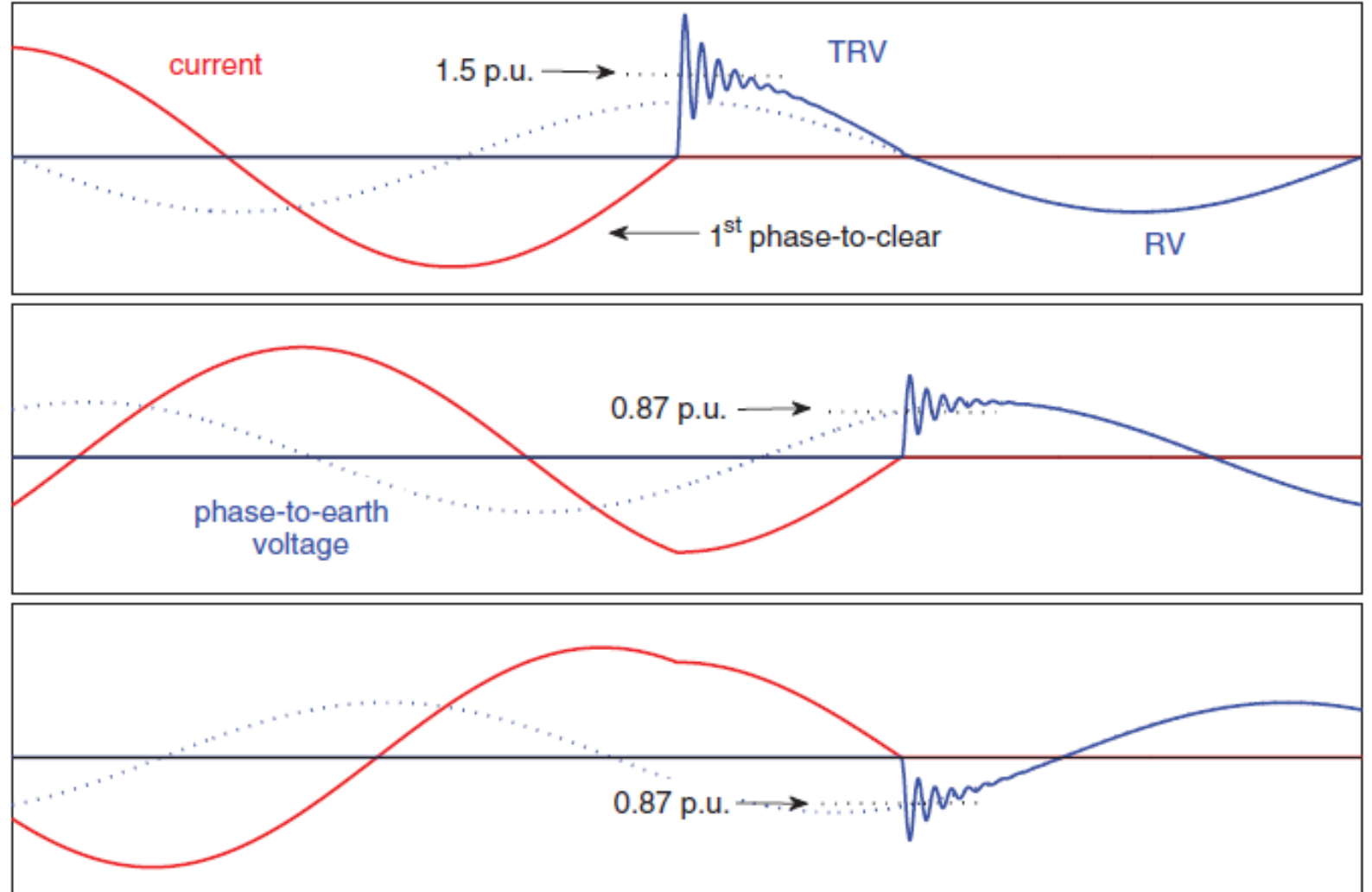

Basic Components of power systems

“Substations, circuit breaker”

- The CB has two main settings: *tap setting* and *time dial setting*.
- The tap setting determines the level of current above which the CB is to open.
- Since most faults are temporary and can be cleared by themselves, the breakers are designed to wait a while before they initiate the opening. This delay time is the time dial setting.

Basic Components of power systems

“Substations, circuit breaker”

- Main characteristics of CB:

- Tripping or breaking time

Tripping time = opening time + arcing time

Opening time: it is the time between the instant of application of tripping power to the instant of separation of main contacts.

Arcing time: it is the time between the instant of separation of main contacts to the instant of arc extinction.

Basic Components of power systems

“Substations, circuit breaker”

➤ Rapturing or breaking capacity

It is the capacity of the CB that the main contacts are capable of interrupting, it is expressed in kVA

$$\text{Rapturing capacity of CB} = \sqrt{3} V_L I_F$$

where I_F is the fault current and V_L is the system volts

Note: the selection of breaking capacity depends on the fault conditions expected in the system

Basic Components of power systems

“Substations, circuit breaker”



Typical rupturing capacities
of modern circuit breakers

kV	MVA	kA
3.3	50	8.8
	75	13.1
	150	26.3
6.6	150	13.1
	250	21.9
	350	31.5
11.0	150	7.9
	250	13.1
	500	26.3
	750	40.0
33.0	500	8.8
	750	13.1
	1500	26.3
66.0	1500	13.1
	2500	21.9

Basic Components of power systems

“Substations, circuit breaker”

- Types of faults:
 - Transient (80%): lightning, arc flash
 - Semi-permanent (13%): animals and branches on line
 - Permanent (7%): line and pole damages

Basic Components of power systems

“Substations, circuit breaker”

- Another type of CB commonly used in distribution networks is the *recloser*.
- They are CBs with built-in instrument transformers and relays
- They are available for 2.4-46 kV systems
- Reclosers are less expensive types of CBs with lower current ratings and slower action than substation CBs.
- They can interrupt fault currents and can automatically reclose after a momentary outage. However, if the fault is permanent, the recloser locks itself in the open position after a preset number of reclosing operations occur.

Basic Components of power systems “Substations, circuit breaker”



SF6 CB

Basic Components of power systems

“Substations, disconnecting switches”

- DSs are automatic or manually operating devices.
- In either case, they are not designed to interrupt a fault current and are less precise than CBs.
- They are normally used to isolate sections of the network.
- For example, the CB has one DS on each side to allow workers to perform maintenance on the CB.
- The CB is first opened to interrupt the current. Then, the two DS are opened to isolate the CB from the grid..

Basic Components of power systems

“Substations, disconnecting switches”

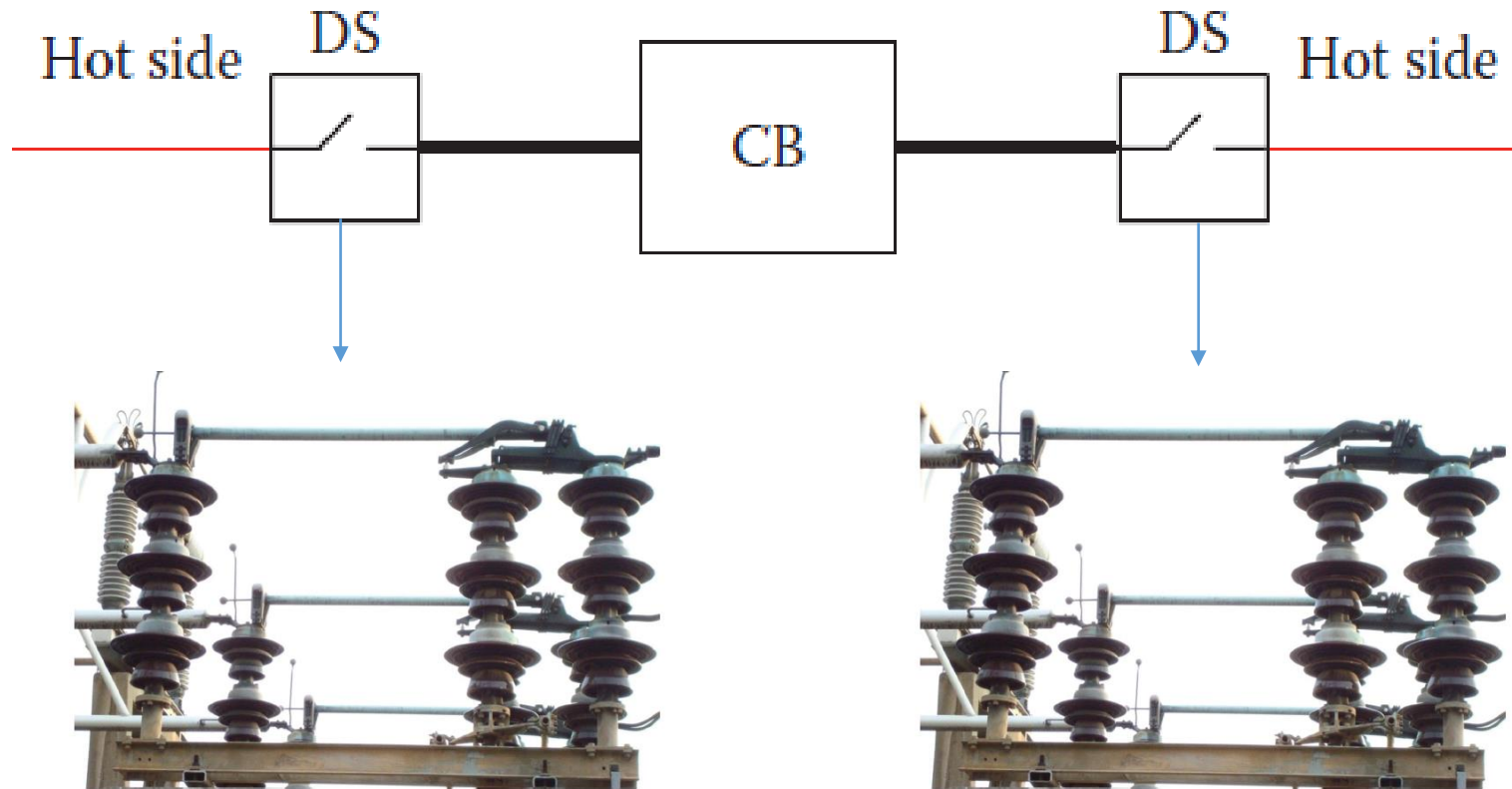

Basic Components of power systems

“Substations, sectionlizer”

- Another type of DS is the sectionalizer.
- This device is more sophisticated than the DS described earlier.
- Sectionalizers do not interrupt fault currents and are often used in conjunction with reclosers.
- They have counters that keep track of the number of times a recloser operates and can isolate sections of the network when the power is off.

Basic Components of power systems

“Substations, sectionlizer”

- The figure shows a recloser after the distribution transformer.
- Loads 1–3 are served by the recloser.
- A sectionalizer is installed between Loads 2 and 3.
- Assume that the recloser is designed to operate twice (two counts) and the sectionalizer is designed to operate once (one count).

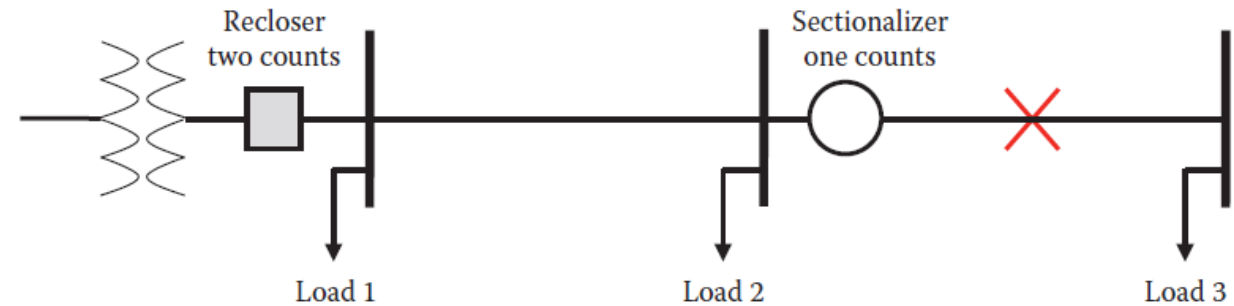

Basic Components of power systems “Substations, sectionalizer”

- Assume a fault occurs in the line between Loads 2 and 3.
- The fault causes the recloser to open.
- The sectionalizer notices that the recloser is open. Assume that the fault is not cleared and the recloser is closed into the fault.
- The recloser will quickly open again as the fault is still there.

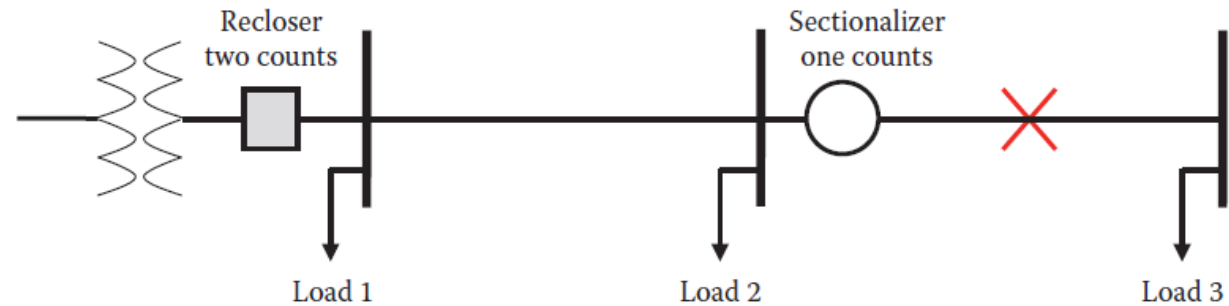

Basic Components of power systems “Substations, sectionalizer”

- The sectionalizer will know that the recloser is opened the second time. This is when the sectionalizer opens its contacts.
- The next time the recloser closes the circuit, there is no fault seen by the recloser and Loads 1 and 2 are served.
- Because of this coordination, when the fault is permanent, we can isolate the section of the network with the fault and serve the rest of the customers.

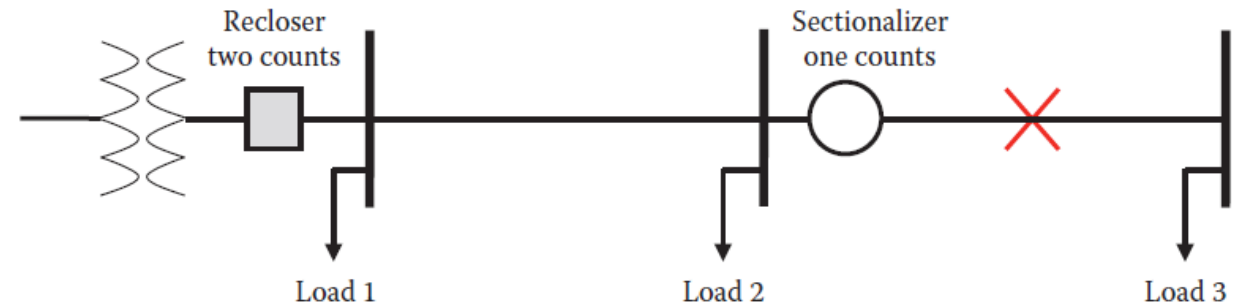

Basic Components of power systems

“Substations, surge arrester”

- Switching of power lines and lightning strikes can cause excessive and sudden increase in voltage at the substations.
- This can lead to extensive damage to the insulation material inside expensive equipment such as transformers, insulators, CTs, and PTs.
- It can also cause arcing between components, leading to equipment failures.
- When a lightning strike reaches oil-immersed equipment, the heat produced by the lightning energy increases the pressure inside its housing.
- If the pressure reaches a high enough level, the housing could burst and an incredible fire could follow.

Basic Components of power systems

“Substations, surge arrester”

- What makes this problem more severe is the fact that lightning is a wave that travels along the line at the speed of light. So when it is detected, it is often too late to react.
- To protect the vulnerable equipment, *surge (or lightning) arresters* are used in substations. These devices operate very similarly to the zener diode whose resistance is inversely proportional to the applied voltage.

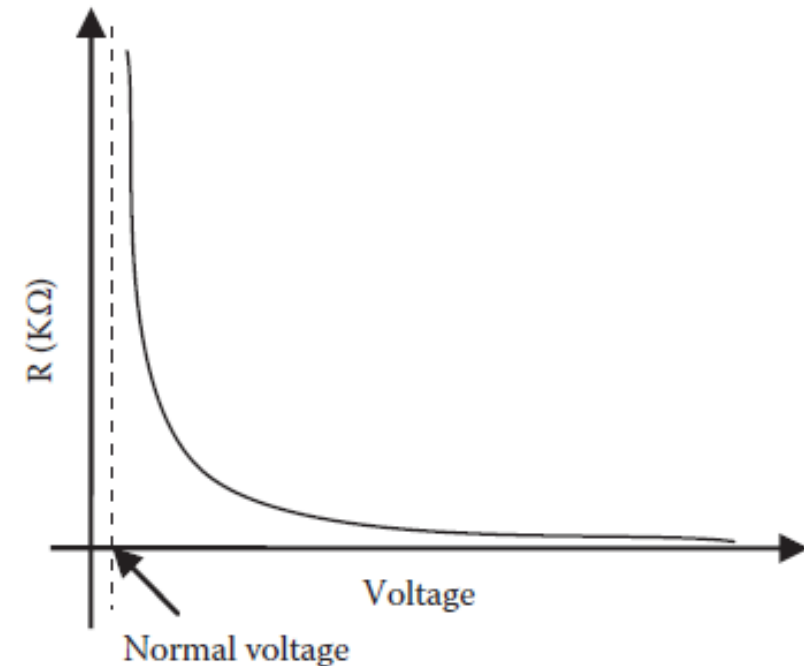

Resistance of surge arrester as function of applied voltage.

Basic Components of power systems

“Substations, surge arrester”

- The surge arrester used in substations is often made of metal-oxide disks inside porcelain housing and is called **metal-oxide varistor (MOV)**.
- The term “varistor” is a combination of two words: variable and resistor.
- The top end of the MOV is connected to the high-voltage terminal of the equipment to be protected.
- The lower end is connected to a good grounding system.
- During normal operations the arrester is seen as an open circuit due to its extremely high resistance at the nominal voltage. The line current in this case continues along the line as if the arrester does not exist.

Basic Components of power systems

“Substations, surge arrester”

- However, when lightning hits, the excessive voltage of the bolt causes the resistance of the arrester to drop substantially making the surge arrester a short circuit path for the lightning current, thus dispersing almost all the energy of the bolt into ground and protecting all devices downstream from the lightning arrester.
- In some cases, the surge arrester is mounted at the entrance of the transformer winding. In areas with potentials for lightning storms, you may find the surge arrester installed on pole transformers.

Basic Components of power systems “Substations, surge arrester”

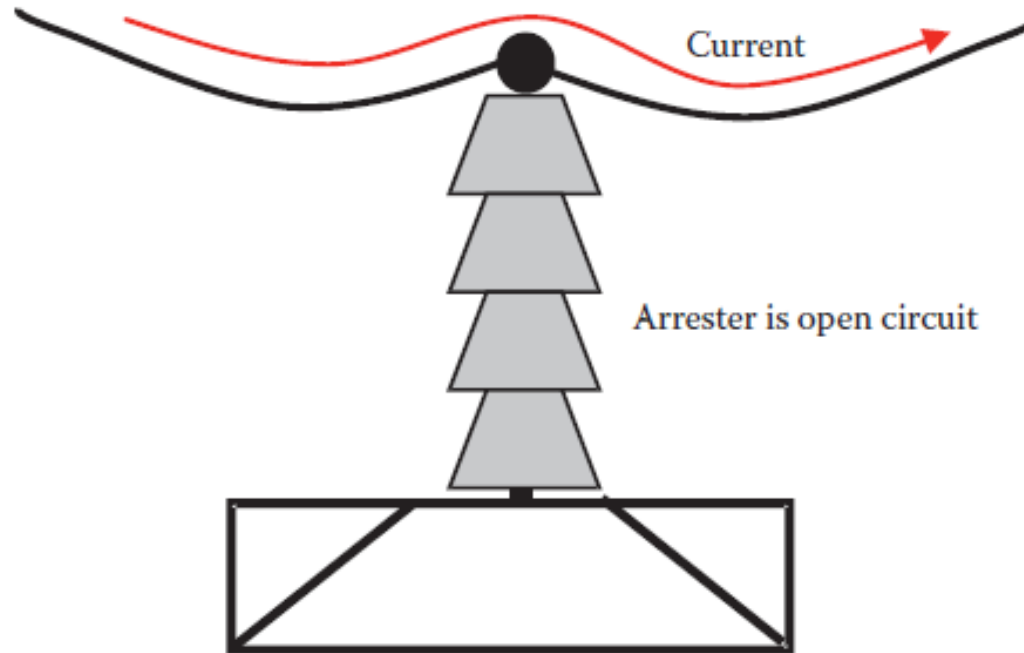

Surge arrester during normal voltage.

Basic Components of power systems “Substations, surge arrester”

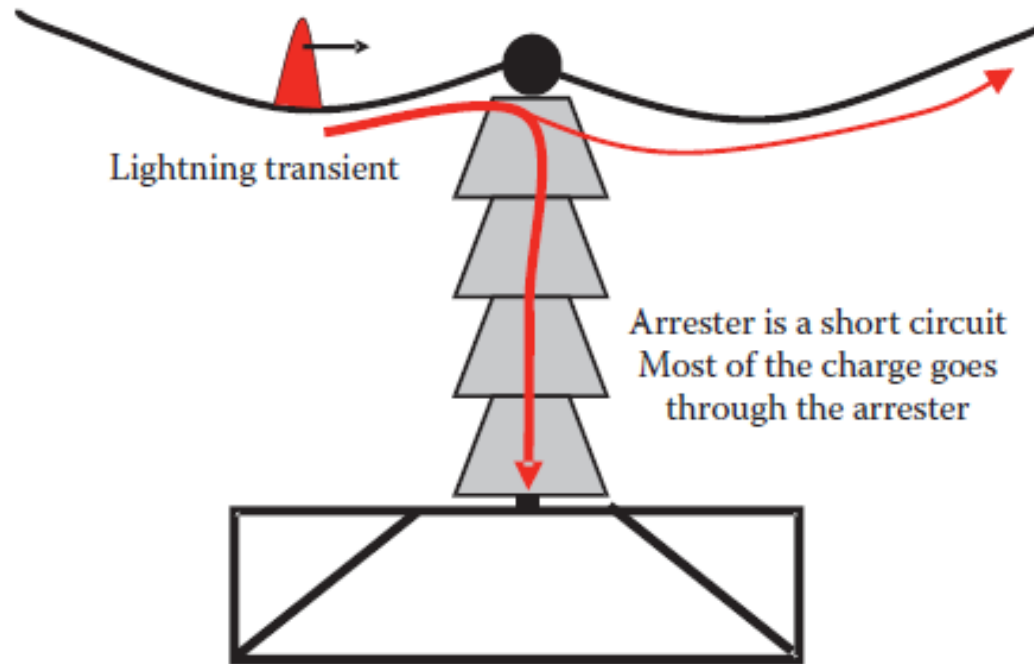

Surge arrester during surges.

Basic Components of power systems “Substations, surge arrester”

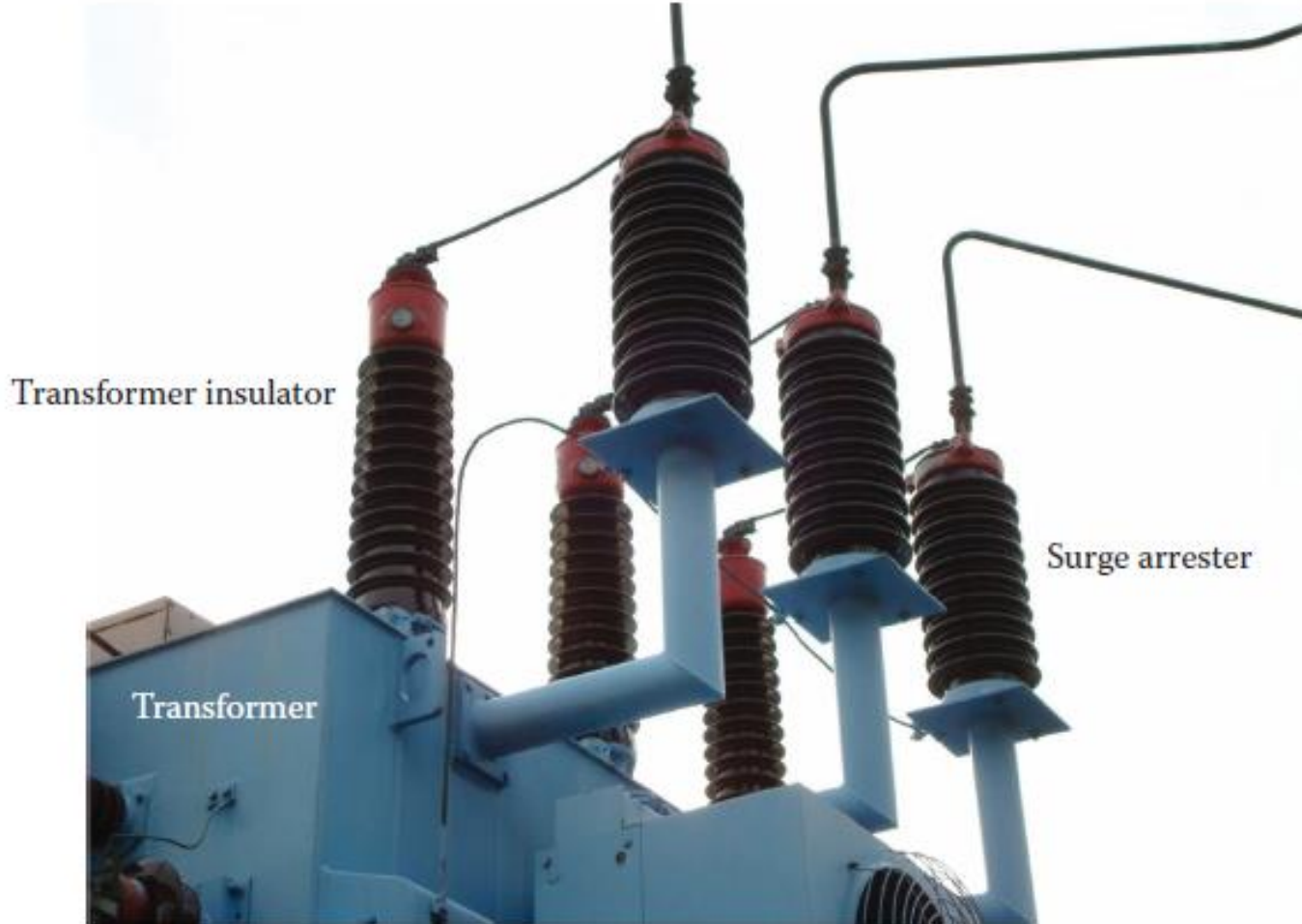

Surge arrester
mounted on
transformer.