

draw a circle that pass through the following three points

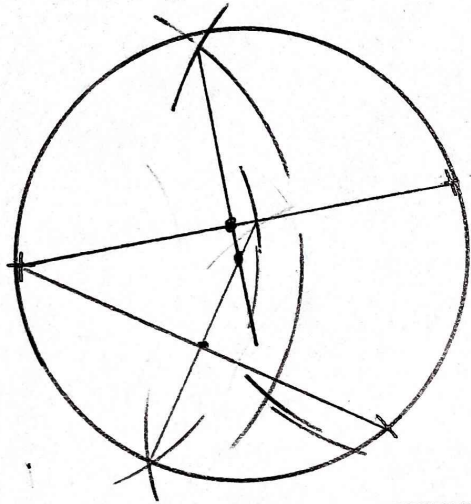

draw a circle tangent to the following two lines (R=20 mm)

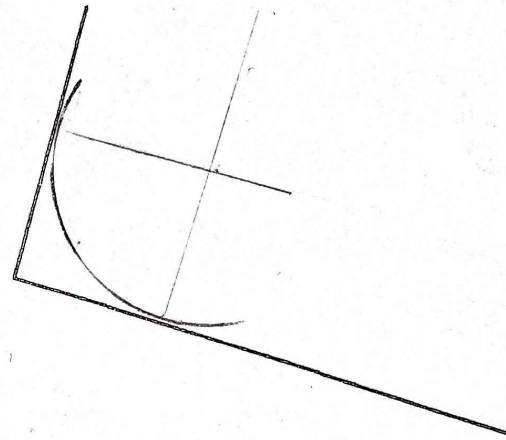

Draw a circle that pass through the point and tangent to the line (R=20)

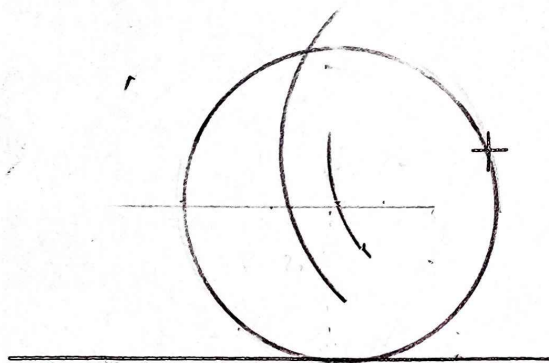

Draw a circle tangent to the following two circles (R=20mm)

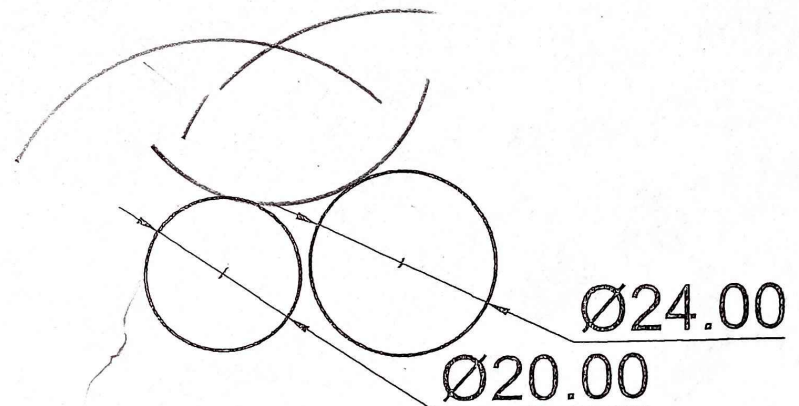

6 equally spaced

8 equally spaced

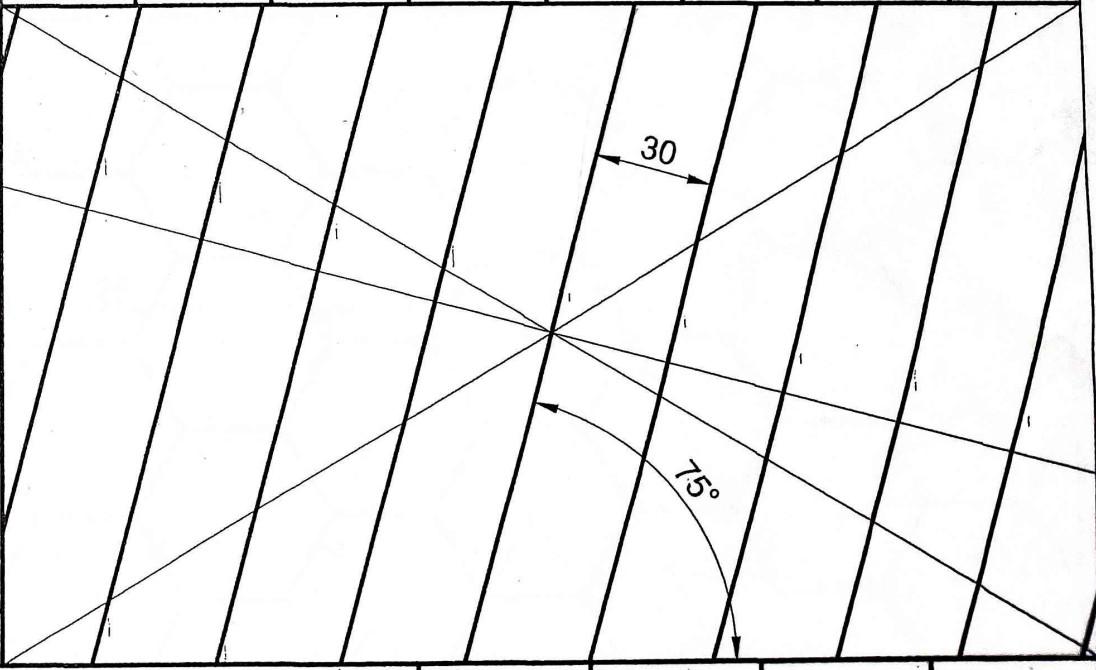
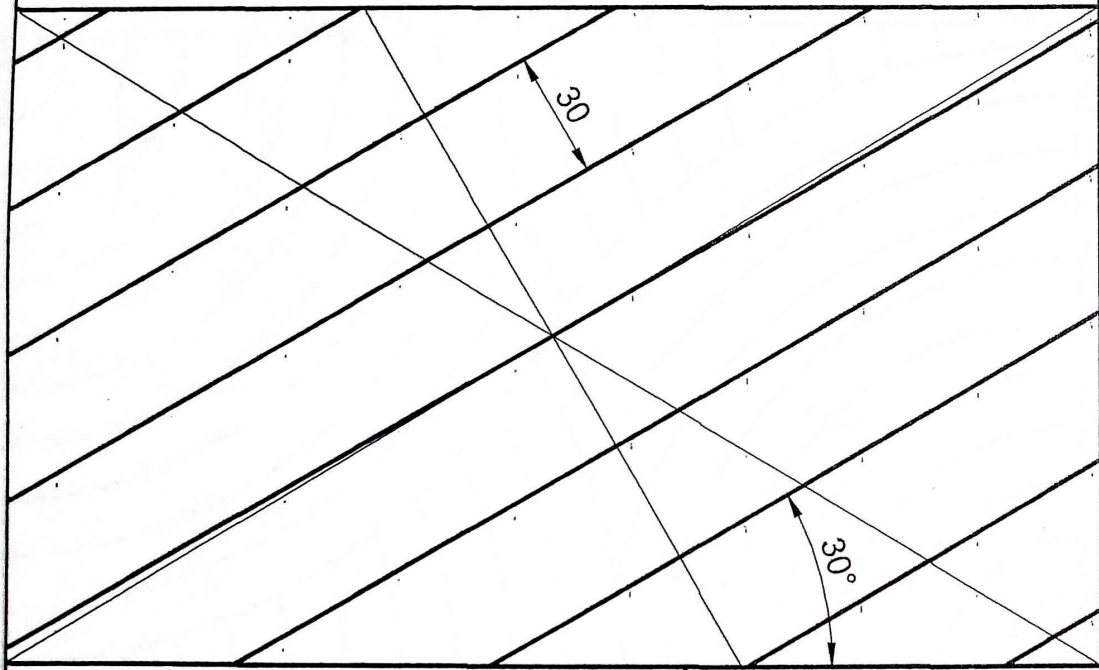

LINES

1:1

10/10 clean lines
 10/10 lettering
 10/10 lines
 34/35 accuracy
 34/35 steps

98

 100

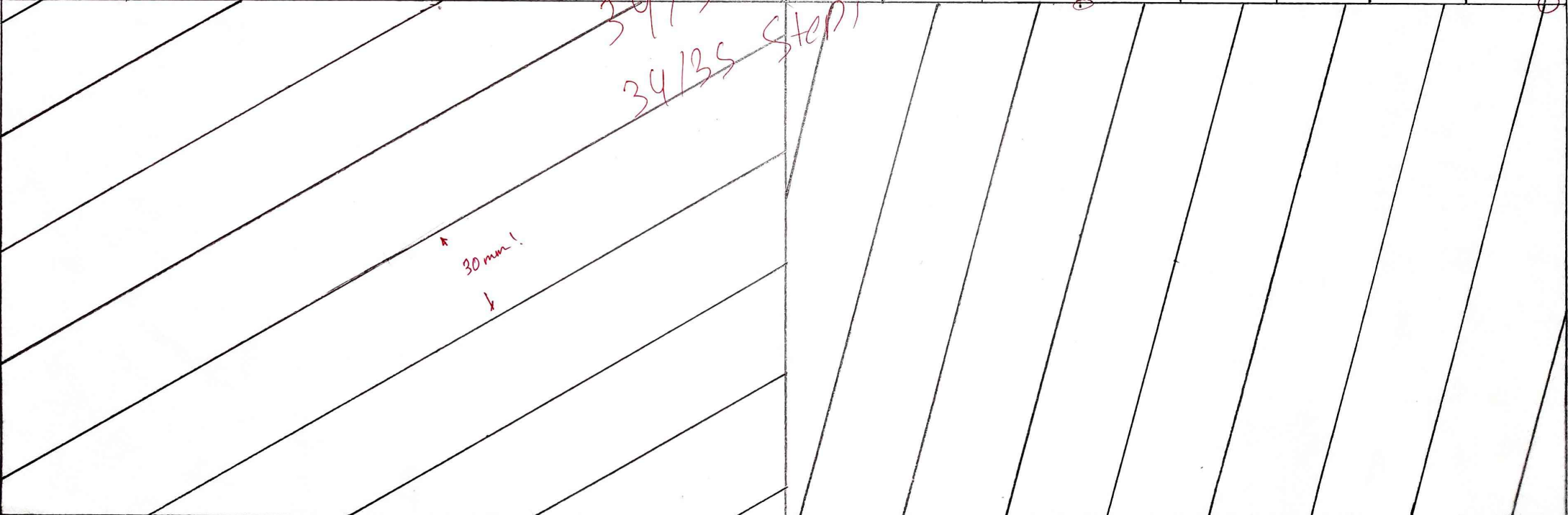

LINES

OBAYDA SARRAJ

1211128

R10

23/9/2021

1:1

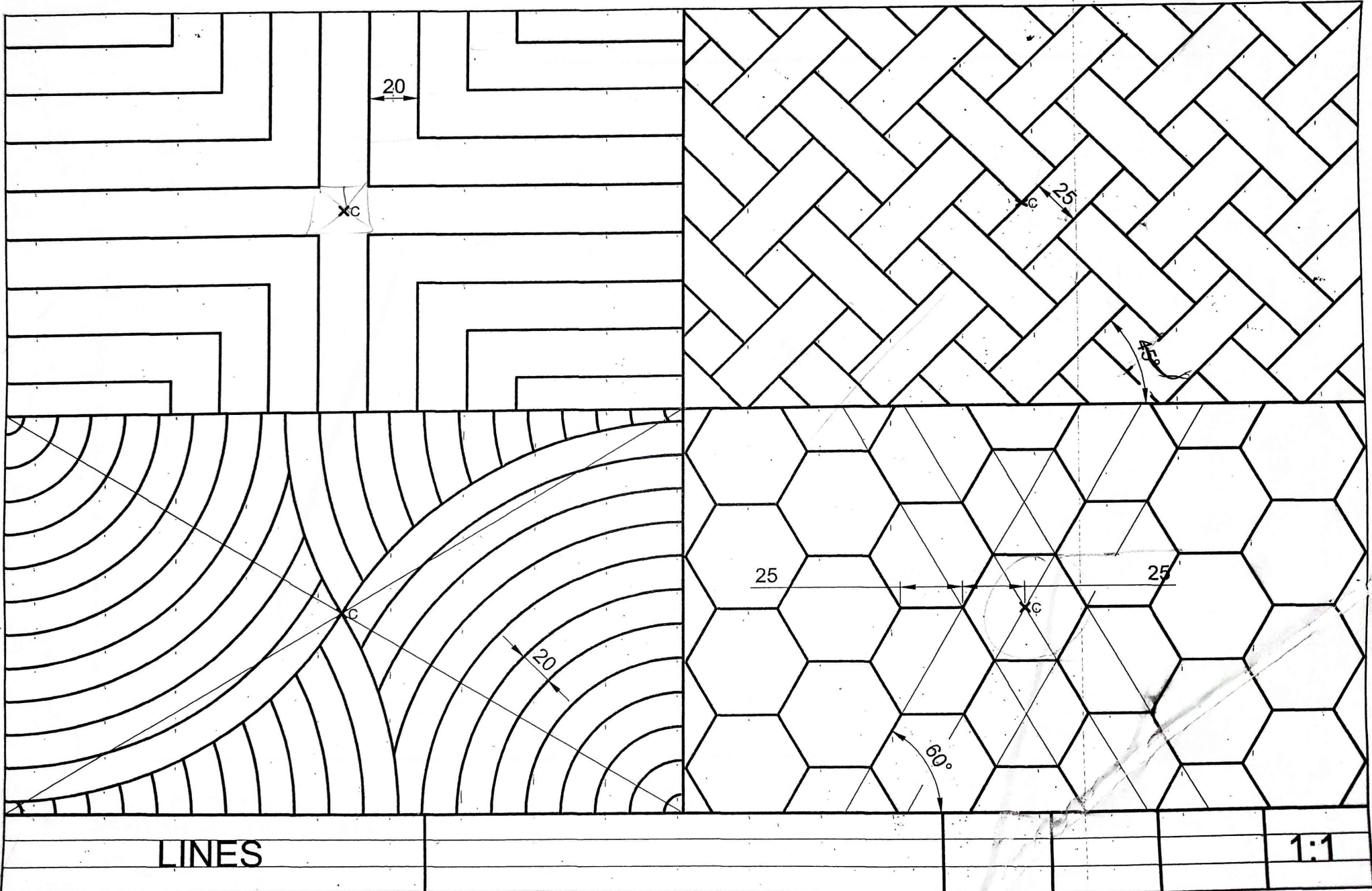

LINES

1:1

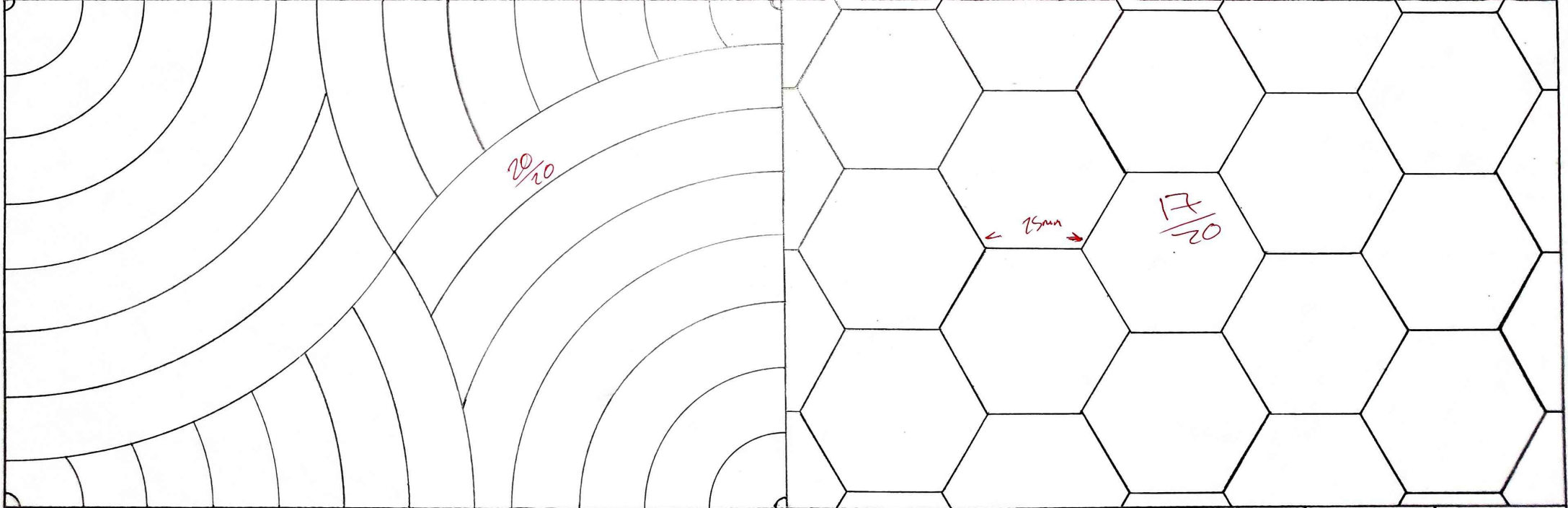
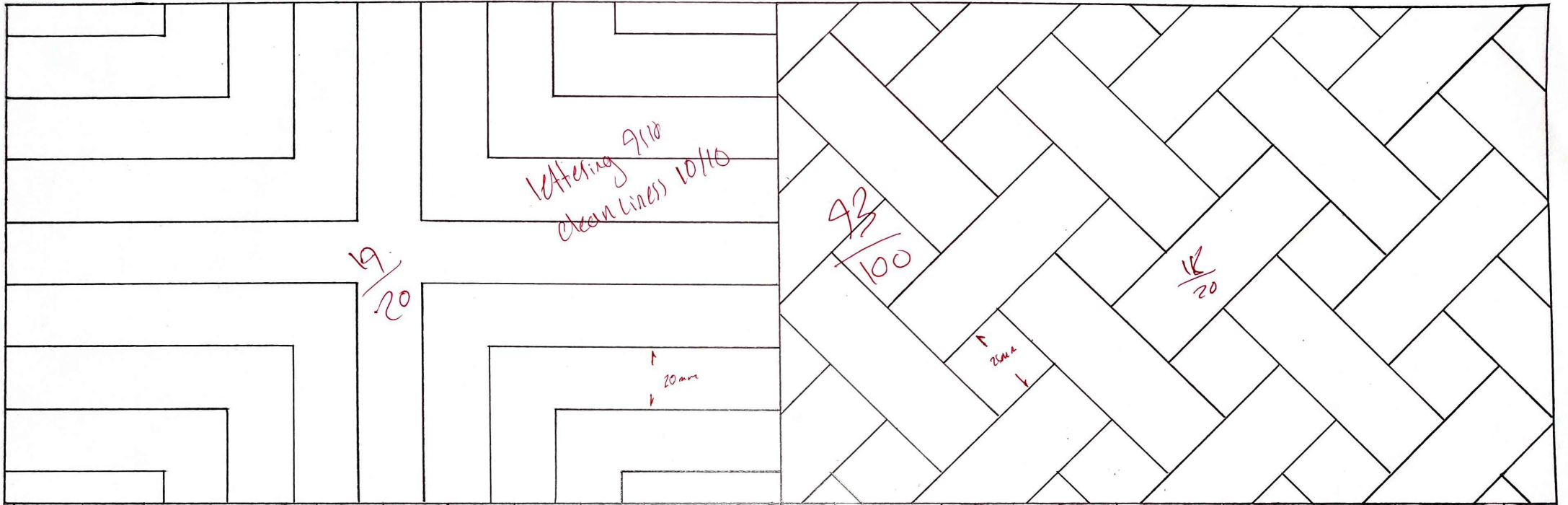

LINES	OBAYDA SARRAJ	1211128	R10	30/9/2021	1:1
-------	---------------	---------	-----	-----------	-----

Scale: 1:1
Point C: (200, 180)

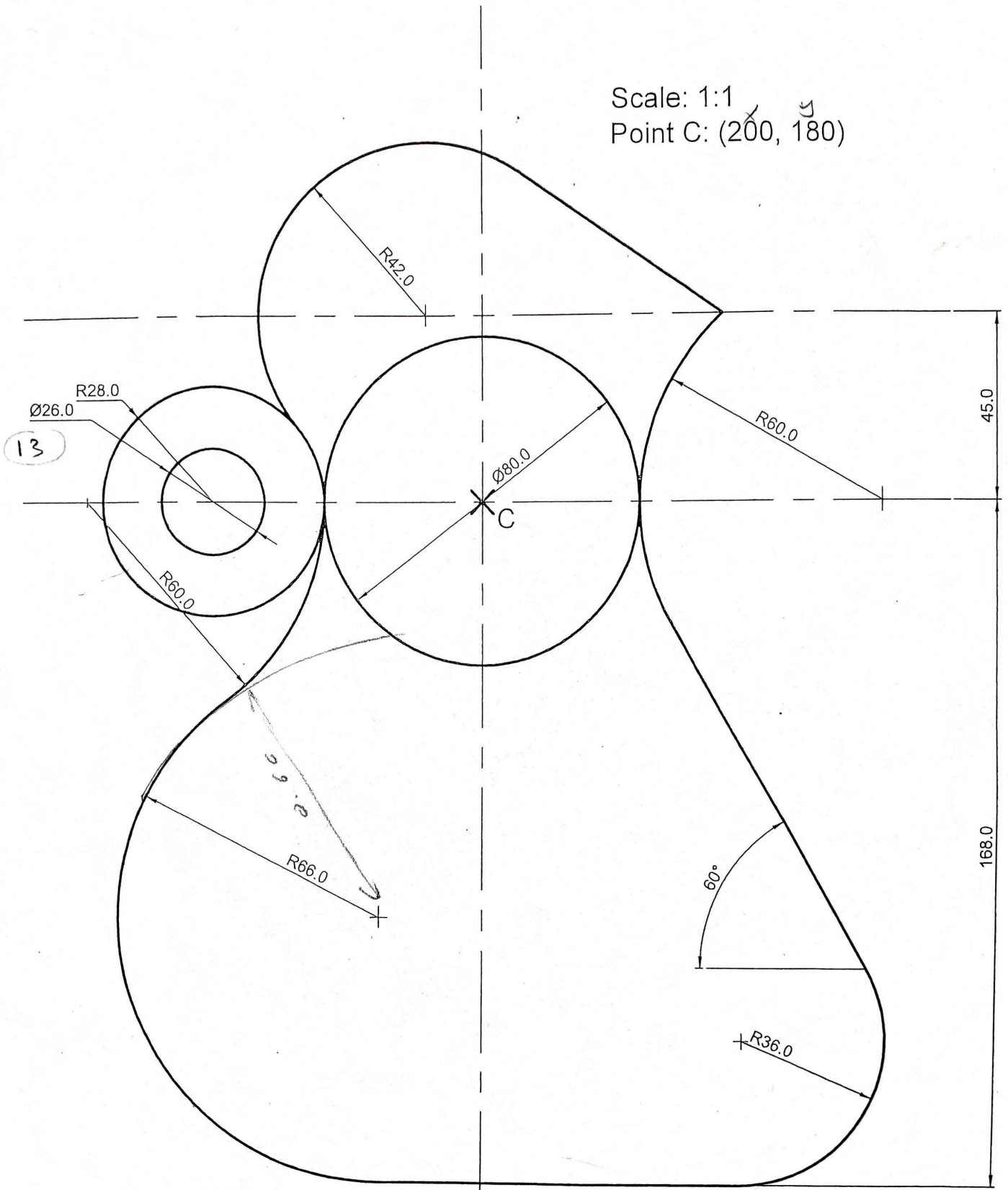

13

TANGENTS

60

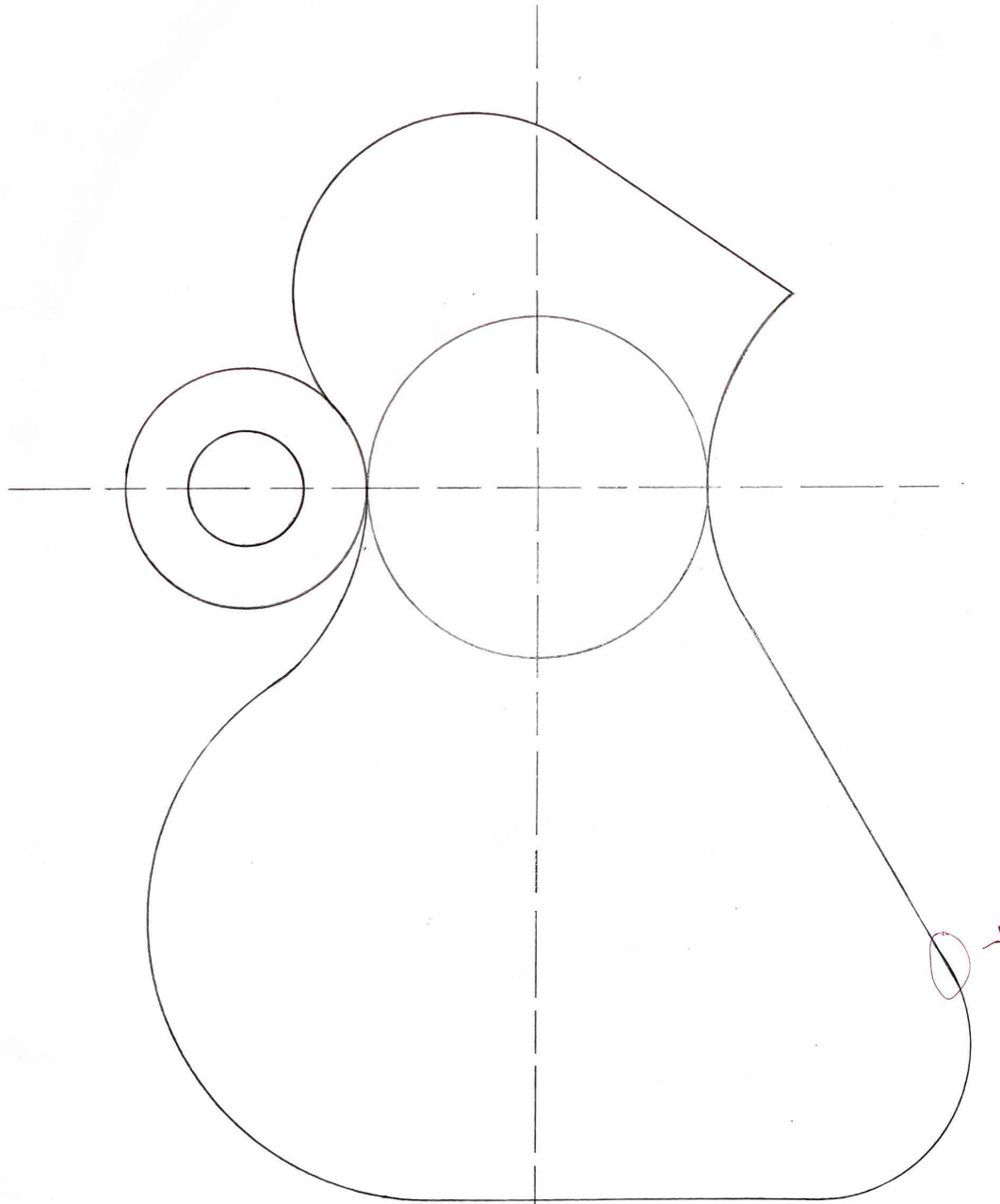

Tangents 14/150
 circle 15/15
 lines 15/15
 C+L 19/20

98
 100

Scale 2:1
Point C: (70, 140)

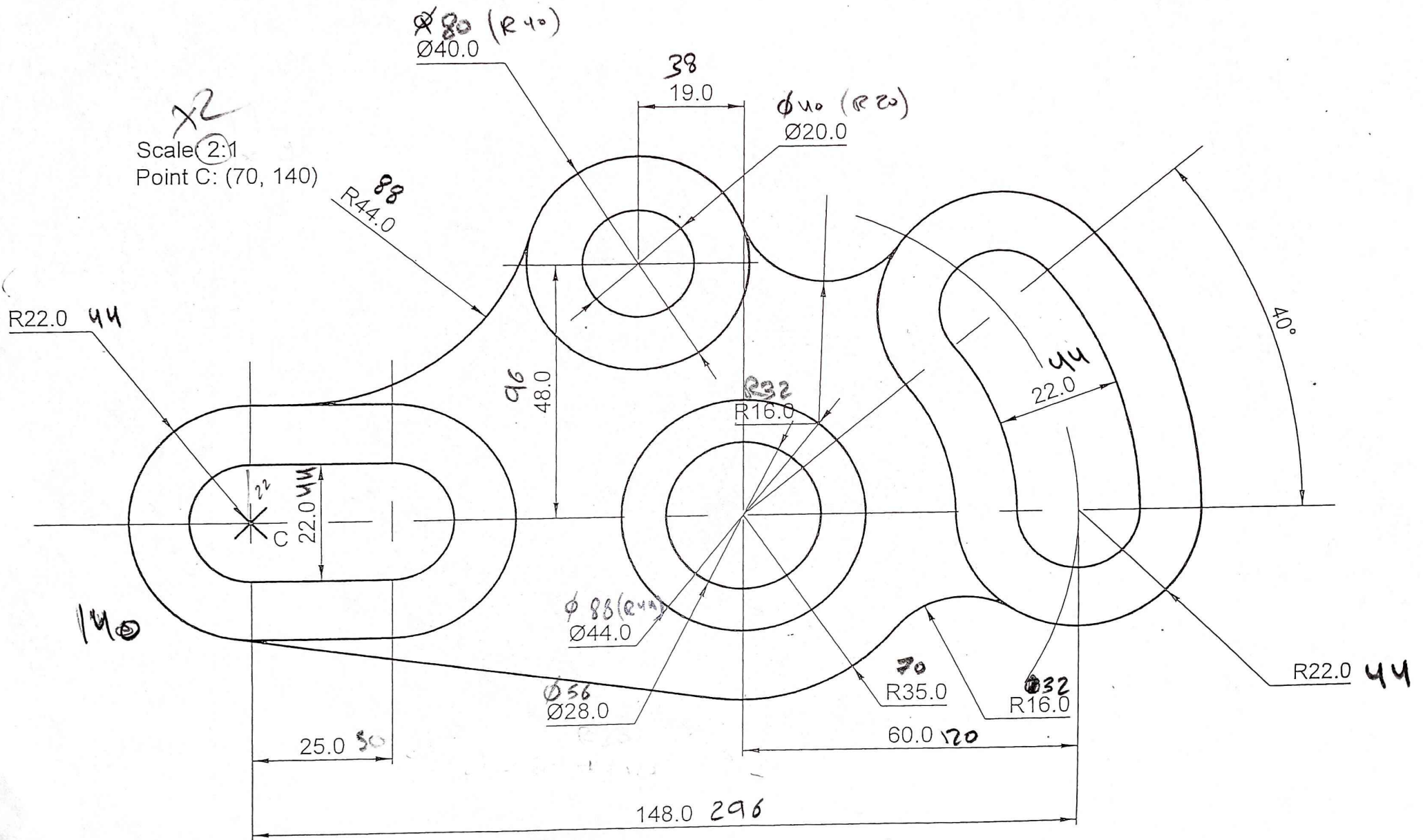

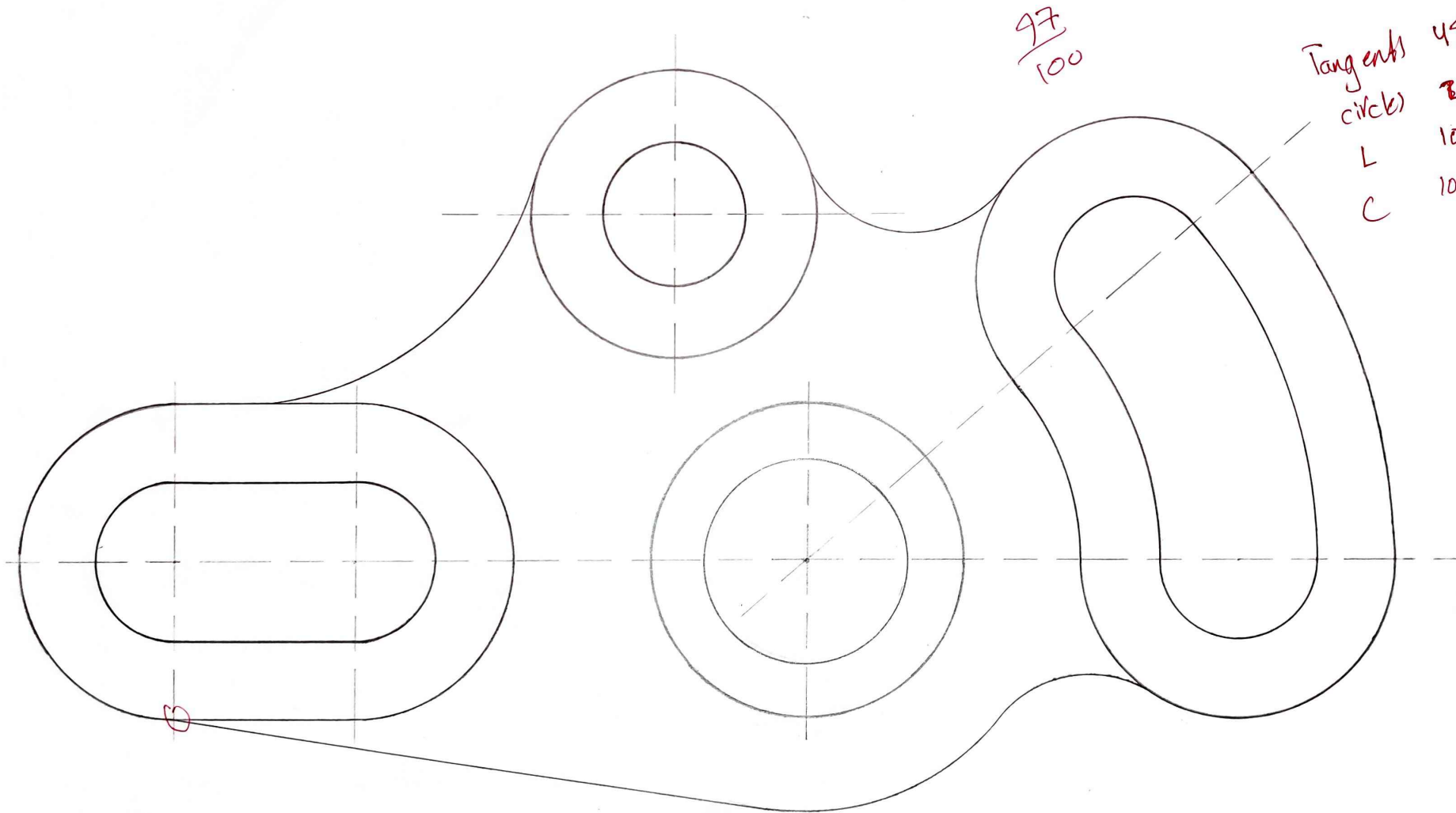

97
100

Tangents
circles
L 49/50
C 28/30
10/70
10/110

TANGENTS	OBAYDA SARRAJ	1211128	R10	7/10/2021	2:1
----------	---------------	---------	-----	-----------	-----

POLYGONS

Class Work

Scale 2:1

Point C: Center of the sheet

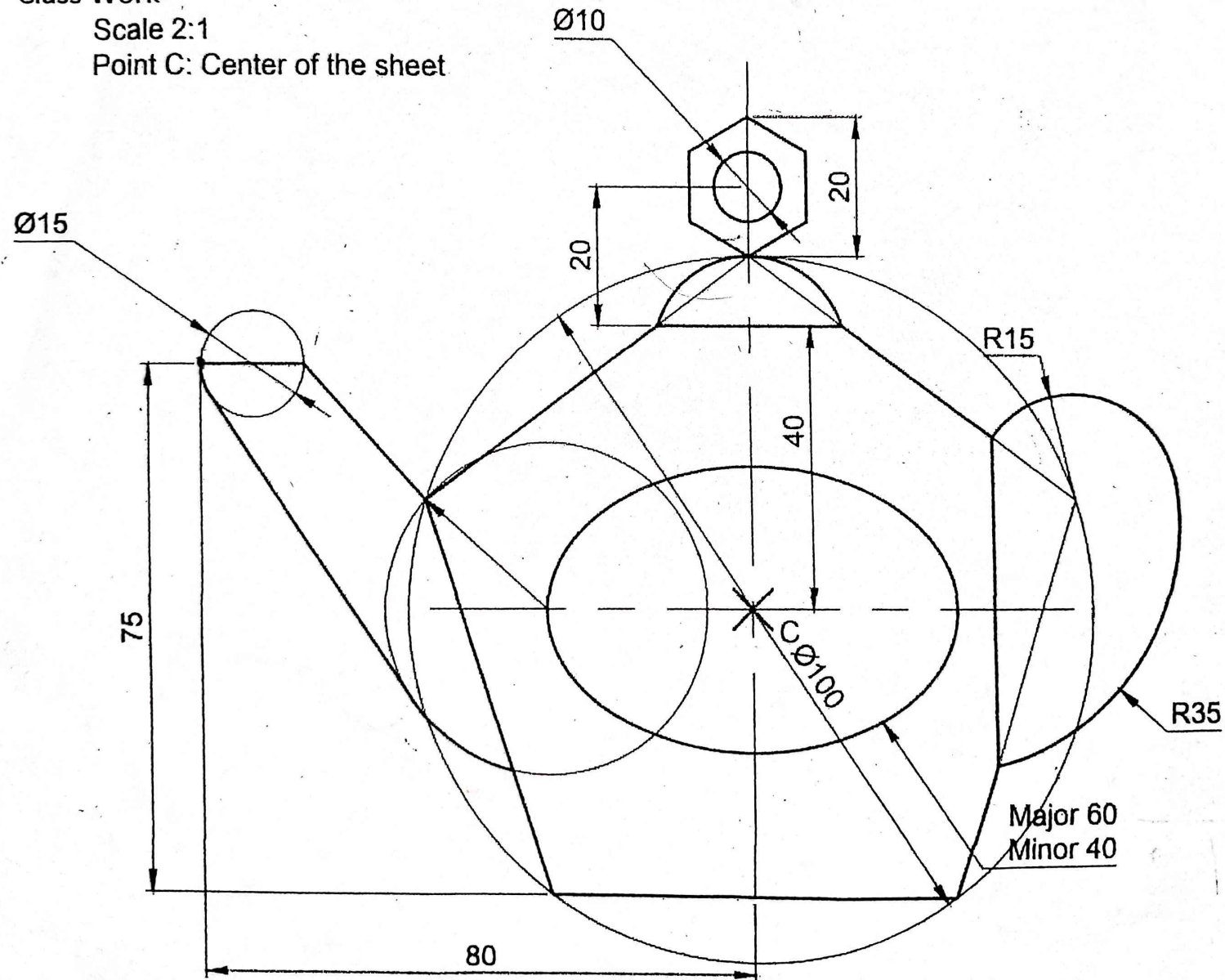

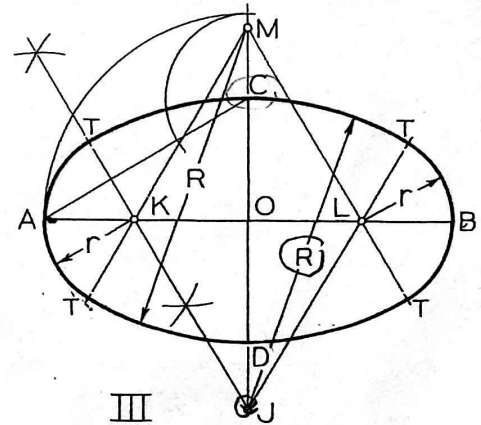
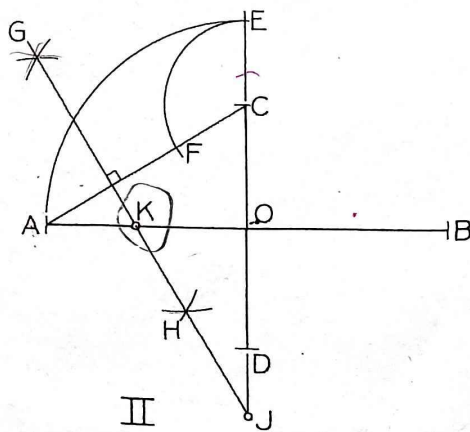
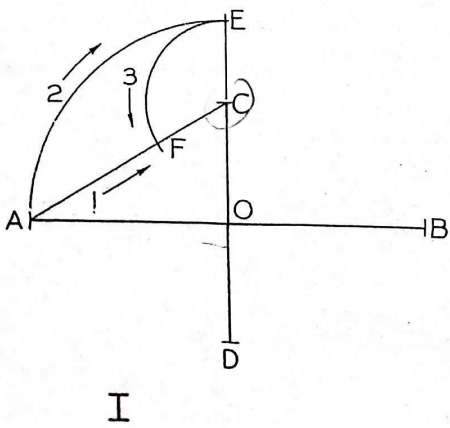
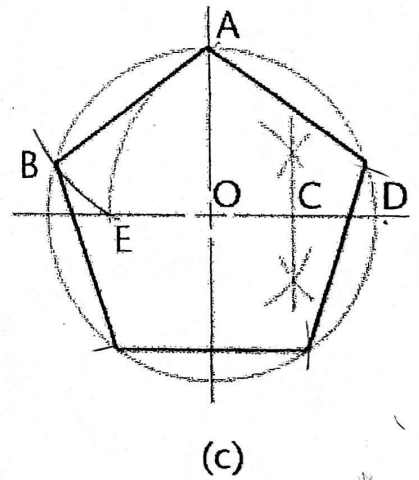
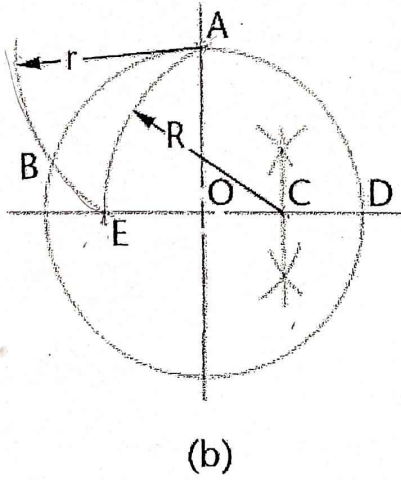
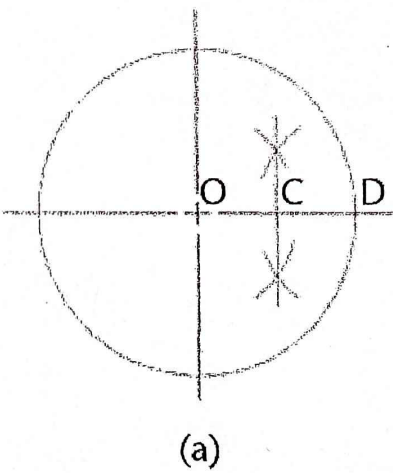
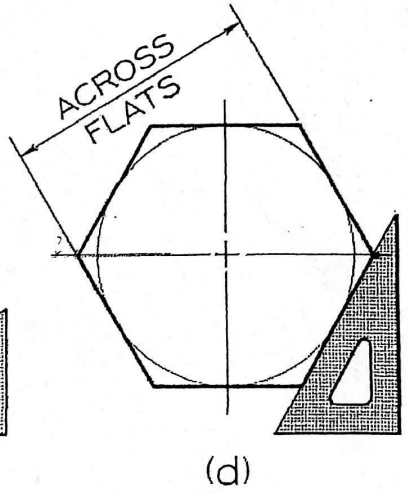
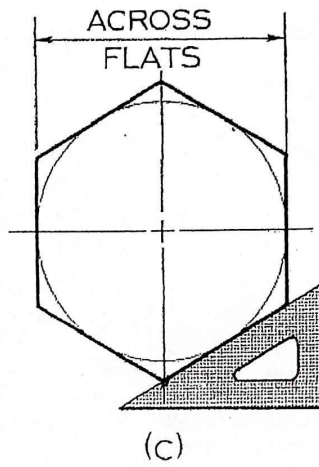
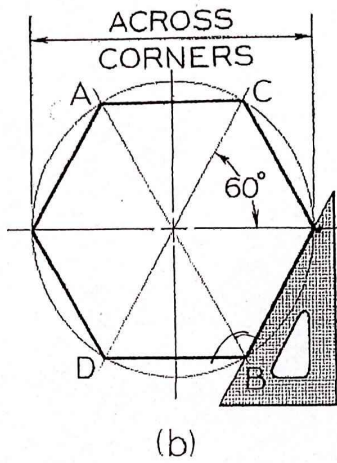
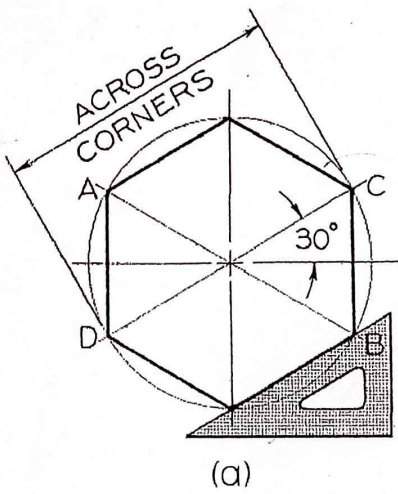
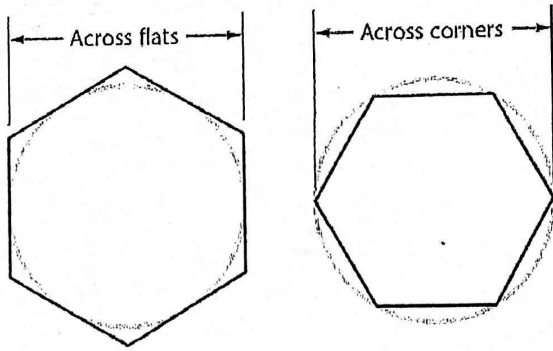

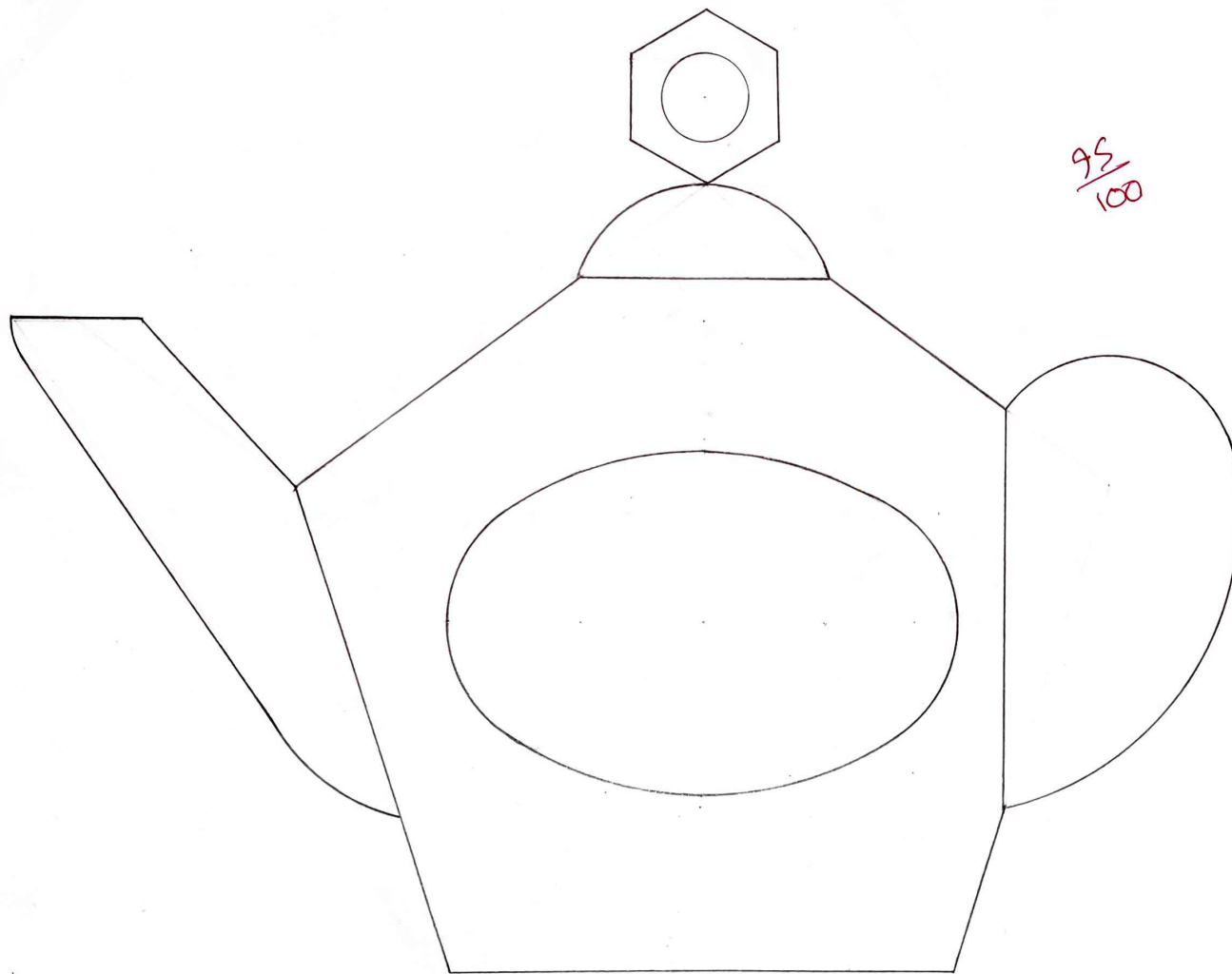

95/100

ellipse 23
pentagon 14
hex 10
3Point 9
head 10
hand 10
C 9
L 10

Home Work

scale 1:1

make the center of ellipse at the center of your sheet

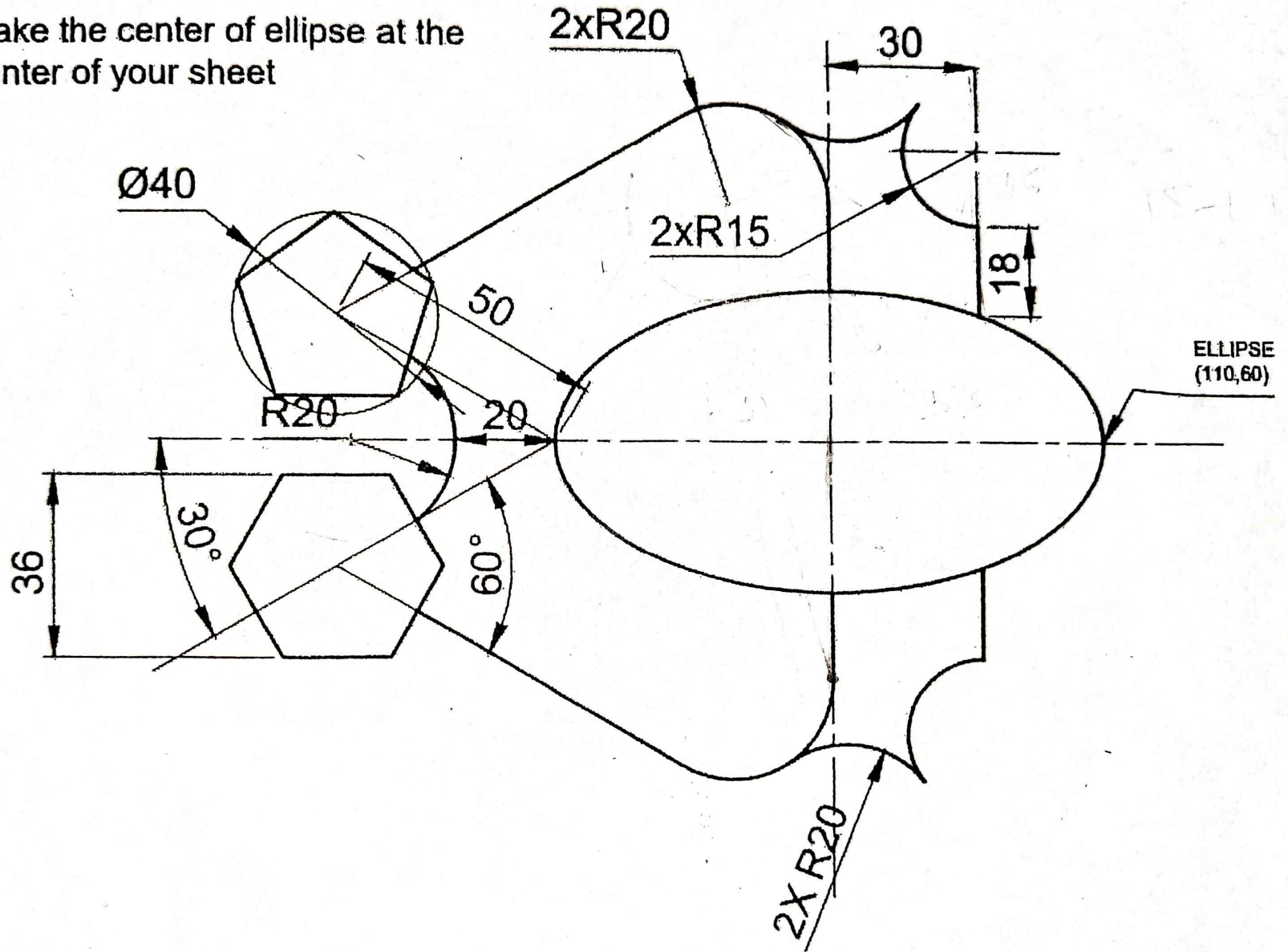

96
/
100

0 77
L 9
C 6

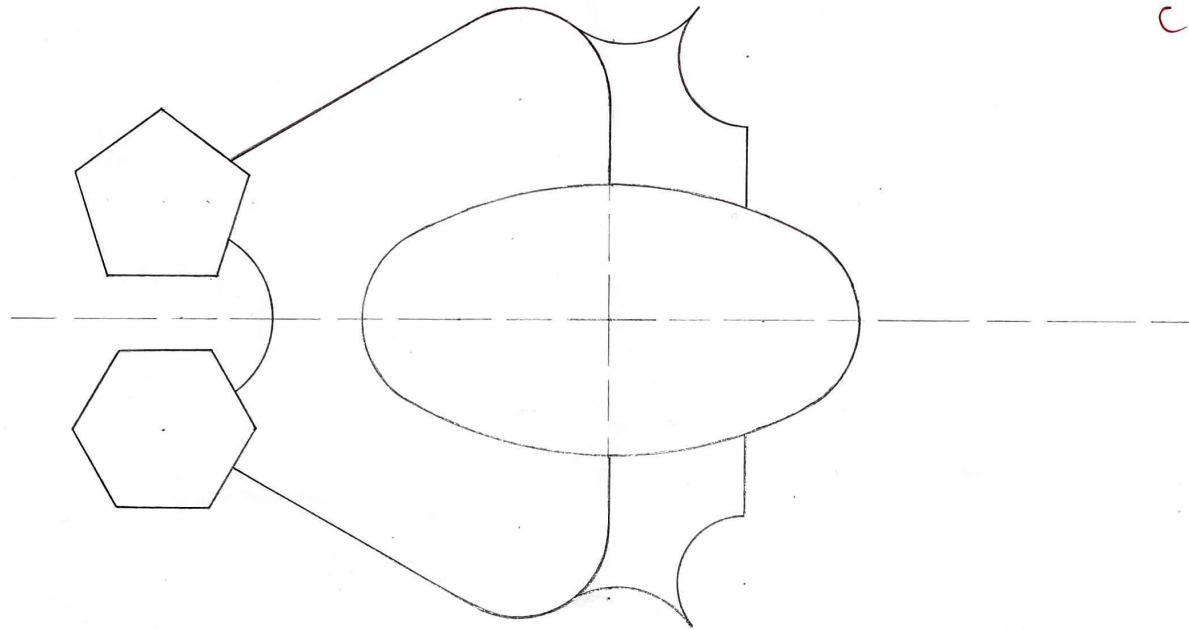

POLYGONS

OBAYDA SARRAJ

1211128

R10

14/10/2021

1:1

Department of Mechanical and Mechatronics
Engineering
Engineering Drawing ENME121
Midterm Exam

Exam duration 2:30Hours:

1st Semester Oct 2021

Problem 1

Using B3 sheet, draw the following figure with drawing instruments taking the scale of drawing as 1:1.

Note:

- All dimensions are all in mm.
- Start at point C (240,170)

$24 + 11 = 35$

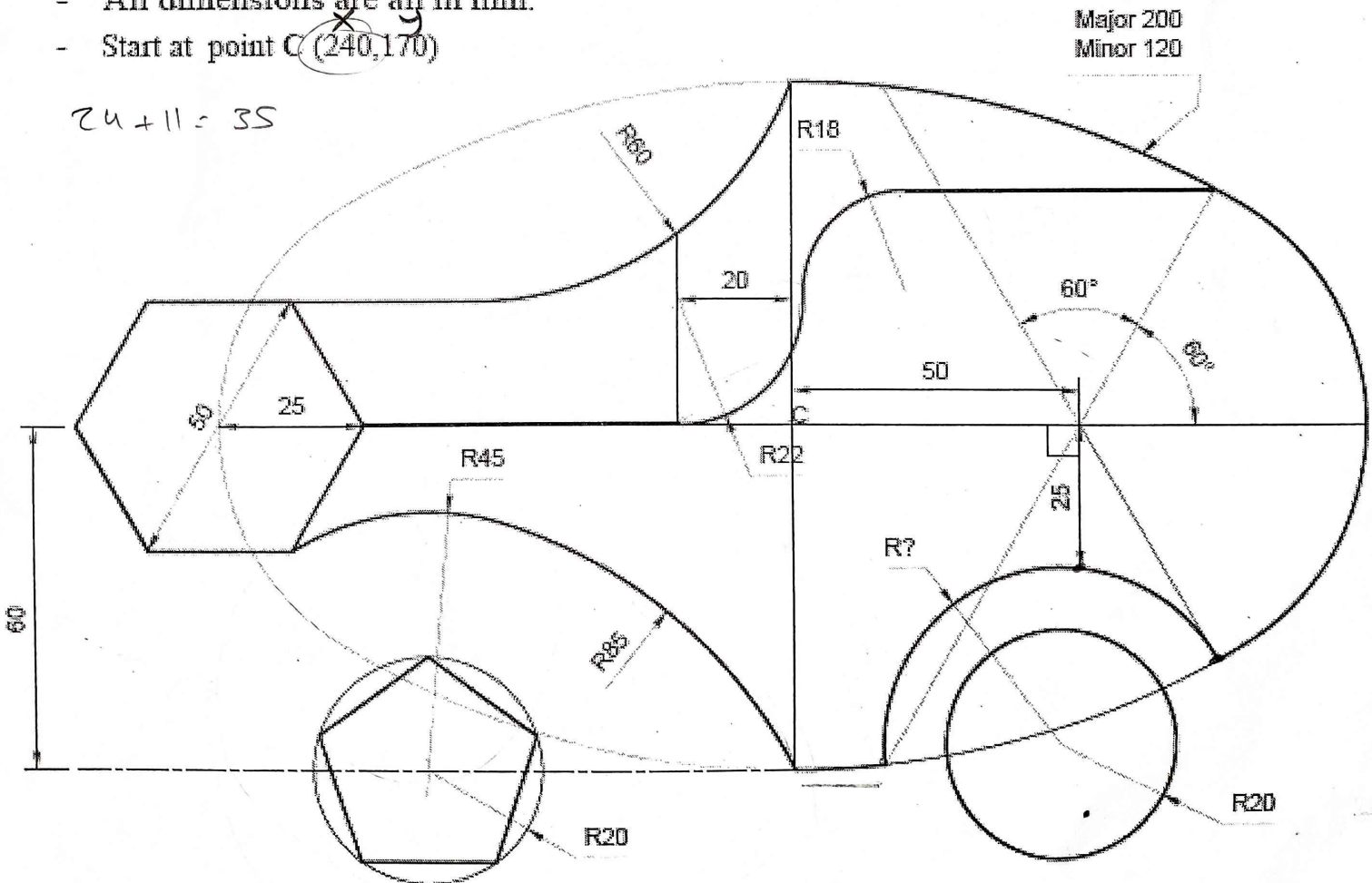

Problem 2:

For the isometric drawing shown in the next page draw all necessary views

ELL	10	10
Hex	7	7
Pent	7	6
Wheel	7	7
UC	5	5
MC	7	7
LC	7	7
L+C	10	10
Total	60	

59/60

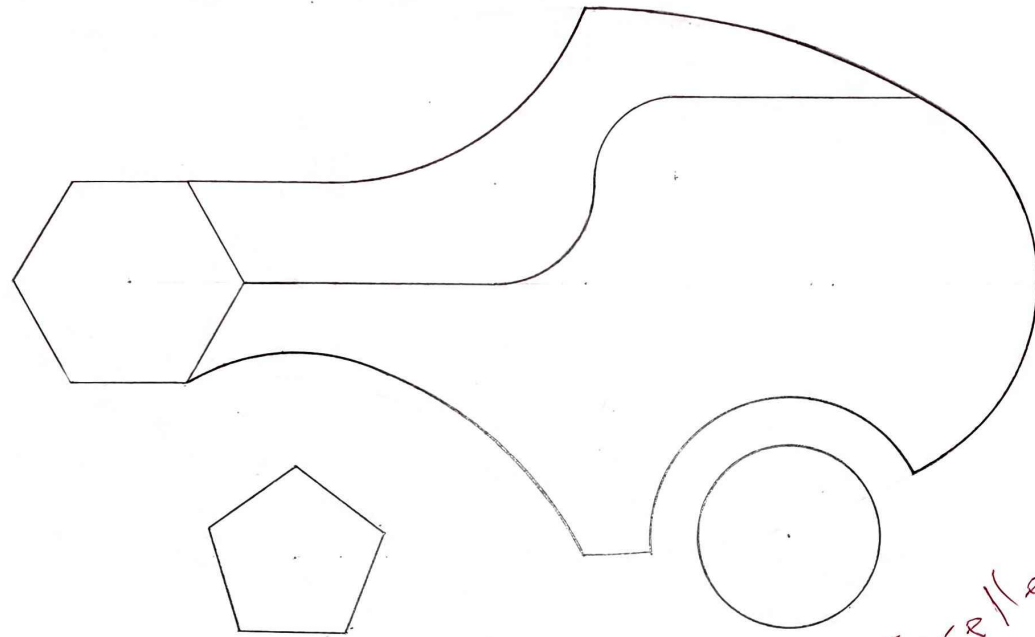

Excellent

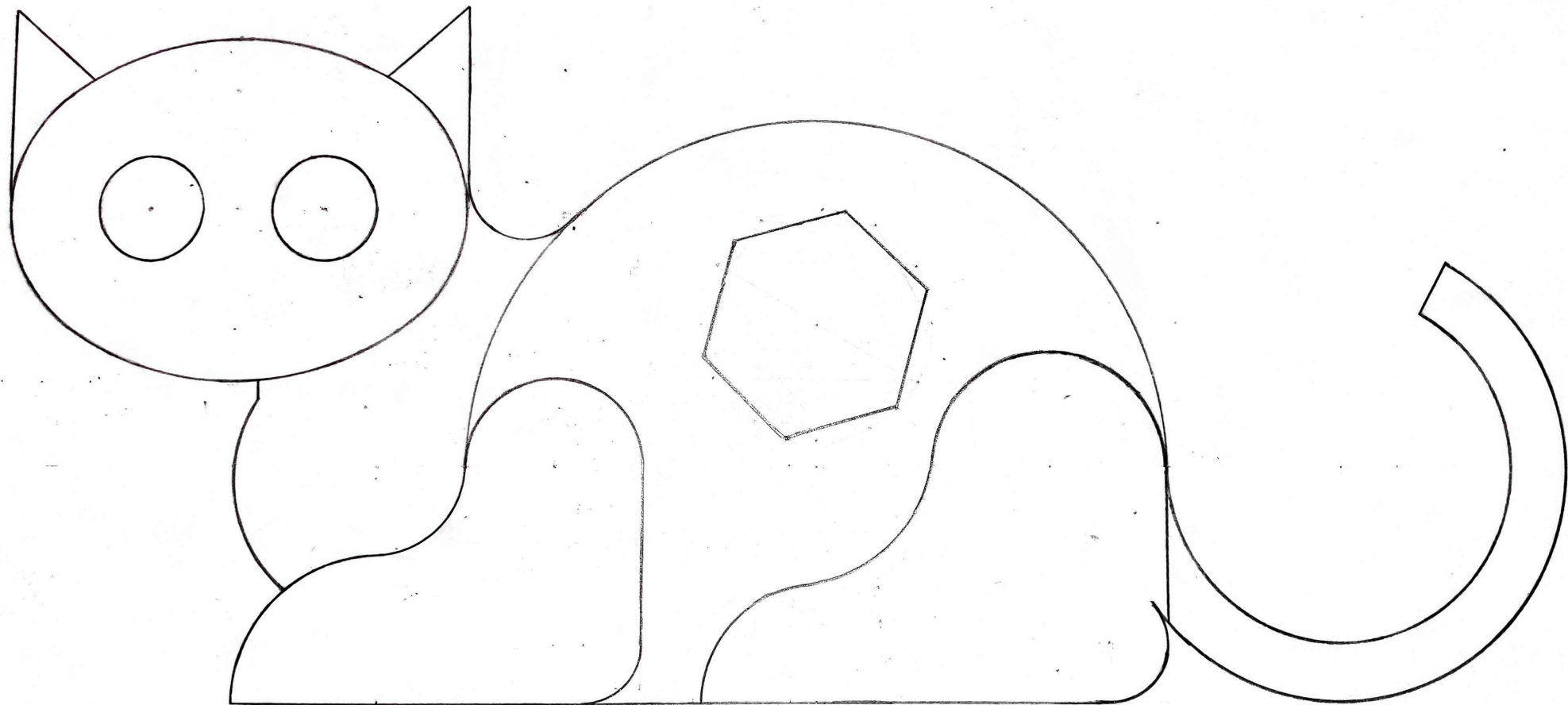

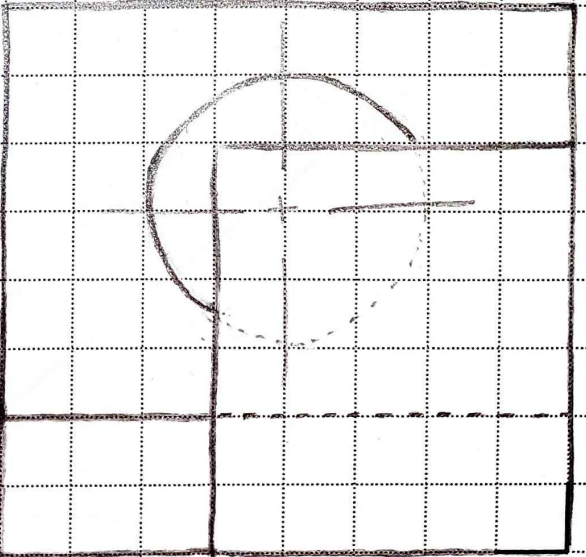
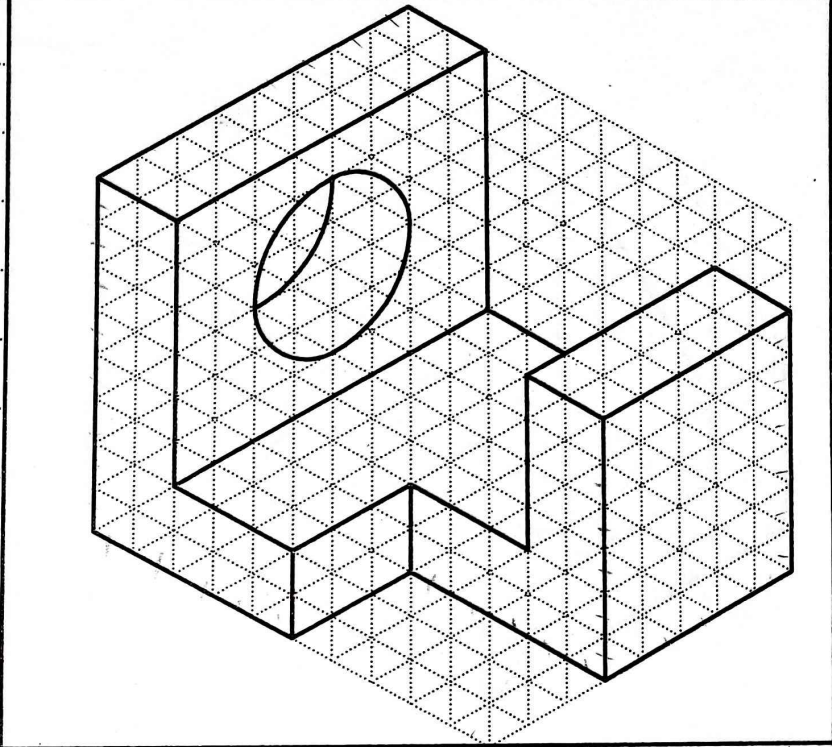
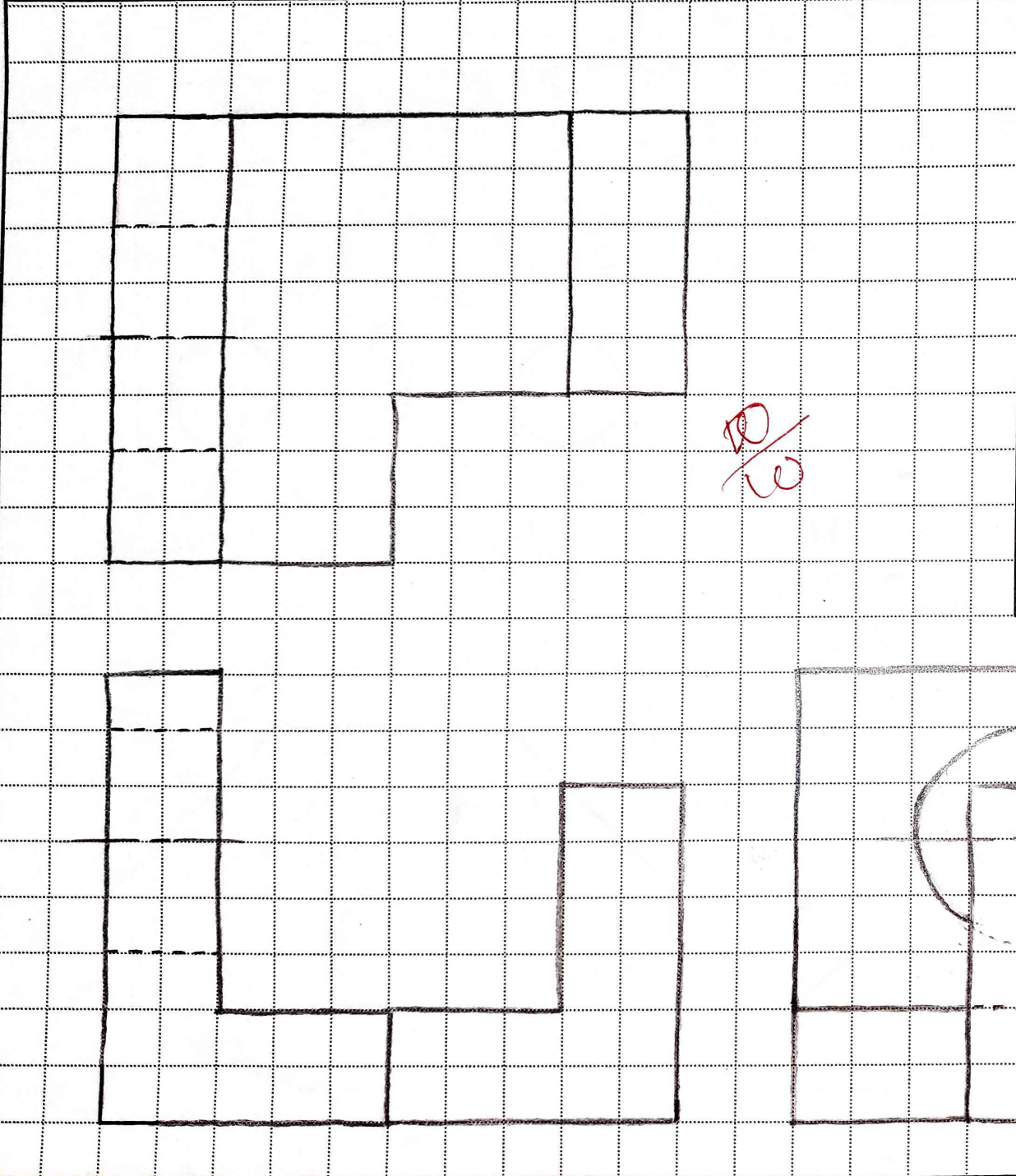

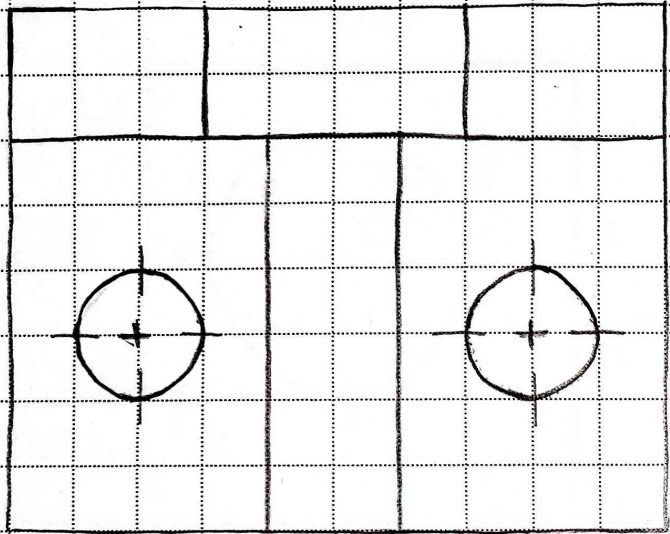

10
/
10

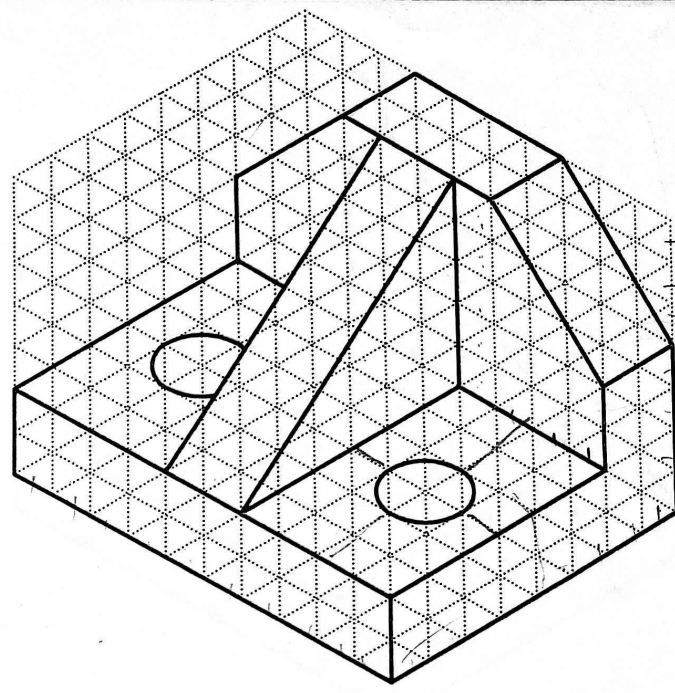
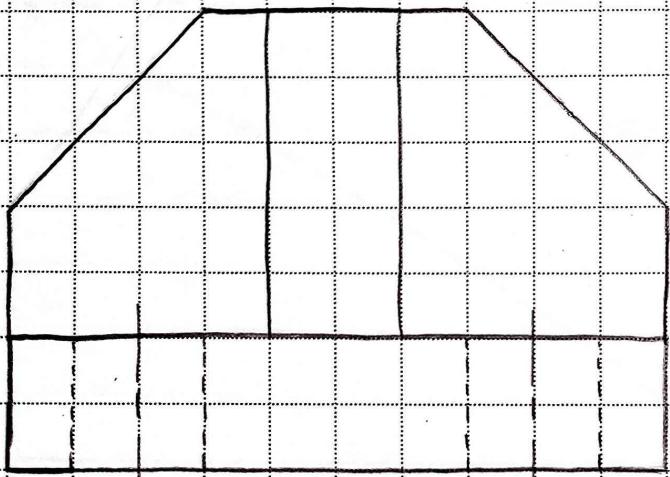

Name:

ID:

Sec:

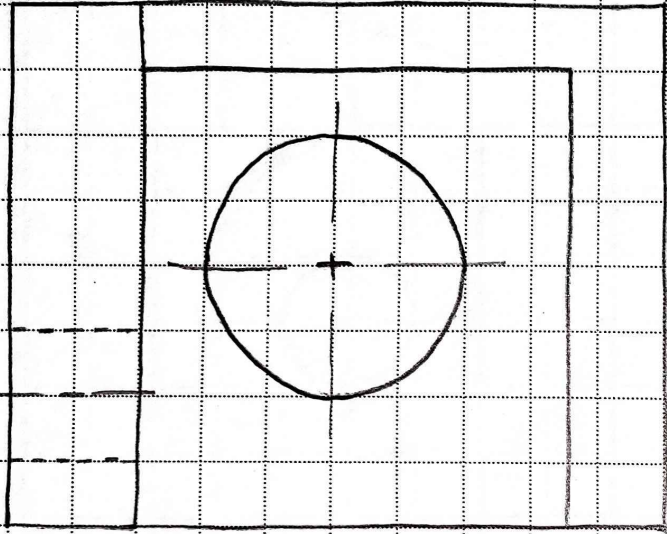

~~W.A.S~~
C.O

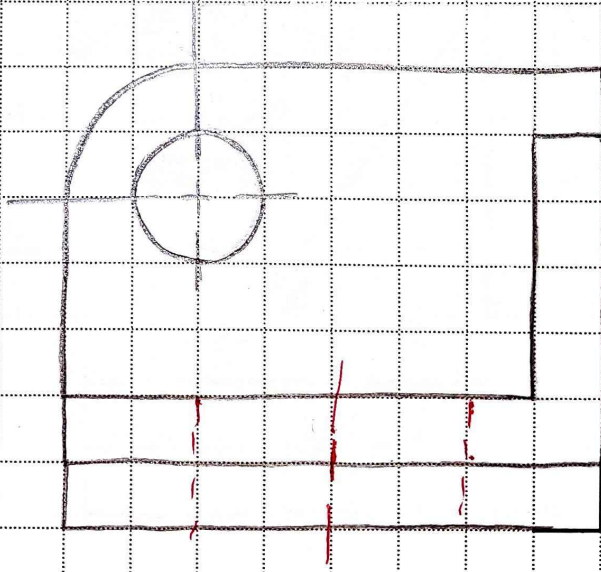
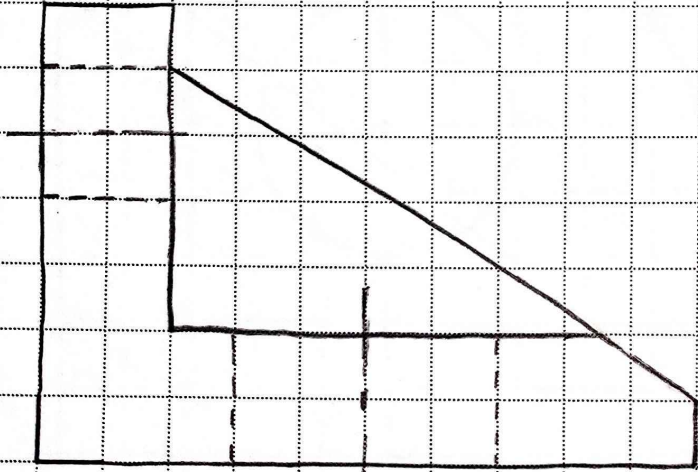
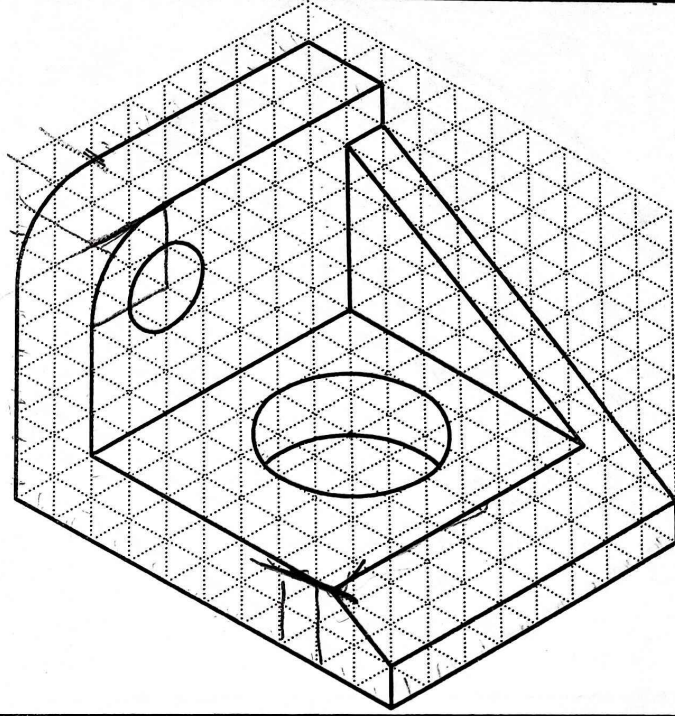

Name:

ID:

Sec:

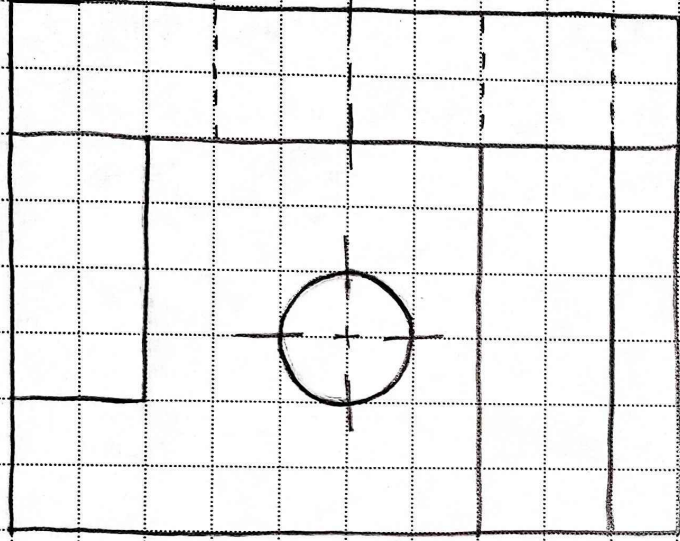

10/20

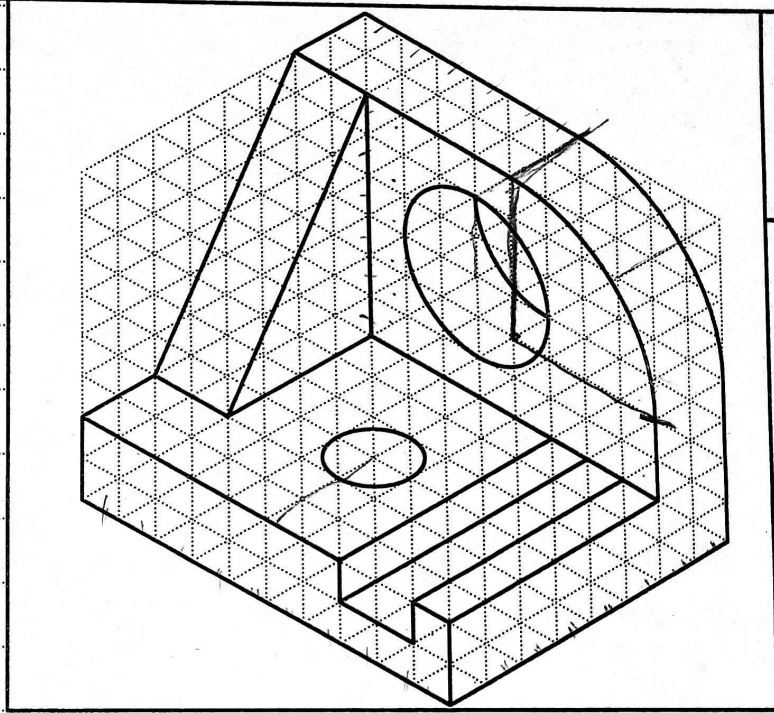
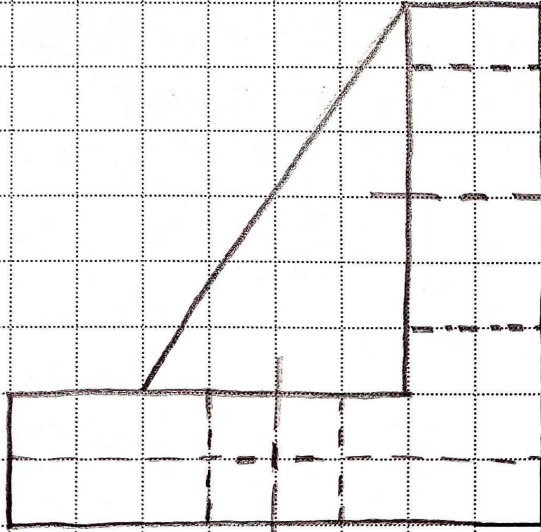
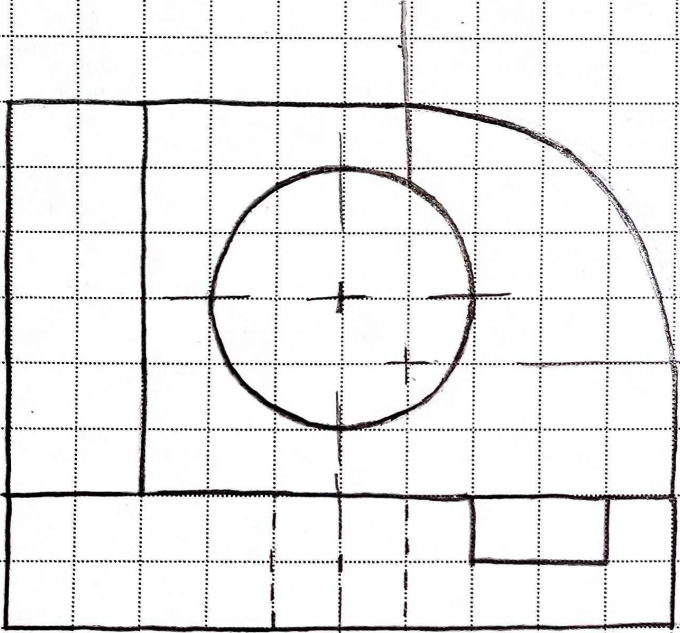

Name:

ID:

Sec:

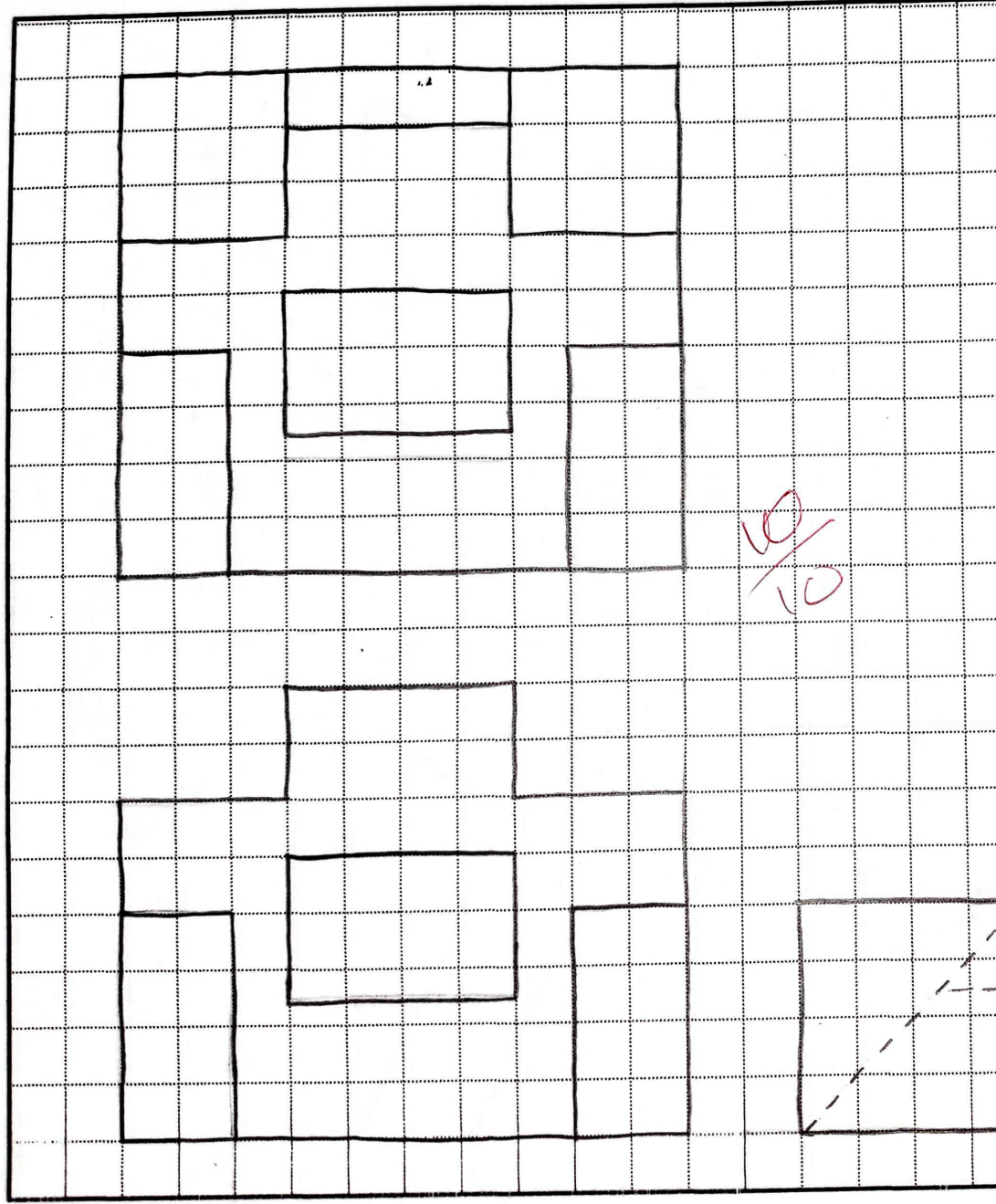

10/10

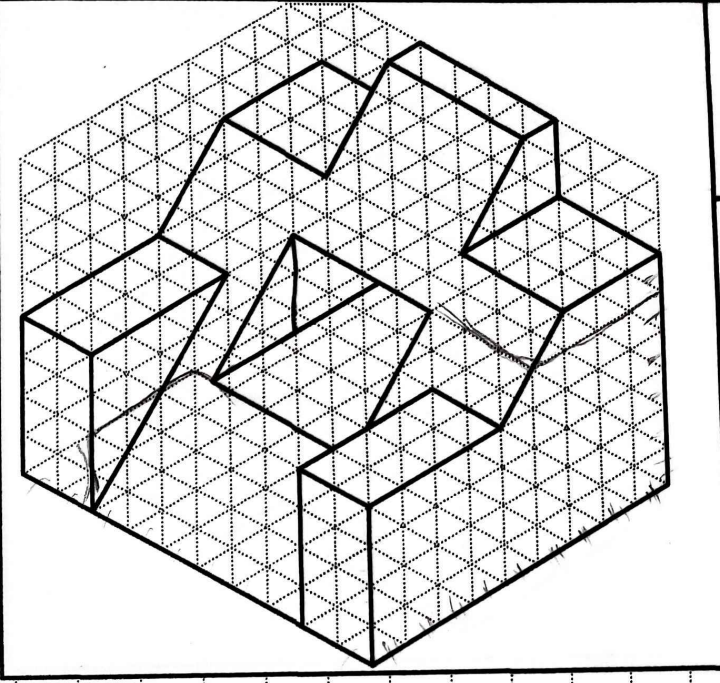

Name: OBAYDA SARRAJ

ID: 1211128

Sec: R10

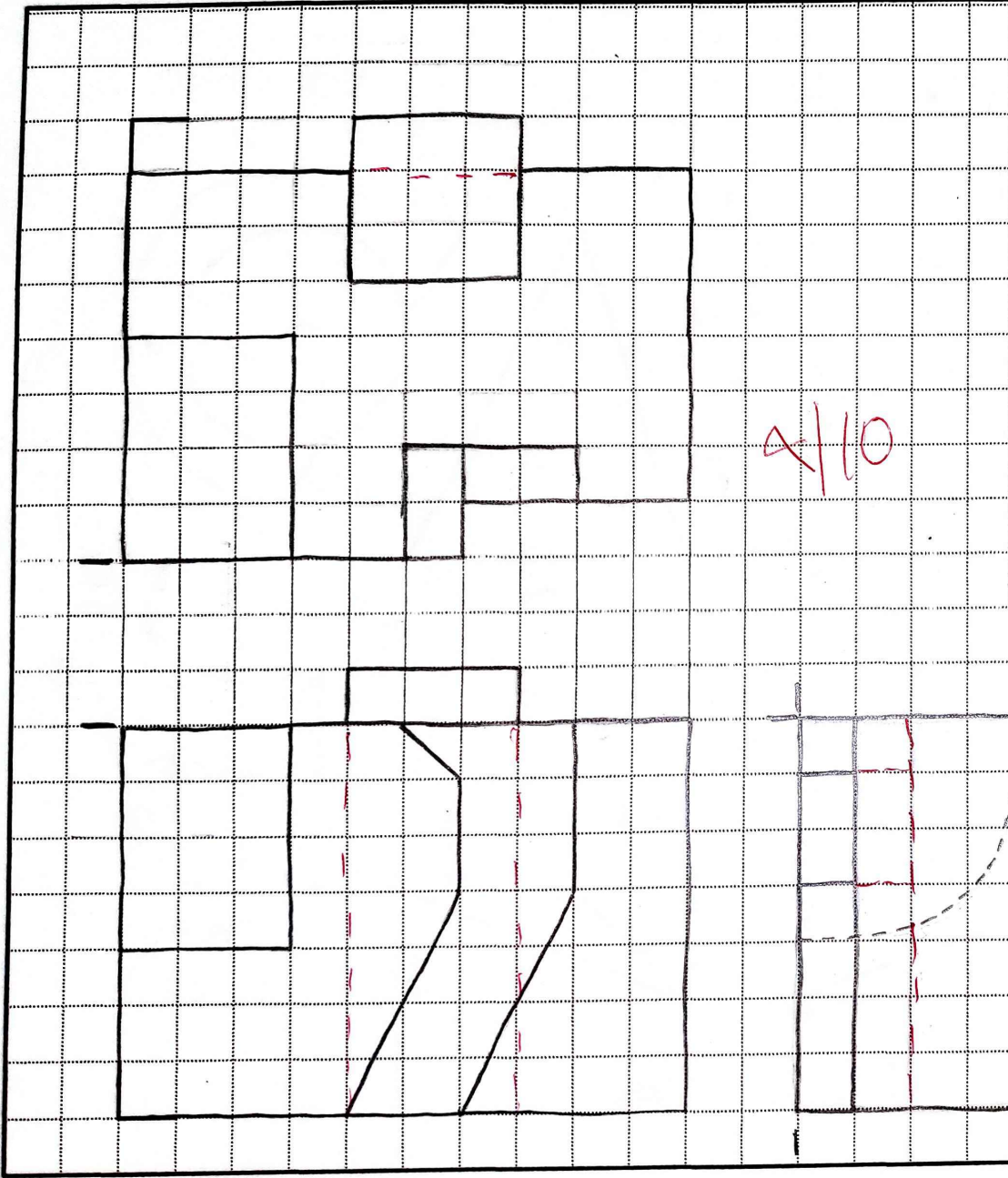

2/10

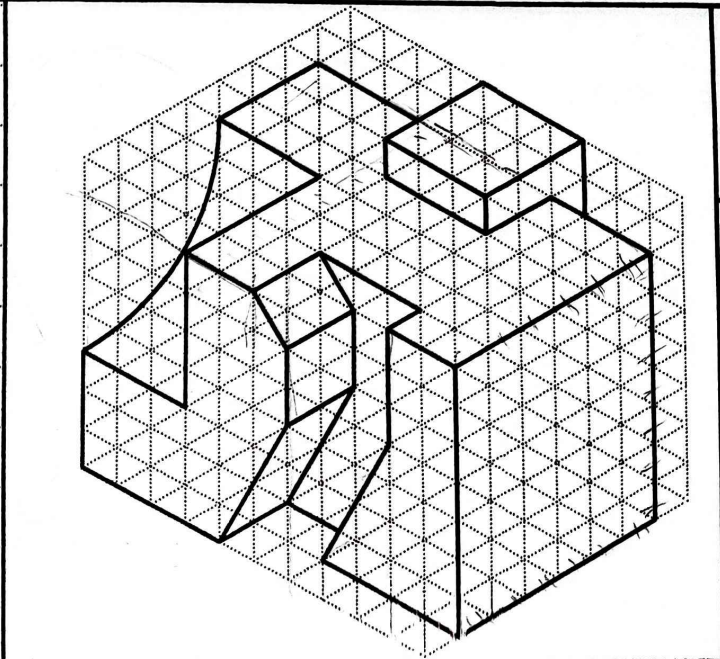

Name: _____ ID: _____ Sec: _____

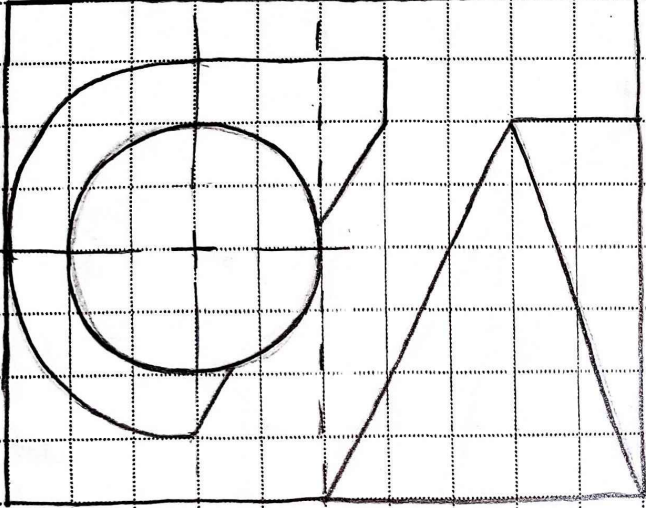

2/10

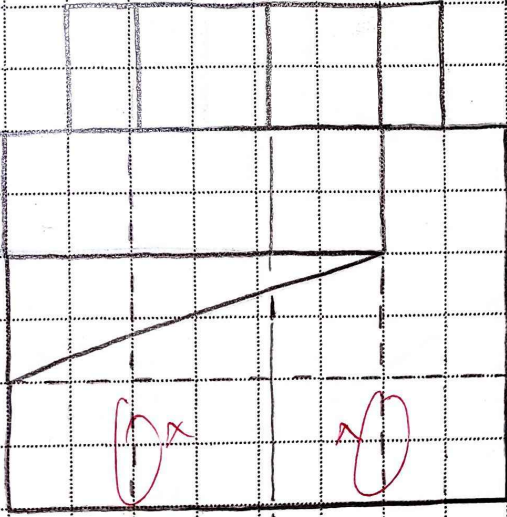
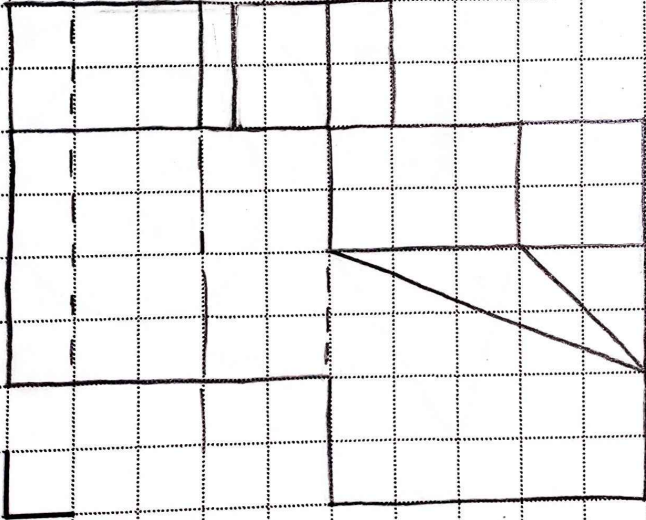
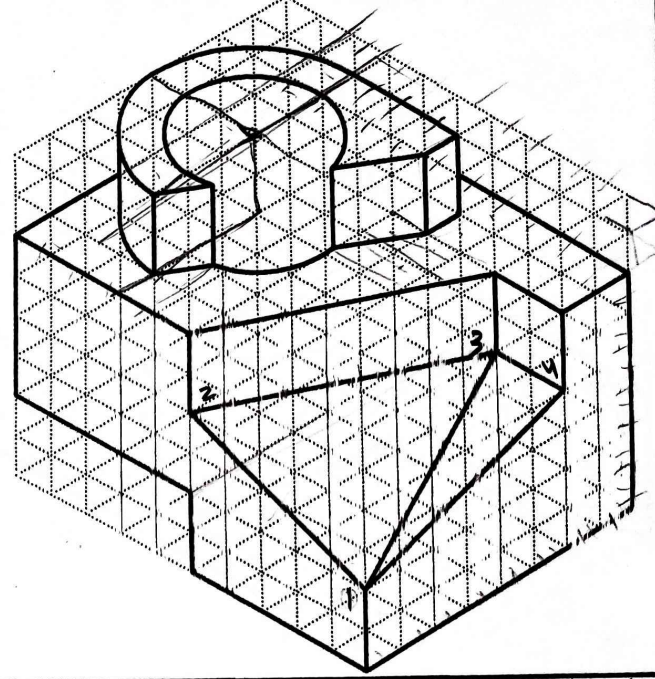

Name: _____ ID: _____ Sec: _____



A/10

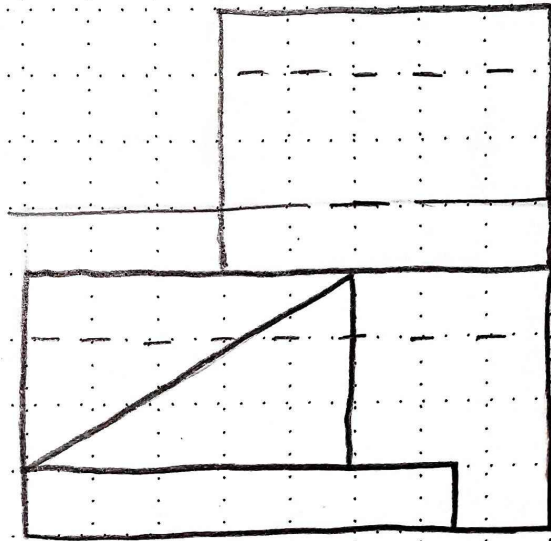
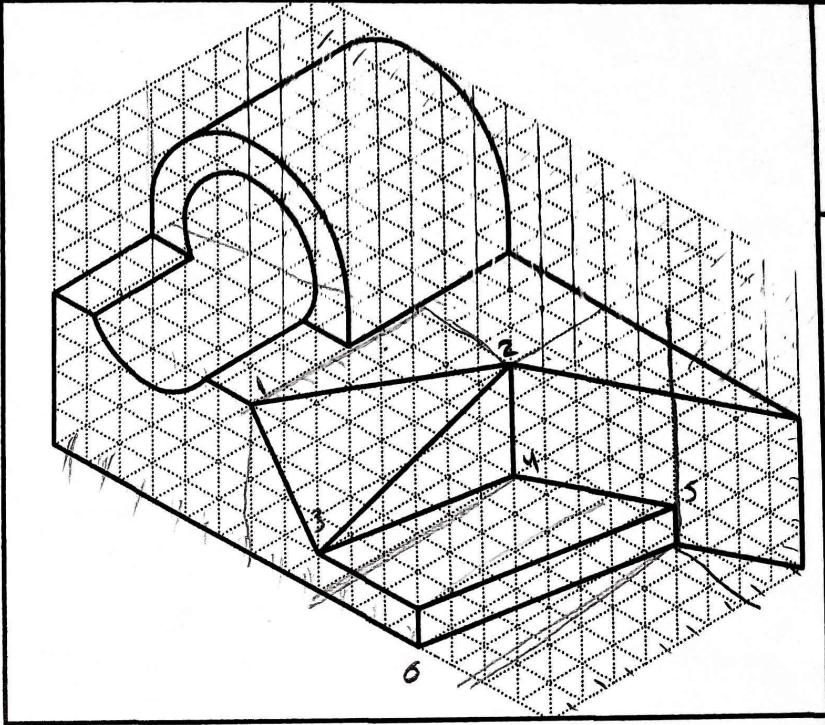
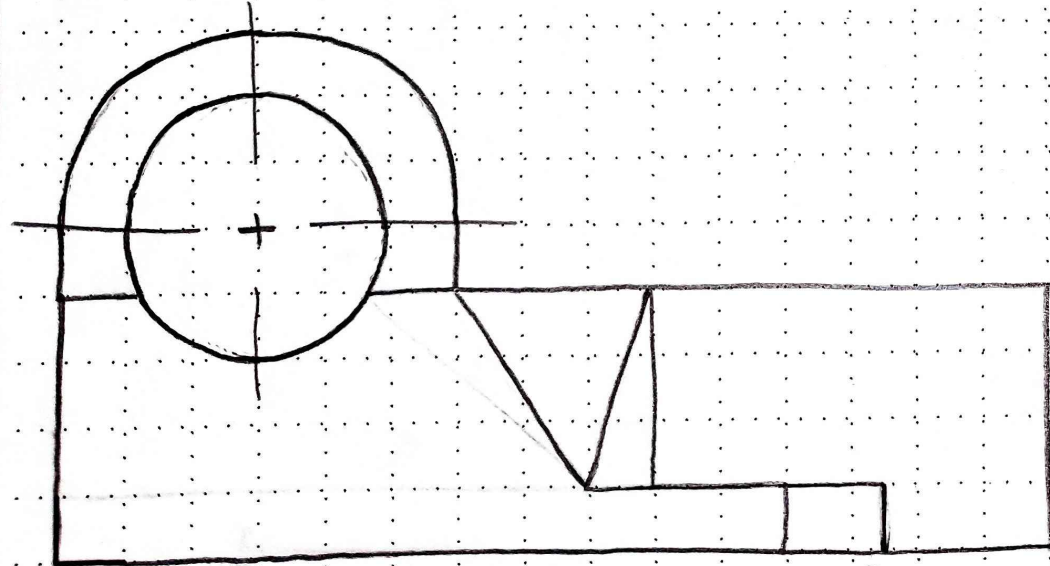

Sec:

ID:

Name:

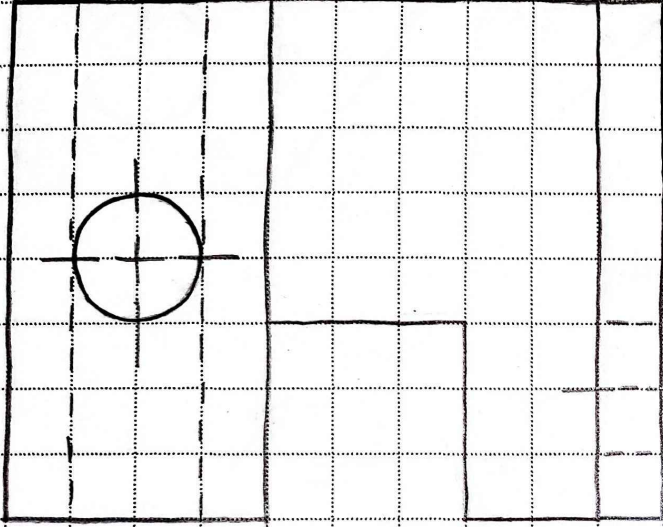

A.S/10

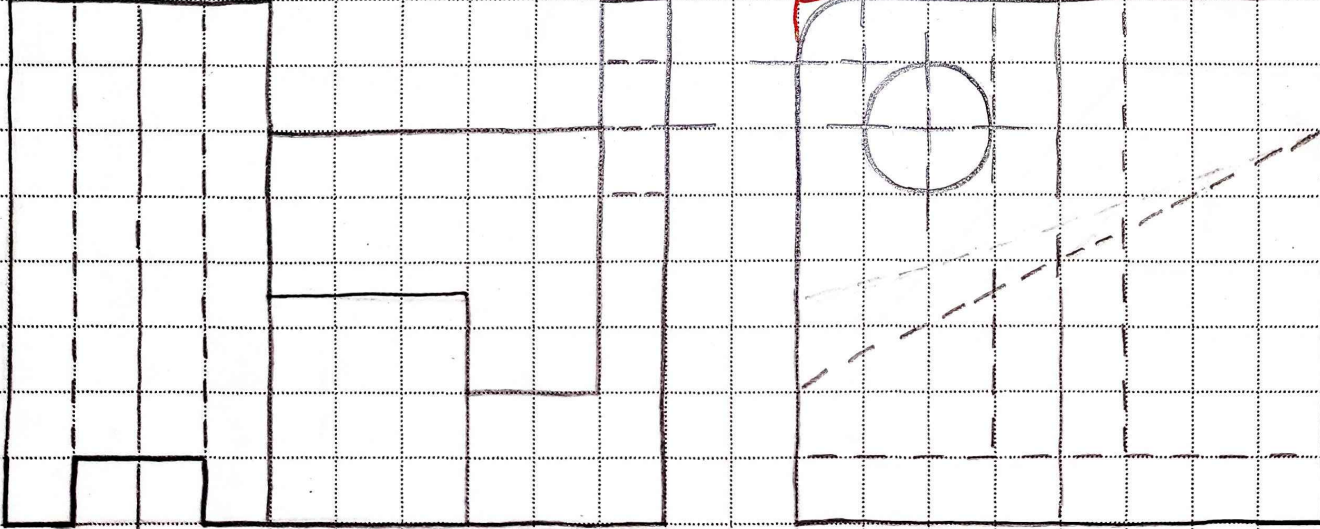
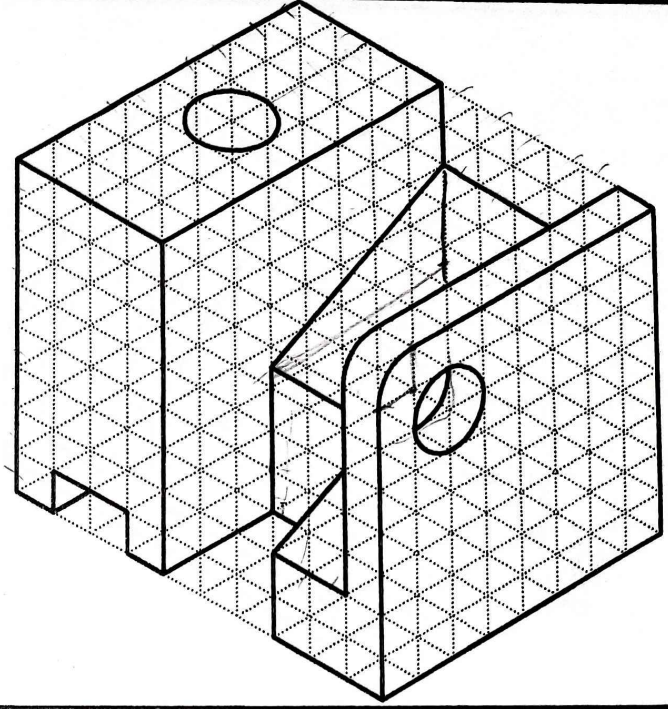

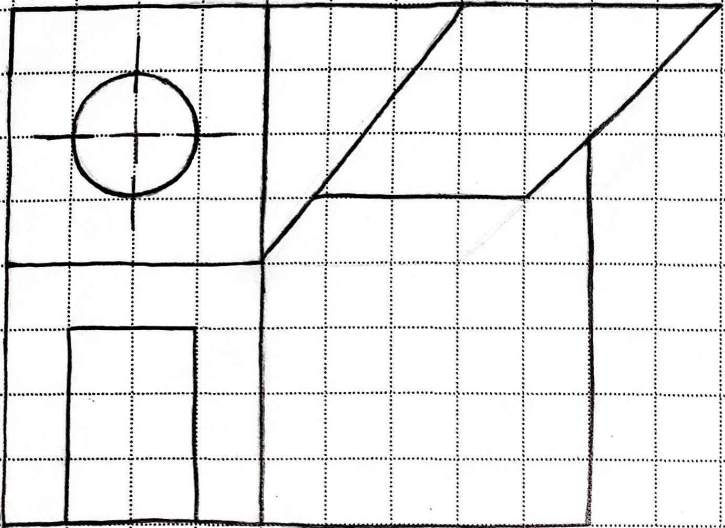

W/H

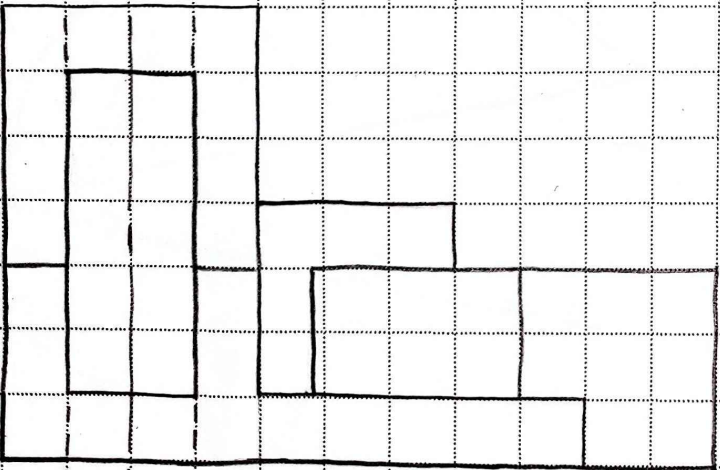
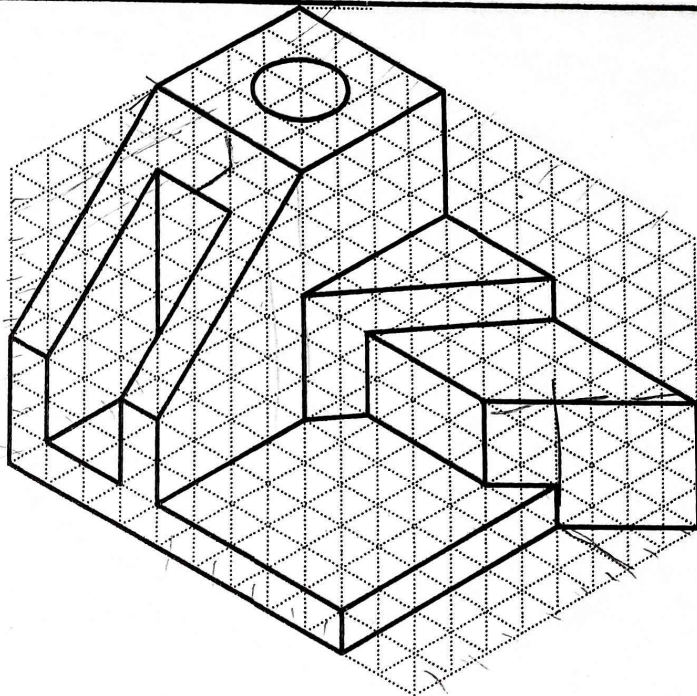

Name:

ID:

Sec:

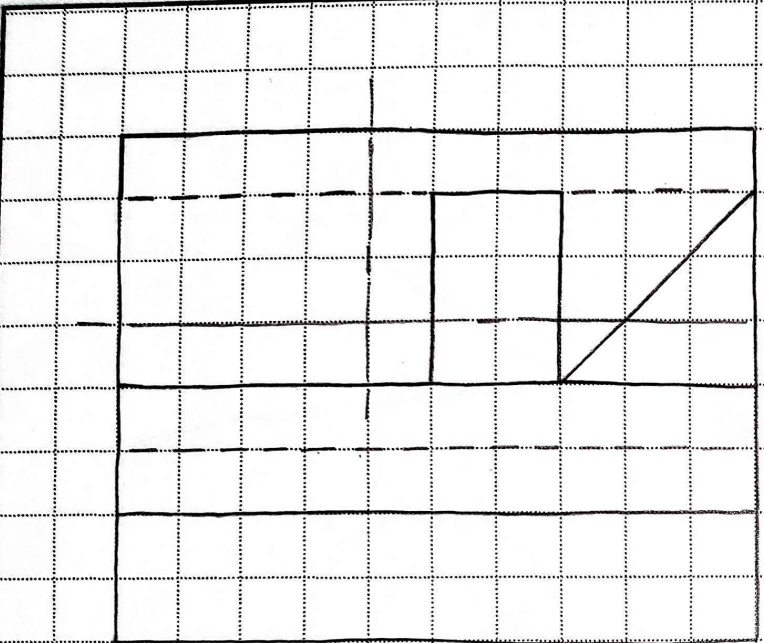

10/10

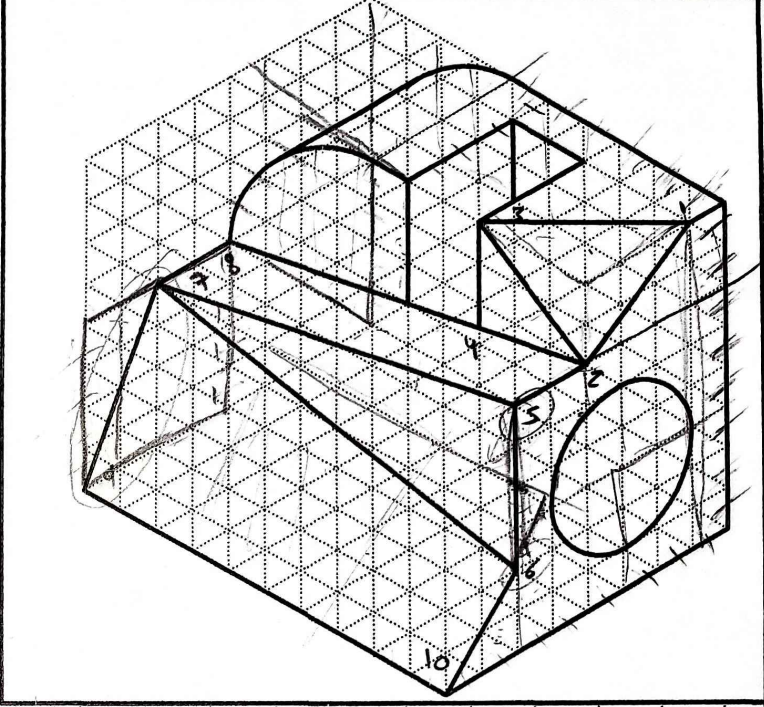
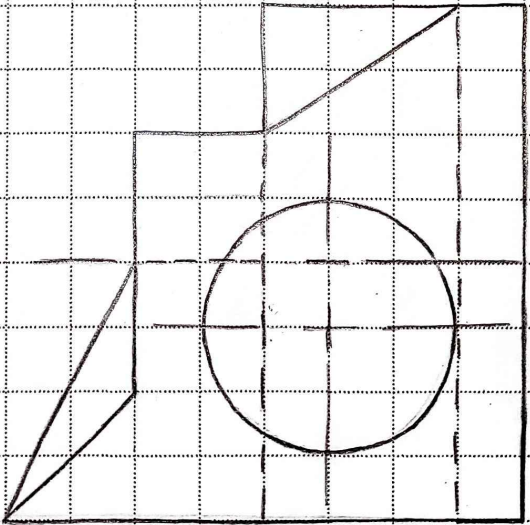
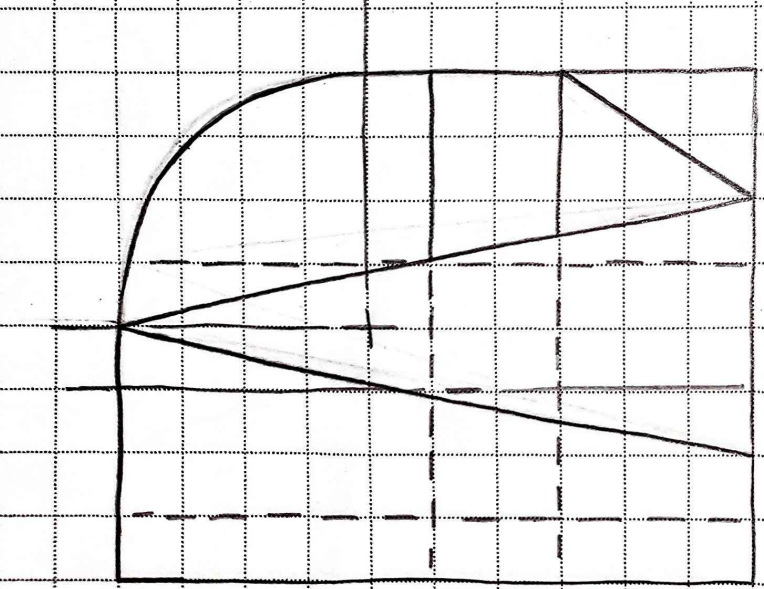

Name: _____ ID: _____ Sec: _____

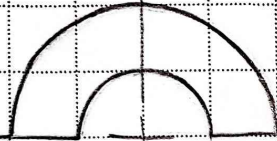
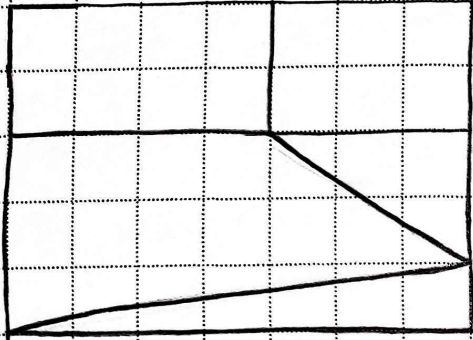

10/10

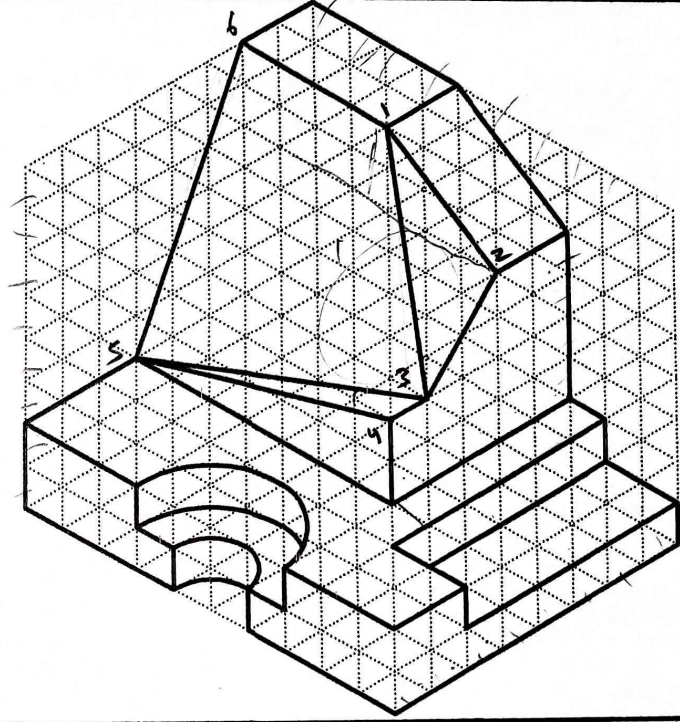
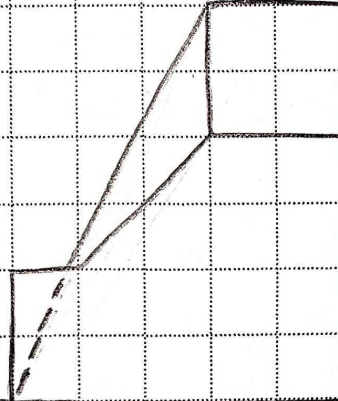
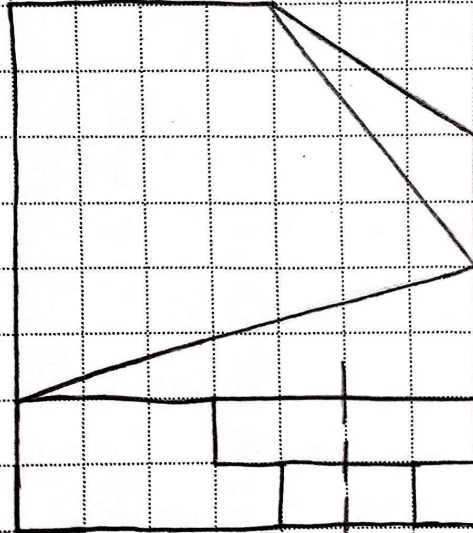

Name:

ID:

Sec:

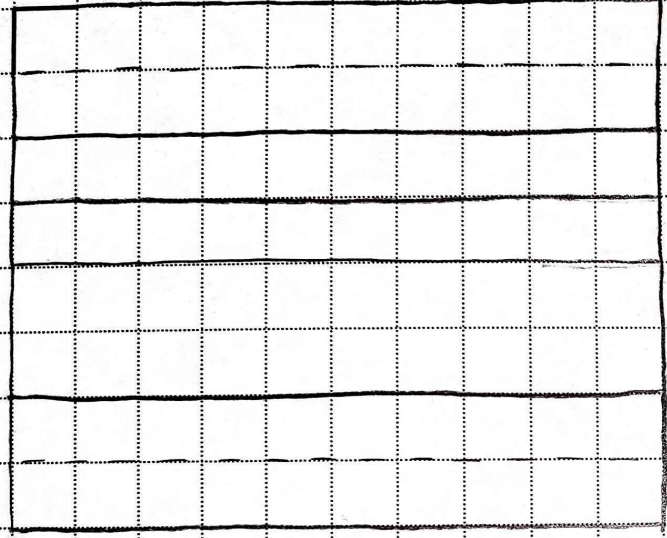

10/10

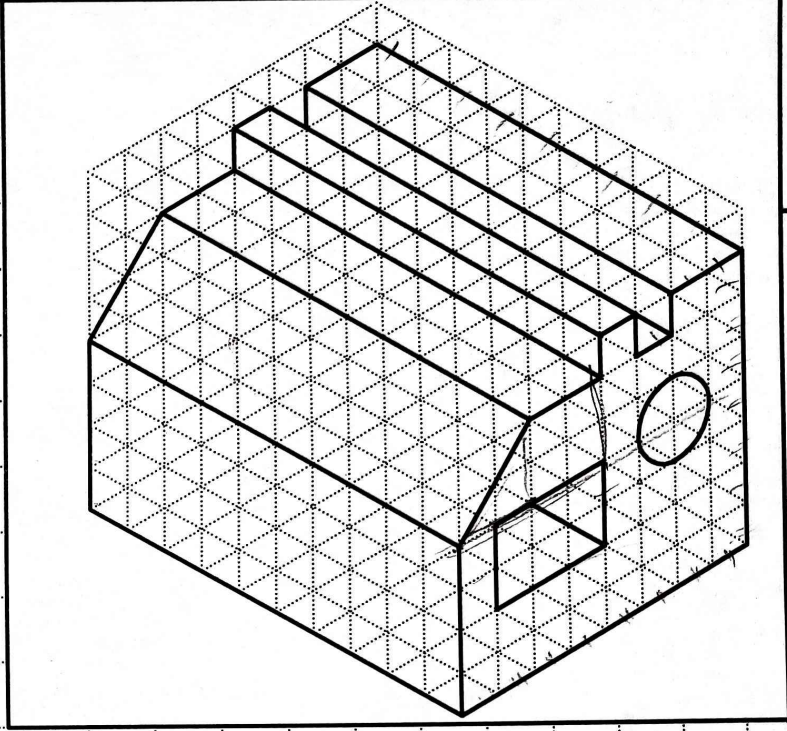
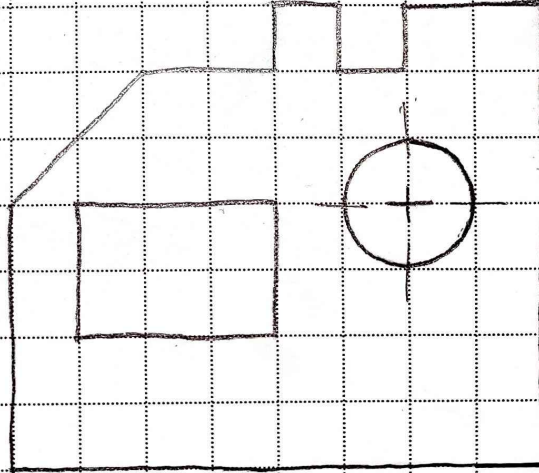
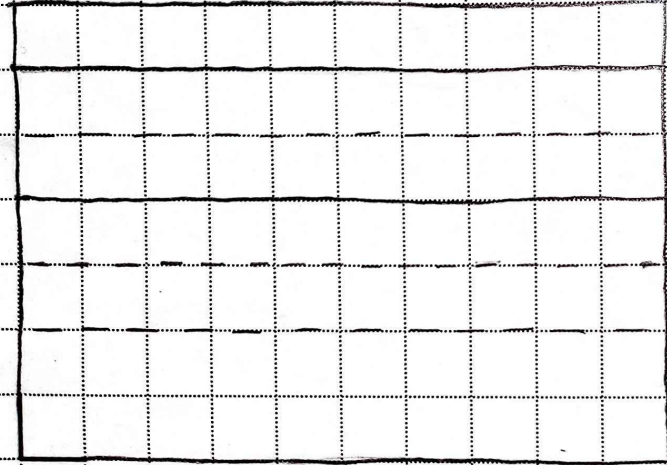

Name: Omayda Sarroj

ID: 1211128

Sec: R10

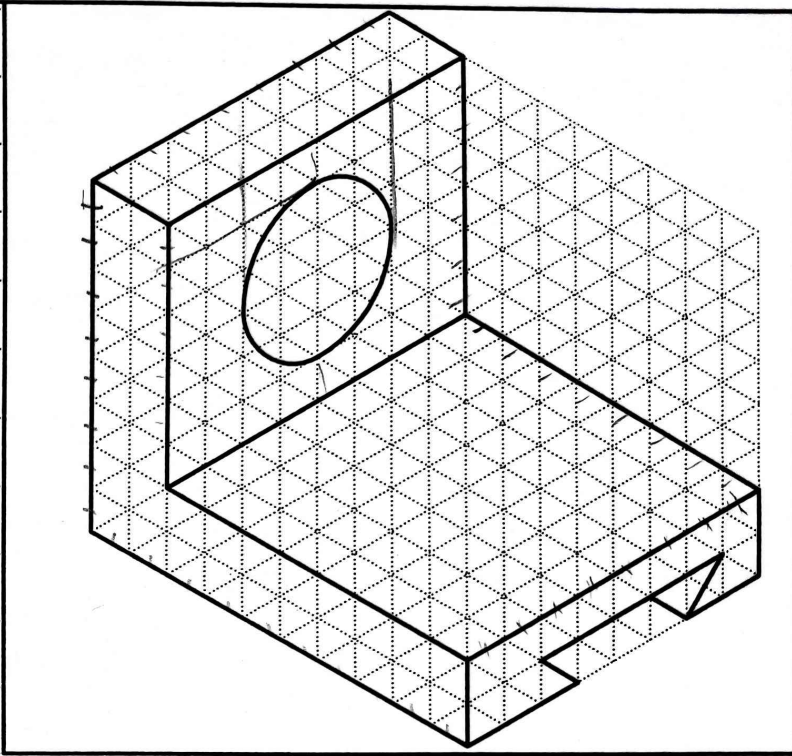
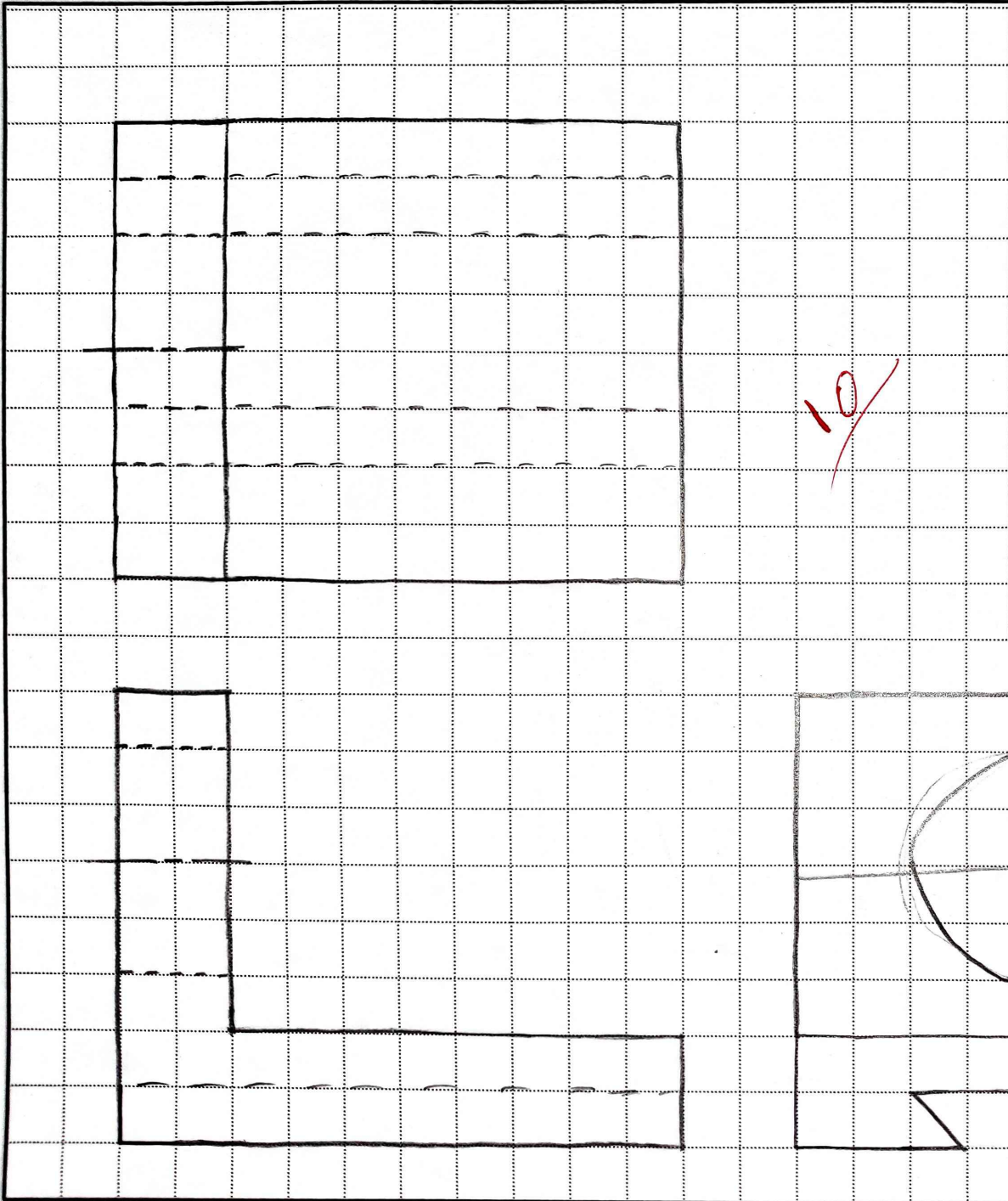

Name: Gbayda Sarrej

ID: 1211128

Sec: R10

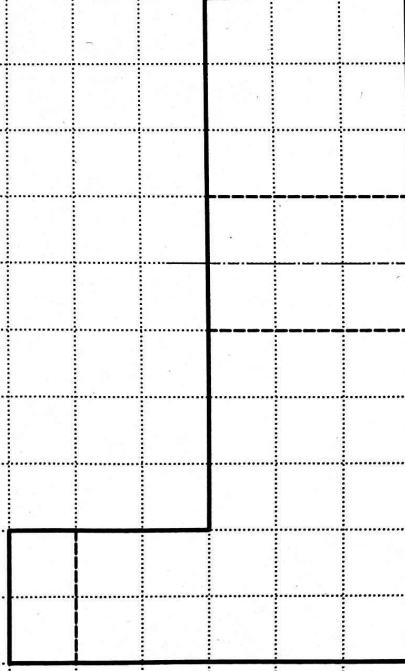
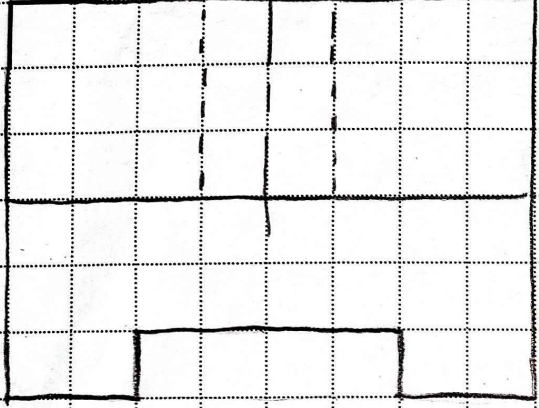
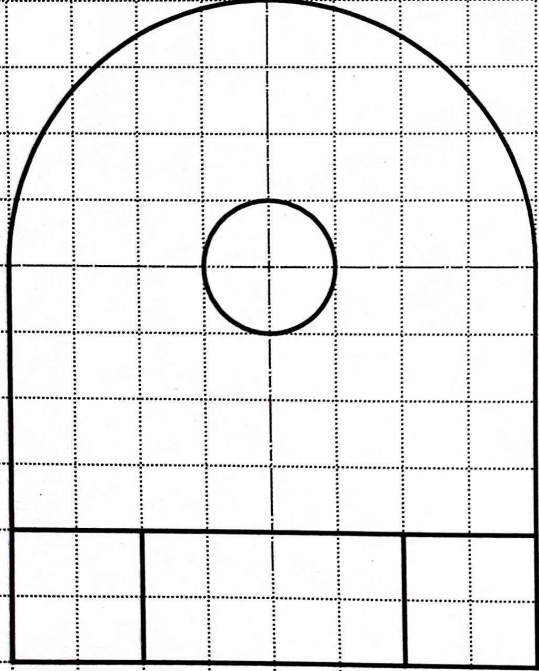

5/4

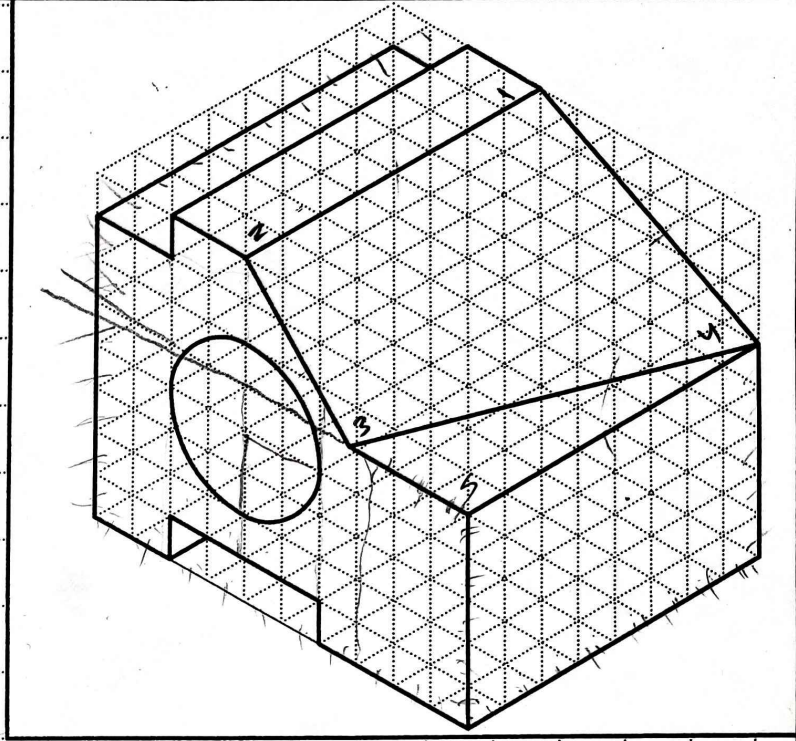
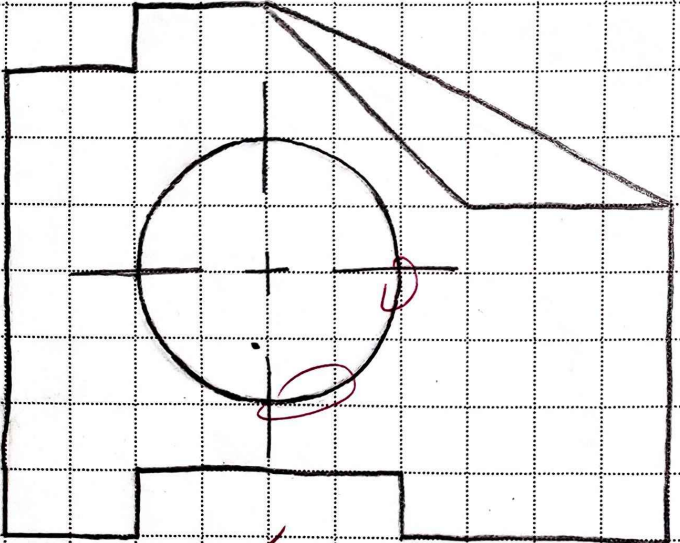
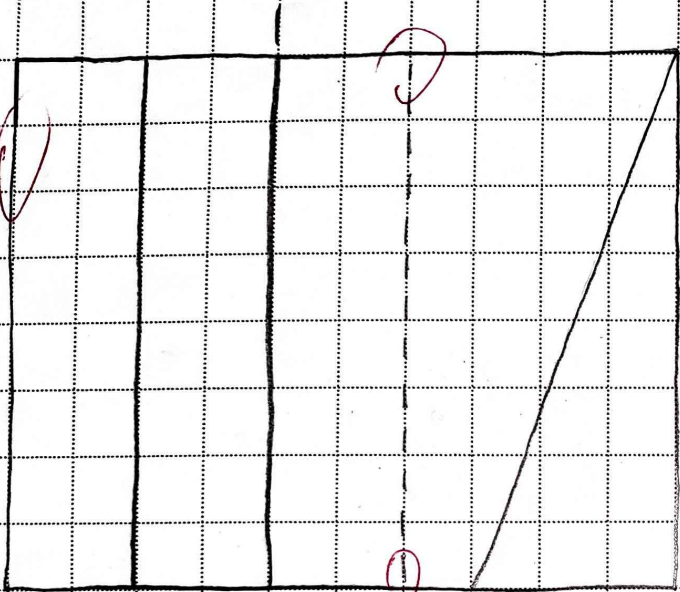

FV 11.5
 TV 11.5
 RV 11
 left. 3

37

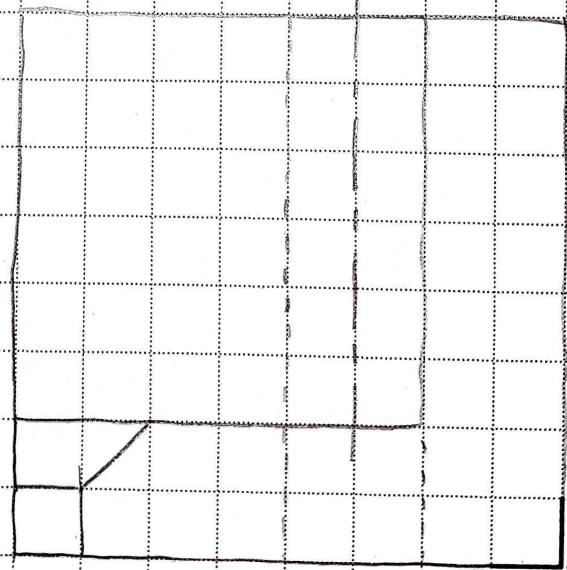
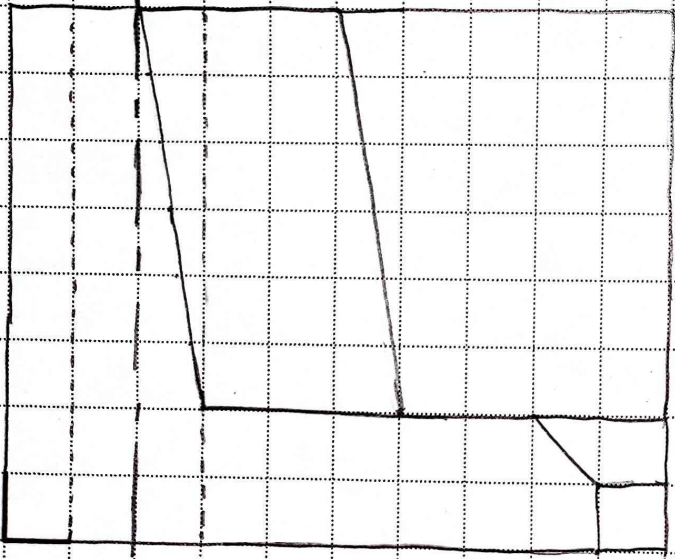
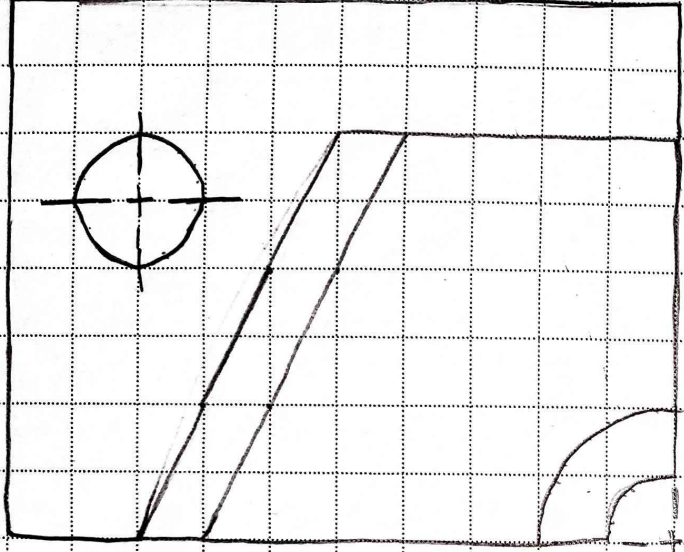

2.5/2.5

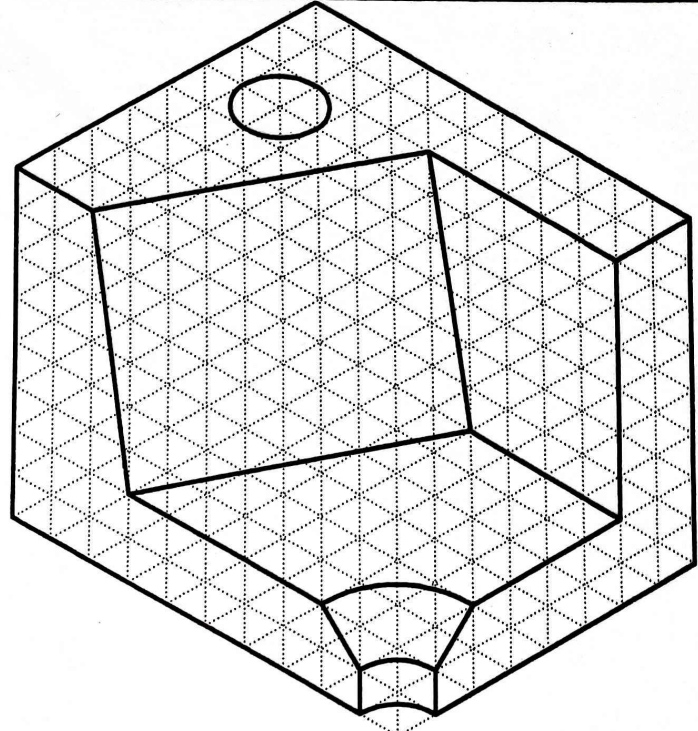

Figure (2)

