

Birzeit University – Faculty of Engineering
 Mechanical Engineering Department
 Fluid Mechanics ME 335
 First Exam

Instructor: Dr. Afif Hasan

2nd semester 2011/2012

Note: Specific weight of water $9790 \text{ N/m}^3 = 62.4 \text{ lb}_f/\text{ft}^3$

Problem 1 (15%)

The hydraulic jack in figure 1 is filled with oil ($s.g. = 0.90$). Neglecting pistons weight, what force F required on handle to support 2000 lb_f weight shown.

Problem 2 (55%)

Water depth behind a dam is 6 m ; at the base of the dam there is 2 m by 3 m exit tunnel as shown in figure 2. At end of a tunnel a quarter circle gate is hinged at the center (pivot point) of the cylinder O .

- a. Calculate the horizontal force and its location on the gate [15]
- b. Calculate the vertical component on the gate [15]
- c. Determine the magnitude, direction and location of the resultant force on the gate (an angle and appoint that forces passes through). [10]
- d. What is the moment of resultant force about the pivot point. [5]
- e. What is the magnitude of the vertical force F to prevent gate from rotating, neglecting weight of gate? [10]

Problem 3 (30%)

A solid cylinder is 3 ft in diameter, 6 ft high and weighs 1550 lb_f . The cylinder is placed in oil ($s.g. = 0.90$) with its vertical axis as shown in figure 3.

- a. What is the submerged depth of cylinder? [10]
- b. Would the cylinder be stable? Explain why? [20]

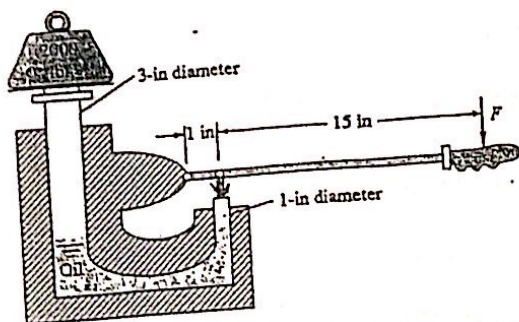

Figure 1

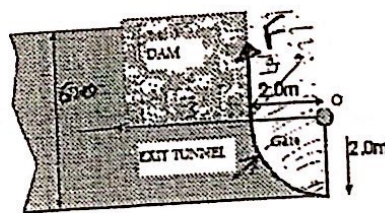

Figure 2

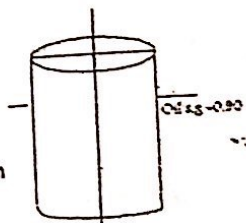

Figure 3