

- 2-1. Water at 120 C and a pressure of 250 kPa passes through a pressure-reducing valve and then flows to a separating tank at standard atmospheric pressure of 101.3 kPa, as shown in Fig. 2-14.
- (a) What is the state of the water entering the valve (subcooled liquid, saturated liquid, or vapor)?
- (b) For each kilogram that enters the pressure-reducing valve, how much leaves the separating tank as vapor?

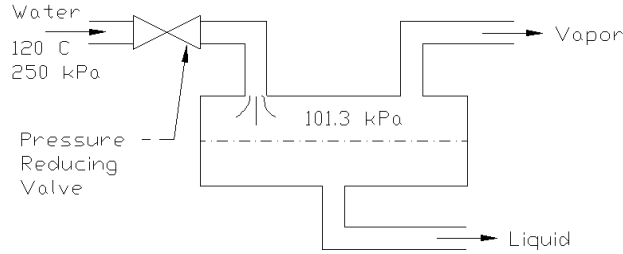

Fig. 2-14. Pressure-reducing valve in Problem 2-1

Solution:

- (a) From Fig. 2-2, a temperature of 120 C and pressure of 250 kPa water lies in the sub-cooled region. so it is a sub-cooled liquid.
- (b) At 120 C, $h_1 = 503.72$ kJ/kg from Table A-1

For Pressuring Reducing Valve $Dh = 0$
 $h_2 = h_1$

At 101.3 kPa, Table A-1, $h_f = 419.06$ kJ/kg
 $h_g = 2676$ kJ/kg

Let x be the amount of vapor leaving the separating tank.

$$h = h_f + x(h_g - h_f)$$

$$x = \frac{h - h_f}{h_g - h_f} = \frac{503.72 - 419.06}{2676 - 419.06}$$

$x = 0.0375$ kg/kg - - - Ans.

- 2-2. Air flowing at a rate of 2.5 kg/s is heated in a heat exchanger from -10 to 30 C. What is the rate of heat transfer?

Solution:

$$q = mc_p(t_2 - t_1)$$

$m = 2.5$ kg/s
 $c_p = 1.0$ kJ/kg.K
 $t_2 = 30$ C
 $t_1 = -10$ C

Then,

$$q = (2.5)(1.0)(30 + 10)$$

q = 100 kw - - - Ans.

2-3. One instrument for measuring the rate of airflow is a venturi, as shown in Fig. 2-15, where the cross-sectional area is reduced and the pressure difference between position A and B measured. The flow rate of air having a density of 1.15 kg/m^3 is to be measured in a venturi where the area of position A is 0.5 m^2 and the area at b is 0.4 m^2 . The deflection of water (density = 1000 kg/m^3) in a manometer is 20 mm. The flow between A and B can be considered to be frictionless so that Bernoulli's equation applies.

- (a) What is the pressure difference between position A and B?
 (b) What is the airflow rate?

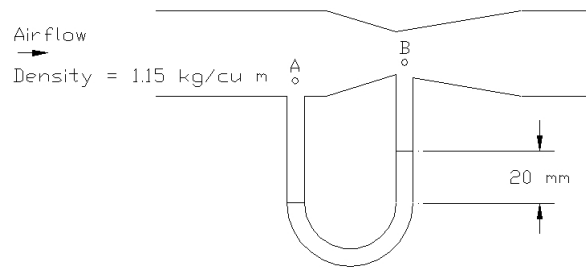

Fig. 2-15. A venturi for measuring air flow.

Solution:

- (a) Bernoulli equation for manometer

$$\frac{p_A}{\rho} + gz_A = \frac{p_B}{\rho} + gz_B$$

$$p_A - p_B = \rho g(z_B - z_A)$$

$$z_B - z_A = 20 \text{ mm} = 0.020 \text{ m}$$

$$g = 9.81 \text{ m/s}^2$$

$$\rho = 1000 \text{ kg/m}^3$$

$$p_A - p_B = (1000 \text{ kg/m}^3)(9.81 \text{ m/s}^2)(0.020 \text{ m})$$

$p_A - p_B = 196.2 \text{ Pa}$ - - - Ans.

- (b) Bernoulli Equation for Venturi

$$\frac{p}{\rho} + \frac{V^2}{2} = \text{constant}$$

$$\frac{p_A}{\rho} + \frac{V_A^2}{2} = \frac{p_B}{\rho} + \frac{V_B^2}{2}$$

$$p_A - p_B = \frac{1}{2}\rho(V_B^2 - V_A^2)$$

But $m = \rho A_A V_A = \rho A_B V_B$

$$A_A V_A = A_B V_B$$

$A_A = 0.5 \text{ m}^2$ and $A_B = 0.4 \text{ m}^2$

Then

$$0.5V_A = 0.4V_B$$

$$V_A = 0.8V_B$$

$$p_A - p_B = 196.2 \text{ Pa} = \frac{1}{2}(1.15 \text{ kg/m}^3)[V_B^2 - (0.8V_B)^2]$$

$$V_B = 30.787 \text{ m/s}$$

Air Flow Rate = $A_B V_B$
 = $(0.4 \text{ m}^2)(30.787 \text{ m/s})$
 = **12.32 m³/s --- Ans.**

- 2-4. Use the perfect-gas equation with $R = 462 \text{ J/kg}\cdot\text{K}$ to compute the specific volume of saturated vapor at 20 C. Compare with data of Table A-1.

Solution:

Perfect-Gas Equation:

$$pv = RT$$

$$v = \frac{RT}{p}$$

At 20 C, Table A-1, Saturation Pressure = 2.337 kPa = 2337 Pa.

Specific volume of saturated vapor = 57.84 m³/kg

$$T = 20 \text{ C} + 273 = 293 \text{ K}$$

$$v = \frac{(462 \text{ J/kg}\cdot\text{K})(293 \text{ K})}{2337 \text{ Pa}}$$

$$v = 57.923 \text{ m}^3/\text{kg}$$

$$\text{Deviation} = \frac{57.923 - 57.84}{57.84} (100\%)$$

$$\text{Deviation} = 0.1435 \%$$

- 2-5. Using the relationship shown on Fig. 2-6 for heat transfer when a fluid flows inside tube, what is the percentage increase or decrease in the convection heat-transfer coefficient h_c if the viscosity of the fluid is decreased 10 percent.

Solution:

Figure 2-6.

$$Nu = 0.023Re^{0.8}Pr^{0.4}$$

where:

$$Re = \frac{\rho VD}{\mu}$$

$$Pr = \frac{\mu c_p}{k}$$

$$Nu = \frac{h_c D}{k}$$

Then,

$$\frac{\left(\frac{h_{c1}D}{k}\right)}{\left(\frac{h_{c2}D}{k}\right)} = \frac{0.023\left(\frac{\rho VD}{\mu_1}\right)^{0.8}\left(\frac{\mu_1 c_p}{k}\right)^{0.4}}{0.023\left(\frac{\rho VD}{\mu_2}\right)^{0.8}\left(\frac{\mu_2 c_p}{k}\right)^{0.4}}$$

$$\frac{h_{c1}}{h_{c2}} = \left(\frac{\mu_2}{\mu_1}\right)^{0.4}$$

If viscosity is decreased by 10 %

$$\frac{\mu_2}{\mu_1} = 0.9$$

Then,

$$\frac{h_{c1}}{h_{c2}} = (0.9)^{0.4}$$

$$h_{c2} = 1.043h_{c1}$$

$$\text{Increase} = \frac{h_{c2} - h_{c1}}{h_{c1}} (100\%)$$

$$\text{Increase} = (1.043 - 1)(100 \%)$$

$$\text{Increase} = 4.3 \% \text{ --- Ans.}$$

- 2-6. What is the order of magnitude of heat release by convection from a human body when the air velocity is 0.25 m/s and its temperature is 24 C?

Solution:

Using Eq. (2-12) and Eq. (2-18)

$$C = h_c A (t_s - t_a)$$

$$h_c = 13.5V^{0.6}$$

$$V = 0.25 \text{ m/s}$$

$$h_c = 13.5(0.25)^{0.6} = 5.8762 \text{ W/m}^2 \cdot \text{K}$$

Human Body: $A = 1.5 \text{ to } 2.5 \text{ m}^2$ use 1.5 m^2
 $t_s = 31 \text{ to } 33 \text{ C}$ use 31 C

$$C = (5.8762 \text{ W/m}^2 \cdot \text{K})(1.5 \text{ m}^2)(31 \text{ C} - 24 \text{ C})$$

$$C = 61.7 \text{ W}$$

Order of Magnitude ~ 60 W - - - Ans.

2-7 What is the order of magnitude of radiant heat transfer from a human body in a comfort air-conditioning situation?

Solution:

Eq. 2-10.

$$q_{1-2} = \sigma A F_{\epsilon} F_A (T_1^4 - T_2^4)$$

Surface area of human body = $1.5 \text{ to } 2.5 \text{ m}^2$ use 1.5 m^2

$$A F_{\epsilon} F_A = (1.0)(0.70)(1.5 \text{ m}^2) = 1.05 \text{ m}^2$$

$$s = 5.669 \times 10^{-8} \text{ W/m}^2 \cdot \text{K}^4$$

$$T_1 = 31 \text{ C} + 273 = 304 \text{ K}$$

$$T_2 = 24 \text{ C} + 273 = 297 \text{ K}$$

$$q_{1-2} = (5.669 \times 10^{-8})(1.05)(304^4 - 297^4)$$

$$q_{1-2} = 45 \text{ W}$$

Order of Magnitude ~ 40 W - - - Ans.

2-8. What is the approximate rate of heat loss due to insensible evaporation if the skin temperature is 32 C , the vapor pressure is 4750 Pa , and the vapor pressure of air is 1700 Pa ? The latent heat of water is 2.43 MJ/kg ; $C_{\text{diff}} = 1.2 \times 10^{-9} \text{ kg/Pa} \cdot \text{s} \cdot \text{m}^2$.

Solution:

Equation 2-19.

$$q_{\text{ins}} = h_{\text{fg}} A C_{\text{diff}} f(p_s - p_a)$$

Where:

$A = 2.0 \text{ m}^2$ average for human body area

$h_{\text{fg}} = 2.43 \text{ MJ/kg} = 2,430,000 \text{ J/kg}$

$p_s = 4750 \text{ Pa}$

$p_a = 1700 \text{ Pa}$

$C_{\text{diff}} = 1.2 \times 10^{-9} \text{ kg/Pa} \cdot \text{s} \cdot \text{m}^2$

$$q_{\text{ins}} = (2,430,000)(2.0)(1.2 \times 10^{-9})(4750 - 1700)$$

$q_{\text{ins}} = 18 \text{ W} - - - \text{Ans.}$

- 0 0 0 -

- 3-1 Calculate the specific volume of an air-vapor mixture in cubic meters per kilogram of dry air when the following conditions prevail: $t = 30\text{ C}$, $W = 0.015\text{ kg/kg}$, and $p_t = 90\text{ kPa}$.

Solution:

Equation 3-4.

$$v = \frac{R_a T}{p_a} = \frac{R_a T}{p_t - p_s}$$

$$T = 30\text{ C} + 273 = 303\text{ K}$$

$$R_a = 287\text{ J/kg.K}$$

$$P_t = 90\text{ kPa} = 90,000\text{ Pa}$$

Equation 3-2

$$W = \frac{0.622p_s}{p_t - p_s}$$

$$0.015 = \frac{0.622p_s}{90 - p_s}$$

$$1.35 - 0.15p_s = 0.622p_s$$

$$p_s = 2.1193\text{ kPa}$$

$$v = \frac{R_a T}{p_t - p_s} = \frac{(287)(303)}{90000 - 2119.3}$$

$$v = 0.99\text{ m}^3/\text{kg} \text{ --- Ans.}$$

- 3-2. A sample of air has a dry-bulb temperature of 30 C and a wet-bulb temperature of 25 C . The barometric pressure is 101 kPa . Using steam tables and Eqs. (3-2), (3-3), and (3-5), calculate (a) the humidity ratio if this air is adiabatically saturated, (b) the enthalpy of air if it is adiabatically saturated, (c) the humidity ratio of the sample using Eq. (3-5), (d) the partial pressure of water vapor in the sample, and (e) the relative humidity.

Solution:

Eq. 3-2.

$$W = \frac{0.622p_s}{p_t - p_s}$$

Eq. 3-3.

$$h = c_p t + W h_g$$

Eq. 3-5

$$h_1 = h_2 - (W_2 - W_1)h_f$$

$$h_1 = c_p t_1 + W h_{g1}$$

$$h_{g1} \text{ at } 30\text{ C} = 2556.4\text{ kJ/kg}$$

$$t_1 = 30\text{ C}$$

$$c_p = 1.0\text{ kJ/kg.K}$$

$$h_1 = (1)(30) + 2556.4W_1$$

$$h_1 = 30 + 2556.4W_1$$

$$h_2 = c_p t_2 + W h_{g2}$$

$$h_{g2} \text{ at } 25 \text{ C} = 2547.3 \text{ kJ/kg}$$

$$t_2 = 25 \text{ C}$$

$$c_p = 1.0 \text{ kJ/kg.K}$$

$$h_2 = (1)(25) + 2547.3W_2$$

$$h_2 = 25 + 2547.3W_2$$

$$h_1 \text{ at } 25 \text{ C} = 104.77 \text{ kJ/kg}$$

Then:

$$h_1 = h_2 - (W_2 - W_1)h_f$$

$$30 + 2556.4W_1 = 25 + 2547.3W_2 - (W_2 - W_1)(104.77)$$

$$5 = 2442.53W_2 - 2451.63W_1$$

But,

$$W_2 = \frac{0.622p_s}{p_t - p_s}$$

$$p_s \text{ at } 25 \text{ C} = 3.171 \text{ kPa}$$

$$W_2 = \frac{0.622(3.171)}{101 - 3.171}$$

$$W_2 = 0.0201 \text{ kg/kg}$$

$$5 = 2442.53(0.0201) - 2451.63W_1$$

$$W_1 = 0.018 \text{ kg/kg}$$

(a) Humidity Ratio
 $W_2 = 0.0201 \text{ kg/kg} \text{ --- Ans.}$

(b) $h_2 = c_p t_2 + W_2 h_{g2}$
 $h_2 = (1)(25) + (0.0201)(2547.3)$
 $h_2 = 76.2 \text{ kJ/kg} \text{ --- Ans.}$

(c) Humidity Ratio
 $W_1 = 0.018 \text{ kg/kg} \text{ --- Ans.}$

(d) p_{s1}
 $W_1 = \frac{0.622p_s}{p_t - p_s}$
 $0.018 = \frac{0.622p_s}{101 - p_s}$
 $p_{s1} = 2.84 \text{ kPa}$
 $p_{s1} = 2840 \text{ kPa} \text{ --- Ans.}$

(e) At 30 C, $p_s = 4.241$ kPa

$$\text{Relative Humidity} = (2.84 \text{ kPa} / 4.241 \text{ kPa})(100\%)$$

Relative Humidity = 67 % - - - Ans.

3-3 Using humidity ratios from the psychrometric chart, calculate the error in considering the wet-bulb line to be the line of constant enthalpy at the point of 35 C dry-bulb temperature and 50 percent relative humidity.

Solution:

Dry-bulb Temperature = 35 C

Relative Humidity = 50 %

Fig. 3-1, Psychrometric Chart.

At constant enthalpy line: Wet-bulb = 26.04 C

At wet-bulb line = Wet-bulb = 26.17 C

$$\text{Error} = 26.17 \text{ C} - 26.04 \text{ C}$$

$$\text{Error} = 0.13 \text{ C}$$

3-4. An air-vapor mixture has a dry-bulb temperature of 30 C and a humidity ratio of 0.015. Calculate at two different barometric pressures, 85 and 101 kPa, (a) the enthalpy and (b) the dew-point temperature.

Solution:

At 30 C, $p_s = 4.241$ kPa, $h_g = 2556.4$ kJ/kg

$$(a) \quad h = c_p t + W h_g$$

For 85 and 101 kPa

$$c_p = 1.0$$

$$t = 30 \text{ C}$$

$$W = 0.015 \text{ kg/kg}$$

$$h_g = 2556.4 \text{ kJ/kg}$$

$$h = (1.0)(30) + (0.015)(2556.4)$$

$$h = 68.3 \text{ kJ/kg}$$

(b) For dew-point:

$$W = \frac{0.622 p_s}{p_t - p_s}$$

at 85 kPa

$$0.015 = \frac{0.622 p_s}{p_t - p_s}$$

$$p_s = 2.0016 \text{ kPa}$$

Dew-Point = 17.5 C - - - Ans.

at 101 kPa

$$0.015 = \frac{0.622p_s}{p_t - p_s}$$

$$p_s = 2.3783 \text{ kPa}$$

Dew-Point = 20.3 C - - - Ans.

- 3-5. A cooling tower is a device that cools a spray of water by passing it through a stream of air. If $15 \text{ m}^3/\text{s}$ of air is at 35 C dry-bulb and 24 C wet-bulb temperature and an atmospheric pressure of 101 kPa enters the tower and the air leaves saturated at 31 C , (a) to what temperature can this airstream cool a spray of water entering at 38 C with a flow rate of 20 kg/s and (b) how many kilograms per second of make-up water must be added to compensate for the water that is evaporated?

Solution:

At 35 C dry-bulb, 24 C wet-bulb.

Fig. 3-1, Psychrometric Chart

$$h_1 = 71.524 \text{ kJ/kg,}$$

$$v_1 = 0.89274 \text{ m}^3/\text{kg}$$

$$W_1 = 0.0143 \text{ kg/kg}$$

At 31 C saturated, Table A-2.

$$h_2 = 105 \text{ kJ/kg}$$

$$W_2 = 0.0290 \text{ kg/kg}$$

Then;

$$m = (15 \text{ m}^3/\text{s}) / (0.89274 \text{ m}^3/\text{kg}) = 16.8022 \text{ kg/s}$$

(a) $t_{w1} = 38 \text{ C}$
 $m_w = 20 \text{ kg/s}$
 $c_{pw} = 4.19 \text{ kJ/kg.K}$

$$m_w c_{pw} (t_{w1} - t_{w2}) = m(h_2 - h_1)$$

$$(20)(4.19)(38 - t_{w2}) = (16.8022)(105 - 71.524)$$

$t_{w2} = 31.3 \text{ C} - - - \text{Ans.}$

(b) Make-Up Water = m_m

$$m_m = m(W_2 - W_1)$$

$$m_m = (16.8022)(0.0290 - 0.0143)$$

$m_m = 0.247 \text{ kg/s} - - - \text{Ans.}$

- 3-6. In an air-conditioning unit $3.5 \text{ m}^3/\text{s}$ of air at 27 C dry-bulb temperature, 50 percent relative humidity, and

standard atmospheric pressure enters the unit. The leaving condition of the air is 13 C dry-bulb temperature and 90 percent relative humidity. Using properties from the psychrometric chart, (a) calculate the refrigerating capacity in kilowatts and (b) determine the rate of water removal from the air.

Solution:

At 27 C dry-bulb, 5 Percent Relative Humidity

$$h_1 = 55.311 \text{ kJ/kg,}$$

$$v_1 = 0.86527 \text{ m}^3/\text{kg}$$

$$W_1 = 0.0112 \text{ kg/kg}$$

At 13 C Dry-Bulb, 90 Percent Relative Humidity

$$h_2 = 33.956 \text{ kJ/kg}$$

$$W_2 = 0.0084 \text{ kg/kg}$$

$$m = (3.5 \text{ m}^3/\text{s}) / (0.86526 \text{ m}^3/\text{kg}) = 4.04498 \text{ kg/s}$$

$$\begin{aligned} \text{(a) Refrigerating Capacity} \\ &= m(h_1 - h_2) \\ &= (4.04498)(55.311 - 33.956) \\ &= \mathbf{86.38 \text{ kW} \text{ --- Ans.}} \end{aligned}$$

$$\begin{aligned} \text{(b) Rate of Water Removal} \\ &= m(W_1 - W_2) \\ &= (4.04498)(0.0112 - 0.0084) \\ &= \mathbf{0.0113 \text{ kg/s} \text{ --- Ans.}} \end{aligned}$$

- 3-7. A stream of outdoor air is mixed with a stream of return air in an air-conditioning system that operates at 101 kPa pressure. The flow rate of outdoor air is 2 kg/s, and its condition is 35 C dry-bulb temperature and 25 C wet-bulb temperature. The flow rate of return air is 3 kg/s, and its condition is 24 C and 50 percent relative humidity. Determine (a) the enthalpy of the mixture, (b) the humidity ratio of the mixture, (c) the dry-bulb temperature of the mixture from the properties determined in parts (a) and (b) and (d) the dry-bulb temperature by weighted average of the dry-bulb temperatures of the entering streams.

Solutions:

Use Fig. 3-1, Psychrometric Chart

At 35 C Dry-Bulb, 24 C Wet-Bulb

$$h_1 = 75.666 \text{ kJ/kg, } m_1 = 2 \text{ kg/s}$$

$$W_1 = 0.0159 \text{ kg/kg}$$

At 24 C Dry-Bulb, 50 Percent Relative Humidity

$$h_2 = 47.518 \text{ kJ/kg, } m_2 = 3 \text{ kg/s}$$

$$W_2 = 0.0093 \text{ kg/kg}$$

(a)

$$\begin{aligned} h_m &= \frac{(2)(75.666) + (3)(47.518)}{2 + 3} \\ h_m &= \mathbf{58.777 \text{ kJ/kg} \text{ --- Ans.}} \end{aligned}$$

(b)

$$W_m = \frac{(2)(0.0159) + (3)(0.0093)}{2 + 3}$$

$W_m = 0.1194 \text{ kg/kg} \text{ --- Ans.}$

(c) At 58.777 kJ/kg and 0.01194 kg/kg.
From Psychrometric Chart, Fig. 3-1.

Dry-Bulb Temperature = 28.6 C --- Ans.

(d)

$$t_m = \frac{(2)(35) + (3)(24)}{2 + 3}$$

$t_m = 28.4 \text{ C} \text{ --- Ans.}$

3-8. The air conditions at the intake of an air compressor are 28 C, 50 percent relative humidity, and 101 kPa. The air is compressed to 400 kPa, then sent to an intercooler. If condensation of water vapor from the compressed air is to be prevented, what is the minimum temperature to which the air can be cooled in the intercooler?

Solution: At 28 C, $p_s = 3.778 \text{ kPa}$

At 50 percent relative humidity, $p_s = (0.5)(3.778 \text{ kPa}) = 1.889 \text{ kPa}$

$$W = \frac{0.622p_s}{p_t - p_s}$$

Moisture ratio is constant

at 101 kPa

$$W = \frac{0.622(1.889)}{101 - 1.889}$$

$W = 0.011855 \text{ kg/kg}$

at 400 kPa, determine p_s

$$0.011855 = \frac{0.622p_s}{400 - p_s}$$

$p_s = 7.4812 \text{ kPa}$

From Table A-1.

Dew-Point = 40.3 C --- Ans.

- 3-9. A winter air-conditioning system adds for humidification 0.0025 kg/s of saturated steam at 101 kPa pressure to an airflow of 0.36 kg/s. The air is initially at a temperature of 15 C with a relative humidity of 20 percent. What are the dry- and wet-bulb temperatures of the air leaving the humidifier?

Solution:

At 15 C Dry-Bulb, 20 Percent Relative Humidity

$$h_1 = 20.021 \text{ kJ/kg}$$

$$W_1 = 0.0021 \text{ kg/kg}$$

At 101 kPa steam, $h_{fg} = 2675.85 \text{ kJ/kg}$

$$m_s = 0.0025 \text{ kg/s}$$

$$m = 0.36 \text{ kg/s}$$

$$m_s = m(W_2 - W_1)$$

$$0.0025 = 0.36(W_2 - 0.0021)$$

$$W_2 = 0.00894 \text{ kg/kg}$$

$$m(h_2 - h_1) = m_s h_g$$

$$(0.36)(h_2 - 20.021) = (0.0025)(2675.85)$$

$$h_2 = 38.6 \text{ kJ/kg}$$

Fig. 3-1, Psychrometric Chart

$$W_2 = 0.00894 \text{ kg/kg}$$

$$h_2 = 38.6 \text{ kJ/kg}$$

Dry-Bulb Temperature = 16.25 C

Wet-Bulb Temperature = 13.89 C

- 3-10. Determine for the three cases listed below the magnitude in watts and the direction of transfer of sensible heat [using Eq. (3-8)], latent heat [using Eq. (3-9)], and total heat [using Eq. (3-14)]. the area is 0.15 m² and $h_c = 30 \text{ W/m}^2 \cdot \text{K}$. Air at 30 C and 50 percent relative humidity is in contact with water that is at a temperature of (a) 13 C, (b) 20 C, and (c) 28 C.

Solution:

Equation 3-8.

$$dq_s = h_c dA(t_i - t_a)$$

Equation 3-9.

$$dq_L = h_D dA(W_i - W_a)h_{fg}$$

Equation 3-14.

$$dq_t = \frac{h_c dA}{C_{pm}}(h_i - h_a)$$

At 30 C, 50% Relative Humidity

$$h_a = 63.965 \text{ kJ/kg} = 63,965 \text{ J/kg}$$

$$W_a = 0.0134 \text{ kg/kg}$$

(a) 13 C

$$dq_s = h_c dA(t_i - t_a)$$

$$dq_s = (30)(0.15)(13 - 30)$$

$dq_s = -76.5 \text{ W} \text{ --- Ans.}$

$$dq_L = h_D dA(W_i - W_a)h_{fg}$$

W_i at 13 C = 0.00937 kg/kg from Table A-2

h_{fg} at 13 C = 2,470,840 J/kg

$$h_D = h_c / c_{pm}$$

$$c_{pm} = 1020 \text{ kJ/kg.K}$$

$$h_D = 30 / 1020 = 0.029412$$

$$dq_L = (0.029412)(0.15)(0.00937 - 0.0134)(2,470,840)$$

$dq_L = -43.93 \text{ W} \text{ --- Ans.}$

h_i at 13 C = 36,719 J/kg from Table A-2

$$dq_t = \frac{h_c dA}{c_{pm}}(h_i - h_a) = \frac{(30)(0.15)}{1020}(36,719 - 63,965)$$

$dq_t = -120.2 \text{ W} \text{ --- Ans.}$

(b) 20 C

$$dq_s = h_c dA(t_i - t_a)$$

$$dq_s = (30)(0.15)(20 - 30)$$

$dq_s = -45 \text{ W} \text{ --- Ans.}$

$$dq_L = h_D dA(W_i - W_a)h_{fg}$$

W_i at 20 C = 0.01475 kg/kg from Table A-2

h_{fg} at 20 C = 2,454,340 J/kg

$$h_D = h_c / c_{pm}$$

$$c_{pm} = 1020 \text{ kJ/kg.K}$$

$$h_D = 30 / 1020 = 0.029412$$

$$dq_L = (0.029412)(0.15)(0.01475 - 0.0134)(2,454,340)$$

$dq_L = 14.62 \text{ W} \text{ --- Ans.}$

h_i at 20 C = 57,544 J/kg from Table A-2

$$dq_t = \frac{h_c dA}{c_{pm}}(h_i - h_a) = \frac{(30)(0.15)}{1020}(57,544 - 63,965)$$

$dq_t = -28.33 \text{ W} \text{ --- Ans.}$

(c) 28 C

$$dq_s = h_c dA(t_i - t_a)$$

$$dq_s = (30)(0.15)(28 - 30)$$

$dq_s = -9.0 \text{ W} \text{ --- Ans.}$

$$dq_L = h_D dA (W_i - W_a) h_{fg}$$

W_i at 28 C = 0.02422 kg/kg from Table A-2

h_{fg} at 28 C = 2,435,390 J/kg

$$h_D = h_c / c_{pm}$$

$$c_{pm} = 1020 \text{ kJ/kg.K}$$

$$h_D = 30 / 1020 = 0.029412$$

$$dq_L = (0.029412)(0.15)(0.02422 - 0.0134)(2,435,390)$$

$$dq_L = 116.3 \text{ W} \text{ --- Ans.}$$

h_i at 28 C = 89,952 J/kg from Table A-2

$$dq_t = \frac{h_c dA}{c_{pm}} (h_i - h_a) = \frac{(30)(0.15)}{1020} (89,952 - 63,965)$$

$$dq_t = 114.6 \text{ W} \text{ --- Ans.}$$

- 0 0 0 -

- 4-1 The exterior wall of a single-story office building near Chicago is 3 m high and 15 m long. The wall consists of 100-mm facebrick, 40-mm polystyrene insulating board, 150-mm lightweight concrete block, and an interior 16-mm gypsum board. The wall contains three single-glass windows 1.5 m high by 2 m long. Calculate the heat loss through the wall at design conditions if the inside temperature is 20 C.

Solution:

Table 4-3, Design Outdoor is -18 C for Chicago.

For the wall:

$$\text{Area, } A = (3 \text{ m})(15 \text{ m}) - (3)(1.5 \text{ m})(2 \text{ m}) = 36 \text{ m}^2.$$

Resistance: Table 4-4.

Outside Air Film	0.029
Facebrick, 100 mm	0.076
Polystyrene Insulating Board, 40 mm	1.108
Lightweight Concrete Block, 150 mm	0.291
Gypsum Board, 16 mm	0.100
Inside Air Film	0.120
	=====
R_{tot}	$= 1.724 \text{ m}^2 \cdot \text{K} / \text{W}$

Wall:

$$q = \frac{A}{R_{\text{tot}}} \Delta t = \frac{36}{1.724} (-18 - 20)$$

$$q = -794 \text{ Watts}$$

For the glass:

$$\text{Area } A = (3)(1.5 \text{ m})(2 \text{ m}) = 9 \text{ m}^2$$

Table 4-4, $U = 6.2 \text{ W/m}^2 \cdot \text{K}$

$$q = UA\Delta t = (6.2)(9)(-18 - 20)$$

$$q = -2,120 \text{ Watts}$$

$$\begin{aligned} \text{Total Heat Loss Thru the Wall} &= -794 \text{ W} - 2,120 \text{ W} \\ &= \mathbf{-2,194 \text{ Watts} \text{ --- Ans}} \end{aligned}$$

- 4-2. For the wall and conditions stated in Prob. 4-1 determine the percent reduction in heat loss through the wall if (a) the 40 mm of polystyrene insulation is replaced with 55 mm of cellular polyurethane, (b) the single-glazed windows are replaced with double-glazed windows with a 6-mm air space. (c) If you were to choose between modification (a) or (b) to upgrade the thermal resistance of the wall, which would you choose and why?

Solution

(a)	Resistance: Table 4-4	
	Outside Air Film	0.029
	Facebrick, 100 mm	0.076
	Cellular Polyurethane, 55 mm	2.409
	Lightweight Concrete Block, 150 mm	0.291
	Gypsum Board, 16 mm	0.100
	Inside Air Film	0.120
		=====
	R_{tot}	$= 3.025 \text{ m}^2 \cdot \text{K} / \text{W}$

Wall:

$$q = \frac{A}{R_{tot}} \Delta t = \frac{36}{3.025} (-18 - 20)$$

$$q = -452 \text{ Watts}$$

New Total Heat Loss Thru Wall

$$q = -452 \text{ W} - 2,120 \text{ W}$$

$$q = -2,572 \text{ W}$$

$$\% \text{Reduction} = \frac{(-2,914 \text{ W}) - (-2,572 \text{ W})}{-2,914 \text{ W}} (100 \%)$$

% Reduction = 11.74 % - - Ans.

(b) For the glass: (Double-Glazed)

Table 4-4, $U = 3.3 \text{ W/m}^2 \cdot \text{K}$

$$q = UA\Delta t = (3.3)(9)(-18 - 20)$$

$$q = -1,129 \text{ Watts}$$

New Total Heat Loss Thru Wall

$$q = -794 \text{ W} - 1,129 \text{ W}$$

$$\% \text{Reduction} = \frac{(-2,914 \text{ W}) - (-1,923 \text{ W})}{-2,914 \text{ W}} (100 \%)$$

% Reduction = 34 % - - Ans.

(c) **Choose letter b --- Ans.**

4-3 An office in Houston, Texas, is maintained at 25 C and 55 percent relative humidity. The average occupancy is five people, and there will be some smoking. Calculate the cooling load imposed by ventilation requirements at summer design conditions with supply air conditions set at 15 C and 95 percent relative humidity if (a) the recommended rate of outside ventilation air is used and (b) if a filtration device of $E = 70$ percent is used.

Solution:

Table 4-3, Houston Texas

Summer Design Conditions

Dry-Bulb = 34 C

Wet-Bulb = 25 C

At 34 C Dry-Bulb, 24 C Wet-Bulb

$$h_o = 76 \text{ kJ/kg}, W_o = 0.0163 \text{ kg/kg}$$

At 15 C Dry-Bulb, 95 percent relative humidity

$$h_s = 40.5 \text{ kJ/kg}, W_s = 0.010 \text{ kg/kg}$$

At 25 C, 55 percent relative humidity

$$h_i = 53.2 \text{ kJ/kg}, W_i = 0.011 \text{ kg/kg}$$

(a) $V = V_o$

Table 4-1, 10 L/s per person

$$V = (10 \text{ L/s})(5) = 50 \text{ L/s}$$

$$q_s = 1.23V(t_o - t_s)$$

$$q_s = 1.23(50)(34 - 15)$$

$$q_s = 1,168.5 \text{ W}$$

$$q_L = 3000V(W_o - W_i)$$

$$q_L = 3000(50)(0.0163 - 0.010)$$

$$q_L = 945 \text{ W}$$

$$q_t = q_s + q_L$$

$$q_t = 1,168.5 \text{ W} + 945 \text{ W}$$

$$q_t = 2,113.5 \text{ W}$$

$$q_t = 2.1 \text{ kw} \text{ --- Ans.}$$

(a) $V_1 = V_m$

Table 4-1, 2.5 L/s per person

$$V_1 = (2.5 \text{ L/s})(5) = 12.5 \text{ L/s}$$

$$V_2 = V_r = \frac{V_o - V_m}{E}$$

$$V_2 = \frac{50 - 12.5}{0.7}$$

$$V_2 = 53.5714 \text{ L/s}$$

$$q_s = 1.23V_1(t_o - t_s) + 1.23V_2(t_1 - t_s)$$

$$q_s = 1.23(12.5)(34 - 15) + 1.23(53.5714)(25 - 15)$$

$$q_s = 951 \text{ W}$$

$$q_L = 3000V_1(W_o - W_s) + 3000V_2(W_i - W_s)$$

$$q_L = 3000(12.5)(0.0163 - 0.010) + 3000(53.5714)(0.011 - 0.010)$$

$$q_L = 397 \text{ W}$$

$$q_t = q_s + q_L$$

$$q_t = 951 \text{ W} + 397 \text{ W}$$

$$q_t = 1,348 \text{ W}$$

$$q_t = 1.35 \text{ kw} \text{ --- Ans.}$$

4-4 A computer room located on the second floor of a five-story office building is 10 by 7 m. The exterior wall is 3.5 m high and 10 m long; it is a metal curtain wall (steel backed with 10 mm of insulating board), 75 mm of glass-fiber insulation, and 16 mm of gypsum board. Single-glazed windows make up 30 percent of the exterior wall. The computer and lights in the room operate 24 h/d and have a combined heat release to the space of 2 kw. The indoor temperature is 20 C.

(a) If the building is located in Columbus, Ohio, determine the heating load at winter design conditions.

(b) What would be the load if the windows were double-glazed?

Solution:

(a) Table 4-3, Columbus, Ohio, Winter Design Temperature = -15 C.

Thermal Transmission:

Wall:

$$q = \frac{A}{R_{tot}} (t_o - t_i)$$

$$A = (3.5 \text{ m})(10 \text{ m})(0.70) = 24.5 \text{ m}^2$$

Table 4-4:

Outside Air Film	0.029
Insulating Board, 10 mm	0.320
Glass-Fiber Insulation, 75 mm	2.0775
Gypsum Board, 16 mm	0.100
Inside Air Film	0.120
	====

$$R_{tot} = 2.6465 \text{ m}^2 \cdot \text{K/W}$$

$$q_w = \frac{24.5}{2.6465} (-15 - 20)$$

$$q_w = -324 \text{ W}$$

Glass:

$$q = UA(t_o - t_i)$$

$$A = (3.5 \text{ m})(10 \text{ m})(0.30) = 10.5 \text{ m}^2$$

Table 4-4.

Single Glass, $U = 6.2 \text{ W/m}^2 \cdot \text{K}$

$$q_G = (6.2)(10.5)(-15 - 20)$$

$$q_G = -2,278.5 \text{ W}$$

$$q_t = -324 \text{ W} - 2,278.5 \text{ W} = -2,602.5 \text{ W}$$

Heating Load = 2,602.5 W - 2,000 W

Heating Load = 602.5 W - - - Ans.

(b) If double-glazed, Say 6-mm air space

Table 4-4, $U = 3.3 \text{ W/m}^2 \cdot \text{K}$

$$q_G = (3.3)(10.5)(-15 - 20)$$

$$q_G = -1,212.8 \text{ W}$$

$$q_t = -324 \text{ W} - 1,212.8 \text{ W} = -1,536.8 \text{ W}$$

Since 1,536.8 W < 2,000 W, there is no additional heat load required.

- 4-5. Compute the heat gain for a window facing southeast at 32° north latitude at 10 A.M. central daylight time on August 21. The window is regular double glass with a 13-mm air space. The glass and inside draperies have a combined shading coefficient of 0.45. The indoor design temperature is 25 C, and the outdoor temperature is 37 C. Window dimensions are 2 m wide and 1.5 m high.

Solution:

$$\text{Window Area} = 2 \text{ m} \times 1.5 \text{ m} = 3.0 \text{ m}^2$$

Table 4-4, $U = 3.5 \text{ W/m}^2 \cdot \text{K}$

Transmission:

$$q_1 = UA(t_o - t_i)$$

$$q_1 = (3.5)(3)(37 - 25)$$

$$q_1 = 126 \text{ W}$$

Solar:

$$q_{sg} = (\text{SHGFmax})(\text{SC})(\text{CLF})A$$

Table 4-10, 32° North Latitude, Facing SE

$$\text{SHGF} = 580 \text{ W/m}^2$$

Table 4-12, Facing SE at 10 A.M.

$$\text{CLF} = 0.79$$

and SC = 0.45

$$q_{sg} = (580)(0.45)(0.79)(3)$$

$$q_{sg} = 618.6 \text{ W}$$

$$\text{Heat Gain} = 126 \text{ W} + 618.6 \text{ W}$$

$$\text{Heat Gain} = 744.6 \text{ W} \text{ --- Ans.}$$

- 4-6. The window in Prob. 4-5 has an 0.5-m overhang at the top of the window. How far will the shadow extend downward?

Solution:

From Fig. 4-5

$$y = d \frac{\tan \beta}{\cos \gamma}$$

$$d = 0.5 \text{ m}$$

Table 4-3, 32° North Latitude, 10 A.M., August

$$\beta = 56^\circ$$

$$\phi = 60^\circ$$

Facing South East, $\psi = 45^\circ$

$$\gamma = \phi - \psi = 60 - 45 = 15^\circ$$

$$y = d \frac{\tan \beta}{\cos \gamma} = (0.5 \text{ m}) \frac{\tan 56^\circ}{\cos 15^\circ}$$

$$y = 0.77 \text{ m} \text{ --- Ans.}$$

- 4-7. Compute the instantaneous heat gain for the window in Prob. 4-5 with the external shade in Prob. 4-6.

Solution:

$$A_1 = \text{Sunlit Area} = (2.0 \text{ m})(1.5 \text{ m} - 0.77 \text{ m}) = 1.46 \text{ m}^2$$

$$A = 3.0 \text{ m}^2$$

$$\begin{aligned}\text{Transmission} &= UA(t_o - t_i) \\ &= (3.5)(3)(37 - 25) \\ &= 126 \text{ W}\end{aligned}$$

Solar:

$$\begin{aligned}q_{sg} &= (\text{SHGF}_{\text{max}})(\text{SC})(\text{CLF})A_i \\ q_{sg} &= (580)(0.45)(0.79)(1.46) = 301 \text{ W}\end{aligned}$$

$$\text{Heat Gain} = 126 \text{ W} + 301 \text{ W} = 427 \text{ W} \text{ --- Ans.}$$

- 4-8. Compute the total heat gain for the south windows of an office building that has no external shading. The windows are double-glazed with a 6-mm air space and with regular plate glass inside and out. Draperies with a shading coefficient of 0.7 are fully closed. Make Calculation for 12 noon in (a) August and (b) December at 32° North Latitude. The total window area is 40 m². Assume that the indoor temperatures are 25 and 20 C and that the outdoor temperatures are 37 and 4 C.

Solution:

Table 4-7
Double-glazed, 6-mm air space, U-value
Summer - 3.5 W/m².K
Winter - 3.3 W/m².K

$$A = 40 \text{ m}^2$$

(a) August, Summer, Indoor = 25 C, Outdoor = 37 C

Thermal Transmission:

$$\begin{aligned}q_1 &= UA(t_o - t_i) \\ q_1 &= (3.5)(40)(37 - 25)\end{aligned}$$

$$q_1 = 1,680 \text{ W}$$

Solar:

$$q_{sg} = (\text{SHGF}_{\text{max}})(\text{SC})(\text{CLF})A$$

Table 4-10, 32° North Latitude, Facing South

$$\text{SHGF} = 355 \text{ W/m}^2$$

Table 4-12, Facing South at 12 Noon.

$$\text{CLF} = 0.83$$

and SC = 0.7

$$\begin{aligned}q_{sg} &= (355)(0.7)(0.83)(40) \\ q_{sg} &= 8,250 \text{ W}\end{aligned}$$

$$\begin{aligned}q_t &= q_1 + q_{sg} \\ q_t &= 1,680 \text{ W} + 8,250 \text{ W} \\ q_t &= 9,930 \text{ W} \text{ --- Ans.}\end{aligned}$$

(b) December, Winter, Indoor = 20 C, Outdoor = 4 C

Thermal Transmission:

$$q_1 = UA(t_o - t_i)$$

$$q_1 = (3.3)(40)(4 - 20)$$

$$q_1 = -2,112 \text{ W}$$

Solar:

$$q_{sg} = (\text{SHGFmax})(\text{SC})(\text{CLF})A$$

Table 4-10, 32° North Latitude, Facing South, December

$$\text{SHGF} = 795 \text{ W/m}^2$$

Table 4-12, Facing South at 12 Noon.

$$\text{CLF} = 0.83$$

and SC = 0.7

$$q_{sg} = (795)(0.7)(0.83)(40)$$

$$q_{sg} = 18,476 \text{ W}$$

$$q_t = q_1 + q_{sg}$$

$$q_t = -2,112 \text{ W} + 18,476 \text{ W}$$

$$q_t = \mathbf{16,364 \text{ W} \text{ --- Ans.}}$$

- 4-9. Compute the instantaneous heat gain for the south wall of a building at 32° north latitude on July 21. The time is 4 p.m. sun time. The wall is brick veneer and frame with an overall heat-transfer coefficient of 0.35 W/m².K. The wall is 2.5 by 6 m with a 1- x 2-m window.

Solution:

$$\text{Wall: } A = (2.5 \text{ m})(5 \text{ m}) - (1 \text{ m})(2 \text{ m}) = 10.5 \text{ m}^2$$

$$U = 0.35 \text{ W/m}^2.\text{K}$$

$$q_w = UA(\text{CLTD})$$

Table 4-11, South, Type F, 4 P.M.

$$\text{CLTD} = 22$$

$$q_w = (0.35)(10.5)(22)$$

$$q_w = \mathbf{80.85 \text{ Watts. --- Ans}}$$

- 4-10. Compute the peak instantaneous heat gain per square meter of area for a brick west wall similar to that in Example 4-3. Assume that the wall is located at 40° north latitude. The date is July. What time of the day does the peak occur? The outdoor daily average temperature of 30 C and indoor design temperature is 25 C.

Solution:

$$\text{Ex. 4-3, } U = 0.356 \text{ W/m}^2.\text{K}$$

Table 4-15, Type F, West Wall

$$\text{CLTD}_{\text{max}} = 33 \text{ at } 1900 \text{ h or } 7 \text{ P.M.}$$

$$CLTD_{adj} = CLTD + (25 - T_i) + (T_{av} - 29)$$

$$CLTD_{adj} = 33 + (30 - 29) = 34 \text{ C}$$

$$q_{max} / A = U(CLTD)$$

$$q_{max} / A = (0.356)(34)$$

$$q_{max} / A = 12.1 \text{ W/m}^2 \text{ at 7 P.M. ---- Ans.}$$

- 0 0 0 -

- 5-1 A conditioned space that is maintained at 25 C and 50 percent relative humidity experience a sensible-heat of 80 kW and a latent-heat gain of 34 kW. At what temperature does the load-ratio line intersect the saturation line?

Solution:

$$\text{Load - ratio} = \frac{q_s}{q_s + q_L}$$

$$q_s = 80 \text{ kW}$$

$$q_L = 34 \text{ kW}$$

$$\text{Load - ratio} = \frac{80}{80 + 34}$$

$$\text{Load-ratio} = 0.7018$$

But,

$$\frac{c_p(t_c - t_i)}{h_c - h_i} = \text{Load - ratio}$$

At 25 C, 50 percent relative humidity

$$h_c = 50.5 \text{ kJ/kg}$$

$$\text{Try } t_i = 15 \text{ C}$$

$$\frac{c_p(t_c - t_i)}{h_c - h_i} = 0.7018$$

$$\frac{(1.0)(25 - 15)}{50.5 - h_i} = 0.7018$$

Connecting the two-points gives the load-ratio line which intersects the saturation line at 9.75 C with $h_i = 28.76 \text{ kJ/kg}$.

Ans. **9.75 C**.

- 5-2. A conditioned space receives warm, humidified air during winter air conditioning in order to maintain 20 C and 30 percent relative humidity. The space experiences an infiltration rate of 0.3 kg/s of outdoor air and an additional sensible-heat loss of 25 kW. The outdoor air is saturated at a temperature of -20 C (see Table A-2). If conditioned air is supplied at 40 C dry-bulb, what must be the wet-bulb temperature of supply air be in order to maintain the space conditions?

Solution:

At -20 saturated,

$$h_1 = -18.546 \text{ kJ/kg}$$

$$m_1 = 0.3 \text{ kg/s}$$

Additional heat loss = 25 kW

At 20 C and 30 percent relative humidity,
 $h_2 = 31$ kJ/kg

$t_3 = 40$ C

Equations:

Sensible Heat Balance:

$$m_2(t_3 - t_2) + m_1(t_1 - t_2) = 25 \text{ kW}$$

$$m_2(40 - 20) + (0.3)(-20 - 20) = 25$$

$$m_2 = 1.85 \text{ kg/s}$$

Total Heat Balance:

$$m_2(h_3 - h_2) + m_1(h_1 - h_2) = 25 \text{ kW}$$

$$(1.85)(h_3 - 31) + (0.3)(-18.546 - 31) = 25$$

$$h_3 = 52.55 \text{ kJ/kg}$$

Then at 40 C and 52.55 kJ/kg.

Wet-Bulb Temperature = 18.8 C - - - Ans.

- 5-3. A laboratory space to be maintained at 24 C and 50 percent relative humidity experiences a sensible-cooling load of 42 kW and a latent load of 18 kW. Because the latent load is heavy, the air-conditioning system is equipped for reheating the air leaving the cooling coil. The cooling coil has been selected to provide outlet air at 9.0 C and 95 percent relative humidity. What is (a) the temperature of supply air and (b) the airflow rate?

Solution:

$$q_s = 42 \text{ kW}$$

$$q_L = 18 \text{ kW}$$

At 24 C , 50 percent relative humidity

$$h_i = 47.5 \text{ kJ/kg}$$

At 9.0 C, 95 percent relative humidity

$$h_c = 26 \text{ kJ/kg}$$

$$\text{Coil load - ratio line} = \frac{c_p(t_c - t_i)}{h_c - h_i}$$

$$\text{Coil load - ratio line} = \frac{(1.0)(9 - 24)}{26 - 47.5} = 0.70$$

$$\text{Coil load - ratio line} = \frac{q_s}{q_s + q_L} = \frac{42}{42 + 18} = 0.70$$

- (a) Since 9 C < 13 C minimum.
 Temperature of supply air = **13 C - - - Ans.**

(b)

$$m = \frac{q_s}{1.0(t_1 - t_2)} = \frac{42}{(1.0)(24 - 13)}$$

m = 3.82 kg/s - - - - Ans.

- 5-4. In discussing outdoor-air control Sec. 5-3 explained that with outdoor conditions in the X and Y regions on the psychrometric chart in Fig. 5-5 enthalpy control is more energy-efficient. We now explore some limitations of that statement with respect to the Y region. Suppose that the temperature setting of the outlet air from the cooling coil is 10 C and that the outlet air is essentially saturated when dehumidification occurs in the coil. If the condition of return air is 24 C and 40 percent relative humidity and the outdoor conditions are 26 C and 30 percent relative humidity, would return air or outside air be the preferred choice? Explain why.

Solution:

See Fig. 5-5 and Sec. 5-3.

Outside Air: At 26 C, 30 percent relative humidity

$$h_o = 42 \text{ kJ/kg}$$

Coil outlet = 10 C saturated

$$q = 42 \text{ kJ/kg} - 29.348 \text{ kJ/kg}$$

$$q = 12.652 \text{ kJ/kg}$$

Recirculated air: At 24 C, 40 percent relative humidity

$$h_i = 43 \text{ kJ/kg}$$

With 10% outdoor air.

$$h_m = (0.10)(42) + (0.90)(43) = 42.9 \text{ kJ/kg}$$

$$q = 42.9 \text{ kJ/kg} - 29.348 \text{ kJ/kg}$$

$$q = 13.552 \text{ kJ/kg} > 12.652 \text{ kJ/kg.}$$

Ans. Outside air is preferred due to lower cooling required.

- 5-5. A terminal reheat system (Fig. 5-9) has a flow rate of supply air of 18 kg/s and currently is operating with 3 kg/s of outside air at 28 C and 30 percent relative humidity. The combined sensible load in the spaces is 140 kw, and the latent load is negligible. The temperature of the supply air is constant at 13 C. An accountant of the firm occupying the building was shocked by the utility bill and ordered all space thermostat be set up from 24 to 25 C. What is the rate of heat removal in the cooling coil before and after the change and (b) the rate of heat supplied at the reheat coils before and after change? Assume that the space sensible load remains at 140 kw?

Solution: See Fig. 5-9.

Outside air at 28 C and 30 percent relative humidity

$$h_o = 46 \text{ kJ/kg}$$

At 24 C Set-Up.

Coil entering temperature, t_m

$$t_m = [(3)(28) + (18 - 3)(24)] / 18 = 24.667 \text{ C}$$

Coil supply temperature = 13 C constant

$$\text{Cooling rate} = (18)(24.667 - 13) = 210 \text{ kw}$$

Space sensible load = 140 kw constant

Reheat supply temperature, t_s .

$$t_s = 24 - 140 / 18 = 16.222 \text{ C}$$

$$\text{Heating Rate} = (18)(16.222 - 13)$$

$$\text{Heating Rate} = 58 \text{ kw}$$

At 25 C Set-Up.

Coil entering temperature, t_m

$$t_m = [(3)(28) + (18 - 3)(25)] / 18 = 25.5 \text{ C}$$

Coil supply temperature = 13 C constant

$$\text{Cooling rate} = (18)(25.5 - 13) = 225 \text{ kw}$$

Space sensible load = 140 kw constant

Reheat supply temperature, t_s .

$$t_s = 25 - 140 / 18 = 17.222 \text{ C}$$

$$\text{Heating Rate} = (18)(17.222 - 13)$$

$$\text{Heating Rate} = 76 \text{ kw}$$

Answer:

- (a) Before = 210 kw
 After = 225 kw
 15 kw increase in cooling rate.
- (b) Before = 58 kw
 After = 76 kw
 18 kw increase in heating rate

- 0 0 0 -

- 6-1. Compute the pressure drop of 30 C air flowing with a mean velocity of 8 m/s in a circular sheet-metal duct 300 mm in diameter and 15 m long using (a) Eqs. (6-1) and (6-2) and (b) Fig. 6-2.

Solution:

Equation 6-1.

$$\Delta p = f \frac{L}{D} \frac{V^2}{2} \rho$$

Equation 6-2.

$$f = \left\{ \frac{1}{1.14 + 2 \log \frac{D}{\epsilon} - 2 \log \left[1 + \frac{9.3}{\text{Re} \left(\frac{\epsilon}{D} \right) \sqrt{f}} \right]} \right\}^2$$

$$D = 300 \text{ mm} = 0.3 \text{ m}$$

$$V = 8 \text{ m/s}$$

At 30 C, Table 6-2.

$$\mu = 18.648 \text{ mPa}\cdot\text{s} = 1.8648 \times 10^{-5} \text{ Pa}\cdot\text{s}$$

$$\rho = 1.1644 \text{ kg/m}^3$$

Table 6-1, $\epsilon = 0.00015 \text{ m}$

$$\epsilon/D = 0.00015 \text{ m} / 0.3 \text{ m} = 0.0005$$

Reynolds Number

$$\text{Re} = \frac{VD\rho}{\mu}$$

$$\text{Re} = \frac{(8)(0.3)(1.1644)}{1.8648 \times 10^{-5}} = 149,860$$

(a) Equation 6-2.

$$f = \left\{ \frac{1}{1.14 + 2 \log \left(\frac{1}{0.0005} \right) - 2 \log \left[1 + \frac{9.3}{(149860)(0.0005)\sqrt{f}} \right]} \right\}^2$$

$$f = \left\{ \frac{1}{7.74206 - 2 \log \left[1 + \frac{0.124116}{\sqrt{f}} \right]} \right\}^2$$

By trial and error; $f = 0.01935$

Equation 6-1

$$\Delta p = (0.1935) \left(\frac{15}{0.3} \right) \frac{(8)^2}{2} (1.1644)$$

$\Delta p = 36 \text{ Pa} \text{ --- Ans.}$

(b) From Fig. 6-2, $D = 0.30 \text{ m}$, $V = 8 \text{ m/s}$

Friction Loss = 2.57 Pa/m

For 15 m

$\Delta p = (15)(2.57) = 38.55 \text{ Pa} \text{ --- Ans.}$

6-2. A pressure difference of 350 Pa is available to force 20 C air through a circular sheet-metal duct 450 mm in diameter and 25 m long. Using Eq. (6-1) and Fig. 6-1, determine the velocity.

Solution:

Eq. 6-1

$$\Delta p = f \frac{L}{D} \frac{V^2}{2} \rho$$

$D = 450 \text{ mm} = 0.45 \text{ m}$

Table 6-1, $\epsilon = 0.00015$

$\epsilon/D = 0.00015 / 0.45 = 0.00033$

At 20 C , Table 6-2.

$\mu = 18.178 \text{ mPa}\cdot\text{s} = 1.8178 \times 10^{-5} \text{ Pa}\cdot\text{s}$

$\rho = 1.2041 \text{ kg/m}^3$

$$\text{Re} = \frac{VD\rho}{\mu} = \frac{(0.45)(V)(1.2041)}{1.8178 \times 10^{-5}}$$

$\text{Re} = 29,808 V$

$$\Delta p = f \frac{L}{D} \frac{V^2}{2} \rho$$

$$350 = f \left(\frac{25}{0.45} \right) \frac{V^2}{2} (1.2041)$$

$fV^2 = 10.46425$

Use Eq. 6-2.

$$f = \left\{ \frac{1}{1.14 + 2 \log \frac{D}{\epsilon} - 2 \log \left[1 + \frac{9.3}{\text{Re} \left(\frac{\epsilon}{D} \right) \sqrt{f}} \right]} \right\}^2$$

$$V = \frac{3.23485}{\sqrt{f}}$$

$$Re = (29,808) \left(\frac{3.23485}{\sqrt{f}} \right) = \frac{96,424.4}{\sqrt{f}}$$

Then:

$$f = \left\{ \frac{1}{1.14 + 2 \log \left(\frac{1}{0.00033} \right) - 2 \log \left[1 + \frac{9.3}{\left(\frac{96,424.4}{\sqrt{f}} \right) (0.00033) \sqrt{f}} \right]} \right\}^2$$

$$f = \left(\frac{1}{1.14 + 6.96297 - 0.222706} \right)^2 = 0.0161$$

$$V = \frac{3.23485}{\sqrt{0.0161}}$$

V = 25.5 m/s - - - Ans.

- 6-3 A rectangular duct has dimensions of 0.25 by 1 m. Using Fig. 6-2, determine the pressure drop per meter length when 1.2 m³/s of air flows through the duct.

Solution:

$$\begin{aligned} Q &= 1.2 \text{ m}^3/\text{s} \\ a &= 0.25 \text{ m} \\ b &= 1 \text{ m} \end{aligned}$$

Using Fig. 6-2.

Eq. 6-8.

$$D_{\text{eq},f} = 1.30 \frac{(ab)^{0.625}}{(a+b)^{0.25}}$$

$$D_{\text{eq},f} = 1.30 \frac{(0.25 \times 1.0)^{0.625}}{(0.25 + 1.0)^{0.25}}$$

$$D_{\text{eq},f} = 0.517 \text{ m}$$

Fig. 6-2: Q = 1.2 m³/s,

$$D_{\text{eq},f} = 0.517 \text{ m}$$

Then Δp = 0.65 Pa/m - - - Ans.

- 6-4. A sudden enlargement in a circular duct measures 0.2 m diameter upstream and 0.4 m diameter downstream. The upstream pressure is 150 Pa and downstream is 200 Pa. What is the flow rate of 20 C air through the fitting?

Solution:

Equation 6-11:

$$p_{\text{loss}} = \frac{V_1^2 \rho}{2} \left(1 - \frac{A_1}{A_2}\right)^2 \text{ Pa}$$

$$p_2 - p_1 = \frac{(V_1^2 - V_2^2) \rho}{2} - p_{\text{loss}}$$

Table 6-2.

At 20 C, $\rho = 1.2041 \text{ kg/m}^3$

$$A_1 V_1 = A_2 V_2$$

$$D_1 = 0.2 \text{ m}$$

$$D_2 = 0.4 \text{ m}$$

$$D_1^2 V_1 = D_2^2 V_2$$

$$(0.2)^2 V_1 = (0.4)^2 V_2$$

$$V_2 = 0.25 V_1$$

$$\frac{A_1}{A_2} = \frac{D_1^2}{D_2^2} = 0.25$$

$$p_2 - p_1 = 200 \text{ Pa} - 150 \text{ Pa} = 50 \text{ Pa}$$

$$p_2 - p_1 = \frac{(V_1^2 - V_2^2) \rho}{2} - \frac{V_1^2 \rho}{2} \left(1 - \frac{A_1}{A_2}\right)^2 \text{ Pa}$$

$$50 = \frac{[V_1^2 - (0.25V_1)^2](1.2041)}{2} - \frac{V_1^2(1.2041)}{2}(1 - 0.25)^2$$

$$V_1 = 14.88171 \text{ m/s}$$

$$Q = A_1 V_1$$

$$Q = \frac{\pi}{4} D_1^2 V_1$$

$$Q = \frac{\pi}{4} (0.2)^2 (14.88171)$$

$$Q = 0.4675 \text{ m}^3/\text{s} \text{ --- Ans.}$$

- 6-5. A duct 0.4 m high and 0.8 m wide, suspended from a ceiling in a corridor, makes a right-angle turn in horizontal plane. The inner radius is 0.2 m, and the outer radius is 1.0 m, measured from the same center. The velocity of air in the duct is 10 m/s. To how many meters of straight duct is the pressure loss in this elbow equivalent?

Solution:

Inner radius = 0.2 m

Outer radius = 1.0 m

W = 0.8 m

H = 0.4 m

Figure 6-8:

W / H = 0.8 / 0.4 = 2.0

Ratio of inner to outer radius = 0.2 / 1.0 = 0.2

Then:

$$\frac{p_{\text{loss}}}{V^2 \rho / 2} = 0.35$$

$$D_{\text{eq}} = \frac{2ab}{a+b} = \frac{2(0.8)(0.4)}{0.8+0.4} = 0.533 \text{ m}$$

Friction loss for the $D_{\text{eq}} = 1.95 \text{ Pa/m}$

Then:

$$p_{\text{loss}} = 0.35 \frac{V^2}{2} \rho$$

$$\rho = 1.2041 \text{ kg/m}^3$$

$$p_{\text{loss}} = 0.35 \frac{(10)^2}{2} (1.2041) = 21 \text{ Pa}$$

Equivalent Length = $21 \text{ Pa} / (1.95 \text{ Pa/m})$

Equivalent length = 10.8 m - - - Ans.

- 6-6. An 0.3- by 0.4-m branch duct leaves an 0.3- by 0.6-m main duct at an angle of 60° . The air temperature is 20 C. The dimensions of the main duct remain constant following the branch. The flow rate upstream is $2.7 \text{ m}^3/\text{s}$, and the pressure is 250 Pa. The branch flow rate is $1.3 \text{ m}^3/\text{s}$. What is the pressure (a) downstream in the main duct and (b) in the branch duct?

Solution:

$p_1 = 250 \text{ Pa}$, See Fig. 6-10.

$\beta = 60^\circ$

$$V_u = \frac{2.7}{(0.3)(0.6)} = 15 \text{ m/s}$$

$$V_d = \frac{2.7 - 1.3}{(0.3)(0.6)} = 7.78 \text{ m/s}$$

$$V_b = \frac{1.3}{(0.3)(0.4)} = 10.83 \text{ m/s}$$

at 20 C, $\rho = 1.2041 \text{ kg/m}^3$.

(a) Eq. 6-16.

$$p_{\text{loss}} = \frac{V_d^2 \rho}{2} (0.4) \left(1 - \frac{V_d}{V_u} \right)^2 \text{ Pa}$$

$$p_{\text{loss}} = \frac{(7.78)^2 (1.2041)}{2} (0.4) \left(1 - \frac{7.78}{15}\right)^2 \text{ Pa}$$

$$p_{\text{loss}} = 3.377 \text{ Pa}$$

Bernoulli Equation 6-10

$$p_2 = \rho \left(\frac{p_1}{\rho} + \frac{V_1^2}{2} - \frac{V_2^2}{2} - \frac{p_{\text{loss}}}{\rho} \right)$$

$$p_2 = (1.2041) \left(\frac{250}{1.2041} + \frac{15^2}{2} - \frac{7.78^2}{2} - \frac{3.377}{1.2041} \right)$$

$p_2 = 346 \text{ Pa} \dots \text{Ans.}$

(b) Fig. 6-11

$$\frac{V_b}{V_u} = \frac{10.83}{15} = 0.722$$

$$\beta = 60^\circ$$

$$\frac{p_{\text{loss}}}{\frac{V^2 \rho}{2}} = 1.583$$

$$p_{\text{loss}} = 1.583 \frac{(10.83)^2}{2} (1.2041) = 111.8 \text{ Pa}$$

$$p_2 = \rho \left(\frac{p_1}{\rho} + \frac{V_1^2}{2} - \frac{V_2^2}{2} - \frac{p_{\text{loss}}}{\rho} \right)$$

$$p_2 = (1.2041) \left(\frac{250}{1.2041} + \frac{15^2}{2} - \frac{10.83^2}{2} - \frac{111.8}{1.2041} \right)$$

$p_2 = 203 \text{ Pa} \dots \text{Ans.}$

6-7. In a branch entry, an airflow rate of $0.8 \text{ m}^3/\text{s}$ joins the main stream to give a combined flow rate of $2.4 \text{ m}^3/\text{s}$. The air temperature is 25 C . The branch enters with an angle of $\beta = 30^\circ$ (see Fig. 6-12). The area of the branch duct is 0.1 m^2 , and the area of the main duct is 0.2 m^2 both upstream and downstream. What is the reduction in pressure between points u and d in the main duct?

Solution: At 25 C , Table 6-2, $\rho = 1.18425 \text{ kg/m}^3$

Equation 6-17.

$$V_d^2 A_d \rho - V_u^2 A_d \rho - V_b^2 A_b \rho \cos \beta = (p_u - p_d) A_d$$

$$\beta = 30^\circ$$

$$V_b = \frac{Q_b}{A_b} = \frac{0.8}{0.1} = 8 \text{ m/s}$$

$$V_u = \frac{Q_u}{A_u} = \frac{2.4 - 0.8}{0.2} = 8 \text{ m/s}$$

$$V_d = \frac{Q_d}{A_d} = \frac{2.4}{0.2} = 12 \text{ m/s}$$

$$(1.18425)[(12)^2(0.2) - (8)^2(0.2) - (8)^2(0.1)\cos 30] = (p_u - p_d)(0.2)$$

$p_u - p_d = 62 \text{ Pa} \text{ ---- Ans.}$

- 6-8. A two-branch duct system of circular duct is shown in Fig. 6-20. The fittings have the following equivalent length of straight duct: upstream to branch, 4 m; elbow, 2 m. There is negligible pressure loss in the straight-through section of the branch. The designer selects 4 Pa/m as the pressure gradient in the 12- and 15-m straight sections. What diameter should be selected in the branch section to use the available pressure without dampering?

Figure 6-20. Duct system in Prob. 6-8.

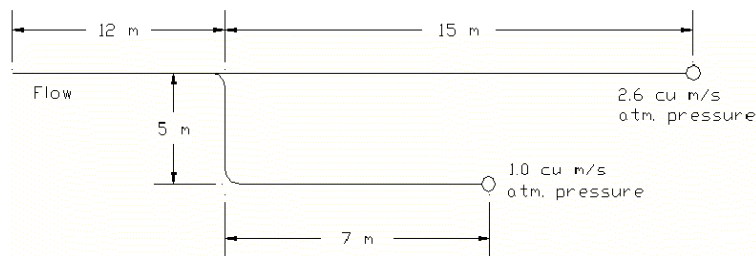

Solution:

Available pressure drop
 $= \Delta p = (12 \text{ m} + 15 \text{ m})(4 \text{ Pa/m}) = 108 \text{ Pa}$
 Pressure gradient on 5 m and 6 m section.

$$\frac{\Delta p}{L} = \frac{108 \text{ Pa}}{4 + 2 + 5 + 7 \text{ m}}$$

$$\frac{\Delta p}{L} = 6 \text{ Pa/m}$$

Figure 6-2, 6 Pa/m, 1.0 m³/s

$D = 0.31 \text{ m} \text{ ---- Ans.}$

- 6-9. A duct-system consists of a fan and a 25-m length of circular duct that delivers 0.8 m³/s of air. The installed cost is estimated to be \$115 per square meter of sheet metal, the power cost is 6 cents per kilowatt-hour, the fan efficiency is 55 percent, and the motor efficiency 85 percent. There are 10,000 h of operation during the amortization period. Assume $f = 0.02$. What is the optimum diameter of the duct?

Solution: Eq. 6-26.

$$D_{\text{opt}} = \left(\frac{5C_3HQ^3}{C_1} \right)^{1/6}$$

$$Q = 0.8 \text{ m}^3/\text{s}$$

$$L = 25 \text{ m}$$

$$H = 10,000 \text{ hrs}$$

Eq. 6-20.

$$\text{Initial Cost} = (\text{thickness})(\pi D)(L)(\text{density of metal})(\text{Installed cost / kg})$$

$$\text{Initial Cost} = (\pi D)(L)(\text{Installed cost / m}^2)$$

$$\text{Initial Cost} = C_1DL$$

$$C_1 = (\pi)(\text{Installed cost / m}^2)$$

$$C_1 = (\pi)(115) = 361.3$$

Eq. 6-22.

$$\text{Operating Cost} = C_2H\Delta pQ$$

$$C_2 = [(\$0.06 / \text{kwhr})(1 \text{ kw}/1000 \text{ W})] / [(0.55)(0.85)]$$

$$C_2 = 1.283422 \times 10^{-4}$$

Eq. 6-23

$$\Delta p = f \frac{L}{D} \frac{Q^2 \rho}{\left(\frac{\pi^2 D^4}{16} \right)^2}$$

Eq. 6-24

$$\text{Operating Cost} = C^3 LH \frac{Q^3}{D^5}$$

Substituting Eq. 6-23 to Eq. 6-22.

$$\text{Operating Cost} = C_2 H f \frac{L}{D} \frac{Q^2 \rho}{\left(\frac{\pi^2 D^4}{16} \right)^2} Q$$

$$\text{Operating Cost} = \left[\frac{C_2 f \rho}{\left(\frac{\pi^2}{16} \right)^2} \right] LH \frac{Q^3}{D^5}$$

$$C_3 = \frac{C_2 f \rho}{\left(\frac{\pi^2}{16} \right)^2}$$

$$\text{Assume } f = 0.02, \rho = 1.2041 \text{ kg/m}^3$$

$$C_3 = \frac{(1.283422 \times 10^{-4})(0.02)(1.2041)}{\left(\frac{\pi^2}{16}\right)^2}$$

$$C_3 = 8.122739 \times 10^{-6}$$

$$D_{\text{opt}} = \left(\frac{5C_3HQ^3}{C_1} \right)^{1/6}$$

$$D_{\text{opt}} = \left[\frac{5(8.122739 \times 10^{-6})(10000)(0.8)^3}{361.3} \right]^{1/6}$$

$$D_{\text{opt}} = 0.289 \text{ m} \text{ ---- Ans.}$$

- 6-10. Measurements made on a newly installed air-handling system were: 20 r/s fan speed, 2.4 m³/s airflow rate, 340 Pa fan discharge pressure, and 1.8 kw supplied to the motor. These measurements were made with an air temperature of 20 C, and the system is eventually to operate with air at a temperature of 40 C. If the fan speed remains at 20 r/s, what will be the operating values of (a) airflow be the operating values of (a) airflow rate, (b) static pressure, and (c) power?

Solution: At 20 C,

$$\omega_1 = 20 \text{ r/s}$$

$$Q_1 = 2.4 \text{ m}^3/\text{s}$$

$$SP_1 = 340 \text{ Pa}$$

$$P_1 = 1.8 \text{ kw}$$

$$\rho_1 = 1.2041 \text{ kg/m}^3$$

At 40 C

$$\omega_2 = 20 \text{ r/s}$$

$$\rho_2 = 1.1272 \text{ kg/m}^3$$

- (a) Since ω is constant also Q is constant,

$$Q_2 = 2.4 \text{ m}^3/\text{s}$$

- (b) Law 2, Q = constant

$$SP \sim \rho$$

$$SP_2 = \left(\frac{\rho_2}{\rho_1} \right) SP_1$$

$$SP_2 = \left(\frac{1.1272}{1.2041} \right) (340 \text{ Pa})$$

$$SP_2 = 318 \text{ Pa} \text{ --- Ans.}$$

- (c) Law 2, Q = constant

$$P \sim \rho$$

$$P_2 = \left(\frac{\rho_2}{\rho_1} \right) P_1$$

$$P_2 = \left(\frac{1.1272}{1.2041} \right) (1.8 \text{ kw})$$

$$P_2 = 1.685 \text{ kw} \text{ --- Ans.}$$

- 6-11. A fan-duct system is designed so that when the air temperature is 20 C, the mass flow rate is 5.2 kg/s when the fan speed is 18 r/s and the fan motor requires 4.1 kw. A new set of requirement is imposed on the system. The operating air temperature is changed to 50 C, and the fan speed is increased so that the same mass flow of air prevails. What are the revised fan speed and power requirement?

Solution:

At 20 C, Table 6-2

$$\rho_1 = 1.2041 \text{ kg/m}^3$$

$$m_1 = 5.2 \text{ kg/s}$$

$$\omega_1 = 18 \text{ r/s}$$

$$P_1 = 4.1 \text{ kw}$$

At 50 C, Table 6-2

$$\rho_2 = 1.0924 \text{ kg/s}$$

$$m_2 = 5.2 \text{ kg/s}$$

$$Q_1 = \frac{m_1}{\rho_1} = \frac{5.2}{1.2041} = 4.3186 \text{ m}^3/\text{s}$$

$$Q_2 = \frac{m_2}{\rho_2} = \frac{5.2}{1.0924} = 4.7602 \text{ m}^3/\text{s}$$

Revised fan speed, Equation 6-29

$Q \propto \omega$ or $\omega \propto 1/\rho$

$$\omega_2 = \omega_1 \frac{\rho_1}{\rho_2}$$

$$\omega_2 = (18) \frac{(1.2041)}{(1.0924)}$$

$$\omega_2 = 19.84 \text{ r/s} \text{ --- Ans.}$$

Revised power requirement, Equation 6-31.

$$P = Q(SP) + \frac{QV^2\rho}{2}$$

Equation 6-30

$$P \propto \frac{V^2\rho}{2}$$

Then

$$P \propto \frac{QV^2\rho}{2}$$

$$P \propto Q^2$$

$$P \propto \frac{1}{\rho^2}$$

$$P_2 = \frac{P_1 \rho_1^2}{\rho_2^2} = (4.1) \left(\frac{1.2041}{1.0924} \right)^2$$

$$P_2 = 4.98 \text{ kw} \text{ --- Ans.}$$

- 6-12. An airflow rate of $0.05 \text{ m}^3/\text{s}$ issues from a circular opening in a wall. The centerline velocity of the jet is to be reduced to 0.75 m/s at a point 3 m from the wall. What should be the outlet velocity u_o of this jet?

Solution: Equation 6-32.

$$u = \frac{7.41 u_o \sqrt{A_o}}{x \left[1 + 57.5 \left(\frac{r^2}{x^2} \right) \right]^2}$$

$$u = 0.75 \text{ m/s}$$

$$x = 3 \text{ m}$$

$$r = 0$$

$$u = \frac{7.41 u_o \sqrt{A_o}}{x}$$

$$A_o = \frac{Q}{u_o}$$

$$Q = 0.05 \text{ m}^3/\text{s}$$

$$u = \frac{7.41 \sqrt{u_o Q}}{x}$$

$$u = 0.75 = \frac{7.41 \sqrt{u_o (0.05)}}{3}$$

$$u_o = 1.84 \text{ m/s} \text{ --- Ans.}$$

- 6-13. Section 6-19 points out that jets entrains air as they move away from their inlet into the room. The entrainment ratio is defined as the ration of the air in motion at a given distance x from the inlet to the airflow rate at the inlet Q_x/Q_o . Use the expression for the velocity in a circular jet, Eq. (6-32), multiplied by the area of

an annular ring $2\pi r dr$ and integrate r from 0 to ∞ to find the expression for Q_x/Q_o .

Solution: Equation 6-32.

$$u = \frac{7.41 u_o \sqrt{A_o}}{x \left[1 + 57.5 \left(\frac{r^2}{x^2} \right) \right]^2}$$

$$Q_x = \int_0^{\infty} u(2\pi r dr)$$

$$Q_x = 2\pi \int_0^\infty \frac{7.41u_o \sqrt{A_o} r dr}{x \left[1 + 57.5 \left(\frac{r^2}{x^2} \right) \right]^2}$$

$$u_o \sqrt{A_o} = \frac{u_o A_o}{\sqrt{A_o}} = \frac{Q}{\sqrt{A_o}}$$

$$\frac{Q_x}{Q_o} = 2\pi \left(\frac{7.41}{x \sqrt{A_o}} \right) \int_0^\infty \frac{r dr}{\left[1 + 57.5 \left(\frac{r^2}{x^2} \right) \right]^2}$$

$$\frac{Q_x}{Q_o} = 2\pi \left(\frac{7.41}{x \sqrt{A_o}} \right) \int_0^\infty \left[1 + 57.5 \left(\frac{r^2}{x^2} \right) \right]^{-2} r dr$$

Let:

$$s = 1 + 57.5 \left(\frac{r^2}{x^2} \right)$$

$$ds = \frac{2(57.5)}{x^2} r dr$$

Then:

$$\frac{Q_x}{Q_o} = 2\pi \left(\frac{7.41x^2}{2(57.5)x \sqrt{A_o}} \right) \int_0^\infty \left[1 + 57.5 \left(\frac{r^2}{x^2} \right) \right]^{-2} \left(\frac{2(57.5)}{x^2} \right) r dr$$

$$\frac{Q_x}{Q_o} = \frac{0.405x}{-\sqrt{A_o}} \left[\left[1 + 57.5 \left(\frac{r^2}{x^2} \right) \right]^{-1} \right]_0^\infty$$

$$\frac{Q_x}{Q_o} = \frac{0.405x}{-\sqrt{A_o}} (0 - 1)$$

$$\frac{Q_x}{Q_o} = \frac{0.405x}{\sqrt{A_o}} \text{----- Ans.}$$

- 6-14. From the equation for velocities in a plane jet, determine the total included angle between the planes where the velocities are one-half the centerline velocities at that x position.

Solution: Equation 6-33.

$$u = \frac{2.40u_o \sqrt{b}}{\sqrt{x}} \left[1 - \tanh^2 \left(7.67 \frac{y}{x} \right) \right]$$

Centerline Velocity
y = 0

$$u_c = \frac{2.40u_o \sqrt{b}}{\sqrt{x}}$$

At 1/2 of centerline velocity at x position.

$$\frac{1}{2}u_c = \frac{2.40u_o\sqrt{b}}{\sqrt{x}} \left[1 - \tanh^2\left(7.67\frac{y}{x}\right) \right]$$

or

$$\frac{1}{2} = 1 - \tanh^2\left(7.67\frac{y}{x}\right)$$

$$\frac{y}{x} = 0.114912$$

Total included angle, θ

$$\theta = 2\text{Arctan}\left(\frac{y}{x}\right) = 2\text{Arctan}(0.114912)$$

$$\theta = 13.11^\circ \text{ --- Ans.}$$

- 0 0 0 -

- 7-1. A convector whose performance characteristics are shown in Fig. 7-4 is supplied with a flow rate of 0.04 kg/s of water at 90 C. The length of the convector is 4 m, and the room-air temperature is 18 C. What is the rate of heat transfer from the convector to the room air?

Solution:

See Fig. 7-4

$$m = 0.04 \text{ kg/s}$$

$$t_1 = 90 \text{ C}$$

$$L = 4 \text{ m}$$

$$t_r = 18 \text{ C}$$

$$t_2 = t_1 - \frac{q}{mc_p}$$

$$c_p = 4.19 \text{ kJ/kg.K}$$

$$t_2 = 90 - \frac{q}{(0.04)(4190)}$$

$$t_2 = 90 - 0.0059666q$$

Mean Water Temp.

$$t_m = \frac{1}{2}(t_1 + t_2)$$

$$t_m = \frac{1}{2}(90 + 90 - 0.0059666q)$$

$$t_m = 90 - 0.0029833q$$

Equation for Fig. 7-4.

$$\frac{q}{L} = 16t_m - 560 \text{ W/m}$$

$$q = (4)(16t_m - 560)$$

$$q = 64t_m - 2240$$

Substituting:

$$t_m = 90 - 0.0029833(64t_m - 2240)$$

$$t_m = 81.182 \text{ C}$$

$$q = 64t_m - 2,240 \text{ Watts}$$

$$q = 64(81.182) - 2,240 \text{ Watts}$$

$$q = 2,956 \text{ Watts}$$

$$q = 2.956 \text{ kW ---- Ans.}$$

- 7-2. Compute the pressure drop in pascals per meter length when a flowrate of 8 L/s of 60 C water flows through a Schedule 40 steel pipe of nominal diameter 75 mm (a) using Eq. (7-1) and (b) using Figs. 7-6 and 7-7.

Solution:

(a) Eq. 7-1.

$$\Delta p = f \frac{L}{D} \frac{V^2}{2} \rho$$

From Table 7-3 at 60 C.

$$\rho = 983.19 \text{ kg/m}^3$$

$$\mu = 0.476 \text{ mPa.s} = 0.000476 \text{ Pa.s}$$

75-mm Schedule 40 Steel Pipe, Table 7-1, ID = 77.92 mm

$$V = \frac{0.008 \text{ m}^3/\text{s}}{\pi(0.07792 \text{ m})^2 / 4} = 1.678 \text{ m/s}$$

Table 6-1, $\epsilon = 0.000046$ commercial steel.

$$\frac{\epsilon}{D} = \frac{0.000046}{0.07792} = 0.00059$$

$$Re = \frac{DV\rho}{\mu} = \frac{(1.678)(0.07792)(983.19)}{0.000476}$$

$$Re = 270,067$$

From the Moody Chart, Fig. 6-1.

$$Re = 270,067,$$

$$\frac{\epsilon}{D} = 0.00059$$

$$f = 0.019$$

$$\Delta p = f \frac{L}{D} \frac{V^2}{2} \rho$$

$$\frac{\Delta p}{L} = (0.019) \left(\frac{1}{0.07792} \right) \frac{(1.678)^2}{2} (983.19)$$

$$\Delta p/L = 338 \text{ Pa/m} \text{ ---- Ans.}$$

- 7-3. In the piping system shown schematically in Fig. 7-14 the common pipe has a nominal 75 mm diameter, the lower branch 35 mm, and the upper branch 50 mm. The pressure of water at the entrance is 50 kPa above atmospheric pressure, and both branches discharged to atmospheric pressure. The water temperature is 20 C. What is the water flow rate in liters per second in each branch?

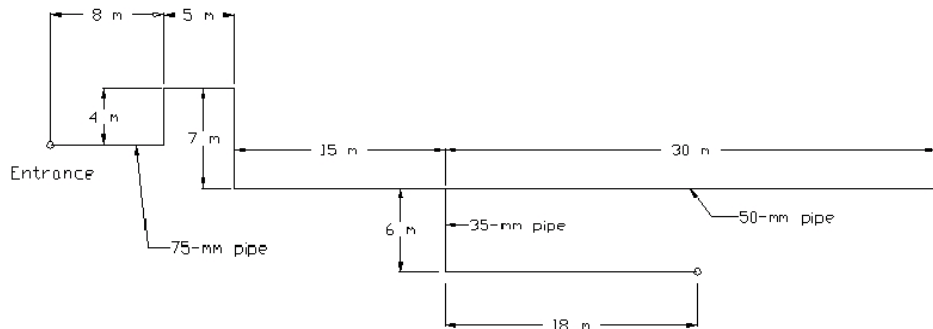

Figure 7-14. Piping system in Prob. 7-3.

Solution:

$$\Delta p = 50 \text{ kPa} - 0 - 50 \text{ kPa} = 5000 \text{ Pa}$$

Use Fig. 7-6, water temperature of 20 C

Table 7-4.

For 75-mm pipe

$$\text{Elbow} = 4 \times 3 \text{ m} = 12 \text{ m}$$

$$\text{Straight Pipe} = 8 \text{ m} + 4 \text{ m} + 5 \text{ m} + 7 \text{ m} + 15 \text{ m} = 39 \text{ m}$$

$$L_1 = 12 \text{ m} + 39 \text{ m} = 51 \text{ m}$$

For 50-mm pipe

Straight Branch = 0.9 m

Straight Pipe = 30 m

$L_2 = 0.9 \text{ m} + 30 \text{ m} = 30.9 \text{ m}$

For 35-mm pipe

Side Branch = 4.6 m

Straight Pipe = 6 m + 18 m = 24 m

Elbow = 1 x 1.2 m = 1.2 m

$L_3 = 4.6 \text{ m} + 24 \text{ m} + 1.2 \text{ m} = 29.8 \text{ m}$

$$Q_1 = Q_2 + Q_3$$

$$\left(\frac{\Delta p_1}{L_1}\right)L_1 + \left(\frac{\Delta p_2}{L_2}\right)L_2 = \Delta p$$

$$\left(\frac{\Delta p_1}{L_1}\right)L_1 + \left(\frac{\Delta p_3}{L_3}\right)L_3 = \Delta p$$

$$\left(\frac{\Delta p_2}{L_2}\right)L_2 = \left(\frac{\Delta p_3}{L_3}\right)L_3$$

$$\left(\frac{\Delta p_2}{L_2}\right)(30.9) = \left(\frac{\Delta p_3}{L_3}\right)(29.8)$$

$$\left(\frac{\Delta p_3}{L_3}\right) = 1.036913 \left(\frac{\Delta p_2}{L_2}\right)$$

Assume $f = 0.02$

$\rho = 998.21 \text{ kg/m}^3$.

For 75-mm pipe, ID = 77.92 mm = 0.07792 m

For 50-mm pipe, ID = 52.51 mm = 0.05251 m

For 35-mm pipe, ID = 35.04 mm = 0.03504 m

$$\frac{\Delta p}{L_1} = f \left(\frac{1}{D}\right) \frac{V^2}{2} \rho$$

$$Q = \frac{1}{4} \pi D^2 V$$

$$V = \frac{4Q}{\pi D^2}$$

$$\frac{\Delta p_1}{L_1} = f \left(\frac{1}{D}\right) \left(\frac{8Q_1^2}{\pi^2 D_1^4}\right) \rho$$

$$\frac{\Delta p_1}{L_1} = f \left(\frac{8Q_1^2}{\pi^2 D_1^5}\right) \rho$$

$$\frac{\Delta p_1}{L_1} = 0.02 \left(\frac{8Q_1^2}{\pi^2 (0.07792)^5}\right) (998.21) = 5,633,748 Q_1^2$$

$$\frac{\Delta p_2}{L_2} = 0.02 \left(\frac{8Q_2^2}{\pi^2 (0.05251)^5}\right) (998.21) = 40,535,176 Q_2^2$$

$$\frac{\Delta p_3}{L_3} = 0.02 \left(\frac{8Q_2^2}{\pi^2 (0.03504)^5} \right) (998.21) = 306,352,668Q_3^2$$

(1)

$$\left(\frac{\Delta p_1}{L_1} \right) (51) + \left(\frac{\Delta p_2}{L_2} \right) (30.9) = 50,000$$

$$(5,633,748Q_1^2) (51) + (40,535,176Q_2^2) (30.9) = 50,000$$

$$(5,633,748Q_1^2) (51) + (40,535,176Q_2^2) (30.9) = 50,000$$

$$287,321,148Q_1^2 + 1,253,093,138Q_2^2 = 50,000$$

(2)

$$\left(\frac{\Delta p_3}{L_3} \right) = 1.036913 \left(\frac{\Delta p_2}{L_2} \right)$$

$$306,352,668Q_3^2 = 1.036913(40,535,176Q_2^2)$$

$$Q_2 = 2.7Q_3$$

$$Q_1 = Q_2 + Q_3$$

$$Q_1 = 2.7Q_3 + Q_3$$

$$Q_1 = 3.7Q_3$$

Then.

$$287,321,148Q_1^2 + 1,253,093,138Q_2^2 = 50,000$$

$$287,321,148(3.7Q_3)^2 + 1,253,093,138(2.7Q_3)^2 = 50,000$$

$$Q_3 = 0.00196 \text{ m}^3/\text{s}$$

Q₃ = 1.96 L/s --- Ans.

$$Q_2 = 2.7Q_3$$

Q₂ = 5.29 L/s ---- Ans.

$$Q_1 = 3.8Q_3$$

Q₁ = 7.25 L/s ---- Ans.

- 7-4. A centrifugal pump with the characteristics shown in Fig. 7-9 serves a piping network and delivers 10 L/s. An identical pump is placed in parallel with the original one to increase the flow rate. What is (a) the new flow rate in liters per second and (b) the total power required by the two pumps?

Solution:

Use Fig. 7-9.
 At 10 L/s. Pressure Rise, $\Delta p = 130 \text{ kPa}$
 Efficiency = $\eta = 62 \%$
 $P = (0.10)(130) / (0.62) = 2.097 \text{ kw}$

For the pipe network.
 $\Delta p \propto Q^2$

$$Q_1 = 10 \text{ L/s}$$

$$\Delta p_1 = 130 \text{ kPa}$$

Use trial and error to find Q_2 and Δp_2 that will lie along the pump curve in Fig. 7-9.

Trial 1, $Q_2 = 15 \text{ L/s}$

$$\Delta p_2 = \Delta p_1 \left(\frac{Q_2}{Q_1} \right)^2$$

$$\Delta p_2 = (130) \left(\frac{15}{10} \right)^2 = 292.5 \text{ kPa}$$

Each pump = $Q = 7.5 \text{ L/s}$

From Fig. 7-9. $\Delta p = 210 \text{ kPa} < 292.5 \text{ kPa}$

Trial 2, $Q_2 = 13.3 \text{ L/s}$

$$\Delta p_2 = \Delta p_1 \left(\frac{Q_2}{Q_1} \right)^2$$

$$\Delta p_2 = (130) \left(\frac{13.3}{10} \right)^2 = 230 \text{ kPa}$$

Each pump = $Q = 6.65 \text{ L/s}$

From Fig. 7-9. $\Delta p = 230 \text{ kPa} \sim 230 \text{ kPa}$

Efficiency = 80 %

Then $Q_2 = 13.3 \text{ L/s total} \text{ --- Ans.}$

$$\text{Power} = 2(0.00665)(230) / 0.80$$

Power = 3.82 kW ---- Ans.

- 7-5. An expansion tank is to be sized so that the change in air volume between the cold-water conditions (25 C) and the operating water temperature (85 C) is to be one fourth the tank volume. If $p_i = 101 \text{ kPa abs}$ and $p_c = 180 \text{ kPa abs}$, what will p_h be?

Solution:

Eq. 7-7.

$$\frac{1}{\frac{p_i}{p_b} - \frac{p_i}{p_h}} = \frac{V_t}{V_B - V_C}$$

$$V_B - V_C = 0.25V_t$$

$$\frac{1}{\frac{p_i}{p_b} - \frac{p_i}{p_h}} = \frac{V_t}{0.25V_t}$$

$$\frac{p_i}{p_c} - \frac{p_i}{p_h} = 0.25$$

$$\frac{101}{180} - \frac{101}{p_h} = 0.25$$

$p_h = 325 \text{ kPa abs.} \text{ --- Ans.}$

- 0 0 0 -

- 8-1. A cooling and dehumidifying coil is supplied with 2.4 m³/s of air at 29 C dry-bulb and 24 C wet-bulb temperatures, and its cooling capacity is 52 kW. The face velocity is 2.5 m/s. and the coil is of the direct-expansion type provided with refrigerant evaporating at 7 C. The coil has an air-side heat-transfer area of 15 m² per square meter of face area per row of tubes. The ratio of the air-side to refrigerant-side area is 14. The values of h_r and h_c are 2050 and 65 W/m².K, respectively. Calculate (a) the face area, (b) the enthalpy of outlet air, (c) the wetted-surface temperatures at the air inlet, air outlet, and at the point where the enthalpy of air is midway between its entering and leaving conditions, (d) the total surface area, (e) the number of rows of tubes, and (f) the outlet dry-bulb temperature of the air.

Solution:

At 29 C dry-bulb and 24 C wet-bulb

$$h_{a,1} = 72.5 \text{ kJ/kg}$$

$$g_{a,1} = 0.88 \text{ m}^3/\text{kg}$$

(a) Face Area = (2.4 m³/s) / (2.5 m/s)
Face Area = 0.96 m²

(b) Enthalpy of outlet air, h_{a,2}
m = (2.4 m³/s) / (0.88 m³/kg) = 2.7273 kg/s
$$h_{a,2} = h_{a,1} - \frac{q_t}{m}$$
$$h_{a,2} = 72.5 \text{ kJ/kg} - \frac{52 \text{ kW}}{2.7273 \text{ kg/s}}$$
$$h_{a,2} = 53.4 \text{ kJ/kg}$$

(c) Wetted Surface Temperature
Eq. 8-1.

$$dq = \frac{h_c dA}{c_{pm}} (h_a - h_i)$$

Eq. 8-2.

$$dq = h_r dA_i (t_i - t_r)$$

Eq. 8-3.

$$R = \frac{t_i - t_r}{h_a - h_i} = \frac{h_c A}{c_{pm} h_r A_i}$$

$$t_r = 7 \text{ C}$$

$$A/A_i = 14$$

$$h_r = 2050 \text{ W/m}^2.\text{K}$$

$$h_c = 65 \text{ W/m}^2.\text{K}$$

$$c_{pm} = 1.02 \text{ kJ/kg.K}$$

$$R = \frac{t_i - t_r}{h_a - h_i} = \frac{(65)(14)}{(1.02)(2050)} = 0.4352$$

h_a and h_i in kJ/kg

Eq. 8-4.

$$h_i = 9.3625 + 1.7861t_i + 0.01135t_i^2 + 0.00098855t_i^3$$

Eq. 8-5.

$$\frac{t_i - t_r}{R} - h_a + 9.3625 + 1.7861t_i + 0.01135t_i^2 + 0.00098855t_i^3 = 0$$

At the air inlet, $h_{a,1} = 72.5$ kJ/kg

$$\frac{t_i}{0.4352} - \frac{7}{0.4352} - 72.5 + 9.3625 + 1.7861t_i + 0.01135t_i^2 + 0.00098855t_i^3 = 0$$

By trial and error: $t_i = 17.31$ C and enthalpy $h_i = 48.8$ kJ/kg at air inlet.

At the air outlet, $h_{a,3} = 53.4$ kJ/kg

$$\frac{t_i}{0.4352} - \frac{7}{0.4352} - 53.4 + 9.3625 + 1.7861t_i + 0.01135t_i^2 + 0.00098855t_i^3 = 0$$

By trial and error: $t_i = 13.6$ C and enthalpy $h_i = 38.23$ kJ/kg at air outlet.

At the midway enthalpy, $h_{a,2} = (1/2)(72.5 \text{ kJ/kg} + 53.4 \text{ kJ/kg}) = 62.95$ kJ/kg

$$\frac{t_i}{0.4352} - \frac{7}{0.4352} - 62.95 + 9.3625 + 1.7861t_i + 0.01135t_i^2 + 0.00098855t_i^3 = 0$$

By trial and error: $t_i = 15.5$ C and enthalpy $h_i = 43.46$ kJ/kg at midway enthalpy.

Answer - - - 17.31 C, 15.5 C, and 13.6 C.

(d) Total surface area.

Between 1 and 2.

$$q_{1-2} = m(h_1 - h_2) = \frac{h_c A_{1-2}}{c_{pm}} (\text{mean - enthalpy difference})$$

$$c_{pm} = 1020 \text{ J/kg.K}$$

$$(2.7273)(72.5 - 62.95) = \frac{(65)A_{1-2}}{1020} \left(\left(\frac{72.5 + 62.95}{2} \right) - \left(\frac{48.8 + 43.46}{2} \right) \right)$$

$$A_{1-2} = 18.93 \text{ m}^2$$

Between 2 and 3.

$$q_{2-3} = m(h_2 - h_3) = \frac{h_c A_{2-3}}{c_{pm}} (\text{mean - enthalpy difference})$$

$$c_{pm} = 1020 \text{ J/kg.K}$$

$$(2.7273)(62.95 - 53.4) = \frac{(65)A_{2-3}}{1020} \left(\left(\frac{62.95 + 53.4}{2} \right) - \left(\frac{43.46 + 38.23}{2} \right) \right)$$

$$A_{2-3} = 23.59 \text{ m}^2$$

$$\text{Surface Area of Coil} = 18.93 \text{ m}^2 + 23.59 \text{ m}^2$$

Surface Area of Coil = **42.52 m² - - - Ans.**

(e) The number of rows of tubes.

$$\text{No. of rows} = (42.52 \text{ m}^2) / [(15 \text{ m}^2/\text{m}^2)(0.96 \text{ m}^2)]$$

No. of rows = 3 rows - - - Ans.

(f) Outlet dry-bulb temperature.

$$Q_s = (2.7273 \text{ kg/s})(c_{pm})(t_1 - t_2)$$

$$c_{pm} = 1020 \text{ J/kg.K}$$

$$Q_s = A_{1-2} h_c \left(\frac{t_1 + t_2}{2} - \frac{t_{i,1} + t_{i,2}}{2} \right)$$

Between 1 and 2.

$$(2.7273)(1020)(29 - t_2) = (18.93)(65) \left(\frac{29 + t_2}{2} - \frac{17.31 + 15.5}{2} \right)$$

$$t_2 = 23.75 \text{ C}$$

Between 2 and 3.

$$(2.7273)(1020)(23.75 - t_3) = (23.59)(65) \left(\frac{23.75 + t_3}{2} - \frac{15.5 + 13.6}{2} \right)$$

$$t_3 = 19.8 \text{ C - - - Ans.}$$

8-2. For the area A1-2 in Example 8-2 using the entering conditions of the air and the wetted-surface temperatures at points 1 and 2, (a) calculate the humidity ratio of the air at point 2 using Eq. (8-6), and (b) check the answer with the humidity ratio determined from the dry-bulb temperature and enthalpy at point 2 calculated in Example 8-1.

Solution: (a) See Example 8-2.

Entering Conditions at Point 1

$$h_a = 60.6 \text{ kJ/kg}$$

$$t_r = 12.0 \text{ F}$$

$$t_i = 16.28 \text{ F}$$

$$h_i = 45.72 \text{ kJ/kg}$$

Wetted-Surface at point 2

$$h_a = 48.66 \text{ kJ/kg}$$

$$t_r = 9.5 \text{ F}$$

$$t_i = 12.97 \text{ F}$$

$$h_i = 36.59 \text{ kJ/kg}$$

Eq. 8-6.

$$G(W_1 - W_2) = \frac{h_c A_{1-2}}{c_{pm}} \left(\frac{W_1 + W_2}{2} - \frac{W_{i,1} + W_{i,2}}{2} \right)$$

$$G = 2.5 \text{ kg/s}$$

$$A_{1-2} = 41.1 \text{ m}^2$$

$$c_{pm} = 1.02 \text{ kJ/kg.K} = 1020 \text{ W/kg.K}$$

$$h_c = 55 \text{ W/m}^2.\text{K}$$

For W_1 , psychrometric chart

At 30 C dry-bulb and 21 C wet-bulb temperature.

$$W_1 = 0.012 \text{ kg/kg}$$

Table A-2.

$$t_{i,1} = 16.28 \text{ C,}$$

$$W_{i,1} = 0.01163 \text{ kg/kg}$$

$$t_{i,2} = 12.97 \text{ C}$$

$$W_{i,2} = 0.00935 \text{ kg/kg}$$

Solve for W_2 by substituting to Eq. 8-6.

$$(2.5)(0.012 - W_2) = \frac{(55)(41.1)}{1020} \left(\frac{0.012 + W_2}{2} - \frac{0.01163 + 0.00935}{2} \right)$$

$$W_2 = 0.0111 \text{ kg/kg} \text{ --- Ans.}$$

(b) Checking W_2 :

At point 2., $h_{a,2} = 48.66 \text{ F}$, $t_2 = 20.56 \text{ C}$

From psychrometric chart, Figure 3-1

$$W_2 = 0.011 \text{ kg/kg} \text{ --- Ans.}$$

- 8-3. A direct-expansion coil cools 0.53 kg/s of air from an entering condition of 32 C dry-bulb and 20 C wet-bulb temperature. The refrigerant temperature is 9 C, $h_r = 2 \text{ kW/m}^2.\text{K}$, $h_c = 54 \text{ W/m}^2.\text{K}$, and the ratio of air-side to refrigerant-side areas is 15. Calculate (a) the dry-bulb temperature of the air at which condensation begins and (b) the surface area in square meters of the portion of the coil that is dry.

Solution:

$$m = 0.53 \text{ kg/s}$$

At 32 C dry-bulb and 20 C wet-bulb temperatures

$$h_{a,1} = 57 \text{ kJ/kg}$$

(a) Dew-point of entering air = $t_{i,2} = 13.8 \text{ C}$

Equation 8-11.

$$(t_2 - t_{i,2}) h_c dA = (t_{i,2} - t_r) \frac{h_r dAA_i}{A}$$

Then:

$$(t_2 - t_{i,2})h_c = (t_{i,2} - t_r) \frac{h_r A_i}{A}$$

$$h_c = 54 \text{ W/m}^2\text{.K}$$

$$h_r = 2000 \text{ W/m}^2\text{.K}$$

$$t_r = 9 \text{ C}$$

$$A/A_i = 15$$

$$(t_2 - 13.8)(54) = \frac{(13.8 - 9)(2000)}{15}$$

$$t_2 = 25.7 \text{ C} \text{ ---- Ans.}$$

(b)

$$Gc_{pm}(t_1 - t_2) = \frac{1}{\frac{1}{h_c} + \frac{A}{A_i h_r}} A_{1-2} \left(\frac{t_1 + t_2}{2} - t_r \right)$$

$$c_{pm} = 1020 \text{ J/kg.K}$$

$$G = 0.53 \text{ kg/s}$$

$$(0.53)(1020)(32 - 25.7) = \frac{1}{\frac{1}{54} + \frac{15}{2000}} A_{1-2} \left(\frac{35 + 25.7}{2} - 9 \right)$$

$$A_{1-2} = 4.47 \text{ m}^2 \text{ --- Ans.}$$

- 8-4. For a coil whose performance and conditions of entering air are shown in Table 8-1, when the face velocity is 2 m/s and the refrigerant temperature is 4.4 C, calculate (a) the ratio of moisture removal to reduction in dry-bulb temperature in the first two rows of tubes in the direction of air flow in the last two rows and (b) the average cooling capacity of the first two and the last two rows in kilowatts per square meter of face area.

Solution: Use Table 8-1.

Face velocity = 2 m/s

Refrigerant Temperature = 4.4 C.

- (a) First 2-rows:
 At 30 C dry-bulb, 21.7 C wet-bulb temperature
 $h_1 = 63 \text{ kJ/kg}$
 $W_1 = 0.013 \text{ kg/kg}$
 $\gamma_1 = 0.08735 \text{ m}^3/\text{kg}$
 Final DBT = 18.2 C
 Final WBT = 17.1 C
 $h_2 = 48.5 \text{ kJ/kg}$
 $W_2 = 0.0119 \text{ kg/kg}$

$$\begin{aligned} \text{Ratio for the first two rows} &= (W_1 - W_2) / (t_1 - t_2) \\ &= (0.013 - 0.0119) / (30 - 18.2) \\ &= 0.0000932 \text{ kg/kg.K} \text{ ---- Ans.} \end{aligned}$$

For the last two rows.

Rows of tube = 4 in Table 8-1.

Final DBT = 14.3 C

Final WBT = 13.8 C

$$h_3 = 38.5 \text{ kJ/kg}$$

$$W_3 = 0.0095 \text{ kg/kg}$$

$$\text{Ratio for the last two rows} = (W_2 - W_3) / (t_2 - t_3)$$

$$= (0.0119 - 0.0095) / (18.2 - 13.8)$$

$$= \mathbf{0.00055 \text{ kg/kg.K} \text{ --- Ans.}}$$

(b) First two rows.
kW per sq m of face area

$$= [(2 \text{ m/s}) / (0.8735 \text{ m}^3/\text{kg})] (h_1 - h_2)$$

$$= (2 / 0.8735)(63 - 48.5)$$

$$= \mathbf{33.2 \text{ kw} \text{ --- Ans.}}$$

For the last two rows.
kW per sq m of face area

$$= [(2 \text{ m/s}) / (0.8735 \text{ m}^3/\text{kg})] (h_2 - h_3)$$

$$= (2 / 0.8735)(48.5 - 38.5)$$

$$= \mathbf{22.9 \text{ kw} \text{ --- Ans.}}$$

8-5. An airflow rate of 0.4 kg/s enters a cooling and dehumidifying coil, which for purpose of analysis is divided into two equal areas, A_{1-2} and A_{2-3} . The temperatures of the wetted coil surfaces are $t_{i,1} = 12.8 \text{ C}$, $t_{i,2} = 10.8 \text{ C}$, and $t_{i,3} = 9.2 \text{ C}$. The enthalpy of entering air $h_{a,1} = 81.0$ and $h_{a,2} = 64.5 \text{ kJ/kg}$. Determine $h_{a,3}$.

Soution:

$$G = 0.4 \text{ kg/s}$$

Then equation:

$$\frac{q_{1-2}}{\left[\left(\frac{h_{a,1} + h_{a,2}}{2} \right) - \left(\frac{h_{i,1} + h_{i,2}}{2} \right) \right]} = \frac{q_{1-2}}{\left[\left(\frac{h_{a,2} + h_{a,3}}{2} \right) - \left(\frac{h_{i,2} + h_{i,3}}{2} \right) \right]}$$

Eq. 8-4.

$$h_i = 9.3625 + 1.786t_i + 0.01135t_i^2 + 0.00098855t_i^3$$

$$\text{At } t_{i,1} = 12.8 \text{ C}$$

$$h_{i,1} = 36.16 \text{ kJ/kg}$$

$$\text{At } t_{i,2} = 10.8 \text{ C}$$

$$h_{i,2} = 31.22 \text{ kJ/kg}$$

$$\text{At } t_{i,3} = 9.2 \text{ C}$$

$$h_{i,3} = 27.52 \text{ kJ/kg}$$

Then:

$$\frac{h_{a,1} - h_{a,2}}{\left[\left(\frac{h_{a,1} + h_{a,2}}{2} \right) - \left(\frac{h_{i,1} + h_{i,2}}{2} \right) \right]} = \frac{h_{a,2} - h_{a,3}}{\left[\left(\frac{h_{a,2} + h_{a,3}}{2} \right) - \left(\frac{h_{i,2} + h_{i,3}}{2} \right) \right]}$$

$$\frac{81 - 64.5}{\left[\left(\frac{81 + 64.5}{2} \right) - \left(\frac{36.16 + 31.22}{2} \right) \right]} = \frac{64.5 - h_{a,3}}{\left[\left(\frac{64.5 + h_{a,3}}{2} \right) - \left(\frac{31.22 + 27.52}{2} \right) \right]}$$

$$0.422427(0.5h_{a,3} + 2.88) = 64.5 - h_{a,3}$$

$$1.211214h_{a,3} = 63.28341$$

$$h_{a,3} = \mathbf{52.25 \text{ kJ/kg} \text{ --- Ans.}}$$

9-1. A space thermostat regulates the damper in the cool-air supply duct and thus provides a variable air flow rate. Specify whether the damper should be normally open or normally closed and whether the thermostat is direct- or reverse-acting.

Answer: Use normally closed damper and reverse-acting thermostat since as the space temperature increases the volume rate of air will increase the pressure will reduce.

9-2. On the outdoor-air control system of Example 9-4, add the necessary features to close the outdoor-air damper to the minimum position when the outdoor temperature rises above 24 C.

Answer: Add a diverting relay. Pressure will divert to 68 kPa (20 %) minimum position when the outdoor temperature rises above 24 C.

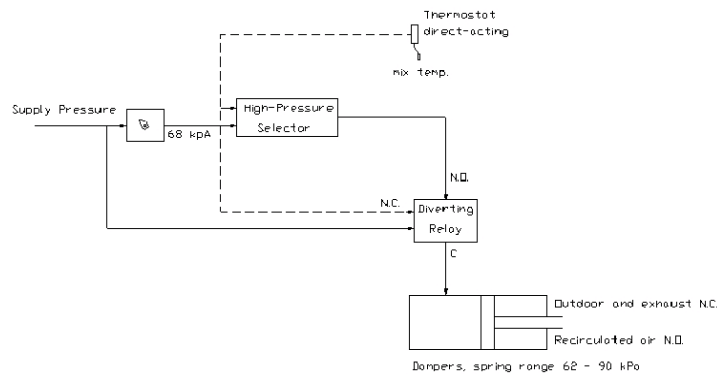

9-3. The temperature transmitter in an air-temperature controller has a range of 8 to 30 C through which range the pressure output change from 20 to 100 kPa. If the gain of the receiver-controller is set at 2 to 1 and the spring range of the cooling-water valve the controller regulates is 28 to 55 kPa, what is the throttling range of this control?

Solution:

$$\text{Output of temperature transmitter} = (100 - 20 \text{ kPa}) / (30 - 8 \text{ C}) = 3.6364 \text{ kPa/K}$$

$$\text{Throttling Range} = (55 \text{ kPa} - 28 \text{ kPa}) / [(2)(3.6364 \text{ kPa/K})]$$

Throttling Range = 3.7 K . . . Ans.

9-4 The air supply for a laboratory (Fig. 9-29) consists of a preheat coil, humidifier, cooling coil, and heating coil. The space is to be maintained at 24 C, 50 percent relative humidity the year round, while the outdoor supply air may vary in relative humidity between 10 and 60 percent and the temperature from -10 to 35 C. The spring ranges available for the valves are 28 to 55 and 62 to 90 kPa. Draw the control diagram, adding any additional components needed, specify the action of the thermostat(s) and humidistat, the spring ranges of the valves, and whether they are normally open or normally closed.

Answer:

Spring range = 28 to 55 kPa
= 62 to 90 kPa

(a) Limitations:

Use preheat coil when space temperature is less than 24 C.
 Use humidifier when space relative humidity is less than 50 percent.
 Use cooling coil when space temperature is greater than 24 C.
 Use reheat coil when space relative humidity is greater than 5- percent.

(b) Valves.

Preheat coil and reheat coil has normally open valves.
 Humidifier has normally closed valves.
 Cooling coils has normally closed valves.

(c) Action

Action of thermostat is to control temperature by preheat coil and cooling coil.
 Action of humidistat is to control temperature by humidifier and reheat coil.

(d) Control diagram

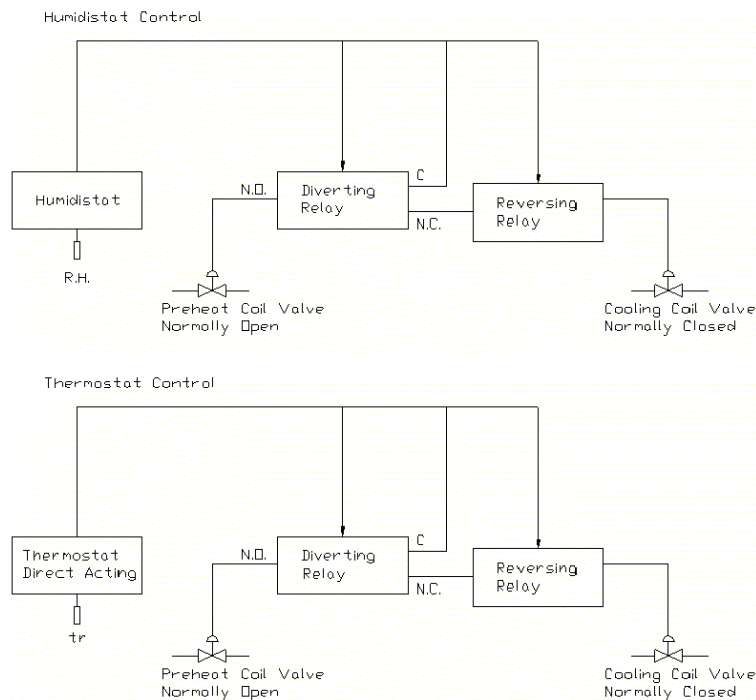

9-5. A face-and-bypass damper assembly at a cooling coil is sometimes used in humid climates to achieve greater dehumidification for a given amount of sensible cooling, instead of permitting all the air to pass over the cooling coil. Given the hardware in Fig. 9-30, arrange the control system to regulate the temperature at 24 C and the relative humidity at 50 percent. If both the temperature and humidity cannot be maintained simultaneously, the temperature control should override the humidity control. The spring ranges available for the valve and damper are 28 to 55 and 48 to 76 kPa. Draw the control diagram and specify the action of the thermostat and humidistat, whether the valve is normally open or normally closed, and which damper is normally closed.

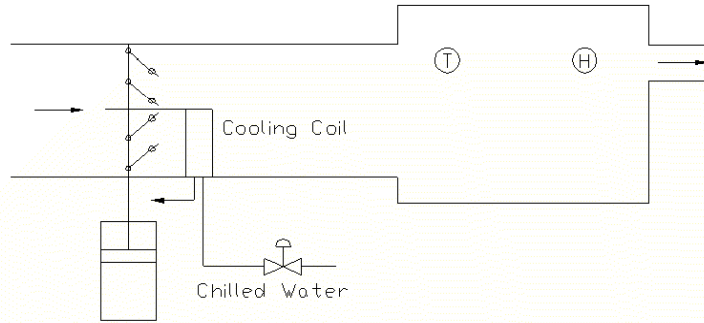

Fig. 9-30. Face and bypass damper control.

Answer:

By-pass damper is normally open,
 Face damper is normally open.
 Chilled water valve is normally open.
 Damper operator is normally open

Chilled water valve opens when space temperature is greater than 24 C.
 Chilled water valve closes when space temperature is less than 24 C.

Damper operator is closing when the relative humidity is greater than 50 percent.
 Damper operator is opening when the relative humidity is less than 50 percent.
 Damper operator is opening the by-pass damper while closing the face damper from N.O. position.

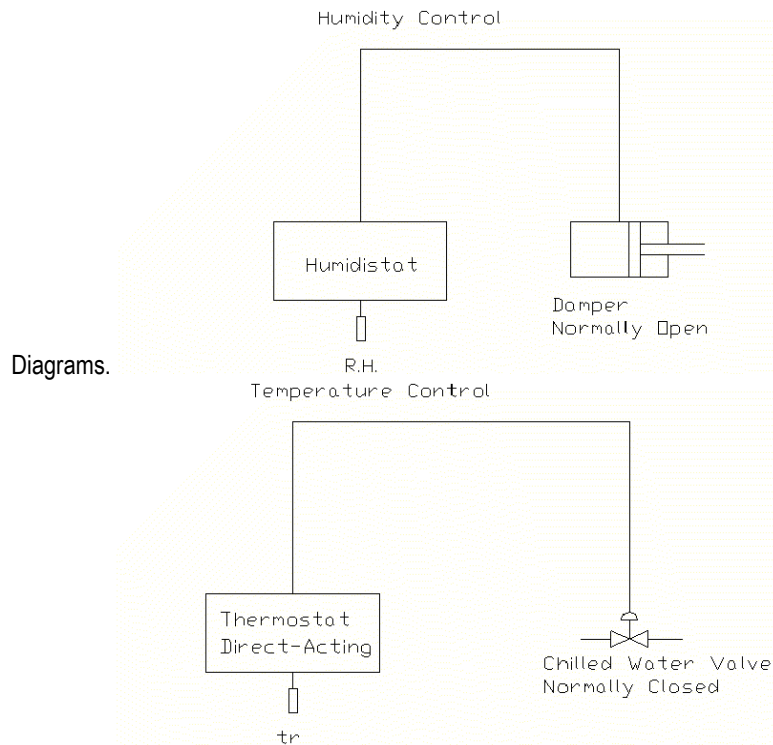

When temperature control override the humidity control.

1. Chilled water valve closing when temperature is less than 24 C and opening when temperature is greater than 24 C.

2. Damper is closing when the temperature is less than 24 C and opening when temperature is greater than 24 C.

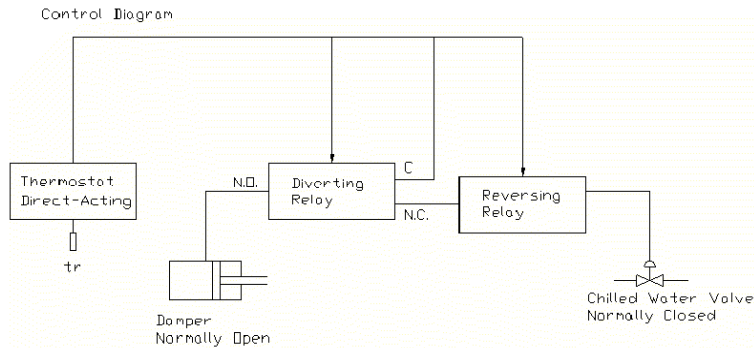

- 9-6. Section 9-18 described the flow characteristics of a coil regulated by a valve with linear characteristics. The equation of the flow-stem position for another type of valve mentioned in Sec. 9-18, the equal-percentage valve, is

$$\frac{Q}{C_v \sqrt{\Delta p}} = A^x \quad \text{where } x = \frac{\text{percent of stem stroke}}{100} - 1$$

If such a valve with an A value of 20 and a Cv of 1.2 is applied to controlling the coil in Fig. 9-25 with $D_{\text{coil}} = 2.5Q^2$ and the total pressure drop across the valve and coil of 80 kPa, what is the flowrate when the valve stem stroke is at the halfway position? (Compare with a linear-characteristic valve in Fig. 9-27.)

Solution:

$$\Delta p = 80 \text{ kPa} - 2.5Q^2$$

$$C_v = 1.2$$

$$A = 20$$

at percent of stem stroke = 50 %.

$$x = \frac{50}{100} - 1 = -0.5$$

$$\frac{Q}{C_v \sqrt{\Delta p}} = A^x$$

$$\frac{Q}{1.2 \sqrt{80 - 2.5Q^2}} = 20^{-0.5}$$

$$Q = 0.26833 \sqrt{80 - 2.5Q^2}$$

$$Q = 2.21 \text{ L/s} \text{ --- Ans.}$$

Comparing to linear-characteristic valve in Fig. 9-27.

$$Q = \frac{\text{percent stroke}}{100} C_v \sqrt{\Delta p}$$

$$Q = \frac{50}{100} (1.2) \sqrt{80 - 2.5Q^2}$$

$$Q = 3.893 \text{ L/s} > 2.21 \text{ L/s}$$

- 10-1. A Carnot refrigeration cycle absorbs heat at -12 C and rejects it at 40 C.
- Calculate the coefficient of performance of this refrigeration cycle.
 - If the cycle is absorbing 15 kW at the -12 C temperature, how much power is required?
 - If a Carnot heat pump operates between the same temperatures as the above refrigeration cycle, what is the performance factor?
 - What is the rate of heat rejection at the 40 C temperature if the heat pump absorbs 15 kW at the -12 C temperature?

Solution:

- Coefficient of performance = $T_1 / (T_2 - T_1)$
 $T_1 = -12\text{ C} + 273 = 261\text{ K}$
 $T_2 = 40\text{ C} + 273 = 313\text{ K}$
 Coefficient of performance = $261 / (261 + 313)$
 Coefficient of performance = **5.02 - - - Ans.**
- Coefficient of performance = useful refrigeration / net work
 $5.02 = 15\text{ kw} / \text{net work}$
 net work = **2.988 kW - - - Ans.**
- Performance factor = coefficient of performance + 1
 Performance factor = **6.01 - - - Ans.**
- Performance factor = heat rejected from cycle / work required.

$$\text{Performance factor} = \frac{\text{heat rejected}}{\text{heat rejected} - 15\text{kw}}$$

$$6.02 = \frac{\text{heat rejected}}{\text{heat rejected} - 15\text{kw}}$$

$$\text{Heat rejected} = \mathbf{17.988\text{ kw} - - - \text{Ans.}}$$

- 10-2. If in a standard vapor-compression cycle using refrigerant 22 the evaporating temperature is -5 C and the condensing temperature is 30 C, sketch the cycle on pressure-enthalpy coordinates and calculate (a) the work of compression, (b) the refrigerating effect, and (c) the heat rejected in the condenser, all in kilojoules per kilograms, and (d) the coefficient of performance.

Solution.

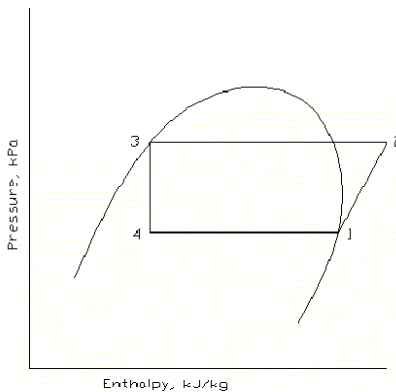

At point 1, Table A-6, -5 C,
 $h_1 = 403.496\text{ kJ/kg}$
 $s_1 = 1.75928\text{ kJ/kg.K}$

At point 2, 30 C condensing temperature, constant entropy, Table A-7.

$$h_2 = 429.438 \text{ kJ/kg}$$

At point 3, Table A-6, 30 C

$$h_3 = 236.664 \text{ kJ/kg}$$

$$h_4 = h_3 = 236.664 \text{ kJ/kg}$$

(a) Work of compression = $h_2 - h_1$
 = $429.438 - 403.496$
 = **25.942 kJ/kg - - - Ans.**

(b) Refrigerating effect = $h_1 - h_4$
 = $403.496 - 236.664$
 = **166.832 kJ/kg - - - Ans.**

(c) Heat rejected = $h_2 - h_3$
 = $429.438 - 236.664$
 = **192.774 kJ/kg - - - Ans.**

(d) Coefficient of performance

$$\text{Coefficient of performance} = \frac{h_1 - h_4}{h_2 - h_1}$$

$$\text{Coefficient of performance} = \frac{403.496 - 236.664}{429.438 - 403.496}$$

$$\text{Coefficient of performance} = \mathbf{6.43 - - - Ans.}$$

10-3. A refrigeration system using refrigerant 22 is to have a refrigerating capacity of 80 kw. The cycle is a standard vapor-compression cycle in which the evaporating temperature is -8 C and the condensing temperature is 42 C.

- (a) Determine the volume flow of refrigerant measured in cubic meter per second at the inlet to the compressor.
- (b) Calculate the power required by the compressor.
- (c) At the entrance to the evaporator what is the fraction of vapor in the mixture expressed both on a mass basis and a volume basis?

Solution:

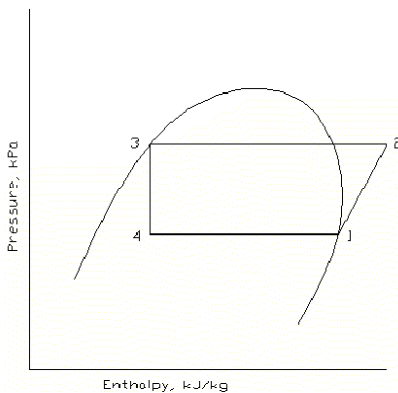

At 1, Table A-6, -8 C.

$$h_1 = h_{g1} = 402.341 \text{ kJ/kg}$$

$$h_{f1} = 190.718 \text{ kJ/kg}$$

$$v_{g1} = 61.0958 \text{ L/kg}$$

$$v_{f1} = 0.76253 \text{ L/kg}$$

$$s_1 = 1.76394 \text{ kJ/kg.K}$$

At 2, 42 C condensing temperature, constant entropy, Table A-7.

$$h_2 = 438.790 \text{ kJ/kg}$$

At 3, Table A-6, 42 C

$$h_3 = 252.352 \text{ kJ/kg}$$

$$h_4 = h_3 = 252.352 \text{ kJ/kg}$$

(a) Volume flow of refrigerant = wv_g
 $w(h_1 - h_4) = 80 \text{ kw}$
 $w(402.341 - 252.352) = 80$
 $w = 0.5334 \text{ kg/s}$

Volume flow of refrigerant
 $= (0.5334 \text{ kg/s})(61.0958 \text{ L/kg})$
 $= 32.59 \text{ L/s}$
 $= \mathbf{0.03259 \text{ m}^3/\text{s} \text{ --- Ans.}}$

(b) Power required by compressor
 $= w(h_2 - h_1)$
 $= (0.5334)(438.790 - 402.341)$
 $= \mathbf{19.442 \text{ kw} \text{ --- Ans.}}$

(c) Let x_m = fraction of vapor by mass basis and
 x_v = fraction of vapor by volume basis.

Mass Basis:

$$x_m = \frac{h_4 - h_{f1}}{h_{g1} - h_{f1}} = \frac{252.352 - 190.718}{402.341 - 190.718}$$

$$\mathbf{x_m = 0.292 \text{ --- Ans.}}$$

Volume Basis:

Total volume = $(1 - 0.292)(0.76253) + 0.292(61.0958) = 18.38 \text{ L/s}$

$$x_v = \frac{0.292(61.0958)}{18.38}$$

$$\mathbf{x_v = 0.971 \text{ --- Ans.}}$$

10-4. Compare the coefficient of performance of a refrigeration cycle which uses wet compression with that of one which uses dry compression. In both cases use ammonia as the refrigerant, a condensing temperature of 30 C, and an evaporating temperature of -20 C; assume that the compressors are isentropic and that the liquid leaving the condenser is saturated. In the wet-compression cycle the refrigerant enters the compressor in such a condition that it is saturated vapor upon leaving the compressor.

Solution:

For Dry Compression:

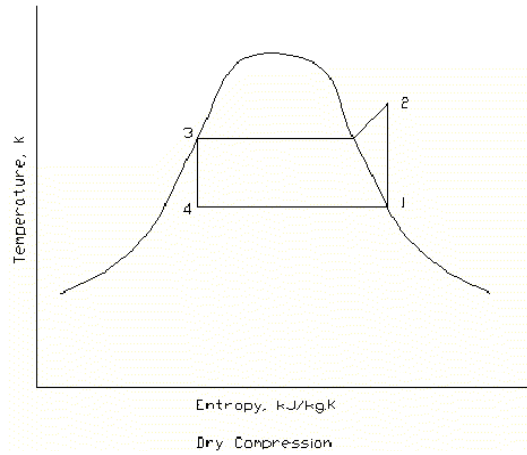

At 1, -20 C, Table A-3.

$$h_1 = h_g = 1437.23 \text{ kJ/kg}$$

$$h_f = 108.599 \text{ kJ/kg}$$

$$s_1 = s_g = 5.9025 \text{ kJ/kg.K}$$

$$s_f = 0.65436 \text{ kJ/kg.K}$$

At 2, 30 C Condensing Temperature, constant entropy, Fig. A-1.

$$h_2 = 1704 \text{ kJ/kg}$$

At 3, 30 C, Table A-3.

$$h_3 = 341.769 \text{ kJ/kg}$$

$$s_3 = 1.48762 \text{ kJ/kg.K}$$

At 4, $s_4 = s_3$,

$$x = \frac{s_4 - s_f}{s_g - s_f} = \frac{1.48762 - 0.65436}{5.9025 - 0.65436} = 0.1588$$

$$h_4 = h_f + x(h_g - h_f)$$

$$h_4 = 108.599 + (0.1588)(1437.23 - 108.599) = 319.586 \text{ kJ/kg}$$

$$\text{Coefficient of performance} = \frac{h_1 - h_4}{h_2 - h_1} = \frac{1437.23 - 319.586}{1704 - 1437.23}$$

$$\text{Coefficient of performance} = 4.19$$

For Wet Compression:

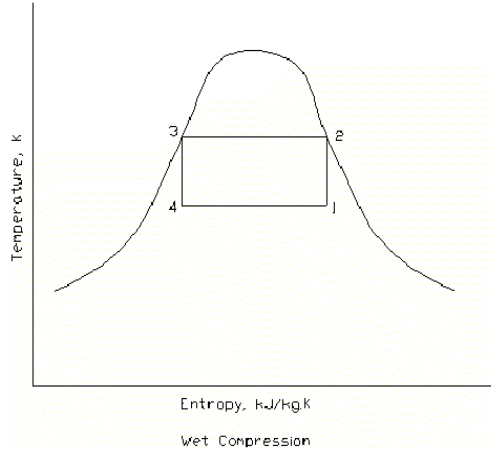

At 2, 30 C condensing temperature, saturated, Table A-3.

$$h_2 = 1486.14 \text{ kJ/kg}$$

$$s_2 = 5.2624 \text{ kJ/kg.K}$$

At 1, $s_1 = s_2$.

$$x = \frac{s_1 - s_f}{s_g - s_f} = \frac{5.2624 - 0.65436}{5.9025 - 0.65436} = 0.878$$

$$h_1 = h_f + x (h_g - h_f)$$

$$h_1 = 108.599 + (0.878)(1437.23 - 108.599)$$

$$h_1 = 1275.14 \text{ kJ/kg}$$

$$h_3 = 341.769 \text{ kJ/kg}$$

$$h_4 = 319.586 \text{ kJ/kg}$$

$$\text{Coefficient of performance} = \frac{h_1 - h_4}{h_2 - h_1} = \frac{1275.14 - 319.586}{1486.14 - 1275.14}$$

$$\text{Coefficient of performance} = 4.53$$

Ans. 4.53 wet versus 4.19 dry.

10-5. In the vapor-compression cycle a throttling device is used almost universally to reduce the pressure of the liquid refrigerant.

- Determine the percent saving in net work of the cycle per kilograms of refrigerant if an expansion engine would be used to expand saturated liquid refrigerant 22 isentropically from 35 C to the evaporator temperature of 0 C. Assume that compression is isentropic from saturated vapor at 0 C to a condenser pressure corresponding to 35 C.
- Calculate the increase in refrigerating effect in kilojoules per kilograms resulting from use of expansion engine.

Solution:

Vapor-Compression Cycle:

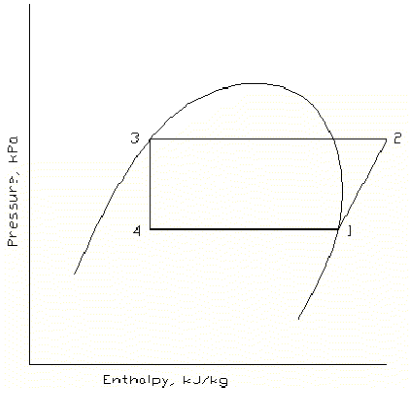

At 1, 0 C, Table A-6.
 $h_1 = 405.361 \text{ kJ/kg}$
 $s_1 = s_{g1} = 1.75279 \text{ kJ/kg.K}$

At 2, 35 C, constant entropy, Table A-7.
 $h_2 = 430.504 \text{ kJ/kg}$

At 3, Table A-6
 $h_3 = 243.114 \text{ kJ/kg}$

$h_4 = h_3 = 243.114 \text{ kJ/kg}$

Net Work = $h_2 - h_1 = 430.504 - 405.361 = 25.143 \text{ kJ/kg}$
 Refrigerating Effect = $h_1 - h_4 = 405.361 - 243.114 = 162.247 \text{ kJ/kg}$

For expansion engine:

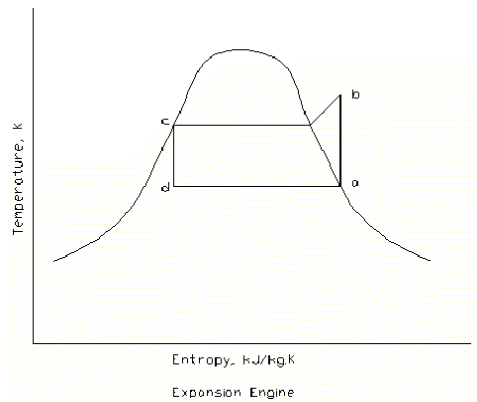

At a, 0 C, Table A-6.
 $h_a = h_{ga} = 405.361 \text{ kJ/kg}$
 $h_{fa} = 200 \text{ kJ/kg}$
 $s_a = s_{ga} = 1.75279 \text{ kJ/kg.K}$
 $s_{fa} = 1.00000 \text{ kJ/kg.K}$

At b, constant entropy, Table A-2

$$h_b = 430.504 \text{ kJ/kg}$$

At c, Table A-6.

$$h_c = 243.114 \text{ kJ/kg}$$

$$s_c = 1.14594 \text{ kJ/kg}$$

At d, constant entropy.

$$x = \frac{s_d - s_{fa}}{s_{ga} - s_{fa}} = \frac{1.14594 - 1.00000}{1.75279 - 1.00000} = 0.193866$$

$$h_d = h_{fa} + x(h_{ga} - h_{fa})$$

$$h_d = 200 + (0.193866)(405.361 - 200)$$

$$h_d = 239.813 \text{ kJ/kg}$$

$$\text{Net Work} = (h_b - h_a) - (h_c - h_d)$$

$$\text{Net Work} = (430.5 - 405.361) - (243.114 - 239.813)$$

$$\text{Net Work} = 21.838 \text{ kJ/kg}$$

$$\text{Refrigerating Effect} = h_a - h_d = 405.361 - 239.813 = 165.548 \text{ kJ/kg}$$

(a) Percent Saving

$$= \frac{25.143 - 21.838}{25.143} (100\%)$$

$$= 13.1\% \text{ --- Ans.}$$

(b) Increase in refrigerating effect.

$$= 165.548 \text{ kJ/kg} - 162.247 \text{ kJ/kg}$$

$$= 3.301 \text{ kJ/kg} \text{ --- Ans.}$$

- 10-6. Since a refrigeration system operates more efficiently when the condensing temperature is low, evaluate the possibility of cooling the condenser cooling water of the refrigeration system in question with another refrigeration system. Will the compressor performance of the two systems be better, the same, or worse than one individual system? Explain why.

Solution:

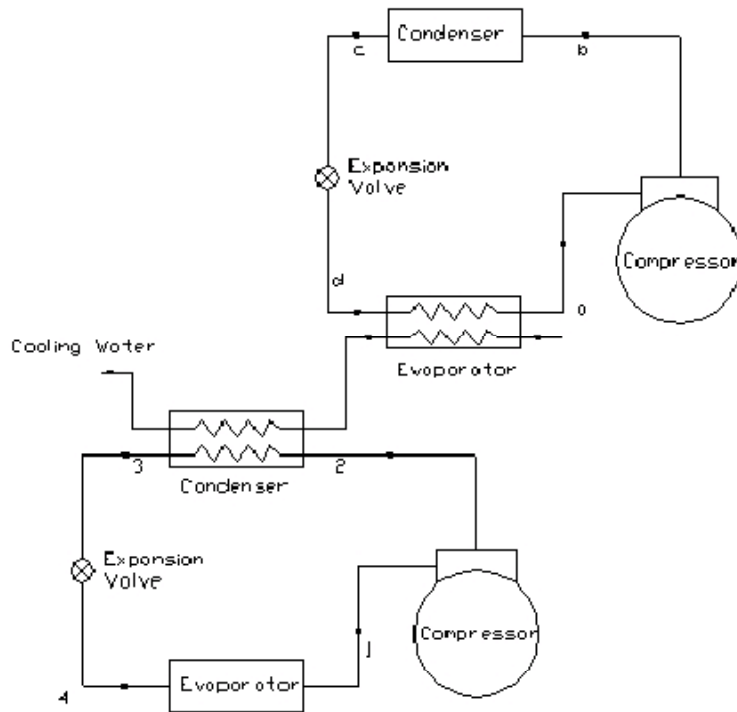

Coefficient of performance of two system:

$$COP_c = \frac{w_1(h_1 - h_4) + w_a(h_a - h_d)}{w_1(h_2 - h_1) + w_a(h_b - h_a)}$$

Coefficient of performance of each system

$$COP_1 = \frac{w_1(h_1 - h_4)}{w_1(h_2 - h_1)}$$

$$COP_2 = \frac{w_a(h_a - h_d)}{w_a(h_b - h_a)}$$

Substituting:

$$COP_c = \frac{w_1(h_1 - h_4) + w_a(h_a - h_d)}{\frac{w_1(h_1 - h_4)}{COP_1} + \frac{w_a(h_a - h_d)}{COP_2}}$$

if $COP_1 = COP_2$ then:

$$COP_c = COP_1 = COP_2$$

Therefore it is the same COP as for individual system having equal COP and in between if COP is not the same..Ans.

10-7. A refrigerant 22 vapor compression system includes a liquid-to-suction heat exchanger in the system. The heat exchanger warms saturated vapor coming from the evaporator from -10 to 5 C with liquid which comes from the condenser at 30 C. The compressions are isentropic in both cases listed below.

- Calculate the coefficient of performance of the system without the heat exchanger but with the condensing temperature at 30 C and an evaporating temperature of -10 C.
- Calculate the coefficient of performance of the system with the heat exchanger?
- If the compressor is capable of pumping 12.0 L/s measured at the compressor suction, what is the

- (d) refrigeration capacity of the system without the heat exchanger?
 With the same compressor capacity as in (c), what is the refrigerating capacity of the system with the heat exchanger?

Solution:

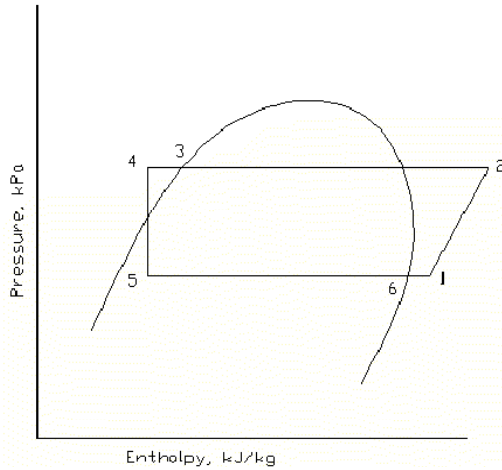

- (a) Without heat exchanger
 At 1,6, -10 C, Table A-6.
 $h_1 = 401.555 \text{ kJ/kg}$
 $s_1 = 1.76713 \text{ kJ/kg.K}$
 At 2, 30 C, constant entropy, Table A-7
 $h_2 = 431.787 \text{ kJ/kg}$
 At 3,4 , 30 C, Table A-6.
 $h_3 = 236.664 \text{ kJ/kg}$
 At 5, $h_5 = h_3 = 236.664 \text{ kJ/kg}$

$$\text{coefficient of performance} = \frac{h_1 - h_5}{h_2 - h_1} = \frac{401.555 - 236.664}{431.787 - 401.555}$$

coefficient of performance = 5.46 . . . Ans.

- (b) With heat exchanger
 At 6, -10 C , Table A-6
 $h_6 = 401.555 \text{ kJ/kg}$
 At 1, -10 C evaporator temperature, 5 C, Table A-7
 $h_1 = 411.845 \text{ kJ/kg}$
 At 2, 30 C, constant entropy, Table A-7
 $h_2 = 444.407 \text{ kJ/kg}$
 At 3, 30 C, table A-6
 $h_3 = 236.664 \text{ kJ/kg}$.

Since no mention of subcooling.

$$h_5 = h_4 = h_3 = 236.664 \text{ kJ/kg}$$

$$\text{coefficient of performance} = \frac{h_1 - h_5}{h_2 - h_1} = \frac{411.845 - 236.664}{444.407 - 411.845}$$

coefficient of performance = 5.38 . . . Ans.

- (c) Refrigerating capacity without heat exchanger
At 1, $v = 65.3399 \text{ L/kg}$

Refrigerating Capacity

$$= \left(\frac{12.0 \text{ L/s}}{65.3399 \text{ L/kg}} \right) (h_1 - h_5)$$

$$= \left(\frac{12.0 \text{ L/s}}{65.3399 \text{ L/kg}} \right) (401.555 - 236.664)$$

= 30.3 kW - - - - Ans.

- (d) Refrigerating capacity with heat exchanger
At 1, $v = 70.2751 \text{ L/kg}$

Refrigerating Capacity

$$= \left(\frac{12.0 \text{ L/s}}{70.2751 \text{ L/kg}} \right) (h_1 - h_5)$$

$$= \left(\frac{12.0 \text{ L/s}}{70.2751 \text{ L/kg}} \right) (411.845 - 236.664)$$

= 29.9 kW - - - - Ans.

- 0 0 0 -

- 11-1. An ammonia compressor has a 5 percent clearance volume and a displacement rate of 80 L/s and pumps against a condensing temperature of 40 C. For the two different evaporating temperatures of -10 and 10 C, compute the refrigerant flow rate assuming that the clearance volumetric efficiency applies.

Solution:

Equation 11-7.

$$w = \text{displacement rate} \times \frac{\eta_{vc}/100}{v_{suc}}$$

(a) At -10 C, Table A-3.

$$s_1 = 5.7550 \text{ kJ/kg}$$

$$v_{suc} = 417.477 \text{ L/kg}$$

At 40 C, constant entropy, Fig. A-1

$$v_{dis} = 112.5 \text{ L/kg}$$

$$m = 5 \%$$

Equation 11-4 and Equation 11-5.

$$\eta_{vc} = 100 - m \left(\frac{v_{suc}}{v_{dis}} - 1 \right)$$

$$\eta_{vc} = 100 - 5 \left(\frac{417.477}{112.5} - 1 \right) = 86.445$$

$$w = \text{displacement rate} \times \frac{\eta_{vc}/100}{v_{suc}}$$

$$w = (80 \text{ L/s}) \times \frac{(86.445/100)}{417.477}$$

w = 0.166 kg/s at -10 C --- Ans.

(b) At 10 C, Table A-3

$$s_1 = 5.4924 \text{ kJ/kg.K}$$

$$v_{suc} = 205.22 \text{ L/kg}$$

At 40 C, constant entropy, Fig. A-1

$$v_{dis} = 95 \text{ L/kg}$$

$$m = 5 \%$$

Equation 11-4 and Equation 11-5.

$$\eta_{vc} = 100 - m \left(\frac{v_{suc}}{v_{dis}} - 1 \right)$$

$$\eta_{vc} = 100 - 5 \left(\frac{205.22}{95} - 1 \right) = 94.199$$

$$w = \text{displacement rate} \times \frac{\eta_{vc}/100}{v_{suc}}$$

$$w = (80 \text{ L/s}) \times \frac{(94.199/100)}{205.22}$$

w = 0.367 kg/s at 10 C --- Ans.

11-2. A refrigerant 22 compressor with a displacement rate of 60 L/s operates in a refrigeration system that maintains a constant condensing temperature of 30 C. Compute and plot the power requirement of this compressor at evaporating temperatures of -20, -10, 0, 10 and 20 C. Use the actual volumetric efficiencies from Fig. 11-12 and the following isentropic works of compression for the five evaporating temperatures, respectively, 39.9, 30.2, 21.5, 13.7, and 6.5 kJ/kg.

Solution:

(a) At -20 C evaporating temperature, Table A-6.

$$v_{suc} = 92.8432 \text{ L/kg}$$

$$p_{suc} = 244.83 \text{ kPa}$$

Table A-7, 30 C

$$p_{dis} = 1191.9 \text{ kPa}$$

$$\text{Ratio} = p_{dis} / p_{suc} = 1191.9 \text{ kPa} / 244.82 \text{ kPa} = 4.87$$

Figure 11-12

$$\eta_{va} = \text{volumetric efficiency} = 67.5 \%$$

$$w = \text{displacement rate} \times \frac{\eta_{va}/100}{v_{suc}}$$

$$w = (60 \text{ L/s}) \times \frac{(67.5/100)}{92.8432}$$

$$w = 0.4362 \text{ kg/s at -20 C}$$

$$P = w\Delta h_i$$

$$\Delta h_i = 39.9 \text{ kJ/kg}$$

$$P = (0.4362)(39.9)$$

$$P = 17.4 \text{ kw at -20 C}$$

(b) At -10 C evaporating temperature, Table A-6.

$$v_{suc} = 65.3399 \text{ L/kg}$$

$$p_{suc} = 354.3 \text{ kPa}$$

Table A-7, 30 C

$$p_{dis} = 1191.9 \text{ kPa}$$

$$\text{Ratio} = p_{dis} / p_{suc} = 1191.9 \text{ kPa} / 354.30 \text{ kPa} = 3.364$$

Figure 11-12

$$\eta_{va} = \text{volumetric efficiency} = 77.5 \%$$

$$w = \text{displacement rate} \times \frac{\eta_{va}/100}{v_{suc}}$$

$$w = (60 \text{ L/s}) \times \frac{(77.5/100)}{65.3399}$$

$$w = 0.7117 \text{ kg/s at } -10 \text{ C}$$

$$P = w\Delta h_i$$

$$\Delta h_i = 30.2 \text{ kJ/kg}$$

$$P = (0.7117)(30.2)$$

$$P = 21.5 \text{ kw at } -10 \text{ C}$$

(c) At 0 C evaporating temperature, Table A-6.

$$v_{\text{suc}} = 47.1354 \text{ L/kg}$$

$$p_{\text{suc}} = 497.59 \text{ kPa}$$

Table A-7, 30 C

$$p_{\text{dis}} = 1191.9 \text{ kPa}$$

$$\text{Ratio} = p_{\text{dis}} / p_{\text{suc}} = 1191.9 \text{ kPa} / 497.59 \text{ kPa} = 2.4$$

Figure 11-12

$$\eta_{\text{va}} = \text{volumetric efficiency} = 83 \%$$

$$w = \text{displacement rate} \times \frac{\eta_{\text{vc}}/100}{v_{\text{suc}}}$$

$$w = (60 \text{ L/s}) \times \frac{(83/100)}{47.1354}$$

$$w = 1.0565 \text{ kg/s at } 0 \text{ C}$$

$$P = w\Delta h_i$$

$$\Delta h_i = 21.5 \text{ kJ/kg}$$

$$P = (1.0565)(21.5)$$

$$P = 22.7 \text{ kw at } 0 \text{ C}$$

(d) At 10 C evaporating temperature, Table A-6.

$$v_{\text{suc}} = 34.7136 \text{ L/kg}$$

$$p_{\text{suc}} = 680.70 \text{ kPa}$$

Table A-7, 30 C

$$p_{\text{dis}} = 1191.9 \text{ kPa}$$

$$\text{Ratio} = p_{\text{dis}} / p_{\text{suc}} = 1191.9 \text{ kPa} / 680.70 \text{ kPa} = 1.75$$

Figure 11-12

$$\eta_{\text{va}} = \text{volumetric efficiency} = 86.7 \%$$

$$w = \text{displacement rate} \times \frac{\eta_{\text{vc}}/100}{v_{\text{suc}}}$$

$$w = (60 \text{ L/s}) \times \frac{(86.7/100)}{34.7136}$$

$$w = 1.4986 \text{ kg/s at } 10 \text{ C}$$

$$P = w\Delta h_i$$

$$\Delta h_1 = 13.7 \text{ kJ/kg}$$

$$P = (1.4986)(13.7)$$

$$P = 20.5 \text{ kw at } 10 \text{ C}$$

- (e) At 20 C evaporating temperature, Table A-6.
 $v_{\text{suc}} = 26.0032 \text{ L/kg}$
 $p_{\text{suc}} = 909.93 \text{ kPa}$
 Table A-7, 30 C
 $p_{\text{dis}} = 1191.9 \text{ kPa}$

$$\text{Ratio} = p_{\text{dis}} / p_{\text{suc}} = 1191.9 \text{ kPa} / 909.93 \text{ kPa} = 1.31$$

Figure 11-12

$$\eta_{\text{va}} = \text{volumetric efficiency} = 89.2 \%$$

$$w = \text{displacement rate} \times \frac{\eta_{\text{vc}} / 100}{v_{\text{suc}}}$$

$$w = (60 \text{ L/s}) \times \frac{(89.2 / 100)}{26.0032}$$

$$w = 2.0583 \text{ kg/s at } 20 \text{ C}$$

$$P = w\Delta h_1$$

$$\Delta h_1 = 6.5 \text{ kJ/kg}$$

$$P = (2.0583)(6.5)$$

$$P = 13.4 \text{ at } 20 \text{ C}$$

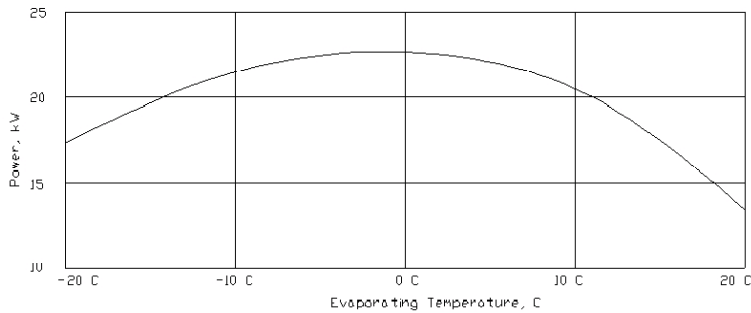

- 11-3. The catalog for a refrigerant 22, four-cylinder, hermetic compressor operating at 29 r/s. a condensing temperature of 40 C and an evaporating temperature of -4 C shows a refrigeration capacity of 115 kw. At this operating points the motor (whose efficiency is 90 percent) draws 34.5 kW. The bore of the cylinders is 87 mm and the piston stroke is 70 mm. The performance data are based on 8C of subcooling of the liquid leaving the condenser. Compute (a) the actual volumetric efficiency and (b) the compression efficiency.

Solution: Table A-6, -4 C evaporating temperature.

$$h_1 = 403.876 \text{ kJ/kg}$$

$$v_{\text{suc}} = 53.5682 \text{ L/kg}$$

$$s_1 = 1.75775 \text{ kJ/kg.K}$$

At 2, table A-7, constant entropy, 40 condensing temperature

$$h_2 = 435.391 \text{ kJ/kg}$$

$$v_{\text{dis}} = 17.314 \text{ L/kg}$$

At 3, 40 C condensing temperature, Table A-6, 8 C Subcooling
 $t = 40 - 8 = 32 \text{ C}$
 $h_3 = 239.23 \text{ kJ/kg}$

$$h_4 = h_3 = 239.23 \text{ kJ/kg}$$

(a) For actual volumetric efficiency

$$\begin{aligned} \text{Displacement rate} &= (4 \text{ cyl})(29 \text{ r/s})(0.087^2 \pi / 4 \text{ m}^3/\text{cyl.r})(0.070 \text{ m}) \\ &= 0.04827 \text{ m}^3/\text{kg} = 48.27 \text{ L/kg} \end{aligned}$$

Actual rate of refrigerant flow

$$= 115 \text{ kw} / (403.876 - 239.23 \text{ kJ/kg}) = 0.6985 \text{ kg/s}$$

Actual volumetric flow rate at the compressor suction

$$\begin{aligned} &= (0.6985 \text{ kg/s})(53.5682 \text{ L/kg}) \\ &= 37.42 \text{ L/s} \end{aligned}$$

$$\eta_{va} = \frac{\text{volume flow rate entering compressor, m}^3/\text{s}}{\text{displacement rate of compression, m}^3/\text{s}} \times 100$$

$$\eta_{va} = (37.42 \text{ L/s})(100) / (48.27 \text{ L/s}) = 77.5 \% \text{ --- Ans.}$$

(b) For compression efficiency.

Actual work of compression

$$= 0.9 (34.5 \text{ kW}) / (0.6985 \text{ kg/s}) = 44.45 \text{ kJ/kg}$$

$$\eta_c = \frac{\text{isentropic work of compression, kJ/kg}}{\text{actual work of compression, kJ/kg}} \times 100$$

$$\eta_c = \frac{435.391 - 403.876 \text{ kJ/kg}}{44.45 \text{ kJ/kg}} \times 100$$

$$\eta_c = 70.9 \% \text{ --- Ans.}$$

- 11-4. An automobile air conditioner using refrigerant 12 experiences a complete blockage of the airflow over the condenser, so that the condenser pressure rises until the volumetric efficiency drops to zero. Extrapolate the actual volumetric-efficiency curve of Fig. 11-12 to zero and estimate the maximum discharge pressure, assuming an evaporating temperature of 0 C.

Solution:

Figure 11-12.

At actual volumetric efficiency = -

$$\text{Pressure ratio} = 5 + \frac{(0 - 67)}{(56 - 67)} (7 - 5) = 17.18$$

Table A-5, 0 C, $p_{\text{suc}} = 308.61 \text{ kPa}$

$$p_{\text{dis}} = (17.18)(308.61 \text{ kPa})$$

$$p_{\text{dis}} = 5302 \text{ kPa --- Ans.}$$

- 11-5. Compute the maximum displacement rate of a two-vane compressor having a cylinder diameter of 190 mm and a rotor 80 mm long with a diameter of 170 mm. The compressor operates at 29 r/s.

Solution: Use Fig. 11-20 (a)

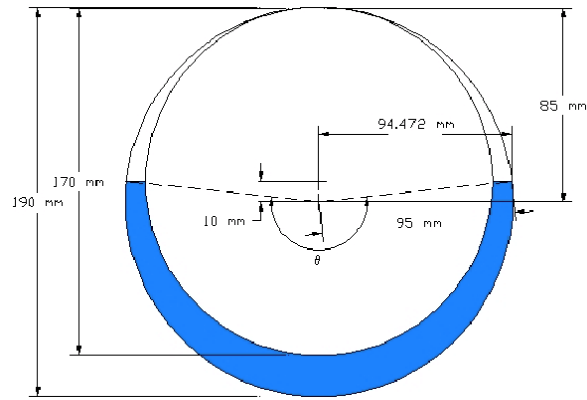

$$\theta = 3.3525 \text{ radians}$$

$$\text{Crosshatched area} = (1/2)(3.3525)(0.095)^2 + (1/2)(0.094472)(0.010)(2) - (\pi/2)(0.085)^2$$

$$\text{Crosshatched area} = 0.004724 \text{ m}^2.$$

Displacement rate for two-vane compressor

$$D = 2(\text{Crosshatched area})(L)(\text{rotative speed})$$

$$D = (2)(0.004724)(0.080)(29)$$

$$D = 0.0219 \text{ m}^3/\text{s}$$

$$\mathbf{D = 21.9 \text{ L/s} \text{ --- Ans.}}$$

- 11-6. A two-stage centrifugal compressor operating at 60 r/s is to compress refrigerant 11 from an evaporating temperature of 4 C to a condensing temperature of 35 C. If both wheels are to be of the same diameter, what is this diameter?

Solution:

At 4 C evaporating temperature, Table A-4.

$$h_1 = 390.93 \text{ kJ/kg}$$

$$s_1 = 1.68888 \text{ kJ/kg.K}$$

At 35 C condensing temperature, Fig. A-2, constant entropy,

$$h_2 = 410 \text{ kJ/kg}$$

$$w = 60 \text{ r/s}$$

Equation 11-16,

$$V_{2t}^2 = 1000\Delta h_1$$

$$V_{2t}^2 = 1000(410 - 390.93)/2$$

$$V_{2t} = 97.65 \text{ m/s per stage}$$

Section 11-25. Refrigerant 11. 113.1 m/s tip speed,

wheel diameter = 0.60 m

then at 97.65 m/s tip speed.

$$\text{wheel diameter} = (97.65 / 113.1)(0.6 \text{ m})$$

$$\mathbf{\text{wheel diameter} = 0.52 \text{ m} \text{ --- Ans.}}$$

- 0 0 0 -

- 12-1. An air-cooled condenser is to reject 70 kw of heat from a condensing refrigerant to air. The condenser has an air-side area of 210 m² and a U value based on this area is 0.037 kW/m².K; it is supplied with 6.6 m³/s of air, which has a density of 1.15 kg/m³. If the condensing temperature is to be limited to 55 C, what is the maximum allowable temperature of inlet air?

Solution: $A_o = 210 \text{ m}^2$

$$U_o = 0.037 \text{ kW/m}^2 \cdot \text{K}$$

$$q = 70 \text{ kw}$$

$$\rho = 1.15 \text{ kg/m}^3$$

$$\text{Condensing Temperature} = 55 \text{ C}$$

$$w = (6.6 \text{ m}^3/\text{s}) / (1.15 \text{ kg/m}^3) = 5.739 \text{ kg/s}$$

$$c_p = 1.0 \text{ kJ/kg.K}$$

$$\text{LMTD} = \frac{(t_c - t_i) - (t_c - t_o)}{\ln \left[\frac{(t_c - t_i)}{(t_c - t_o)} \right]}$$

$$q = U_o A_o \text{LMTD}$$

$$\text{LMTD} = \frac{q}{U_o A_o} = \frac{70}{(0.037)(210)} = 9.009 \text{ K}$$

$$\text{But } q = wc_p(t_o - t_i)$$

$$t_o - t_i = \frac{q}{wc_p} = \frac{70}{(5.739)(1)} = 12.197 \text{ K}$$

$$\text{LMTD} = \frac{(t_c - t_i) - (t_c - t_o)}{\ln \left[\frac{(t_c - t_i)}{(t_c - t_o)} \right]}$$

$$9.009 = \frac{12.197}{\ln \left[\frac{(55 - t_i)}{(55 - t_o)} \right]}$$

$$\frac{55 - t_i}{55 - t_o} = 3.8724$$

$$55 - t_i = 3.8724(55 - 12.197 - t_i)$$

$$t_i = 38.6 \text{ C} \text{ --- Ans.}$$

- 12-2. An air-cooled condenser has an expected U value of 30 W/m².K based on the air-side area. The condenser is to transfer 60 kW with an airflow rate of 15 kg/s entering at 35 C. If the condenser temperature is to be 48 C, what is the required air-side area?

Solution:

$$q = U_o A_o \text{LMTD}$$

$$q = wc_p(t_o - t_i)$$

$$w = 15 \text{ kg/s}$$

$$c_p = 1.0 \text{ kJ/kg.K}$$

$$t_o = t_i + \frac{q}{wc_p}$$

$$t_o = 35 + \frac{60}{(15)(1)}$$

$$t_o = 39 \text{ C}$$

$$LMTD = \frac{(t_o - t_i)}{\ln \left[\frac{(t_c - t_i)}{(t_c - t_o)} \right]}$$

$$LMTD = \frac{(39 - 35)}{\ln \left[\frac{(48 - 35)}{(48 - 39)} \right]} = 10.878 \text{ K}$$

$$q = U_o A_o LMTD$$

$$60 \text{ kw} = (30 / 1000)(A_o)(10.878)$$

$$A_o = 184 \text{ m}^2 \text{ --- Ans.}$$

12-3. A refrigerant 22 condenser has four water passes and a total of 60 copper tubes that are 14 mm ID and have 2 mm wall thickness. The conductivity of copper is 390 W/m.K. The outside of the tubes is finned so that the ratio of outside to inside area is 1.7. The cooling-water flow through the condenser tubes is 3.8 L/s.

- (a) Calculate the water-side coefficient if the water is at an average temperature of 30 C, at which temperature $k = 0.614 \text{ W/m.K}$, $\rho = 996 \text{ kg/m}^3$, and $\mu = 0.000803 \text{ Pa.s}$.
- (b) Using a mean condensing coefficient of $1420 \text{ W/m}^2.\text{K}$, calculate the overall heat-transfer coefficient based on the condensing area.

Solution:

- (a) Water-side coefficient:
Eq. 12-19.

$$\frac{hD}{k} = 0.023 \left(\frac{VD\rho}{\mu} \right)^{0.8} \left(\frac{c_p\mu}{k} \right)^{0.4}$$

$$D = 14 \text{ mm} = 0.014 \text{ m}$$

$$k = 0.614 \text{ W/m.K}$$

$$\rho = 996 \text{ kg/m}^3$$

$$\mu = 0.000803 \text{ Pa.s}$$

$$c_p = 4190 \text{ J/kg.K}$$

$$V = \frac{3.8 \times 10^{-3} \text{ m}^3/\text{s}}{\left(\frac{60}{4} \right) \left(\frac{\pi}{4} \right) (0.014 \text{ m})^2}$$

$$V = 1.6457 \text{ m/s}$$

$$\frac{h(0.014)}{0.614} = 0.023 \left(\frac{(1.6457)(0.014)(996)}{0.000803} \right)^{0.8} \left(\frac{(4190)(0.000803)}{0.614} \right)^{0.4}$$

$$h = 7,313 \text{ W/m}^2.\text{K} \text{ --- Ans.}$$

- (b) Overall heat-transfer coefficient.
Eq. 12-8.

$$\frac{1}{U_o A_o} = \frac{1}{h_o A_o} + \frac{x}{k A_m} + \frac{1}{h_i A_i}$$

$$\frac{1}{U_o} = \frac{1}{h_o} + \frac{x A_o}{k A_m} + \frac{A_o}{h_i A_i}$$

$$h_o = 1420 \text{ W/m}^2.\text{K}$$

$$k = 390 \text{ W/m.K}$$

$$A_o / A_i = 1.7$$

$$A_m = \frac{1}{2}(A_o + A_i)$$

$$A_m = \frac{1}{2}\left(A_o + \frac{A_o}{1.7}\right)$$

$$A_o / A_m = 1.25926$$

$$x = 2 \text{ mm} = 0.002 \text{ m}$$

$$h_i = 7,313 \text{ W/m}^2.\text{K}$$

$$\frac{1}{U_o} = \frac{1}{1420} + \frac{(0.002)(1.2596)}{390} + \frac{1.7}{7313}$$

$$U_o = 1060 \text{ W/m}^2.\text{K} \text{ --- Ans.}$$

- 12-4. A shell-and-tube condenser has a U value of 800 W/m².K based on the water-side area and a water pressure drop of 50 kPa. Under this operating condition 40 percent of the heat-transfer resistance is on the water side. If the water-flow rate is doubled, what will the new U value and the new pressure drop be?

Solution:

$$U_1 = 800 \text{ W/m}^2.\text{K}$$

h_1 = Water-side coefficient

$$h_1 = \frac{1}{(0.40)\left(\frac{1}{800}\right)} = 2,000$$

Eq. 12-13, replace 0.6 by 0.8 for condenser.

$$\text{Water-side coefficient} = (\text{const})(\text{flow rate})^{0.8}$$

$$\text{For } w_2 / w_1 = 2$$

$$\frac{h_2}{h_1} = \left(\frac{w_2}{w_1}\right)^{0.8}$$

$$h_2 = (2000)(2)^{0.8} = 3482.2 \text{ W/m}^2.\text{K}$$

$$\text{Remaining resistance} = (0.60)\left(\frac{1}{800}\right) = 0.00075$$

New U-Value:

$$\frac{1}{U_2} = \frac{1}{3482.2} + 0.00075$$

$$U_2 = 964 \text{ W/m}^2.\text{K} \text{ --- Ans.}$$

New Pressure Drop:

Eq. 12-11.

$$\Delta p_2 = \Delta p_1 \left(\frac{w_2}{w_1} \right)^2$$

$$\Delta p_2 = (50)(2)^2$$

$$\Delta p_2 = 200 \text{ kPa} \text{ --- Ans.}$$

- 12-5. (a) Compute the fin effectiveness of a bar fin made of aluminum that is 0.12 mm thick and 20 mm long when $h_f = 28 \text{ W/m}^2 \cdot \text{K}$, the base temperature is 4 C, and the air temperature is 20 C.
- (b) If you are permitted to use twice as much metal for the fin as originally specified in part (a) and you can either double the thickness or double the length, which choice would be preferable in order to transfer the highest rate of heat flow. Why?

Solution:

(a) Aluminum fins
 $k = 202 \text{ W/m} \cdot \text{K}$
 $2y = 0.12 \text{ mm} = 0.00012 \text{ m}$
 $y = 0.00006 \text{ m}$
 $L = 20 \text{ mm} = 0.020 \text{ m}$

$$M = \sqrt{\frac{h_f}{ky}}$$

$$M = \sqrt{\frac{28}{(202)(0.00006)}}$$

$$M = 48.1 \text{ m}^{-1}$$

$$\eta = \frac{\tanh ML}{ML}$$

$$ML = (48.1 \text{ m}^{-1})(0.020 \text{ m}) = 0.962$$

$$\eta = \frac{\tanh(0.962)}{0.962}$$

$$\eta = 0.7746 \text{ ---- Ans.}$$

(b) If the fin thickness is doubled.

$$2y = 0.24 \text{ m} = 0.00024 \text{ m}$$

$$y = 0.00012 \text{ m}$$

$$M = \sqrt{\frac{28}{(202)(0.00012)}}$$

$$M = 33.99 \text{ m}^{-1}$$

$$\eta = \frac{\tanh ML}{ML}$$

$$ML = (33.99 \text{ m}^{-1})(0.020 \text{ m}) = 0.6798$$

$$\eta = \frac{\tanh(0.6798)}{0.6798}$$

$$\eta = 0.87 > 0.7746$$

If the length L is doubled
 $L = 40 \text{ mm} = 0.040 \text{ m}$

$$M = \sqrt{\frac{28}{(202)(0.00006)}}$$

$$M = 48.1 \text{ m}^{-1}$$

$$\eta = \frac{\tanh ML}{ML}$$

$$ML = (48.1 \text{ m}^{-1})(0.040 \text{ m}) = 1.924$$

$$\eta = \frac{\tanh(1.924)}{1.924}$$

$$\eta = 0.498 < 0.7746$$

Ans. Therefore double the fin thickness to improve rate of heat flow with an efficiency of 87 % compared to 77.46 %.

12-6. Compute the fin effectiveness of an aluminum rectangular plate fin of a finned air-cooling evaporator if the fins are 0.18 mm thick and mounted on a 16-mm-OD tubes. The tube spacing is 40 mm in the direction of air flow and 45 mm vertically. The air-side coefficient is $55 \text{ W/m}^2\cdot\text{K}$.

Solution: $h_f = 55 \text{ W/m}^2\cdot\text{K}$

Aluminum Fins, $k = 202 \text{ W/m}\cdot\text{K}$

$2y = 0.00018 \text{ mm}$

$y = 0.00009 \text{ mm}$

$$M = \sqrt{\frac{h_f}{ky}}$$

$$M = \sqrt{\frac{55}{(202)(0.00009)}}$$

$$M = 55 \text{ m}^{-1}$$

Equivalent external radius.

$$\pi \left[(r_e)^2 - \left(\frac{16}{2} \right)^2 \right] = (40)(45) - \pi \left(\frac{16}{2} \right)^2$$

$$r_e = 23.94 \text{ mm} = 0.02394 \text{ m}$$

$$r_i = 8 \text{ mm} = 0.008 \text{ m}$$

$$(r_e - r_i)M = (0.02394 - 0.008)(55) = 0.88$$

$$r_e/r_i = 23.94 \text{ mm} / 8 \text{ mm} = 3$$

From Fig. 12-8/

Fin Effectiveness = 0.68 - - - Ans.

12-7. What is the UA value of a direct-expansion finned coil evaporator having the following areas: refrigerant side, 15 m^2 ; air-side prime, 13.5 m^2 , and air-side extended, 144 m^2 ? The refrigerant-side heat-transfer coefficient is $1300 \text{ W/m}^2\cdot\text{K}$, and the air-side coefficient is $48 \text{ W/m}^2\cdot\text{K}$. The fin effectiveness is 0.64.

Solution: $\eta = 0.64$

$$A_1 = 15 \text{ m}^2$$

$$h_1 = 1300 \text{ W/m}^2\cdot\text{K}$$

$$h_f = 48 \text{ W/m}^2\cdot\text{K}$$

$$A_p = 13.5 \text{ m}^2$$

$$A_e = 144 \text{ m}^2$$

Eq. 12-20 neglect tube resistance.

$$\frac{1}{U_o A_o} = \frac{1}{h_f (A_p + \eta A_e)} + \frac{1}{h_i A_i}$$

$$\frac{1}{U_o A_o} = \frac{1}{(48)(13.5 + 0.64(144))} + \frac{1}{(1300)(15)}$$

$$U_o A_o = 4,025 \text{ W/K} \text{ --- Ans.}$$

- 12-8. A refrigerant 22 system having a refrigerating capacity of 55 kW operates with an evaporating temperature of 5 C and rejects heat to a water-cooled condenser. The compressor is hermetically sealed. The condenser has a U value of 450 W/m².K and a heat-transfer area of 18 m² and receives a flow rate of cooling water of 3.2 kg/s at a temperature of 30 C. What is the condensing temperature?

Solution: Eq. 12-26.

$$LMTD = \frac{(t_c - t_i) - (t_c - t_o)}{\ln \left[\frac{(t_c - t_i)}{(t_c - t_o)} \right]}$$

Heat Rejection:

$$q = UALMTD = wc_p(t_o - t_i)$$

$$c_p = 4190 \text{ J/kg}\cdot\text{K}$$

$$q = (450)(18) \left\{ \frac{(t_o - 30)}{\ln \left[\frac{(t_c - 30)}{(t_c - t_o)} \right]} \right\} = (3.2)(4190)(t_o - 30)$$

$$\ln \left[\frac{(t_c - 30)}{(t_c - t_o)} \right] = 0.60412$$

$$t_c - 30 = 1.82964 (t_c - t_o)$$

$$t_o = 16.397 + 0.45345 t_c \text{ --- Eq. No. 1}$$

Figure 12-12.

At Heat-rejection ratio = 1.2

Condensing Temperature = 36 C

At Heat-rejection ratio = 1.3

Condensing Temperature = 49 C

$$\text{Heat-rejection ratio} = 0.92308 + 0.0076923 t_c$$

$$q = (0.92308 + 0.0076923 t_c)(55000) = wc_p(t_o - t_i)$$

$$(0.92308 + 0.0076923 t_c)(55000) = (3.2)(4190)(t_o - 30)$$

$$33.7865 + 0.031554 t_c = t_o = 16.397 + 0.45345 t_c$$

$$t_c = 41.22 \text{ C} \text{ --- Ans.}$$

- 12-9. Calculate the mean condensing heat-transfer coefficient when refrigerant 12 condenses on the outside of the horizontal tubes in a shell-and-tube condenser. The outside diameter of the tubes is 19 mm, and in the

vertical rows of tubes there are respectively, two, three, four, three, and two tubes. The refrigerant is condensing at a temperature of 52 C and the temperature of the tubes is 44 C.

Solution:

Condensing Coefficient: Eq. 12-24.

$$h_{\text{cond}} = 0.725 \left(\frac{g\rho^2 h_{\text{fg}} k^3}{\mu \Delta t N D} \right)^{1/4}$$

Table A-5 at 52 C.

$$h_{\text{fg}} = 370.997 - 251.004 \text{ kJ/kg} = 119.993 \text{ kJ/kg}$$

$$h_{\text{fg}} = 199,993 \text{ J/kg}$$

$$\rho = 1 / (0.83179 \text{ L/kg}) = 1202 \text{ kg/m}^3$$

Table 15-5, Liquid Refrigerant 12

$$\mu = 0.000179 \text{ PA.s}$$

$$k = 0.05932 \text{ W/m.K}$$

$$N = (2 + 3 + 4 + 3 + 2) / 5 = 2.8$$

$$\Delta t = 52 \text{ C} - 44 \text{ C} = 8 \text{ K}$$

$$g = 9.81 \text{ m/s}^2$$

$$D = 19 \text{ mm} = 0.019 \text{ m}$$

$$h_{\text{cond}} = 0.725 \left(\frac{(9.81)(1202)^2 (119,993)(0.05932)^3}{(0.000174)(8)(2.8)(0.019)} \right)^{1/4}$$

$$h_{\text{cond}} = 1065 \text{ W/m}^2 \cdot \text{K} \text{ --- Ans.}$$

- 12-10. A condenser manufacturer guarantees the U value under operating conditions to be 990 W/m².K based on the water-side area. In order to allow for fouling of the tubes, what is the U value required when the condenser leaves the factory?

Solution:

$$\frac{1}{U_{o2}} = \frac{1}{U_{o1}} - \frac{A_o}{h_{\text{ff}} A_i}$$

$$U_{o1} = 900 \text{ W/m}^2 \cdot \text{K}$$

$$1/h_{\text{ff}} = 0.000176 \text{ m}^2 \cdot \text{K/W}$$

$$A_o / A_i \sim 1.0$$

$$\frac{1}{U_{o2}} = \frac{1}{900} - 0.000176(1)$$

$$U_{o2} = 1,199 \text{ W/m}^2 \cdot \text{K} \text{ --- Ans.}$$

- 12-11. In example 12-3 the temperature difference between the refrigerant vapor and tube was originally assumed to be 5 K in order to compute the condensing coefficient. Check the validity of this assumption.

Solution:

$$h_{\text{cond}} = 0.725 \left[\frac{(9.81)(1109)^2 (160,900)(0.0779)^3}{(0.000180)\Delta t(3.23)(0.016)} \right]^{1/4}$$

$$h_{\text{cond}} = \frac{2285}{\Delta t^{0.25}}$$

Then,

$$\frac{1}{U_o} = \frac{\Delta t^{0.25}}{2285} + 0.000002735 + \frac{0.016}{0.014} (0.000176) + \frac{0.016}{0.014} \cdot \frac{1}{6910}$$

$$\frac{1}{U_o} = \frac{\Delta t^{0.25}}{2285} + 0.00036927$$

$$U_o = \frac{2285}{\Delta t^{0.25} + 0.843782}$$

$$\text{LMTD} = 12.33 \text{ C}$$

But

$$h_{\text{cond}} \Delta t = U_o \text{LMTD}$$

$$\left(\frac{2285}{\Delta t^{0.25}} \right) \Delta t = \left(\frac{2285}{\Delta t^{0.25} + 0.843782} \right) (12.33)$$

$$\Delta t^{0.75} = \frac{12.33}{\Delta t^{0.25} + 0.843782}$$

$$\Delta t + 0.843782 \Delta t^{0.75} = 12.33$$

$$\Delta t = 8.23 \text{ K}$$

$$\Delta t_{\text{max}} = \text{LMTD} = 12.33 \text{ K}$$

$$\Delta t = \mathbf{8.23 \text{ K to } 12.33 \text{ K} \dots \text{Ans.}}$$

- 12-12. (a) A Wilson plot is to be constructed for a finned air-cooled condenser by varying the rate of airflow. What should the abscissa of the plot be?
 (b) A Wilson plot is to be constructed for a shell-and-tube water chiller in which refrigerant evaporates in tubes. The rate of water flow is to be varied for the Wilson plot. What should the abscissa of the plot be?

Solution:

(a) Eq. 12-20.

$$\frac{1}{U_o A_o} = \frac{1}{h_f (A_p + \eta A_e)} + \frac{x}{k A_m} + \frac{1}{h_i A_i}$$

Eq. 12-21

$$h_f = 38V^{0.5}$$

V in m/s.

Varying airflow, the Wilson plot is a graph of $1/U_o$ versus $1/V^{0.5}$.

Abscissa is $1/V^{0.5}$ where V is the face velocity in meters per second.

(b) Eq. 12-27

$$\frac{1}{U_o A_o} = \frac{1}{h_o} + \frac{x}{k A_m} + \frac{1}{h_i A_i}$$

Liquid in shell, variation of Eq. 12-13,

$$h_o = (\text{const})V^{0.6}$$

Varying water flow, the Wilson plot is a graph of $1/U_o$ versus $1/V^{0.6}$.

Abscissa is $1/V^{0.6}$ where V is the face velocity in meters per second.

- 12-13. The following values were measured on an ammonia condenser.

U _o , W/sq m.K	2300	2070	1930	1760	1570	1360	1130	865
V, m/s	1.22	0.975	0.853	0.731	0.61	0.488	0.366	0.244

Water flowed inside the tubes, and the tubes were 51 mm OD and 46 mm ID and had a conductivity of 60 W/m.K. Using a Wilson plot, determine the condensing coefficient.

Solution:

Wilson plot

$$\frac{1}{U_o} = C_1 + \frac{C_2}{V^{0.8}}$$

Tabulation:

$1/U_o$	$1/V^{0.8}$
0.000434783	0.852928
0.000483092	1.020461
0.000518135	1.13564
0.000568182	1.28489
0.000636943	1.485033
0.000735294	1.775269
0.000884956	2.234679
0.001156069	3.090923

By linear regression:

$$C_1 = 0.000153033$$

$$C_2 = 0.000325563$$

But:

$$C_1 = \frac{1}{h_o} + \frac{x A_o}{k A_m}$$

$$\frac{A_o}{A_m} = \frac{51}{(51+46)/2} = 1.05155$$

$$x = (1/2)(51 - 46) = 2.5 \text{ mm} = 0.0025 \text{ m}$$

$$k = 60 \text{ W/m.K}$$

$$0.000153033 = \frac{1}{h_o} + \frac{(0.0025)(1.05155)}{60}$$

$$h_o = 9,156 \text{ W/m}^2 \cdot \text{K} \text{ --- Ans.}$$

12-14. Develop Eq. (12-23) from Eq. (12-22).

Solution: Eq. 12-22.

$$\frac{h_{cv} x}{k} = \left[\frac{g \rho^2 h_{fg} x^3}{4 \mu k \Delta t} \right]^{1/4}$$

$$\bar{h}_{cv} = \frac{\int_0^L h_{cv} dx}{L}$$

$$\bar{h}_{cv} = \frac{\int_0^L \frac{k}{x} \left[\frac{g\rho^2 h_{fg} x^3}{4\mu k \Delta t} \right]^{1/4} dx}{L}$$

$$\bar{h}_{cv} = \left(\frac{k}{L} \right) \left[\frac{g\rho^2 h_{fg}}{4\mu k \Delta t} \right]^{1/4} \int_0^L x^{-1/4} dx$$

$$\bar{h}_{cv} = \left(\frac{k}{L} \right) \left[\frac{g\rho^2 h_{fg}}{4\mu k \Delta t} \right]^{1/4} \left(\frac{4}{3} \right) \left[x^{3/4} \right]_0^L$$

$$\bar{h}_{cv} = \left(\frac{k}{L} \right) \left[\frac{g\rho^2 h_{fg}}{4\mu k \Delta t} \right]^{1/4} \left(\frac{4}{3} \right) L^{3/4}$$

$$\bar{h}_{cv} = \left(\frac{1}{4} \right)^{1/4} \left(\frac{4}{3} \right) \left[\frac{g\rho^2 h_{fg} k^3}{\mu k \Delta t L} \right]^{1/4}$$

Ans. Eq. 12-23.

$$\bar{h}_{cv} = 0.943 \left[\frac{g\rho^2 h_{fg} k^3}{\mu k \Delta t L} \right]^{1/4}$$

12-15. From Fig. 12-21, determine C and b in the equation $h = C\Delta t^b$ applicable to values in the middle of the typical range.

Solution: Use Fig. 12-21

Tabulation:

Heat-transfer Coefficient W/m ² .K, h	Heat flux W/m ²	Δt K
400	710	1.775
600	1550	2.583
800	2820	3.525
1000	4170	4.170
1500	9000	6.000

$$h = C\Delta t^b$$

By Curve-Fitting:

$$C = 212.8$$

$$b = 1.08$$

$$h = 212.8\Delta t^{1.08} \text{ --- Ans.}$$

13-16. Section 12-18 makes the statement that on a graph of the performance of a water chilling evaporator with the coordinates of Fig. 12-23, a curve for a given entering water temperature is a straight line if the heat-transfer

coefficients are constant. prove this statement.

Solution: Use Fig. 12-23.

t_e = evaporating temperature

t_a = entering-water temperature (constant)

U = heat-transfer coefficient (constant)

$$q = wc_p(t_b - t_a) = UA \left(\frac{t_a + t_b}{2} - t_e \right)$$

$$wc_p t_b - wc_p t_a = 0.5UA t_a + 0.5UA t_b - UA t_e$$

$$t_b = \frac{(wc_p + 0.5UA)t_a - UA t_e}{(wc_p - 0.5UA)}$$

$$q = wc_p \left[\frac{(wc_p + 0.5UA)t_a - UA t_e}{(wc_p - 0.5UA)} - t_a \right]$$

$$q = wc_p \left[\frac{(wc_p + 0.5UA)t_a - UA t_e - (wc_p - 0.5UA)t_a}{(wc_p - 0.5UA)} \right]$$

$$q = wc_p \left[\frac{UA t_a - UA t_e}{(wc_p - 0.5UA)} \right]$$

$$q = \frac{wc_p UA}{wc_p - 0.5UA} (t_a - t_e)$$

If U is constant.

$$q = (\text{constant})(t_a - t_e)$$

At constant t_e , this is a straight line. - - - Ans.

- 0 0 0 -

- 13-1. Using the method described in Sec. 13-5 and entering conditions given in Table 13-1 for example 13-1 at position 4, compute the length of tube needed to drop the temperature to 36 C. Use property values from Refrigerant 22 tables when possible.

Solution:

At Table 13-1, position 4

Temperature = 37 C.

$$p_4 = 1425.8 \text{ kPa}$$

$$x_4 = 0.023$$

$$v_4 = 0.001230 \text{ m}^3/\text{kg}$$

$$h_4 = 249.84 \text{ kJ/kg}$$

$$V_4 = 5.895 \text{ m/s}$$

At Position 5, $t = 36 \text{ C}$

Eq. 13-15

$$\ln\left(\frac{p}{1000}\right) = 15.06 - \frac{2418.4}{t + 273.15}$$

$$\ln\left(\frac{p_5}{1000}\right) = 15.06 - \frac{2418.4}{36 + 273.15}$$

$$p_5 = 1390.3 \text{ kPa}$$

Eq. 13-16.

$$v_{f5} = 0.777 + 0.002062t + 0.00001608t^2$$

$$v_{f5} = \frac{0.777 + 0.002062(36) + 0.00001608(36)^2}{1000}$$

$$n_{f5} = 0.000872 \text{ m}^3/\text{kg}$$

Eq. 13-17.

$$v_{g5} = \frac{-4.26 + 94050(t + 273.15)/p}{1000}$$

$$v_{g5} = \frac{-4.26 + 94050(36 + 273.15)/(1390300)}{1000}$$

$$n_{g5} = 0.01665 \text{ m}^3/\text{kg}$$

Eq. 13-18.

$$h_{f5} = 200.0 + 1.172t + 0.001854t^2$$

$$h_{f5} = 200.0 + 1.172(36) + 0.001854(36)^2$$

$$h_{f5} = 244.6 \text{ kJ/kg}$$

Eq. 13-19

$$h_{g5} = 405.5 + 0.3636t - 0.002273t^2$$

$$h_{g5} = 405.5 + 0.3636(36) - 0.002273(36)^2$$

$$h_{g5} = 415.64 \text{ kJ/kg}$$

Eq. 13-20

$$\mu_{f5} = 0.0002367 - 1.715 \times 10^{-6}t + 8.869 \times 10^{-9}t^2$$

$$\mu_{f5} = 0.0002367 - 1.715 \times 10^{-6}(36) + 8.869 \times 10^{-9}(36)^2$$

$$\mu_{f5} = 0.0001865 \text{ Pa.s}$$

Eq. 13-21.

$$\mu_{g5} = 11.945 \times 10^{-6} + 50.06 \times 10^{-9}t + 0.2560 \times 10^{-9}t^2$$

$$\mu_{g5} = 11.945 \times 10^{-6} + 50.06 \times 10^{-9} (36) + 0.2560 \times 10^{-9} (36)^2$$

$$\mu_{g5} = 0.00001408 \text{ Pa.s}$$

Eq. 13-14.

$$x = \frac{-b \pm \sqrt{b^2 - 4ac}}{2a}$$

$$a = (v_{g5} - v_{f5})^2 \left(\frac{w}{A} \right)^2 \frac{1}{2}$$

$w/A = 4792.2 \text{ kg/s.m}^2$ from Ex. 13-1.

$$a = (0.01665 - 0.000872)^2 (4792.2)^2 \frac{1}{2} = 2858.54$$

$$b = 1000(h_{g5} - h_{f5}) + v_{f5} (v_{g5} - v_{f5}) \left(\frac{w}{A} \right)^2$$

$$b = 1000(415.64 - 244.6) + 0.00872(0.01665 - 0.000872)(4792.2)^2$$

$$b = 171,356$$

$$c = 1000(h_{f5} - h_4) + \left(\frac{w}{A} \right)^2 \frac{1}{2} v_{f5}^2 - \frac{V_4^2}{2}$$

$$c = 1000(244.6 - 249.84) + (4792.2)^2 \frac{1}{2} (0.000872)^2 - \frac{(5.895)^2}{2}$$

$$c = -5,248.65$$

$$x = \frac{-b \pm \sqrt{b^2 - 4ac}}{2a}$$

$$x = \frac{-171,356 \pm \sqrt{171,356^2 - 4(2858.54)(-5248.65)}}{2(2858.54)} = 0.031$$

Then:

$$h_5 = h_{f5} + x(h_{g5} - h_{f5})$$

$$h_5 = 244.6 + 0.031(415.64 - 244.6)$$

$$h_5 = 249.9 \text{ kJ/kg}$$

$$v_5 = v_{f5} + x(v_{g5} - v_{f5})$$

$$v_5 = 0.000873 + 0.031(0.01665 - 0.000872)$$

$$v_5 = 0.001361 \text{ m}^3/\text{kg}$$

$$\mu_5 = \mu_{f5} + x(\mu_{g5} - \mu_{f5})$$

$$\mu_5 = 0.0001865 + 0.031(0.00001408 - 0.0001865)$$

$$\mu_5 = 0.0001812 \text{ Pa.s}$$

$$V_5 = \frac{w}{A} v_5 = (4792.2)(0.001361)$$

$$V_5 = 6.522 \text{ m/s}$$

$$Re = \frac{VD}{\mu v} = \frac{D}{\mu} \left(\frac{w}{A} \right)$$

$$D = 1.63 \text{ mm} = 0.00163 \text{ m}$$

At 4:

$$\mu_4 = \mu_{f4} = 0.0002367 - 1.715 \times 10^{-6} t + 8.869 \times 10^{-9} t^2$$

$$t_4 = 37 \text{ C}$$

$$\mu_4 = 0.0002367 - 1.715 \times 10^{-6} (37) + 8.869 \times 10^{-9} (37)^2$$

$$\mu_4 = 0.0001854$$

$$\text{Re} = \frac{(0.00163)}{(0.0001812)} (4792.2) = 43,109$$

Eq. 13-9.

$$f = \frac{0.33}{\text{Re}^{0.25}}$$

$$f_4 = \frac{0.33}{(42,132)^{0.25}} = 0.02303$$

$$f_5 = \frac{0.33}{(43,109)^{0.25}} = 0.02290$$

$$f_m = \frac{0.02303 + 0.02290}{2} = 0.022965$$

$$V_m = \frac{5.895 + 6.522}{2} = 6.2085 \text{ m/s}$$

Eq. 13-4

$$\left[(p_4 - p_5) - f \frac{\Delta L}{D} \frac{V^2}{2v} \right] A = w(V_5 - V_4)$$

Eq. 13-7

$$f \frac{\Delta L}{D} \frac{V^2}{2v} = f \frac{\Delta L}{D} \frac{V}{2} \frac{w}{A}$$

$$(p_4 - p_5) - f \frac{\Delta L}{D} \frac{V}{2} \frac{w}{A} = \frac{w}{A} (V_5 - V_4)$$

$$1000(1425.8 - 1390.3) - f \frac{\Delta L}{D} \frac{V}{2} \frac{w}{A} = 4792.2(6.522 - 5.895)$$

$$f \frac{\Delta L}{D} \frac{V}{2} \frac{w}{A} = 32,495.3$$

$$(0.022965) \frac{\Delta L}{(0.00163)} \frac{(6.2085)}{2} (4792.2) = 32,495.3$$

$$\Delta L_{4-5} = 0.155 \text{ m} \text{ --- Ans.}$$

13-2. A capillary tube is to be selected to throttle 0.011 kg/s of refrigerant 12 from a condensing pressure of 960 kPa and a temperature of 35 C to an evaporator operating at -20 C.

- Using Figs. 13-7 and 13-8, select the bore and length of a capillary tube for this assignment.
- If the evaporating temperature had been 5 C rather than -20 C, would the selection of part (a) be suitable? Discuss assumptions that have been made.

Solution: Table A-5, $p = 960 \text{ kPa}$, $t_{\text{sat}} = 40 \text{ C}$,

Subcooling = $40 \text{ C} - 35 \text{ C} = 5 \text{ C}$

- Use bore diameter $D = 1.63 \text{ mm}$
Fig. 13-7, 960 kPa inlet pressure, saturated.
Flow rate = 0.0089 kg/s
Fig. 13-8.
Flow correction factor = $(0.011 \text{ kg/s}) / (0.0089 \text{ kg/s})$
Flow correction factor = 1.24
Then Length = 1,230 mm = **1.23 m L --- Ans.**
- Use positions from 35 C to -20 C at 5 C increment.
Table A-5, 35 C, sat. $p = 847.72 \text{ kPa}$.

At position 1,

$$h_1 = 233.50 \text{ kJ/kg}$$

$$v_1 = 0.78556 \text{ L/kg} = 0.000786 \text{ m}^3/\text{kg}$$

Table 15-5, $\mu_1 = 0.000202 \text{ Pa}\cdot\text{s}$

$$p_1 = 960 \text{ kPa}$$

$$\frac{w}{A} = \frac{0.011}{\pi(0.00163)^2/4} = 5271.4 \text{ kg/s}\cdot\text{m}^2$$

$$V_1 = \frac{w}{A} v_1 = (5271.4)(0.000786)$$

$$V_1 = 4.143 \text{ m/s}$$

$$\text{Re}_1 = \frac{V_1 D}{\mu_1 v_1} = \left(\frac{w}{A} \right) \left(\frac{D}{\mu_1} \right)$$

$$\text{Re}_1 = \frac{(5271.4)(0.00163)}{0.000202} = 42,537$$

$$f_1 = \frac{0.33}{\text{Re}_1^{0.25}} = \frac{0.33}{(42537)^{0.25}} = 0.02298$$

At position 2, 30 C

$$p_2 = 744.90 \text{ kPa}$$

$$h_{f2} = 228.54 \text{ kJ/kg}$$

$$h_{g2} = 363.57 \text{ kJ/kg}$$

$$v_{f2} = 0.77386 \text{ L/kg} = 0.000774 \text{ m}^3/\text{kg}$$

$$v_{g2} = 23.5082 \text{ L/kg} = 0.02351 \text{ m}^3/\text{kg}$$

$$\mu_{f2} = 0.0002095 \text{ Pa}\cdot\text{s}$$

$$\mu_{g2} = 0.00001305 \text{ Pa}\cdot\text{s}$$

$$x = \frac{-b \pm \sqrt{b^2 - 4ac}}{2a}$$

$$a = (v_{g2} - v_{f2})^2 \left(\frac{w}{A} \right)^2 \frac{1}{2}$$

$$a = (0.02351 - 0.000774)^2 (5271.4)^2 \frac{1}{2} = 7182.1$$

$$b = 1000(h_{g2} - h_{f2}) + v_{f2} (v_{g2} - v_{f2}) \left(\frac{w}{A} \right)^2$$

$$b = 1000(363.57 - 228.54) + 0.000774(0.02351 - 0.000774)(5271.4)^2$$

$$b = 135,519$$

$$c = 1000(h_{f2} - h_1) + \left(\frac{w}{A} \right)^2 \frac{1}{2} v_{f2}^2 - \frac{V_1^2}{2}$$

$$c = 1000(228.54 - 233.50) + (5271.4)^2 \frac{1}{2} (0.000774)^2 - \frac{(4.143)^2}{2}$$

$$c = -4,960.3$$

$$x = \frac{-b \pm \sqrt{b^2 - 4ac}}{2a}$$

$$x = \frac{-135,519 \pm \sqrt{135,519^2 - 4(7182.1)(-4960.3)}}{2(7182.1)} = 0.0365$$

Then:

$$h_2 = h_{f2} + x(h_{g2} - h_{f2})$$

$$h_2 = 233.47 \text{ kJ/kg}$$

$$v_2 = v_{f2} + x(v_{g2} - v_{f2})$$

$$v_2 = 0.001604 \text{ m}^3/\text{kg}$$

$$\mu_2 = \mu_{f2} + x(\mu_{g2} - \mu_{f2})$$

$$\mu_2 = 0.0002023 \text{ Pa}\cdot\text{s}$$

$$V_2 = \frac{w}{A} v_2 = (5271.4)(0.001604)$$

$$V_2 = 8.455 \text{ m/s}$$

$$\text{Re}_2 = \frac{VD}{\mu v} = \frac{D}{\mu_2} \left(\frac{w}{A} \right)$$

$$\text{Re}_2 = \frac{(5271.4)(0.00163)}{0.0002023} = 42,474$$

$$f_2 = \frac{0.33}{\text{Re}^{0.25}}$$

$$f_2 = \frac{0.33}{(42,474)^{0.25}} = 0.02299$$

$$f_m = \frac{0.02298 + 0.02299}{2} = 0.022985$$

$$V_m = \frac{4.142 + 8.455}{2} = 6.299 \text{ m/s}$$

$$(p_1 - p_2) - f \frac{\Delta L}{D} \frac{V}{2} \frac{w}{A} = \frac{w}{A} (V_2 - V_1)$$

$$1000(960 - 744.9) - (0.022985) \frac{\Delta L}{(0.00163)} \frac{(6.299)}{2} (5271.4) = 5271.4(8.455 - 4.143)$$

$$\Delta L_{1-2} = 0.8217 \text{ m}$$

At position 3, 25 C

$$p_2 = 651.62 \text{ kPa}$$

$$h_{f2} = 223.65 \text{ kJ/kg}$$

$$h_{g2} = 361.68 \text{ kJ/kg}$$

$$v_{f2} = 0.76286 \text{ L/kg} = 0.000763 \text{ m}^3/\text{kg}$$

$$v_{g2} = 26.8542 \text{ L/kg} = 0.026854 \text{ m}^3/\text{kg}$$

$$\mu_{f2} = 0.000217 \text{ Pa}\cdot\text{s}$$

$$\mu_{g2} = 0.0000128 \text{ Pa}\cdot\text{s}$$

$$x = \frac{-b \pm \sqrt{b^2 - 4ac}}{2a}$$

$$a = (v_{g3} - v_{f3})^2 \left(\frac{w}{A} \right)^2 \frac{1}{2}$$

$$a = (0.026854 - 0.000763)^2 (5271.4)^2 \frac{1}{2} = 9458.1$$

$$b = 1000(h_{g3} - h_{f3}) + v_{f3}(v_{g3} - v_{f3}) \left(\frac{w}{A}\right)^2$$

$$b = 1000(361.68 - 223.65) + 0.000763(0.026854 - 0.000763)(5271.4)^2$$

$$b = 138,583$$

$$c = 1000(h_{f3} - h_2) + \left(\frac{w}{A}\right)^2 \frac{1}{2} v_{f3}^2 - \frac{V_2^2}{2}$$

$$c = 1000(223.65 - 233.47) + (5271.4)^2 \frac{1}{2} (0.000763)^2 - \frac{(8.455)^2}{2}$$

$$c = -9,847.7$$

$$x = \frac{-b \pm \sqrt{b^2 - 4ac}}{2a}$$

$$x = \frac{-138,583 \pm \sqrt{138,583^2 - 4(9458.1)(-9847.7)}}{2(9458.1)} = 0.0707$$

Then:

$$h_3 = h_{f3} + x(h_{g3} - h_{f3})$$

$$h_3 = 233.41 \text{ kJ/kg}$$

$$v_3 = v_{f3} + x(v_{g3} - v_{f3})$$

$$v_3 = 0.002608 \text{ m}^3/\text{kg}$$

$$\mu_3 = \mu_{f3} + x(\mu_{g3} - \mu_{f3})$$

$$\mu_3 = 0.0002026 \text{ Pa}\cdot\text{s}$$

$$V_3 = \frac{w}{A} v_3 = (5271.4)(0.002608)$$

$$V_3 = 13.748 \text{ m/s}$$

$$Re_3 = \frac{VD}{\mu v} = \frac{D}{\mu_3} \left(\frac{w}{A}\right)$$

$$Re_3 = \frac{(5271.4)(0.00163)}{0.0002026} = 42,411$$

$$f_3 = \frac{0.33}{Re^{0.25}}$$

$$f_3 = \frac{0.33}{(42,411)^{0.25}} = 0.0230$$

$$f_m = \frac{0.02299 + 0.0230}{2} = 0.0230$$

$$V_m = \frac{8.455 + 13.748}{2} = 11.102 \text{ m/s}$$

$$(p_2 - p_3) - f \frac{\Delta L}{D} \frac{V}{2} \frac{w}{A} = \frac{w}{A} (V_3 - V_2)$$

$$1000(744.9 - 651.62) - (0.0230) \frac{\Delta L}{(0.00163)} \frac{(11.102)}{2} (5271.4) = 5271.4(13.748 - 8.455)$$

$$\Delta L_{2-3} = 0.1584 \text{ m}$$

At position 4, 20 C

$$p_4 = 567.29 \text{ kPa}$$

$$h_{f4} = 218.82 \text{ kJ/kg}$$

$$h_{g4} = 359.73 \text{ kJ/kg}$$

$$v_{f4} = 0.75246 \text{ L/kg} = 0.00075246 \text{ m}^3/\text{kg}$$

$$v_{g4} = 30.7802 \text{ L/kg} = 0.0307802 \text{ m}^3/\text{kg}$$

$$\mu_{f2} = 0.000225 \text{ Pa}\cdot\text{s}$$

$$\mu_{g2} = 0.0000126 \text{ Pa}\cdot\text{s}$$

$$x = \frac{-b \pm \sqrt{b^2 - 4ac}}{2a}$$

$$a = (v_{g4} - v_{f4})^2 \left(\frac{w}{A} \right)^2 \frac{1}{2}$$

$$a = (0.0307802 - 0.00075246)^2 (5271.4)^2 \frac{1}{2} = 12,528$$

$$b = 1000(h_{g4} - h_{f4}) + v_{f4} (v_{g4} - v_{f4}) \left(\frac{w}{A} \right)^2$$

$$b = 1000(359.73 - 218.82) + 0.00075246(0.0307802 - 0.00075246)(5271.4)^2$$

$$b = 141,538$$

$$c = 1000(h_{f4} - h_3) + \left(\frac{w}{A} \right)^2 \frac{1}{2} v_{f4}^2 - \frac{V_3^2}{2}$$

$$c = 1000(218.82 - 233.41) + (5271.4)^2 \frac{1}{2} (0.00075246)^2 - \frac{(13.748)^2}{2}$$

$$c = -14,677$$

$$x = \frac{-b \pm \sqrt{b^2 - 4ac}}{2a}$$

$$x = \frac{-141,538 \pm \sqrt{141,538^2 - 4(12528)(-14677)}}{2(12528)} = 0.1028$$

Then:

$$h_4 = h_{f4} + x(h_{g4} - h_{f4})$$

$$h_4 = 233.31 \text{ kJ/kg}$$

$$v_4 = v_{f4} + x(v_{g4} - v_{f4})$$

$$v_4 = 0.003839 \text{ m}^3/\text{kg}$$

$$\mu_4 = \mu_{f4} + x(\mu_{g4} - \mu_{f4})$$

$$\mu_4 = 0.0002032 \text{ Pa}\cdot\text{s}$$

$$V_4 = \frac{w}{A} v_4 = (5271.4)(0.003839)$$

$$V_4 = 20.237 \text{ m/s}$$

$$Re_4 = \frac{VD}{\mu v} = \frac{D}{\mu_4} \left(\frac{w}{A} \right)$$

$$Re_4 = \frac{(5271.4)(0.00163)}{0.0002032} = 42,285$$

$$f_4 = \frac{0.33}{\text{Re}^{0.25}}$$

$$f_4 = \frac{0.33}{(42,285)^{0.25}} = 0.0230$$

$$f_m = \frac{0.0230 + 0.0230}{2} = 0.0230$$

$$V_m = \frac{13.748 + 20.237}{2} = 16.993 \text{ m/s}$$

$$(p_4 - p_3) - f \frac{\Delta L}{D} \frac{V}{2} \frac{w}{A} = \frac{w}{A} (V_4 - V_3)$$

$$1000(651.62 - 567.29) - (0.0230) \frac{\Delta L}{(0.00163)} \frac{(16.993)}{2} (5271.4) = 5271.4(20.237 - 13.748)$$

$$\Delta L_{3-4} = 0.0793 \text{ m}$$

At position 5, 15 C

$$p_5 = 491.37 \text{ kPa}$$

$$h_{f5} = 214.05 \text{ kJ/kg}$$

$$h_{g5} = 357.73 \text{ kJ/kg}$$

$$v_{f5} = 0.74262 \text{ L/kg} = 0.00074262 \text{ m}^3/\text{kg}$$

$$v_{g5} = 35.4133 \text{ L/kg} = 0.0354133 \text{ m}^3/\text{kg}$$

$$\mu_{f5} = 0.0002355 \text{ Pa}\cdot\text{s}$$

$$\mu_{g5} = 0.0000124 \text{ Pa}\cdot\text{s}$$

$$x = \frac{-b \pm \sqrt{b^2 - 4ac}}{2a}$$

$$a = (v_{g5} - v_{f5})^2 \left(\frac{w}{A} \right)^2 \frac{1}{2}$$

$$a = (0.0354133 - 0.00074262)^2 (5271.4)^2 \frac{1}{2} = 16,701$$

$$b = 1000(h_{g5} - h_{f5}) + v_{f5} (v_{g5} - v_{f5}) \left(\frac{w}{A} \right)^2$$

$$b = 1000(357.73 - 214.05) + 0.00074262(0.0354133 - 0.00074262)(5271.4)^2$$

$$b = 144,396$$

$$c = 1000(h_{f5} - h_4) + \left(\frac{w}{A} \right)^2 \frac{1}{2} v_{f5}^2 - \frac{V_4^2}{2}$$

$$c = 1000(214.05 - 233.31) + (5271.4)^2 \frac{1}{2} (0.00074262)^2 - \frac{(20.237)^2}{2}$$

$$c = -19,457$$

$$x = \frac{-b \pm \sqrt{b^2 - 4ac}}{2a}$$

$$x = \frac{-144,396 \pm \sqrt{144,396^2 - 4(16,701)(-19,457)}}{2(16,701)} = 0.1327$$

Then:

$$h_5 = h_{f5} + x(h_{g5} - h_{f5})$$

$$h_5 = 233.12 \text{ kJ/kg}$$

$$v_5 = v_{f5} + x(v_{g5} - v_{f5})$$

$$v_5 = 0.005343 \text{ m}^3/\text{kg}$$

$$\mu_5 = \mu_{f5} + x(\mu_{g5} - \mu_{f5})$$

$$\mu_5 = 0.0002059 \text{ Pa}\cdot\text{s}$$

$$V_5 = \frac{W}{A} v_5 = (5271.4)(0.005343)$$

$$V_5 = 28.165 \text{ m/s}$$

$$Re_5 = \frac{VD}{\mu v} = \frac{D}{\mu_5} \left(\frac{w}{A} \right)$$

$$Re_5 = \frac{(5271.4)(0.00163)}{0.0002059} = 41,731$$

$$f_5 = \frac{0.33}{Re^{0.25}}$$

$$f_5 = \frac{0.33}{(41,731)^{0.25}} = 0.02309$$

$$f_m = \frac{0.0230 + 0.02309}{2} = 0.02305$$

$$V_m = \frac{20.237 + 28.165}{2} = 24.201 \text{ m/s}$$

$$(p_4 - p_5) - f \frac{\Delta L}{D} \frac{V}{2} \frac{w}{A} = \frac{w}{A} (V_5 - V_4)$$

$$1000(567.29 - 491.37) - (0.02305) \frac{\Delta L}{(0.00163)} \frac{(24.201)}{2} (5271.4) = 5271.4(28.165 - 20.237)$$

$$\Delta L_{4-5} = 0.0378 \text{ m}$$

At position 6, 10 C

$$p_6 = 423.30 \text{ kPa}$$

$$h_{f6} = 209.32 \text{ kJ/kg}$$

$$h_{g6} = 355.69 \text{ kJ/kg}$$

$$v_{f6} = 0.73326 \text{ L/kg} = 0.00073326 \text{ m}^3/\text{kg}$$

$$v_{g6} = 40.9137 \text{ L/kg} = 0.0409137 \text{ m}^3/\text{kg}$$

$$\mu_{f6} = 0.000246 \text{ Pa}\cdot\text{s}$$

$$\mu_{g6} = 0.0000122 \text{ Pa}\cdot\text{s}$$

$$x = \frac{-b \pm \sqrt{b^2 - 4ac}}{2a}$$

$$a = (v_{g6} - v_{f6})^2 \left(\frac{w}{A} \right)^2 \frac{1}{2}$$

$$a = (0.0409137 - 0.00073326)^2 (5271.4)^2 \frac{1}{2} = 22,431$$

$$b = 1000(h_{g6} - h_{f6}) + v_{f6} (v_{g6} - v_{f6}) \left(\frac{w}{A} \right)^2$$

$$b = 1000(355.69 - 209.32) + 0.00073326(0.0409137 - 0.00073326)(5271.4)^2$$

$$b = 147,189$$

$$c = 1000(h_{f6} - h_5) + \left(\frac{w}{A}\right)^2 \frac{1}{2} v_{f6}^2 - \frac{V_5^2}{2}$$

$$c = 1000(209.32 - 233.12) + (5271.4)^2 \frac{1}{2} (0.00073326)^2 - \frac{(28.165)^2}{2}$$

$$c = -24,189$$

$$x = \frac{-b \pm \sqrt{b^2 - 4ac}}{2a}$$

$$x = \frac{-147,189 \pm \sqrt{147,189^2 - 4(22,431)(-24,189)}}{2(22,431)} = 0.1604$$

Then:

$$h_6 = h_{f6} + x(h_{g6} - h_{f6})$$

$$h_6 = 232.80 \text{ kJ/kg}$$

$$v_6 = v_{f6} + x(v_{g6} - v_{f6})$$

$$v_6 = 0.007178 \text{ m}^3/\text{kg}$$

$$\mu_6 = \mu_{f6} + x(\mu_{g6} - \mu_{f6})$$

$$\mu_6 = 0.0002085 \text{ Pa}\cdot\text{s}$$

$$V_6 = \frac{w}{A} v_6 = (5271.4)(0.007178)$$

$$V_6 = 37.838 \text{ m/s}$$

$$Re_6 = \frac{VD}{\mu v} = \frac{D}{\mu_6} \left(\frac{w}{A}\right)$$

$$Re_6 = \frac{(5271.4)(0.00163)}{0.0002085} = 41,211$$

$$f_6 = \frac{0.33}{Re^{0.25}}$$

$$f_6 = \frac{0.33}{(41,211)^{0.25}} = 0.02316$$

$$f_m = \frac{0.02309 + 0.02316}{2} = 0.02313$$

$$V_m = \frac{28.165 + 37.838}{2} = 33 \text{ m/s}$$

$$(p_5 - p_6) - f \frac{\Delta L}{D} \frac{V}{2} \frac{w}{A} = \frac{w}{A} (V_6 - V_5)$$

$$1000(491.37 - 423.30) - (0.02313) \frac{\Delta L}{(0.00163)} \frac{(33.0)}{2} (5271.4) = 5271.4(37.838 - 28.165)$$

$$\Delta L_{5-6} = 0.0138 \text{ m}$$

At position 7, 5 C

$$p_7 = 363.55 \text{ kPa}$$

$$h_{f7} = 204.64 \text{ kJ/kg}$$

$$h_{g7} = 353.60 \text{ kJ/kg}$$

$$v_{f7} = 0.72438 \text{ L/kg} = 0.00072438 \text{ m}^3/\text{kg}$$

$$v_{g7} = 47.4853 \text{ L/kg} = 0.0474853 \text{ m}^3/\text{kg}$$

$$\mu_{f6} = 0.0002565 \text{ Pa}\cdot\text{s}$$

$$\mu_{g6} = 0.0000120 \text{ Pa}\cdot\text{s}$$

$$x = \frac{-b \pm \sqrt{b^2 - 4ac}}{2a}$$

$$a = (v_{g7} - v_{f7})^2 \left(\frac{w}{A}\right)^2 \frac{1}{2}$$

$$a = (0.0474853 - 0.00072438)^2 (5271.4)^2 \frac{1}{2} = 30,380$$

$$b = 1000(h_{g7} - h_{f7}) + v_{f7}(v_{g7} - v_{f7}) \left(\frac{w}{A}\right)^2$$

$$b = 1000(353.60 - 204.64) + 0.00072438(0.0474853 - 0.00072438)(5271.4)^2$$

$$b = 149,901$$

$$c = 1000(h_{f7} - h_6) + \left(\frac{w}{A}\right)^2 \frac{1}{2} v_{f7}^2 - \frac{V_6^2}{2}$$

$$c = 1000(204.64 - 232.80) + (5271.4)^2 \frac{1}{2} (0.00072438)^2 - \frac{(37.838)^2}{2}$$

$$c = -28,869$$

$$x = \frac{-b \pm \sqrt{b^2 - 4ac}}{2a}$$

$$x = \frac{-149,901 \pm \sqrt{149,901^2 - 4(30,380)(-28,869)}}{2(30,380)} = 0.1856$$

Then:

$$h_7 = h_{f7} + x(h_{g7} - h_{f7})$$

$$h_7 = 232.29 \text{ kJ/kg}$$

$$v_7 = v_{f7} + x(v_{g7} - v_{f7})$$

$$v_7 = 0.009403 \text{ m}^3/\text{kg}$$

$$\mu_7 = \mu_{f7} + x(\mu_{g7} - \mu_{f7})$$

$$\mu_7 = 0.0002111 \text{ Pa}\cdot\text{s}$$

$$V_7 = \frac{w}{A} v_7 = (5271.4)(0.009403)$$

$$V_6 = 49.567 \text{ m/s}$$

$$\text{Re}_7 = \frac{VD}{\mu v} = \frac{D}{\mu_7} \left(\frac{w}{A}\right)$$

$$\text{Re}_7 = \frac{(5271.4)(0.00163)}{0.0002111} = 40,703$$

$$f_7 = \frac{0.33}{\text{Re}^{0.25}}$$

$$f_7 = \frac{0.33}{(40,703)^{0.25}} = 0.02323$$

$$f_m = \frac{0.02316 + 0.02323}{2} = 0.02320$$

$$V_m = \frac{37.838 + 49.567}{2} = 43.703 \text{ m/s}$$

$$(p_6 - p_7) - f \frac{\Delta L}{D} \frac{V}{2} \frac{w}{A} = \frac{w}{A} (V_7 - V_6)$$

$$1000(423.3 - 363.55) - (0.02320) \frac{\Delta L}{(0.00163)} \frac{(43.703)}{2} (5271.4) = 5271.4(49.567 - 37.838)$$

$$\Delta L_{6-7} = -0.0013 \text{ m} \sim 0.000 \text{ m}$$

Assume choked flow is at approximately 5 C.

$$L = \Delta L_{1-2} + \Delta L_{2-3} + \Delta L_{3-4} + \Delta L_{4-5} + \Delta L_{5-6} + \Delta L_{6-7}$$

$$L = 0.8217 \text{ m} + 0.1584 \text{ m} + 0.0793 \text{ m} + 0.0378 \text{ m} + 0.0138 \text{ m} + 0 \text{ m}$$

$$L = 1.111 \text{ m}$$

Ans. By assuming choked flow length the same , choked flow is at 5 C. 5 C is still suitable for the selection of part (a) as it is the choked flow temperature.

13-3. A refrigerant 22 refrigerating system operates with a condensing temperature of 35 C and an evaporating temperature of -10 C. If the vapor leaves the evaporator saturated and is compressed isentropically, what is the COP of the cycle (a) if saturated liquid enters the expansion device and (b) if the refrigerant entering the expansion device is 10 percent vapor as in Fig. 13-3?

Solution: Table A-6.

At 1, -10 C, $h_1 = 401.555 \text{ kJ/kg}$

$$s_1 = 1.76713 \text{ kJ/kg}$$

At 2, 35 C, constant entropy, Table A-7

$$h_2 = 435.212 \text{ kJ/kg}$$

(a) At 35 C saturated.

$$h_3 = h_f = 243.114 \text{ kJ/kg}$$

$$h_4 = h_3 = 243.114 \text{ kJ/kg}$$

$$\text{COP} = \frac{h_1 - h_4}{h_2 - h_1} = \frac{401.555 - 243.114}{435.212 - 401.555}$$

COP = 4.71 - - - Ans.

(b) $h_3 = h_f + x (h_g - h_f)$

$$h_f = 243.114 \text{ kJ/kg}$$

$$h_g = 415.627 \text{ kJ/kg}$$

$$x = 0.10$$

$$h_3 = 243.114 + (0.10)(415.627 - 243.114)$$

$$h_3 = 260.365 \text{ kJ/kg}$$

$$h_4 = h_3 = 260.365 \text{ kJ/kg}$$

$$\text{COP} = \frac{h_1 - h_4}{h_2 - h_1} = \frac{401.555 - 260.365}{435.212 - 401.555}$$

COP = 4.20 - - - Ans.

- 13-4. Refrigerant 22 at a pressure of 1500 kPa leaves the condenser and rises vertically 10 m to the expansion valve. The pressure drop due to friction in the liquid line is 20 kPa. In order to have no vapor in the refrigerant entering the expansion valve, what is the maximum allowable temperature at that point?

Solution: say $v = v_1$

$$p_2 = p_1 - gH/v_1 - \Delta p$$

$$H = 10 \text{ m}$$

$$g = 9.81 \text{ m/s}^2$$

$$\Delta p = 20 \text{ kPa}$$

$$p_1 = 1500 \text{ kPa}$$

Table A-6.

$$v_1 = 0.8808 \text{ L/kg} = 0.0008808 \text{ m}^3/\text{kg}$$

$$p_2 = (1500)(1000) - (9.81)(10) / (0.0008808) - (20)(1000)$$

$$p_2 = 1,368.62 \text{ kPa}$$

Table A-6.

$$t_2 = 35.4 \text{ C} \text{ --- Ans.}$$

- 13-5. A superheat-controlled expansion valve in a refrigerant 22 system is not equipped with an external equalizer. The valve supplies refrigerant to an evaporator coil and comes from the factory with a setting that requires 5K superheat in order to open the valve at an evaporator temperature of 0 C.
- What difference in pressure on opposite sides of the diaphragm is required to open the valve?
 - When the pressure at the entrance of the evaporator is 600 kPa, how much superheat is required to open the valve if the pressure drop of the refrigerant through the coil is 55 kPa?

Solution:

Using Fig. 13-15 and deriving equation by assuming parabolic curve.

Let y - pressure, kPa and x = temperature, C.

$$y_2 - y_1 = A(x_2^2 - x_1^2) + B(x_2 - x_1)$$

At 5 C evaporator temperature, 5 K superheat

100 kPa pressure differential

$$x_1 = 5 \text{ C}, x_2 = 5 \text{ C} + 5 = 10 \text{ C}$$

$$y_2 - y_1 = 100 \text{ kPa}$$

$$100 = A(10^2 - 5^2) + B(10 - 5)$$

$$100 = 75A + 5B \text{ --- Eq. 1}$$

At -30 C evaporator temperature

12 C superheat

100 kPa pressure differential

$$x_1 = -30 \text{ C}, x_2 = -30 \text{ C} + 12 = -18 \text{ C}$$

$$y_2 - y_1 = 100 \text{ kPa}$$

$$100 = A((-18)^2 - (-30)^2) + B((-18) - (-30))$$

$$100 = -576A + 12B \text{ --- Eq. 2}$$

$$\text{But } 5B = 100 - 75A$$

$$\text{Then } 100 = -576A + 12(20 - 15A)$$

$$A = 0.185185$$

$$B = 17.222222$$

Therefore:

$$y_2 - y_1 = 0.185185 (x_2^2 - x_1^2) + 17.222222(x_2 - x_1)$$

(a) At 0 C evaporator temperature, 5 K superheat

$$x_1 = 0 \text{ C}$$

$$x_2 = 0 \text{ C} + 5 = 5 \text{ C}$$

$$y_2 - y_1 = 0.185185 (5^2 - 0^2) + 17.222222(5 - 0)$$

$$y_2 - y_1 = \mathbf{90.74 \text{ kPa} \text{ --- Ans.}}$$

(b) At 0 C evaporator temperature, $p = 497.59 \text{ kPa}$

$$\Delta p = 600 \text{ kPa} + 55 \text{ kPa} - 497.59 \text{ kPa} = 157.41 \text{ kPa.}$$

$$x_1 = 0 \text{ C}$$

Then

$$157.41 = 0.185185 (x_2^2 - 0^2) + 17.222222(x_2 - 0)$$

$$x_2 = 8.4 \text{ C}$$

$$x_2 - x_1 = \mathbf{8.4 \text{ K} \text{ --- Ans.}}$$

- 13-6. The catalog of an expansion valve manufacturer specifies a refrigerating capacity of 45 kW for a certain valve when the pressure difference across the valve is 500 kPa. The catalog ratings apply when vapor-free liquid at 37.8 C enters the expansion valve and the evaporator temperature is 4.4 C. What is the expected rating of the valve when the pressure difference across it is 1200 kPa?

Solution:

Eq. 13-22

$$\text{Velocity} = C\sqrt{2(\text{pressuredifference})} \text{ m/s}$$

With all other data as constant except for pressure difference and refrigerating capacity.

$$\text{Refrigerating Capacity} \propto \sqrt{2(\text{pressuredifference})} \text{ m/s}$$

Then:

New Refrigerating Capacity

$$= (45 \text{ kW}) \sqrt{\frac{1200 \text{ kPa}}{500 \text{ kPa}}}$$

$$= \mathbf{69.7 \text{ kW} \text{ ---- Ans.}}$$

- 0 0 0 -

- 14-1. Either graphically or by using the computer, for an ambient temperature of 30 C develop the performance characteristics of a condensing unit (of the form of Fig. 14-6 or Table 14-3) if the compressor has performance shown by Fig. 14-1 [or Eq. (14-1) and (14-2)] and the condenser has characteristics shown by Fig. 14-3 [or Eq. (14-4)].

Solution: Use mathematical computation:

Use Fig. 14-3 or Eq. 14-4

$$q_c = (9.39 \text{ kW/K})(t_c - t_{amb})$$

at 30 C

$$q_c = (9.39 \text{ kW/K})(t_c - 30)$$

Range of Evaporator Temperature, Fig. 14-1.

-10 C, -5 C, 0 C, 5 C, and 10 C.

Eq. (14-1), constant at Table 14-1, Fig. 14-1.

$$q_e = c_1 + c_2 t_e + c_3 t_e^2 + c_4 t_c + c_5 t_c^2 + c_6 t_e t_c + c_7 t_e^2 t_c + c_8 t_e t_c^2 + c_9 t_e^2 t_c^2$$

Eq. (14-2) constant at Table 14-1, Fig. 14-1.

$$P = d_1 + d_2 t_e + d_3 t_e^2 + d_4 t_c + d_5 t_c^2 + d_6 t_e t_c + d_7 t_e^2 t_c + d_8 t_e t_c^2 + d_9 t_e^2 t_c^2$$

Eq. (14-3)

$$q_c = q_e + P$$

Solving for t_c at $t_e = -10$ C

$$\begin{aligned} q_e &= 137.402 + 4.60437(-10) + 0.061652(-10)^2 - 1.118157t_c - 0.001525t_c^2 \\ &\quad - 0.0109119(-10)t_c - 0.00040148(-10)^2 t_c - 0.00026682(-10)t_c^2 \\ &\quad + 0.000003873(-10)^2 t_c^2 \end{aligned}$$

$$q_e = 97.5235 - 1.049186t_c + 0.0015305t_c^2$$

$$\begin{aligned} P &= 1.00618 - 0.893222(-10) - 0.01426(-10)^2 + 0.870024t_c - 0.0063397t_c^2 \\ &\quad + 0.033889(-10)t_c - 0.00023875(-10)^2 t_c - 0.00014746(-10)t_c^2 \\ &\quad + 0.0000067962(-10)^2 t_c^2 \end{aligned}$$

$$P = 8.5124 + 0.507259t_c - 0.00418548t_c^2$$

$$q_c = q_e + P$$

$$q_c = 106.0359 - 0.541927t_c - 0.00265498t_c^2$$

Then,

$$q_c = (9.39 \text{ kW/K})(t_c - 30)$$

$$9.39t_c - 281.7 = 106.0359 - 0.541927t_c - 0.00265498t_c^2$$

$$0.00265498t_c^2 + 9.931927t_c - 387.7359 = 0$$

$$t_c = 38.64 \text{ C}$$

$$q_e = 97.5235 - 1.049186(38.64) + 0.0015305(38.64)^2$$

$$q_e = 59.3 \text{ kW at } t_e = -10 \text{ C.}$$

Solving for t_c at $t_e = -5 \text{ C}$

$$q_e = 137.402 + 4.60437(-5) + 0.061652(-5)^2 - 1.118157t_c - 0.001525t_c^2 \\ - 0.0109119(-5)t_c - 0.00040148(-5)^2t_c - 0.00026682(-5)t_c^2 \\ + 0.000003873(-5)^2t_c^2$$

$$q_e = 115.92145 - 1.0736345t_c + 0.000094075t_c^2$$

$$P = 1.00618 - 0.893222(-5) - 0.01426(-5)^2 + 0.870024t_c - 0.0063397t_c^2 \\ + 0.033889(-5)t_c - 0.00023875(-5)^2t_c - 0.00014746(-5)t_c^2 \\ + 0.0000067962(-5)^2t_c^2$$

$$P = 5.11579 + 0.69461025t_c - 0.005432495t_c^2$$

$$q_c = q_e + P$$

$$q_c = 121.03724 - 0.37902425t_c - 0.00552657t_c^2$$

$$9.39t_c - 281.7 = 121.03724 - 0.37902425t_c - 0.00552657t_c^2$$

$$0.00552657t_c^2 + 9.76902425t_c - 402.73724 = 0$$

$$t_c = 40.31 \text{ C}$$

$$q_e = 115.92145 - 1.0736345(40.31) + 0.000094075(40.31)^2$$

$$q_e = 72.5 \text{ kW at } t_e = -5 \text{ C.}$$

Solving for t_c at $t_e = 0 \text{ C}$

$$q_e = 137.402 + 4.60437(0) + 0.061652(0)^2 - 1.118157t_c - 0.001525t_c^2 \\ - 0.0109119(0)t_c - 0.00040148(0)^2t_c - 0.00026682(0)t_c^2 \\ + 0.000003873(0)^2t_c^2$$

$$q_e = 137.402 - 1.118157t_c + 0.0001525t_c^2$$

$$P = 1.00618 - 0.893222(0) - 0.01426(0)^2 + 0.870024t_c - 0.0063397t_c^2 \\ + 0.033889(0)t_c - 0.00023875(0)^2t_c - 0.00014746(0)t_c^2 \\ + 0.0000067962(0)^2t_c^2$$

$$P = 1.00618 + 0.870024t_c - 0.0063397t_c^2$$

$$q_c = q_e + P$$

$$q_c = 138.40818 - 0.248133t_c - 0.0078647t_c^2$$

$$9.39t_c - 281.7 = 138.40818 - 0.248133t_c - 0.0078647t_c^2$$

$$0.0078647t_c^2 + 9.638133t_c - 420.10818 = 0$$

$$t_c = 42.14 \text{ C}$$

$$q_e = 137.402 - 1.118157(42.14) + 0.001525(42.14)^2$$

$$q_e = 87.6 \text{ kW at } t_e = 0 \text{ C.}$$

Solving for t_c at $t_e = 5 \text{ C}$

$$q_e = 137.402 + 4.60437(5) + 0.061652(5)^2 - 1.118157t_c - 0.001525t_c^2$$

$$- 0.0109119(5)t_c - 0.00040148(5)^2 t_c - 0.00026682(5)t_c^2$$

$$+ 0.000003873(5)^2 t_c^2$$

$$q_e = 161.96515 - 1.1827535t_c + 0.002762275t_c^2$$

$$P = 1.00618 - 0.893222(5) - 0.01426(5)^2 + 0.870024t_c - 0.0063397t_c^2$$

$$+ 0.033889(5)t_c - 0.00023875(5)^2 t_c - 0.00014746(5)t_c^2$$

$$+ 0.0000067962(5)^2 t_c^2$$

$$P = -3.81643 + 1.03350025t_c - 0.006907095t_c^2$$

$$q_c = q_e + P$$

$$q_c = 158.14872 - 0.14925325t_c - 0.00966937t_c^2$$

$$9.39t_c - 281.7 = 158.14872 - 0.14925325t_c - 0.00966937t_c^2$$

$$0.00966937t_c^2 + 9.53925325t_c - 439.84872 = 0$$

$$t_c = 44.14 \text{ C}$$

$$q_e = 161.96515 - 1.1827535(44.14) + 0.002762275(44.14)^2$$

$$q_e = 104.4 \text{ kW at } t_e = 5 \text{ C.}$$

Solving for t_c at $t_e = 10 \text{ C}$

$$q_e = 137.402 + 4.60437(10) + 0.061652(10)^2 - 1.118157t_c - 0.001525t_c^2$$

$$- 0.0109119(10)t_c - 0.00040148(10)^2 t_c - 0.00026682(10)t_c^2$$

$$+ 0.000003873(10)^2 t_c^2$$

$$q_e = 189.6109 - 1.267424t_c + 0.0038059t_c^2$$

$$P = 1.00618 - 0.893222(10) - 0.01426(10)^2 + 0.870024t_c - 0.0063397t_c^2$$

$$+ 0.033889(10)t_c - 0.00023875(10)^2t_c - 0.00014746(10)t_c^2$$

$$+ 0.0000067962(10)^2t_c^2$$

$$P = -3.81643 + 1.03350025t_c - 0.006907095t_c^2$$

$$q_c = q_e + P$$

$$q_c = 180.25886 - 0.082435t_c - 0.01094058t_c^2$$

$$9.39t_c - 281.7 = 180.25886 - 0.082435t_c - 0.01094058t_c^2$$

$$0.01094058t_c^2 + 9.472435t_c - 461.95886 = 0$$

$$t_c = 46.29 \text{ C}$$

$$q_e = 189.6109 - 1.267424(46.29) + 0.0038059(46.29)^2$$

$$q_e = 122.8 \text{ kW at } t_e = 10 \text{ C.}$$

Ans.

qe, kw	122.8	104.4	87.6	72.5	59.3
te, C	10	5	0	-5	-10
tc, C	46.29	44.14	42.14	40.31	38.64

14-2. Combine the condensing unit of Problem 14-1 (using answers provided) with the evaporator of Fig. 14-8 to form a complete system. The water flow rate to the evaporator is 2 kg/s, and the temperature of water to be chilled is 10 C.

- (a) What are the refrigerating capacity and power requirement of this system?
 (b) This system pumps heat between 10 C and an ambient temperature of 30 C, which is the same temperature difference as from 15 to 35 C, for which information is available in Table 14-4. Explain why the refrigerating capacity and power requirement are less at the lower temperature level.

Solution:

- (a) Eq. 14-6.
 $q_e = 6.0[1 + 0.046(t_{wi} - t_e)](t_{wi} - t_e)$
 $t_{wi} = 10 \text{ C}$
 Expressing $q_e = f(t_e)$ from Problem 14-1.
 $q_e = 87.5914 + 3.178t_e + 0.03457t_e^2$
 Then:
 $q_e = 6.0[1 + 0.046(10 - t_e)](10 - t_e)$
 $q_e = (60 - 6t_e)(1.46 - 0.046t_e)$
 $q_e = 87.6 - 11.52t_e + 0.276t_e^2$
 $87.6 - 11.52t_e + 0.276t_e^2 = 87.5914 + 3.178t_e + 0.03457t_e^2$
 $0.24143t_e^2 - 14.698t_e + 0.0086 = 0$
 $t_e \approx 0 \text{ C}, t_c = 42.14 \text{ C}$
 Then, $q_e = 87.6 \text{ kw} \text{ --- Ans.}$

$$P = 1.00618 + 0.870024t_c - 0.0063397t_c^2$$

$$P = 1.00618 + 0.870024(42.14) - 0.0063397(42.14)^2$$

P = 26.4 kw - - - Ans.

$$q_c = q_e + p = 87.6 \text{ kw} + 26.4 \text{ kw} = 114 \text{ kw}$$

(b) At lower temperature level, if $t_{wi} = 15 \text{ C}$ and ambient temperature = 35 C .

From Fig. 14-9.

15 C Entering Water Temperature

35 C Ambient Temperature

$t_e = \text{Evaporator Temp} = 4.4 \text{ C}$

$q_e = \text{Refrigerating Capacity} = 96 \text{ kw}$

Table 14-3.

$P = 30 \text{ kw}$

$t_c = 48.4 \text{ C}$

$q_c = 125.8 \text{ kw}$

Answer.

All values above are higher than low temperature level. Therefore refrigerating capacity and power are less at low temperature level due to lower ambient temperature and lower entering water temperature to be chilled.

14-3. Section 14-11 suggests that the influences of the several components shown in Table 14-6 are dependent upon the relative sizes of the components at the base condition. If the base system is the same as that tabulated in Table 14-6 except that the condenser is twice as large [$F = 18.78 \text{ kW/K}$ in Eq. (14-4)], what is the increase in system capacity of a 10 percent increase in condenser capacity above this new base condition? The ambient temperature is 35 C , and the entering temperature of the water to be chilled is 15 C .

Solution:

35 C ambient temperature, t_{amb} .

15 C entering temperature of water, t_{wi} .

Eq. 14-4.

$$q_c = F(t_c - t_{amb})$$

$$q_c = 18.78(t_c - 35)$$

Eq. 14-6

$$q_e = 6.0[1 + 0.046(t_{wi} - t_e)](t_{wi} - t_e)$$

$$q_e = 6.0[1 + 0.046(15 - t_e)](15 - t_e)$$

Eq. 14-1.

$$q_e = 137.402 + 4.60437t_e + 0.061652t_e^2 - 1.118157t_c - 0.001525t_c^2 - 0.0109119t_e t_c - 0.00040148t_e^2 t_c - 0.00026682t_e t_c^2 + 0.000003873t_e^2 t_c^2$$

Eq. 14-2.

$$P = 1.00618 - 0.893222t_e - 0.01426t_e^2 + 0.870024t_c - 0.0063397t_c^2 + 0.033889t_e t_c - 0.00023875t_e^2 t_c - 0.00014746t_e t_c^2 + 0.0000067962t_e^2 t_c^2$$

Eq. 14-3.

$$q_c = q_e + P$$

$$q_c = 138.40818 + 3.711148t_e + 0.047392t_e^2 - 0.248133t_c - 0.0078647t_c^2 + 0.0229771t_e t_c - 0.00064023t_e^2 t_c - 0.00041428t_e t_c^2 + 0.0000106692t_e^2 t_c^2$$

Use q_c :

$$18.78(t_c - 35) = 138.40818 + 3.711148t_e + 0.047392t_e^2 - 0.248133t_c - 0.0078647t_c^2 + 0.0229771t_e t_c - 0.00064023t_e^2 t_c - 0.00041428t_e t_c^2 + 0.0000106692t_e^2 t_c^2$$

Let Equation A is,

$$795.70818 + 3.711148t_e + 0.047392t_e^2 - 19.028133t_c - 0.0078647t_c^2 + 0.0229771t_e t_c - 0.00064023t_e^2 t_c - 0.00041428t_e t_c^2 + 0.0000106692t_e^2 t_c^2 = 0$$

Use q_e :

$$6.0[1 + 0.046(15 - t_e)](15 - t_e) = (90 - 6t_e)(1.69 - 0.046t_e) = 152.1 - 14.28t_e + 0.276t_e^2 = 137.402 + 4.60437t_e + 0.061652t_e^2 - 1.118157t_c - 0.001525t_c^2 - 0.0109119t_e t_c - 0.00040148t_e^2 t_c - 0.00026682t_e t_c^2 + 0.000003873t_e^2 t_c^2$$

Let Equation B is,

$$X = 18.88437t_e - 0.214348t_e^2 - 1.118157t_c - 0.001525t_c^2 - 0.0109119t_e t_c - 0.00040148t_e^2 t_c - 0.00026682t_e t_c^2 + 0.000003873t_e^2 t_c^2 = 14.698$$

Assume a value of t_e , solve t_c from Equation A then substitute in Equation B to reach 14.698 value.

Say $t_e = 0$ C

Equation A.

$$795.70818 + 3.711148(0) + 0.047392(0)^2 - 19.028133t_c - 0.0078647t_c^2 + 0.0229771(0)t_c - 0.00064023(0)^2 t_c - 0.00041428(0)t_c^2 + 0.0000106692(0)^2 t_c^2 = 0$$

$$0.0078647t_c^2 + 19.028133t_c - 795.70818 = 0$$

$$t_c = 41.12$$
 C

Equation B.

$$X = 18.88437(0) - 0.214348(0)^2 - 1.118157(41.12) - 0.001525(41.12)^2 - 0.0109119(0)(41.12) - 0.00040148(0)^2 (41.12) - 0.00026682(0)(41.12)^2 + 0.000003873(0)^2 (41.12)^2 = -48.56 > 14.698$$

Say $t_e = 5$ C

Equation A.

$$795.70818 + 3.711148(5) + 0.047392(5)^2 - 19.028133t_c - 0.0078647t_c^2 + 0.0229771(5)t_c - 0.00064023(5)^2 t_c - 0.00041428(5)t_c^2 + 0.0000106692(5)^2 t_c^2 = 0$$

$$0.00966937t_c^2 + 18.92925325t_c - 815.44872 = 0$$

$$t_c = 42.17 \text{ C}$$

Equation B.

$$X = 18.88437(5) - 0.214348(5)^2 - 1.118157(42.17) - 0.001525(42.17)^2$$

$$- 0.0109119(5)(42.17) - 0.00040148(5)^2(42.17) - 0.00026682(5)(42.17)^2$$

$$+ 0.000003873(5)^2(42.17)^2 = 34.27 > 14.698$$

Say $t_e = 4 \text{ C}$

Equation A.

$$795.70818 + 3.711148(4) + 0.047392(4)^2 - 19.028133t_c - 0.0078647t_c^2 +$$

$$0.0229771(4)t_c - 0.00064023(4)^2t_c - 0.00041428(4)t_c^2$$

$$+ 0.0000106692(4)^2t_c^2 = 0$$

$$0.0093511128t_c^2 + 18.94646828t_c - 811.311044 = 0$$

$$t_c = 41.95 \text{ C}$$

Equation B.

$$X = 18.88437(4) - 0.214348(4)^2 - 1.118157(41.95) - 0.001525(41.95)^2$$

$$- 0.0109119(4)(41.95) - 0.00040148(4)^2(41.95) - 0.00026682(4)(41.95)^2$$

$$+ 0.000003873(4)^2(41.95)^2 = 18.65 > 14.698$$

Say $t_e = 3.5 \text{ C}$

Equation A.

$$795.70818 + 3.711148(3.5) + 0.047392(3.5)^2 - 19.028133t_c - 0.0078647t_c^2 +$$

$$0.0229771(3.5)t_c - 0.00064023(3.5)^2t_c - 0.00041428(3.5)t_c^2$$

$$+ 0.0000106692(3.5)^2t_c^2 = 0$$

$$0.0091839823t_c^2 + 18.95555597t_c - 809.27775 = 0$$

$$t_c = 41.845 \text{ C}$$

Equation B.

$$X = 18.88437(3.5) - 0.214348(3.5)^2 - 1.118157(41.845) - 0.001525(41.845)^2$$

$$- 0.0109119(3.5)(41.845) - 0.00040148(3.5)^2(41.845)$$

$$- 0.00026682(3.5)(41.845)^2 + 0.000003873(3.5)^2(41.845)^2 = 10.645 < 14.698$$

Say $t_e = 3.75 \text{ C}$

Equation A.

$$795.70818 + 3.711148(3.75) + 0.047392(3.75)^2 - 19.028133t_c - 0.0078647t_c^2 \\ + 0.0229771(3.75)t_c - 0.00064023(3.75)^2 t_c - 0.00041428(3.75)t_c^2 \\ + 0.0000106692(3.75)^2 t_c^2 = 0$$

$$0.009268214375t_c^2 + 18.95097211t_c - 810.291435 = 0 \\ t_c = 41.90 \text{ C}$$

Equation B.

$$X = 18.88437(3.75) - 0.214348(3.75)^2 - 1.118157(41.90) - 0.001525(41.90)^2 \\ - 0.0109119(3.75)(41.90) - 0.00040148(3.75)^2(41.90) \\ - 0.00026682(3.75)(41.90)^2 + 0.000003873(3.75)^2(41.90)^2 \\ = 14.662 \approx 14.698$$

Therefore: $t_e = 3.75 \text{ C}$ and $t_c = 41.90 \text{ C}$

$$q_e = 137.402 + 4.60437(3.75) + 0.061652(3.75)^2 - 1.118157(41.90) \\ - 0.001525(41.90)^2 - 0.0109119(3.75)(41.90) - 0.00040148(3.75)^2(41.90) \\ - 0.00026682(3.75)(41.90)^2 + 0.000003873(3.75)^2(41.90)^2 \\ q_e = 102.4 \text{ kW}$$

or

$$q_e = 6.0[1 + 0.046(15 - 3.75)](15 - 3.75) \\ q_e = 102.4 \text{ kW}$$

$$P = 1.00618 - 0.893222(3.75) - 0.01426(3.75)^2 + 0.870024(41.90) \\ - 0.0063397(41.90)^2 + 0.033889(3.75)(41.90) - 0.00023875(3.75)^2(41.90) \\ - 0.00014746(3.75)(41.90)^2 + 0.0000067962(3.75)^2(41.90)^2$$

$$P = 27.3 \text{ kW}$$

$$q_c = q_e + P = 102.4 \text{ kW} + 27.3 \text{ kW} = 129.7 \text{ kW}$$

$$\text{or } q_c = 18.78 (t_c - 35) = 18.78 (41.90 - 35) = 129.6 \text{ kW}$$

New Base Conditions:

Compressor = 27.3 kw

Condenser = 129.7 kw

Evaporator = 102.4 kw

If condenser capacity is increased by 10 %

$$F = 18.78 \times 1.1 = 20.658$$

Equation A:

$$\begin{aligned}
 20.658(t_c - 35) &= 138.40818 + 3.711148t_e + 0.047392t_e^2 - 0.248133t_c \\
 &- 0.0078647t_c^2 + 0.0229771t_e t_c - 0.00064023t_e^2 t_c - 0.00041428t_e t_c^2 \\
 &+ 0.0000106692t_e^2 t_c^2 \\
 861.43818 + 3.711148t_e + 0.047392t_e^2 - 20.906137t_c - 0.0078647t_c^2 + \\
 0.0229771t_e t_c - 0.00064023t_e^2 t_c - 0.00041428t_e t_c^2 + 0.0000106692t_e^2 t_c^2 &= 0
 \end{aligned}$$

Say $t_e = 3.75$ C

Equation A.

$$\begin{aligned}
 861.43818 + 3.711148(3.75) + 0.047392(3.75)^2 - 20.906137t_c - 0.0078647t_c^2 \\
 + 0.0229771(3.75)t_c - 0.00064023(3.75)^2 t_c - 0.00041428(3.75)t_c^2 \\
 + 0.0000106692(3.75)^2 t_c^2 = 0
 \end{aligned}$$

$$0.0092682144t_c^2 + 20.828976t_c - 876.021435 = 0$$

$$t_c = 41.30$$
 C

Equation B.

$$\begin{aligned}
 X &= 18.88437(3.75) - 0.214348(3.75)^2 - 1.118157(41.30) - 0.001525(41.30)^2 \\
 &- 0.0109119(3.75)(41.30) - 0.00040148(3.75)^2(41.30) \\
 &- 0.00026682(3.75)(41.30)^2 + 0.000003873(3.75)^2(41.30)^2 \\
 &= 15.484 \approx 14.698
 \end{aligned}$$

Say $t_e = 3.70$ C

Equation A.

$$\begin{aligned}
 861.43818 + 3.711148(3.7) + 0.047392(3.7)^2 - 20.906137t_c - 0.0078647t_c^2 \\
 + 0.0229771(3.7)t_c - 0.00064023(3.7)^2 t_c - 0.00041428(3.7)t_c^2 \\
 + 0.0000106692(3.7)^2 t_c^2 = 0
 \end{aligned}$$

$$0.00925147465t_c^2 + 20.8298865t_c - 875.818224 = 0$$

$$t_c = 41.29$$
 C

Equation B.

$$\begin{aligned}
 X &= 18.88437(3.7) - 0.214348(3.7)^2 - 1.118157(41.29) - 0.001525(41.29)^2 \\
 &- 0.0109119(3.7)(41.29) - 0.00040148(3.7)^2(41.29) \\
 &- 0.00026682(3.7)(41.29)^2 + 0.000003873(3.7)^2(41.29)^2 \\
 &= 14.682 \approx 14.698
 \end{aligned}$$

Then: $t_e = 3.70$ C and $t_c = 41.29$ C

$$\begin{aligned}
 q_e &= 137.402 + 4.60437(3.7) + 0.061652(3.7)^2 - 1.118157(41.29) \\
 &- 0.001525(41.29)^2 - 0.0109119(3.7)(41.29) - 0.00040148(3.7)^2(41.29) \\
 &- 0.00026682(3.7)(41.29)^2 + 0.000003873(3.7)^2(41.29)^2
 \end{aligned}$$

$$q_e = 103 \text{ kW}$$

or

$$q_e = 6.0[1 + 0.046(15 - 3.70)](15 - 3.70)$$

$$q_e = 103.04 \text{ kW}$$

$$P = 1.00618 - 0.893222(3.7) - 0.01426(3.7)^2 + 0.870024(41.29) - 0.0063397(41.29)^2 + 0.033889(3.7)(41.29) - 0.00023875(3.7)^2(41.29) - 0.00014746(3.7)(41.29)^2 + 0.0000067962(3.7)^2(41.29)^2$$

$$P = 27.0 \text{ kW}$$

$$q_c = q_e + P = 103 \text{ kW} + 27 \text{ kW} = 130 \text{ kW}$$

$$\text{or } q_c = 20.658 (t_c - 35) = 20.658 (41.29 - 35) = 130 \text{ kW}$$

$$\text{Increase in system capacity} = \frac{103.04 \text{ kw} - 102.4 \text{ kw}}{102.4 \text{ kw}} \times 100\%$$

$$\text{Increase in system capacity} = \mathbf{0.62 \% \text{ --- Ans.}}$$

14-4. For the components of the complete system described in Secs. 14-7, 14-8, and 14-11 the following costs (or savings) are applicable to a 1 percent change in component capacity. An optimization is now to proceed by increasing or decreasing sizes of components in order to reduce the first cost of the system. What relative changes in components sizes should be made in order to reduce the first cost of the system but maintain a fixed refrigerating capacity?

Component	Increase (saving) in first cost for 1 % increase (decrease) in component capacity
Compressor	\$ 2.80
Condenser	0.67
Evaporator	1.40

Solution:

Tabulation of increase and decrease.

Compressor	Condenser	Evaporator	Total Increase/Reduction
-2.80	+0.67	+1.40	-0.73
-2.80	-0.67	+1.40	-2.07
-2.80	+0.67	-1.40	-3.53
-2.80	-0.67	-1.40	-4.87
+2.80	+0.67	+1.40	+4.87
+2.80	-0.67	+1.40	+3.53
+2.80	+0.67	-1.40	+2.07
+2.80	-0.67	-1.40	+0.73

The compressor should be increased to avoid freezing of water. So try evaporation reduced by 3 % or 2 %.

Compressor	Condenser	Evaporator	Total Increase/ Reduction
+2.80	+0.67	-3(1.40)	-0.73
+2.80	-0.67	-3(1.40)	-2.07
+2.80	-0.67	-2(1.40)	-0.67 > -0.73
+2.80	+0.00	-3(1.40)	-1.40

Answer: Therefore use 3% evaporator capacity decrease for every 1 % increase in compressor capacity

- 0 0 0 -

- 15-1. The machine room housing the compressor and condenser of a refrigerant 12 system has dimensions 5 by 4 by 3 m. Calculate the mass of the refrigerant which would have to escape into the space to cause a toxic concentration for a 2-h exposure.

Solution:

Section 15-7, Refrigerant 12 exposure for 2-h has 20 % by volume to become toxic.

$$\text{Room volume} = 5 \times 4 \times 3 \text{ m} = 60 \text{ m}^3.$$

Volume of refrigerant 12.

$$= (0.20)(60) = 12 \text{ m}^3.$$

At atmospheric, 101.325 kPa, Table A-5.

$$v_g = 158.1254 \text{ L/kg} = 0.1581254 \text{ m}^3/\text{kg}$$

Mass of refrigerant 12.

$$= (12 \text{ m}^3) / (0.1581254 \text{ m}^3/\text{kg})$$

$$= \mathbf{76 \text{ kg} \text{ --- Ans.}}$$

- 15-2. Using data from Table 15-4 for the standard vapor-compression cycle operating with an evaporating temperature of -15 C and a condensing temperature of 30 C, calculate the mass flow rate of refrigerant per kilowatt of refrigeration and the work of compression for (a) refrigerant 22 and (b) ammonia.

Solution:

Table 15-4.

(a) Refrigerant 22.

Suction vapor flow per kW of refrigeration = 0.476 L/s

Table A-6, at -15 C evaporating temperature

$$v_{\text{suc}} = 77.68375 \text{ L/kg}$$

$$\begin{aligned} \text{mass flow rate} &= (0.476 \text{ L/s}) / (77.68375 \text{ L/kg}) \\ &= \mathbf{0.0061274 \text{ kg/s} \text{ --- Ans.}} \end{aligned}$$

Work of compression = (mass flow rate)(refrigerating effect) / COP

$$= (0.0061274 \text{ kg/s})(162.8 \text{ kJ/kg}) / 4.66$$

$$= \mathbf{0.2141 \text{ kW} \text{ --- Ans.}}$$

(b) Ammonia (717).

Suction vapor flow per kW of refrigeration = 0.476 L/s

Table A-3, at -15 C evaporating temperature

$$v_{\text{suc}} = 508.013 \text{ L/kg}$$

$$\begin{aligned} \text{mass flow rate} &= (0.476 \text{ L/s}) / (508.013 \text{ L/kg}) \\ &= \mathbf{0.00090943 \text{ kg/s} \text{ --- Ans.}} \end{aligned}$$

Work of compression = (mass flow rate)(refrigerating effect) / COP

$$= (0.00090943 \text{ kg/s})(1103.4 \text{ kJ/kg}) / 4.76$$

$$= \mathbf{0.2108 \text{ kW} \text{ --- Ans.}}$$

- 15-3. A 20% ethylene glycol solution in water is gradually cooled/
 (a) At what temperature does crystallization begin?
 (b) If the antifreeze is cooled to -25 C, what percent will have frozen into ice?

Solution:

Figure 15-1 and Figure 15-2.

(a) At point B, 20 % Ethylene Glycol
Crystallization Temperature = -8.5 C

(b) If cooled to -25 C.
 $x_1 = 0.20$
 $x_2 = 0.425$

$$\text{Percent ice} = \frac{x_1}{x_1 + x_2} (100)$$

$$\text{Percent ice} = \frac{0.20}{0.20 + 0.425} (100)$$

Percent ice = 32 % - - - Ans.

15-4. A solution of ethylene glycol and water is to be prepared for a minimum temperature of -30 C. If the antifreeze is mixed at 15 C, what is the required specific gravity of the antifreeze solution at this temperature?

Solution:

Fig. 15-1 and Fig. 15-2 at -30 C, point B
concentration = 46 % glycol
Figure. 15-3, at 15 C, 46 % glycol.

Specific gravity based on water = 1.063 - - - Ans.

15-5. For a refrigeration capacity of 30 kW, how many liters per second of 30 % solution of ethylene glycol-water must be circulated if the antifreeze enters the liquid chiller at -5 C and leaves at -10 C?

Solution

Figure 15-6.

At -5 C, cp = specific heat = 3.75 kJ/kg.K

At -10 C, cp = specific heat = 3.75 kJ/kg.K

$$q = 30 \text{ kw} = w (3.75 \text{ kJ/kg.K})(-5 \text{ C} - (-10 \text{ C}))$$

$$w = 1.60 \text{ kg/s}$$

$$\text{Specific gravity at } -7.5 \text{ C} = 1.0475$$

$$\text{Liters per second} = (1.60 \text{ kg/s})(1 / 1.0475 \text{ kg/L})$$

Liters per second = 1.53 L/s - - - Ans.

15-6. A manufacturer's catalog gives the pressure drop through the tubes of a heat-exchanger as 70 kPa for a given flow rate of water at 15 C. If a 40 % ethylene glycol-water solution at -20 C flows through the heat exchanger at the same mass flow rate as the water, what will the pressure drop be? Assume turbulent flow. At 15 C the viscosity of water is 0.00116 Pa/s.

Solution:

Equation 15-3.

$$\frac{\Delta p_a}{\Delta p_w} = \frac{f_a \frac{L_a}{D_a} \frac{V_a^2}{2} \rho_a}{f_w \frac{L_w}{D_w} \frac{V_w^2}{2} \rho_w}$$

Equation 15-4.

$$f = \frac{0.33}{Re^{0.25}}$$

$$Re = \frac{DV\rho}{\mu}$$

$$\Delta p_w = 70 \text{ kPa}$$

$$\mu_w = 0.0016 \text{ Pa}\cdot\text{s}$$

$$\rho_w = 0.99915 \text{ kg/L at } 15 \text{ C}$$

$$\frac{L_a}{D_a} = \frac{L_w}{D_w}, D_a = D_w$$

$$\frac{f_a}{f_w} = \frac{Re_w^{0.25}}{Re_a^{0.25}} = \left(\frac{\mu_a V_w \rho_w}{\mu_w V_a \rho_a} \right)^{0.25}$$

But:

$$V_w = \frac{w}{A\rho_w}; V_a = \frac{w}{A\rho_a}$$

Then:

$$\frac{f_a}{f_w} = \left(\frac{\mu_a}{\mu_w} \right)^{0.25}$$

Equation 15-3 then becomes,

$$\frac{\Delta p_a}{\Delta p_w} = \left(\frac{\mu_a}{\mu_w} \right)^{0.25} \left(\frac{\rho_a}{\rho_w} \right) \left(\frac{V_a}{V_w} \right)^2$$

$$\frac{\Delta p_a}{\Delta p_w} = \left(\frac{\mu_a}{\mu_w} \right)^{0.25} \left(\frac{\rho_a}{\rho_w} \right) \left(\frac{\rho_w}{\rho_a} \right)^2$$

$$\frac{\Delta p_a}{\Delta p_w} = \left(\frac{\mu_a}{\mu_w} \right)^{0.25} \left(\frac{\rho_w}{\rho_a} \right)$$

For 40 % Ethylene Glycol, -20 C.
Fig. 15-3, Specific Gravity = 1.069

$$\rho_a = 1.069 \text{ kg/L}$$

Fig. 15-5

$$\mu_a = 0.01884 \text{ Pa}\cdot\text{s}$$

Substitute:

$$\frac{\Delta p_a}{70} = \left(\frac{0.01884}{0.00116} \right)^{0.25} \left(\frac{0.99915}{1.069} \right)$$

$\Delta p_a = 131 \text{ kPa} \text{ --- Ans.}$

- 15-7. Compute the convection heat-transfer coefficient for liquid flowing through a 20-mm-ID tube when the velocity is 2.5 m/s if the liquid is (a) water at 15 C, which has a viscosity of 0.00116 Pa.s and a thermal conductivity of 0.584 W/m.K; (b) 40 % solution of ethylene glycol at -20 C.

Solution:

Equation 15-5.

$$h = 0.023 \frac{k}{D} \left(\frac{VD\rho}{\mu} \right)^{0.8} \left(\frac{c_p \mu}{k} \right)^{0.4}$$

(a) Water:

$$\rho = 0.99915 \text{ kg/L} = 999.15 \text{ kg/m}^3$$

$$D = 0.020 \text{ m}$$

$$\mu = 0.00116 \text{ Pa.s}$$

$$k = 0.584 \text{ W/m.K}$$

$$c_p = 4190 \text{ J/kg.K}$$

$$V = 2.5 \text{ m/s}$$

$$h = 0.023 \left(\frac{0.584}{0.020} \right) \left(\frac{(2.5)(0.020)(999.15)}{0.00116} \right)^{0.8} \left(\frac{(4190)(0.00116)}{0.584} \right)^{0.4}$$

$h = 6,177 \text{ W/m}^2 \cdot \text{K} \text{ --- Ans.}$

(b) 40 % Solution, Ethylene Glycol at -20 C

$$\rho = 1.069 \text{ kg/L (Fig. 15-3)} = 1069 \text{ kg/m}^3$$

$$D = 0.020 \text{ m}$$

$$\mu = 0.01884 \text{ Pa.s (Fig. 15-5)}$$

$$k = 0.45 \text{ W/m.K (Fig. 15-4)}$$

$$c_p = 3450 \text{ J/kg.K (Fig. 15-6)}$$

$$V = 2.5 \text{ m/s}$$

$$h = 0.023 \left(\frac{0.450}{0.020} \right) \left(\frac{(2.5)(0.020)(1069)}{0.01884} \right)^{0.8} \left(\frac{(3450)(0.01884)}{0.450} \right)^{0.4}$$

$h = 2,188 \text{ W/m}^2 \cdot \text{K} \text{ --- Ans.}$

- 0 0 0 -

- 16-1 A cylindrical tank 2 m long mounted with its axis horizontal is to separate liquid ammonia from ammonia vapor. The ammonia vapor bubbles through the liquid and 1.2 m³/s leaves the surface of the liquid. If the velocity of the vapor is limited to 1 m/s and the vessel is to operate with the liquid level two-thirds of the diameter from the bottom, what must the diameter of the tank be?

Solution:

$$L = 2 \text{ m}$$

$$\text{Surface Area} = A = (1.2 \text{ m}^3/\text{s}) / (1 \text{ m/s}) = 1.2 \text{ m}^2$$

$$\text{Width} = W = A/L = (1.2 \text{ m}^2) / (2 \text{ m}) = 0.6 \text{ m}$$

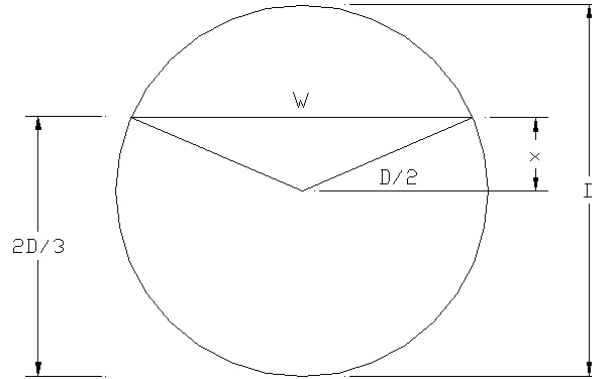

$$\frac{2}{3}D = \frac{1}{2}D + x$$

$$x = \frac{1}{2}\sqrt{D^2 - W^2}$$

$$\frac{2}{3}D = \frac{1}{2}D + \frac{1}{2}\sqrt{D^2 - W^2}$$

$$\frac{1}{3}D = \sqrt{D^2 - W^2}$$

$$\frac{8}{9}D^2 = W^2 = (0.6)^2$$

$$D = 0.636 \text{ m} \text{ --- Ans.}$$

- 16-2. A liquid subcooler as shown in Fig. 16-14 receives liquid ammonia at 30 C and subcools 0.6 kg/s to 5 C. Saturated vapor leaves the subcooler for the high-stage compressor at -1 C. Calculate the flow rate of ammonia that evaporated to cool the liquid.

Solution: Refer to Fig. 16-14.

Liquid ammonia at 30 C, Table A-3.

$$h_1 = h_f = 341.769 \text{ kJ/kg}$$

Subcooled ammonia at 5 C, Table A-3.

$$h_2 = h_f = 223.185 \text{ kJ/kg}$$

Saturated vapor ammonia at -1 C, Table A-3.

$$h_3 = h_g = 1460.62 \text{ kJ/kg}$$

Heat Balance:

$$w_1(h_1 - h_2) = w_2(h_3 - h_1)$$

$$(0.6)(341.769 - 223.185) = w_2 (1460.62 - 341.769)$$

$$w_2 = 0.0636 \text{ kg/s} \text{ --- Ans.}$$

16-3. In a refrigerant 22 refrigeration system the capacity is 180 kw at a temperature of -30 C. The vapor from the evaporator is pumped by one compressor to the condensing pressure of 1500 kPa. Later the system is revised to a two-stage compression operating on the cycle shown in Fig. 16-6 with intercooling but no removal of flash gas at 600 kPa.

- Calculate the power required by the single compressor in the original system.
- Calculate the power required by the two compressor in the revised system.

Solution:

(a) Original system

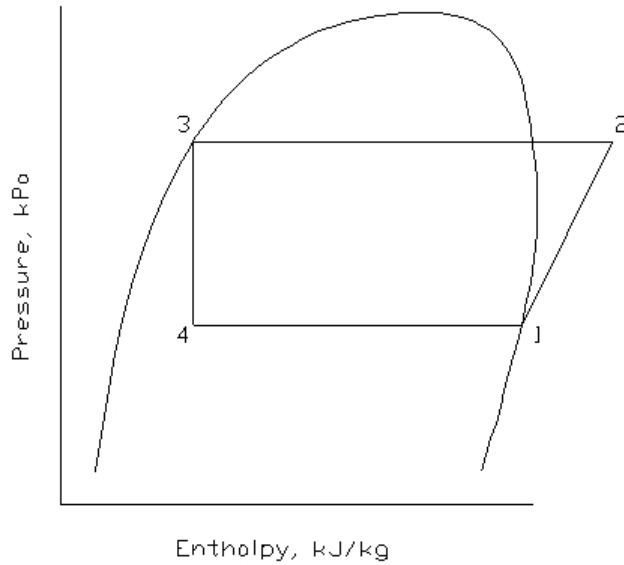

At 1, -30 C, Table A-6.

$$h_1 = 393.138 \text{ kJ/kg}$$

$$s_1 = 1.80329 \text{ kJ/kg.K}$$

At 2, 1500 kPa condensing pressure = 39.095 C condensing temp.

Table A-7, constant entropy

$$h_2 = 450.379 \text{ kJ/kg}$$

$$h_3 = h_4 = 248.486 \text{ kJ/kg}$$

$$w = 180 \text{ kw} / (h_1 - h_4)$$

$$w = 180 / (393.138 - 248.486)$$

$$w = 1.2444 \text{ kg/s}$$

$$P = w (h_2 - h_1)$$

$$P = 1.2444 (450.379 - 393.138)$$

$$P = 71.23 \text{ kw} \text{ --- Ans.}$$

(b) Revised system (Fig. 16-6).

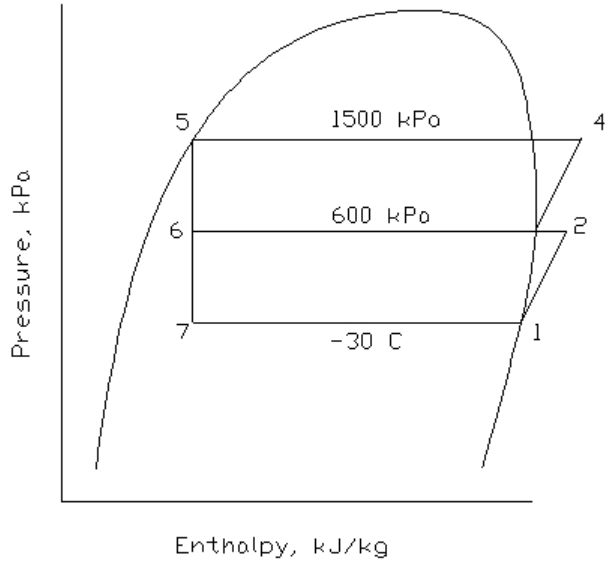

At 1, -30 C, Table A-6
 $h_1 = 393.138 \text{ kJ/kg}$
 $s_1 = 1.80329 \text{ kJ/kg.K}$

At 2, 600 kPa, Sat. Temp. = 5.877 C (Table A-7)
 Constant Entropy
 $h_2 = 424.848 \text{ kJ/kg}$

At 3, 600 kPa, Sat. Temp. = 5.877 C (Table A-6)
 $h_3 = 407.446 \text{ kJ/kg}$
 $s_3 = 1.74341 \text{ kJ/kg.K}$

At 4, 1500 kPa, Sat. Temp. = 39.095 C (Table A-7)
 $h_4 = 430.094 \text{ kJ/kg}$

At 5, 1500 kPa, Sat. Temp. = 39.095 C (Table A-6)
 $h_7 = h_6 = h_5 = 248.486 \text{ kJ/kg}$

$w_1 =$ entering low-stage compressor

$$w_1 = 180 \text{ kw} / (h_1 - h_7) = 180 / (393.138 - 248.486)$$

$$w_1 = 1.2444 \text{ kg/s}$$

$w_2 =$ enteirng intercooler

$w_3 =$ entering high-stage compressor

Heat Balance through intercooler

$$w_2 h_6 + w_1 h_2 = w_3 h_3$$

Mass Balance through intercooler

$$w_2 + w_1 = w_3$$

$$w_2 + 1.2444 = w_3$$

$$w_2 = w_3 - 1.2444$$

$$(w_3 - 1.2444)(248.486) + (1.2444)(424.848) = w_3 (407.446)$$

$$w_3 = 1.38063 \text{ kg/s}$$

$$P = w_1(h_2 - h_1) + w_3(h_4 - h_3)$$

$$P = (1.2444)(424.848 - 393.138) + (1.38063)(430.094 - 407.446)$$

$$P = 70.73 \text{ kw} \text{ --- Ans.}$$

- 16-4. A refrigerant 22 system has a capacity of 180 kw of an evaporating temperature of -30 C when the condensing pressure is 1500 kPa.
- Compute the power requirement for a system with a single compressor.
 - Compute the total power required by the two compressors in the system shown in Fig. 16-7 where there is no intercooling but there is flash-gas removal at 600 kPa?

Solution:

- Original system

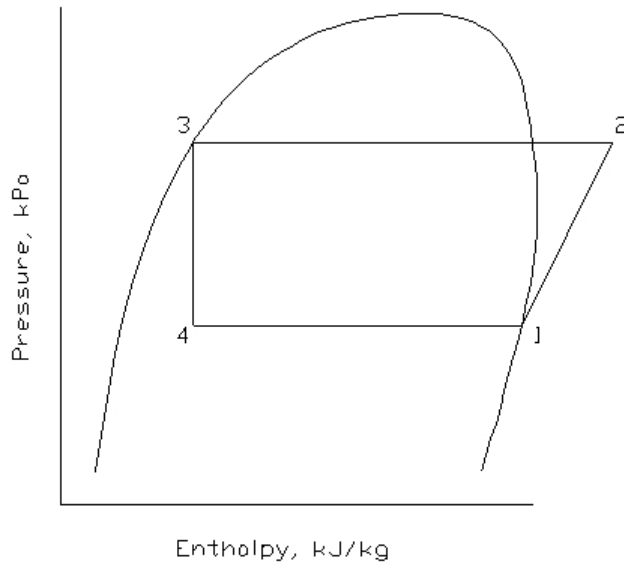

At 1, -30 C, Table A-6.
 $h_1 = 393.138 \text{ kJ/kg}$
 $s_1 = 1.80329 \text{ kJ/kg.K}$

At 2, 1500 kPa condensing pressure = 39.095 C condensing temp.
 Table A-7, constant entropy
 $h_2 = 450.379 \text{ kJ/kg}$

$$h_3 = h_4 = 248.486 \text{ kJ/kg}$$

$$w = 180 \text{ kw} / (h_1 - h_4)$$

$$w = 180 / (393.138 - 248.486)$$

$$w = 1.2444 \text{ kg/s}$$

$$P = w (h_2 - h_1)$$

$$P = 1.2444 (450.379 - 393.138)$$

P = 71.23 kw --- Ans.

(b) For Fig. 16-7.

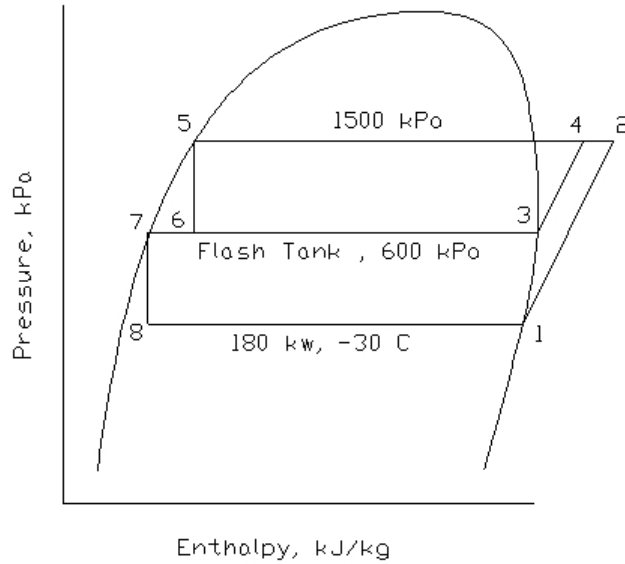

At 1, -30 C, Table A-6
 $h_1 = 393.138 \text{ kJ/kg}$
 $s_1 = 1.80329 \text{ kJ/kg.K}$

At 2, 1500 kPa, Sat. Temp. = 39.095 C (Table A-7)
 Constant Entropy
 $h_2 = 450.379 \text{ kJ/kg}$

At 3, 600 kPa, Sat. Temp. = 5.877 C (Table A-6)
 $h_3 = 407.446 \text{ kJ/kg}$
 $s_3 = 1.74341 \text{ kJ/kg.K}$

At 4, 1500 kPa, Sat. Temp. = 39.095 C (Table A-7)
 $h_4 = 430.094 \text{ kJ/kg}$

At 5, 1500 kPa, Sat. Temp. = 39.095 C (Table A-6)
 $h_5 = 248.486 \text{ kJ/kg}$

At 7, 600 kPa, Sat. Temp. = 5.877 C (Table A-6)
 $h_7 = 206.943 \text{ kJ/kg}$

$$h_6 = h_5 = 248.486 \text{ kJ/kg}$$

$$h_8 = h_7 = 206.943 \text{ kJ/kg}$$

w_1 = entering evaporator compressor

$$w_1 = 180 \text{ kw} / (h_1 - h_8) = 180 / (393.138 - 206.943)$$

$$w_1 = 0.96673 \text{ kg/s}$$

w_2 = entering flashtank

w_3 = entering flash-gas compressor

Heat Balance through intercooler

$$w_2 h_6 = w_1 h_7 + w_3 h_3$$

Mass Balance through intercooler

$$w_2 = w_1 + w_3$$

$$w_2 = 0.96673 + w_3$$

$$w_3 = 0.96673 + w_3$$

$$(w_3 + 0.96673)(248.486) = (0.96673)(206.943) + w_3(407.446)$$

$$w_3 = 0.25265 \text{ kg/s}$$

$$P = w_1(h_2 - h_1) + w_3(h_4 - h_3)$$

$$P = (0.96673)(450.3798 - 393.138) + (0.25265)(430.094 - 407.446)$$

$$P = 61.06 \text{ kw} \text{ --- Ans.}$$

- 16-5. A two-stage ammonia system using flash-gas removal and intercooling operates on the cycle shown in Fig. 16-12a. The condensing temperature is 35 C. The saturation temperature of the intermediate-temperature evaporator is 0 C, and its capacity is 150 kW. The saturation temperature of the low-temperature evaporator is -40 C, and its capacity is 250 kW. What is the rate of refrigerant compressed by the high-stage compressor?

Solution:

Refer to Fig. 16-12a.

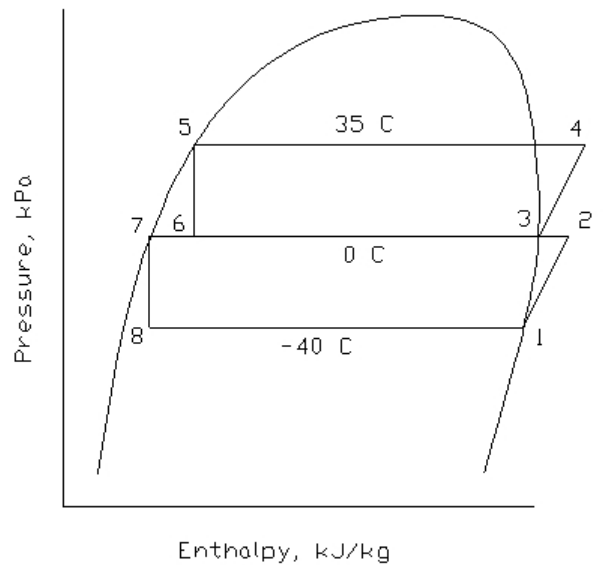

At 1, -40 C, Table A-3.

$$h_1 = 1407.26 \text{ kJ/kg}$$

$$s_1 = 6.2410 \text{ kJ/kg.K}$$

At 2, 0 C, Fig. A-1, Constant Entropy

$$h_2 = 1666 \text{ kJ/kg}$$

At 3, 0 C, Table A-3

$$h_3 = 1461.70 \text{ kJ/kg}$$

At 4, 35 C, Fig. A-1

$$h_4 = 1622 \text{ kJ/kg}$$

At 5, 35 C, Table A-3.

$$h_5 = 366.072 \text{ kJ/kg}$$

$$\text{At 6, } h_6 = h_5 = 366.072 \text{ kJ/kg}$$

At 7, 0 C, Table A-3

$$h_7 = 200 \text{ kJ/kg}$$

$$\text{At 8, } h_8 = h_7 = 200 \text{ kJ/kg.}$$

w_1 = entering low-stage compressor

$$w_1 = 250 / (h_1 - h_8)$$

$$w_1 = 250 / (1407.26 - 200)$$

$$w_1 = 0.2071 \text{ kg/s}$$

w_2 = entering high-stage compressor leaving intercooler and flashtank

Heat balance through intercooler and flashtank.

$$w_2(h_3 - h_6) = w_1(h_2 - h_7)$$

$$w_2(1461.70 - 366.072) = (0.2071)(1666 - 200)$$

$$w_2 = 0.2771 \text{ kg/s}$$

w_3 = entering intermediate temperature evaporator

$$w_3 = 150 \text{ kw} / (h_3 - h_6) = 150 / (1461.70 - 366.072)$$

$$w_3 = 0.1369 \text{ kg/s}$$

Total refrigerant compressed by high=pressure compressor

$$= w_2 + w_3 = 0.2771 + 0.1369$$

$$= \mathbf{0.4140 \text{ kg/s} \text{ --- Ans.}}$$

- 16-6. A two-stage refrigerant 22 system that uses flash-gas removal and intercooling serves a single low-temperature evaporator, as in Fig. 16-10a. The evaporator temperature is -40 C, and the condensing temperature is 30 C. The pumping capacity of the high- and low-stage compressors is shown in Fig. 16-18. What is (a) the refrigerating capacity of the system and (b) the intermediate pressure?

Solution: Refer to Fig. 16-18 and Fig. 16-10a.

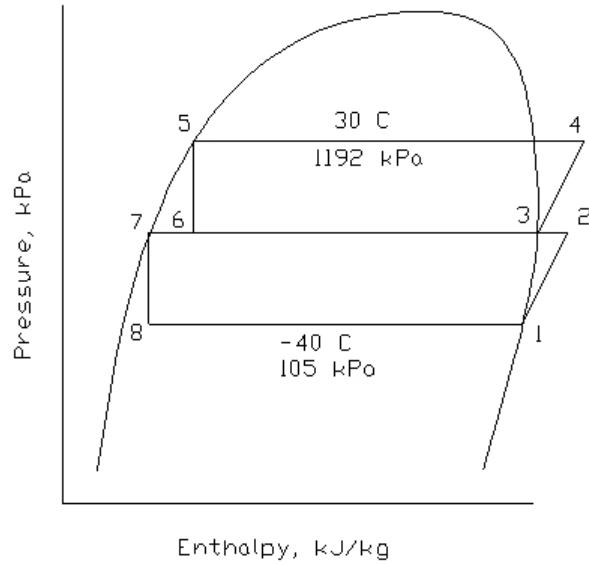

At 1, -40 C, Table A-6

$$h_1 = 388.609 \text{ kJ/kg}$$

$$s_1 = 1.82504 \text{ kJ/kg.K}$$

At 5, 30 C, Table A-6

$$h_5 = 236.664 \text{ kJ/kg}$$

Trial 1

$$p_i = \sqrt{(105)(1192)} = 354 \text{ kPa}$$

At 354 kPa, Sat. Temp. = -10 C

At 2, -10 C, Constant Entropy, Table A-7

$$h_2 = 417.46 \text{ kJ/kg}$$

At 3, -10 C, Table A-6

$$h_3 = 401.555 \text{ kJ/kg}$$

$$s_3 = 1.76713 \text{ kJ/kg.K}$$

At 4, 30 C, Constant Entropy, table A-7

$$h_4 = 431.787 \text{ kJ/kg}$$

At 6, $h_6 = h_5 = 236.664 \text{ kJ/kg}$

At 7, -10 C, Table A-6

$$h_7 = 188.426 \text{ kJ/kg}$$

At 8, $h_8 = h_7 - 188.426 \text{ kJ/kg}$

w_1 = low-stage compressor

w_2 = high-stage compressor

$$w_1(h_2 - h_7) = w_2(h_3 - h_6)$$

$$\frac{w_2}{w_1} = \frac{h_2 - h_7}{h_3 - h_6} = \frac{417.46 - 188.426}{401.555 - 236.664} = 1.139 < 1.389$$

Figure 16-18, at 354 kPa.

$$w_1 = 1.8 \text{ kg/s}$$

$$w_2 = 2.05 \text{ kg/s}$$

$$w_2/w_1 = 2.05 / 1.8 = 1.139 < 1.389$$

Next trial: $p_1 = 390 \text{ kPa}$

At 390 kPa, Sat. Temp. = -7.26 C.

At 2, -7.26 C, Constant entropy, Table A-7

$$h_2 = 419.836 \text{ kJ/kg}$$

At 3, -7.26 C, Table A-6

$$h_3 = 402.629 \text{ kJ/kg}$$

$$s_3 = 1.762776 \text{ kJ/kg.K}$$

At 4, 30 C, Constant entropy, Table A-7

$$h_4 = 430.386 \text{ kJ/kg}$$

At 6, $h_6 = h_5 = 236.664 \text{ kJ/kg}$

At 7, -7.26 C, Table A-6.

$$h_7 = 191.570 \text{ kJ/kg}$$

At 8, $h_8 = h_7 = 191.570 \text{ kJ/kg}$

$$\frac{w_2}{w_1} = \frac{h_2 - h_7}{h_3 - h_6} = \frac{419.836 - 191.570}{402.629 - 236.664} = 1.3754$$

Figure 16-18, At 390 kPa.

$$w_1 = 1.615 \text{ kg/s}$$

$$w_2 = 2.2 \text{ kg/s}$$

$$\frac{w_2}{w_1} = \frac{2.2}{1.615} = 1.36 \approx 1.3754$$

Therefore use $p_1 = 390 \text{ kPa}$

(a) $q_e = w_1(h_1 - h_8)$
 $q_e = (1.615)(388.609 - 191.570)$
 $q_e = 318 \text{ kw} \text{ --- Ans.}$

(b) $p_1 = 390 \text{ kPa} \text{ --- Ans.}$

- 17-1. What is the COP of an ideal heat-operated refrigeration cycle that receives the energizing heat from a solar collector at a temperature of 70 C, performs refrigeration at 15 C, and rejects heat to atmosphere at a temperature of 35 C?

Solution:

Eq. 17-4.

$$\text{COP} = \frac{T_r(T_s - T_a)}{T_s(T_a - T_r)}$$

$$T_s = 70 \text{ C} + 273 = 343 \text{ K}$$

$$T_r = 15 \text{ C} + 273 = 288 \text{ K}$$

$$T_a = 35 \text{ C} + 273 = 308 \text{ K}$$

$$\text{COP} = \frac{(288)(343 - 308)}{(343)(308 - 288)}$$

COP = 1.47 - - -Ans.

- 17-2. The LiBr-Water absorption cycle shown in Fig. 17-2 operates at the following temperatures: generator, 105 C; condenser, 35 C; evaporator, 5 C; and absorber, 30 C. The flow rate of solution delivered by the pump is 0.4 kg/s.

- (a) What are the mass flow rates of solution returning from the generator to the absorber and of the refrigerant?
 (b) What are the rates of heat transfer of each component, and the COP_{abs}?

Solution:

Saturation pressure at 35 C water = 5.63 kPa (condenser)

Saturation pressure at 5 C water = 0.874 kPa (evaporator)

- (a) At the generator, LiBr-Water Solution:
 Fig. 17-5, 105 C, 5.63 kPa, Refer to Fig. 17-2.
 $x_2 = 70 \%$

At the absorber, LiBr-Water
 Fig. 17-5, 30 C, 0.874 kPa
 $x_1 = 54 \%$

w_1 = LiBr-Water Solution delivered by pump.

w_2 = Solution returning from generator to absorber.

w_3 = refrigerant water flow rate.

Total mass-flow balance:

$$w_2 + w_3 = w_1 = 0.4 \text{ kg/s}$$

LiBr Balance:

$$w_1 x_1 = w_2 x_2$$

$$(0.40)(0.54) = (w_2)(0.70)$$

$$w_2 = 0.3086 \text{ kg/s}$$

Flow rate of solution = $w_2 = 0.3086 \text{ kg/s} - - - \text{Ans.}$

Flow rate of refrigerant = $w_3 = w_1 - w_2$

$$w_3 = 0.40 - 0.3086$$

$w_3 = 0.0914 \text{ kg/s} - - - \text{Ans.}$

(b) Refer to Fig. 17-6.

Enthalpies:

Enthalpies of solution, Fig. 17-8.

$$h_1 = h \text{ at } 30 \text{ C and } x \text{ of } 54 \% = -178 \text{ kJ/kg}$$

$$h_2 = h \text{ at } 105 \text{ C and } x \text{ of } 70 \% = -46 \text{ kJ/kg}$$

Enthalpy of water liquid and vapor: Table A-2

$$h_3 = h \text{ of saturated vapor at } 105 \text{ C} = 2683.75 \text{ kJ/kg}$$

$$h_4 = h \text{ of saturated liquid at } 35 \text{ C} = 146.56 \text{ kJ/kg}$$

$$h_5 = h \text{ of saturated liquid at } 5 \text{ C} = 2510.75 \text{ kJ/kg}$$

$$w_3 = w_4 = w_5 = w_c$$

Generator

$$q_g = w_3 h_3 + w_2 h_2 - w_1 h_1$$

$$q_g = (0.0914)(2683.75) + (0.3086)(-46) - (0.40)(-178)$$

$$q_g = 302.3 \text{ kW} \text{ -- Ans.}$$

Condenser

$$q_c = w_c h_3 - w_4 h_4$$

$$q_c = (0.0914)(2683.75 - 146.56)$$

$$q_c = 231.9 \text{ kW} \text{ -- Ans.}$$

Absorber

$$q_a = w_2 h_2 + w_5 h_5 - w_1 h_1$$

$$q_a = (0.3086)(-46) + (0.0914)(2510.75) - (0.4)(-178)$$

$$q_a = 286.5 \text{ kW} \text{ --- Ans.}$$

Evaporator

$$q_e = w_5 h_5 - w_4 h_4$$

$$q_e = (0.0914)(2510.75 - 146.56)$$

$$q_e = 216.1 \text{ kW} \text{ --- Ans.}$$

$$\text{COP} = q_e / q_g = (216.1 \text{ kW}) / (302.3 \text{ kW})$$

$$\text{COP} = 0.715 \text{ --- Ans.}$$

- 17-3. In the absorption cycle shown in Fig. 17-9 the solution temperature leaving the heat exchanger and entering the generator is 48 C. All other temperatures and the flow rate are as shown in Fig. 17-9. What are the rates of heat transfer at the generator and the temperature at point 4?

Solution: Refer to Fig. 17-9.

$$w_1 = w_2 = 0.6 \text{ kg/s}$$

$$w_3 = w_4 = 0.452 \text{ kg/s}$$

Heat balance through heat exchanger

$$w_3 h_3 - w_4 h_4 = w_2 h_2 - w_1 h_1$$

$$w_3 (h_3 - h_4) = w_1 (h_2 - h_1)$$

Enthalpies remain unchanged from Ex. 17-4 and Ex. 17-3.

$$h_1 = -168 \text{ kJ/kg}$$

$$h_3 = -52 \text{ kJ/kg}$$

At point 2, temperature = 48 C

Fig. 17-8, $x_1 = 50\%$ solution, 48 C

$$h_2 = -128 \text{ kJ/kg}$$

$$w_3(h_3 - h_4) = w_1(h_2 - h_1)$$

$$(0.452)(-52 - h_4) = (0.6)(-128 - (-168))$$

$$h_4 = -105.1 \text{ kJ/kg}$$

$$q_g = w_3 h_3 + w_5 h_5 - w_2 h_2$$

$$w_5 = 0.148 \text{ kg/s}$$

$$h_5 = 2676.0 \text{ kJ/kg}$$

$$q_g = (0.452)(-52) + (0.148)(2676) - (0.6)(-128)$$

$$q_g = 449.4 \text{ kW} \text{ --- Ans.}$$

At point 4, $h_4 = -105.1 \text{ kJ/kg}$, $x_3 = 66.4\%$

Fig. 17-8.

$$t_4 = 70 \text{ C} \text{ --- Ans.}$$

- 17-4. The solution leaving the heat exchanger and returning to the absorber is at a temperature of 60 C. The generator temperature is 95 C. What is the minimum condensing temperature permitted in order to prevent crystallization in the system?

Solution: Refer to Fig. 17-8.

Figure 17-8.

At crystallization, 60 C solution temperature

Percent lithium bromide = 66.4 %

Figure 17-5, $x = 66.4\%$, 95 C

Vapor pressure = 6.28 kPa

Sat. Temp. of pure water = 37 C

Minimum condensing temperature = 37 C --- Ans.

- 17-5. One of the methods of capacity control described in Sec. 17-11 is to reduce the flow rate of solution delivered by the pump: The first-order approximation is that the refrigerating capacity will be reduced by the same percentage as the solution flow rate. There are secondary effects also, because if the mean temperature of the heating medium in the generator, the cooling water in the absorber and condenser and the water being chilled in the evaporator all remain constant, the temperatures in these components will change when the heat-transfer rate decreases.
- Fill out each block in the Table 17-1 with either "increases" or "decreases" to indicate qualitative influence of the secondary effect.
 - Use the expression for an ideal heat-operated cycle to evaluate the effects of temperature on the COP_{abs} .

Solution:

Use Data of Ex. 17-3 and Ex. 17-2 and Fig. 17-6.

(a) Initial:

$$w_1 = 0.6 \text{ kg/s}$$

$$w_2 = 0.452 \text{ kg/s}$$

$$w_3 = w_4 = w_5 = 0.148 \text{ kg/s}$$

$$x_1 = 50 \%$$

$$x_2 = 66.4 \%$$

Enthalpies: Fig. 17-8.

$$h_1 = h \text{ at } 30 \text{ C and } x \text{ of } 50 \% = -168 \text{ kJ/kg}$$

$$h_2 = h \text{ at } 100 \text{ C and } x \text{ of } 60 \% = -52 \text{ kJ/kg}$$

Enthalpies: Table A-1

$$h_3 = h \text{ of saturated vapor at } 100 \text{ C} = 2676.0 \text{ kJ/kg}$$

$$h_4 = h \text{ of saturated liquid at } 40 \text{ C} = 167.5 \text{ kJ/kg}$$

$$h_5 = h \text{ of saturated vapor at } 10 \text{ C} = 2520.0 \text{ kJ/kg}$$

$$q_g = w_3 h_3 + w_2 h_2 - w_1 h_1 = 473.3 \text{ kW}$$

$$q_c = w_c h_3 - w_4 h_4 = 371.2 \text{ kW}$$

$$q_a = w_2 h_2 + w_5 h_5 - w_1 h_1 = 450.3 \text{ kW}$$

$$q_e = w_5 h_5 - w_4 h_4 = 348.2 \text{ kW}$$

$$\text{COP}_{\text{abs}} = \frac{q_e}{q_g} = 0.736$$

New Solution:

When w_1 is reduced to 0.4 kg/s (concentration of solution remains unchanged as first approximation)

$$w_1 = 0.4 \text{ kg/s}$$

$$w_2 + w_3 = w_1 = 0.4 \text{ kg/s}$$

$$w_1 x_1 = w_2 x_2$$

$$(0.4)(0.5) = w_2(0.664)$$

$$w_2 = 0.3012 \text{ kg/s}$$

$$w_3 = 0.0988 \text{ kg/s}$$

$$q_g = w_3 h_3 + w_2 h_2 - w_1 h_1$$

$$q_g = (0.0988)(2676.0) + (0.3012)(-52) - (0.4)(-168) = 315.9 \text{ kW}$$

$$q_c = w_c h_3 - w_4 h_4 \quad q_c = (0.0988)(2676.0 - 167.5) = 247.8 \text{ kW}$$

$$q_a = w_2 h_2 + w_5 h_5 - w_1 h_1$$

$$q_a = (0.3012)(-52) + (0.0988)(2520) - (0.4)(-168) = 300.5 \text{ kW}$$

$$q_e = w_5 h_5 - w_4 h_4$$

$$q_e = (0.0988)(2520.0 - 167.5) = 232.4 \text{ kW}$$

] Assume: Mean temperature of heating medium in the generator = 120 C. Mean temperature of the cooling water in the absorber and condenser = 25 C. Mean temperature of the water being chilled in the evaporator = 15 C.

New temperature of components:

$$\text{Generator} = 120 - (315.9 / 473.3)(120 - 100) = 106.6 \text{ C (increase)}$$

$$\begin{aligned} \text{Absorber} &= 25 + (300.5 / 450.3)(30 - 25) = 28.34 \text{ C (decrease)} \\ \text{Condenser} &= 25 + (247.8 / 371.2)(40 - 25) = 35.0 \text{ C (decrease)} \\ \text{Evaporator} &= 15 - (233.4 / 348.2)(15 - 10) = 11.66 \text{ C (increase)} \end{aligned}$$

With change in component temperature.

Fig. 17-5, 35 C condenser temperature, 106.6 C solution temperature
 $x_2 = 0.70$ (increase)

At 11.66 C evaporator temperature, 28.34 C solution temperature
 $x_1 = 0.46$ (decrease)

Enthalpies: Fig. 17-8.

$$h_1 = h \text{ at } 28.34 \text{ C and } x \text{ of } 46 \% = -158 \text{ kJ/kg}$$

$$h_2 = h \text{ at } 106.6 \text{ C and } x \text{ of } 70 \% = -45 \text{ kJ/kg}$$

Enthalpies: Table A-1.

$$h_3 = h \text{ of saturated vapor at } 106.6 \text{ C} = 2686.2 \text{ kJ/kg}$$

$$h_4 = h \text{ of saturated liquid at } 35 \text{ C} = 146.56 \text{ kJ/kg}$$

$$h_5 = h \text{ of saturated vapor at } 11.66 \text{ C} = 2523.0 \text{ kJ/kg}$$

$$w_1 = 0.4 \text{ kg/s}$$

$$w_2 + w_3 = w_1 = 0.4 \text{ kg/s}$$

$$w_1 x_1 = w_2 x_2$$

$$(0.4)(0.46) = w_2(0.70)$$

$$w_2 = 0.263 \text{ kg/s}$$

$$w_3 = 0.137 \text{ kg/s}$$

$$q_g = w_3 h_3 + w_2 h_2 - w_1 h_1$$

$$q_g = (0.137)(2686.2) + (0.263)(-45) - (0.4)(-158) = 419.4 \text{ kW}$$

$$q_c = w_c h_3 - w_4 h_4$$

$$q_c = (0.137)(2686.2 - 146.56) = 348 \text{ kW}$$

$$q_a = w_2 h_2 + w_5 h_5 - w_1 h_1$$

$$q_a = (0.263)(-45) + (0.137)(2523) - (0.4)(-158) = 397 \text{ kW}$$

$$q_e = w_5 h_5 - w_4 h_4$$

$$q_e = (0.137)(2523.0 - 146.56) = 325.6 \text{ kW}$$

$$\text{COP}_{\text{abs}} = \frac{q_e}{q_g} = 0.776 \text{ (increase)}$$

New temperature of components:

$$\text{Generator} = 120 - (419.4 / 473.3)(120 - 100) = 102.3 \text{ C (increase)}$$

$$\text{Absorber} = 25 + (397 / 450.3)(30 - 25) = 29.4 \text{ C (decrease)}$$

$$\text{Condenser} = 25 + (348 / 371.2)(40 - 25) = 39.1 \text{ C (decrease)}$$

$$\text{Evaporator} = 15 - (325.6 / 348.2)(15 - 10) = 10.3 \text{ C (increase)}$$

With change in component temperature.

Fig. 17-5, 35 C condenser temperature, 102.3 C solution temperature
 $x_2 = 0.675$ (increase)

At 10.3 C evaporator temperature, 29.4 C solution temperature

$$x_1 = 0.4875 \text{ (decrease)}$$

Enthalpies: Fig. 17-8.

$$h_1 = h \text{ at } 29.4 \text{ C and } x \text{ of } 48.75 \% = -165 \text{ kJ/kg}$$

$$h_2 = h \text{ at } 102.3 \text{ C and } x \text{ of } 67.5 \% = -50 \text{ kJ/kg}$$

Enthalpies: Table A-1.

$$h_3 = h \text{ of saturated vapor at } 102.3 \text{ C} = 2679.6 \text{ kJ/kg}$$

$$h_4 = h \text{ of saturated liquid at } 39.1 \text{ C} = 163.7 \text{ kJ/kg}$$

$$h_5 = h \text{ of saturated vapor at } 10.3 \text{ C} = 2520.5 \text{ kJ/kg}$$

$$w_1 = 0.4 \text{ kg/s}$$

$$w_2 + w_3 = w_1 = 0.4 \text{ kg/s}$$

$$w_1 x_1 = w_2 x_2$$

$$(0.4)(0.4875) = w_2(0.675)$$

$$w_2 = 0.2889 \text{ kg/s}$$

$$w_3 = 0.1111 \text{ kg/s}$$

$$q_g = w_3 h_3 + w_2 h_2 - w_1 h_1$$

$$q_g = (0.1111)(2679.6) + (0.2889)(-50) - (0.4)(-165) = 349.3 \text{ kW}$$

$$q_c = w_c h_3 - w_4 h_4$$

$$q_c = (0.1111)(2679.6 - 163.7) = 279.5 \text{ kW}$$

$$q_a = w_2 h_2 + w_5 h_5 - w_1 h_1$$

$$q_a = (0.2889)(-50) + (0.1111)(2520.5) - (0.4)(-165) = 331.6 \text{ kW}$$

$$q_e = w_5 h_5 - w_4 h_4$$

$$q_e = (0.1111)(2520.5 - 163.7) = 261.8 \text{ kW}$$

$$\text{COP}_{\text{abs}} = \frac{q_e}{q_g} = 0.749 \text{ (increase)}$$

New temperature of components:

$$\text{Generator} = 120 - (349.3 / 473.3)(120 - 100) = 105.2 \text{ C (increase)}$$

$$\text{Absorber} = 25 + (331.6 / 450.3)(30 - 25) = 28.7 \text{ C (decrease)}$$

$$\text{Condenser} = 25 + (279.5 / 371.2)(40 - 25) = 36.3 \text{ C (decrease)}$$

$$\text{Evaporator} = 15 - (261.8 / 348.2)(15 - 10) = 11.24 \text{ C (increase)}$$

With change in component temperature.

Fig. 17-5, 36.3 C condenser temperature, 105.2 C solution temperature

$$x_2 = 0.6975 \text{ (increase)}$$

At 11.24 C evaporator temperature, 28.7 C solution temperature

$$x_1 = 0.475 \text{ (decrease)}$$

Enthalpies: Fig. 17-8.

$$h_1 = h \text{ at } 28.7 \text{ C and } x \text{ of } 47.5 \% = -162 \text{ kJ/kg}$$

$$h_2 = h \text{ at } 105.2 \text{ C and } x \text{ of } 69.75 \% = -45 \text{ kJ/kg}$$

Enthalpies: Table A-1.

$$h_3 = h \text{ of saturated vapor at } 105.2 \text{ C} = 2684.1 \text{ kJ/kg}$$

$$h_4 = h \text{ of saturated liquid at } 36.3 \text{ C} = 152 \text{ kJ/kg}$$

$$h_5 = h \text{ of saturated vapor at } 11.24 \text{ C} = 2522.2 \text{ kJ/kg}$$

$$w_1 = 0.4 \text{ kg/s}$$

$$w_2 + w_3 = w_1 = 0.4 \text{ kg/s}$$

$$w_1 x_1 = w_2 x_2$$

$$(0.4)(0.475) = w_2(0.6975)$$

$$w_2 = 0.2724 \text{ kg/s}$$

$$w_3 = 0.1276 \text{ kg/s}$$

$$q_g = w_3 h_3 + w_2 h_2 - w_1 h_1$$

$$q_g = (0.1276)(2684.1) + (0.2724)(-45) - (0.4)(-162) = 395 \text{ kW}$$

$$q_c = w_c h_3 - w_4 h_4$$

$$q_c = (0.1276)(2684.1 - 152) = 323 \text{ kW}$$

$$q_a = w_2 h_2 + w_5 h_5 - w_1 h_1$$

$$q_a = (0.2724)(-45) + (0.1276)(2522.2) - (0.4)(-162) = 374.4 \text{ kW}$$

$$q_e = w_5 h_5 - w_4 h_4$$

$$q_e = (0.1276)(2522.2 - 152) = 302.4 \text{ kW}$$

$$\text{COP}_{\text{abs}} = \frac{q_e}{q_g} = 0.766 \text{ (increase)}$$

New temperature of components:

$$\text{Generator} = 120 - (395 / 473.3)(120 - 100) = 103.3 \text{ C (increase)}$$

$$\text{Absorber} = 25 + (374.4 / 450.3)(30 - 25) = 29.2 \text{ C (decrease)}$$

$$\text{Condenser} = 25 + (323 / 371.2)(40 - 25) = 38.1 \text{ C (decrease)}$$

$$\text{Evaporator} = 15 - (302.4 / 348.2)(15 - 10) = 10.66 \text{ C (increase)}$$

With change in component temperature.

Fig. 17-5, 38.1 C condenser temperature, 103.3 C solution temperature

$$x_2 = 0.675 \text{ (increase)}$$

At 10.66 C evaporator temperature, 29.2 C solution temperature

$$x_1 = 0.4875 \text{ (decrease)}$$

Enthalpies: Fig. 17-8.

$$h_1 = h \text{ at } 29.2 \text{ C and } x \text{ of } 48.75 \% = -165 \text{ kJ/kg}$$

$$h_2 = h \text{ at } 103.3 \text{ C and } x \text{ of } 67.5 \% = -50 \text{ kJ/kg}$$

Enthalpies: Table A-1.

$$h_3 = h \text{ of saturated vapor at } 103.3 \text{ C} = 2681 \text{ kJ/kg}$$

$$h_4 = h \text{ of saturated liquid at } 38.1 \text{ C} = 159.5 \text{ kJ/kg}$$

$$h_5 = h \text{ of saturated vapor at } 10.66 \text{ C} = 2521 \text{ kJ/kg}$$

$$w_1 = 0.4 \text{ kg/s}$$

$$w_2 + w_3 = w_1 = 0.4 \text{ kg/s}$$

$$w_1 x_1 = w_2 x_2$$

$$(0.4)(0.4875) = w_2(0.675)$$

$$w_2 = 0.2889 \text{ kg/s}$$

$$w_3 = 0.1111 \text{ kg/s}$$

$$q_g = w_3 h_3 + w_2 h_2 - w_1 h_1$$

$$q_g = (0.1111)(2681) + (0.2889)(-50) - (0.4)(-165) = 349.4 \text{ kW}$$

$$q_c = w_c h_3 - w_4 h_4$$

$$q_c = (0.1111)(2681 - 159.5) = 280 \text{ kW}$$

$$q_a = w_2 h_2 + w_5 h_5 - w_1 h_1$$

$$q_a = (0.2889)(-50) + (0.1111)(2521) - (0.4)(-165) = 331.6 \text{ kW}$$

$$q_e = w_5 h_5 - w_4 h_4$$

$$q_e = (0.1111)(2521 - 159.5) = 262.4 \text{ kW}$$

$$\text{COP}_{\text{abs}} = \frac{q_e}{q_g} = 0.751 \text{ (increase)}$$

New temperature of components:

$$\text{Generator} = 120 - (349.4 / 473.3)(120 - 100) = 105.2 \text{ C (increase)}$$

$$\text{Absorber} = 25 + (331.6 / 450.3)(30 - 25) = 28.7 \text{ C (decrease)}$$

$$\text{Condenser} = 25 + (280 / 371.2)(40 - 25) = 36.3 \text{ C (decrease)}$$

$$\text{Evaporator} = 15 - (262.4 / 348.2)(15 - 10) = 11.23 \text{ C (increase)}$$

Take the average:

$$q_g = (1/2)(349.4 + 395.0) = 372.2 \text{ kW, } 104 \text{ C}$$

$$q_c = (1/2)(280 + 323) = 301.4 \text{ kW, } 37 \text{ C}$$

$$q_a = (1/2)(331.6 + 374.4) = 353 \text{ kW, } 29 \text{ C}$$

$$q_e = (1/2)(262.4 + 302.4) = 282.4 \text{ kW, } 11 \text{ C}$$

$$\text{Full load COP}_{\text{abs}} = 0.736$$

New COP_{abs}:

$$\text{COP}_{\text{abs}} = \frac{q_e}{q_g} = \frac{282.4}{372.2} = 0.759 \text{ (increase)}$$

$$\text{Reduction in } q_e = \frac{348.2 - 282.4}{348.2} = 0.189 \text{ or } 18.9\%$$

Therefore Capacity decrease by less than reduction in solution flow rate (33 1/3 %).

Table 17-1. Influence of reduction in solution flow rate of pump					
Component	Temperature	Solution concentrate		Refrigerating	COP(abs)
		x(gen)	x(abs)	Capacity	
Generator	"increase"	"increase"			
Absorber	"decrease"		"increase"		
Condenser	"decrease"				
Evaporator	"increase"			"decrease"	"increase"

(b) Initial:

$$\text{COP} = \frac{T_r (T_s - T_a)}{T_s (T_a - T_r)}$$

$$T_s = 100 \text{ C} + 273 = 373 \text{ K}$$

$$T_r = 10 \text{ C} + 273 = 283 \text{ K}$$

$$T_a = 1/2(30 \text{ C} + 40 \text{ C}) + 273 = 35 \text{ C} + 273 = 308 \text{ K}$$

$$\text{COP}_{\text{ideal}} = \frac{(283)(373 - 308)}{(373)(308 - 283)} = 1.973$$

$$\text{COP}_{\text{abs}} = 0.736$$

New:

$$T_s = 104 \text{ C} + 273 = 377 \text{ K}$$

$$T_r = 11 \text{ C} + 273 = 284 \text{ K}$$

$$T_a = 1/2(29 \text{ C} + 37 \text{ C}) + 273 = 33 \text{ C} + 273 = 306 \text{ K}$$

$$\text{COP}_{\text{ideal}} = \frac{(284)(377 - 306)}{(377)(306 - 284)} = 2.431 \text{ (increase)}$$

$$\text{COP}_{\text{abs}} = 0.759$$

Then:

$$\text{COP}_{\text{abs}} = 19.1913 \text{COP}_{\text{ideal}} - 12.683$$

$$\text{COP}_{\text{abs}} = 19.1913 \left[\frac{T_r(T_s - T_a)}{T_s(T_a - T_r)} \right] - 12.681$$

(1) COP_{abs} increases as T_s increases:

$$\text{COP}_{\text{abs}} = 19.1913 \left[\frac{T_r}{(T_a - T_r)} - \frac{T_a T_r}{T_s(T_a - T_r)} \right] - 12.681$$

(2) COP_{abs} increases as T_a decreases:

$$\text{COP}_{\text{abs}} = 19.1913 \left[\frac{T_r(T_s - T_r)}{T_s(T_a - T_r)} - \frac{T_r}{T_s} \right] - 12.681$$

(3) COP_{abs} increases as T_r increases:

$$\text{COP}_{\text{abs}} = 19.1913 \left[\frac{T_a(T_s - T_a)}{T_s(T_a - T_r)} - \frac{(T_s - T_a)}{T_s} \right] - 12.681$$

- 17-6. In the double-effect absorption unit shown in Fig. 17-14, LiBr-water solution leaves generator I with a concentration of 67 %, passes to the heat exchanger and then to generator II, where its temperature is elevated to 130 C. Next the solution passes through the throttling valve, where its pressure is reduced to that in the condenser, which is 5.62 kPa. In the process of the pressure reduction, some water vapor flashes off from this solution, flowing through generator II, (a) how much mass flashes to vapor. and (b) what is the concentration of LiBr-solution that drops into the condenser vessel?

Solution:

At 67 %, 130 C, Fig. 17.8

$$h_1 = -3.3 \text{ kJ/kg}$$

At 5.62 kPa

Try $t_2 = 100 \text{ C}$

$$h_2 = -55 \text{ kJ/kg solution, } x_2 = 68.4 \%$$

$$h_3 = 2676 \text{ kJ/kg water vapor}$$

$$w_1 = w_2 + w_3$$

$$w_1 x_1 = w_2 x_2$$

$$w_2 / w_1 = 0.67 / x_2$$

$$w_1 h_1 = w_2 h_2 + w_3 h_3$$

$$h_1 = (w_2/w_1)h_2 + (w_3/w_1)h_3$$

$$-3.3 = (0.67/x_2)(055) + (w_3/w_1)(2676)$$

$$w_1 = w_2 + w_3$$

$$1 = (w_2/w_1) + (w_3/w_1)$$

$$1 = (0.67/x_2) + (w_3/w_1)$$

$$-3.3 = (0.67/x_2)(-55) + (1 - 0.67/x_2)(2676)$$

$$0.67/x_2 = 0.9811$$

$$x_2 = 0.683 = 68.4 \%$$

(a) Mass flashes to vapor = w_3/w_1

$$w_3/w_1 = 1 - (0.67/x_2)$$

$$w_3/w_1 = 1 - (0.67 / 0.684)$$

$w_3/w_1 = 0.0205$ kg/kg of solution flowing through generator II - - Ans.

(b) $x_2 = 0.684 = 68.4 \%$ - - - Ans.

- 17-7. The combined absorption and vapor-compression system shown in Fig. 17-16 is to be provided with a capacity control scheme that maintains a constant temperature of the leaving chilled water as the temperature of the return water to be chilled varies. This control scheme is essentially one of reducing the refrigerating capacity. The refrigerant compressor is equipped with inlet valves (see Chap. 11), the speed of the turbine-compressor can be varied so long as it remains less than the maximum value of 180 r/s, and the control possibilities of the absorption unit are as described in Sec. 17-11. The characteristics of the steam turbine are that both its speed and power diminishes if the pressure of the supply steam decreases or the exhaust pressure increases. With constant inlet and exhaust pressures the speed of the turbine increases if the load is reduced. Devise a control scheme and describe the behavior of the entire system as the required refrigerating load decreases.

Answer:

1. If the return water to be chilled reduces, the refrigerating capacity will be reduced.
 2. For the refrigerating capacity reduced, the steam entering the generator of absorption unit will be throttled to reduce the generator temperature.
 3. For the vapor-compression unit, the compressor can be controlled by adjusting prerotation vane at the impeller inlet.
 4. For the entire system with the above control scheme, there is a possibility that the speed of turbine-compressor will increase greater than 180 r/s. So it is better to control only the exhaust pressure by increasing it then throttled before entering the generator of absorption unit. The refrigerating capacity and power diminishes as the exhaust pressure increases with constant supply steam.
- 17-8. The operating cost of an absorption system is to be compared with an electric-driven vapor-compression unit. The cost of natural gas on a heating value basis is \$4.20 per gigajoule, when used as fuel in a boiler it has a combustion efficiency of 75 percent. An absorption unit using steam from this boiler has a COP_{abs} of 0.73. If a vapor-compression unit is selected, the COP would be 3.4, and the electric motor efficiency is 85 percent. At what cost of electricity are the operating costs equal?

Solution:

Let q_e = refrigerating capacity = kWh

$$\begin{aligned} &\text{Operating cost of natural gas} \\ &= (\$4.20 / \text{GJ})(1 \text{ GJ} / 106 \text{ kJ})(3600 \text{ kJ} / 1 \text{ kWh})(q_e / 0.73)(1 / 0.75) \\ &= \$ 0.0276164q_e \end{aligned}$$

Let x = operating cost in cents / kWh

$$\begin{aligned} &\text{Operating cost of electric motor.} \\ &= (x / 100)(q_e) \end{aligned}$$

$$\begin{aligned} &\text{Then:} \\ &(x / 100)(q_e) = 0.0276164(q_e) \end{aligned}$$

$$\mathbf{x = 2.76 \text{ cents} / \text{kWh} \text{ --- Ans.}}$$

- 0 0 0 -

- 18-1. An air-source heat pump uses a compressor with the performance characteristics shown in Fig. 18-4. The evaporator has an air-side area of 80 m² and a U-value of 25 W/m².K. The airflow rate through the evaporator is 2 kg/s, and the condensing temperature is 40 C. Using the heat-rejection ratios of a hermetic compressor from Fig. 12-12, determine the heating capacity of the heat pump when the outdoor-air temperature is 0C.

Solution:

use Fig. 18-4 and Fig. 12-2.

Fig. 12-2 at 40 C Condensing temperature.

Evaporating Temperature, t _e	Heat-rejection ratio
10 C	1.19
0 C	1.255
-10 C	1.38

$$\text{Heat-rejection ratio} = 1.255 - 0.0095t_e + 0.0003t_e^2$$

Fig. 18-4. At outdoor air temperature = 0 C

Evaporating Temperature, t _e	Rate of evaporator heat transfer
-10 C	8.5 kw
0 C	12.9 kw
10 C	18.0 kw

$$\text{Rate of evaporator heat transfer} = 12.9 + 0.475t_e + 0.0035t_e^2$$

For evaporator, ambient = 0 C

$$\text{LMTD} = \frac{t_1 - t_2}{\ln\left(\frac{t_1 - t_e}{t_2 - t_e}\right)}$$

$$q_e = UALMTD$$

At 0 C, c_{pm} = 1.02 kJ/kg.K = 1020 J/kg.K say purely sensible.

$$q_e = wc_{pm}Dt = wc_{pm}(t_1 - t_2)$$

$$q_e = (2)(1020)(0 - t_2)$$

But,

$$q_e = (25)(80) \frac{(0 - t_2)}{\ln\left(\frac{0 - t_e}{t_2 - t_e}\right)}$$

Then,

$$\ln\left(\frac{0 - t_e}{t_2 - t_e}\right) = \frac{1}{1.02}$$

$$\frac{0 - t_e}{t_2 - t_e} = 2.6655$$

$$1.6644t_e = 2.6644t_2$$

$$t_2 = 0.624836t_e$$

$$q_e = (2)(1020)(0 - 0.624836t_e) / 1000 \text{ kW}$$

$$q_e = -1.274665t_e \text{ kW}$$

$$q_e = 12.9 + 0.475t_e + 0.0035t_e^2 = -1.274665t_e$$

$$0.0035t_e^2 + 1.749665t_e + 12.9 = 0$$

$$t_e = -7.485 \text{ C}$$

$$q_e = -1.274665(-7.485)$$

$$q_e = 9.541 \text{ kW}$$

$$\text{Heat-rejection ratio} = 1.255 - 0.0095(-7.485) + 0.0003(-7.485)^2$$

$$\text{Heat-rejection ratio} = 1.343$$

$$q_c = (1.343)(9.541)$$

$$q_c = 12.8 \text{ kW} \text{ --- Ans.}$$

- 18-2. The heat pump and structure whose characteristics are shown in Fig. 18-6 are in a region where the design outdoor temperature is -15 C. The compressor of the heat pump uses two cylinders to carry the base load and brings a third into service when needed. The third cylinder has a capacity equal to either of the other cylinders. How much supplementary resistance heat must be available at an outdoor temperature of -15 C?

Solution:

Use Fig. 18-6.

At -15 C

Heat loss of structure = 17.8 kW

Heating capacity = 8.0 kW

For two-cylinder = 8.0 kW

For three-cylinder = (3/2)(8.0 kW) = 12.0 kW

Supplementary resistance heat = 17.8 kW - 12.0 kW

= 5.8 kW --- Ans.

- 18-3. The air-source heat pump referred to in Figs. 18-4 and 18-5 operates 2500 h during the heating season, in which the average outdoor temperature is 5 C. The efficiency of the compressor motor is 80 percent, the motor for the outdoor air fan draws 0.7 kW, and the cost of electricity is 6 cents per kilowatt-hour. What is the heating cost for this season.

Solution:

Use Fig. 18-4 and Fig. 18-5.

Outdoor air temperature = 5 C.

Fig. 18-5

Heating capacity = 15.4 kW

Evaporator heat-transfer rate = 12 kW

Compressor Power = 3.4 kW

$$\begin{aligned} \text{Power to compressor motor} &= (3.4)(2500)(\$0.06) / (0.80) \\ &= \$ 637.50 \end{aligned}$$

Power to outdoor air fan motor = \$ 150.00

Heating Cost = \$ 637.50 + \$ 150.00 = **\$ 787.50 - - - Ans.**

- 18-4. A decentralized heat pump serves a building whose air-distribution system is divided into one interior and one perimeter zone. The system uses a heat rejector, water heater, and storage tank (with a water capacity of 60 m³) but no solar collector. The heat rejector comes into service when the temperature of the return-loop water reaches 32 C, and the boiler supplies supplementary heat when the return-loop water temperature drops to 15 C. Neither component operates when the loop water temperature is between 15 and 32 C. The heating and cooling loads of the different zones for two periods of a certain day as shown in Table 18-1. The loop water temperature is 15 C at the start of the day (7 A.M.). The decentralized heat pumps operate with COP of 3.0. Determine the magnitude of (a) the total heat rejection at the heat rejector from 7 A.M. to 6 P.M. and (b) the supplementary heat provided from 6 P.M. to 7 A.M.

	Interior zone		Perimeter zone	
	Heating, kW	Cooling, kW	Heating, kW	Cooling, kW
7 A.M. to 6 P.M.	-----	260	-----	40
6 P.M. to 7 A.M.	-----	50	320	-----

Solution:

Weight of water in storage tank.

$$V = 60 \text{ m}^3$$

$$\text{at } 24 \text{ C, } \rho = 997.4 \text{ kg/m}^3$$

$$w = (997.4)(60) = 59,884 \text{ kg}$$

Storage tank heat

$$= (59,884 \text{ kg})(4,190 \text{ kJ/kg.K})(32 - 15 \text{ K})$$

$$= 4.266 \text{ GJ}$$

(a) Heating time =

$$= \frac{4,265,537 \text{ kJ}}{(260 + 40 \text{ kW}) \left(\frac{1+3}{3} \right) (3600 \text{ s/h})}$$

$$= 2.962 \text{ hra}$$

$$\text{From 7 A.M. to 6 P.M.} = 11 \text{ hrs}$$

Total heat rejection

$$= (260 + 40 \text{ kW}) \left[\frac{1+3}{3} \right] (3600 \text{ s/h}) (11 - 2.962 \text{ hr})$$

$$= 11,574,720 \text{ kJ}$$

$$= \mathbf{11.6 \text{ GJ} - - - \text{Ans.}}$$

(b) Supplementary heat

$$\text{Storage tank heat} = 4,265,537 \text{ kJ}$$

$$\left(\text{Time} \right) \left[320 \left(\frac{3}{1+3} \right) - 50 \left(\frac{1+3}{3} \right) \text{ kW} \right] (3600 \text{ s/h}) = 4,265,537 \text{ kJ}$$

$$\text{Time} = 6.8358 \text{ hrs}$$

Supplementary heat

$$= \left[320 \left(\frac{3}{1+3} \right) - 50 \left(\frac{1+3}{3} \right) \text{ kw} \right] (3600 \text{ s/h})(13 - 6.8358 \text{ hr})$$

$$= 3,846,461 \text{ kJ}$$

= 3.85 GJ --- Ans.

- 18-5. The internal-source heat pump using the double-bundle heat pump shown in Fig. 18-9 is to satisfy a heating load of 335 kW when the outdoor temperature is -5 C, the return air temperature is 21 C, and the temperature of the cool supply air is 13 C. The minimum percentage of outdoor air specified for ventilation is 15 percent, and the flow rate of cool supply air is 40 kg/s. If the COP of the heat pump at this condition is 3.2, how much power must be provided by the supplementary heater?

Solution:

Outdoor air = -5 C, 15 % flow rate

Return air = 21 C

t_3 = Cool supply air = 13 C, $w = 40 \text{ kg/s}$

COP = 3.2

Heating Load = 335 kW

t_4 = mix temperature = $(0.15)(-5 \text{ C}) + (0.85)(21 \text{ C})$

$t_4 = 17.1 \text{ C}$

$q_e = wc_p(t_4 - t_3)$

$q_e = (40 \text{ kg/s})(1.0 \text{ kJ/kg.K})(17.1 \text{ C} - 13 \text{ C})$

$q_e = 164 \text{ kW}$

Condenser

$q_c = q_e(1 + \text{COP}) / \text{COP}$

$q_c = 164(1 + 3.2) / 3.2$

$q_c = 215.25 \text{ kW}$

Supplementary heat = $335 \text{ kW} - 215.25 \text{ kW}$

= 119.75 kW --- Ans.

- 0 0 0 -

- 19-1. Another rating point from the cooling tower catalog from which the data in Example 19-1 are taken specifies a reduction in water temperature from 33 to 27 C when the entering-air enthalpy is 61.6 kJ/kg. The water flow rate is 18.8 kg/s, and the air flow rate is 15.6 kg/s. Using a stepwise integration with 0.5-K increments of change in water temperature, compute $h_c A/c_{pm}$ for the tower.

Solution:

Eq. 19-4.

$$\frac{h_c A}{c_{pm}} = 4.19 L \Delta t \sum \frac{1}{(h_i - h_a)_m}$$

$$L = 18.8 \text{ kg/s}$$

$$G = 15.6 \text{ kg/s}$$

$$t_{in} = 33 \text{ C}$$

$$t_{out} = 27 \text{ C}$$

Use 12-section, 0.5 K water drop in each section.

Eq. 19-1

$$dq = g dh_a = L (4.19 \text{ kJ/kg.K}) dt \text{ kW}$$

$$\text{Entering air enthalpy} = 61.6 \text{ kJ/kg}$$

For section 0-1, 27 to 27.5 C

$$h_{a,1} - h_{a,0} = \frac{L}{G} 4.19 (0.5 \text{ K})$$

$$h_{a,0} = 61.6 \text{ kJ/kg}$$

$$h_{a,1} - 61.6 = \left(\frac{18.8}{15.6} \right) 4.19 (0.5 \text{ K}) = 2.53$$

$$h_{a,1} = 64.13 \text{ kJ/kg}$$

$$\text{Average } h_a = (1/2)(h_{a,0} + h_{a,1})$$

$$= (1/2)(61.6 + 64.13)$$

$$= 62.86 \text{ kJ/kg}$$

$$\text{Mean water temperature} = 27.25 \text{ C}$$

From Table A-2,

$$\text{Average } h_i = 86.44 \text{ kJ/kg}$$

$$(h_i - h_a)_m = 86.44 \text{ kJ/kg} - 62.86 \text{ kJ/kg}$$

$$= 23.58 \text{ kJ/kg}$$

Table

Section	Mean Water Temp., C	Average h_a , kJ/kg	Average h_i , kJ/kg	$(h_i - h_a)_m$ kJ/kg	$1/(h_i - h_a)_m$
0-1	27.25	62.86	86.44	23.58	0.04241
1-2	27.75	65.39	88.78	23.39	0.04275
2-3	28.25	67.92	91.18	23.26	0.043
3-4	28.75	70.45	93.63	23.18	0.04314
4-5	29.25	72.98	96.13	23.15	0.0432
5-6	29.75	75.51	98.7	23.19	0.04312
6-7	30.25	78.04	101.32	23.28	0.04296
7-8	30.75	80.57	104	23.43	0.04269
8-9	31.25	83.1	106.74	23.64	0.0423
9-10	31.75	85.63	109.54	23.91	0.04182
10-11	32.25	88.16	112.41	24.25	0.04124
11-12	32.75	90.69	115.35	24.66	0.04055

$$\sum \frac{1}{(h_i - h_a)_m} = 0.50917$$

Eq. 19-4.

$$\frac{h_c A}{c_{pm}} = 4.19(18.8)(0.5)(0.50917)$$

= 20.0 kW/(kJ/kg of enthalpy difference) - - - Ans.

19-2. Solve Prob. 19-1 using a compute program and 0.1-K increments of change of water temperature.

Solution:

Formula: $n = 0$ to 60

mean water temperature = $(1/2)(t_o + t_i)$

or = $(1/2)(t_n + t_{n+1})$ - - Eq. 1

Mean air enthalpy

$$\begin{aligned} h_{a,1} - h_{a,0} &= (L/G)(4.19)(0.1 \text{ K}) \\ &= (18.0 / 15.6)(4.19)(0.1) \\ &= 7.542 / 15.6 \end{aligned}$$

$$h_{a,0} = 61.6 \text{ kJ/kg}$$

$$h_{a,1} = h_{a,0} + 7.542/15.6$$

$$h_a = h_{a,0} + 3.771/15.6$$

$$h_a = h_{a,n} + 3.771/16.5 \text{ - - Eq. 2}$$

Mean h_i

Equation 19-5

$$h_i = 4.7926 + 2.568t - 0.029834t^2 + 0.0016657t^3 \text{ - - Eq. 3}$$

where t = mean water temperature

$$(h_i - h_a)m = \text{mean } h_i - \text{mean air enthalpy} \text{ --- Eq. 4}$$

Program; Microsoft Spreadsheet

Row 1:

A1 = "Water Temp. C"

C1 = "Mean Water Temp., C"

E1 = "Mean Air Enthalpy, kJ/kg"

F1 = "(h_i - h_a)m"

G1 = "1/(h_i - h_a)m"

Row 2:

A2 = "t_n"

B2 = "t_{n+1}"

Row 3:

A3 = 27

B3 = A3 + 0.1

C3 = (1/2)(A3 + B3)

D3 = 61.6 + 3.771/15.6

E3 = 4.7926 + 2.568*C3 - 0.029834*C3² + 0.0016657*C3³

F3 = E3 - D3

G3 = 1/F3

Row 4:

A4 = B3

B4 = A4 + 0.1

C4 = (1/2)(A4 + B3)

D4 = D3 + 7.542/15.6

E4 = 4.7926 + 2.568*C4 - 0.029834*C4² + 0.0016657*C4³

F4 = E4 - D4

G4 = 1/F4

Row 5:

A5 = B4

B5 = A5 + 0.1

C5 = (1/2)(A5 + B5)

D5 = D4 + 7.542/15.6

E5 = 4.7926 + 2.568*C5 - 0.029834*C5² + 0.0016657*C5³

F5 = E5 - D5

G5 = 1/F5

up to 62 rows

Row 62:

A62 = B61

B62 = A62 + 0.1

C62 = (1/2)(A62 + B62)

D62 = D61 + 7.542/15.6

E62 = 4.7926 + 2.568*C62 - 0.029834*C62² + 0.0016657*C62³

F62 = E62 - D62

G62 = 1/F62

CHAPTER 19 - COOLING TOWERS AND EVAPORATIVE CONDENSERS

Water Temp. C		Mean Water Temp. C	Mean Air Enthalpy, kJ/kg	Mean hi, kJ/kg	(hi - ha)m	1/(hi - ha)m
tn	tn+1					
27	27.1	27.05	61.841731	85.395843	23.554112	0.0424554
27.1	27.2	27.15	62.325192	85.857935	23.532742	0.042494
27.2	27.3	27.25	62.808654	86.322144	23.51349	0.0425288
27.3	27.4	27.35	63.292115	86.788479	23.496364	0.0425598
27.4	27.5	27.45	63.775577	87.256952	23.481375	0.0425869
27.5	27.6	27.55	64.259038	87.727571	23.468532	0.0426102
27.6	27.7	27.65	64.7425	88.200347	23.457847	0.0426297
27.7	27.8	27.75	65.225962	88.675289	23.449328	0.0426451
27.8	27.9	27.85	65.709423	89.152408	23.442985	0.0426567
27.9	28	27.95	66.192885	89.631714	23.43883	0.0426642
28	28.1	28.05	66.676346	90.113217	23.436871	0.0426678
28.1	28.2	28.15	67.159808	90.596926	23.437119	0.0426674
28.2	28.3	28.25	67.643269	91.082852	23.439583	0.0426629
28.3	28.4	28.35	68.126731	91.571005	23.444274	0.0426543
28.4	28.5	28.45	68.610192	92.061394	23.451202	0.0426417
28.5	28.6	28.55	69.093654	92.554031	23.460377	0.0426251
28.6	28.7	28.65	69.577115	93.048923	23.471808	0.0426043
28.7	28.8	28.75	70.060577	93.546083	23.485506	0.0425795
28.8	28.9	28.85	70.544038	94.045519	23.50148	0.0425505
28.9	29	28.95	71.0275	94.547241	23.519741	0.0425175
29	29.1	29.05	71.510962	95.051261	23.540299	0.0424803
29.1	29.2	29.15	71.994423	95.557587	23.563164	0.0424391
29.2	29.3	29.25	72.477885	96.066229	23.588345	0.0423938
29.3	29.4	29.35	72.961346	96.577198	23.615852	0.0423444
29.4	29.5	29.45	73.444808	97.090504	23.645697	0.042291
29.5	29.6	29.55	73.928269	97.606157	23.677887	0.0422335
29.6	29.7	29.65	74.411731	98.124166	23.712435	0.042172
29.7	29.8	29.75	74.895192	98.644541	23.749349	0.0421064
29.8	29.9	29.85	75.378654	99.167294	23.78864	0.0420369
29.9	30	29.95	75.862115	99.692432	23.830317	0.0419634
30	30.1	30.05	76.345577	100.21997	23.874391	0.0418859
30.1	30.2	30.15	76.829038	100.74991	23.920871	0.0418045
30.2	30.3	30.25	77.3125	101.28227	23.969768	0.0417192
30.3	30.4	30.35	77.795962	101.81705	24.021092	0.0416301
30.4	30.5	30.45	78.279423	102.35428	24.074852	0.0415371
30.5	30.6	30.55	78.762885	102.89394	24.131059	0.0414404
30.6	30.7	30.65	79.246346	103.43607	24.189722	0.0413399
30.7	30.8	30.75	79.729808	103.98066	24.250852	0.0412357
30.8	30.9	30.85	80.213269	104.52773	24.314458	0.0411278
30.9	31	30.95	80.696731	105.07728	24.380551	0.0410163
31	31.1	31.05	81.180192	105.62933	24.449141	0.0409012
31.1	31.2	31.15	81.663654	106.18389	24.520236	0.0407826
31.2	31.3	31.25	82.147115	106.74096	24.593849	0.0406606
31.3	31.4	31.35	82.630577	107.30056	24.669988	0.0405351
31.4	31.5	31.45	83.114038	107.8627	24.748663	0.0404062
31.5	31.6	31.55	83.5975	108.42739	24.829885	0.040274
31.6	31.7	31.65	84.080962	108.99463	24.913664	0.0401386
31.7	31.8	31.75	84.564423	109.56443	25.000008	0.04
31.8	31.9	31.85	85.047885	110.13681	25.08893	0.0398582
31.9	32	31.95	85.531346	110.71178	25.180438	0.0397134
32	32.1	32.05	86.014808	111.28935	25.274542	0.0395655
32.1	32.2	32.15	86.498269	111.86952	25.371253	0.0394147
32.2	32.3	32.25	86.981731	112.45231	25.47058	0.039261
32.3	32.4	32.35	87.465192	113.03773	25.572534	0.0391045
32.4	32.5	32.45	87.948654	113.62578	25.677124	0.0389452
32.5	32.6	32.55	88.432115	114.21648	25.78436	0.0387832
32.6	32.7	32.65	88.915577	114.80983	25.894253	0.0386186
32.7	32.8	32.75	89.399038	115.40585	26.006813	0.0384515
32.8	32.9	32.85	89.8825	116.00455	26.122049	0.0382818
32.9	33	32.95	90.365962	116.60593	26.239971	0.0381098
					SUM =	2.4810051

$$\sum \frac{1}{(h_i - h_a)_m} = 2.481$$

Eq. 19-4.

$$\frac{h_c A}{c_{pm}} = 4.19(18.8)(0.1)(2.481)$$

= 19.54 kW/(kJ/kg of enthalpy difference) - - - Ans.

19-3. If air enters the cooling tower in Prob. 19-1 with a dry-bulb temperature of 32 C, compute the dry-bulb temperatures as the air passes through the tower. For the stepwise calculation choose a change in water temperature of 0.5 K, for which the values of $1/(h_i - h_a)_m$ starting at the bottom section are, respectively, 0.04241, 0.04274, 0.04299, 0.04314, 0.04320, 0.04312, 0.04296, 0.04268, 0.04230, 0.04182, 0.04124, and 0.04055.

Solution: $t_{a,0} = 32$ C

For section 0-1

$$\frac{1}{(h_i - h_a)_m} = 0.04241$$

Dividing Eq. 19-7 by 2G.

$$\frac{h_c \Delta A}{2Gc_{pm}} = \frac{(4.19)(18.8)(0.5)(0.04241)}{(2)(15.6)} = 0.05354$$

From Eq. 19-6.

$$t_{a,1} = \frac{32.0 - (0.05354)(35.0 - 27 - 27.5)}{1 + 0.05354} = 31.36$$
 C

Tabulation:

n	section	$\frac{1}{(h_i - h_a)_m}$	$\frac{h_c \Delta A}{2Gc_{pm}}$	$t_{a,n+1}$
0	0-1	0.04241	0.05354	31.36
1	1-2	0.04274	0.05395	30.99
2	2-3	0.04299	0.05427	30.71
3	3-4	0.04314	0.05446	30.51
4	4-5	0.04320	0.05453	30.38
5	5-6	0.04312	0.05443	30.31
6	6-7	0.04296	0.05423	30.30
7	7-8	0.04268	0.05388	30.35
8	8-9	0.04230	0.05340	30.44
9	9-10	0.04182	0.05279	30.57
10	10-11	0.04124	0.05206	30.74
11	11-12	0.04055	0.05119	30.94

$t_{a,12} = 30.94$ C - - - Ans.

19-4. A crossflow cooling tower operating with a water flow rate of 45 kg/s and an airflow rate of 40 kg/s has a value of $h_c A/c_{pm} = 48$ kW/(kJ/kg of enthalpy difference). The enthalpy of the entering air is 80 kJ/kg, and the temperature of entering water is 36 C. Develop a computer program to predict the outlet water temperature when the tower is divided into 12 sections, as illustrated in Fig. 19-8.

Solution: Refer to Fig. 19-8.

Water flow rate = 45 kg/s
 Air flow rate = 40 kg/s

$$h_c A/c_{pm} = 48 \text{ kW}/(\text{kJ/kg of enthalpy difference})$$

$$t_{in} = 36 \text{ C}$$

$$h_{in} = 80 \text{ kJ/kg}$$

Table A-2 at 36 C
 $h_{i,in} = 136.16 \text{ kJ/kg}$

For section 1.
 $L = 45 / 4 = 11.25 \text{ kg/s}$
 $G = 40 / 3 = 13.33 \text{ kg/s} = 40/3 \text{ kg/s}$

$$(h_c A/c_{pm})/12 = 48/12 = 4.0 \text{ kW}/(\text{kJ/kg of enthalpy difference})$$

Eq. 19-8.

$$q = (11.25)(4.19)(t_{in} - t_1)$$

Eq. 19-9.

$$q = (40 / 3)(h_1 - h_{in})$$

Eq. 19-10.

$$q = \left(4 \frac{\text{kW}}{\text{kJ/kg}} \right) \left(\frac{h_{i,in} - h_{i,out}}{2} - \frac{h_{in} + h_1}{2} \right)$$

Combination of Eq. 19-9 and Eq. 19-10.

$$h_1 = \frac{Gh_{in} + [(h_c \Delta A/c_{pm})/2](136.16 + h_{i,out}t - h_{in})}{(h_c \Delta A/c_{pm})/2 + G}$$

Eq. 19-5

$$h_{i,out} = 4.7926 + 2.568t_1 - 0.029834t_1^2 + 0.0016657t_1^3$$

For section 1,

1. Eq. 19-5.
2. $h_{in} = 80 \text{ kJ/kg}$, $G = 40/3 \text{ kg/s}$
3. Combination of Eq. 19-9 and Eq. 19-10.
4. $q = (40 / 3)(h_1 - h_{in})$
5. $t_{in} = 36 \text{ C}$
6. $q = (11.25)(4.19)(t_{in} - t_1)$ solve for t_1

Then.

$$h_1 = \frac{Gh_{in} + [(h_c \Delta A/c_{pm})/2](136.16 + h_{i,out}t - h_{in})}{(h_c \Delta A/c_{pm})/2 + G}$$

$$h_1 = 76.8904 + 0.13044h_{i,out}$$

$$q = (40 / 3)(76.8904 + 0.13044h_{i,out} - 80)$$

$$q = -41.4613 + 1.7392h_{i,out}$$

$$t_1 = 36 - \frac{-41.4613 + 1.7392h_{i,out}}{(11.25)(4.19)}$$

$$t_1 = 36.8796 - 0.03690h_{i,out}$$

$$t_1 = 36.8796 - 0.03690(4.7926 + 2.568t_1 - 0.029834t_1^2 + 0.0016657t_1^3)$$

$$0.000061464t_1^3 - 0.001109t_1^2 + 1.09476t_1 - 36.7028 = 0$$

Try $t_1 = 32$ C

$$f(t_1) = 0.000061464t_1^3 - 0.001109t_1^2 + 1.09476t_1 - 36.7028 = -0.7920 < 0.0000$$

Try $t_1 = 33$ C

$$f(t_1) = 0.4254 > 0.0000$$

Try $t_1 = 32.5$ C, $f(t_1) = -0.1845 < 0.0000$

Try $t_1 = 32.6$ C, $f(t_1) = -0.0628 < 0.0000$

Try $t_1 = 32.7$ C, $f(t_1) = 0.0591 > 0.0000$

Try $t_1 = 32.65$ C, $f(t_1) = 0.0000 = 0.0000$

Then $t_1 = 32.65$ C

For computer program (Spreadsheet)

Table Data:

1. Section No.
2. Entering Water Temperature
3. Entering Air Enthalpy
4. Entering Enthalpy of Saturated Air
5. Leaving Water Temperature (Trial Value)
6. Leaving Air Enthalpy
7. Leaving Enthalpy of Saturated Air
8. Leaving Water Temperature (Actual Value)

Formula:

Section 1

Entering water temperature = t_{in}

Entering Air Enthalpy = h_{in}

$$h_1 = \frac{Gh_{in} + [(h_c \Delta A / c_{pm}) / 2] (h_{i,in} + h_{i,out} t - h_{in})}{(h_c \Delta A / c_{pm}) / 2 + G}$$

$$q = G(h_1 - h_{in})$$

$$q = G \left[\frac{Gh_{in} + [(h_c \Delta A / c_{pm}) / 2] (h_{i,in} + h_{i,out} t - h_{in})}{(h_c \Delta A / c_{pm}) / 2 + G} - h_{in} \right]$$

$$t_1 = t_{in} - \frac{q}{4.19L}$$

$$t_1 = t_{in} - \frac{G}{4.19L((h_c \Delta A / c_{pm}) / 2 + G)} \left[\frac{Gh_{in} + [(h_c \Delta A / c_{pm}) / 2] (h_{i,in} + h_{i,out} t - h_{in})}{(h_c \Delta A / c_{pm}) / 2 + G} - h_{in} \right]$$

$$t_1 = t_{in} - \frac{G((h_c \Delta A / c_{pm}) / 2)}{4.19L((h_c \Delta A / c_{pm}) / 2 + G)} (h_{i,in} + h_{i,out} - 2h_{in})$$

Eq. 19-5

$$h_{i,in} = 4.7926 + 2.568t_{in} - 0.029834t_{in}^2 + 0.0016657t_{in}^3$$

$$h_{i,out} = 4.7926 + 2.568t_{out} - 0.029834t_{out}^2 + 0.0016657t_{out}^3$$

Entering Values:

$$t_1 = t_{in} - \frac{\left(\frac{40}{3}\right)\left(\frac{4}{2}\right)}{4.19(11.25)\left(\frac{4}{2} + \frac{40}{3}\right)} (h_{i,in} + h_{i,out} - 2h_{in})$$

$$t_1 = t_{in} - \left(\frac{80}{2168.325}\right) (h_{i,in} + h_{i,out} - 2h_{in})$$

Subscript "in" is replaced in any section by subscript of its entering conditions.

Subscript "1" is replaced in any section by subscript of its leaving conditions.

Programming by spreadsheet:

Note.

1. Trial value should equal actual leaving water temperature in the Table by trial and error.
2. For sections 1, 2, 3 and 4, $t_{in} = 36$ C.
3. For section 1,5 and 9, $h_{in} = 80$ kJ/kg.

PROGRAM:

Row 1

A1 = "Section No."

B1 = "Entering Water Temp., C"

C1 = "Entering Air Enthalpy, kJ/kg"

D1 = "Entering Enthalpy of Saturated Air, kJ/kg"

E1 = "Leaving Water Temp., C (Trial)"

F1 = "Leaving Air Enthalpy, kJ/kg"

G1 = "Leaving Enthalpy of Saturated Air, kJ/kg"

H1 = "Leaving Water Temp., C (Actual)"

Row 2

A2 = 1

B2 = 36

C2 = 80

D2 = 4.7926 + 2.568*B2 - 0.029834*B2^2 + 0.0016657*B2^3

E2 = INPUT (Trial Value)

G2 = 4.7926 + 2.568*E2 - 0.029834*E2^2 + 0.0016657*E2^3

H2 = B2 - (80/2168.325)(G2 + D2 - 2*C2)

Row 3

A3 = A2 + 1

B3 = B2

C3 = F2

D3 = 4.7926 + 2.568*B3 - 0.029834*B3^2 + 0.0016657*B3^3

E3 = INPUT (Trial Value)

G3 = 4.7926 + 2.568*E3 - 0.029834*E3^2 + 0.0016657*E3^3

H3 = B3 - (80/2168.325)(G3 + D3 - 2*C3)

Row 4

A4 = A3 + 1

B4 = B2

$C4 = F3$
 $D4 = 4.7926 + 2.568*B4 - 0.029834*B4^2 + 0.0016657*B4^3$
 $E4 = \text{INPUT (Trial Value)}$
 $G4 = 4.7926 + 2.568*E4 - 0.029834*E4^2 + 0.0016657*E4^3$
 $H4 = B4 - (80/2168.325)(G4 + D4 - 2*C4)$
 Row 5
 $A5 = A4 + 1$
 $B5 = B2$
 $C5 = F4$
 $D5 = 4.7926 + 2.568*B5 - 0.029834*B5^2 + 0.0016657*B5^3$
 $E5 = \text{INPUT (Trial Value)}$
 $G5 = 4.7926 + 2.568*E5 - 0.029834*E5^2 + 0.0016657*E5^3$
 $H5 = B5 - (80/2168.325)(G5 + D5 - 2*C5)$
 Row 6
 $A6 = A5 + 1$
 $B6 = H2$
 $C6 = 80$
 $D6 = 4.7926 + 2.568*B6 - 0.029834*B6^2 + 0.0016657*B6^3$
 $E6 = \text{INPUT (Trial Value)}$
 $G6 = 4.7926 + 2.568*E6 - 0.029834*E6^2 + 0.0016657*E6^3$
 $H6 = B6 - (80/2168.325)(G6 + D6 - 2*C6)$
 Row 7
 $A7 = A6 + 1$
 $B7 = H3$
 $C7 = F6$
 $D7 = 4.7926 + 2.568*B7 - 0.029834*B7^2 + 0.0016657*B7^3$
 $E7 = \text{INPUT (Trial Value)}$
 $G7 = 4.7926 + 2.568*E7 - 0.029834*E7^2 + 0.0016657*E7^3$
 $H7 = B7 - (80/2168.325)(G7 + D7 - 2*C7)$
 Row 8
 $A8 = A7 + 1$
 $B8 = H4$
 $C8 = F7$
 $D8 = 4.7926 + 2.568*B8 - 0.029834*B8^2 + 0.0016657*B8^3$
 $E8 = \text{INPUT (Trial Value)}$
 $G8 = 4.7926 + 2.568*E8 - 0.029834*E8^2 + 0.0016657*E8^3$
 $H8 = B8 - (80/2168.325)(G8 + D8 - 2*C8)$
 Row 9
 $A9 = A8 + 1$
 $B9 = H5$
 $C9 = F8$
 $D9 = 4.7926 + 2.568*B9 - 0.029834*B9^2 + 0.0016657*B9^3$
 $E9 = \text{INPUT (Trial Value)}$
 $G9 = 4.7926 + 2.568*E9 - 0.029834*E9^2 + 0.0016657*E9^3$
 $H9 = B9 - (80/2168.325)(G9 + D9 - 2*C9)$
 Row 10
 $A10 = A9 + 1$
 $B10 = H6$
 $C10 = 80$
 $D10 = 4.7926 + 2.568*B10 - 0.029834*B10^2 + 0.0016657*B10^3$
 $E10 = \text{INPUT (Trial Value)}$
 $G10 = 4.7926 + 2.568*E10 - 0.029834*E10^2 + 0.0016657*E10^3$
 $H10 = B10 - (80/2168.325)(G10 + D10 - 2*C10)$
 Row 11
 $A11 = A10 + 1$
 $B11 = H7$

$C11 = F10$
 $D11 = 4.7926 + 2.568*B11 - 0.029834*B11^2 + 0.0016657*B11^3$
 $E11 = \text{INPUT (Trial Value)}$
 $G11 = 4.7926 + 2.568*E11 - 0.029834*E11^2 + 0.0016657*E11^3$
 $H11 = B11 - (80/2168.325)(G11 + D11 - 2*C11)$
 Row 12
 $A12 = A11 + 1$
 $B12 = H8$
 $C12 = F11$
 $D12 = 4.7926 + 2.568*B12 - 0.029834*B12^2 + 0.0016657*B12^3$
 $E12 = \text{INPUT (Trial Value)}$
 $G12 = 4.7926 + 2.568*E12 - 0.029834*E12^2 + 0.0016657*E12^3$
 $H12 = B12 - (80/2168.325)(G12 + D12 - 2*C12)$
 Row 13
 $A13 = A12 + 1$
 $B13 = H9$
 $C13 = F12$
 $D13 = 4.7926 + 2.568*B13 - 0.029834*B13^2 + 0.0016657*B13^3$
 $E13 = \text{INPUT (Trial Value)}$
 $G13 = 4.7926 + 2.568*E13 - 0.029834*E13^2 + 0.0016657*E13^3$
 $H13 = B13 - (80/2168.325)(G13 + D13 - 2*C13)$

Output:

Section No.	Entering Water Temp., C	Entering Air Enthalpy, kJ/kg	Entering Enthalpy of Saturated Air, kJ/kg	Leaving Water Temp., C (Trial)	Leaving Air Enthalpy, kJ/kg	Leaving Enthalpy of Saturated Air, kJ/kg	Leaving Water Temp., C (Actual)
1	36.0000	80.0000	136.2906	32.6409	91.8755	114.7557	32.6409
2	36.0000	91.8755	136.2906	33.3574	101.2179	119.0839	33.3575
3	36.0000	101.2179	136.2906	33.9182	108.5777	122.5695	33.9182
4	36.0000	108.5777	136.2906	34.3581	114.3823	125.3649	34.3582
5	32.6409	80.0000	114.7555	30.5199	87.4983	102.7312	30.5199
6	33.3575	87.4983	119.0843	31.4423	94.2689	107.8193	31.4424
7	33.9182	94.2689	122.5697	32.2114	100.3031	112.2270	32.2115
8	34.3582	100.3031	125.3654	32.8534	105.6230	116.0250	32.8534
9	30.5199	80.0000	102.7312	29.114	84.9703	95.3750	29.1140
10	31.4424	84.9703	107.8196	30.0389	89.9319	100.1613	30.0389
11	32.2115	89.9319	112.2277	30.8503	94.7443	104.5294	30.8503
12	32.8534	94.7443	116.0252	31.5611	99.3131	108.4902	31.5611

- 000 -

20-1. Using Eq. 20-3, compute the hour of sunrise on the shortest day of the year of 40° north latitude.

Solution: Eq. 20-3

$$\sin \beta = \cos L \cos H \cos \delta + \sin L \sin \delta$$

H = hour angle = 15 degrees per one hour from solar noon.

$$L = 40^\circ$$

$\beta = 0^\circ$ - solar altitude at sunrise

$\delta = -23.5^\circ$ - shortest day on winter solstice

$$\sin 0 = \cos 40 \cos H \cos (-23.5) + \sin 40 \sin (-23.5)$$

$$H = 68.6^\circ$$

or $68.6 / 15 = 4.573333$ hrs from noon

= 12 - 4.573333

= 7.426667 from midnight

= **7:26 A.M. - - - Ans.**

20-2. Compute the solar azimuth angle at 32° north latitude on February 21.

Solution: From Table 4-13

Solar Time A.M.	β	ϕ
7	7	73
8	18	64
9	29	53
10	38	39
11	45	21
12	47	0

β = solar altitude

ϕ = solar azimuth

Eq. 20-4

$$\sin \phi = \frac{\cos \delta \sin H}{\cos \beta}$$

for $\phi \leq 90^\circ$

Eq. 20-3.

$$\sin \beta = \cos L \cos H \cos \delta + \sin L \sin \delta$$

L = latitude = 32°

H = Hour Angle

δ = Declination angle

For February 21

$$N = 31 + 21 = 52$$

Eq. 20-2.

$$\delta = 23.47 \sin \frac{360(284 + N)}{365}$$

$$\delta = 23.47 \sin \frac{360(284 + 52)}{365}$$

$$\delta = -11.24^\circ$$

$$\sin \beta = \cos L \cos H \cos \delta + \sin L \sin \delta$$

$$\sin \beta = \cos 32 \cos H \cos (-11.24) + \sin 32 \sin (-11.24)$$

$$\sin \beta = 0.83178 \cos H - 0.10329$$

$$\sin \phi = \frac{\cos \delta \sin H}{\cos \beta}$$

$$\sin \phi = \frac{\cos(-11.24) \sin H}{\cos \beta}$$

$$\phi = \text{Arcsin} \left(\frac{0.98082 \sin H}{\cos \beta} \right)$$

Then: $H = 15^\circ \times$ (No. of hours from Noon)

Ans.

Tabulation

Solar Time, A.M.	H	β	ϕ
7	75	6.43	72.44
8	60	18.22	63.41
9	45	29.00	52.46
10	30	38.10	38.55
11	15	44.44	20.83
12	0	46.76	0.00

- 20-3. (a) What is the angle of incidence of the sun's rays with a south-facing roof that is sloped at 45° with the horizontal at 8 A.M. on June 21 at a latitude of 40° north? (b) What is the compass direction of the sun at this time?

Solution:

$$S = 45^\circ$$

$$L = 40^\circ$$

At 8 A.M.

$$H = 4 \times 15 = 60^\circ$$

$$\text{On June 21, } \delta = 23.5^\circ$$

(a) Eq. 20-3.

$$\sin \beta = \cos L \cos H \cos \delta + \sin L \sin \delta$$

$$\sin \beta = \cos 40 \cos 60 \cos 23.5 + \sin 40 \sin 23.5$$

$$\beta = 37.41$$

$$\sin \phi = \frac{\cos \delta \sin H}{\cos \beta}$$

$$\sin \phi = \frac{\cos 23.5 \sin 60}{\cos 37.41}$$

$$\phi = 30.83$$

Table 4-13, $\phi > 90$

$$\phi = 180 - 89.04 = 90.96$$

$$\gamma = \phi \pm \varphi$$

$$\varphi = 0$$

$$\gamma = 90.96 - 0 = 90.96$$

Eq. 20-8.

$$\cos \theta = \cos \beta \cos \gamma \sin \Sigma + \sin \beta \cos \Sigma$$

$$\cos \theta = \cos 37.41 \cos 90.96 \sin 45 + \sin 37.41 \cos 45$$

$$\theta = 65^\circ \text{ --- Ans.}$$

(b) Compass direction = 65° SE ---- Ans.

20-4. As an approach to selecting the tilt angle Σ of a solar collector a designer chooses the sum of $I_{DN} \cos \theta$ at 10 A.M. and 12 noon on January 21 as the criterion on which to optimize the angle. At 40° north latitude, with values of $A = 1230 \text{ W/m}^2$ and $B = 0.14$ in Eq. (20-9), what is the optimum tilt angle?

Solution:

Eq. 20-9.

$$I_{DN} = \frac{A}{\exp(B/\sin \beta)}$$

$$A = 1230 \text{ W/m}^2$$

$$B = 0.14$$

$$L = 40^\circ$$

At 10 A.M. January 21.

$$\delta = 23.47 \sin \frac{360(284 + N)}{365}$$

$$N = 21$$

$$\delta = 23.47 \sin \frac{360(284 + 21)}{365} = -20.16$$

$$H = 2 \times 15 = 30$$

$$\sin \beta = \cos L \cos H \cos \delta + \sin L \sin \delta$$

$$\sin \beta = \cos 40 \cos 30 \cos (-20.16) + \sin 40 \sin (-20.16)$$

$$\beta = 23.66$$

$$\sin \phi = \frac{\cos \delta \sin H}{\cos \beta}$$

$$\sin \phi = \frac{\cos(-20.16) \sin 30}{\cos 23.66}$$

$$\phi = 30.83$$

At 12 NOON January 21.

$$\delta = 23.47 \sin \frac{360(284 + N)}{365}$$

$$N = 21$$

$$\delta = 23.47 \sin \frac{360(284 + 21)}{365} = -20.16$$

$$H = 0 \times 15 = 0$$

$$\sin \beta = \cos L \cos H \cos \delta + \sin L \sin \delta$$

$$\sin \beta = \cos 40 \cos 0 \cos (-20.16) + \sin 40 \sin (-20.16)$$

$$\beta = 29.84$$

$$\sin \phi = \frac{\cos \delta \sin H}{\cos \beta}$$

$$\sin\phi = \frac{\cos(-20.16)\sin 0}{\cos 29.84}$$

$$\phi = 0.0$$

Then,

At 10 A.M., $\beta = 23.66$, $\phi = 30.83$

At 12 N.N., $\beta = 29.84$, $\phi = 0.0$

Eq. 20-8.

$$\cos \theta = \cos \beta \cos \gamma \sin \Sigma + \sin \beta \cos \Sigma$$

Then $\cos \gamma = \cos \phi$

Substitute in Eq. 20-9.

At 10 A.M.

$$I_{DN} \cos \theta = \frac{A(\cos \beta \cos \gamma \sin \Sigma + \sin \beta \cos \Sigma)}{\exp(B/\sin \beta)}$$

$$I_{DN} \cos \theta = \frac{(1230)(\cos(23.66)\cos(30.83)\sin \Sigma + \sin(23.66)\cos \Sigma)}{\exp(0.14/\sin(23.66))}$$

$$I_{DN} \cos \theta = \frac{(1230)(0.786513\sin \Sigma + 0.401308\cos \Sigma)}{1.417449}$$

$$I_{DN} \cos \theta = 682.502\sin \Sigma + 348.238\cos \Sigma$$

At 12 NN.

$$I_{DN} \cos \theta = \frac{A(\cos \beta \cos \gamma \sin \Sigma + \sin \beta \cos \Sigma)}{\exp(B/\sin \beta)}$$

$$I_{DN} \cos \theta = \frac{(1230)(\cos(29.84)\cos(0.0)\sin \Sigma + \sin(29.84)\cos \Sigma)}{\exp(0.14/\sin(29.84))}$$

$$I_{DN} \cos \theta = \frac{(1230)(0.867418\sin \Sigma + 0.497580\cos \Sigma)}{1.324933}$$

$$I_{DN} \cos \theta = 805.266\sin \Sigma + 461.928\cos \Sigma$$

Total:

$$T = (682.502 + 805.26)\sin \Sigma + (348.238 + 461.928)\cos \Sigma$$

$$T = 1487.77\sin \Sigma + 810.166\cos \Sigma$$

Differentiate then equate to zero.

$$T' = 1487.77\cos \Sigma - 810.166\sin \Sigma = 0$$

$$\tan \Sigma = \frac{1487.77}{810.166}$$

$$\Sigma = 61.43^\circ \text{ --- Ans.}$$

20-5. Plot the efficiency of the collector described in Example 20-3 versus temperature of fluid entering the absorber over the range of 30 to 140 C fluid temperatures. The ambient temperature is 10 C. If the collector is being irradiated at 750 W/m^2 , determine the rate of collection at entering fluid temperatures at (a) 50 C and (b) 100 C.

Solution: Refer to Example 20-3.

$$t_\infty = 10\text{C}$$

$$t_{\text{ai}} = 30 \text{ to } 140 \text{ C}$$

$$I_{i0} = 800 \text{ W/m}^2$$

$$Fr = 0.90$$

$$\alpha_a = 0.90$$

$$\tau_{c1} = \tau_{c2} = 0.87$$

Eq. 20-12.

$$\eta = \frac{q_a/A}{I_{i0}} = \left(\tau_{c1}\tau_{c2}\alpha_a - \frac{(t_{ai} - t_{\infty})U}{I_{i0}} \right) Fr$$

$$\eta = \left((0.87)(0.87)(0.9) - \frac{(t_{ai} - 10)3.5}{800} \right) (0.9)$$

Tabulation:

t_{ai}	η
30	0.534
40	0.495
50	0.456
60	0.416
70	0.377
80	0.338
90	0.298
100	0.259
110	0.219
120	0.180
130	0.140
140	0.101

Plot:

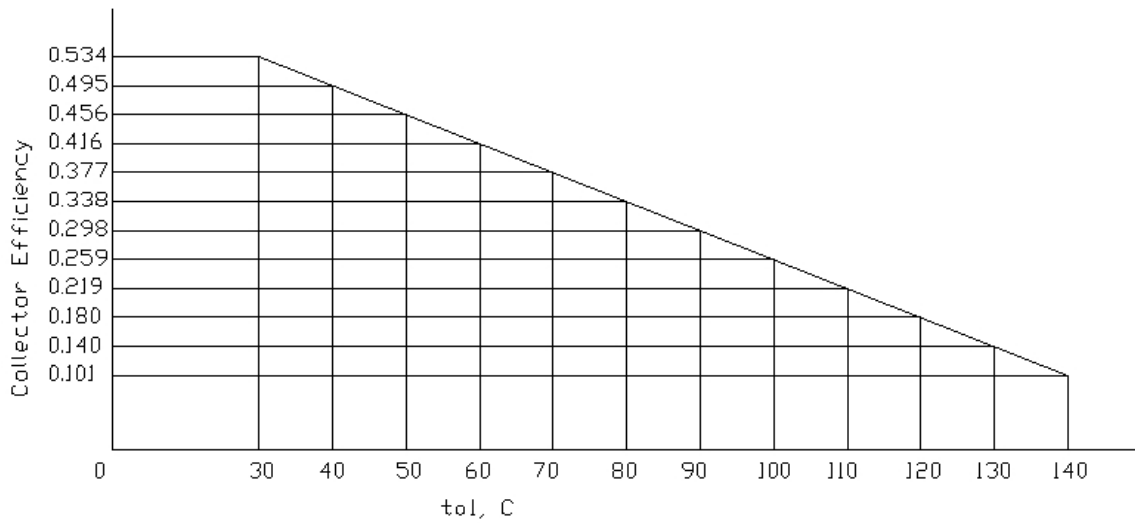

(a) At 50 C, $I_{i0} = 750 \text{ W/m}^2$

$$q_a/A = (I_{i0}\tau_{c1}\tau_{c2}\alpha_a - U(t_{ai} - t_{\infty}))Fr$$

$$q_a/A = [(750)(0.87)(0.87)(0.9) - (3.5)(50 - 10)](0.9)$$

$$q_a/A = 334 \text{ W/m}^2 \text{ --- Ans.}$$

(a) At 100 C, $I_{i0} = 750 \text{ W/m}^2$

$$q_a/A = (I_{i0} \tau_{c1} \tau_{c2} \alpha_a - U(t_{ai} - t_{\infty})) Fr$$

$$q_a/A = [(750)(0.87)(0.87)(0.9) - (3.5)(100 - 10)](0.9)$$

$$q_a/A = 176 \text{ W/m}^2 \text{ --- Ans.}$$

20-6. A 1.25- by 2.5-m flat-plate collector receives solar irradiation at a rate of 900 W/m². It has a single cover plate with $\tau = 0.9$, and the absorber has an absorptivity of $\alpha_a = 0.9$. Experimentally determined values are $Fr = 0.9$ and $U = 6.5 \text{ W/m}^2 \cdot \text{K}$. The cooling fluid is water. If the ambient temperature is 32 C and the fluid temperature is 60 C entering the absorber, what are (a) the collector efficiency, (b) the fluid outlet temperature for a flow rate of 25 kg/h, and (c) the inlet temperature to the absorber at which output drops to zero?

Solution:

(a) Eq. 20-12.

$$\eta = \left(\tau_{c1} \tau_{c2} \alpha_a - \frac{(t_{ai} - t_{\infty}) U}{I_{i0}} \right) Fr$$

$$\tau_{c1} = \tau_{c2} = 0.90$$

$$\alpha_a = 0.90$$

$$Fr = 0.90$$

$$U = 6.5 \text{ W/m}^2 \cdot \text{K}$$

$$\eta = \left((0.9)(0.9) - \frac{(60 - 32)3.5}{900} \right) (0.9)$$

$$\eta = 0.701 \text{ --- Ans.}$$

(b)

$$\eta = \frac{q_a/A}{I_{i0}}$$

$$A = 1.25 \times 2.5 = 3.125 \text{ m}^2$$

$$I_{i0} = 900 \text{ W/m}^2$$

$$\eta = 0.701$$

$$q_a = \eta I_{i0} A$$

$$q_a = (0.701)(900)(3.125)$$

$$q_a = 1972 \text{ W}$$

$$q_a = w c_p (t_{ao} - t_{ai})$$

$$w = 25 \text{ kg/s}$$

$$c_p = 4190 \text{ J/kg} \cdot \text{K}$$

$$1972 = (25)(4190)(t_{ao} - 60)$$

$t_{ao} = 127.8 \text{ C} \text{ --- Ans.}$

(c) If $q_a = 0$

Eq. 20-11

$$q_a/A = 0 = (I_{i0} \tau_{c1} \tau_{c2} \alpha_a - U(t_{ai} - t_{\infty}))Fr$$

$$0 = ((900)(0.9)(0.9) - (6.5)(t_{ai} - 32))0.9$$

$t_{ai} = 144.2 \text{ C} \text{ --- Ans.}$

20-7. Two architects have different notions of how to orient windows on the west side of a building in order to be most effective from a solar standpoint-summer and winter. The windows are double-glazed. The two design are shown in Fig. 20-15. Compute at 40° north latitude the values of I_T from Eq. (20-14) for June 21 at 2 and 6 P.M. and January 21 at 2 P.M. and then evaluate the pros and cons of the two orientations. See Fig. 20-15.

Solution:

Eq. 20-14

$$I_T = I_{DN} (\cos \phi) \tau$$

(a) For notion (a).

At 40° north latitude, June 21 at 2 P.M.

$$\delta = 23.5^\circ$$

$$H = 2 \times 15 = 30^\circ$$

$$L = 40^\circ$$

Eq. 20-3

$$\sin \beta = \cos L \cos H \cos \delta + \sin L \sin \delta$$

$$\sin \beta = \cos 40 \cos 30 \cos 23.5 + \sin 40 \sin 23.5$$

$$\beta = 59.85$$

Eq. 20-4

$$\sin \phi = \frac{\cos \delta \sin H}{\cos \beta}$$

$$\sin \phi = \frac{\cos 23.5 \sin 30}{\cos 59.85}$$

$$\phi = 65.91$$

Eq. 20-8.

$$\cos \theta = \cos \beta \cos \gamma \sin \Sigma + \sin \beta \cos \Sigma$$

$$\Sigma = \text{tilt angle} = 30$$

For facing west, Eq. 20-6.

$$\gamma = \phi \pm \varphi$$

$$\varphi = 60$$

$$\gamma = 65.91 - 60 = 5.91$$

$$\cos \theta = \cos 59.85 \cos 5.91 \sin 30 + \sin 59.85 \cos 30$$

$$\cos \theta = 0.99866$$

$$\theta = 87$$

Fig. 20-6, Double Glazing

$$\tau = 0.11$$

$$I_T = I_{DN} (\cos\phi)\tau$$

$$I_{DN} = \frac{A}{\exp\left(\frac{B}{\sin\beta}\right)}$$

A = 1080 W/m² in Mid-summer

B = 0.21 in summer

$$I_T = \frac{(1080)(0.99866)(0.11)}{\exp\left(\frac{0.21}{\sin 59.85}\right)}$$

$$I_T = 93.06 \text{ W/m}^2$$

40° north latitude, June 21, 6 P.M.

$$\delta = 23.5^\circ$$

$$H = 6 \times 15 = 90^\circ$$

$$L = 40^\circ$$

Eq. 20-3

$$\sin \beta = \cos L \cos H \cos \delta + \sin L \sin \delta$$

$$\sin \beta = \cos 40 \cos 90 \cos 23.5 + \sin 40 \sin 23.5$$

$$\beta = 14.85$$

Eq. 20-4

$$\sin\phi = \frac{\cos\delta\sin H}{\cos\beta}$$

$$\sin\phi = \frac{\cos 23.5 \sin 90}{\cos 14.85}$$

$$\phi = 71.58$$

But Table 4-13,

$$\phi > 90$$

$$\phi = 180 - 71.58 = 108.42$$

Eq. 20-8.

$$\cos \theta = \cos \beta \cos \gamma \sin \Sigma + \sin \beta \cos \Sigma$$

$$\Sigma = \text{tilt angle} = 30$$

For facing west, Eq. 20-6.

$$\gamma = \phi \pm \varphi$$

$$\varphi = 60$$

$$\gamma = 108.42 - 60 = 48.42$$

$$\cos \theta = \cos 14.85 \cos 48.42 \sin 30 + \sin 14.85 \cos 30$$

$$\cos \theta = 0.542703$$

$$\theta = 57.13$$

Fig. 20-6, Double Glazing

$$\tau = 0.68$$

$$I_T = I_{DN} (\cos\phi)\tau$$

$$I_{DN} = \frac{A}{\exp\left(\frac{B}{\sin\beta}\right)}$$

A = 1080 W/m² in Mid-summer
 B = 0.21 in summer

$$I_T = \frac{(1080)(0.542703)(0.68)}{\exp\left(\frac{0.21}{\sin 14.85^\circ}\right)}$$

$$I_T = 175.65 \text{ W/m}^2$$

At 40° north latitude, January 21 at 2 P.M.

$$\delta = 23.47 \sin \frac{360(284 + N)}{365}$$

$$N = 21$$

$$\delta = 23.47 \sin \frac{360(284 + 21)}{365} = -20.16$$

$$\delta = -20.16^\circ$$

$$H = 2 \times 15 = 30^\circ$$

$$L = 40^\circ$$

Eq. 20-3

$$\sin \beta = \cos L \cos H \cos \delta + \sin L \sin \delta$$

$$\sin \beta = \cos 40 \cos 30 \cos (-20.16) + \sin 40 \sin (-20.16)$$

$$\beta = 23.66$$

Eq. 20-4

$$\sin \phi = \frac{\cos \delta \sin H}{\cos \beta}$$

$$\sin \phi = \frac{\cos(-20.6) \sin 30}{\cos 23.66}$$

$$\phi = 30.83$$

Eq. 20-8.

$$\cos \theta = \cos \beta \cos \gamma \sin \Sigma + \sin \beta \cos \Sigma$$

$$\Sigma = \text{tilt angle} = 30$$

For facing west, Eq. 20-6.

$$\gamma = \phi \pm \varphi$$

$$\varphi = 60$$

$$\gamma = 30.83 - 60 = -29.17$$

$$\cos \theta = \cos 23.66 \cos (-29.17) \sin 30 + \sin 23.66 \cos 30$$

$$\cos \theta = 0.747434$$

$$\theta = 41.63$$

Fig. 20-6, Double Glazing

$$\tau = 0.76$$

$$I_T = I_{DN} (\cos \phi) \tau$$

$$I_{DN} = \frac{A}{\exp\left(\frac{B}{\sin\beta}\right)}$$

A = 1230 W/m² in December and January
B = 0.14 in summer

$$I_T = \frac{(1230)(0.747434)(0.76)}{\exp\left(\frac{0.14}{\sin 23.66}\right)}$$

$$I_T = 493 \text{ W/m}^2$$

Then:

June 21, 2 P.M. $I_T = 93.06 \text{ W/m}^2$

June 21, 6 P.M. $I_T = 175.65 \text{ W/m}^2$

January 21, 2 P.M. $I_T = 493 \text{ W/m}^2$

(b) For notion (b).

At 40° north latitude, June 21 at 2 P.M.

$$\delta = 23.5^\circ$$

$$H = 2 \times 15 = 30^\circ$$

$$L = 40^\circ$$

Eq. 20-3

$$\sin \beta = \cos L \cos H \cos \delta + \sin L \sin \delta$$

$$\sin \beta = \cos 40 \cos 30 \cos 23.5 + \sin 40 \sin 23.5$$

$$\beta = 59.85$$

Eq. 20-4

$$\sin \phi = \frac{\cos \delta \sin H}{\cos \beta}$$

$$\sin \phi = \frac{\cos 23.5 \sin 30}{\cos 59.85}$$

$$\phi = 65.91$$

Eq. 20-8.

$$\cos \theta = \cos \beta \cos \gamma \sin \Sigma + \sin \beta \cos \Sigma$$

$$\Sigma = \text{tilt angle} = -30$$

For facing west, Eq. 20-6.

$$\gamma = \phi \pm \varphi$$

$$\varphi = 60$$

$$\gamma = 65.91 - 60 = 5.91$$

$$\cos \theta = \cos 59.85 \cos 5.91 \sin (-30) + \sin 59.85 \cos (-30)$$

$$\cos \theta = 0.499066$$

$$\theta = 60.06$$

Fig. 20-6, Double Glazing

$$\tau = 0.65$$

$$I_T = I_{DN} (\cos\phi)\tau$$

$$I_{DN} = \frac{A}{\exp\left(\frac{B}{\sin\beta}\right)}$$

A = 1080 W/m² in Mid-summer

B = 0.21 in summer

$$I_T = \frac{(1080)(0.499066)(0.65)}{\exp\left(\frac{0.21}{\sin 59.85}\right)}$$

$$I_T = 274.8 \text{ W/m}^2$$

40° north latitude, June 21, 6 P.M.

$$\delta = 23.5^\circ$$

$$H = 6 \times 15 = 90^\circ$$

$$L = 40^\circ$$

Eq. 20-3

$$\sin \beta = \cos L \cos H \cos \delta + \sin L \sin \delta$$

$$\sin \beta = \cos 40 \cos 90 \cos 23.5 + \sin 40 \sin 23.5$$

$$\beta = 14.85$$

Eq. 20-4

$$\sin\phi = \frac{\cos\delta\sin H}{\cos\beta}$$

$$\sin\phi = \frac{\cos 23.5 \sin 90}{\cos 14.85}$$

$$\phi = 71.58$$

But Table 4-13,

$$\phi > 90$$

$$\phi = 180 - 71.58 = 108.42$$

Eq. 20-8.

$$\cos \theta = \cos \beta \cos \gamma \sin \Sigma + \sin \beta \cos \Sigma$$

$$\Sigma = \text{tilt angle} = -30$$

For facing west, Eq. 20-6.

$$\gamma = \phi \pm \varphi$$

$$\varphi = 60$$

$$\gamma = 108.42 - 60 = 48.42$$

$$\cos \theta = \cos 14.85 \cos 48.42 \sin (-30) + \sin 14.85 \cos (-30)$$

$$\cos \theta = -0.0988$$

$$\theta = 95.67 > 90$$

Therefore

$$I_T = 0.00 \text{ W/m}^2$$

At 40° north latitude, January 21 at 2 P.M.

$$\delta = 23.47 \sin \frac{360(284 + N)}{365}$$

$$N = 21$$

$$\delta = 23.47 \sin \frac{360(284 + 21)}{365} = -20.16$$

$$\delta = -20.16^\circ$$

$$H = 2 \times 15 = 30^\circ$$

$$L = 40^\circ$$

Eq. 20-3

$$\sin \beta = \cos L \cos H \cos \delta + \sin L \sin \delta$$

$$\sin \beta = \cos 40 \cos 30 \cos (-20.16) + \sin 40 \sin (-20.16)$$

$$\beta = 23.66$$

Eq. 20-4

$$\sin \phi = \frac{\cos \delta \sin H}{\cos \beta}$$

$$\sin \phi = \frac{\cos(-20.6) \sin 30}{\cos 23.66}$$

$$\phi = 30.83$$

Eq. 20-8.

$$\cos \theta = \cos \beta \cos \gamma \sin \Sigma + \sin \beta \cos \Sigma$$

$$\Sigma = \text{tilt angle} = -30$$

For facing west, Eq. 20-6.

$$\gamma = \phi \pm \varphi$$

$$\varphi = 60$$

$$\gamma = 30.83 - 60 = -29.17$$

$$\cos \theta = \cos 23.66 \cos(-29.17) \sin(-30) + \sin 23.66 \cos(-30)$$

$$\cos \theta = -0.05238$$

$$\theta = 93 > 90$$

Therefore

$$I_T = 0.00 \text{ W/m}^2$$

Then:

$$\text{June 21, 2 P.M. } I_T = 274.80 \text{ W/m}^2$$

$$\text{June 21, 6 P.M. } I_T = 0.00 \text{ W/m}^2$$

$$\text{January 21, 2 P.M. } I_T = 0.00 \text{ W/m}^2$$

Ans.

Design (b) is most effective on June 21 at 2 P.M. but least effective on June 21 at 6 P.M. Design (a) is most effective on January 21, at 2 P.M.

- 0 0 0 -

- 21-1. A tube 1.5 m long has a speaker at one end and a reflecting plug at the other. The frequency of a pure-tone generator driving the speaker is to be set so that standing waves will develop in the tube. What frequency is required?

Solution: Eq. 21-3.

$$\lambda = c / f$$

$$\lambda = x = 1.5 \text{ m}$$

$$c = 344 \text{ m/s}$$

$$f = c / \lambda = (344 \text{ m/s}) / (1.5 \text{ m})$$

$$f = 229 \text{ Hz}$$

$$\text{At } x = 2\lambda$$

$$\lambda = x / 2 = 1.5 \text{ m} / 2 = 0.75 \text{ m}$$

$$f = (344 \text{ m/s}) / (0.75 \text{ m}) = 458 \text{ Hz}$$

Ans. 229 Hz, 458 Hz, etc.,

- 21-2. The sound power emitted by a certain rocket engine is 10^7 W , which is radiated uniformly in all directions.
 (a) Calculate the amplitude of the sound pressure fluctuation 10 m removed from the source.
 (b) What percentage is this amplitude of the standard atmospheric pressure?

Solution:

(a)

$$E = \frac{A p_o^2}{2c\rho} \text{ Watts}$$

$$A = 4\pi r^2$$

$$E = \frac{4\pi r^2 p_o^2}{2c\rho}$$

$$r = 10 \text{ m}$$

$$c = 344 \text{ m/s}$$

$$\rho = 1.18 \text{ kg/m}^3$$

$$E = 10^7 \text{ W}$$

$$E = \frac{4\pi(10)^2 p_o^2}{2(344)(1.18)} = 10^7$$

$$p_o = 2,542 \text{ Pa} \text{ --- Ans.}$$

(b)

$$\text{Percentage} = \frac{2,542 \text{ Pa}}{101,325 \text{ Pa}} = 0.0251$$

$$\text{Percentage} = 2.51 \% \text{ --- Ans.}$$

- 21-3. At a distance of 3 m from a sound source of 100 W that radiates uniformly in all directions what is the SPL due to direct radiation from this source?

Solution:

Combine Eq. 21-8 and Eq. 21-9.

$$\frac{p_{rms}^2}{\rho c} = \frac{E}{4\pi r^2}$$

$$p_{rms}^2 = \frac{E\rho c}{4\pi r^2}$$

$$E = 100 \text{ W}$$

$$c = 344 \text{ m/s}$$

$$\rho = 1.18 \text{ kg/m}^3$$

$$r = 3 \text{ m}$$

$$p_{rms}^2 = \frac{(100)(1.18)(344)}{4\pi(3)^2}$$

$$p_{rms}^2 = 359 \text{ Pa}^2$$

$$p_{ref} = 20 \text{ } \mu\text{Pa} = 20 \times 10^{-6} \text{ Pa}$$

Eq. 21-11.

$$\text{SPL} = 10 \log \frac{p_{rms}^2}{p_{ref}^2} = 10 \log \left[\frac{359}{(20 \times 10^{-6})^2} \right]$$

SPL = 119.5 dB --- Ans.

- 21-4. An octave-band measurement resulted in the following SPL measurements in decibels for the eight octave bands listed in Table 21-1: 65.4, 67.3, 71.0, 74.2, 72.6, 70.9, 67.8, and 56.0, respectively. What is the expected overall SPL reading?

Solution:

$$\text{SPL} = 10 \log \frac{\sum I}{10^{-12}}$$

Eq. 21-14.

$$10 \log \frac{I_1}{10^{-12}} = IL_1 = \text{SPL}_1$$

$$I = 10^{-12} \left(10^{\text{SPL}/10} \right)$$

$$\sum I = 10^{-12} \left(10^{65.4/10} + 10^{67.3/10} + 10^{71/10} + 10^{74.2/10} + 10^{72.6/10} + 10^{70.9/10} + 10^{67.8/10} + 10^{56/10} \right)$$

$$\frac{\sum I}{10^{-12}} = 84,653,020$$

$$\text{SPL} = 10 \log \frac{\sum I}{10^{-12}}$$

$$\text{SPL} = 10 \log(84,653,020)$$

SPL = 79.3 dB --- Ans.

- 21-5. A room has a ceiling area of 25 m² with acoustic material that has an absorption coefficient of 0.55; the walls and floor have a total area of 95 m² with an absorption coefficient of 0.12. A sound source located in the center of the room emits a sound power level of 70 dB. What is the SPL at a location 3 m from the source?

Solution:

$$\alpha = \frac{I_{abs}}{I_{inc}}$$

Eq. 21-17.

$$\bar{\alpha} = \frac{S_1\alpha_1 + S_2\alpha_2}{S_1 + S_2}$$

$$S_1 = 25 \text{ m}^2, \alpha_1 = 0.55$$

$$S_2 = 95 \text{ m}^2, \alpha_2 = 0.12$$

$$\bar{\alpha} = \frac{(25)(0.55) + (95)(0.12)}{25 + 95}$$

$$\bar{\alpha} = 0.2096$$

$$\text{SPL} = 70 \text{ dB}$$

Eq. 21-18.

$$R = \frac{S\bar{\alpha}}{1 - \bar{\alpha}}$$

$$S = 25 \text{ m}^2 + 95 \text{ m}^2 = 120 \text{ m}^2$$

$$R = \frac{(120)(0.2096)}{1 - 0.2096} = 31.82 \text{ m}^2$$

Fig. 21-9, at Distance = 3 m

$$\text{SPL} - \text{PWL} = -8$$

$$\text{SPL} = \text{PWL} - 8$$

$$\text{SPL} = 70 - 8$$

$$\text{SPL} = 62 \text{ dB} \text{ --- Ans.}$$

- 21-6. In computing the transmission of sound power through a duct, the standard calculation procedure for a branch take-off is to assume that the sound power in watts divides in ratio of the areas of the two branches. If a PWL of 78 dB exists before the branch, what is the distribution of power in the two branches if the areas of the branches (a) are equal and (b) are in a ration of 4:1?

Solution: PWL = 78 dB

Eq. 21-10.

$$\text{PWL} = 10\log \frac{E}{E_0}$$

$$\frac{E}{E_0} = 10^{(\text{PWL}/10)} = 10^{(78/10)} = 63,095,735$$

(a) For equal area:

$$\frac{E_1}{E_0} = \frac{1}{2} (63,095,735) = 31,547,868$$

$$\text{PWL}_1 = 10\log(31,547,868)$$

$$\text{PWL}_1 = 75 \text{ dB} \text{ --- Ans.}$$

(b) For ratio of 4:1:

$$\frac{E_2}{E_0} = \frac{1}{5} (63,095,735) = 12,619,145$$

$$PWL_2 = 10\log(12,619,145)$$

$$PWL_2 = 71 \text{ dB} \text{ --- Ans.}$$

$$\frac{E_3}{E_0} = \frac{4}{5} (63,095,735) = 50,476,588$$

$$PWL_3 = 10\log(50,476,588)$$

$$PWL_3 = 77 \text{ dB} \text{ --- Ans.}$$

- 0 0 0 -