

UPLOADED BY Ahmad Jundi

# **SOLUTIONS MANUAL**

# **DIGITAL DESIGN**

**FOURTH EDITION**

**M. MORRIS MANO**

**California State University, Los Angeles**

**MICHAEL D. CILETTI**

**University of Colorado, Colorado Springs**

rev 01/21/2007

## CHAPTER 1

**1.1** Base-10: 16 17 18 19 20 21 22 23 24 25 26 27 28 29 30 31 32  
Octal: 20 21 22 23 24 25 26 27 30 31 32 33 34 35 36 37 40  
Hex: 10 11 12 13 14 15 16 17 18 19 1A 1B 1C 1D 1E 1F 20  
Base-13 A B C 10 11 12 13 14 15 16 17 18 19 23 24 25 26

**1.2** (a) 32,768 (b) 67,108,864 (c) 6,871,947,674

**1.3**  $(4310)_5 = 4 * 5^3 + 3 * 5^2 + 1 * 5^1 = 580_{10}$

$$(198)_{12} = 1 * 12^2 + 9 * 12^1 + 8 * 12^0 = 260_{10}$$

$$(735)_8 = 7 * 8^2 + 3 * 8^1 + 5 * 8^0 = 477_{10}$$

$$(525)_6 = 5 * 6^2 + 2 * 6^1 + 5 * 6^0 = 197_{10}$$

**1.4** 14-bit binary: 11\_1111\_1111\_1111  
Decimal:  $2^{14} - 1 = 16,383_{10}$   
Hexadecimal: 3FFF<sub>16</sub>

**1.5** Let b = base

(a)  $14/2 = (b + 4)/2 = 5$ , so b = 6

(b)  $54/4 = (5*b + 4)/4 = b + 3$ , so  $5 * b = 52 - 4$ , and b = 8

(c)  $(2 * b + 4) + (b + 7) = 4b$ , so b = 11

**1.6**  $(x - 3)(x - 6) = x^2 - (6 + 3)x + 6*3 = x^2 - 11x + 22$

Therefore:  $6 + 3 = b + 1m$  so b = 8

Also,  $6*3 = (18)_{10} = (22)_8$

**1.7** 68BE = 0110\_1000\_1011\_1110 = 110\_100\_010\_111\_110 = (64276)<sub>8</sub>

**1.8** (a) Results of repeated division by 2 (quotients are followed by remainders):

$431_{10} = 215(1); 107(1); 53(1); 26(1); 13(0); 6(1) 3(0) 1(1)$   
Answer: 1111\_1010<sub>2</sub> = FA<sub>16</sub>

(b) Results of repeated division by 16:

$431_{10} = 26(15); 1(10)$  (Faster)  
Answer: FA = 1111\_1010

**1.9** (a)  $10110.0101_2 = 16 + 4 + 2 + .25 + .0625 = 22.3125$

(b)  $16.5_{16} = 16 + 6 + 5*(.0615) = 22.3125$

(c)  $26.24_8 = 2 * 8 + 6 + 2/8 + 4/64 = 22.3125$

(d)  $FAFA.B_{16} = 15 \cdot 16^3 + 10 \cdot 16^2 + 15 \cdot 16 + 10 + 11/16 = 64,250.6875$

(e)  $1010.1010_2 = 8 + 2 + .5 + .125 = 10.625$

1.10 (a)  $1.10010_2 = 0001.1001_2 = 1.9_{16} = 1 + 9/16 = 1.563_{10}$

(b)  $110.010_2 = 0110.0100_2 = 6.4_{16} = 6 + 4/16 = 6.25_{10}$

Reason:  $110.010_2$  is the same as  $1.10010_2$  shifted to the left by two places.

1.11

$$\begin{array}{r}
 \underline{1011.11} \\
 101 \overline{) 111011.0000} \\
 \underline{101} \phantom{0000} \\
 01001 \phantom{000} \\
 \underline{101} \phantom{000} \\
 1001 \phantom{000} \\
 \underline{101} \phantom{000} \\
 1000 \phantom{000} \\
 \underline{101} \phantom{000} \\
 0110
 \end{array}$$

The quotient is carried to two decimal places, giving  $1011.11$

Checking:  $111011_2 / 101_2 = 59_{10} / 5_{10} \cong 1011.11_2 = 58.75_{10}$

1.12 (a)  $10000$  and  $110111$

$$\begin{array}{r}
 1011 \\
 +101 \\
 \hline
 10000 = 16_{10}
 \end{array}$$

$$\begin{array}{r}
 1011 \\
 \times 101 \\
 \hline
 1011 \\
 1011 \\
 \hline
 110111 = 55_{10}
 \end{array}$$

(b)  $62_h$  and  $958_h$

$$\begin{array}{r}
 2E_h \quad 0010\_1110 \\
 +34_h \quad 0011\_0100 \\
 \hline
 62_h \quad 0110\_0010 = 98_{10}
 \end{array}$$

$$\begin{array}{r}
 2E_h \\
 \times 34_h \\
 \hline
 B^38 \\
 \hline
 8^2A \\
 \hline
 9 \ 5 \ 8_h = 2392_{10}
 \end{array}$$

1.13 (a) Convert  $27.315$  to binary:

	Integer Quotient		Remainder	Coefficient
$27/2 =$	13	+	$\frac{1}{2}$	$a_0 = 1$
$13/2$	6	+	$\frac{1}{2}$	$a_1 = 1$
$6/2$	3	+	0	$a_2 = 0$
$3/2$	1	+	$\frac{1}{2}$	$a_3 = 1$
$\frac{1}{2}$	0	+	$\frac{1}{2}$	$a_4 = 1$

$$27_{10} = 11011_2$$

	Integer	Fraction	Coefficient
.315 x 2 =	0	+ .630	a <sub>1</sub> = 0
.630 x 2 =	1	+ .26	a <sub>2</sub> = 1
.26 x 2 =	0	+ .52	a <sub>3</sub> = 0
.52 x 2 =	1	+ .04	a <sub>4</sub> = 1

$$.315_{10} \cong .0101_2 = .25 + .0625 = .3125$$

$$27.315 \cong 11011.0101_2$$

**(b)**  $2/3 \cong .666666667$

	Integer	Fraction	Coefficient
.6666_6666_67 x 2 =	1	+ .3333_3333_34	a <sub>1</sub> = 1
.3333333334 x 2 =	0	+ .6666666668	a <sub>2</sub> = 0
.6666666668 x 2 =	1	+ .3333333336	a <sub>3</sub> = 1
.3333333336 x 2 =	0	+ .6666666672	a <sub>4</sub> = 0
.6666666672 x 2 =	1	+ .3333333344	a <sub>5</sub> = 1
.3333333344 x 2 =	0	+ .6666666688	a <sub>6</sub> = 0
.6666666688 x 2 =	1	+ .3333333376	a <sub>7</sub> = 1
.3333333376 x 2 =	0	+ .6666666752	a <sub>8</sub> = 0

$$.666666667_{10} \cong .10101010_2 = .5 + .125 + .0313 + ..0078 = .6641_{10}$$

$$.10101010_2 = .1010_2 = .AA_{16} = 10/16 + 10/256 = .6641_{10} \text{ (Same as (b)).}$$

**1.14**    **(a)**            1000\_0000            **(b)**            0000\_0000            **(c)**            1101\_1010  
                   1s comp: 0111\_1111            1s comp: 1111\_1111            1s comp: 0010\_0101  
                   2s comp: 1000\_0000            2s comp: 0000\_0000            2s comp: 0010\_0110

**(d)**            0111\_0110            **(e)**            1000\_0101            **(f)**            1111\_1111  
                   1s comp: 1000\_1001            1s comp: 0111\_1010            1s comp: 0000\_0000  
                   2s comp: 1000\_1010            2s comp: 0111\_1011            2s comp: 0000\_0001

**1.15**    **(a)**            52,784,630            **(b)**            63,325,600  
                   9s comp: 47,215,369            9s comp: 36,674,399  
                   10s comp: 47,215,370            10s comp: 36,674,400

**(c)**            25,000,000            **(d)**            00,000,000  
                   9s comp: 74,999,999            9s comp: 99,999,999  
                   10s comp: 75,000,000            10s comp: 00,000,000

**1.16**                    B2FA            B2FA: 1011\_0010\_1111\_1010  
                   15s comp: 4D05            1s comp: 0100\_1101\_0000\_0101  
                   16s comp: 4D06            2s comp: 0100\_1101\_0000\_0110 = 4D06

**1.17**    **(a)** 3409 → 03409 → 96590 (9s comp) → 96591 (10s comp)  
                   06428 – 03409 = 06428 + 96591 = 03019

**(b)** 1800 → 01800 → 98199 (9s comp) → 98200 (10 comp)  
                   125 – 1800 = 00125 + 98200 = 98325 (negative)  
                   Magnitude: 1675  
                   Result: 125 – 1800 = 1675

(c)  $6152 \rightarrow 06152 \rightarrow 93847$  (9s comp)  $\rightarrow 93848$  (10s comp)  
 $2043 - 6152 = 02043 + 93848 = 95891$  (Negative)  
 Magnitude: 4109  
 Result:  $2043 - 6152 = -4109$

(d)  $745 \rightarrow 00745 \rightarrow 99254$  (9s comp)  $\rightarrow 99255$  (10s comp)  
 $1631 - 745 = 01631 + 99255 = 0886$  (Positive)  
 Result:  $1631 - 745 = 886$

**1.18** Note: Consider sign extension with 2s complement arithmetic.

<p>(a)</p> $\begin{array}{r} 10001 \\ 1s \text{ comp: } 01110 \\ 2s \text{ comp: } 01111 \\ \hline 10011 \\ \text{Diff: } 00010 \end{array}$	<p>(b)</p> $\begin{array}{r} 100011 \\ 1s \text{ comp: } 1011100 \text{ with sign extension} \\ 2s \text{ comp: } 1011101 \\ \hline 0100010 \\ 1111111 \text{ sign bit indicates that the result is negative} \\ 0000001 \text{ 2s complement} \\ -000001 \text{ result} \end{array}$
--	---

<p>(c)</p> $\begin{array}{r} 101000 \\ 1s \text{ comp: } 1010111 \\ 2s \text{ comp: } 1011000 \\ \hline 001001 \\ \text{Diff: } 1100001 \text{ (negative)} \\ 0011111 \text{ (2s comp)} \\ -011111 \text{ (diff is -31)} \end{array}$	<p>(d)</p> $\begin{array}{r} 10101 \\ 1s \text{ comp: } 1101010 \text{ with sign extension} \\ 2s \text{ comp: } 1101011 \\ \hline 110000 \\ 0011011 \text{ sign bit indicates that the result is positive} \\ \text{Check: } 48 - 21 = 27 \end{array}$
---	---

**1.19**  $+9286 \rightarrow 009286$ ;  $+801 \rightarrow 000801$ ;  $-9286 \rightarrow 990714$ ;  $-801 \rightarrow 999199$

(a)  $(+9286) + (+801) = 009286 + 000801 = 010087$

(b)  $(+9286) + (-801) = 009286 + 999199 = 008485$

(c)  $(-9286) + (+801) = 990714 + 000801 = 991515$

(d)  $(-9286) + (-801) = 990714 + 999199 = 989913$

**1.20**  $+49 \rightarrow 0\_110001$  (Needs leading zero indicate + value);  $+29 \rightarrow 0\_011101$  (Leading 0 indicates + value)  
 $-49 \rightarrow 1\_001111$ ;  $-29 \rightarrow 1\_100011$

(a)  $(+29) + (-49) = 0\_011101 + 1\_001111 = 1\_101100$  (1 indicates negative value.)  
 Magnitude =  $0\_010100$ ; Result  $(+29) + (-49) = -20$

(b)  $(-29) + (+49) = 1\_100011 + 0\_110001 = 0\_010100$  (0 indicates positive value)  
 $(-29) + (+49) = +20$

(c) Must increase word size by 1 (sign extension) to accommodate overflow of values:  
 $(-29) + (-49) = 11\_100011 + 11\_001111 = 10\_110010$  (1 indicates negative result)  
 Magnitude:  $1\_001110 = 78_{10}$   
 Result:  $(-29) + (-49) = -78$

**1.21** +9742 → 009742 → 990257 (9's comp) → 990258 (10s) comp  
 +641 → 000641 → 999358 (9's comp) → 999359 (10s) comp

(a) (+9742) + (+641) → 010383

(b) (+9742) + (-641) → 009742 + 999359 = 009102

Result: (+9742) + (-641) = 9102

(c) -9742) + (+641) = 990258 + 000641 = 990899 (negative)

Magnitude: 009101

Result: (-9742) + (641) = -9101

(d) (-9742) + (-641) = 990258 + 999359 = 989617 (Negative)

Magnitude: 10383

Result: (-9742) + (-641) = -10383

**1.22** 8,723

BCD: 1000\_0111\_0010\_0011

ASCII: 0\_011\_1000\_011\_0111\_011\_0010\_011\_0001

**1.23**

1000	0100	0010	( 842)
0101	0011	0111	(+537)
1101	0111	1001	
0110			
0001	0011	0111	0101 (1,379)

**1.24** (a)

6	3	1	1	Decimal
0	0	0	0	0
0	0	0	1	1
0	0	1	0	2
0	1	0	0	3
0	1	1	0	4 (or 0101)
0	1	1	1	5
1	0	0	0	6
1	0	1	0	7 (or 1001)
1	0	1	1	8
1	1	0	0	9

(b)

6	4	2	1	Decimal
0	0	0	0	0
0	0	0	1	1
0	0	1	0	2
0	0	1	1	3
0	1	0	0	4
0	1	0	1	5
1	0	0	0	6 (or 0110)
1	0	0	1	7
1	0	1	0	8
1	0	1	1	9

**1.25** (a) 5,137<sub>10</sub> BCD: 0101\_0011\_0111

(b) Excess-3: 1000\_0100\_0110\_1010

(c) 2421: 1011\_0001\_0011\_0111

(d) 6311: 0111\_0001\_0100\_1001

**1.26** 5,137 9s Comp: 4,862

2421 code: 0100\_1110\_1100\_1000

1s comp: 1011\_0001\_0011\_0111 same as (c) in 1.25

**1.27** For a deck with 52 cards, we need 6 bits ( $32 < 52 < 64$ ). Let the msb's select the suit (e.g., diamonds, hearts, clubs, spades are encoded respectively as 00, 01, 10, and 11. The remaining four bits select the "number" of the card. Example: 0001 (ace) through 1011 (9), plus 101 through 1100 (jack, queen, king). This a jack of spades might be coded as 11\_1010. (Note: only 52 out of 64 patterns are used.)

**1.28** G (dot) (space) B o o l e  
 01000111\_11101111\_01101000\_01101110\_00100000\_11000100\_11101111\_11100101

**1.29** Bill Gates

**1.30** 73 F4 E5 76 E5 4A EF 62 73

73: 0\_111\_0011 s  
 F4: 1\_111\_0100 t  
 E5: 1\_110\_0101 e  
 76: 0\_111\_0110 v  
 E5: 1\_110\_0101 e  
 4A: 0\_100\_1010 j  
 EF: 1\_110\_1111 o  
 62: 0\_110\_0010 b  
 73: 0\_111\_0011 s

**1.31**  $62 + 32 = 94$  printing characters

**1.32** bit 6 from the right

**1.33** (a) 897 (b) 564 (c) 871 (d) 2,199

**1.34** ASCII for decimal digits with odd parity:

(0): 10110000 (1): 00110001 (2): 00110010 (3): 10110011  
 (4): 00110100 (5): 10110101 (6): 10110110 (7): 00110111  
 (8): 00111000 (9): 10111001

**1.35** (a)

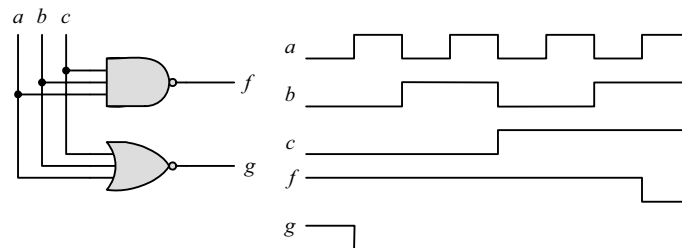

**1.36**

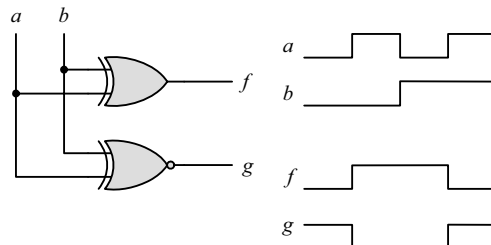

## CHAPTER 2

### 2.1 (a)

$x y z$	$x + y + z$	$(x + y + z)'$	$x'$	$y'$	$z'$	$x' y' z'$	$x y z$	$(xyz)$	$(xyz)'$	$x'$	$y'$	$z'$	$x' + y' + z'$
000	0	1	1	1	1	1	000	0	1	1	1	1	1
001	1	0	1	1	0	0	001	0	1	1	1	0	1
010	1	0	1	0	1	0	010	0	1	1	0	1	1
011	1	0	1	0	0	0	011	0	1	1	0	0	1
100	1	0	0	1	1	0	100	0	1	0	1	1	1
101	1	0	0	1	0	0	101	0	1	0	1	0	1
110	1	0	0	0	1	0	110	0	1	0	0	1	1
111	1	0	0	0	0	0	111	1	0	0	0	0	0

### (b)

$x y z$	$x + yz$	$(x + y)$	$(x + z)$	$(x + y)(x + z)$
000	0	0	0	0
001	0	0	1	0
010	0	1	0	0
011	1	1	1	1
100	1	1	1	1
101	1	1	1	1
110	1	1	1	1
111	1	1	1	1

### (c)

$x y z$	$x(y + z)$	$xy$	$xz$	$xy + xz$
000	0	0	0	0
001	0	0	0	0
010	0	0	0	0
011	0	0	0	0
100	0	0	0	0
101	1	0	1	1
110	1	1	0	1
111	1	1	1	1

### (c)

$x y z$	$x$	$y + z$	$x + (y + z)$	$(x + y)$	$(x + y) + z$
000	0	0	0	0	0
001	0	1	1	0	1
010	0	1	1	1	1
011	0	1	1	1	1
100	1	0	1	1	1
101	1	1	1	1	1
110	1	1	1	1	1
111	1	1	1	1	1

### (d)

$x y z$	$yz$	$x(yz)$	$xy$	$(xy)z$
000	0	0	0	0
001	0	0	0	0
010	0	0	0	0
011	1	0	0	0
100	0	0	0	0
101	0	0	0	0
110	0	0	1	0
111	1	1	1	1

2.2 (a)  $xy + xy' = x(y + y') = x$

(b)  $(x + y)(x + y') = x + yy' = x(x + y') + y(x + y') = xx + xy' + xy + yy' = x$

(c)  $xyz + x'y + xyz' = xy(z + z') + x'y = xy + x'y = y$

(d)  $(A + B)'(A' + B') = (A'B')(A B) = (A'B')(BA) = A'(B'BA) = 0$

(e)  $xyz' + x'yz + xyz + x'yz' = xy(z + z') + x'y(z + z') = xy + x'y = y$

(f)  $(x + y + z)(x' + y' + z) = xx' + xy' + xz + x'y + yy' + yz + x'z' + y'z' + zz' = xy' + xz + x'y + yz + x'z' + y'z' = x \oplus y + (x \oplus z)' + (y \oplus z)'$

2.3 (a)  $ABC + A'B + ABC' = AB + A'B = B$



(b)  $x'yz + xz = (x'y + x)z = z(x + x')(x + y) = z(x + y)$

(c)  $(x + y)'(x' + y') = x'y'(x' + y') = x'y'$

(d)  $xy + x(wz + wz') = x(y + wz + wz') = x(w + y)$

(e)  $(BC' + A'D)(AB' + CD') = BC'AB' + BC'CD' + A'DAB' + A'DCD' = 0$

(f)  $(x + y' + z')(x' + z') = xx' + xz' + x'y' + y'z' + x'z' + z'z' = z' + y'(x' + z') = z' + x'y'$

2.4 (a)  $A'C' + ABC + AC' = C' + ABC = (C + C')(C' + AB) = AB + C'$

(b)  $(x'y' + z)' + z + xy + wz = (x'y')'z' + z + xy + wz = [(x + y)z' + z] + xy + wz = (z + z')(z + x + y) + xy + wz = z + wz + x + xy + y = z(1 + w) + x(1 + y) + y = x + y + z$

(c)  $A'B(D' + C'D) + B(A + A'CD) = B(A'D' + A'C'D + A + A'CD) = B(A'D' + A + A'D(C + C')) = B(A + A'(D' + D)) = B(A + A') = B$

(d)  $(A' + C)(A' + C')(A + B + C'D) = (A' + CC')(A + B + C'D) = A'(A + B + C'D) = AA' + A'B + A'C'D = A'(B + C'D)$

(e)  $ABCD + A'BD + ABC'D = ABD + A'BD = BD$

2.5 (a)

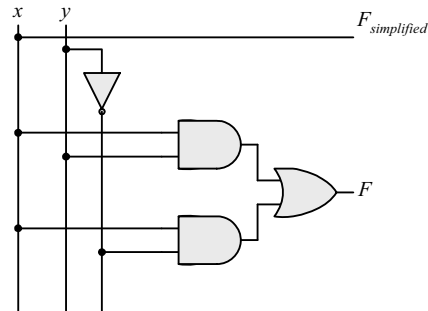

(b)

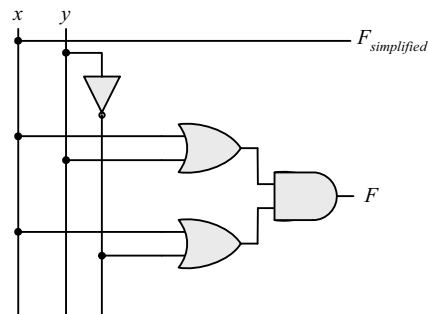

(c)

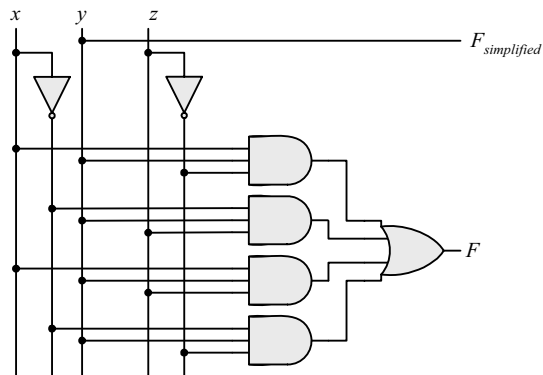

(d)

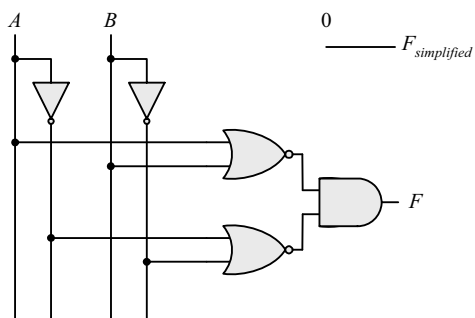

(e)

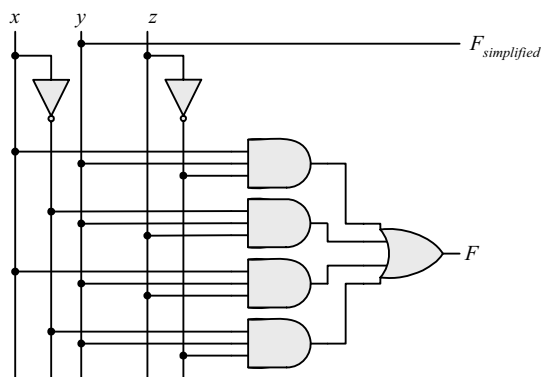

(f)

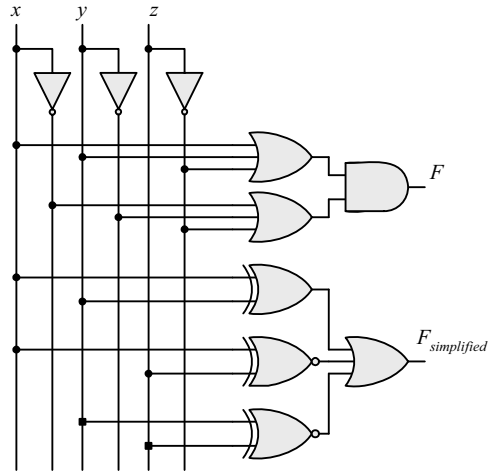

2.6 (a)

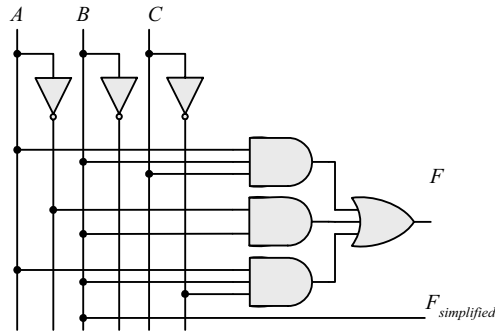

(b)

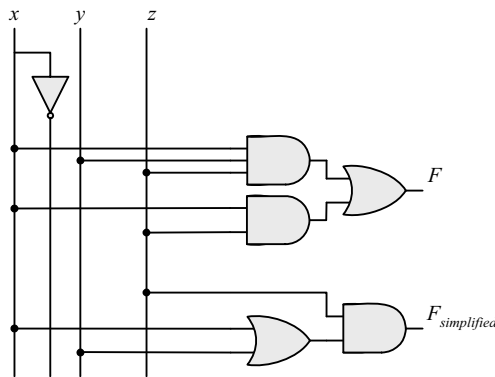

(c)

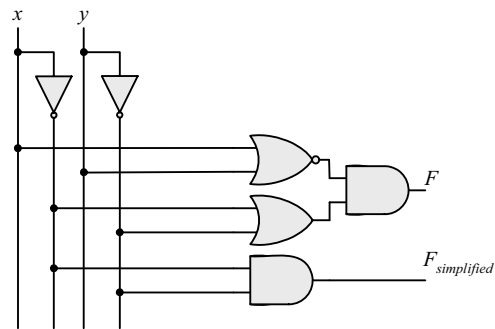

(d)

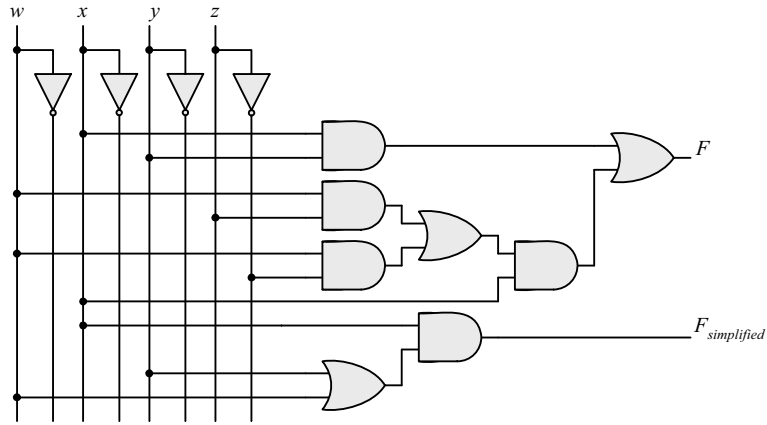

(e)

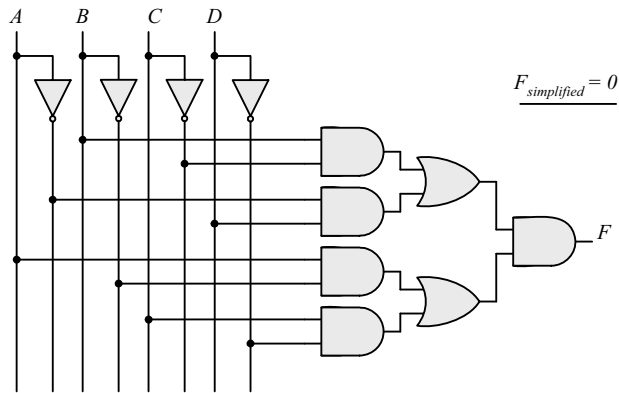

(f)

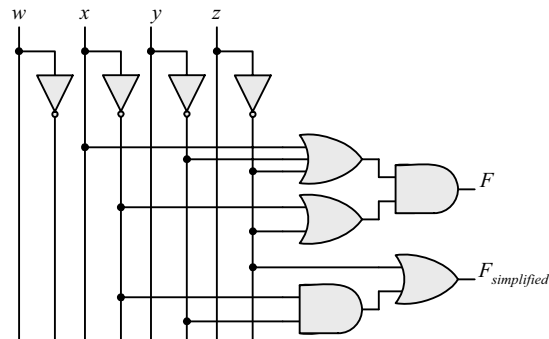

2.7

(a)

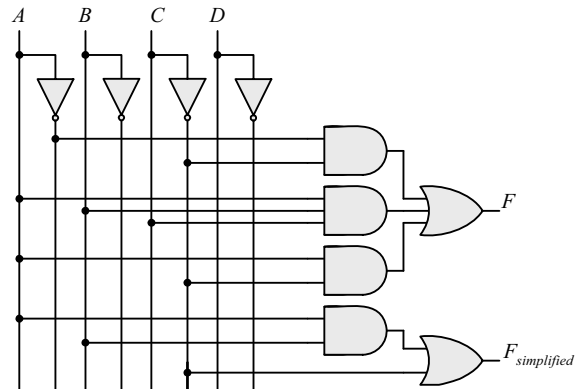

(b)

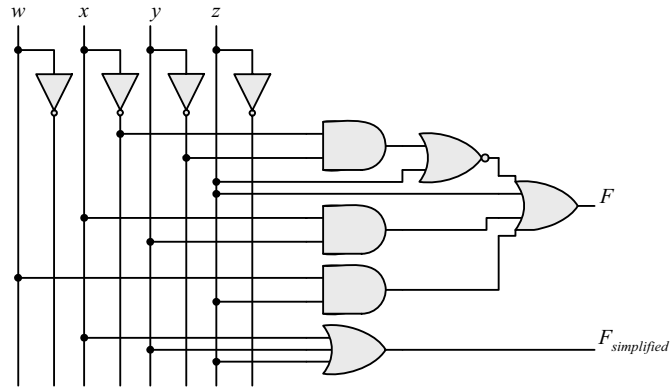

(c)

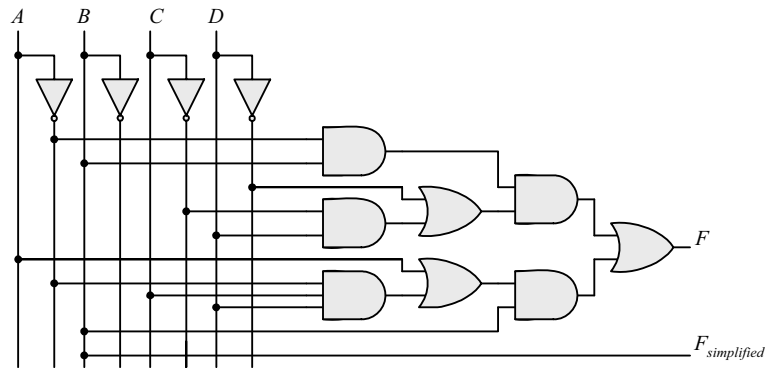

(d)

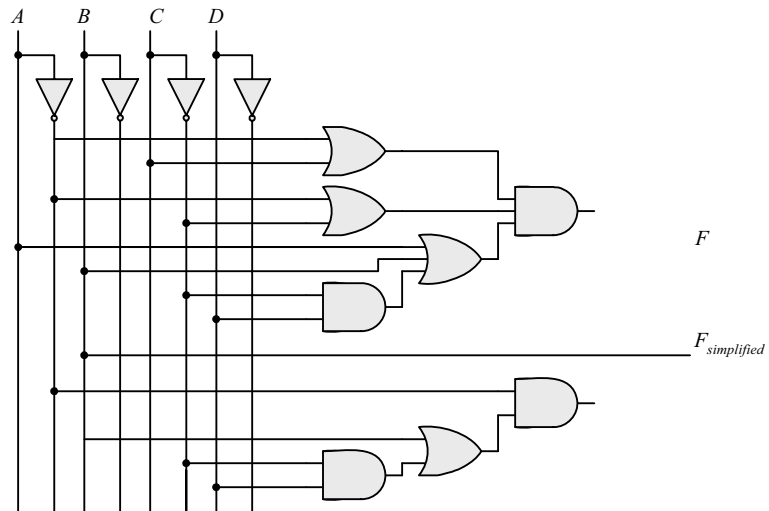

(e)

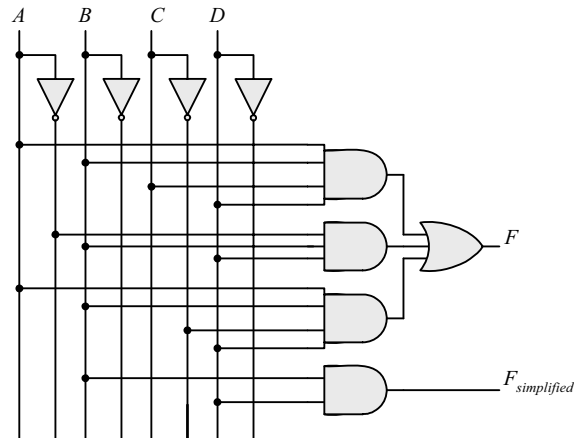

2.8  $F' = (wx + yz)' = (wx)'(yz)' = (w' + x')(y' + z')$

$FF' = wx(w' + x')(y' + z') + yz(w' + x')(y' + z') = 0$   
 $F + F' = wx + yz + (wx + yz)' = A + A' = 1$  with  $A = wx + yz$

2.9 (a)  $F' = (xy' + x'y)' = (xy')'(x'y)' = (x' + y)(x + y') = xy + x'y'$

(b)  $F' = [(A'B + CD)E' + E]' = [(A'B + CD) + E]' = (A'B + CD)'E' = (A'B)'(CD)'E'$   
 $F' = (A + B')(C' + D')E' = AC'E' + A'D'E' + B'C'E' + B'D'E'$

(c)  $F' = [(x' + y + z')(x + y')(x + z)]' = (x' + y + z)' + (x + y')' + (x + z)' =$   
 $F' = xy'z + x'y + x'z'$

2.10 (a)  $F_1 + F_2 = \Sigma m_{1i} + \Sigma m_{2i} = \Sigma (m_{1i} + m_{2i})$

(b)  $F_1 F_2 = \Sigma m_i \Sigma m_j$  where  $m_i m_j = 0$  if  $i \neq j$  and  $m_i m_j = 1$  if  $i = j$

2.11 (a)  $F(x, y, z) = \Sigma(1, 4, 5, 6, 7)$

(b)  $F(x, y, z) = \Sigma(0, 2, 3, 7)$

$F = xy + xy' + y'z$	
x y z	F
0 0 0	0
0 0 1	1
0 1 0	0
0 1 1	0
1 0 0	1
1 0 1	1
1 1 0	1
1 1 1	1

$F = x'z' + yz$	
x y z	F
0 0 0	1
0 0 1	0
0 1 0	1
0 1 1	1
1 0 0	0
1 0 1	0
1 1 0	0
1 1 1	1

2.12  $A = 1011\_0001$   
 $B = 1010\_1100$

- (a)  $A \text{ AND } B = 1010\_0000$
- (b)  $A \text{ OR } B = 1011\_1101$
- (c)  $A \text{ XOR } B = 0001\_1101$

(d)  $NOT A = 0100\_1110$

(e)  $NOT B = 0101\_0011$

2.13

(a)

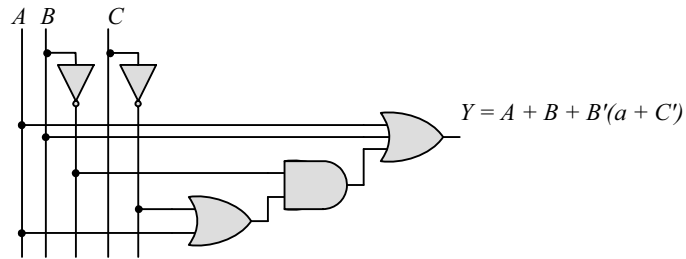

(b)

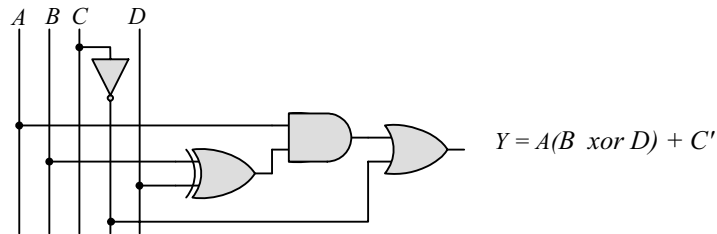

(c)

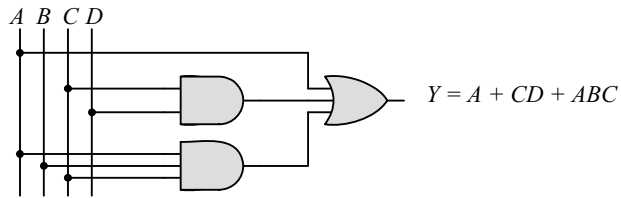

(d)

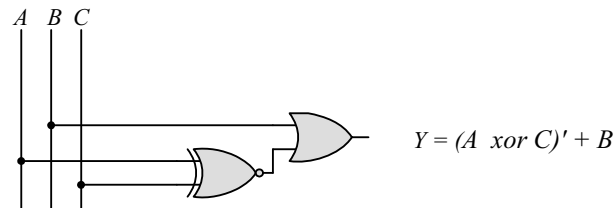

(e)

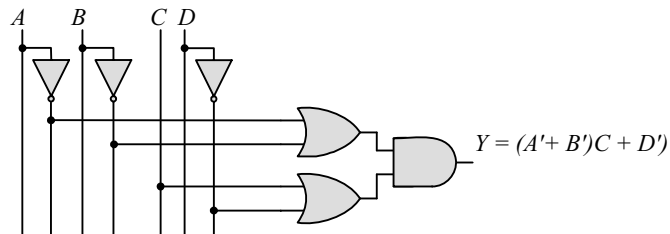

(f)

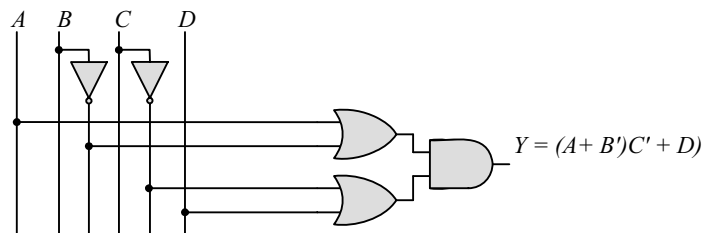

2.14 (a)

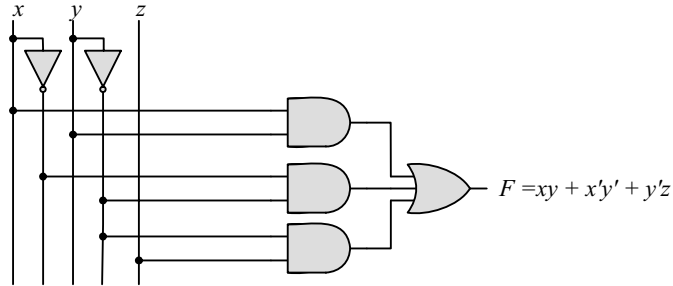

(b)

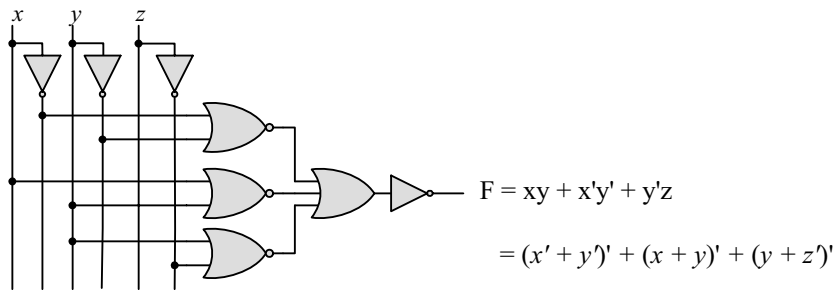

(c)

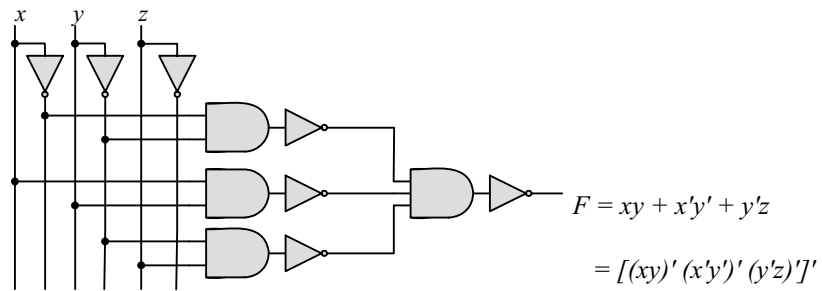

(d)

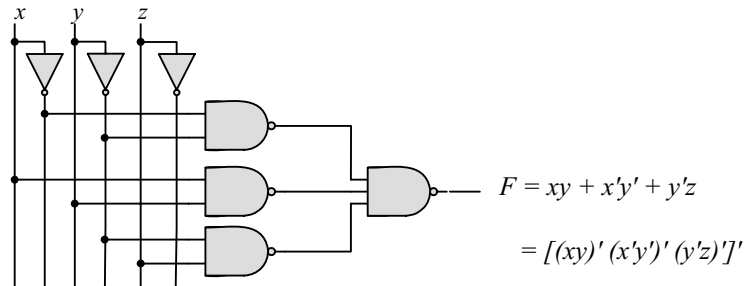



(e)

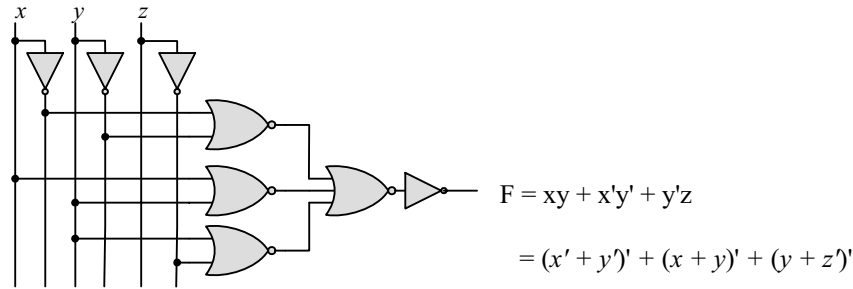

2.15 (a)  $T_1 = A'B'C' + A'B'C + A'BC' = A'B'(C' + C) + A'C'(B' + B) = A'B' + A'C' = A'(B' + C')$

(b)  $T_2 = T_1' = A'BC + AB'C' + AB'C + ABC' + ABC$   
 $= BC(A' + A) + AB'(C' + C) + AB(C' + C)$   
 $= BC + AB' + AB = BC + A(B' + B) = A + BC$

$\Sigma(3, 5, 6, 7) = \Pi(0, 1, 2, 4)$

$T_1 = A'B'C' + A'B'C + A'BC'$   
 $\swarrow \quad \searrow$   
 $A'B' \quad A'C'$

$T_1 = A'B' A'C' = A'(B' + C')$

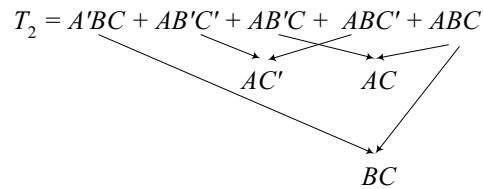

$T_2 = AC' + BC + AC = A + BC$

2.16 (a)  $F(A, B, C) = A'B'C' + A'B'C + A'BC' + A'BC + AB'C' + AB'C + ABC' + ABC$   
 $= A'(B'C' + B'C + BC' + BC) + A((B'C' + B'C + BC' + BC))$   
 $= (A' + A)(B'C' + B'C + BC' + BC) = B'C' + B'C + BC' + BC$   
 $= B'(C' + C) + B(C' + C) = B' + B = 1$

(b)  $F(x_1, x_2, x_3, \dots, x_n) = \Sigma m_i$  has  $2^{n-1}/2$  minterms with  $x_1$  and  $2^{n-1}/2$  minterms with  $x'_1$ , which can be factored and removed as in (a). The remaining  $2^{n-1}$  product terms will have  $2^{n-1}/2$  minterms with  $x_2$  and  $2^{n-1}/2$  minterms with  $x'_2$ , which and be factored to remove  $x_2$  and  $x'_2$ . continue this process until the last term is left and  $x_n + x'_n = 1$ . Alternatively, by induction,  $F$  can be written as  $F = x_n G + x'_n G$  with  $G = 1$ . So  $F = (x_n + x'_n)G = 1$ .

2.17 (a)  $(xy + z)(y + xz) = xy + yz + xyz + xz = \Sigma(3, 5, 6, 7) = \Pi(0, 1, 2, 4)$

(b)  $(A' + B)(B' + C) = A'B' + A'C + BC = \Sigma(0, 1, 3, 7) = \Pi(2, 4, 5, 6)$

(c)  $y'z + wxy' + wxz' + w'x'z = \Sigma(1, 3, 5, 9, 12, 13, 14) = \Pi(0, 2, 4, 6, 7, 8, 10, 11, 15)$

(d)  $(xy + yz' + x'z)(x + z) = xy + xyz' + xyz + x'z$   
 $= \Sigma(1, 3, 9, 11, 14, 15) = \Pi(0, 2, 4, 5, 6, 7, 8, 10, 12, 13)$

2.18 (a)

wx y z	F	$F = xy'z + x'y'z + w'xy + wx'y + wxy$ $F = \Sigma(1, 5, 6, 7, 9, 10, 11, 13, 14, 15)$
00 0 0	0	
00 0 1	1	
00 1 0	0	
00 1 1	0	
01 0 0	0	
01 0 1	1	
01 1 0	1	
01 1 1	1	
10 0 0	0	
10 0 1	1	
10 1 0	1	
10 1 1	1	
11 0 0	0	
11 0 1	1	
11 1 0	1	
11 1 1	1	

(b)

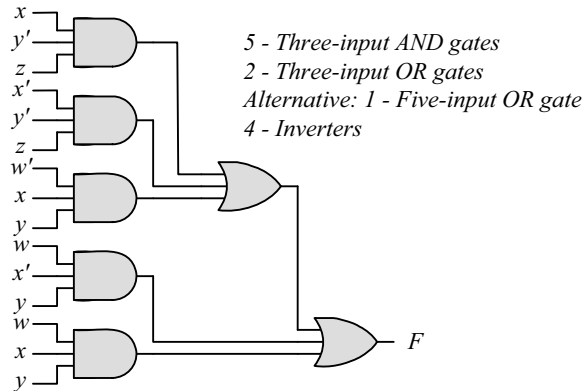

(c)  $F = xy'z + x'y'z + w'xy + wx'y + wxy = y'z + xy + wy = y'z + y(w + x)$

(d)  $F = y'z + yw + yx = \Sigma(1, 5, 9, 13, 10, 11, 13, 15, 6, 7, 14, 15)$   
 $= \Sigma(1, 5, 6, 7, 9, 10, 11, 13, 14, 15)$

(e)

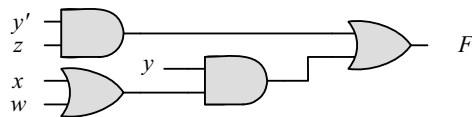

1 - Inverter, 2 - Two-input AND gates, 2 - Two-input OR gates

**2.19**  $F = B'D + A'D + BD$

<i>ABCD</i>	<i>ABCD</i>	<i>ABCD</i>
$\overline{B'D}$	$A'\overline{D}$	$\overline{B'D}$
0001 = 1	0001 = 1	0101 = 5
0011 = 3	0011 = 3	0111 = 7
1001 = 9	0101 = 5	1101 = 13
1011 = 11	0111 = 7	1111 = 15

$F = \Sigma(1, 3, 5, 7, 9, 11, 13, 15) = \Pi(0, 2, 4, 6, 8, 10, 12, 14)$

**2.20** (a)  $F(A, B, C, D) = \Sigma(3, 5, 9, 11, 15)$   
 $F'(A, B, C, D) = \Sigma(0, 1, 2, 4, 6, 7, 8, 10, 12, 13, 14)$

(b)  $F(x, y, z) = \Pi(2, 4, 5, 7)$   
 $F' = \Sigma(2, 4, 5, 7)$

**2.21** (a)  $F(x, y, z) = \Sigma(2, 5, 6) = \Pi(0, 1, 3, 4, 7)$

(b)  $F(A, B, C, D) = \Pi(0, 1, 2, 4, 7, 9, 12) = \Sigma(3, 5, 6, 8, 10, 11, 13, 14, 15)$

**2.22** (a)  $(AB + C)(B + C'D) = AB + BC + ABC'D + CC'D = AB(1 + C'D) + BC$   
 $= AB + BC$  (SOP form)  
 $= B(A + C)$  (POS form)

(b)  $x' + x(x + y')(y + z') = (x' + x)[x' + (x + y')(y + z')] =$   
 $= (x' + x + y')(x' + y + z')$   
 $= x' + y + z'$

**2.23** (a)  $B'C + AB + ACD$

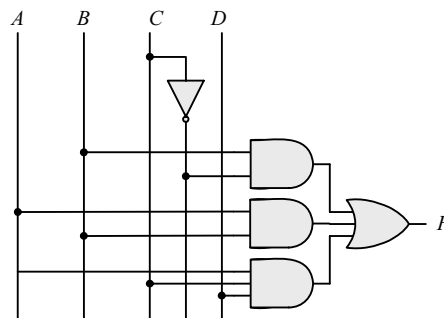

(b)  $(A + B)(C + D)(A' + B + D)$

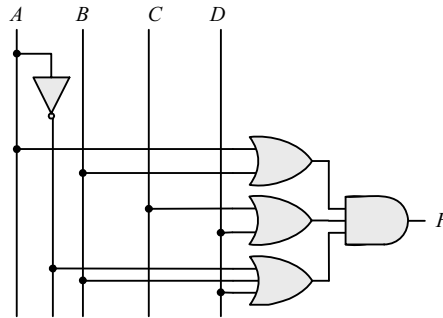

(c)  $(AB + A'B')(CD' + C'D)$

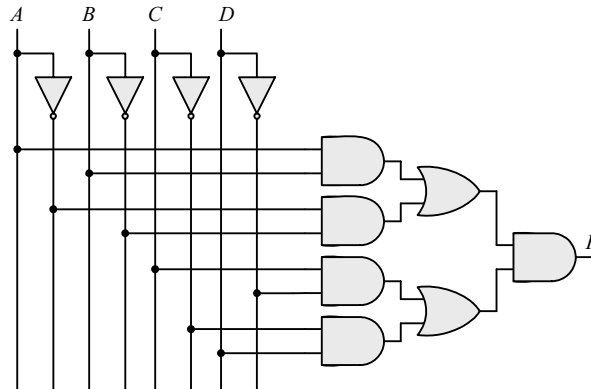

(d)  $A + CD + (A + D')(C' + D)$

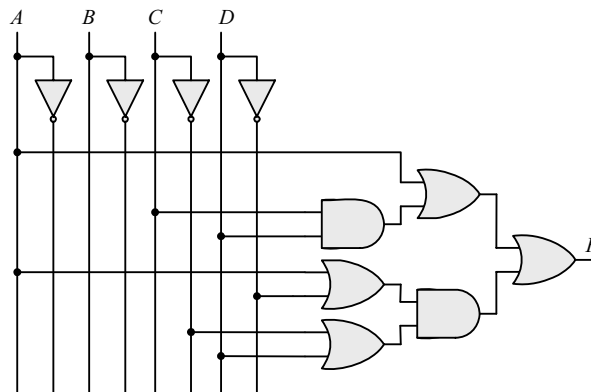

2.24  $x \oplus y = x'y + xy'$  and  $(x \oplus y)' = (x + y')(x' + y)$

Dual of  $x'y + xy' = (x' + y)(x + y') = (x \oplus y)'$

2.25 (a)  $x|y = xy' \neq y|x = x'y$  Not commutative  
 $(x|y)|z = xy'z' \neq x|(y|z) = x(yz)' = xy' + xz$  Not associative

(b)  $(x \oplus y) = xy' + x'y = y \oplus x = yx' + y'x$  Commutative

$(x \oplus y) \oplus z = \Sigma(1, 2, 4, 7) = x \oplus (y \oplus z)$  Associative

2.26

Gate		NAND (Positive logic)		NOR (Negative logic)	
x y	z	x y	z	x y	z
L L	H	0 0	1	1 1	0
L H	H	0 1	1	1 0	0
H L	H	1 0	1	0 1	0
H H	L	1 1	0	0 0	1

Gate		NOR (Positive logic)		NAND (Negative logic)	
x y	z	x y	z	x y	z
L L	H	0 0	1	1 1	0
L H	L	0 1	0	1 0	1
H L	L	1 0	0	0 1	1
H H	L	1 1	0	0 0	1

2.27  $f_1 = a'b'c + a'bc + abc' + abc$

$f_2 = a'bc' + a'bc + ab'c' + ab'c + abc'$

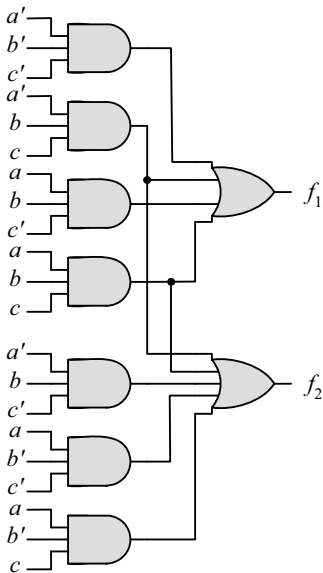

**2.28** (a)  $y = a(bcd)'e = a(b' + c' + d')e$

$$y = a(b' + c' + d')e = ab'e + ac'e + ad'e$$

$$= \Sigma(17, 19, 21, 23, 25, 27, 29)$$

a bcde	y	a bcde	y
0 0000	0	1 0000	0
0 0001	0	<b>1 0001</b>	1
0 0010	0	1 0010	0
0 0011	0	<b>1 0011</b>	1
0 0100	0	1 0100	0
0 0101	0	<b>1 0101</b>	1
0 0110	0	1 0110	0
0 0111	0	<b>1 0111</b>	1
	0		0
0 1000	0	1 1000	0
0 1001	0	<b>1 1001</b>	1
0 1010	0	1 1010	0
0 1011	0	<b>1 1011</b>	1
0 1100	0	1 1100	0
0 1101	0	<b>1 1101</b>	1
0 1110	0	1 1110	0
0 1111	0	1 1111	0

(b)  $y_1 = a \oplus (c + d + e) = a'(c + d + e) + a(c'd'e') = a'c + a'd + a'e + ac'd'e'$

$$y_2 = b'(c + d + e)f = b'cf + b'df + b'ef$$

$$y_1 = a(c + d + e) = a'(c + d + e) + a(c'd'e') = a'c + a'd + a'e + ac'd'e'$$

$$y_2 = b'(c + d + e)f = b'cf + b'df + b'ef$$

$a'-c---$	$a'--d--$	$a'---e-$	$a-c'd'e'-$			
001000 = 8	000100 = 8	000010 = 2	100000 = 32			
001001 = 9	000101 = 9	000011 = 3	100001 = 33			
001010 = 10	000110 = 10	000110 = 6	110000 = 34			
001011 = 11	000111 = 11	000111 = 7	110001 = 35			
001100 = 12	001100 = 12	001010 = 10				
001101 = 13	001101 = 13	001011 = 11				
001110 = 14	001110 = 14	001110 = 14				
001111 = 15	001111 = 15	001111 = 15				
011000 = 24	010100 = 20	010010 = 18	001001 = 9	001001 = 9	000011 = 3	
011001 = 25	010101 = 21	010011 = 19	001011 = 11	001011 = 11	000111 = 7	
011010 = 26	010110 = 22	010110 = 22	001101 = 13	001101 = 13	001011 = 11	
011011 = 27	010111 = 23	010111 = 23	001111 = 15	001111 = 15	001111 = 15	
011100 = 28	011100 = 28	011010 = 26	101001 = 41	101001 = 41	100011 = 35	
011101 = 29	011101 = 29	011001 = 27	101011 = 43	101011 = 43	100111 = 39	
011110 = 30	011110 = 30	011110 = 30	101101 = 45	101101 = 45	101011 = 51	
011111 = 31	011111 = 31	011111 = 31	101111 = 47	101111 = 47	101111 = 55	

$$y_1 = \Sigma (2, 3, 6, 7, 8, 9, 10, 11, 12, 13, 14, 15, 18, 19, 22, 23, 24, 25, 26, 27, 28, 29, 30, 31, 32, 33, 34, 35)$$

$$y_2 = \Sigma (3, 7, 9, 13, 15, 35, 39, 41, 43, 45, 47, 51, 55)$$

<i>ab cdef</i>	$y_1 y_2$	<i>ab cdef</i>	$y_1 y_2$	<i>ab cdef</i>	$y_1 y_2$	<i>ab cdef</i>	$y_1 y_2$
00 0000	0 0	01 0000	0 0	10 0000	1 0	11 0000	0 0
00 0001	0 0	01 0001	0 0	10 0001	1 0	11 0001	0 0
00 0010	1 0	01 0010	1 0	10 0010	1 0	11 0010	0 0
00 0011	1 1	01 0011	1 0	10 0011	1 1	11 0011	0 1
00 0100	0 0	01 0100	0 0	10 0100	0 0	11 0100	0 0
00 0101	0 0	01 0101	0 0	10 0101	0 0	11 0101	0 0
00 0110	1 0	01 0110	1 0	10 0110	0 0	11 0110	0 0
00 0111	1 1	01 0111	1 0	10 0111	0 1	11 0111	0 1
00 1000	1 0	01 1000	1 0	10 1000	0 0	11 1000	0 0
00 1001	1 1	01 1001	1 0	10 1001	0 1	11 1001	0 0
00 1010	1 0	01 1010	1 0	10 1010	0 0	11 1010	0 0
00 1011	1 0	01 1011	1 0	10 1011	0 1	11 1011	0 0
00 1100	1 0	01 1100	1 0	10 1100	0 0	11 1100	0 0
00 1101	1 1	01 1101	1 0	10 1101	0 1	11 1101	0 0
00 1110	1 0	01 1110	1 0	10 1110	0 0	11 1110	0 0
00 1111	1 1	01 1111	1 0	10 1111	0 1	11 1111	0 0

## Chapter 3

### 3.1

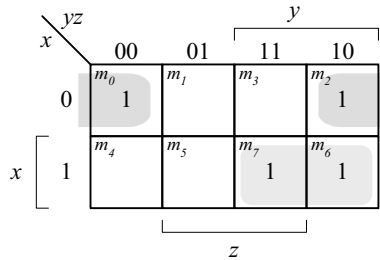

(a)  $F = xy + x'z'$

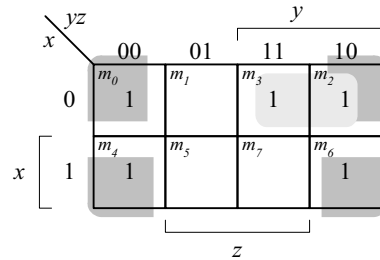

(b)  $F = z' + x'y$

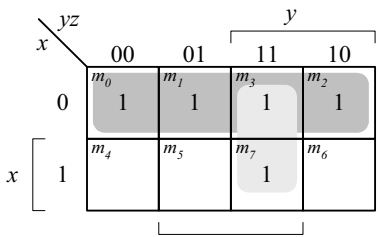

(c)  $F = x' + yz$

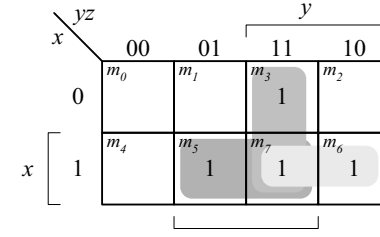

(d)  $F = xy + xz + yz$

### 3.2

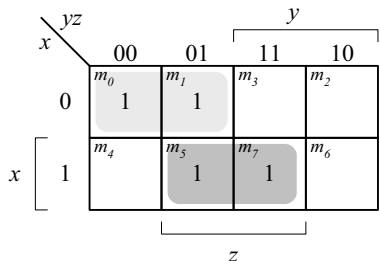

(a)  $F = x'y' + xz$

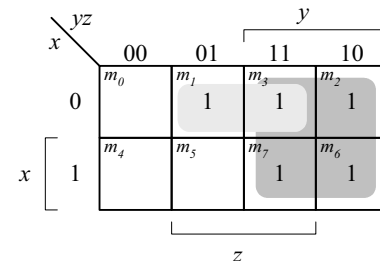

(b)  $F = y + x'z$

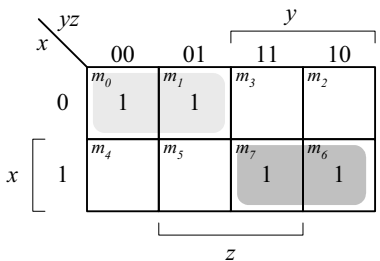

(c)  $F = x'y' + xy$

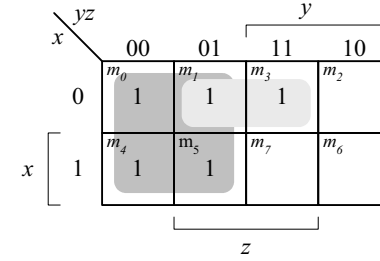

(d)  $F = y' + x'z$



		y			
		00	01	11	10
x	yz	$m_0$	$m_1$	$m_3$	$m_2$
	0		1	1	
x	yz	$m_4$	$m_5$	$m_7$	$m_6$
	1		1	1	
		z			

(e)  $F = z$

		y			
		00	01	11	10
x	yz	$m_0$	$m_1$	$m_3$	$m_2$
	0		1		
x	yz	$m_4$	$m_5$	$m_7$	$m_6$
	1	1	1	1	1
		z			

(f)  $F = x + y'z$

3.3

		y			
		00	01	11	10
x	yz	$m_0$	$m_1$	$m_3$	$m_2$
	0	1			1
x	yz	$m_4$	$m_5$	$m_7$	$m_6$
	1			1	1
		z			

(a)  $F = xy + x'y'z' + x'yz'$   
 $F = xy + x'z'$

		y			
		00	01	11	10
x	yz	$m_0$	$m_1$	$m_3$	$m_2$
	0	1	1	1	1
x	yz	$m_4$	$m_5$	$m_7$	$m_6$
	1			1	
		z			

(b)  $F = x'y' + yz + x'yz'$   
 $F = x' + yz$

		y			
		00	01	11	10
x	yz	$m_0$	$m_1$	$m_3$	$m_2$
	0	1		1	1
x	yz	$m_4$	$m_5$	$m_7$	$m_6$
	1	1			1
		z			

(c)  $F = x'y + yz' + y'z'$   
 $F = x'y + z'$

		y			
		00	01	11	10
x	yz	$m_0$	$m_1$	$m_3$	$m_2$
	0		1		
x	yz	$m_4$	$m_5$	$m_7$	$m_6$
	1			1	1
		z			

(d)  $F = xyz + x'y'z + xyz'$   
 $F = x'y'z + xy$

3.4

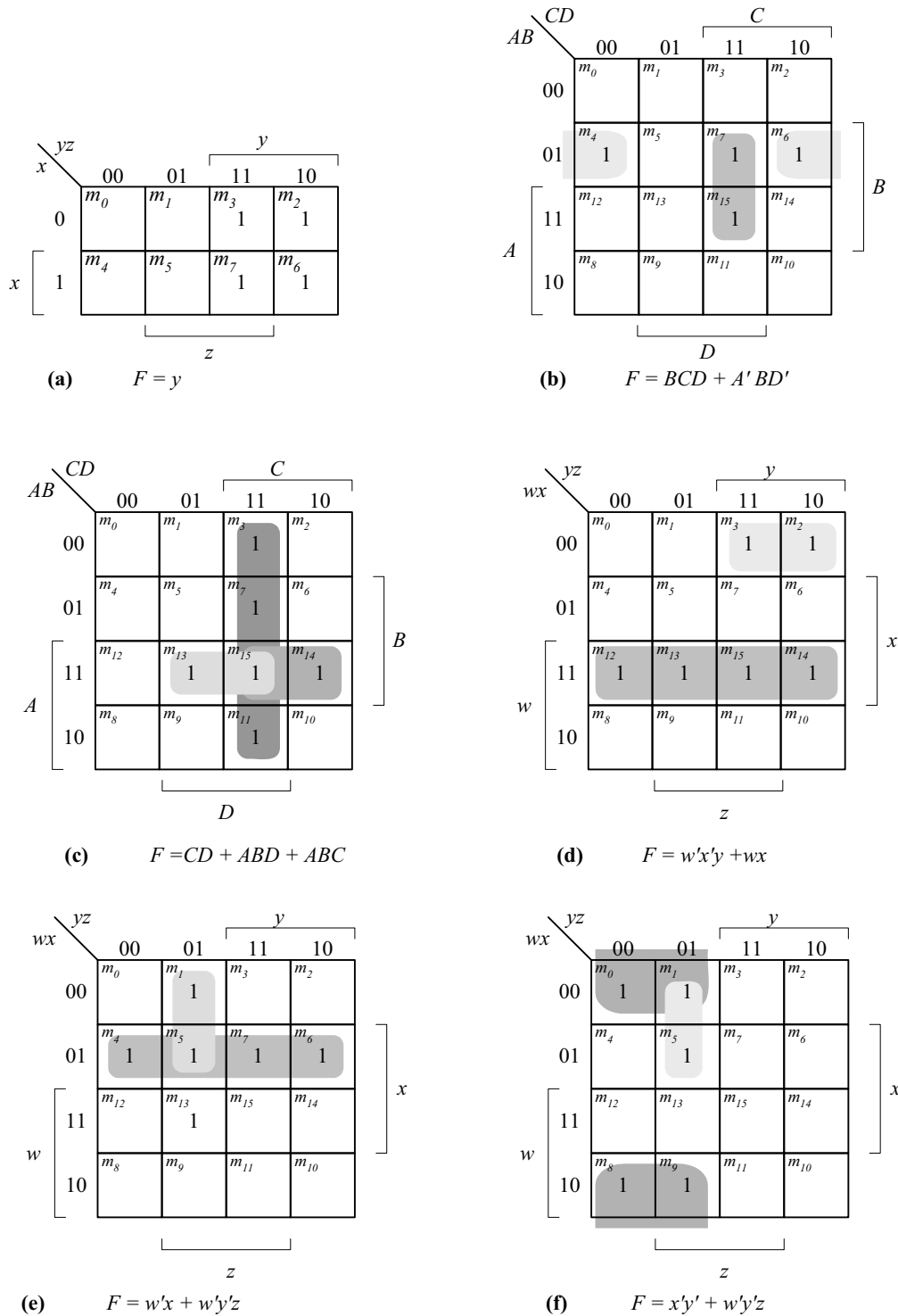

3.5

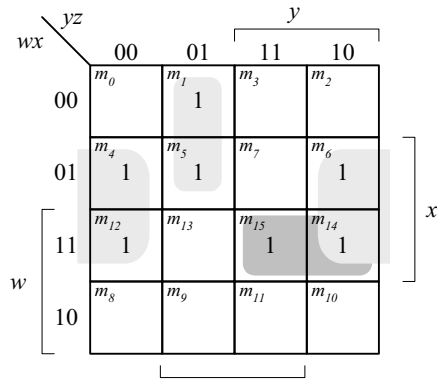

(a)  $F = xz' + w'y'z + wx y$

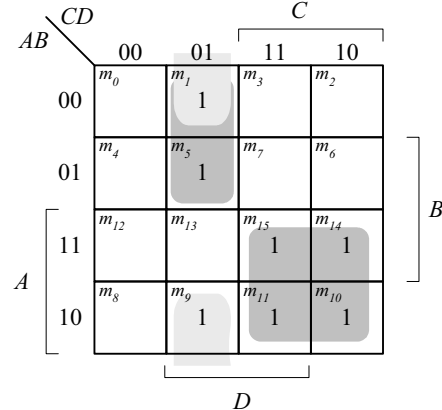

(b)  $F = A'C + A'C'D + B'C'D$

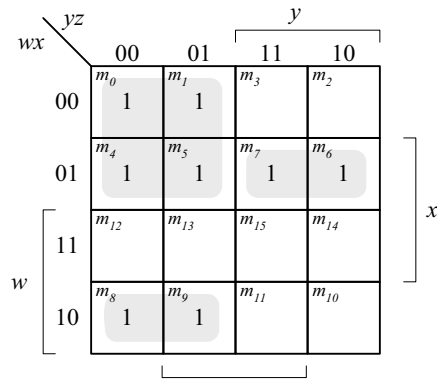

(c)  $F = w'y' + wx'y' + w'xy$

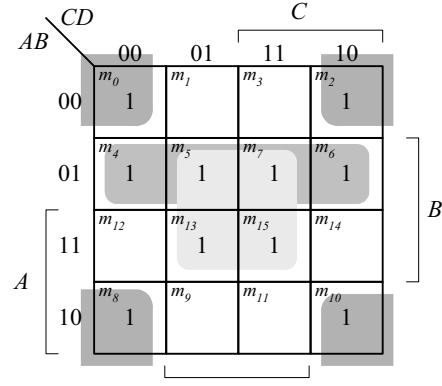

(d)  $F = BD + A'B + B'D'$   
or  $= BD + B'D' + A'D'$

3.6

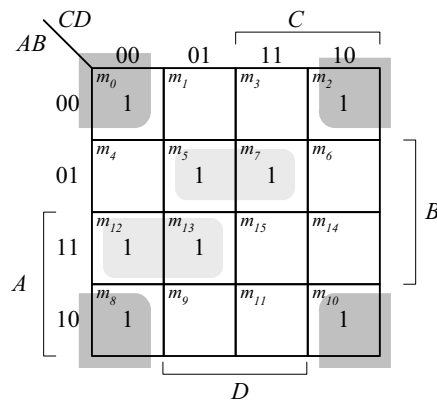

(a)  $F = B'D' + A'BD + ABC'$

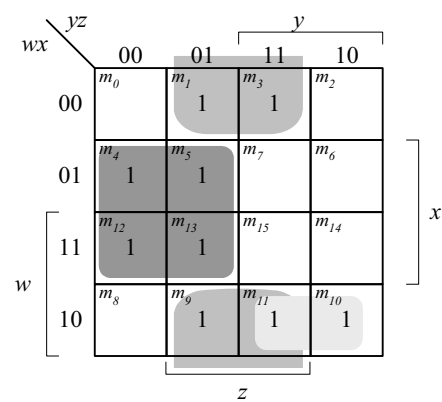

(b)  $F = xy' + x'z + wx'y$

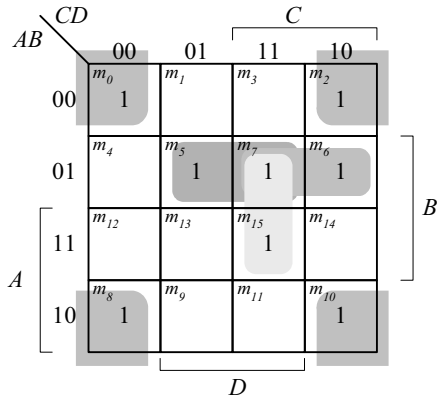

(c)  $F = B'D' + BCD + A'BD + A'BC$

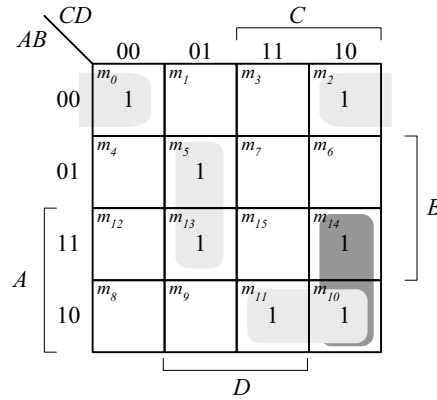

(d)  $F = A'B'D' + BC'D + ACD' + AB'C$

3.7

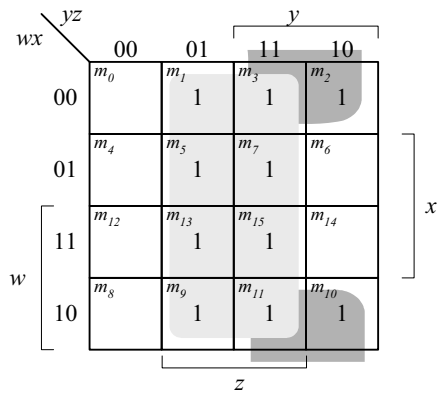

(a)  $F = z + x'y$

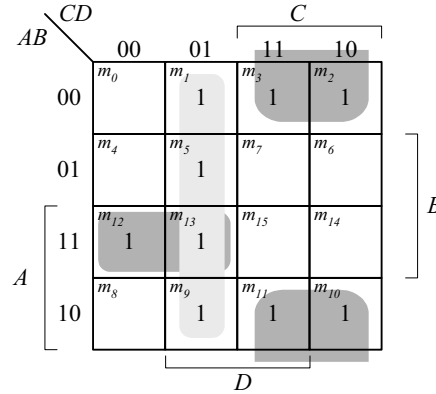

(b)  $F = C'D + B'C + ABC'$

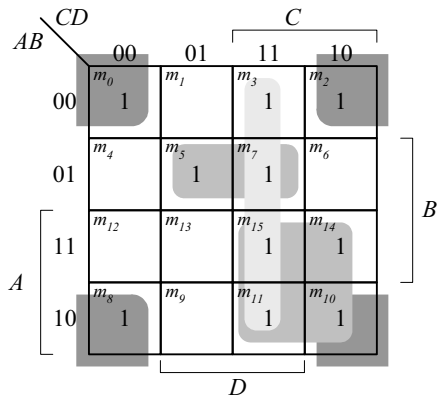

(c)  $F = B'D' + AC + A'BD + CD$  (or  $B'C$ )

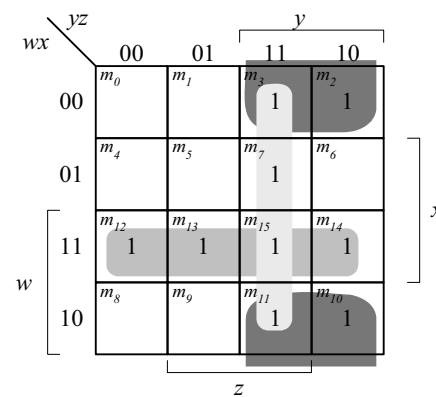

(d)  $F = wx + x'y + yz$

3.8

(a)  $F(x, y, z) = \Sigma(3, 5, 6, 7)$

		y			
		00	01	11	10
x	0	$m_0$	$m_1$	$m_3$ 1	$m_2$
	1	$m_4$	$m_5$ 1	$m_7$ 1	$m_6$ 1
		z			

(b)  $F = \Sigma(1, 3, 5, 9, 12, 13, 14)$

		C			
		00	01	11	10
A	00	$m_0$	$m_1$ 1	$m_3$ 1	$m_2$
	01	$m_4$	$m_5$ 1	$m_7$	$m_6$
	11	$m_{12}$ 1	$m_{13}$ 1	$m_{15}$	$m_{14}$ 1
	10	$m_8$	$m_9$ 1	$m_{11}$	$m_{10}$
		D			

(c)  $F = \Sigma(0, 1, 2, 3, 11, 12, 14, 15)$

		y			
		00	01	11	10
w	00	$m_0$ 1	$m_1$ 1	$m_3$ 1	$m_2$ 1
	01	$m_4$	$m_5$	$m_7$	$m_6$
	11	$m_{12}$ 1	$m_{13}$	$m_{15}$ 1	$m_{14}$ 1
	10	$m_8$	$m_9$	$m_{11}$ 1	$m_{10}$
		z			

(d)  $F = \Sigma(3, 4, 5, 7, 11, 12)$

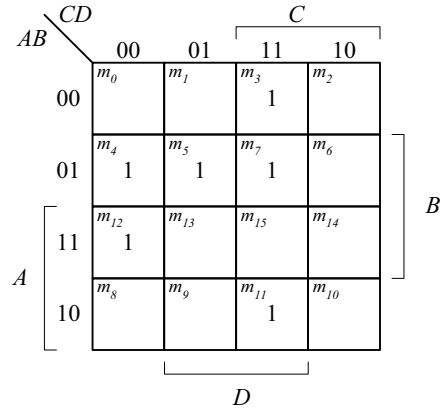

3.9

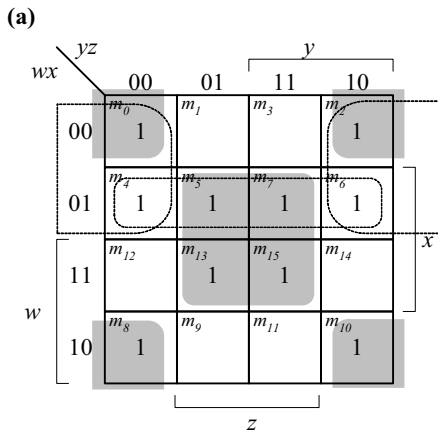

**Essential:**  $xz, x'z'$   
**Non-essential:**  $w'x, w'z'$   
 $F = xz + x'z' + (w'x \text{ or } w'z')$

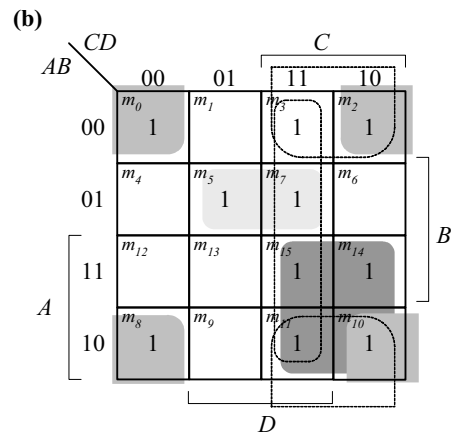

**Essential:**  $B'D', AC, A'BD$   
**Non-essential:**  $CD, B'C$   
 $F = B'D' + AC + A'BD + (CD \text{ OR } B'C)$

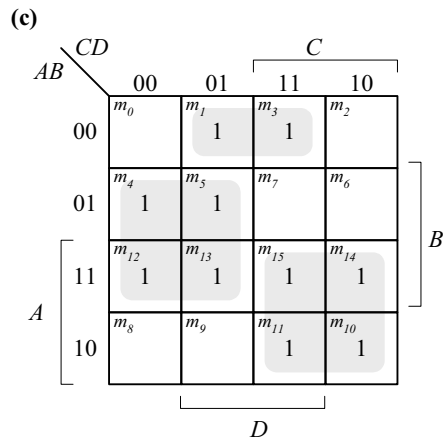

**Essential:**  $BC', AC, A'B'D$   
 $F = BC' + AC + A'B'D$

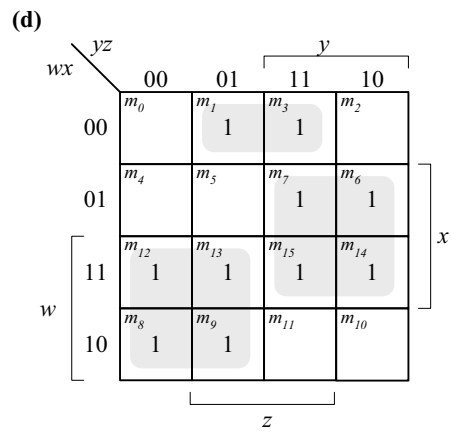

**Essential:**  $wy', xy, w'x'z$   
 $F = wy' + xy + w'x'z$

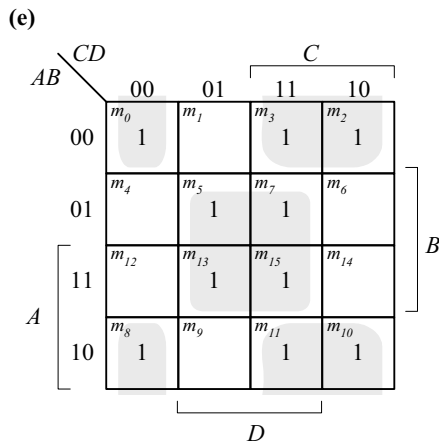

**Essential:**  $BD, B'C, B'C'D'$   
 $F = BD + B'C + B'C'D'$

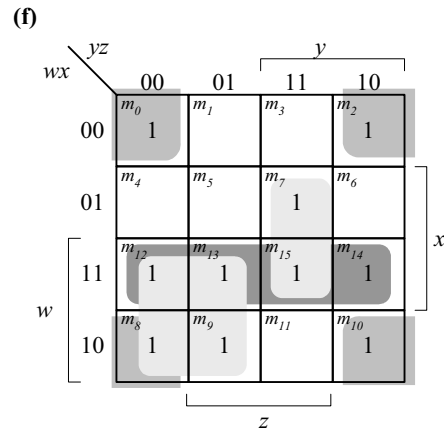

**Essential:**  $wy', wx, x'z', xyz$   
 $F = wy' + wx + x'z' + xyz$

3.10

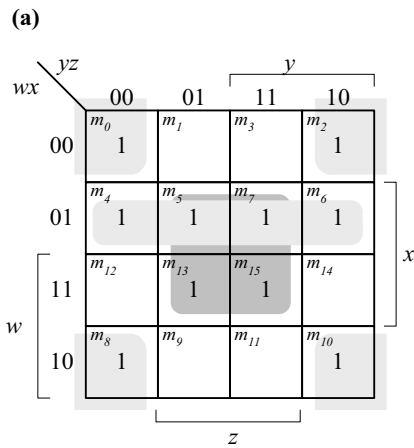

**Essential:**  $xz, w'x, x'z'$   
 $F = xz + w'x + x'z'$

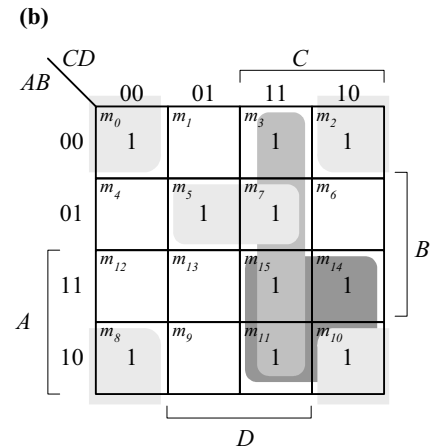

**Essential:**  $AC, B'D', CD, A'BD$   
 $F = AC + B'D' + CD + A'BD$

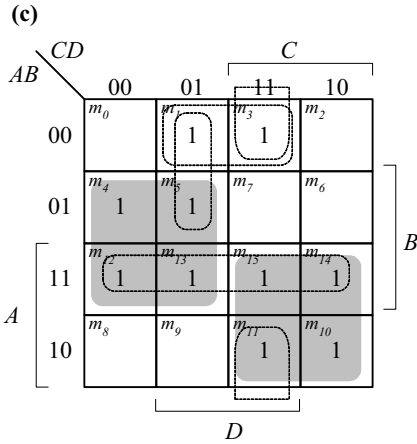

**Essential:**  $BC'$ ,  $AC$   
**Non-essential:**  $AB$ ,  $A'B'D$ ,  $B'CD$ ,  $A'C'D$   
 $F = BC' + AC + A'B'D$

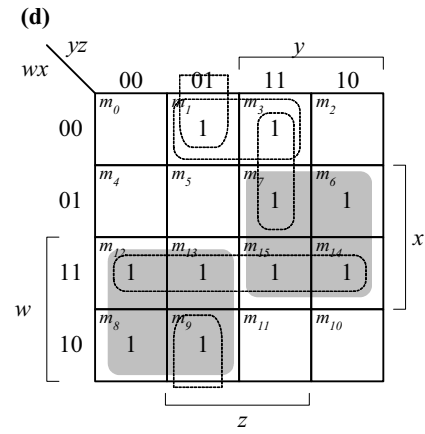

**Essential:**  $wy'$ ,  $xy$   
**Non-essential:**  $wx$ ,  $x'y'z$ ,  $w'wz$ ,  $w'x'z$   
 $F = wy' + xy + w'x'z$

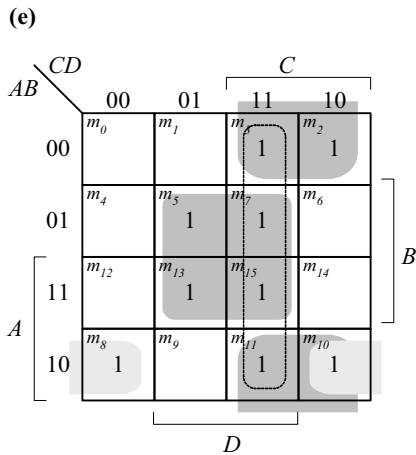

**Essential:**  $BD$ ,  $B'C$ ,  $AB'C$   
**Non-essential:**  $CD$   
 $F = BD + B'C + AB'C$

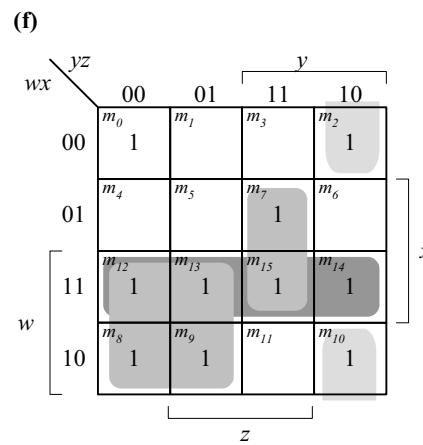

**Essential:**  $wy'$ ,  $wx$ ,  $xyz$ ,  $x'yz'$   
 $F = wy' + wx + xyz + x'yz'$



3.11 (a)  $F(A, B, C, D, E) = \sum (0, 1, 4, 5, 16, 17, 21, 25, 29)$

$$F = A'B'D' + AD'E + B'C'D'$$

- $m_0: A'B'C'D'E' = 00000$
- $m_1: A'B'C'D'E = 00001$
- $m_4: A'B'CD'E' = 00100$
- $m_5: A'B'CD'E = 00101$
- $m_{16}: AB'C'D'E' = 10000$
- $m_{17}: AB'C'D'E = 10001$
- $m_{21}: AB'CD'E = 10101$
- $m_{25}: ABC'D'E = 11001$
- $m_{29}: ABCD'E = 11101$

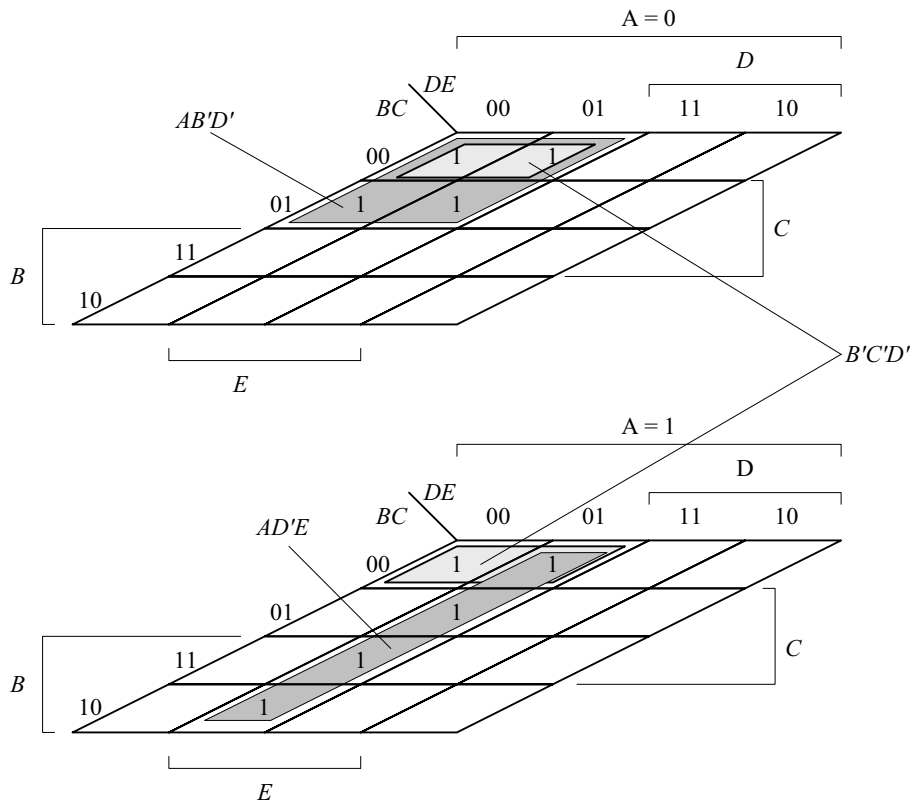

(b)  $F(A, B, C, D, E) = A'B'CE' + B'C'D'E' + A'B'D' + B'CD' + A'CD + A'BD$   
 $F(A, B, C, D, E) = A'B'D' + B'D'E' + B'CD' + A'CD + A'BD$

- $A'B'CE'$ :  $AB'CDE' + A'B'CD'E'$
- $B'C'D'E'$ :  $AB'C'D'E' + A'B'CD'E'$
- $A'B'D'$ :  $A'B'CD'E + A'B'CD'E' + A'B'C'D'E + A'B'C'D'E'$
- $B'CD'$ :  $AB'CD'E + AB'CD'E' + A'B'CD'E + A'B'CD'E'$
- $A'CD$ :  $A'BCDE + A'BCDE' + A'B'CDE + A'B'CDE'$
- $A'BD$ :  $A'BCDE + A'BCDE' + A'BC'DE + A'BC'DE'$

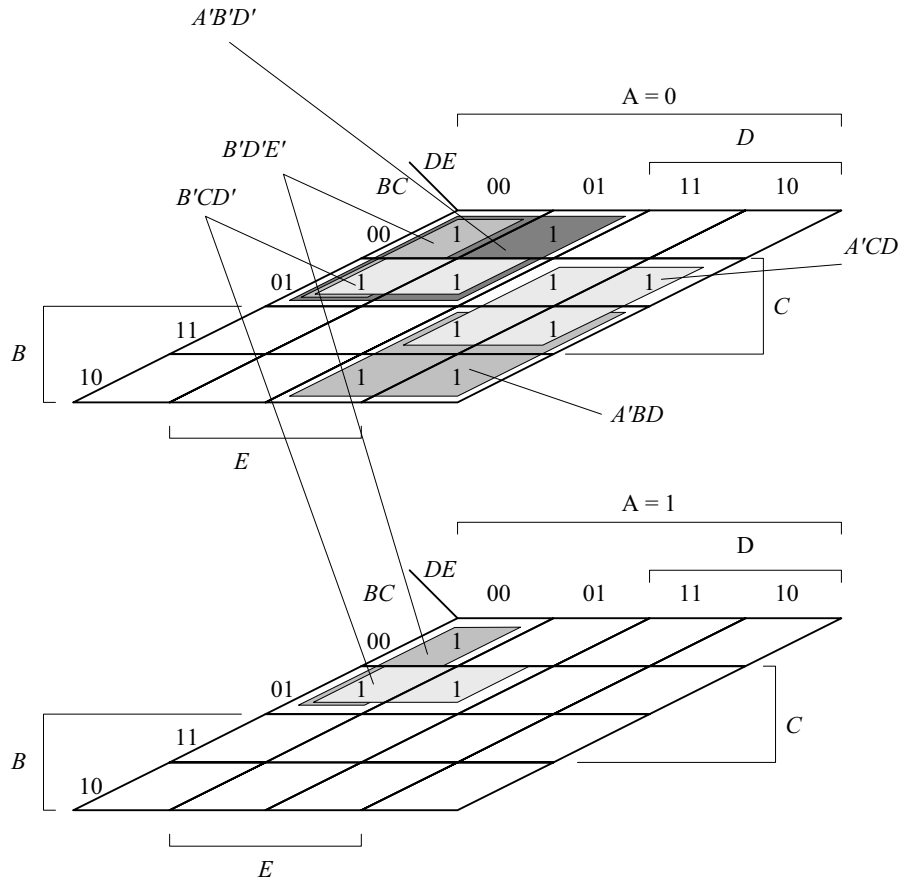

3.12

(a)

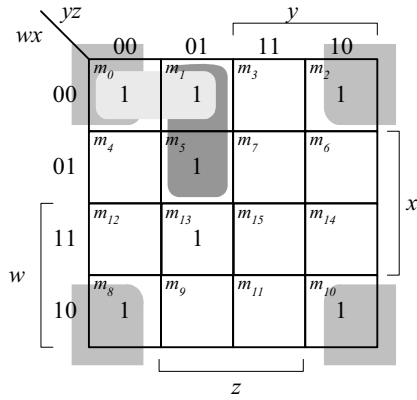

$$F = \Sigma(0, 1, 2, 5, 8, 10, 13)$$

$$F = x'z' + w'x'y' + w'y'z$$

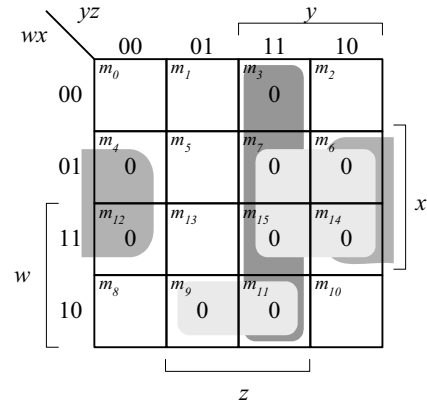

$$F' = yz + xz' + xy + wx'z$$

$$F = (y' + z')(x' + z)(x' + y')(w' + x + z')$$

(b)

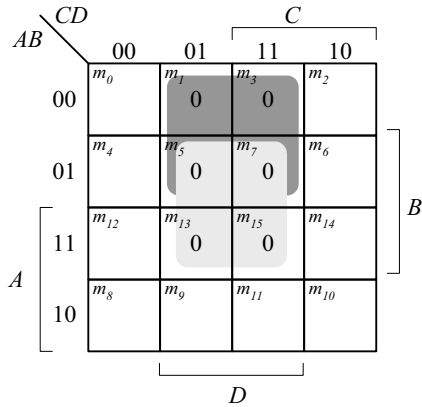

$$F = \Pi(1, 3, 5, 7, 13, 15)$$

$$F' = A'D + B'D$$

$$F = (A + D)(B' + D')$$

$$F = C'D' + AB' + CD'$$

(c)

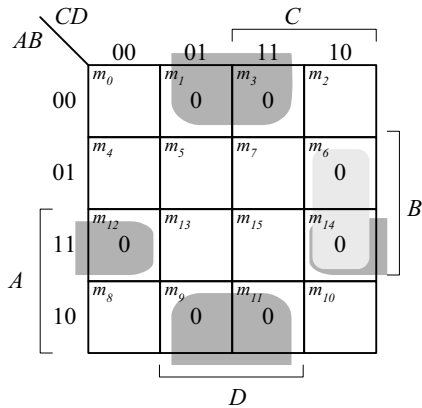

$$F = \Pi(1, 3, 6, 9, 11, 12, 14)$$

$$F' = B'D + BCD' + ABD'$$

$$F = (B + D')(B' + C' + D)(A' + B' + D)$$

$$F = BD + B'D' + A'CD'$$

3.13 (a)  $F = xy + z' = (x + z')(y + z')$

(b)

		CD				
		C		D		
A	AB	00	01	11	10	B
		$m_0$	$m_1$	$m_3$	$m_2$	
	00	0	1	0	0	
	$m_4$	$m_5$	$m_7$	$m_6$		
01	0	1	0	0		
11	$m_{12}$	$m_{13}$	$m_{15}$	$m_{14}$		
10	$m_8$	$m_9$	$m_{11}$	$m_{10}$		
		D				

$$F = AC' + AD + C'D + AB'C$$

		CD				
		C		D		
A	AB	00	01	11	10	B
		$m_0$	$m_1$	$m_3$	$m_2$	
	00	0	1	0	0	
	$m_4$	$m_5$	$m_7$	$m_6$		
01	0	1	0	0		
11	$m_{12}$	$m_{13}$	$m_{15}$	$m_{14}$		
10	$m_8$	$m_9$	$m_{11}$	$m_{10}$		
		D				

$$F' A'D' + A'C + BCD'$$

$$F = (A + D)(A + C')(B' + C' + D)$$

(c)

		CD				
		C		D		
A	AB	00	01	11	10	B
		$m_0$	$m_1$	$m_3$	$m_2$	
	00			0		
	$m_4$	$m_5$	$m_7$	$m_6$		
01			0			
11	$m_{12}$	$m_{13}$	$m_{15}$	$m_{14}$		
10	$m_8$	$m_9$	$m_{11}$	$m_{10}$		
		D				

$$F = (A + C' + D')(A' + B' + D')(A' + B + D')(A' + B + C')$$

$$F' = A'CD + ABD + AB'D + AB'C$$

$$F = A'C + A'D' + BD' + C'D'$$

$$F' = AD + CD + AB'C$$

$$F = (A' + D')(C + D)(A' + B + C')$$

		CD				
		C		D		
A	AB	00	01	11	10	B
		$m_0$	$m_1$	$m_3$	$m_2$	
	00	1	1		1	
	$m_4$	$m_5$	$m_7$	$m_6$		
01	1	1		1		
11	$m_{12}$	$m_{13}$	$m_{15}$	$m_{14}$		
10	$m_8$	$m_9$	$m_{11}$	$m_{10}$		
		D				

(d)

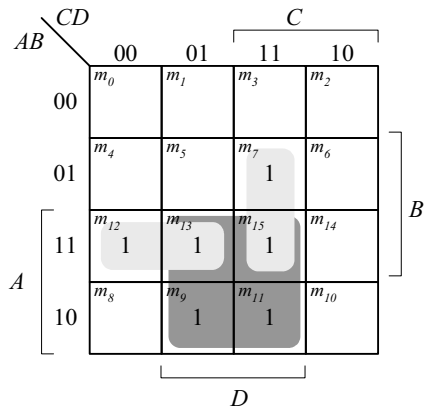

$$F = ABC' + AB'D + BCD$$

$$F = AD + ABC' + BCD$$

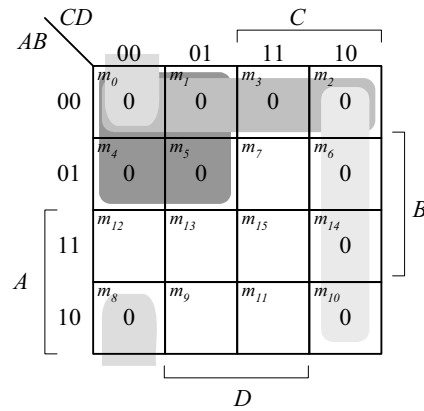

$$F' = A'C' + A'B' + CD' + B'C'D'$$

$$F = (A + C)(A + B)(C' + D)(B + C + D)$$

3.14

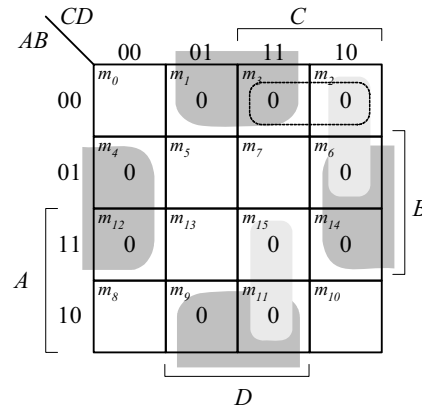
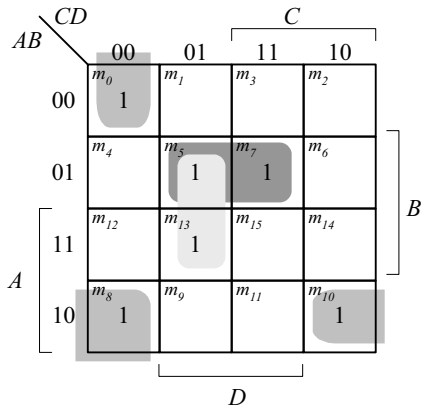

SOP form (using 1s):  $F = B'C'D' + AB'D' + BC'D + A'BD$   
 $F = B'D'(A + C') + BD(A' + C')$

POS form (using 0s):  $F' = BD' + B'D + A'CD' + ACD$   
 $F = [(B' + D)(B + D)][(A + C' + D)(A' + C' + D)']$

Alternative POS:  $F' = BD' + B'D + A'CD' + A'B'C$   
 $F = [(B' + D)(B + D)][(A + C' + D)(A' + B + C)']$

3.15

(a)

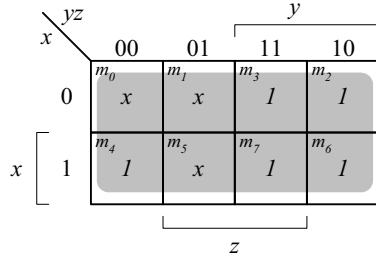

$$F = 1$$

$$F = \Sigma(0,1, 2, 3, 4, 5, 6, 7)$$

(b)

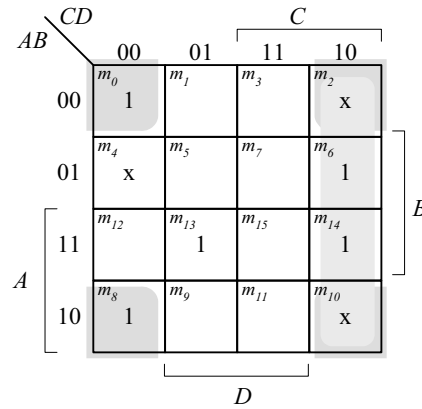

$$F = B'D' + ABC'D$$

$$F = \Sigma(0, 2, 6, 8, 10, 13, 14)$$

(c)

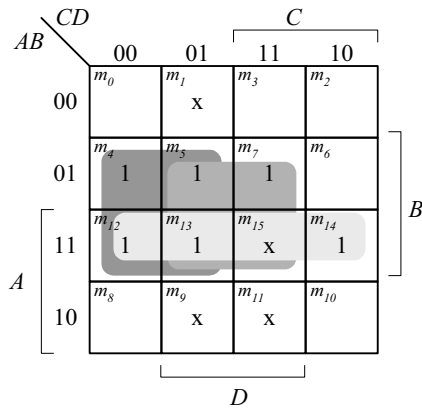

$$F = BC' + BD + AB$$

$$F = \Sigma(4, 5, 7, 12, 13, 14, 15)$$

(d)

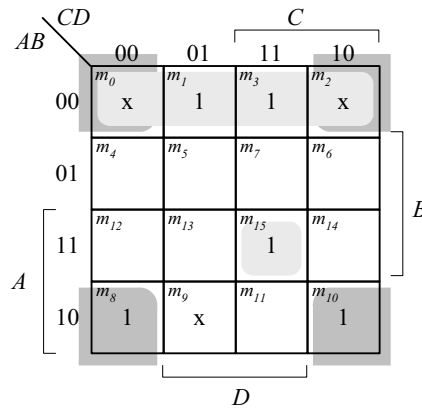

$$F = B'D' + A'B' + ABCD$$

$$F = \Sigma(0, 1, 2, 3, 8, 10, 15)$$

3.16

(a)

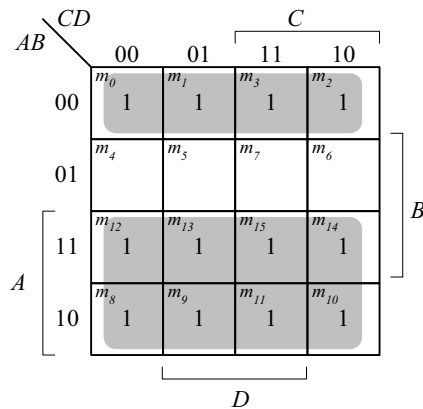

$$F = A + A'B'$$

$$F = (A'(A'B'))'$$

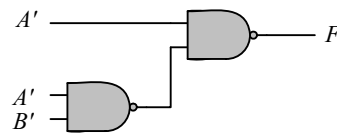

(b)

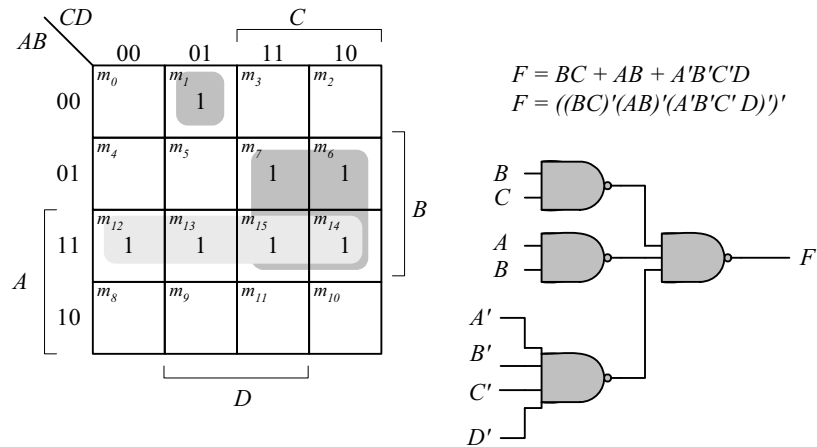

(c)

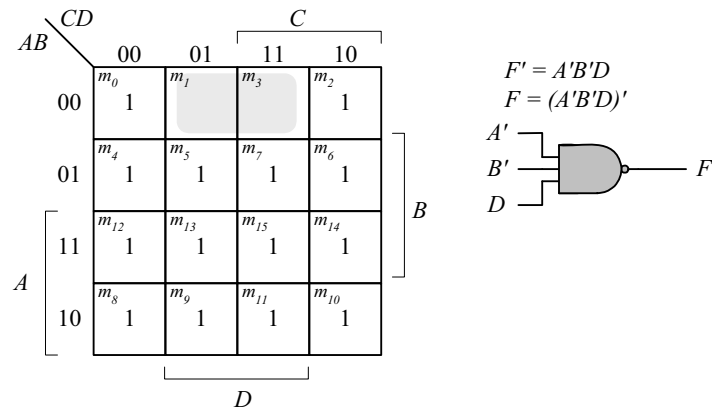

(d)

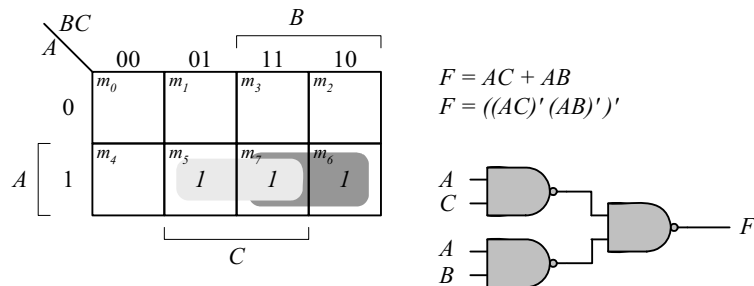

3.17

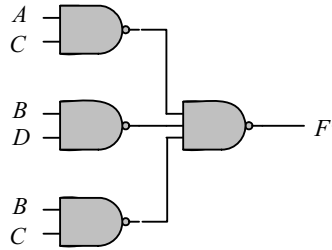
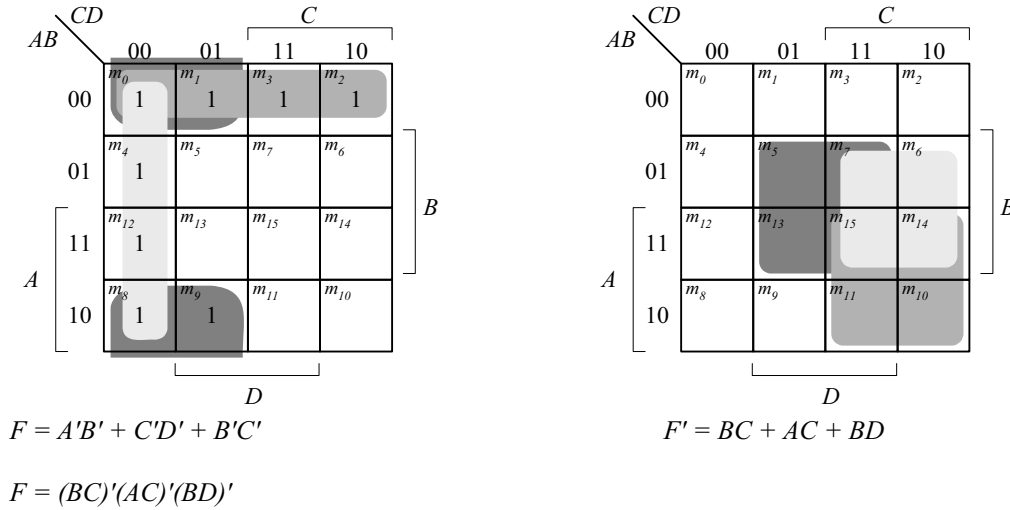

**3.18**  $F = (A \oplus B)'(C \oplus D) = (A'B' + A'B)(C'D' + C'D) = AB'CD' + AB'C'D + A'BCD' + A'BC'D$

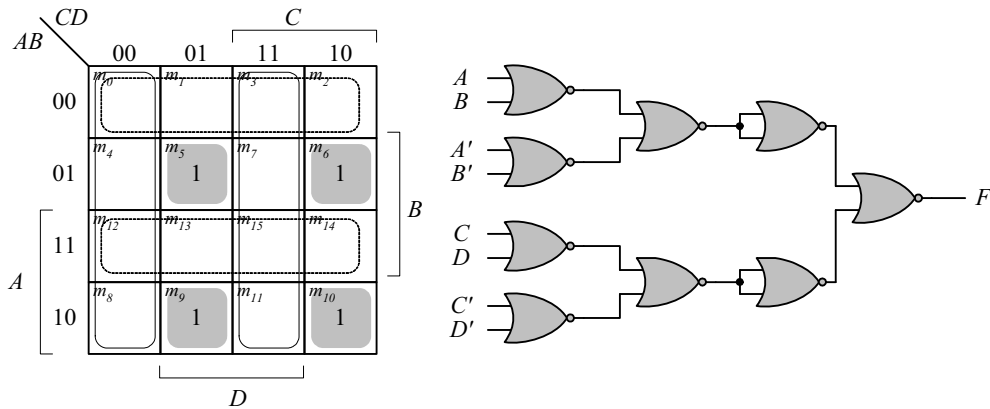

$F = AB'CD' + AB'C'D + A'BCD' + A'BC'D$  and  $F' = A'B' + AB + C'D' + CD$   
 $F = (A'B')(AB)'(C'D)')(CD)' = (A + B)(A' + B') (C' + D')(C + D)$   
 $F' = [(A + B)(A' + B')] + [(C' + D')(C + D)]'$   
 $F = [(A + B)(A' + B')] + [(C' + D')(C + D)]'$   
 $F = [(A + B)' + (A' + B)'] + [(C' + D)'+ (C + D)']'$



**3.19 (a)**  $F = (w + z')(x' + z')(w' + x' + y')$

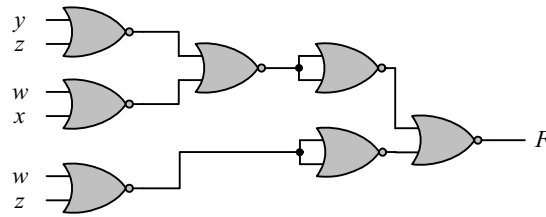
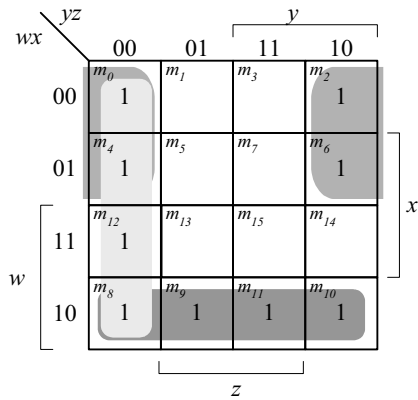

$$F = y'z' + wx' + w'z'$$

$$F = [(y + z)' + (w' + x)' + (w + z)']$$

$$F' = [(y + z)' + (w' + x)' + (w + z)']'$$

**(b)**

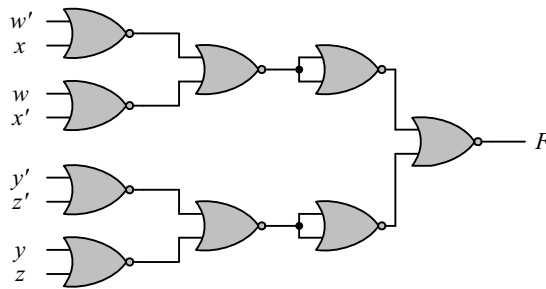
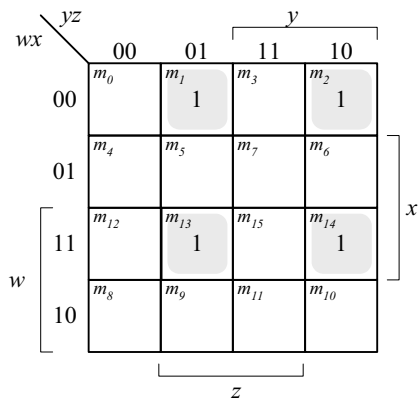

$$F = \Sigma(1, 2, 13, 14)$$

$$F' = w'x + wx' + y'z' + yz = [(w + x')(w' + x)(y + z)(y' + z)']'$$

$$F = (w + x')' + (w' + x)' + (y + z)' + (y' + z)'$$

**(c)**  $F = [(x + y)(x' + z)]' = (x + y)' + (x' + z)'$   
 $F' = [(x + y)' + (x' + z)']'$

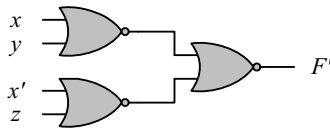

**3.20**

Multi-level NOR:

$$F = (AB' + CD'E) + BC(A + B)$$

$$F' = [(AB' + CD'E) + BC(A + B)]'$$

$$F' = [ [(AB' + CD'E)' + E']' + [ (BC)' + (A + B)']' ]'$$

$$F' = [ [((A' + B)' + (C' + D)')' + E']' + [ (B' + C)' + (A + B)']' ]'$$

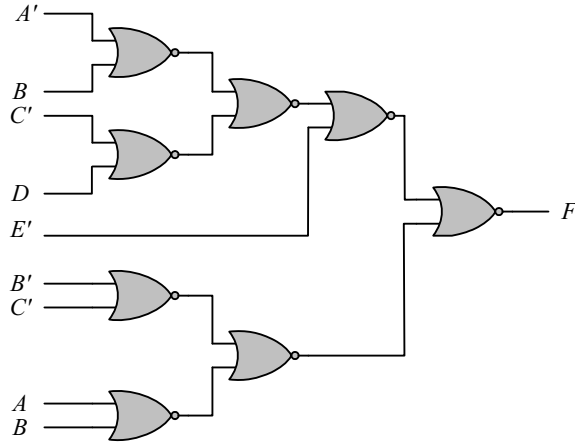

Multi-level NAND:

$$F = (AB' + CD')E + BC(A + B)$$

$$F' = [(AB' + CD')E]' [BC(A + B)]'$$

$$F' = [((AB')'(CD')')E]' [BC(A'B)']$$

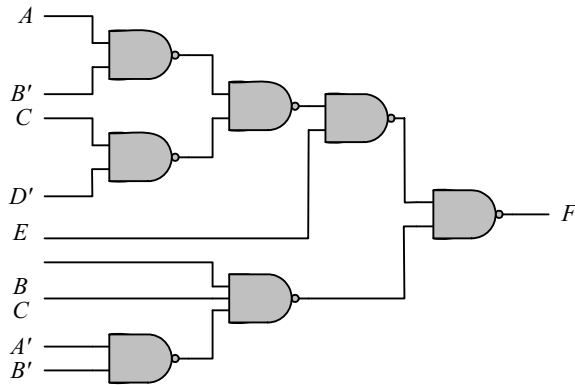

3.21

$$F = w(x + y + z) + xyz$$

$$F' = [w(x + y + z)][xyz]' = [w(x'y'z')]'(xyz)'$$

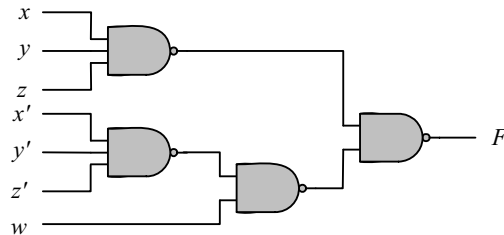

3.22

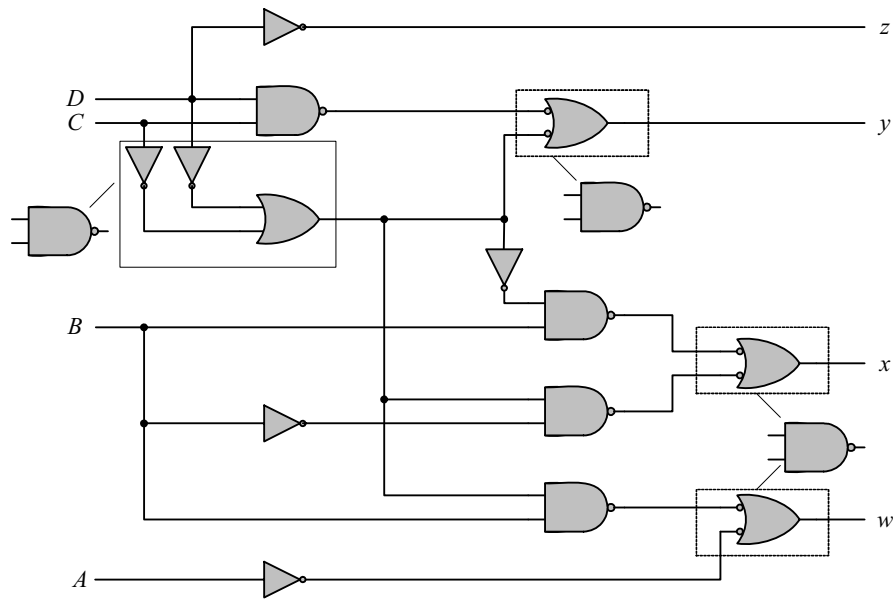

3.23

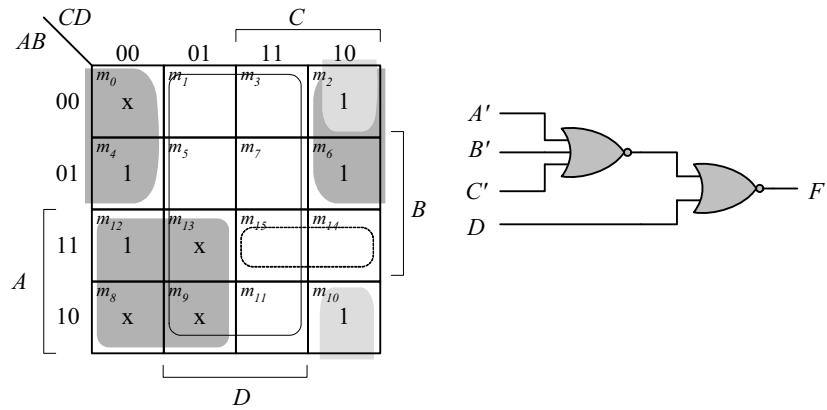

$$F = AC' + A'D' + B'CD'$$

$$F' = D + ABC$$

$$F = [D + ABC]' = [D + (A' + B' + C')]'$$

3.24

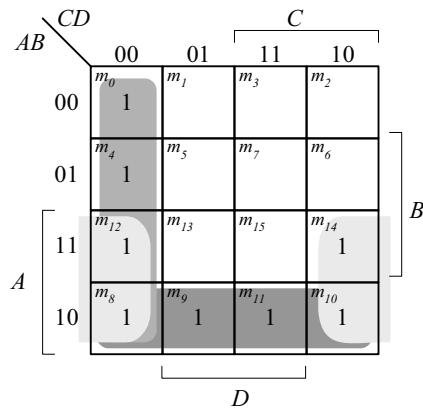

(a)  $F = C'D' + AB' + AD'$

$$F' = (C'D')'(AB)'(AD)'$$

AND-NAND:

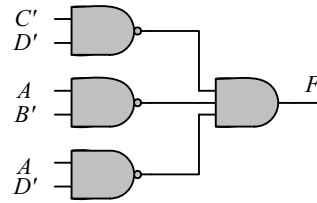

(b)  $F' = [C'D' + AB' + AD']'$   
AND-NOR:

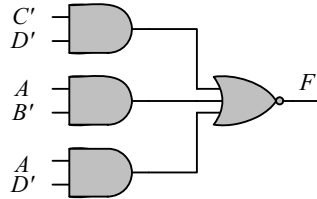

(c)  $F = C'D' + AB' + AD' = (C + D)' + (A' + B)' + (A' + D)'$   
 $F' = (C'D')'(AB)'(AD)' = (C + D)(A' + B)(A' + D)$   
 $F = [(C + D)(A' + B)(A' + D)]'$   
 OR-NAND:

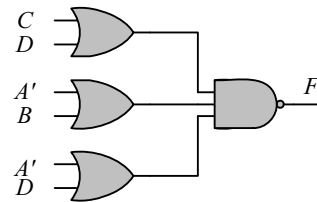

(d)  $F = C'D' + AB' + AD' = (C + D)' + (A' + B)' + (A' + D)'$   
 NOR-OR:

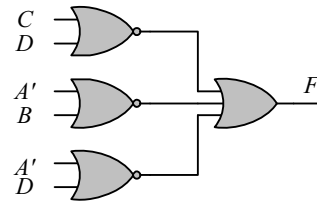

3.25

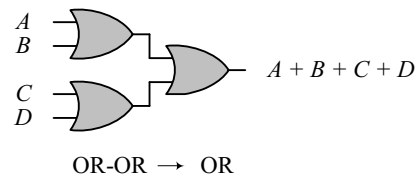
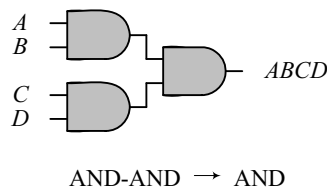

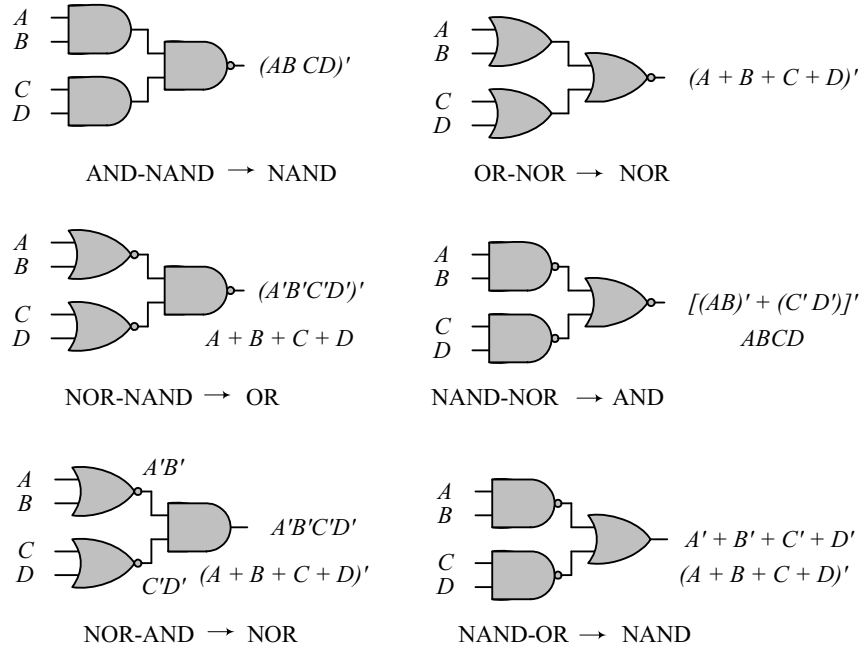

The degenerate forms use 2-input gates to implement the functionality of 4-input gates.

3.26

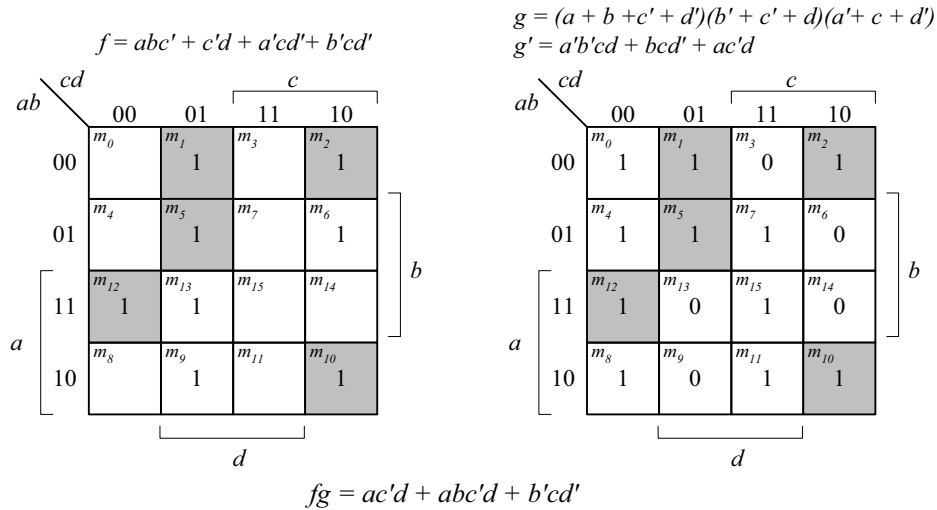

3.27

$x \oplus y = x'y + xy'$ ; Dual =  $(x' + y)(x + y) = (x \oplus y)'$

3.28

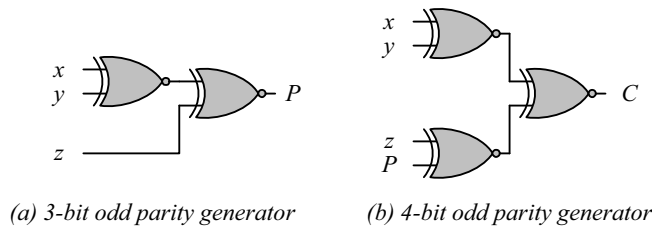

3.29

$$D = A \oplus B \oplus C$$

$$E = A'BC + AB'C = (A \oplus B)C$$

$$F = ABC' + (A' + B')C = ABC' + (AB)'C = (AB) \oplus C$$

$$G = ABC$$

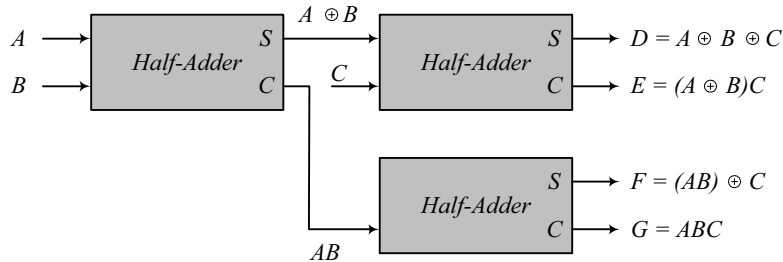

3.30

$$F = AB'CD' + A'BCD' + AB'C'D + A'BC'D$$

$$F = (A \oplus B)CD' + (A \oplus B)C'D = (A \oplus B)(C \oplus D)$$

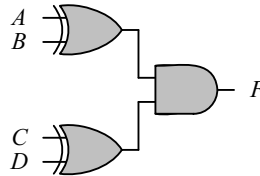

3.31

Note: It is assumed that a complemented input is generated by another circuit that is not part of the circuit that is to be described.

(a) **module** Fig\_3\_22a\_gates (F, A, B, C, C\_bar, D);  
**output** F;  
**input** A, B, C, C\_bar, D;  
**wire** w1, w2, w3, w4;  
**and** (w1, C, D);  
**or** (w2, w1, B);  
**and** (w3, w2, A);  
**and** (w4, B, C\_bar);  
**or** (F, w3, w4);  
**endmodule**

(b) **module** Fig\_3\_22b\_gates (F, A, B, C, C\_bar, D);  
**output** F;  
**input** A, B, C, C\_bar, D;  
**wire** w1, w2, w3, w4;  
**not** (w1\_bar, w1);  
**not** (B\_bar, B);  
**not** (w3\_bar, w3);  
**not** (w4\_bar, w4);  
**nand** (w1, C, D);  
**or** (w2, w1\_bar, B\_bar);  
**nand** (w3, w2, A);  
**nand** (w4, B, C\_bar);  
**or** (F, w3\_bar, w4\_bar);  
**endmodule**

- (c) **module** Fig\_3\_23a\_gates (F, A, A\_bar, B, B\_bar, C, D\_bar);  
    **output** F;  
    **input** A, A\_bar, B, B\_bar, C, D\_bar;  
    **wire** w1, w2, w3, w4;  
    **and** (w1, A, B\_bar);  
    **and** (w2, A\_bar, B);  
    **or** (w3, w1, w2);  
    **or** (w4, C, D\_bar);  
    **or** (F, w3, w4);  
**endmodule**
- (d) **module** Fig\_3\_23b\_gates (F, A, A\_bar, B, B\_bar, C\_bar, D);  
    **output** F;  
    **input** A, A\_bar, B, B\_bar, C\_bar, D;  
    **wire** w1, w2, w3, w4;  
    **nand** (w1, A, B\_bar);  
    **nand** (w2, A\_bar, B);  
    **not** (w1\_bar, w1);  
    **not** (w2\_bar, w2);  
    **or** (w3, w1\_bar, w2\_bar);  
    **or** (w4, C, D\_bar);  
    **not** (w5, C\_bar);  
    **not** (w6, D);  
    **nand** (F\_bar, w5, w6);  
    **not** (F, F\_bar);  
**endmodule**
- (e) **module** Fig\_3\_26\_gates (F, A, B, C, D, E\_bar);  
    **output** F;  
    **input** A, B, C, D, E\_bar;  
    **wire** w1, w2, w1\_bar, w2\_bar, w3\_bar;  
    **not** (w1\_bar, w1);  
    **not** (w2\_bar, w2);  
    **not** (w3\_bar, E\_bar);  
    **nor** (w1, A, B);  
    **nor** (w2, C, D);  
    **nand** (F, w1\_bar, w2\_bar, w3\_bar);  
**endmodule**
- (f) **module** Fig\_3\_27\_gates (F, A, A\_bar, B, B\_bar, C, D\_bar);  
    **output** F;  
    **input** A, A\_bar, B, B\_bar, C, D\_bar;  
    **wire** w1, w2, w3, w4, w5, w6, w7, w8, w7\_bar, w8\_bar;  
    **not** (w1, A\_bar);  
    **not** (w2, B\_bar);  
    **not** (w3, A);  
    **not** (w4, B\_bar);  
    **not** (w7\_bar, w7);  
    **not** (w8\_bar, w8);  
    **and** (w5, w1, w2);  
    **and** (w6, w3, w4);  
    **nor** (w7, w5, w6);  
    **nor** (w8, C, D\_bar);  
    **and** (F, w7\_bar, w8\_bar);  
**endmodule**

3.32

Note: It is assumed that a complemented input is generated by another circuit that is not part of the circuit that is to be described.

- (a) **module** Fig\_3\_22a\_CA (F, A, B, C, C\_bar, D);  
    **output** F;  
    **input** A, B, C, C\_bar, D;  
    **wire** w1, w2, w3, w4;  
    **assign** w1 = C & D;  
    **assign** w2 = w1 | B;  
    **assign** w3 = w2 & A;  
    **assign** w4 = B & C\_bar;  
    **assign** F = w3 | w4;  
**endmodule**
- (b) **module** Fig\_3\_22b\_CA (F, A, B, C, C\_bar, D);  
    **output** F;  
    **input** A, B, C, C\_bar, D;  
    **wire** w1, w2, w3, w4;  
    **assign** w1\_bar = ~w1;  
    **assign** B\_bar = ~B;  
    **assign** w3\_bar = ~w3;  
    **assign** w4\_bar = ~w4;  
    **assign** w1 = ~(C & D);  
    **assign** w2 = w1\_bar | B\_bar;  
    **assign** w3 = ~(w2 & A);  
    **assign** w4 = ~(B & C\_bar);  
    **assign** F = w3\_bar | w4\_bar;  
**endmodule**
- (c) **module** Fig\_3\_23a\_CA (F, A, A\_bar, B, B\_bar, C, D\_bar);  
    **output** F;  
    **input** A, A\_bar, B, B\_bar, C, D\_bar;  
    **wire** w1, w2, w3, w4;  
    **assign** w1 = A & B\_bar;  
    **assign** w2 = A\_bar & B;  
    **assign** w3 = w1 | w2;  
    **assign** w4 = C | D\_bar;  
    **assign** F = w3 | w4;  
**endmodule**
- (d) **module** Fig\_3\_23b\_CA (F, A, A\_bar, B, B\_bar, C\_bar, D);  
    **output** F;  
    **input** A, A\_bar, B, B\_bar, C\_bar, D;  
    **wire** w1, w2, w3, w4;  
    **assign** w1 = ~(A & B\_bar);  
    **assign** w2 = ~(A\_bar & B);  
    **assign** w1\_bar = ~w1;  
    **assign** w2\_bar = ~w2;  
    **assign** w3 = w1\_bar | w2\_bar;  
    **assign** w4, C | D\_bar;  
    **assign** w5 = ~C\_bar;  
    **assign** w6 = ~D;  
    **assign** F\_bar = ~(w5 & w6);  
    **assign** F = ~F\_bar;  
**endmodule**



```
(e) module Fig_3_26_CA (F, A, B, C, D, E_bar);
    output F;
    input A, B, C, D, E_bar;
    wire w1, w2, w1_bar, w2_bar, w3_bar;
    not w1_bar = ~w1;
    not w2_bar = ~w2;
    not w3_bar = ~E_bar;
    nor w1 = (A | B);
    nor w2 = (C | D);
    nand F = ~( w1_bar & w2_bar & w3_bar);
endmodule

(f) module Fig_3_27_CA (F, A, A_bar, B, B_bar, C, D_bar);
    output F;
    input A, A_bar, B, B_bar, C, D_bar;
    wire w1, w2, w3, w4, w5, w6, w7, w8, w7_bar, w8_bar;
    not w1 = ~A_bar;
    not w2 = ~B_bar;
    not w3 = ~A;
    not w4 = ~B_bar;
    not w7_bar = ~w7;
    not w8_bar = ~w8;
    assign w5 = w1 & w2;
    assign w6 = w3 & w4;
    assign w7 = ~(w5 | w6);
    assign w8 = ~(C | D_bar);
    assign F = w7_bar & w8_bar;
endmodule
```

3.32 (a)

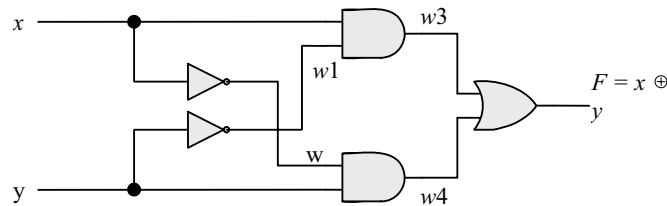

Initially, with  $xy = 00$ ,  $w1 = w2 = 1$ ,  $w3 = w4 = 0$  and  $F = 0$ .  $w1$  should change to 0 4ns after  $xy$  changes to 01.  $w4$  should change to 1 8 ns after  $xy$  changes to 01.  $F$  should change from 0 to 1 10 ns after  $w4$  changes from 0 to 1, i.e., 18 ns after  $xy$  changes from 00 to 01.

(b)

```
`timescale 1ns/1ps

module Prob_3_33 (output F, input x, y);
    wire w1, w2, w3, w4;

    and #8 (w3, x, w1);
    not #4 (w1, x);
    and #8 (w4, y, w1);
    not #4 (w2, y);
    or #10 (F, w3, w4);

endmodule

module t_Prob_3_33 ();
    reg x, y;
    wire F;
```

```
Prob_3_33 M0 (F, x, y);
```

```
initial #200 $finish;
initial fork
x = 0;
y = 0;
#20 y = 1;
join
endmodule
```

(c) To simulate the circuit, it is assumed that the inputs  $xy = 00$  have been applied sufficiently long for the circuit to be stable before  $xy = 01$  is applied. The testbench sets  $xy = 00$  at  $t = 0$  ns, and  $xy = 1$  at  $t = 10$  ns. The simulator assumes that  $xy = 00$  has been applied long enough for the circuit to be in a stable state at  $t = 0$  ns, and shows  $F = 0$  as the value of the output at  $t = 0$ . The waveforms show the response to  $xy = 01$  applied at  $t = 10$  ns.

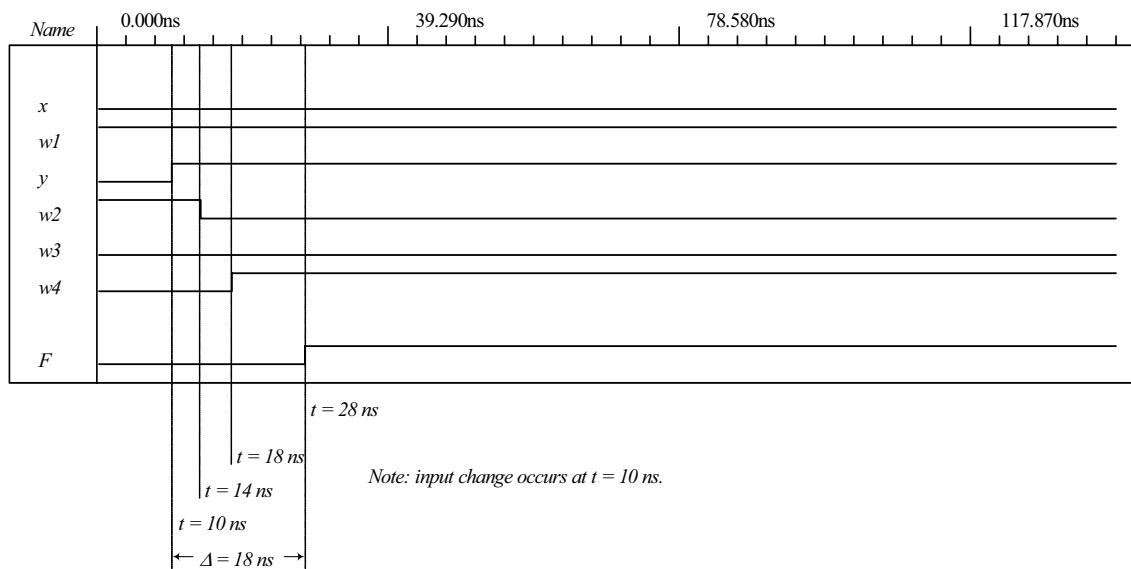

3.34

```
module Prob_3_34 (Out_1, Out_2, Out_3, A, B, C, D);
output Out_1, Out_2, Out_3;
input A, B, C, D;
wire A_bar, B_bar, C_bar, D_bar;
assign A_bar = ~A;
assign B_bar = ~B;
assign C_bar = ~C;
assign D_bar = ~D;
assign Out_1 = ~( (C | B) & (A_bar | D) & B );
assign Out_2 = ((C * B_bar) | (A & B & C) | (C_bar & B) ) & (A | D_bar);
assign Out_3 = C & ( (A & D) | B ) | (C & A_bar);
endmodule
```

3.35

```
module Exmpl-3(A, B, C, D, F) // Line 1
inputs A, B, C, Output D, F, // Line 2
output B // Line 3
and g1(A, B, B); // Line 4
not (D, B, A), // Line 5
OR (F, B; C); // Line 6
```

**endofmodule;** // Line 7

Line 1: Dash not allowed, use underscore: Exmpl\_3. Terminate line with semicolon (;).

Line 2: **inputs** should be **input** (no s at the end). Change last comma (,) to semicolon (;). *Output* is declared but does not appear in the port list, and should be followed by a comma if it is intended to be in the list of inputs. If *Output* is a misspelling of **output** and is to declare output ports, *C* should be followed by a semicolon (;) and *F* should be followed by a semicolon (;).

Line 3: *B* cannot be declared as input (Line 2) and output (Line 3). Terminate the line with a semicolon (;).

Line 4: *A* cannot be an output of the primitive if it is an input to the module

Line 5: Too many entries for the not gate (only two allowed).

Line 6: OR must be in lowercase: change to “or”.

Line 7: **endmodule** is misspelled. Remove semicolon (no semicolon after endmodule).

3.36

(a)

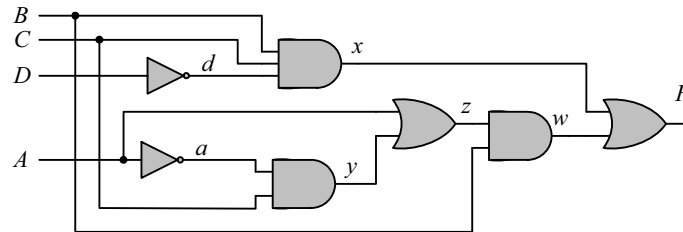

(b)

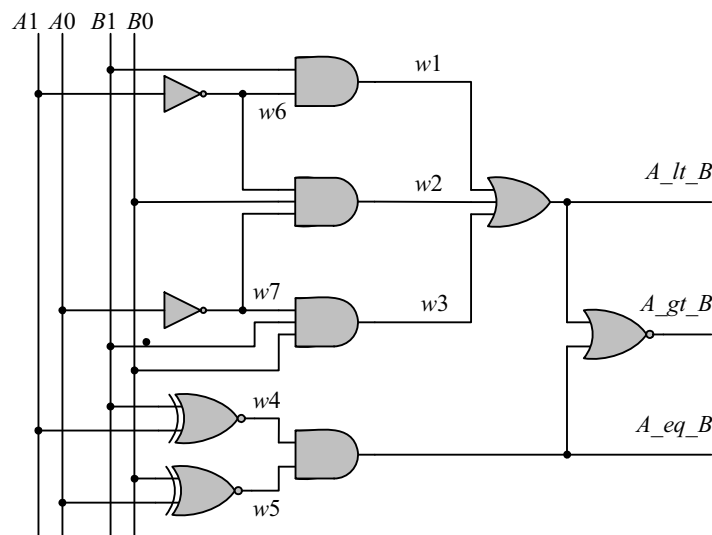

(c)

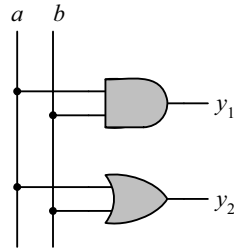

3.37

```

UDP_Majority_4 (y, a, b, c, d);
  output y;
  input a, b, c, d;
  table
  // a b c d : y
    0 0 0 0 : 0;
    0 0 0 1 : 0;
    0 0 1 0 : 0;
    0 0 1 1 : 0;
    0 1 0 0 : 0;
    0 1 0 1 : 0;
    0 1 1 0 : 0;
    0 1 1 1 : 1;

    1 0 0 0 : 0;
    1 0 0 1 : 0;
    1 0 1 0 : 0;
    1 0 1 1 : 0;
    1 1 0 0 : 0;
    1 1 0 1 : 0;
    1 1 1 0 : 1;
    1 1 1 1 : 1;
  endtable
endprimitive
  
```

3.38

```

module t_Circuit_with_UDP_02467;
  wire E, F;
  reg A, B, C, D;
  Circuit_with_UDP_02467 m0 (E, F, A, B, C, D);

  initial #100 $finish;
  initial fork
    A = 0; B = 0; C = 0; D = 0;
    #40 A = 1;
    #20 B = 1;
    #40 B = 0;
    #60 B = 1;
    #10 C = 1; #20 C = 0; #30 C = 1; #40 C = 0; #50 C = 1; #60 C = 0; #70 C = 1;
    #20 D = 1;
  join
endmodule

// Verilog model: User-defined Primitive
primitive UDP_02467 (D, A, B, C);
  output D;
  input A, B, C;
  // Truth table for D = f (A, B, C) = Σ (0, 2, 4, 6, 7);
  
```

```
table
// A B C : D // Column header comment
  0 0 0 : 1;
  0 0 1 : 0;
  0 1 0 : 1;
  0 1 1 : 0;
  1 0 0 : 1;
  1 0 1 : 0;
  1 1 0 : 1;
  1 1 1 : 1;
endtable
endprimitive
// Verilog model: Circuit instantiation of Circuit_UDP_02467
module Circuit_with_UDP_02467 (e, f, a, b, c, d);
  output e, f;
  input a, b, c, d;

  UDP_02467 M0 (e, a, b, c);
  and (f, e, d); //Option gate instance name omitted
endmodule
```

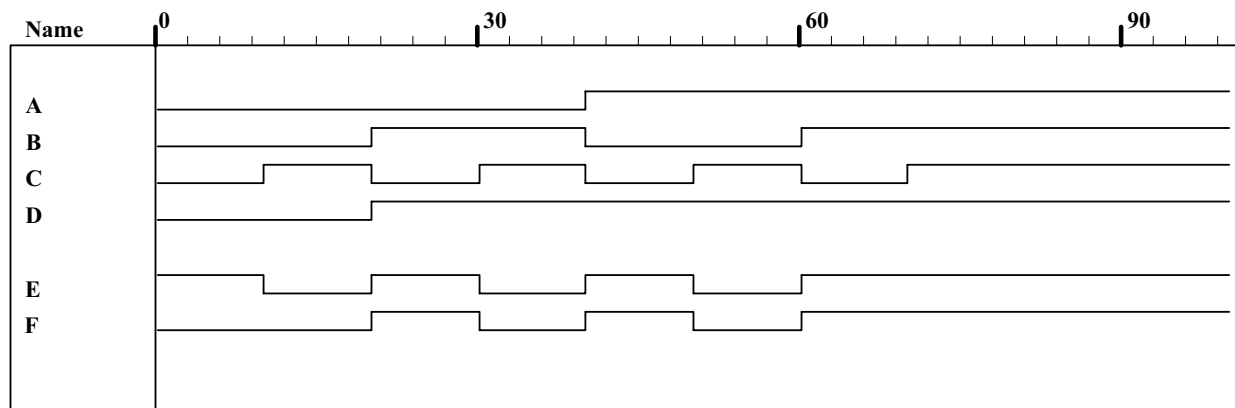

## CHAPTER 4

4.1 (a)  $T_1 = B'C, T_2 = A'B, T_3 = A + T_1 = A + B'C,$   
 $T_4 = D \oplus T_2 = D \oplus (A'B) = A'BD' + D(A + B) = A'BD' + AD + B'D$   
 $F_1 = T_3 + T_4 = A + B'C + A'BD' + AD + B'D$   
 With  $A + AD = A$  and  $A + A'BD' = A + BD'$ :  
 $F_1 = A + B'C + BD' + B'D$   
 Alternative cover:  $F_1 = A + CD' + BD' + B'D$

$F_2 = T_2 + D = A'B + D$

ABCD	$T_1$	$T_2$	$T_3$	$T_4$	$F_1$	$F_2$
0000	0	0	0	0	0	0
0001	0	0	0	1	1	1
0010	1	0	1	0	1	0
0011	1	0	1	1	1	1
0100	0	1	0	1	1	1
0101	0	1	0	0	0	1
0110	0	1	0	1	1	1
0111	0	1	0	0	0	1
1000	0	0	1	0	1	0
1001	0	0	1	1	1	1
1010	1	0	1	0	1	0
1011	1	0	1	1	1	1
1100	0	0	1	0	1	0
1101	0	0	1	1	1	1
1110	0	0	1	0	1	0
1111	0	0	1	1	1	1

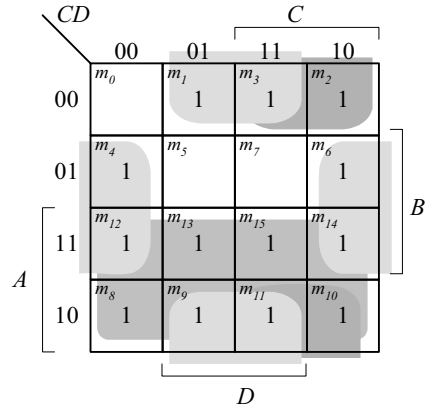

$F_1 = A + B'C + B'D + BD'$

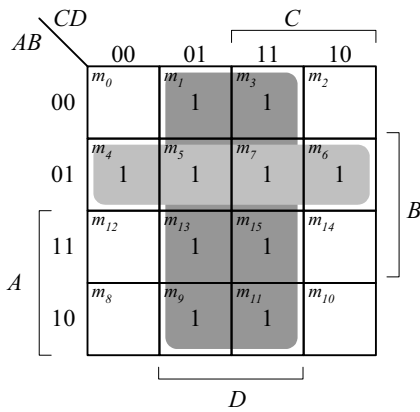

$F_2 = A'B + D$

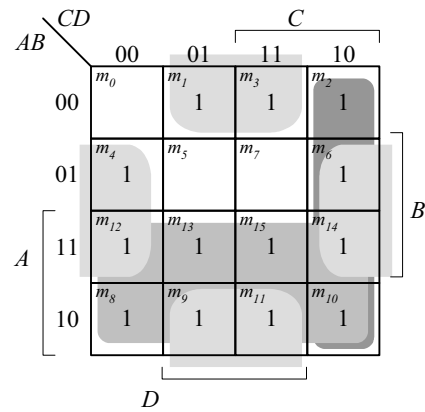

$F_1 = A + CD' + B'D + BD'$

4.2

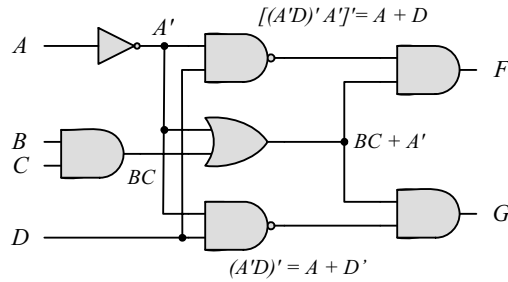

$$F = (A + D)(A' + BC) = A'D + ABC + BCD + A'D + ABC$$

$$F = (A + D')(A' + BC) = A'D' + ABC + BCD' = A'D' + ABC$$

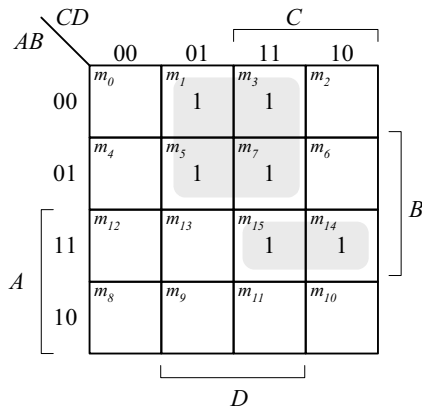

$$F = A'D + ABC + BCD = A'D + ABC$$

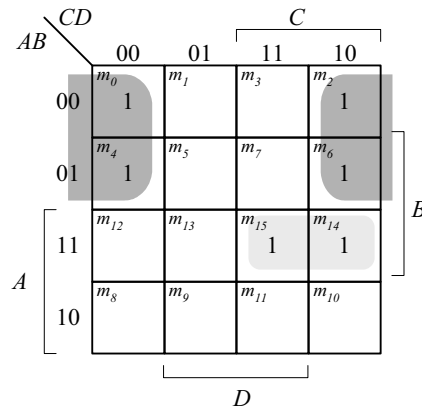

$$G = A'D' + ABC + BCD' = A'D' + ABC$$

4.3 (a)  $Y_i = (A_i S' + B_i S) E'$  for  $i = 0, 1, 2, 3$

(b) 1024 rows and 14 columns

4.4 (a)

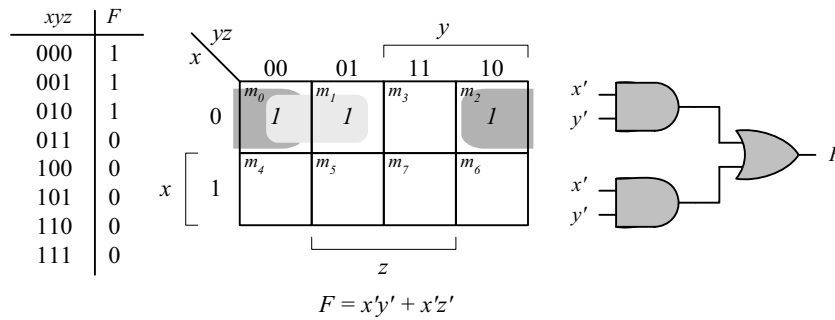

$$F = x'y' + x'z'$$

(b)

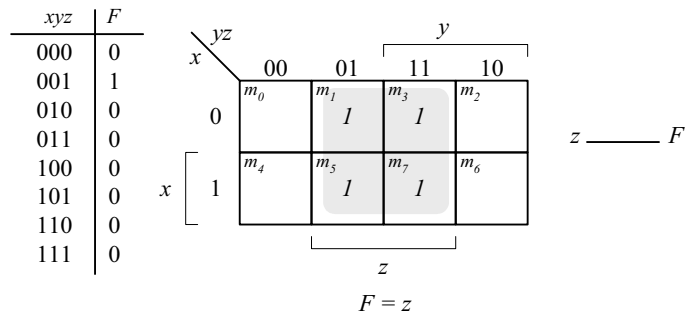

4.5

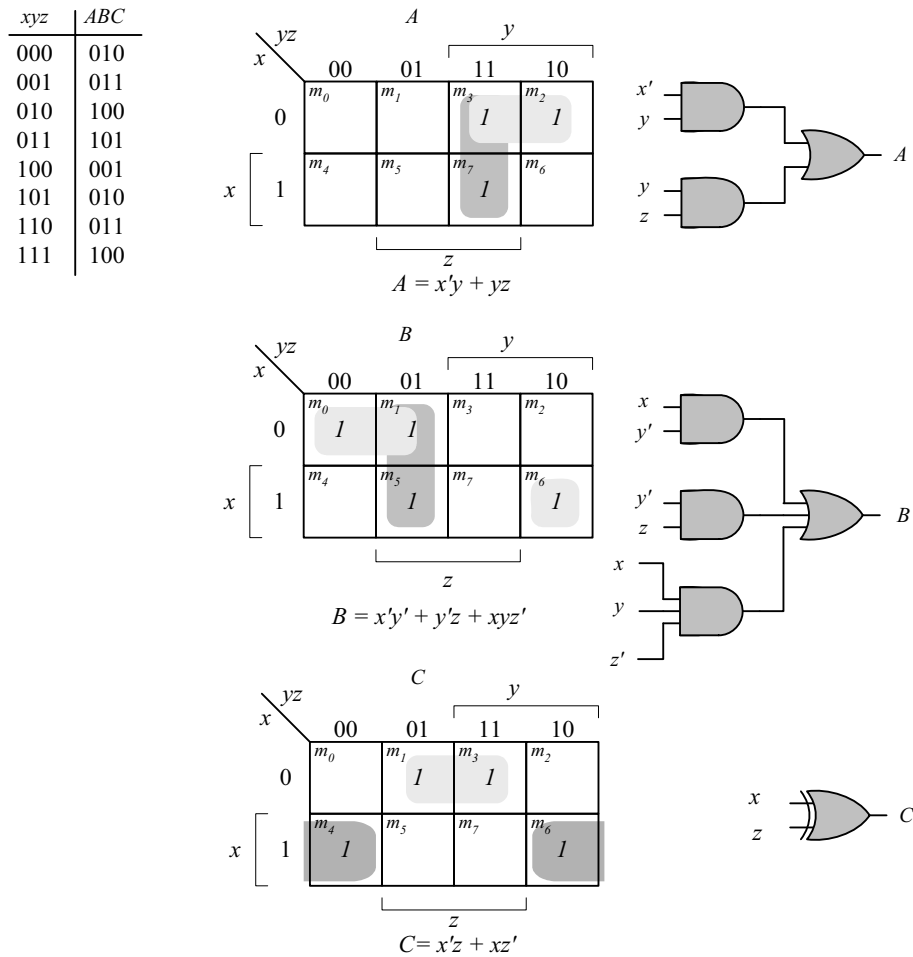

4.6

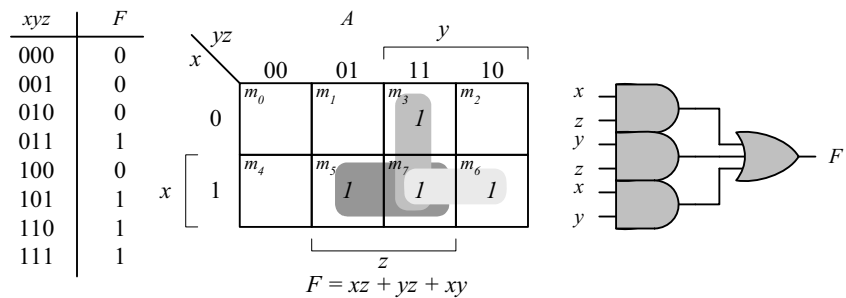



```

module Prob_4_6 (output F, input x, y, z);
  assign F = (x & z) | (y & z) | (x & y);
endmodule

```

4.7 (a)

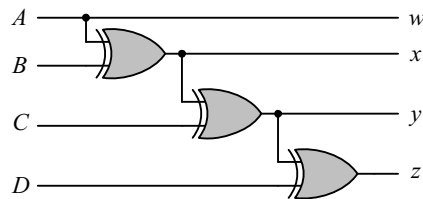
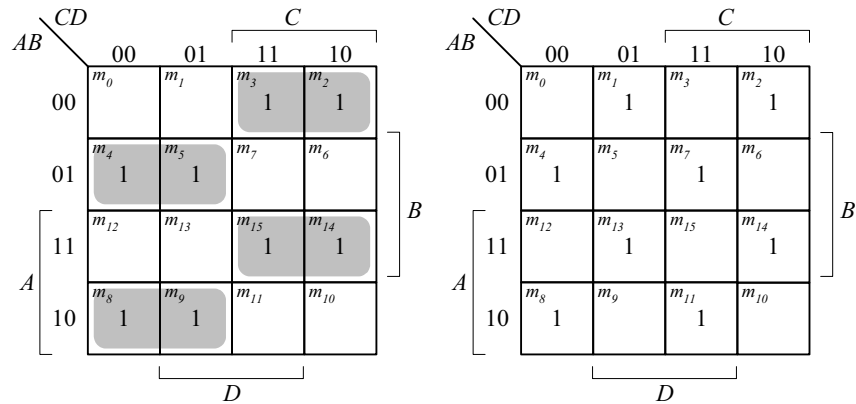
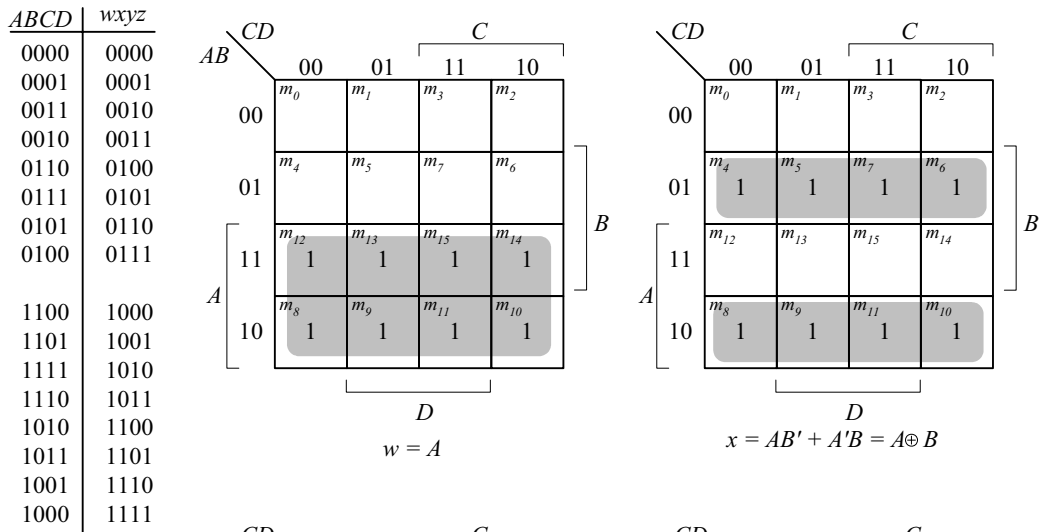

(b)

```

module Prob_4_7(output w, x, y, z, input A, B, C, D);
  always @ (A, B, C, D)
  case ({A, B, C, D})
    4'b0000: {w, x, y, z} = 4'b0000;

```

```

4'b0001: {w, x, y, z} = 4'b1111;
4'b0010: {w, x, y, z} = 4'b1110;
4'b0011: {w, x, y, z} = 4'b1101;
4'b0100: {w, x, y, z} = 4'b1100;
4'b0101: {w, x, y, z} = 4'b1011;
4'b0110: {w, x, y, z} = 4'b1010;
4'b0111: {w, x, y, z} = 4'b1001;

4'b1000: {w, x, y, z} = 4'b1000;
4'b1001: {w, x, y, z} = 4'b0111;
4'b1010: {w, x, y, z} = 4'b0110;
4'b1011: {w, x, y, z} = 4'b0101;
4'b1100: {w, x, y, z} = 4'b0100;
4'b1101: {w, x, y, z} = 4'b0011;
4'b1110: {w, x, y, z} = 4'b0010;
4'b1111: {w, x, y, z} = 4'b0001;

endcase
endmodule

```

Alternative model:

```

module Prob_4_7(output w, x, y, z, input A, B, C, D);
assign w = A;
assign x = A ^ B;
assign y = x ^ C;
assign z = y ^ D;
endmodule

```

4.8

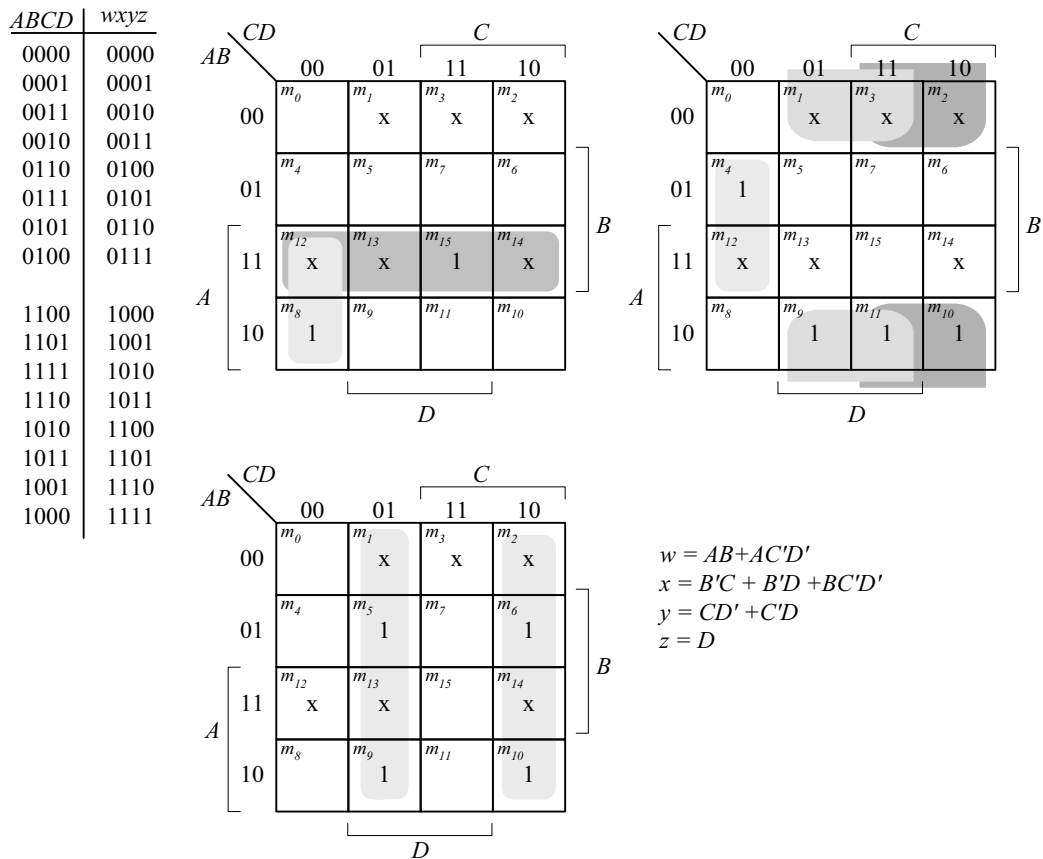

Alternative model:

```

module Prob_4_8(output w, x, y, z, input A, B, C, D);
assign w = (A&B) | (A & (~C)) & (~D) ;
assign x = (~B) & C | ((~B) & D) | (B & (~C)) & (~D);
assign y = C ^ D;
assign z = D;
endmodule
    
```

4.9

ABCD	a	b	c	d	e	f	g
0000	1	1	1	1	1	1	0
0001	0	1	1	0	0	0	0
0010	1	1	0	1	1	0	1
0011	1	1	1	1	0	0	1
0100	0	1	1	0	0	1	1
0101	1	0	1	1	0	1	1
0110	1	0	1	1	1	1	1
0111	1	1	1	0	0	0	0
1000	1	1	1	1	1	1	1
1001	1	1	1	1	0	1	1

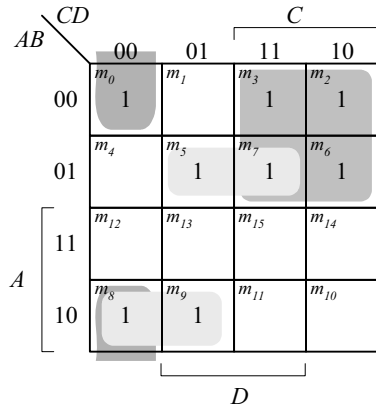

$$a = A'C + A'BD + B'C'D' + AB'C'$$

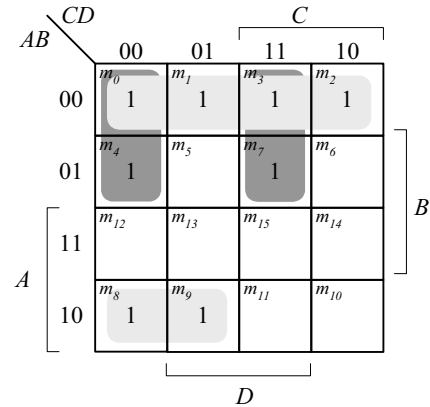

$$b = A'B' + A'C'D' + A'CD + AB'C'$$

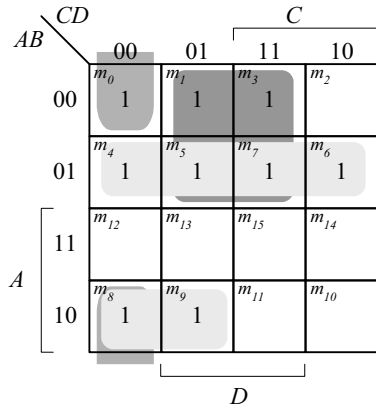

$$c = A'B + A'D + B'C'D' + AB'C'$$

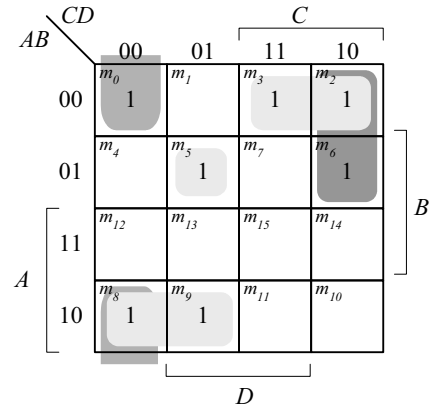

$$d = A'CD' + A'B'C + B'C'D' + AB'C' + A'BC'D'$$

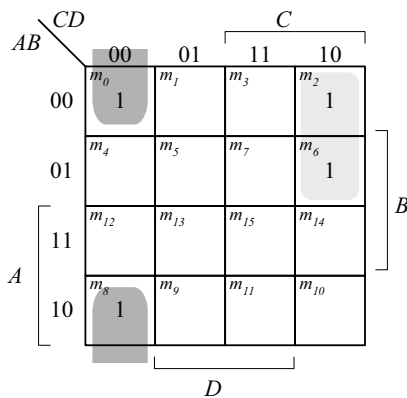

$$e = A'CD' + B'C'D'$$

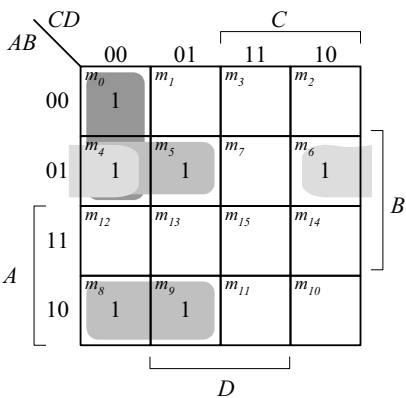

$$f = A'BC' + A'C'D' + A'BD + AB'C'$$

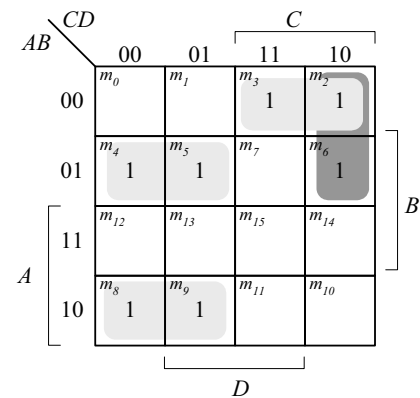

$$g = A'CD' + A'B'C + A'BC' + AB'C'$$

4.10

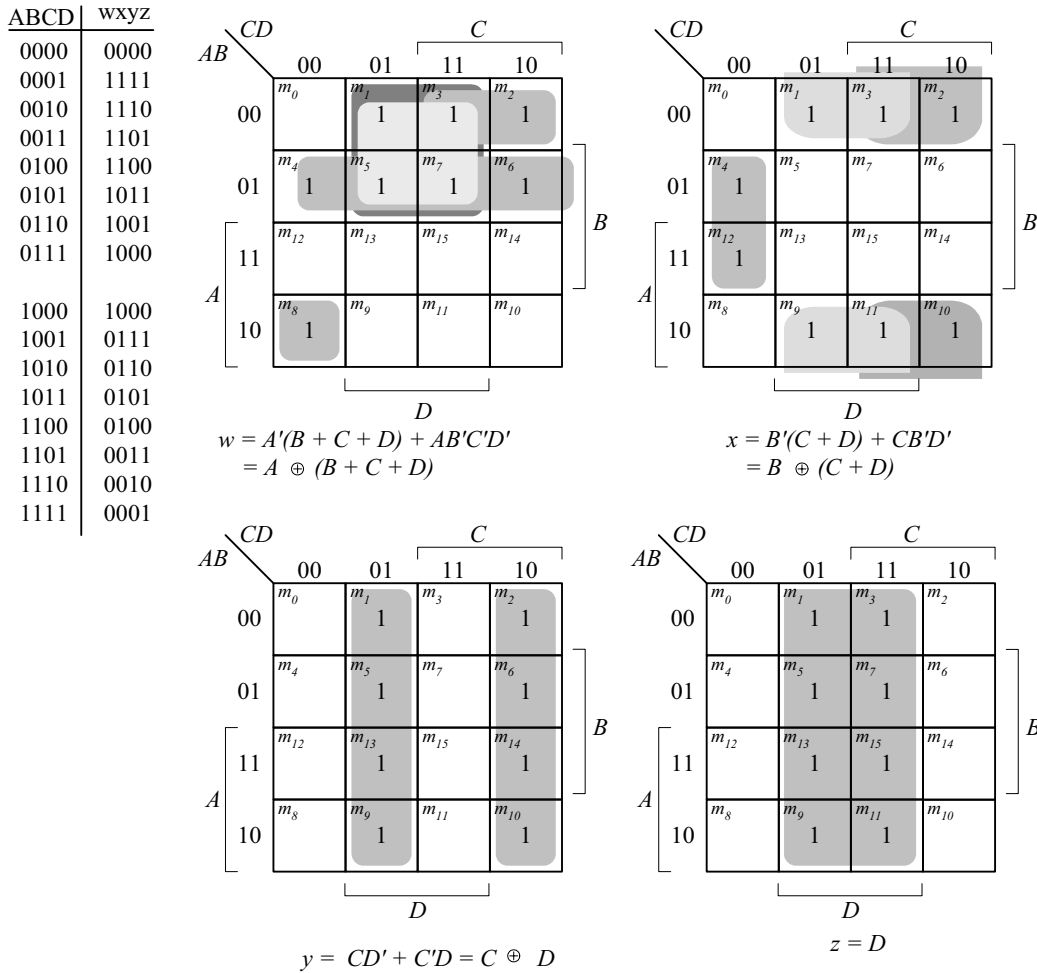

For a 5-bit 2's complementer with input E and output v:

$$v = E \oplus (A + B + C + D)$$

4.11

(a)

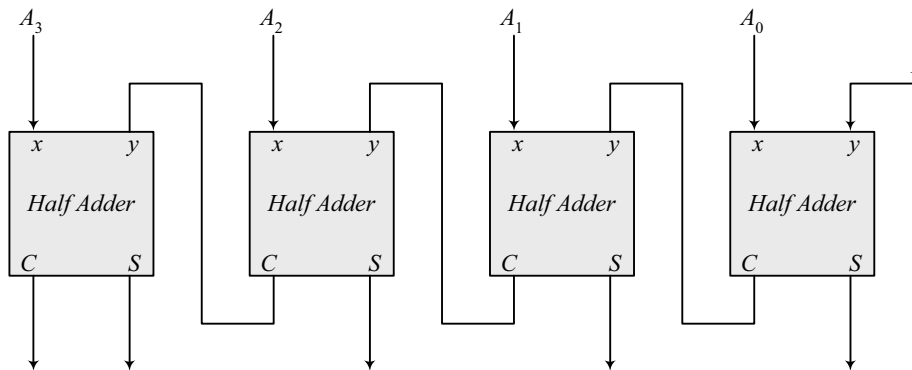

Note: 5-bit output

(b)

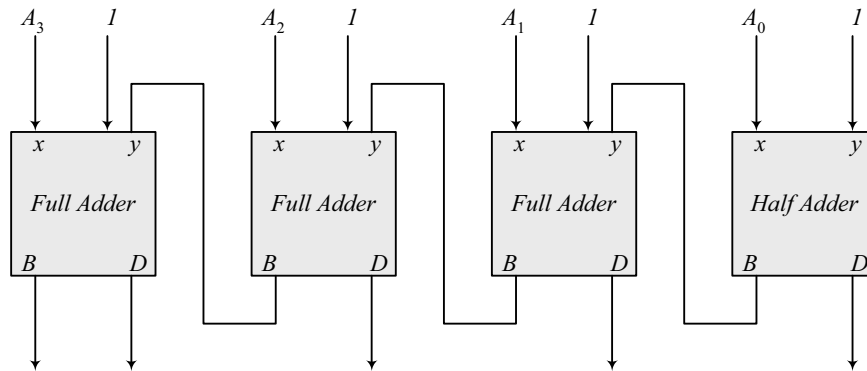

Note: To decrement the 4-bit number, add -1 to the number. In 2's complement format (add  $F_n$ ) to the number. An attempt to decrement 0 will assert the borrow bit. For waveforms, see solution to Problem 4.52.

4.12

(a)

$x$	$y$	$B$	$D$
0	0	0	0
0	1	1	1
1	0	0	1
1	1	0	0

$D = x'y + xy'$   
 $B = x'y$

(b)

$x$	$y$	$B_{in}$	$B$	$D$
0	0	0	0	0
0	0	1	1	1
0	1	0	1	1
0	1	1	1	0
1	0	0	0	1
1	0	1	0	0
1	1	0	0	0
1	1	1	1	1

$Diff = x \oplus y \oplus z$   
 $B_{out} = x'y + x'z + yz$

4.13            Sum     $C$      $V$

(a)    1101    0    1

(b)    0001    1    1

(c)    0100    1    0

(d)    1011    0    1

(e)    1111    0    0

4.14    xor    AND    OR    XOR

$$10 + 5 + 5 + 10 = 30 \text{ ns}$$

**4.15**  $C_4 = G_3 + P_3C_3 = G_3 + P_3(G_2 + P_2G_1 + P_2P_1G_0 + P_2P_1P_0C_0)$   
 $= G_3 + P_3G_2 + P_3P_2G_1 + P_3P_2P_1G_0 + P_3P_2P_1P_0C_0$

**4.16 (a)**

$$\begin{aligned} (C_i'G_i + p_i)' &= (C_i + G_i)P_i = G_iP_i + P_iC_i \\ &= A_iB_i(A_i + B_i) + P_iC_i \\ &= A_iB_i + P_iC_i = G_i + P_iC_i \\ &= A_iB_i + (A_i + B_i)C_i = A_iB_i + A_iC_i + B_iC_i = C_{i+1} \\ (P_iG_i) \oplus C_i &= (A_i + B_i)(A_iB_i)' \oplus C_i = (A_i + B_i)(A_i' + B_i') \oplus C_i \\ &= (A_i'B_i + A_iB_i') \oplus C_i = A_i \oplus B_i \oplus C_i = S_i \end{aligned}$$

**(b)**

Output of NOR gate =  $(A_0 + B_0)' = P'_0$   
 Output of NAND gate =  $(A_0B_0)' = G'_0$   
 $S_1 = (P_0G'_0) \oplus C_0$   
 $C_1 = (C'_0G'_0 + P'_0)'$  as defined in part (a)

**4.17 (a)**

$$\begin{aligned} (C_i'G_i + P_i)' &= (C_i + G_i)P_i = G_iP_i + P_iC_i = A_iB_i(A_i + B_i) + P_iC_i \\ &= A_iB_i + P_iC_i = G_i + P_iC_i \\ &= A_iB_i + (A_i + B_i)C_i = A_iB_i + A_iC_i + B_iC_i = C_{i+1} \end{aligned}$$

$$\begin{aligned} (P_iG_i) \oplus C_i &= (A_i + B_i)(A_iB_i)' \oplus C_i = (A_i + B_i)(A_i' + B_i') \oplus C_i \\ &= (A_i'B_i + A_iB_i') \oplus C_i = A_i \oplus B_i \oplus C_i = S_i \end{aligned}$$

**(b)**

Output of NOR gate =  $(A_0 + B_0)' = P'_0$   
 Output of NAND gate =  $(A_0B_0)' = G'_0$

$S_0 = (P_0G'_0) \oplus C_0$   
 $C_1 = (C'_0G'_0 + P'_0)'$  as defined in part (a)

**4.18**

Inputs <i>ABCD</i>	Outputs <i>wxyz</i>	
0000	1001	$d(A, b, c, d) = \Sigma(10, 11, 12, 13, 14, 15)$
0001	1000	
0010	0111	
0011	0110	
0100	0101	
0101	0100	
0110	0011	
0111	0010	
1000	0001	
1001	0000	

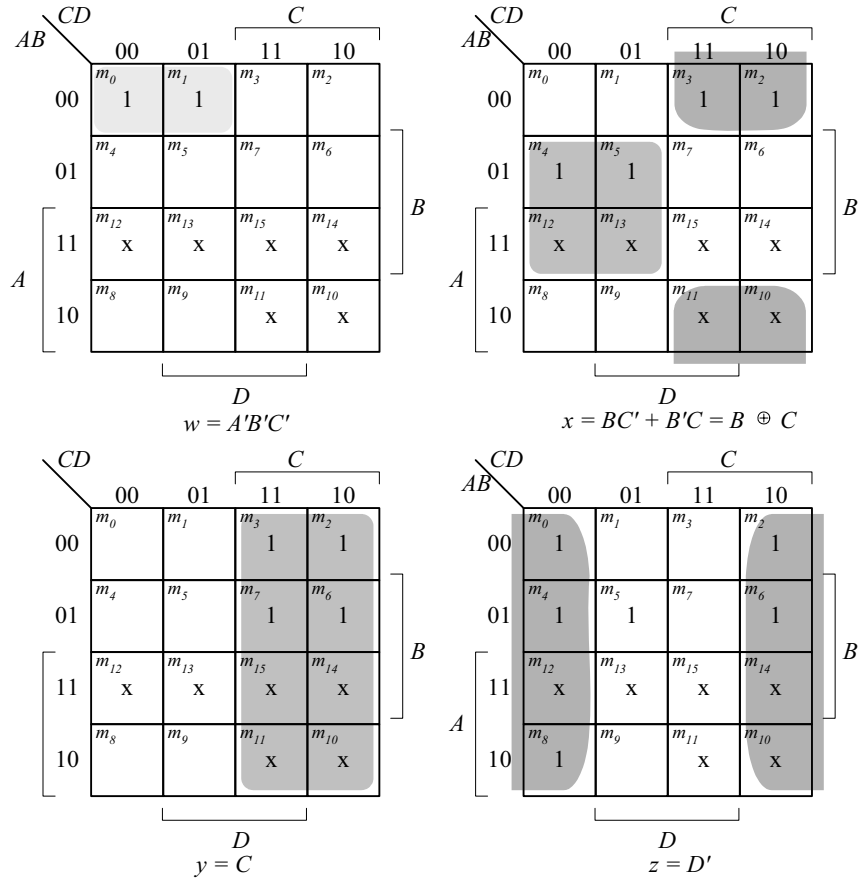

4.19

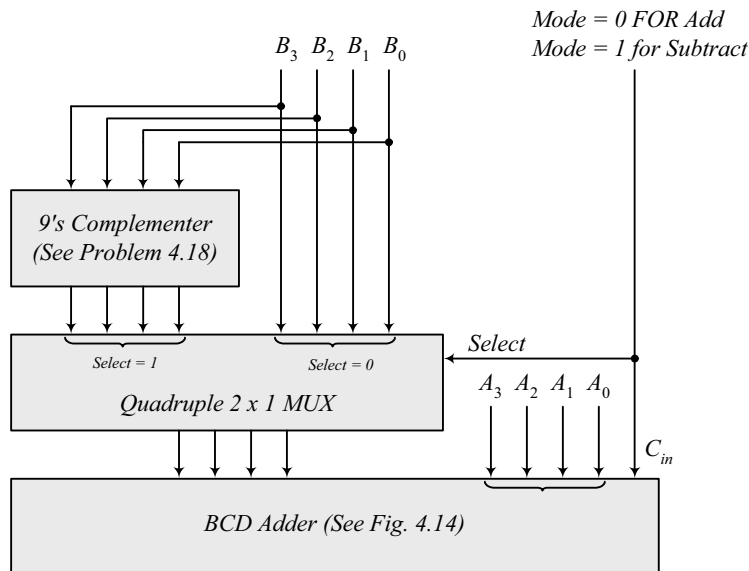

4.20 Combine the following circuit with the 4-bit binary multiplier circuit of Fig. 4.16.

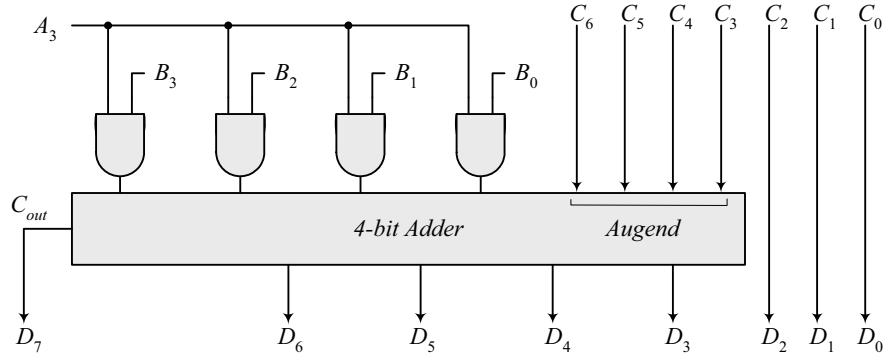

4.21

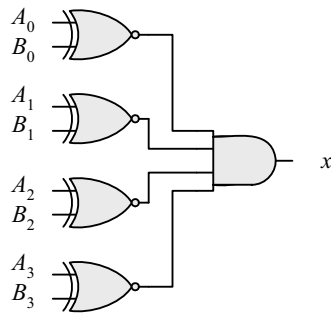

$$x = (A_0 \oplus B_0)'(A_1 \oplus B_1)'(A_2 \oplus B_2)'(A_3 \oplus B_3)'$$

4.22

XS-3 <i>ABCD</i>	Binary <i>wxyz</i>
0011	0000
0100	0001
0101	0010
0110	0011
0111	0100
1000	0101
1001	0110
1010	0111
1011	1000
1100	1001



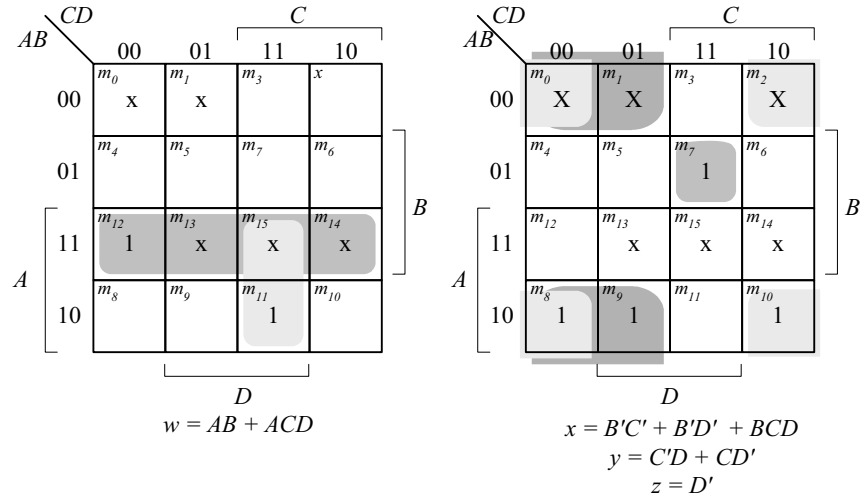

4.23

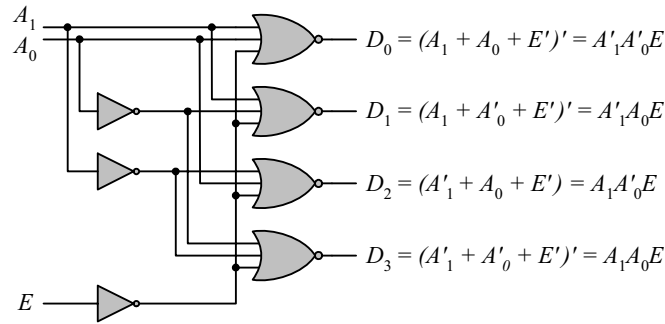

4.24

Inputs:  $A, B, C, D$

$D_0 = A'B'C'D'$   
 $D_1 = A'B'C'D$   
 $D_2 = B'CD'$   
 $D_3 = B'CD$   
 $D_4 = BC'D'$

Outputs:  $D_0, D_1, \dots, D_9$   
 $D_5 = BC'D$   
 $D_6 = BCD'$   
 $D_7 = BCD$   
 $D_8 = AD'$   
 $D_9 = AD$

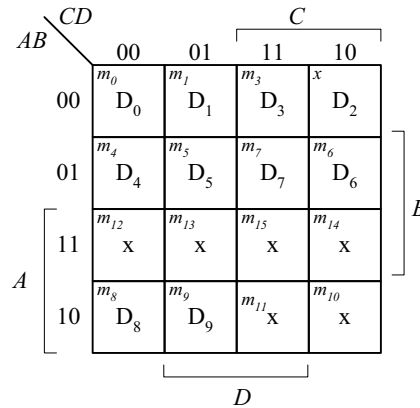

4.25

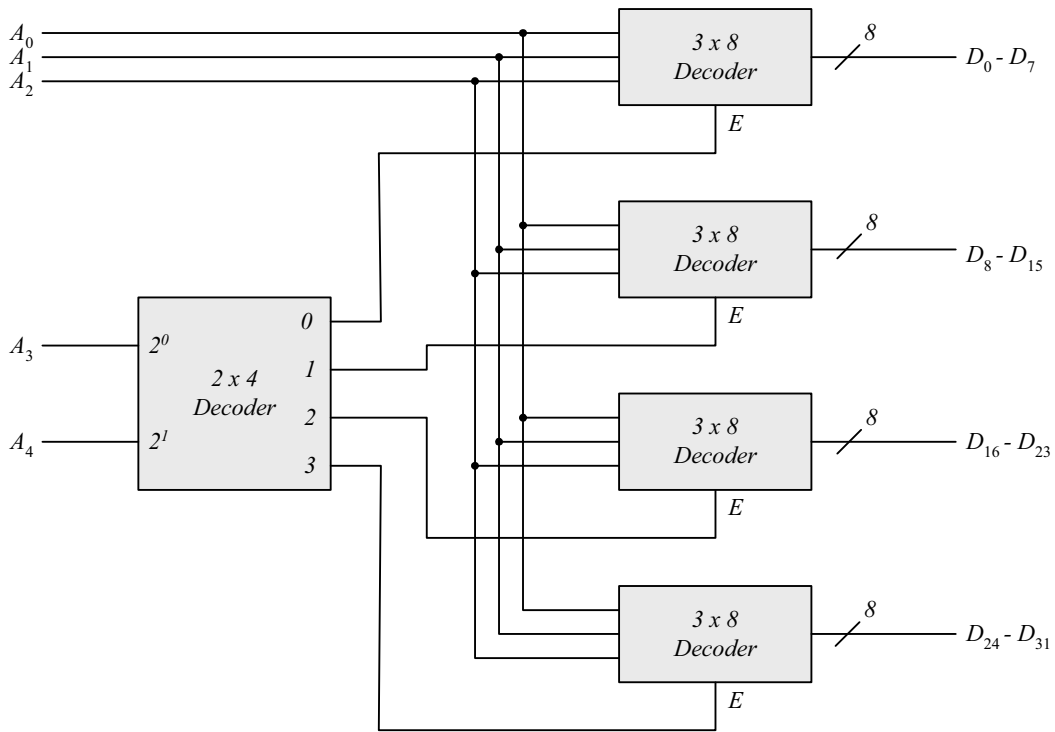

4.26

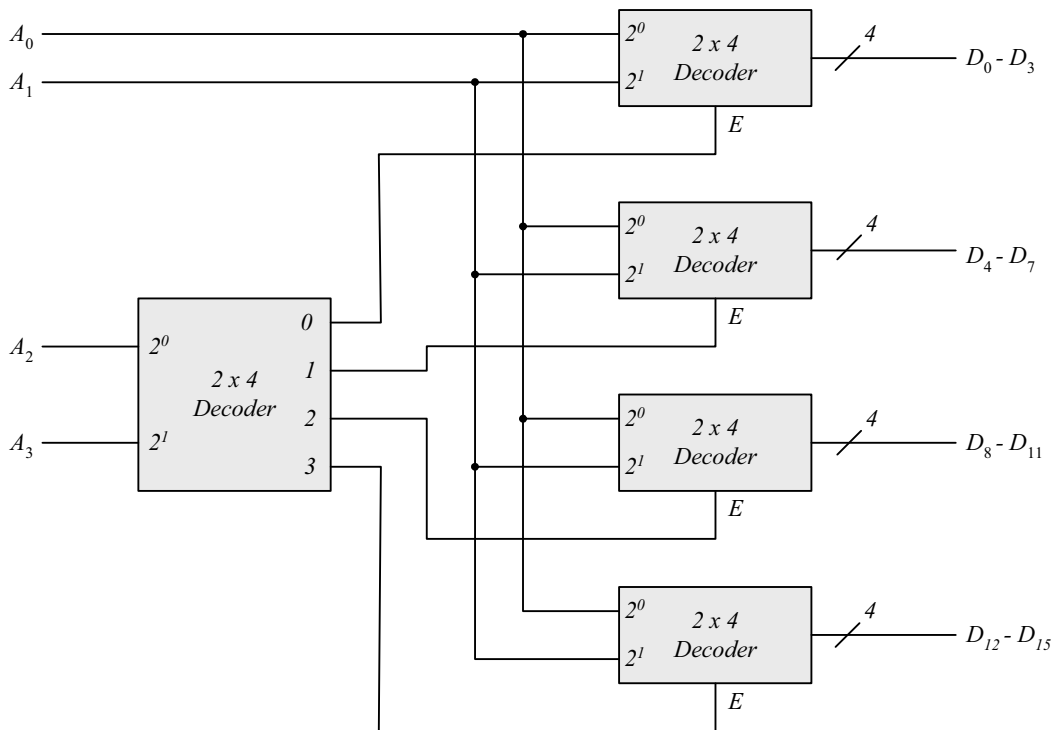

4.27

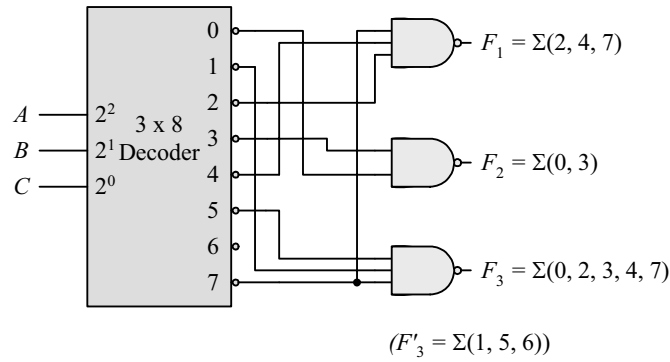

4.28 (a)

$$F_1 = x(y + y')z = x'y'z' = \Sigma(0, 5, 7)$$

$$F_2 = xy'z' + x'y + x'y(z + z') = \Sigma(2, 3, 4)$$

$$F_3 = x'y'z + xy(z + z') = \Sigma(1, 6, 7)$$

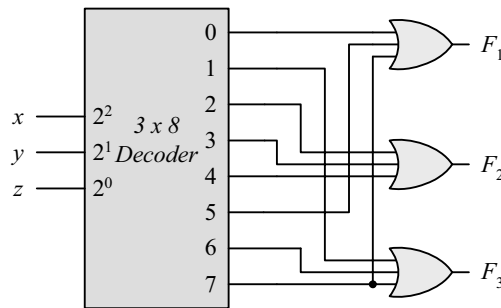

(b)

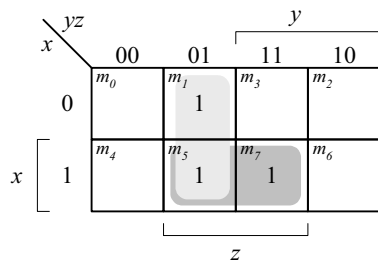

$$F_1 = y'z + xz = \Sigma(1, 5, 7)$$

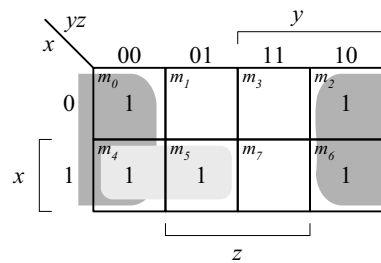

$$F_2 = y'z' + xy' + yz' = \Sigma(0, 2, 4, 5, 6)$$

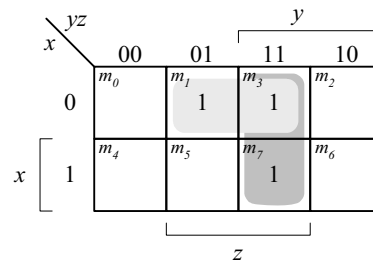
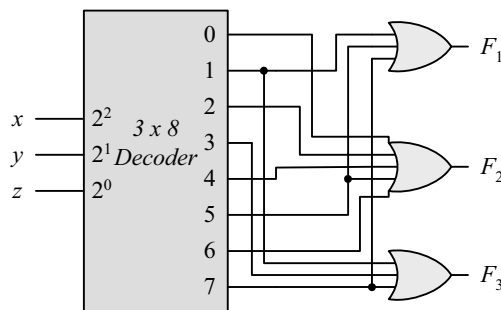

$$F_3 = x'z + yz = \Sigma(1, 3, 7)$$

4.29

Inputs				Outputs		
$D_3$	$D_2$	$D_1$	$D_0$	$X$	$Y$	$Z$
0	0	0	0	x	x	0
x	x	x	1	0	0	1
x	x	1	0	0	1	1
x	1	0	0	1	0	1
1	0	0	0	1	1	1

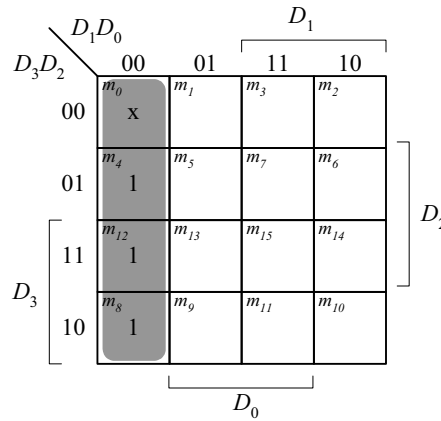

$$v = D_0 + D_1 + D_2 + D_3$$

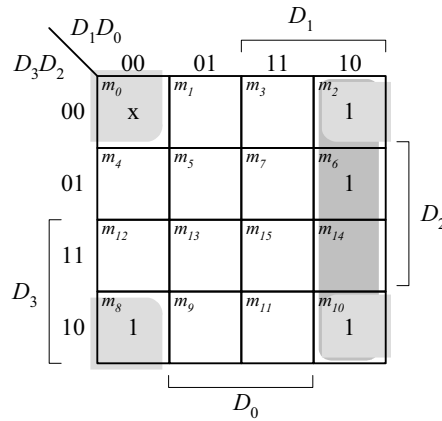
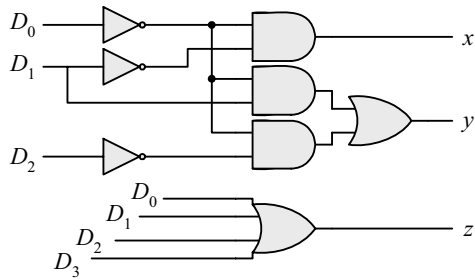

$$y = D'_0D_1 + D'_0D'_2$$

4.30

Inputs								Outputs				
$D_0$	$D_1$	$D_2$	$D_3$	$D_4$	$D_5$	$D_6$	$D_7$	$x$	$y$	$z$	$V$	
0	0	0	0	0	0	0	0	0	x	x	x	0
1	0	0	0	0	0	0	0	0	0	0	0	1
x	1	0	0	0	0	0	0	0	0	0	1	1
x	x	1	0	0	0	0	0	0	0	1	0	1
x	x	x	1	0	0	0	0	0	0	1	1	1
x	x	x	x	1	0	0	0	0	0	1	0	0
x	x	x	x	x	1	0	0	0	0	1	0	1
x	x	x	x	x	x	1	0	0	0	1	0	0
x	x	x	x	x	x	x	1	0	0	1	1	1

If  $D_2 = 1, D_6 = 1$ , all others = 0  
Output  $xyz = 100$  and  $V = 1$

4.31

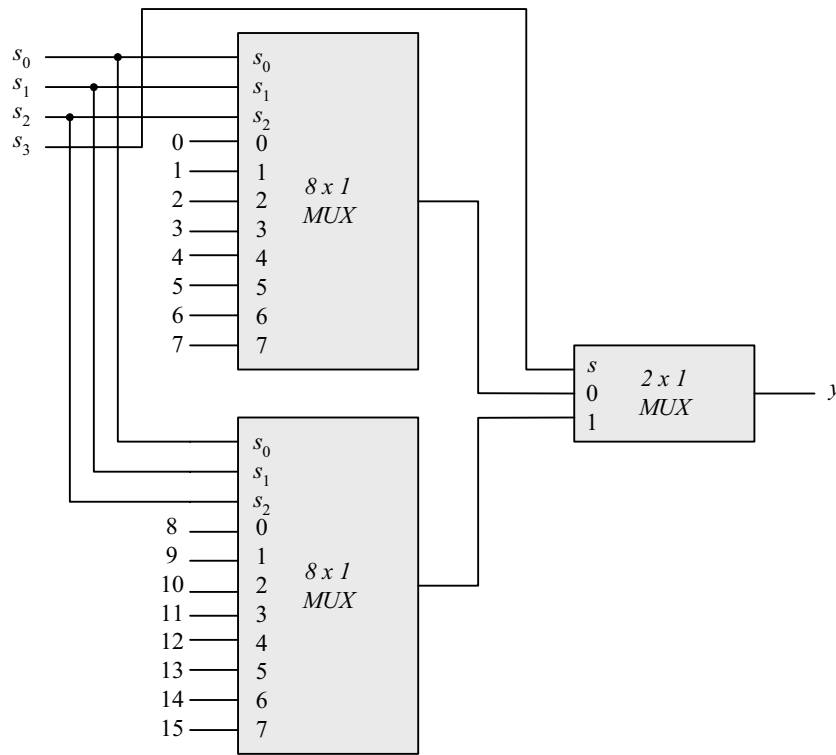

4.32

(a)  $F = \Sigma (0, 2, 5, 7, 11, 14)$

Inputs ABCD	F
0000	1 $F = D'$
0001	0
0010	1 $F = D$
0011	0
0100	0 $F = D$
0101	1 $F = D$
0110	0 $F = D$
0111	1
1000	0 $F = 0$
1001	0
1010	0 $F = 0$
1011	0
1100	0 $F = D$
1101	1
1110	1 $F = D'$
1111	0

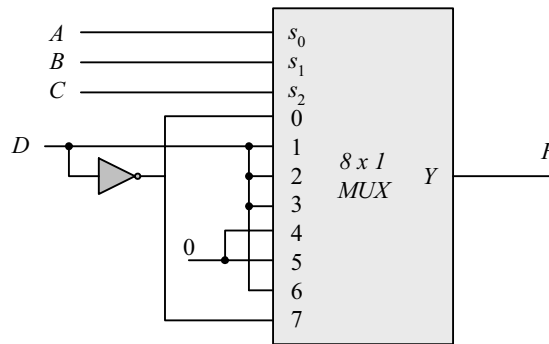

(b)  $F = \Pi(3, 8, 12) = (A' + B' + C + D)(A + B' + C' + D')(A + B + C' + D')$   
 $F' = ABC'D' + A'BCD + A'B'CD = \Sigma(12, 7, 3)$   
 $F = \Sigma(0, 1, 2, 4, 5, 6, 8, 9, 10, 11, 13, 14, 15)$

Inputs ABCD	F
0000	1 $F = 1$
0001	1
0010	1 $F = D'$
0011	0
0100	1 $F = 1$
0101	1
0110	1 $F = D'$
0111	0
1000	1 $F = 1$
1001	1
1010	1 $F = 1$
1011	1
1100	0 $F = D$
1101	1
1110	1 $F = 1$
1111	1

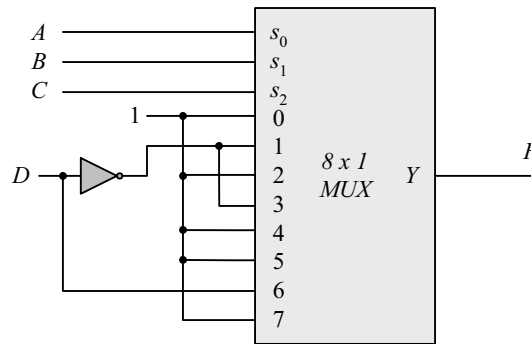

4.33

$S(x, y, z) = \Sigma(1, 2, 4, 7)$   
 $C(x, y, z) = \Sigma(3, 5, 6, 7)$

S	$I_0$	$I_1$	$I_2$	$I_3$	C	$I_0$	$I_1$	$I_2$	$I_3$
$x'$	0	1	2	3	$x'$	0	1	2	3
x	4	5	6	7	x	4	5	6	7
	x	$x'$	$x'$	x		0	$x'$	$x'$	1

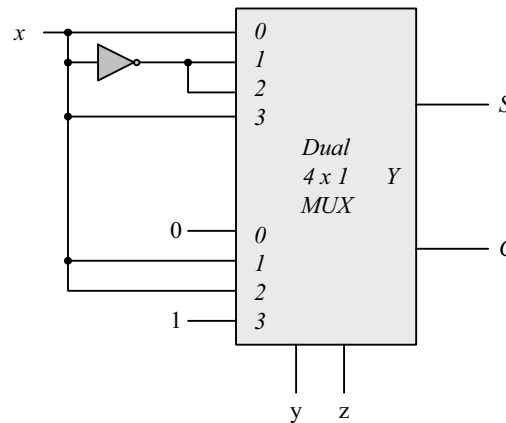

4.34 (a)

	A	B	C	D	F
$I_3 = 1$	0	1	1	0	1
	0	1	1	1	1
$I_5 = 1$	1	0	1	0	1
	1	0	1	1	1
$I_0 = D$	0	0	0	0	0
	0	0	0	1	1
$I_4 = D$	1	0	0	0	0
	1	0	0	1	1
$I_6 = D'$	1	1	0	0	1
	1	1	0	1	0

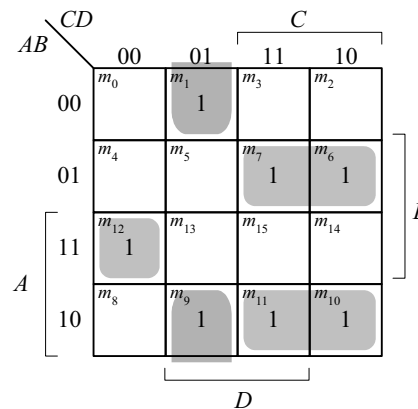

Other minterms = 0  
 since  $I_1 = I_2 = I_7 = 0$

$F(A, B, C, D) = \Sigma(1, 6, 7, 9, 10, 11, 12)$

(b)

	A	B	C	D	F
$I_1 = 0$	0	0	1	0	0
$I_2 = 0$	0	1	0	0	0
$I_3 = 1$	0	1	1	0	1
$I_7 = 1$	1	1	1	0	1
$I_4 = D$	1	0	0	0	0
$I_0 = D'$	0	0	0	0	1
$I_6 = D'$	1	1	0	0	1
	1	1	0	1	0

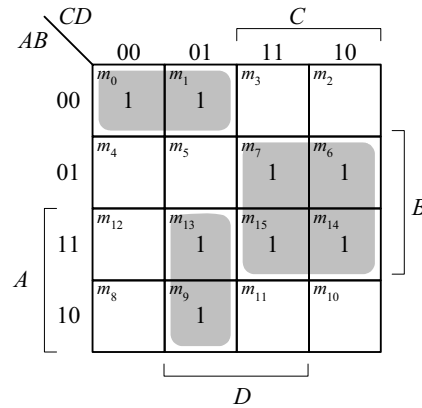

$$F(A, B, C, D) = \Sigma(0, 1, 6, 7, 9, 13, 14, 15)$$

Other minterms = 0  
since  $I_1 = I_2 = 0$

4.35 (a)

Inputs ABCD	F
0000	0
0001	1 $AB = 00$
0010	0 $F = D$
0011	1
0100	1 $AB = 01$
0101	0 $F = C'D'$
0110	0 $= (C + D)'$
0111	0
1000	0
1001	0 $AB = 10$
1010	0 $F = CD$
1011	1
1100	1 $AB = 11$
1101	1 $F = 1$
1110	1
1111	1

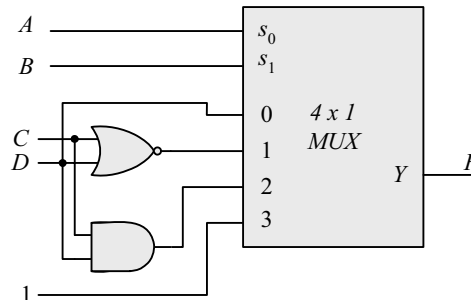

(b)

Inputs ABCD	F
0000	0
0001	1 $AB = 00$
0010	1 $F = C'D + CD'$
0011	0
0100	1 $AB = 01$
0101	0 $F = C'D' + CD$
0110	0
0111	1
1000	1
1001	1 $AB = 10$
1010	1 $F = 1$
1011	1
1100	0 $AB = 11$
1101	1 $F = D$
1110	0
1111	1

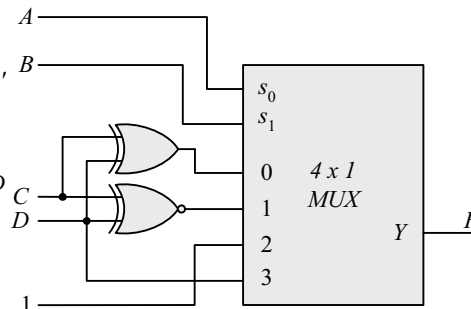

4.36

```
module priority_encoder_gates (output x, y, V, input D0, D1, D2, D3); // V2001
  wire w1, D2_not;
  not (D2_not, D2);
  or (x, D2, D3);
  or (V, D0, D1, x);
  and (w1, D2_not, D1);
  or (y, D3, w1);
endmodule
```

Note: See Problem 4.45 for testbench)

4.37

```
module Add_Sub_4_bit (
  output [3: 0] S,
  output C,
  input [3: 0] A, B,
  input M
);
  wire [3: 0] B_xor_M;
  wire C1, C2, C3, C4;
  assign C = C4; // output carry
  xor (B_xor_M[0], B[0], M);
  xor (B_xor_M[1], B[1], M);
  xor (B_xor_M[2], B[2], M);
  xor (B_xor_M[3], B[3], M);
  // Instantiate full adders
  full_adder FA0 (S[0], C1, A[0], B_xor_M[0], M);
  full_adder FA1 (S[1], C2, A[1], B_xor_M[1], C1);
  full_adder FA2 (S[2], C3, A[2], B_xor_M[2], C2);
  full_adder FA3 (S[3], C4, A[3], B_xor_M[3], C3);
endmodule
```

```
module full_adder (output S, C, input x, y, z); // See HDL Example 4.2
  wire S1, C1, C2;
  // instantiate half adders
  half_adder HA1 (S1, C1, x, y);
  half_adder HA2 (S, C2, S1, z);
  or G1 (C, C2, C1);
endmodule
```

```
module half_adder (output S, C, input x, y); // See HDL Example 4.2
  xor (S, x, y);
  and (C, x, y);
endmodule
```

```
module t_Add_Sub_4_bit ();
  wire [3: 0] S;
  wire C;
  reg [3: 0] A, B;
  reg M;

  Add_Sub_4_bit M0 (S, C, A, B, M);
```

```
  initial #100 $finish;
  initial fork
    #10 M = 0;
    #10 A = 4'hA;
    #10 B = 4'h5;
```



```
#50 M = 1;
#70 B = 4'h3;
join
endmodule
```

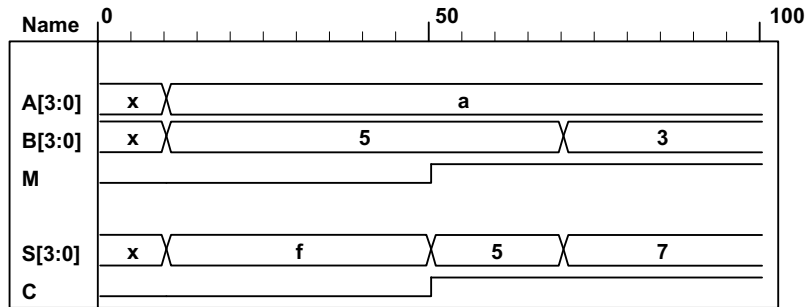

4.38

```
module quad_2x1_mux ( // V2001
input [3: 0] A, B, // 4-bit data channels
input enable_bar, select, // enable_bar is active-low)
output [3: 0] Y // 4-bit mux output
);
//assign Y = enable_bar ? 0 : (select ? B : A); // Grounds output
assign Y = enable_bar ? 4'bzzzz : (select ? B : A); // Three-state output
endmodule
```

// Note that this mux grounds the output when the mux is not active.

```
module t_quad_2x1_mux ();
reg [3: 0] A, B, C; // 4-bit data channels
reg enable_bar, select; // enable_bar is active-low)
wire [3: 0] Y; // 4-bit mux
```

```
quad_2x1_mux M0 (A, B, enable_bar, select, Y);
```

```
initial #200 $finish;
initial fork
enable_bar = 1;
select = 1;
A = 4'hA;
B = 4'h5;
#10 select = 0; // channel A
#20 enable_bar = 0;
#30 A = 4'h0;
#40 A = 4'hF;
#50 enable_bar = 1;
#60 select = 1; // channel B
#70 enable_bar = 0;
#80 B = 4'h00;
#90 B = 4'hA;
#100 B = 4'hF;
#110 enable_bar = 1;
#120 select = 0;
#130 select = 1;
#140 enable_bar = 1;
join
endmodule
```

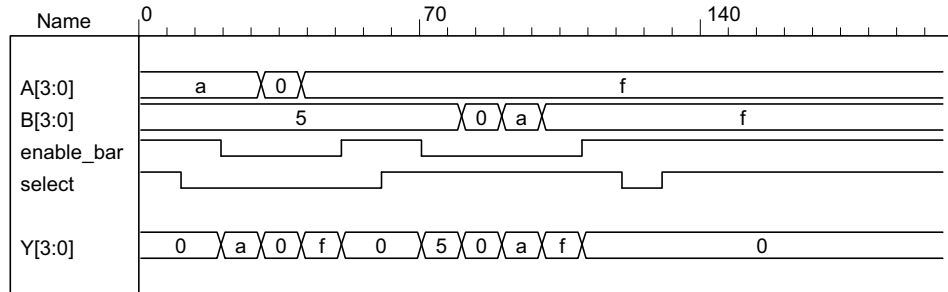

With three-state output:

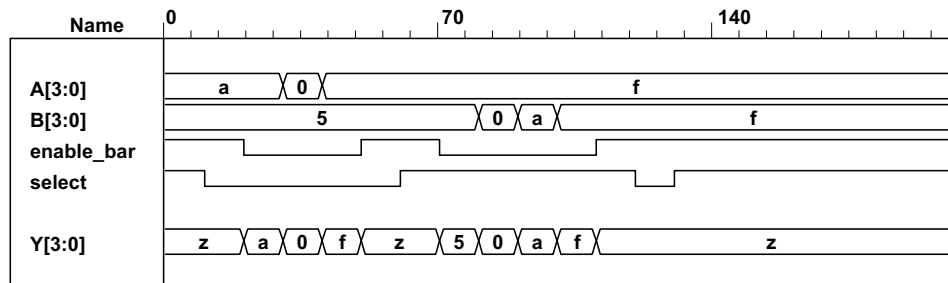

```
4.39 // Verilog 1995
module Compare (A, B, Y);
  input  [3: 0] A, B; // 4-bit data inputs.
  output [5: 0] Y; // 6-bit comparator output.
  reg [5: 0] Y; // EQ, NE, GT, LT, GE, LE

  always @ (A or B)
    if (A==B) Y = 6'b10_0011; // EQ, GE, LE
    else if (A < B) Y = 6'b01_0101; // NE, LT, LE
    else Y = 6'b01_1010; // NE, GT, GE
endmodule
```

```
// Verilog 2001, 2005

module Compare (input [3: 0] A, B, output reg [5:0] Y);
  always @ (A, B)
    if (A==B) Y = 6'b10_0011; // EQ, GE, LE
    else if (A < B) Y = 6'b01_0101; // NE, LT, LE
    else Y = 6'b01_1010; // NE, GT, GE
endmodule
```

```
4.40

module Prob_4_40 (
  output [3: 0] sum_diff, output carry_borrow,
  input [3: 0] A, B, input sel_diff
);

  assign {carry_borrow, sum_diff} = sel_diff ? A - B : A + B;
endmodule

module t_Prob_4_40;
  wire [3: 0] sum_diff;
  wire carry_borrow;
  reg [3:0] A, B;
```

```
reg sel_diff;

integer I, J, K;
Prob_4_40 M0 ( sum_diff, carry_borrow, A, B, sel_diff);
initial #4000 $finish;
initial begin
  for (I = 0; I < 2; I = I + 1) begin
    sel_diff = I;
    for (J = 0; J < 16; J = J + 1) begin
      A = J;
      for (K = 0; K < 16; K = K + 1) begin B = K; #5 ; end
    end
  end
end
endmodule
```

#### 4.41

```
module Prob_4_41 (
  output reg [3: 0] sum_diff, output reg carry_borrow,
  input [3: 0] A, B, input sel_diff
);

  always @ (A, B, sel_diff)
    {carry_borrow, sum_diff} = sel_diff ? A - B : A + B;

endmodule

module t_Prob_4_41;
  wire [3: 0] sum_diff;
  wire carry_borrow;
  reg [3:0] A, B;
  reg sel_diff;

  integer I, J, K;
  Prob_4_46 M0 ( sum_diff, carry_borrow, A, B, sel_diff);
  initial #4000 $finish;
  initial begin
    for (I = 0; I < 2; I = I + 1) begin
      sel_diff = I;
      for (J = 0; J < 16; J = J + 1) begin
        A = J;
        for (K = 0; K < 16; K = K + 1) begin B = K; #5 ; end
      end
    end
  end
end
endmodule
```

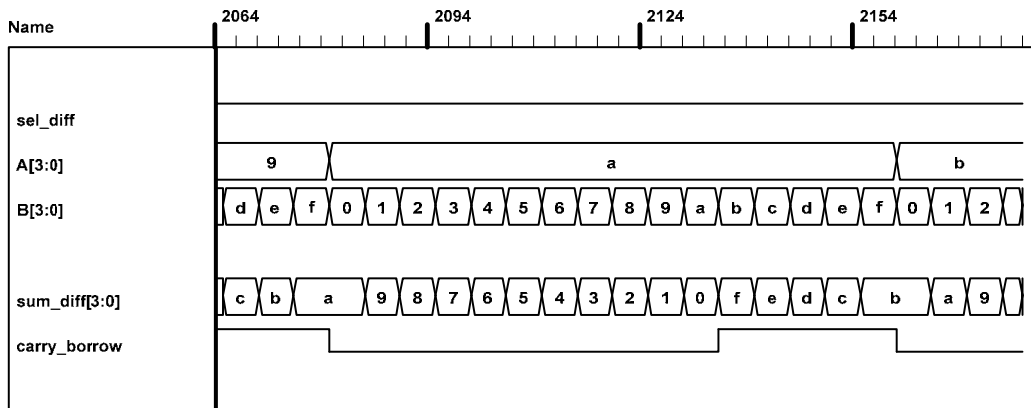
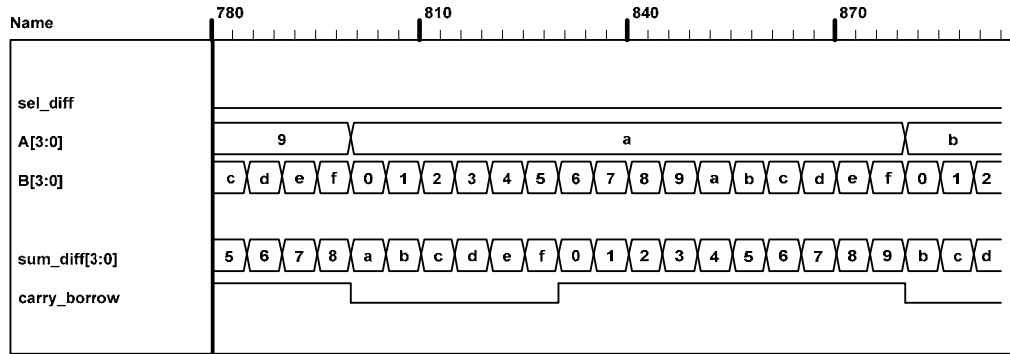

4.42

(a)

**module** Xs3\_Gates (**input** A, B, C, D, **output** w, x, y, z);

**wire** B\_bar, C\_or\_D\_bar;

**wire** CD, C\_or\_D;

**or** (C\_or\_D, C, D);

**not** (C\_or\_D\_bar, C\_or\_D);

**not** (B\_bar, B);

**and** (CD, C, D);

**not** (z, D);

**or** (y, CD, C\_or\_D\_bar);

**and** (w1, C\_or\_D\_bar, B);

**and** (w2, B\_bar, C\_or\_D);

**and** (w3, C\_or\_D, B);

**or** (x, w1, w2);

**or** (w, w3, A);

**endmodule**

(b)

**module** Xs3\_Dataflow (**input** A, B, C, D, **output** w, x, y, z);

**assign** {w, x, y, z} = {A, B, C, D} + 4'b0011;

**endmodule**

(c)

**module** Xs3\_Behavior\_95 (A, B, C, D, w, x, y, z);

**input** A, B, C, D;

**output** w, x, y, z;

**reg** w, x, y, z;

**always @** (A or B or C or D) **begin** {w, x, y, z} = {A, B, C, D} + 4'b0011; **end**

**module** Xs3\_Behavior\_01 (**input** A, B, C, D, **output reg** w, x, y, z);

```
always @ (A, B, C, D) begin {w, x, y, z} = {A, B,C, D} + 4'b0011; end
endmodule
```

```
module t_Xs3_Converters ();
reg A, B, C, D;
wire w_Gates, x_Gates, y_Gates, z_Gates;
wire w_Dataflow, x_Dataflow, y_Dataflow, z_Dataflow;
wire w_Behavior_95, x_Behavior_95, y_Behavior_95, z_Behavior_95;
wire w_Behavior_01, x_Behavior_01, y_Behavior_01, z_Behavior_01;
integer k;
wire [3: 0] BCD_value;
wire [3: 0] Xs3_Gates = {w_Gates, x_Gates, y_Gates, z_Gates};
wire [3: 0] Xs3_Dataflow = {w_Dataflow, x_Dataflow, y_Dataflow, z_Dataflow};
wire [3: 0] Xs3_Behavior_95 = {w_Behavior_95, x_Behavior_95, y_Behavior_95, z_Behavior_95};
wire [3: 0] Xs3_Behavior_01 = {w_Behavior_01, x_Behavior_01, y_Behavior_01, z_Behavior_01};

assign BCD_value = {A, B, C, D};
Xs3_Gates M0 (A, B, C, D, w_Gates, x_Gates, y_Gates, z_Gates);
Xs3_Dataflow M1 (A, B, C, D, w_Dataflow, x_Dataflow, y_Dataflow, z_Dataflow);
Xs3_Behavior_95 M2 (A, B, C, D, w_Behavior_95, x_Behavior_95, y_Behavior_95, z_Behavior_95);
Xs3_Behavior_01 M3 (A, B, C, D, w_Behavior_01, x_Behavior_01, y_Behavior_01, z_Behavior_01);

initial #200 $finish;
initial begin
    k = 0;
    repeat (10) begin {A, B, C, D} = k; #10 k = k + 1; end
end
endmodule
```

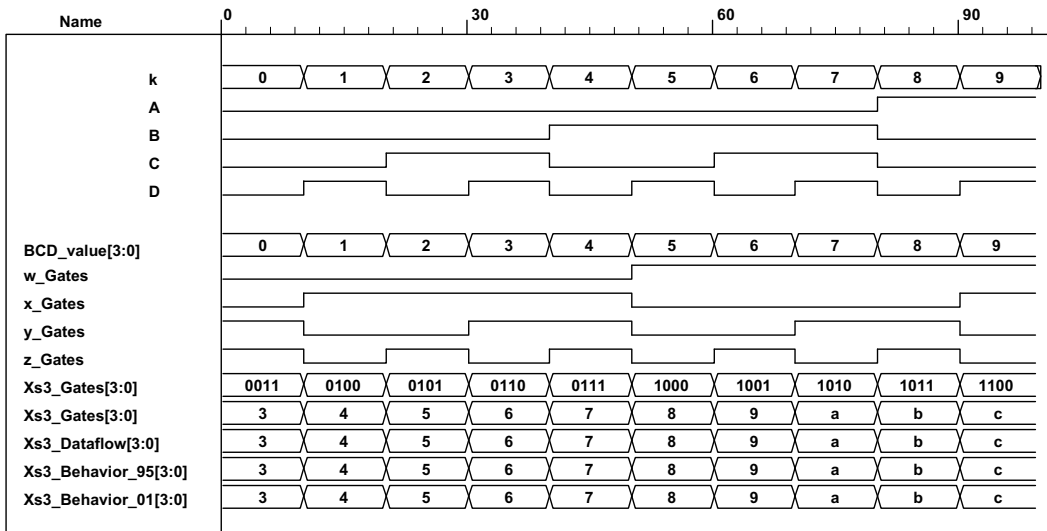

4.43 Two-channel mux with 2-bit data paths, enable, and three-state output.

4.44

```
module ALU (output reg [7: 0] y, input [7: 0] A, B, input [2: 0] Sel);
always @ (A, B, Sel) begin
    y = 0;
    case (Sel)
        3'b000: y = 8'b0;
        3'b001: y = A & B;
        3'b010: y = A | B;
        3'b011: y = A ^ B;
    endcase
end
```

```

3'b100: y = A + B;
3'b101: y = A - B;
3'b110: y = ~A;
3'b111: y = 8'hFF;
endcase
end

endmodule

module t_ALU ();
wire[7: 0]y;
reg [7: 0] A, B;
reg [2: 0] Sel;

ALU M0 (y, A, B, Sel);

initial #200 $finish;
initial fork
#5 begin A = 8'hAA; B = 8'h55; end // Expect y = 8'd0
#10 begin Sel = 3'b000; A = 8'hAA; B = 8'h55; end // y = 8'b000 Expect y = 8'd0
#20 begin Sel = 3'b001; A = 8'hAA; B = 8'hAA; end // y = A & B Expect y = 8'hAA = 8'1010_1010
#30 begin Sel = 3'b001; A = 8'h55; B = 8'h55; end // y = A & B Expect y = 8'h55 = 8'b0101_0101
#40 begin Sel = 3'b010; A = 8'h55; B = 8'h55; end // y = A | B Expect y = 8'h55 = 8'b0101_0101
#50 begin Sel = 3'b010; A = 8'hAA; B = 8'hAA; end // y = A | B Expect y = 8'hAA = 8'b1010_1010
#60 begin Sel = 3'b011; A = 8'h55; B = 8'h55; end // y = A ^ B Expect y = 8'd0
#70 begin Sel = 3'b011; A = 8'hAA; B = 8'h55; end // y = A ^ B Expect y = 8'hFF = 8'b1111_1111
#80 begin Sel = 3'b100; A = 8'h55; B = 8'h00; end // y = A + B Expect y = 8'h55 = 8'b0101_0101
#90 begin Sel = 3'b100; A = 8'hAA; B = 8'h55; end // y = A + B Expect y = 8'hFF = 8'b1111_1111
#110 begin Sel = 3'b101; A = 8'hAA; B = 8'h55; end // y = A - B Expect y = 8'h55 = 8'b0101_0101
#120 begin Sel = 3'b101; A = 8'h55; B = 8'hAA; end // y = A - B Expect y = 8'hab = 8'b1010_1011
#130 begin Sel = 3'b110; A = 8'hFF; end // y = ~A Expect y = 8'd0
#140 begin Sel = 3'b110; A = 8'd0; end // y = ~A Expect y = 8'hFF = 8'b1111_1111
#150 begin Sel = 3'b110; A = 8'hFF; end // y = ~A Expect y = 8'd0
#160 begin Sel = 3'b111; end // y = 8'hFF Expect y = 8'hFF = 8'b1111_1111
join
endmodule

```

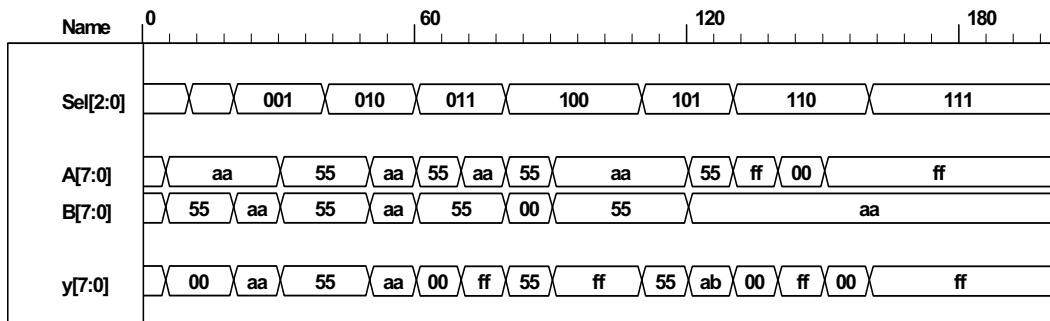

Note that the subtraction operator performs 2's complement subtraction. So 8'h55 – 8'hAA adds the 2's complement of 8'hAA to 8'h55 and gets 8'hAB. The sign bit is not included in the model, but hand calculation shows that the 9<sup>th</sup> bit is 1, indicating that the result of the operation is negative. The magnitude of the result can be obtained by taking the 2's complement of 8'hAB.

4.45

```

module priority_encoder_beh (output reg X, Y, V, input D0, D1, D2, D3); // V2001
always @ (D0, D1, D2, D3) begin
X = 0;
Y = 0;

```

```
V = 0;
case ({D0, D1, D2, D3})
  4'b0000: {X, Y, V} = 3'bxx0;
  4'b1000: {X, Y, V} = 3'b001;
  4'bx100: {X, Y, V} = 3'b011;
  4'bxx10: {X, Y, V} = 3'b101;
  4'bxxx1: {X, Y, V} = 3'b111;
  default: {X, Y, V} = 3'b000;
endcase
end
endmodule

module t_priority_encoder_beh (); // V2001
  wire X, Y, V;
  reg D0, D1, D2, D3;
  integer k;

  priority_encoder_beh M0 (X, Y, V, D0, D1, D2, D3);

  initial #200 $finish;
  initial begin
    k = 32'bx;
    #10 for (k = 0; k <= 16; k = k + 1) #10 {D0, D1, D2, D3} = k;
  end
endmodule
```

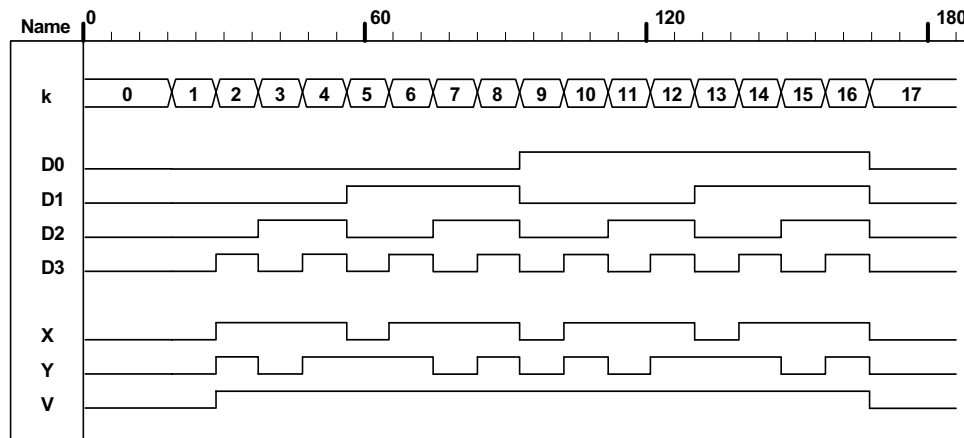

4.46

(a)  $F = \Sigma(0, 2, 5, 7, 11, 14)$   
See code below.

(b) From prob 4.32:  
 $F = \Pi(3, 8, 12) = (A' + B' + C + D)(A + B' + C' + D')(A + B + C' + D')$   
 $F' = ABC'D' + A'BCD + A'B'CD = \Sigma(12, 7, 3)$   
 $F = \Sigma(0, 1, 2, 4, 5, 6, 8, 9, 10, 11, 13, 14, 15)$

```
module Prob_4_46a (output F, input A, B, C, D);
assign F = (~A&~B&~C&~D) | (~A&~B&C&~D) | (~A&B&~C&D) | (~A&B&C&D) | (A&~B&C&D) |
(A&B&C&~D);
endmodule
```

```
module Prob_4_46b (output F, input A, B, C, D);
assign F = (~A&~B&~C&~D) | (~A&~B&~C&D) | (~A&~B&C&~D) | (~A&B&~C&~D) | (~A&B&~C&D) |
```

```
(~A&B&C&~D) | (A&~B&~C&~D) | (A&~B&~C&D) | (A&~B&C&~D) | (A&~B&C&D) | (A&B&~C&D) |
(A&B&C&~D) | (A&B&C&D);
endmodule
```

```
module t_Prob_4_46a ();
wire F_a, F_b;
reg A, B, C, D;
integer k;
Prob_4_46a M0 (F_a, A, B, C, D);
Prob_4_46b M1 (F_b, A, B, C, D);

initial #200 $finish;
initial begin
k = 0;
#10 repeat (15) begin {A, B, C, D} = k; #10 k = k + 1; end
end
endmodule
```

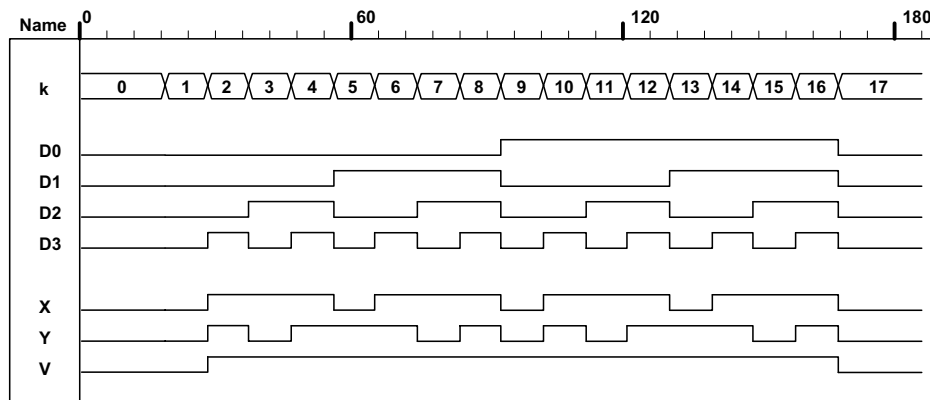

4.47

```
module Add_Sub_4_bit_Dataflow (
output [3: 0] S,
output C, V,
input [3: 0] A, B,
input M
);
wire C3;

assign {C3, S[2: 0]} = A[2: 0] + ({M, M, M} ^ B[2: 0]) + M;
assign {C, S[3]} = A[3] + M ^ B[3] + C3;
assign V = C ^ C3;
endmodule
```

```
module t_Add_Sub_4_bit_Dataflow ();
wire [3: 0] S;
wire C, V;
reg [3: 0] A, B;
reg M;

Add_Sub_4_bit_Dataflow M0 (S, C, V, A, B, M);

initial #100 $finish;
initial fork
#10 M = 0;
#10 A = 4'hA;
#10 B = 4'h5;
endfork
```



```
#50 M = 1;
#70 B = 4'h3;
join
endmodule
```

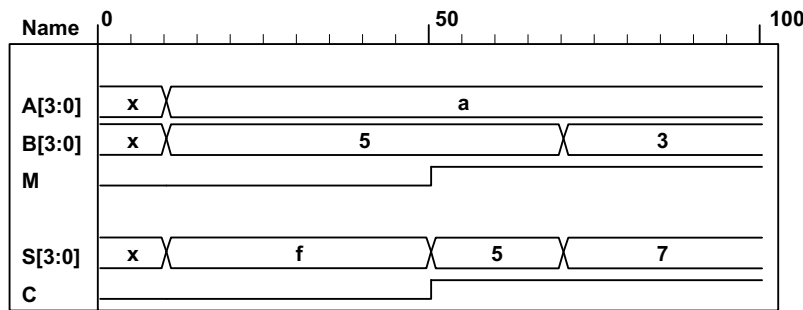

4.48

```
module ALU_3state (output [7: 0] y_tri, input [7: 0] A, B, input [2: 0] Sel, input En);
```

```
  reg [7: 0] y;
  assign y_tri = En ? y: 8'bz;
  always @ (A, B, Sel) begin
    y = 0;
    case (Sel)
      3'b000: y = 8'b0;
      3'b001: y = A & B;
      3'b010: y = A | B;
      3'b011: y = A ^ B;
      3'b100: y = A + B;
      3'b101: y = A - B;
      3'b110: y = ~A;
      3'b111: y = 8'hFF;
    endcase
  end
endmodule
```

```
endmodule
```

```
module t_ALU_3state ();
```

```
  wire[7: 0] y;
  reg [7: 0] A, B;
  reg [2: 0] Sel;
  reg En;
```

```
  ALU_3state M0 (y, A, B, Sel, En);
```

```
initial #200 $finish;
```

```
initial fork
```

```
  #5 En = 1;
```

```
  #5 begin A = 8'hAA; B = 8'h55; end // Expect y = 8'd0
```

```
  #10 begin Sel = 3'b000; A = 8'hAA; B = 8'h55; end // y = 8'b000 Expect y = 8'd0
```

```
  #20 begin Sel = 3'b001; A = 8'hAA; B = 8'hAA; end // y = A & B Expect y = 8'hAA = 8'1010_1010
```

```
  #30 begin Sel = 3'b001; A = 8'h55; B = 8'h55; end // y = A & B Expect y = 8'h55 = 8'b0101_0101
```

```
  #40 begin Sel = 3'b010; A = 8'h55; B = 8'h55; end // y = A | B Expect y = 8'h55 = 8'b0101_0101
```

```
  #50 begin Sel = 3'b010; A = 8'hAA; B = 8'hAA; end // y = A | B Expect y = 8'hAA = 8'b1010_1010
```

```
  #60 begin Sel = 3'b011; A = 8'h55; B = 8'h55; end // y = A ^ B Expect y = 8'd0
```

```
  #70 begin Sel = 3'b011; A = 8'hAA; B = 8'h55; end // y = A ^ B Expect y = 8'hFF = 8'b1111_1111
```

```
  #80 begin Sel = 3'b100; A = 8'h55; B = 8'h00; end // y = A + B Expect y = 8'h55 = 8'b0101_0101
```

```
  #90 begin Sel = 3'b100; A = 8'hAA; B = 8'h55; end // y = A + B Expect y = 8'hFF = 8'b1111_1111
```

```
  #100 En = 0;
```

```
  #115 En = 1;
```

```
#110 begin Sel = 3'b101; A = 8'hAA; B = 8'h55; end // y = A – B Expect y = 8'h55 = 8'b0101_0101
#120 begin Sel = 3'b101; A = 8'h55; B = 8'hAA; end // y = A – B Expect y = 8'hab = 8'b1010_1011
#130 begin Sel = 3'b110; A = 8'hFF; end // y = ~A Expect y = 8'd0
#140 begin Sel = 3'b110; A = 8'd0; end // y = ~A Expect y = 8'hFF = 8'b1111_1111
#150 begin Sel = 3'b110; A = 8'hFF; end // y = ~A Expect y = 8'd0
#160 begin Sel = 3'b111; end // y = 8'hFF Expect y = 8'hFF = 8'b1111_1111
join
endmodule
```

#### 4.49

```
// See Problem 4.1
module Problem_4_49_Gates (output F1, F2, input A, B, C, D);
  wire A_bar = !A;
  wire B_bar = !B;

  and (T1, B_bar, C);
  and (T2, A_bar, B);
  or (T3, A, T1);
  xor (T4, T2, D);
  or (F1, T3, T4);
  or (F2, T2, D);
endmodule

module Problem_4_49_Boolean_1 (output F1, F2, input A, B, C, D);
  wire A_bar = !A;
  wire B_bar = !B;
  wire T1 = B_bar && C;
  wire T2 = A_bar && B;
  wire T3 = A || T1;
  wire T4 = T2 ^ D;
  assign F1 = T3 || T4;
  assign F2 = T2 || D;
endmodule

module Problem_4_49_Boolean_2(output F1, F2, input A, B, C, D);
  assign F1 = A || (!B && C) || (B && !D) || (!B && D);
  assign F2 = (!A && B) || D;
endmodule

module t_Problem_4_49;
  reg A, B, C, D;
  wire F1_Gates, F2_Gates;
  wire F1_Boolean_1, F2_Boolean_1;
  wire F1_Boolean_2, F2_Boolean_2;

  Problem_4_48_Gates M0 (F1_Gates, F2_Gates, A, B, C, D);
  Problem_4_48_Boolean_1 M1 (F1_Boolean_1, F2_Boolean_1, A, B, C, D);
  Problem_4_48_Boolean_2 M2 (F1_Boolean_2, F2_Boolean_2, A, B, C, D);

  initial #100 $finish;
  integer K;
  initial begin
    for (K = 0; K < 16; K = K + 1) begin {A, B, C, D} = K; #5; end
  end
endmodule
```

#### 4.50

```
// See Problem 4.8 and Table 1.5.
// Verilog 1995

module Prob_4_50 (Code_8_4_m2_m1, A, B, C, D);
  output [3: 0] Code_8_4_m2_m1;
  input A, B, C, D;
  reg [3: 0] Code_8_4_m2_m1;
  ...

// Verilog 2001, 2005
```

```
module Prob_4_50 (output reg [3: 0] Code_8_4_m2_m1, input A, B, C, D);
```

```

always @ (A, B, C, D)           // always @ (A or B or C or D)
case ({A, B, C, D})
  4'b0000: Code_8_4_m2_m1 = 4'b0000;    // 0   0
  4'b0001: Code_8_4_m2_m1 = 4'b0111;    // 1   7
  4'b0010: Code_8_4_m2_m1 = 4'b0110;    // 2   6
  4'b0011: Code_8_4_m2_m1 = 4'b0101;    // 3   5
  4'b0100: Code_8_4_m2_m1 = 4'b0100;    // 4   4
  4'b0101: Code_8_4_m2_m1 = 4'b1011;    // 5  11
  4'b0110: Code_8_4_m2_m1 = 4'b1010;    // 6  10
  4'b0111: Code_8_4_m2_m1 = 4'b1001;    // 7   9
  4'b1000: Code_8_4_m2_m1 = 4'b1000;    // 8   8
  4'b1001: Code_8_4_m2_m1 = 4'b1111;    // 9  15

  4'b1010: Code_8_4_m2_m1 = 4'b0001;    // 10  1
  4'b1011: Code_8_4_m2_m1 = 4'b0010;    // 11  2
  4'b1100: Code_8_4_2_1   = 4'b0011;    // 12  3
  4'b1101: Code_8_4_2_1   = 4'b1100;    // 13 12
  4'b1110: Code_8_4_2_1   = 4'b1101;    // 14 13
  4'b1111: Code_8_4_2_1   = 4'b1110;    // 15 14
endcase
endmodule

```

```

module t_Prob_4_50;
  wire [3: 0] BCD;
  reg      A, B, C, D;
  integer  K;

  Prob_4_50 M0 ( BCD, A, B, C, D); // Unit under test (UUT)

  initial #100 $finish;
  initial begin
    for (K = 0; K < 16; K = K + 1) begin {A, B, C, D} = K; #5 ; end
  end
endmodule

```

**4.51** Assume that that the LEDs are asserted when the output is high.

```

module Seven_Seg_Display_V2001 (
  output reg [6: 0] Display,
  input      [3: 0] BCD
);

  //          abc_defg
  parameter BLANK      = 7'b000_0000;
  parameter ZERO       = 7'b111_1110;    // h7e
  parameter ONE        = 7'b011_0000;    // h30
  parameter TWO        = 7'b110_1101;    // h6d
  parameter THREE      = 7'b111_1001;    // h79
  parameter FOUR       = 7'b011_0011;    // h33
  parameter FIVE       = 7'b101_1011;    // h5b
  parameter SIX        = 7'b101_1111;    // h5f
  parameter SEVEN      = 7'b111_0000;    // h70
  parameter EIGHT     = 7'b111_1111;    // h7f
  parameter NINE      = 7'b111_1011;    // h7b

  always @ (BCD)
  case (BCD)
    0:    Display = ZERO;

```

```

1:   Display = ONE;
2:   Display = TWO;
3:   Display = THREE;
4:   Display = FOUR;
5:   Display = FIVE;
6:   Display = SIX;
7:   Display = SEVEN;
8:   Display = EIGHT;
9:   Display = NINE;
    default: Display = BLANK;
endcase
endmodule

module t_Seven_Seg_Display_V2001 ();
wire [6: 0] Display;
reg  [3: 0] BCD;

parameter BLANK      = 7'b000_0000;
parameter ZERO       = 7'b111_1110;    // h7e
parameter ONE        = 7'b011_0000;    // h30
parameter TWO        = 7'b110_1101;    // h6d
parameter THREE      = 7'b111_1001;    // h79
parameter FOUR       = 7'b011_0011;    // h33
parameter FIVE       = 7'b101_1011;    // h5b
parameter SIX        = 7'b001_1111;    // h1f
parameter SEVEN      = 7'b111_0000;    // h70
parameter EIGHT      = 7'b111_1111;    // h7f
parameter NINE       = 7'b111_1011;    // h7b

initial #120 $finish;
initial fork
#10 BCD = 0;
#20 BCD = 1;
#30 BCD = 2;
#40 BCD = 3;
#50 BCD = 4;
#60 BCD = 5;
#70 BCD = 6;
#80 BCD = 7;
#90 BCD = 8;
#100 BCD = 9;

join

Seven_Seg_Display_V2001 M0 (Display, BCD);
endmodule

```

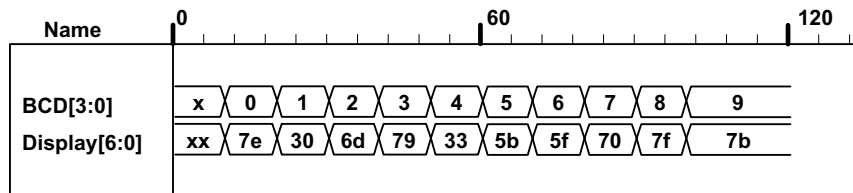

Alternative with continuous assignments (dataflow):

```

module Seven_Seg_Display_V2001_CA (
output [6: 0] Display,
input [3: 0] BCD
);

```

```
//          abc_defg
parameter BLANK = 7'b000_0000;
parameter ZERO  = 7'b111_1110;    // h7e
parameter ONE   = 7'b011_0000;    // h30
parameter TWO   = 7'b110_1101;    // h6d
parameter THREE = 7'b111_1001;    // h79
parameter FOUR  = 7'b011_0011;    // h33
parameter FIVE  = 7'b101_1011;    // h5b
parameter SIX   = 7'b101_1111;    // h5f
parameter SEVEN = 7'b111_0000;    // h70
parameter EIGHT = 7'b111_1111;    // h7f
parameter NINE  = 7'b111_1011;    // h7b
wire         A, B, C, D, a, b, c, d, e, f, g;

assign A = BCD[3];
assign B = BCD[2];
assign C = BCD[1];
assign D = BCD[0];
assign Display = {a,b,c,d,e,f,g};
assign a = (~A)&C | (~A)&B&D | (~B)&(~C)&(~D) | A & (~B)&(~C);
assign b = (~A)&(~B) | (~A)&(~C)&(~D) | (~A)&C&D | A&(~B)&(~C);
assign c = (~A)&B | (~A)&D | (~B)&(~C)&(~D) | A&(~B)&(~C);
assign d = (~A)&C&(~D) | (~A)&(~B)&C | (~B)&(~C)&(~D) | A&(~B)&(~C) | (~A)&B&(~C)&D;
assign e = (~A)&C&(~D) | (~B)&(~C)&(~D);
assign f = (~A)&B&(~C) | (~A)&(~C)&(~D) | (~A)&B&(~D) | A&(~B)&(~C);
assign g = (~A)&C&(~D) | (~A)&(~B)&C | (~A)&B&(~C) | A&(~B)&(~C);
endmodule

module t_Seven_Seg_Display_V2001_CA ();
wire [6: 0] Display;
reg [3: 0] BCD;

parameter BLANK = 7'b000_0000;
parameter ZERO  = 7'b111_1110;    // h7e
parameter ONE   = 7'b011_0000;    // h30
parameter TWO   = 7'b110_1101;    // h6d
parameter THREE = 7'b111_1001;    // h79
parameter FOUR  = 7'b011_0011;    // h33
parameter FIVE  = 7'b101_1011;    // h5b
parameter SIX   = 7'b001_1111;    // h1f
parameter SEVEN = 7'b111_0000;    // h70
parameter EIGHT = 7'b111_1111;    // h7f
parameter NINE  = 7'b111_1011;    // h7b

initial #120 $finish;
initial fork
  #10 BCD = 0;
  #20 BCD = 1;
  #30 BCD = 2;
  #40 BCD = 3;
  #50 BCD = 4;
  #60 BCD = 5;
  #70 BCD = 6;
  #80 BCD = 7;
  #90 BCD = 8;
  #100 BCD = 9;
join

  Seven_Seg_Display_V2001_CA M0 (Display, BCD);
```

**endmodule**

**4.52 (a) Incrementer for unsigned 4-bit numbers**

```
module Problem_4_52a_Data_Flow (output [3: 0] sum, output carry, input [3: 0] A);
  assign {carry, sum} = A + 1;
endmodule
```

```
module t_Problem_4_52a_Data_Flow;
  wire [3: 0] sum;
  wire carry;
  reg [3: 0] A;

  Problem_4_52a_Data_Flow M0 (sum, carry, A);

  initial # 100 $finish;
  integer K;
  initial begin
    for (K = 0; K < 16; K = K + 1) begin A = K; #5; end
  end
endmodule
```

**(b) Decrementer for unsigned 4-bit numbers**

```
module Problem_4_52b_Data_Flow (output [3: 0] diff, output borrow, input [3: 0] A);
  assign {borrow, diff} = A - 1;
endmodule
```

```
module t_Problem_4_52b_Data_Flow;
  wire [3: 0] diff;
  wire borrow;
  reg [3: 0] A;

  Problem_4_52b_Data_Flow M0 (diff, borrow, A);

  initial # 100 $finish;
  integer K;
  initial begin
    for (K = 0; K < 16; K = K + 1) begin A = K; #5; end
  end
endmodule
```

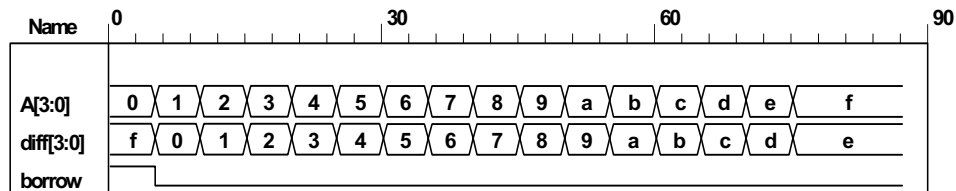

**4.53 // BCD Adder**

```

module Problem_4_53_BCD_Adder (
  output      Output_carry,
  output [3: 0] Sum,
  input [3: 0] Addend, Augend,
  input      Carry_in;
  supply0   gnd;
  wire [3: 0] Z_Addend;
  wire      Carry_out;
  wire      C_out;
  assign Z_Addend = {1'b0, Output_carry, Output_carry, 1'b0};
  wire [3: 0] Z_sum;

  and (w1, Z_sum[3], Z_sum[2]);
  and (w2, Z_sum[3], Z_sum[1]);
  or (Output_carry, Carry_out, w1, w2);

  Adder_4_bit M0 (Carry_out, Z_sum, Addend, Augend, Carry_in);
  Adder_4_bit M1 (C_out, Sum, Z_Addend, Z_sum, gnd);
endmodule

module Adder_4_bit (output carry, output [3:0] sum, input [3: 0] a, b, input c_in);
  assign {carry, sum} = a + b + c_in;
endmodule

module t_Problem_4_53_Data_Flow;
  wire [3: 0] Sum;
  wire      Output_carry;
  reg [3: 0] Addend, Augend;
  reg      Carry_in;

  Problem_4_53_BCD_Adder M0 (Output_carry, Sum, Addend, Augend, Carry_in);

  initial # 1500 $finish;
  integer i, j, k;
  initial begin
    for (i = 0; i <= 1; i = i + 1) begin Carry_in = i; #5;
    for (j = 0; j <= 9; j = j + 1) begin Addend = j; #5;
    for (k = 0; k <= 9; k = k + 1) begin Augend = k; #5;
    end
  end
  end
  end
  end
endmodule

```

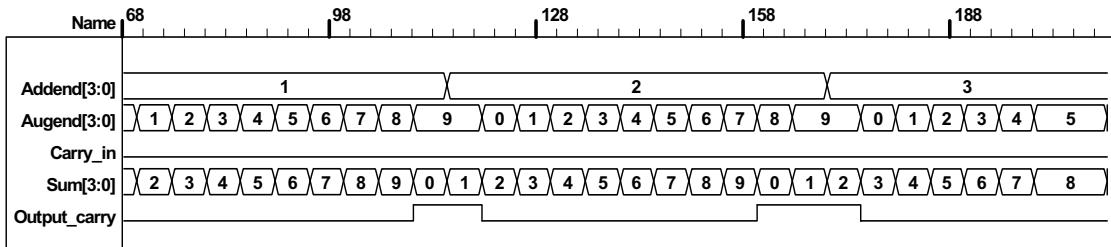

4.54

```

module Nines_Complementer (           // V2001
  output reg [3: 0] Word_9s_Comp,
  input      [3: 0] Word_BCD
);
always @ (Word_BCD) begin
  Word_9s_Comp = 4'b0;
  case (Word_BCD)
    4'b0000: Word_9s_Comp = 4'b1001;    // 0 to 9
    4'b0001: Word_9s_Comp = 4'b1000;    // 1 to 8
    4'b0010: Word_9s_Comp = 4'b1111;    // 2 to 7
    4'b0011: Word_9s_Comp = 4'b0110;    // 3 to 6
    4'b0100: Word_9s_Comp = 4'b1001;    // 4 to 5
    4'b0101: Word_9s_Comp = 4'b0100;    // 5 to 4
    4'b0110: Word_9s_Comp = 4'b0011;    // 6 to 3
    4'b0111: Word_9s_Comp = 4'b0010;    // 7 to 2
    4'b1000: Word_9s_Comp = 4'b0001;    // 8 to 1
    4'b1001: Word_9s_Comp = 4'b0000;    // 9 to 0
    default: Word_9s_Comp = 4'b1111;    // Error detection
  endcase
end
endmodule

module t_Nines_Complementer ();
  wire [3: 0] Word_9s_Comp;
  reg [3: 0] Word_BCD;

  Nines_Complementer M0 (Word_9s_Comp, Word_BCD);

  initial #11$finish;
  initial fork
    Word_BCD = 0;
  #10 Word_BCD = 1;
  #20 Word_BCD = 2;
  #30 Word_BCD = 3;
  #40 Word_BCD = 4;
  #50 Word_BCD = 5;
  #60 Word_BCD = 6;
  #70 Word_BCD = 7;
  #20 Word_BCD = 8;
  #90 Word_BCD = 9;
  #100 Word_BCD = 4'b1100;
  join
endmodule

```

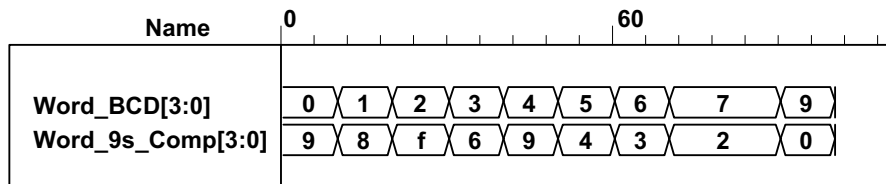



4.55 From Problem 4.19:

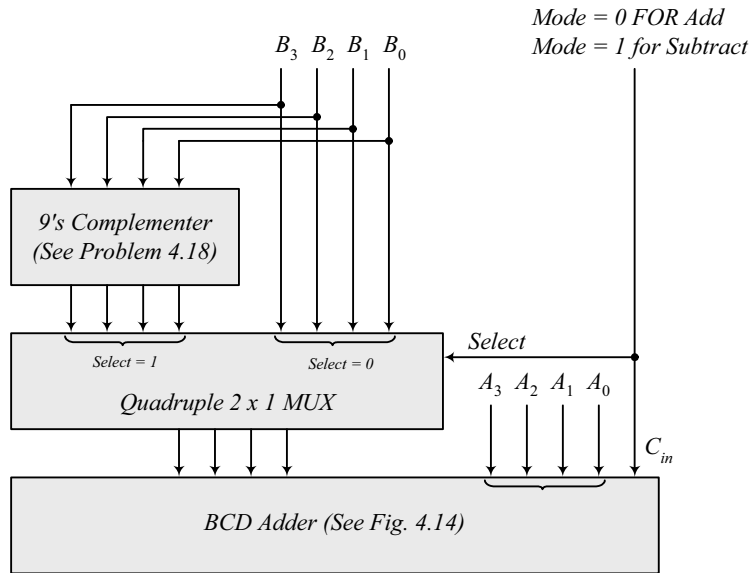

```
// BCD Adder – Subtractor
module Problem_4_55_BCD_Adder_Subtractor (
  output [3: 0]   BCD_Sum_Diff,
  output         Carry_Borrow,
  input [3: 0]   B, A,
  input         Mode
);
  wire [3: 0] Word_9s_Comp, mux_out;
  Nines_Complementer  M0 (Word_9s_Comp, B);
  Quad_2_x_1_mux      M2 (mux_out, Word_9s_Comp, B, Mode);
  BCD_Adder           M1 (Carry_Borrow, BCD_Sum_Diff, mux_out, A, Mode);
endmodule

module Nines_Complementer ( // V2001
  output reg [3: 0] Word_9s_Comp,
  input [3: 0] Word_BCD
);
  always @ (Word_BCD) begin
    Word_9s_Comp = 4'b0;
    case (Word_BCD)
      4'b0000: Word_9s_Comp = 4'b1001; // 0 to 9
      4'b0001: Word_9s_Comp = 4'b1000; // 1 to 8
      4'b0010: Word_9s_Comp = 4'b0111; // 2 to 7
      4'b0011: Word_9s_Comp = 4'b0110; // 3 to 6
      4'b0100: Word_9s_Comp = 4'b1001; // 4 to 5
      4'b0101: Word_9s_Comp = 4'b0100; // 5 to 4
      4'b0110: Word_9s_Comp = 4'b0011; // 6 to 3
      4'b0111: Word_9s_Comp = 4'b0010; // 7 to 2
      4'b1000: Word_9s_Comp = 4'b0001; // 8 to 1
      4'b1001: Word_9s_Comp = 4'b0000; // 9 to 0
      default: Word_9s_Comp = 4'b1111; // Error detection
    endcase
  end
endmodule
```

```
module Quad_2_x_1_mux (output reg [3: 0] mux_out, input [3: 0] b, a, input select);
always @ (a, b, select)
  case (select)
    0: mux_out = a;
    1: mux_out = b;
  endcase
endmodule

module BCD_Adder (
  output      Output_carry,
  output [3: 0] Sum,
  input  [3: 0] Addend, Augend,
  input      Carry_in);
supply0      gnd;
wire  [3: 0] Z_Addend;
wire      Carry_out;
wire      C_out;
assign Z_Addend = {1'b0, Output_carry, Output_carry, 1'b0};
wire [3: 0] Z_sum;

  and (w1, Z_sum[3], Z_sum[2]);
  and (w2, Z_sum[3], Z_sum[1]);
  or (Output_carry, Carry_out, w1, w2);

  Adder_4_bit M0 (Carry_out, Z_sum, Addend, Augend, Carry_in);
  Adder_4_bit M1 (C_out, Sum, Z_Addend, Z_sum, gnd);
endmodule

module Adder_4_bit (output carry, output [3:0] sum, input [3: 0] a, b, input c_in);
  assign {carry, sum} = a + b + c_in;
endmodule

module t_Problem_4_55_BCD_Adder_Subtractor();
wire [3: 0] BCD_Sum_Diff;
wire      Carry_Borrow;
reg  [3: 0] B, A;
reg      Mode;

  Problem_4_55_BCD_Adder_Subtractor M0 (BCD_Sum_Diff, Carry_Borrow, B, A, Mode);

  initial #1000 $finish;

  integer J, K, M;
  initial begin
    for (M = 0; M < 2; M = M + 1) begin
      for (J = 0; J < 10; J = J + 1) begin
        for (K = 0; K < 10; K = K + 1) begin
          A = J; B = K; Mode = M; #5 ;
        end
      end
    end
  endmodule
```

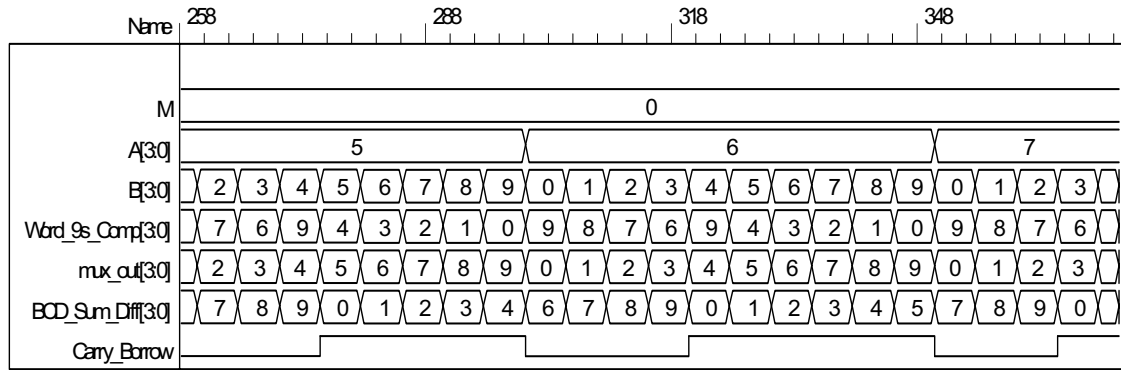

Note: For subtraction, Carry\_Borrow = 1 indicates a positive result; Carry\_Borrow = 0 indicates a negative result.

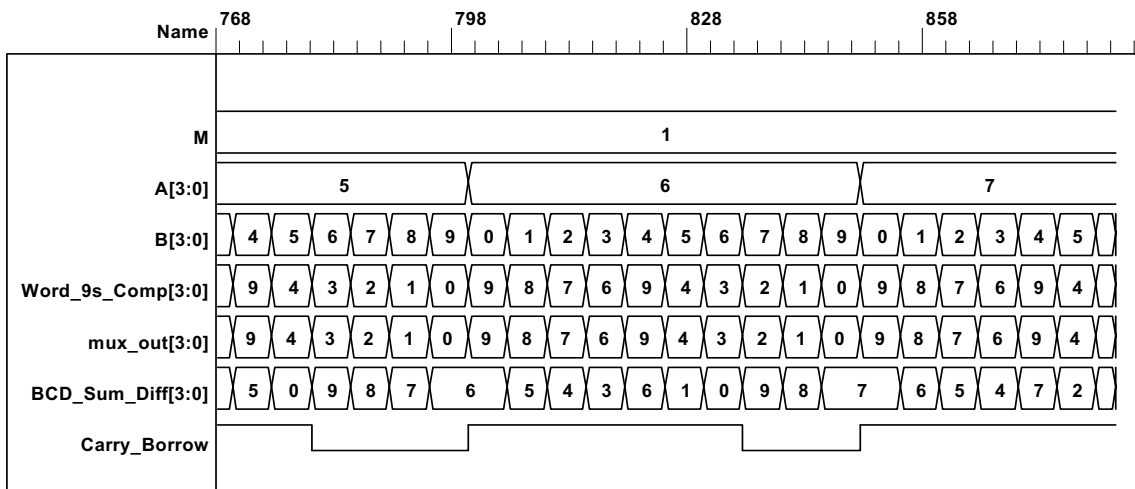

4.56

```
assign match = (A == B); // Assumes reg [3: 0] A, B;
```

4.57

```
// Priority encoder (See Problem 4.29)
// Caution: do not confuse logic value x with identifier x.
// Verilog 1995
```

```
module Prob_4_57 (x, y, v, D3, D2, D1, D0);
output x, y, v;
input D3, D2, D1, D0;
reg x, y, v;
...
```

```
// Verilog 2001, 2005
```

```
module Prob_4_57 (output reg x, y, v, input D3, D2, D1, D0);
always @ (D3, D2, D1, D0) begin // always @ (D3 or D2 or D1 or D0)
x = 0;
y = 0;
v = 0;
casex ({D3, D2, D1, D0})
4'b0000: {x, y, v} = 3'bxx0;
4'bxxx1: {x, y, v} = 3'b001;
endcase
end
```

```

4'bx10: {x, y, v} = 3'b011;
4'bx100: {x, y, v} = 3'b101;
4'bx1000: {x, y, v} = 3'b110;
endcase
end
endmodule

module t_Prob_4_57;
wire x, y, v;
reg D3, D2, D1, D0;
integer K;
Prob_4_57 M0 (x, y, v, D3, D2, D1, D0);
initial #100 $finish;
initial begin
for (K = 0; K < 16; K = K + 1) begin {D3, D2, D1, D0} = K; #5 ; end
end
endmodule

```

4.58

```

//module shift_right_by_3_V2001 (output [31: 0] sig_out, input [31: 0] sig_in);
// assign sig_out = sig_in >>> 3;
//endmodule

module shift_right_by_3_V1995 (output reg [31: 0] sig_out, input [31: 0] sig_in);
always @ (sig_in)
sig_out = {sig_in[31], sig_in[31], sig_in[31], sig_in[31: 3]};
endmodule

module t_shift_right_by_3 ();
wire [31: 0] sig_out_V1995;
wire [31: 0] sig_out_V2001;

reg [31: 0] sig_in;

//shift_right_by_3_V2001 M0 (sig_out_V2001, sig_in);

shift_right_by_3_V1995 M1 (sig_out_V1995, sig_in);
integer k;
initial #1000 $finish;
initial begin
sig_in = 32'hf000_0000;
#100 sig_in = 32'h8fff_ffff;
#500 sig_in = 32'h0fff_ffff;
end
endmodule

```

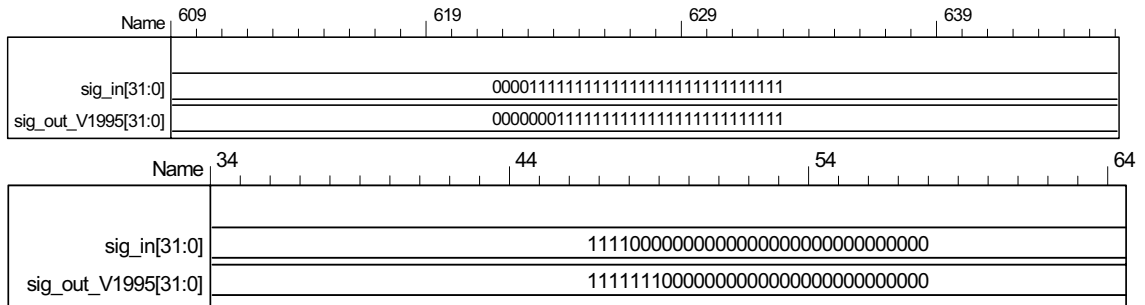

4.59

```

//module shift_left_by_3_V2001 (output [31: 0] sig_out, input [31: 0] sig_in);
// assign sig_out = sig_in <<< 3;
//endmodule

module shift_left_by_3_V1995 (output reg [31: 0] sig_out, input [31: 0] sig_in);
  always @ (sig_in)
    sig_out = {sig_in[28: 0], 3'b0};
endmodule

module t_shift_left_by_3 ();
  wire [31: 0] sig_out_V1995;
  //wire [31: 0] sig_out_V2001;

  reg [31: 0] sig_in;

  //shift_left_by_3_V2001 M0 (sig_out_V2001, sig_in);

  shift_left_by_3_V1995 M1 (sig_out_V1995, sig_in);
  integer k;
  initial #500 $finish;
  initial begin
    #100 sig_in = 32'h0000_000f;
  end
endmodule

```

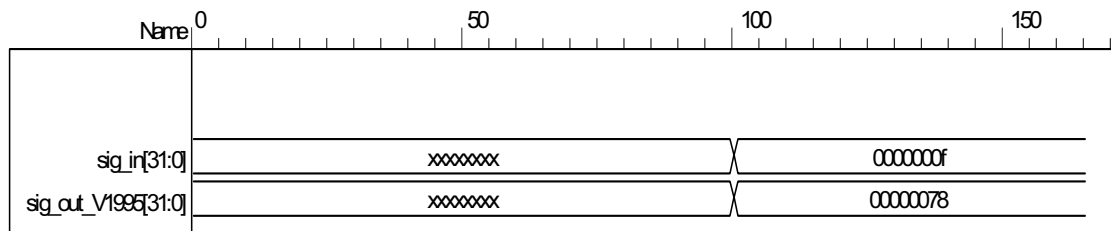

4.60

```

module BCD_to_Decimal (output reg [3: 0] Decimal_out, input [3: 0] BCD_in);
  always @ (BCD_in) begin
    Decimal_out = 0;
    case (BCD_in)
      4'b0000: Decimal_out = 0;
      4'b0001: Decimal_out = 1;
      4'b0010: Decimal_out = 2;
      4'b0011: Decimal_out = 3;
      4'b0100: Decimal_out = 4;
      4'b0101: Decimal_out = 5;
      4'b0110: Decimal_out = 6;
      4'b0111: Decimal_out = 7;
      4'b1000: Decimal_out = 8;
      4'b1001: Decimal_out = 9;
      default: Decimal_out = 4'bxxxx;
    endcase
  end
endmodule

```

4.61

```

module Even_Parity_Checker_4 (output P, C, input x, y, z);
  xor (w1, x, y);
  xor (P, w1, z);
  xor (C, w1, w2);

```

```
xor (w2, z, P);
endmodule
```

See Problem 4.62 for testbench and waveforms.

4.62

```
module Even_Parity_Checker_4 (output P, C, input x, y, z);
  assign w1 = x ^ y;
  assign P = w1 ^ z;
  assign C = w1 ^ w2;
  assign w2 = z ^ P;
endmodule
```

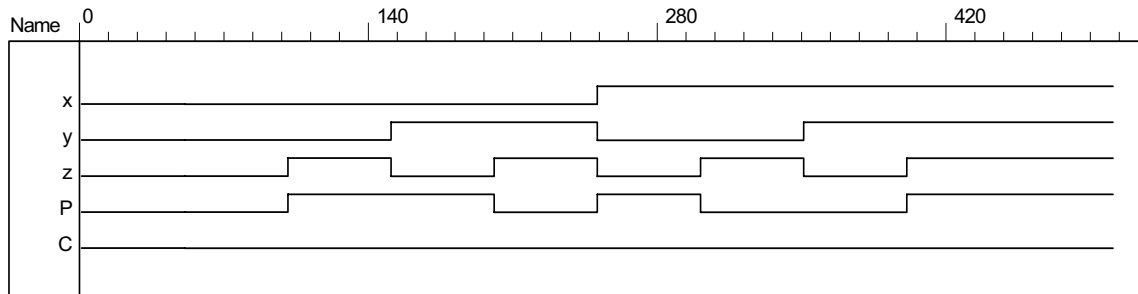

## CHAPTER 5

5.1 (a)

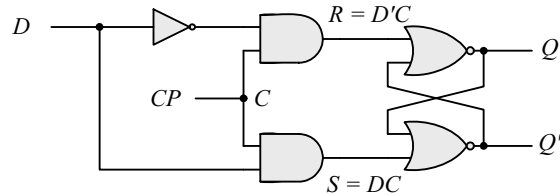

(b)

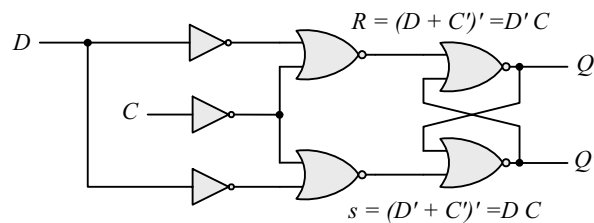

(c)

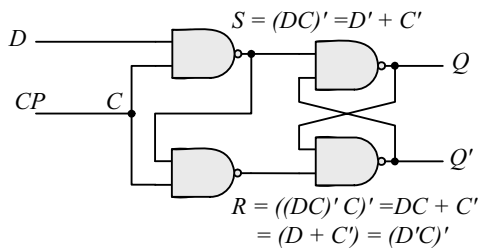

5.2

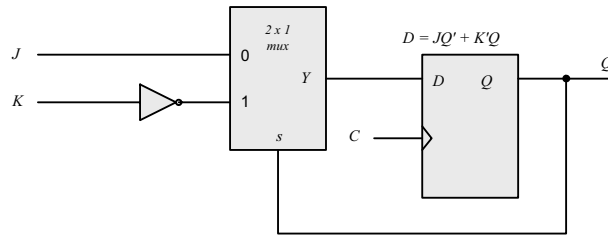

5.3  $Q'(t + 1) = (JQ' + K'Q)' = (J' + Q)(K + Q') = J'Q' + KQ$

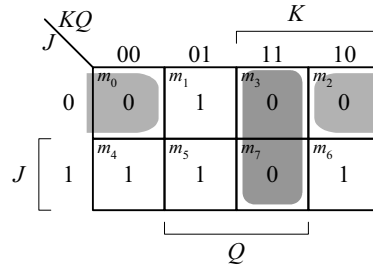

5.4

(a)

P	N	Q(t+1)
0	0	0
0	1	Q(t)
1	0	Q'(t)
1	1	1

(b)

P	N	Q(t)	Q(t+1)
0	0	0	0
0	0	1	0
0	1	0	0
0	1	1	1
1	0	0	1
1	0	1	0
1	1	0	1
1	1	1	1

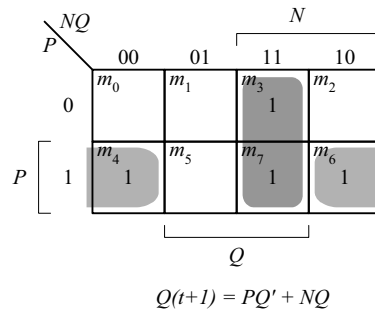

(c)

Q(t)	Q(t+1)	P	N
0	0	0	x
0	1	1	x
1	0	x	0
1	1	x	1

(d) Connect P and N together.

5.5

The truth table describes a combinational circuit.  
 The state table describes a sequential circuit.  
 The characteristic table describes the operation of a flip-flop.  
 The excitation table gives the values of flip-flop inputs for a given state transition.  
 The four equations correspond to the algebraic expression of the four tables.

5.6 (a)

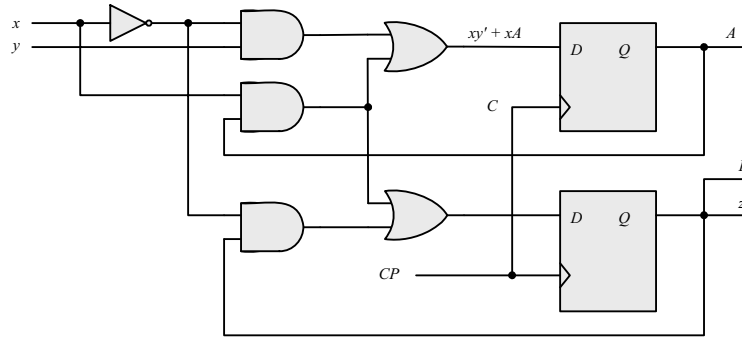

(b)

Present state		Inputs		Next state			Output
A	B	x	y	A	B	z	
0	0	0	0	0	0	0	0
0	0	0	1	1	0	0	0
0	0	1	0	0	0	0	0
0	0	1	1	0	0	0	0
0	1	0	0	0	1	1	1
0	1	0	1	1	1	1	1
0	1	1	0	0	0	1	1
0	1	1	1	0	0	1	1
1	0	0	0	0	0	0	0
1	0	0	1	1	0	0	0
1	0	1	0	1	1	0	0
1	0	1	1	1	1	0	0
1	1	0	0	0	1	1	1
1	1	0	1	1	1	1	1
1	1	1	0	1	1	1	1
1	1	1	1	1	1	1	1

(c)

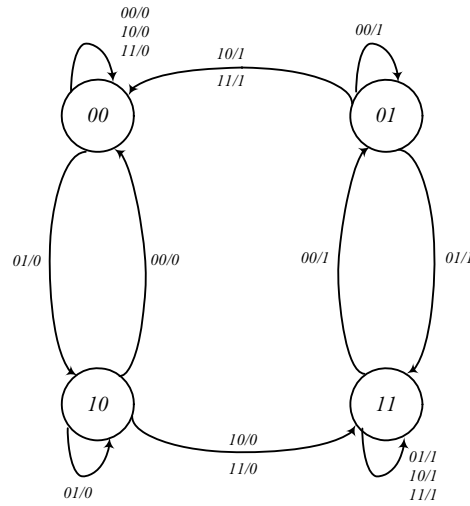

5.7

Present state	Inputs		Next state	Output
Q	x	y	Q	S
0	0	0	0	0
0	0	1	0	1
0	1	0	0	1
0	1	1	1	0
1	0	0	0	1
1	0	1	1	0
1	1	0	1	0
1	1	1	1	1

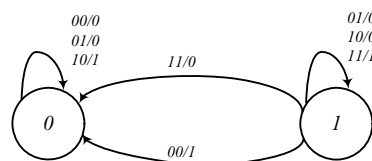

$$S = x \oplus y \oplus Q$$

$$Q(t + 1) = xy + xQ + yQ$$



**5.8** A counter with a repeated sequence of 00, 01, 10.

Present state		Next state		FF Inputs	
A	B	A	B	$T_A$	$T_B$
0	0	0	0	0	1
0	1	1	0	1	1
1	0	0	0	1	0
1	1	0	0	1	1

$$T_A = A + B$$

$$T_B = A' + B$$

Repeated sequence:

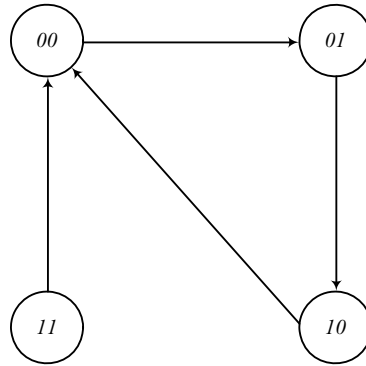
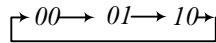

**5.9**

$$A(t+1) = J_A A' + K' A = xA' + BA$$

$$B(t+1) = J_B B' + K' B = xB' + A'B$$

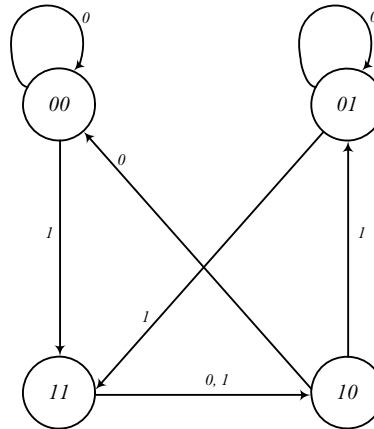

**5.10 (a)**  $J_A = Bx + B'y'$        $J_B = A'x$   
 $K_A = B'xy'$                $K_B = A + xy'$        $z = Axy + Bx'y'$

**(b)**

Present state		Inputs		Next state		Output	FF Outputs			
A	B	x	y	A	B		z	$J_A$	$K_A$	$J_B$
0	0	0	0	1	0	0	1	0	0	0
0	0	0	1	0	0	0	0	0	0	0
0	0	1	0	1	1	0	1	1	1	1
0	0	1	1	0	1	0	0	0	1	0
0	1	0	0	0	1	1	0	0	0	0
0	1	0	1	0	1	0	0	0	0	0
0	1	1	0	1	0	0	1	0	1	0
0	1	1	1	1	1	0	1	0	1	0
1	0	0	0	1	0	0	1	0	0	1
1	0	0	1	1	0	0	0	0	0	1
1	0	1	0	0	0	0	1	1	0	1
1	0	1	1	1	0	0	0	0	0	1
1	1	0	0	1	0	1	0	0	0	1
1	1	0	1	1	0	0	0	0	0	1
1	1	1	0	1	0	0	1	0	0	1
1	1	1	1	1	0	1	1	0	0	1

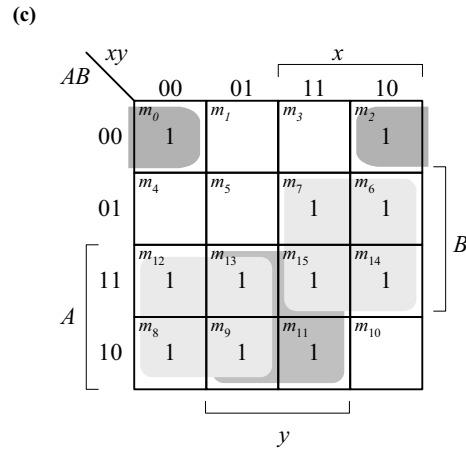

$$A(t+1) = Ax' + Bx + Ay + A'B'y'$$

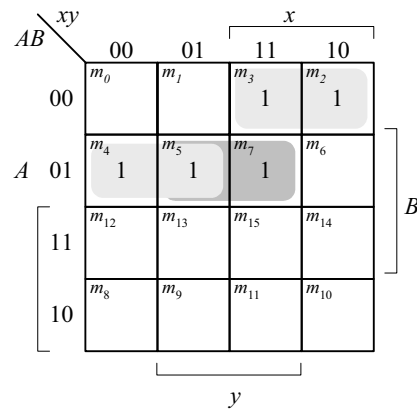

$$B(t+1) = A'B'x + A'B'(x' + y)$$

**5.11** Present state: 00 00 01 00 01 11 00 01 11 10 00 01 11 10 10  
 Input: 0 1 0 1 1 0 1 1 1 0 1 1 1 1 0  
 Output: 0 0 1 0 0 1 0 0 0 1 0 0 0 0 1  
 Next state: 00 01 00 01 11 00 01 11 10 00 01 11 10 10 00

**5.12**

Present state	Next state		Output	
	0	1	0	1
a	f	b	0	0
b	d	a	0	0
d	g	a	1	0
f	f	b	1	1
g	g	d	0	1

- 5.13**
- (a) State: *a f b c e d g h g g h a*  
 Input: 0 1 1 1 0 0 1 0 0 1 1  
 Output: 0 1 0 0 0 1 1 1 0 1 0
- (b) State: *a f b a b d g d g g d a*  
 Input: 0 1 1 1 0 0 1 0 0 1 1  
 Output: 0 1 0 0 0 1 1 1 0 1 0

**5.14**

	Present state			Next state		Output	
	A	B	C	x=0	x=1	x=1	x=0
a	0	0	0	000	001	0	0
b	0	0	1	011	010	0	0
c	0	1	1	000	010	0	0
d	0	1	0	110	010	0	1
e	1	1	0	000	010	0	1

**5.15**  $D_Q = Q'J + QK'$

Present state	Inputs		Next state	Q
	Q	J K		
0	0	0	0	No change
0	0	1	0	Reset to 0
0	1	0	1	Set to 1
0	1	1	1	Complement
1	0	0	1	No change
1	0	1	0	Reset to 0
1	1	0	1	Set to 1
1	1	1	0	Complement

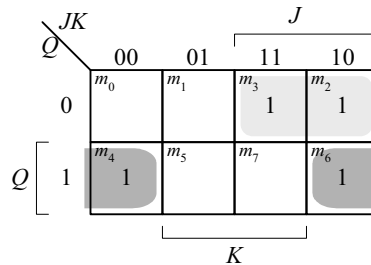

$Q(t+1) = D_Q + Q'J + QK'$

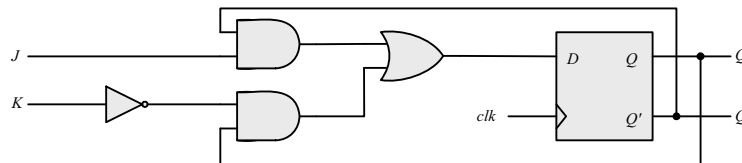

- 5.16** (a)  $D_A = Ax' + Bx$   
 $D_B = A'x + Bx'$

Present state		Input	Next state	
A	B	x	A	B
0	0	0	0	0
0	0	1	0	1
0	1	0	0	1
0	1	1	1	1
1	0	0	1	0
1	0	1	0	0
1	1	0	1	1
1	1	1	1	0

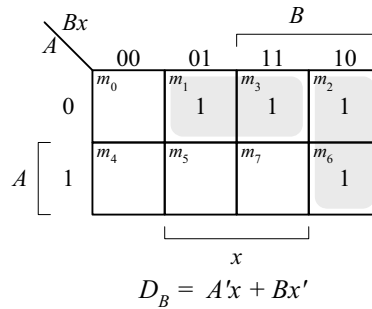
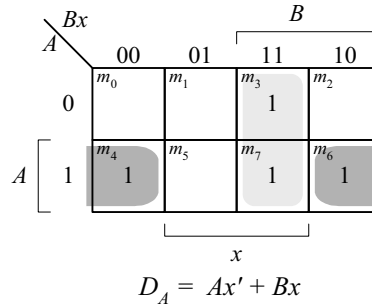

(b)  $D_A = A'x + Ax'$

$D_B = AB + Bx'$

Present state		Input	Next state	
A	B	x	A	B
0	0	0	0	0
0	0	1	1	1
0	1	0	0	1
0	1	1	1	0
1	0	0	1	0
1	0	1	0	0
1	1	0	1	1
1	1	1	0	1

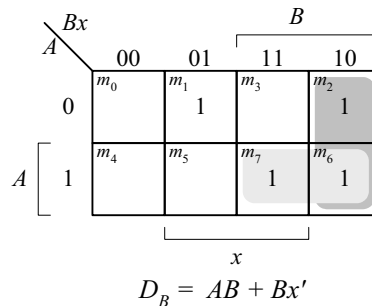
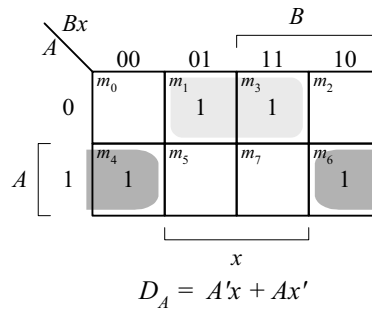

**5.17** The output is 0 for all 0 inputs until the first 1 occurs, at which time the output is 1. Thereafter, the output is the complement of the input. The state diagram has two states. In state 0: output = input; in state 1: output = input'.

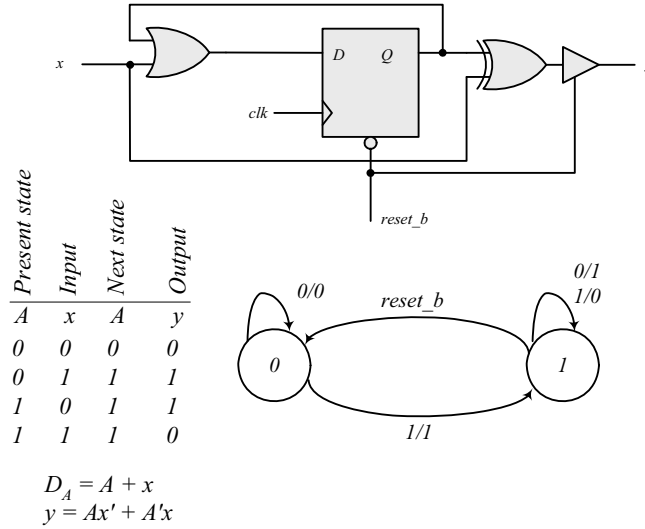

**5.18** Binary up-down counter with enable *E*.

Present state	Input	Next state	Flip-flop inputs			
			$J_A$	$K_A$	$J_B$	$K_B$
A B	x	A B				
00	01	00	0	x	0	x
00	01	00	0	x	0	x
00	10	11	1	x	1	x
00	11	01	0	x	1	x
01	00	01	0	x	x	0
01	01	01	0	x	x	0
01	10	01	0	x	x	1
01	11	10	1	x	x	1
10	00	10	x	0	1	0
10	01	10	x	0	1	0
10	10	01	x	1	x	1
10	11	11	x	0	x	1
11	00	11	x	0	x	0
11	01	11	x	0	x	0
11	10	11	1	0	x	1
11	11	11	x	1	x	1

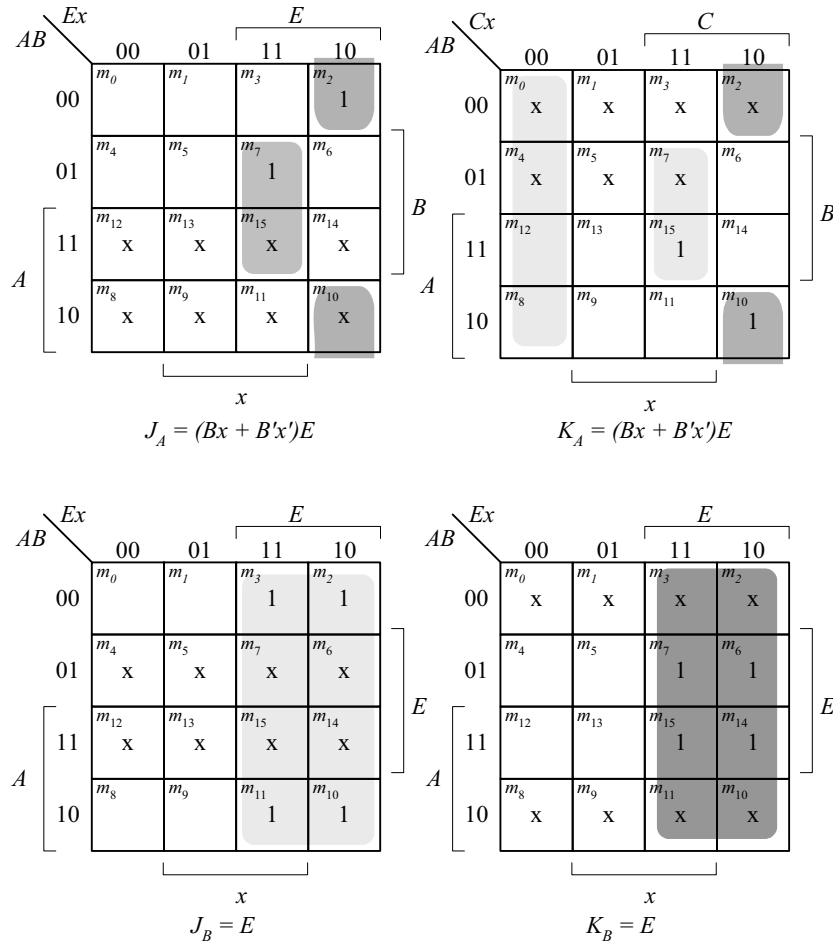

5.19 (a) Unused states (see Fig. P5.19): 101, 110, 111.

Present state	Input	Next state	Output
ABC	x	ABC	y
000	0	011	0
000	1	100	1
001	0	001	0
001	1	100	1
010	0	010	0
010	1	000	1
011	0	001	0
011	1	010	1
100	0	010	0
100	1	011	1

$$d(A, B, C, x) = \Sigma (10, 11, 12, 13, 14, 15)$$

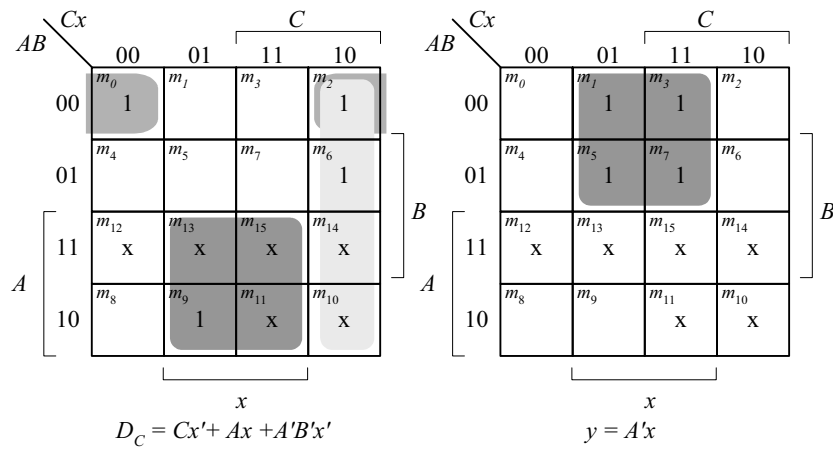
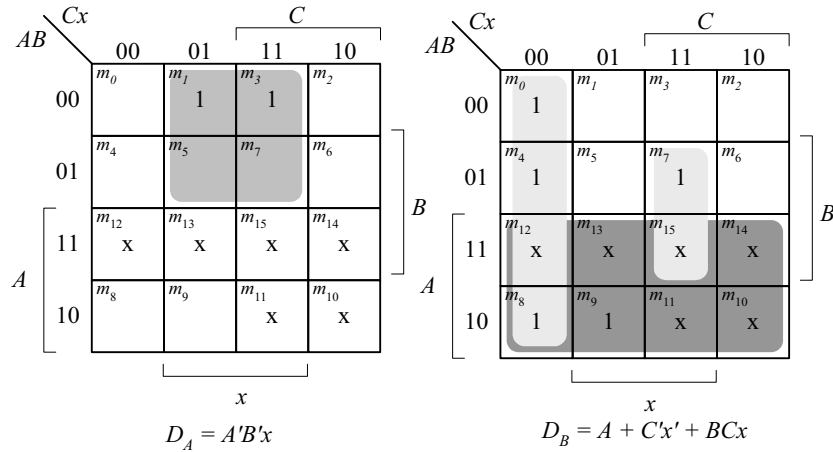

The machine is self-correcting, i.e., the unused states transition to known states.

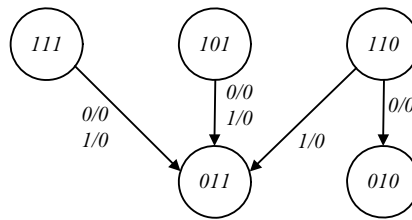

(b) With JK flip=flops, the state table is the same as in (a).

*Flip-flop inputs*

$J_A$	$K_A$	$J_B$	$K_B$	$J_C$	$K_C$
0	x	1	x	1	x
1	x	0	x	0	x
0	x	0	x	x	0
1	x	0	x	x	1
0	x	x	0	0	x
0	x	x	1	0	x
0	x	x	1	x	0
0	x	x	0	x	1
x	1	1	x	0	x
x	1	1	x	1	x

$J_A = B'x$        $K_A = 1$   
 $J_B = A + C'x'$        $K_B = C'x + Cx'$   
 $J_C = Ax + A'B'x'$        $K_C = x$   
 $y = A'x$   
 The machine is self-correcting  
 because  $K_A = 1$ .

5.20 From state table 5.4:  $T_A(A, B, x) = \Sigma(2, 3, 6)$ ,  $T_B(A, B, x) = \Sigma(0, 3, 4, 6)$ .

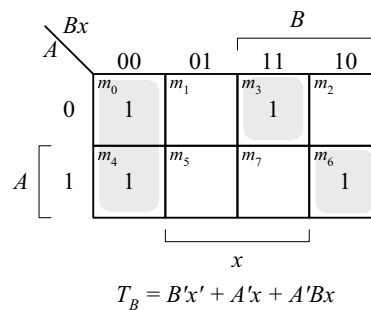
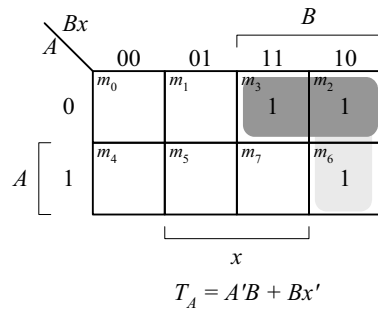

5.21 The statements associated with an **initial** keyword execute once, in sequence, with the activity expiring after the last statement completes execution; the statements associated with the **always** keyword execute repeatedly, subject to timing control (e.g, #10).

5.22

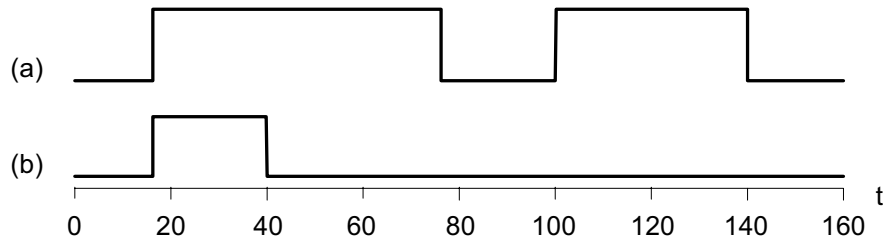

5.23 (a)  $RegA = 125$ ,  $RegB = 125$   
 (b)  $RegA = 125$ ,  $RegB = 30$



5.24 (a)

```

module DFF (output reg Q, input D, clk, preset, clear);
  always @ (posedge clk, negedge preset, negedge clear )
    if (preset == 0) Q <= 1'b1;
    else if (clear == 0) Q <= 1'b0;
    else Q <= D;
endmodule

```

```

module t_DFF ();
  wire Q;
  reg clk, preset, clear;
  reg D;

```

```

DFF M0 (Q, D, clk, preset, clear);

```

```

initial #160 $finish;
initial begin clk = 0; forever #5 clk = ~clk; end
initial fork
  #10 preset = 0;
  #20 preset = 1;
  #50 clear = 0;
  #80 clear = 1;
  #10 D = 1;
  #100 D = 0;
  #200 D = 1;
join
endmodule

```

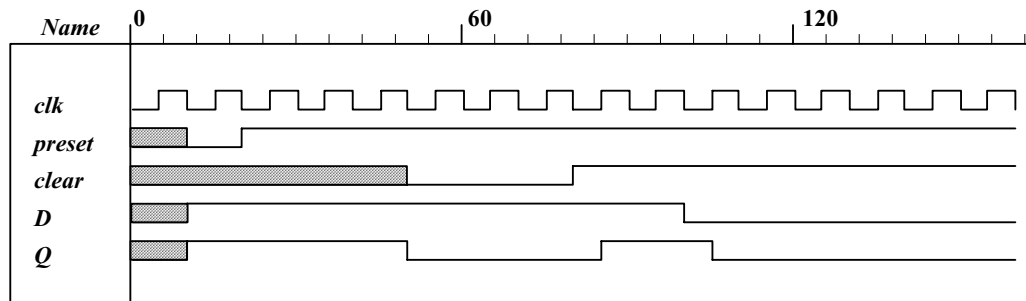

```

(b) module DFF (output reg Q, input D, clk, preset, clear);
  always @ (posedge clk)
    if (preset == 0) Q <= 1'b1;
    else if (clear == 0) Q <= 1'b0;
    else Q <= D;
endmodule

```

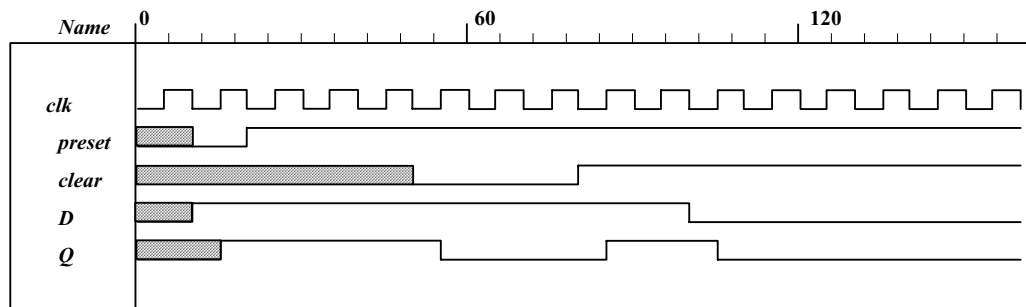

5.25

```

module Dual_Input_DFF (output reg Q, input D1, D2, select, clk, reset_b);
  always @ (posedge clk, negedge reset_b)
    if (reset_b == 0) Q <= 0;
    else Q <= select ? D2 : D1;
endmodule

module t_Dual_Input_DFF ();
  wire Q;
  reg D1, D2, select, clk, reset_b;
  Dual_Input_DFF M0 (Q, D1, D2, select, clk, reset_b);
  initial #350$finish;
  initial begin clk = 0; forever #5 clk = ~clk; end
  initial fork
    select = 0;
    #30 select = 1;
    #60 select = 0;
  join
  initial fork
    #2 reset_b = 1;
    #3 reset_b = 0;
    #4 reset_b = 1;
    D1 = 0;
    D2 = 1;
  join
endmodule

```

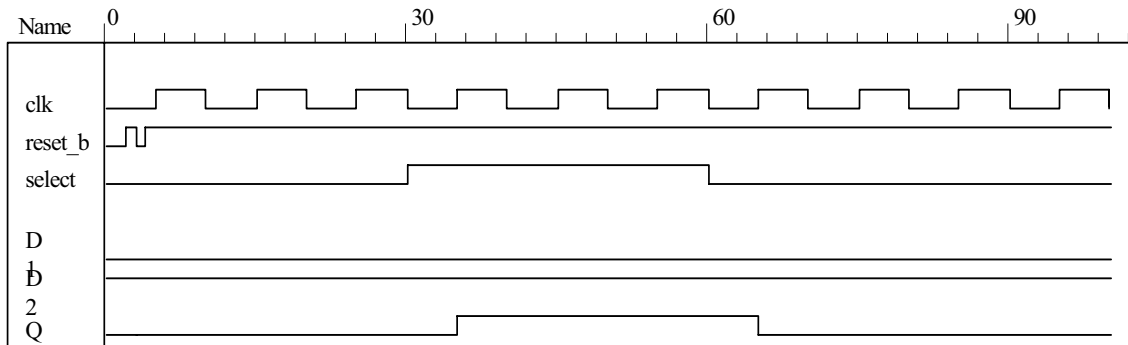

5.26 (a)

$$Q(t + 1) = JQ' + K'Q$$

When  $Q = 0$ ,  $Q(t + 1) = J$

When  $Q = 1$ ,  $Q(t + 1) = K'$

```

module JK_Behavior_a (output reg Q, input J, K, CLK, reset_b);
  always @ (posedge CLK, negedge reset_b)
    if (reset_b == 0) Q <= 0; else
      if (Q == 0) Q <= J;
      else Q <= ~K;
endmodule

```

(b)

```

module JK_Behavior_b (output reg Q, input J, K, CLK, reset_b);
  always @ (posedge CLK, negedge reset_b)
    if (reset_b == 0) Q <= 0;
    else
      case ({J, K})
        2'b00: Q <= Q;
        2'b01: Q <= 0;
        2'b10: Q <= 1;
        2'b11: Q <= ~Q;
      endcase
endmodule

```

```

module t_Prob_5_26 ();
  wire Q_a, Q_b;
  reg J, K, clk, reset_b;
  JK_Behavior_a M0 (Q_a, J, K, clk, reset_b);
  JK_Behavior_b M1 (Q_b, J, K, clk, reset_b);

  initial #100 $finish;
  initial begin clk = 0; forever #5 clk = ~clk; end
  initial fork
    #2 reset_b = 1;
    #3 reset_b = 0;           // Initialize to s0
    #4 reset_b = 1;
    J = 0; K = 0;
    #20 begin J = 1; K = 0; end
    #30 begin J = 1; K = 1; end
    #40 begin J = 0; K = 1; end
    #50 begin J = 1; K = 1; end
  join
endmodule

```

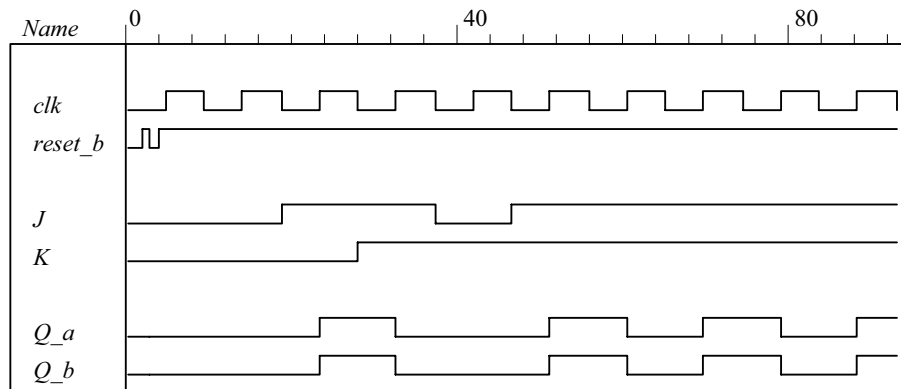

5.27

```

// Mealy FSM zero detector (See Fig. 5.16)
module Mealy_Zero_Detector (
  output reg y_out,
  input x_in, clock, reset
);
  reg [1: 0] state, next_state;
  parameter S0 = 2'b00, S1 = 2'b01, S2 = 2'b10, S3 = 2'b11;

  always @ (posedge clock, negedge reset) // state transition
    if (reset == 0) state <= S0;
    else state <= next_state;

```

```

always @ (state, x_in) // Form the next state
case (state)
  S0:begin y_out = 0; if (x_in) next_state = S1; else next_state = S0; end
  S1: begin y_out = ~x_in; if (x_in) next_state = S3; else next_state = S0; end
  S2:begin y_out = ~x_in; if (~x_in) next_state = S0; else next_state = S2; end
  S3: begin y_out = ~x_in; if (x_in) next_state = S2; else next_state = S0; end
endcase

endmodule

module t_Mealy_Zero_Detector;
  wire t_y_out;
  reg t_x_in, t_clock, t_reset;

  Mealy_Zero_Detector M0 (t_y_out, t_x_in, t_clock, t_reset);

  initial #200 $finish;
  initial begin t_clock = 0; forever #5 t_clock = ~t_clock; end

  initial fork
    t_reset = 0;
    #2 t_reset = 1;
    #87 t_reset = 0;
    #89 t_reset = 1;
    #10 t_x_in = 1;
    #30 t_x_in = 0;
    #40 t_x_in = 1;
    #50 t_x_in = 0;
    #52 t_x_in = 1;
    #54 t_x_in = 0;
    #70 t_x_in = 1;
    #80 t_x_in = 1;
    #70 t_x_in = 0;
    #90 t_x_in = 1;
    #100 t_x_in = 0;
    #120 t_x_in = 1;
    #160 t_x_in = 0;
    #170 t_x_in = 1;
  join
endmodule

```

Note: Simulation results match Fig. 5.22.

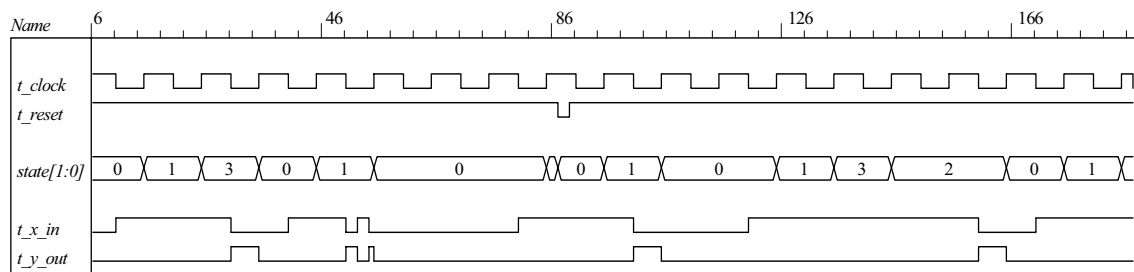

5.28 (a)

```

module Prob_5_28a (output A, input x, y, clk, reset_b);
  parameter s0 = 0, s1 = 1;
  reg state, next_state;
  assign A = state;

  always @ (posedge clk, negedge reset_b)
    if (reset_b == 0) state <= s0; else state <= next_state;

  always @ (state, x, y) begin
    next_state = s0;
    case (state)
      s0: case ({x, y})
          2'b00, 2'b11: next_state = s0;
          2'b01, 2'b10: next_state = s1;
        endcase
      s1: case ({x, y})
          2'b00, 2'b11: next_state = s1;
          2'b01, 2'b10: next_state = s0;
        endcase
    endcase
  end
endmodule

module t_Prob_5_28a ();
  wire A;
  reg x, y, clk, reset_b;
  Prob_5_28a M0 (A, x, y, clk, reset_b);
  initial #350 $finish;
  initial begin clk = 0; forever #5 clk = ~clk; end
  initial fork
    #2 reset_b = 1;
    #3 reset_b = 0; // Initialize to s0
    #4 reset_b = 1;
    x = 0; y = 0;
    #20 begin x = 1; y = 1; end
    #30 begin x = 0; y = 0; end
    #40 begin x = 1; y = 0; end
    #50 begin x = 0; y = 0; end
    #60 begin x = 1; y = 1; end
    #70 begin x = 1; y = 0; end
    #80 begin x = 0; y = 1; end
  join
endmodule

```

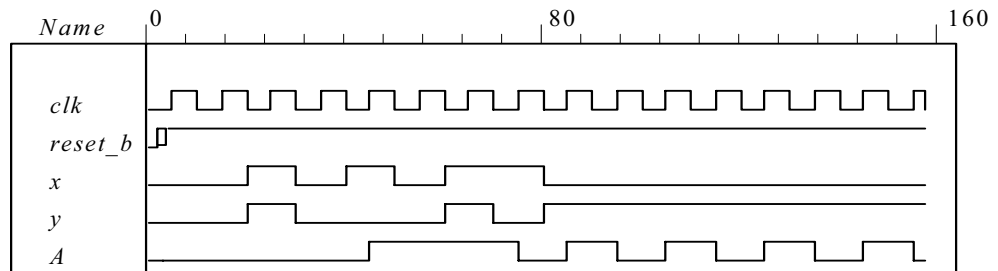

(b)

```

module Prob_5_28b (output A, input x, y, Clock, reset_b);
  xor (w1, x, y);
  xor (w2, w1, A);
  DFF M0 (A, w2, Clock, reset_b);
endmodule

```

```

module DFF (output reg Q, input D, Clock, reset_b);
  always @ (posedge Clock, negedge reset_b)
    if (reset_b == 0) Q <= 0;
    else Q <= D;
endmodule

```

```

module t_Prob_5_28b ();
  wire A;
  reg x, y, clk, reset_b;
  Prob_5_28b M0 (A, x, y, clk, reset_b);
  initial #350 $finish;
  initial begin clk = 0; forever #5 clk = ~clk; end
  initial fork
    #2 reset_b = 1;
    #3 reset_b = 0;           // Initialize to s0
    #4 reset_b = 1;
    x = 0; y = 0;
    #20 begin x = 1; y = 1; end
    #30 begin x = 0; y = 0; end
    #40 begin x = 1; y = 0; end
    #50 begin x = 0; y = 0; end
    #60 begin x = 1; y = 1; end
    #70 begin x = 1; y = 0; end
    #80 begin x = 0; y = 1; end
  join
endmodule

```

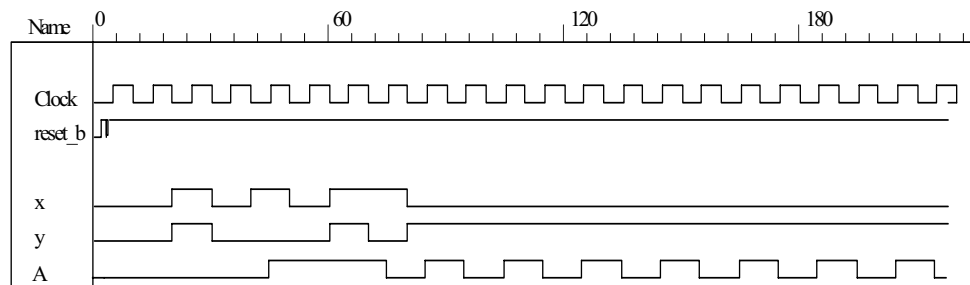

```
(c) See results of (b) and (c).
module t_Prob_5_28c ();
wire A_a, A_b;
reg x, y, clk, reset_b;
Prob_5_28a M0 (A_a, x, y, clk, reset_b);
Prob_5_28b M1 (A_b, x, y, clk, reset_b);

initial #350 $finish;
initial begin clk = 0; forever #5 clk = ~clk; end
initial fork
  #2 reset_b = 1;
  #3 reset_b = 0; // Initialize to s0
  #4 reset_b = 1;
  x = 0; y = 0;
  #20 begin x = 1; y = 1; end
  #30 begin x = 0; y = 0; end
  #40 begin x = 1; y = 0; end
  #50 begin x = 0; y = 0; end
  #60 begin x = 1; y = 1; end
  #70 begin x = 1; y = 0; end
  #80 begin x = 0; y = 1; end
join
endmodule
```

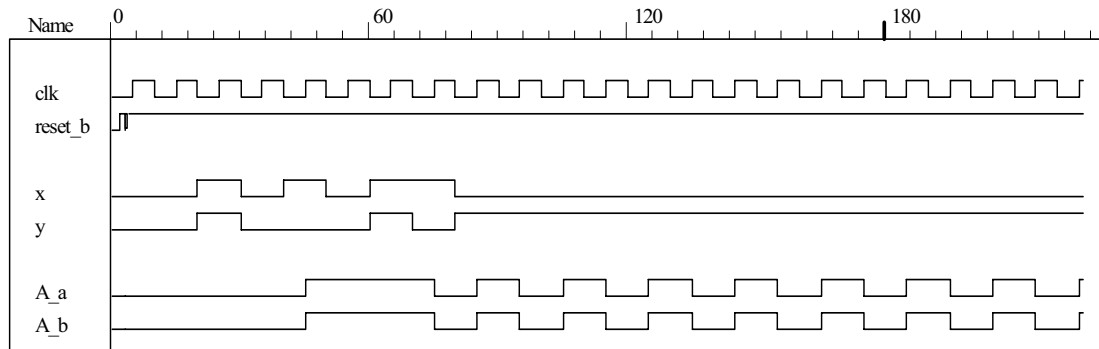

5.29

```
module Prob_5_29 (output reg y_out, input x_in, clock, reset_b);
parameter s0 = 3'b000, s1 = 3'b001, s2 = 3'b010, s3 = 3'b011, s4 = 3'b100;
reg [2: 0] state, next_state;

always @ (posedge clock, negedge reset_b)
if (reset_b == 0) state <= s0;
else state <= next_state;

always @ (state, x_in) begin
  y_out = 0;
  next_state = s0;
  case (state)
    s0: if (x_in) begin next_state = s4; y_out = 1; end else begin next_state = s3; y_out = 0; end
    s1: if (x_in) begin next_state = s4; y_out = 1; end else begin next_state = s1; y_out = 0; end
    s2: if (x_in) begin next_state = s0; y_out = 1; end else begin next_state = s2; y_out = 0; end
    s3: if (x_in) begin next_state = s2; y_out = 1; end else begin next_state = s1; y_out = 0; end
    s4: if (x_in) begin next_state = s3; y_out = 0; end else begin next_state = s2; y_out = 0; end
  default: next_state = 3'bxxx;
  endcase
end
endmodule
```

```

module t_Prob_5_29 ();
  wire y_out;
  reg x_in, clk, reset_b;

  Prob_5_29 M0 (y_out, x_in, clk, reset_b);

  initial #350$finish;
  initial begin clk = 0; forever #5 clk = ~clk; end
  initial fork
    #2 reset_b = 1;
    #3 reset_b = 0; // Initialize to s0
    #4 reset_b = 1;
    // Trace the state diagram and monitor y_out
    x_in = 0; // Drive from s0 to s3 to S1 and park
    #40 x_in = 1; // Drive to s4 to s3 to s2 to s0 to s4 and loop
    #90 x_in = 0; // Drive from s0 to s3 to s2 and part
    #110 x_in = 1; // Drive s0 to s4 etc
  join
endmodule

```

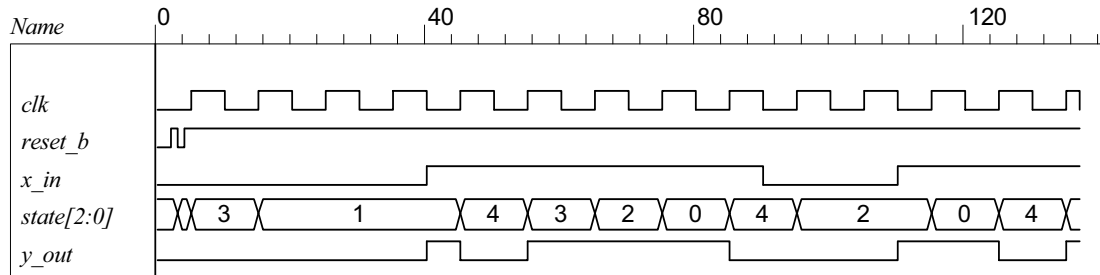



5.30

With non-blocking ( $\leq$ ) assignment operator:

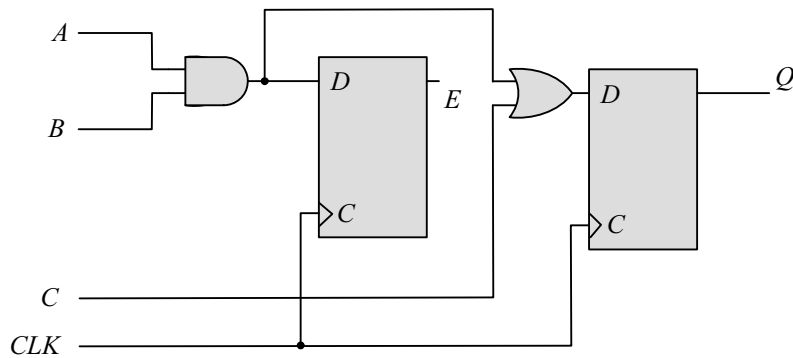

With blocking ( $=$ ) assignment operator:

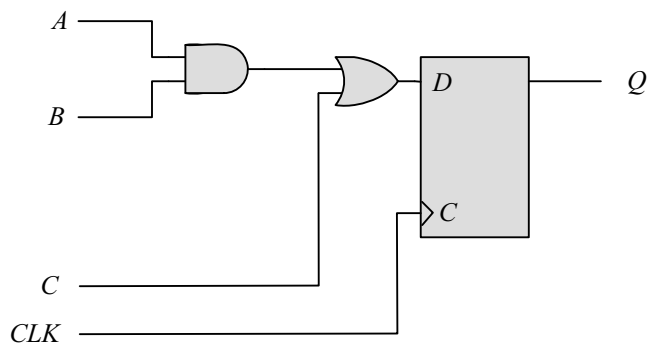

Note: The expression substitution implied by the sequential ordering with the blocking assignment operator results in the elimination of E by a synthesis tool. To retain E, it is necessary to declare E to be an output port of the module.

5.31

```
module Seq_Ckt (input A, B, C, CLK, output reg Q);
  reg E;
  always @ (posedge CLK)
  begin
    Q = E | C;
    E = A & B;
  end
endmodule
```

Note: The statements must be written in an order than produces the effect of concurrent assignments.

5.32

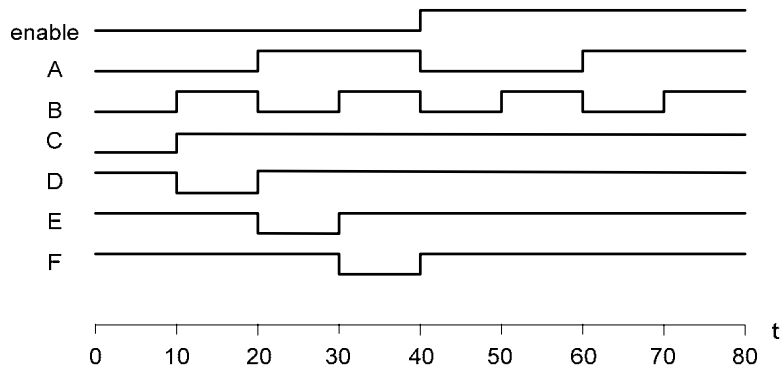

**initial begin**

```
enable = 0; A = 0; B = 0; C = 0; D = 1; E = 1; F = 1;
# 10 B = 1;
    C = 1;
    D = 0;
#10  A = 1;
    B = 0;
    D = 1;
    E = 0;
#10  B = 1;
    E = 1;
    F = 0;
#10  enable = 1;
    A = 0;
    B = 0;
    F = 0;
#10  B = 1;
#10  A = 1;
    B = 0;
#10  B = 1;
end
```

**initial fork**

```
enable = 0; A = 0; B = 0; C = 0; D = 1; E = 1; F = 1;
#40 enable = 1;
#20 A = 1;
#40 A = 0;
#60 A = 1;
#10 B = 1;
#20 B = 0;
#30 B = 1;
#40 B = 0;
#50 B = 1;
#60 B = 0;
#70 B = 1;
#10 C = 1;
#10 D = 0;
#20 D = 1;
#20 E = 0;
#30 E = 1;
#30 F = 0;
#40 F = 1;
```

**join**

- 5.33 Signal transitions that are caused by input signals that change on the active edge of the clock race with the clock itself to reach the affected flip-flops, and the outcome is indeterminate (unpredictable). Conversely, changes caused by inputs that are synchronized to the inactive edge of the clock reach stability before the active edge, with predictable outputs of the flip-flops that are affected by the inputs.

5.34

```

module JK_flop_Prob_5_34 (output Q, input J, K, clk);
  wire K_bar;
  D_flop M0 (Q, D, clk);
  Mux M1 (D, J, K_bar, Q);
  Inverter M2 (K_bar, K);
endmodule

```

```

module D_flop (output reg Q, input D, clk);
  always @ (posedge clk) Q <= D;
endmodule

```

```

module Inverter (output y_bar, input y);
  assign y_bar = ~y;
endmodule

```

```

module Mux (output y, input a, b, select);
  assign y = select ? a : b;
endmodule

```

```

module t_JK_flop_Prob_5_34 ();
  wire Q;
  reg J, K, clock;
  JK_flop_Prob_5_34 M0 (Q, J, K, clock);
  initial #500 $finish;
  initial begin clock = 0; forever #5 clock = ~clock; end
  initial fork
  #10 begin J = 0; K = 0; end // toggle Q unknown
  #20 begin J = 0; K = 1; end // set Q to 0
  #30 begin J = 1; K = 0; end // set q to 1
  #40 begin J = 1; K = 1; end // no change
  #60 begin J = 0; K = 0; end // toggle Q
  join
endmodule

```

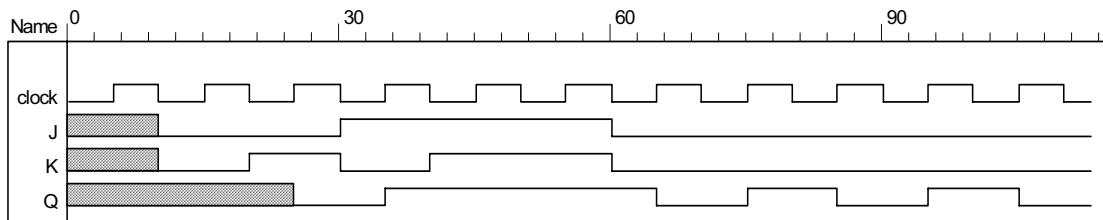

5.35

```

initial begin
  enable = 0; A = 0; B = 0; C = 0; D = 1; E = 1; F = 1;
  #10 begin B = 1; C = 1; D = 0; end
  #10 begin A = 1; B = 0; D = 1; E = 0; end
  #10 begin A = 1; B = 0; E = 1; F = 0; end
  #10 begin enable = 1; A = 0; B = 0; F = 1; end
  #10 begin B = 1; end
  #10 begin A = 1; B = 0; end
  #10 B = 1;
end

```

```
initial fork
  enable = 0;
  #40 enable = 1;
  #20 A = 1;
  #40 A = 0;
  #60 A = 1;

  #10 B = 1;
  #20 B = 0;
  #30 B = 1;
  #40 B = 0;
  #50 B = 1;
  #60 B = 0;
  #70 B = 1;

  #10 C = 1;

  #10 D = 0;
  #20 D = 1;

  #20 E = 0;
  #30 E = 1;

  #30 F = 0;
  #40 F = 1;
join
```

5.36

Note: See Problem 5.8 (counter with repeated sequence: (A, B) = 00, 01, 10, 00 ...

```
// See Fig. P5.8
module Problem_5_36 (output A, B, input Clock, reset_b);
  or (T_A, A, B);
  or (T_B, A_b, B);
  T_flop M0 (A, A_b, T_A, Clock, reset_b);
  T_flop M1 (B, B_b, T_B, Clock, reset_b);
endmodule

module T_flop (output reg Q, output QB, input T, Clock, reset_b);
  assign QB = ~ Q;
  always @ (posedge Clock, negedge reset_b)
    if (reset_b == 0) Q <= 0;
    else if (T) Q <= ~Q;
endmodule

module t_Problem_5_36 ();
  wire A, B;
  reg Clock, reset_b;

  Problem_5_36 M0 (A, B, Clock, reset_b);

  initial #350$finish;
  initial begin Clock = 0; forever #5 Clock = ~Clock; end
  initial fork
    #2 reset_b = 1;
    #3 reset_b = 0;
    #4 reset_b = 1;
  join
endmodule
```

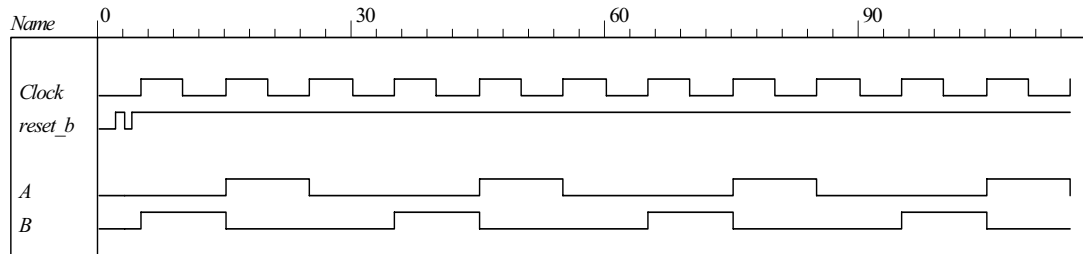

5.37

```

module Problem_5_37_Fig_5_25 (output reg y, input x_in, clock, reset_b);

  parameter a = 3'b000, b = 3'b001, c = 3'b010, d = 3'b011, e = 3'b100, f = 3'b101, g = 3'b110;
  reg [2: 0] state, next_state;

  always @ (posedge clock, negedge reset_b)
    if (reset_b == 0) state <= a;
    else state <= next_state;

  always @ (state, x_in) begin
    y = 0;
    next_state = a;
    case (state)
      a:   begin y = 0; if (x_in == 0) next_state = a; else next_state = b; end

      b:   begin y = 0; if (x_in == 0) next_state = c; else next_state = d; end

      c:   begin y = 0; if (x_in == 0) next_state = a; else next_state = d; end

      d:   if (x_in == 0) begin y = 0; next_state = e; end
          else begin y = 1; next_state = f; end

      e:   if (x_in == 0) begin y = 0; next_state = a; end
          else begin y = 1; next_state = f; end

      f:   if (x_in == 0) begin y = 0; next_state = g; end
          else begin y = 1; next_state = f; end

      g:   if (x_in == 0) begin y = 0; next_state = a; end
          else begin y = 1; next_state = f; end

    default: next_state = a;
  endcase
end
endmodule

module Problem_5_37_Fig_5_26 (output reg y, input x_in, clock, reset_b);
  parameter a = 3'b000, b = 3'b001, c = 3'b010, d = 3'b011, e = 3'b100;
  reg [2: 0] state, next_state;

  always @ (posedge clock, negedge reset_b)
    if (reset_b == 0) state <= a;
    else state <= next_state;

```

```
always @ (state, x_in) begin
  y = 0;
  next_state = a;
  case (state)
    a:   begin y = 0; if (x_in == 0) next_state = a; else next_state = b; end

    b:   begin y = 0; if (x_in == 0) next_state = c; else next_state = d; end

    c:   begin y = 0; if (x_in == 0) next_state = a; else next_state = d; end

    d:   if (x_in == 0) begin y = 0; next_state = e; end
        else begin y = 1; next_state = d; end

    e:   if (x_in == 0) begin y = 0; next_state = a; end
        else begin y = 1; next_state = d; end

  default: next_state = a;
  endcase
end
endmodule
```

```
module t_Problem_5_37 ();
  wire y_Fig_5_25, y_Fig_5_26;
  reg x_in, clock, reset_b;

  Problem_5_37_Fig_5_25 M0 (y_Fig_5_25, x_in, clock, reset_b);
  Problem_5_37_Fig_5_26 M1 (y_Fig_5_26, x_in, clock, reset_b);

  wire [2: 0] state_25 = M0.state;
  wire [2: 0] state_26 = M1.state;

  initial #350 $finish;
  initial begin clock = 0; forever #5 clock = ~clock; end
  initial fork
    x_in = 0;
    #2 reset_b = 1;
    #3 reset_b = 0;
    #4 reset_b = 1;
    #20 x_in = 1;
    #40 x_in = 0; // abdea, abdea

    #60 x_in = 1;
    #100 x_in = 0; // abdf....fga, abd ... dea

    #120 x_in = 1;
    #160 x_in = 0;
    #170 x_in = 1;
    #200 x_in = 0; // abdf....fgf...fga, abd ...ded...ea

    #220 x_in = 1;
    #240 x_in = 0;
    #250 x_in = 1; // abdef... // abded...
  join
endmodule
```

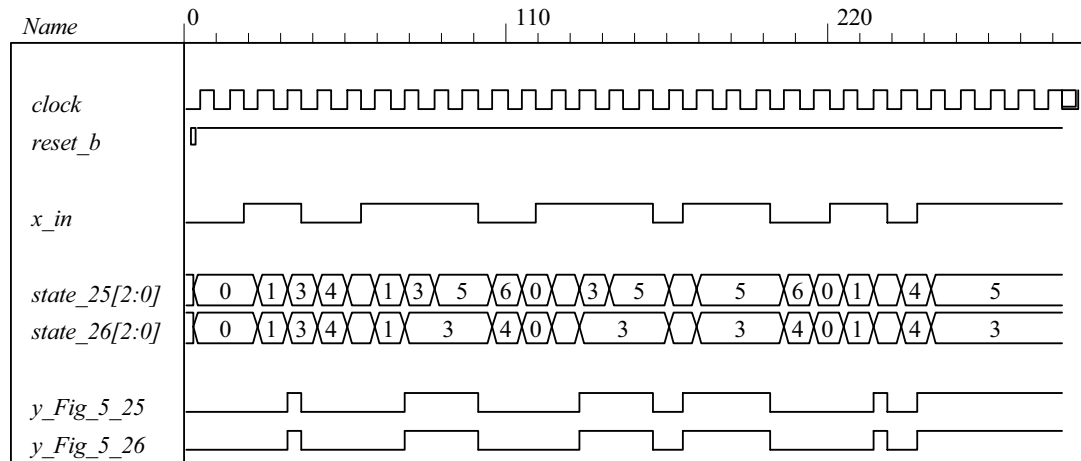

5.38 (a)

```

module Prob_5_38a (input x_in, clock, reset_b);
parameter s0 = 2'b00, s1 = 2'b01, s2 = 2'b10, s3 = 2'b11;
reg [1: 0] state, next_state;

always @ (posedge clock, negedge reset_b)
if (reset_b == 0) state <= s0;
else state <= next_state;

always @ (state, x_in) begin
    next_state = s0;
    case (state)
    s0: if (x_in == 0) next_state = s0;
        else if (x_in == 1) next_state = s3;

    s1: if (x_in == 0) next_state = s1;
        else if (x_in == 1) next_state = s2;

    s2: if (x_in == 0) next_state = s2;
        else if (x_in == 1) next_state = s0;

    s3: if (x_in == 0) next_state = s3;
        else if (x_in == 1) next_state = s1;
    default: next_state = s0;
    endcase
end
endmodule
    
```

```

module t_Prob_5_38a ();
  reg x_in, clk, reset_b;

  Prob_5_38a M0 ( x_in, clk, reset_b);

  initial #350$finish;
  initial begin clk = 0; forever #5 clk = ~clk; end
  initial fork
    #2 reset_b = 1;
    #3 reset_b = 0;    // Initialize to s0
    #4 reset_b = 1;
    #2 x_in = 0;
    #20 x_in = 1;
    #60 x_in = 0;
    #80 x_in = 1;
    #90 x_in = 0;
    #110 x_in = 1;
    #120 x_in = 0;
    #140 x_in = 1;
    #150 x_in = 0;
    #170 x_in = 1;
  join
endmodule

```

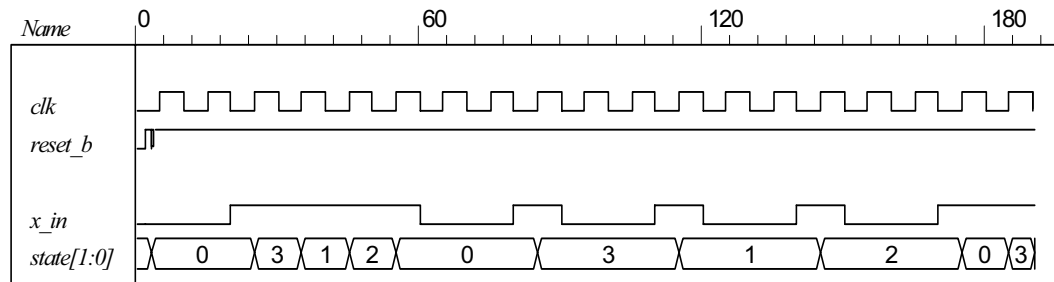

(b)

```

module Prob_5_38b (input x_in, clock, reset_b);
  parameter s0 = 2'b00, s1 = 2'b01, s2 = 2'b10, s3 = 2'b11;
  reg [1: 0] state, next_state;

  always @ (posedge clock, negedge reset_b)
    if (reset_b == 0) state <= s0;
    else state <= next_state;

  always @ (state, x_in) begin
    next_state = s0;
    case (state)
      s0:   if (x_in == 0) next_state = s0;
           else if (x_in == 1) next_state = s3;

      s1:   if (x_in == 0) next_state = s1;
           else if (x_in == 1) next_state = s2;

      s2:   if (x_in == 0) next_state = s2;
           else if (x_in == 1) next_state = s0;

      s3:   if (x_in == 0) next_state = s3;
           else if (x_in == 1) next_state = s1;
    default:   next_state = s0;
    endcase
  end

```



```

endmodule

module t_Prob_5_38b ();

    reg x_in, clk, reset_b;

    Prob_5_38b M0 ( x_in, clk, reset_b);

    initial #350$finish;
    initial begin clk = 0; forever #5 clk = ~clk; end
    initial fork
        #2 reset_b = 1;
        #3 reset_b = 0;    // Initialize to s0
        #4 reset_b = 1;
        #2 x_in = 0;
        #20 x_in = 1;
        #60 x_in = 0;
        #80 x_in = 1;
        #90 x_in = 0;
        #110 x_in = 1;
        #120 x_in = 0;
        #140 x_in = 1;
        #150 x_in = 0;
        #170 x_in = 1;
    join
endmodule

```

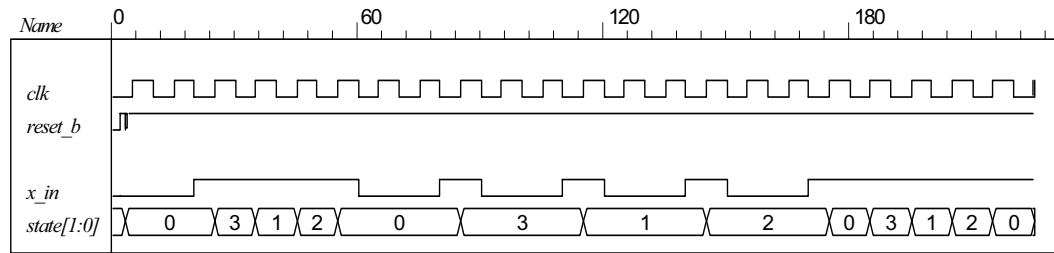

5.39

```

module Serial_2s_Comp (output reg B_out, input B_in, clk, reset_b);
// See problem 5.17
    parameter S_0 = 1'b0, S_1 = 1'b1;
    reg state, next_state;
    always @ (posedge clk, negedge reset_b) begin
        if (reset_b == 0) state <= S_0;
        else state <= next_state;
    end

    always @ (state, B_in) begin
        B_out = 0;
        case (state)
            S_0: if (B_in == 0) begin next_state = S_0; B_out = 0; end
                else if (B_in == 1) begin next_state = S_1; B_out = 1; end

            S_1: begin next_state = S_1; B_out = ~B_in; end
        default: next_state = S_0;

    endcase
    end
endmodule

```

```

module t_Serial_2s_Comp ();
  wire B_in, B_out;
  reg clk, reset_b;
  reg [15: 0] data;
  assign B_in = data[0];

  always @ (negedge clk, negedge reset_b)
    if (reset_b == 0) data <= 16'ha5ac; else data <= data >> 1; // Sample bit stream

  Serial_2s_Comp M0 (B_out, B_in, clk, reset_b);

  initial #150 $finish;
  initial begin clk = 0; forever #5 clk = ~clk; end
  initial fork
    #10 reset_b = 0;
    #12 reset_b = 1;
  join
endmodule

```

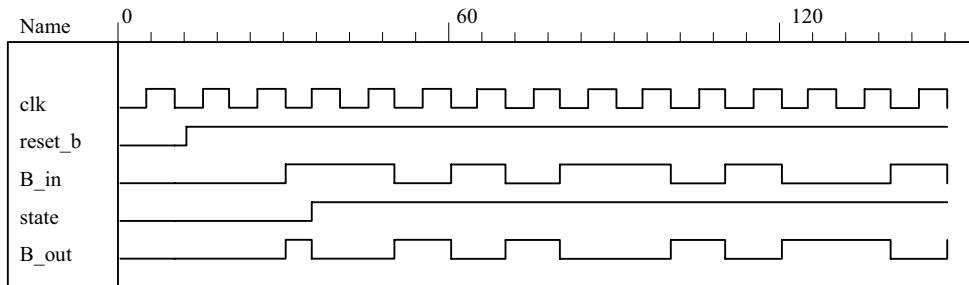

5.40

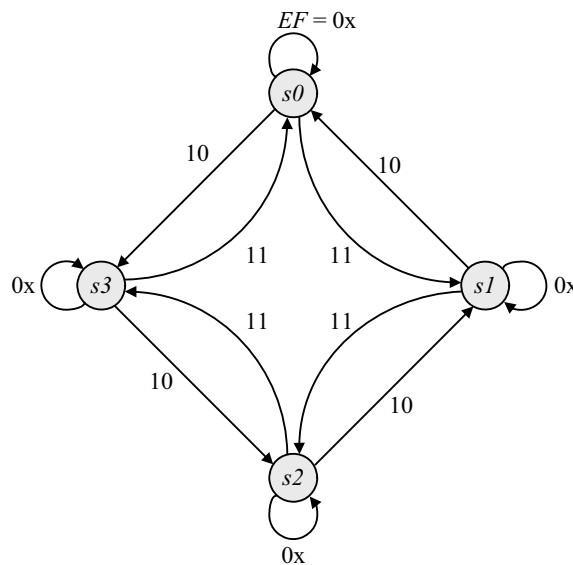

```

module Prob_5_40 (input E, F, clock, reset_b);
  parameter s0 = 2'b00, s1 = 2'b01, s2 = 2'b10, s3 = 2'b11;
  reg [1: 0] state, next_state;

  always @ (posedge clock, negedge reset_b)
    if (reset_b == 0) state <= s0;
    else state <= next_state;

```

```

always @ (state, E, F) begin
  next_state = s0;
  case (state)
    s0:   if (E == 0) next_state = s0;
         else if (F == 1) next_state = s1; else next_state = s3;

    s1:   if (E == 0) next_state = s1;
         else if (F == 1) next_state = s2; else next_state = s0;

    s2:   if (E == 0) next_state = s2;
         else if (F == 1) next_state = s3; else next_state = s1;

    s3:   if (E == 0) next_state = s3;
         else if (F == 1) next_state = s0; else next_state = s2;
    default: next_state = s0;
  endcase
end
endmodule

```

```

module t_Prob_5_40 ();

  reg E, F, clk, reset_b;

  Prob_5_40 M0 ( E, F, clk, reset_b);

  initial #350$finish;
  initial begin clk = 0; forever #5 clk = ~clk; end
  initial fork
    #2 reset_b = 1;
    #3 reset_b = 0; // Initialize to s0
    #4 reset_b = 1;
    #2 E = 0;
    #20 begin E = 1; F = 1; end
    #60 E = 0;
    #80 E = 1;
    #90 E = 0;
    #110 E = 1;
    #120 E = 0;
    #140 E = 1;
    #150 E = 0;
    #170 E = 1;
    #170 F = 0;
  join
endmodule

```

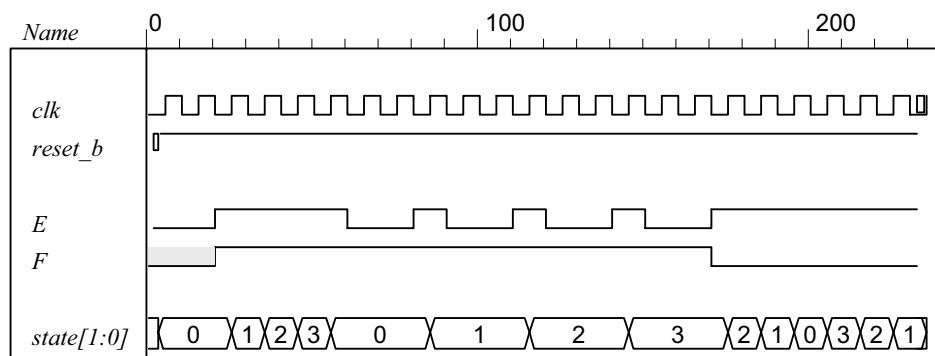

5.41

```

module Prob_5_41 (output reg y_out, input x_in, clock, reset_b);
parameter s0 = 3'b000, s1 = 3'b001, s2 = 3'b010, s3 = 3'b011, s4 = 3'b100;
reg [2: 0] state, next_state;

always @ (posedge clock, negedge reset_b)
if (reset_b == 0) state <= s0;
else state <= next_state;

always @ (state, x_in) begin
y_out = 0;
next_state = s0;
case (state)
s0: if (x_in) begin next_state = s4; y_out = 1; end else begin next_state = s3; y_out = 0; end
s1: if (x_in) begin next_state = s4; y_out = 1; end else begin next_state = s1; y_out = 0; end
s2: if (x_in) begin next_state = s0; y_out = 1; end else begin next_state = s2; y_out = 0; end
s3: if (x_in) begin next_state = s2; y_out = 1; end else begin next_state = s1; y_out = 0; end
s4: if (x_in) begin next_state = s3; y_out = 0; end else begin next_state = s2; y_out = 0; end
default: next_state = 3'bxxx;
endcase
end
endmodule

```

```

module t_Prob_5_41 ();
wire y_out;
reg x_in, clk, reset_b;

Prob_5_41 M0 (y_out, x_in, clk, reset_b);

initial #350$finish;
initial begin clk = 0; forever #5 clk = ~clk; end
initial fork
#2 reset_b = 1;
#3 reset_b = 0; // Initialize to s0
#4 reset_b = 1;
// Trace the state diagram and monitor y_out
x_in = 0; // Drive from s0 to s3 to S1 and park
#40 x_in = 1; // Drive to s4 to s3 to s2 to s0 to s4 and loop
#90 x_in = 0; // Drive from s0 to s3 to s2 and part
#110 x_in = 1; // Drive s0 to s4 etc
join
endmodule

```

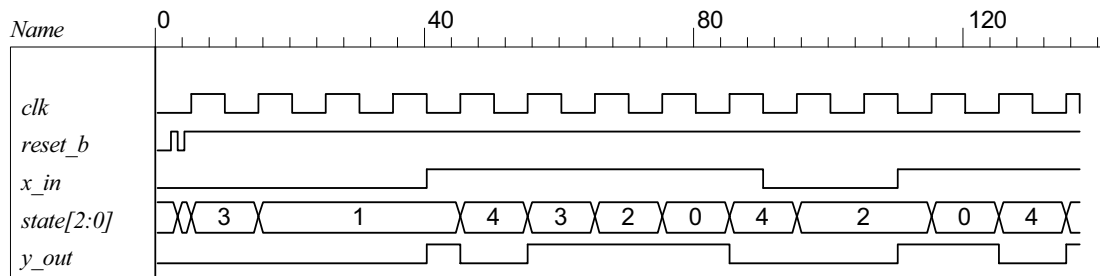

5.42

```
module Prob_5_42 (output A, B, B_bar, y, input x, clk, reset_b);
// See Fig. 5.29
  wire w1, w2, w3, D1, D2;
  and (w1, A, x);
  and (w2, B, x);
  or (D_A, w1, w2);

  and (w3, B_bar, x);
  and (y, A, B);
  or (D_B, w1, w3);
  DFF M0_A (A, D_A, clk, reset_b);
  DFF M0_B (B, D_B, clk, reset_b);
  not (B_bar, B);
endmodule

module DFF (output reg Q, input data, clk, reset_b);
  always @ (posedge clk, negedge reset_b)
  if (reset_b == 0) Q <= 0; else Q <= data;
endmodule

module t_Prob_5_42 ();
  wire A, B, B_bar, y;
  reg bit_in, clk, reset_b;
  wire [1:0] state;
  assign state = {A, B};
  wire detect = y;

  Prob_5_42 M0 (A, B, B_bar, y, bit_in, clk, reset_b);

  // Patterns from Problem 5.45.

  initial #350$finish;
  initial begin clk = 0; forever #5 clk = ~clk; end
  initial fork
    #2 reset_b = 1;
    #3 reset_b = 0;
    #4 reset_b = 1;
    // Trace the state diagram and monitor detect (assert in S3)
    bit_in = 0; // Park in S0
    #20 bit_in = 1; // Drive to S0
    #30 bit_in = 0; // Drive to S1 and back to S0 (2 clocks)
    #50 bit_in = 1;
    #70 bit_in = 0; // Drive to S2 and back to S0 (3 clocks)
    #80 bit_in = 1;
    #130 bit_in = 0; // Drive to S3, park, then and back to S0
  join
endmodule
```

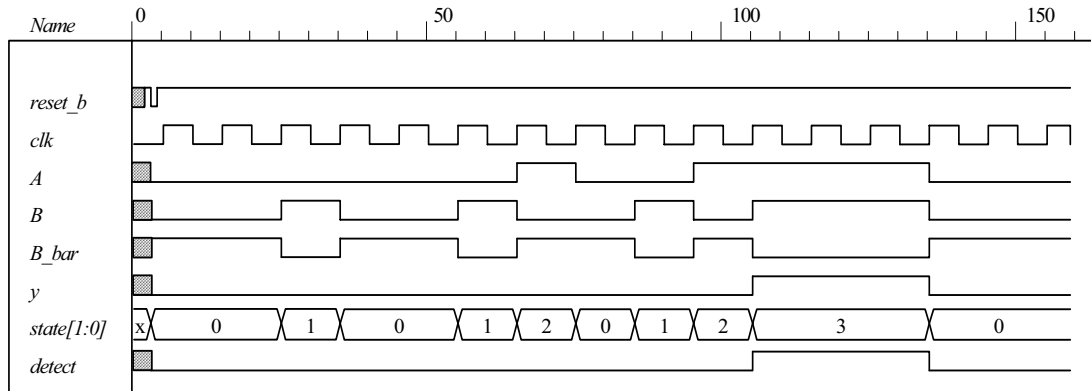

5.43

```

module Binary_Counter_3_bit (output [2: 0] count, input clk, reset_b)
always @ (posedge clk) if (reset_b == 0) count <= 0; else count <= next_count;
always @ (count) begin
  case (state)
    3'b000: count = 3'b001;
    3'b001: count = 3'b010;
    3'b010: count = 3'b011;
    3'b011: count = 3'b100;
    3'b100: count = 3'b001;
    3'b101: count = 3'b010;
    3'b110: count = 3'b011;
    3'b111: count = 3'b100;
    default: count = 3'b000;
  endcase
end
endmodule

```

```

module t_Binary_Counter_3_bit ()
wire [2: 0] count;
reg clk, reset_b;
  Binary_Counter_3_bit M0 ( count, clk, reset_b)

  initial #150 $finish;
  initial begin clk = 0; forever #5 clk = ~clk; end
  initial fork
    reset = 1;
    #10 reset = 0;
    #12 reset = 1;
  endfork
endmodule

```

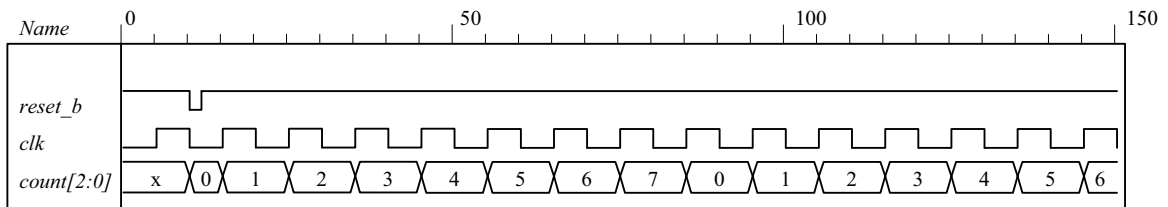

Alternative: structural model.

```

module Prob_5_41 (output A2, A1, A0, input T, clk, reset_bar);
  wire toggle_A2;

  T_flop M0 (A0, T, clk, reset_bar);
  T_flop M1 (A1, A0, clk, reset_bar);
  T_flop M2 (A2, toggle_A2, clk, reset_bar);
  and (toggle_A2, A0, A1);
endmodule

```

```

module T_flop (output reg Q, input T, clk, reset_bar);
  always @ (posedge clk, negedge reset_bar)
    if (!reset_bar) Q <= 0; else if (T) Q <= ~Q; else Q <= Q;
endmodule

```

```

module t_Prob_5_41;
  wire A2, A1, A0;
  wire [2: 0] count = {A2, A1, A0};
  reg T, clk, reset_bar;
  Prob_5_41 M0 (A2, A1, A0, T, clk, reset_bar);

  initial #200 $finish;
  initial begin clk = 0; forever #5 clk = ~clk; end
  initial fork reset_bar = 0; #2 reset_bar = 1; #40 reset_bar = 0; #42 reset_bar = 1; join
  initial fork T = 0; #20 T = 1; #70 T = 0; #110 T = 1; join
endmodule

```

If the input to *A0* is changed to 0 the counter counts incorrectly. It resumes a correct counting sequence when *T* is changed back to 1.

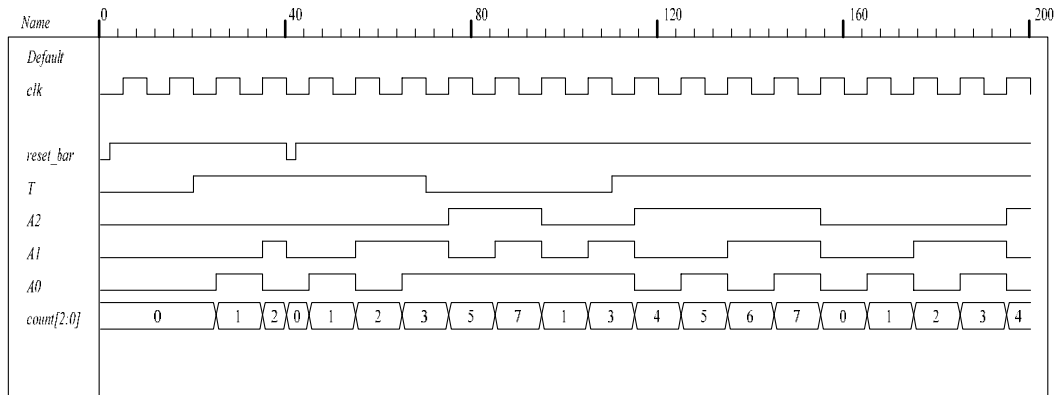

5.44

```

module DFF_synch_reset (output reg Q, input data, clk, reset);
  always @ (posedge clk)
  if (reset) Q <= 0; else Q <= data;
endmodule

```

```

module t_DFF_synch_reset ();
  reg data, clk, reset;
  wire Q;

```

```

  DFF_synch_reset M0 (Q, data, clk, reset);

```

```

initial #150 $finish;
initial begin clk = 0; forever #5 clk = ~clk; end
initial fork
  reset = 1;
  #20 reset = 1;
  #40 reset = 0;

  #10 data = 1;
  #50 data = 0;
  #60 data = 1;
  #100 data = 0;
join
endmodule

```

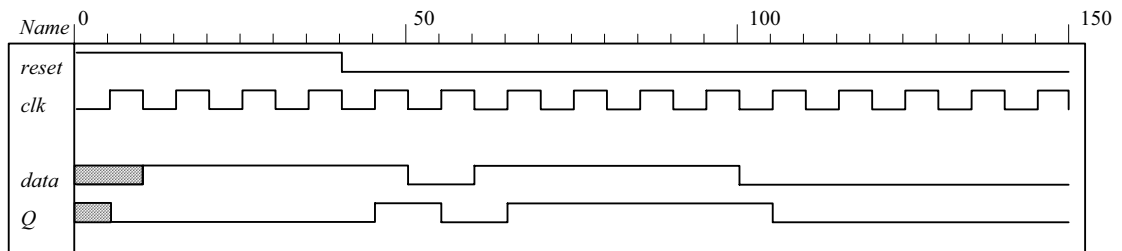

5.45

```

module Seq_Detector_Prob_5_45 (output detect, input bit_in, clk, reset_b);
  parameter S0 = 0, S1 = 1, S2 = 2, S3 = 3;
  reg [1: 0] state, next_state;

```

```

  assign detect = (state == S3);
  always @ (posedge clk, negedge reset_b)
  if (reset_b == 0) state <= S0; else state <= next_state;

```

```

  always @ (state, bit_in) begin
    next_state = S0;
    case (state)
      0: if (bit_in) next_state = S1; else state = S0;
      1: if (bit_in) next_state = S2; else next_state = S0;
      2: if (bit_in) next_state = S3; else state = S0;
      3: if (bit_in) next_state = S3; else next_state = S0;
    default: next_state = S0;
    endcase
  end
endmodule

```



```

module t_Seq_Detector_Prob_5_45 ();
  wire detect;
  reg bit_in, clk, reset_b;

  Seq_Detector_Prob_5_45 M0 (detect, bit_in, clk, reset_b);

  initial #350$finish;
  initial begin clk = 0; forever #5 clk = ~clk; end
  initial fork
    #2 reset_b = 1;
    #3 reset_b = 0;
    #4 reset_b = 1;
    bit_in = 0; // Trace the state diagram and monitor detect (assert in S3)
    // Park in S0
    #20 bit_in = 1; // Drive to S0
    #30 bit_in = 0; // Drive to S1 and back to S0 (2 clocks)
    #50 bit_in = 1;
    #70 bit_in = 0; // Drive to S2 and back to S0 (3 clocks)
    #80 bit_in = 1;
    #130 bit_in = 0; // Drive to S3, park, then and back to S0
  join
endmodule

```

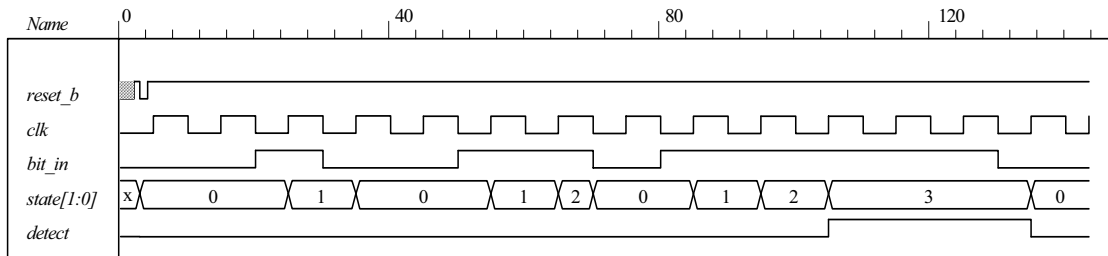

## CHAPTER 6

- 6.1** The structure shown below gates the clock through a nand gate. In practice, the circuit can exhibit two problems if the load signal is asynchronous: (1) the gated clock arrives in the setup interval of the clock of the flip-flop, causing metastability, and (2) the load signal truncates the width of the clock pulse. Additionally, the propagation delay through the nand gate might compromise the synchronicity of the overall circuit.

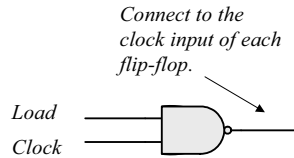

- 6.2** Modify Fig. 6.2, with each stage replicating the first stage shown below:

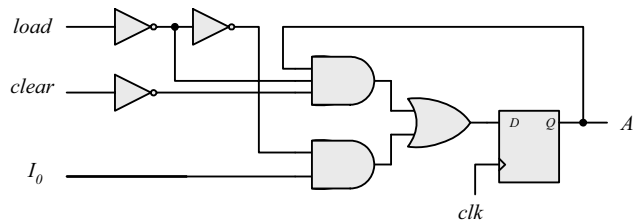

<i>Load</i>	<i>Clear</i>	<i>D</i>	<i>Operation</i>
0	0	$A_0$	No change
0	1	0	Clear to 0
1	x	$I_0$	Load input

Note: In this design, *load* has priority over *clear*.

- 6.3** Serial data is transferred one bit at a time. Parallel data is transferred n bits at a time ( $n > 1$ ).

A shift register can convert serial data into parallel data by first shifting one bit a time into the register and then taking the parallel data from the register outputs.

A shift register with parallel load can convert parallel data to a serial format by first loading the data in parallel and then shifting the bits one at a time.

- 6.4** 101101  $\Rightarrow$  1101; 0110; 1011; 1101; 0110; 1011

- 6.5** (a) See Fig. 11.19: IC 74194

(b) See Fig. 11.20. Connect two 74194 ICs to form an 8-bit register.

6.6 First stage of register:

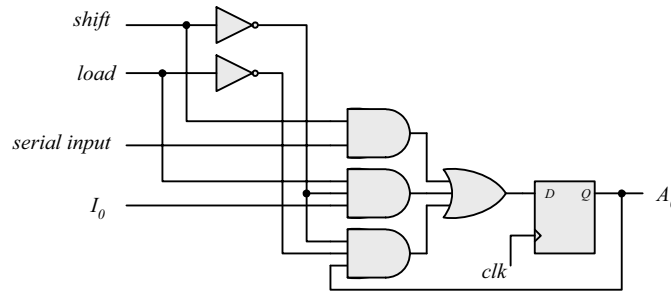

6.7 First stage of register:

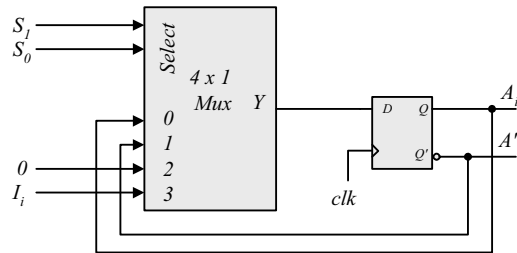

6.8  $A = 0010, 0001, 1000, 1100$ . Carry = 1, 1, 1, 0

6.9 (a) In Fig. 6.5, complement the serial output of shift register B (with an inverter), and set the initial value of the carry to 1.

(b)

Present state	Inputs		Next state	Output	FF inputs	
	Q	x y			Q	D
0	0	0	0	0	0	x
0	0	0	1	1	1	x
0	0	1	0	1	0	x
0	0	1	0	0	0	x
1	1	0	1	1	x	0
1	1	0	1	0	x	0
1	1	1	0	0	x	1
1	1	1	1	1	x	0

		x			
		00	01	11	10
Q	0	$m_0$	$m_1$ 1	$m_3$	$m_2$
	1	$m_4$ x	$m_5$ x	$m_7$ x	$m_6$ x

$J_Q = x'y$

		x			
		00	01	11	10
Q	0	$m_0$ x	$m_1$ x	$m_3$ x	$m_2$ x
	1	$m_4$	$m_5$	$m_7$	$m_6$ 1

$K_Q = xy' \oplus$   
 $D = Q \oplus x \oplus y$

- 6.10** See solution to Problem 5.7.  
 Note that  $y = x$  if  $Q = 0$ , and  $y = x'$  if  $Q = 1$ .  $Q$  is set on the first 1 from  $x$ .  
 Note that  $x \oplus 0 = x$ , and  $x \oplus 1 = x'$ .

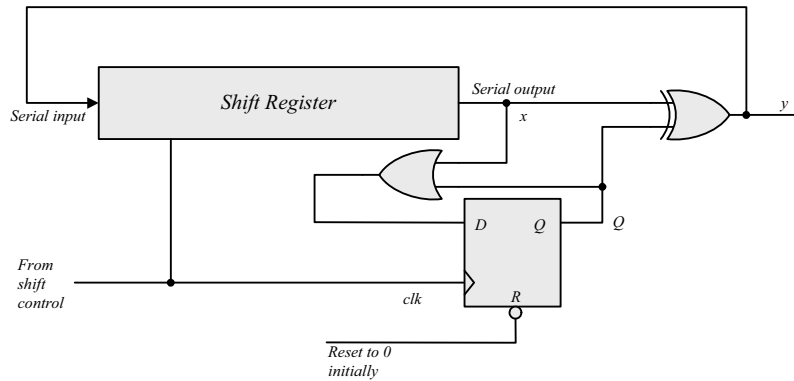

- 6.11** (a) A count down counter.  
 (b) A count up counter.
- 6.12** Similar to diagram of Fig. 6.8.  
 (a) With the bubbles in  $C$  removed (positive-edge).  
 (b) With complemented flip-flops connected to  $C$ .

**6.13**

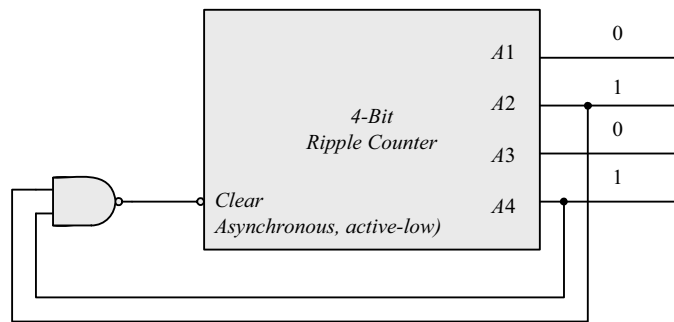

- 6.14** (a) 4; (b) 9; (c) 10
- 6.15** The worst case is when all 10 flip-flops are complemented. The maximum delay is  $10 \times 3\text{ns} = 30\text{ ns}$ .  
 The maximum frequency is  $10^9/30 = 33.3\text{ MHz}$

**6.16** Q8 Q4 Q2 Q1 : 1010      1100      1110    Self correcting  
 Next state:      1011      1101      1111  
 Next state:      0100      0100      0000

1010 → 1011 → 0100  
 1100 → 1101 → 0100  
 1110 → 1111 → 0000

**6.17** With  $E$  denoting the count enable in Fig. 6.12 and D-flip-flops replacing the J-K flip-flops, the toggling action of the bits of the counter is determined by:  $T_0 = E$ ,  $T_1 = A_0E$ ,  $T_2 = A_0A_1E$ ,  $T_3 = A_0A_1A_2E$ . Since  $D_A = A \oplus T_A$  the inputs of the flip-flops of the counter are determined by:  $D_{A0} = A_0 \oplus E$ ;  $D_{A1} = A_1 \oplus (A_0E)$ ;  $D_{A2} = A_2 \oplus (A_0A_1E)$ ;  $D_{A3} = A_3 \oplus (A_0A_1A_2E)$ .

**6.18** When  $up = down = 1$  the circuit counts up.

	$up$	$down$	$x$	$y$	Operation
	0	0	0	0	No change
	0	1	0	0	Count down
	1	0	1	0	Count up
	1	1	0	0	No change



Add this to Fig. 6.13

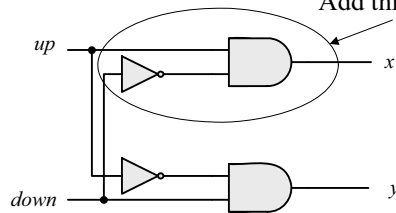

$$x = up (down)'$$

$$y = (up)'down$$

**6.19 (b)** From the state table in Table 6.5:

$$D_{Q1} = Q_1'$$

$$D_{Q2} = \sum (1, 2, 5, 6)$$

$$D_{Q4} = \sum (3, 4, 5, 6)$$

$$D_{Q8} = \sum (7, 8)$$

$$\text{Don't care: } d = \sum (10, 11, 12, 13, 14, 15)$$

Simplifying with maps:

$$D_{Q2} = Q_2Q_1' + Q_8Q_2'Q_1$$

$$D_{Q4} = Q_4Q_1' + Q_4Q_2' + Q_4Q_2Q_1$$

$$D_{Q8} = Q_8Q_1' + Q_4Q_2Q_1$$

(a)

Present state	Next state	Flip-flop inputs			
$A_8 A_4 A_2 A_1$	$A_8 A_4 A_2 A_1$	$J_{A8} K_{A8}$	$J_{A4} K_{A4}$	$J_{A2} K_{A2}$	$J_{A1} K_{A1}$
0000	0001	0 x	0 x	0 x	1 x
0001	0010	0 x	0 x	1 x	x 1
0010	0011	0 x	0 x	x 0	1 x
0011	0100	0 x	1 x	x 1	x 1
0100	0101	0 x	x 0	0 x	1 x
0101	0110	0 x	x 0	1 x	x 1
0110	0111	0 x	x 0	x 0	1 x
0111	1000	1 x	x 1	x 1	x 1
1000	1001	x 0	0 x	0 x	1 x
1001	0000	x 1	0 x	0 x	x 1

$$\begin{aligned}
 J_{A1} &= 1 \\
 K_{A1} &= 1 \\
 J_{A2} &= A_1 A_1' \\
 K_{A2} &= A_1 \\
 J_{A4} &= A_1 A_2 \\
 K_{A4} &= A_1 A_2' \\
 J_{A8} &= A_1 A_2 A_4 \\
 K_{A8} &= A_1
 \end{aligned}$$

$$d(A_8, A_4, A_2, A_1) = \Sigma(10, 11, 12, 13, 14, 15)$$

6.20 (a)

Block diagram of 4-bit circuit:

16-bit counter needs 4 circuits with output carry connected to the count input of the next stage.

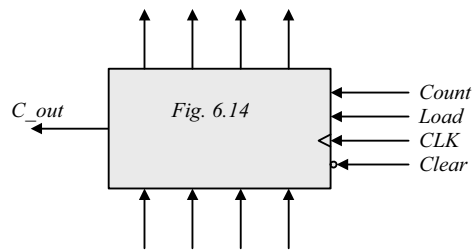

(b)

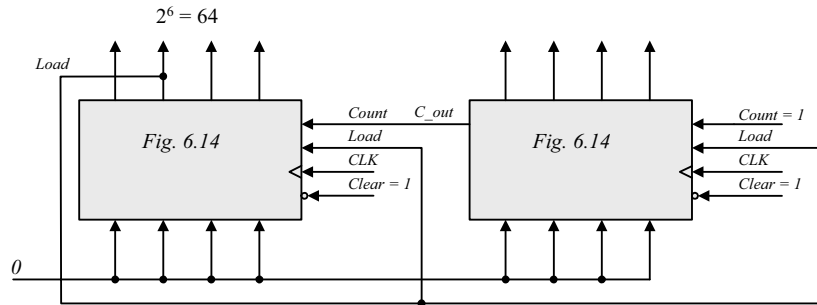

6.21 (a)

$$J_{A0} = LI_0 + L'C \quad KA_0 = LI_0' + L'C$$

(b)

$$\begin{aligned}
 J &= [L(LI)]'(L + C) = (L' + LI)(L + C) \\
 LI + L'C + LIC &= LI + L'C \text{ (use a map)} \\
 K &= (LI)'(L + C) = (L' + I')(L + C) = LI' + L'C
 \end{aligned}$$

6.22

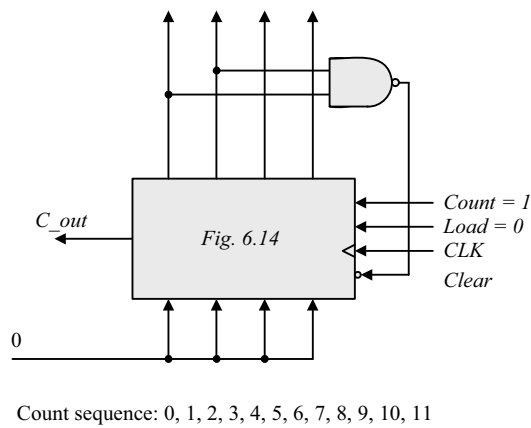
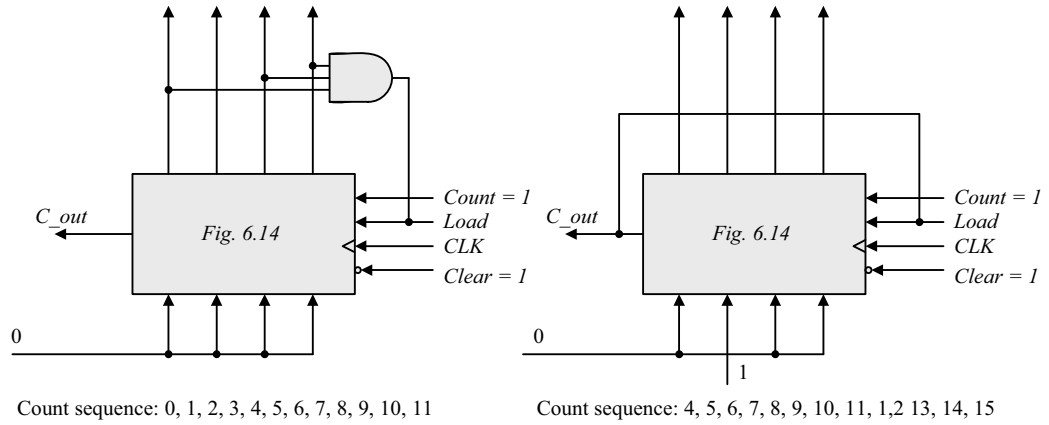

**6.23** Use a 3-bit counter and a flip-flop (initially at 0). A start signal sets the flip-flop, which in turn enables the counter. On the count of 7 (binary 111) reset the flip-flop to 0 to disable the count (with the value of 000).

**6.24**

Present state <i>ABC</i>	Next state <i>ABC</i>	Flip-flop inputs		
		$T_A$	$T_B$	$T_C$
000	001	0	0	1
001	011	0	1	0
010	xxx	x	x	x
011	111	1	1	0
100	000	1	1	0
101	xxx	x	x	x
110	100	0	1	0
111	110	0	0	1

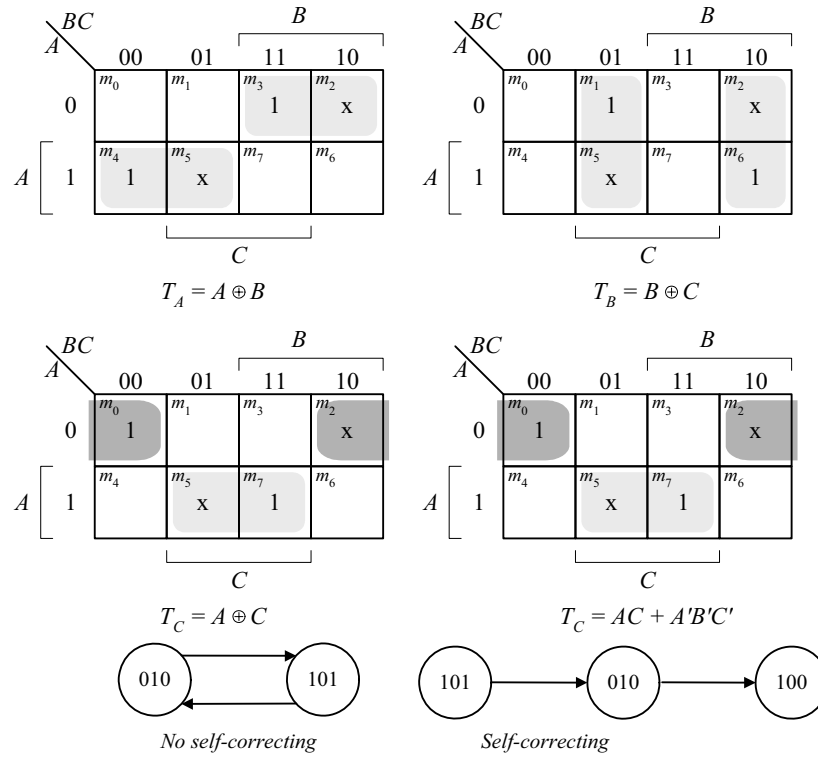

6.25 (a) Use a 6-bit ring counter.

(b)

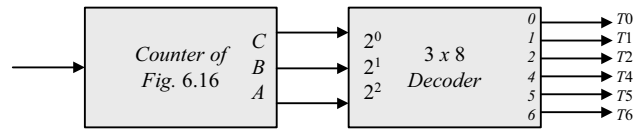

6.26 The clock generator has a period of 12.5 ns. Use a 2-bit counter to count four pulses.

$80/4 = 20 \text{ MHz}$ ; cycle time =  $1000 \times 10^{-9} / 20 = 50 \text{ ns}$ .

6.27

Present state	Next state	Flip-flop inputs					
		$J_A$	$K_A$	$J_B$	$K_B$	$J_C$	$K_C$
ABC	ABC						
000	001	0	x	0	x	1	x
001	010	0	x	1	x	x	1
010	011	0	x	x	0	1	x
011	100	1	x	x	1	x	1
100	100	x	x	0	0	1	x
101	110	x	x	1	x	x	1
110	000	x	x	x	1	0	x
111	xxx	x	x	x	x	x	x



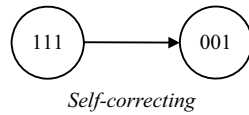
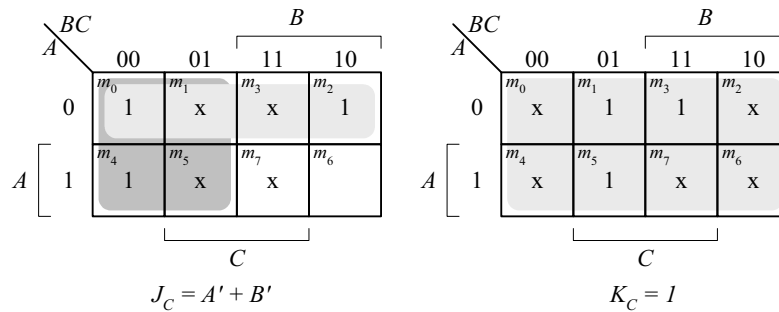
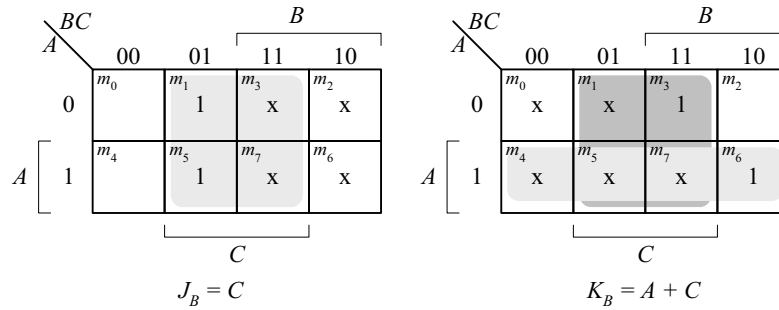
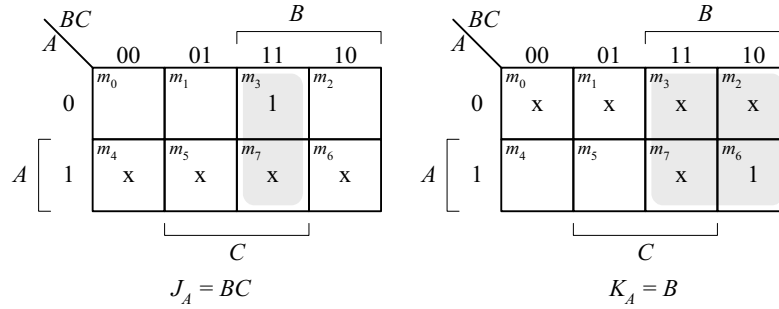

6.28

Present state ABC	Next state ABC
000	001
001	010
010	100
011	xxx
100	110
101	xxx
110	000
111	xxx

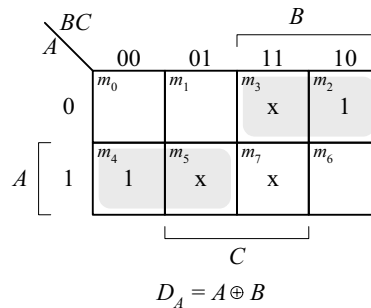

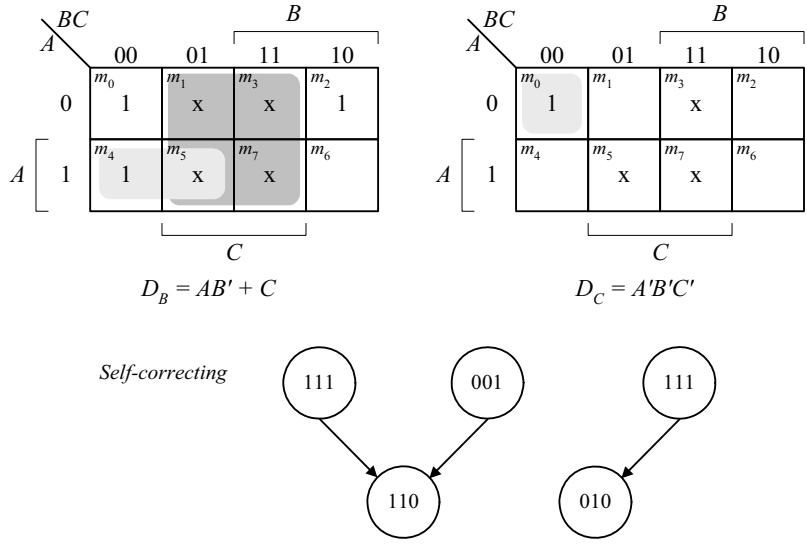

**6.29** (a) The 8 valid states are listed in Fig. 8.18(b), with the sequence: 0, 8, 12, 14, 15, 7, 3, 1, 0, ....

The 8 unused states and their next states are shown below:

State	Next state	All invalid states
ABCE	ABCE	
0000	1001	9
0100	1010	10
0101	0010	2
0110	1011	11
1001	0100	4
1010	1101	13
1011	0101	5
1101	0110	6

(b) Modification:  $D_C = (A + C)B$ .

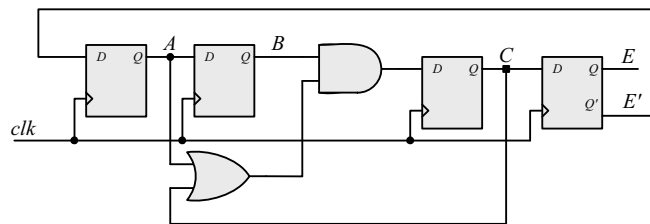

The valid states are the same as in (a). The unused states have the following sequences: 2 → 9 → 4 → 8 and 10 → 13 → 6 → 11 → 5 → 0. The final states, 0 and 8, are valid.

6.30

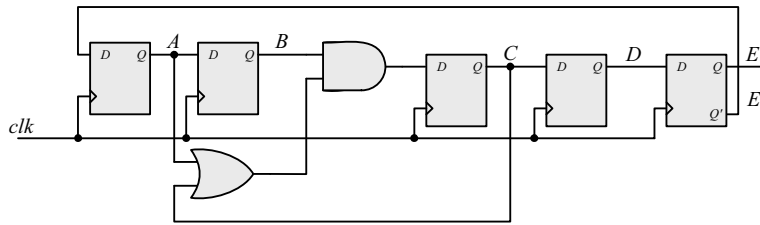

The 5-bit Johnson counter has the following state sequence:

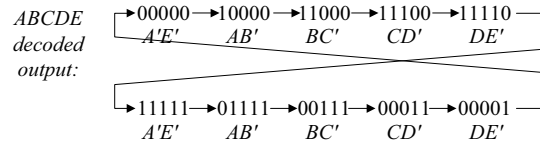

6.31

```

module Reg_4_bit_beh (output reg A3, A2, A1, A0, input I3, I2, I1, I0, Clock, Clear);
always @ (posedge Clock, negedge Clear)
    if (Clear == 0) {A3, A2, A1, A0} <= 4'b0;
    else {A3, A2, A1, A0} <= {I3, I2, I1, I0};
endmodule
    
```

```

module Reg_4_bit_Str (output A3, A2, A1, A0, input I3, I2, I1, I0, Clock, Clear);
    DFF M3DFF (A3, I3, Clock, Clear);
    DFF M2DFF (A2, I2, Clock, Clear);
    DFF M1DFF (A1, I1, Clock, Clear);
    DFF M0DFF (A0, I0, Clock, Clear);
endmodule
    
```

```

module DFF(output reg Q, input D, clk, clear);
always @ (posedge clk, posedge clear)
    if (clear == 0) Q <= 0; else Q <= D;
endmodule
    
```

```

module t_Reg_4_bit ();
wire A3_beh, A2_beh, A1_beh, A0_beh;
wire A3_str, A2_str, A1_str, A0_str;
reg I3, I2, I1, I0, Clock, Clear;
wire [3: 0] I_data = {I3, I2, I1, I0};
wire [3: 0] A_beh = {A3_beh, A2_beh, A1_beh, A0_beh};
wire [3: 0] A_str = {A3_str, A2_str, A1_str, A0_str};
    
```

```

Reg_4_bit_beh M_beh (A3_beh, A2_beh, A1_beh, A0_beh, I3, I2, I1, I0, Clock, Clear);
Reg_4_bit_Str M_str (A3_str, A2_str, A1_str, A0_str, I3, I2, I1, I0, Clock, Clear);
    
```

```

initial #100 $finish;
initial begin Clock = 0; forever #5 Clock = ~Clock; end
initial begin Clear = 0; #2 Clear = 1; end
integer K;
initial begin
    for (K = 0; K < 16; K = K + 1) begin {I3, I2, I1, I0} = K; #10 ; end
end
endmodule
    
```

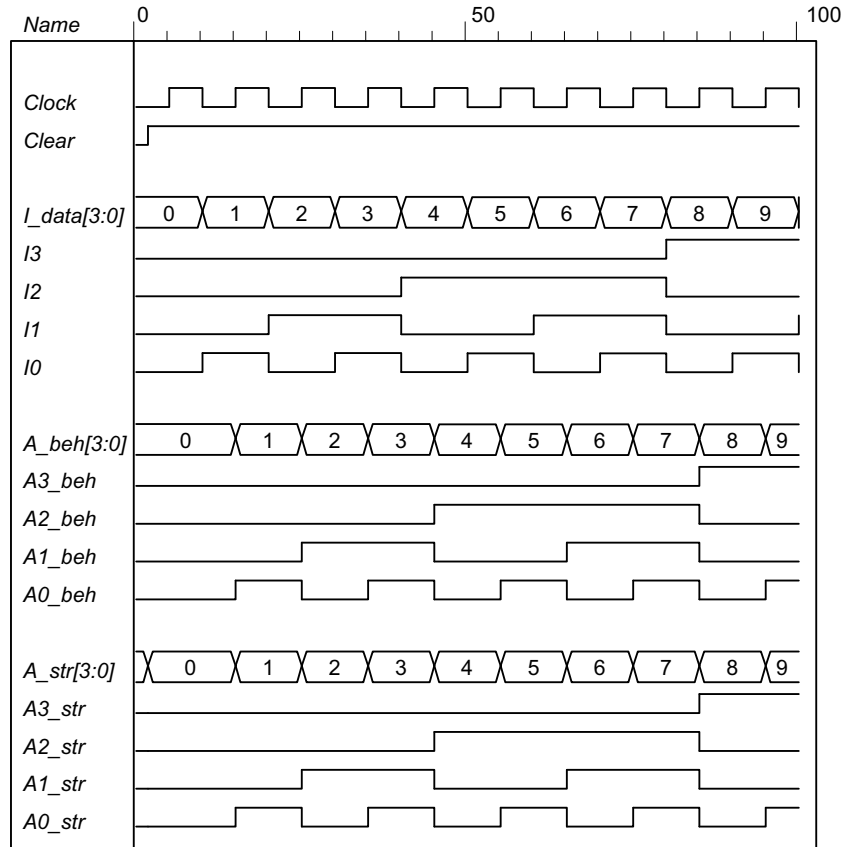

6.32 (a)

```

module Reg_4_bit_Load (output reg A3, A2, A1, A0, input I3, I2, I1, I0, Load, Clock, Clear);
  always @ (posedge Clock, negedge Clear)
    if (Clear == 0) {A3, A2, A1, A0} <= 4'b0;
    else if (Load) {A3, A2, A1, A0} <= {I3, I2, I1, I0};
endmodule

module t_Reg_4_Load ();
  wire A3_beh, A2_beh, A1_beh, A0_beh;
  reg I3, I2, I1, I0, Load, Clock, Clear;
  wire [3: 0] I_data = {I3, I2, I1, I0};
  wire [3: 0] A_beh = {A3_beh, A2_beh, A1_beh, A0_beh};

  Reg_4_bit_Load M0 (A3_beh, A2_beh, A1_beh, A0_beh, I3, I2, I1, I0, Load, Clock, Clear);

  initial #100 $finish;
  initial begin Clock = 0; forever #5 Clock = ~Clock; end
  initial begin Clear = 0; #2 Clear = 1; end
  integer K;
  initial fork
    #20 Load = 1;
    #30 Load = 0;
    #50 Load = 1;
  join
  initial begin
    for (K = 0; K < 16; K = K + 1) begin {I3, I2, I1, I0} = K; #10 ; end
  end
endmodule

```

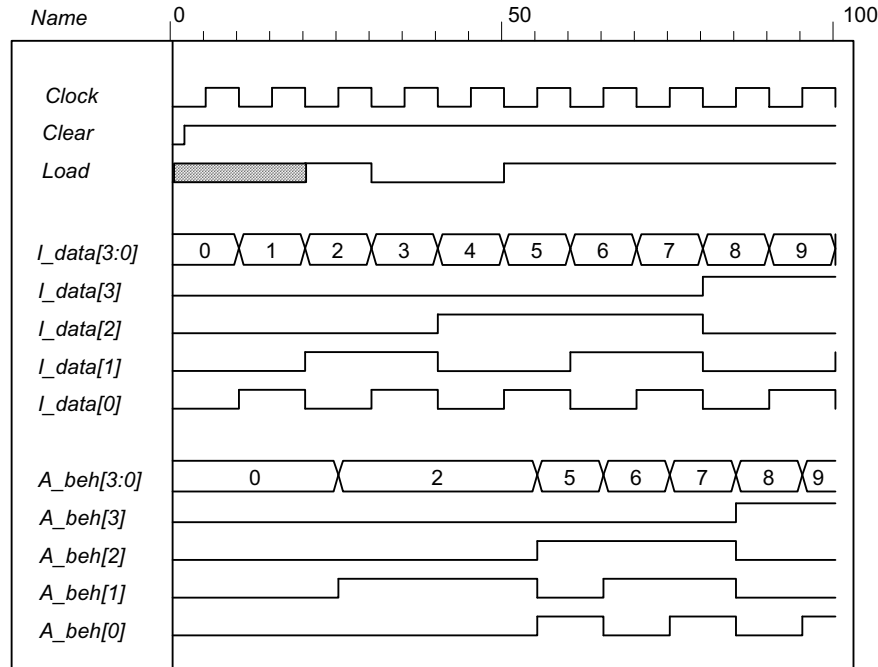

(b)

```
module Reg_4_bit_Load_str (output A3, A2, A1, A0, input I3, I2, I1, I0, Load, Clock, Clear);
```

```
  wire y3, y2, y1, y0;
  mux_2 M3 (y3, A3, I3, Load);
  mux_2 M2 (y2, A2, I2, Load);
  mux_2 M1 (y1, A1, I1, Load);
  mux_2 M0 (y0, A0, I0, Load);
```

```
  DFF M3DFF (A3, y3, Clock, Clear);
  DFF M2DFF (A2, y2, Clock, Clear);
  DFF M1DFF (A1, y1, Clock, Clear);
  DFF M0DFF (A0, y0, Clock, Clear);
```

```
endmodule
```

```
module DFF(output reg Q, input D, clk, clear);
```

```
  always @ (posedge clk, posedge clear)
    if (clear == 0) Q <= 0; else Q <= D;
```

```
endmodule
```

```
module mux_2 (output y, input a, b, sel);
```

```
  assign y = sel ? a : b;
```

```
endmodule
```

```
module t_Reg_4_Load_str ();
```

```
  wire A3, A2, A1, A0;
  reg I3, I2, I1, I0, Load, Clock, Clear;
  wire [3:0] I_data = {I3, I2, I1, I0};
  wire [3:0] A = {A3, A2, A1, A0};
```

```
  Reg_4_bit_Load_str M0 (A3, A2, A1, A0, I3, I2, I1, I0, Load, Clock, Clear);
```

```

initial #100 $finish;
initial begin Clock = 0; forever #5 Clock = ~Clock; end
initial begin Clear = 0; #2 Clear = 1; end
integer K;
initial fork
    #20 Load = 1;
    #30 Load = 0;
    #50 Load = 1;
    #80 Load = 0;
join
initial begin
    for (K = 0; K < 16; K = K + 1) begin {I3, I2, I1, I0} = K; #10 ; end
end
endmodule

```

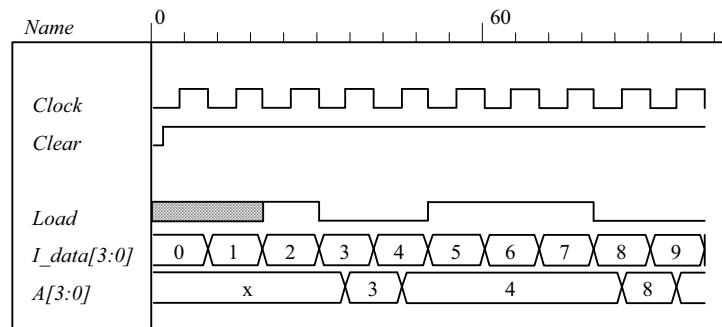

(c)

```

module Reg_4_bit_Load_beh (output reg A3, A2, A1, A0, input I3, I2, I1, I0, Load, Clock, Clear);
    always @ (posedge Clock, negedge Clear)
        if (Clear == 0) {A3, A2, A1, A0} <= 4'b0;
        else if (Load) {A3, A2, A1, A0} <= {I3, I2, I1, I0};
endmodule

```

```

module Reg_4_bit_Load_str (output A3, A2, A1, A0, input I3, I2, I1, I0, Load, Clock, Clear);
    wire y3, y2, y1, y0;
    mux_2 M3 (y3, A3, I3, Load);
    mux_2 M2 (y2, A2, I2, Load);
    mux_2 M1 (y1, A1, I1, Load);
    mux_2 M0 (y0, A0, I0, Load);

```

```

    DFF M3DFF (A3, y3, Clock, Clear);
    DFF M2DFF (A2, y2, Clock, Clear);
    DFF M1DFF (A1, y1, Clock, Clear);
    DFF M0DFF (A0, y0, Clock, Clear);
endmodule

```

```

module DFF(output reg Q, input D, clk, clear);
    always @ (posedge clk, posedge clear)
        if (clear == 0) Q <= 0; else Q <= D;
endmodule

```

```

module mux_2 (output y, input a, b, sel);
    assign y = sel ? a : b;
endmodule

```

```

module t_Reg_4_Load_str ();
  wire A3_beh, A2_beh, A1_beh, A0_beh;
  wire A3_str, A2_str, A1_str, A0_str;
  reg I3, I2, I1, I0, Load, Clock, Clear;
  wire [3: 0] I_data, A_beh, A_str;
  assign I_data = {I3, I2, I1, I0};
  assign A_beh = {A3_beh, A2_beh, A1_beh, A0_beh};
  assign A_str = {A3_str, A2_str, A1_str, A0_str};

  Reg_4_bit_Load_str M0 (A3_beh, A2_beh, A1_beh, A0_beh, I3, I2, I1, I0, Load, Clock, Clear);
  Reg_4_bit_Load_str M1 (A3_str, A2_str, A1_str, A0_str, I3, I2, I1, I0, Load, Clock, Clear);

  initial #100 $finish;
  initial begin Clock = 0; forever #5 Clock = ~Clock; end
  initial begin Clear = 0; #2 Clear = 1; end
  integer K;
  initial fork
    #20 Load = 1;
    #30 Load = 0;
    #50 Load = 1;
    #80 Load = 0;
  join
  initial begin
    for (K = 0; K < 16; K = K + 1) begin {I3, I2, I1, I0} = K; #10 ; end
  end
endmodule

```

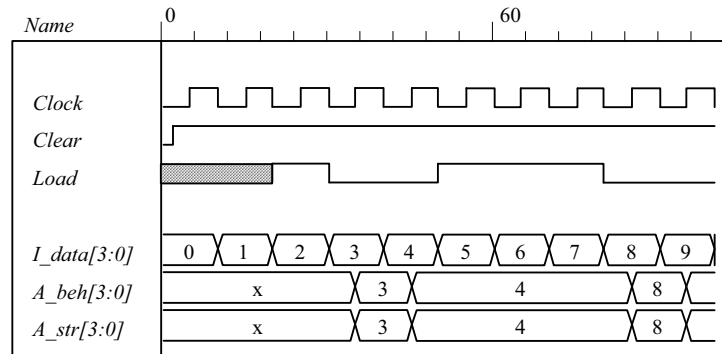

6.33

// Stimulus for testing the binary counter of Example 6-3

```

module testcounter;
  reg Count, Load, CLK, Clr;
  reg [3: 0] IN;
  wire CO;
  wire [3: 0] A;
  Binary_Counter_4_Par_Load M0 (
    A,      // Data output
    CO,    // Output carry
    IN,    // Data input
    Count, // Active high to count
    Load,  // Active high to load
    CLK,   // Positive edge sensitive
    Clr    // Active low
  );

```

```

always
  #5 CLK = ~CLK;
initial
  begin
    Clr = 0;           // Clear de-asserted
    CLK = 1;          // Clock initialized high
    Load = 0; Count = 1; // Enable count
    #5 Clr = 1;       // Clears count, then counts for five cycles
    #50 Load = 1; IN = 4'b1100; // Count is set to 4'b1100 (120)
    #10 Load = 0;
    #70 Count = 0;    // Count is deasserted at t = 135
    #20 $finish;     // Terminate simulation
  end
endmodule
// Four-bit binary counter with parallel load
// See Figure 6-14 and Table 6-6
module Binary_Counter_4_Par_Load (
  output reg [3:0] A_count, // Data output
  output C_out, // Output carry
  input [3:0] Data_in, // Data input
  input Count, // Active high to count
  Load, // Active high to load
  CLK, // Positive edge sensitive
  Clear // Active low
);

```

```

assign C_out = Count & (~Load) & (A_count == 4'b1111);
always @ (posedge CLK, negedge Clear)
  if (~Clear) A_count <= 4'b0000;
  else if (Load) A_count <= Data_in;
  else if (Count) A_count <= A_count + 1'b1;
  else A_count <= A_count; // redundant statement
endmodule

```

// Note: a preferred description if the clock is given by:  
 // **initial begin** CLK = 0; **forever** #5 CLK = ~CLK; **end**

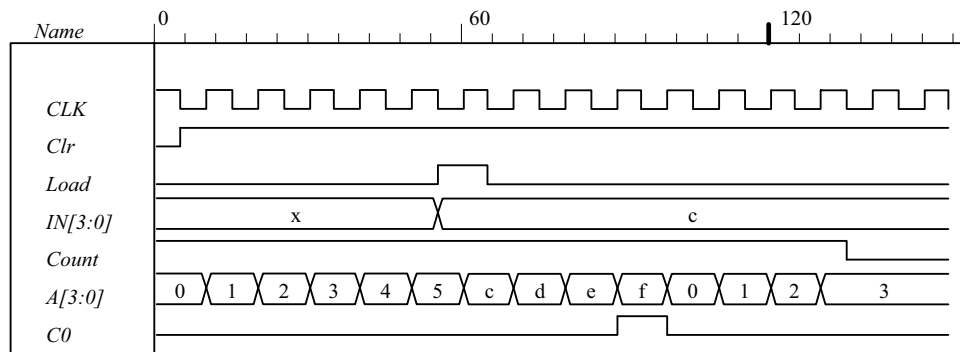

6.34

```

module Shiftreg (SI, SO, CLK);
  input SI, CLK;
  output SO;
  reg [3: 0] Q;
  assign SO = Q[0];
  always @ (posedge CLK)
    Q = {SI, Q[3: 1]};
endmodule

```



```
// Test plan
//
// Verify that data shift through the register
// Set SI =1 for 4 clock cycles
// Hold SI =1 for 4 clock cycles
// Set SI = 0 for 4 clock cycles
// Verify that data shifts out of the register correctly

module t_Shiftreg;
  reg SI, CLK;
  wire SO;

  Shiftreg M0 (SI, SO, CLK);

  initial #130 $finish;
  initial begin CLK = 0; forever #5 CLK = ~CLK; end
  initial fork
    SI = 1'b1;
    #80 SI = 0;
  join
endmodule
```

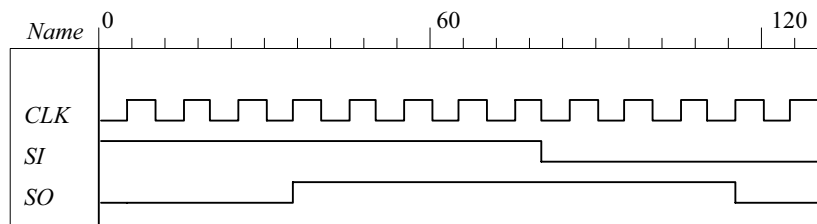

6.35 (a) Note that *Load* has priority over *Clear*.

```
module Prob_6_35a (output [3: 0] A, input [3:0] I, input Load, Clock, Clear);
  Register_Cell R0 (A[0], I[0], Load, Clock, Clear);
  Register_Cell R1 (A[1], I[1], Load, Clock, Clear);
  Register_Cell R2 (A[2], I[2], Load, Clock, Clear);
  Register_Cell R3 (A[3], I[3], Load, Clock, Clear);
endmodule
```

```
module Register_Cell (output A, input I, Load, Clock, Clear);
  DFF M0 (A, D, Clock);
  not (Load_b, Load);
  not (w1, Load_b);
  not (Clear_b, Clear);
  and (w2, I, w1);
  and (w3, A, Load_b, Clear_b);
  or (D, w2, w3);
endmodule
```

```
module DFF (output reg Q, input D, clk);
  always @ (posedge clk) Q <= D;
endmodule
```

```
module t_Prob_6_35a ( );

  wire [3: 0] A;
  reg [3: 0] I;
  reg Clock, Clear, Load;
```

```

Prob_6_35a M0 ( A, I, Load, Clock, Clear);
initial #150 $finish;
initial begin Clock = 0; forever #5 Clock = ~Clock; end
initial fork
I = 4'b1010; Clear = 1;
#40 Clear = 0;
Load = 0;
#20 Load = 1;
#40 Load = 0;
join
endmodule

```

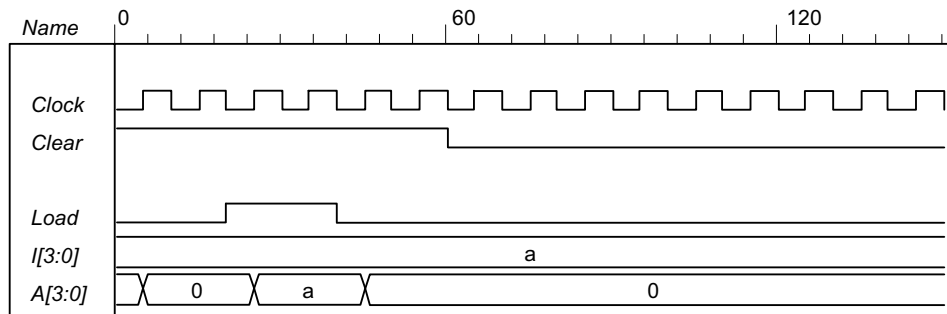

(b) Note: The solution below replaces the solution given on the CD.

```

module Prob_6_35b (output reg [3: 0] A, input [3:0] I, input Load, Clock, Clear);
always @ (posedge Clock)
if (Load) A <= I;
else if (Clear) A <= 4'b0;
//else A <= A; // redundant statement
endmodule

```

```

module t_Prob_6_35b ( );

```

```

wire [3: 0] A;
reg [3: 0] I;
reg Clock, Clear, Load;

```

```

Prob_6_35b M0 ( A, I, Load, Clock, Clear);
initial #150 $finish;
initial begin Clock = 0; forever #5 Clock = ~Clock; end
initial fork
I = 4'b1010; Clear = 1;
#60 Clear = 0;
Load = 0;
#20 Load = 1;
#40 Load = 0;
join
endmodule

```

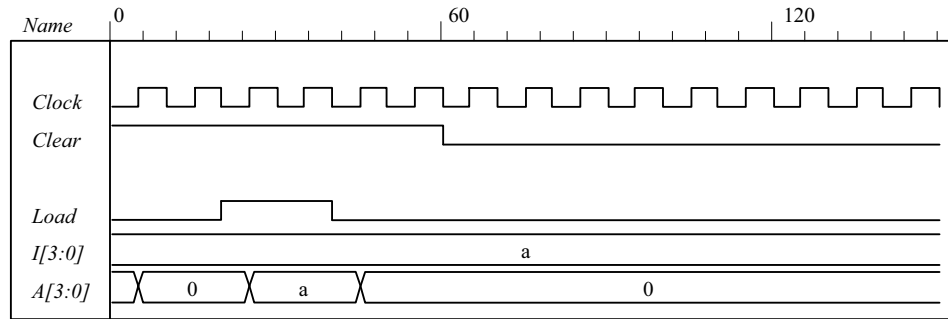

(c)

```

module Prob_6_35c (output [3: 0] A, input [3:0] I, input Shift, Load, Clock);
    Register_Cell R0 (A[0], I[0], A[1], Shift, Load, Clock);
    Register_Cell R1 (A[1], I[1], A[2], Shift, Load, Clock);
    Register_Cell R2 (A[2], I[2], A[3], Shift, Load, Clock);
    Register_Cell R3 (A[3], I[3], A[0], Shift, Load, Clock);
endmodule

```

```

module Register_Cell (output A, input I, Serial_in, Shift, Load, Clock);
    DFF M0 (A, D, Clock);
    not (Shift_b, Shift);
    not (Load_b, Load);
    and (w1, Shift, Serial_in);
    and (w2, Shift_b, Load, I);

    and (w3, A, Shift_b, Load_b);
    or (D, w1, w2, w3);
endmodule

```

```

module DFF (output reg Q, input D, clk);
always @ (posedge clk) Q <= D;
endmodule

```

```

module t_Prob_6_35c ( );

    wire [3: 0] A;
    reg [3: 0] I;
    reg Clock, Shift, Load;

    Prob_6_35c M0 (A, I, Shift, Load, Clock);
    initial #150 $finish;
    initial begin Clock = 0; forever #5 Clock = ~Clock; end
    initial fork
        I = 4'b1010;
        Load = 0; Shift = 0;
        #20 Load = 1;
        #40 Load = 0;
        #50 Shift = 1;
    join
endmodule

```

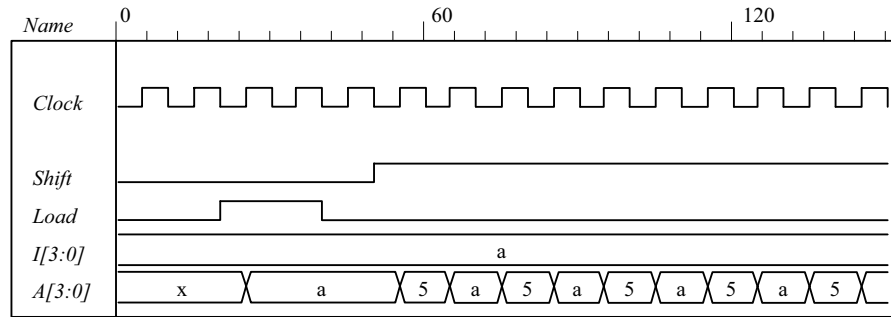

(d)

```

module Prob_6_35d (output reg [3: 0] A, input [3:0] I, input Shift, Load, Clock, Clear);
always @ (posedge Clock)
    if (Shift) A <= {A[0], A[3:1]};
    else if (Load) A <= I;
    else if (Clear) A <= 4'b0;
    //else A <= A; // redundant statement
endmodule

```

```

module t_Prob_6_35d ( );

```

```

wire [3: 0] A;
reg [3: 0] I;
reg Clock, Clear, Shift, Load;

```

```

    Prob_6_35d M0 ( A, I, Shift, Load, Clock, Clear);
initial #150 $finish;
initial begin Clock = 0; forever #5 Clock = ~Clock; end
initial fork
    I = 4'b1010; Clear = 1;
    #100 Clear = 0;
    Load = 0;
    #20 Load = 1;
    #40 Load = 0;
    #30 Shift = 1;
    #90 Shift = 0;
join
endmodule

```

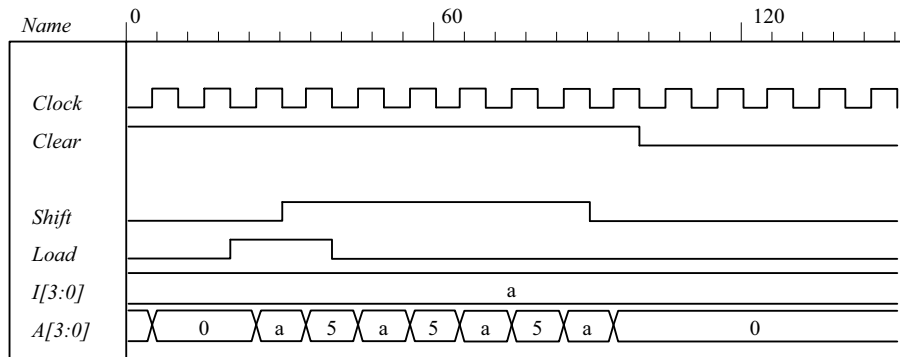

(e)

```
module Shift_Register
  (output [3: 0] A_par, input [3: 0] I_par, input MSB_in, LSB_in, s1, s0, CLK, Clear);
  wire y3, y2, y1, y0;
  DFF D3 (A_par[3], y3, CLK, Clear);
  DFF D2 (A_par[2], y2, CLK, Clear);
  DFF D1 (A_par[1], y1, CLK, Clear);
  DFF D0 (A_par[0], y0, CLK, Clear);

  MUX_4x1 M3 (y3, I_par[3], A_par[2], MSB_in, A_par[3], s1, s0);
  MUX_4x1 M2 (y2, I_par[2], A_par[1], A_par[3], A_par[2], s1, s0);
  MUX_4x1 M1 (y1, I_par[1], A_par[0], A_par[2], A_par[1], s1, s0);
  MUX_4x1 M0 (y0, I_par[0], LSB_in, A_par[1], A_par[0], s1, s0);
endmodule

module MUX_4x1 (output reg y, input I3, I2, I1, I0, s1, s0);
  always @ (I3, I2, I1, I0, s1, s0)
    case ({s1, s0})
      2'b11: y = I3;
      2'b10: y = I2;
      2'b01: y = I1;
      2'b00: y = I0;
    endcase
endmodule

module DFF (output reg Q, input D, clk, reset_b);
  always @ (posedge clk, negedge reset_b) if (reset_b == 0) Q <= 0; else Q <= D;
endmodule

module t_Shift_Register ( );
  wire [3: 0] A_par;
  reg [3: 0] I_par;
  reg MSB_in, LSB_in, s1, s0, CLK, Clear;

  Shift_Register M_SR( A_par, I_par, MSB_in, LSB_in, s1, s0, CLK, Clear);
  initial #300 $finish;
  initial begin CLK = 0; forever #5 CLK = ~CLK; end
  initial fork
    MSB_in = 0; LSB_in = 0;
    Clear = 0; // Active-low reset
    s1 = 0; s0 = 0; // No change
    #10 Clear = 1;
    #10 I_par = 4'hA;
    #30 begin s1 = 1; s0 = 1; end // 00: load I_par into A_par
    #50 s1 = 0; // 01: shift right (1010 to 0101 to 0010 to 0001 to 0000)
    #90 begin s1 = 1; s0 = 1; end // 11: reload A with 1010
    #100 s0 = 0; // 10: shift left (1010 to 0100 to 0010 to 0000)
    #140 begin s1 = 1; s0 = 1; MSB_in = 1; LSB_in = 1; end // Repeat with MSB and LSB
    #150 s1 = 0;
    #190 begin s1 = 1; s0 = 1; end // reload with A = 1010
    #200 s0 = 0; // Shift left
    #220 s1 = 0; // Pause
    #240 s1 = 1; // Shift left
  join
endmodule
```

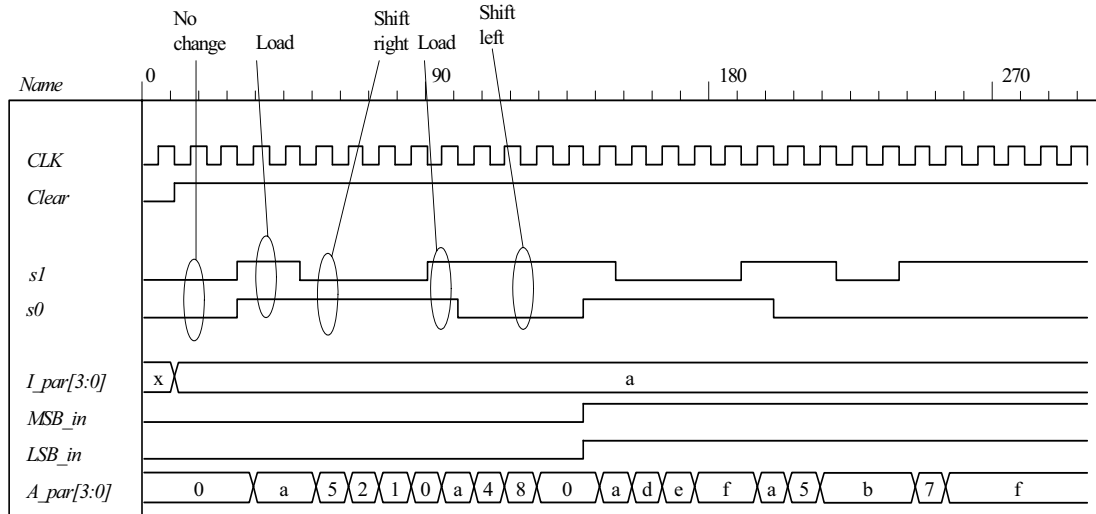

(f)

```

module Shift_Register_BEH
  (output [3: 0] A_par, input [3: 0] I_par, input MSB_in, LSB_in, s1, s0, CLK, Clear);

```

```

always @ (posedge CLK, negedge Clear) if (Clear == 0) A_par <= 4'b0;
else case ({s1, s0})
  2'b11: A_par <= I_par;
  2'b01: A_par <= {MSB_in, A_par[3: 1]};
  2'b10: A_par <= {A_par[2: 0], LSB_in};
  2'b00: A_par <= A_par;

```

```

endcase
endmodule

```

```

module t_Shift_Register ( );
  wire [3: 0] A_par;
  reg [3: 0] I_par;
  reg MSB_in, LSB_in, s1, s0, CLK, Clear;

```

```

Shift_Register_BEH M_SR( A_par, I_par, MSB_in, LSB_in, s1, s0, CLK, Clear);
initial #300 $finish;
initial begin CLK = 0; forever #5 CLK = ~CLK; end
initial fork
  MSB_in = 0; LSB_in = 0;
  Clear = 0; // Active-low reset
  s1 = 0; s0 = 0; // No change
  #10 Clear = 1;
  #10 I_par = 4'hA;
  #30 begin s1 = 1; s0 = 1; end // 00: load I_par into A_par
  #50 s1 = 0; // 01: shift right (1010 to 0101 to 0010 to 0001 to 0000)
  #90 begin s1 = 1; s0 = 1; end // 11: reload A with 1010
  #100 s0 = 0; // 10: shift left (1010 to 0100 to 1000 to 000)
  #140 begin s1 = 1; s0 = 1; MSB_in = 1; LSB_in = 1; end // Repeat with MSB and LSB
  #150 s1 = 0;
  #190 begin s1 = 1; s0 = 1; end // reload with A = 1010
  #200 s0 = 0; // Shift left
  #220 s1 = 0; // Pause
  #240 s1 = 1; // Shift left

```

```

join
endmodule

```

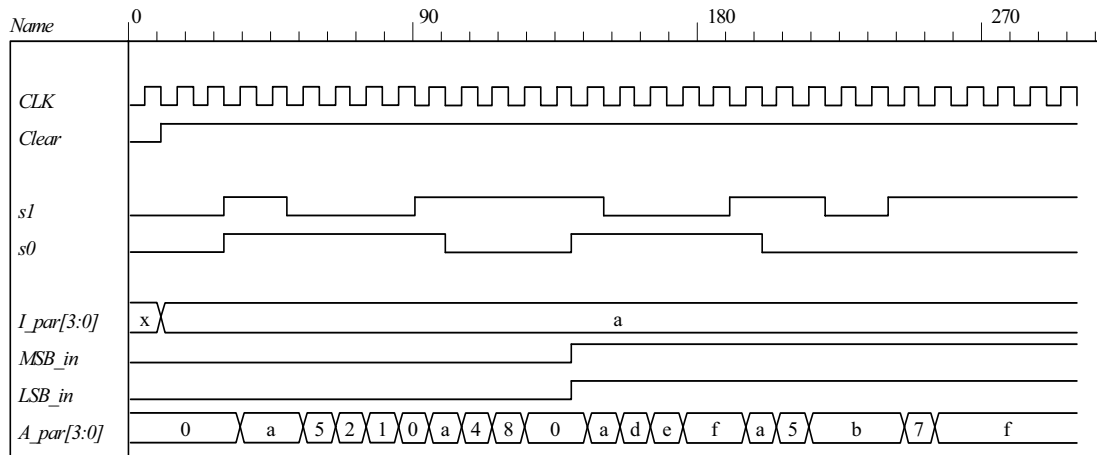

(g)

```

module Ripple_Counter_4bit (output [3: 0] A, input Count, reset_b);
  reg A0, A1, A2, A3;
  assign A = {A3, A2, A1, A0};
  always @ (negedge Count, negedge reset_b)
    if (reset_b == 0) A0 <= 0; else A0 <= ~A0;

  always @ (negedge A0, negedge reset_b)
    if (reset_b == 0) A1 <= 0; else A1 <= ~A1;

  always @ (negedge A1, negedge reset_b)
    if (reset_b == 0) A2 <= 0; else A2 <= ~A2;

  always @ (negedge A2, negedge reset_b)
    if (reset_b == 0) A3 <= 0; else A3 <= ~A3;
endmodule

module t_Ripple_Counter_4bit ();
  wire [3: 0] A;
  reg Count, reset_b;

  Ripple_Counter_4bit M0 (A, Count, reset_b);

  initial #300 $finish;
  initial fork
    reset_b = 0; // Active-low reset
  #60 reset_b = 1;

  Count = 1;
  #15 Count = 0;
  #30 Count = 1;
  #85 begin Count = 0; forever #10 Count = ~Count; end
  join
endmodule

```

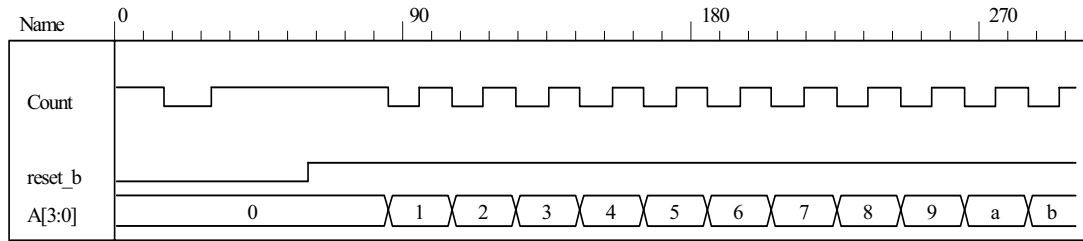

(h) Note: This version of the solution situates the data shift registers in the test bench.

```

module Serial_Subtractor (output SO, input SI_A, SI_B, shift_control, clock, reset_b);
// See Fig. 6.5 and Problem 6.9a (2s complement serial subtractor)
reg [1: 0] sum;
wire mem = sum[1];
assign SO = sum[0];

```

```

always @ (posedge clock, negedge reset_b)
if (reset_b == 0) begin
    sum <= 2'b10;
end
else if (shift_control) begin
    sum <= SI_A + (!SI_B) + sum[1];
end
endmodule

```

```

module t_Serial_Subtractor ();
wire SI_A, SI_B;
reg shift_control, clock, reset_b;

```

```

Serial_Subtractor M0 (SO, SI_A, SI_B, shift_control, clock, reset_b);

```

```

initial #250 $finish;
initial begin clock = 0; forever #5 clock = ~clock; end
initial fork
    shift_control = 0;
    #10 reset_b = 0;
    #20 reset_b = 1;
    #22 shift_control = 1;
    #105 shift_control = 0;
    #112 reset_b = 0;
    #114 reset_b = 1;
    #122 shift_control = 1;
    #205 shift_control = 0;
join
reg [7: 0] A, B, SO_reg;
wire s7;
assign s7 = SO_reg[7];
assign SI_A = A[0];
assign SI_B = B[0];
wire SI_B_bar = ~SI_B;
initial fork
    A = 8'h5A;
    B = 8'h0A;
    #122 A = 8'h0A;
    #122 B = 8'h5A;
join

```



```
always @ (negedge clock, negedge reset_b)  
  if (reset_b == 0) SO_reg <= 0;  
  else if (shift_control == 1) begin  
    SO_reg <= {SO, SO_reg[7: 1]};  
    A <= A >> 1;  
    B <= B >> 1;  
  end  
  wire negative = !M0.sum[1];  
  wire [7: 0] magnitude = (!negative)? SO_reg: 1'b1 + ~SO_reg;  
endmodule
```

Simulation results are shown for  $5Ah - 0Ah = 50h = 80d$  and  $0Ah - 5Ah = -80$ . The magnitude of the result is also shown.

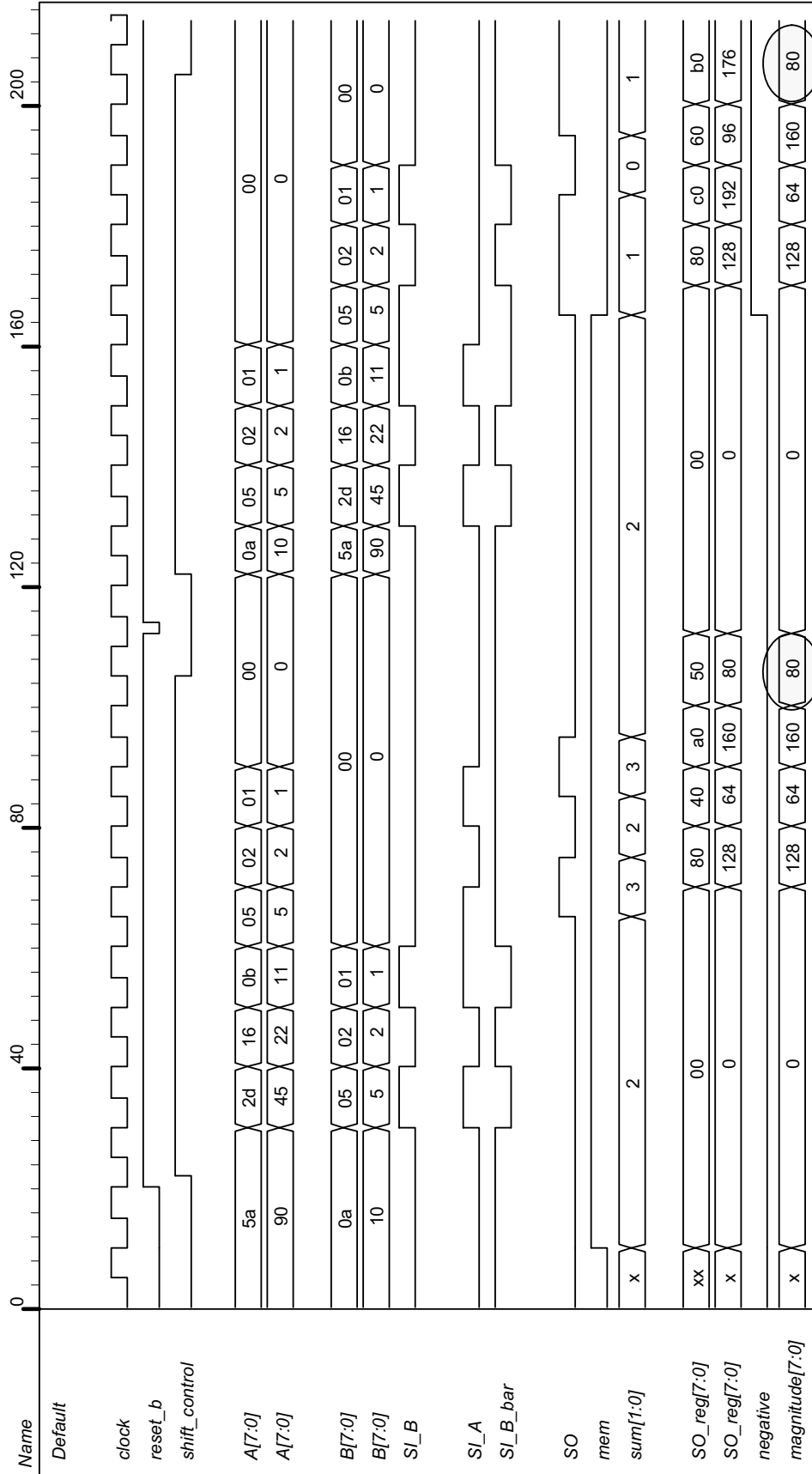

(i) See Prob. 6.35h.

(j)

```
module Serial_Two Comp (output y, input [7: 0] data, input load, shift_control, Clock, reset_b);  
  reg [7: 0] SReg;  
  reg Q;  
  wire SO = SReg [0];  
  assign y = SO ^ Q;  
  always @ (posedge Clock, negedge reset_b)  
  if (reset_b == 0) begin  
    SReg <= 0;  
    Q <= 0;  
  end  
  else begin  
    if (load) SReg = data;  
    else if (shift_control) begin  
      Q <= Q | SO;  
      SReg <= {y, SReg[7: 1]};  
    end  
  end  
endmodule
```

```
module t_Serial_Two Comp ();  
  wire y;  
  reg [7: 0] data;  
  reg load, shift_control, Clock, reset_b;  
  
  Serial_Two Comp M0 (y, data, load, shift_control, Clock, reset_b);  
  
  reg [7: 0] twos_comp;  
  
  always @ (posedge Clock, negedge reset_b)  
  if (reset_b == 0) twos_comp <= 0;  
  else if (shift_control && !load) twos_comp <= {y, twos_comp[7: 1]};  
  
  initial #200 $finish;  
  initial begin Clock = 0; forever #5 Clock = ~Clock; end  
  initial begin #2 reset_b = 0; #4 reset_b = 1; end  
  
  initial fork  
    data = 8'h5A;  
    #20 load = 1;  
    #30 load = 0;  
    #50 shift_control = 1;  
    #50 begin repeat (9) @ (posedge Clock) ;  
      shift_control = 0;  
    end  
  join  
endmodule
```

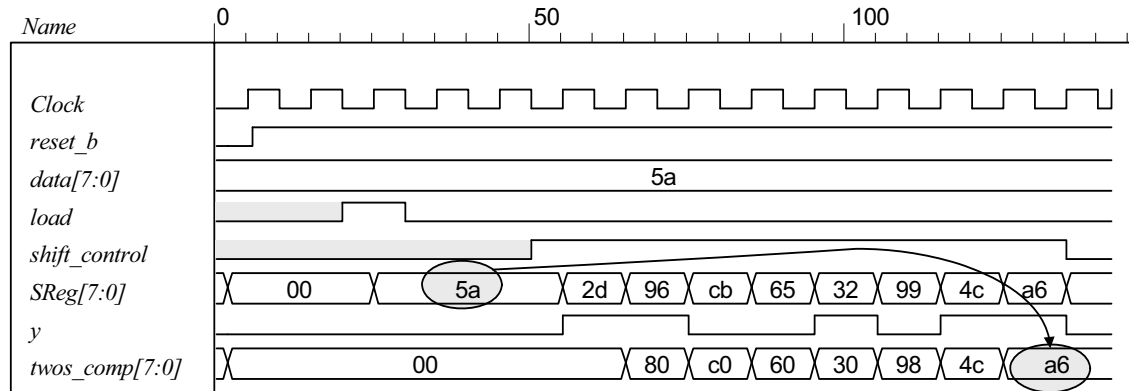

(k) From the solution to Problem 6.13:

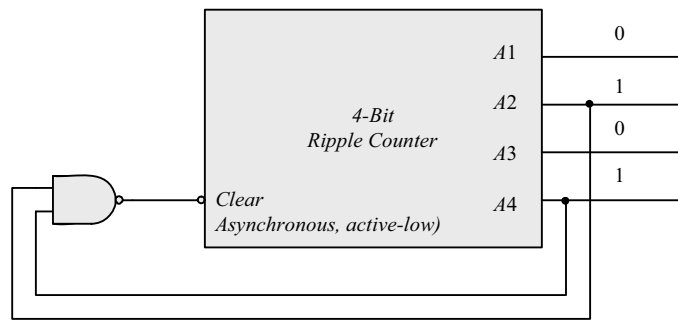

```

module Prob_6_35k_BCD_Counter (output A1, A2, A3, A4, input clk, reset_b);
    wire {A1, A2, A3, A4} = A;
    nand (Clear, A2, A4);
    Ripple_Counter_4bit M0 (A, Clear, reset_b);
endmodule

```

```

module Ripple_Counter_4bit (output [3: 0] A, input Count, reset_b);
    reg A0, A1, A2, A3;
    assign A = {A3, A2, A1, A0};
    always @ (negedge Count, negedge reset_b)
        if (reset_b == 0) A0 <= 0; else A0 <= ~A0;
    always @ (negedge A0, negedge reset_b)
        if (reset_b == 0) A1 <= 0; else A1 <= ~A1;
    always @ (negedge A1, negedge reset_b)
        if (reset_b == 0) A2 <= 0; else A2 <= ~A2;
    always @ (negedge A2, negedge reset_b)
        if (reset_b == 0) A3 <= 0; else A3 <= ~A3;
endmodule

```

```

module t_Prob_6_35k_BCD_Counter ();
    wire [3: 0] A;
    reg Count, reset_b;

    Prob_6_35k_BCD_Counter M0 (A1, A2, A3, A4, reset_b);
    initial #300 $finish;
    initial fork
        reset_b = 0;           // Active-low reset
        #60 reset_b = 1;
    /*
    Count = 1;
    #15 Count = 0;
    #30 Count = 1;

```

```
#85 begin Count = 0; forever #10 Count = ~Count; end*/
join
endmodule
```

(I)

```
module Prob_6_35l_Up_Dwn_Beh (output reg [3: 0] A, input CLK, Up, Down, reset_b);
```

```
always @ (posedge CLK, negedge reset_b)
if (reset_b ==0) A <= 4'b0000;
else case ({Up, Down})
2'b10: A <= A + 4'b0001; // Up
2'b01: A <= A - 4'b0001; // Down
default: A <= A; // Suspend (Redundant statement)
endcase
endmodule
```

```
module t_Prob_6_35l_Up_Dwn_Beh ();
```

```
wire [3: 0] A;
reg CLK, Up, Down, reset_b;
```

```
Prob_6_35l_Up_Dwn_Beh M0 (A, CLK, Up, Down, reset_b);
```

```
initial #300 $finish;
initial begin CLK = 0; forever #5 CLK = ~CLK; end
initial fork
Down = 0; Up = 0;
#10 reset_b = 0;
#20 reset_b = 1;
#40 Up = 1;
#150 Down = 1;
#220 Up = 0;
#280 Down = 0;
join
endmodule
```

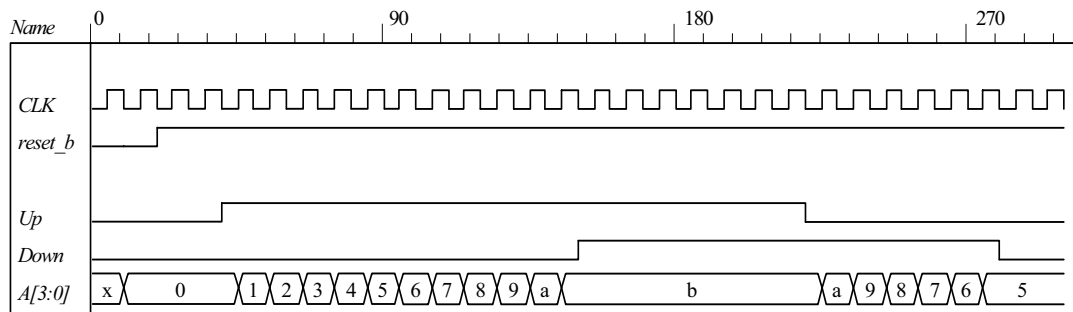

6.36 (a)

// See Fig. 6.13., 4-bit Up-Down Binary Counter

```
module Prob_6_36_Up_Dwn_Beh (output reg [3: 0] A, input CLK, Up, Down, reset_b);
```

```
always @ (posedge CLK, negedge reset_b)
if (reset_b ==0) A <= 4'b0000;
else if (Up) A <= A + 4'b0001;
else if (Down) A <= A - 4'b0001;
endmodule
```

```
module t_Prob_6_36_Up_Dwn_Beh ();
```

```
wire [3: 0] A;
reg CLK, Up, Down, reset_b;
```

```
Prob_6_36_Up_Dwn_Beh M0 (A, CLK, Up, Down, reset_b);
```

```
initial #300 $finish;
initial begin CLK = 0; forever #5 CLK = ~CLK; end
initial fork
    Down = 0; Up = 0;
    #10 reset_b = 0;
    #20 reset_b = 1;
    #40 Up = 1;
    #150 Down = 1;
    #220 Up = 0;
    #280 Down = 0;
join
endmodule
```

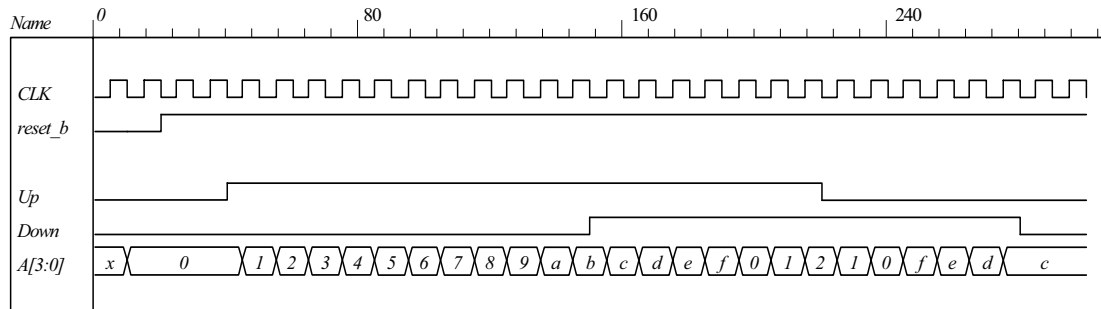

(b)

```
module Prob_6_36_Up_Dwn_Str (output [3: 0] A, input CLK, Up, Down, reset_b);
    wire Down_3, Up_3, Down_2, Up_2, Down_1, Up_1;
    wire A_0b, A_1b, A_2b, A_3b;
```

```
    stage_register SR3 (A[3], A_3b, Down_3, Up_3, Down_2, Up_2, A[2], A_2b, CLK, reset_b);
    stage_register SR2 (A[2], A_2b, Down_2, Up_2, Down_1, Up_1, A[1], A_1b, CLK, reset_b);
    stage_register SR1 (A[1], A_1b, Down_1, Up_1, Down_not_Up, Up, A[0], A_0b, CLK, reset_b);
    not (Up_b, Up);
    and (Down_not_Up, Down, Up_b);
    or (T, Up, Down_not_Up);
    Toggle_flop TF0 (A[0], A_0b, T, CLK, reset_b);
endmodule
```

```
module stage_register (output A, A_b, Down_not_Up_out, Up_out, input Down_not_Up, Up, A_in,
    A_in_b, CLK, reset_b);
```

```
    Toggle_flop T0 (A, A_b, T, CLK, reset_b);
    or (T, Down_not_Up_out, Up_out);
    and (Down_not_Up_out, Down_not_Up, A_in_b);
    and (Up_out, Up, A_in);
endmodule
```

```
module Toggle_flop (output reg Q, output Q_b, input T, CLK, reset_b);
    always @ (posedge CLK, negedge reset_b) if (reset_b == 0) Q <= 0; else Q <= Q ^ T;
    assign Q_b = ~Q;
```

```
endmodule
```

```
module t_Prob_6_36_Up_Dwn_Str ();
    wire [3: 0] A;
    reg CLK, Up, Down, reset_b;
```

```

wire T3 = M0.SR3.T;
wire T2 = M0.SR2.T;
wire T1 = M0.SR1.T;
wire T0 = M0.T;

```

```

Prob_6_36_Up_Dwn_Str M0 (A, CLK, Up, Down, reset_b);

```

```

initial #150 $finish;
initial begin CLK = 0; forever #5 CLK = ~CLK; end
initial fork
    Down = 0; Up = 0;
    #10 reset_b = 0;
    #20 reset_b = 1;
    #50 Up = 1;
    #140 Down = 1;
    #120 Up = 0;
    #140 Down = 0;
join
endmodule

```

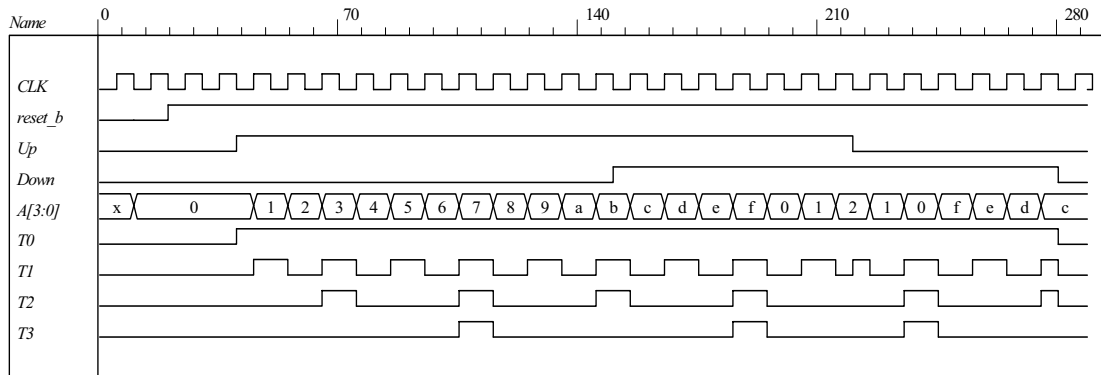

6.37

```

module Counter_if (output reg [3: 0] Count, input clock, reset);
always @ (posedge clock , posedge reset)
    if (reset)Count <= 0;
    else if (Count == 0) Count <= 1;
    else if (Count == 1) Count <= 3; // Default interpretation is decimal
    else if (Count == 3) Count <= 7;
    else if (Count == 4) Count <= 0;
    else if (Count == 6) Count <= 4;
    else if (Count == 7) Count <= 6;
    else Count <= 0;
endmodule

```

```

module Counter_case (output reg [3: 0] Count, input clock, reset);
always @ (posedge clock , posedge reset)
    if (reset)Count <= 0;
    else begin
        Count <= 0;
        case (Count)
            0: Count <= 1;
            1: Count <= 3;
            3: Count <= 7;
            4: Count <= 0;
            6: Count <= 4;
            7: Count <= 6;
        default: Count <= 0;
        endcase
    end
endmodule

```

```
end
endmodule
```

```
module Counter_FSM (output reg [3: 0] Count, input clock, reset);
reg [2: 0] state, next_state;
parameter s0 = 0, s1 = 1, s2 = 2, s3 = 3, s4 = 4, s5 = 5, s6 = 6, s7 = 7;
```

```
always @ (posedge clock , posedge reset)
if (reset) state <= s0; else state <= next_state;
```

```
always @ (state) begin
Count = 0;
case (state)
s0: begin next_state = s1; Count = 0; end
s1: begin next_state = s2; Count = 1; end
s2: begin next_state = s3; Count = 3; end
s3: begin next_state = s4; Count = 7; end
s4: begin next_state = s5; Count = 6; end
s5: begin next_state = s6; Count = 4; end
default: begin next_state = s0; Count = 0; end
endcase
end
endmodule
```

6.38 (a)

```
module Prob_6_38a_Updown (OUT, Up, Down, Load, IN, CLK); // Verilog 1995
```

```
output [3: 0] OUT;
input [3: 0] IN;
input Up, Down, Load, CLK;
reg [3:0] OUT;
```

```
always @ (posedge CLK)
if (Load) OUT <= IN;
else if (Up) OUT <= OUT + 4'b0001;
else if (Down) OUT <= OUT - 4'b0001;
else OUT <= OUT;
endmodule
```

```
module updown ( // Verilog 2001, 2005
```

```
output reg[3: 0] OUT,
input [3: 0] IN,
input Up, Down, Load, CLK
);
```

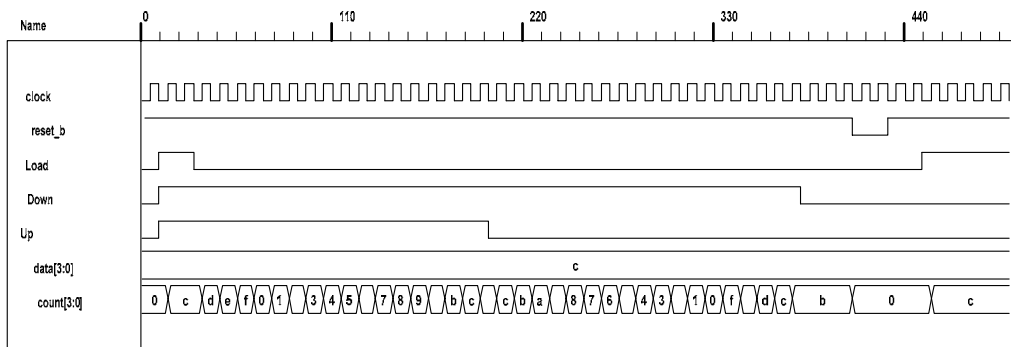

(b)



```
module Prob_6_38b_Updown (output reg [3: 0] OUT, input [3: 0] IN, input s1, s0, CLK);
```

```
always @ (posedge CLK)
case {s1, s0}
  2'b00: OUT <= OUT + 4'b0001;
  2'b01: OUT <= OUT - 4'b0001;
  2'b10: OUT <= IN;
  2'b11: OUT <= OUT;
endcase
endmodule
```

```
module t_Prob_6_38b_Updown ();
  wire [3: 0] OUT;
  reg [3: 0] IN;
  reg s1, s0, CLK;
  Prob_6_38b_Updown M0 (OUT, IN, s1, s0, CLK);
```

```
initial #150 $finish;
initial begin CLK = 0; forever #5 CLK = ~CLK; end
initial fork
  IN = 4'b1010;
```

```
#10 begin s1 = 1; s0 = 0; end // Load IN
#20 begin s1 = 1; s0 = 1; end // no change
#40 begin s1 = 0; s0 = 0; end // UP;
#80 begin s1 = 0; s0 = 1; end // DOWN
#120 begin s1 = 1; s0 = 1; end
join
endmodule
```

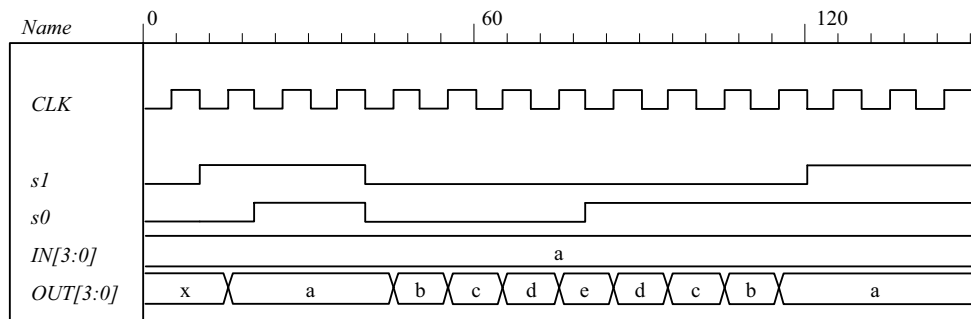

6.39

```
module Prob_6_39_Counter_BEH (output reg [2: 0] Count, input Clock, reset_b);
  always @ (posedge Clock, negedge reset_b) if (reset_b == 0) Count <= 0;
  else case (Count)
    0: Count <= 1;
    1: Count <= 2;
    2: Count <= 4;
    4: Count <= 5;
    5: Count <= 6;
    6: Count <= 0;
  endcase
endmodule
```

```
module Prob_6_39_Counter_STR (output [2: 0] Count, input Clock, reset_b);
  supply1 PWR;
  wire Count_1_b = ~Count[1];
```

```

JK_FF M2 (Count[2], Count[1], Count[1], Clock, reset_b);
JK_FF M1 (Count[1], Count[0], PWR, Clock, reset_b);
JK_FF M0 (Count[0], Count_1_b, PWR, Clock, reset_b);
endmodule

```

```

module JK_FF (output reg Q, input J, K, clk, reset_b);
always @ (posedge clk, negedge reset_b) if (reset_b == 0) Q <= 0; else
case ({J,K})
2'b00: Q <= Q;
2'b01: Q <= 0;
2'b10: Q <= 1;
2'b11: Q <= ~Q;
endcase
endmodule

```

```

module t_Prob_6_39_Counter ();
wire [2: 0] Count_BEH, Count_STR;
reg Clock, reset_b;

Prob_6_39_Counter_BEH M0_BEH (Count_STR, Clock, reset_b);
Prob_6_39_Counter_STR M0_STR (Count_BEH, Clock, reset_b);

initial #250 $finish;
initial fork #1 reset_b = 0; #7 reset_b = 1; join
initial begin Clock = 1; forever #5 Clock = ~Clock; end
endmodule

```

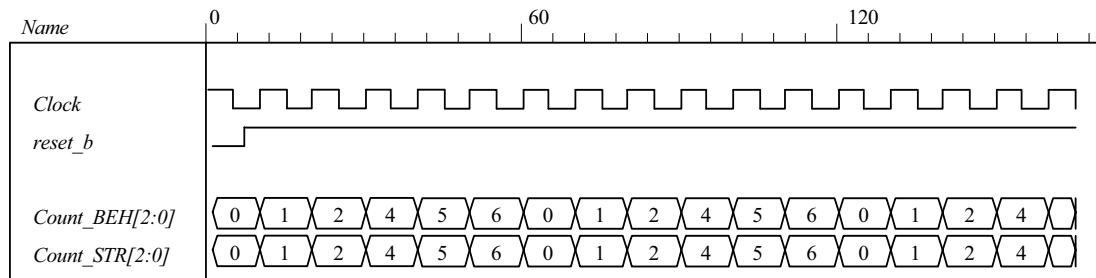

6.40

```

module Prob_6_40 (output reg [0: 7] timer, input clk, reset_b);

always @ (negedge clk, negedge reset_b)
if (reset_b == 0) timer <= 8'b1000_0000; else
case (timer)
8'b1000_0000: timer <= 8'b0100_0000;
8'b0100_0000: timer <= 8'b0010_0000;
8'b0010_0000: timer <= 8'b0001_0000;
8'b0001_0000: timer <= 8'b0000_1000;
8'b0000_1000: timer <= 8'b0000_0100;
8'b0000_0100: timer <= 8'b0000_0010;
8'b0000_0010: timer <= 8'b0000_0001;
8'b0000_0001: timer <= 8'b1000_0000;
default: timer <= 8'b1000_0000;
endcase
endmodule

module t_Prob_6_40 ();
wire [0: 7] timer;
reg clk, reset_b;

```

```

Prob_6_40 M0 (timer, clk, reset_b);

initial #250 $finish;
initial fork #1 reset_b = 0; #7 reset_b = 1; join
initial begin clk = 1; forever #5 clk = ~clk; end
endmodule

```

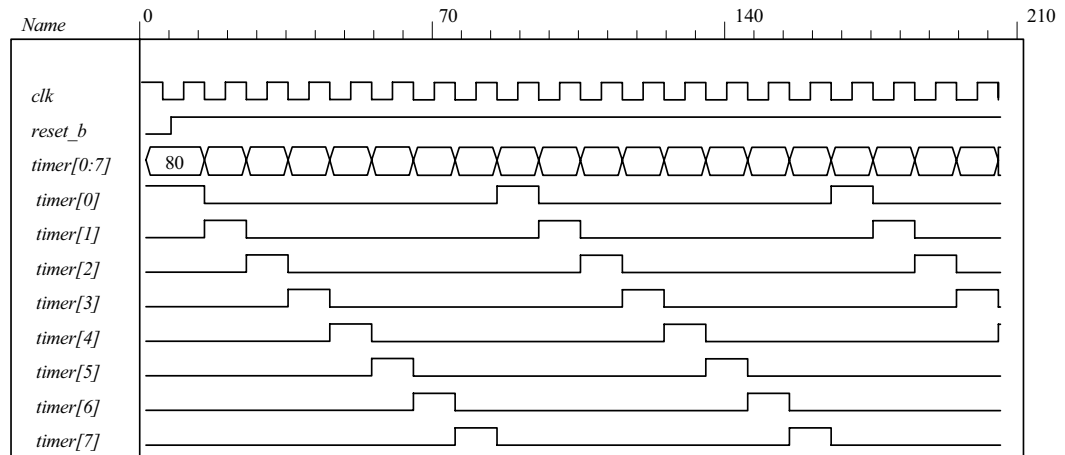

6.41

```

module Prob_6_41_Switched_Tail_Johnson_Counter (output [0: 3] Count, input CLK, reset_b);
wire Q_0b, Q_1b, Q_2b, Q_3b;

```

```

DFF M3 (Count[3], Q_3b, Count[2], CLK, reset_b);
DFF M2 (Count[2], Q_2b, Count[1], CLK, reset_b);
DFF M1 (Count[1], Q_1b, Count[0], CLK, reset_b);
DFF M0 (Count[0], Q_0b, Q_3b, CLK, reset_b);

```

**endmodule**

```

module DFF (output reg Q, output Q_b, input D, clk, reset_b);
assign Q_b = ~Q;
always @ (posedge clk, negedge reset_b) if (reset_b ==0) Q <= 0; else Q <= D;
endmodule

```

```

module t_Prob_6_41_Switched_Tail_Johnson_Counter ();
wire [3: 0] Count;
reg CLK, reset_b;
wire s0 = ~ M0.Count[0] && ~M0.Count[3];
wire s1 = M0.Count[0] && ~M0.Count[1];
wire s2 = M0.Count[1] && ~M0.Count[2];
wire s3 = M0.Count[2] && ~M0.Count[3];
wire s4 = M0.Count[0] && M0.Count[3];
wire s5 = ~ M0.Count[0] && M0.Count[1];
wire s6 = ~ M0.Count[1] && M0.Count[2];
wire s7 = ~ M0.Count[2] && M0.Count[3];

```

```

Prob_6_41_Switched_Tail_Johnson_Counter M0 (Count, CLK, reset_b);
initial #150 $finish;
initial fork #1 reset_b = 0; #7 reset_b = 1; join
initial begin CLK = 1; forever #5 CLK = ~CLK; end
endmodule

```

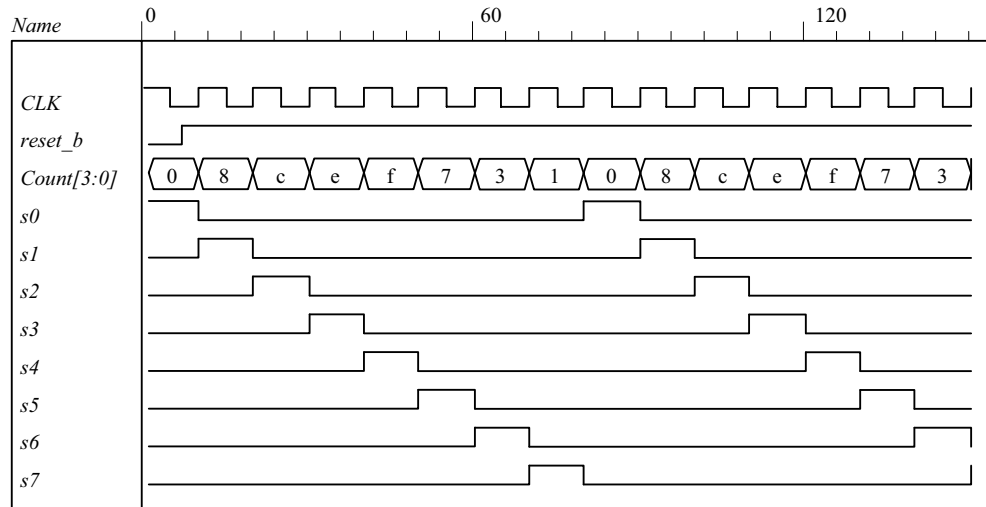

6.42 Because A is a register variable, it retains whatever value has been assigned to it until a new value is assigned. Therefore, the statement  $A \leq A$  has the same effect as if the statement was omitted.

6.43

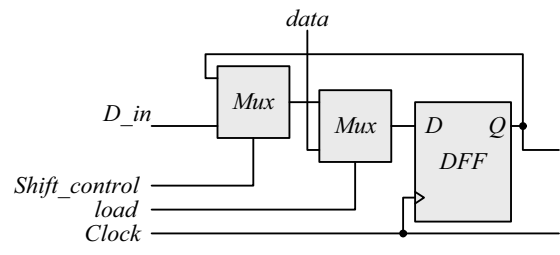

```

module Prob_6_43_Str (output SO, input [7: 0] data, input load, Shift_control, Clock, reset_b);
supply0 gnd;
wire SO_A;
    
```

```

    Shift_with_Load M_A (SO_A, SO_A, data, load, Shift_control, Clock, reset_b);
    Shift_with_Load M_B (SO, SO_A, data, gnd, Shift_control, Clock, reset_b);
    
```

**endmodule**

```

module Shift_with_Load (output SO, input D_in, input [7: 0] data, input load, select, Clock, reset_b);
wire [7: 0] Q;
assign SO = Q[0];
    SR_cell M7 (Q[7], D_in, data[7], load, select, Clock, reset_b);
    SR_cell M6 (Q[6], Q[7], data[6], load, select, Clock, reset_b);
    SR_cell M5 (Q[5], Q[6], data[5], load, select, Clock, reset_b);
    SR_cell M4 (Q[4], Q[5], data[4], load, select, Clock, reset_b);
    SR_cell M3 (Q[3], Q[4], data[3], load, select, Clock, reset_b);
    SR_cell M2 (Q[2], Q[3], data[2], load, select, Clock, reset_b);
    SR_cell M1 (Q[1], Q[2], data[1], load, select, Clock, reset_b);
    SR_cell M0 (Q[0], Q[1], data[0], load, select, Clock, reset_b);
    
```

**endmodule**

```

module SR_cell (output Q, input D, data, load, select, Clock, reset_b);
  wire y;
  DFF_with_load M0 (Q, y, data, load, Clock, reset_b);
  Mux_2 M1 (y, Q, D, select);

```

**endmodule**

```

module DFF_with_load (output reg Q, input D, data, load, Clock, reset_b);
  always @ (posedge Clock, negedge reset_b)
    if (reset_b == 0) Q <= 0; else if (load) Q <= data; else Q <= D;

```

**endmodule**

```

module Mux_2 (output reg y, input a, b, sel);
  always @ (a, b, sel) if (sel == 1) y = b; else y = a;

```

**endmodule**

```

module t_Fig_6_4_Str ();
  wire SO;
  reg load, Shift_control, Clock, reset_b;
  reg [7: 0] data, Serial_Data;

```

```

  Prob_6_43_Str M0 (SO, data, load, Shift_control, Clock, reset_b);

```

```

always @ (posedge Clock, negedge reset_b)
  if (reset_b == 0) Serial_Data <= 0;
  else if (Shift_control ) Serial_Data <= {M0.SO_A, Serial_Data [7: 1]};

```

```

initial #200 $finish;
initial begin Clock = 0; forever #5 Clock = ~Clock; end
initial begin #2 reset_b = 0; #4 reset_b = 1; end

```

```

initial fork
  data = 8'h5A;
  #20 load = 1;
  #30 load = 0;
  #50 Shift_control = 1;
  #50 begin repeat (9) @ (posedge Clock) ;
    Shift_control = 0;
  end

```

**join**  
**endmodule**

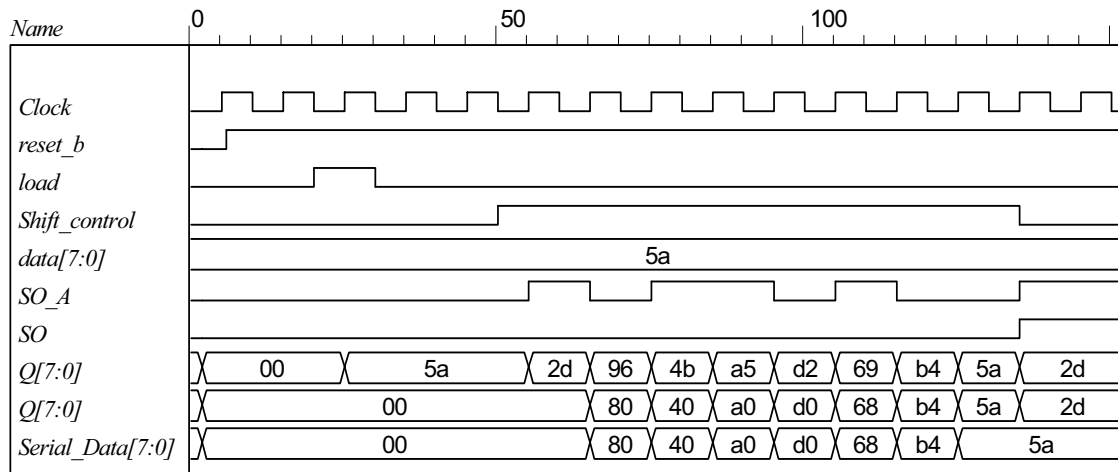

Alternative: a behavioral model for synthesis is given below. The behavioral description implies the need for a mux at the input to a D-type flip-flop.

```

module Fig_6_4_Beh (output SO, input [7: 0] data, input load, Shift_control, Clock, reset_b);
  reg [7: 0] Shift_Reg_A, Shift_Reg_B;
  assign SO = Shift_Reg_B[0];
  always @ (posedge Clock, negedge reset_b)
    if (reset_b == 0) begin
      Shift_Reg_A <= 0;
      Shift_Reg_B <= 0;
    end
    else if (load) Shift_Reg_A <= data;
    else if (Shift_control) begin
      Shift_Reg_A <= { Shift_Reg_A[0], Shift_Reg_A[7: 1]};
      Shift_Reg_B <= {Shift_Reg_A[0], Shift_Reg_B[7: 1]};
    end
  end

```

**endmodule**

```

module t_Fig_6_4_Beh ();
  wire SO;
  reg load, Shift_control, Clock, reset_b;
  reg [7: 0] data, Serial_Data;

```

Fig\_6\_4\_Beh M0 (SO, data, load, Shift\_control, Clock, reset\_b);

```

always @ (posedge Clock, negedge reset_b)
  if (reset_b == 0) Serial_Data <= 0;
  else if (Shift_control ) Serial_Data <= {M0.Shift_Reg_A[0], Serial_Data [7: 1]};

```

```

initial #200 $finish;
initial begin Clock = 0; forever #5 Clock = ~Clock; end
initial begin #2 reset_b = 0; #4 reset_b = 1; end

```

```

initial fork
  data = 8'h5A;
  #20 load = 1;
  #30 load = 0;
  #50 Shift_control = 1;
  #50 begin repeat (9) @ (posedge Clock) ;
    Shift_control = 0;
  end
join
endmodule

```

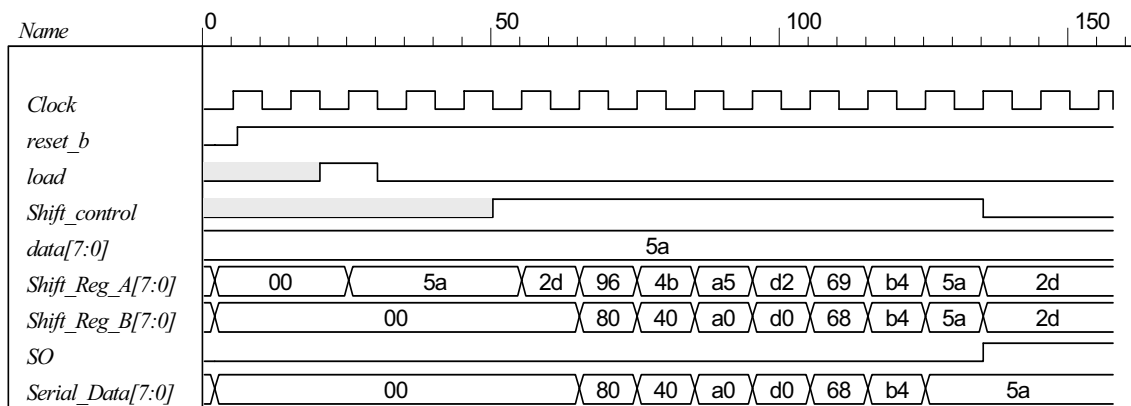

## 6.44

```
// See Figure 6.5
// Note: Sum is stored in shift register A; carry is stored in Q
// Note: Clear is active-low.

module Prob_6_44_Str (output SO, input [7: 0] data_A, data_B, input S_in, load, Shift_control, CLK,
    Clear);
    supply0 gnd;
    wire sum, carry;
    assign SO = sum;
    wire SO_A, SO_B;

    Shift_Reg_gated_clock M_A (SO_A, sum, data_A, load, Shift_control, CLK, Clear);
    Shift_Reg_gated_clock M_B (SO_B, S_in, data_B, load, Shift_control, CLK, Clear);
    FA M_FA (carry, sum, SO_A, SO_B, Q);
    DFF_gated M_FF (Q, carry, Shift_control, CLK, Clear);

endmodule

module Shift_Reg_gated_clock (output SO, input S_in, input [7: 0] data, input load, Shift_control,
    Clock, reset_b);
    reg [7: 0] SReg;
    assign SO = SReg[0];

    always @ (posedge Clock, negedge reset_b)
        if (reset_b == 0) SReg <= 0;
        else if (load) SReg <= data;
        else if (Shift_control) SReg <= {S_in, SReg[7: 1]};
endmodule

module DFF_gated (output Q, input D, Shift_control, Clock, reset_b);
    DFF M_DFF (Q, D_internal, Clock, reset_b);
    Mux_2 M_Mux (D_internal, Q, D, Shift_control);
endmodule

module DFF (output reg Q, input D, Clock, reset_b);
    always @ (posedge Clock, negedge reset_b)
        if (reset_b == 0) Q <= 0; else Q <= D;
endmodule

module Mux_2 (output reg y, input a, b, sel);
    always @ (a, b, sel) if (sel ==1) y = b; else y = a;
endmodule

module FA (output reg carry, sum, input a, b, C_in);
    always @ (a, b, C_in) {carry, sum} = a + b + C_in;
endmodule

module t_Prob_6_44_Str ();
    wire SO;
    reg SI, load, Shift_control, Clock, Clear;
    reg [7: 0] data_A, data_B;

    Prob_6_44_Str M0 (SO, data_A, data_B, SI, load, Shift_control, Clock, Clear);

    initial #200 $finish;
    initial begin Clock = 0; forever #5 Clock = ~Clock; end
    initial begin #2 Clear = 0; #4 Clear = 1; end
```

**initial fork**

```

data_A = 8'hAA; //8'h ff;
data_B = 8'h55; //8'h01;
SI = 0;
#20 load = 1;
#30 load = 0;
#50 Shift_control = 1;
#50 begin repeat (8) @ (posedge Clock) ;
    #5 Shift_control = 0;
end
join
endmodule
    
```

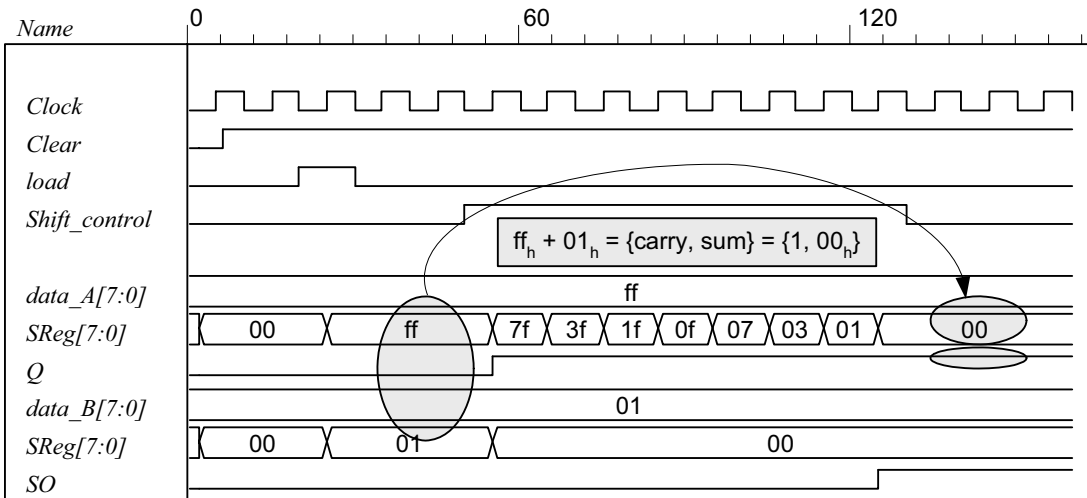
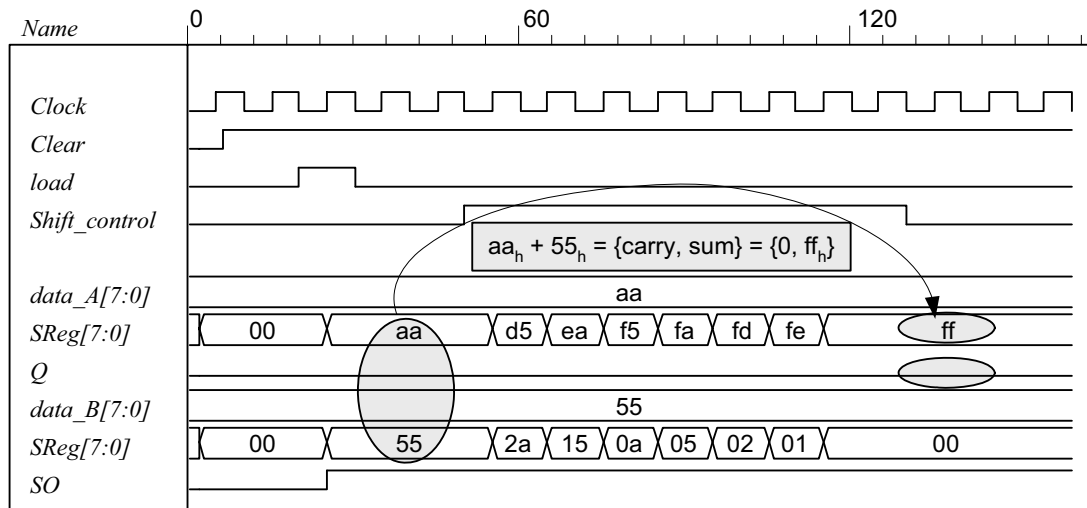

**6.45**

```

module Prob_6_45 (output reg y_out, input start, clock, reset_bar);
parameter s0 = 4'b0000,
s1 = 4'b0001,
s2 = 4'b0010,
s3 = 4'b0011,
s4 = 4'b0100,
s5 = 4'b0101,
    
```



```
s6 = 4'b0110,
s7 = 4'b0111,
s8 = 4'b1000;
reg [3: 0] state, next_state;

always @ (posedge clock, negedge reset_bar)
if (!reset_bar) state <= s0; else state <= next_state;

always @ (state, start) begin
y_out = 1'b0;
case (state)
s0: if (start) next_state = s1; else next_state = s0;
s1: begin next_state = s2; y_out = 1; end
s2: begin next_state = s3; y_out = 1; end
s3: begin next_state = s4; y_out = 1; end
s4: begin next_state = s5; y_out = 1; end
s5: begin next_state = s6; y_out = 1; end
s6: begin next_state = s7; y_out = 1; end
s7: begin next_state = s8; y_out = 1; end
s8: begin next_state = s0; y_out = 1; end
default: next_state = s0;
endcase
end
endmodule

// Test plan

// Verify the following:
// Power-up reset
// Response to start in initial state
// Reset on-the-fly
// Response to re-assertion of start after reset on-the-fly
// 8-cycle counting sequence
// Ignore start during counting sequence
// Return to initial state after 8 cycles and await start
// Remain in initial state for one clock if start is asserted when the state is entered

module t_Prob_6_45;
wire y_out;
reg start, clock, reset_bar;

Prob_6_45 M0 (y_out, start, clock, reset_bar);

initial #300 $finish;
initial begin clock = 0; forever #5 clock = ~clock; end
initial fork
reset_bar = 0;
#2 reset_bar = 1;
#10 start = 1;
#20 start = 0;
#30 reset_bar = 0;
#50 reset_bar = 1;
#80 start = 1;
#90 start = 0;
#130 start = 1;
#140 start = 0;
#180 start = 1;
join
endmodule
```

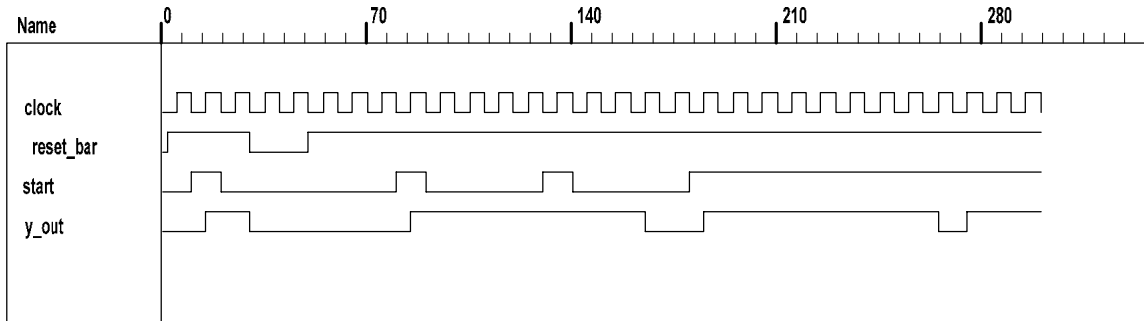

6.46

```
module Prob_6_46 (output reg [0: 3] timer, input clk, reset_b);
```

```
always @ (negedge clk, negedge reset_b)
if (reset_b == 0) timer <= 4'b1000; else
case (timer)
4'b1000: timer <= 4'b0100;
4'b0100: timer <= 4'b0010;
4'b0010: timer <= 4'b0001;
4'b0001: timer <= 4'b1000;
default: timer <= 4'b1000;
endcase
endmodule
```

```
module t_Prob_6_46 ();
wire [0: 3] timer;
reg clk, reset_b;
```

```
Prob_6_46 M0 (timer, clk, reset_b);
```

```
initial #150 $finish;
initial fork #1 reset_b = 0; #7 reset_b = 1; join
initial begin clk = 1; forever #5 clk = ~clk; end
endmodule
```

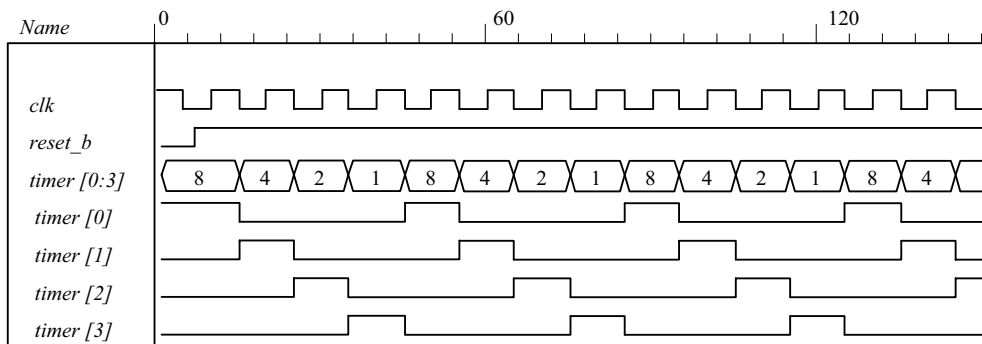

6.47

```
module Prob_6_47 (
output reg P_odd,
input D_in, CLK, reset
);
wire D;
```

```
assign D = D_in ^ P_odd;
always @ (posedge CLK, posedge reset)
```

```

    if (reset) P_odd <= 0;
    else P_odd <= D;
endmodule

module t_Prob_6_47 ();
wire P_odd;
reg D_in, CLK, reset;

Prob_6_47 M0 (P_odd, D_in, CLK, reset);

initial #150 $finish;
initial fork #1 reset = 1; #7 reset = 0; join
initial begin CLK = 0; forever #5 CLK = ~CLK; end
initial begin D_in = 1; forever #20 D_in = ~D_in; end
endmodule

```

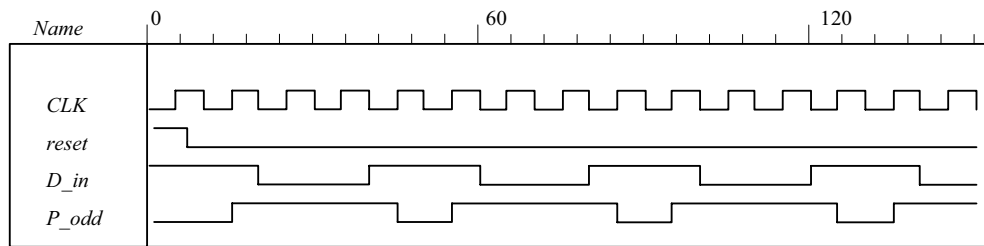

6.48 (a)

```

module Prob_6_48a (output reg [7: 0] count, input clk, reset_b);
reg [3: 0] state;
always @ (posedge clk, negedge reset_b)
if (reset_b == 0) state <= 0; else state <= state + 1;
always @ (state)
case (state)
0, 2, 4, 6, 8, 10, 12: count = 8'b0000_0001;
1: count = 8'b0000_0010;
3: count = 8'b0000_0100;
5: count = 8'b0000_1000;
7: count = 8'b0001_0000;
9: count = 8'b0010_0000;
11: count = 8'b0100_0000;
13: count = 8'b1000_0000;
default: count = 8'b0000_0000;
endcase
endmodule

module t_Prob_6_48a ();
wire [7: 0] count;
reg clk, reset_b;

Prob_6_48a M0 (count, clk, reset_b);

initial #200 $finish;
initial begin clk = 0; forever #5 clk = ~clk; end
initial begin reset_b = 0; #2 reset_b = 1; end
endmodule

```

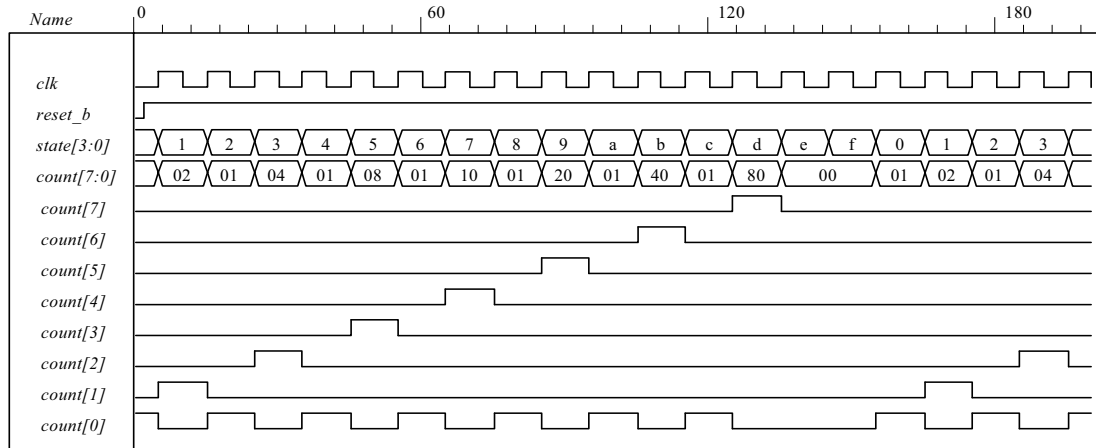

(b)

```

module Prob_6_48b (output reg [7: 0] count, input clk, reset_b);
  reg [3: 0] state;
  always @ (posedge clk, negedge reset_b)
    if (reset_b == 0) state <= 0; else state <= state + 1;
  always @ (state)
    case (state)
      0, 2, 4, 6, 8, 10, 12: count = 8'b1000_0000;
      1: count = 8'b0100_0000;
      3: count = 8'b0010_0000;
      5: count = 8'b0001_0000;
      7: count = 8'b0000_1000;
      9: count = 8'b0000_0100;
      11: count = 8'b0000_0010;
      13: count = 8'b0000_0001;
      default: count = 8'b0000_0000;
    endcase
endmodule

module t_Prob_6_48b ();
  wire [7: 0] count;
  reg clk, reset_b;

  Prob_6_48b M0 (count, clk, reset_b);

  initial #180 $finish;
  initial begin clk = 0; forever #5 clk = ~clk; end
  initial begin reset_b = 0; #2 reset_b = 1; end
endmodule

```

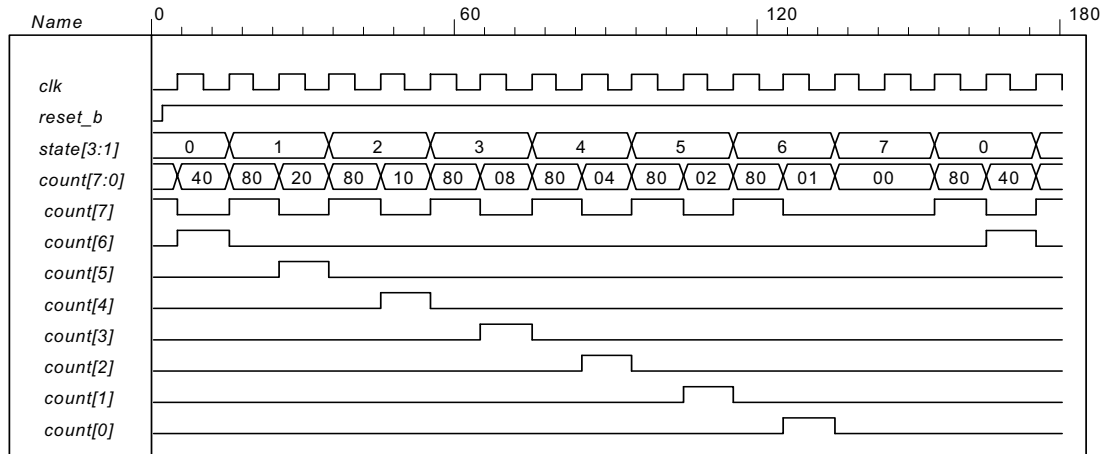

6.49

```
// Behavioral description of a 4-bit universal shift register
// Fig. 6.7 and Table 6.3
module Shift_Register_4_beh (           // V2001, 2005
  output reg [3: 0] A_par,           // Register output
  input      [3: 0] I_par,           // Parallel input
  input      s1, s0,                 // Select inputs
  MSB_in, LSB_in, // Serial inputs
  CLK, Clear    // Clock and Clear
);
always @ (posedge CLK, negedge Clear) // V2001, 2005
  if (~Clear) A_par <= 4'b0000;
  else
    case ({s1, s0})
      2'b00: A_par <= A_par;           // No change
      2'b01: A_par <= {MSB_in, A_par[3: 1]}; // Shift right
      2'b10: A_par <= {A_par[2: 0], LSB_in}; // Shift left
      2'b11: A_par <= I_par;           // Parallel load of input
    endcase
  endmodule
```

```
// Test plan:
// test reset action load
// test parallel load
// test shift right
// test shift left
// test circulation of data
// test reset on the fly

module t_Shift_Register_4_beh ();
  reg  s1, s0,          // Select inputs
      MSB_in, LSB_in, // Serial inputs
      clk, reset_b;    // Clock and Clear
  reg  [3: 0] l_par;    // Parallel input
  wire [3: 0] A_par;    // Register output

  Shift_Register_4_beh M0 (A_par, l_par, s1, s0, MSB_in, LSB_in, clk, reset_b);

  initial #200 $finish;
  initial begin clk = 0; forever #5 clk = ~clk; end

  initial fork
    // test reset action load
    #3 reset_b = 1;
    #4 reset_b = 0;
    #9 reset_b = 1;

    // test parallel load
    #10 l_par = 4'hA;
    #10 {s1, s0} = 2'b11;

    // test shift right
    #30 MSB_in = 1'b0;
    #30 {s1, s0} = 2'b01;

    // test shift left
    #80 LSB_in = 1'b1;
    #80 {s1, s0} = 2'b10;

    // test circulation of data
    #130 {s1, s0} = 2'b11;
    #140 {s1, s0} = 2'b00;

    // test reset on the fly

    #150 reset_b = 1'b0;
    #160 reset_b = 1'b1;
    #160 {s1, s0} = 2'b11;

  join
endmodule
```

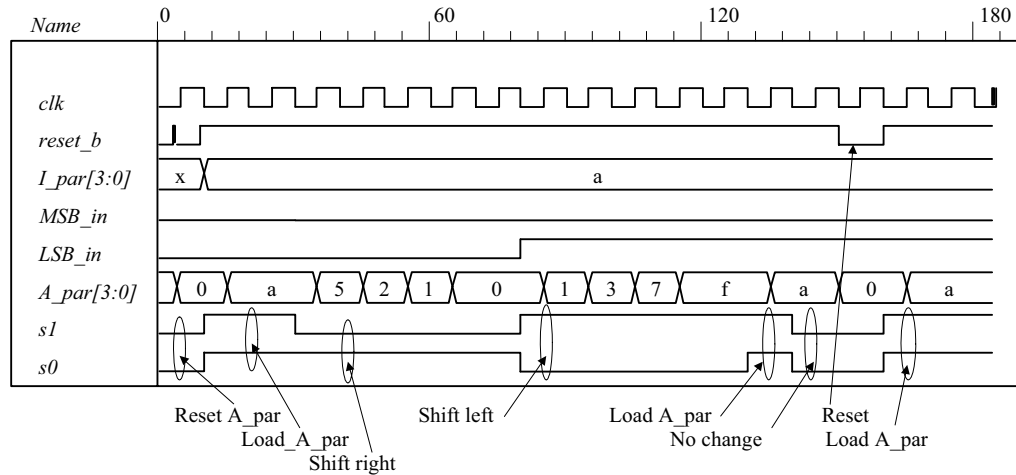

6.50 (a) See problem 6.27.

```

module Prob_8_50a (output reg [2: 0] count, input clk, reset_b);
always @ (posedge clk, negedge reset_b)
if (!reset_b) count <= 0;
else case (count)
  3'd0: count <= 3'd1;
  3'd1: count <= 3'd2;
  3'd2: count <= 3'd3;
  3'd3: count <= 3'd4;
  3'd4: count <= 3'd5;
  3'd5: count <= 3'd6;
  3'd6: count <= 3'd4;
  3'd7: count <= 3'd0;
default: count <= 3'd0;
endcase
endmodule

```

```

module t_Prob_8_50a;
wire [2: 0] count;
reg clock, reset_b ;

  Prob_8_50a M0 (count, clock, reset_b);

initial #130 $finish;
initial begin clock = 0; forever #5 clock = ~clock; end
initial fork
  reset_b = 0;
  #2 reset_b = 1;
  #40 reset_b = 0;
  #42 reset_b = 1;
join
endmodule

```

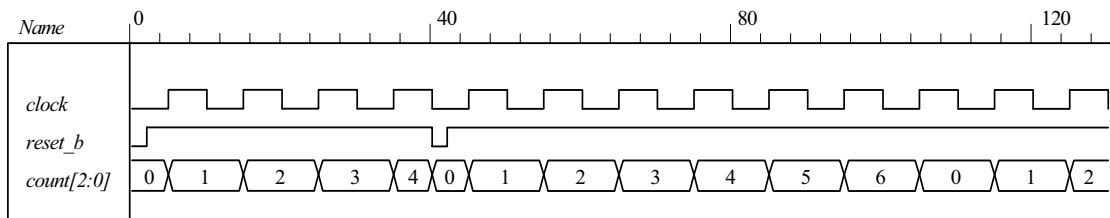

(b) See problem 6.28.

```

module Prob_8_50b (output reg [2: 0] count, input clk, reset_b);
always @ (posedge clk, negedge reset_b)
  if (!reset_b) count <= 0;
  else case (count)
    3'd0: count <= 3'd1;
    3'd1: count <= 3'd2;
    3'd2: count <= 3'd4;
    3'd4: count <= 3'd6;
    3'd6: count <= 3'd0;
    default: count <= 3'd0;
  endcase
endmodule

```

```

module t_Prob_8_50b;
wire [2: 0] count;
reg clock, reset_b ;

  Prob_8_50b M0 (count, clock, reset_b);

  initial #100 $finish;
  initial begin clock = 0; forever #5 clock = ~clock; end
  initial fork
    reset_b = 0;
    #2 reset_b = 1;
    #40 reset_b = 0;
    #42 reset_b = 1;
  join
endmodule

```

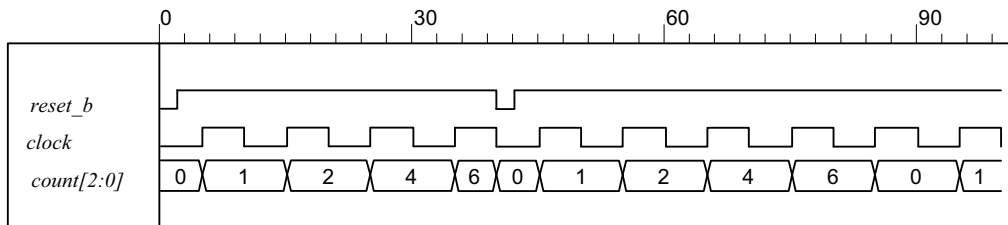

6.51

```

module Seq_Detector_Prob_5_51 (output detect, input bit_in, clk, reset_b);
  reg [2: 0] sample_reg;
  assign detect = (sample_reg == 3'b111);
  always @ (posedge clk, negedge reset_b) if (reset_b == 0) sample_reg <= 0;
  else sample_reg <= {bit_in, sample_reg [2: 1]};
endmodule

```

```

module Seq_Detector_Prob_5_45 (output detect, input bit_in, clk, reset_b);
  parameter S0 = 0, S1 = 1, S2 = 2, S3 = 3;
  reg [1: 0] state, next_state;

```

```

  assign detect = (state == S3);
  always @ (posedge clk, negedge reset_b)
  if (reset_b == 0) state <= S0; else state <= next_state;

```

```

  always @ (state, bit_in) begin
    next_state = S0;
    case (state)

```



```

0:   if (bit_in) next_state = S1; else state = S0;
1:   if (bit_in) next_state = S2; else next_state = S0;
2:   if (bit_in) next_state = S3; else state = S0;
3:   if (bit_in) next_state = S3; else next_state = S0;
default: next_state = S0;
endcase
end
endmodule

module t_Seq_Detector_Prob_6_51 ();
wire detect_45, detect_51;
reg bit_in, clk, reset_b;

Seq_Detector_Prob_5_51 M0 (detect_51, bit_in, clk, reset_b);
Seq_Detector_Prob_5_45 M1 (detect_45, bit_in, clk, reset_b);

initial #350$finish;
initial begin clk = 0; forever #5 clk = ~clk; end
initial fork

    reset_b = 0;
    #4 reset_b = 1;
    #10 bit_in = 1;
    #20 bit_in = 0;
    #30 bit_in = 1;
    #50 bit_in = 0;
    #60 bit_in = 1;
    #100 bit_in = 0;
join
endmodule

```

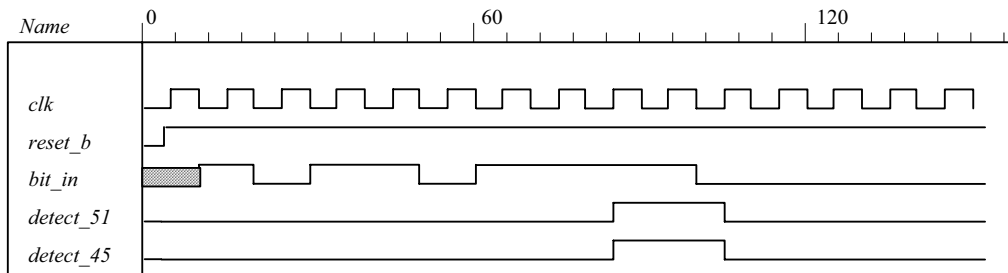

The circuit using a shift register uses less hardware.

## Chapter 7

- 7.1 (a)  $8\text{ K} \times 32 = 2^{13} \times 16$        $A = 13$      $D = 16$   
 (b)  $2\text{ G} \times 8 = 2^{31} \times 8$        $A = 31$      $D = 8$   
 (c)  $16\text{ M} \times 32 = 2^{24} \times 32$        $A = 24$      $D = 32$   
 (d)  $256\text{ K} \times 64 = 2^{18} \times 64$        $A = 18$      $D = 64$   
 (e)

- 7.2 (a)  $2^{13}$  (b)  $2^{31}$  (c)  $2^{26}$  (d)  $2^{21}$

- 7.3  $723 = 512 + 128 + 64 + 16 + 2 + 1$

$$3451 = 2048 + 1024 + 256 + 64 + 32 + 16 + 8 + 2 + 1$$

Address:  $10\ 1101\ 0011 = 2D3_{16}$

Data:  $0000\ 1101\ 0111\ 1011 = 0D7B_{16}$

- 7.4  $f_{\text{CPU}} = 100\text{ MHz}$ ,  $T_{\text{CPU}} = 1/f_{\text{CPU}} = 10^{-8}\text{ Hz}^{-1} = 10 \times 10^{-9}\text{ Hz}^{-1} = 10\text{ ns}$

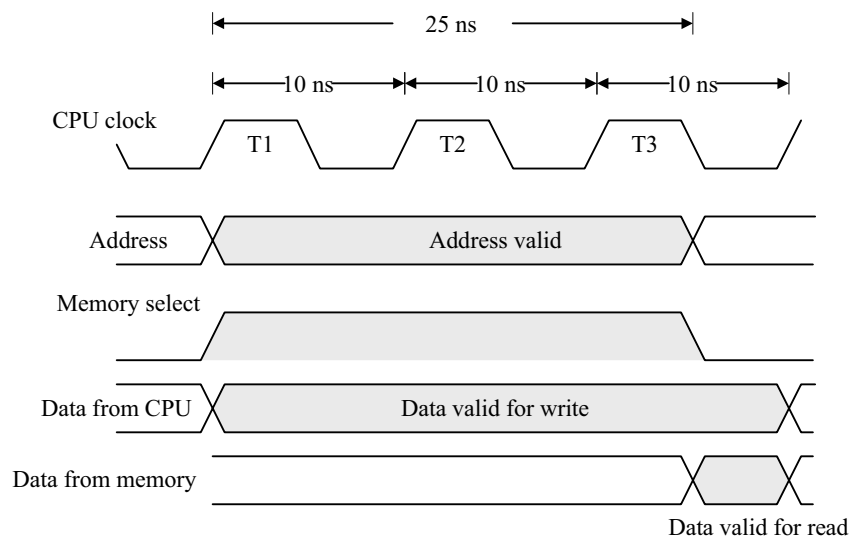

- 7.5

// Testing the memory of HDL Example 7.1.

```

module t_memory ();
    reg Enable, ReadWrite;
    reg [3: 0] DataIn;
    reg [5: 0] Address;
    wire [3: 0] DataOut;

    memory M0 (Enable, ReadWrite, Address, DataIn, DataOut);
    initial #200 $finish;
    initial begin
        Enable = 0; ReadWrite = 0; Address = 3; DataIn = 5;
        repeat (8) #5 Enable = ~Enable;
    end
    initial begin

```

```
#10 Address = 43; DataIn = 10;
#10 ReadWrite = 1;
#10 Address = 0;
end
initial
  $monitor ("E = %b RW = %b Add = %b D_in = %b D_out = %b T = %d",
    Enable, ReadWrite, Address, DataIn, DataOut, $time);

wire mem0 = M0.Mem[0];
wire mem1 =M0.Mem[1];
wire mem2 =M0.Mem[2];
wire mem3 =M0.Mem[3];
wire mem4 =M0.Mem[4];
wire mem5 =M0.Mem[5];
wire mem40 =M0.Mem[40];
wire mem41 =M0.Mem[41];
wire mem42 =M0.Mem[42];
wire mem43 =M0.Mem[43];
wire mem44 =M0.Mem[44];
wire mem45 =M0.Mem[45];
endmodule

//Read and write operations of Mem
//Mem size is 64 words of 4 bits each.
module memory (Enable, ReadWrite, Address, DataIn, DataOut);
  input Enable, ReadWrite;
  input [3: 0] DataIn;
  input [5: 0] Address;
  output [3:0] DataOut;
  reg [3: 0] DataOut;
  reg [3: 0] Mem [0: 63]; //64 x 4 Mem
  always @ (Enable or ReadWrite)
    if (Enable)
      if (ReadWrite) DataOut = Mem[Address]; //Read
      else Mem[Address] = DataIn; //Write
      else DataOut = 4'bz; //High impedance state
endmodule
```

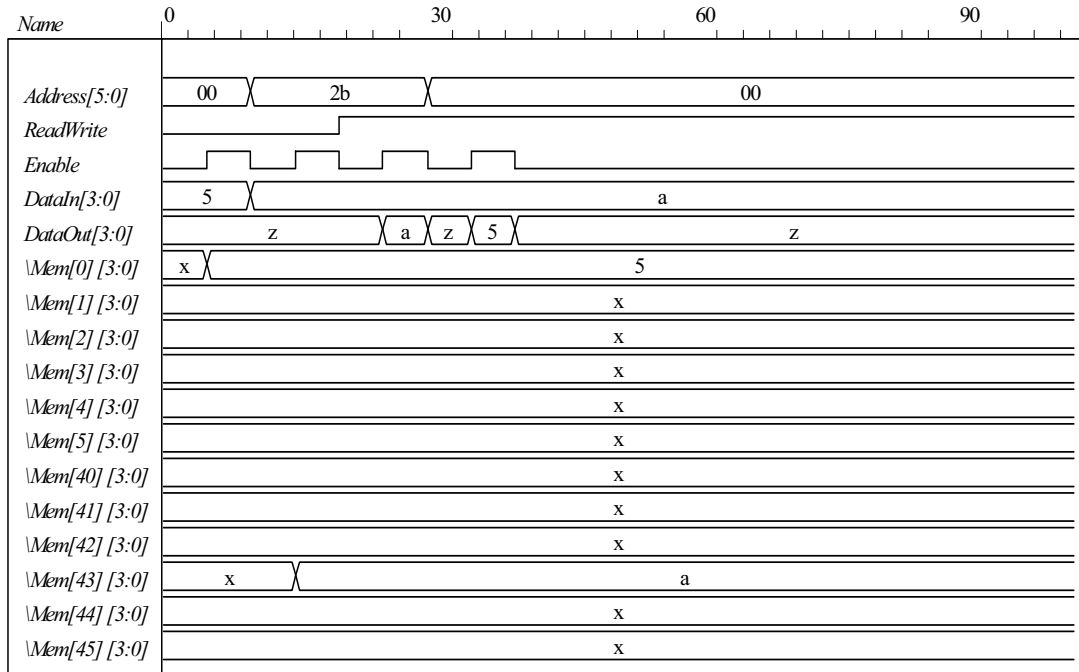

7.6

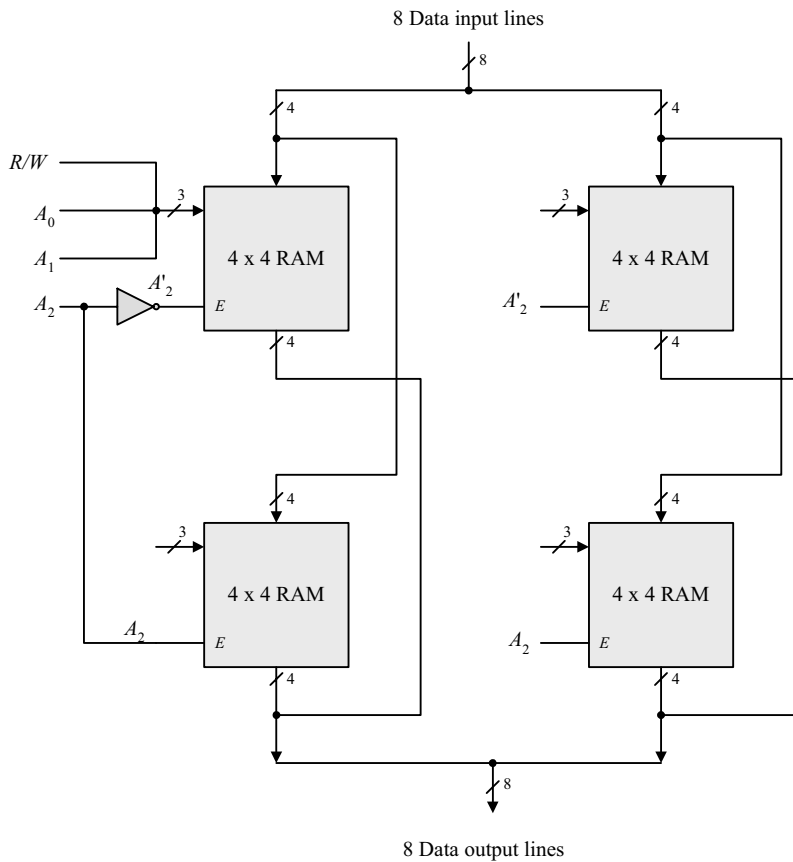

**7.7** (a)  $16\text{ K} = 2^{14} = 2^7 \times 2^7 = 128 \times 128$   
 Each decoder is  $7 \times 128$   
 Decoders require 256 AND gates, each with 7 inputs

(b)  $6,000 = 0101110\text{ }_x\text{ }1110000\text{ }_y$   
 $x = 46$   $y = 112$

**7.8** (a)  $256\text{ K} / 32\text{ K} = 8$  chips

(b)  $256\text{ K} = 2^{18}$  (18 address lines for memory);  $32\text{ K} = 2^{15}$  (15 address pins / chip)

(c)  $18 - 15 = 3$  lines ; must decode with  $3 \times 8$  decoder

**7.9**  $13 + 12 = 25$  address lines. Memory capacity =  $2^{25}$  words.

**7.10** 01011011 = 1 2 3 4 5 6 7 8 9 10 11 12 13  
 $P_1 P_2 0 P_4 1 0 1 P_8 1 0 1 1 P_{13}$

$P_1 = \text{Xor of bits (3, 5, 7, 9, 11)} = 0, 1, 1, 1, 1 = 0$  (Note: even # of 0s)

$P_2 = \text{Xor of bits (3, 6, 7, 10, 11)} = 0, 0, 1, 0, 1 = 0$

$P_4 = \text{Xor of bits (5, 6, 7, 12)} = 1, 0, 1, 1 = 1$  (Note: odd # of 0s)

$P_8 = \text{Xor of bits (9, 10, 11, 12)} = 1, 0, 1, 1 = 1$

Composite 13-bit code word: 0001 1011 1011 1

**7.11** 11001001010 = 1 2 3 4 5 6 7 8 9 10 11 12 13 14 15  
 $P_1 P_2 1 P_4 1 0 0 P_8 1 0 0 1 0 1 0$

$P_1 = \text{Xor of bits (3, 5, 7, 9, 11, 13, 15)} = 1, 1, 0, 1, 0, 0, 0 = 1$  (Note: odd # of 0s)

$P_2 = \text{Xor of bits (3, 6, 7, 10, 11, 14, 15)} = 1, 0, 0, 0, 0, 1, 0 = 0$  (Note: even # of 0s)

$P_4 = \text{Xor of bits (5, 6, 7, 12, 13, 14, 15)} = 1, 0, 0, 1, 0, 1, 0 = 1$

$P_8 = \text{Xor of bits (9, 10, 11, 12, 13, 14, 15)} = 1, 0, 0, 1, 0, 1, 0 = 1$

Composite 15-bit code word: 101 110 011 001 010

**7.12** (a) 1 2 3 4 5 6 7 8 9 10 11 12  
 0 0 0 0 1 1 1 0 1 0 1 0

$C_1 (1, 3, 5, 7, 9, 11) = 0, 0, 1, 1, 1, 1 = 0$

$C_2 (2, 3, 6, 7, 10, 11) = 0, 0, 1, 1, 0, 1 = 1$

$C_4 (4, 5, 6, 7, 12) = 0, 1, 1, 1, 0 = 1$

$C_8 (8, 9, 10, 11, 12) = 0, 1, 0, 1, 0 = 0$

$C = 0110$

Error in bit 6.

Correct data: 0101 1010

(b) 1 2 3 4 5 6 7 8 9 10 11 12  
 1 0 1 1 1 0 0 0 0 1 1 0

$C_1 (1, 3, 5, 7, 9, 11) = 1, 1, 1, 0, 0, 1 = 0$

$C_2 (2, 3, 6, 7, 10, 11) = 0, 1, 0, 0, 1, 1 = 1$

$C_4 (4, 5, 6, 7, 12) = 1, 1, 0, 0, 0 = 0$

$C_8 (8, 9, 10, 11, 12) = 0, 0, 1, 1, 0 = 0$

$$C = 0010$$

Error in bit 2 = Parity bit  $P_2$ .

	3	5	6	7	9	10	11	12
Correct 8-bit data:	1	1	0	0	0	1	1	0

(c) 

1	2	3	4	5	6	7	8	9	10	11	12
1	0	1	1	1	1	1	1	0	1	0	0

$C = 0000$  )No errors)

$$C_1 (1, 3, 5, 7, 9, 11) = 1, 1, 1, 0, 0, 1 = 0$$

$$C_2 (2, 3, 6, 7, 10, 11) = 0, 1, 0, 0, 1, 1 = 1$$

$$C_4 (4, 5, 6, 7, 12) = 1, 1, 0, 0, 0 = 0$$

$$C_8 (8, 9, 10, 11, 12) = 0, 0, 1, 1, 0 = 0$$

	3	5	6	7	9	10	11	12
Correct 8-bit data:	1	1	1	1	0	1	0	0

**7.13** (a) 16-bit data (From Table 7.2): 5 Check bits  
1 bit

-----  
6 parity bits

(b) 32-bit data (From Table 7.2): 6 Check bits  
1 bit

-----  
7 parity bits

(c) 16-bit data (From Table 7.2): 5 Check bits  
1 bit

-----  
6 parity bits

**7.14** (a) 

1	2	3	4	5	6	7	$P_1 = \text{Xor}(3, 5, 7) = 0, 0, 0 = 1$
$P_1$	$P_2$	0	$P_4$	0	1	0	$P_2 = \text{Xor}(3, 6, 7) = 0, 1, 0 = 0$
							$P_4 = \text{Xor}(5, 6, 7) = 0, 1, 0 = 1$

7-bit word: 0101010

(b) No error:

$$C_1 = \text{Xor}(1, 3, 5, 7) = 0, 0, 0, 0 = 0$$

$$C_2 = \text{Xor}(2, 3, 6, 7) = 1, 0, 1, 0 = 0$$

$$C_4 = \text{Xor}(4, 5, 6, 7) = 1, 0, 1, 0 = 0$$

(c) Error in bit 5: 

1	2	3	4	5	6	7
0	1	0	1	1	1	0

$$C_1 = \text{Xor}(0, 0, 1, 0) = 1$$

$$C_2 = \text{Xor}(1, 0, 1, 0) = 0$$

$$C_4 = \text{Xor}(1, 1, 1, 0) = 1$$

Error in bit 5:  $C = 101$

(d) 8-bit word            1 2 3 4 5 6 7 8  
                               0 1 0 1 0 1 0 1  
 Error in bits 2 and 5: 0 0 0 1 1 1 0 1  
 $C_1 = \text{Xor}(0, 0, 1, 0) = 1$   
 $C_2 = \text{Xor}(0, 0, 1, 0) = 1$   
 $C_4 = \text{Xor}(1, 1, 1, 0) = 1$   
 $P = 0$   
 $C = (1, 1, 1) \neq 0$  and  $P = 0$  indicates double error.

7.15

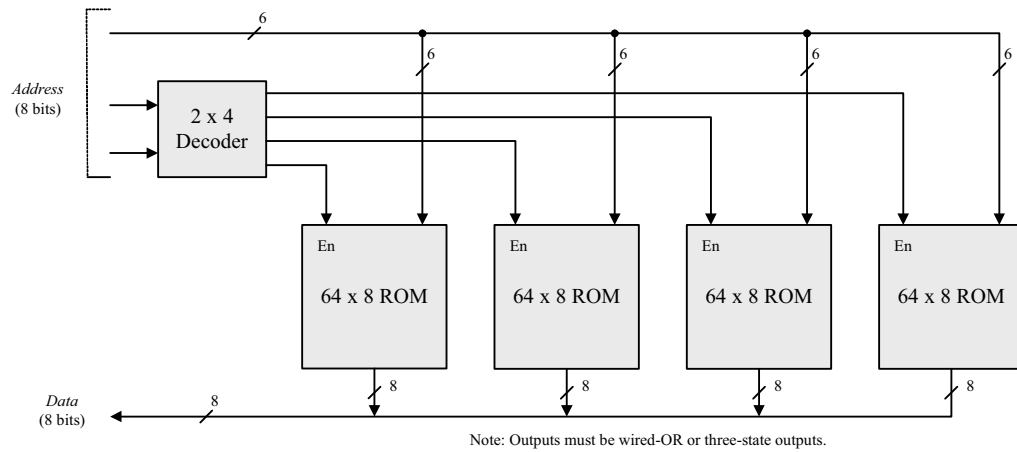

7.16

Note:  $4096 = 2^{12}$



16 inputs + 8 outputs requires a 24-pin IC.

7.18 (a)  $256 \times 8$  (b)  $512 \times 5$  (c)  $1024 \times 4$  (d)  $32 \times 7$

7.17

Input Address	Output of ROM			
	$D_6D_5D_4$	$D_3D_2D_1$	$D_0 (2^0)$	Decimal
00000	000	000	0, 1	0, 1
00001	000	001	0, 1	2, 3
...	...	...	...	...
01000	001	011	0, 1	16, 17
01001	001	100	0, 1	18, 19
...	...	...	...	...
...	...	...	...	...
11110	110	000	0, 1	60, 61
11111	110	001	0, 1	62, 63

7.18 (a) 8 inputs 8 outputs  $2^8 \times 8$  256 x 8 ROM

(b) 9 inputs 5 outputs  $2^9 \times 5$  512 x 5 ROM

(c) 10 inputs 4 outputs  $2^{10} \times 4$  1024 x 4 ROM

(d) 5 inputs 7 outputs  $2^5 \times 7$  32 x 7 ROM

7.19

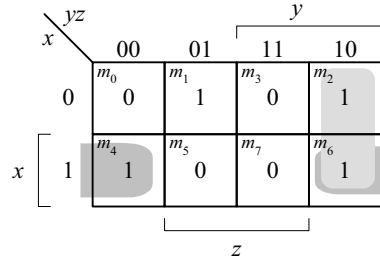

$$A = yz' + xz' + x'y'z$$

$$A' = yz + xz + x'y'z'$$

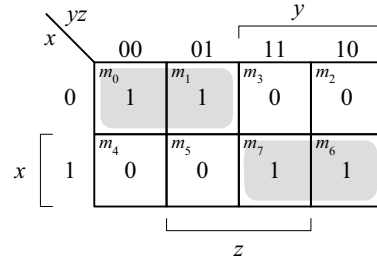

$$B = xy + x'y'$$

$$B' = x'y' + x'y$$

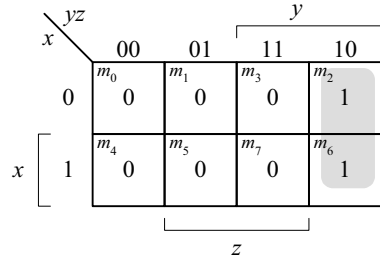

$$C = yz'$$

$$C' = y' + z$$

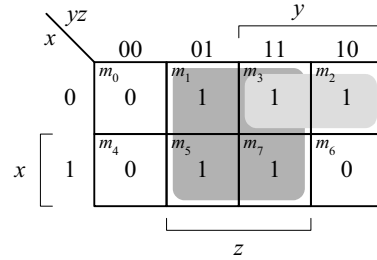

$$D = z + x'y$$

$$D' = y'z' + xz'$$

Product term	Inputs			Outputs			
	x	y	z	A	B	C	D
yz'	1	-	0	1	-	1	-
xz'	2	1	-	1	-	-	-
x'y'z	3	0	0	1	-	-	-
xy'	4	1	0	-	1	-	-
x'y	5	0	1	-	1	-	1
z	6	-	-	-	-	-	1

T C T T

7.20

Inputs	Outputs	
x y z	A, B, C, D	
0 0 0	1 1 0 1	
0 0 1	0 1 1 1	M[001] = 0111
0 1 0	0 0 0 0	
0 1 1	1 0 0 0	
1 0 0	1 0 0 1	M[100] = 1001
1 0 1	0 0 1 1	
1 1 0	1 1 0 0	
1 1 1	0 1 0 1	



7.21 Note: See truth table in Fig. 7.12(b).

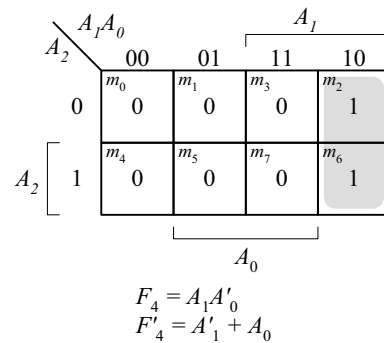
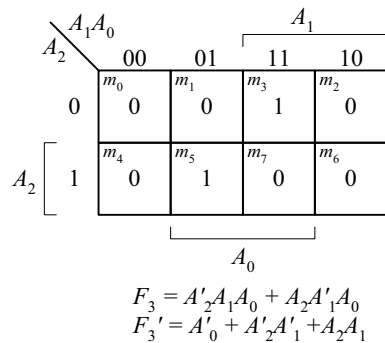
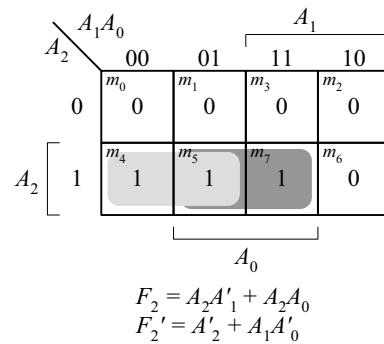
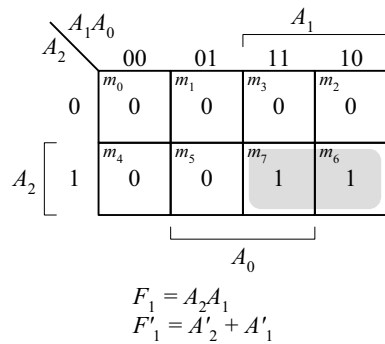

Product term	Inputs			Outputs			
	$A_2$	$A_1$	$A_0$	$F_1$	$F_2$	$F_3$	$F_4$
$A_2 A_1$	1	1	-	1	-	-	-
$A_2'$	0	-	-	-	1	-	-
$A_1 A_0'$	-	1	0	-	1	-	1
$A_2' A_1 A_0$	0	1	1	-	-	1	-
$A_2 A_1'$	1	0	1	-	-	1	-

T C T T

Alternative:  $F_1', F_2', F_3, F_4$   
(5 terms)

7.22

Decimal	w	x	y	z	$b_7$	$b_6$	$b_5$	$b_4$	$b_3$	$b_2$	$b_1$	$b_0$
0	0	0	0	0	0	0	0	0	0	0	0	0
1	1	0	0	0	1	0	0	0	0	0	0	1
2	4	0	0	1	0	0	0	0	0	1	0	0
3	9	0	0	1	1	0	0	0	0	1	0	1
4	16	0	1	0	0	0	0	1	0	0	0	0
5	25	0	1	0	1	0	0	1	1	0	0	1
6	36	0	1	1	0	0	1	0	0	1	0	0
7	49	0	1	1	1	0	0	1	1	0	0	1
8	64	1	0	0	0	0	1	0	0	0	0	0
9	81	1	0	0	1	0	1	0	0	0	0	1
10	100	1	0	1	0	0	1	1	0	0	1	0
11	121	1	0	1	1	0	1	1	1	0	0	1
12	144	1	1	0	0	1	0	0	1	0	0	0
13	169	1	1	0	1	1	0	1	0	1	0	0
14	196	1	1	1	0	1	1	0	0	0	1	0
15	225	1	1	1	1	1	1	0	0	0	0	1

Note:  $b_0 = z$ , and  $b_1 = 0$ .  
ROM would have 4 inputs  
and 6 outputs. A 4 x 8  
ROM would waste two  
outputs.

		y			
	yz	00	01	11	10
wx	00	$m_0$	$m_1$	$m_3$	$m_2$
	01	$m_4$	$m_5$	$m_7$	$m_6$
	11	$m_{12}$	$m_{13}$	$m_{15}$	$m_{14}$
w	10	$m_8$	$m_9$	$m_{11}$	$m_{10}$

$$b_2 = yx'$$

		y			
	yz	00	01	11	10
wx	00	$m_0$	$m_1$	$m_3$	$m_2$
	01	$m_4$	$m_5$	$m_7$	$m_6$
	11	$m_{12}$	$m_{13}$	$m_{15}$	$m_{14}$
w	10	$m_8$	$m_9$	$m_{11}$	$m_{10}$

$$b_3 = xy'z + x'yz$$

		y			
	yz	00	01	11	10
wx	00	$m_0$	$m_1$	$m_3$	$m_2$
	01	$m_4$	$m_5$	$m_7$	$m_6$
	11	$m_{12}$	$m_{13}$	$m_{15}$	$m_{14}$
w	10	$m_8$	$m_9$	$m_{11}$	$m_{10}$

$$b_4 = w'xz + xy'z' + wx'z$$

		y			
	yz	00	01	11	10
wx	00	$m_0$	$m_1$	$m_3$	$m_2$
	01	$m_4$	$m_5$	$m_7$	$m_6$
	11	$m_{12}$	$m_{13}$	$m_{15}$	$m_{14}$
w	10	$m_8$	$m_9$	$m_{11}$	$m_{10}$

$$b_5 = w'xy + wxz + wx'y$$

		y			
	yz	00	01	11	10
wx	00	$m_0$	$m_1$	$m_3$	$m_2$
	01	$m_4$	$m_5$	$m_7$	$m_6$
	11	$m_{12}$	$m_{13}$	$m_{15}$	$m_{14}$
w	10	$m_8$	$m_9$	$m_{11}$	$m_{10}$

$$b_6 = wy + wx'$$

		y			
	yz	00	01	11	10
wx	00	$m_0$	$m_1$	$m_3$	$m_2$
	01	$m_4$	$m_5$	$m_7$	$m_6$
	11	$m_{12}$	$m_{13}$	$m_{15}$	$m_{14}$
w	10	$m_8$	$m_9$	$m_{11}$	$m_{10}$

$$b_7 = wx$$

7.23

From Fig. 4-3:

$w = A + BC + BD$   
 $w' = A'B' + A'C'D'$   
 $x = B'C + B'D + BC'D'$   
 $x' = B'C'D' + BC BD$   
 $y = CD + C'D'$   
 $y' = C'D + CD'$   
 $z = D'$   
 $z' = D$   
 Use  $w, x', y, z$  (7 terms)

Product term	Inputs				Outputs			
	<i>A</i>	<i>B</i>	<i>C</i>	<i>D</i>	<i>F</i> <sub>1</sub>	<i>F</i> <sub>2</sub>	<i>F</i> <sub>3</sub>	<i>F</i> <sub>4</sub>
<i>A</i>	1	1	-	-	1	-	-	-
<i>BC</i>	2	-	1	1	1	1	-	-
<i>BD</i>	3	-	1	-	1	1	-	-
<i>B'C'D'</i>	4	-	0	0	0	-	1	-
<i>CD</i>	5	-	-	1	1	-	-	1
<i>C'D'</i>	6	-	-	0	0	-	-	1
<i>D'</i>	7	-	-	-	0	-	-	-
					T	C	T	T

7.24

AND					
Product term	Inputs				Outputs
	<i>A</i>	<i>B</i>	<i>C</i>	<i>D</i>	
1	1	-	-	-	$w = A + BC + BD$
2	-	1	1	-	
3	-	1	-	1	
4	-	0	1	-	$x = B'C + B'D + BC'D'$
5	-	0	-	1	
6	-	1	0	0	
7	-	-	1	1	$y = CD + C'D'$
8	-	-	0	0	
9	-	-	-	-	
10	-	-	-	0	$z = D'$
11	-	-	-	-	
12	-	-	-	-	

7.25

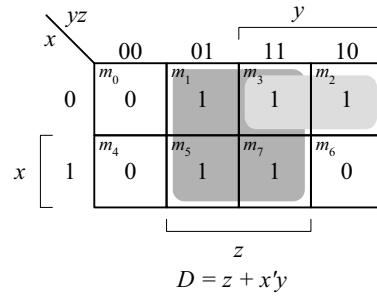
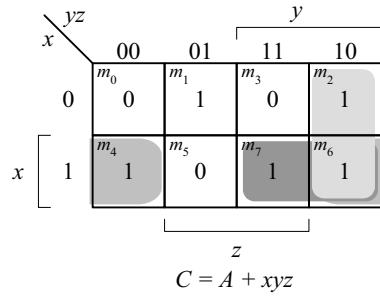
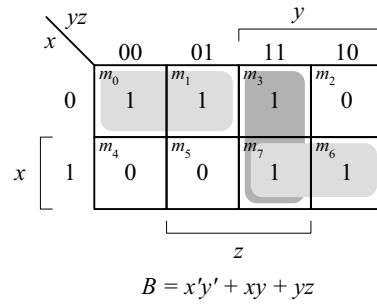
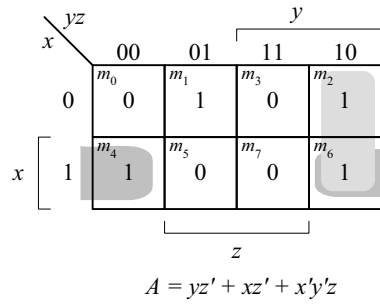

AND

Product term	Inputs x y z	Outputs A
1	- 1 0 -	$A = yz' + xz' + x'y'z$
2	1 - 0 -	
3	0 0 1 -	
4	0 0 - -	$B = x'y' + xy + yz$
5	1 1 - -	
6	0 1 1 -	
7	0 - - 1	$C = A + xyz$
8	1 1 1 -	
9	0 - - -	
10	0 - 1 -	$D = z + x'y$
11	0 1 - -	
12	- - - -	

$A = yz' + xz' + x'y'z$   
 $B = x'y' + xy + yz$   
 $C = A + xyz$   
 $D = z + x'y$

7.26

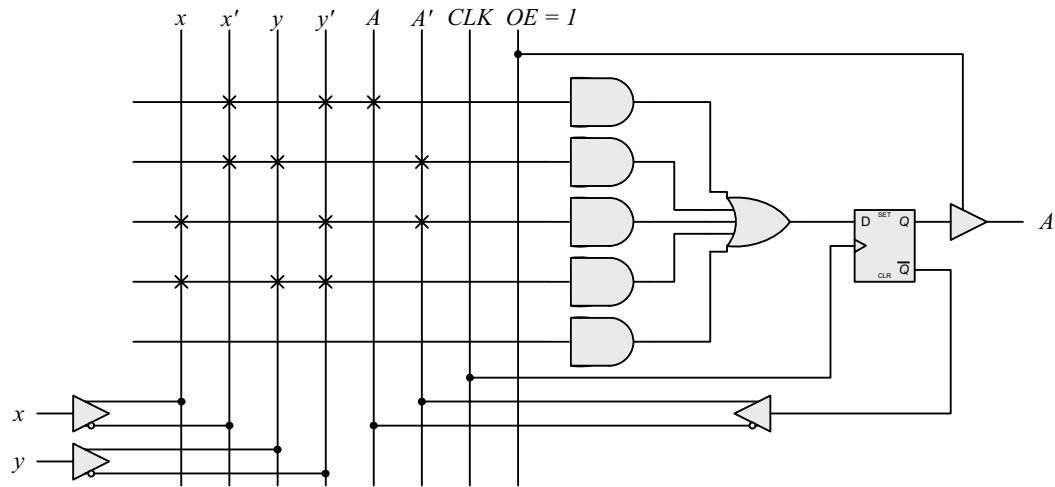

7.27

The results of Prob. 6.17 can be used to develop the equations for a three-bit binary counter with D-type flip-flops.

$$DA_0 = A'_0$$

$$DA_1 = A'_1A_0 + A_1A'_0$$

$$DA_2 = A'_2A_1A_0 + A_2A'_1 + A_2A'_0$$

$$C_{out} = A_2A_1A_0$$

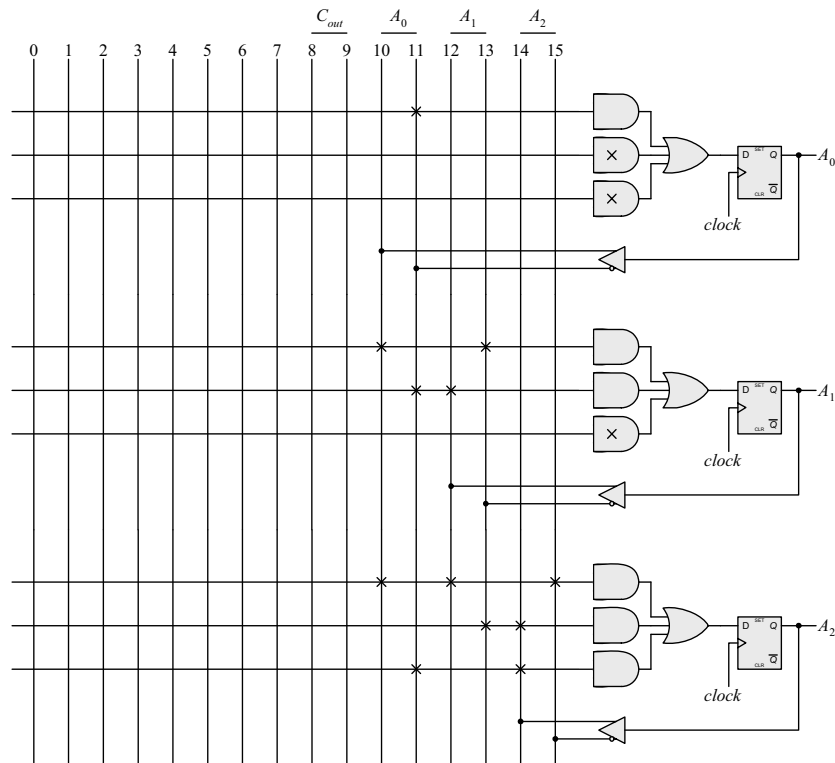

7.28

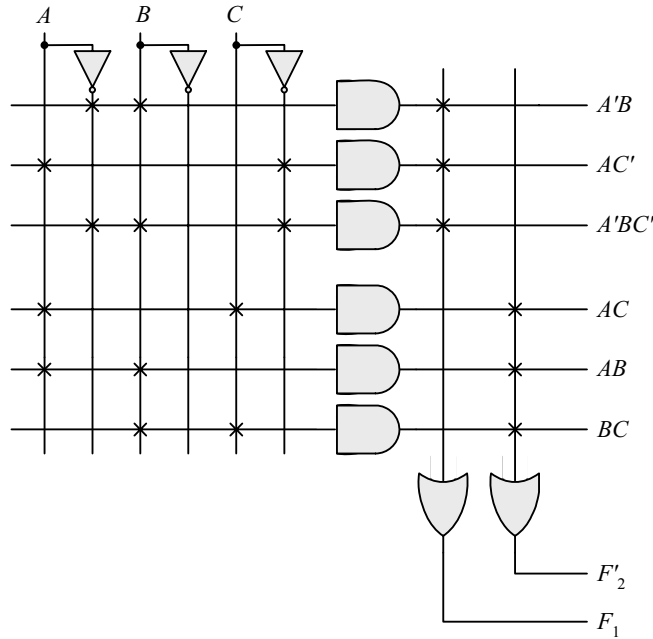

7.29

Product term	Inputs	Output
	$x y A$	$D_A$
$x'y'A$	1 0 0 1	1
$x'yA'$	2 0 1 0	1
$xy'A'$	3 1 0 0	1
$xyA$	4 1 1 1	1

## CHAPTER 8

- 8.1**
- (a) The transfer and increment occur concurrently, i.e., at the same clock edge. After the transfer,  $R2$  holds the contents that were in  $R1$  before the clock edge, and  $R2$  holds its previous value incremented by 1.
  - (b) Decrement the content of  $R3$  by one.
  - (c) If ( $S_1 = 1$ ), transfer content of  $R1$  to  $R0$ . If ( $S_1 = 0$  and  $S_2 = 1$ ), transfer content of  $R2$  to  $R0$ .

**8.2**

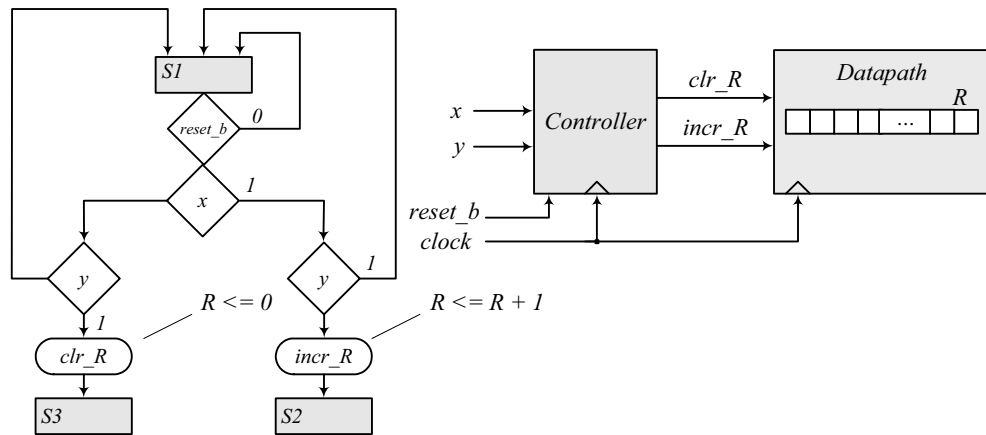

**8.3**

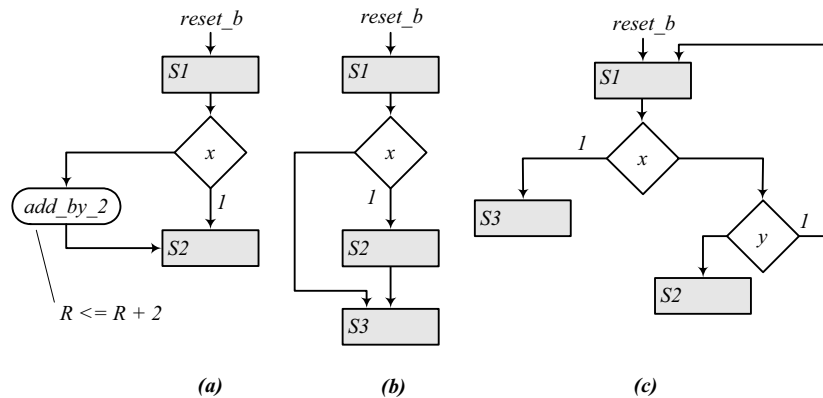

**8.4**

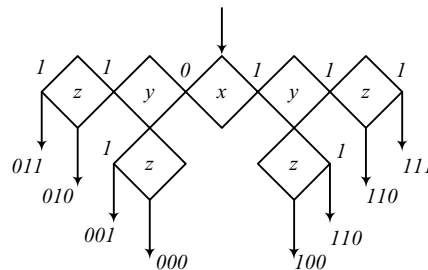

- 8.5**
- The operations specified in a flowchart are executed sequentially, one at a time. The operations specified in an ASM chart are executed concurrently for each ASM block. Thus, the operations listed within a state box, the operations specified by a conditional box, and the transfer to the next state in each ASM block are executed at the same clock edge. For example, in Fig. 8.5 with  $Start = 1$  and  $Flag = 1$ , signal  $Flush_R$  is asserted. At the clock edge the state moves to  $S_2$ , and register  $R$  is flushed.

8.6

Note: In practice, the asynchronous inputs  $x$  and  $y$  should be synchronized to the clock to avoid metastable conditions in the flip-flops..

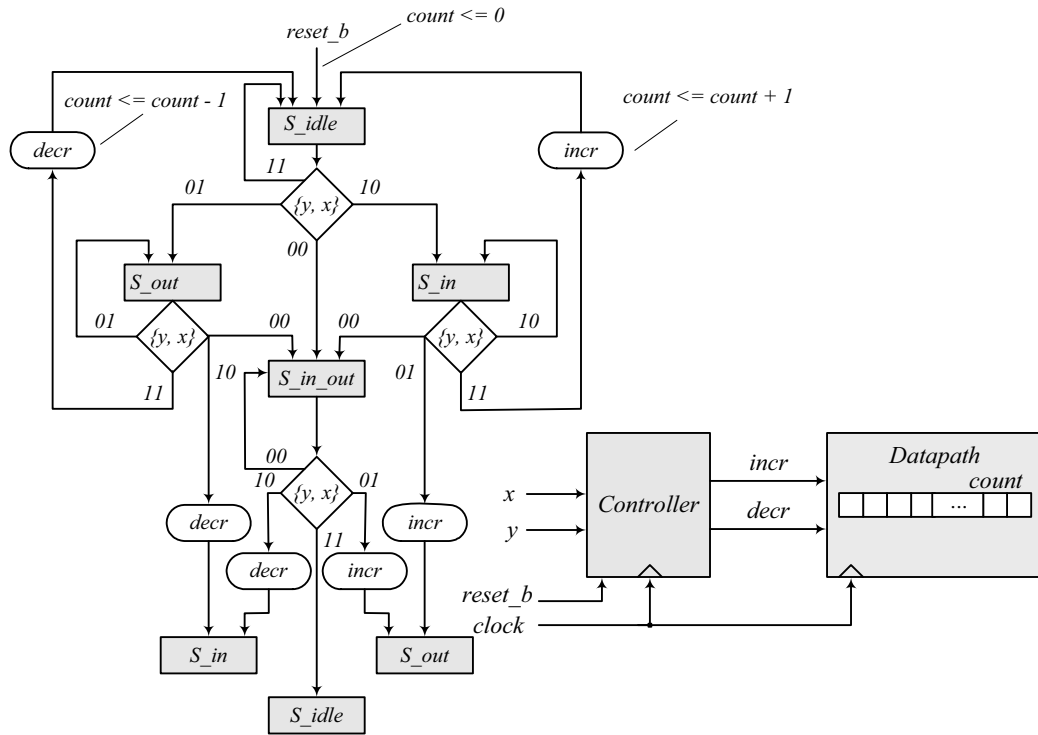

Note: To avoid counting a person more than once, the machine waits until  $x$  or  $y$  is de-asserted before incrementing or decrementing the counter. The machine also accounts for persons entering and leaving simultaneously.

8.7

RTL notation:

$S0$ : Initial state: if (start = 1) then ( $RA \leftarrow data\_A$ ,  $RB \leftarrow data\_B$ , go to  $S1$ ).

$S1$ :  $\{Carry, RA\} \leftarrow RA + (2's \text{ complement of } RB)$ , go to  $S2$ .

$S2$ : If (borrow = 0) go to  $S0$ . If (borrow = 1) then  $RA \leftarrow (2's \text{ complement of } RA)$ , go to  $S0$ .

Block diagram and ASMD chart:



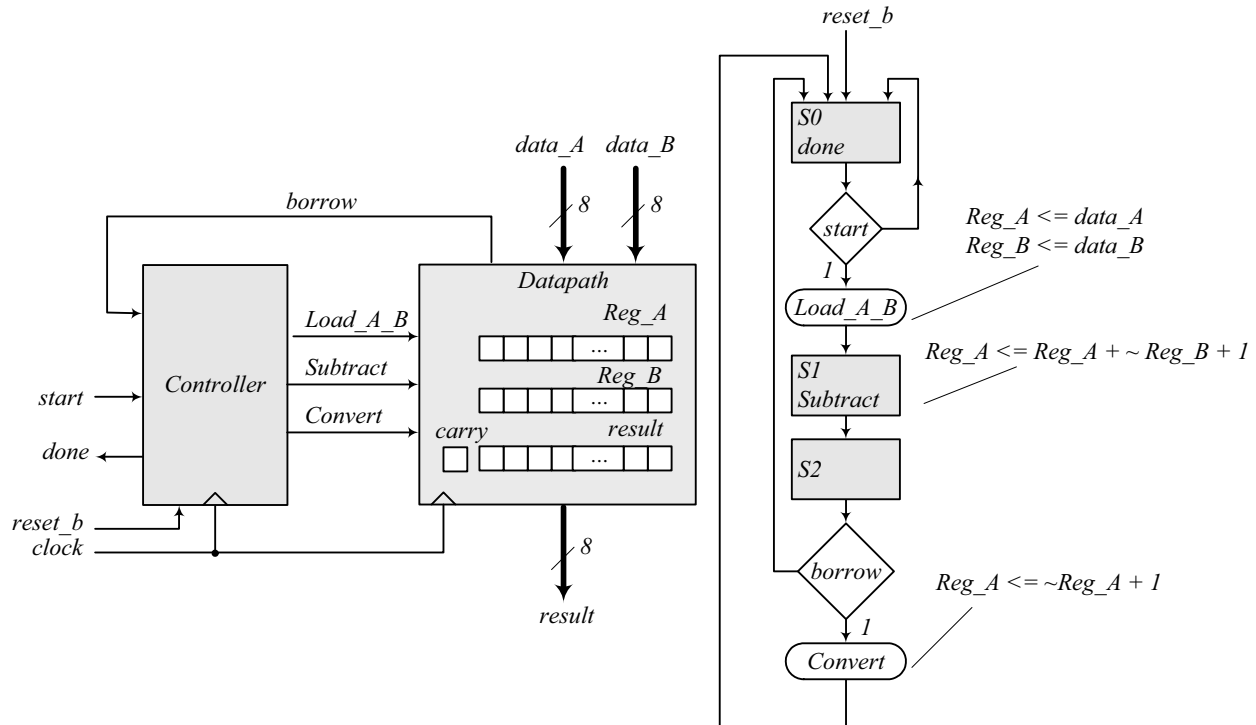

```

module Subtractor_P8_7
  (output done, output [7:0] result, input [7:0] data_A, data_B, input start, clock, reset_b);

  Controller_P8_7 M0 (Load_A_B, Subtract, Convert, done, start, borrow, clock, reset_b);
  Datapath_P8_7 M1 (result, borrow, data_A, data_B, Load_A_B, Subtract, Convert, clock, reset_b);
endmodule

module Controller_P8_7 (output reg Load_A_B, Subtract, output reg Convert, output done,
  input start, borrow, clock, reset_b);
  parameter S0 = 2'b00, S1 = 2'b01, S2 = 2'b10;
  reg [1:0] state, next_state;
  assign done = (state == S0);

  always @ (posedge clock, negedge reset_b)
    if (!reset_b) state <= S0; else state <= next_state;

  always @ (state, start, borrow) begin
    Load_A_B = 0;
    Subtract = 0;
    Convert = 0;

    case (state)
      S0: if (start) begin Load_A_B = 1; next_state = S1; end
      S1: begin Subtract = 1; next_state = S2; end
      S2: begin next_state = S0; if (borrow) Convert = 1; end
      default: next_state = S0;
    endcase
  end
endmodule

module Datapath_P8_7 (output [7:0] result, output borrow, input [7:0] data_A, data_B,
  input Load_A_B, Subtract, Convert, clock, reset_b);
  reg carry;
  reg [8:0] diff;
  reg [7:0] RA, RB;

```

```
assign borrow = carry;
assign result = RA;

always @(posedge clock, negedge reset_b)
if (!reset_b) begin carry <= 1'b0; RA <= 8'b0000_0000; RB <= 8'b0000_0000; end
else begin
if (Load_A_B) begin RA <= data_A; RB <= data_B; end
else if (Subtract) {carry, RA} <= RA + ~RB + 1;

// In the statement above, the math of the LHS is done to the wordlength of the LHS
// The statement below is more explicit about how the math for subtraction is done:
// else if (Subtract) {carry, RA} <= {1'b0, RA} + {1'b1, ~RB } + 9'b0000_0001;
// If the 9-th bit is not considered, the 2s complement operation will generate a carry bit,
// and borrow must be formed as borrow = ~carry.

else if (Convert) RA <= ~RA + 8'b0000_0001;
end
endmodule

// Test plan – Verify;
// Power-up reset
// Subtraction with data_A > data_B
// Subtraction with data_A < data_B
// Subtraction with data_A = data_B
// Reset on-the-fly: left as an exercise

module t_Subtractor_P8_7;
wire done;
wire [7:0] result;
reg [7:0] data_A, data_B;
reg start, clock, reset_b;

Subtractor_P8_7 M0 (done, result, data_A, data_B, start, clock, reset_b);

initial #200 $finish;
initial begin clock = 0; forever #5 clock = ~clock; end
initial fork
reset_b = 0;
#2 reset_b = 1;
#90 reset_b = 1;
#92 reset_b = 1;
join

initial fork
#20 start = 1;
#30 start = 0;
#70 start = 1;
#110 start = 1;
join

initial fork
data_A = 8'd50;
data_B = 8'd20;

#50 data_A = 8'd20;
#50 data_B = 8'd50;

#100 data_A = 8'd50;
#100 data_B = 8'd50;
join
endmodule
```

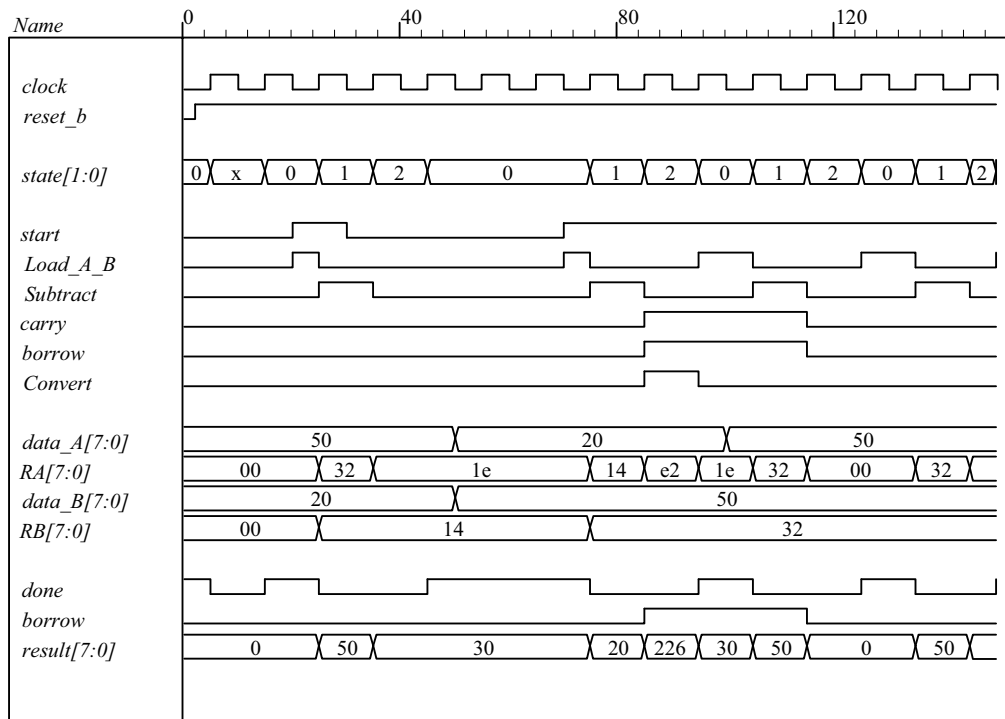

**8.8**

RTL notation:

*S0*: if (start = 1) *AR* ← input data, *BR* ← input data, go to *S1*.

*S1*: if (*AR* [15]) = 1 (sign bit negative) then *CR* ← *AR*(shifted right, sign extension).  
 else if (positive non-zero) then (Overflow ← *BR*[[15] ⊕ [14]], *CR* ← *BR*(shifted left))  
 else if (*AR* = 0) then (*CR* ← 0).

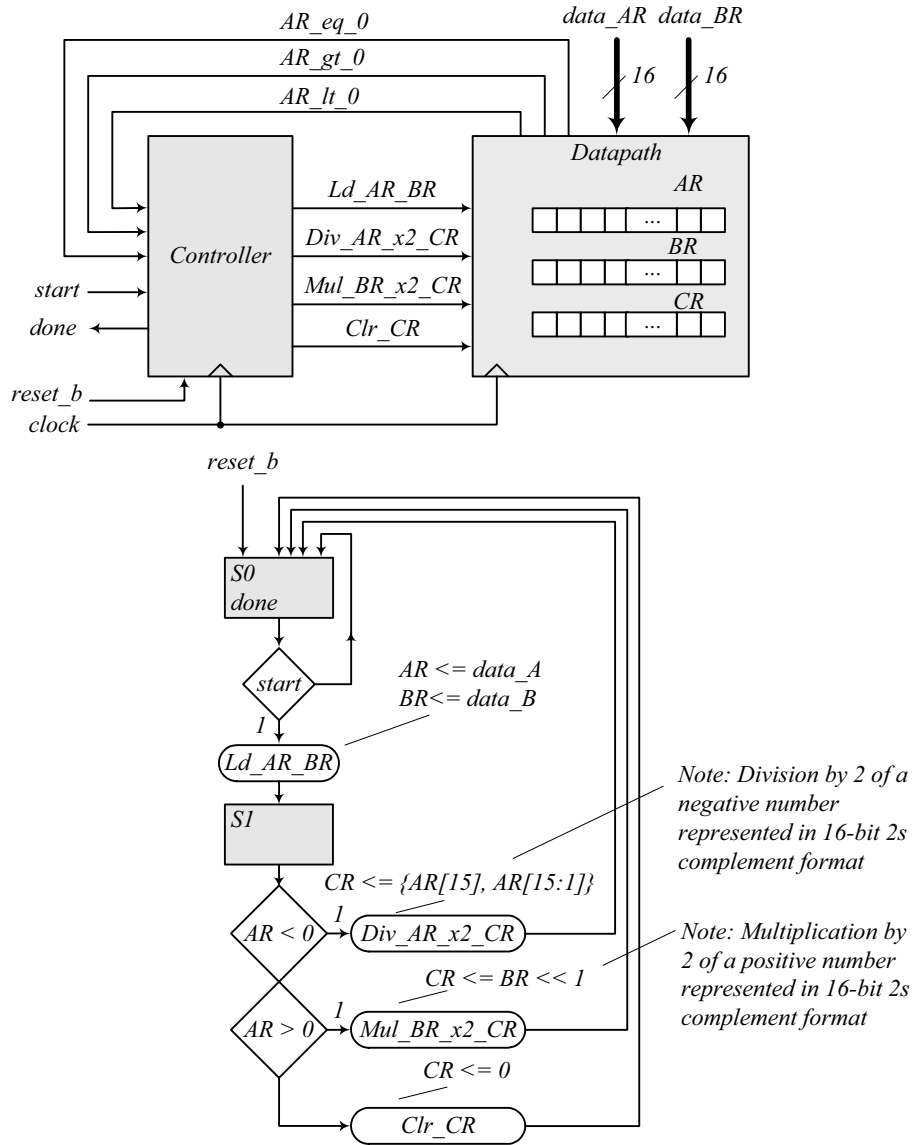

```
module Prob_8_8 (output done, input [15:0] data_AR, data_BR, input start, clock, reset_b);
```

```
Controller_P8_8 M0 (
    Ld_AR_BR, Div_AR_x2_CR, Mul_BR_x2_CR, Clr_CR, done,
    start, AR_lt_0, AR_gt_0, AR_eq_0, clock, reset_b
);
```

```
Datapath_P8_8 M1 (
    Overflow, AR_lt_0, AR_gt_0, AR_eq_0, data_AR, data_BR,
    Ld_AR_BR, Div_AR_x2_CR, Mul_BR_x2_CR, Clr_CR, clock, reset_b
);
endmodule
```

```

module Controller_P8_8 (
    output reg Ld_AR_BR, Div_AR_x2_CR, Mul_BR_x2_CR, Clr_CR,
    output done, input start, AR_lt_0, AR_gt_0, AR_eq_0, clock, reset_b
);
parameter S0 = 1'b0, S1 = 1'b1;
reg state, next_state;
assign done = (state == S0);

always @ (posedge clock, negedge reset_b)
    if (!reset_b) state <= S0; else state <= next_state;

always @ (state, start, AR_lt_0, AR_gt_0, AR_eq_0) begin
    Ld_AR_BR = 0;
    Div_AR_x2_CR = 0;
    Mul_BR_x2_CR = 0;
    Clr_CR = 0;

    case (state)
        S0: if (start) begin Ld_AR_BR = 1; next_state = S1; end
        S1: begin
            next_state = S0;
            if (AR_lt_0) Div_AR_x2_CR = 1;
            else if (AR_gt_0) Mul_BR_x2_CR = 1;
            else if (AR_eq_0) Clr_CR = 1;
        end
        default: next_state = S0;
    endcase
end
endmodule

module Datapath_P8_8 (
    output reg Overflow, output AR_lt_0, AR_gt_0, AR_eq_0, input [15: 0] data_AR, data_BR,
    input Ld_AR_BR, Div_AR_x2_CR, Mul_BR_x2_CR, Clr_CR, clock, reset_b
);
reg [15: 0] AR, BR, CR;
assign AR_lt_0 = AR[15];
assign AR_gt_0 = (!AR[15]) && (! AR[14:0]); // Reduction-OR
assign AR_eq_0 = (AR == 16'b0);

always @ (posedge clock, negedge reset_b)
    if (!reset_b) begin AR <= 8'b0; BR <= 8'b0; CR <= 16'b0; end
    else begin
        if (Ld_AR_BR) begin AR <= data_AR; BR <= data_BR; end
        else if (Div_AR_x2_CR) CR <= {AR[15], AR[15:1]}; // For compiler without arithmetic right shift
        else if (Mul_BR_x2_CR) {Overflow, CR} <= (BR << 1);
        else if (Clr_CR) CR <= 16'b0;
    end
endmodule

// Test plan – Verify;
// Power-up reset
// If AR < 0 divide AR by 2 and transfer to CR
// If AR > 0 multiply AR by 2 and transfer to CR
// If AR = 0 clear CR
// Reset on-the-fly

```

```
module t_Prob_P8_8;
  wire    done;
  reg [15: 0] data_AR, data_BR;
  reg      start, clock, reset_b;
  reg [15: 0] AR_mag, BR_mag, CR_mag; // To illustrate 2s complement math

// Probes for displaying magnitude of numbers
  always @ (M0.M1.AR) // Hierarchical dereferencing
    if (M0.M1.AR[15]) AR_mag = ~M0.M1.AR + 16'd1; else AR_mag = M0.M1.AR;
  always @ (M0.M1.BR )
    if (M0.M1.BR[15]) BR_mag = ~M0.M1.BR + 16'd1; else BR_mag = M0.M1.BR;
  always @ (M0.M1.CR)
    if (M0.M1.CR[15]) CR_mag = ~M0.M1.CR + 16'd1; else CR_mag = M0.M1.CR;

  Prob_8_8 M0 (done, data_AR, data_BR, start, clock, reset_b);

  initial #250 $finish;
  initial begin clock = 0; forever #5 clock = ~clock; end
  initial fork
    reset_b = 0; // Power-up reset
    #2 reset_b = 1;
    #50 reset_b = 0; // Reset on-the-fly
    #52 reset_b = 1;
    #90 reset_b = 1;
    #92 reset_b = 1;
  join

  initial fork
    #20 start = 1;
    #30 start = 0;
    #70 start = 1;
    #110 start = 1;
  join

  initial fork
    data_AR = 16'd50; // AR > 0
    data_BR = 16'd20; // Result should be 40

    #50 data_AR = 16'd20;
    #50 data_BR = 16'd50; // Result should be 100

    #100 data_AR = 16'd50;
    #100 data_BR = 16'd50;

    #130 data_AR = 16'd0; // AR = 0, result should clear CR

    #160 data_AR = -16'd20; // AR < 0, Verilog stores 16-bit 2s complement
    #160 data_BR = 16'd50; // Result should have magnitude 10

    #190 data_AR = 16'd20; // AR < 0, Verilog stores 16-bit 2s complement
    #190 data_BR = 16'hffff; // Result should have overflow
  join
endmodule
```

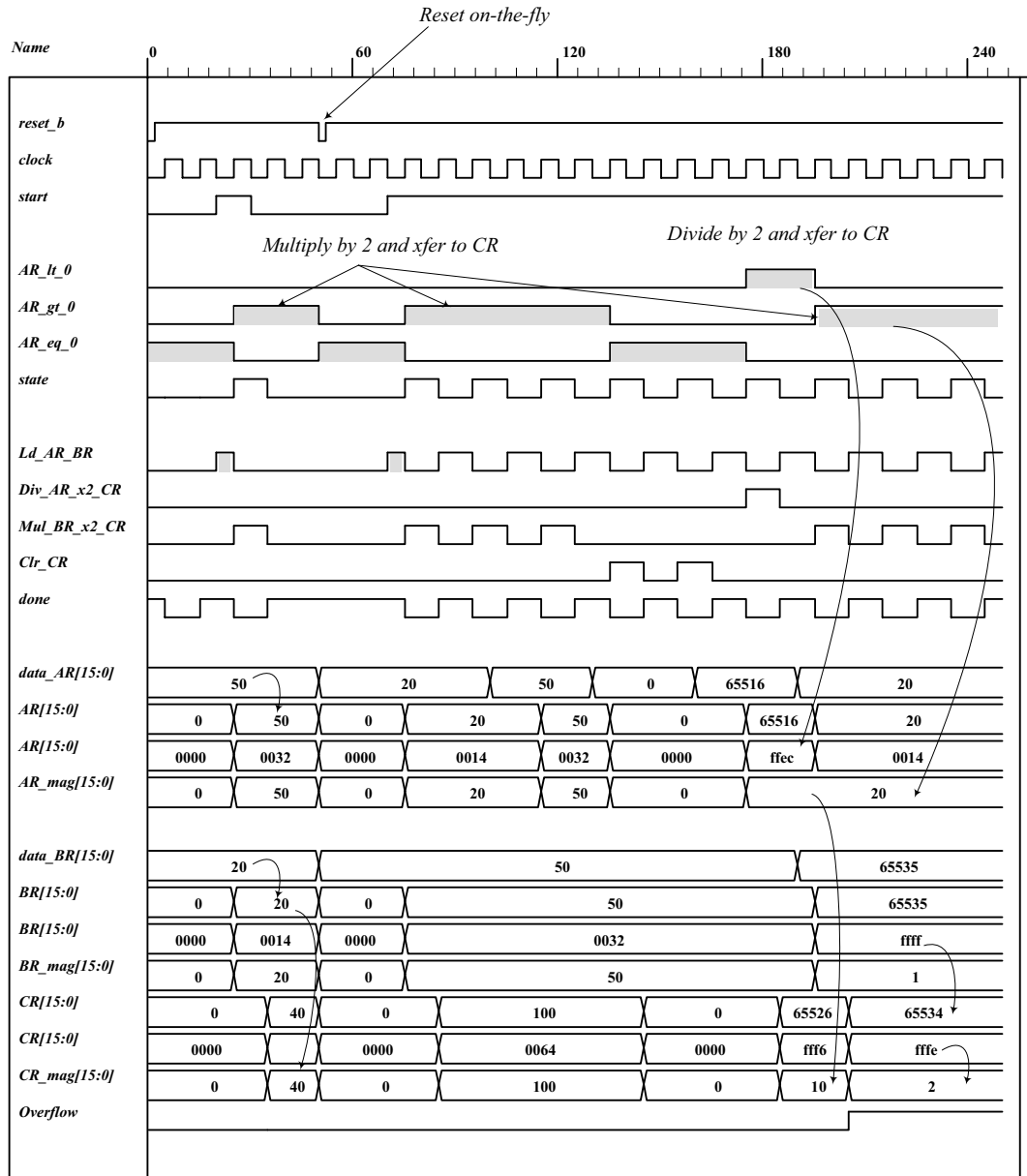

## 8.9

Design equations:

$$D_{S\_idle} = S\_2 + S\_idle \text{ Start}'$$

$$D_{S\_1} = S\_idle \text{ Start} + S\_1 (A2 \ A3)'$$

$$D_{S\_2} = A2 \ A3 \ S\_1$$

HDL description:

```
module Prob_8_9 (output E, F, output [3: 0] A, output A2, A3, input Start, clock, reset_b);
```

```
    Controller_Prob_8_9 M0 (set_E, clr_E, set_F, clr_A_F, incr_A, Start, A2, A3, clock, reset_b);
```

```
    Datapath_Prob_8_9 M1 (E, F, A, A2, A3, set_E, clr_E, set_F, clr_A_F, incr_A, clock, reset_b);
```

```
endmodule
```

```
// Structural version of the controller (one-hot)
```

```
// Note that the flip-flop for S_idle must have a set input and reset_b is wire to the set
```

```
// Simulation results match Fig. 8-13
```

```
module Controller_Prob_8_9 (
```

```
    output  set_E, clr_E, set_F, clr_A_F, incr_A,
```

```
    input   Start, A2, A3, clock, reset_b
```

```
);
```

```
    wire    D_S_idle, D_S_1, D_S_2;
```

```
    wire    q_S_idle, q_S_1, q_S_2;
```

```
    wire    w0, w1, w2, w3;
```

```
    wire [2:0] state = {q_S_2, q_S_1, q_S_idle};
```

```
// Next-State Logic
```

```
or (D_S_idle, q_S_2, w0);    // input to D-type flip-flop for q_S_idle
```

```
and (w0, q_S_idle, Start_b);
```

```
not (Start_b, Start);
```

```
or (D_S_1, w1, w2, w3);    // input to D-type flip-flop for q_S_1
```

```
and (w1, q_S_idle, Start);
```

```
and (w2, q_S_1, A2_b);
```

```
not (A2_b, A2);
```

```
and (w3, q_S_1, A2, A3_b);
```

```
not (A3_b, A3);
```

```
and (D_S_2, A2, A3, q_S_1);    // input to D-type flip-flop for q_S_2
```

```
D_flop_S M0 (q_S_idle, D_S_idle, clock, reset_b);
```

```
D_flop M1 (q_S_1, D_S_1, clock, reset_b);
```

```
D_flop M2 (q_S_2, D_S_2, clock, reset_b);
```

```
// Output Logic
```

```
and (set_E, q_S_1, A2);
```

```
and (clr_E, q_S_1, A2_b);
```

```
buf (set_F, q_S_2);
```

```
and (clr_A_F, q_S_idle, Start);
```

```
buf (incr_A, q_S_1);
```

```
endmodule
```

```
module D_flop (output reg q, input data, clock, reset_b);
```

```
    always @ (posedge clock, negedge reset_b)
```

```
        if (!reset_b) q <= 1'b0; else q <= data;
```

```
endmodule
```



```
module D_flop_S (output reg q, input data, clock, set_b);
    always @ (posedge clock, negedge set_b)
        if (!set_b) q <= 1'b1; else q <= data;
endmodule

/*
// RTL Version of the controller
// Simulation results match Fig. 8-13

module Controller_Prob_8_9 (
    output reg set_E, clr_E, set_F, clr_A_F, incr_A,
    input Start, A2, A3, clock, reset_b
);
    parameter S_idle = 3'b001, S_1 = 3'b010, S_2 = 3'b100; // One-hot
    reg [2: 0] state, next_state;

    always @ (posedge clock, negedge reset_b)
        if (!reset_b) state <= S_idle; else state <= next_state;

    always @ (state, Start, A2, A3) begin
        set_E = 1'b0;
        clr_E = 1'b0;
        set_F = 1'b0;
        clr_A_F = 1'b0;
        incr_A = 1'b0;
        case (state)
            S_idle: if (Start) begin next_state = S_1; clr_A_F = 1; end
                    else next_state = S_idle;

            S_1: begin
                    incr_A = 1;
                    if (!A2) begin next_state = S_1; clr_E = 1; end
                    else begin
                            set_E = 1;
                            if (A3) next_state = S_2; else next_state = S_1;
                        end
                    end

            S_2: begin next_state = S_idle; set_F = 1; end
            default: next_state = S_idle;
        endcase
    end
endmodule
*/

module Datapath_Prob_8_9 (
    output reg E, F, output reg [3: 0] A, output A2, A3,
    input set_E, clr_E, set_F, clr_A_F, incr_A, clock, reset_b
);
    assign A2 = A[2];
    assign A3 = A[3];

    always @ (posedge clock, negedge reset_b) begin
        if (!reset_b) begin E <= 0; F <= 0; A <= 0; end
        else begin
            if (set_E) E <= 1;
            if (clr_E) E <= 0;
            if (set_F) F <= 1;
            if (clr_A_F) begin A <= 0; F <= 0; end
            if (incr_A) A <= A + 1;
        end
    end
endmodule
```

// Test Plan - Verify: (1) Power-up reset, (2) match ASMD chart in Fig. 8-9 (d),  
 // (3) recover from reset on-the-fly

```

module t_Prob_8_9;
wire E, F;
wire [3: 0] A;
wire A2, A3;
reg Start, clock, reset_b;

    Prob_8_9 M0 (E, F, A, A2, A3, Start, clock, reset_b);

initial #500 $finish;
initial begin clock = 0; forever #5 clock = ~clock; end
initial begin reset_b = 0; #2 reset_b = 1; end
initial fork
    #20 Start = 1;
    #40 reset_b = 0;
    #62 reset_b = 1;
join
endmodule
    
```

8.10

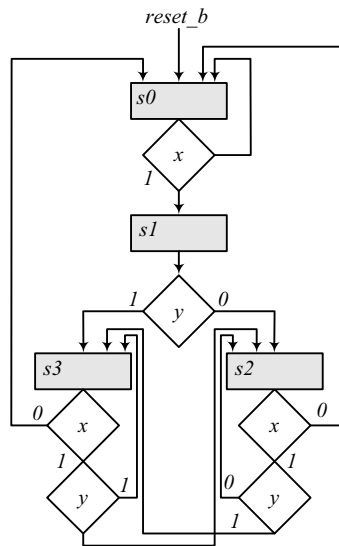

```

module Prob_8_10 (input x, y, clock, reset_b);
reg [ 1: 0] state, next_state;
parameter s0 = 2'b00, s1 = 2'b01, s2 = 2'b10, s3 = 2'b11;
always @ (posedge clock, negedge reset_b)
    if (reset_b == 0) state <= s0; else state <= next_state;

always @ (state, x, y) begin
    next_state = s0;
    case (state)
        s0: if (x == 0) next_state = s0; else next_state = s1;
        s1: if (y == 0) next_state = s2; else next_state = s3;
        s2: if (x == 0) next_state = s0; else if (y == 0) next_state = s2; else next_state = s3;
        s3: if (x == 0) next_state = s0; else if (y == 0) next_state = s2; else next_state = s3;
    endcase
end
endmodule
    
```

```

module t_Prob_8_10 ();
  reg x, y, clock, reset_b;

  Prob_8_10 M0 (x, y, clock, reset_b);

  initial #150 $finish;
  initial begin clock = 0; forever #5 clock = ~clock; end
  initial fork
    reset_b = 0;
    #12 reset_b = 1;
    x = 0; y = 0;      // Remain in s0
    #10 y = 1;        // Remain in s0
    #20 x = 1;        // Go to s1 to s3
    #40 reset_b = 0;  // Go to s0
    #42 reset_b = 1;  // Go to s2 to s3
    #60 y = 0;        // Go to s2
    #80 y = 1;        // Go to s3
    #90 x = 0;        // Go to s0
    #100 x = 1;       // Go to s1
    #110 y = 0;       // Go to s2
    #130 x = 0;       // Go to s0
  join
endmodule

```

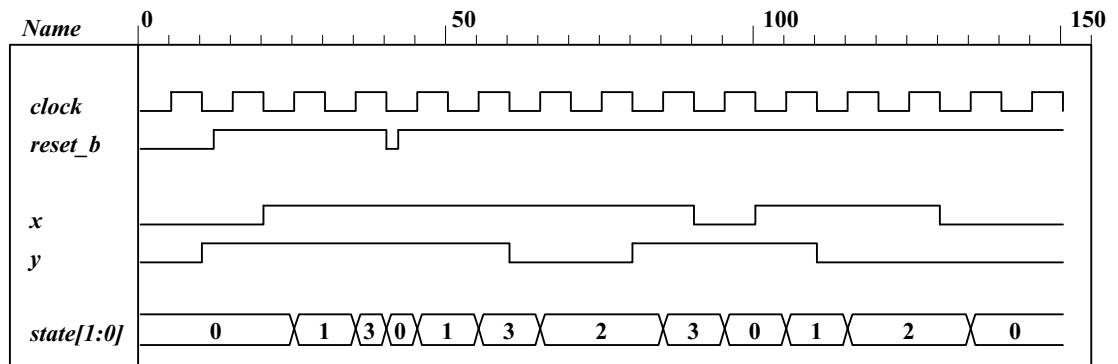

**8.11**  $D_A = A'B + Ax$   
 $D_B = A'B'x + A'By + xy$

state	inputs	next state
0 0	0 0	0 0
0 0	0 1	0 0
0 0	1 0	0 1
0 0	1 1	0 1
0 1	0 0	1 0
0 1	0 1	1 1
0 1	1 0	1 0
0 1	1 1	1 1
1 0	0 0	0 0
1 0	0 1	0 0
1 0	1 0	1 0
1 0	1 1	1 1
1 1	0 0	0 0
1 1	0 1	0 0
1 1	1 0	1 0
1 1	1 1	1 1

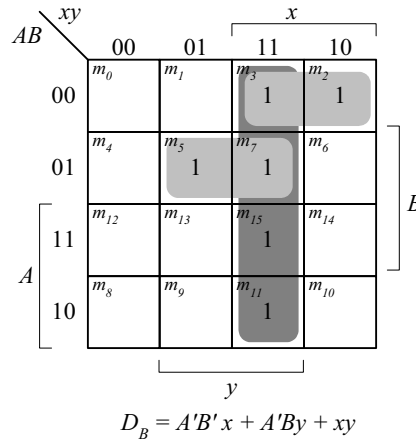
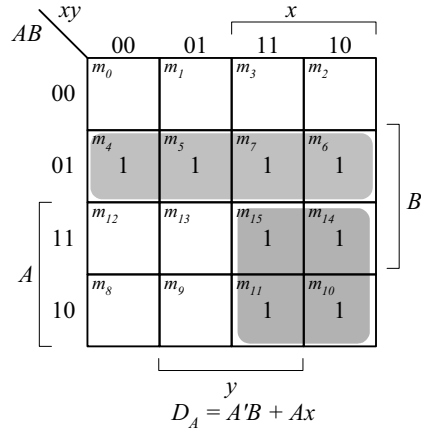

**8.12** Modify the counter in Fig. 6.12 to add a signal, Clear, to clear the counter synchronously, as shown in the circuit diagram below.

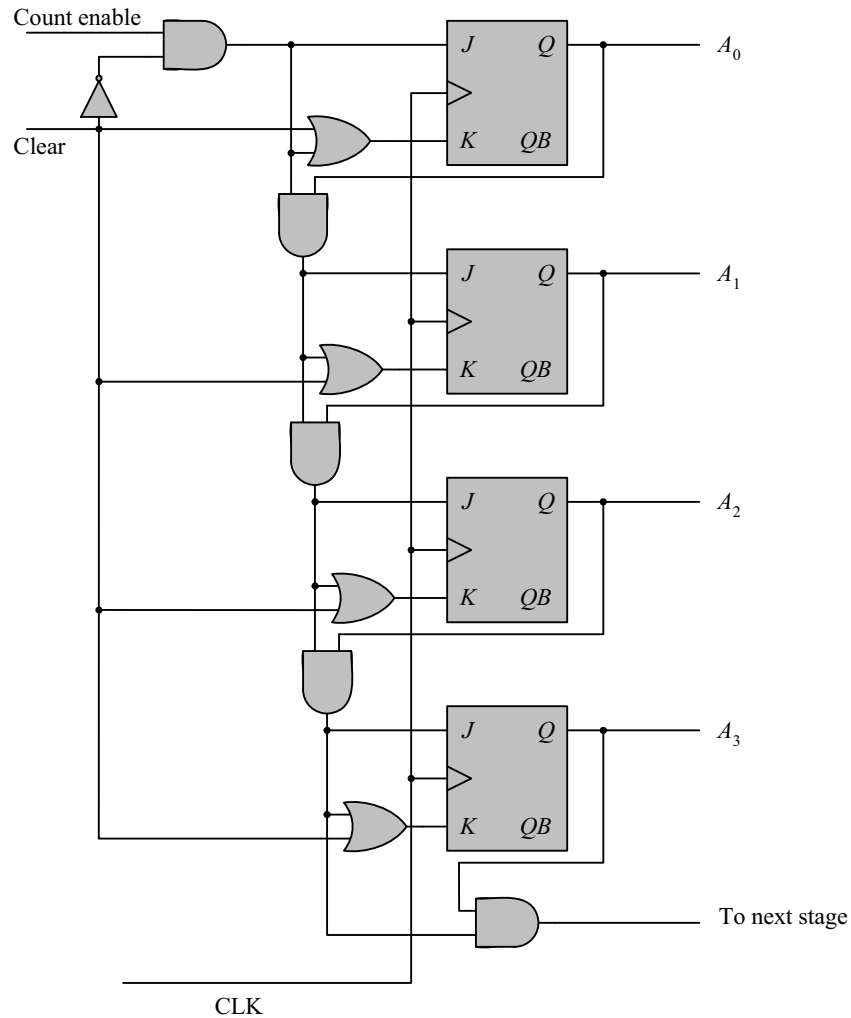

```

module Counter_4bit_Synch_Clr (output [3: 0] A, output next_stage, input Count_enable, Clear, CLK);
  wire A0, A1, A2, A3;
  assign A[3: 0] = {A3, A2, A1, A0};
  JK_FF M0 (A0, J0, K0, CLK);
  JK_FF M1 (A1, J1, K1, CLK);
  JK_FF M2 (A2, J2, K2, CLK);
  JK_FF M3 (A3, J3, K3, CLK);

  not (Clear_b, Clear);
  and (J0, Count_enable, Clear_b);
  and (J1, J0, A0);
  and (J2, J1, A1);
  and (J3, J2, A2);

  or (K0, Clear, J0);
  or (K1, Clear, J1);
  or (K2, Clear, J2);
  or (K3, Clear, J3);

  and (next_stage, A3, J3);
endmodule

```

```

module JK_FF (output reg Q, input J, K, clock);
  always @ (posedge clock)
    case ({J,K})
      2'b00: Q <= Q;
      2'b01: Q <= 0;
      2'b10: Q <= 1;
      2'b11: Q <= ~Q;
    endcase
endmodule

```

```

module t_Counter_4bit_Synch_Clr ();
  wire [3: 0] A;
  wire next_stage;
  reg Count_enable, Clear, clock;

```

Counter\_4bit\_Synch\_Clr M0 (A, next\_stage, Count\_enable, Clear, clock);

```

initial #300 $finish;
initial begin clock = 0; forever #5 clock = ~clock; end
initial fork
  Clear = 1;
  Count_enable = 0;
  #12 Clear = 0;
  #20 Count_enable = 1;
  #180 Clear = 1;
  #190 Clear = 0;
  #230 Count_enable = 0;
join
endmodule

```

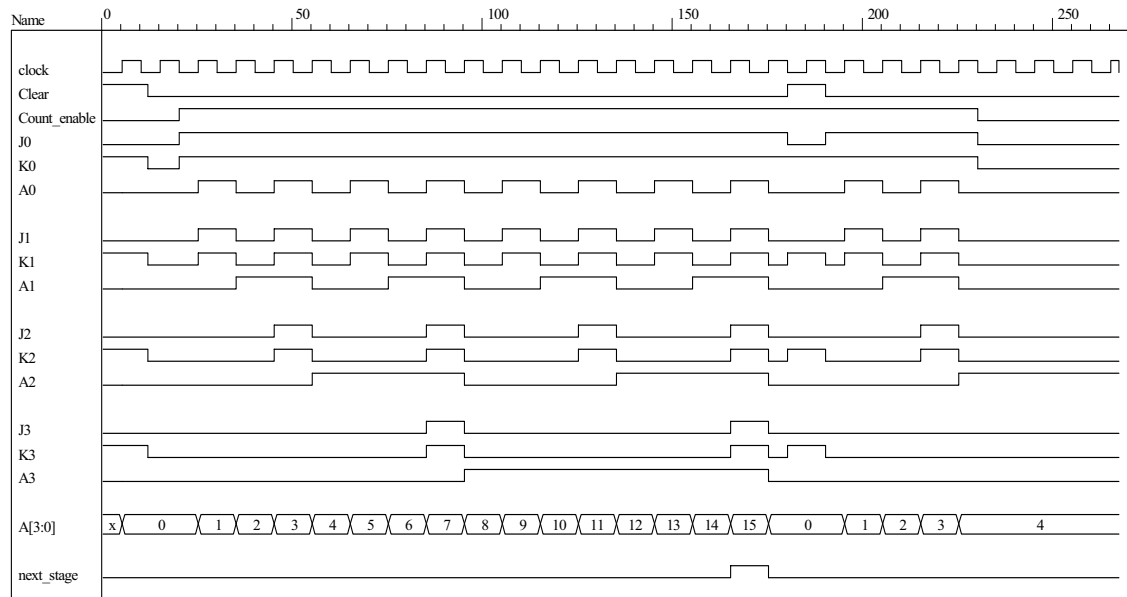

8.13

// Structural description of design example (Fig. 8-10, 8-12)

```

module Design_Example_STR

  (output [3:0] A,
   output E, F,
   input Start, clock, reset_b
  );

```

```
Controller_STR M0 (clr_A_F, set_E, clr_E, set_F, incr_A, Start, A[2], A[3], clock, reset_b);
Datapath_STR M1 (A, E, F, clr_A_F, set_E, clr_E, set_F, incr_A, clock);
endmodule
```

```
module Controller_STR
(output clr_A_F, set_E, clr_E, set_F, incr_A,
 input Start, A2, A3, clock, reset_b
);

wire G0, G1;
parameter S_idle = 2'b00, S_1 = 2'b01, S_2 = 2'b11;
wire w1, w2, w3;

not (G0_b, G0);
not (G1_b, G1);
buf (incr_A, w2);
buf (set_F, G1);
not (A2_b, A2);
or (D_G0, w1, w2);
and (w1, Start, G0_b);
and (clr_A_F, G0_b, Start);
and (w2, G0, G1_b);
and (set_E, w2, A2);
and (clr_E, w2, A2_b);
and (D_G1, w3, w2);
and (w3, A2, A3);
D_flip_flop_AR M0 (G0, D_G0, clock, reset_b);
D_flip_flop_AR M1 (G1, D_G1, clock, reset_b);
endmodule
```

```
// datapath unit
```

```
module Datapath_STR
(output [3: 0] A,
 output E, F,
 input clr_A_F, set_E, clr_E, set_F, incr_A, clock
);

JK_flip_flop_2 M0 (E, E_b, set_E, clr_E, clock);
JK_flip_flop_2 M1 (F, F_b, set_F, clr_A_F, clock);
Counter_4 M2 (A, incr_A, clr_A_F, clock);
```

```
endmodule
```

```
module Counter_4 (output reg [3: 0] A, input incr, clear, clock);
always @ (posedge clock)
if (clear) A <= 0; else if (incr) A <= A + 1;
endmodule
```

```
module D_flip_flop_AR (Q, D, CLK, RST);
output Q;
input D, CLK, RST;
reg Q;
```

```
always @ (posedge CLK, negedge RST)
if (RST == 0) Q <= 1'b0;
else Q <= D;
endmodule
```

```
module JK_flip_flop_2 (Q, Q_not, J, K, CLK);
```

```
output Q, Q_not;
input J, K, CLK;
reg Q;

assign Q_not = ~Q
;
always @ (posedge CLK)
case ({J, K})
2'b00: Q <= Q;
2'b01: Q <= 1'b0;
2'b10: Q <= 1'b1;
2'b11: Q <= ~Q;
endcase
endmodule

module t_Design_Example_STR;
reg Start, clock, reset_b;
wire [3:0] A;
wire E, F;
wire [1:0] state_STR = {M0.M0.G1, M0.M0.G0};

Design_Example_STR M0 (A, E, F, Start, clock, reset_b);

initial #500 $finish;
initial
begin
reset_b = 0;
Start = 0;
clock = 0;
#5 reset_b = 1; Start = 1;
repeat (32)
begin
#5 clock = ~ clock;
end
end
initial
$monitor ("A = %b E = %b F = %b time = %0d", A, E, F, $time);
endmodule
```

The simulation results shown below match Fig. 8.13.



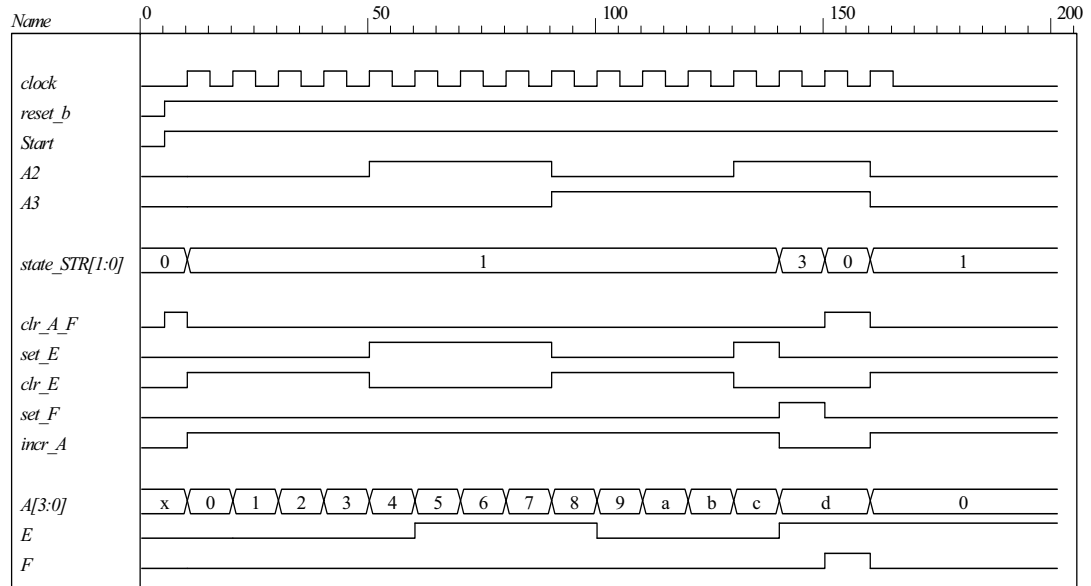

**8.14** The state code 2'b10 is unused. If the machine enters an unused state, the controller is written with default assignment to *next\_state*. The default assignment forces the state to *S\_idle*, so the machine recovers from the condition.

**8.15** Modify the test bench to insert a reset event and extend the clock.

// RTL description of design example (see Fig.8-11)

```
module Design_Example_RTL (A, E, F, Start, clock, reset_b);
```

```
// Specify ports of the top-level module of the design
// See block diagram Fig. 8-10
```

```
output [3: 0]  A;
output        E, F;
input        Start, clock, reset_b;
```

```
// Instantiate controller and datapath units
```

```
Controller_RTL M0 (set_E, clr_E, set_F, clr_A_F, incr_A, A[2], A[3], Start, clock, reset_b );
Datapath_RTL M1 (A, E, F, set_E, clr_E, set_F, clr_A_F, incr_A, clock);
```

```
endmodule
```

```
module Controller_RTL (set_E, clr_E, set_F, clr_A_F, incr_A, A2, A3, Start, clock, reset_b);
output reg  set_E, clr_E, set_F, clr_A_F, incr_A;
input      Start, A2, A3, clock, reset_b;
reg [1:0]  state, next_state;
parameter  S_idle = 2'b00, S_1 = 2'b01, S_2 = 2'b11; // State codes
```

```
always @ (posedge clock or negedge reset_b) // State transitions (edge-sensitive)
if (reset_b == 0) state <= S_idle;
else state <= next_state;
```

```
// Code next state logic directly from ASMD chart (Fig. 8-9d)
```

```
always @ (state, Start, A2, A3 ) begin // Next state logic (level-sensitive)
next_state = S_idle;
```

```
    case (state)
      S_idle:  if (Start) next_state = S_1; else next_state = S_idle;
      S_1:    if (A2 & A3) next_state = S_2; else next_state = S_1;
      S_2:    next_state = S_idle;
      default: next_state = S_idle;
    endcase
end

// Code output logic directly from ASMD chart (Fig. 8-9d)

always @ (state, Start, A2) begin
  set_E = 0;      // default assignments; assign by exception
  clr_E = 0;
  set_F = 0;
  clr_A_F = 0;
  incr_A = 0;
  case (state)
    S_idle:      if (Start) clr_A_F = 1;
    S_1:         begin incr_A = 1; if (A2) set_E = 1; else clr_E = 1; end
    S_2:         set_F = 1;
  endcase
end
endmodule

module Datapath_RTL (A, E, F, set_E, clr_E, set_F, clr_A_F, incr_A, clock);
  output reg [3: 0]  A;      // register for counter
  output reg        E, F;   // flags
  input             set_E, clr_E, set_F, clr_A_F, incr_A, clock;

  // Code register transfer operations directly from ASMD chart (Fig. 8-9d)

  always @ (posedge clock) begin
    if (set_E)      E <= 1;
    if (clr_E)      E <= 0;
    if (set_F)      F <= 1;
    if (clr_A_F)    begin A <= 0; F <= 0; end
    if (incr_A)     A <= A + 1;
  end
endmodule

module t_Design_Example_RTL;
  reg        Start, clock, reset_b;
  wire [3: 0] A;
  wire      E, F;

  // Instantiate design example

  Design_Example_RTL M0 (A, E, F, Start, clock, reset_b);

  // Describe stimulus waveforms

  initial #500 $finish;    // Stopwatch
  initial fork
    #25 reset_b = 0;      // Test for recovery from reset on-the-fly.
    #27 reset_b = 1;
  join
  initial
  begin
    reset_b = 0;
    Start = 0;
    clock = 0;
  end
endmodule
```

```

#5 reset_b = 1; Start = 1;
//repeat (32)
repeat (38)          // Modify for test of reset_b on-the-fly
begin
#5 clock = ~ clock; // Clock generator
end
end
initial
$monitor ("A = %b E = %b F = %b time = %0d", A, E, F, $time);
endmodule

```

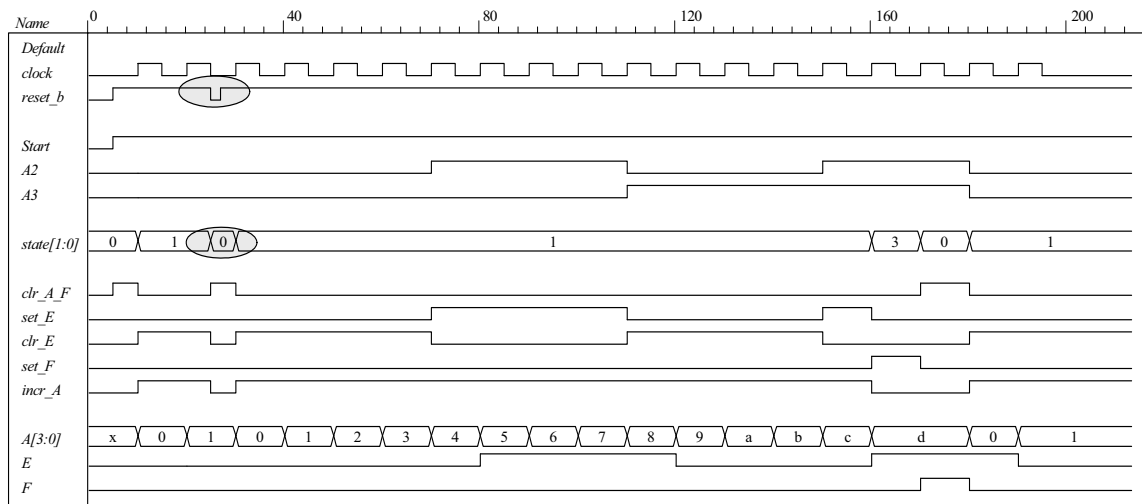

**8.16**

RTL notation:

*s0*: (initial state) If *start* = 0 go back to state *s0*, If (*start* = 1) then  $BR \leftarrow multiplicand$ ,  $AR \leftarrow multiplier$ ,  $PR \leftarrow 0$ , go to *s1*.

*s1*: (check *AR* for Zero) *Zero* = 1 if  $AR = 0$ , if (*Zero* = 1) then go back to *s0* (*done*) If (*Zero* = 0) then go to *s1*,  $PR \leftarrow PR + BR$ ,  $AR \leftarrow AR - 1$ .

The internal architecture of the datapath consists of a double-width register to hold the product (*PR*), a register to hold the multiplier (*AR*), a register to hold the multiplicand (*BR*), a double-width parallel adder, and single-width parallel adder. The single-width adder is used to implement the operation of decrementing the multiplier unit. Adding a word consisting entirely of 1s to the multiplier accomplishes the 2's complement subtraction of 1 from the multiplier. Figure 8.16 (a) below shows the ASMD chart, block diagram, and controller of the circuit. Figure 8.16 (b) shows the internal architecture of the datapath. Figure 8.16 (c) shows the results of simulating the circuit.

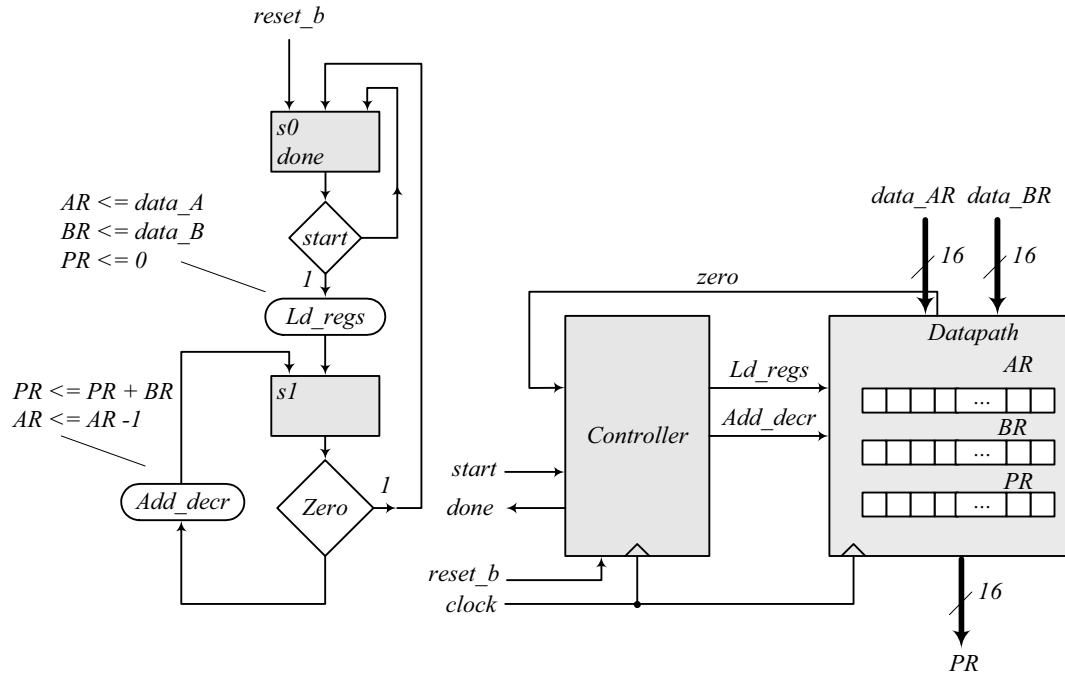

Note: Form Zero as the output of an OR gate whose inputs are the bits of the register AR.

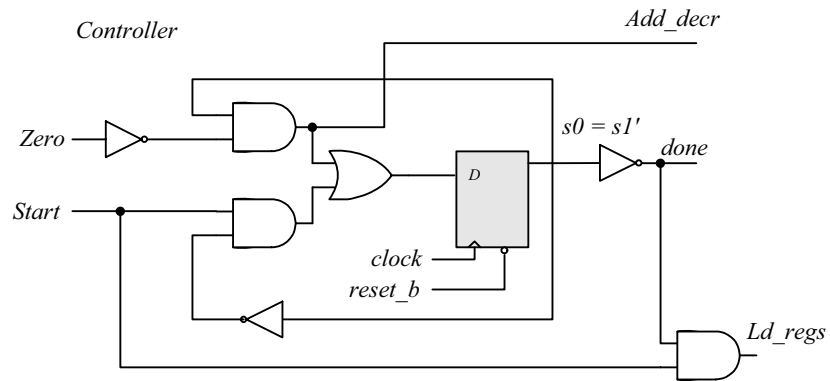

(a) ASMD chart, block diagram, and controller

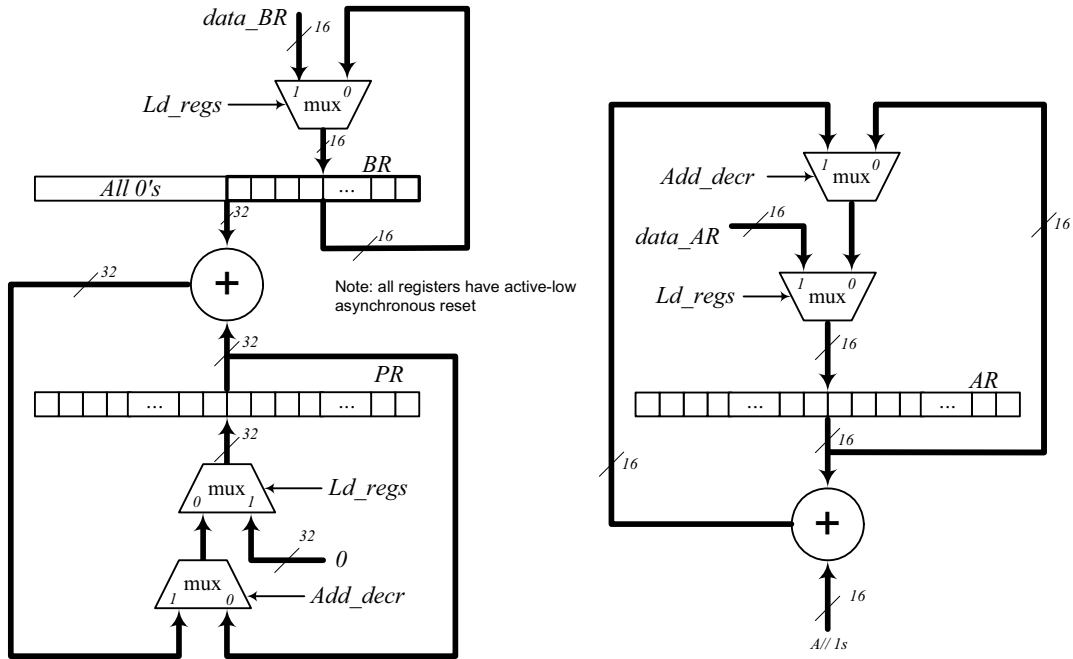

(b) Datapath

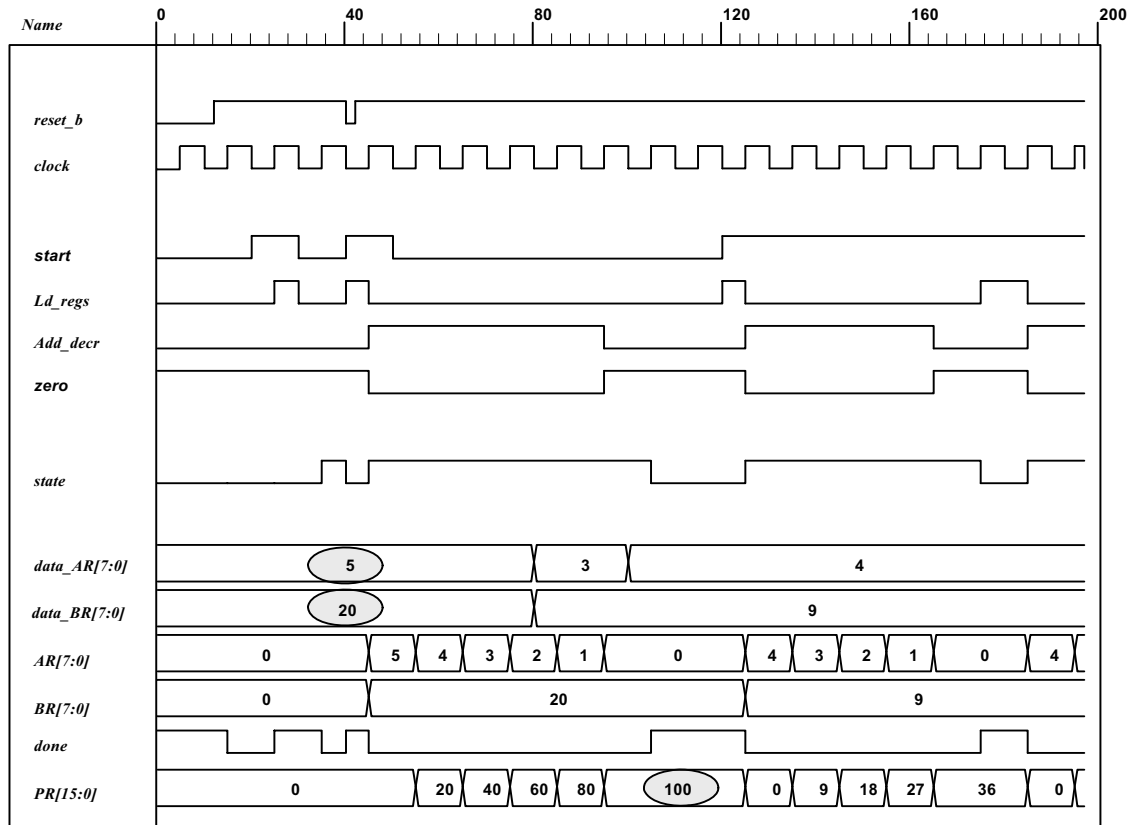

(c) Simulation results

```
module Prob_8_16_STR (  
output [15: 0] PR, output done,  
input [7: 0] data_AR, data_BR, input start, clock, reset_b  
);
```

```
Controller_P8_16 M0 (done, Ld_regs, Add_decr, start, zero, clock, reset_b);
```

```
Datapath_P8_16 M1 (PR, zero, data_AR, data_BR, Ld_regs, Add_decr, clock, reset_b);  
endmodule
```

```
module Controller_P8_16 (output done, output reg Ld_regs, Add_decr, input start, zero, clock, reset_b);  
parameter s0 = 1'b0, s1 = 1'b1;  
reg state, next_state;  
assign done = (state == s0);
```

```
always @ (posedge clock, negedge reset_b)  
if (!reset_b) state <= s0; else state <= next_state;
```

```
always @ (state, start, zero) begin  
Ld_regs = 0;  
Add_decr = 0;  
case (state)  
s0: if (start) begin Ld_regs = 1; next_state = s1; end  
s1: if (zero) next_state = s0; else begin next_state = s1; Add_decr = 1; end  
default: next_state = s0;  
endcase  
end  
endmodule
```

```
module Register_32 (output [31: 0] data_out, input [31: 0] data_in, input clock, reset_b);  
Register_8 M3 (data_out [31: 24] , data_in [31: 24], clock, reset_b);  
Register_8 M2 (data_out [23: 16] , data_in [23: 16], clock, reset_b);  
Register_8 M1 (data_out [15: 8] , data_in [15: 8], clock, reset_b);  
Register_8 M0 (data_out [7: 0] , data_in [7: 0], clock, reset_b);  
endmodule
```

```
module Register_16 (output [15: 0] data_out, input [15: 0] data_in, input clock, reset_b);  
Register_8 M1 (data_out [15: 8] , data_in [15: 8], clock, reset_b);  
Register_8 M0 (data_out [7: 0] , data_in [7: 0], clock, reset_b);  
endmodule
```

```
module Register_8 (output [7: 0] data_out, input [7: 0] data_in, input clock, reset_b);  
D_flop M7 (data_out[7] data_in[7], clock, reset_b);  
D_flop M6 (data_out[6] data_in[6], clock, reset_b);  
D_flop M5 (data_out[5] data_in[5], clock, reset_b);  
D_flop M4 (data_out[4] data_in[4], clock, reset_b);  
D_flop M3 (data_out[3] data_in[3], clock, reset_b);  
D_flop M2 (data_out[2] data_in[2], clock, reset_b);  
D_flop M1 (data_out[1] data_in[1], clock, reset_b);  
D_flop M0 (data_out[0] data_in[0], clock, reset_b);  
endmodule
```

```
module Adder_32 (output c_out, output [31: 0] sum, input [31: 0] a, b);  
assign {c_out, sum} = a + b;  
endmodule
```

```
module Adder_16 (output c_out, output [15: 0] sum, input [15: 0] a, b);  
assign {c_out, sum} = a + b;  
endmodule
```

```
module D_flop (output q, input data, clock, reset_b);
always @ (posedge clock, negedge reset_b)
if (!reset_b) q <= 0; else q <= data;
endmodule

module Datapath_P8_16 (
output reg [15: 0] PR, output zero,
input [7: 0] data_AR, data_BR, input Ld_regs, Add_decr, clock, reset_b
);

reg [7: 0] AR, BR;
assign zero = ~( | AR);

always @ (posedge clock, negedge reset_b)
if (!reset_b) begin AR <= 8'b0; BR <= 8'b0; PR <= 16'b0; end
else begin
if (Ld_regs) begin AR <= data_AR; BR <= data_BR; PR <= 0; end
else if (Add_decr) begin PR <= PR + BR; AR <= AR -1; end
end
endmodule

// Test plan – Verify;
// Power-up reset
// Data is loaded correctly
// Control signals assert correctly
// Status signals assert correctly
// start is ignored while multiplying
// Multiplication is correct
// Recovery from reset on-the-fly

module t_Prob_P8_16;
wire done;
wire [15: 0] PR;
reg [7: 0] data_AR, data_BR;
reg start, clock, reset_b;

Prob_8_16_STR M0 (PR, done, data_AR, data_BR, start, clock, reset_b);

initial #500 $finish;
initial begin clock = 0; forever #5 clock = ~clock; end
initial fork
reset_b = 0;
#12 reset_b = 1;
#40 reset_b = 0;
#42 reset_b = 1;
#90 reset_b = 1;
#92 reset_b = 1;
join

initial fork
#20 start = 1;
#30 start = 0;
#40 start = 1;
#50 start = 0;
#120 start = 1;
#120 start = 0;
join
```

```

initial fork
data_AR = 8'd5;    // AR > 0
data_BR = 8'd20;

#80 data_AR = 8'd3;
#80 data_BR = 8'd9;

#100 data_AR = 8'd4;
#100 data_BR = 8'd9;
join
endmodule

```

**8.17**  $(2^n - 1)(2^n - 1) < (2^{2n} - 1)$  for  $n \geq 1$

- 8.18** (a) The maximum product size is 32 bits available in registers  $A$  and  $Q$ .  
 (b)  $P$  counter must have 5 bits to load 16 (binary 10000) initially.  
 (c)  $Z$  (zero) detection is generated with a 5-input NOR gate.

**8.19**

**Multiplicand**  $B = 11011_2 = 27_{10}$   
**Multiplier**  $Q = 10111_2 = 23_{10}$   
**Product:**  $CAQ = 621_{10}$

	$C$	$A$	$Q$	$P$
Multiplier in $Q$	0	00000	10111	101
$Q0 = 1$ ; add $B$		11011		
First partial product	0	11011	10111	100
Shift right $CAQ$	0	01101	11011	
$Q0 = 1$ ; add $B$		11011		
Second partial product	1	01000	11011	011
Shift right $CAQ$	0	10100	01101	
$Q0 = 1$ ; add $B$		11011		
Third partial product	1	01111	01101	010
Shift right $CAQ$	0	10111	10110	
Shift right $CAQ$	0	01011	11011	
Fourth partial product	0	01011	11011	001
$Q0 = 1$ ; add $B$		11011		
Fifth partial product	1	00110	11011	000
Shift right $CAQ$	0	10011	01101	
Final product in $AQ$ : $AQ = 10011\ 01101 = 621_{10}$				

- 8.20**  $S_{idle} = 1t$  ns  
 The loop between  $S_{add}$  and  $S_{shift}$  takes  $2nt$  ns  
 Total time to multiply:  $(2n + 1)t$

**8.21**



State codes:	$G_1$	$G_0$
$S\_idle$	0	0
$S\_add$	0	1
$S\_shift1$	0	0
unused	0	0

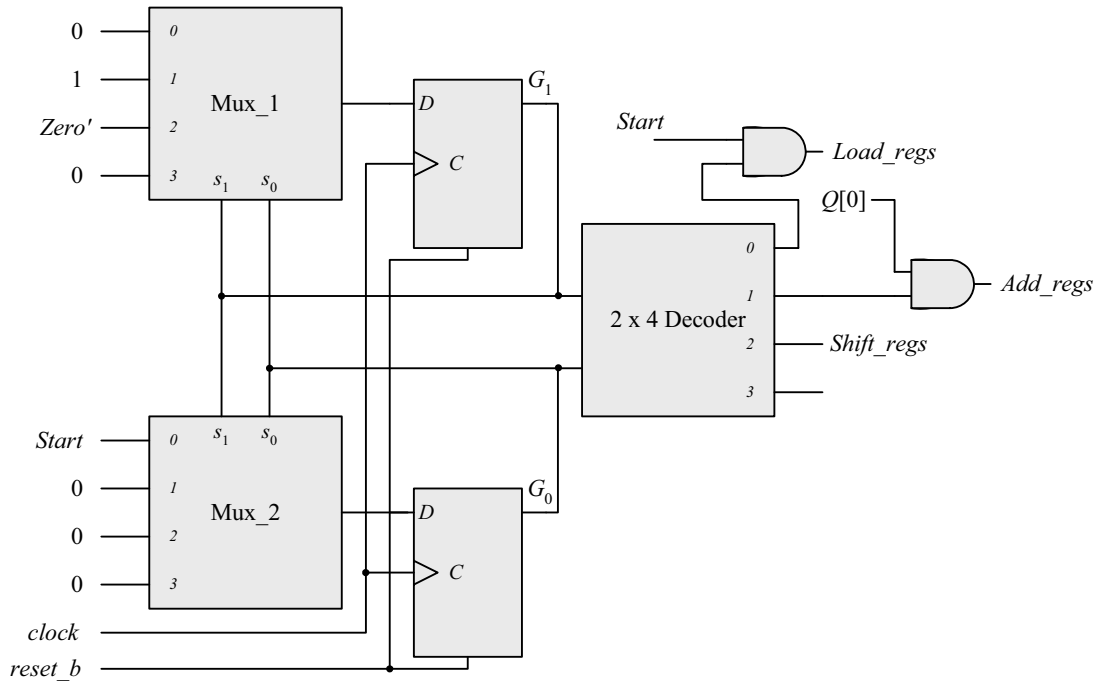

**8.22** Note that the machine described by Fig. P8.22 requires four states, but the machine described by Fig. 8.15 (b) requires only three. Also, observe that the sample simulation results show a case where the carry bit register, C, is needed to support the addition operation. The datapath is 8 bits wide.

```

module Prob_8_22 # (parameter m_size = 9)
(
  output [2*m_size -1: 0] Product,
  output Ready,
  input [m_size -1: 0] Multiplicand, Multiplier,
  input Start, clock, reset_b
);
  wire [m_size -1: 0] A, Q;

  assign Product = {A, Q};
  wire Q0, Zero, Load_regs, Decr_P, Add_regs, Shift_regs;

```

```

Datapath_Unit M0 (A, Q, Q0, Zero, Multiplicand, Multiplier, Load_regs, Decr_P, Add_regs, Shift_regs,
clock, reset_b);
Control_Unit M1 (Ready, Decr_P, Load_regs, Add_regs, Shift_regs, Start, Q0, Zero, clock, reset_b);
endmodule

```

```
module Datapath_Unit # (parameter m_size = 9, BC_size = 4)
(
  output reg [m_size -1: 0] A, Q,
  output Q0, Zero,
  input [m_size -1: 0] Multiplicand, Multiplier,
  input Load_regs, Decr_P, Add_regs, Shift_regs, clock, reset_b
);
  reg C;
  reg [BC_size -1: 0] P;
  reg [m_size -1: 0] B;

  assign Q0 = Q[0];
  assign Zero = (P == 0);

  always @ (posedge clock, negedge reset_b)
    if (reset_b == 0) begin
      B <= 0; C <= 0;
      A <= 0;
      Q <= 0;
      P <= m_size;
    end
  else begin
    if (Load_regs) begin
      A <= 0;
      C <= 0;
      Q <= Multiplier;
      B <= Multiplicand;
      P <= m_size;
    end
    if (Decr_P) P <= P -1;
    if (Add_regs) {C, A} <= A + B;
    if (Shift_regs) {C, A, Q} <= {C, A, Q} >> 1;
  end
endmodule

module Control_Unit (
  output Ready, Decr_P, output reg Load_regs, Add_regs, Shift_regs, input Start, Q0, Zero, clock,
  reset_b
);
  reg [ 1: 0] state, next_state;
  parameter S_idle = 2'b00, S_loaded = 2'b01, S_sum = 2'b10, S_shifted = 2'b11;
  assign Ready = (state == S_idle);
  assign Decr_P = (state == S_loaded);

  always @ (posedge clock, negedge reset_b)
    if (reset_b == 0) state <= S_idle; else state <= next_state;

  always @ (state, Start, Q0, Zero) begin
    next_state = S_idle;
    Load_regs = 0;
    Add_regs = 0;
    Shift_regs = 0;
    case (state)
      S_idle: if (Start == 0) next_state = S_idle; else begin next_state = S_loaded; Load_regs = 1; end
      S_loaded: if (Q0) begin next_state = S_sum; Add_regs = 1; end
      else begin next_state = S_shifted; Shift_regs = 1; end
      S_sum: begin next_state = S_shifted; Shift_regs = 1; end
      S_shifted: if (Zero) next_state = S_idle; else next_state = S_loaded;
    endcase
  end
endmodule
```

```
module t_Prob_8_22 ();
  parameter      m_size = 9;          // Width of datapath
  wire [2 * m_size - 1: 0] Product;
  wire          Ready;
  reg [m_size - 1: 0] Multiplicand, Multiplier;
  reg          Start, clock, reset_b;
  integer      Exp_Value;
  reg          Error;

  Prob_8_22 M0 (Product, Ready, Multiplicand, Multiplier, Start, clock, reset_b);

  initial #140000 $finish;
  initial begin clock = 0; #5 forever #5 clock = ~clock; end
  initial fork
    reset_b = 1;

    #2 reset_b = 0;
    #3 reset_b = 1;
  join
  initial begin #5 Start = 1; end
  always @ (posedge Ready) begin
    Exp_Value = Multiplier * Multiplicand;
    //Exp_Value = Multiplier * Multiplicand +1; // Inject error to confirm detection
  end
  always @ (negedge Ready) begin
    Error = (Exp_Value ^ Product);
  end

  initial begin
    #5 Multiplicand = 0;
    Multiplier = 0;
    repeat (64) #10 begin Multiplier = Multiplier + 1;
      repeat (64) @ (posedge M0.Ready) #5 Multiplicand = Multiplicand + 1;
    end
  end
endmodule
```

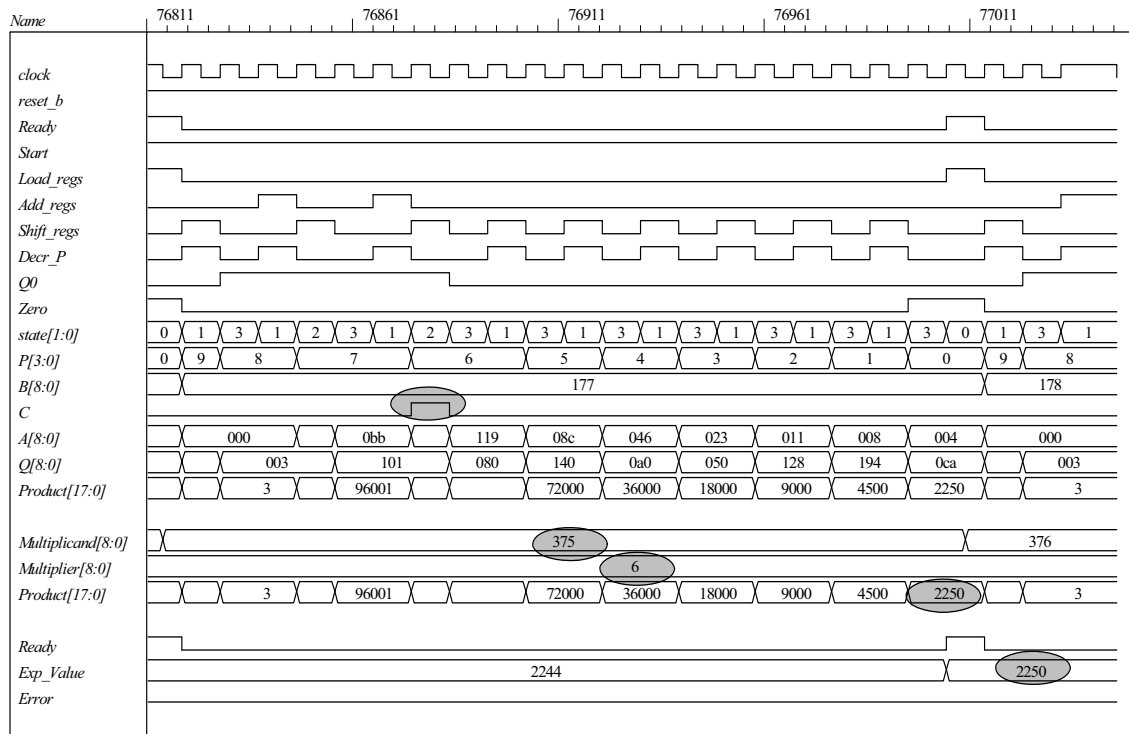

**8.23** As shown in Fig. P8.23 the machine asserts *Load\_regs* in state *S\_load*. This will cause the machine to operate incorrectly. Once *Load\_regs* is removed from *S\_load* the machine operates correctly. The state *S\_load* is a wasted state. Its removal leads to the same machine as shown in Fig. P8.15b.

```

module Prob_8_23 # (parameter m_size = 9)
(
  output [2*m_size -1: 0] Product,
  output Ready,
  input [m_size -1: 0] Multiplicand, Multiplier,
  input Start, clock, reset_b
);
wire [m_size -1: 0] A, Q;

assign Product = {A, Q};
wire Q0, Zero, Load_regs, Decr_P, Add_regs, Shift_regs;

```

```

Datapath_Unit M0 (A, Q, Q0, Zero, Multiplicand, Multiplier, Load_regs, Decr_P, Add_regs, Shift_regs,
clock, reset_b);
Control_Unit M1 (Ready, Decr_P, Shift_regs, Add_regs, Load_regs, Start, Q0, Zero, clock, reset_b);
endmodule

```

```

module Datapath_Unit # (parameter m_size = 9, BC_size = 4)
(
  output reg [m_size -1: 0] A, Q,
  output Q0, Zero,
  input [m_size -1: 0] Multiplicand, Multiplier,
  input Load_regs, Decr_P, Add_regs, Shift_regs, clock, reset_b
);
reg C;
reg [BC_size -1: 0] P;
reg [m_size -1: 0] B;

```

```
assign Q0 = Q[0];
assign Zero = (P == 0);

always @ (posedge clock, negedge reset_b)
if (reset_b == 0) begin
A <= 0;
C <= 0;
Q <= 0;
B <= 0;
P <= m_size;
end
else begin
if (Load_regs) begin
A <= 0;
C <= 0;
Q <= Multiplier;
B <= Multiplicand;
P <= m_size;
end
if (Decr_P) P <= P -1;
if (Add_regs) {C, A} <= A + B;
if (Shift_regs) {C, A, Q} <= {C, A, Q} >> 1;
end
endmodule

module Control_Unit (
output Ready, Decr_P, Shift_regs, output reg Add_regs, Load_regs, input Start, Q0, Zero, clock,
reset_b
);
reg [ 1: 0] state, next_state;
parameter S_idle = 2'b00, S_load = 2'b01, S_decr = 2'b10, S_shift = 2'b11;

assign Ready = (state == S_idle);
assign Shift_regs = (state == S_shift);
assign Decr_P = (state == S_decr);

always @ (posedge clock, negedge reset_b)
if (reset_b == 0) state <= S_idle; else state <= next_state;

always @ (state, Start, Q0, Zero) begin
next_state = S_idle;
Load_regs = 0;
Add_regs = 0;
case (state)
S_idle: if (Start == 0) next_state = S_idle; else begin next_state = S_load; Load_regs = 1; end
S_load: begin next_state = S_decr; end
S_decr: begin next_state = S_shift; if (Q0) Add_regs = 1; end
S_shift: if (Zero) next_state = S_idle; else next_state = S_load;
endcase
end
endmodule

module t_Prob_8_23 ();
parameter m_size = 9; // Width of datapath
wire [2 * m_size - 1: 0] Product;
wire Ready;
reg [m_size - 1: 0] Multiplicand, Multiplier;
reg Start, clock, reset_b;
integer Exp_Value;
reg Error;
```

Prob\_8\_23 M0 (Product, Ready, Multiplicand, Multiplier, Start, clock, reset\_b);

```
initial #140000 $finish;
initial begin clock = 0; #5 forever #5 clock = ~clock; end
initial fork
  reset_b = 1;

  #2 reset_b = 0;
  #3 reset_b = 1;
join
initial begin #5 Start = 1; end
always @ (posedge Ready) begin
  Exp_Value = Multiplier * Multiplicand;
  //Exp_Value = Multiplier * Multiplicand + 1; // Inject error to confirm detection
end
always @ (negedge Ready) begin
  Error = (Exp_Value ^ Product) ;
end

initial begin
  #5 Multiplicand = 0;
  Multiplier = 0;
  repeat (64) #10 begin Multiplier = Multiplier + 1;
    repeat (64) @ (posedge M0.Ready) #5 Multiplicand = Multiplicand + 1;
  end
end
endmodule
```

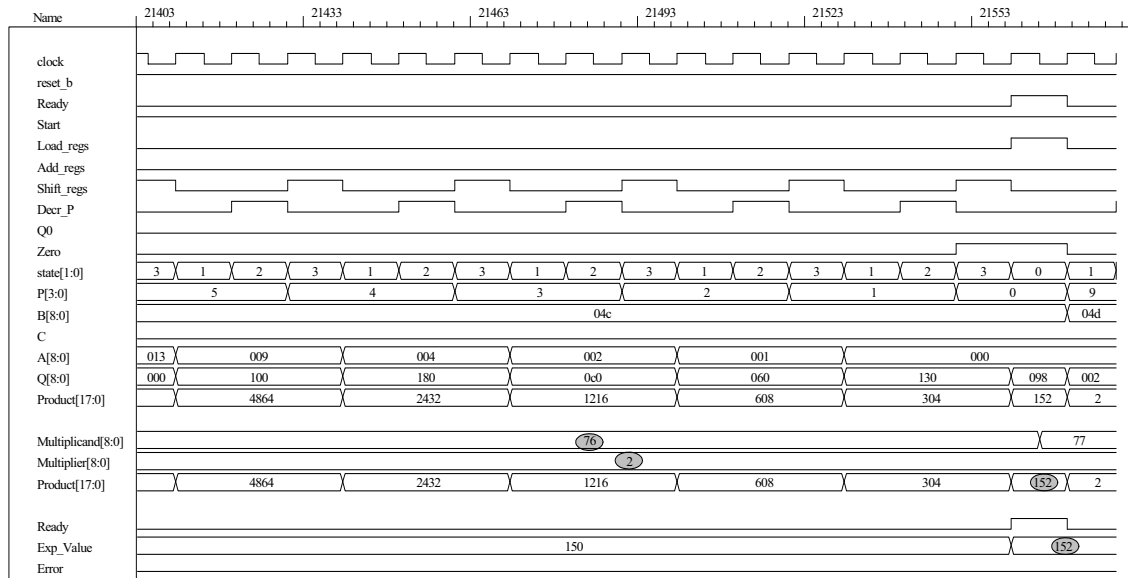

8.24

```
module Prob_8_24 # (parameter dp_width = 5)
(
  output [2*dp_width - 1: 0] Product,
  output Ready,
  input [dp_width - 1: 0] Multiplicand, Multiplier,
  input Start, clock, reset_b
);
  wire Load_regs, Decr_P, Add_regs, Shift_regs, Zero, Q0;

  Controller M0 (
    Ready, Load_regs, Decr_P, Add_regs, Shift_regs, Start, Zero, Q0,
    clock, reset_b
  );

  Datapath M1(Product, Q0, Zero, Multiplicand, Multiplier,
    Start, Load_regs, Decr_P, Add_regs, Shift_regs, clock, reset_b);
endmodule

module Controller (
  output Ready,
  output reg Load_regs, Decr_P, Add_regs, Shift_regs,
  input Start, Zero, Q0, clock, reset_b
);

  parameter S_idle = 3'b001, // one-hot code
            S_add = 3'b010,
            S_shift = 3'b100;

  reg [2: 0] state, next_state; // sized for one-hot
  assign Ready = (state == S_idle);

  always @ (posedge clock, negedge reset_b)
    if (~reset_b) state <= S_idle; else state <= next_state;

  always @ (state, Start, Q0, Zero) begin
    next_state = S_idle;
    Load_regs = 0;
    Decr_P = 0;
    Add_regs = 0;
    Shift_regs = 0;
    case (state)
      S_idle: if (Start) begin next_state = S_add; Load_regs = 1; end
      S_add: begin next_state = S_shift; Decr_P = 1; if (Q0) Add_regs = 1; end
      S_shift: begin
        Shift_regs = 1;
        if (Zero) next_state = S_idle;
        else next_state = S_add;
      end
      default: next_state = S_idle;
    endcase
  end
endmodule
```

```

module Datapath #(parameter dp_width = 5, BC_size = 3) (
  output [2*dp_width - 1: 0] Product, output Q0, output Zero,
  input [dp_width - 1: 0] Multiplicand, Multiplier,
  input Start, Load_regs, Decr_P, Add_regs, Shift_regs, clock, reset_b
);
// Default configuration: 5-bit datapath
reg [dp_width - 1: 0] A, B, Q; // Sized for datapath
reg C;
reg [BC_size - 1: 0] P; // Bit counter

assign Q0 = Q[0];
assign Zero = (P == 0); // Counter is zero
assign Product = {C, A, Q};
always @ (posedge clock, negedge reset_b)
  if (reset_b == 0) begin // Added to this solution, but
    P <= dp_width; // not really necessary since Load_regs
    B <= 0; // initializes the datapath
    C <= 0;
    A <= 0;
    Q <= 0;
  end
  else begin
    if (Load_regs) begin
      P <= dp_width;
      A <= 0;
      C <= 0;
      B <= Multiplicand;
      Q <= Multiplier;
    end
    if (Add_regs) {C, A} <= A + B;
    if (Shift_regs) {C, A, Q} <= {C, A, Q} >> 1;
    if (Decr_P) P <= P - 1;
  end
endmodule

module t_Prob_8_24;
  parameter dp_width = 5; // Width of datapath
  wire [2 * dp_width - 1: 0] Product;
  wire Ready;
  reg [dp_width - 1: 0] Multiplicand, Multiplier;
  reg Start, clock, reset_b;
  integer Exp_Value;
  reg Error;

  Prob_8_24 M0(Product, Ready, Multiplicand, Multiplier, Start, clock, reset_b);

  initial #115000 $finish;
  initial begin clock = 0; #5 forever #5 clock = ~clock; end
  initial fork
    reset_b = 1;
    #2 reset_b = 0;
    #3 reset_b = 1;
  join
  always @ (negedge Start) begin
    Exp_Value = Multiplier * Multiplicand;
    //Exp_Value = Multiplier * Multiplicand + 1; // Inject error to confirm detection
  end
  always @ (posedge Ready) begin
    # 1 Error <= (Exp_Value ^ Product) ;
  end

```



```

initial begin
    #5 Multiplicand = 0;
    Multiplier = 0;

    repeat (32) #10 begin
        Start = 1;
        #10 Start = 0;
        repeat (32) begin
            Start = 1;
            #10 Start = 0;
            #100 Multiplicand = Multiplicand + 1;
        end
        Multiplier = Multiplier + 1;
    end
end
endmodule
    
```

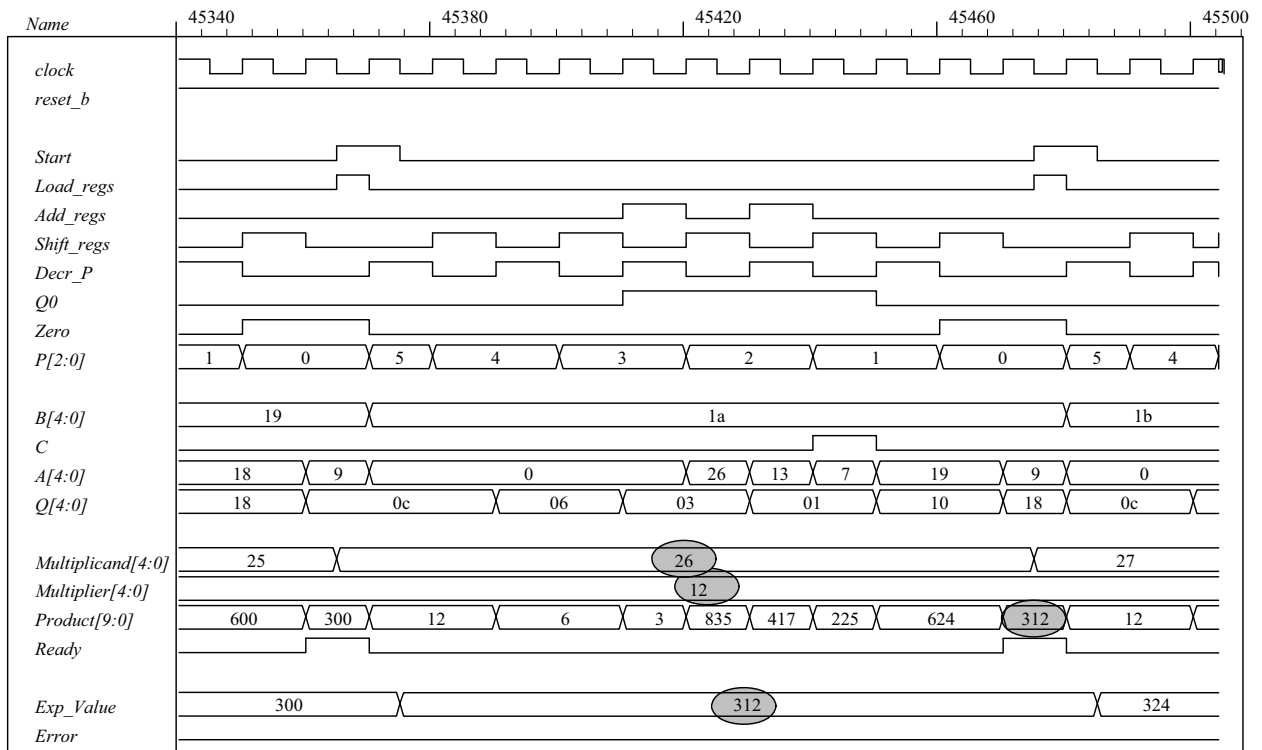

8.25 (a)

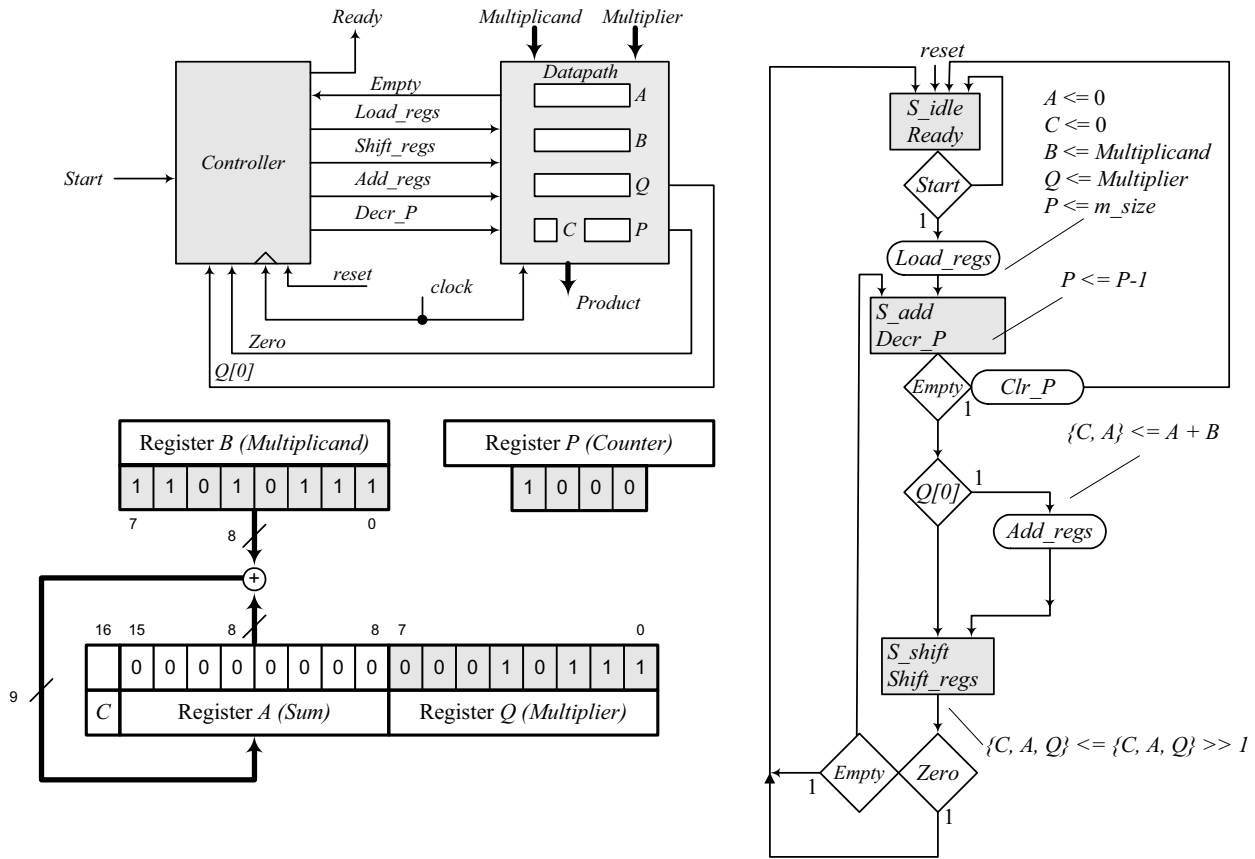

(b)  
 // The multiplier of Fig. 8.15 is modified to detect whether the multiplier or multiplicand are initially zero,  
 // and to detect whether the multiplier becomes zero before the entire multiplier has been applied  
 // to the multiplicand. Signal empty is generated by the datapath unit and used by the  
 // controller. Note that the bits of the product must be selected according to the stage at which  
 // termination occurs. The test for the condition of an empty multiplier is hardwired here for  
 // dp\_width = 5 because the range bounds of a vector must be defined by integer constants.  
 // This prevents development of a fully parameterized model.  
 // Note: the test bench has been modified.

```

module Prob_8_25 #(parameter dp_width = 5)
(
    output [2*dp_width - 1: 0] Product,
    output Ready,
    input [dp_width - 1: 0] Multiplicand, Multiplier,
    input Start, clock, reset_b
);
wire Load_regs, Decr_P, Add_regs, Shift_regs, Empty, Zero, Q0;
Controller M0 (
    Ready, Load_regs, Decr_P, Add_regs, Shift_regs, Start, Empty, Zero, Q0,
    clock, reset_b
);
Datapath M1(Product, Q0, Empty, Zero, Multiplicand, Multiplier,
    Start, Load_regs, Decr_P, Add_regs, Shift_regs, clock, reset_b);
endmodule
    
```

```

module Controller (
  output Ready,
  output reg Load_regs, Decr_P, Add_regs, Shift_regs,
  input Start, Empty, Zero, Q0, clock, reset_b
);

  parameter    BC_size = 3;    // Size of bit counter
  parameter    S_idle = 3'b001,    // one-hot code
               S_add = 3'b010,
               S_shift = 3'b100;

  reg [2: 0]    state, next_state;    // sized for one-hot
  assign       Ready = (state == S_idle);

  always @ (posedge clock, negedge reset_b)
    if (~reset_b) state <= S_idle; else state <= next_state;

  always @ (state, Start, Q0, Empty, Zero) begin
    next_state = S_idle;
    Load_regs = 0;
    Decr_P = 0;
    Add_regs = 0;
    Shift_regs = 0;
    case (state)
      S_idle:    if (Start) begin next_state = S_add; Load_regs = 1; end
      S_add:    begin next_state = S_shift; Decr_P = 1; if (Q0) Add_regs = 1; end
      S_shift:  begin
        Shift_regs = 1;
        if (Zero) next_state = S_idle;
        else if (Empty) next_state = S_idle;
        else next_state = S_add;
      end
      default: next_state = S_idle;
    endcase
  end
endmodule

module Datapath #(parameter dp_width = 5, BC_size = 3) (
  output reg [2*dp_width - 1: 0] Product, output Q0, output Empty, output Zero,
  input [dp_width - 1: 0] Multiplicand, Multiplier,
  input Start, Load_regs, Decr_P, Add_regs, Shift_regs, clock, reset_b
);
  // Default configuration: 5-bit datapath
  parameter    S_idle = 3'b001,    // one-hot code
               S_add = 3'b010,
               S_shift = 3'b100;

  reg [dp_width - 1: 0]    A, B, Q;    // Sized for datapath
  reg                    C;
  reg [BC_size - 1: 0]    P;    // Bit counter
  wire [2*dp_width -1: 0] Internal_Product = {C, A, Q};

  assign       Q0 = Q[0];
  assign       Zero = (P == 0);    // Bit counter is zero

  always @ (posedge clock, negedge reset_b)
    if (reset_b == 0) begin    // Added to this solution, but
      P <= dp_width;    // not really necessary since Load_regs
      B <= 0;    // initializes the datapath
      C <= 0;
      A <= 0;
      Q <= 0;
    end

```

```

else begin
if (Load_regs) begin
P <= dp_width;
A <= 0;
C <= 0;
B <= Multiplicand;
Q <= Multiplier;
end
if (Add_regs) {C, A} <= A + B;
if (Shift_regs) {C, A, Q} <= {C, A, Q} >> 1;
if (Decr_P) P <= P -1;
end
// Status signals
reg Empty_multiplier;
wire Empty_multiplicand = (Multiplicand == 0);
assign Empty = Empty_multiplicand || Empty_multiplier;

always @ (P, Internal_Product) begin// Note: hardwired for dp_width 5
Product = 0;
case (P) // Examine multiplier bits
0: Product = Internal_Product;
1: Product = Internal_Product [2*dp_width -1: 1];
2: Product = Internal_Product [2*dp_width -1: 2];
3: Product = Internal_Product [2*dp_width -1: 3];
4: Product = Internal_Product [2*dp_width -1: 4];
5: Product = 0;
endcase
end

always @ (P, Q) begin // Note: hardwired for dp_width 5
Empty_multiplier = 0;
case (P)
0: Empty_multiplier = 1;
1: if (Q[1] == 0) Empty_multiplier = 1;
2: if (Q[2: 1] == 0) Empty_multiplier = 1;
3: if (Q[3: 1] == 0) Empty_multiplier = 1;
4: if (Q[4: 1] == 0) Empty_multiplier = 1;
5: if (Q[5: 1] == 0) Empty_multiplier = 1;
default: Empty_multiplier = 1'bx;
endcase
end
endmodule

module t_Prob_8_25;
parameter dp_width = 5; // Width of datapath
wire [2 * dp_width - 1: 0] Product;
wire Ready;
reg [dp_width - 1: 0] Multiplicand, Multiplier;
reg Start, clock, reset_b;
integer Exp_Value;
reg Error;

Prob_8_25 M0(Product, Ready, Multiplicand, Multiplier, Start, clock, reset_b);

initial #115000 $finish;
initial begin clock = 0; #5 forever #5 clock = ~clock; end
initial fork
reset_b = 1;
#2 reset_b = 0;
#3 reset_b = 1;
join

```

```

always @ (negedge Start) begin
    Exp_Value = Multiplier * Multiplicand;
    //Exp_Value = Multiplier * Multiplicand + 1; // Inject error to confirm detection
end
always @ (posedge Ready) begin
    # 1 Error <= (Exp_Value ^ Product) ;
end

initial begin
    #5 Multiplicand = 0;
    Multiplier = 0;

repeat (32) #10 begin
    Start = 1;
    #10 Start = 0;
    repeat (32) begin
        Start = 1;
        #10 Start = 0;
        #100 Multiplicand = Multiplicand + 1;
    end
    Multiplier = Multiplier + 1;
end
end
endmodule

```

(c) Test plan: Exhaustively test all combinations of multiplier and multiplicand, using automatic error checking. Verify that early termination is implemented. Sample of simulation results is shown below.

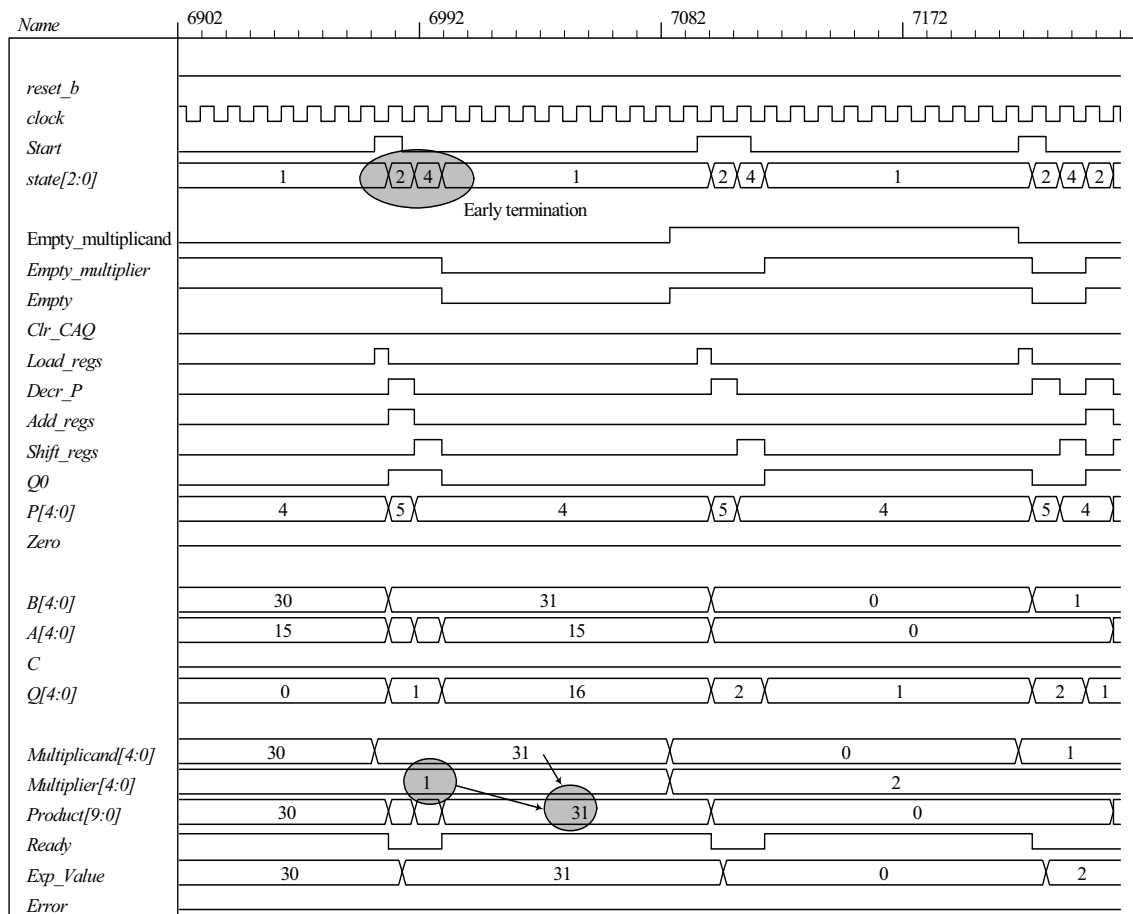

8.26

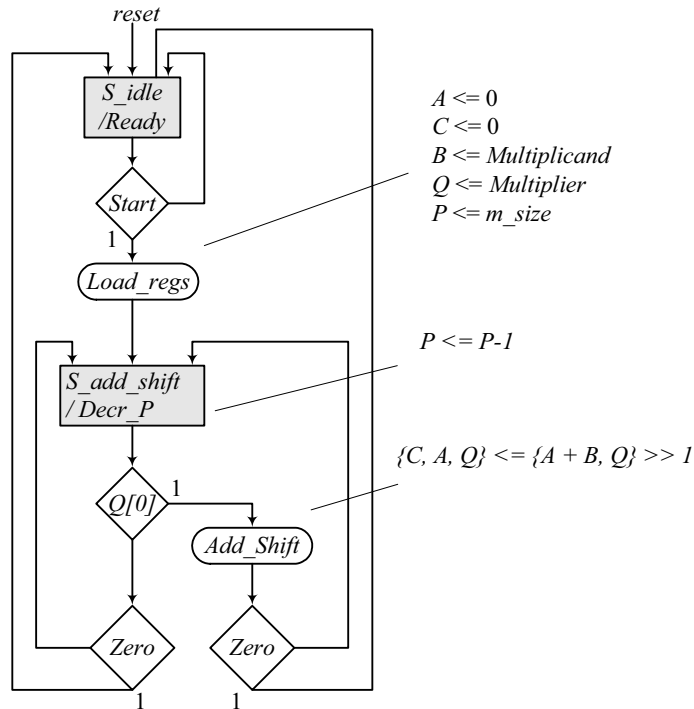

```

module Prob_8_26 (Product, Ready, Multiplicand, Multiplier, Start, clock, reset_b);
// Default configuration: 5-bit datapath
parameter dp_width = 5; // Set to width of datapath
output [2*dp_width - 1: 0] Product;
output Ready;
input [dp_width - 1: 0] Multiplicand, Multiplier;
input Start, clock, reset_b;
parameter BC_size = 3; // Size of bit counter
parameter S_idle = 2'b01, // one-hot code
S_add_shift = 2'b10;

reg [2: 0] state, next_state;
reg [dp_width - 1: 0] A, B, Q; // Sized for datapath
reg C;
reg [BC_size - 1: 0] P;
reg Load_regs, Decr_P, Add_shift, Shift;
assign Product = {C, A, Q};
wire Zero = (P == 0); // counter is zero
wire Ready = (state == S_idle); // controller status

// control unit
always @ (posedge clock, negedge reset_b)
if (~reset_b) state <= S_idle; else state <= next_state;

always @ (state, Start, Q[0], Zero) begin
next_state = S_idle;
Load_regs = 0;
Decr_P = 0;
Add_shift = 0;
Shift = 0;
case (state)
S_idle: begin if (Start) next_state = S_add_shift; Load_regs = 1; end

```

```
S_add_shift:      begin
                   Decr_P = 1;
                   if (Zero) next_state = S_idle;
                   else begin
                       next_state = S_add_shift;
                       if (Q[0]) Add_shift = 1; else Shift = 1;
                   end
                   end
                   end
default:          next_state = S_idle;
endcase
end

// datapath unit
always @ (posedge clock) begin
    if (Load_regs) begin
        P <= dp_width;
        A <= 0;
        C <= 0;
        B <= Multiplicand;
        Q <= Multiplier;
    end
    if (Decr_P) P <= P - 1;
    if (Add_shift) {C, A, Q} <= {C, A+B, Q} >> 1;
    if (Shift) {C, A, Q} <= {C, A, Q} >> 1;
end
endmodule

module t_Prob_8_26;
    parameter      dp_width = 5;           // Width of datapath
    wire [2 * dp_width - 1: 0] Product;
    wire           Ready;
    reg [dp_width - 1: 0] Multiplicand, Multiplier;
    reg            Start, clock, reset_b;
    integer        Exp_Value;
    wire           Error;

    Prob_8_26 M0 (Product, Ready, Multiplicand, Multiplier, Start, clock, reset_b);

    initial #70000 $finish;
    initial begin clock = 0; #5 forever #5 clock = ~clock; end
    initial fork
        reset_b = 1;
        #2 reset_b = 0;
        #3 reset_b = 1;
    join
    initial begin #5 Start = 1; end
    always @ (posedge Ready) begin
        Exp_Value = Multiplier * Multiplicand;
    end
    assign Error = Ready & (Exp_Value ^ Product);
    initial begin
        #5 Multiplicand = 0;
        Multiplier = 0;
        repeat (32) #10 begin Multiplier = Multiplier + 1;
            repeat (32) @ (posedge M0.Ready) #5 Multiplicand = Multiplicand + 1;
        end
    end
end
endmodule
```

Sample of simulation results.

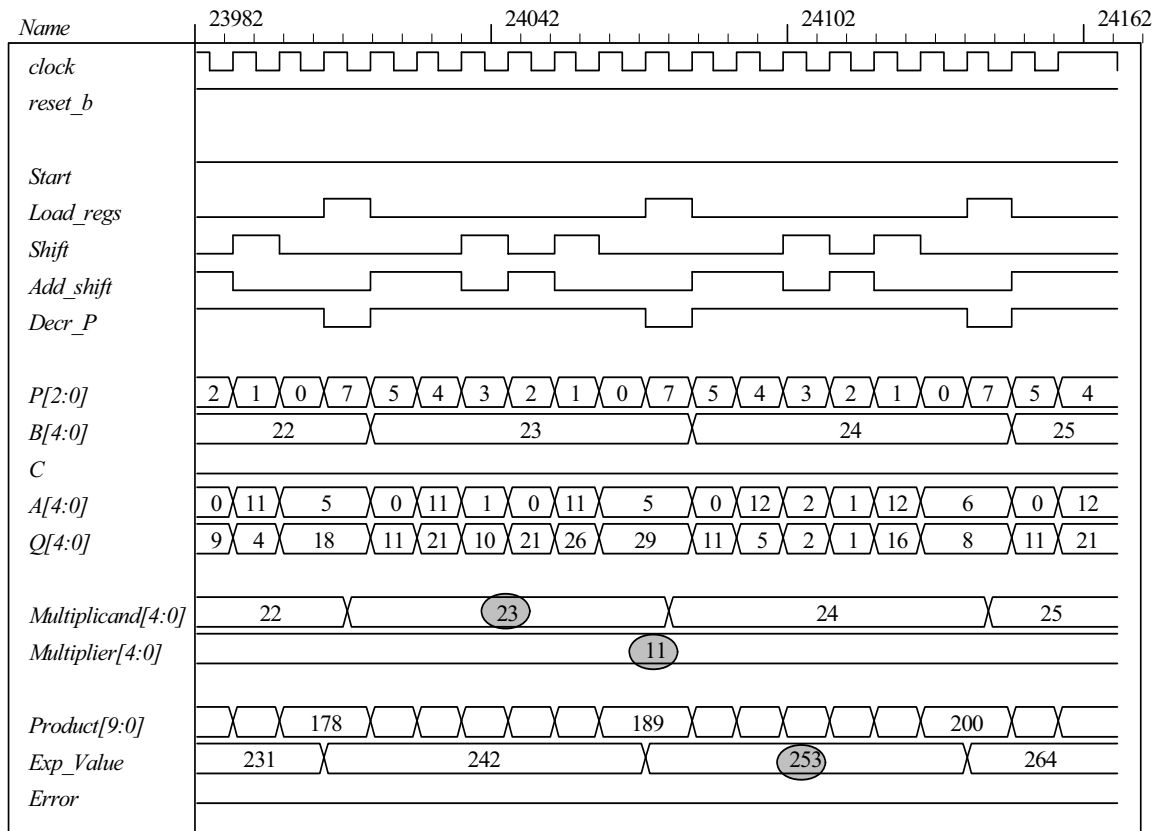

8.27

(a)

```
// Test bench for exhaustive simulation
module t_Sequential_Binary_Multiplier;
  parameter dp_width = 5; // Width of datapath
  wire [2 * dp_width - 1: 0] Product;
  wire Ready;
  reg [dp_width - 1: 0] Multiplicand, Multiplier;
  reg Start, clock, reset_b;

  Sequential_Binary_Multiplier M0 (Product, Ready, Multiplicand, Multiplier, Start, clock, reset_b);

  initial #109200 $finish;
  initial begin clock = 0; #5 forever #5 clock = ~clock; end
  initial fork
    reset_b = 1;
    #2 reset_b = 0;
    #3 reset_b = 1;
  join
  initial begin #5 Start = 1; end
  initial begin
    #5 Multiplicand = 0;
    Multiplier = 0;
    repeat (31) #10 begin Multiplier = Multiplier + 1;
    repeat (32) @ (posedge M0.Ready) #5 Multiplicand = Multiplicand + 1;
    end
    Start = 0;
  end
end

// Error Checker
```



```

reg Error;
reg [2*dp_width - 1: 0] Exp_Value;
always @ (posedge Ready) begin
    Exp_Value = Multiplier * Multiplicand;
    //Exp_Value = Multiplier * Multiplicand + 1;    // Inject error to verify detection
    Error = (Exp_Value ^ Product);
end
endmodule

module Sequential_Binary_Multiplier (Product, Ready, Multiplicand, Multiplier, Start, clock, reset_b);
// Default configuration: 5-bit datapath
parameter dp_width = 5;    // Set to width of datapath
output [2*dp_width - 1: 0] Product;
output Ready;
input [dp_width - 1: 0] Multiplicand, Multiplier;
input Start, clock, reset_b;

parameter BC_size = 3; // Size of bit counter
parameter S_idle = 3'b001, // one-hot code
            S_add = 3'b010,
            S_shift = 3'b100;

reg [2: 0] state, next_state;
reg [dp_width - 1: 0] A, B, Q;    // Sized for datapath
reg C;
reg [BC_size - 1: 0] P;
reg Load_regs, Decr_P, Add_regs, Shift_regs;

// Miscellaneous combinational logic

assign Product = {C, A, Q};
wire Zero = (P == 0);    // counter is zero
wire Ready = (state == S_idle);    // controller status

// control unit

always @ (posedge clock, negedge reset_b)
    if (~reset_b) state <= S_idle; else state <= next_state;

always @ (state, Start, Q[0], Zero) begin
    next_state = S_idle;
    Load_regs = 0;
    Decr_P = 0;
    Add_regs = 0;
    Shift_regs = 0;
    case (state)
        S_idle: begin if (Start) next_state = S_add; Load_regs = 1; end
        S_add: begin next_state = S_shift; Decr_P = 1; if (Q[0]) Add_regs = 1; end
        S_shift: begin Shift_regs = 1; if (Zero) next_state = S_idle;
        else next_state = S_add; end
        default: next_state = S_idle;
    endcase
end

```

// datapath unit

```

always @ (posedge clock) begin
  if (Load_regs) begin
    P <= dp_width;
    A <= 0;
    C <= 0;
    B <= Multiplicand;
    Q <= Multiplier;
  end
  end
  if (Add_regs) {C, A} <= A + B;
  if (Shift_regs) {C, A, Q} <= {C, A, Q} >> 1;
  if (Decr_P) P <= P -1;
end
endmodule

```

Sample of simulation results:

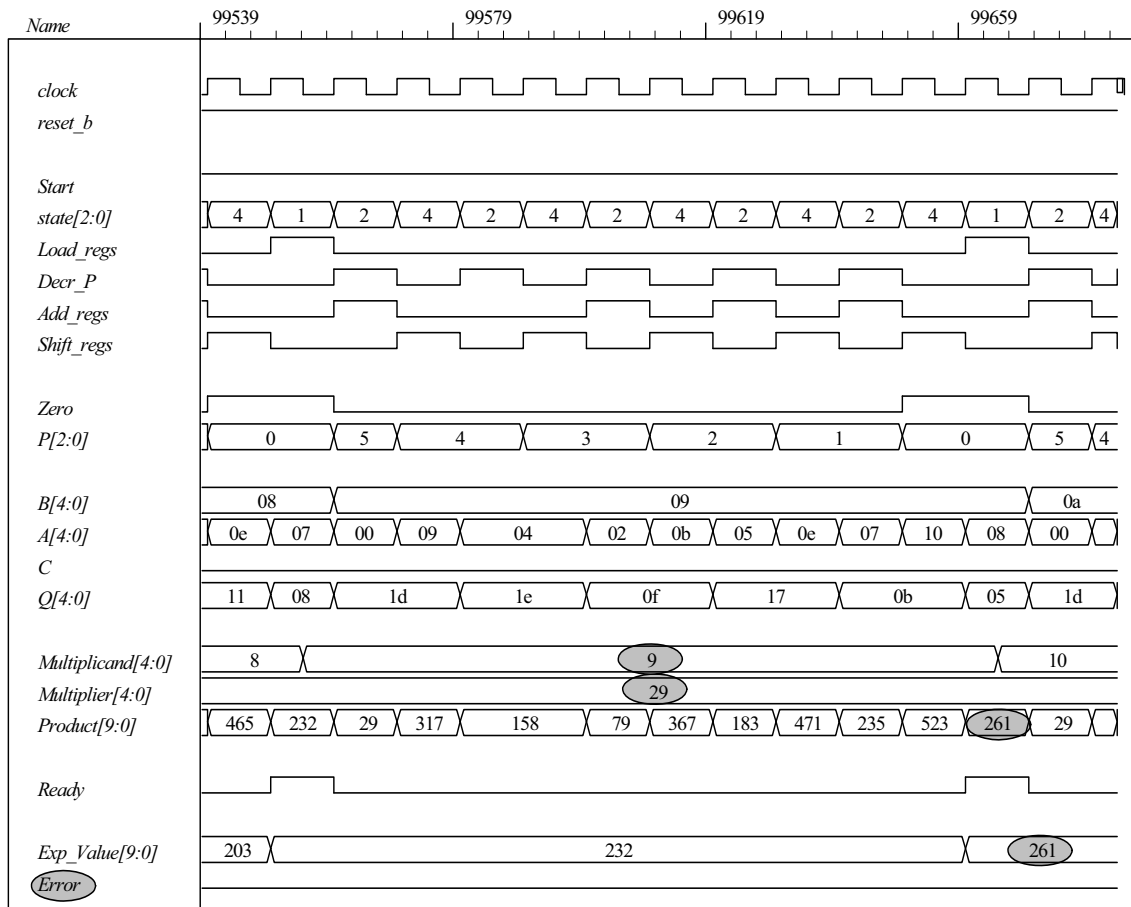

- (b) In this part the controller is described by Fig. 8.18. The test bench includes probes to display the state of the controller.

```
// Test bench for exhaustive simulation
module t_Sequential_Binary_Multiplier;
parameter dp_width = 5; // Width of datapath
wire [2 * dp_width - 1: 0] Product;
wire Ready;
reg [dp_width - 1: 0] Multiplicand, Multiplier;
reg Start, clock, reset_b;

Sequential_Binary_Multiplier M0 (Product, Ready, Multiplicand, Multiplier, Start, clock, reset_b);

initial #109200 $finish;
initial begin clock = 0; #5 forever #5 clock = ~clock; end
initial fork
    reset_b = 1;
    #2 reset_b = 0;
    #3 reset_b = 1;
join
initial begin #5 Start = 1; end
initial begin
    #5 Multiplicand = 0;
    Multiplier = 0;
    repeat (31) #10 begin Multiplier = Multiplier + 1;
        repeat (32) @ (posedge M0.Ready) #5 Multiplicand = Multiplicand + 1;
    end
    Start = 0;
end

// Error Checker
reg Error;
reg [2*dp_width -1: 0] Exp_Value;
always @ (posedge Ready) begin
    Exp_Value = Multiplier * Multiplicand;
    //Exp_Value = Multiplier * Multiplicand + 1; // Inject error to verify detection
    Error = (Exp_Value ^ Product);
end

wire [2: 0] state = {M0.G2, M0.G1, M0.G0};
endmodule

module Sequential_Binary_Multiplier (Product, Ready, Multiplicand, Multiplier, Start, clock, reset_b);
// Default configuration: 5-bit datapath
parameter dp_width = 5; // Set to width of datapath
output [2*dp_width - 1: 0] Product;
output Ready;
input [dp_width - 1: 0] Multiplicand, Multiplier;
input Start, clock, reset_b;

parameter BC_size = 3; // Size of bit counter
reg [dp_width - 1: 0] A, B, Q; // Sized for datapath
reg C;
reg [BC_size - 1: 0] P;
wire Load_regs, Decr_P, Add_regs, Shift_regs;
```

```
// Status signals

assign      Product = {C, A, Q};
wire       Zero = (P == 0);      // counter is zero
wire       Q0 = Q[0];

// One-Hot Control unit (See Fig. 8.18)
DFF_S M0 (G0, D0, clock, Set);
DFF M1 (G1, D1, clock, reset_b);
DFF M2 (G2, G1, clock, reset_b);
or (D0, w1, w2);
and (w1, G0, Start_b);
and (w2, Zero, G2);
not (Start_b, Start);
not (Zero_b, Zero);
or (D1, w3, w4);
and (w3, Start, G0);
and (w4, Zero_b, G2);

and (Load_regs, G0, Start);
and (Add_regs, Q0, G1);
assign Ready = G0;
assign Decr_P = G1;
assign Shift_regs = G2;
not (Set, reset_b);

// datapath unit

always @ (posedge clock) begin
  if (Load_regs) begin
    P <= dp_width;
    A <= 0;
    C <= 0;
    B <= Multiplicand;
    Q <= Multiplier;
  end
  if (Add_regs) {C, A} <= A + B;
  if (Shift_regs) {C, A, Q} <= {C, A, Q} >> 1;
  if (Decr_P) P <= P -1;
end
endmodule

module DFF_S (output reg Q, input data, clock, Set);
  always @ (posedge clock, posedge Set)
    if (Set) Q <= 1'b1; else Q <= data;
endmodule

module DFF (output reg Q, input data, clock, reset_b);
  always @ (posedge clock, negedge reset_b)
    if (reset_b == 0) Q <= 1'b0; else Q <= data;
endmodule
```

Sample of simulation results:

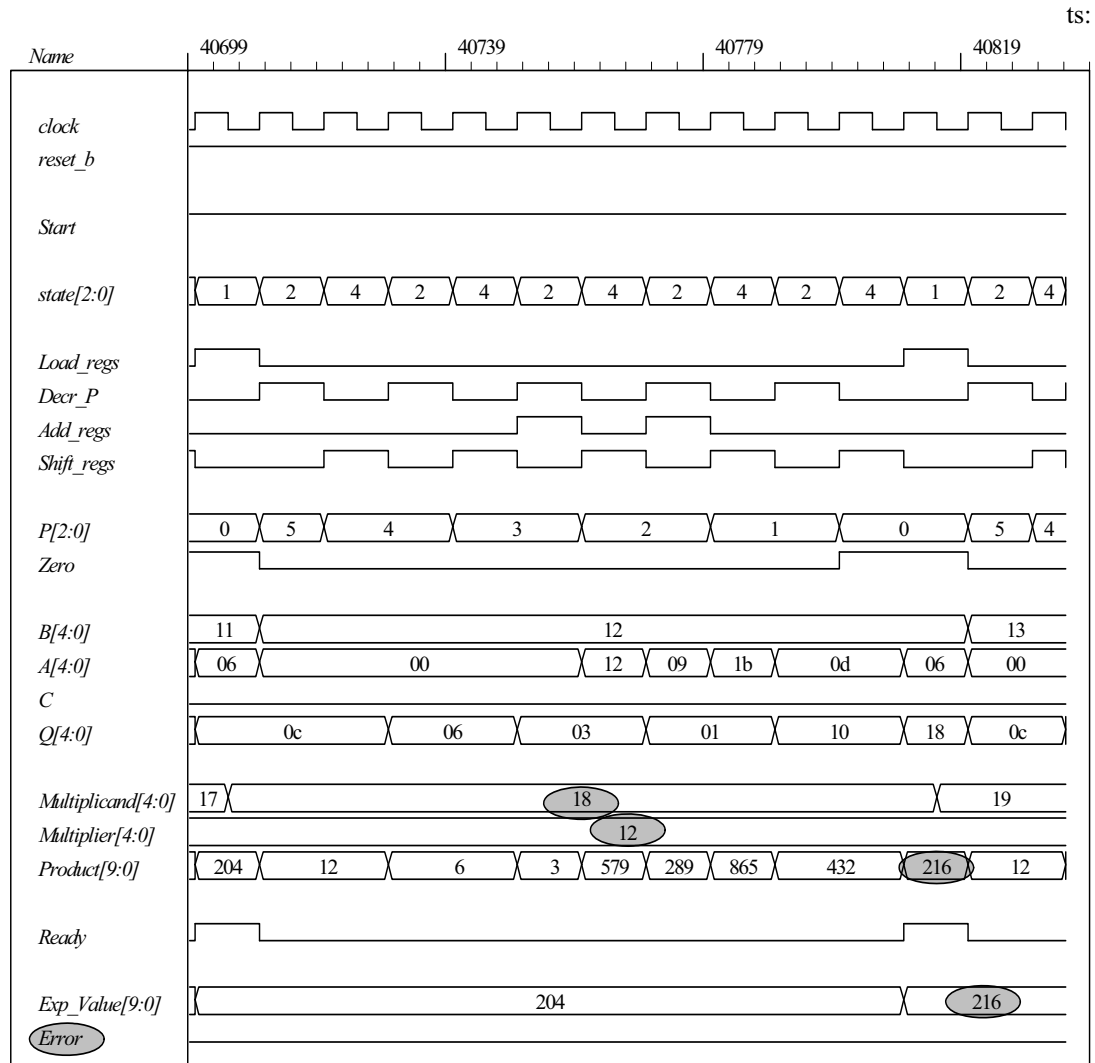

8.28

```
// Test bench for exhaustive simulation
module t_Sequential_Binary_Multiplier;
  parameter dp_width = 5; // Width of datapath
  wire [2 * dp_width - 1: 0] Product;
  wire Ready;
  reg [dp_width - 1: 0] Multiplicand, Multiplier;
  reg Start, clock, reset_b;

  Sequential_Binary_Multiplier M0 (Product, Ready, Multiplicand, Multiplier, Start, clock, reset_b);

  initial #109200 $finish;
  initial begin clock = 0; #5 forever #5 clock = ~clock; end
  initial fork
    reset_b = 1;
    #2 reset_b = 0;
    #3 reset_b = 1;
  join
```

```

initial begin #5 Start = 1; end
initial begin
    #5 Multiplicand = 0;
    Multiplier = 0;
    repeat (31) #10 begin Multiplier = Multiplier + 1;
        repeat (32) @ (posedge M0.Ready) #5 Multiplicand = Multiplicand + 1;
    end
    Start = 0;
end

// Error Checker
reg Error;
reg [2*dp_width -1: 0] Exp_Value;
always @ (posedge Ready) begin
    Exp_Value = Multiplier * Multiplicand;
    //Exp_Value = Multiplier * Multiplicand + 1;    // Inject error to verify detection
    Error = (Exp_Value ^ Product);
end
wire [2: 0] state = {M0.M0.G2, M0.M0.G1, M0.M0.G0}; // Watch state
endmodule

module Sequential_Binary_Multiplier
    #(parameter dp_width = 5)
    (
        output [2*dp_width -1: 0] Product,
        output Ready,
        input [dp_width -1: 0] Multiplicand, Multiplier,
        input Start, clock, reset_b
    );
    wire Load_regs, Decr_P, Add_regs, Shift_regs, Zero, Q0;

    Controller M0 (Ready, Load_regs, Decr_P, Add_regs, Shift_regs, Start, Zero, Q0, clock, reset_b);
    Datapath M1(Product, Q0, Zero, Multiplicand, Multiplier, Start, Load_regs, Decr_P, Add_regs,
        Shift_regs, clock, reset_b);
endmodule

module Controller (
    output Ready,
    output Load_regs, Decr_P, Add_regs, Shift_regs,
    input Start, Zero, Q0, clock, reset_b
);
// One-Hot Control unit (See Fig. 8.18)
DFF_S M0 (G0, D0, clock, Set);
DFF M1 (G1, D1, clock, reset_b);
DFF M2 (G2, G1, clock, reset_b);
or (D0, w1, w2);
and (w1, G0, Start_b);
and (w2, Zero, G2);
not (Start_b, Start);
not (Zero_b, Zero);
or (D1, w3, w4);
and (w3, Start, G0);
and (w4, Zero_b, G2);

and (Load_regs, G0, Start);
and (Add_regs, Q0, G1);
assign Ready = G0;
assign Decr_P = G1;
assign Shift_regs = G2;
not (Set, reset_b);
endmodule

```

```
module Datapath #(parameter dp_width = 5, BC_size = 3) (  
  output [2*dp_width - 1: 0] Product, output Q0, output Zero,  
  input [dp_width - 1: 0] Multiplicand, Multiplier,  
  input Start, Load_regs, Decr_P, Add_regs, Shift_regs, clock, reset_b  
);  
  reg [dp_width - 1: 0] A, B, Q; // Sized for datapath  
  reg C;  
  reg [BC_size - 1: 0] P;  
  assign Product = {C, A, Q};  
  // Status signals  
  assign Zero = (P == 0); // counter is zero  
  assign Q0 = Q[0];  
  
  always @ (posedge clock) begin  
    if (Load_regs) begin  
      P <= dp_width;  
      A <= 0;  
      C <= 0;  
      B <= Multiplicand;  
      Q <= Multiplier;  
    end  
    if (Add_regs) {C, A} <= A + B;  
    if (Shift_regs) {C, A, Q} <= {C, A, Q} >> 1;  
    if (Decr_P) P <= P - 1;  
  end  
endmodule  
  
module DFF_S (output reg Q, input data, clock, Set);  
  always @ ( posedge clock, posedge Set)  
    if (Set) Q <= 1'b1; else Q <= data;  
endmodule  
module DFF (output reg Q, input data, clock, reset_b);  
  always @ ( posedge clock, negedge reset_b)  
    if (reset_b == 0) Q <= 1'b0; else Q <= data;  
endmodule
```

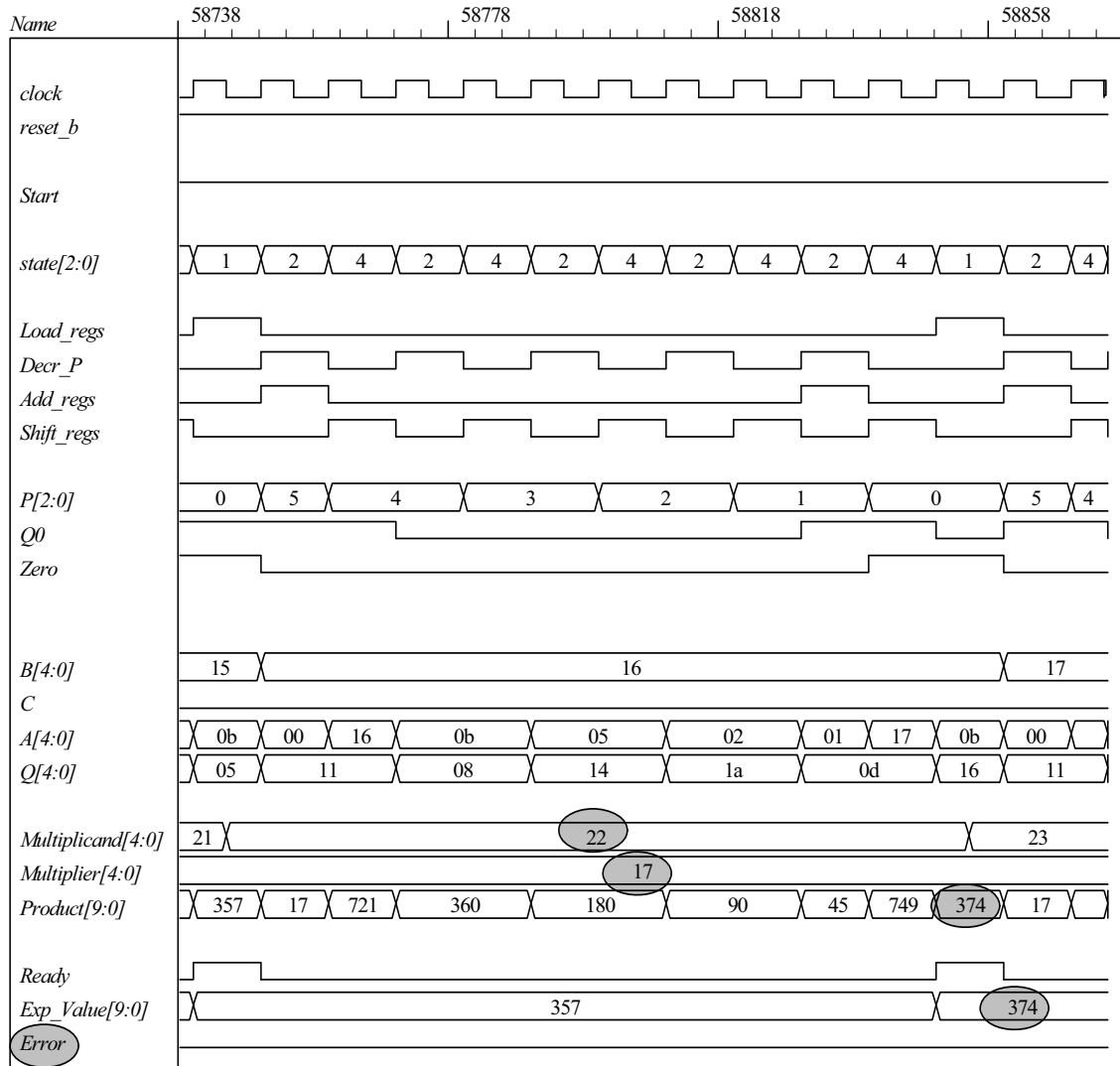

8.29 (a)

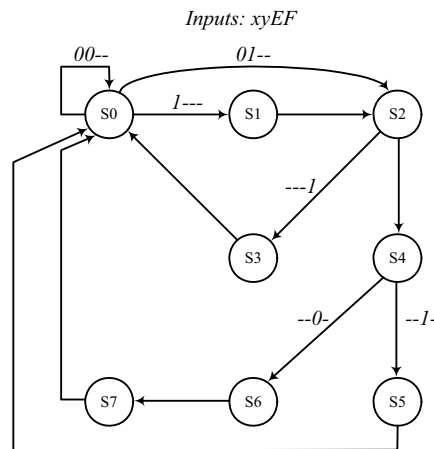



(b)

$$DS_0 = x'y'S_0 + S_3 + S_5 + S_7$$

$$DS_1 = xS_0$$

$$DS_2 = x'yS_0 + S_1$$

$$DS_3 = FS_2$$

$$DS_4 = F'S_2$$

$$DS_5 = E'S_5$$

$$DS_6 = E'S_4$$

$$DS_7 = S_6$$

(c)

Output	Present state	Inputs	Next state
	$G_1 G_2 G_3$	$x y E F$	$G_1 G_2 G_3$
$S_0$	0 0 0	0 0 x x	0 0 0
$S_0$	0 0 0	1 x x x	0 0 1
$S_0$	0 0 0	0 1 x x	0 1 0
$S_1$	0 0 1	x x x x	0 1 0
$S_2$	0 1 0	x x 0 x	1 0 0
$S_2$	0 1 0	x x 1 x	0 1 1
$S_3$	0 1 1	x x x x	0 0 0
$S_4$	1 0 0	x x x 0	1 1 0
$S_4$	1 0 0	x x x 1	1 0 1
$S_5$	1 0 1	x x x x	0 0 0
$S_6$	1 1 0	x x x x	1 1 0
$S_7$	1 1 1	x x x x	0 0 0

(d)

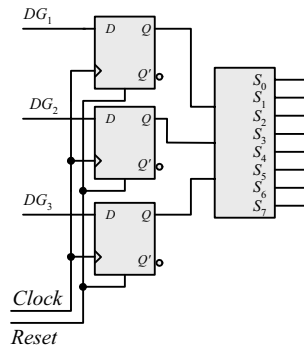

$$DG_1 = F'S_2 + S_4 + S_6$$

$$DG_2 = x'y'S_0 + S_1 + FS_2 + E'S_4 + S_6$$

$$DG_3 = xS_0 + FS_2 + ES_4 + S_6$$

(e)

Present state $G_1 G_2 G_3$	Next state $G_1 G_2 G_3$	Input conditions	Mux1	Mux2	Mux3
0 0 0 0 0 0 0 0 0	0 0 0 0 0 1 0 1 0	$x'y'$ $x$ $x'y$	0	$x'y$	$x$
0 0 1	0 1 0	None	0	1	0
0 1 0 0 1 0	1 0 0 0 1 1	$F'$ $F'$	$F'$	$F$	$F$
0 1 1	0 0 0	None	0	0	0
1 0 0 1 0 0	1 1 0 1 0 1	$E'$ $E'$	1	$E'$	$E$
1 0 1	0 0 0	None	0	0	0
1 1 0	1 1 0	None	1	1	1
1 1 1	0 0 0	None	0	0	0

(f)

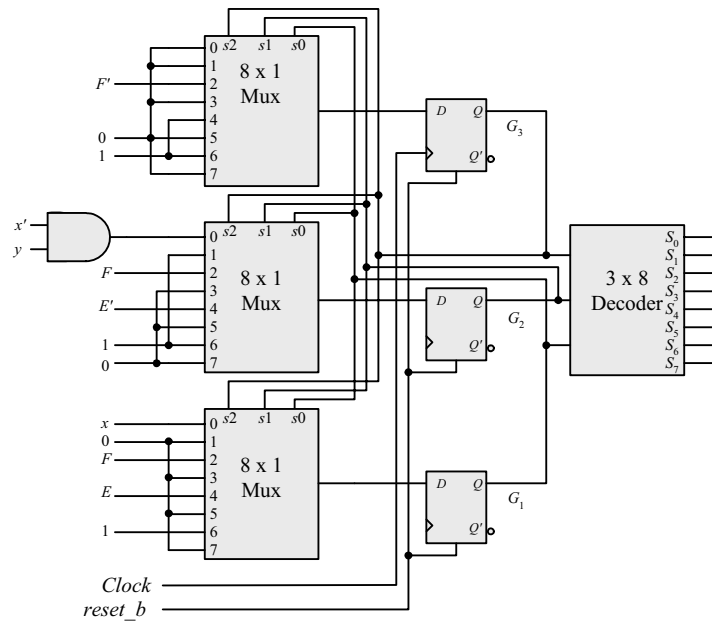

(g)

**module** Controller\_8\_29g (input x, y, E, F, clock, reset\_b);

supply0 GND;

supply1 VCC;

mux\_8x1 M3 (m3, GND, GND, F\_bar, GND, VCC, GND, VCC, GND, G3, G2, G1);

mux\_8x1 M2 (m2, w1, VCC, F, GND, E\_bar, GND, VCC, GND, G3, G2, G1);

mux\_8x1 M1 (m1, x, GND, F, GND, E, GND, VCC, GND, G3, G2, G1);

DFF\_8\_28g DM3 (G3, m3, clock, reset\_b);

DFF\_8\_28g DM2 (G2, m2, clock, reset\_b);

DFF\_8\_28g DM1 (G1, m1, clock, reset\_b);

decoder\_3x8 M0\_D (y0, y1, y2, y3, y4, y5, y6, y7, G3, G2, G1);

```
    and (w1, x_bar, y);
    not (F_bar, F);
    not (E_bar, E);
    not (x_bar, x);
endmodule

// Test plan: Exercise all paths of the ASM chart

module t_Controller_8_29g ();
    reg x, y, E, F, clock, reset_b;
    Controller_8_29g M0 (x, y, E, F, clock, reset_b);
    wire [2: 0] state = {M0.G3, M0.G2, M0.G1};

    initial #500 $finish;
    initial begin clock = 0; forever #5 clock = ~clock; end
    initial begin end
    initial fork
        reset_b = 0; #2 reset_b = 1;
        #0 begin x = 1; y = 1; E = 1; F = 1; end // Path: S_0, S_1, S_2, S_34
        #80 reset_b = 0; #92 reset_b = 1;
        #90 begin x = 1; y = 1; E = 1; F = 0; end
        #150 reset_b = 0;
        #152 reset_b = 1;
        #150 begin x = 1; y = 1; E = 0; F = 0; end // Path: S_0, S_1, S_2, S_4, S_5
        #200 reset_b = 0;
        #202 reset_b = 1;
        #190 begin x = 1; y = 1; E = 0; F = 0; end // Path: S_0, S_1, S_2, S_4, S_6, S_7
        #250 reset_b = 0;
        #252 reset_b = 1;
        #240 begin x = 0; y = 0; E = 0; F = 0; end // Path: S_0
        #290 reset_b = 0;
        #292 reset_b = 1;
        #280 begin x = 0; y = 1; E = 0; F = 0; end // Path: S_0, S_2, S_4, S_6, S_7
        #360 reset_b = 0;
        #362 reset_b = 1;
        #350 begin x = 0; y = 1; E = 1; F = 0; end // Path: S_0, S_2, S_4, S_5
        #420 reset_b = 0;
        #422 reset_b = 1;
        #410 begin x = 0; y = 1; E = 0; F = 1; end // Path: S_0, S_2, S_3
    join
endmodule

module mux_8x1 (output reg y, input x0, x1, x2, x3, x4, x5, x6, x7, s2, s1, s0);
    always @ (x0, x1, x2, x3, x4, x5, x6, x7, s0, s1, s2)
        case ({s2, s1, s0})
            3'b000: y = x0;
            3'b001: y = x1;
            3'b010: y = x2;
            3'b011: y = x3;
            3'b100: y = x4;
            3'b101: y = x5;
            3'b110: y = x6;
            3'b111: y = x7;
        endcase
endmodule

module DFF_8_28g (output reg q, input data, clock, reset_b);
    always @ (posedge clock, negedge reset_b)
        if (!reset_b) q <= 1'b0; else q <= data;
endmodule
```

```
module decoder_3x8 (output reg y0, y1, y2, y3, y4, y5, y6, y7, input x2, x1, x0);  
always @ (x0, x1, x2) begin  
  {y7, y6, y5, y4, y3, y2, y1, y0} = 8'b0;  
  case ({x2, x1, x0})  
    3'b000: y0= 1'b1;  
    3'b001: y1= 1'b1;  
    3'b010: y2= 1'b1;  
    3'b011: y3= 1'b1;  
    3'b100: y4= 1'b1;  
    3'b101: y5= 1'b1;  
    3'b110: y6= 1'b1;  
    3'b111: y7= 1'b1;  
  endcase  
end  
endmodule
```

Path: S\_0, S\_1, S\_2, S\_3 and Path: S\_0, S\_1, S\_2, S\_4, S\_5

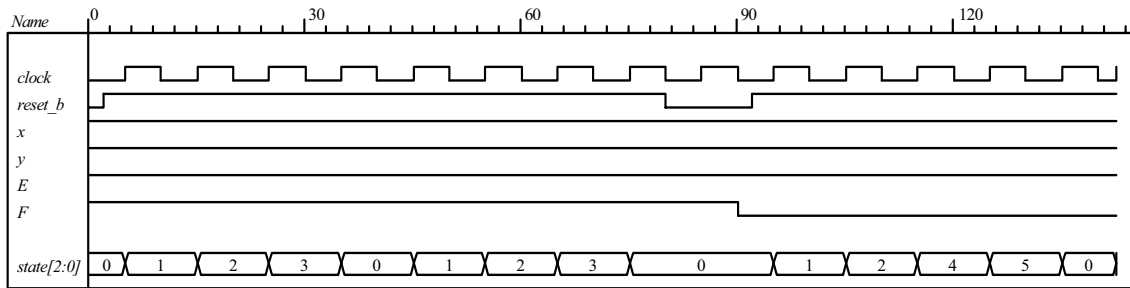

Path: S\_0, S\_1, S\_2, S\_4, S\_6, S\_7

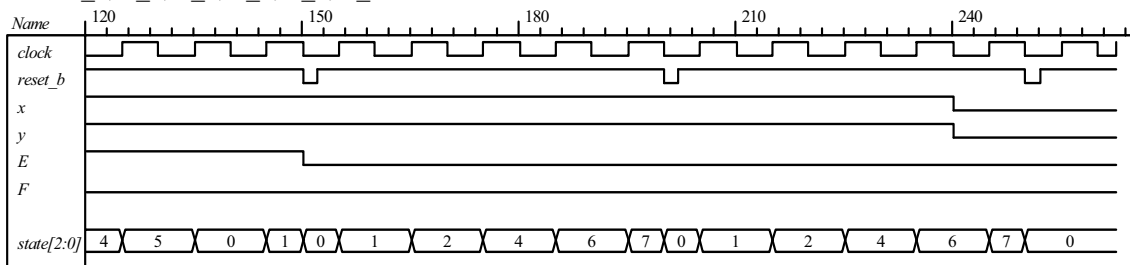

Path: S\_0 and Path , S\_0, S\_2, S\_4, S\_6, S\_7

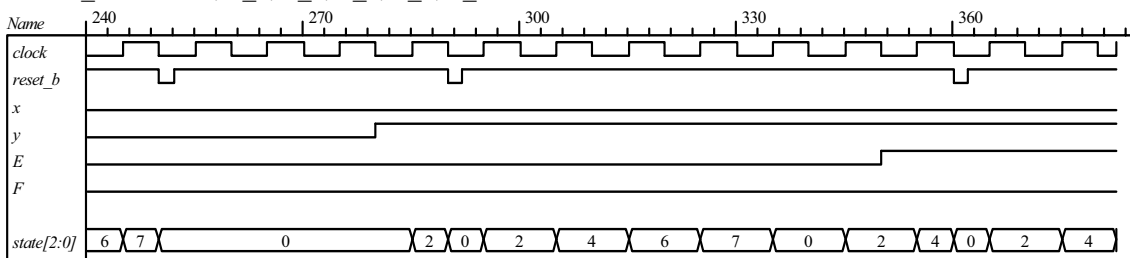

Path: S\_0, S\_2, S\_4, S\_5 and path S\_0, S\_2, S\_3

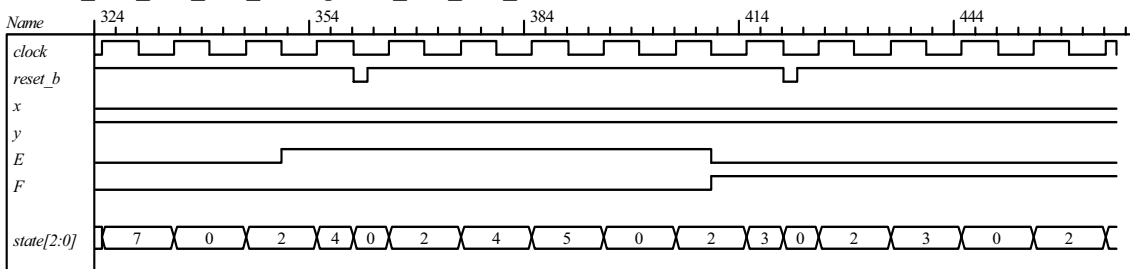

(h)

```

module Controller_8_29h (input x, y, E, F, clock, reset_b);
parameter S_0 = 3'b000, S_1 = 3'b001, S_2 = 3'b010,
           S_3 = 3'b011, S_4 = 3'b100, S_5 = 3'b101, S_6 = 3'b110, S_7 = 3'b111;
reg [2:0] state, next_state;

always @ (posedge clock, negedge reset_b)
if (!reset_b) state <= S_0; else state <= next_state;
    
```

```

always @ (state, x, y, E, F) begin
  case (state)
    S_0:      if (x) next_state = S_1;
              else next_state = y ? S_2: S_0;
    S_1:      next_state = S_2;
    S_2:      if (F) next_state = S_3; else next_state = S_4;
    S_3, S_5, S_7: next_state = S_0;
    S_4:      if (E) next_state = S_5; else next_state = S_6;
    S_6:      next_state = S_7;
    default:  next_state = S_0;
  endcase
end
endmodule

// Test plan: Exercise all paths of the ASM chart

module t_Controller_8_29h ();
  reg x, y, E, F, clock, reset_b;

  Controller_8_29h M0 (x, y, E, F, clock, reset_b);

  initial #500 $finish;
  initial begin clock = 0; forever #5 clock = ~clock; end
  initial begin end
  initial fork
    reset_b = 0; #2 reset_b = 1;
    #20 begin x = 1; y = 1; E = 1; F = 1; end // Path: S_0, S_1, S_2, S_34
    #80 reset_b = 0; #92 reset_b = 1;
    #90 begin x = 1; y = 1; E = 1; F = 0; end
    #150 reset_b = 0;
    #152 reset_b = 1;
    #150 begin x = 1; y = 1; E = 0; F = 0; end // Path: S_0, S_1, S_2, S_4, S_5
    #200 reset_b = 0;
    #202 reset_b = 1;
    #190 begin x = 1; y = 1; E = 0; F = 0; end // Path: S_0, S_1, S_2, S_4, S_6, S_7
    #250 reset_b = 0;
    #252 reset_b = 1;
    #240 begin x = 0; y = 0; E = 0; F = 0; end // Path: S_0
    #290 reset_b = 0;
    #292 reset_b = 1;
    #280 begin x = 0; y = 1; E = 0; F = 0; end // Path: S_0, S_2, S_4, S_6, S_7
    #360 reset_b = 0;
    #362 reset_b = 1;
    #350 begin x = 0; y = 1; E = 1; F = 0; end // Path: S_0, S_2, S_4, S_5
    #420 reset_b = 0;
    #422 reset_b = 1;
    #410 begin x = 0; y = 1; E = 0; F = 1; end // Path: S_0, S_2, S_3
  join
endmodule

```

Note: Simulation results match those for 8.39g.

8.30 (a)  $E = 1$  (b)  $E = 0$

8.31  $A = 0110, B = 0010, C = 0000.$

$A * B = 1100$	$A   B = 0110$	$A \&\& C = 0$
$A + B = 1000$	$A \wedge B = 0100$	$  A = 1$
$A - B = 0100$	$\&A = 0$	$A < B = 0$
$\sim C = 1111$	$\sim C = 1$	$A > B = 1$
$A \& B = 0010$	$A    B = 1$	$A ! B = 1$

8.32

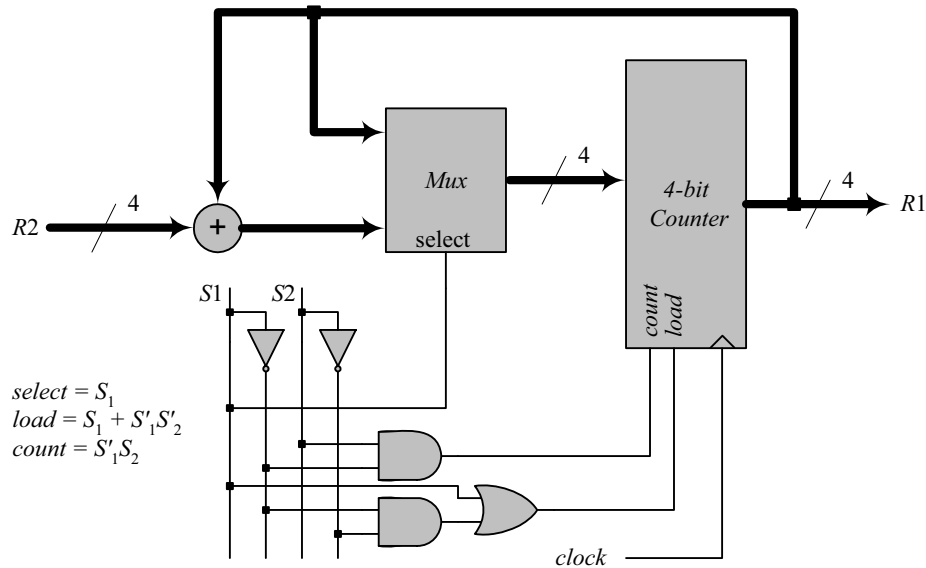

8.33

Assume that the states are encoded one-hot as  $T_0, T_1, T_2, T_3$ . The select lines of the mux are generated as:

$$s_1 = T_2 + T_3$$

$$s_0 = T_1 + T_3$$

The signal to load  $R_4$  can be generated by the host processor or by:

$$load = T_0 + T_1 + T_2 + T_3$$

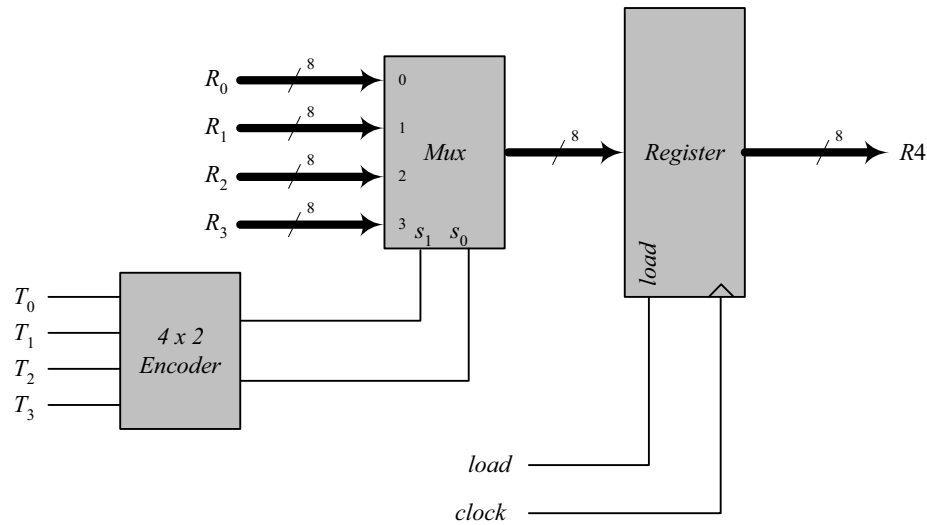

8.34 (a)

```

module Datapath_BEH
#(parameter dp_width = 8, R2_width = 4)
(
    output [R2_width -1: 0] count, output reg E, output Zero, input [dp_width -1: 0] data,
    input Load_regs, Shift_left, Incr_R2, clock, reset_b);
    
```

```
reg [dp_width -1: 0] R1;
reg [R2_width -1: 0] R2;

assign count = R2;
assign Zero = ~(| R1);
always @ (posedge clock) begin
    E <= R1[dp_width -1] & Shift_left;
    if (Load_regs) begin R1 <= data; R2 <= {R2_width{1'b1}}; end
    if (Shift_left) {E, R1} <= {E, R1} << 1;
    if (Incr_R2) R2 <= R2 + 1;
end
endmodule

// Test Plan for Datapath Unit:
// Demonstrate action of Load_regs
//   R1 gets data, R2 gets all ones
// Demonstrate action of Incr_R2
// Demonstrate action of Shift_left and detect E

// Test bench for datapath

module t_Datapath_Unit
#(parameter dp_width = 8, R2_width = 4)
();
    wire [R2_width -1: 0] count;
    wire                  E, Zero;
    reg [dp_width -1: 0] data;
    reg                  Load_regs, Shift_left, Incr_R2, clock, reset_b;

    Datapath_BEH M0 (count, E, Zero, data, Load_regs, Shift_left, Incr_R2, clock, reset_b);

    initial #250 $finish;
    initial begin clock = 0; forever #5 clock = ~clock; end
    initial begin reset_b = 0; #2 reset_b = 1; end
    initial fork
        data = 8'haa;
        Load_regs = 0;
        Incr_R2 = 0;
        Shift_left = 0;
        #10 Load_regs = 1;
        #20 Load_regs = 0;
        #50 Incr_R2 = 1;
        #120 Incr_R2 = 0;
        #90 Shift_left = 1;
        #200 Shift_left = 0;
    join
endmodule
```

Note: The simulation results show tests of the operations of the datapath independent of the control unit, so *count* does not represent the number of ones in the *data*.



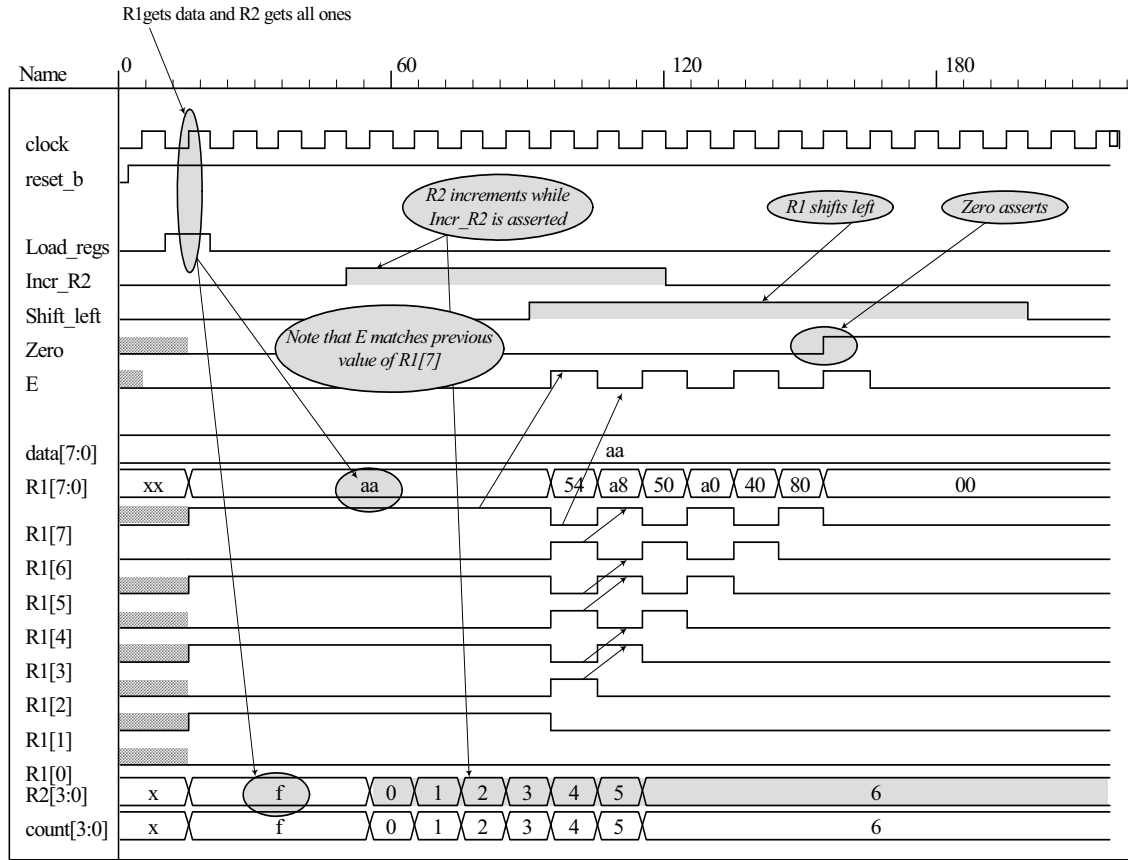

```
(b) // Control Unit
module Controller_BEH (
  output    Ready,
  output reg Load_regs,
  output    Incr_R2, Shift_left,
  input     Start, Zero, E, clock, reset_b
);
parameter S_idle = 0, S_1 = 1, S_2 = 2, S_3 = 3;
reg [1:0] state, next_state;

assign Ready = (state == S_idle);
assign Incr_R2 = (state == S_1);
assign Shift_left = (state == S_2);

always @ (posedge clock, negedge reset_b)
  if (reset_b == 0) state <= S_idle;
  else state <= next_state;

always @ (state, Start, Zero, E) begin
  Load_regs = 0;
  case (state)
    S_idle: if (Start) begin Load_regs = 1; next_state = S_1; end
           else next_state = S_idle;
    S_1:   if (Zero) next_state = S_idle; else next_state = S_2;

    S_2:   next_state = S_3;
    S_3:   if (E) next_state = S_1; else next_state = S_2;
  endcase
end
```

**endmodule**

```
// Test plan for Control Unit
// Verify that state enters S_idle with reset_b asserted.
// With reset_b de-asserted, verify that state enters S_1 and asserts Load_Regs when
// Start is asserted.
// Verify that Incr_R2 is asserted in S_1.
// Verify that state returns to S_idle from S_1 if Zero is asserted.
// Verify that state goes to S_2 if Zero is not asserted.
// Verify that Shift_left is asserted in S_2.
// Verify that state goes to S_3 from S_2 unconditionally.
// Verify that state returns to S_2 from S_3 if E is not asserted.
// Verify that state goes to S_1 from S_3 if E is asserted.
```

// Test bench for Control Unit

```
module t_Control_Unit ();
wire Ready, Load_regs, Incr_R2, Shift_left;
reg Start, Zero, E, clock, reset_b;

Controller_BEH M0 (Ready, Load_regs, Incr_R2, Shift_left, Start, Zero, E, clock, reset_b);

initial #250 $finish;
initial begin clock = 0; forever #5 clock = ~clock; end
initial begin reset_b = 0; #2 reset_b = 1; end
initial fork
  Zero = 1;
  E = 0;
  Start = 0;
  #20 Start = 1; // Cycle from S_idle to S_1
  #80 Start = 0;
  #70 Zero = 0; // S_idle to S_1 to S_2 to S_3 and cycle to S_2.
  #130 E = 1; // Cycle to S_3 to S_1 to S_2 to S_3
  #150 Zero = 1; // Return to S_idle
join
endmodule
```

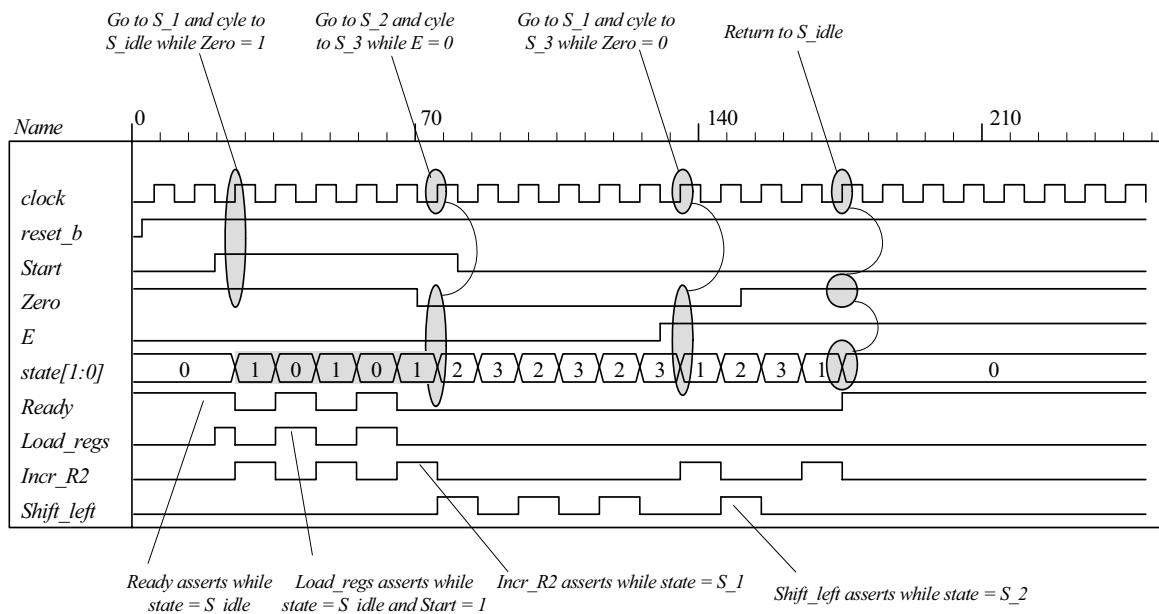

```
(c)
// Integrated system
module Count_Ones_BEH_BEH
# (parameter dp_width = 8, R2_width = 4)
(
  output [R2_width -1: 0] count,
  input [dp_width -1: 0] data,
  input Start, clock, reset_b
);
wire Load_regs, Incr_R2, Shift_left, Zero, E;
  Controller_BEH M0 (Ready, Load_regs, Incr_R2, Shift_left, Start, Zero, E, clock, reset_b);
  Datapath_BEH M1 (count, E, Zero, data, Load_regs, Shift_left, Incr_R2, clock, reset_b);
endmodule

// Test plan for integrated system
// Test for data values of 8'haa, 8'h00, 8'hff.

// Test bench for integrated system

module t_count_Ones_BEH_BEH ();
  parameter dp_width = 8, R2_width = 4;
  wire [R2_width -1: 0] count;
  reg [dp_width -1: 0] data;
  reg Start, clock, reset_b;

  Count_Ones_BEH_BEH M0 (count, data, Start, clock, reset_b);
  initial #700 $finish;
  initial begin clock = 0; forever #5 clock = ~clock; end
  initial begin reset_b = 0; #2 reset_b = 1; end
  initial fork
    data = 8'haa; // Expect count = 4
    Start = 0;
    #20 Start = 1;
    #30 Start = 0;
    #40 data = 8'b00; // Expect count = 0
    #250 Start = 1;
    #260 Start = 0;
    #280 data = 8'hff;
    #280 Start = 1;
    #290 Start = 0;
  join
endmodule
```

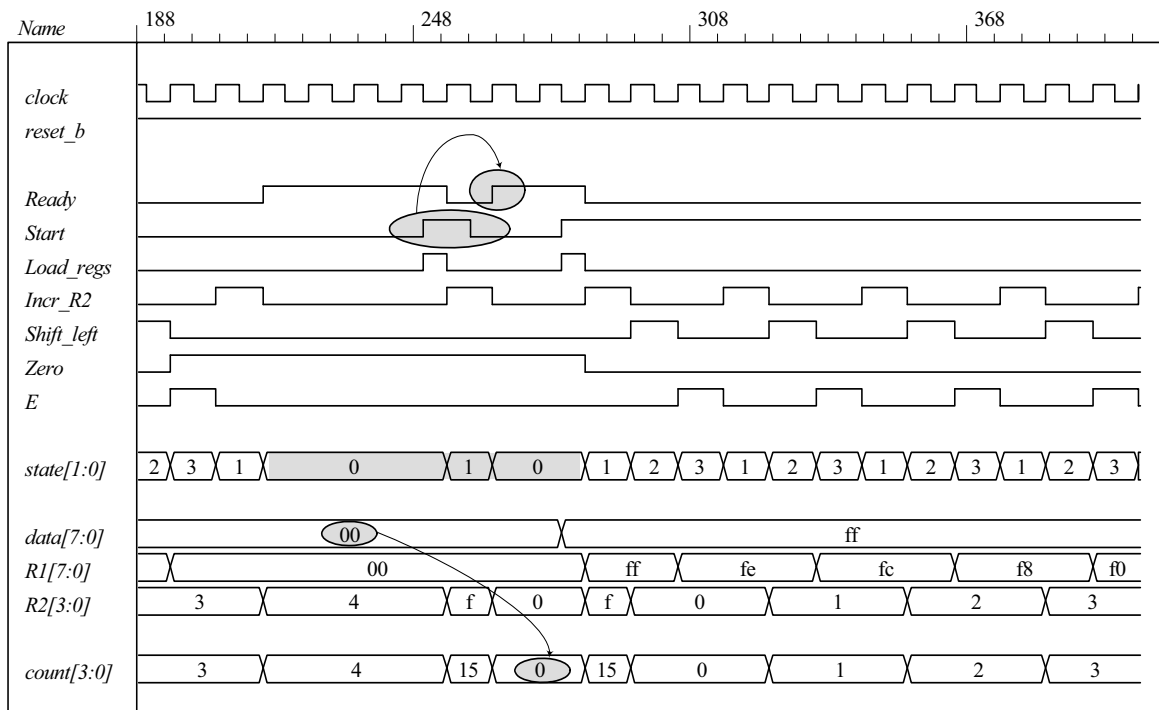
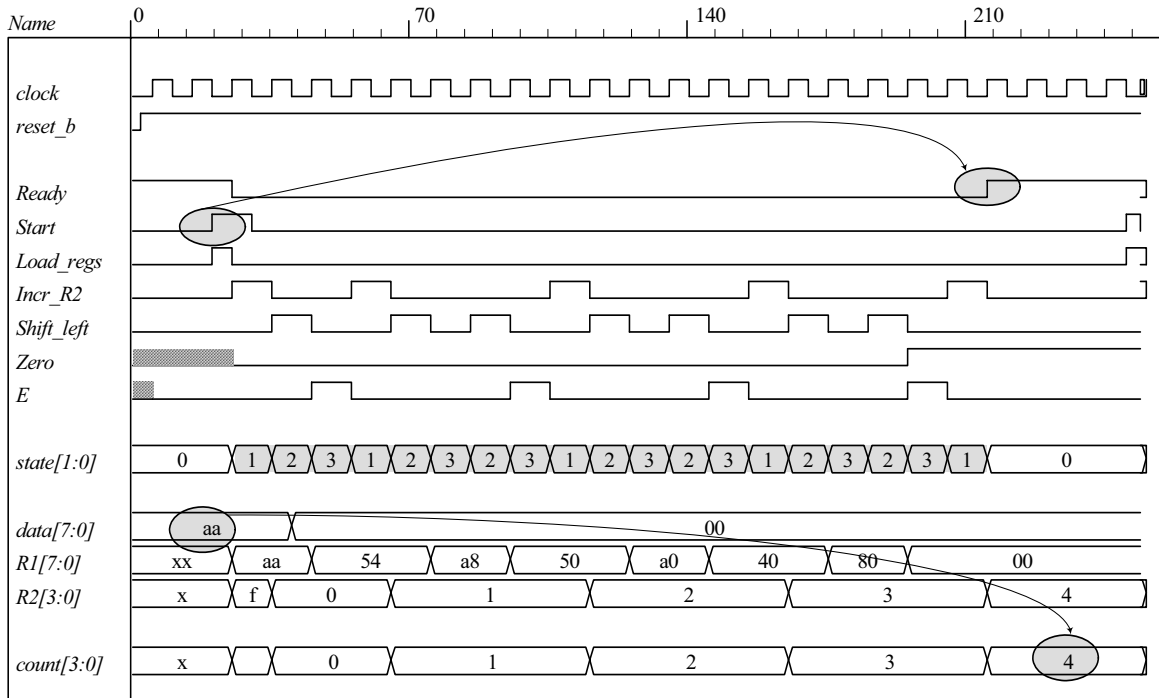

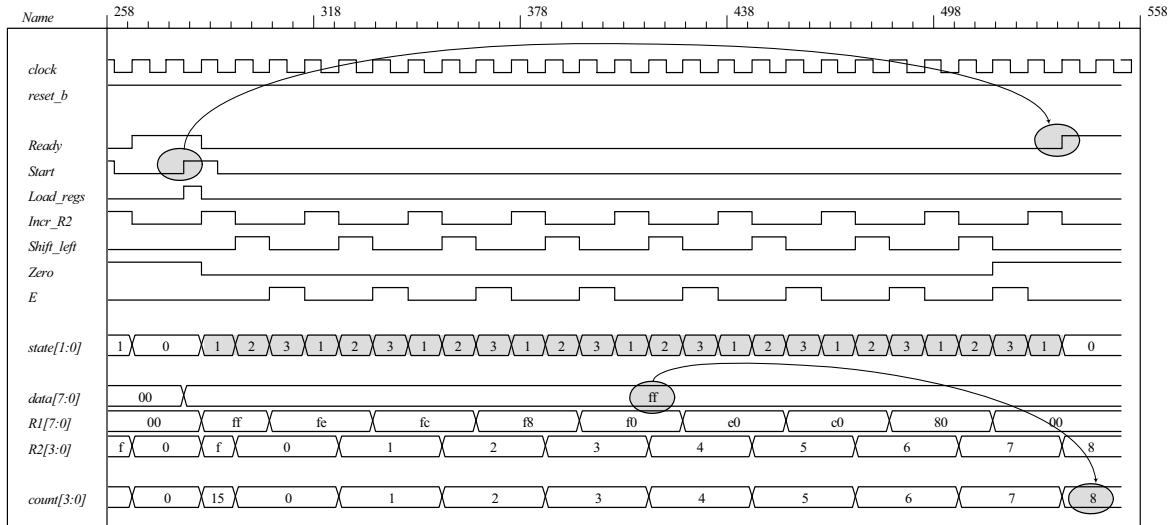

(d)

// One-Hot Control unit

```

module Controller_BEH_1Hot
(
  output    Ready,
  output reg Load_regs,
  output    Incr_R2, Shift_left,
  input     Start, Zero, E, clock, reset_b
);
  parameter S_idle = 4'b0001, S_1 = 4'b0010, S_2 = 4'b0100, S_3 = 4'b1000;
  reg [3:0] state, next_state;

  assign Ready = (state == S_idle);
  assign Incr_R2 = (state == S_1);
  assign Shift_left = (state == S_2);

  always @ (posedge clock, negedge reset_b)
    if (reset_b == 0) state <= S_idle;
    else state <= next_state;

  always @ (state, Start, Zero, E) begin
    Load_regs = 0;
    case (state)
      S_idle: if (Start) begin Load_regs = 1; next_state = S_1; end
              else next_state = S_idle;
      S_1:   if (Zero) next_state = S_idle; else next_state = S_2;

      S_2:   next_state = S_3;
      S_3:   if (E) next_state = S_1; else next_state = S_2;
    endcase
  end
endmodule

```

Note: Test plan, test bench and simulation results are same as (b), but with states numbered with one-hot codes.

(e)

// Integrated system with one-hot controller

```

module Count_Ones_BEH_1Hot
# (parameter dp_width = 8, R2_width = 4)
(
  output [R2_width -1: 0]    count,
  input [dp_width -1: 0]    data,
  input                      Start, clock, reset_b
);
  wire Load_regs, Incr_R2, Shift_left, Zero, E;
  Controller_BEH_1Hot M0 (Ready, Load_regs, Incr_R2, Shift_left, Start, Zero, E, clock, reset_b);
  Datapath_BEH M1 (count, E, Zero, data, Load_regs, Shift_left, Incr_R2, clock, reset_b);
endmodule

```

Note: Test plan, test bench and simulation results are same as (c), but with states numbered with one-hot codes.

**8.35** Note: Signal *Start* is initialized to 0 when the simulation begins. Otherwise, the state of the structural model will become X at the first clock after the reset condition is deasserted, with *Start* and *Load\_Regs* having unknown values. In this condition the structural model cannot operate correctly.

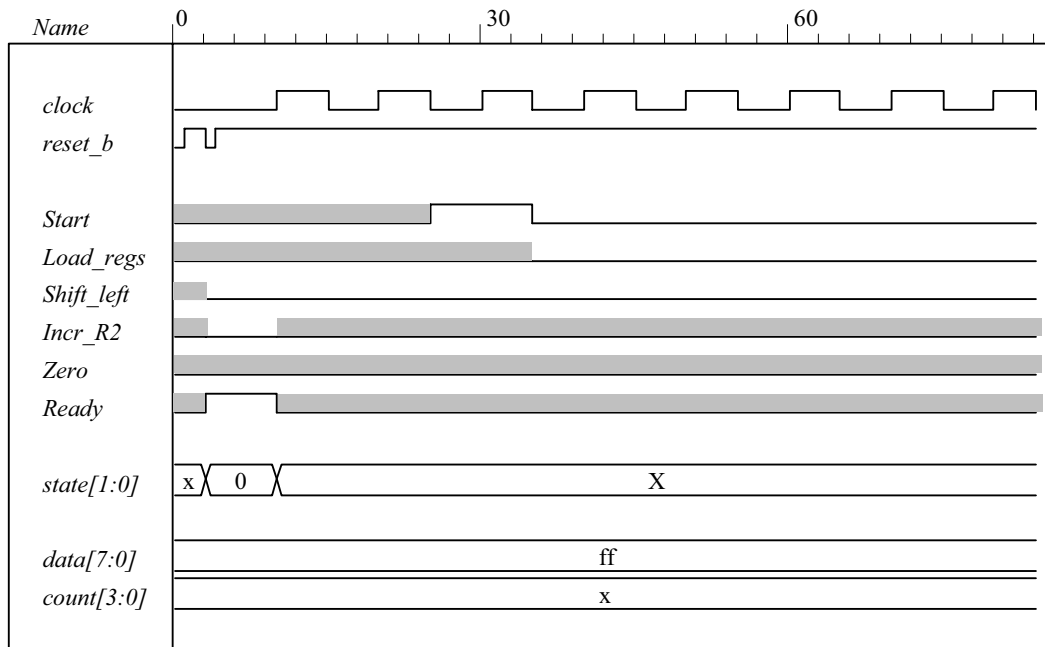

```

module Count_Ones_STR_STR (count, Ready, data, Start, clock, reset_b);
// Mux – decoder implementation of control logic
// controller is structural
// datapath is structural

  parameter R1_size = 8, R2_size = 4;
  output [R2_size -1: 0]    count;
  output                      Ready;
  input [R1_size -1: 0]    data;
  input                      Start, clock, reset_b;
  wire                      Load_regs, Shift_left, Incr_R2, Zero, E;

  Controller_STR M0 (Ready, Load_regs, Shift_left, Incr_R2, Start, E, Zero, clock, reset_b);
  Datapath_STR M1 (count, E, Zero, data, Load_regs, Shift_left, Incr_R2, clock);

endmodule

```

```

module Controller_STR (Ready, Load_regs, Shift_left, Incr_R2, Start, E, Zero, clock, reset_b);
  output      Ready;
  output      Load_regs, Shift_left, Incr_R2;
  input       Start;
  input       E, Zero;
  input       clock, reset_b;
  supply0    GND;
  supply1    PWR;
  parameter  S0 = 2'b00, S1 = 2'b01, S2 = 2'b10, S3 = 2'b11; // Binary code
  wire       Load_regs, Shift_left, Incr_R2;
  wire       G0, G0_b, D_in0, D_in1, G1, G1_b;
  wire       Zero_b = ~Zero;

  wire       E_b = ~E;
  wire [1:0] select = {G1, G0};
  wire [0:3] Decoder_out;

  assign     Ready = ~Decoder_out[0];
  assign     Incr_R2 = ~Decoder_out[1];
  assign     Shift_left = ~Decoder_out[2];
  and        (Load_regs, Ready, Start);
  mux_4x1_beh Mux_1 (D_in1, GND, Zero_b, PWR, E_b, select);
  mux_4x1_beh Mux_0 (D_in0, Start, GND, PWR, E, select);
  D_flip_flop_AR_b M1 (G1, G1_b, D_in1, clock, reset_b);
  D_flip_flop_AR_b M0 (G0, G0_b, D_in0, clock, reset_b);
  decoder_2x4_df M2 (Decoder_out, G1, G0, GND);

endmodule

```

```

module Datapath_STR (count, E, Zero, data, Load_regs, Shift_left, Incr_R2, clock);
  parameter  R1_size = 8, R2_size = 4;
  output [R2_size -1: 0] count;
  output     E, Zero;
  input [R1_size -1: 0] data;
  input     Load_regs, Shift_left, Incr_R2, clock;
  wire [R1_size -1: 0] R1;
  supply0  Gnd;
  supply1  Pwr;
  assign   Zero = (R1 == 0);

  Shift_Reg      M1 (R1, data, Gnd, Shift_left, Load_regs, clock, Pwr);
  Counter        M2 (count, Load_regs, Incr_R2, clock, Pwr);
  D_flip_flop_AR M3 (E, w1, clock, Pwr);
  and          ( w1, R1[R1_size -1], Shift_left);

endmodule

```

```

module Shift_Reg (R1, data, SI_0, Shift_left, Load_regs, clock, reset_b);
  parameter  R1_size = 8;
  output [R1_size -1: 0] R1;
  input [R1_size -1: 0] data;
  input     SI_0, Shift_left, Load_regs;
  input     clock, reset_b;
  reg [R1_size -1: 0] R1;

  always @ (posedge clock, negedge reset_b)
  if (reset_b == 0) R1 <= 0;
  else begin
    if (Load_regs) R1 <= data; else
      if (Shift_left) R1 <= {R1[R1_size -2:0], SI_0}; end
endmodule

```

```
module Counter (R2, Load_regs, Incr_R2, clock, reset_b);  
  parameter      R2_size = 4;  
  output [R2_size -1: 0] R2;  
  input          Load_regs, Incr_R2;  
  input          clock, reset_b;  
  reg [R2_size -1: 0] R2;
```

```
  always @ (posedge clock, negedge reset_b)  
    if (reset_b == 0) R2 <= 0;  
    else if (Load_regs) R2 <= {R2_size {1'b1}}; // Fill with 1  
    else if (Incr_R2 == 1) R2 <= R2 + 1;  
endmodule
```

```
module D_flip_flop_AR (Q, D, CLK, RST);  
  output Q;  
  input D, CLK, RST;  
  reg Q;
```

```
  always @ (posedge CLK, negedge RST)  
    if (RST == 0) Q <= 1'b0;  
    else Q <= D;  
endmodule
```

```
module D_flip_flop_AR_b (Q, Q_b, D, CLK, RST);  
  output Q, Q_b;  
  input D, CLK, RST;  
  reg Q;  
  assign Q_b = ~Q;  
  always @ (posedge CLK, negedge RST)  
    if (RST == 0) Q <= 1'b0;  
    else Q <= D;  
endmodule
```

```
// Behavioral description of 4-to-1 line multiplexer  
// Verilog 2005 port syntax
```

```
module mux_4x1_beh  
( output reg m_out,  
  input in_0, in_1, in_2, in_3,  
  input [1: 0] select  
);
```

```
  always @ (in_0, in_1, in_2, in_3, select) // Verilog 2005 syntax  
    case (select)  
      2'b00: m_out = in_0;  
      2'b01: m_out = in_1;  
      2'b10: m_out = in_2;  
      2'b11: m_out = in_3;  
    endcase  
endmodule
```

```
// Dataflow description of 2-to-4-line decoder  
// See Fig. 4.19. Note: The figure uses symbol E, but the  
// Verilog model uses enable to clearly indicate functionality.
```

```
module decoder_2x4_df (D, A, B, enable);  
  output [0: 3] D;  
  
  input A, B;  
  input enable;
```



```
assign D[0] = ~(~A & ~B & ~enable),
        D[1] = ~(~A & B & ~enable),
        D[2] = ~(A & ~B & ~enable),
        D[3] = ~(A & B & ~enable);
endmodule

module t_Count_Ones;
parameter R1_size = 8, R2_size = 4;
wire [R2_size -1: 0] R2;

wire [R2_size -1: 0] count;
wire Ready;
reg [R1_size -1: 0] data;
reg Start, clock, reset_b;
wire [1: 0] state; // Use only for debug
assign state = {M0.M0.G1, M0.M0.G0};

Count_Ones_STR_STR M0 (count, Ready, data, Start, clock, reset_b);

initial #4000 $finish;
initial begin clock = 0; #5 forever #5 clock = ~clock; end
initial fork
    Start = 0;

    #1 reset_b = 1;
    #3 reset_b = 0;
    #4 reset_b = 1;
    data = 8'Hff;
    # 25 Start = 1;
    # 35 Start = 0;
    #310 data = 8'h0f;
    #310 Start = 1;
    #320 Start = 0;
    #610 data = 8'hf0;
    #610 Start = 1;
    #620 Start = 0;
    #910 data = 8'h00;
    #910 Start = 1;
    #920 Start = 0;
    #1210 data = 8'haa;
    #1210 Start = 1;
    #1220 Start = 0;
    #1510 data = 8'h0a;
    #1510 Start = 1;
    #1520 Start = 0;
    #1810 data = 8'ha0;
    #1810 Start = 1;
    #1820 Start = 0;
    #2110 data = 8'h55;
    #2110 Start = 1;
    #2120 Start = 0;
    #2410 data = 8'h05;
    #2410 Start = 1;
    #2420 Start = 0;
    #2710 data = 8'h50;
    #2710 Start = 1;
    #2720 Start = 0;
    #3010 data = 8'ha5;
    #3010 Start = 1;
    #3020 Start = 0;
    #3310 data = 8'h5a;
    #3310 Start = 1;

```

```
#3320 Start = 0;
join
endmodule
```

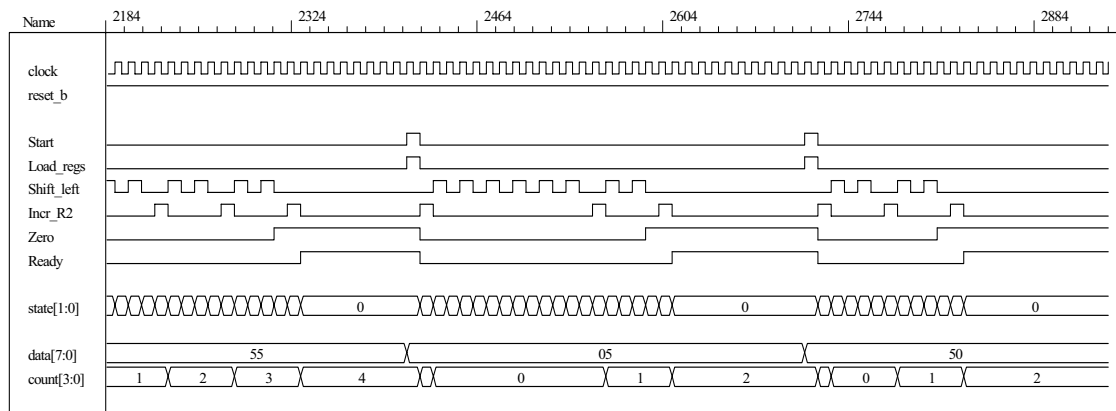

**8.36** Note: See Prob. 8.35 for a behavioral model of the datapath unit, Prob. 8.36d for a one-hot control unit.

- (a)  $T_0, T_1, T_2, T_3$  be asserted when the state is in  $S\_idle, S\_1, S\_2,$  and  $S\_3,$  respectively. Let  $D_0, D_1, D_2,$  and  $D_3$  denote the inputs to the one-hot flip-flops.

$$D_0 = T_0 Start' + T_1 Zero$$

$$D_1 = T_0 Start + T_3 E$$

$$D_2 = T_1 Zero' + T_3 E'$$

$$D_3 = T_2$$

- (b) Gate-level one-hot controller

```
module Controller_Gates_1Hot
(
  output Ready,
  output Load_regs, Incr_R2, Shift_left,
  input Start, Zero, E, clock, reset_b
);
  wire w1, w2, w3, w4, w5, w6;
  wire T0, T1, T2, T3;
  wire set;
  assign Ready = T0;
  assign Incr_R2 = T1;
  assign Shift_left = T2;
  and (Load_regs, T0, Start);
  not (set, reset_b);
  DFF_S M0 (T0, D0, clock, set); // Note: reset action must initialize S_idle = 4'b0001
  DFF M1 (T1, D1, clock, reset_b);
  DFF M2 (T2, D2, clock, reset_b);
  DFF M3 (T3, D3, clock, reset_b);

  not (Start_b, Start);
  and (w1, T0, Start_b);
  and (w2, T1, Zero);
  or (D0, w1, w2);
```

```
and (w3, T0, Start);
and (w4, T3, E);
or (D1, w3, w4);

not (Zero_b, Zero);
not (E_b, E);
and (w5, T1, Zero_b);
and (w6, T3, E_b);
or (D2, w5, w6);

buf (D3, T2);
endmodule

module DFF (output reg Q, input D, clock, reset_b);
always @ (posedge clock, negedge reset_b)
  if (reset_b == 0) Q <= 0;
  else Q <= D;
endmodule

module DFF_S (output reg Q, input D, clock, set);
always @ (posedge clock, posedge set)
  if (set == 1) Q <= 1;
  else Q <= D;
endmodule
```

(c)

```
// Test plan for Control Unit
// Verify that state enters S_idle with reset_b asserted.
// With reset_b de-asserted, verify that state enters S_1 and asserts Load_Regs when
// Start is asserted.
// Verify that Incr_R2 is asserted in S_1.
// Verify that state returns to S_idle from S_1 if Zero is asserted.
// Verify that state goes to S_2 if Zero is not asserted.
// Verify that Shift_left is asserted in S_2.
// Verify that state goes to S_3 from S_2 unconditionally.
// Verify that state returns to S_2 from S_3 if E is not asserted.
// Verify that state goes to S_1 from S_3 if E is asserted.

// Test bench for One-Hot Control Unit

module t_Control_Unit ();
wire Ready, Load_regs, Incr_R2, Shift_left;
reg Start, Zero, E, clock, reset_b;
wire [3: 0] state = {M0.T3, M0.T2, M0.T1, M0.T0}; // Observe one-hot state bits
Controller_Gates_1Hot M0 (Ready, Load_regs, Incr_R2, Shift_left, Start, Zero, E, clock, reset_b);

initial #250 $finish;
initial begin clock = 0; forever #5 clock = ~clock; end
initial begin reset_b = 0; #2 reset_b = 1; end
initial fork
  Zero = 1;
  E = 0;
  Start = 0;
  #20 Start = 1; // Cycle from S_idle to S_1
  #80 Start = 0;
  #70 Zero = 0; // S_idle to S_1 to S_2 to S_3 and cycle to S_2.
  #130 E = 1; // Cycle to S_3 to S_1 to S_2 to S_3
  #150 Zero = 1; // Return to S_idle
join
endmodule
```

Note: simulation results match those for Prob. 8.34(d). See Prob. 8.34(c) for annotations.

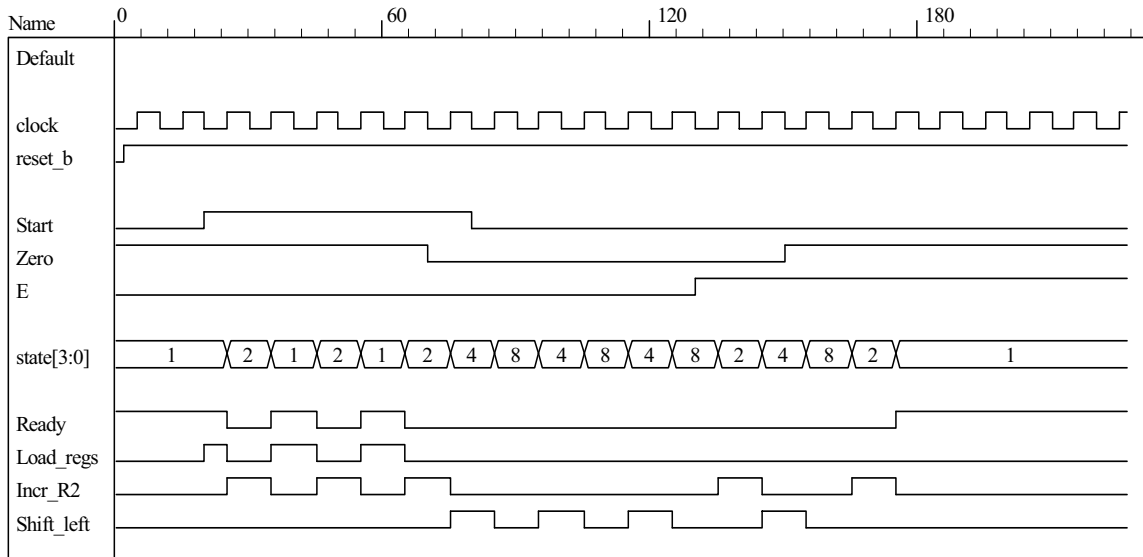

(d) Datapath unit detail:

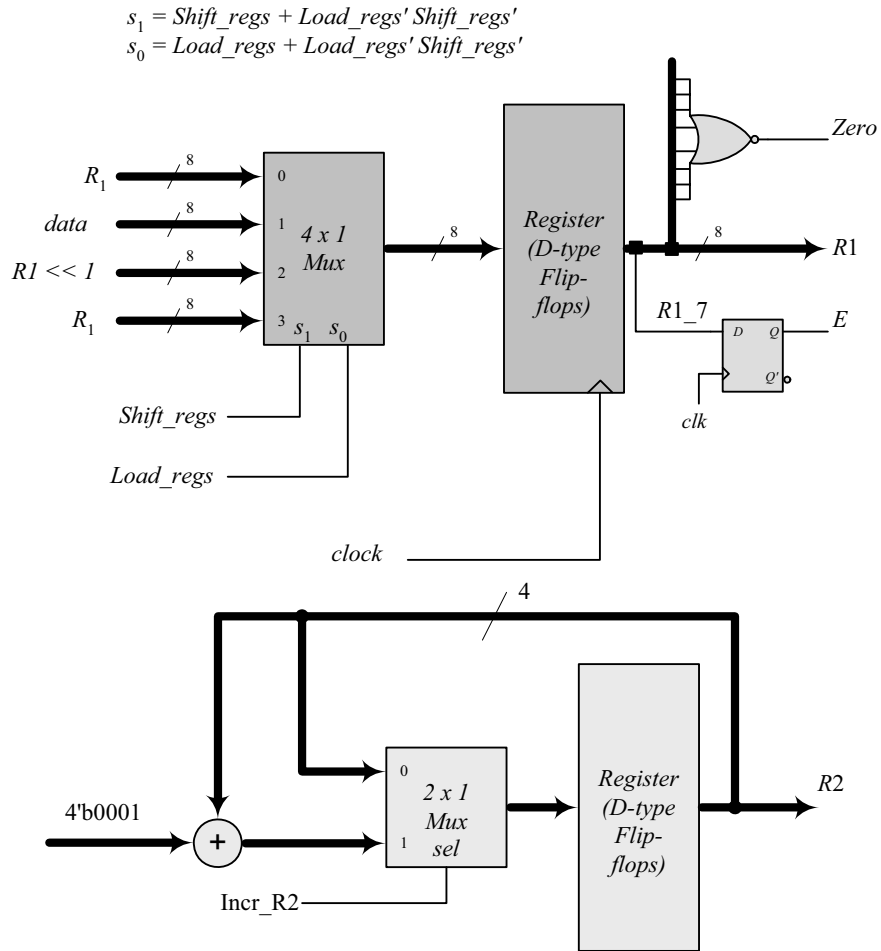

```
// Datapath unit – structural model
module Datapath_STR
#(parameter dp_width = 8, R2_width = 4)
(
  output [R2_width -1: 0] count, output E, output Zero, input [dp_width -1: 0] data,
  input Load_regs, Shift_left, Incr_R2, clock, reset_b);
  supply1 pwr;
  supply0 gnd;
  wire [dp_width -1: 0] R1_Dbus, R1;
  wire [R2_width -1: 0] R2_Dbus;
  wire DR1_0, DR1_1, DR1_2, DR1_3, DR1_4, DR1_5, DR1_6, DR1_7;
  wire R1_0, R1_1, R1_2, R1_3, R1_4, R1_5, R1_6, R1_7;
  wire R2_0, R2_1, R2_2, R2_3;
  wire [R2_width -1: 0] R2 = {R2_3, R2_2, R2_1, R2_0};
  assign count = {R2_3, R2_2, R2_1, R2_0};
  assign R1 = { R1_7, R1_6, R1_5, R1_4, R1_3, R1_2, R1_1, R1_0};
  assign DR1_0 = R1_Dbus[0];
  assign DR1_1 = R1_Dbus[1];
  assign DR1_2 = R1_Dbus[2];
  assign DR1_3 = R1_Dbus[3];
  assign DR1_4 = R1_Dbus[4];
  assign DR1_5 = R1_Dbus[5];
  assign DR1_6 = R1_Dbus[6];
  assign DR1_7 = R1_Dbus[7];

  nor (Zero, R1_0, R1_1, R1_2, R1_3, R1_4, R1_5, R1_6, R1_7);
  DFF D_E (E, R1_7, clock, pwr);

  DFF DF_0 (R1_0, DR1_0, clock, pwr); // Disable reset
  DFF DF_1 (R1_1, DR1_1, clock, pwr);
  DFF DF_2 (R1_2, DR1_2, clock, pwr);
  DFF DF_3 (R1_3, DR1_3, clock, pwr);
  DFF DF_4 (R1_4, DR1_4, clock, pwr);
  DFF DF_5 (R1_5, DR1_5, clock, pwr);
  DFF DF_6 (R1_6, DR1_6, clock, pwr);
  DFF DF_7 (R1_7, DR1_7, clock, pwr);

  DFF_S DR_0 (R2_0, DR2_0, clock, Load_regs); // Load_regs (set) drives R2 to all ones
  DFF_S DR_1 (R2_1, DR2_1, clock, Load_regs);
  DFF_S DR_2 (R2_2, DR2_2, clock, Load_regs);
  DFF_S DR_3 (R2_3, DR2_3, clock, Load_regs);

  assign DR2_0 = R2_Dbus[0];
  assign DR2_1 = R2_Dbus[1];
  assign DR2_2 = R2_Dbus[2];
  assign DR2_3 = R2_Dbus[3];

  wire [1: 0] sel = {Shift_left, Load_regs};
  wire [dp_width -1: 0] R1_shifted = {R1_6, R1_5, R1_4, R1_3, R1_2, R1_1, R1_0, 1'b0};
  wire [R2_width -1: 0] sum = R2 + 4'b0001;

  Mux8_4_x_1 M0 (R1_Dbus, R1, data, R1_shifted, R1, sel);
  Mux4_2_x_1 M1 (R2_Dbus, R2, sum, Incr_R2);
endmodule
```

```

module Mux8_4_x_1 #(parameter dp_width = 8) (output reg [dp_width -1: 0] mux_out,
input [dp_width -1: 0] in0, in1, in2, in3, input [1: 0] sel);
always @ (in0, in1, in2, in3, sel)
    case (sel)
        2'b00: mux_out = in0;
        2'b01: mux_out = in1;
        2'b10: mux_out = in2;
        2'b11: mux_out = in3;
    endcase
endmodule

module Mux4_2_x_1 #(parameter dp_width = 4) (output [dp_width -1: 0] mux_out,
input [dp_width -1: 0] in0, in1, input sel);
assign mux_out = sel ? in1: in0;
endmodule

// Test Plan for Datapath Unit:
// Demonstrate action of Load_regs
// R1 gets data, R2 gets all ones
// Demonstrate action of Incr_R2
// Demonstrate action of Shift_left and detect E

// Test bench for datapath
module t_Datapath_Unit
#(parameter dp_width = 8, R2_width = 4)
(
    wire [R2_width -1: 0] count;
    wire E, Zero;
    reg [dp_width -1: 0] data;
    reg Load_regs, Shift_left, Incr_R2, clock, reset_b;
    Datapath_STR M0 (count, E, Zero, data, Load_regs, Shift_left, Incr_R2, clock, reset_b);

    initial #250 $finish;
    initial begin clock = 0; forever #5 clock = ~clock; end
    initial begin reset_b = 0; #2 reset_b = 1; end
    initial fork
        data = 8'haa;
        Load_regs = 0;
        Incr_R2 = 0;
        Shift_left = 0;
        #10 Load_regs = 1;
        #20 Load_regs = 0;
        #50 Incr_R2 = 1;
        #120 Incr_R2 = 0;
        #90 Shift_left = 1;
        #200 Shift_left = 0;
    join
endmodule

// Integrated system
module Count_Ones_Gates_1_Hot_STR
#(parameter dp_width = 8, R2_width = 4)
(
    output [R2_width -1: 0] count,
    input [dp_width -1: 0] data,
    input Start, clock, reset_b
);
    wire Load_regs, Incr_R2, Shift_left, Zero, E;
    Controller_Gates_1Hot M0 (Ready, Load_regs, Incr_R2, Shift_left, Start, Zero, E, clock, reset_b);
    Datapath_STR M1 (count, E, Zero, data, Load_regs, Shift_left, Incr_R2, clock, reset_b);
endmodule

```

```
// Test plan for integrated system
// Test for data values of 8'haa, 8'h00, 8'hff.

// Test bench for integrated system

module t_count_Ones_Gates_1_Hot_STR ();
parameter dp_width = 8, R2_width = 4;
wire [R2_width -1: 0] count;
reg [dp_width -1: 0] data;
reg Start, clock, reset_b;
wire [3: 0] state = {M0.M0.T3, M0.M0.T2, M0.M0.T1, M0.M0.T0};

Count_Ones_Gates_1_Hot_STR M0 (count, data, Start, clock, reset_b);
initial #700 $finish;
initial begin clock = 0; forever #5 clock = ~clock; end
initial begin reset_b = 0; #2 reset_b = 1; end
initial fork
    data = 8'haa;    // Expect count = 4
    Start = 0;
    #20 Start = 1;
    #30 Start = 0;
    #40 data = 8'b00;    // Expect count = 0
    #250 Start = 1;
    #260 Start = 0;
    #280 data = 8'hff;
    #280 Start = 1;
    #290 Start = 0;
join
endmodule
```

Note: The simulation results show tests of the operations of the datapath independent of the control unit, so count does not represent the number of ones in the data.

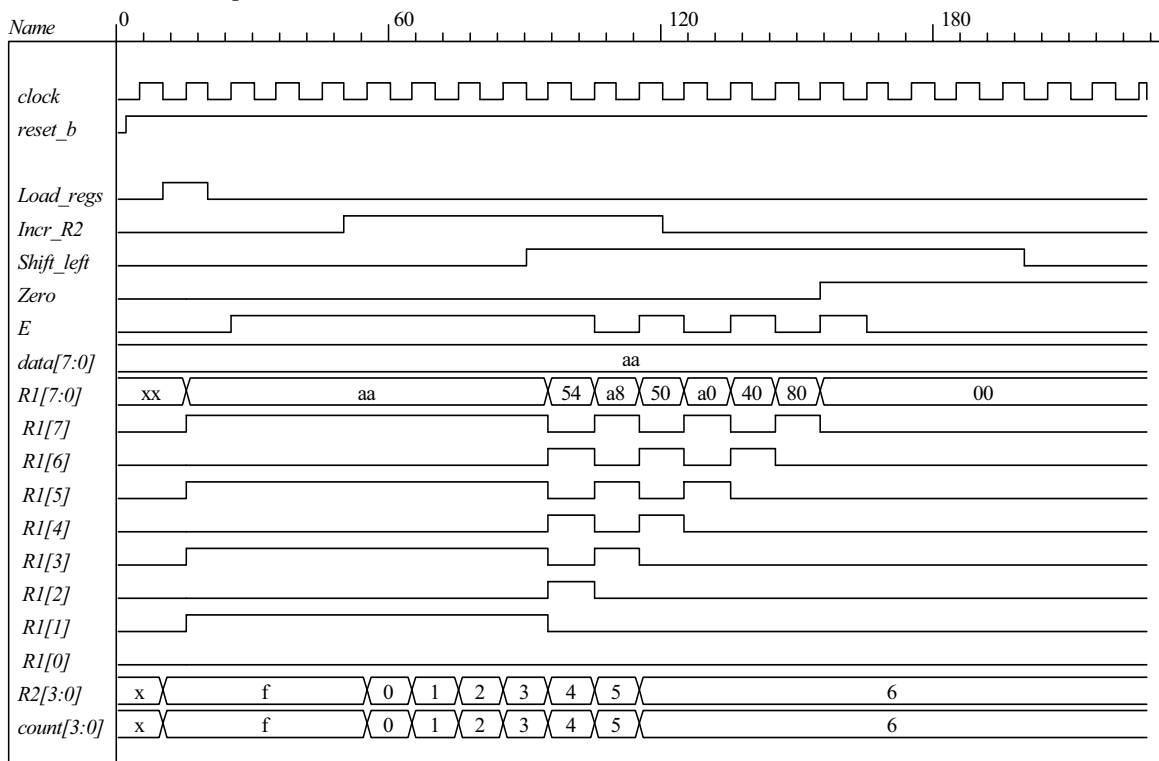

Simulation results for the integrated system match those shown in Prob. 8.34(e). See those results for additional annotation.

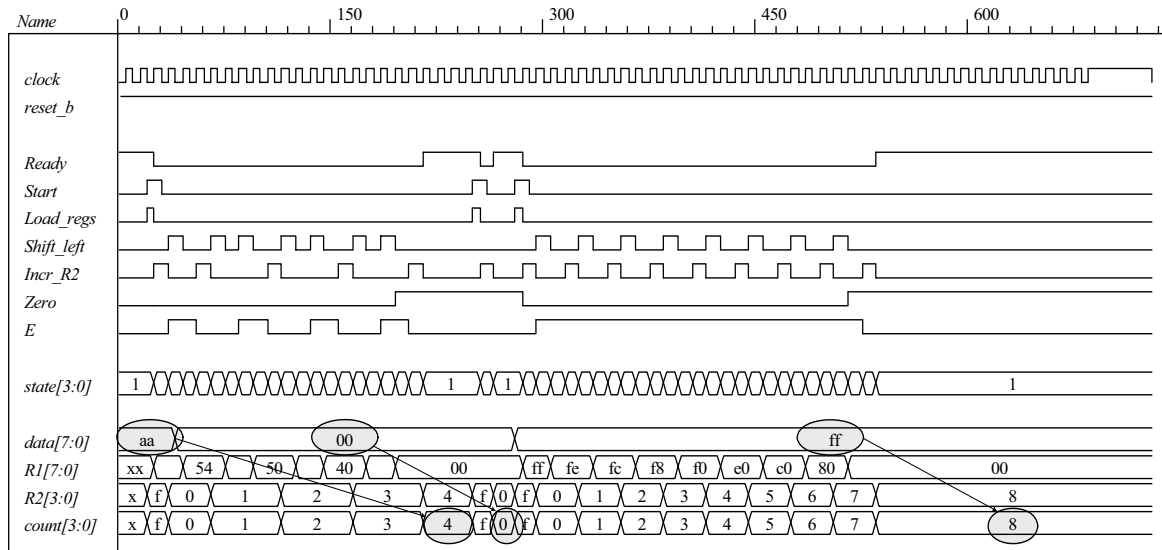

8.37 (a) ASMD chart:

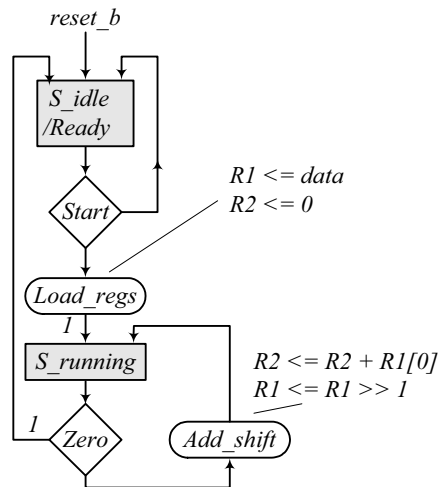

(b) RTL model:

```

module Datapath_Unit_2_Beh #(parameter dp_width = 8, R2_width = 4)
(
    output [R2_width - 1: 0] count,
    output Zero,
    input [dp_width - 1: 0] data,
    input Load_regs, Add_shift, clock, reset_b
);
    reg [dp_width - 1: 0] R1;
    reg [R2_width - 1: 0] R2;
    assign count = R2;
    
```



```
assign Zero = ~|R1;
always @ (posedge clock, negedge reset_b)
begin
  if (reset_b == 0) begin R1 <= 0; R2 <= 0; end else begin
    if (Load_regs) begin R1 <= data; R2 <= 0; end
    if (Add_shift) begin R1 <= R1 >> 1; R2 <= R2 + R1[0]; end // concurrent operations
  end
end
endmodule
```

```
// Test plan for datapath unit
// Verify active-low reset action
// Test for action of Add_shift
// Test for action of Load_regs
```

```
module t_Datapath_Unit_2_Beh();
parameter R1_size = 8, R2_size = 4;
wire [R2_size-1: 0] count;
wire Zero;
reg [R1_size-1: 0] data;
reg Load_regs, Add_shift, clock, reset_b;
```

```
Datapath_Unit_2_Beh M0 (count, Zero, data, Load_regs, Add_shift, clock, reset_b);
```

```
initial #1000 $finish;
initial begin clock = 0; forever #5 clock = ~clock; end
initial fork
  #1 reset_b = 1;
  #3 reset_b = 0;
  #4 reset_b = 1;
join
initial fork
  data = 8'haa;
  Load_regs = 0;
  Add_shift = 0;
  #10 Load_regs = 1;
  #20 Load_regs = 0;
  #50 Add_shift = 1;
  #150 Add_shift = 0;
join
endmodule
```

Note that the operations of the datapath unit are tested independent of the controller, so the actions of *Load\_regs* and *add\_shift* and the value of *count* do not correspond to *data*.

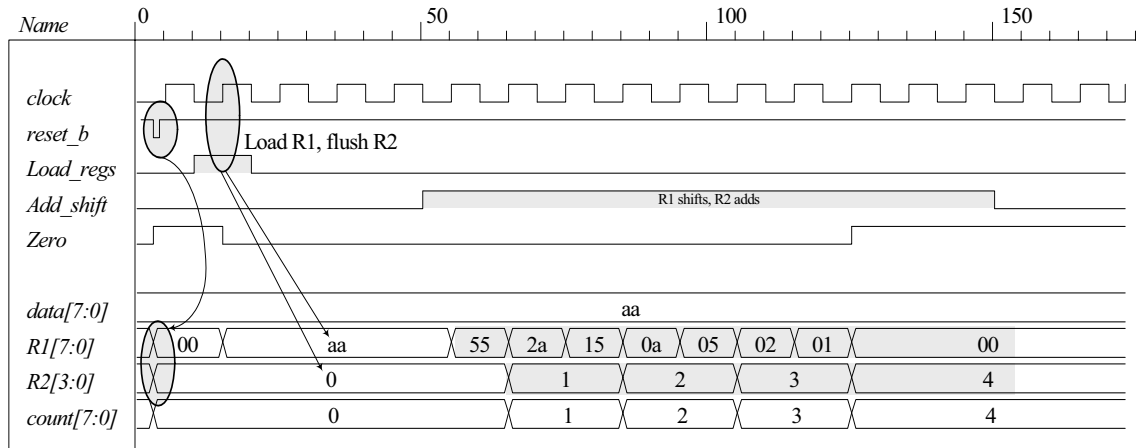

```

module Controller_2_Beh (
  output Ready,
  output reg Load_regs,
  Add_shift,
  input Start, Zero, clock, reset_b
);
  parameter S_idle = 0, S_running = 1;
  reg state, next_state;
  assign Ready = (state == S_idle);

  always @ (posedge clock, negedge reset_b)
    if (reset_b == 0) state <= S_idle;
    else state <= next_state;

  always @ (state, Start, Zero) begin
    next_state = S_idle;
    Load_regs = 0;
    Add_shift = 0;

    case (state)
      S_idle: if (Start) begin Load_regs = 1; next_state = S_running; end
      S_running: if (Zero) next_state = S_idle;
                else begin Add_shift = 1; next_state = S_running; end
    endcase
  end
endmodule

module t_Controller_2_Beh ();
  wire Ready, Load_regs, Add_shift;
  reg Start, Zero, clock, reset_b;

  Controller_2_Beh M0 (Ready, Load_regs, Add_shift, Start, Zero, clock, reset_b);

  initial #250 $finish;
  initial begin clock = 0; forever #5 clock = ~clock; end
  initial begin reset_b = 0; #2 reset_b = 1; end
  initial fork
    Zero = 1;
    Start = 0;
    #20 Start = 1; // Cycle from S_idle to S_1
    #80 Start = 0;
    #70 Zero = 0; // S_idle to S_1 to S_idle
  end
end

```

```

#90 Zero = 1; // Return to S_idle
join
endmodule

```

Note: The state transitions and outputs of the controller match the ASMD chart.

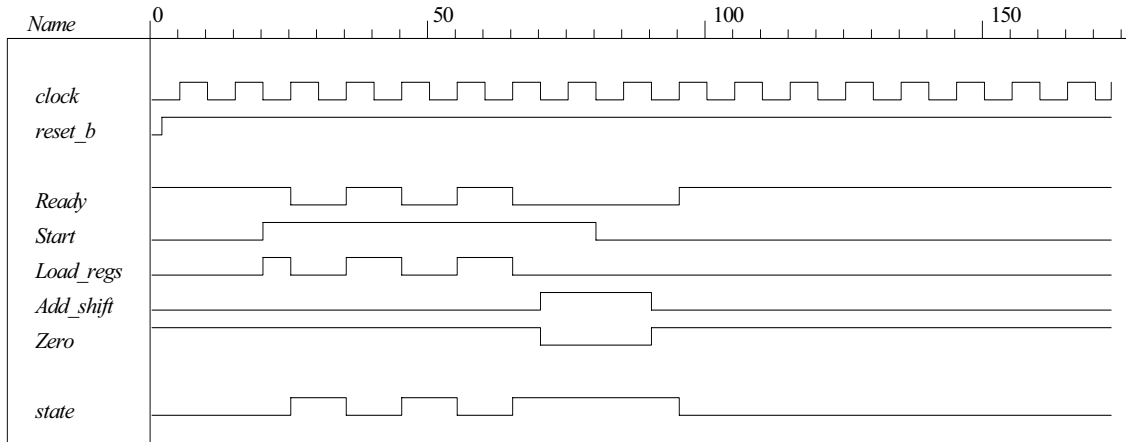

```

module Count_of_Ones_2_Beh #(parameter dp_width = 8, R2_width = 4)
(
  output [R2_width -1: 0] count,
  output Ready,
  input [dp_width -1: 0] data,
  input Start, clock, reset_b
);
  wire Load_regs, Add_shift, Zero;

  Controller_2_Beh M0 (Ready, Load_regs, Add_shift, Start, Zero, clock, reset_b);
  Datapath_Unit_2_Beh M1 (count, Zero, data, Load_regs, Add_shift, clock, reset_b);
endmodule

```

// Test plan for integrated system  
// Test for data values of 8'haa, 8'h00, 8'hff.

// Test bench for integrated system

```

module t_Count_Ones_2_Beh ();
  parameter dp_width = 8, R2_width = 4;
  wire [R2_width -1: 0] count;
  reg [dp_width -1: 0] data;
  reg Start, clock, reset_b;

  Count_of_Ones_2_Beh M0 (count, Ready, data, Start, clock, reset_b);

  initial #700 $finish;
  initial begin clock = 0; forever #5 clock = ~clock; end
  initial begin reset_b = 0; #2 reset_b = 1; end
  initial fork
    data = 8'haa; // Expect count = 4
    Start = 0;
    #20 Start = 1;
    #30 Start = 0;
    #40 data = 8'b00; // Expect count = 0
    #120 Start = 1;
    #130 Start = 0;
  join
endmodule

```

```
#140 data = 8'hff;
#160 Start = 1;
#170 Start = 0;
```

```
join
endmodule
```

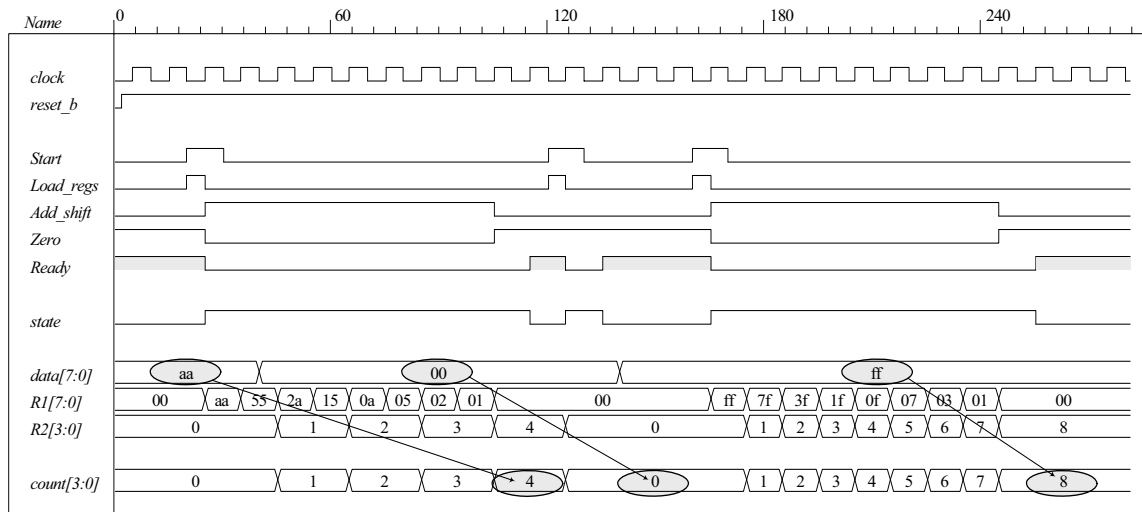

(c)  $T_0, T_1$  are to be asserted when the state is in  $S\_idle, S\_running$ , respectively. Let  $D_0, D_1$  denote the inputs to the one-hot flip-flops.

$$D_0 = T_0 Start' + T_1 Zero$$

$$D_1 = T_0 Start + T_1 E'$$

(d) Gate-level one-hot controller

```
module Controller_2_Gates_1Hot
(
  output Ready, Load_regs, Add_shift,
  input Start, Zero, clock, reset_b
);
  wire w1, w2, w3, w4;
  wire T0, T1;
  wire set;
  assign Ready = T0;
  assign Add_shift = T1;
  and (Load_regs, T0, Start);
  not (set, reset_b);
  DFF_S M0 (T0, D0, clock, set); // Note: reset action must initialize S_idle = 2'b01
  DFF M1 (T1, D1, clock, reset_b);

  not (Start_b, Start);
  not (Zero_b, Zero);
  and (w1, T0, Start_b);
  and (w2, T1, Zero);
  or (D0, w1, w2);

  and (w3, T0, Start);
  and (w4, T1, Zero_b);
  or (D1, w3, w4);
endmodule
```

```
module DFF (output reg Q, input D, clock, reset_b);
  always @ (posedge clock, negedge reset_b)
    if (reset_b == 0) Q <= 0;
    else Q <= D;
endmodule
module DFF_S (output reg Q, input D, clock, set);
  always @ (posedge clock, posedge set)
    if (set == 1) Q <= 1;
    else Q <= D;
endmodule

// Test plan for Control Unit
// Verify that state enters S_idle with reset_b asserted.
// With reset_b de-asserted, verify that state enters S_running and asserts Load_Regs when
// Start is asserted.
// Verify that state returns to S_idle from S_running if Zero is asserted.
// Verify that state goes to S_running if Zero is not asserted.

// Test bench for One-Hot Control Unit

module t_Control_Unit ();
  wire Ready, Load_regs, Add_shift;
  reg Start, Zero, clock, reset_b;
  wire [3:0] state = {M0.T1, M0.T0}; // Observe one-hot state bits

  Controller_2_Gates_1Hot M0 (Ready, Load_regs, Add_shift, Start, Zero, clock, reset_b);

  initial #250 $finish;
  initial begin clock = 0; forever #5 clock = ~clock; end
  initial begin reset_b = 0; #2 reset_b = 1; end
  initial fork
    Zero = 1;
    Start = 0;
    #20 Start = 1; // Cycle from S_idle to S_1
    #80 Start = 0;
    #70 Zero = 0; // S_idle to S_1 to S_idle
    #90 Zero = 1; // Return to S_idle
  join
endmodule
```

Simulation results show that the controller matches the ASMD chart.

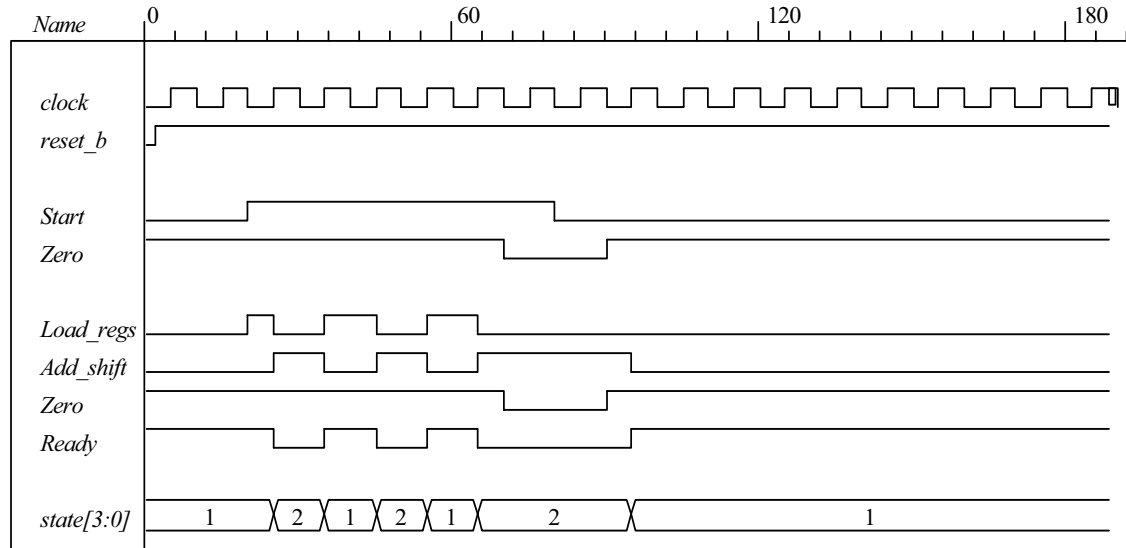

// Datapath unit – structural model

```

module Datapath_2_STR
#(parameter dp_width = 8, R2_width = 4)
(
  output [R2_width -1: 0]    count,
  output                    Zero,
  input [dp_width -1: 0]    data,
  input                    Load_regs, Add_shift, clock, reset_b);
  supply1                    pwr;
  supply0                    gnd;
  wire [dp_width -1: 0] R1_Dbus, R1;
  wire [R2_width -1: 0] R2_Dbus;
  wire DR1_0, DR1_1, DR1_2, DR1_3, DR1_4, DR1_5, DR1_6, DR1_7;
  wire R1_0, R1_1, R1_2, R1_3, R1_4, R1_5, R1_6, R1_7;
  wire R2_0, R2_1, R2_2, R2_3;
  wire [R2_width -1: 0] R2 = {R2_3, R2_2, R2_1, R2_0};
  assign count = {R2_3, R2_2, R2_1, R2_0};
  assign R1 = { R1_7, R1_6, R1_5, R1_4, R1_3, R1_2, R1_1, R1_0};
  assign DR1_0 = R1_Dbus[0];
  assign DR1_1 = R1_Dbus[1];
  assign DR1_2 = R1_Dbus[2];
  assign DR1_3 = R1_Dbus[3];
  assign DR1_4 = R1_Dbus[4];
  assign DR1_5 = R1_Dbus[5];
  assign DR1_6 = R1_Dbus[6];
  assign DR1_7 = R1_Dbus[7];

  nor (Zero, R1_0, R1_1, R1_2, R1_3, R1_4, R1_5, R1_6, R1_7);
  not (Load_regs_b, Load_regs);

  DFF DF_0 (R1_0, DR1_0, clock, pwr);    // Disable reset
  DFF DF_1 (R1_1, DR1_1, clock, pwr);
  DFF DF_2 (R1_2, DR1_2, clock, pwr);
  DFF DF_3 (R1_3, DR1_3, clock, pwr);
  DFF DF_4 (R1_4, DR1_4, clock, pwr);
  DFF DF_5 (R1_5, DR1_5, clock, pwr);
  DFF DF_6 (R1_6, DR1_6, clock, pwr);
  DFF DF_7 (R1_7, DR1_7, clock, pwr);

```

```
DFF DR_0 (R2_0, DR2_0, clock, Load_regs_b); // Load_regs (set) drives R2 to all ones
DFF DR_1 (R2_1, DR2_1, clock, Load_regs_b);
DFF DR_2 (R2_2, DR2_2, clock, Load_regs_b);
DFF DR_3 (R2_3, DR2_3, clock, Load_regs_b);

assign DR2_0 = R2_Dbus[0];
assign DR2_1 = R2_Dbus[1];
assign DR2_2 = R2_Dbus[2];
assign DR2_3 = R2_Dbus[3];

wire [1: 0]          sel = {Add_shift, Load_regs};
wire [dp_width -1: 0] R1_shifted = {1'b0, R1_7, R1_6, R1_5, R1_4, R1_3, R1_2, R1_1};
wire [R2_width -1: 0] sum = R2 + {3'b000, R1[0]};

Mux8_4_x_1 M0 (R1_Dbus, R1, data, R1_shifted, R1, sel);
Mux4_2_x_1 M1 (R2_Dbus, R2, sum, Add_shift);
endmodule
```

```
module Mux8_4_x_1 #(parameter dp_width = 8) (output reg [dp_width -1: 0] mux_out,  
input [dp_width -1: 0] in0, in1, in2, in3, input [1: 0] sel);  
always @ (in0, in1, in2, in3, sel)  
  case (sel)  
    2'b00: mux_out = in0;  
    2'b01: mux_out = in1;  
    2'b10: mux_out = in2;  
    2'b11: mux_out = in3;  
  endcase  
endmodule  
  
module Mux4_2_x_1 #(parameter dp_width = 4) (output [dp_width -1: 0] mux_out,  
input [dp_width -1: 0] in0, in1, input sel);  
assign mux_out = sel ? in1: in0;  
endmodule  
  
// Test Plan for Datapath Unit:  
// Demonstrate action of Load_regs  
// R1 gets data, R2 gets all ones  
// Demonstrate action of Incr_R2  
// Demonstrate action of Add_shift and detect Zero  
  
// Test bench for datapath  
  
module t_Datapath_Unit  
#(parameter dp_width = 8, R2_width = 4)  
( );  
wire [R2_width -1: 0] count;  
wire Zero;  
reg [dp_width -1: 0] data;  
  reg Load_regs, Add_shift, clock, reset_b;  
  
Datapath_2_STR M0 (count, Zero, data, Load_regs, Add_shift, clock, reset_b);  
  
initial #250 $finish;  
initial begin clock = 0; forever #5 clock = ~clock; end  
initial begin reset_b = 0; #2 reset_b = 1; end  
initial fork  
  data = 8'haa;  
  Load_regs = 0;  
  Add_shift = 0;  
  #10 Load_regs = 1;  
  #20 Load_regs = 0;  
  #50 Add_shift = 1;  
  #140 Add_shift = 0;  
join  
endmodule
```



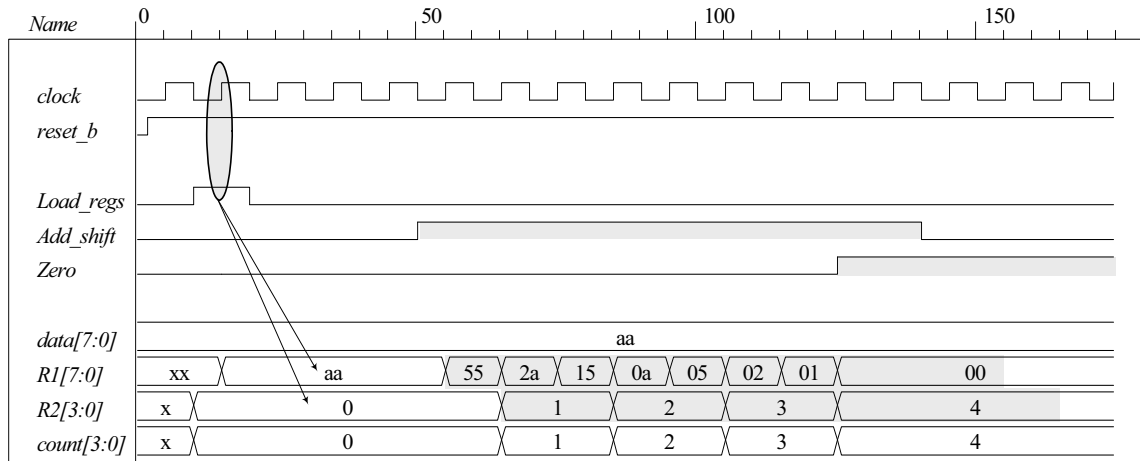

// Integrated system

```

module Count_Ones_2_Gates_1Hot_STR
# (parameter dp_width = 8, R2_width = 4)
(
  output [R2_width -1: 0] count,
  input [dp_width -1: 0] data,
  input Start, clock, reset_b
);
wire Load_regs, Add_shift, Zero;
  Controller_2_Gates_1Hot M0 (Ready, Load_regs, Add_shift, Start, Zero, clock, reset_b);
  Datapath_2_STR M1 (count, Zero, data, Load_regs, Add_shift, clock, reset_b);
endmodule

```

// Test plan for integrated system  
 // Test for data values of 8'haa, 8'h00, 8'hff.

// Test bench for integrated system

```

module t_Count_Ones_2_Gates_1Hot_STR ();
parameter dp_width = 8, R2_width = 4;
wire [R2_width -1: 0] count;
reg [dp_width -1: 0] data;
reg Start, clock, reset_b;
wire [1: 0] state = {M0.M0.T1, M0.M0.T0};

Count_Ones_2_Gates_1Hot_STR M0 (count, data, Start, clock, reset_b);

initial #700 $finish;
initial begin clock = 0; forever #5 clock = ~clock; end
initial begin reset_b = 0; #2 reset_b = 1; end
initial fork
  data = 8'haa; // Expect count = 4
  Start = 0;
  #20 Start = 1;
  #30 Start = 0;
  #40 data = 8'b00; // Expect count = 0
  #120 Start = 1;
  #130 Start = 0;
  #150 data = 8'hff; // Expect count = 8
  #200 Start = 1;
  #210 Start = 0;
join
endmodule

```

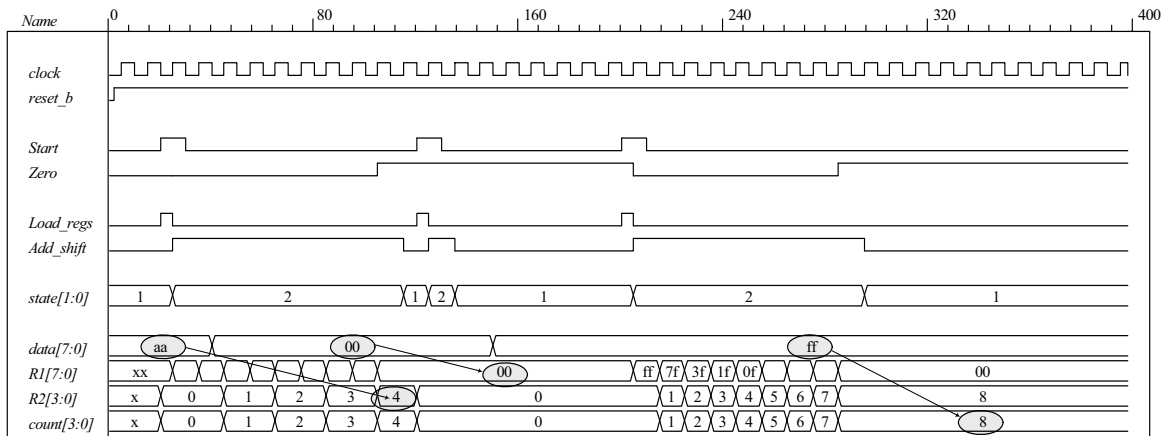

8.38

```

module Prob_8_38 (
    output reg [7: 0] Sum,
    output reg Car_Bor,
    input [7: 0] Data_A, Data_B);
    reg [7: 0] Reg_A, Reg_B;

    always @ (Data_A, Data_B)
        case ({Data_A[7], Data_B[7]})
            2'b00, 2'b11: begin // ++, --
                {Car_Bor, Sum[6: 0]} = Data_A[6: 0] + Data_B[6: 0];
                Sum[7] = Data_A[7];
            end

            default: if (Data_A[6: 0] >= Data_B[6: 0]) begin // +-, -+
                {Car_Bor, Sum[6: 0]} = Data_A[6: 0] - Data_B[6: 0];
                Sum[7] = Data_A[7];
            end
            else begin
                {Car_Bor, Sum[6: 0]} = Data_B[6: 0] - Data_A[6: 0];
                Sum[7] = Data_B[7];
            end
        endcase
    endmodule

    module t_Prob_8_38 ();
        wire [7: 0] Sum;
        wire Car_Bor;
        reg [7: 0] Data_A, Data_B;
        wire [6: 0] Mag_A, Mag_B;
        assign Mag_A = M0.Data_A[6: 0]; // Hierarchical dereferencing
        assign Mag_B = M0.Data_B[6: 0];
        wire Sign_A = M0.Data_A[7];
        wire Sign_B = M0.Data_B[7];
        wire Sign = Sum[7];
        wire [7: 0] Mag = Sum[6: 0];

        Prob_8_38 M0 (Sum, Car_Bor, Data_A, Data_B);

        initial #650 $finish;
    
```

**initial fork**

```

// Addition
// A B
#0 begin Data_A = {1'b0, 7'd25}; Data_B = {1'b0, 7'd10}; end //+25, +10
#40 begin Data_A = {1'b1, 7'd25}; Data_B = {1'b1, 7'd10}; end // -25, -10
#80 begin Data_A = {1'b1, 7'd25}; Data_B = {1'b0, 7'd10}; end // -25, +10
#120 begin Data_A = {1'b0, 7'd25}; Data_B = {1'b1, 7'd10}; end // 25, -10
// B A
#160 begin Data_B = {1'b0, 7'd25}; Data_A = {1'b0, 7'd10}; end //+25, +10
#200 begin Data_B = {1'b1, 7'd25}; Data_A = {1'b1, 7'd10}; end // -25, -10

#240 begin Data_B = {1'b1, 7'd25}; Data_A = {1'b0, 7'd10}; end // -25, +10
#280 begin Data_B = {1'b0, 7'd25}; Data_A = {1'b1, 7'd10}; end // +25, -10
// Addition of matching numbers

#320 begin Data_A = {1'b1,7'd0}; Data_B = {1'b1,7'd0}; end // -0, -0
#360 begin Data_A = {1'b0,7'd0}; Data_B = {1'b0,7'd0}; end // +0, +0
#400 begin Data_A = {1'b0,7'd0}; Data_B = {1'b1,7'd0}; end // +0, -0
#440 begin Data_A = {1'b1,7'd0}; Data_B = {1'b0,7'd0}; end // -0, +0

#480 begin Data_B = {1'b0, 7'd25}; Data_A = {1'b0, 7'd25}; end // matching +
#520 begin Data_B = {1'b1, 7'd25}; Data_A = {1'b1, 7'd25}; end // matching -

// Test of carry (negative numbers)
#560 begin Data_A = 8'hf0; Data_B = 8'hf0; end // carry - -
// Test of carry (positive numbers)
#600 begin Data_A = 8'h70; Data_B = 8'h70; end // carry ++
join
endmodule

```

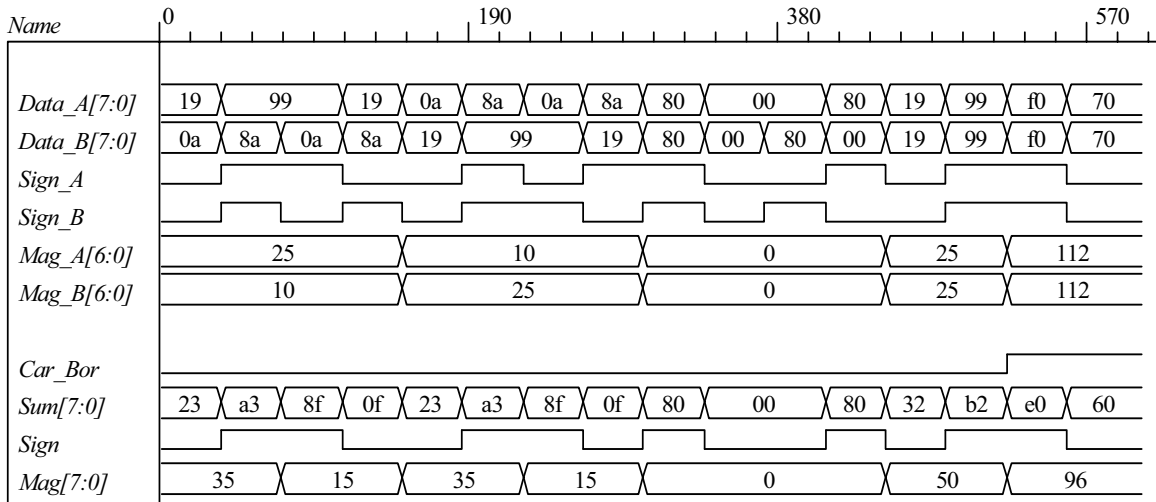

8.39 Block diagram and ASMD chart:

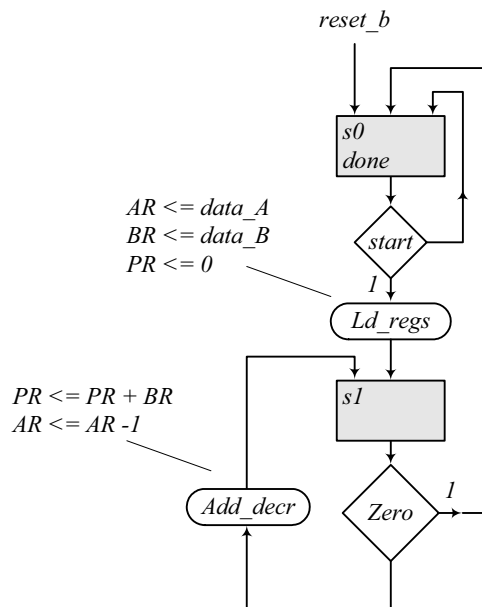
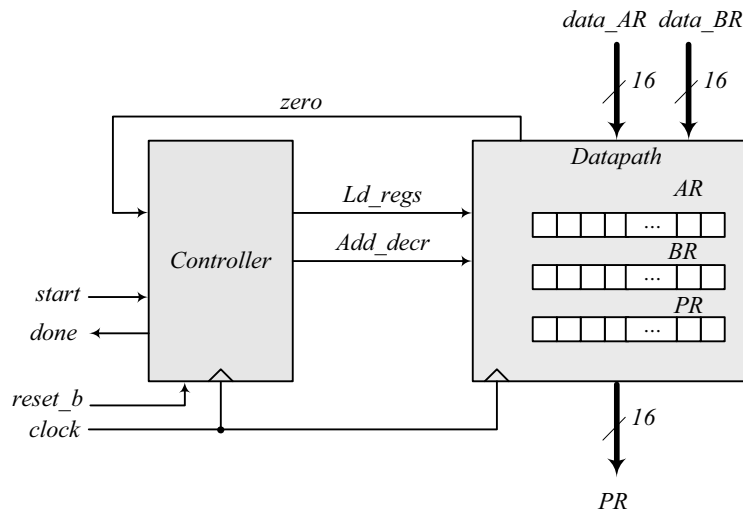

```

module Prob_8_39 (
  output [15: 0] PR, output done,
  input [7: 0] data_AR, data_BR, input start, clock, reset_b
);

```

```

  Controller_P8_39 M0 (done, Ld_regs, Add_decr, start, zero, clock, reset_b);

```

```

  Datapath_P8_39 M1 (PR, zero, data_AR, data_BR, Ld_regs, Add_decr, clock, reset_b);
endmodule

```

```

module Controller_P8_16 (output done, output reg Ld_regs, Add_decr, input start, zero, clock, reset_b);
  parameter s0 = 1'b0, s1 = 1'b1;
  reg state, next_state;
  assign done = (state == s0);

```

```
always @ (posedge clock, negedge reset_b)
  if (!reset_b) state <= s0; else state <= next_state;

always @ (state, start, zero) begin
  Ld_regs = 0;
  Add_decr = 0;
  case (state)
    s0:    if (start) begin Ld_regs = 1; next_state = s1; end
    s1:    if (zero) next_state = s0; else begin next_state = s1; Add_decr = 1; end
    default: next_state = s0;
  endcase
end
endmodule

module Datapath_P8_16 (
  output reg [15: 0] PR, output zero,
  input [7: 0] data_AR, data_BR, input Ld_regs, Add_decr, clock, reset_b
);

  reg [7: 0] AR, BR;
  assign zero = ~( | AR);

  always @ (posedge clock, negedge reset_b)
    if (!reset_b) begin AR <= 8'b0; BR <= 8'b0; PR <= 16'b0; end
    else begin
      if (Ld_regs) begin AR <= data_AR; BR <= data_BR; PR <= 0; end
      else if (Add_decr) begin PR <= PR + BR; AR <= AR -1; end
    end
  end
endmodule

// Test plan – Verify;
// Power-up reset
// Data is loaded correctly
// Control signals assert correctly
// Status signals assert correctly
// start is ignored while multiplying
// Multiplication is correct
// Recovery from reset on-the-fly

module t_Prob_P8_16;
  wire done;
  wire [15: 0] PR;
  reg [7: 0] data_AR, data_BR;
  reg start, clock, reset_b;

  Prob_8_16 M0 (PR, done, data_AR, data_BR, start, clock, reset_b);

  initial #500 $finish;
  initial begin clock = 0; forever #5 clock = ~clock; end
  initial fork
    reset_b = 0;
    #12 reset_b = 1;
    #40 reset_b = 0;
    #42 reset_b = 1;
    #90 reset_b = 1;
    #92 reset_b = 1;
  join
endmodule
```

**initial fork**

```
#20 start = 1;
#30 start = 0;
#40 start = 1;
#50 start = 0;
#120 start = 1;
#120 start = 0;
```

**join**

**initial fork**

```
data_AR = 8'd5;    // AR > 0
data_BR = 8'd20;
```

```
#80 data_AR = 8'd3;
#80 data_BR = 8'd9;
```

```
#100 data_AR = 8'd4;
#100 data_BR = 8'd9;
```

**join**

**endmodule**

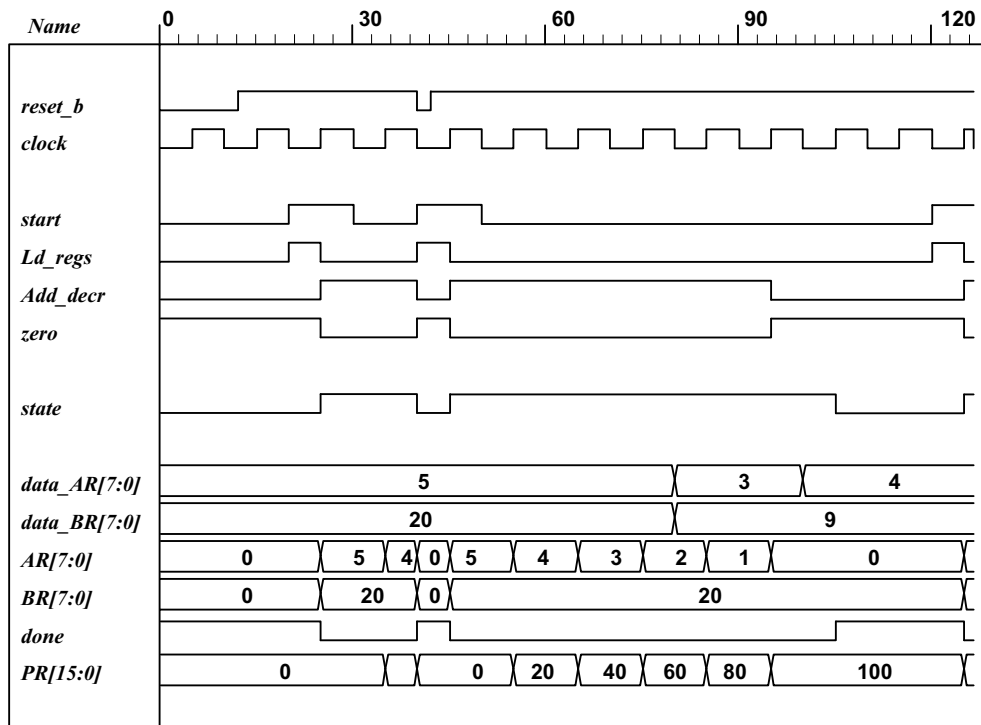

8.40

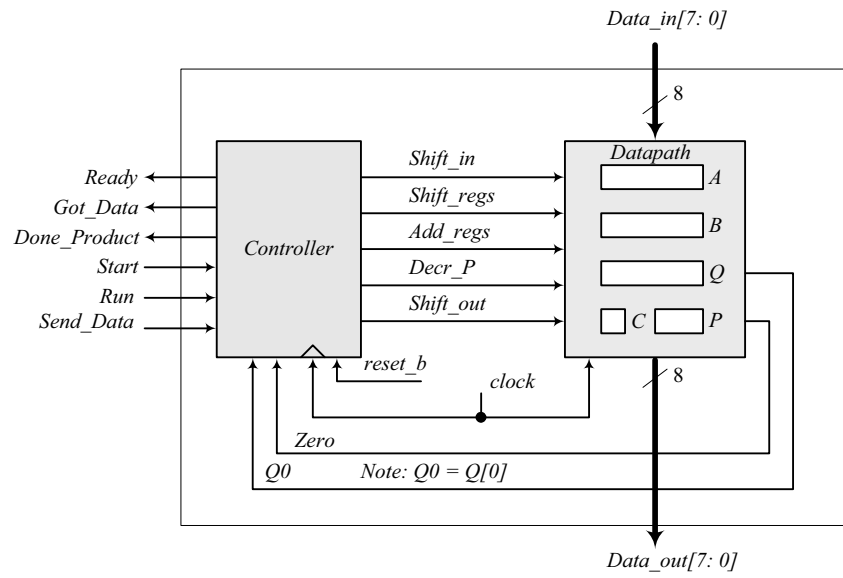

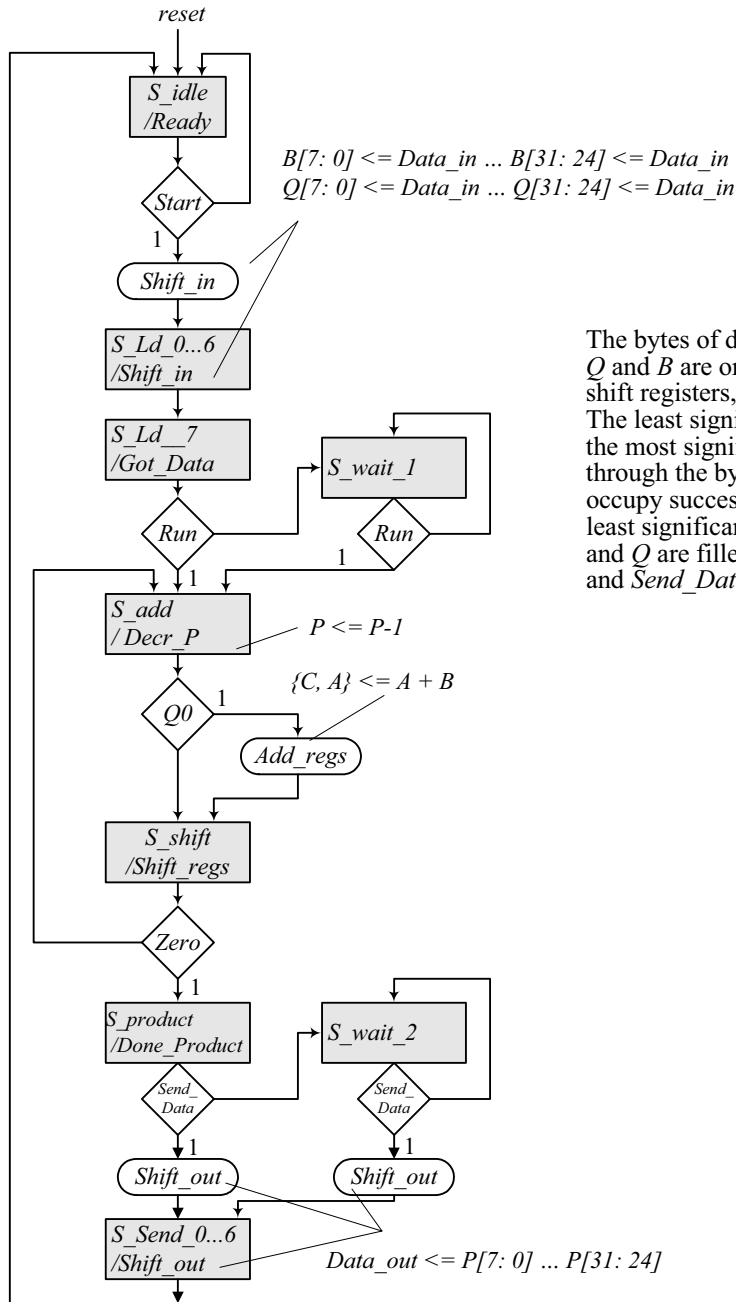

The bytes of data will be read sequentially. Registers *Q* and *B* are organized to act as byte-wide parallel shift registers, taking 8 clock cycles to fill the pipe. The least significant byte of the multiplicand enters the most significant byte of *Q* and then moves through the bytes of *Q* to enter *B*, then proceed to occupy successive bytes of *B* until it occupies the least significant byte of *B*, and so forth until both *B* and *Q* are filled. Wait states are used to wait for *Run* and *Send\_Data*.



```
module Prob_8_40 (  
    output [7: 0] Data_out,  
    output Ready, Got_Data, Done_Product,  
    input [7: 0] Data_in,  
    input Start, Run, Send_Data, clock, reset_b  
);  
  
Controller M0 (  
    Ready, Shift_in, Got_Data, Done_Product, Decr_P, Add_regs, Shift_regs, Shift_out,  
    Start, Run, Send_Data, Zero, Q0, clock, reset_b  
);  
Datapath M1(Data_out, Q0, Zero, Data_in,  
    Start, Shift_in, Decr_P, Add_regs, Shift_regs, Shift_out, clock  
);  
endmodule  
  
module Controller (  
    output reg Ready, Shift_in, Got_Data, Done_Product, Decr_P, Add_regs,  
    Shift_regs, Shift_out,  
    input Start, Run, Send_Data, Zero, Q0, clock, reset_b  
);  
  
parameter S_idle = 5'd20,  
    S_Ld_0 = 5'd0,  
    S_Ld_1 = 5'd1,  
    S_Ld_2 = 5'd2,  
    S_Ld_3 = 5'd3,  
    S_Ld_4 = 5'd4,  
    S_Ld_5 = 5'd5,  
    S_Ld_6 = 5'd6,  
    S_Ld_7 = 5'd7,  
    S_wait_1 = 5'd8, // Wait state  
    S_add = 5'd9,  
    S_Shift = 5'd10,  
    S_product = 5'd11,  
    S_wait_2 = 5'd12, // Wait state  
    S_Send_0 = 5'd13,  
    S_Send_1 = 5'd14,  
    S_Send_2 = 5'd15,  
    S_Send_3 = 5'd16,  
    S_Send_4 = 5'd17,  
    S_Send_5 = 5'd18,  
    S_Send_6 = 5'd19;  
  
reg [4: 0] state, next_state;  
  
always @ (posedge clock, negedge reset_b)  
    if (~reset_b) state <= S_idle; else state <= next_state;  
  
always @ (state, Start, Run, Q0, Zero, Send_Data) begin  
    next_state = S_idle; // Prevent accidental synthesis of latches  
    Ready = 0;  
    Shift_in = 0;  
    Shift_regs = 0;  
    Add_regs = 0;  
    Decr_P = 0;  
    Shift_out = 0;  
    Got_Data = 0;  
    Done_Product = 0;
```

```

case (state) // Assign by exception to default values
  S_idle: begin
    Ready = 1;
    if (Start) begin next_state = S_Ld_0; Shift_in = 1; end
  end
  S_Ld_0: begin next_state = S_Ld_1; Shift_in = 1; end
  S_Ld_1: begin next_state = S_Ld_2; Shift_in = 1; end
  S_Ld_2: begin next_state = S_Ld_3; Shift_in = 1; end
  S_Ld_3: begin next_state = S_Ld_4; Shift_in = 1; end
  S_Ld_4: begin next_state = S_Ld_5; Shift_in = 1; end
  S_Ld_5: begin next_state = S_Ld_6; Shift_in = 1; end
  S_Ld_6: begin next_state = S_Ld_7; Shift_in = 1; end
  S_Ld_7: begin Got_Data = 1;
    if (Run) next_state = S_add;
    else next_state = S_wait_1;
  end
  S_wait_1: if (Run) next_state = S_add; else next_state = S_wait_1;
  S_add: begin next_state = S_Shift; Decr_P = 1; if (Q0) Add_regs = 1; end
  S_Shift: begin Shift_regs = 1; if (Zero) next_state = S_product;
    else next_state = S_add; end
  S_product: begin
    Done_Product = 1;
    if (Send_Data) begin next_state = S_Send_0; Shift_out = 1; end
    else next_state = S_wait_2; end
  S_wait_2: if (Send_Data) begin next_state = S_Send_0; Shift_out = 1; end
    else next_state = S_wait_2;
  S_Send_0: begin next_state = S_Send_1; Shift_out = 1; end
  S_Send_1: begin next_state = S_Send_2; Shift_out = 1; end
  S_Send_2: begin next_state = S_Send_3; Shift_out = 1; end
  S_Send_3: begin next_state = S_Send_4; Shift_out = 1; end
  S_Send_4: begin next_state = S_Send_5; Shift_out = 1; end
  S_Send_5: begin next_state = S_Send_6; Shift_out = 1; end
  S_Send_6: begin next_state = S_idle; Shift_out = 1; end
  default: next_state = S_idle;
endcase
end
endmodule

module Datapath #(parameter dp_width = 32, P_width = 6) (
  output [7: 0] Data_out,
  output Q0, Zero,
  input [7: 0] Data_in,
  input Start, Shift_in, Decr_P, Add_regs, Shift_regs, Shift_out, clock
);
reg [dp_width - 1: 0] A, B, Q; // Sized for datapath
reg C;
reg [P_width - 1: 0] P;
assign Q0 = Q[0];
assign Zero = (P == 0); // counter is zero
assign Data_out = {C, A, Q};

always @ (posedge clock) begin
  if (Shift_in) begin
    P <= dp_width;
    A <= 0;
    C <= 0;
    B[7: 0] <= B[15: 8]; // Treat B and Q registers as a pipeline to load data bytes
    B[15: 8] <= B[23: 16];
    B[23: 16] <= B[31: 24];
    B[31: 24] <= Q[7: 0];
    Q[7: 0] <= Q[15: 8];
  end

```

```

    Q[15: 8]  <= Q[ 23: 16];
    Q[23: 16] <= Q[31: 24];
    Q[31: 24] <= Data_in;
end
if (Add_regs) {C, A} <= A + B;
if (Shift_regs) {C, A, Q} <= {C, A, Q} >> 1;
if (Decr_P) P <= P -1;
if (Shift_out) begin {C, A, Q} <= {C, A, Q} >> 8; end
end
endmodule

module t_Prob_8_40;
parameter      dp_width = 32;           // Width of datapath
wire [7: 0]    Data_out;
wire          Ready, Got_Data, Done_Product;
reg           Start, Run, Send_Data, clock, reset_b;

integer       Exp_Value;
reg           Error;
wire [7: 0]   Data_in;
reg [dp_width -1: 0] Multiplicand, Multiplier;
reg [2*dp_width -1: 0] Data_register;    // For test patterns
assign       Data_in = Data_register [7:0];
wire [2*dp_width -1: 0] product;
assign      product = {M0.M1.C, M0.M1.A, M0.M1.Q};
Prob_8_40 M0 (
    Data_out, Ready, Got_Data, Done_Product, Data_in, Start, Run, Send_Data, clock, reset_b
);

initial #2000 $finish;
initial begin clock = 0; forever #5 clock = ~clock; end
initial fork
    reset_b = 1;
    #2 reset_b = 0;
    #3 reset_b = 1;
join
initial fork
    Start = 0;
    Run = 0;
    Send_Data = 0;
    #10 Start = 1;
    #20 Start = 0;

    #50 Run = 1;      // Ignored by controller
    #60 Run = 0;
    #120 Run = 1;
    #130 Run = 0;

    #830 Send_Data = 1;
    #840 Send_Data = 0;
join
// Test patterns for multiplication

initial begin
    Multiplicand = 32'h0f_00_00_aa;
    Multiplier = 32'h0a_00_00_ff;
    Data_register = {Multiplier, Multiplicand};
end

initial begin          // Synchronize input data bytes

```

```
@ (posedge Start)
repeat (15) begin
  @ (negedge clock)
    Data_register <= Data_register >> 8;
end
end
endmodule
```

Simulation results: Loading multiplicand (0f0000aa<sub>H</sub>) and multiplier (0a0000ff<sub>H</sub>), 4 bytes each, in sequence, beginning with the least significant byte of the multiplicand.

Note: *Product* is not valid until *Done\_Product* asserts. The value of *Product* shown here (255<sub>10</sub>) reflects the contents of {*C*, *A*, *Q*} after the multiplier has been loaded, prior to multiplication.

Note: The machine ignores a premature assertion of *Run*.

Note: *Got\_Data* asserts at the 8<sup>th</sup> clock after *Start* asserts, i.e., 8 clocks to load the data.

Note: *Product*, *Multiplier*, and *Multiplicand* are formed in the test bench.

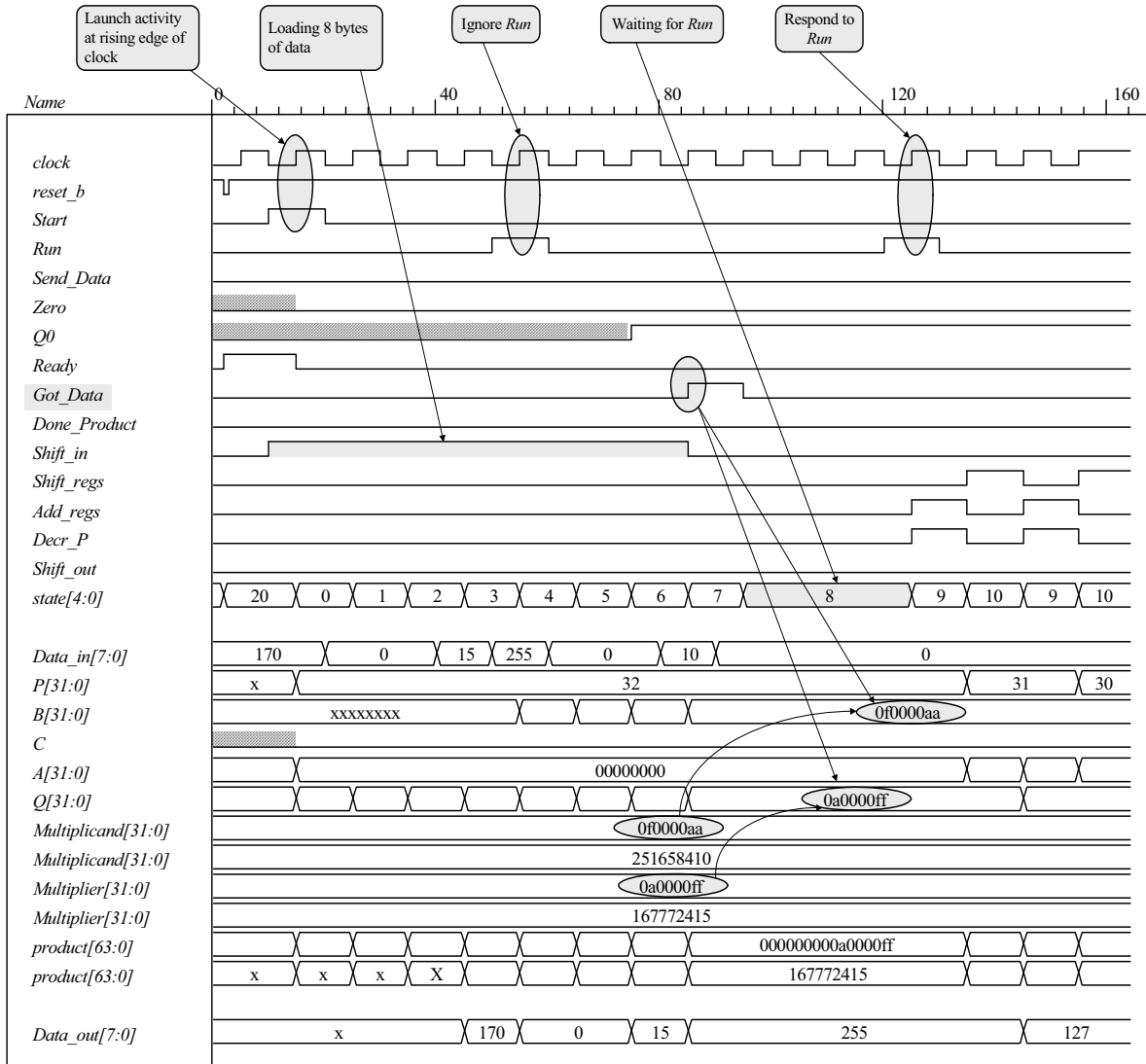

Note: Product (64 bits) is formed correctly

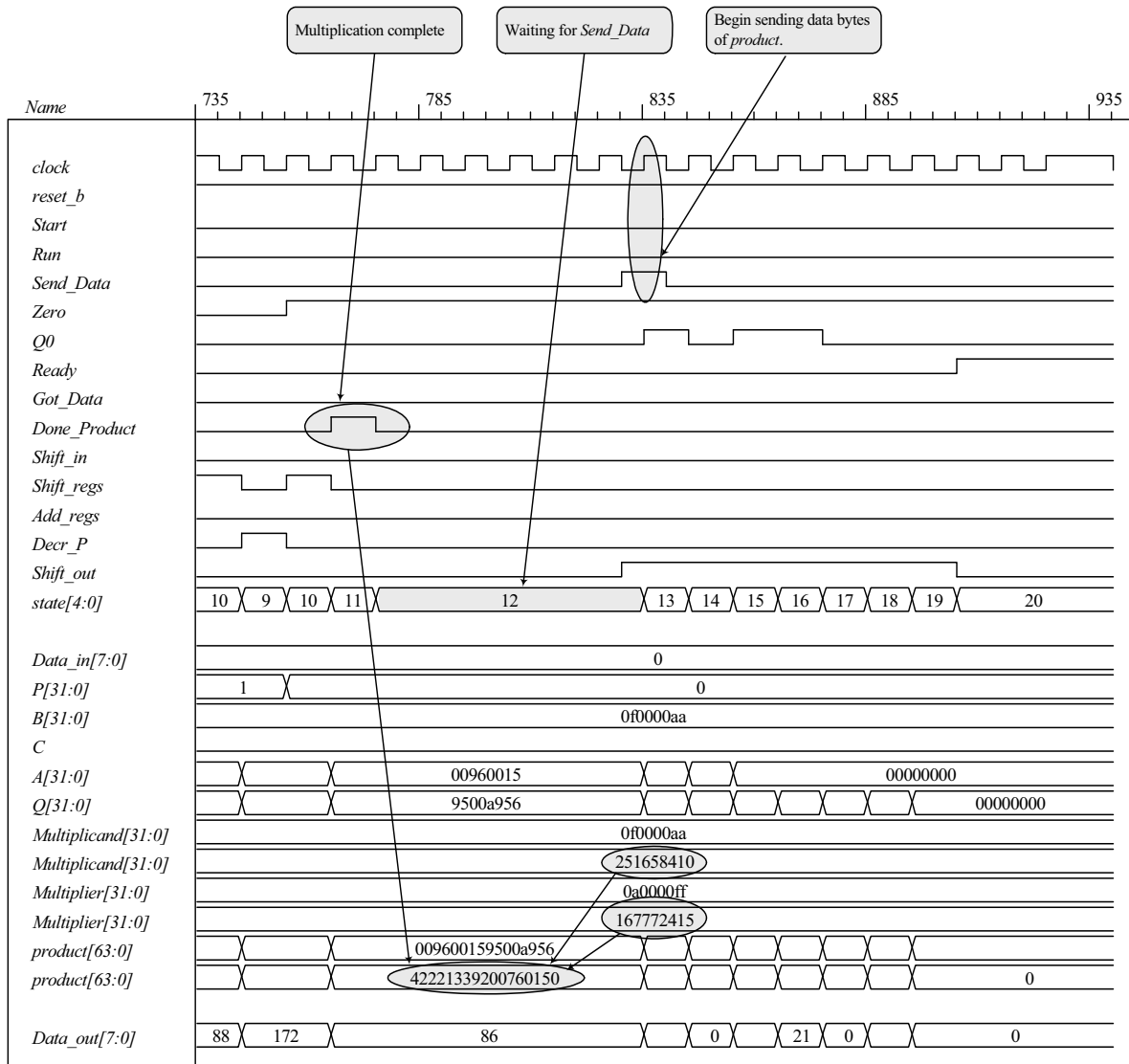

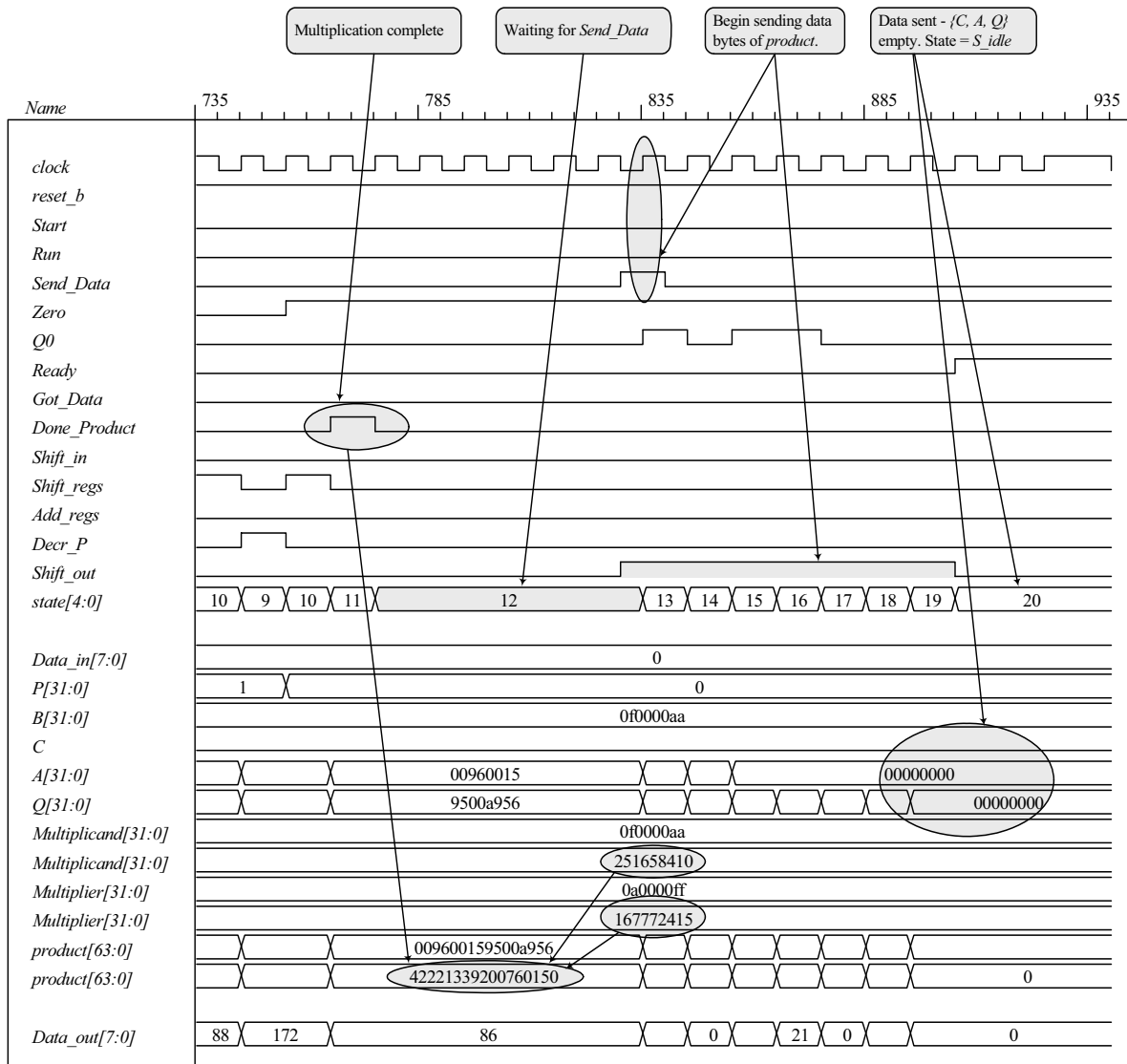

8.41 (a)

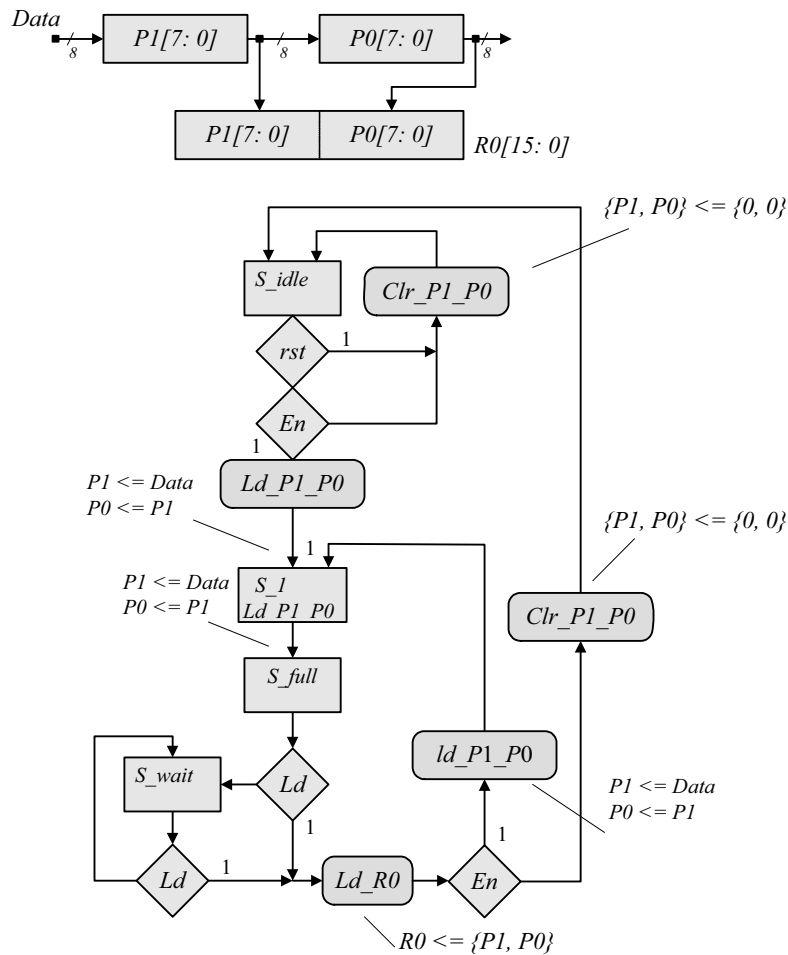

(b) HDL model, test bench and simulation results for datapath unit.

```

module Datapath_unit
(
  output reg [15: 0] R0, input [7: 0] Data, input Clr_P1_P0, Ld_P1_P0, Ld_R0, clock, rst);
  reg [7: 0] P1, P0;

  always @ (posedge clock) begin
    if (Clr_P1_P0) begin P1 <= 0; P0 <= 0; end
    if (Ld_P1_P0) begin P1 <= Data; P0 <= P1; end
    if (Ld_R0) R0 <= {P1, P0};
  end
endmodule

```



```
// Test bench for datapath
module t_Datapath_unit ();
  wire [15: 0] R0;
  reg [7: 0] Data;
  reg Clr_P1_P0, Ld_P1_P0, Ld_R0, clock, rst;

  Datapath_unit M0 (R0, Data, Clr_P1_P0, Ld_P1_P0, Ld_R0, clock, rst);

  initial #100 $finish;
  initial begin clock = 0; forever #5 clock = ~clock; end
  initial begin rst = 0; #2 rst = 1; end
  initial fork
    #20 Clr_P1_P0 = 0;
    #20 Ld_P1_P0 = 0;
    #20 Ld_R0 = 0;
    #20 Data = 8'ha5;
    #40 Ld_P1_P0 = 1;
    #50 Data = 8'hff;
    #60 Ld_P1_P0 = 0;
    #70 Ld_R0 = 1;
    #80 Ld_R0 = 0;
  join
endmodule
```

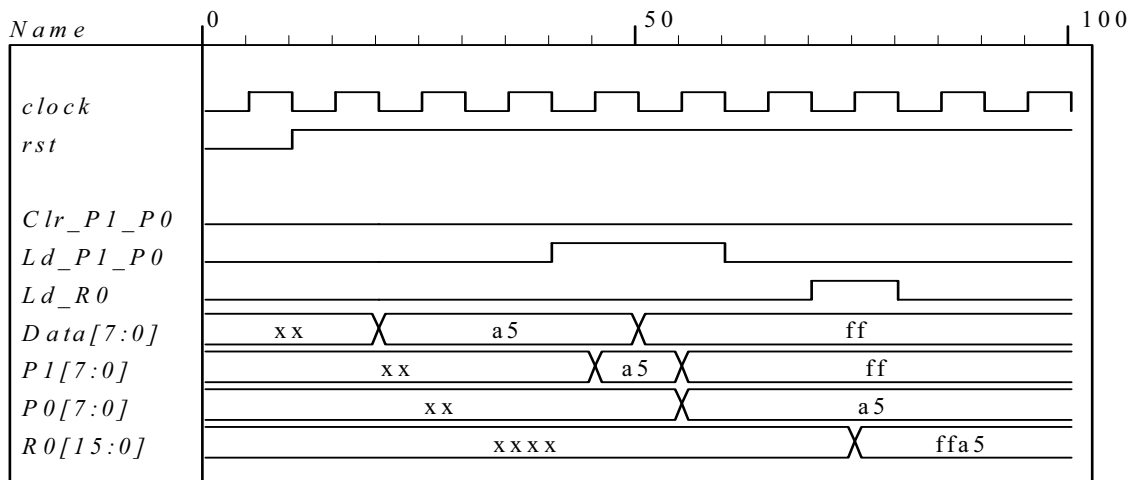

(c) HDL model, test bench, and simulation results for the control unit.

```
module Control_unit (output reg Clr_P1_P0, Ld_P1_P0, Ld_R0, input En, Ld, clock, rst);  
parameter S_idle = 4'b0001, S_1 = 4'b0010, S_full = 4'b0100, S_wait = 4'b1000;  
reg [3: 0] state, next_state;
```

```
always @ (posedge clock)  
  if (rst) state <= S_idle;  
  else state <= next_state;
```

```
always @ (state, Ld, En) begin  
  Clr_P1_P0 = 0;           // Assign by exception  
  Ld_P1_P0 = 0;  
  Ld_R0 = 0;  
  next_state = S_idle;  
  case (state)  
    S_idle:  if (En) begin Ld_P1_P0 = 1; next_state = S_1; end  
            else next_state = S_idle;  
  
    S_1:     begin Ld_P1_P0 = 1; next_state = S_full; end  
  
    S_full:  if (!Ld) next_state = S_wait;  
            else begin  
              Ld_R0 = 1;  
              if (En) begin Ld_P1_P0 = 1; next_state = S_1; end  
              else begin Clr_P1_P0 = 1; next_state = S_idle; end  
            end  
  
    S_wait:  if (!Ld) next_state = S_wait;  
            else begin  
              Ld_R0 = 1;  
              if (En) begin Ld_P1_P0 = 1; next_state = S_1; end  
              else begin Clr_P1_P0 = 1; next_state = S_idle; end  
            end  
  
    default: next_state = S_idle;  
  endcase  
end  
endmodule
```

```
// Test bench for control unit
```

```
module t_Control_unit ();  
wire Clr_P1_P0, Ld_P1_P0, Ld_R0;  
reg En, Ld, clock, rst;  
  
Control_unit M0 (Clr_P1_P0, Ld_P1_P0, Ld_R0, En, Ld, clock, rst);  
  
initial #200 $finish;  
initial begin clock = 0; forever #5 clock = ~clock; end  
initial begin rst = 0; #2 rst = 1; #12 rst = 0; end  
initial fork  
  #20 Ld = 0;  
  #20 En = 0;  
  #30 En = 1; // Drive to S_wait  
  #70 Ld = 1; // Return to S_1 to S_full tp S_wait  
  #80 Ld = 0;  
  #100 Ld = 1; // Drive to S_idle  
  #100 En = 0;  
  #110 En = 0;  
  #120 Ld = 0;  
join  
endmodule
```

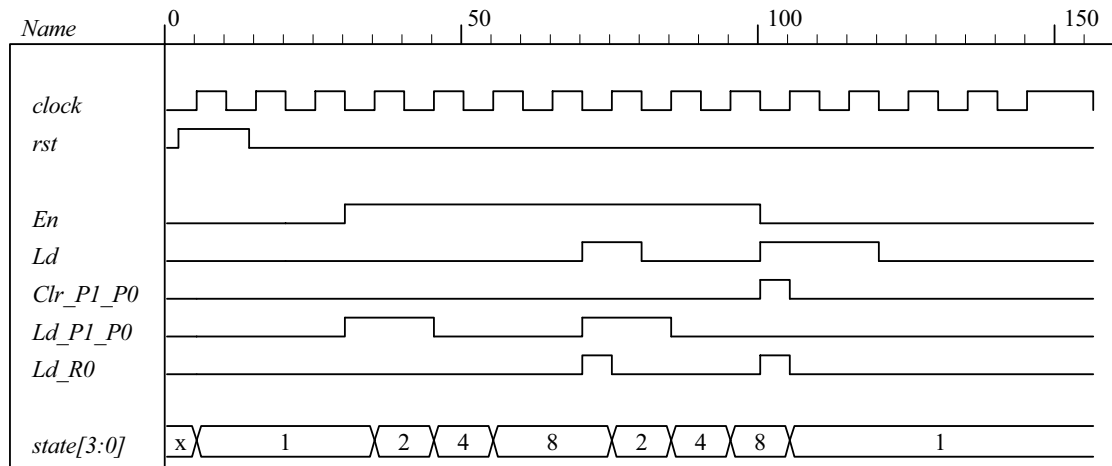

(c) Integrated system Note that the test bench for the integrated system uses the input stimuli from the test bench for the control unit and displays the waveforms produced by the test bench for the datapath unit.:

```
module Prob_8_41 (output [15: 0] R0, input [7: 0] Data, input En, Ld, clock, rst);
wire Clr_P1_P0, Ld_P1_P0, Ld_R0;
```

```
Control_unit M0 (Clr_P1_P0, Ld_P1_P0, Ld_R0, En, Ld, clock, rst);
Datapath_unit M1 (R0, Data, Clr_P1_P0, Ld_P1_P0, Ld_R0, clock);
```

**endmodule**

```
module Control_unit (output reg Clr_P1_P0, Ld_P1_P0, Ld_R0, input En, Ld, clock, rst);
parameter S_idle = 4'b0001, S_1 = 4'b0010, S_full = 4'b0100, S_wait = 4'b1000;
reg [3: 0] state, next_state;
```

```
always @ (posedge clock)
if (rst) state <= S_idle;
else state <= next_state;
```

```
always @ (state, Ld, En) begin
  Clr_P1_P0 = 0; // Assign by exception
  Ld_P1_P0 = 0;
  Ld_R0 = 0;
  next_state = S_idle;
  case (state)
    S_idle: if (En) begin Ld_P1_P0 = 1; next_state = S_1; end
           else next_state = S_idle;

    S_1: begin Ld_P1_P0 = 1; next_state = S_full; end

    S_full: if (!Ld) next_state = S_wait;
           else begin
             Ld_R0 = 1;
             if (En) begin Ld_P1_P0 = 1; next_state = S_1; end
             else begin Clr_P1_P0 = 1; next_state = S_idle; end
           end

    S_wait: if (!Ld) next_state = S_wait;
           else begin
```

```
        Ld_R0 = 1;
        if (En) begin Ld_P1_P0 = 1; next_state = S_1; end
        else begin Clr_P1_P0 = 1; next_state = S_idle; end
    end
    default: next_state = S_idle;
endcase
end
endmodule

module Datapath_unit
(
    output reg [15: 0] R0,
    input [7: 0] Data,
    input Clr_P1_P0,
    Ld_P1_P0,
    Ld_R0,
    clock);
    reg [7: 0] P1, P0;

    always @ (posedge clock) begin
        if (Clr_P1_P0) begin P1 <= 0; P0 <= 0; end
        if (Ld_P1_P0) begin P1 <= Data; P0 <= P1; end
        if (Ld_R0) R0 <= {P1, P0};
    end
endmodule

// Test bench for integrated system
module t_Prob_8_41 ();
    wire [15: 0] R0;
    reg [7: 0] Data;
    reg En, Ld, clock, rst;

    Prob_8_41 M0 (R0, Data, En, Ld, clock, rst);

    initial #200 $finish;
    initial begin clock = 0; forever #5 clock = ~clock; end
    initial begin rst = 0; #10 rst = 1; #20 rst = 0; end
    initial fork

        #20 Data = 8'ha5;
        #50 Data = 8'hff;

        #20 Ld = 0;
        #20 En = 0;
        #30 En = 1; // Drive to S_wait
        #70 Ld = 1; // Return to S_1 to S_full tp S_wait
        #80 Ld = 0;
        #100 Ld = 1; // Drive to S_idle
        #100 En = 0;
        #110 En = 0;
        #120 Ld = 0;
    join
endmodule
```

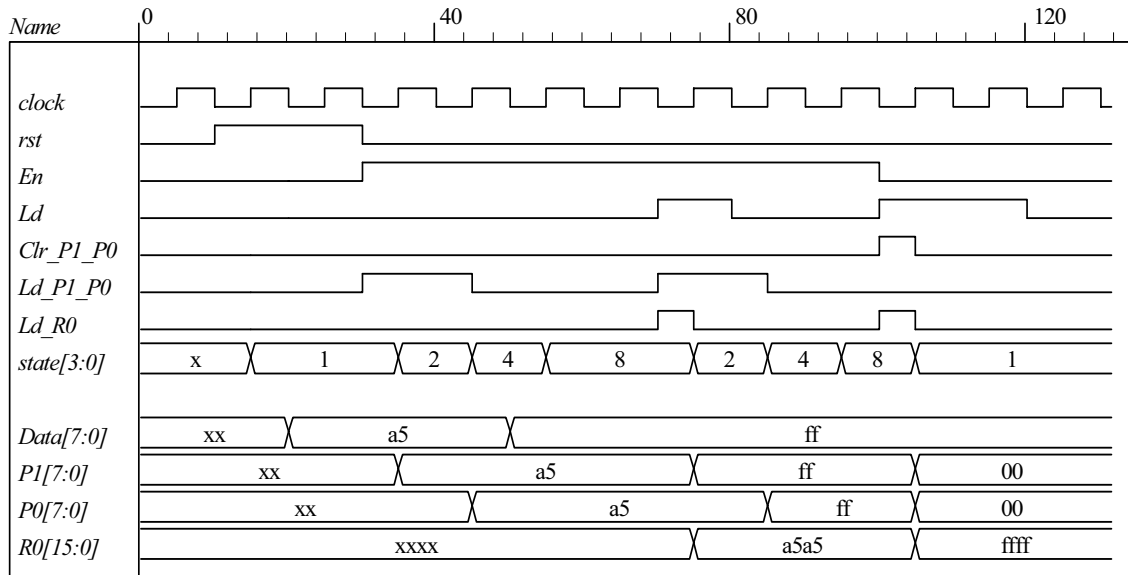

## CHAPTER 9

**9.1 (a)** Asynchronous circuits do not use clock pulses and change state in response to input changes. Synchronous circuits use clock pulses and a change of state occurs in response to the clock transition.

**(b)** The input signals change one at a time when the circuit is stable.

**(c)** The circuit is in a stable state when the excitation variables ( $Y$ ) are equal to the secondary variables ( $y$ ) (see F. 9.1). Unstable otherwise.

**(d)** The total state is the combination of binary values of the internal state and the inputs.

**9.2**

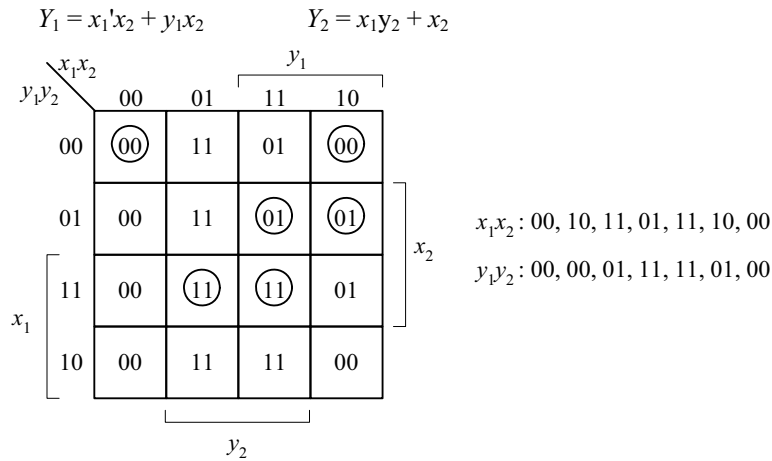

**9.3**

**(a)**

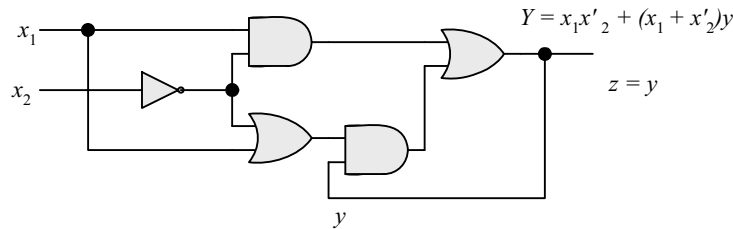

**(b)**

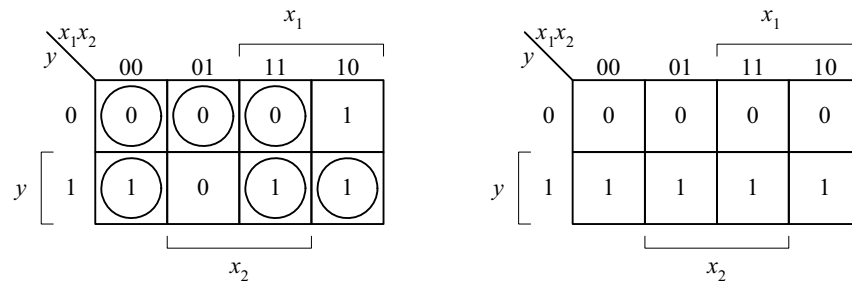

**(c)**